

CITY OF BEAUFORT
STATE OF SOUTH CAROLINA
REQUEST FOR PROPOSAL

RFP NO. 2018-105



CITY OF BEAUFORT
SOUTHSIDE PARK MULTI-USE TRAIL AND
PEDESTRIAN BRIDGE CONSTRUCTION
DUE: MONDAY, JANUARY 22, 2018 by 2:00 PM

CITY OF BEAUFORT, SC REQUEST FOR PROPOSAL RFP NO. 2018-105

SEALED PROPOSALS will be received in the Finance Department, 2nd Floor, City Hall, 1911 Boundary Street, Beaufort, South Carolina until **2:00 P.M. ET Monday, January 22, 2018** contractors are invited to submit proposals to the City of Beaufort for the following:

City of Beaufort

SOUTHSIDE PARK MUTIL-USE TRAIL AND PEDESTRIAN BRIDGE CONSTRUCTION

SUBMIT: One (1) unbound original and three (3) bound copies of all requested documentation must be received on or before **2:00 P.M. ET January 22, 2018**.

ADDRESS TO: City of Beaufort, City Hall, 2nd Floor Finance Department, Attention: Kathy Todd

MAILING ADDRESS: 1911 Boundary St., Beaufort, South Carolina 29902

OFFICE ADDRESS: 1911 Boundary St., Beaufort, South Carolina 29902

EMAIL ADDRESS: ktodd@cityofbeaufort.org

PHONE NUMBER: 843-525-7009

FAX NUMBER: 843-986-5606

MARK OUTSIDE ENVELOPE: "RFP NO. 2018-105 SOUTHSIDE PARK MULTI-USE TRAIL AND PEDESTRIAN BRIDGE CONSTRUCTION"

A MANDATORY PRE-PROPOSAL MEETING WILL BE HELD AT 10:00 A.M. ET ON JANUARY 5, 2018, IN THE PLANNING CONFERENCE ROOM OF CITY HALL, LOCATED AT 1911 BOUNDARY STREET, BEAUFORT, SC 29902. ALL POTENTIAL OFFERORS ARE REQUIRED TO ATTEND.

DEADLINE ENFORCED

PROPOSALS DELIVERED AFTER THE TIME AND DATE SET FOR RECEIPT OF PROPOSALS SHALL NOT BE ACCEPTED AND WILL BE RETURNED UNOPENED TO THE OFFEROR. IT IS THE OFFEROR'S RESPONSIBILITY TO ENSURE TIMELY DELIVERY OF THEIR PROPOSALS. WEATHER, FLIGHT DELAYS, CARRIER ERRORS AND OTHER ACTS OF OTHERWISE EXCUSABLE NEGLIGENCE ARE RISKS ALLOCATED TO OFFERORS AND WILL NOT BE EXEMPTED FROM DEADLINE REQUIREMENTS. E-MAIL, TELEPHONE, OR FACSIMILE PROPOSALS WILL NOT BE ACCEPTED.

Any offer submitted as a result of this RFP shall be binding on the offeror for **NINETY (90)** calendar days following the specified opening date. Any proposal for which the offeror specifies a shorter acceptance period may be rejected.

Proprietary and/or Confidential Information

Your proposal package is a public document under the South Carolina Freedom of Information Act (FOIA), except as to information that may be treated as confidential as an exception to disclosure under the FOIA. If you cannot agree to this standard, please do not submit your qualification.

All information that is to be treated as confidential and/or proprietary must be **CLEARLY** identified, and each page containing confidential and/or proprietary information, in whole or in part, must be stamped and/or denoted as **CONFIDENTIAL**, in bold, in a font of at least 12 point type, in the upper right hand corner of the page. *All information not so denoted and identified shall be subject to disclosure by the City.*

This Request for Proposal is being issued by the City of Beaufort. Direct all questions or request for clarification of this RFP by email, mail, or fax to contact information listed above.

Offerors are specifically directed not to contact any other City personnel for meetings, conferences, or technical discussions related to this request unless otherwise stated in this RFP. Failure to adhere to this policy may be grounds for rejection of your proposal.

Offerors ARE CAUTIONED that any statement made by City staff persons that materially change any portion of this RFP shall not be relied upon unless they are subsequently ratified by a formal written amendment to this RFP. Any revisions to this RFP will be issued and distributed as an addendum. All addenda, additional communications, responses to questions, etc. pertaining to the Request for PROPOSAL may be accessed on the City of Beaufort website under Quick Links – “Bid Opportunities” at www.cityofbeaufort.org.

All Offerors should consult this website for updates before submitting bids.

THE DEADLINE FOR QUESTIONS IS: 4:00 P.M., JANUARY 12, 2018. ANSWERS TO SUBMITTED QUESTIONS WILL BE POSTED ON THE CITY WEBSITE BY 4:00 PM ON JANUARY 17, 2018.

If the Offeror discovers any ambiguity, conflict, discrepancy, omission or other error in the RFP, Offeror shall immediately notify the City of such error in writing and request modification or clarification of the document. The Offeror is responsible for clarifying any ambiguity, conflict, discrepancy; omission or other error in the RFP or it shall be deemed waived.

The City of Beaufort reserves the right to reject any or all proposals, or any parts thereof, waive informalities, negotiate terms and conditions, and to select an Offeror that best meets the needs of the City of Beaufort and its employees.

Compliance with the South Carolina Illegal Immigration Reform Act

Any Contractor entering into a service contract with the City of Beaufort must certify to the City of Beaufort that the Contractor intends to verify any new employees’ status, and require any sub-consultants performing services under the service contract to verify their new employees’ status, per the terms of the South Carolina Illegal Immigration Reform Act, and as set out in Title 41, Chapter 8 of the Code of Laws of South Carolina, 1976.

POLICY CONCERNING MINORITY AND WOMAN OWNED BUSINESS ENTERPRISES

Intent

Businesses owned and operated by women and minority persons, in general, have been historically restricted from full participation in the nation's free enterprise system to a degree disproportionate to other businesses.

The City believes it is in the community's best interest to assist minority and woman owned businesses to develop fully, in furtherance of City's policies and programs which are designed to promote balanced economic and community growth.

The City, therefore, wishes to ensure that minority and woman owned businesses (M/WBEs) are afforded the opportunity to fully participate in the City's overall procurement process and will not be discriminated against on the grounds of race, color, sex, or national origin in consideration for an award.

Goal for Participation

The City adopts the State of South Carolina's goal for participation of M/WBEs: ten percent (10%) of annual controllable procurement expenditures which are defined as agreements between the City and a Vendor to provide or procure labor, materials, equipment, supplies and services to, for or on behalf of the City. However, a specific expectation has not been set for this RFP.

Required Forms

Contractors submitting proposals are required to include completed forms that are found at the end of the General Terms & Conditions. The City's General Terms & Conditions, a required component of all competitive procurement proposals, may be accessed on the City's website under Quick Links – Bid Opportunities – www.cityofbeaufort.org. All proposers are to certify that they have read the General Terms & Conditions and will adhere to them as a component of the contract documents.

Contractors should also be aware that, should a contract be awarded, the City will require reports of the utilization of any minority business enterprises to be filed along with requests for payment. The City reserves the right to audit accuracy of the utilization reports that are filed.

The City of Beaufort reserves the right to reject any or all bids; to waive any informality or irregularity not affected by law; to evaluate, in its absolute discretion, the bids submitted; to award the contract according to the bid which best serves the interests of the City; or to not award the contract if the City determines that it is not in its best interest to do so.

Proposals that are not signed will not be accepted as complete and shall not be considered. Proposals must be signed in ink (not typed) in the appropriate space(s) by an authorized officer or employee of the offeror.

The words "Bidder", "Offeror", "Proposer", "Vendor", "Operator", "Contractor", and "Company" are used interchangeably throughout this RFP, and are used in place of the person, vendor, or corporation submitting a bid.

REQUEST FOR PROPOSAL
CITY OF BEAUFORT
SOUTHSIDE PARK MULTI-USE TRAIL AND PEDESTRIAN BRIDGE CONSTRUCTION (RFP 2018-105)

I. INTRODUCTION

This project is meant to develop a 1.2-mile multi-use trail in one of the City of Beaufort's largest and most undeveloped parks. The completed trail will meander throughout the 35-acre park in a curvilinear path that loops the trail user through a variety of habitats including open fields, forested areas, and bridges over an existing wetland. Located in one of the most heavily populated areas of the City, this project will provide a much-needed recreational resource for the surrounding neighborhood and provide connectivity to the Spanish Moss Trail system.

SCOPE OF WORK

The Southside Park Trail project consists of grading, paving, drainage, driving piles, wood construction, and concrete work for approximately 1.20 miles of trail improvements within the boundaries of Southside Park. The typical trail cross section consists of a 10' wide gravel multi-use path with lawn on each side. The project also consists of the installation of a 10' wide wooden pedestrian bridge to cross a creek that runs thru the site. The construction of fencing with bollards at (4) entry points into the park and (3) cross walks with bollards to keep vehicles from driving onto the trail. There are also (2) additional trail entry points with bollards and (4) trail locations where drainage pipe will cross under the trail to allow for water flow.

This project is funded with Grant money from the States Recreational Trails Program and matching funds from the City of Beaufort. The construction of this project shall be in accordance with the City of Beaufort Development Code and all Federal and State Building Standards that apply to the construction of the Pedestrian Bridge, ADA Accessible Trail, Entry Points, Bollards, and Crosswalks.

II. SITE INSPECTION

There will be weekly site inspections by the City's Landscape Architect that will occur on Friday of every week. Meeting days may be adjusted due to weather or holidays.

III. CONSTRUCTION DOCUMENTS

Construction drawings are included under Attachment A that contains sheets L1 thru L8. The set contains an overall masterplan, detailed grading plan sheets, trail and bridge construction details with notes.

IV. ADDITIONAL DOCUMENTS AND INFORMATION

There is a sewer force main that is to be installed by Beaufort Jasper Water and Sewer Authority through the site that will require the awarded contractor to coordinate with the utility company. In addition, the awarded contractor will be required to coordinate with the City Public Works Department with work that Department will be conducting related to existing curb to accommodate crosswalks, painting of the crosswalks, concrete work, tree removal, and culvert installation, etc.

There is also a pile of asphalt millings on site that will be used as the base layer in constructing the trail. Bidders will need to review this material and include its use in their bid.

Additional documents are available online under "Appendix A." Proposers are required to review and be familiar with these documents as they are a part of the RFQ and will become part of the awarded contract. These documents also include the Price Summary Form (Attachment A). These additional documents may be accessed on the City of Beaufort website under Quick Links – "Bid Opportunities" at www.cityofbeaufort.org.

V. SUBMISSION REQUIREMENTS

- I. **Required content of proposal:** The detailed requirements set forth in the Proposal Format are recommended. Failure by any Proposer to respond to a specific requirement may result in disqualification. Proposers are reminded that proposals will be considered exactly as submitted. Points of clarification will be solicited from proposers at the discretion of the City. Those proposals determined not to be in compliance with provisions of this RFP and the applicable law and/or regulations will not be processed. In addition to the information required as described below, a Respondent may submit supplemental information that it feels may be useful in evaluating its proposal. This information may include documents such as a firm profile or brochure.

All costs incurred by the Proposer associated with RFP preparations and subsequent interviews and/or negotiations, which may or may not lead to execution of a contract, shall be the responsibility entirely and exclusively by the proposer.

- II. **Proposal format:** The proposal format requirements were developed to aid Proposers in their proposal development. They also provide a structured format so reviewers can systematically evaluate several proposals. These directions apply to all proposals submitted.

The purpose of the Proposal is to demonstrate the technical capabilities, professional qualifications, past project experiences, and knowledge within this industry. Proposer's proposal must address all the points outlined herein as required, in the following order.

- a. **Transmittal Letter:** A transmittal letter must be submitted with a Proposer's proposal which shall include:
 - i. Name of the firm responding, including mailing address, e-mail address, telephone number, and names of contact person.
 - ii. The name of the person or persons authorized to make representations on behalf of the Proposer, binding the firm to a contract.
 - iii. Prepare an executive summary stating the respondent's understanding of the project and opinion why the respondent's firm should be chosen. Include any general information the proposer wishes the City to consider about the proposal.
 - iv. An affirmative statement that the proposer has read and agrees to the General Terms and Conditions and will adhere to them as a component of the contract documents.

b. Proposer's Work History and References:

- i. Provide client references (name, address, e-mail and phone number) for a minimum of three projects of a similar size and nature. References from South Carolina and the southeast United States are preferred.
- ii. Identify any additional or unique resources, options, capabilities or assets which the Proposer would bring to this project.

c. Required Forms:

- i. Proposals must include the required forms.
 - 1. Certificates of Insurance showing present coverage as described in the "Insurance" section of the General Terms and Conditions.
 - 2. Ethics in Public Contracting Certification
 - 3. Non-Collusion Affidavit
 - 4. Small / Woman-Owned / Minority Business Enterprise Form
 - 5. Non-Resident Taxpayer Affidavit (S.S. Department of Revenue I-312)
 - 6. RFP Signature page (must be signed in ink)
- ii. Unit Price Schedule that breaks down all costs.

d. Other Information to Provide:

- i. List any lawsuits or arbitration proceedings that have been initiated by or against your company in the past five years. Briefly describe the nature of the action and the outcome.
- ii. Proposer shall be responsible for providing a letter from the surety company that would issue Performance and Payment bonds for the Contractor included on your team, providing information on the Contractor's bonding capacity. Performance and Payment bonds are required.

VI. PROPOSAL EVALUATION

The City will evaluate proposals based on the factors outlined within this RFP, which shall be applied to all eligible, responsive proposals in selecting the successful firm. The City reserves the right to disqualify any proposal for, but not limited to; person or persons it deems as non-responsive and/or non-responsible. The City reserves the right to make such investigations of the qualifications of the Proposer as it deems appropriate.

Lowest responsible bidder. Contracts shall be awarded to the lowest responsible bidder. In determining "lowest responsible bidder", in addition to price, the City shall consider:

- (a) The ability, capacity and skill of the bidder to perform the contract or provide the service required;
- (b) Whether the bidder can perform the contract or provide the service promptly, or within the time specified, without delay or interference;

- (c) The character, integrity, reputation, judgment, experience and efficiency of the bidder;
- (d) The quality of performance of previous contracts or services;
- (e) The previous and existing compliance by the bidder with laws and ordinances relating to the contract or services;
- (f) The sufficiency of the financial resources and ability of the bidder to perform the contract or provide the service;
- (g) The quality, availability and adaptability of the supplies or contractual services to the particular use required;
- (h) The ability of the bidder to provide future maintenance and service for the use of the subject: of the contract;
- (i) The number and scope of conditions attached to the bid.

It is the City's intent to contract with one proposer to provide the services as detailed herein. Award of any proposal may be made without discussion with Proposers after responses are received. The Proposers submitting sealed proposals will be evaluated by an evaluation committee. The committee will evaluate each component separately. After careful evaluation, the committee will rank the Proposers and make a recommendation to the City Manager of the lowest responsible bidder. The City reserves the right to accept or reject any and all bids that is in the best interest of the City.

The City may choose to interview one or more contractor(s) responding to this RFP. The City reserves the right to request and obtain, from one or more contractor(s), supplementary information as may be necessary for the City to analyze the proposal pursuant to the evaluation criteria. The City reserves the right to accept or reject any and all proposals that is in the best interest of the City.

CITY OF BEAUFORT
SOUTH CAROLINA
RFP SIGNATURE PAGE
RFP NO. 2018-105

PROPOSER'S NAME: _____

The undersigned, having become familiar with the existing conditions and the Proposal Scope of Services hereby proposed, agrees to complete the work as described in accordance with the Request for Proposal and Contract Documents.

Proposer warrants that no gratuities, in the form of gifts, entertainment, or otherwise, were offered or given by the **Proposer**, to any officer or employee of the City with a view toward securing the contract or securing favorable treatment with respect to any determination concerning the performance of the contract.

This offer is genuine and not made in interest of or on behalf of any undisclosed person, vendor or corporation and is not submitted in conformity with any agreement or rules of any group, association, organization or corporation; **Proposer** has not directly induced or solicited any other **Proposer** to submit false or sham bid; **Proposer** has not solicited or sought by collusion to obtain for itself any advantage over any other **Proposer** or other **Owner**.

The words "Bidder", "Offeror", "Proposer", "Vendor", and "Company" are used interchangeably throughout this solicitation, and are used in place of the person, vendor, or corporation submitting a solicitation.

Proposer has examined copies of all documents and of the following addenda (if applicable):

Addendum No.	Date
_____	_____
_____	_____
_____	_____

Address: Post Office Box: _____ Zip: _____
Street: _____ Zip: _____
City: _____ State: _____
Telephone: _____ Fax: _____
Email: _____

*Signature: _____ Title: _____

Proposal will not be accepted unless signed in ink (not typed) in the appropriate space by an authorized officer or employee of the bidder.

Printed Name: _____ Date: _____



ATTACHMENT A



CITY OF BEAUFORT

1911 Boundary Street
Beaufort, SC 29902
www.cityofbeaufort.org

Southside Park

Overall
Masterplan

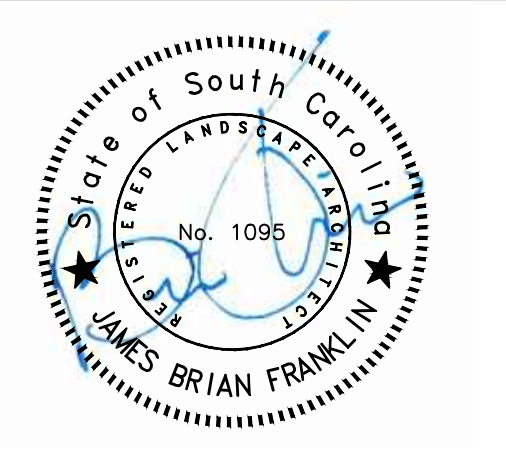

PROJECT NO.: 2170000	
DATE DRAWN: 11.30.17	
DRAWN BY: BF	
CHECKED BY:	
REVISED:	
DATE	REVISIONS

This drawing is the exclusive property of the City of Beaufort. It may not be copied, reproduced, modified, published or used in any manner without written permission.

SHEET NUMBER:
L1
OF 8

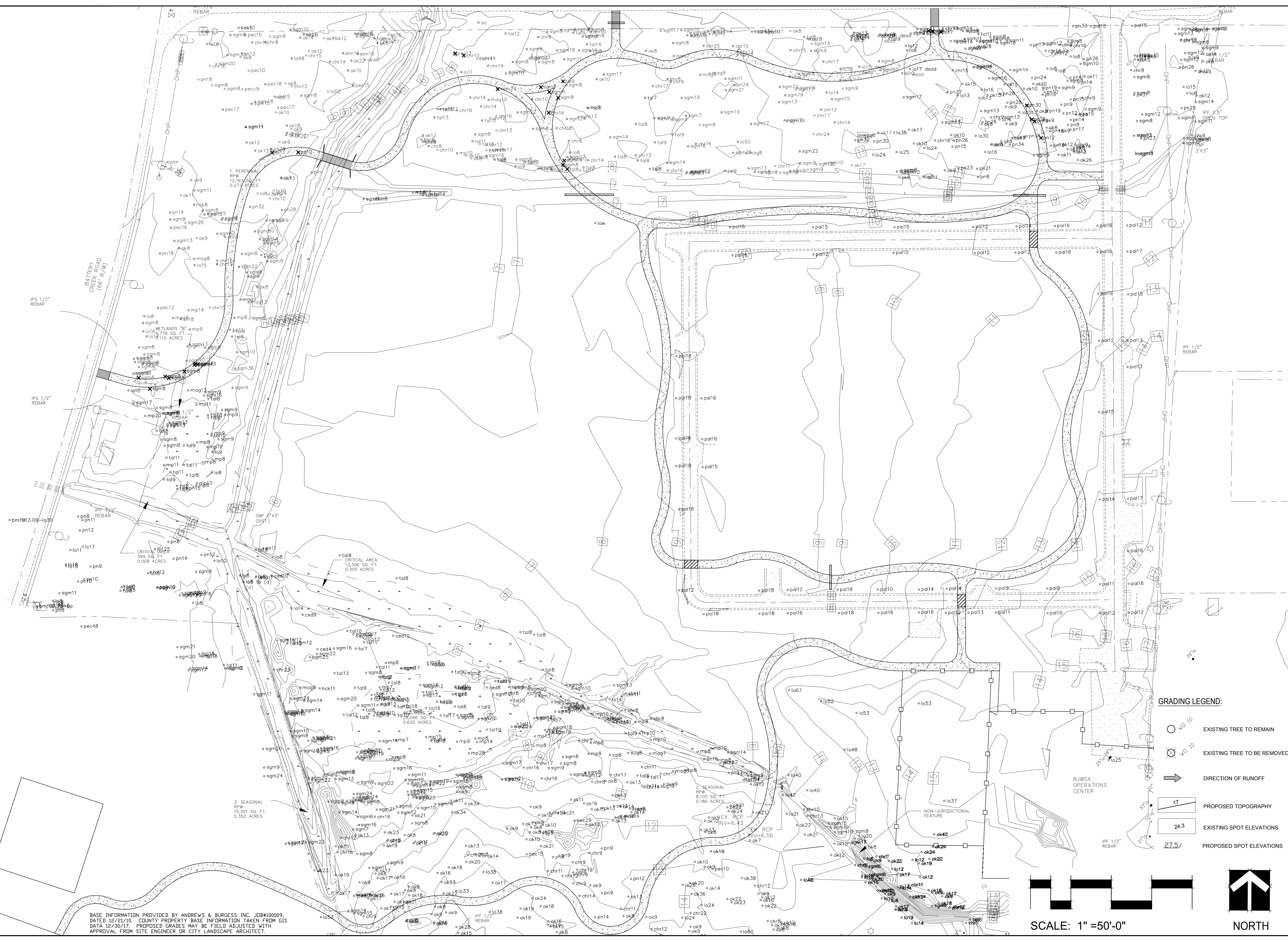

BASE INFORMATION PROVIDED BY ANDREWS & BURGESS INC. JOB#100009,
DATED 12/21/10. COUNTY PROPERTY BASE INFORMATION TAKEN FROM GIS
DATA 12/30/17. PROPOSED GRADES MAY BE FIELD ADJUSTED WITH
APPROVAL FROM SITE ENGINEER OR CITY LANDSCAPE ARCHITECT.

SCALE: 1" = 50'-0"

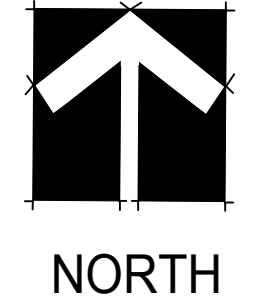



CITY OF BEAUFORT

1911 Boundary Street
Beaufort, SC 29902
www.cityofbeaufort.org

Southside Park

Grading
Plan

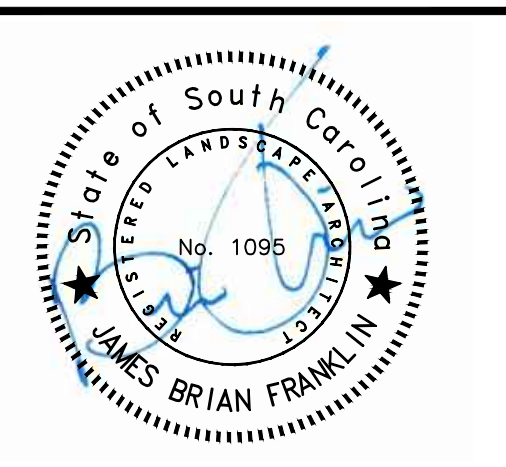

PROJECT NO.: 2170000
DATE DRAWN: 11.30.17
DRAWN BY: BF
CHECKED BY:
REVISED BY:
DATE REVISIONS

This drawing is the exclusive property of the City of Beaufort. It may not be copied, reproduced, modified, published or used in any manner without written permission.

SHEET NUMBER:

L2
OF 8

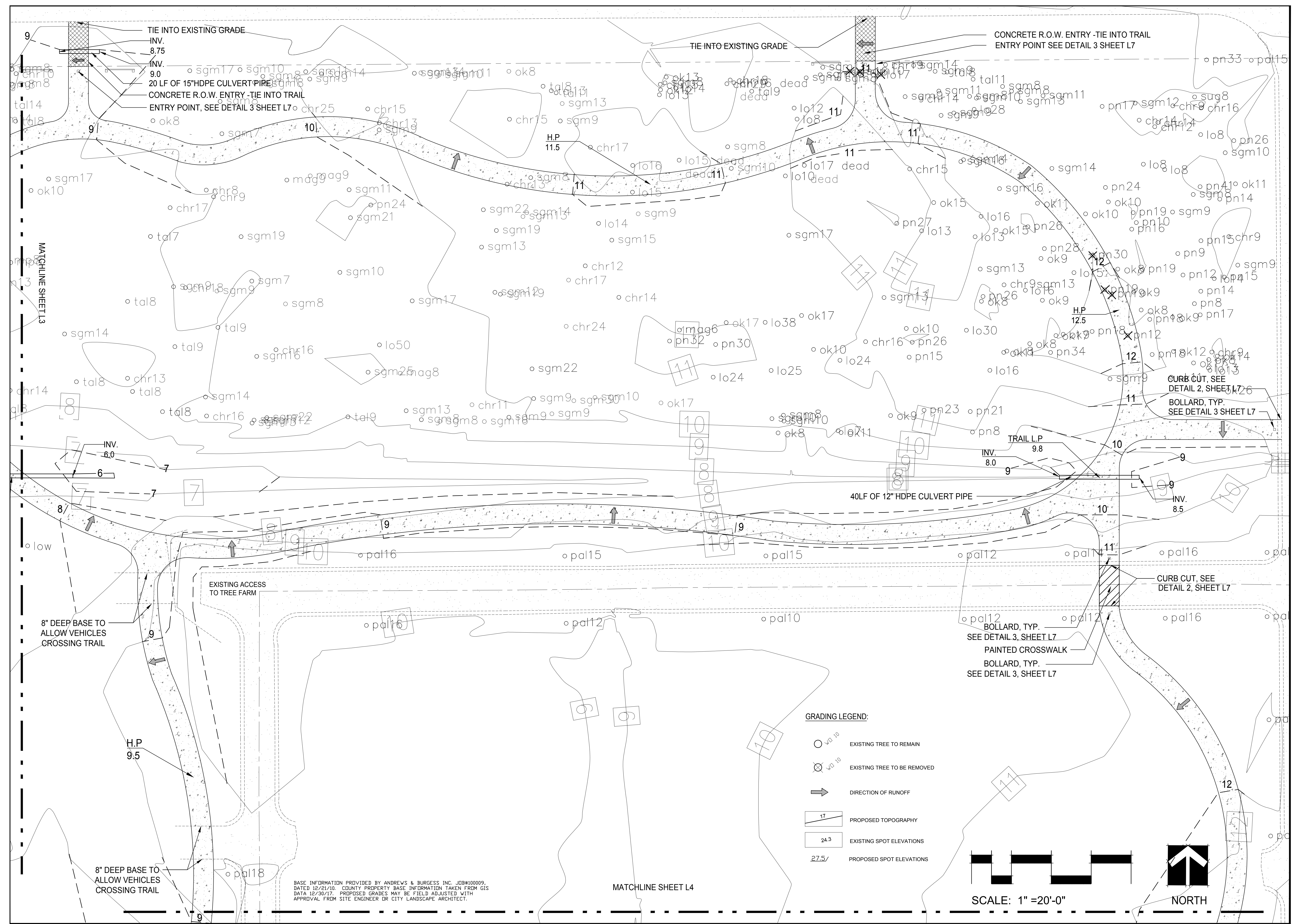

- GRADING LEGEND:**
- EXISTING TREE TO REMAIN
 - EXISTING TREE TO BE REMOVED
 - DIRECTION OF RUNOFF
 - PROPOSED TOPOGRAPHY
 - EXISTING SPOT ELEVATIONS
 - PROPOSED SPOT ELEVATIONS

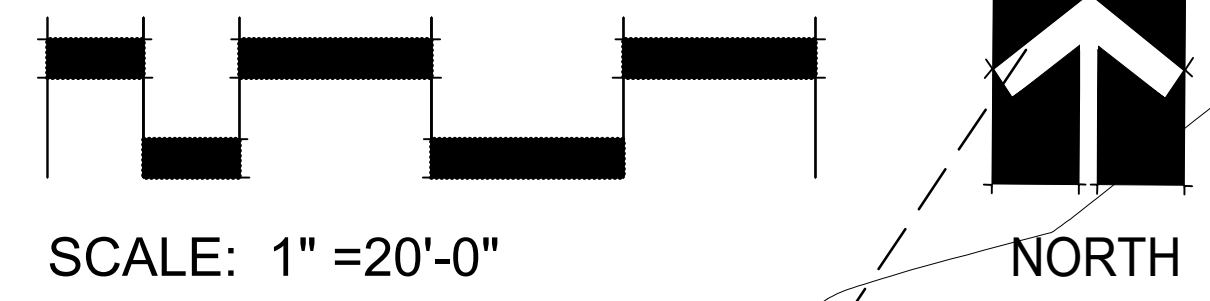

BASE INFORMATION PROVIDED BY ANDREWS & BURGESS INC. JDB#100009, DATED 12/21/10. COUNTY PROPERTY BASE INFORMATION TAKEN FROM GIS DATA 12/30/17. PROPOSED GRADES MAY BE FIELD ADJUSTED WITH APPROVAL FROM SITE ENGINEER OR CITY LANDSCAPE ARCHITECT.

MATCHLINE SHEET L4

MATCHLINE SHEET L3

INV. 6.0

8" DEEP BASE TO ALLOW VEHICLES CROSSING TRAIL

H.P. 9.5

8" DEEP BASE TO ALLOW VEHICLES CROSSING TRAIL

10
9
8
7
6
5
4
3
2
1

11
10
9
8
7
6
5
4
3
2
1

CURB CUT, SEE
DETAIL 2, SHEET L7
BOLLARD, TYP.
SEE DETAIL 3 SHEET L7

BOLLARD, TYP.
SEE DETAIL 3, SHEET L7
PAINTED CROSSWALK
BOLLARD, TYP.
SEE DETAIL 3, SHEET L7

CURB CUT, SEE
DETAIL 2, SHEET L7

TRAIL L.P.
INV. 9.8

INV. 8.0

INV. 8.5

INV. 9.0

INV. 8.5

H.P. 11.5

H.P. 12.5

TIE INTO EXISTING GRADE
INV. 8.75
INV. 9.0
20 LF OF 15" HDPE CULVERT PIPE
CONCRETE R.O.W. ENTRY - TIE INTO TRAIL
ENTRY POINT, SEE DETAIL 3 SHEET L7

TIE INTO EXISTING GRADE
CONCRETE R.O.W. ENTRY - TIE INTO TRAIL
ENTRY POINT SEE DETAIL 3 SHEET L7

40LF OF 12" HDPE CULVERT PIPE

EXISTING ACCESS
TO TREE FARM

CURB CUT, SEE
DETAIL 2, SHEET L7

INV. 6.0

8" DEEP BASE TO ALLOW VEHICLES CROSSING TRAIL

H.P. 9.5

8" DEEP BASE TO ALLOW VEHICLES CROSSING TRAIL

MATCHLINE SHEET L4

BASE INFORMATION PROVIDED BY ANDREWS & BURGESS INC. JDB#100009, DATED 12/21/10. COUNTY PROPERTY BASE INFORMATION TAKEN FROM GIS DATA 12/30/17. PROPOSED GRADES MAY BE FIELD ADJUSTED WITH APPROVAL FROM SITE ENGINEER OR CITY LANDSCAPE ARCHITECT.



CITY OF BEAUFORT

1911 Boundary Street
Beaufort, SC 29902
www.cityofbeaufort.org

Southside Park

Grading
Plan

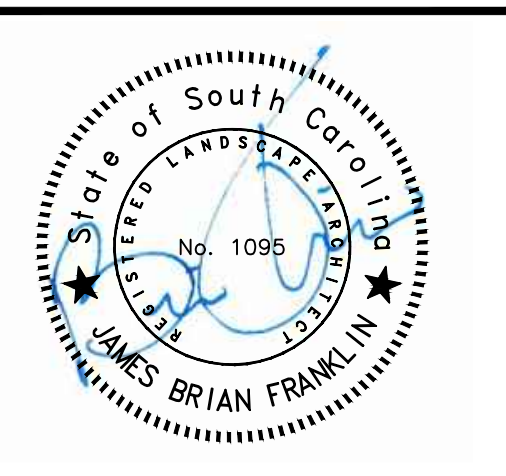

PROJECT NO.:	2170000
DATE DRAWN:	11.30.17
DRAWN BY:	BF
CHECKED BY:	
REVISED:	
DATE	REVISIONS

This drawing is the exclusive property of the City of Beaufort. It may not be copied, reproduced, modified, published or used in any manner without written permission.

SHEET NUMBER:

L3
OF 8

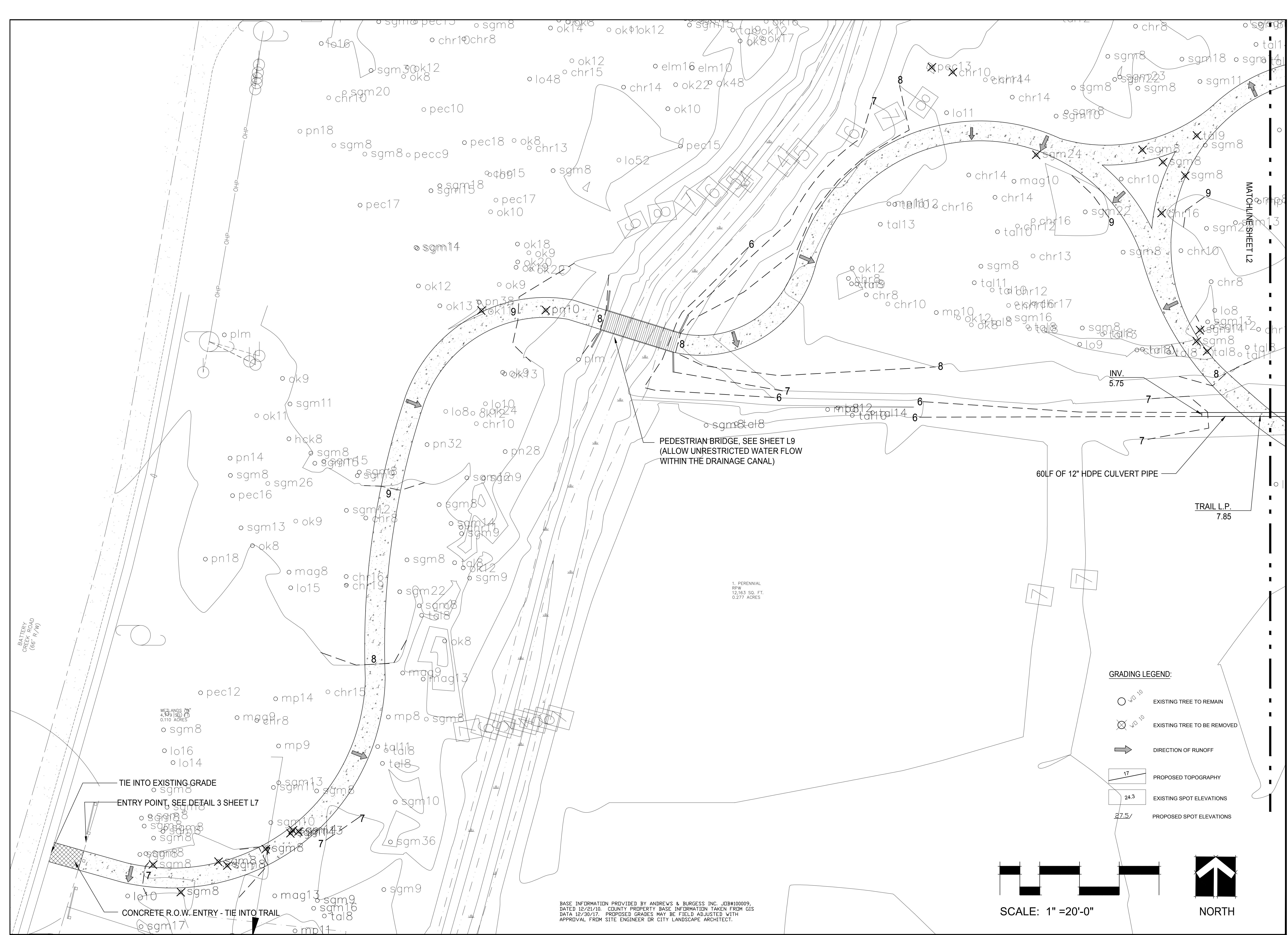

BASE INFORMATION PROVIDED BY ANDREWS & BURGESS INC. JOB#100009. DATED 12/21/10. COUNTY PROPERTY BASE INFORMATION TAKEN FROM GIS DATA 12/30/17. PROPOSED GRADES MAY BE FIELD ADJUSTED WITH APPROVAL FROM SITE ENGINEER OR CITY LANDSCAPE ARCHITECT.

SCALE: 1" = 20'-0"

NORTH



CITY OF BEAUFORT

1911 Boundary Street
Beaufort, SC 29902
www.cityofbeaufort.org

Southside Park

Grading
Plan

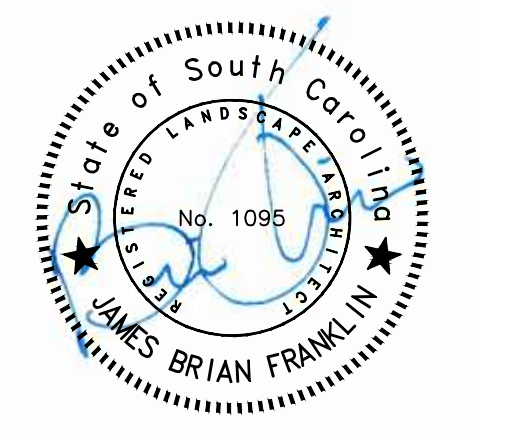

PROJECT NO.: 2170000
DATE DRAWN: 11.30.17
DRAWN BY: BF
CHECKED BY:
REVISED:
DATE REVISIONS

This drawing is the exclusive property of the City of Beaufort. It may not be copied, reproduced, modified, published or used in any manner without written permission.

SHEET NUMBER:

L4
OF 8

MATCHLINE SHEET L2

GRADING LEGEND:

- EXISTING TREE TO REMAIN
- EXISTING TREE TO BE REMOVED
- DIRECTION OF RUNOFF
- PROPOSED TOPOGRAPHY
- EXISTING SPOT ELEVATIONS
- PROPOSED SPOT ELEVATIONS

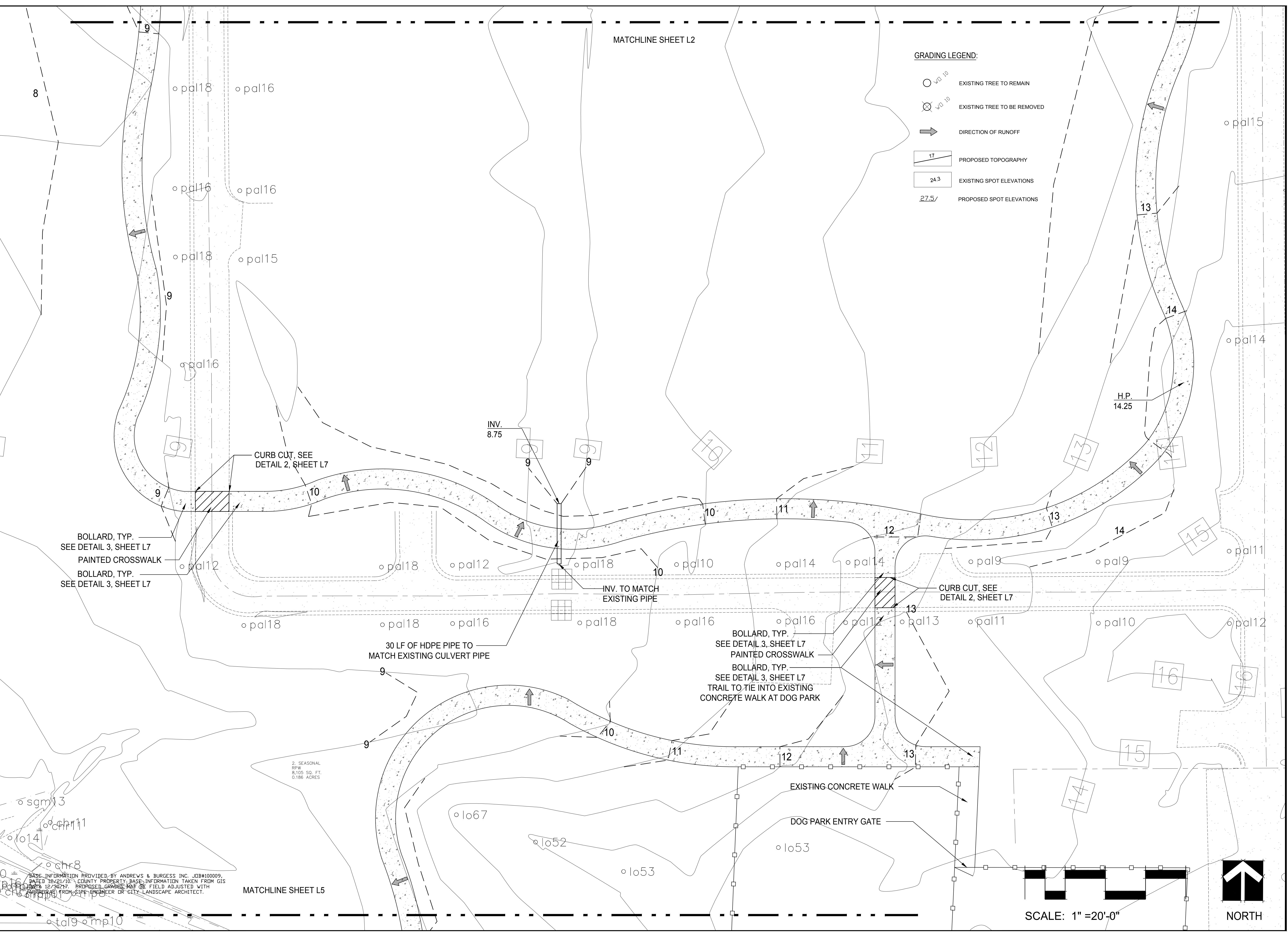

BASE INFORMATION PROVIDED BY ANDREWS & BURGESS INC. JOB#100099. DATED 12/21/10. COUNTY PROPERTY BASE INFORMATION TAKEN FROM GIS DATA 12/30/17. PROPOSED GRADES MAY BE FIELD ADJUSTED WITH APPROVAL FROM SITE ENGINEER OR CITY LANDSCAPE ARCHITECT.

MATCHLINE SHEET L5

SCALE: 1" = 20'-0"

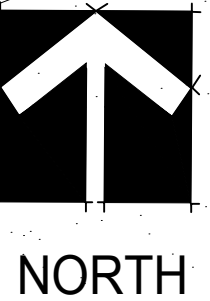



CITY OF BEAUFORT

1911 Boundary Street
Beaufort, SC 29902
www.cityofbeaufort.org

Southside Park

Grading Plan

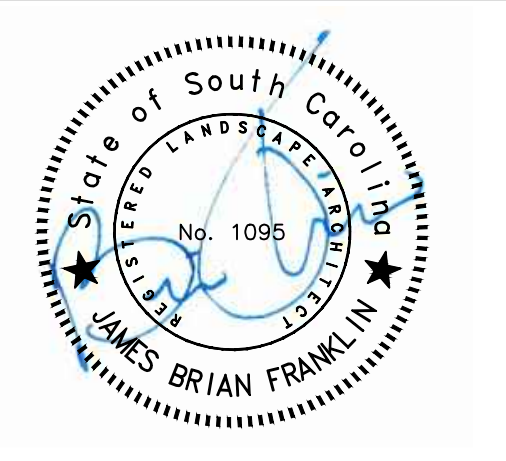

PROJECT NO.: 2170000
DATE DRAWN: 11.30.17
DRAWN BY: BF
CHECKED BY:
REVISED:

DATE	REVISIONS

This drawing is the exclusive property of the City of Beaufort. It may not be copied, reproduced, modified, published or used in any manner without written permission.

SHEET NUMBER:

L5
OF 8

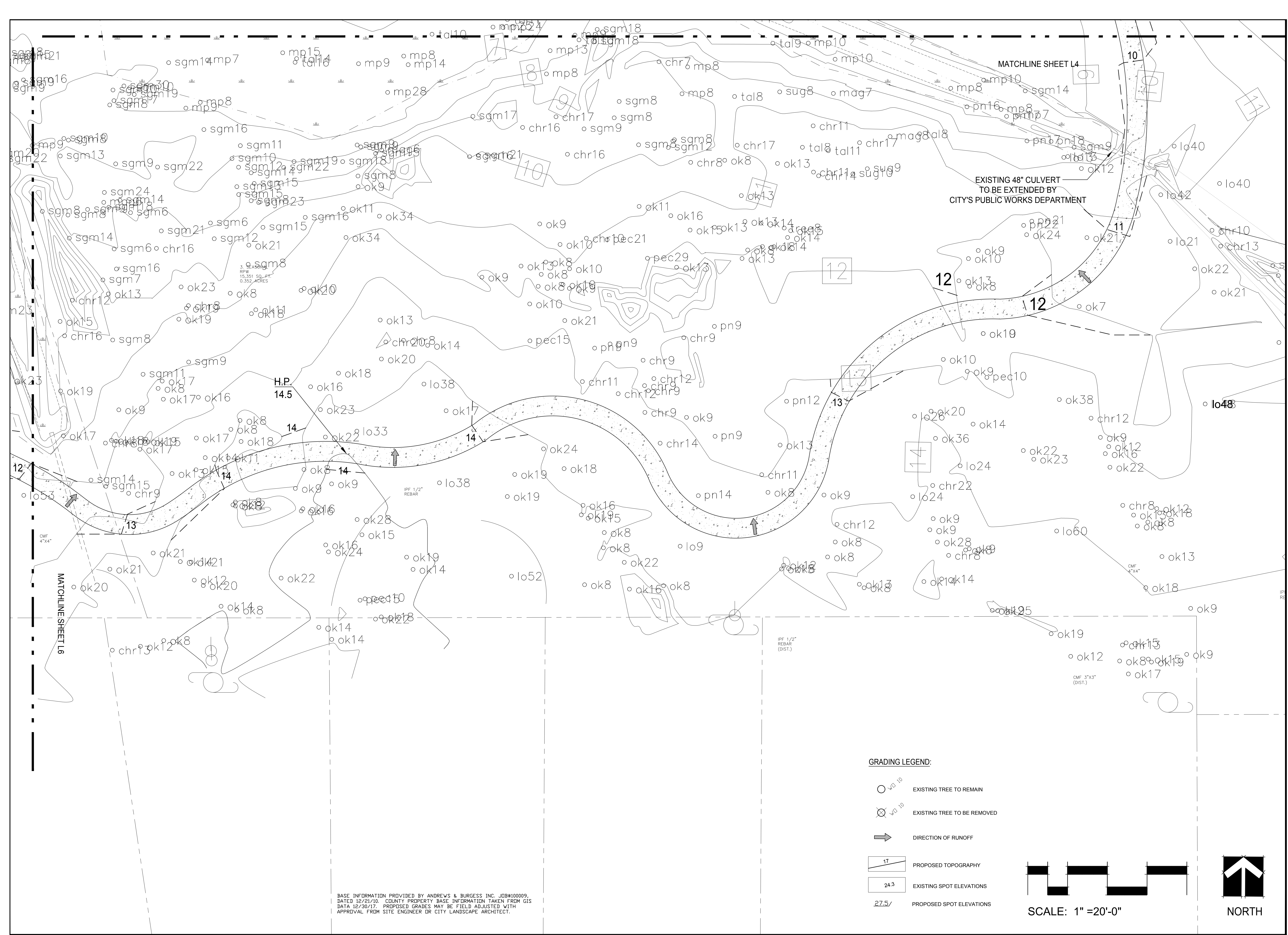

GRADING LEGEND:

- EXISTING TREE TO REMAIN
- EXISTING TREE TO BE REMOVED
- DIRECTION OF RUNOFF
- PROPOSED TOPOGRAPHY
- EXISTING SPOT ELEVATIONS
- PROPOSED SPOT ELEVATIONS

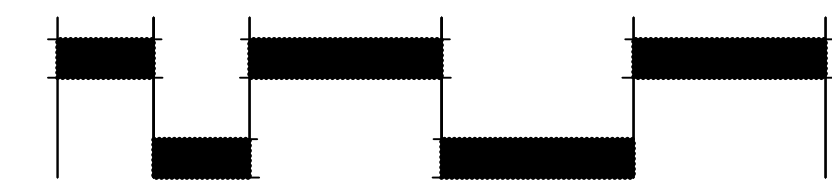

SCALE: 1" = 20'-0"

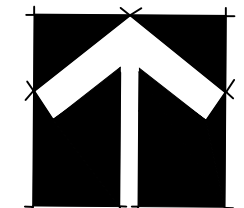

NORTH

BASE INFORMATION PROVIDED BY ANDREWS & BURGESS INC. JOB#100009, DATED 12/21/10. COUNTY PROPERTY BASE INFORMATION TAKEN FROM GIS DATA 12/30/17. PROPOSED GRADES MAY BE FIELD ADJUSTED WITH APPROVAL FROM SITE ENGINEER OR CITY LANDSCAPE ARCHITECT.



CITY OF BEAUFORT

1911 Boundary Street
Beaufort, SC 29902
www.cityofbeaufort.org

Southside Park

Grading
Plan

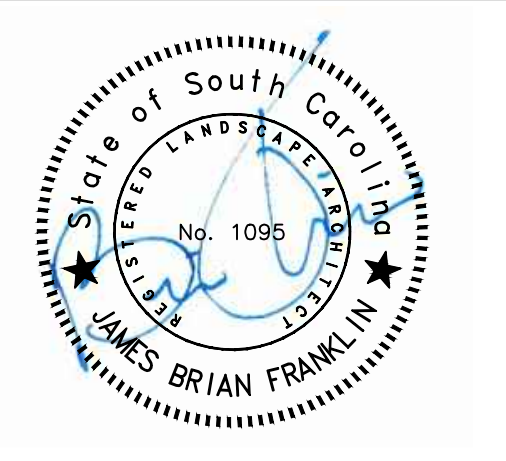

PROJECT NO.: 2170000
DATE DRAWN: 11.30.17
DRAWN BY: BF
CHECKED BY:
REVISED:

DATE	REVISIONS

This drawing is the exclusive property of the City of Beaufort. It may not be copied, reproduced, modified, published or used in any manner without written permission.

SHEET NUMBER:

L6
OF 8

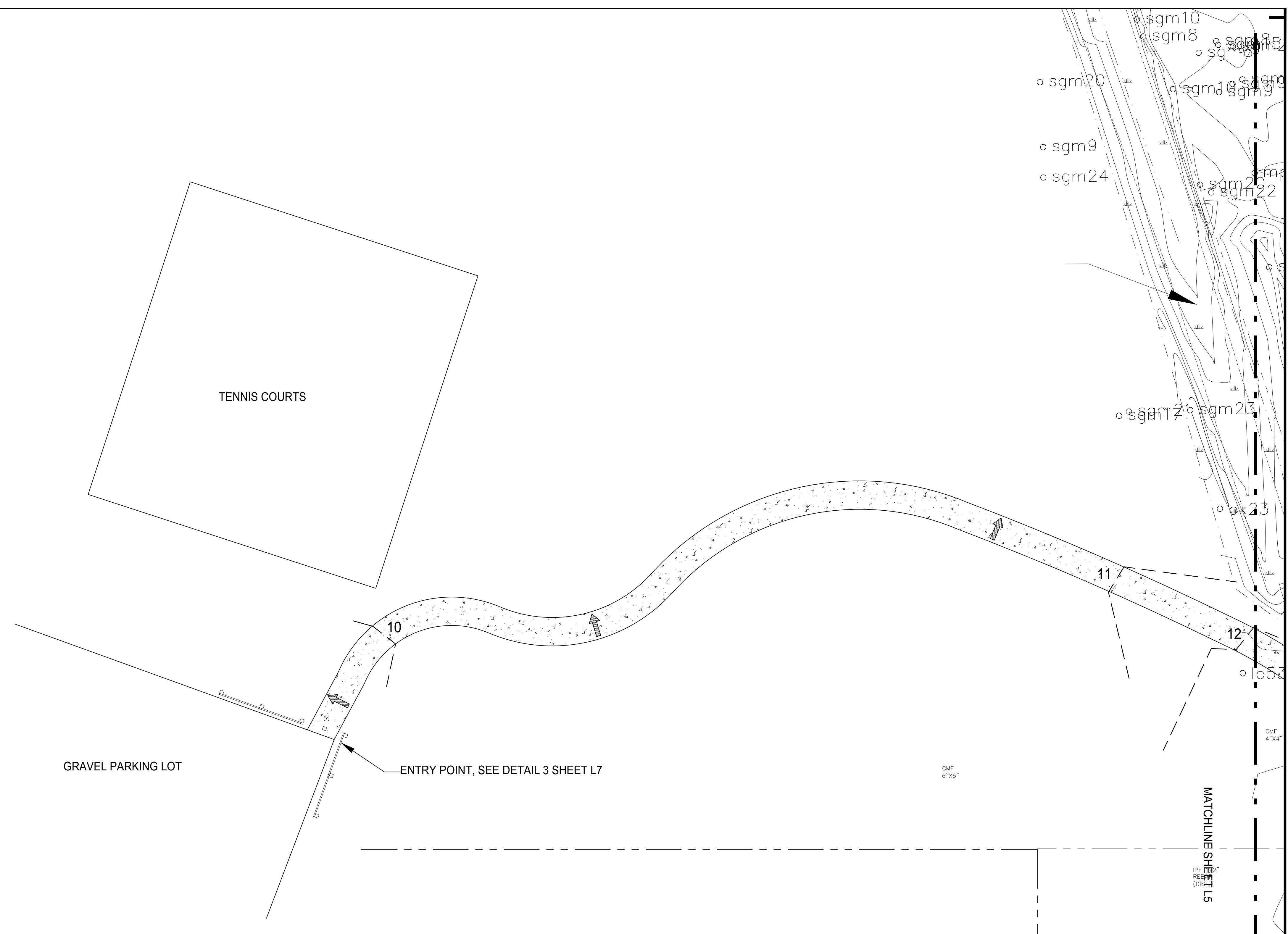

GRADING LEGEND:

- EXISTING TREE TO REMAIN
- EXISTING TREE TO BE REMOVED
- DIRECTION OF RUNOFF
- PROPOSED TOPOGRAPHY
- EXISTING SPOT ELEVATIONS
- PROPOSED SPOT ELEVATIONS

BASE INFORMATION PROVIDED BY ANDREWS & BURGESS INC. JOB#100009,
DATED 12/21/10. COUNTY PROPERTY BASE INFORMATION TAKEN FROM GIS
DATA 12/26/17. PROPOSED GRADES MAY BE FIELD ADJUSTED WITH
APPROVAL FROM SITE ENGINEER OR CITY LANDSCAPE ARCHITECT.

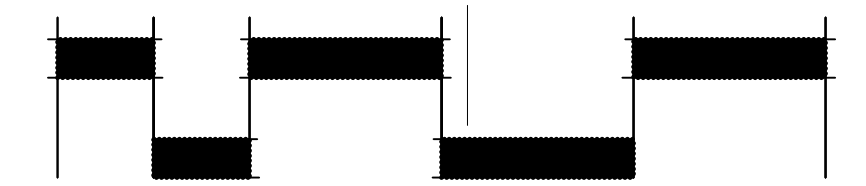

SCALE: 1" = 20'-0"

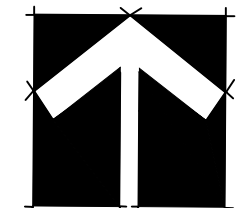

NORTH

GENERAL TRAIL NOTES:

1. GRADE STAKES ALONG THE CL OF THE TRAIL WILL BE PROVIDED EVERY 25 LF. OR AS SPECIFIED ON THE GRADING PLAN.
2. IT WILL BE THE CONTRACTORS RESPONSIBILITY TO DETERMINE GRADE OFFSETS.
3. ANY DEVIATION FROM APPROVED PLANS WILL REQUIRE APPROVAL FROM CITY OF BEAUFORT LANDSCAPE ARCHITECT.

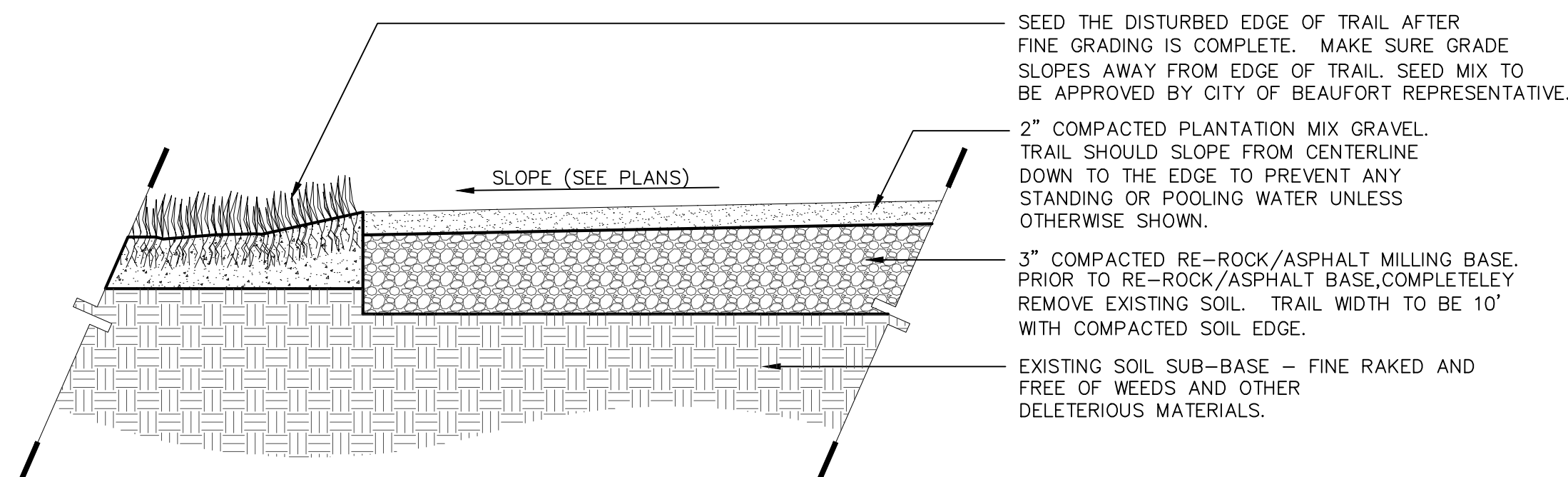

1
L7
MULTI-USE TRAIL
SCALE: NTS

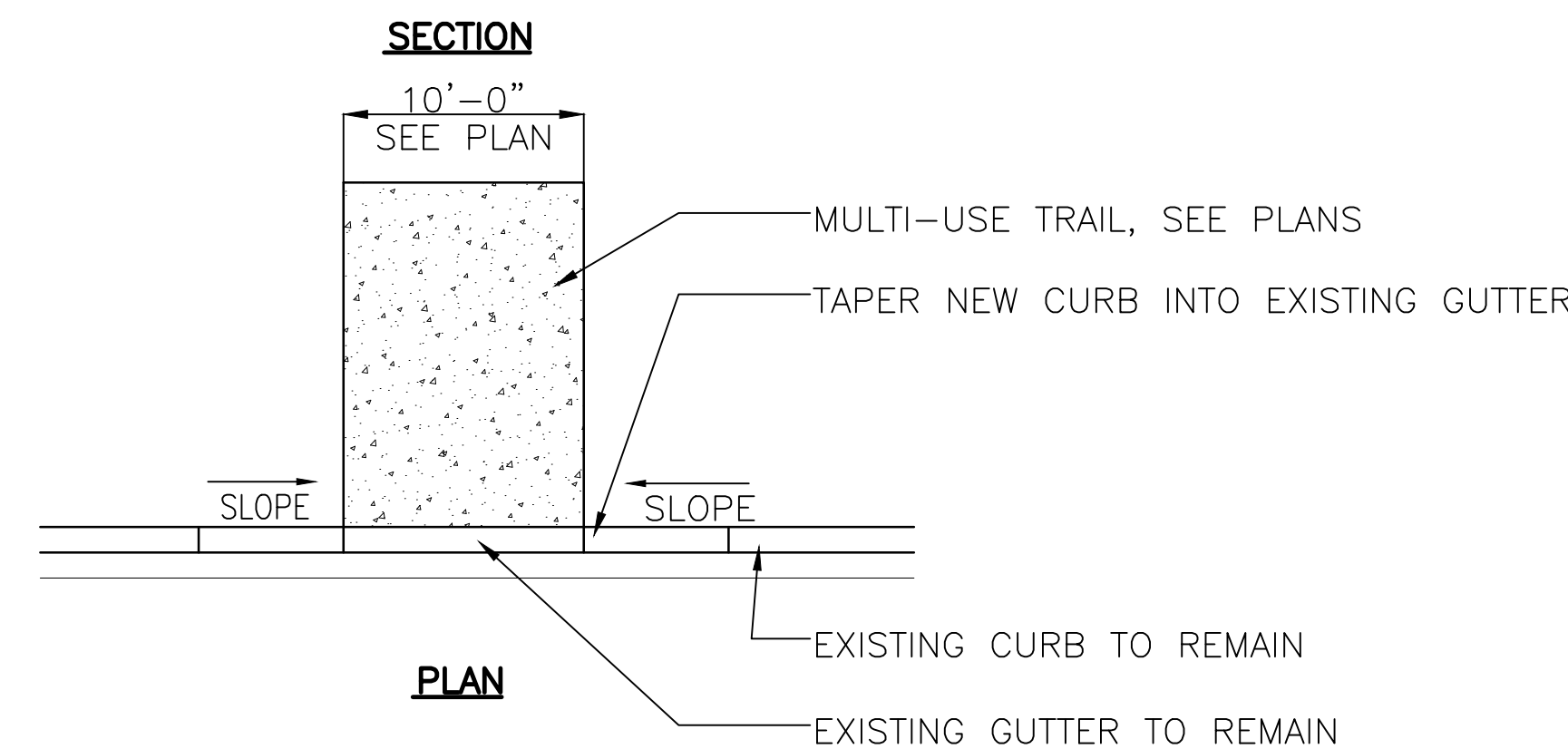
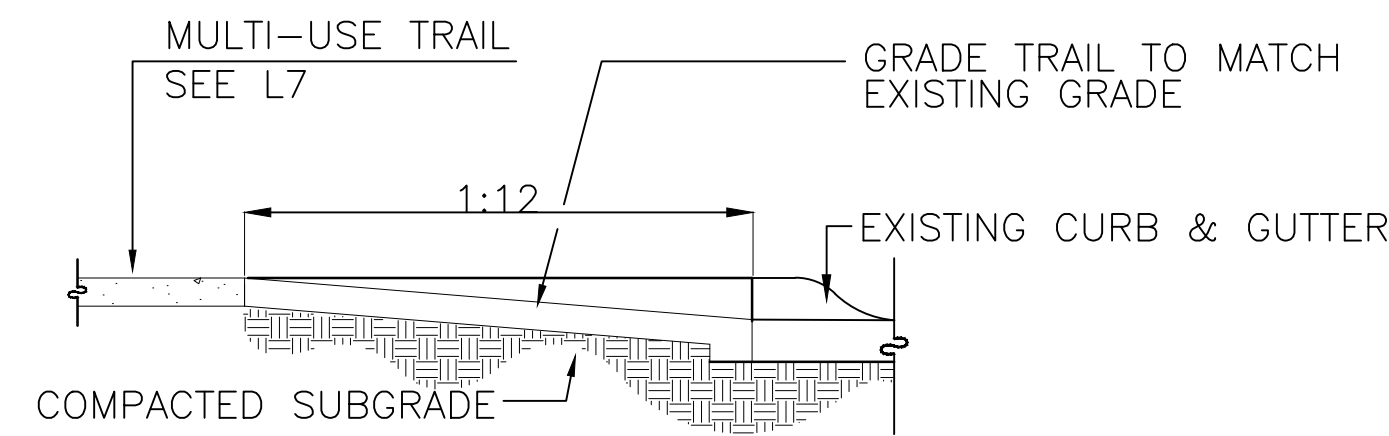
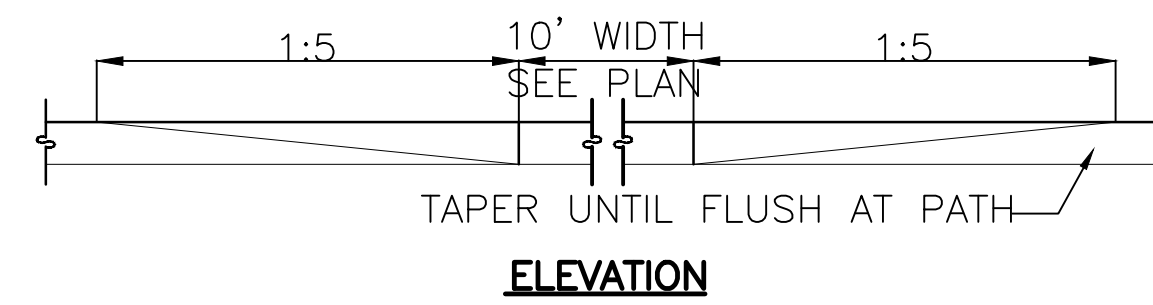

2
L7
CURB CUT DETAIL
SCALE: NTS

GENERAL GRADING NOTES:

1. CONTRACTOR IS RESPONSIBLE FOR VERIFYING ALL DATA PROVIDED IN THESE DRAWINGS. BASE DATA PROVIDED BY ANDREWS & BURGESS INC.
2. CONTRACTOR SHALL VERIFY ALL ELEVATIONS PRIOR TO CONSTRUCTION AND NOTIFY CITY LANDSCAPE ARCHITECT OF DISCREPANCIES.
3. IF DISCREPANCIES DEVELOP BETWEEN THE PROPOSED GRADES AS SHOWN ON THE PLAN AND THE EXISTING GROUND SURFACE, THE CONTRACTOR, WITH PRIOR APPROVAL FROM THE CITY LANDSCAPE ARCHITECT, SHALL MAKE GRADING ADJUSTMENTS NECESSARY TO MAINTAIN THE GENERAL INTENT OF THE DESIGN.
4. THE CONTRACTOR SHALL PROTECT ALL TREES, VEGETATION AND REFERENCE POINTS AS INDICATED ON THE DRAWINGS.
5. ALL PAVED AREAS SHALL BE STAKED IN THE FIELD AND APPROVED BY CITY LANDSCAPE ARCHITECT PRIOR TO INSTALLATION.
6. ALL WALKS SHALL HAVE A CROSS SLOPE
7. ALL WALKS SHALL NOT EXCEED 5%
8. CONTRACTOR IS RESPONSIBLE FOR ALL PAVED AREAS DAMAGED DURING CONSTRUCTION.
9. ALL GRADED AREAS INCLUDING SLOPES ARE TO BE SEEDED AS SOON AS POSSIBLE AFTER GRADING IS COMPLETED. SEED MIX SHALL BE APPROVED BY CITY LANDSCAPE ARCHITECT.
10. THE CONTRACTOR SHALL LOCATE ALL PROPOSED AND EXISTING UTILITIES PRIOR TO BEGINNING OF WORK. THE CONTRACTOR SHALL REPAIR ANY DAMAGE TO UTILITIES THAT ARE DISTURBED AS A RESULT OF THE WORK.
11. CONTRACTOR IS TO PROVIDE POSITIVE DRAINAGE AWAY FROM ALL STRUCTURES AND VERIFY THAT WATER IS BEING DEPOSITED INTO SWALES PROVIDED IN R.O.W.
12. CONTRACTOR IS TO INSPECT THE SITE BEFORE AND AFTER THE MULTI-USE PATH HAS BEEN INSTALLED TO ENSURE THAT THERE IS NO STANDING OR POUNDING WATER ON PATH.
13. CONTRACTOR IS TO INSTALL SCREENS OVER THE ENDS OF ALL CULVERT PIPES TO PREVENT OBJECTS, DEBRIS, AND ANIMALS FROM ENTERING THE ENDS OF THE PIPE.

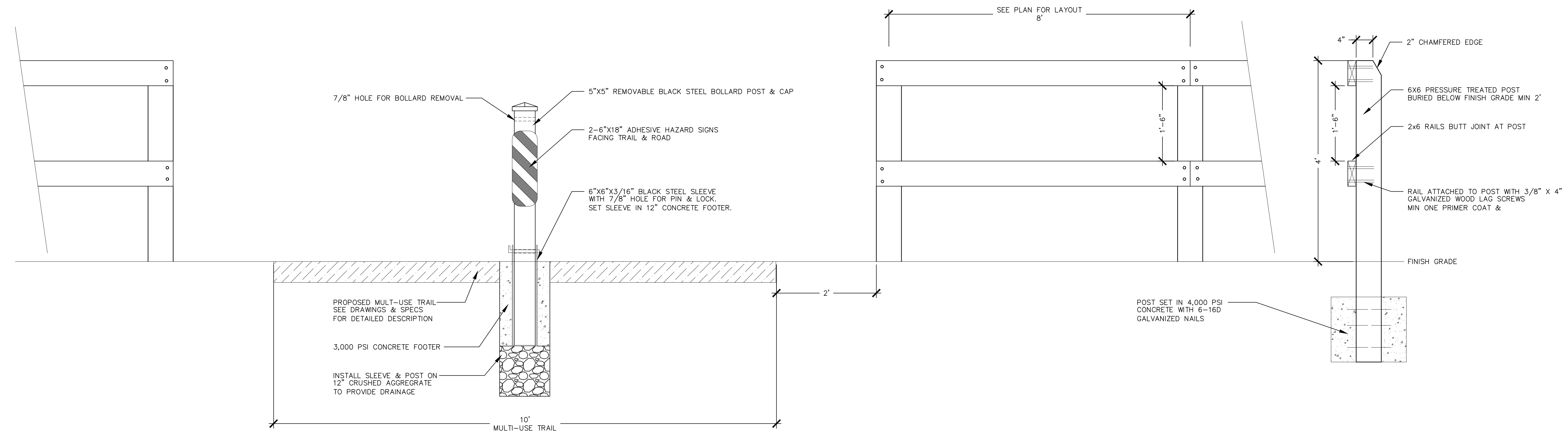

3
L7
WOODEN GATE ENTRY POINT
SCALE: NTS



CITY OF BEAUFORT

1911 Boundary Street
Beaufort, SC 29902
www.cityofbeaufort.org

Southside Park

Trail Details

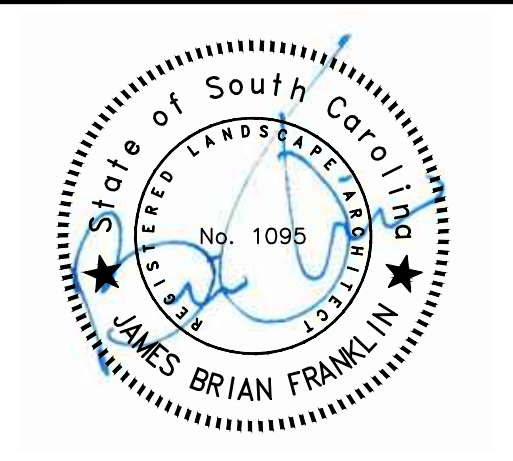

PROJECT NO.: 2170000
DATE DRAWN: 11.30.17
DRAWN BY: BF
CHECKED BY:
REVISED:

DATE	REVISIONS

This drawing is the exclusive property of the City of Beaufort. It may not be copied, reproduced, modified, published or used in any manner without written permission.

SHEET NUMBER:

L7
OF 8

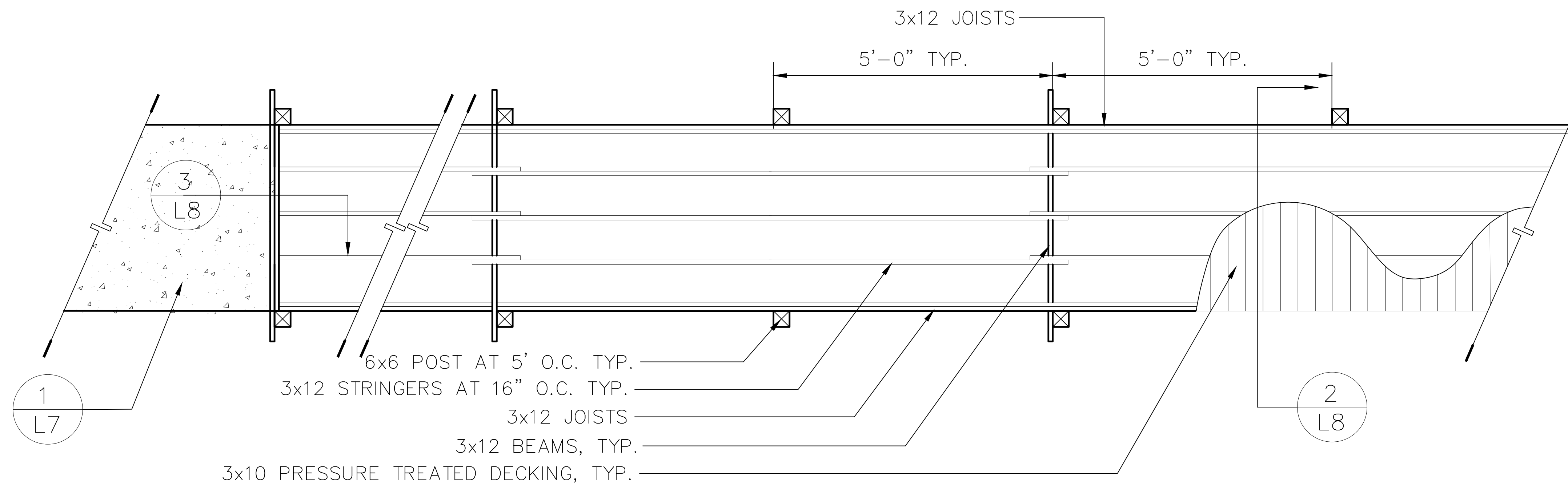

GENERAL PEDESTRAIN BRIDGE NOTES

- ALL CONSTRUCTION SHALL CONFORM TO THE CITY OF BEAUFORT CODE.
- DRAWINGS SHOW TYPICAL AND CERTAIN SPECIFIC CONDITIONS ONLY. FOR DETAILS NOT SPECIFICALLY SHOWN PROVIDE DETAILS SIMILAR TO THOSE SHOWN.
- VERIFY ALL EXISTING CONDITIONS, DIMENSIONS, AND ELEVATIONS BEFORE STARTING WORK. NOTIFY THE CITY LANDSCAPE ARCHITECT OF ANY DISCREPANCY.
- NOTIFY CITY LANDSCAPE ARCHITECT OF CONDITIONS ENCOUNTERED IN THE FIELD CONTRADICTORY TO THOSE SHOWN ON THE CONTRACT DOCUMENTS.
- UNLESS NOTED OTHERWISE, ALL TIMBER PILES SHALL BE SOUTHERN PINE CONFORMING TO ASTM D25. ALL TIMBER PILES SHALL BE CLEAN PEELED PILES.
- CONTRACTOR SHALL COORDINATE EQUIPMENT AND MATERIAL STORAGE AREAS WITH CITY OF BEAUFORT REPRESENTATIVE.
- THE CONTRACTOR IS SOLELY RESPONSIBLE FOR ALL FIELD ENGINEERING REQUIRED FOR HIS CONSTRUCTION. FURNISHING ALL LINE GRADES AND CONTROL POINTS.
- SPLICING OF THE PILES IS NOT PERMITTED.
- ANY PILE OUT OF PLUMB THAT EXCEEDS THE MAXIMUM PERMISSIBLE DEVIATION SHALL BE REMOVED AND RE-DRIVEN OR A NEW PILE SHALL BE DRIVEN TO REPLACE IT. REFER TO THE INSTALLATION SPECIFICATION FOR DRIVEN PILES BY PDCA. (PILE DRIVING CONTRACTORS ASSOCIATION, JANUARY 2017)
- FOR THE PROTECTION OF THE PILE HEAD, A 1" THICK STEEL PLATE SHALL BE INSERTED BETWEEN THE HEAD OF THE PILE AND THE HAMMER PLUNGER.
- ALL METAL HARDWARE (NUTS, BOLTS, WASHERS, ETC.) TO BE GALVANIZED PER ASTM A153 AND ASTM-A653 STANDARDS.
- ALL COSTS OF MATERIALS, EQUIPMENT, LABOR AND INCIDENTAL ITEMS NECESSARY TO COMPLETE THE WORK FOR THE TIMBER BOARDWALK SHALL BE INCLUDED IN THE LINEAR FOOT PRICE BID FOR THE TIMBER BOARDWALK-10' WIDE.
- ALL LUMBER AND TIMBER SHALL BE TREATED IN ACCORDANCE WITH AWPA C2 WITH CCA PRESERVATIVE.
- DRILL ALL HOLES STRAIGHT AND PERPENDICULAR TO THE BEARING SURFACE.
- COUNTER-BORE HOLES FOR BOLTS FOR COUNTER SINKING BOLT HEADS AND WASHERS.
- PRIOR TO ERECTION OF TIMBERS, COAT ALL CUT, BORED, DAPPED AND DAMAGED TIMBER SURFACES IN ACCORDANCE WITH AWPA M5.
- ALL TIMBER WORK TO BE PLUMB AND LEVEL WITH TIGHT JOINTS BETWEEN ALL MEMBERS.
- TIGHTEN BOLTS SUFFICIENTLY TO BRING ALL BEARING SURFACES IN TO CONTACT.
- COAT END GRAIN OF ALL EXPOSED VERTICAL TIMBERS WITH CCA PRESERVATIVE.
- STORE TIMBER UNDER COVER, ABOVE GROUND, AND KEEP FREE FROM DIRT, GREASE OR OTHER FOREIGN MATTER. STACK TIMBER IN A MANNER THAT WILL PREVENT LONG TIMBERS FROM SAGING OR BECOMING CROOKED. ERECT TIMBER WORK PLUMB AND LEVEL WITH TIGHT JOINTS BETWEEN ALL MEMBERS.

1 PEDESTRIAN BRIDGE DETAIL
SCALE: NTS

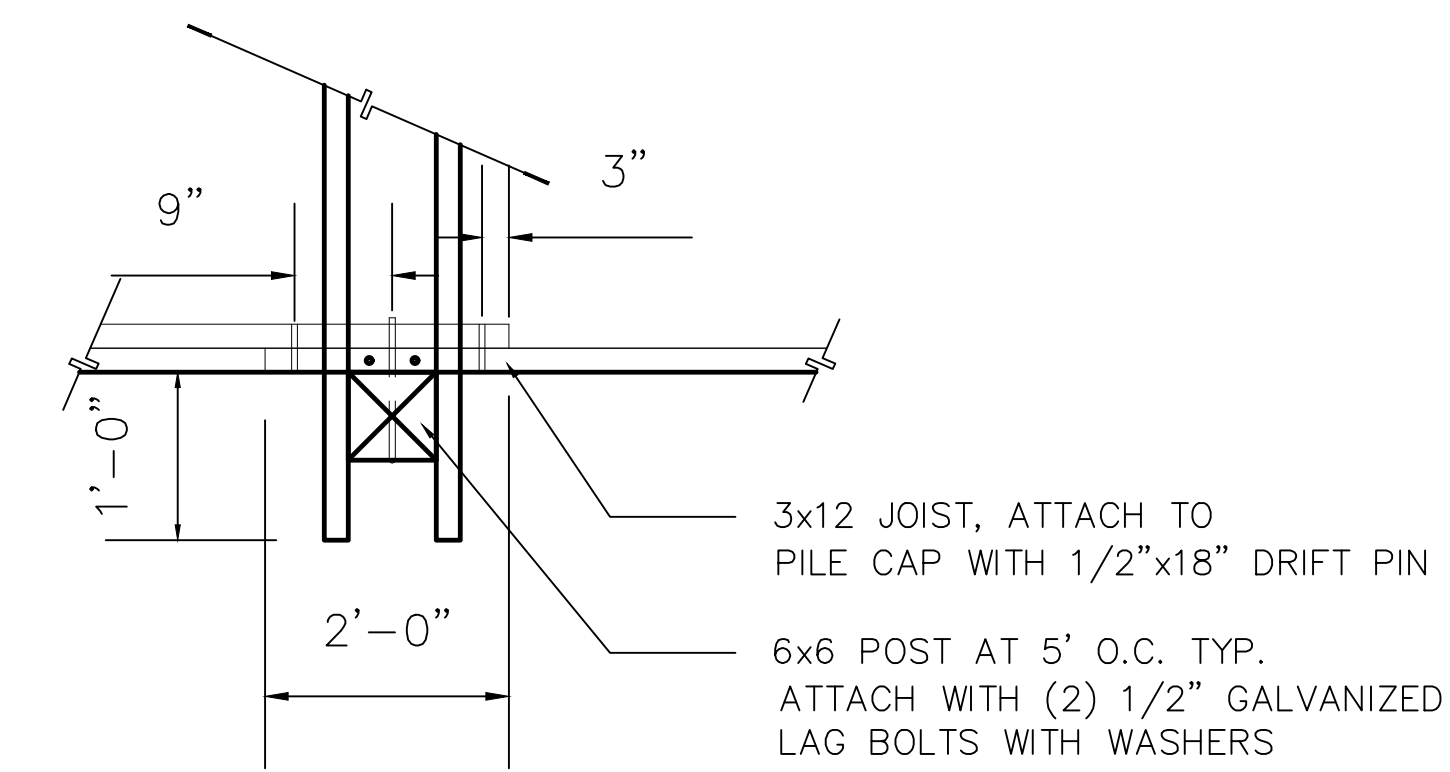

4 ENLARGED DETAIL
SCALE: NTS

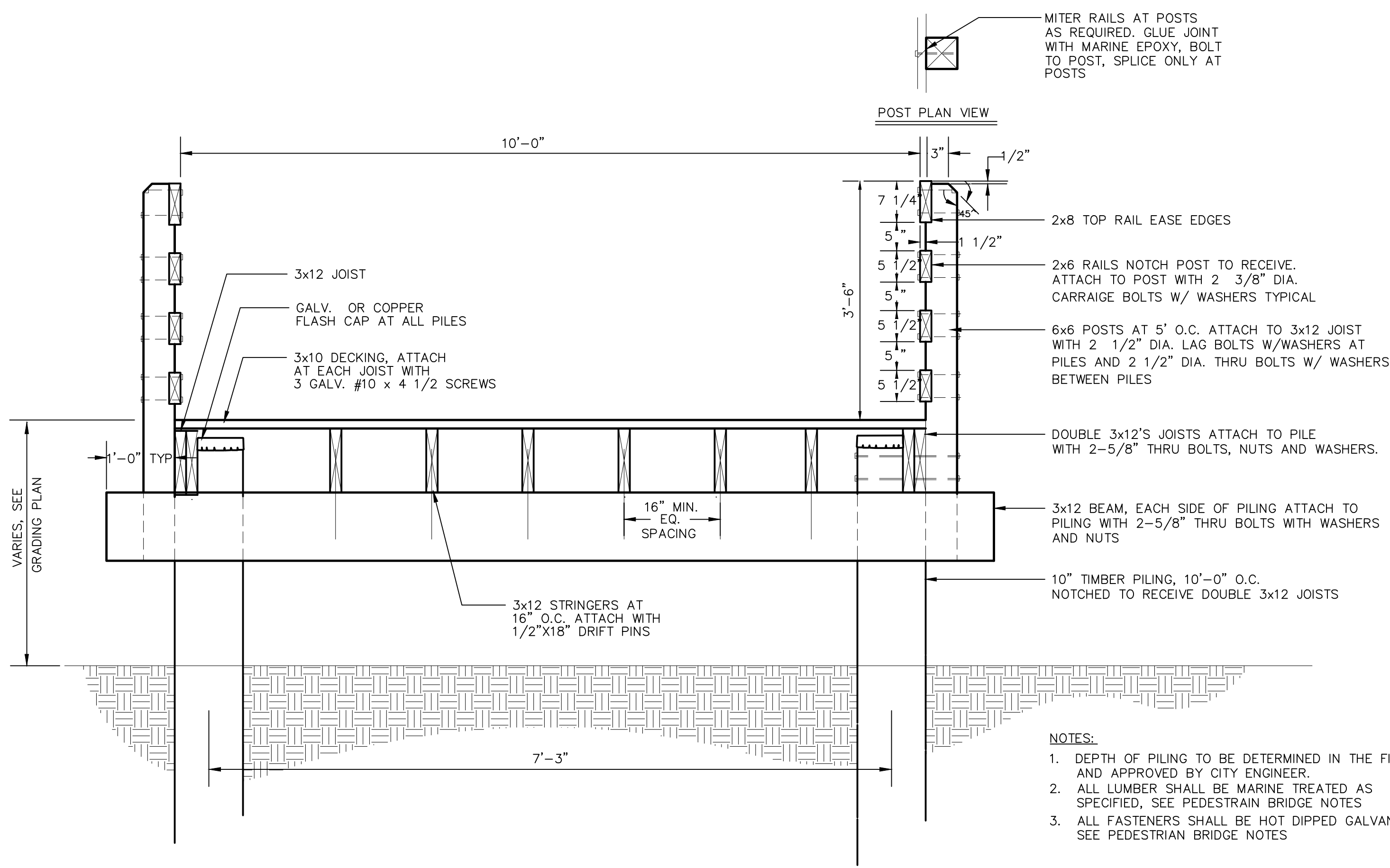

- NOTES:**
- DEPTH OF PILING TO BE DETERMINED IN THE FIELD AND APPROVED BY CITY ENGINEER.
 - ALL LUMBER SHALL BE MARINE TREATED AS SPECIFIED, SEE PEDESTRAIN BRIDGE NOTES
 - ALL FASTENERS SHALL BE HOT DIPPED GALVANIZED SEE PEDESTRAIN BRIDGE NOTES

2 PEDESTRIAN BRIDGE SECTION
SCALE: NTS

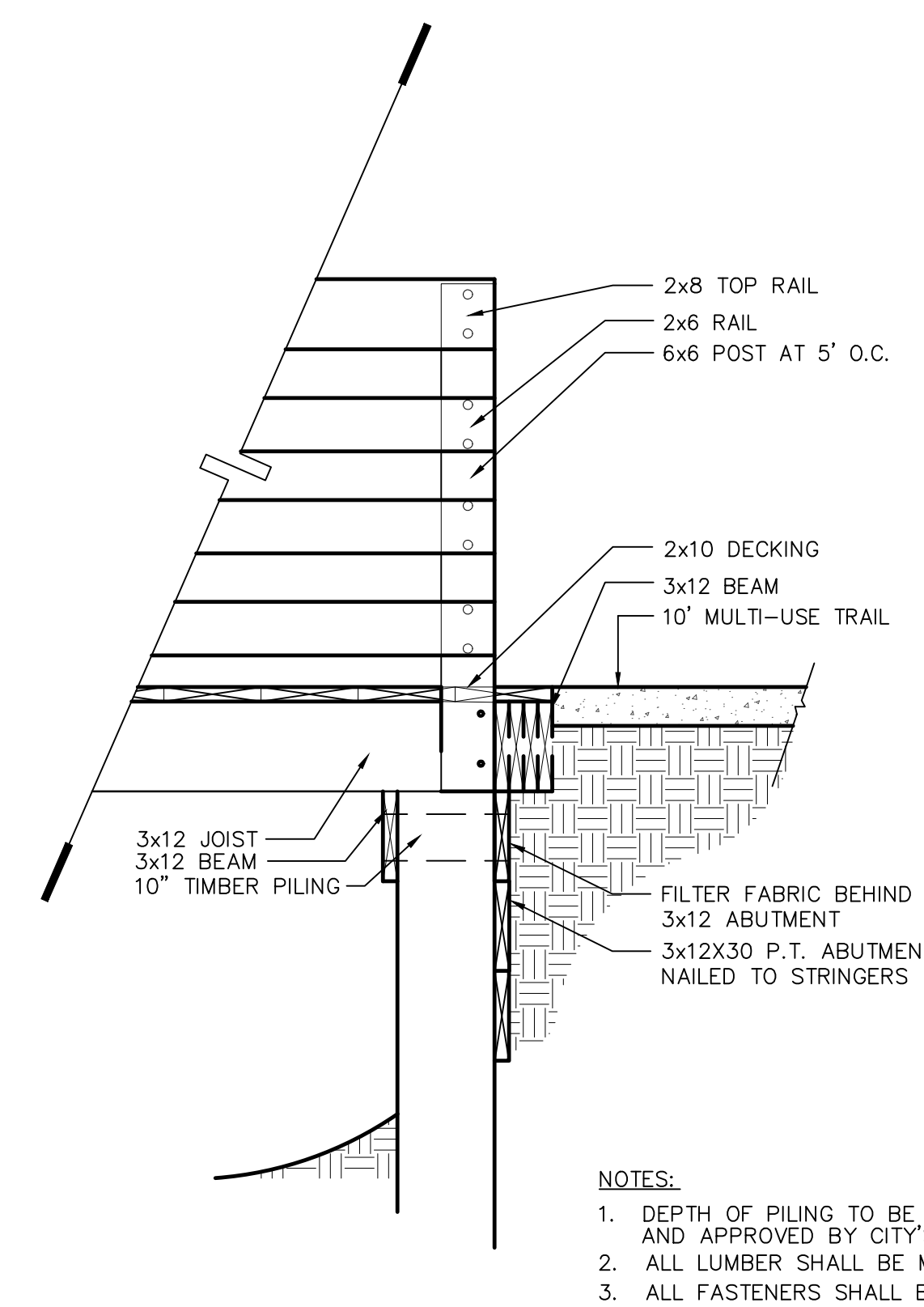

- NOTES:**
- DEPTH OF PILING TO BE DETERMINED IN THE FIELD AND APPROVED BY CITY'S ENGINEER.
 - ALL LUMBER SHALL BE MARINE TREATED, SEE NOTES
 - ALL FASTENERS SHALL BE HOT DIPPED GALVANIZED, SEE

3 PEDESTRIAN BRIDGE / MULTI-USE TRAIL SECTION
SCALE: NTS



CITY OF BEAUFORT

1911 Boundary Street
Beaufort, SC 29902
www.cityofbeaufort.org

Southside Park

Bridge Details

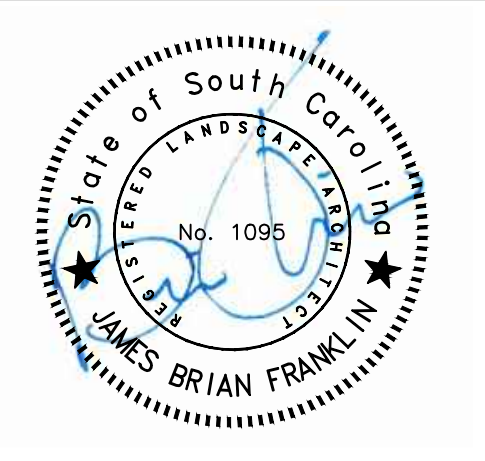

PROJECT NO.: 2170000
DATE DRAWN: 11.30.17
DRAWN BY: BF
CHECKED BY:
REVISED:

DATE	REVISIONS

This drawing is the exclusive property of the City of Beaufort. It may not be copied, reproduced, modified, published or used in any manner without written permission.

SHEET NUMBER:

L8
OF 8