

PARABOLIC CROWN
SECTION A-A

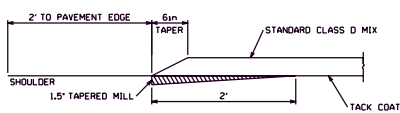

SHOULDER DETAIL FOR STREETS
WITHOUT CURBS
OR SPEED CUSHIONS ON ANY STREET

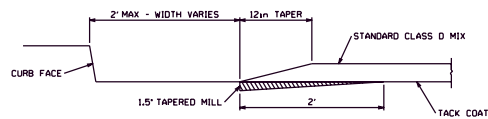

CURB DETAIL

SECTION B-B

NOTE:

1. 1.5" MILL OF ENTIRE FOOTPRINT OPTIONAL.
2. A TEMPLATE MUST BE USED FOR CONSTRUCTION TO ENSURE ASPHALT DEPTHS.
3. SPEED CUSHIONS SHOULD BE CONSTRUCTED WITH IDENTICAL PROFILE AND EDGE DETAILS, BUT A 7' FOOT WIDTH.

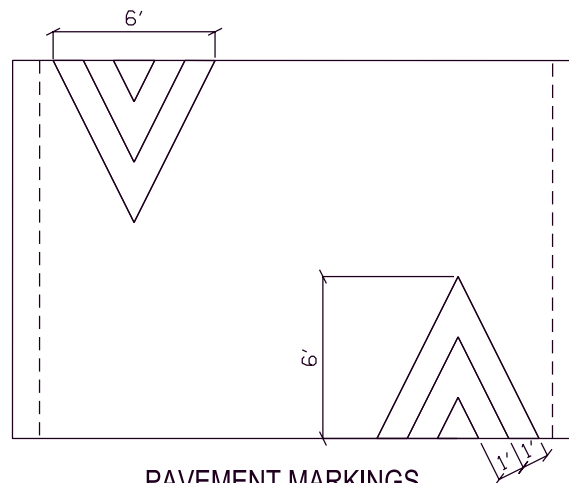

PAVEMENT MARKINGS

NOTE: INSTALL WITH CENTER OF TRIANGLE ALIGNED AS CLOSELY AS POSSIBLE WITH CENTER OF EACH TRAVEL LANE.

CITY OF KNOXVILLE
DEPARTMENT OF ENGINEERING

ASPHALT SPEED HUMP
DETAIL

DATE:	1/10/2019
DRAWN BY:	ZSR
CHECKED BY:	SF
APPROVED BY:	ZSR
SCALE:	VARIES

SHEET NUMBER