



## *Georgetown County, South Carolina*

129 Screven Street, Suite 239  
Post Office Drawer 421270  
Georgetown, SC 29442-4200  
(843) 545-3083 • Fax (843) 545-3500  
E-Mail • [purch@gtcounty.org](mailto:purch@gtcounty.org)  
Website • <http://www.gtcounty.org>

### ADDENDUM #1 TO Bid #23-020

BID NUMBER: 23-020

ISSUE DATE: Wedday, April 12, 2023

OPENING DATE: **Wed., April 26, 2023**

OPENING TIME: **3:00 PM ET**

Pre-Bid Conference/Site Inspection: [Independent-On Own]

#### **PROCUREMENT FOR: Repair/Replacement of Public Beach Access**

---

---

This addendum will amend **Bid #23-020, Repair/Replacement of Public Beach Access** originally issued on Friday, February 17, 2023. This clarification is being provided to all known and registered correspondents in response to questions received. All addenda and original bid documents are also available online at: [www.gtcounty.org](http://www.gtcounty.org), select "Bid Opportunities" from the Quick Links section.

---

**CHANGE:** See revised drawing S1.01 Driveover Plan attached to replace the one previously issued. This one is identical to #47 which was previously restored.

---

DRAWING NAME: C:\Users\mccormack\AppData\Local\Temp\AutoCAD\Drawings\2486232107.dwg 1/18/2022 12:38pm (mccormack)

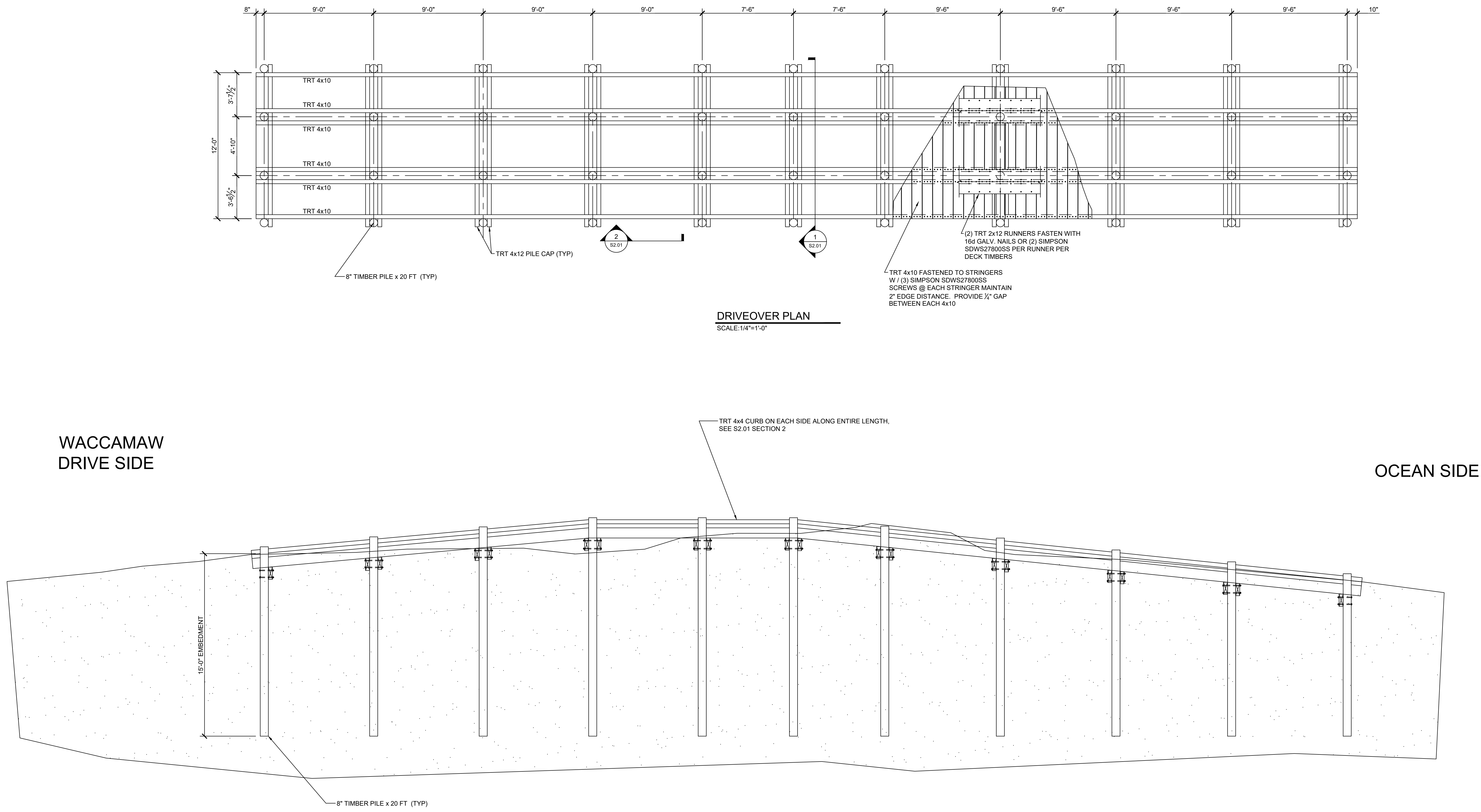

**DRIVEOVER PLAN**  
SCALE: 1/4"=1'-0"

**DRIVEOVER ELEVATION**  
SCALE: 1/4"=1'-0"

WACCAMAW  
DRIVE SIDE

OCEAN SIDE

**EARTHWORKS**  
planning and design consultants

11655 HIGHWAY 707  
MURRELLS INLET, SC 29576  
843.651.7903  
(FAX) 843.651.7903  
www.earthworksgroup.com

CERTIFICATE OF PROFESSIONAL ENGINEERING  
NO. 113022  
STEVEN S. MURPHY  
11/13/2022

CERTIFICATE OF PROFESSIONAL ENGINEERING  
NO. C01383  
THE EARTHWORKS GROUP, INC.  
NO. C01383

**REVISION SCHEDULE**

NO.	DATE	DESCRIPTION
1		<PRELIMINARY PLANS>
2		
3		
4		
5		
6		
7		
8		
9		
10		
11		
12		

**GEORGETOWN COUNTY DRIVEOVERS**

**DRIVEOVER STRUCTURE**

PREPARED FOR: ARC INC  
7711 BURGESS ROAD  
MURRELLS INLET, SC

PROJECT LOCATION: BEACH DRIVE OVER STRUCTURE  
GEORGETOWN, SC

PROJECT #: 221207.000  
DATE: 11/22/2022  
SCALE: AS NOTED  
DESIGNED BY: SGS  
DRAWN BY: RMM  
CHECKED BY: SGS

**S1.01**

ALL RIGHTS RESERVED. Disclaimer: The Earthworks Group is hereby known as EWT, Inc. The User agrees not to use this document in whole or part, for any purpose or project other than the project, which is the subject of this Agreement. User agrees to waive all claims against EWT, Inc. resulting in any way from unauthorized changes or reuse of this document by anyone other than EWT, Inc. In addition, User agrees to the fullest extent permitted by law, to indemnify and hold EWT, Inc. harmless from any damage, liability or cost, including reasonable attorney's fees and costs of defense arising from any damages, losses or expenses that EWT, Inc. or its any third party may incur in connection with this project. This Agreement is subject to the terms and conditions of the EWT, Inc. Standard Terms and Conditions of Use, which are available at www.earthworksgroup.com. The representation of use of this drawing without the architect/engineer's written consent is prohibited and any infringement is subject to legal action.

DRAWING NAME: C:\Users\micos\AppData\Local\Temp\AutoCAD\AutoCAD\2022\12\30\12301.dwg

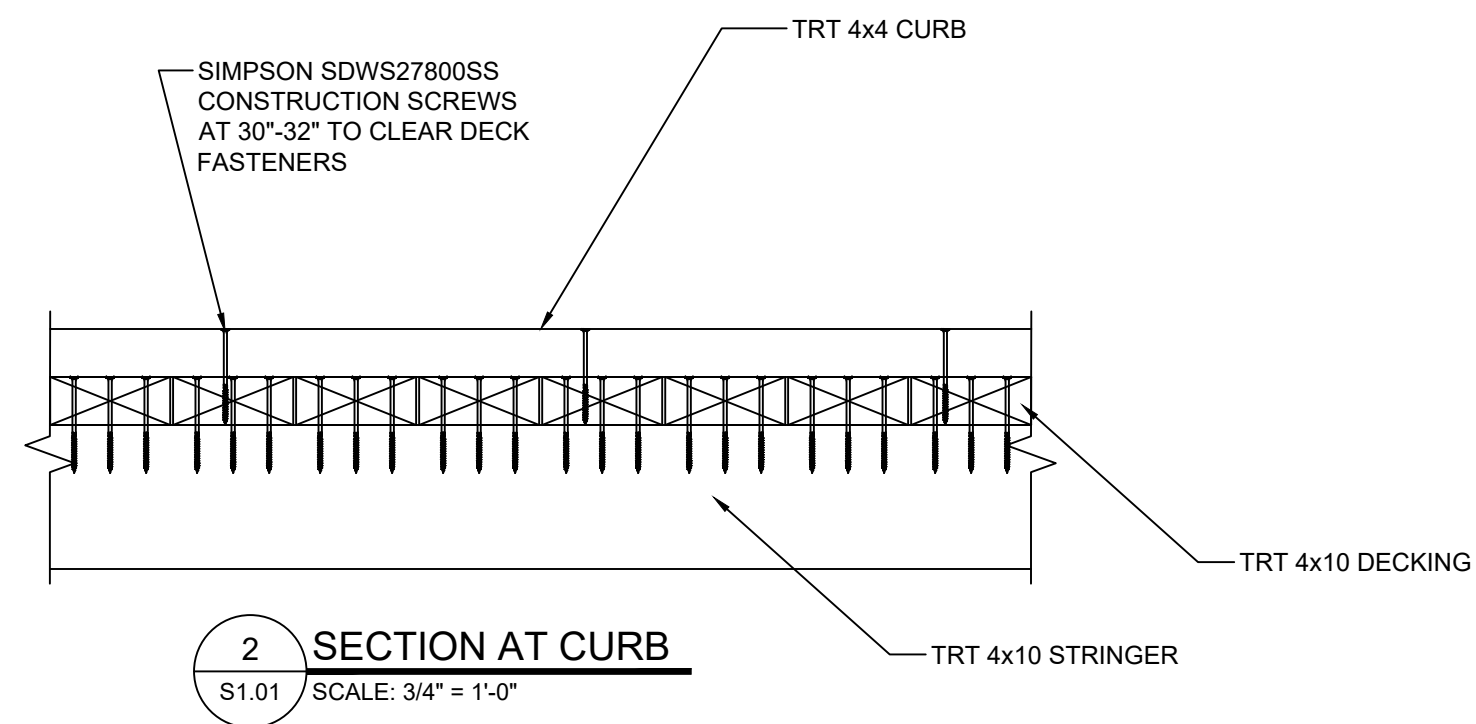

**2 SECTION AT CURB**  
S1.01 SCALE: 3/4" = 1'-0"

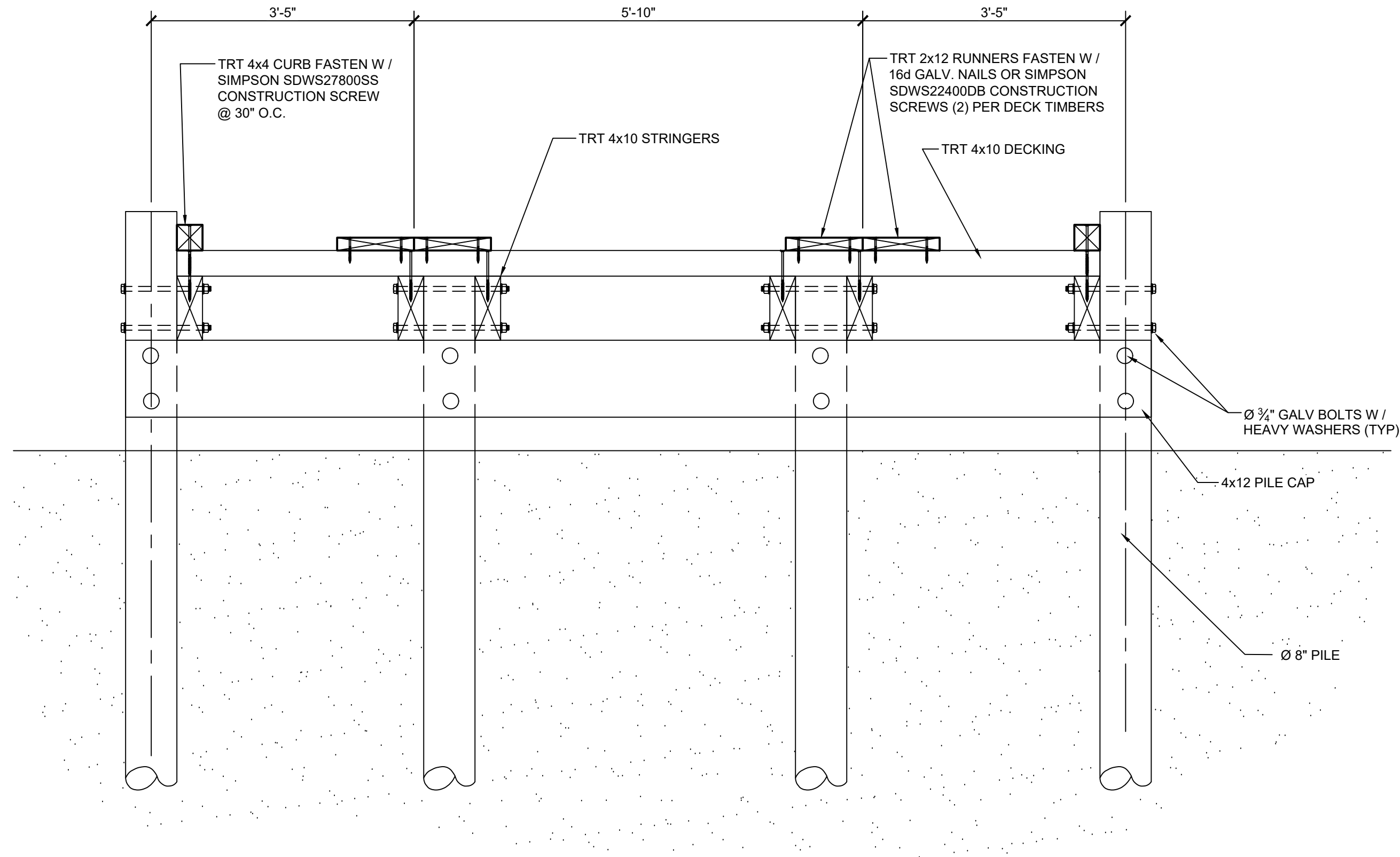

**1 SECTION THRU DRIVEOVER**  
S1.01 SCALE: 3/4" = 1'-0"

PROJECT #: 221207.000  
DATE: 11/22/2022  
SCALE: AS NOTED  
DESIGNED BY: SGS  
DRAWN BY: RMM  
CHECKED BY: SGS

GEORGETOWN COUNTY  
DRIVEOVERS  
STRUCTURAL DETAILS

PREPARED FOR: ARC INC  
7711 BURGESS ROAD  
MURRELLS INLET, SC  
PROJECT LOCATION: BEACH DRIVE OVER STRUCTURE  
GEORGETOWN, SC

REVISION SCHEDULE

NO.	DATE	DESCRIPTION
1	<DATE>	<PRELIMINARY PLANS>
2		
3		
4		
5		
6		
7		
8		
9		
10		
11		
12		

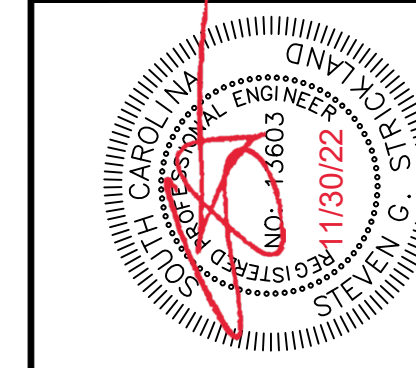
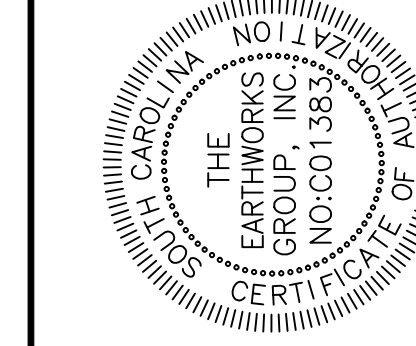

**EARTHWORKS**  
planning and design consultants  
11655 HIGHWAY 707  
MURRELLS INLET, SC 29576  
843.651.7900  
(FAX) 843.651.7903  
www.earthworksgroup.com

**S2.01**

ALL RIGHTS RESERVED. Disclaimer: The Earthworks Group is hereby known as EWI, Inc. The User agrees not to use this document in whole or part, for any purpose or project other than the project, which is the subject of this Agreement. User agrees to waive all claims against EWI, Inc. resulting in any way from unauthorized changes or reuse of this document by anyone other than EWI, Inc. In addition, User agrees to the fullest extent permitted by law, to indemnify and hold EWI, Inc. harmless from any damage, liability or cost, including reasonable attorney's fees and costs of defense arising from any damages, losses or expenses that EWI, Inc. or its any third party of the document without the prior written consent of EWI, Inc. or its purchaser. This drawing and the design therein, is the property of EWI, Inc. The reproduction or use of this drawing without the architect/engineer's written consent is prohibited and any infringement is subject to legal action.



STRUCTURAL NOTES

Table with 4 columns: GOVERNING CODE, 2018 INTERNATIONAL BUILDING CODE WITH SOUTH CAROLINA AMENDMENTS, LOADS ARE IN ACCORDANCE WITH ASCE 7-16. Rows include Risk Category, Dead Loads, Live Loads, Snow Loads, Wind Loads, Seismic Load Information, Geotechnical Information, Flood Design Data, and Rain Load.

GENERAL

- 1. THE STRUCTURE IS DESIGNED TO BE SELF-SUPPORTING AND STABLE AFTER THE BUILDING IS FULLY COMPLETED. IT IS SOLELY THE CONTRACTOR'S RESPONSIBILITY TO DETERMINE ERECTION PROCEDURES AND SEQUENCE, AND TO ENSURE THE STABILITY OF THE BUILDING AND ITS COMPONENT PARTS, AND THE ADEQUACY OF TEMPORARY OR INCOMPLETE CONNECTIONS, DURING ERECTION. THIS INCLUDES THE ADDITION OF ANY SHORING, SHEETING, TEMPORARY BRACING OR TIEDOWNS THAT MIGHT BE NECESSARY. SUCH MATERIAL IS NOT SHOWN ON THE DRAWINGS. IF APPLIED, THEY SHALL BE REMOVED AS CONDITIONS PERMIT. THE ENGINEER TAKES NO RESPONSIBILITY FOR CONSTRUCTION MEANS AND METHODS OR JOB SITE SAFETY DURING CONSTRUCTION. PROCESSING AND/OR APPROVING SUBMITTALS MADE BY THE CONTRACTOR WHICH MAY CONTAIN INFORMATION RELATED TO CONSTRUCTION METHODS OR SAFETY ISSUES, OR PARTICIPATION IN MEETINGS WHERE SUCH ISSUES MIGHT BE DISCUSSED, SHALL NOT BE CONSTRUED AS VOLUNTARY ASSUMPTION BY THE ENGINEER OF ANY RESPONSIBILITY FOR SAFETY PROCEDURES.

REINFORCED CONCRETE

- 1. MATERIALS:
1.a. SPECIFICATIONS: IN GENERAL, COMPLY WITH ACI 318-14 "SPECIFICATIONS FOR STRUCTURAL CONCRETE"
1.b. STRUCTURAL CONCRETE:
LOCATION Fc (PSI)
FOOTINGS 3,000
MONOLITHIC SLABS ON GRADE & ALL INTERIOR CONCRETE NOT OTHERWISE IDENTIFIED 3,500
RAISED STEMWALL SLABS & CONCRETE ON-GRADE, PIERS 3,000
BACKFILL BELOW FOOTINGS (MUD MAT) 2,000
ALL EXTERIOR CONCRETE NOT OTHERWISE IDENTIFIED 3,000
1.c. ALL DEFORMED REINFORCING BARS: Fy = 60,000 ASTM A-615 GRADE 60
1.d. MIXES: ALL CONCRETE MIXES SHALL BE DESIGNED BY THE SUPPLIER TO MEET THE REQUIREMENTS SET FORTH HEREIN.
1.d.1. SLUMP: MAXIMUM ALLOWABLE SLUMP FOR CONCRETE SHALL BE 4", UNLESS OTHERWISE NOTED OR APPROVED. IF HIGHER SLUMP IS DESIRED TO INCREASE WORKABILITY, CONTRACTOR SHALL CONSULT WITH CONCRETE SUPPLIER ABOUT USING A CONCRETE ADDITIVE THAT WILL INCREASE SLUMP WITHOUT INCREASING WATER/CEMENT RATIO OF THE CONCRETE. THE CONTRACTOR SHALL VERIFY THAT ANY CONCRETE ADDITIVES WILL NOT HAVE ANY DETRIMENTAL EFFECTS ON EMBEDDED ITEMS, FINISHES INDICATED ON PLANS, OR LIKELY FUTURE FINISHES.
1.e. FINISHING: FINISHING OF CONCRETE SHALL BE IN ACCORDANCE WITH ACI 301 (LATEST EDITION).
1.e.1. CURING: BEGINNING IMMEDIATELY AFTER PLACEMENT, CONCRETE SHALL BE PROTECTED FROM PREMATURE DRYING, EXCESSIVELY HOT OR COLD TEMPERATURES, AND MECHANICAL INJURY AND SHALL BE MAINTAINED WITH MINIMAL MOISTURE LOSS AT RELATIVELY CONSTANT TEMPERATURE FOR THE PERIOD NECESSARY FOR THE HYDRATION OF THE CEMENT AND HARDENING OF THE CONCRETE. THE MATERIALS AND METHODS OF CURING SHALL CONFORM TO ACI 301.
2. FIELD MANUAL: PROVIDE AT LEAST ONE COPY OF THE ACI FIELD REFERENCE MANUAL, SP-15, IN THE FIELD OFFICE AT ALL TIMES.
3. MISCELLANEOUS:
3.a. BENT BARS, IF REQUIRED, SHALL BE BENT PER MANUFACTURER RECOMMENDATIONS, UNLESS OTHERWISE APPROVED.
3.b. PROVIDE SUPPORTS AS REQUIRED TO MAINTAIN ALIGNMENT OF SCHEDULED REINFORCING.
3.c. GROUT UNDER COLUMN BASE PLATES SHALL BE NON-SHRINKING TYPE. THE USE OF LEVELING PLATES AT COLUMN BASES IS PROHIBITED. GROUT BELOW BEARING PLATES, SETTING PLATES AND COLUMN BASE PLATES IS TO BE INSTALLED ONLY AFTER THE STEEL IS PLUMBED.
4. SLABS:
4.a. CONCRETE SLABS ON GRADE SHALL BE CONSTRUCTED IN ACCORDANCE WITH ACI 302.1R-96 "GUIDE FOR CONCRETE".
4.b. CONTROL JOINTS SHALL BE SPACED IN INTERIOR SLABS ON GRADE AT A MAXIMUM OF 20 FEET ON CENTER AND IN EXTERIOR SLABS ON GRADE AT A MAXIMUM OF 10 FEET ON CENTER, UNLESS OTHERWISE NOTED.
4.c. CONTROL JOINTS SHALL BE PRODUCED USING CONVENTIONAL PROCESSES WITHIN 4 TO 12 HOURS AFTER THE SLAB HAS BEEN FINISHED. REINFORCING STEEL SHALL NOT EXTEND THROUGH THE CONTROL JOINT.

- 4.d. CONSTRUCTION JOINTS PERMITTED ONLY WHERE SHOWN OR AS APPROVED BY THE STRUCTURAL ENGINEER. CONSTRUCTION JOINTS ARE TO BE KEVED. KEYWAYS SHALL BE 1-1/2 INCHES DEEP x 1/3 MEMBER THICKNESS.
4.e. PROVIDE 6 MIL POLYETHYLENE VAPOR BARRIER BETWEEN SUBGRADE AND CONCRETE SLAB.
4.f. TREAT SOIL FOR TERMITES PRIOR TO PLACEMENT OF CONCRETE.
4.g. PREPARE SITE BY REMOVING ORGANIC/EXPANSIVE SOILS AND COMPACTING TO 95% PROCTOR DRY DENSITY.
4.h. SLAB FINISHES:
4.h.1. ALL OFFICE SPACES, RETAIL, RESIDENTIAL AND SIMILAR SLABS SHALL HAVE MACHINE FINISH WITH 1/8" PER 10'-0" TOLERANCE.
4.h.2. ALL EXTERIOR, WET SURFACE, DRIVEWAYS, SIDEWALKS AND SIMILAR SLABS SHALL BE FINISHED WITH ROUGH NON-SKID SURFACE (BROOM FINISH). BRUSH LINES IN THE FINISH SHALL BE PARALLEL TO THE DIRECTION OF SLOPE.
4.i. THE CONCRETE SLAB ON GRADE HAS BEEN DESIGNED USING A SUBGRADE MODULUS OF K=250 PCI AND A DESIGN LOADING OF 2,000 PSF. THE STRUCTURAL ENGINEER OF RECORD IS NOT RESPONSIBLE FOR DIFFERENTIAL SETTLEMENT, SLAB CRACKING OR OTHER FUTURE DEFECTS RESULTING FROM UNREPORTED CONDITIONS MITIGATING THE ABOVE ASSUMPTIONS.
4.j. REINFORCEMENT FOR SLAB ON GRADE SHALL BE PLACED AT A LOCATION BETWEEN THE CENTER AND UPPER THIRD OF THE SLAB.
5. OPENINGS:
5.a. OPENINGS SHOWN ARE FOR BIDDING PURPOSES ONLY. COORDINATE THEIR EXACT SIZES AND LOCATIONS WITH HVAC, PLUMBING, AND OTHER REQUIREMENTS BEFORE PROCEEDING WITH WORK.
5.b. IF ANY OPENING NOT SHOWN ON THE PLANS IS REQUIRED, SECURE APPROVAL OF THE STRUCTURAL ENGINEER BEFORE PROCEEDING
5.c. PROVIDE TWO #5 BARS AROUND ALL SLAB OPENINGS, EXTENDING 2 FEET BEYOND OPENING IN EVER DIRECTION, UNLESS NOTED OTHERWISE. OPENINGS NOT EXCEEDING 16 INCHES x 16 INCHES MAY BE SLEEVED AS REQUIRED BY WORKING THE REINFORCING STEEL AROUND THEM.
6. FOOTINGS AND PIERS:
6.a. INSTALL DOWELS IN FOOTINGS TO MATCH VERTICAL PIER OR WALL REINFORCING STEEL.
6.b. PROVIDE CORNER BARS AT FOOTING CORNERS TO MATCH HORIZONTAL REINFORCING. MINIMUM LAP LENGTH WITH HORIZONTAL REINFORCING STEEL = 35 BAR DIAMETERS.
6.c. BACKFILL AGAINST BOTH SIDES OF WALLS EQUALLY UNTIL THE LOWER ELEVATION IS ATTAINED.
6.d. PROVIDE MINIMUM 18 INCH THICK LAYER OF GRANULAR BACKFILL FULL HEIGHT OF ALL FOUNDATION WALLS.
6.e. CAST IN CONTINUOUS DOVE TAIL ANCHOR SLOTS ON VERTICAL SURFACES WHERE MASONRY ABUTS, 16 INCHES ON CENTER FOR PARALLEL MASONRY SURFACES. INSTALL AT CENTERLINE OF MASONRY FOR PERPENDICULAR MASONRY SURFACES.
6.f. PROVIDE LEAN CONCRETE UNDER FOUNDATIONS FOR ACCIDENTAL OVER EXCAVATION, SOFT SPOTS, AND TRENCHES.
6.g. VENTILATING FOUNDATION WALL OPENINGS SHALL BE WITHIN 3 FEET OF EACH CORNER OF THE BUILDING. AREA OF OPENINGS SHALL BE NOT LESS THAN 1 SQ. FT. FOR EACH 150 SQ. FT. OF UNDER FLOOR SPACE AREA.
7. SPLICES: UNLESS OTHERWISE NOTED, MINIMUM LAP SPLICE LENGTHS TO BE AS FOLLOWS:
REINFORCING STEEL LAP LENGTH
VERTICAL BARS (INCLUDING DOWELS) 30 BAR DIAMETERS
HORIZONTAL BARS IN SLABS & FOOTINGS 30 BAR DIAMETERS
8. CONCRETE COVER: UNLESS OTHERWISE NOTED, DETAIL REINFORCING TO PROVIDE CONCRETE COVER AS FOLLOWS:
STEEL LOCATION CONCRETE COVER
CONCRETE CAST AGAINST AND PERMANENTLY EXPOSED TO EARTH 3 INCHES
CONCRETE EXPOSED TO EARTH OR WEATHER:
#5 BARS AND SMALLER 1-1/2 INCHES
OTHERS 2 INCHES
PILE CAPS 2-1/2 INCHES

C. STRUCTURAL LUMBER

- 1. SPECIFICATIONS: UNLESS SPECIFICALLY SHOWN OTHERWISE, DESIGN, FABRICATION AND ERECTION SHALL BE GOVERNED BY THE LATEST EDITION OF THE FOLLOWING:
1.a. NATIONAL DESIGN SPECIFICATION FOR WOOD CONSTRUCTION.
1.b. U.S. PRODUCT STANDARD PS1
2. MATERIALS:
2.a. STRUCTURAL LUMBER (INCLUDING BEARING AND EXTERIOR WALL STUDS): MINIMUM PROPERTIES OF SPRUCE-PINE-FIR #2, ALLOWABLE STRESSES PER THE NATIONAL DESIGN SPECIFICATION SUPPLEMENT, LATEST EDITION, 19% MAXIMUM MOISTURE CONTENT. OTHER ACCEPTABLE SPECIES INCLUDE HEM-FIR, SOUTHERN PINE AND DOUGLAS FIR-LARCH.
2.b. STRUCTURAL SHEATHING (PLYWOOD & OSB):
2.b.1. FOR ROOFS: OSB OR C-D PLUGGED, 5-PLY, EXPOSURE 1, 7/16" THICK.
2.b.2. FOR WALLS: OSB OR C-D PLUGGED, 5-PLY EXPOSURE 1, 7/16" THICK.
2.b.3. FOR WALLS NOT AT SHEAR WALLS: OSB 7/16" THICK WITH PANEL INDEX W24, EXPOSURE 1.
2.c. ALL FRAMING EXPOSED TO THE WEATHER OR IN CONTACT WITH MASONRY OR CONCRETE SHALL BE PRESSURE TREATED IN ACCORDANCE WITH THE AMERICAN WOOD PRESERVERS ASSOCIATION SPECIFICATIONS.
2.c.1. WHERE POSSIBLE, ALL EXPOSED CUTS AND HOLES SHOULD BE COMPLETED BEFORE TREATMENT.
2.c.2. CUTS AND HOLES DUE TO ON-SITE FABRICATION SHALL BE BRUSHED WITH TWO COATS OF COPPER NAPHTHENATE SOLUTION CONTAINING A MINIMUM OF 2% METALLIC COPPER IN SOLUTION (PER AWWA STD. M4).
3. CONNECTIONS:
3.a. JOISTS & RAFTERS TO SIDES OF BEAMS: 16 GA. GALVANIZED STANDARD JOIST HANGERS, UNLESS OTHERWISE NOTED.
3.b. RAFTERS AND TRUSSES TO TOPS OF WALLS AND BEAMS: 18 GA. GALVANIZED HURRICANE ANCHORS.
3.c. PLYWOOD TO ROOF TRUSSES OR RAFTERS: NAILED WITH RING-SHANK NAILS. SEE STRUCTURAL WOOD PANEL NOTES BELOW.
3.c.1. PROVIDE PLYWOOD CLIPS AT MID-SPAN OF PLYWOOD BETWEEN SUPPORTS, OR
3.c.2. PROVIDE BLOCKING BETWEEN ROOF FRAMING AT PLYWOOD EDGES AND NAIL WITH EDGE NAILING PATTERN.
3.d. ALL METAL CONNECTIONS SHALL BE SIMPSON OR USP.
3.e. ALL CONNECTORS TO BE INSTALLED PER MANUFACTURER'S INSTRUCTIONS.
3.e.1. CONTACT ENGINEER WITH QUESTIONS PERTAINING TO HOLDDOWNS SPECIFIED ON PLANS.
3.f. STUD COLUMNS SHALL BE SECURED WITH TWO ROWS OF 3 INCH 10d NAILS SPACED 24 INCHES ON CENTER, UNLESS OTHERWISE NOTED.
3.g. LOAD VALUES FOR 8d, 10d, 16d AND 20d DESIGNATIONS IN THE FASTENER SCHEDULES THROUGHOUT THESE PLANS REFER TO COMMON WIRE NAILS, UNLESS OTHERWISE NOTED. NAILS SHALL CONFORM TO A RECOGNIZED NATIONAL STANDARD, SUCH AS ASTM F1667, AS PRESCRIBED BY THE MODEL BUILDING CODES.

D. DRIVEN PILES:

THE CONTRACTOR SHALL APPOINT A COMPETENT INSPECTOR QUALIFIED BY EXPERIENCE AND TRAINING. THE INSPECTOR SHALL BE PRESENT AT ALL TIMES DURING PILE DRIVING OPERATIONS AND SHALL INSPECT ALL WORK IN CONNECTION WITH THE INSTALLATION OF THE PILES.

THE INSPECTOR SHALL KEEP THE FOLLOWING RECORDS FOR EACH PILE:

- A. TYPE OF PILE
B. SIZE OF PILE
C. HAMMER MAKE, TYPE, SIZE, WEIGHT, AND FALL OF RAM
D. RATED BLOWS PER MINUTE AND ENERGY PER BLOW
E. DRIVING RECORD FOR THE FULL LENGTH OF THE PILE; BLOWS PER FT.
F. DRIVEN LENGTH BELOW CUTOFF
G. PILE TIP ELEVATION
H. PILE CUTOFF ELEVATION
THE RECORD SHALL BE KEPT UP-TO-DATE IN A NEAT AND LEGIBLE MANNER AND SHALL BE AVAILABLE FOR REVIEW BY THE ENGINEER. A COPY OF THE RECORD SHALL BE PROVIDED TO THE ENGINEER AT THE COMPLETION OF EACH DAY'S WORK.

QUALITY ASSURANCE:

MANUFACTURER'S CERTIFICATION; SUBMIT THE COPIES OF MANUFACTURE CERTIFICATION THAT THE PILING COMPLIES WITH THE SPECIFIED REQUIREMENTS.

TIMBER PILES PRESERVATIVE TREATMENT: THE CONTRACTOR SHALL BE RESPONSIBLE FOR THE QUALITY OF THE TREATED WOOD

PRODUCTS. AWWA QCIP QUALITY MARK AWWA ND-1, AWWA ND-4 WILL BE ACCEPTED AS EVIDENCE OF COMPLIANCE WITH

DELIVERY, STORAGE, AND HANDLING, STORE PILES IN ACCORDANCE WITH AWA MA.

PROVIDE STANDARD CLASS B SOUTHERN PINE CLEAN-PEELED PILES CONFORMING TO ASTM D 25. PILES SHALL BE IN ONE PIECE. SPLICES WILL NOT BE PERMITTED. EACH TREATED PILE SHALL BE BRANDED BY THE PRODUCER, IN

ALL PILES SHALL BE A MINIMUM OF 45 FEET LONG. MINIMUM TIP DIAMETER SHALL BE 8 INCHES. MINIMUM BUTT DIAMETER SHALL BE 12 INCHES (MEASURED 3 FEET FROM THE BUTT).

TREAT PILES BY THE FULL-CELL PRESSURE PROCESS IN ACCORDANCE WITH AWWA U1 (COMMODITY SPECIFICATION A, USE CATEGORY 4C) FOR ROUND TIMBER PILES, AWWA U1 (COMMODITY SPECIFICATION A, USE CATEGORY 4B) FOR SAWN TIMBER PILES, AWWA C3 FOR MARINE PILING.

E. TIMBER POSTS:

REFERENCED STANDARD

THE PUBLICATIONS LISTED BELOW FORM A PART OF THIS SPECIFICATION TO THE EXTENT REFERENCED. THE PUBLICATIONS ARE REFERRED TO IN THE TEXT BY THE BASIC DESIGNATION ONLY.

AWPA U1 1990 PILES, PRESSURE TREATMENT AWWA M4. 1990 CARE OF PRESSURE TREATMENT AWWA M6 1988 BRANDS USED ON FOREST PRODUCTS AWWA MP-4 1988 MARINE PILING PRESSURE TREATED WITH WATERBORNE WATERS

AWPA QCIP 1988 PRESSURE TREATED LUMBER, TIMBERS PLYWOOD CONSTRUCTION POLES, PILES AND SPECIAL PURPOSE USE PRODUCTS
INSPECTION AND ACCEPTANCE OF PILES ACCEPTANCE WILL BE ON THE BASIC CERTIFICATION, INSPECTION OF MATERIALS PROPOSED TO BE INCORPORATED IN THE WORK, RECEIPT OF, PILE DRIVING RECORDS, AND INSPECTION OF THE COMPLETED PRODUCT.

POST INSTALLATION FOR WALKWAYS AND STAIRS
THE CONTRACTOR SHALL AUGER ALL POSTS INTO THE SAND TO THE MINIMUM DEPT SPECIFIED ON THE PLANS. ALL POSTS SHALL BE A MINIMUM OF 16 FEET UNLESS A LONGER LENGTH IS REQUIRED DUE TO DUNE HEIGHT. CONTRACTOR SHALL INSPECT ALL WORK IN CONNECTION WITH THE INSTALLATION OF THE POSTS.

MANUFACTURER'S CERTIFICATION; SUBMIT THE COPIES OF MANUFACTURE CERTIFICATION THAT THE PILING COMPLIES WITH THE SPECIFIED REQUIREMENTS.

QUALITY ASSURANCE:

TIMBER POST PRESERVATIVE TREATMENT: THE CONTRACTOR SHALL BE RESPONSIBLE FOR THE QUALITY OF THE TREATED WOOD PRODUCTS. AWWA QCIP QUALITY MARK AWWA ND-1, AWWA ND-4 WILL BE ACCEPTED AS EVIDENCE OF COMPLIANCE WITH DELIVERY, STORAGE, AND HANDLING, STORE POSTS IN ACCORDANCE WITH AWA MA.

ALL POSTS SHALL BE A MINIMUM OF 16 FEET LONG.
TREAT POSTS BY THE FULL-CELL PRESSURE PROCESS IN ACCORDANCE WITH AWWA U1 (COMMODITY SPECIFICATION A, USE CATEGORY 4C) FOR
TREAT PILES TO A RETENTION RATE OF 2.5 LB. CUJ/FT.

TREATMENT REQUIREMENTS FOR MARINE CONSTRUCTION:

Table with 3 columns: BELOW WATER MEMBERS, FRESH WATER, SALT WATER. Rows include SAWN PILES, WALLERS, SHEET PILES, CROSS BRACING.

Table with 3 columns: SPLASH ZONE MEMBERS, FRESH WATER, SALT WATER. Rows include SPLIT PILE CAPS & STRINGERS.

Table with 3 columns: ABOVE WATER MEMBERS, FRESH WATER, SALT WATER. Rows include DECKING, HANDRAILS, WALLCAPS.

Table with 3 columns: ABOVE WATER MEMBERS, FRESH WATER, SALT WATER. Rows include DECKING, HANDRAILS, WALLCAPS.

Table with 3 columns: ABOVE WATER MEMBERS, FRESH WATER, SALT WATER. Rows include DECKING, HANDRAILS, WALLCAPS.

Table with 3 columns: ABOVE WATER MEMBERS, FRESH WATER, SALT WATER. Rows include DECKING, HANDRAILS, WALLCAPS.

Table with 3 columns: ABOVE WATER MEMBERS, FRESH WATER, SALT WATER. Rows include DECKING, HANDRAILS, WALLCAPS.

Table with 3 columns: ABOVE WATER MEMBERS, FRESH WATER, SALT WATER. Rows include DECKING, HANDRAILS, WALLCAPS.

Table with 3 columns: ABOVE WATER MEMBERS, FRESH WATER, SALT WATER. Rows include DECKING, HANDRAILS, WALLCAPS.

Table with 3 columns: ABOVE WATER MEMBERS, FRESH WATER, SALT WATER. Rows include DECKING, HANDRAILS, WALLCAPS.

Table with 3 columns: ABOVE WATER MEMBERS, FRESH WATER, SALT WATER. Rows include DECKING, HANDRAILS, WALLCAPS.

Table with 3 columns: ABOVE WATER MEMBERS, FRESH WATER, SALT WATER. Rows include DECKING, HANDRAILS, WALLCAPS.

Table with 3 columns: ABOVE WATER MEMBERS, FRESH WATER, SALT WATER. Rows include DECKING, HANDRAILS, WALLCAPS.

Table with 3 columns: ABOVE WATER MEMBERS, FRESH WATER, SALT WATER. Rows include DECKING, HANDRAILS, WALLCAPS.

Table with 3 columns: ABOVE WATER MEMBERS, FRESH WATER, SALT WATER. Rows include DECKING, HANDRAILS, WALLCAPS.

Table with 3 columns: ABOVE WATER MEMBERS, FRESH WATER, SALT WATER. Rows include DECKING, HANDRAILS, WALLCAPS.

Table with 3 columns: ABOVE WATER MEMBERS, FRESH WATER, SALT WATER. Rows include DECKING, HANDRAILS, WALLCAPS.

Table with 3 columns: ABOVE WATER MEMBERS, FRESH WATER, SALT WATER. Rows include DECKING, HANDRAILS, WALLCAPS.

Table with 3 columns: ABOVE WATER MEMBERS, FRESH WATER, SALT WATER. Rows include DECKING, HANDRAILS, WALLCAPS.

Table with 3 columns: ABOVE WATER MEMBERS, FRESH WATER, SALT WATER. Rows include DECKING, HANDRAILS, WALLCAPS.

Table with 3 columns: ABOVE WATER MEMBERS, FRESH WATER, SALT WATER. Rows include DECKING, HANDRAILS, WALLCAPS.

Table with 3 columns: ABOVE WATER MEMBERS, FRESH WATER, SALT WATER. Rows include DECKING, HANDRAILS, WALLCAPS.

Table with 3 columns: ABOVE WATER MEMBERS, FRESH WATER, SALT WATER. Rows include DECKING, HANDRAILS, WALLCAPS.

Table with 3 columns: ABOVE WATER MEMBERS, FRESH WATER, SALT WATER. Rows include DECKING, HANDRAILS, WALLCAPS.

Table with 3 columns: ABOVE WATER MEMBERS, FRESH WATER, SALT WATER. Rows include DECKING, HANDRAILS, WALLCAPS.

Table with 3 columns: ABOVE WATER MEMBERS, FRESH WATER, SALT WATER. Rows include DECKING, HANDRAILS, WALLCAPS.

Table with 3 columns: ABOVE WATER MEMBERS, FRESH WATER, SALT WATER. Rows include DECKING, HANDRAILS, WALLCAPS.

Table with 3 columns: ABOVE WATER MEMBERS, FRESH WATER, SALT WATER. Rows include DECKING, HANDRAILS, WALLCAPS.

Table with 3 columns: ABOVE WATER MEMBERS, FRESH WATER, SALT WATER. Rows include DECKING, HANDRAILS, WALLCAPS.

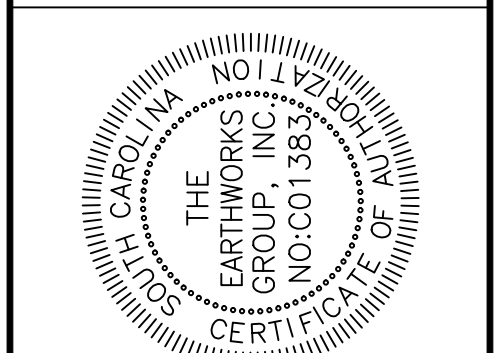
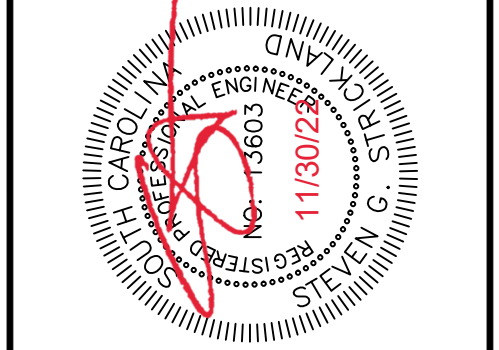

REVISION SCHEDULE table with columns: NO., DATE, DESCRIPTION, BY. Includes entries for PRELIMINARY PLANS.

Table with columns: PROJECT #, DATE, SCALE, DESIGNED BY, DRAWN BY, CHECKED BY. Values include 221207/000, 11/22/2022, AS NOTED, SGS, RMM, SGS.

Table with columns: PROJECT #, DATE, SCALE, DESIGNED BY, DRAWN BY, CHECKED BY. Values include 221207/000, 11/22/2022, AS NOTED, SGS, RMM, SGS.

GEORGETOWN COUNTY DRIVEOVERS STRUCTURAL NOTES
PREPARED FOR: ARC INC, 1711 BURGESS ROAD, MURRELLS INLET, SC
PROJECT LOCATION: BEACH DRIVE OVER STRUCTURE, GEORGETOWN, SC

S3.01





## ADDENDUM ACKNOWLEDGEMENT

### Bid #23-020 Repair/Replacement of Public Beach Access Mandatory Submittal Form

To be returned with the final proposal submission to Georgetown County.

COMPANY NAME: \_\_\_\_\_

- Addendum #1 Received Date: \_\_\_\_\_ Initialed By: \_\_\_\_\_
- Addendum #2 Received Date: \_\_\_\_\_ Initialed By: \_\_\_\_\_
- Addendum #3 Received Date: \_\_\_\_\_ Initialed By: \_\_\_\_\_
- Addendum #4 Received Date: \_\_\_\_\_ Initialed By: \_\_\_\_\_
- Addendum #5 Received Date: \_\_\_\_\_ Initialed By: \_\_\_\_\_
- Addendum #6 Received Date: \_\_\_\_\_ Initialed By: \_\_\_\_\_