



ROBERT G. CAMPBELL & ASSOCIATES, L.P.

7523 Taggart Lane
Knoxville, TN 37938
(865) 947-5996
Fax (865) 947-7556

2540 Sand Pike Blvd., Suite 3
Pigeon Forge, TN 37863
(865) 366-2516
Fax (865) 947-7556

ADDENDUM #2

ISSUED SEPTEMBER 17, 2020 FOR BIDDERS OF

**MARLOW CONVENIENCE CENTER
RGCA PROJECT NO. 19701
BID NO. 2103**

The purpose of the subject Addendum No. 2 is to: A) Provide updated contract documents, B) Provide answers to questions that have been asked, and C) reschedule the date for opening of bids

CONTRACT DOCUMENTS

1. Revised Page 1 of C-520 Agreement between Owner and Contractor
A request was made to increase the contract time from 60 days to 90 days for substantial completion. The number of days has been increased. The convenience center operations will be temporarily moved to the parking lot at the corner of Ford Road and Oliver Springs Hwy during construction. For convenience to the public, the time for this temporary operation should be kept to a minimum. For this reason, it is highly encouraged and requested that every effort be made to end the temporary setup by December 18, 2020.
2. Revised Page 3 of C-410 Bid Form
3. Revised Page 10 of C-800 Supplemental Conditions
4. Revised Plan Sheets 3, 4, & 7
5. Revised Bid Opening Date to Tuesday, September 29, 2020 at 10:00 am

QUESTIONS

- 1) What is the compactor pad thickness? (Sections show 7 and 8 inches.) *The compactor pad thickness is to be 8 inches.*
- 2) Does sawcut item pay for all cutting? Ie., electrical trenches, cuts for storm and sewer install and compactor pads. *Yes, the sawcut is for removal of existing concrete for installation of storm, utilities, and compactor pads.*

- 3) Specs refer to a geotechnical report. Will you provide it? *A geotechnical study has not been done, see revised page from Supplementary Conditions.*
- 4) If unsuitable soils are encountered, is removal and replacement incidental? *Grading and undercutting are expected to be minor incidental work. Anticipated costs should be included in the appropriate unit prices. Final grading and topsoil are to be included in unit price for minor seeding and stabilization around the edges of the site.*
- 5) Is concrete that will be require replacement for storm, sewer and electrical installation paid for under new concrete item. *Yes, this square footage is included in the quantity for new concrete.*
- 6) What other water quality unit can be used in lieu of the Aqua-Swirl AS-2? *Hydro International FDHC GA, or other equivalent structures may be used. A typical detail is attached.*
- 7) Please provide detail of the dowel on 15 foot centers required by the special provisions. *See detail on revised Plan Sheet 7*
- 8) The extruded curb detail doesn't quite match the overlay thickness. Does it need modified? *See revised curb detail.*

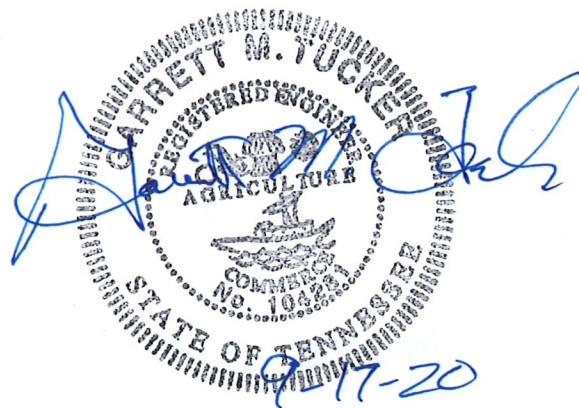

END OF ADDENDUM

**AGREEMENT
BETWEEN OWNER AND CONTRACTOR
FOR CONSTRUCTION CONTRACT (STIPULATED PRICE)**

THIS AGREEMENT is by and between Anderson County (“Owner”) and _____ (“Contractor”).

Owner and Contractor hereby agree as follows:

ARTICLE 1 – WORK

1.01 Contractor shall complete all Work as specified or indicated in the Contract Documents. The Work is generally described as follows:

ARTICLE 2 – THE PROJECT

2.01 The Project, of which the Work under the Contract Documents is a part, is generally described as follows: Marlow Convenience Center

ARTICLE 3 – ENGINEER

3.01 The Project has been designed by Robert G. Campbell & Associates, L.P.

3.02 The Owner has retained Robert G. Campbell & Associates, L.P. (“Engineer”) to act as Owner’s representative, assume all duties and responsibilities, and have the rights and authority assigned to Engineer in the Contract Documents in connection with the completion of the Work in accordance with the Contract Documents.

ARTICLE 4 – CONTRACT TIMES

4.01 *Time of the Essence*

A. All time limits for Milestones, if any, Substantial Completion, and completion and readiness for final payment as stated in the Contract Documents are of the essence of the Contract.

4.02 *Contract Times: Days*

A. The Work will be substantially completed within 90 days after the date when the Contract Times commence to run as provided in Paragraph 4.01 of the General Conditions, and completed and ready for final payment in accordance with Paragraph 15.06 of the General Conditions within 120 days after the date when the Contract Times commence to run.

4.03 *Liquidated Damages*

A. Contractor and Owner recognize that time is of the essence as stated in Paragraph 4.01 above and that Owner will suffer financial and other losses if the Work is not completed and Milestones not achieved within the times specified in Paragraph 4.02 above, plus any extensions thereof allowed in accordance with the Contract. The parties also recognize the delays, expense, and difficulties involved in proving in a legal or arbitration proceeding the actual loss suffered by Owner if the Work is not completed on time. Accordingly, instead of

ARTICLE 5 – BASIS OF BID

5.01 Bidder will complete the Work in accordance with the Contract Documents for the following price(s):

| ITEM NO. | EST. QTY. | UNIT | DESCRIPTION | UNIT PRICE | EXTENDED PRICE |
|---|-----------|------|---|------------|----------------|
| 105-01 | 1 | LS | Construction Stakes, Lines and Grades | | |
| 201-01 | 1 | L.S. | Mobilization | | |
| 502-04.01 | 236 | LF | Saw Cutting Existing Concrete / Asphalt | | |
| 502-03.13 | 516 | SY | Concrete / Pavement Removal | | |
| 209-99.91 | 1 | LS | Erosion Control | | |
| | | | | | |
| Overlay Ford Road & Entrance (2" Surface Coat) | | | | | |
| 411-02.11 | 85 | Tons | ACS Mix (PG64-22) Grading E (2" Thick) | | |
| Widen Entrance & Ford Road (Full Pavement Depth) | | | | | |
| 303-01 | 35 | Tons | Mineral Aggregate, Type A Base, Grading D (8" Thick) | | |
| 307-01.08 | 12 | Tons | Asphaltic Concrete Mix (PG64-22) (BPMB-HM) (3" Thick) | | |
| 411-02.11 | 8 | Tons | ACS Mix (PG64-22) Grading E (2" Thick) | | |
| 902-00 | 1 | LS | 30' Long 12" Wide 3" Thick Grading E Asphalt Speed Hu | | |
| 795-14.07 | 1 | EA | Concrete Vault (1000 Gallon Tank) | | |
| 610-10.45 | 4 | EA | Compactor Drains | | |
| 607-02.30 | 5 | LF | 15" HDPE | | |
| 611-01.02 | 1 | EA | Manhole, > 4'-8' Depth | | |
| 611.09-02 | 2 | EA | Re-Work Existing Catch Basin | | |
| 630-01.16 | 6 | EA | 6" Concrete Bollard / Guard Post | | |
| 702-01.02 | 125 | LF | Concrete Curb | | |
| 730-05.01 | 1 | LS | Electrical Work - Installed Complete | | |
| | | | | | |
| Two (2) Compactor Pads | | | | | |
| 701-02.02 | 1650 | SF | Concrete Compactor Pads (Heavy Duty) | | |
| Overlay Existing Concrete (4") | | | | | |
| 701-01.02 | 4780 | SF | 4" Concrete Overlay | | |
| New Concrete Area (6" Normal Duty) | | | | | |
| 701-02 | 5190 | SF | New Concrete Drive | | |
| | | | | | |
| 707-01.11 | 460 | LF | Chain Link Fence (6 Foot) With Privacy Screening | | |
| 707-01.13 | 3 | EA | Gate - Chain Link Fence 6 Foot With Privacy Screening | | |
| 713-16.20 | 1 | EA | Sign (Stop) | | |
| 713-16.21 | 1 | EA | Sign (Handicap) | | |
| 716-99.50 | 1 | LS | Striping / Pavement Markings | | |
| 797-05.51 | 18 | LF | 6" D.I. Gravity Sewer OFT - 6FT Depth | | |
| 202-06.02 | 1 | LS | Relocate Operations Building | | |
| 801-01 | 1 | LS | Seeding (With Mulch) | | |
| 920-18.05 | 1 | EA | Water Quality Treatment Unit | | |
| 611-42.02 | 1 | EA | Area Drain Catch Basin | | |
| 793-13.07 | 50 | LF | 4" Schedule 40 PVC | | |
| | | | | | |
| | | | Total of Unit Price Bid | | |

Total of Unit Price Bid = \$ _____

make all geotechnical data available. Note that a typical general purpose geotechnical report, usually prepared primarily to assist in the design of the project, often contains not only factual data but also opinions, interpretations, and even speculation regarding the Site's subsurface conditions. **Such a geotechnical report is not suitable to be adopted or identified as a GDR.**

Although it is preferable that a GBR be comprehensive with respect to subsurface conditions, in some cases a GBR will establish baselines for a portion of a project, but will not address all subsurface issues. For example, the GBR may establish baseline subsurface conditions along the route of a pipeline, but be silent with respect to conditions underlying an associated pump building. Also, in some cases a project will involve both subsurface construction as well as building modifications or other tasks unrelated to geotechnical investigations, analysis, or interpretations. The SC/GBR provisions that follow retain certain differing site condition provisions of the General Conditions, in part because these may be needed for situations that are outside the scope of the GBR. As noted previously, these SC/GBR provisions contain locations for (1) identifying known reports and drawings regarding the subsurface conditions (a mandatory obligation), and (2) identifying Technical Data upon whose accuracy Contractor may rely (necessary in some but not all GBR projects, depending on the scope of the GBR and GDR documents).

If a GBR is used, then include the following GBR Supplementary Conditions, and do not use either of the Paragraphs SC-5.03 above:

SC/GBR-5.03 and 5.04. Delete Paragraphs 5.03 and 5.04 of the General Conditions in their entireties and replace with the following provisions:

SC/GBR-5.03 Subsurface and Physical Conditions

A. Reports and Drawings: The Supplementary Conditions hereby identify:

1. those reports known to Owner of explorations and tests of subsurface conditions at or adjacent to the Site (other than any Geotechnical Data Report or Geotechnical Baseline Report), and Technical Data contained in such reports. Such reports are as follows:
 - a. N/A – No report available
2. those drawings known to Owner of physical conditions relating to existing surface or subsurface structures at the Site (except Underground Facilities), and Technical Data contained in such drawings. Such drawings are as follows: N/A
 - a. Drawings dated N/A
 - (2) None of the contents of such drawings is Technical Data on whose accuracy Contractor may rely.
3. Contractor may examine copies of reports and drawings identified immediately above that were not included with the Bidding Documents at

N/A

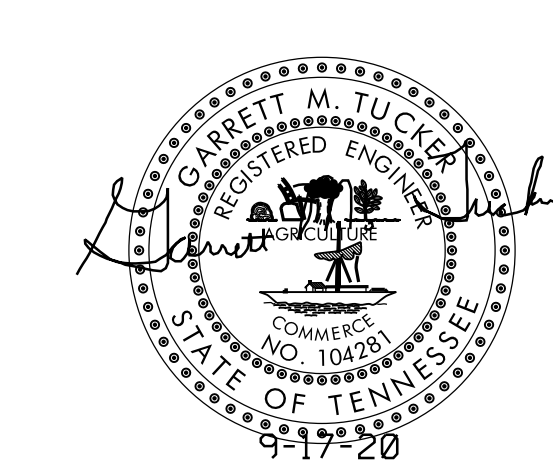
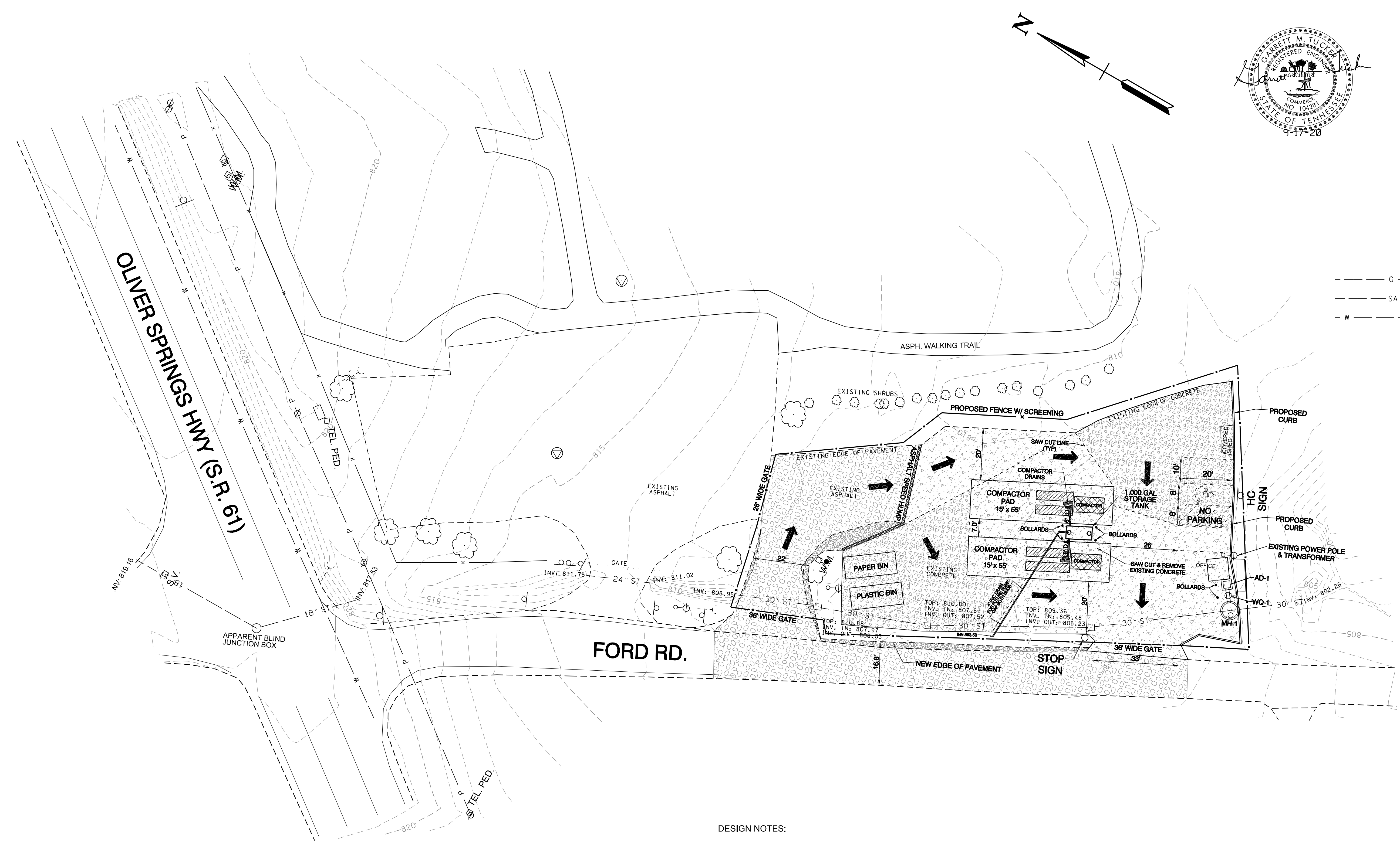

LEGEND

| | | |
|--------|-----------------|----------------------|
| ○ EIP | IRON PIN FOUND | |
| PIPE | PIPE FOUND | |
| □ G.V. | GAS VALVE | |
| □ W.M. | WATER METER | |
| ⊙ | MANHOLE | |
| ⊥ | SIGN | |
| □ W.V. | WATER VALVE | |
| ⊗ | FIRE HYDRANT | |
| ⊕ P/T | POWER/TELEPHONE | |
| ⋯ | GUY WIRE | |
| --- | G | GAS LINE (TYP) |
| --- | SA | SANITARY SEWER (TYP) |
| --- | W | WATER LINE (TYP) |

| | |
|--|---------------------------|
| | OVERLAY EXISTING PAVEMENT |
| | NEW PAVEMENT |
| | OVERLAY EXISTING CONCRETE |
| | NEW CONCRETE |
| | CONCRETE COMPACTOR PAD |

- NOTES:
- EXISTING MONUMENTS AS SHOWN. ALL OTHERS SET BY RGC&A.
 - EXISTING CONTOURS FROM TOPOGRAPHIC SURVEY. (NAVD 1988)
 - LOCATIONS OF UNDERGROUND UTILITIES SHOWN ARE APPROXIMATE. THERE MAY BE OTHER UTILITIES NOT SHOWN. PRIOR TO ANY EXCAVATION, THE OWNER AND/OR CONTRACTOR IS RESPONSIBLE FOR CONTACTING THE LOCAL UTILITY AUTHORITIES FOR EXACT LOCATIONS AND DEPTHS.
 - CONTRACTOR IS RESPONSIBLE FOR ALL TRENCH SAFETY PRACTICES.
 - EROSION CONTROL MEASURES SHOWN ON OTHER SHEETS ARE A MINIMUM. THE CONTRACTOR IS RESPONSIBLE FOR CONTROL OF EROSION ON SITE. ADDITIONAL ITEMS MAY BE REQUIRED.
 - APPLY TEMPORARY SEEDING WHENEVER GRADING OPERATIONS ARE TEMPORARILY HALTED FOR OVER 14 DAYS AND FINAL GRADING OF EXPOSED SURFACES IS TO BE COMPLETED WITHIN ONE YEAR.
 - APPLY TEMPORARY SEEDING TO SOIL STOCKPILES.
 - APPLY PERMANENT SEEDING WHENEVER GRADING OPERATIONS ARE COMPLETED AND ALL CONSTRUCTION OPERATIONS WILL NOT IMPACT THE DISTURBED AREA. APPLY PERMANENT SEEDING TO ALL NON-CONSTRUCTION AREAS WHICH SHOW SIGNS OF EXCESSIVE EROSION.
 - THE CONTRACTOR SHALL HAVE A STAMPED AND SIGNED COPY OF THIS PLAN ON SITE AT ALL TIMES DURING CONSTRUCTION
 - NO SLOPES SHALL BE STEEPER THAN 2H:1V

- DESIGN NOTES:
- TWO (2) NEW CONCRETE COMPACTOR PADS TO BE INSTALLED WITH COLLECTOR DRAINS.
 - EXISTING CONCRETE TO BE OVERLAID WITH 4" LIFT. SEE DETAILS AND SPECIFICATIONS.
 - NEW CONCRETE DRIVE TO BE CONSTRUCTED AS SHOWN.
 - NEW 6" CONCRETE CURB TO BE INSTALLED ALONG LOWER END OF SITE.
 - EXISTING CATCH BASINS TO BE RAISED WITH NEW LIDS AND GRATES.
 - CONCRETE TRAFFIC-RATED SEPTIC TANK TO BE INSTALLED FOR STORAGE OF EFFLUENT FROM COMPACTOR DRAINS.
 - WATER QUALITY TREATMENT UNIT TO BE INSTALLED FOR TREATMENT OF STORMWATER RUNOFF.
 - TRAFFIC FLOW TO BE GENERALLY CLOCKWISE AS SHOWN. ENTRANCE TO BE WIDENED AS SHOWN.
 - WIDENING OF FORD ROAD TO BE CONDUCTED.

OWNER/DEVELOPER:
 ANDERSON COUNTY, TENNESSEE
 MAYOR TERRY FRANK
 GEOFF TRABALKA
 ANDERSON COUNTY SOLID WASTE COORDINATOR
 100 NORTH MAIN STREET
 ROOM 127
 CLINTON, TN
 (865) 463-6845

ENGINEER:
 ROBERT G. CAMPBELL & ASSOC., L.P.
 7523 TAGGART LANE
 KNOXVILLE, TN, 37938
 PHONE: 865-947-5996

CLT # 087
 PARCEL 217.01
 TOTAL AREA: 3.78 ACRES
 DISTURBED AREA : 0.50 ACRES
 DEED REFERENCE:
 DB 1143 PG 235

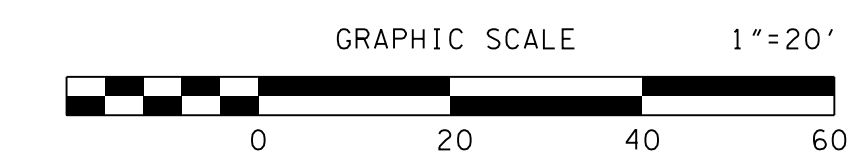

L:\ANDERSON\1970\1970_Sheets.dgn 9/17/2020 11:54:45 AM

| NO. | DATE | DESCRIPTION | BY | CKD. |
|-----------|---------|---------------------------|-----|------|
| 1 | 6-24-19 | REVISED DRAINAGE EASEMENT | GMT | RGC |
| REVISIONS | | | | |

ROBERT G. CAMPBELL & ASSOC., L.P.
 CONSULTING ENGINEERS
 KNOXVILLE, TENNESSEE

**ANDERSON COUNTY SOLID WASTE
 MARLOW CONVENIENCE CENTER**

**PLAN VIEW
 PROPOSED SITE LAYOUT**

| | | | |
|--------------------|-------------------|-------------------|----------------|
| DESIGNED BY GMT | CHECKED BY RGC | SCALE 1"=20' | SHEET NO. 3 |
| DRAWN BY GMT | DATE 9-17-20 | FILE NO. 19701 | OF TEN SHEETS |

DESIGN NOTES:

- 1) TWO (2) NEW CONCRETE COMPACTOR PADS TO BE INSTALLED WITH COLLECTOR DRAINS.
- 2) EXISTING CONCRETE TO BE OVERLAID WITH 4" LIFT. SEE DETAILS AND SPECIFICATIONS.
- 3) NEW CONCRETE DRIVE TO BE CONSTRUCTED AS SHOWN.
- 4) NEW 6" CONCRETE CURB TO BE INSTALLED ALONG LOWER END OF SITE.
- 5) EXISTING CATCH BASINS TO BE RAISED WITH NEW LIDS AND GRATES.
- 6) CONCRETE TRAFFIC-RATED SEPTIC TANK TO BE INSTALLED FOR STORAGE OF EFFLUENT FROM COMPACTOR DRAINS.
- 7) WATER QUALITY TREATMENT UNIT TO BE INSTALLED FOR TREATMENT OF STORMWATER RUNOFF.
- 8) TRAFFIC FLOW TO BE GENERALLY CLOCKWISE AS SHOWN. ENTRANCE TO BE WIDENED AS SHOWN.
- 9) WIDENING OF FORD ROAD TO BE CONDUCTED.

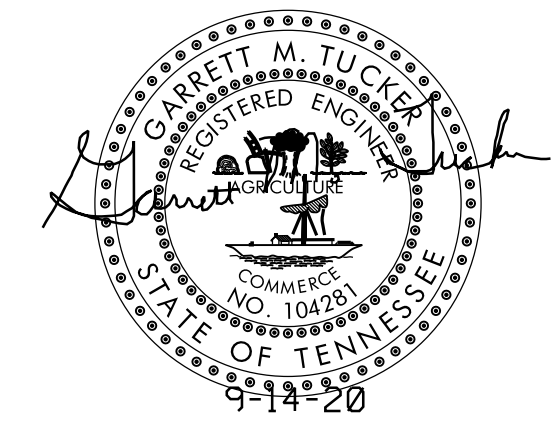

LEGEND

| | |
|--------|----------------------|
| ○ EIP | IRON PIN FOUND |
| PIPE | PIPE FOUND |
| □ G.V. | GAS VALVE |
| □ W.M. | WATER METER |
| ⊙ | MANHOLE |
| ⊥ | SIGN |
| □ W.V. | WATER VALVE |
| ⊗ | FIRE HYDRANT |
| ⊕ P/T | POWER/TELEPHONE |
| ○ | GUY WIRE |
| --- | GAS LINE (TYP) |
| --- | SANITARY SEWER (TYP) |
| --- | WATER LINE (TYP) |

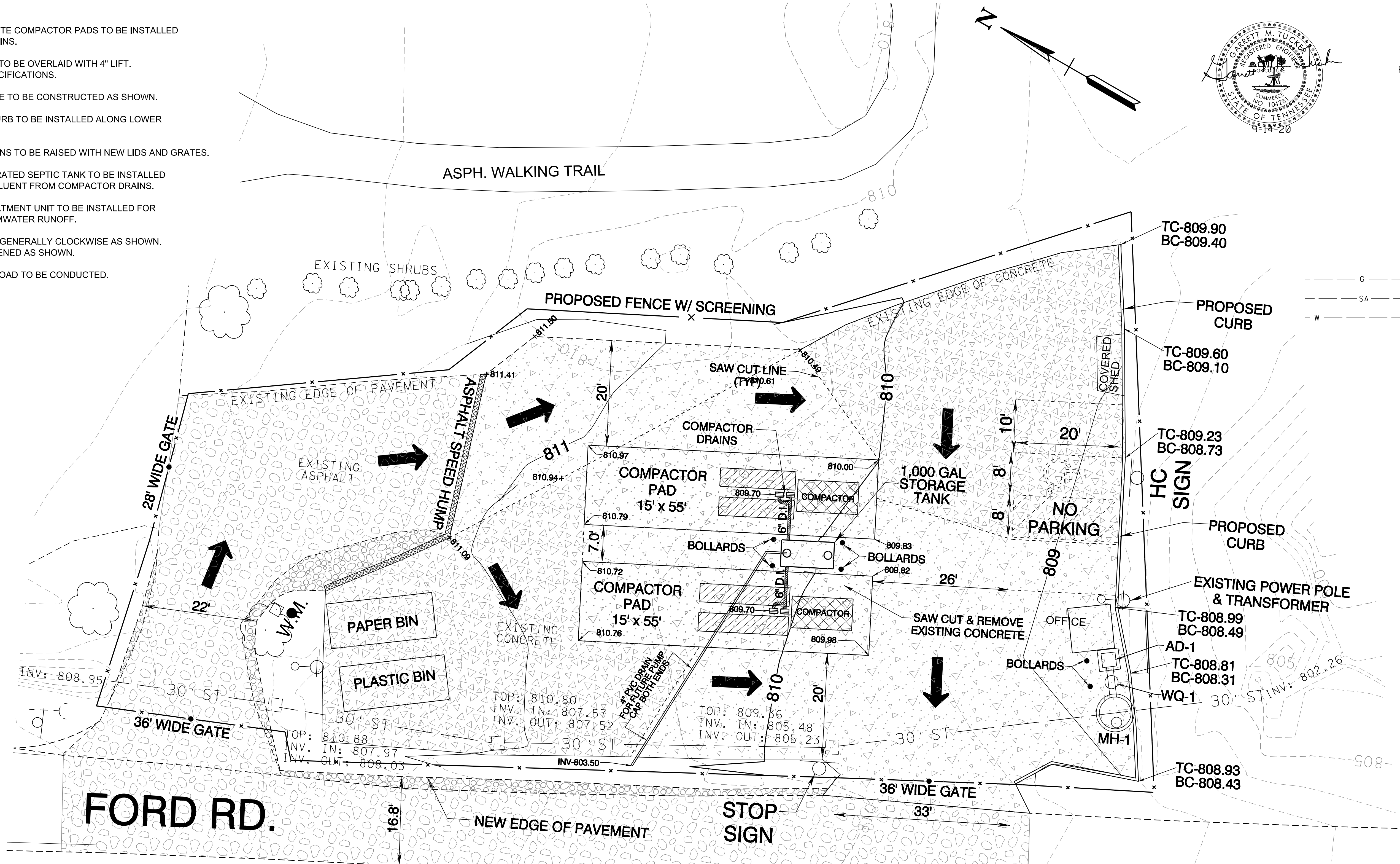

NOTES:

- 1) EXISTING MONUMENTS AS SHOWN. ALL OTHERS SET BY RGC&A.
- 2) EXISTING CONTOURS FROM TOPOGRAPHIC SURVEY. (NAVD 1988)
- 3) LOCATIONS OF UNDERGROUND UTILITIES SHOWN ARE APPROXIMATE. THERE MAY BE OTHER UTILITIES NOT SHOWN. PRIOR TO ANY EXCAVATION, THE OWNER AND/OR CONTRACTOR IS RESPONSIBLE FOR CONTACTING THE LOCAL UTILITY AUTHORITIES FOR EXACT LOCATIONS AND DEPTHS.
- 4) CONTRACTOR IS RESPONSIBLE FOR ALL TRENCH SAFETY PRACTICES.
- 5) EROSION CONTROL MEASURES SHOWN ON OTHER SHEETS ARE A MINIMUM. THE CONTRACTOR IS RESPONSIBLE FOR CONTROL OF EROSION ON SITE. ADDITIONAL ITEMS MAY BE REQUIRED.
- 6) a. APPLY TEMPORARY SEEDING WHENEVER GRADING OPERATIONS ARE TEMPORARILY HALTED FOR OVER 14 DAYS AND FINAL GRADING OF EXPOSED SURFACES IS TO BE COMPLETED WITHIN ONE YEAR. APPLY TEMPORARY SEEDING TO SOIL STOCKPILES.
b. APPLY PERMANENT SEEDING WHENEVER GRADING OPERATIONS ARE COMPLETED AND ALL CONSTRUCTION OPERATIONS WILL NOT IMPACT THE DISTURBED AREA. APPLY PERMANENT SEEDING TO ALL NON-CONSTRUCTION AREAS WHICH SHOW SIGNS OF EXCESSIVE EROSION.
- 7) THE CONTRACTOR SHALL HAVE A STAMPED AND SIGNED COPY OF THIS PLAN ON SITE AT ALL TIMES DURING CONSTRUCTION
- 8) NO SLOPES SHALL BE STEEPER THAN 2H:1V

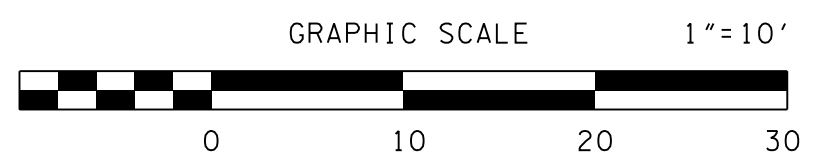

OWNER/DEVELOPER:
ANDERSON COUNTY, TENNESSEE
MAYOR TERRY FRANK
GEOFF TRABALKA
ANDERSON COUNTY SOLID WASTE COORDINATOR
100 NORTH MAIN STREET
ROOM 127
CLINTON, TN
(865) 463-6845

ENGINEER:
ROBERT G. CAMPBELL & ASSOC., L.P.
7523 TAGGART LANE
KNOXVILLE, TN, 37938
PHONE: 865-947-5996

CLT # 087
PARCEL 217.01

TOTAL AREA: 3.78 ACRES
DISTURBED AREA : 0.50 ACRES

DEED REFERENCE:
DB 1143 PG 235

L:\ANDERSON\1970\19701_Sheets.dgn 9/17/2020 11:54:22 AM

| NO. | DATE | DESCRIPTION | BY | CKD. |
|-----|---------|---------------------------|-----|------|
| 1 | 6-24-19 | REVISED DRAINAGE EASEMENT | GMT | RGC |

ROBERT G. CAMPBELL & ASSOC., L.P.
CONSULTING ENGINEERS
KNOXVILLE, TENNESSEE

ANDERSON COUNTY SOLID WASTE
MARLOW CONVENIENCE CENTER

PROPOSED SITE LAYOUT
SITE GRADING DETAIL

| | | | |
|--------------------|-------------------|-------------------|----------------|
| DESIGNED BY GMT | CHECKED BY RGC | SCALE 1"=10' | SHEET NO. 4 |
| DRAWN BY GMT | DATE 9-17-20 | FILE NO. 19701 | OF TEN SHEETS |

NOTE: TOP OF DRAIN TO BE A MINIMUM OF 2" LOWER THAN LOWEST OUTER PAD CORNER ELEVATION

ZURN Z668
11-1/4 x 19-1/4 [286 X 489] HEAVY-DUTY DRAIN
SPECIFICATION SHEET TAG _____

Dimensional Data (inches and [mm]) are Subject to Manufacturing Tolerances and Change Without Notice

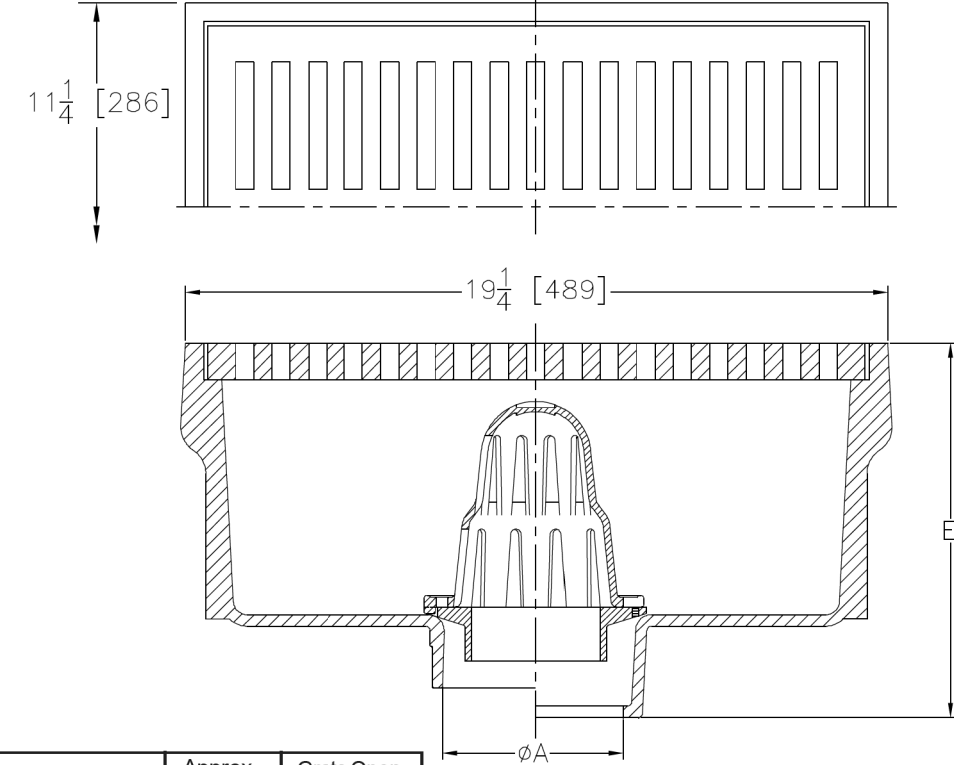

| A | Approx. Wt. Lbs. [kg] | Grate Open Area Sq. In. [cm ²] |
|---------------|-----------------------|--|
| 4.6 [102,152] | 115 [52] | 60 [387] |

ENGINEERING SPECIFICATION: ZURN Z668
11-1/4" X 19-1/4" [286mm x 489mm] Top drain, Dura-Coated cast iron body with bottom outlet, less seepage pan, with secondary strainer, loose heavy-duty slotted grate.

**COMPACTOR DRAIN DETAIL
ZURN 7668 OR EQUAL**

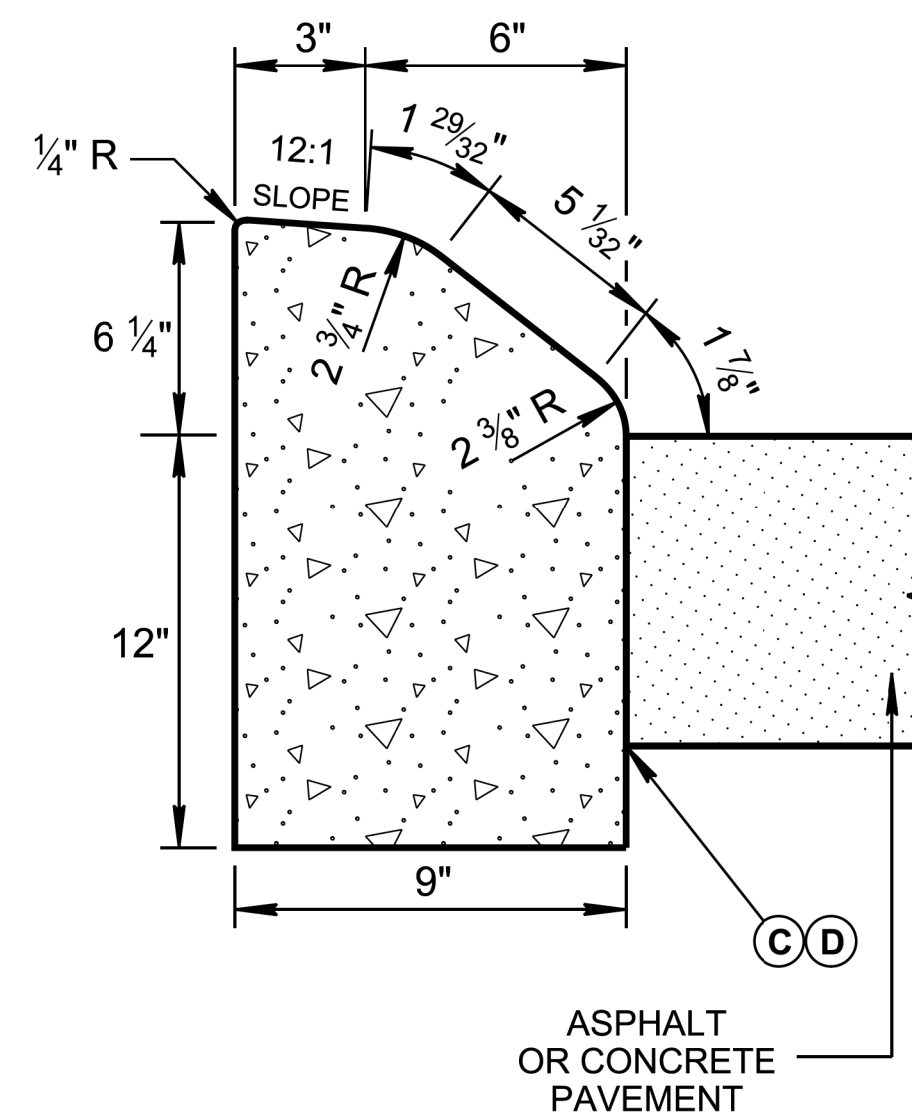

**6" SLOPING
DETACHED CONCRETE CURB**

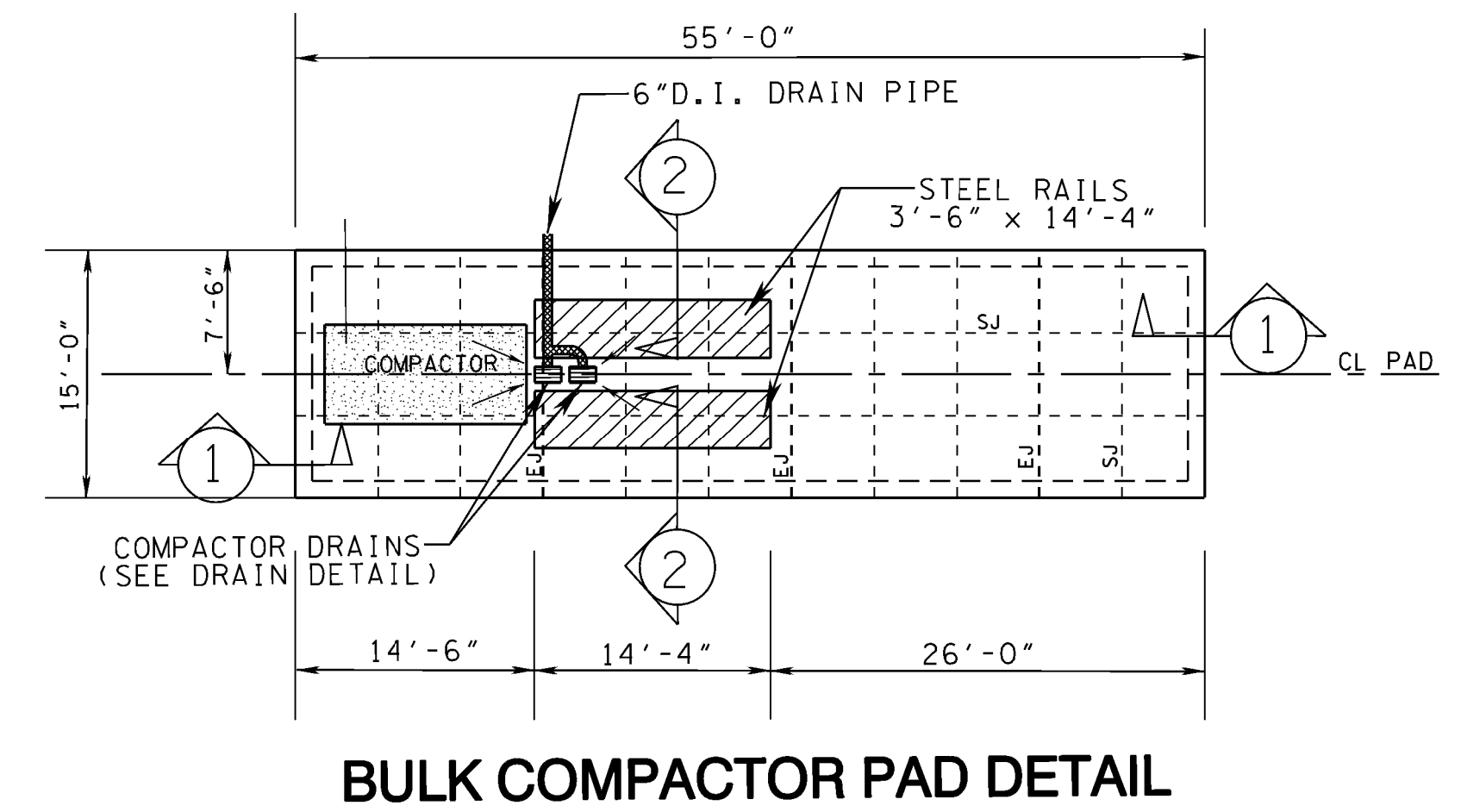

BULK COMPACTOR PAD DETAIL

Top View

End View

Side View

Specifications

Concrete: 5,000 psi minimum strength (28 day)

Reinforcing: Primary reinforcement will be top, side, and bottom #3 and/or #4 rebar (Grade 60) rebar.

Risers: Grade rings and manhole frames and covers sold separately.

Sealant: Sealant used in the seam of the tank will meet or exceed ASTM C990.

Pipe Penetrations: Inlet and outlets are fitted with seals that meet or exceed all ASTM C923 specifications.

Partition Wall: The partition wall, if present, is poured monolithically.

Installation: The tank hole is not to be more than one foot longer and wider than the tank. There shall be a minimum of 6" of stone bedding in soil terrain and a 12" stone bedding in rock terrain. Do not install across path of vehicles or heavy equipment. This tank is designed for one hundred fifty pounds per square foot (150 lb/ft²) uniform loading on the top of the tank with a maximum backfill cover of 36" and a minimum of 6".

Tank Warranty: The C. R. Barger & Sons, Inc. septic tank when installed in accordance with manufacturer's instructions is warranted against defective materials and/or workmanship for 1 year from the date of delivery to the project site. Should a defect appear within the warranty period, C. R. Barger & Sons, Inc. will supply a new septic tank in replacement thereof. C. R. Barger & Sons, Inc. liability is limited to the value of the septic tank itself and specifically excludes the cost of installation and/or removal and consequential damages. Failure to comply with C. R. Barger & Sons, Inc. installation procedures and general notes will void warranty.

npcA
CERTIFIED PLANT

Conduit penetration included with watertight boot.

| | | |
|---|---|---|
| Manufactured by: C. R. Barger & Sons, Inc. 123 Pawnee Farm Road Lenoir City, TN 37771 Phone 865.270.8080 Fax 865.270.8079 www.bargerandsons.com | General Notes: All vertical measurements are accurate within ± 1 inch on the tank. The lids can be moved and resized if necessary. | Tank Type: Decontamination Tank 1000 Gallon Date: 3.25.2006 Approx. Weight: 13,000 lbs. Drawn By: Eric Barger |
|---|---|---|

**1,000 GALLON STORAGE TANK
TYPICAL DETAIL
BARGER & SONS OR EQUAL**

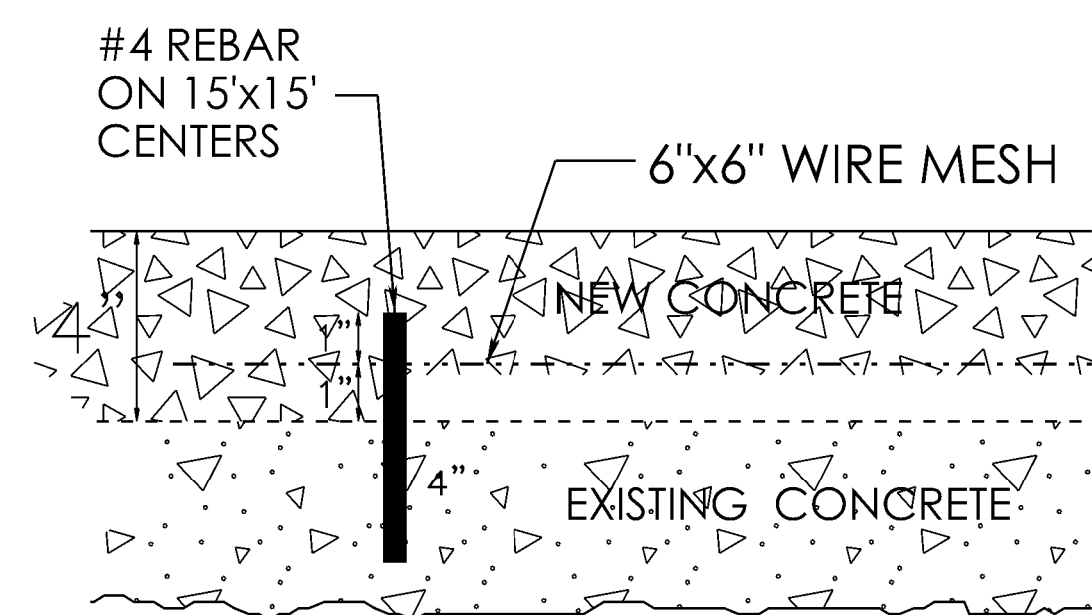

DOWEL ROD ANCHOR DETAIL

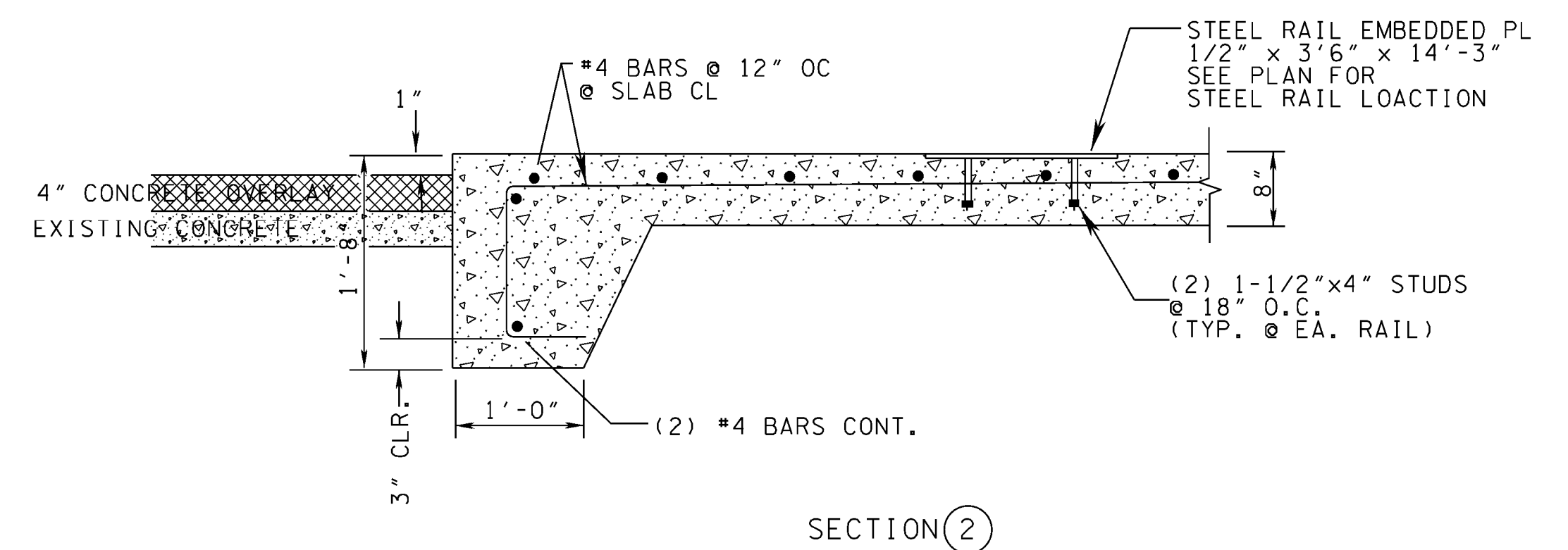

SECTION 2

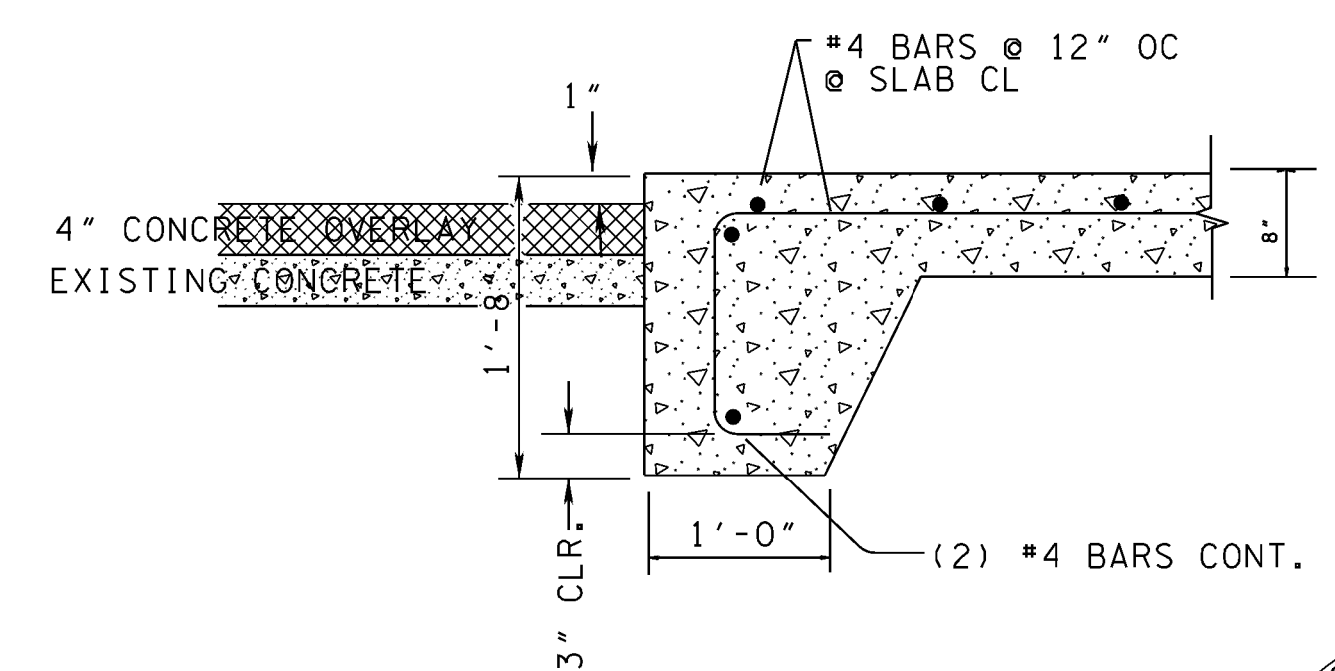

SECTION 1

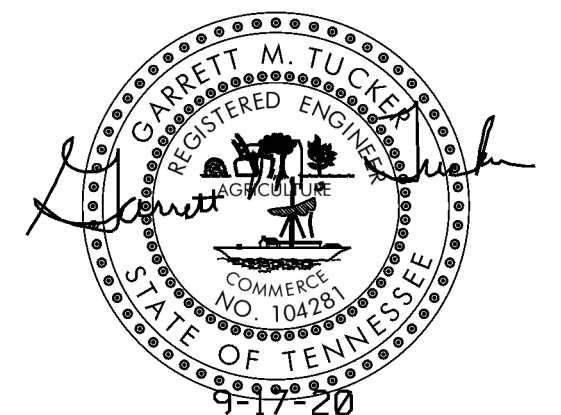

| NO. | DATE | DESCRIPTION | BY | CKD. |
|-----------|------|-------------|----|------|
| REVISIONS | | | | |



ROBERT G. CAMPBELL & ASSOC., L.P.
CONSULTING ENGINEERS
KNOXVILLE, TENNESSEE

**ANDERSON COUNTY SOLID WASTE
MARLOW CONVENIENCE CENTER**

DETAILS

| DESIGNED BY | CHECKED BY | SCALE | SHEET |
|-------------|------------|----------|---------------|
| GMT | RGC | NO SCALE | NO. 7 |
| DRAWN BY | DATE | FILE NO. | OF TEN SHEETS |
| GMT | 9-17-20 | 19701 | |