



FORT HAYS STATE UNIVERSITY

Addendum

Date: February 21, 2024

RFP Number: 24019

Addendum: 1

Closing Date: Thursday, February 29, 2024, by 4:30 p.m.

Fort Hays State University Purchasing Office

Telephone: 785-628-4251

Fax: 785-628-4046

E-Mail Address: purchasing@fhsu.edu

Web Address: <http://www.fhsu.edu/purchasing/bids>

Item: Floor Covering Materials and Labor for Albertson and Stroup Halls

Agency: Fort Hays State University (FHSU), Hays, KS

Conditions:

See drawings attached for the flooring pattern for Stroup Hall.

A signed copy of this Addendum must be submitted with your bid. If your bid response has been returned, submit this Addendum by the closing date indicated above.

I (We) have read and understand this addendum and agree it is a part of my (our) bid response.

NAME OF COMPANY OR FIRM: _____

SIGNED BY: _____

TITLE: _____ DATE: _____

Fort Hays State University - Summer 2024

1st Floor Estimate 2
02.20.24

Interface®

AE310

104623 Taupe
50 x 50 cm | 774 tiles | 231.42 yd²

AE313

104881 Taupe/Flannel
25 x 100 cm | 757 tiles | 226.34 yd²

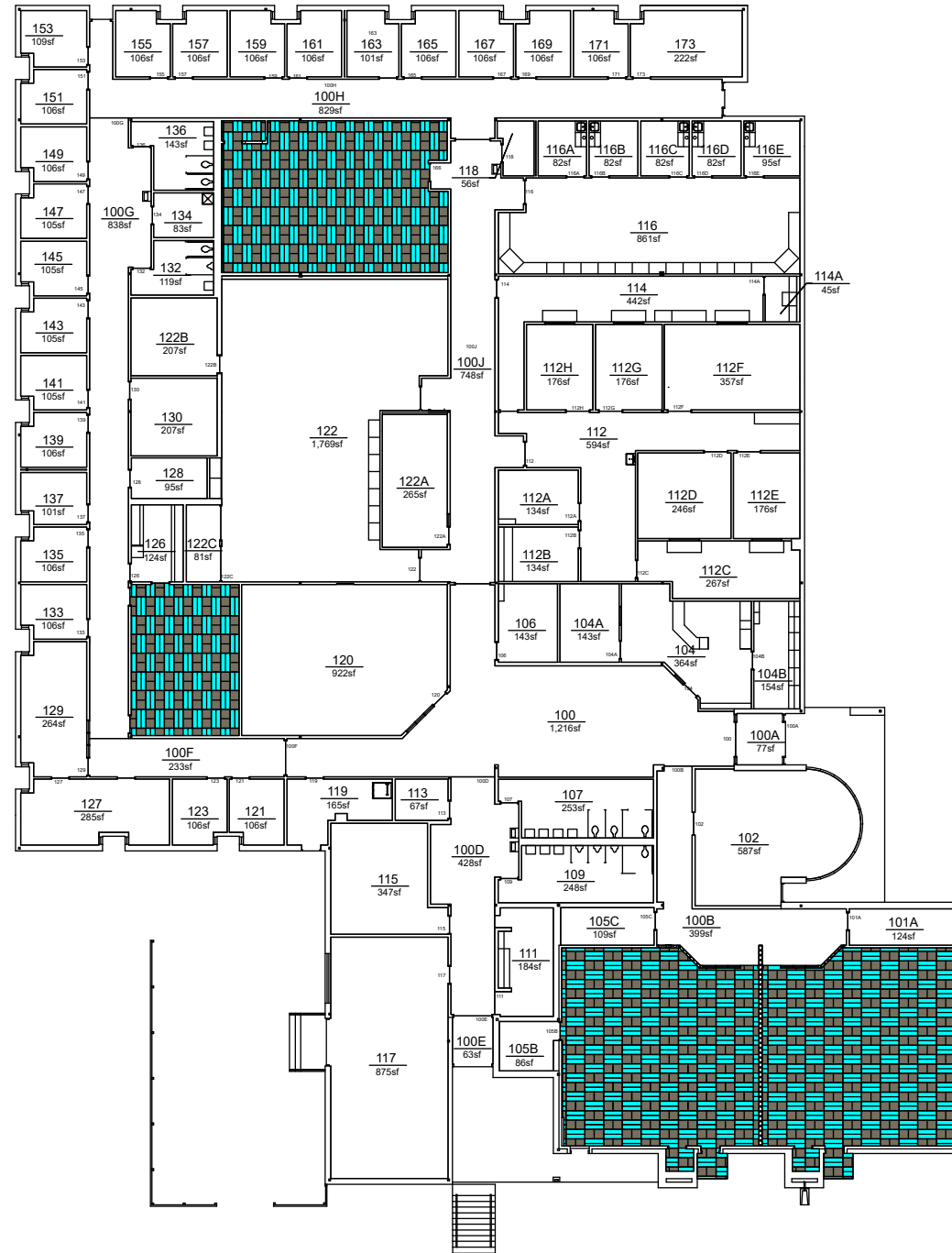

DESIGN STUDIO

Not To Scale
Case 00845330

© 2020 Interface, Inc and nora systems GmbH. For reference only. Measurements not to scale and not guaranteed to meet project specifications. Not for reliance on ordering materials or products. See interface.com/IDSdisclaimer for full disclaimer limitations. For the best results please view this PDF on screen only, as printing may compromise the colour and clarity of the images.

 **Carbon Neutral Floors™**
Learn more about our third-party verified Carbon Neutral Floors.
www.interface.com/carbonneutral

Fort Hays State University - Summer 2024

1st Floor Rendered Plan 2
02.20.24

Interface®

Aerial Collection - AE310
104623 Taupe
50 x 50 cm
Installed Pattern By Tile

Aerial Collection - AE313
104881 Taupe/Flannel
25 x 100 cm
Installed Pattern by Tile

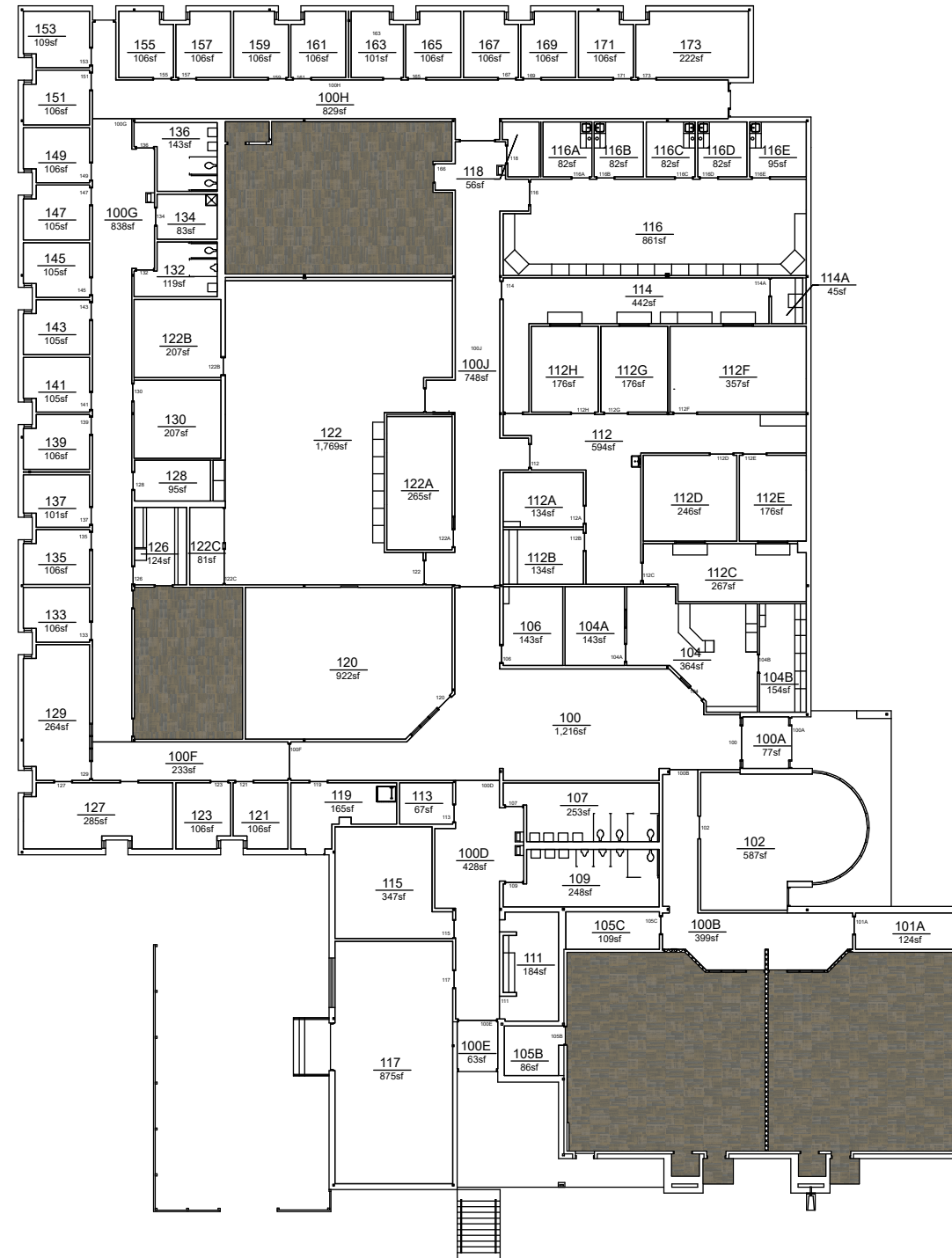

DESIGN STUDIO

Not To Scale
Case 00845330

© 2020 Interface, Inc and nora systems GmbH. For reference only. Measurements not to scale and not guaranteed to meet project specifications. Not for reliance on ordering materials or products. See interface.com/IDSdisclaimer for full disclaimer limitations. For the best results please view this PDF on screen only, as printing may compromise the colour and clarity of the images.

 **Carbon Neutral Floors™**
Learn more about our third-party verified Carbon Neutral Floors.
www.interface.com/carbonneutral



FORT HAYS STATE UNIVERSITY

Forward thinking. World ready.

REQUEST FOR QUOTE #24019

Date Posted: February 15, 2023

Question Deadline: February 21, 2024, 12 p.m.

Closing Date: Thursday, February 29, 2024, 4:30 p.m.

RETURNED SIGNED QUOTE TO:

Fort Hays State University (FHSU)

Purchasing Office

601 Park Street Sheridan Hall Room 318

Hays, KS 67601

It shall be the bidder's responsibility to monitor this website on a regular basis for any changes/addenda, <http://www.fhsu.edu/purchasing/bids>.

Purchasing Office Contact Information:

Telephone: 785-628-4251

Fax: 785-628-4046

Email: purchasing@fhsu.edu

INSTRUCTIONS TO BIDDERS:

1. The FHSU Purchasing Office is the only point of contact for this RFQ. When communicating, always refer to the quotation number.
2. To be considered, one copy of this quotation, with your bid properly filled in, must be signed and returned to the FHSU Purchasing Office by the specified closing date. E-mail and late bids cannot be considered.
3. **Submit bid response through FHSU's bid solicitation site, Vendor Registry:** <https://fhsu.edu/purchasing/bids/index.html>.
4. Bid must be in U.S. Dollars (\$US) excluding Federal Excise/State Sales Taxes.
5. All prices and conditions must be shown. Additions or conditions not shown on this bid will not be allowed.
6. Bid for comparable merchandise will be considered, unless the specifications indicate "no substitution".
7. Bidder must specify exceptions to any requirement or specification in the bid.
8. Bid must include complete specifications and/or descriptive literature to facilitate consideration.
9. Please browse our web-site for similar pending requests.
10. **THIS IS NOT AN ORDER.**

FHSU seeks bids for floor covering materials and labor for Albertson and Stroup Halls as specified below.

All questions must be submitted to the Purchasing Office in writing to purchasing@fhsu.edu by 12 p.m. on Wednesday, February 21, 2024.

NOTE: Vendors must register through Vendor Registry to access this bid document on FHSU Purchasing website, <https://fhsu.edu/purchasing/bids/index.html>. Submit your bid response through Vendor Registry.

Complete information and pricing, Cost Sheets, on pages 1 and 7 – 10, and provide the Grand Total Delivered Price (FOB Destination Prepaid & Allowed)

\$ _____

TO BE CONSIDERED, THE FOLLOWING INFORMATION MUST BE PROVIDED BY THE BIDDER:

DATE _____

TERMS _____

DELIVERY WILL BE MADE _____ DAYS A.R.O.

F.O.B. DEST. Fort Hays State University, Hays, KS 67601

F.E.I.N. OR S.S.N. _____

NAME _____

ADDRESS _____

CITY _____ ST _____ ZIP _____

SIGNED BY _____

PRINT OR TYPE NAME _____

TITLE _____

TELEPHONE # _____

FAX # _____

E-MAIL ADDRESS _____

CHECK IF APPLICABLE

Small Business _____ Woman-Owned _____ Minority-Owned _____

Specifications

FY25 Summer 2024 Flooring Replacement

SUMMARY OF THE WORK

PART 1 - GENERAL

1.1 SUMMARY

- A. This section applies to all areas identified in the contract documents as to receive the following types of floor coverings:
 - 1. Carpet Tile
 - 2. Thin-Set Porcelain Tile
- B. Removal of existing carpet and rubber base are included in this project as per drawings unless otherwise noted.
- C. Contractor will prepare the floor as required for installation.
- D. Contractor shall be **required** to visit all areas of work to verify existing room conditions, dimensions, and cabinet locations prior to submitting this bid.
- E. Fort Hays State University reserves the right to award purchases by carpet/tile type, manufacturer, or project, whichever is deemed to be in the university's best interest.
 - 1. Awards will not be made by individual rooms. Show pricing as identified on bid sheet.

1.2 JOB CONDITIONS

- A. Occupancy: Owner will be continuously occupying areas of the building immediately adjacent to areas of selective demolition. Conduct selective demolition work in a manner that will minimize the need for disruption of Owner's normal operations. Provide minimum of 72 hours advance notice to Owner of demolition activities which will severely impact Owner's normal operations.
- B. Hazardous Materials: The Owner, due to ownership of the existing buildings, holds legal title to hazardous materials if included therein. It is the Owner's responsibility to determine whether hazardous materials exist, and to legally dispose of such materials if they are discovered.
- C. Owner agrees to indemnify and hold harmless the contractor against hazardous material claims. If the Contractor encounters hazardous materials which have not been rendered harmless, the Contractor shall immediately stop work in the area affected and report the condition to the Owner in writing. Work in the affected area shall not be resumed except by written agreement of the Owner and Contractor.
- D. It is recommended that if hazardous materials are encountered, or if they are believed to exist, the Owner should seek the services of a qualified and competent hazardous waste consultant.

1.3 CONTRACTOR ASSURANCES

- A. Contractor must have equipment available normally used in work commonly associated with the trade.
 - 1. Furnish all equipment necessary to carry out performance requirements.
 - 2. No charges will be allowed for tools.
- B. Contractor shall be responsible for and pay for.
 - 1. All damages to buildings, walks, pavements, steps, plantings, lawns, and any other property incurred during removal of existing and installation of new, including interior walls.

2. Such damage shall be corrected by repair or replacement as directed by owner at contractor's expense.
3. If installation or materials is defective the owner must grant permission to repair any defective installation or material. If permission is not granted the installation or material must be removed and replaced at the contractor's expense. Permission to repair any such installation or material shall not constitute a waiver of the owner's right to require complete removal of defective installation if the repair attempt does not restore quality and appearance of the defective part to owner's satisfaction. If permission is granted, the repair must be done according to the owner's direction.

1.4 SUBMITTALS

- A. Contractors shall see attached plan sheets for a complete list of flooring products. Plan sheets and finish schedule notes contain a complete list of finishes.
- B. Provide data on specified products, describing physical performance characteristics, sizes, patterns, colors available, and method of installation for owner approval.
- C. Where only a single product or manufacturer is named, provide the product indicated. No substitutions will be permitted.

1.5 WARRANTY

- A. Product and Installation warranty
 1. Install the carpet using manufacturer-approved products and procedures as to not void any standard Warranties for each type of carpet installed.

1.6 EXTRA MATERIALS

- A. Furnish extra materials that match and are from the same production runs as products installed and that are packaged with protective covering for storage and identified with labels describing contents.
 1. Carpet, Tile and Resilient Flooring: Furnish quality of full-size units equal to **2 percent** of amount installed for each type, composition, color, pattern, and size indicated.
 2. Trim Units: Furnish all open cartons of trims and base.
 3. Grout: Furnish quality of grout equal to **2 percent** of amount installed for each type, composition, and color indicated.

1.7 INSURANCE AND LIABILITY

- A. Any personal liability to contractor arising from this agreement shall be covered by applicable insurance to the extent required; no interpretation shall be allowed to find the State of Kansas or its agencies responsible for loss or damage to personnel or property nor to hold contractors harmless from any such occurrences. Contractor shall possess Workmen Compensation Insurance in the amount required by law.

1.8 DISPOSAL OF DEMOLISHED MATERIALS

- A. Disposal:
 1. Transport demolished materials off property and legally dispose of them.
 2. Contractor's options to bring in roll-off dumpster. Verify of location for dumpster with Owner. Existing dumpsters are for campus use only.

1.9 SITE CONDITIONS

A. Access, Parking, Storage and Site:

1. The prospective Bidder shall familiarize himself with the traffic regulations and parking storage areas he will become involved with if he becomes the Contractor. The Contractor shall inform his workmen of these regulations and conditions.
2. Parking and storage areas shall be as designated by the Owner.
3. FHSU is a non-smoking campus. Use of tobacco or vaping products is not permitted on site.

PART 2 - PRODUCTS**2.1 CARPET**

A. Provide and install selected carpets for each area identified within the attached drawings.

1. **Carpet Type 1:** Mohawk
 - a. Style: First One Up II (BT443)
 - b. Color: Immediate (869)
 - c. Size: 24" x 24"
 - d. Backing: EcoFlex ICT
2. **Carpet Type 2:** Interface
 - a. Style: AE313
 - b. Color: Taupe Flannel (104881)
 - c. Size: 9.845" x 39.38"
 - d. Backing: GlasBac Tile
3. **Carpet Type 3:** Interface
 - a. Style: AE310
 - b. Color: Taupe (104623)
 - c. Size: 19.69" x 19.69"
 - d. Backing: GlasBac Tile
4. **Carpet Type 4:** Interface
 - a. Style: Viva Colores
 - b. Color: Café Tostado (106046)
 - c. Size: 19.69" x 19.69"
 - d. Backing: GlasBac Tile

2.2 PORCELAIN TILE

A. Provide and install selected tile for each area identified within the attached drawings.

1. **Porcelain Tile Type 1:** Daltile
 - a. Style: Keystones
 - b. Color: Golden Granite (D138)
 - c. Size: 2 in x 2 in.
 - d. Finish: Matte
 - e. Thickness 1/4"

2.3 OTHER MATERIALS

A. Provide 4" vinyl cove, color(s) as specified. Install in longest practical lengths with adhesive in accordance with manufacturer's recommendations.

1. Rubber Base (RB1):
 - a. Johnsonite
 - b. Height: 4 in
 - c. Thickness: 00.125" Gauge
 - d. Style: Standard, Toe Base
 - e. Color: Burnt Umber 63
 - f. Length: Continuous 120-foot roll

2. Provide Polymer-Modified Tile Grout.
 - a. TEC AccuColor Plus Grout or approved equal.
 - b. Color: best match to existing quarry tile areas.
- B. Provide Adhesive 2000 plus, which is specially designed to install Interface GlasBac carpet tiles.
- C. Provide EnPress PSA Pressure Sensitive Adhesive is specially designed to install Mohawk Group EcoFlex carpet tiles.
- D. Provide solid color transitions or reducers, color(s) as selected. Install in longest practical lengths with adhesive in accordance with manufacturer's recommendations.
- E. Provide sealants, primers, backer rods, and other sealant accessories. Provide colors of exposed sealants to match colors of grout in tile adjoining sealed joints unless otherwise indicated.
- F. Trowel-able Underlayment and Patching Compounds: Latex-modified, Portland cement-based formulation provided or approved by manufacturer of tile-setting materials for installations indicated.
- G. Grout Sealer: Manufacturer's standard silicone product for sealing grout joints and that does not change color or appearance of grout.
- H. Provide other materials, not specifically described but required for a complete and proper installation, as selected by the Contractor subject to the approval of Owner.

PART 3 - EXECUTION

3.1 INSTALLATION

- A. Clean and make substrata level and free from irregularities. All major irregularities will be addressed by owner prior to installation.
- B. Prepare surfaces using the methods recommend by the manufacturer for achieving the best result for the substrate under the project conditions.
- C. Install carpet tile and porcelain tile per manufacturer instructions.
- D. Protect installed products until completion of project.
- E. Owner must preform a final inspection before final completion.

END OF FLOOR FINISHES

FY25 SUMMER 2024 FLOORING REPLACEMENT

Vendor: _____

Prepared by: _____

Contact Information: _____

E-mail (if available): _____

State Credit Card: Presently, FHSU uses a State of Kansas Procurement Card (Visa) in lieu of a state warrant to pay for some of its purchases. No additional charges will be allowed for using the card. Will the credit card be allowed for purchases? Yes _____ No _____ (Refusal will not be a determining factor in the award.)

**SUMMER 2024 FLOORING REPLACEMENT
COST PROPOSAL
COST SHEET AND TENTATIVE SCHEDULE**

**SUMMER BREAK
May 20th – JULY 26th**

PROJECT #1

ALBERTSON HALL OFFICES

Albertson Hall: 3rd Floor Offices 302, 302A, 302B, 311, 313, 315, 317, 319, 322, 324 and 326

Carpet Type #1:

Carpet: Mohawk "First One Up II", Color "Immediate" (869)

RB1 / Transition: 4" Johnsonite Burnt Umber #63

Installation: Ashlar

Materials: \$ _____

Labor: \$ _____

Project Total: \$ _____

**SUMMER 2024 FLOORING REPLACEMENT
COST PROPOSAL
COST SHEET AND TENTATIVE SCHEDULE**

SUMMER BREAK
May 20th – JULY 26th

PROJECT #2

STROUP HALL OFFICES AND CLASSROOMS

Stroup Hall Classrooms: 101 and 105

Carpet Type #2 and #3:

Carpet: Interface “AE313”, Color “Taupe / Flannel” (104881)

Installation: Reference attached pattern layout

“AE310”, Color "Taupe" (104623)

Installation: Reference attached pattern layout RB3 /

Transition: 4” Johnsonite Burnt Umber #63

Porcelin Tile Type #1:

Tile: Daltile “Keystones”, Color “Golden Granite” (D138) Grout:

Match existing grout to surrounding quarry tile.

Stroup Hall Classrooms: 124 and 166

Carpet Type #2 and #3:

Carpet: Interface “AE313”, Color “Taupe / Flannel” (104881)

Installation: Random Ashlar “AE310”,

Color "Taupe" (104623)

Installation: Random Ashlar

RB3 / Transition: 4” Johnsonite Burnt Umber #63

Materials: \$ _____

Labor: \$ _____

Project Total: \$ _____

**PROPOSAL
COST SHEET AND TENTATIVE SCHEDULE**

**SUMMER BREAK
May 20th – JULY 26th**

PROJECT #3

STROUP HALL OFFICES

**Stroup Hall Offices: 121, 123, 127, 129, 133, 135, 137, 139, 141, 143, 145, 147, 149, 151, 153, 155,
157, 159, 161, 163, 165, 167, 169, 171 and 173**

Carpet Type #6 and #7

Carpet: Interface "Viva Colores", Color "Café Tostado" (106046)

Installation: Quarter Turn

RB3 / Transition: 4" Johnsonite Burnt Umber #63

Materials: \$ _____

Labor: \$ _____

Project Total: \$ _____

INSTALL DATES:
 SUMMER 2024
 TENTATIVE: MAY 20TH - JULY 26TH

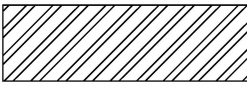

CPT 1: MOHAWK: "FIRST ONE UP II" - IMMEDIATE
 (869) BASE/TRANSITION:
 RB 1: JOHNSONITE: 63 BURNT UMBER

PROVIDE AND INSTALL BASE AS SHOWN.

PROVIDE AND INSTALL NEW
 TRANSITIONS AS NEEDED

DIMENSIONS ON DRAWINGS ARE FOR
 REFERENCE ONLY, IT IS THE CONTRACTORS
 RESPONSIBILITY TO VERIFY ALL CONDITIONS.

IT WILL BE THE INSTALLER RESPONSIBILITY
 TO DISPOSE OF EXISTING CARPET
 FROM CAMPUS AS PART OF THE BID.

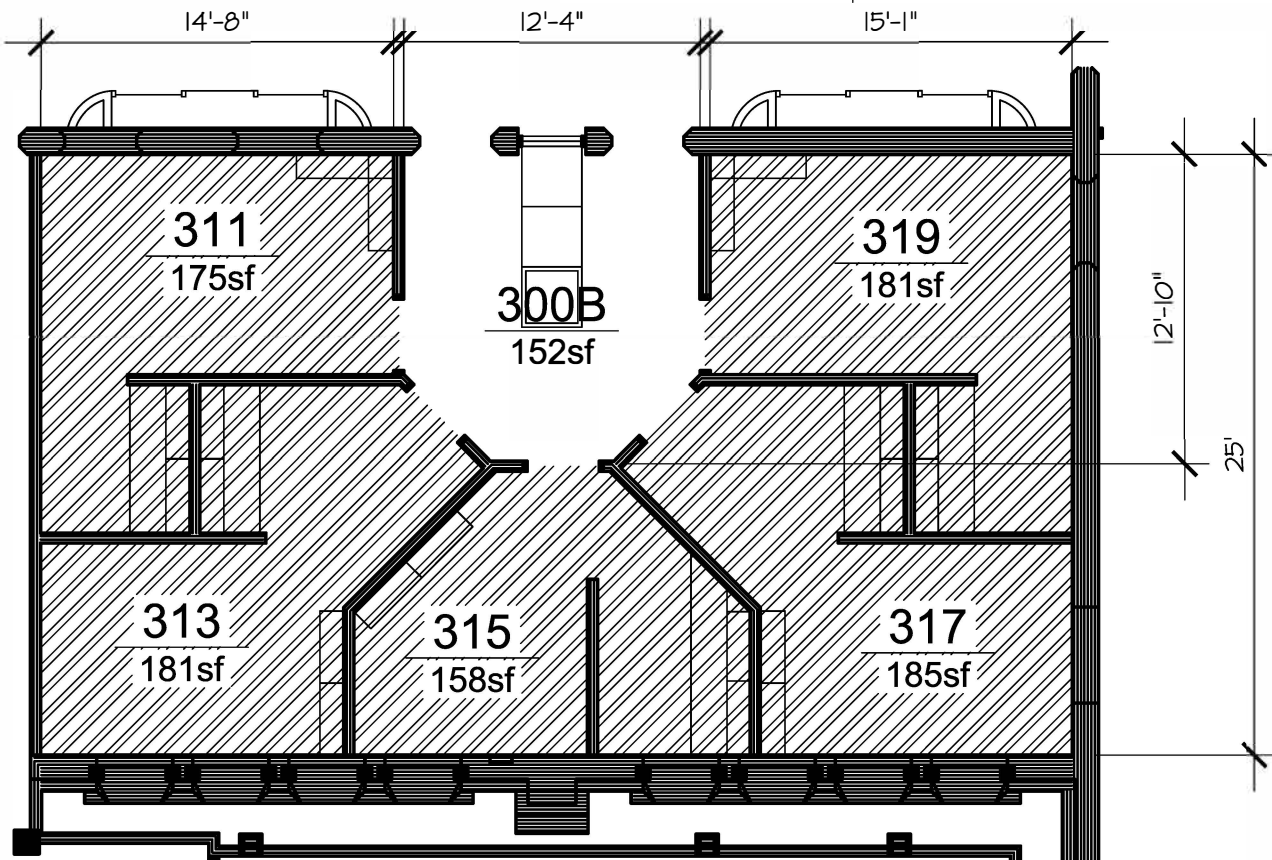
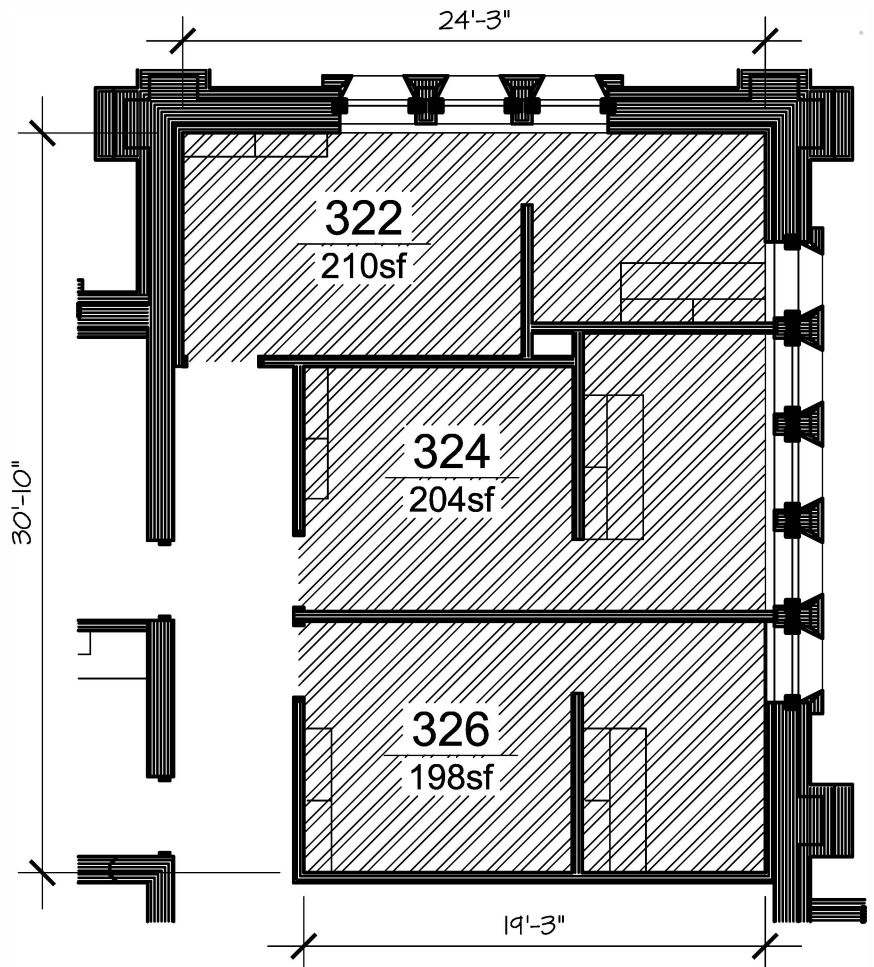

ALBERTSON HALL - THIRD FLOOR PLAN

SCALE: 1/8" = 1'

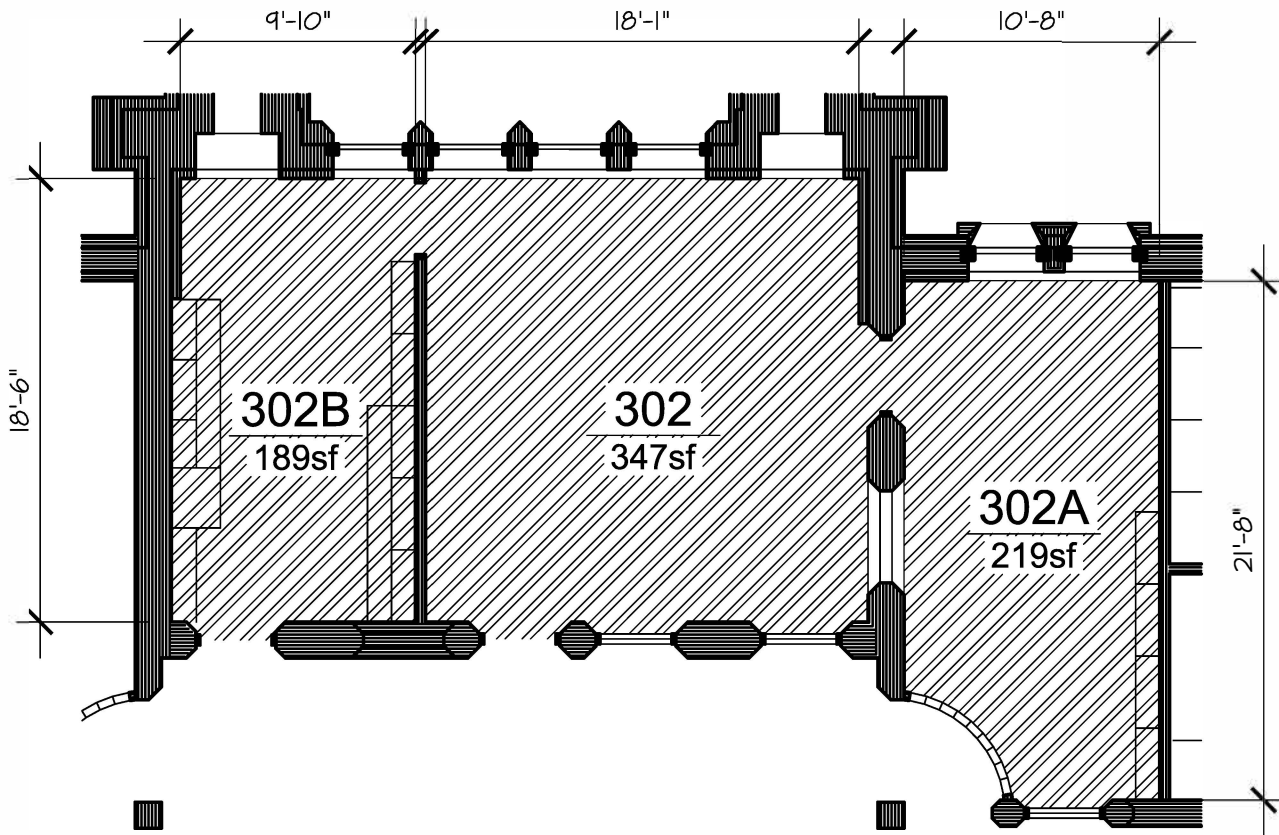
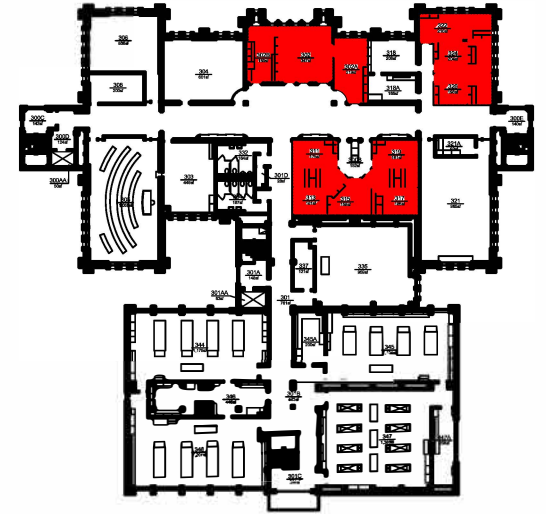

INSTALL DATES:
 SUMMER 2024
 TENTATIVE: MAY 20TH - JULY 26TH

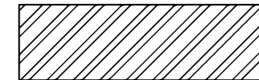

CPT 1: MOHAWK: "FIRST ONE UP II" - IMMEDIATE (869)

BASE/TRANSITION:
 RB 1: JOHNSONITE: 63 BURNT UMBER

PROVIDE AND INSTALL BASE AS SHOWN.

PROVIDE AND INSTALL NEW
 TRANSITIONS AS NEEDED

DIMENSIONS ON DRAWINGS ARE FOR
 REFERENCE ONLY, IT IS THE CONTRACTORS
 RESPONSIBILITY TO VERIFY ALL CONDITIONS.

IT WILL BE THE INSTALLER RESPONSIBILITY
 TO DISPOSE OF EXISTING CARPET
 FROM CAMPUS AS PART OF THE BID.

ALBERTSON HALL - THIRD FLOOR PLAN

SCALE: 1/8" = 1'

INSTALL DATES:
SUMMER 2024
TENTATIVE: MAY 20TH - JULY 26TH

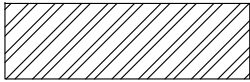

CPT 2: INTERFACE: AE313
TAUPE / FLANNEL (104881)
CPT 3: INTERFACE: AE310
TAUPE (104623)

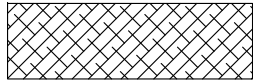

PT 1: DALTILE: KEYSTONES
GOLDEN GRANITE (D138)
BASE/TRANSITION:
RB 1: JOHNSONITE: 63 BURNT UMBER

PROVIDE AND INSTALL BASE AS SHOWN.

PROVIDE AND INSTALL NEW
TRANSITIONS AS NEEDED

DIMENSIONS ON DRAWINGS ARE FOR
REFERENCE ONLY, IT IS THE CONTRACTORS
RESPONSIBILITY TO VERIFY ALL CONDITIONS.

IT WILL BE THE INSTALLER RESPONSIBILITY
TO DISPOSE OF EXISTING CARPET
FROM CAMPUS AS PART OF THE BID.

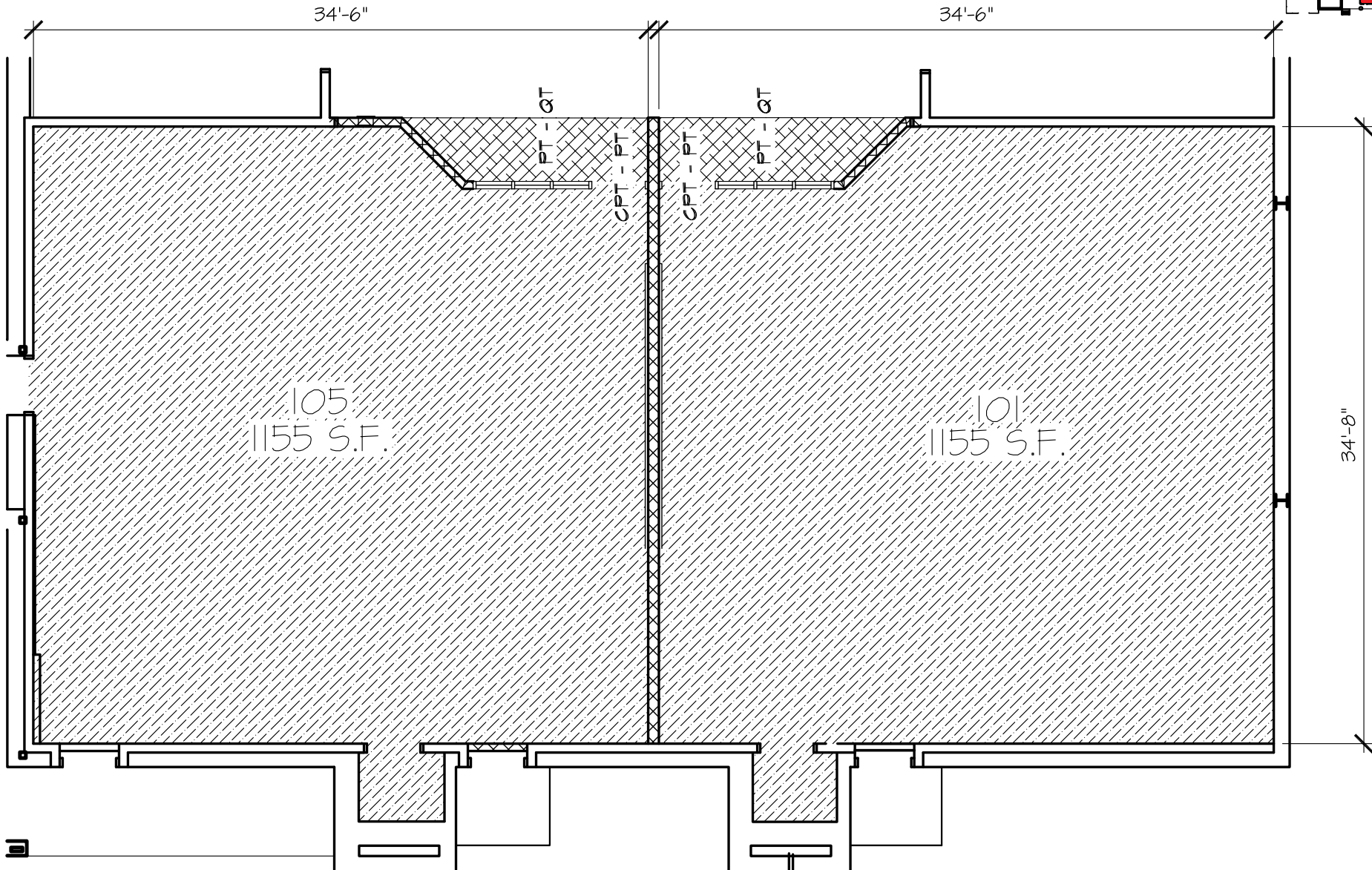
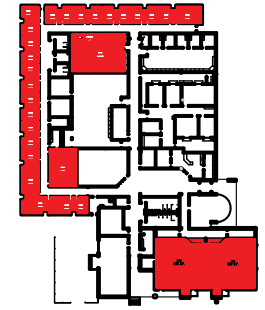

STROUP HALL - FIRST FLOOR PLAN

SCALE: 1/8" = 1'

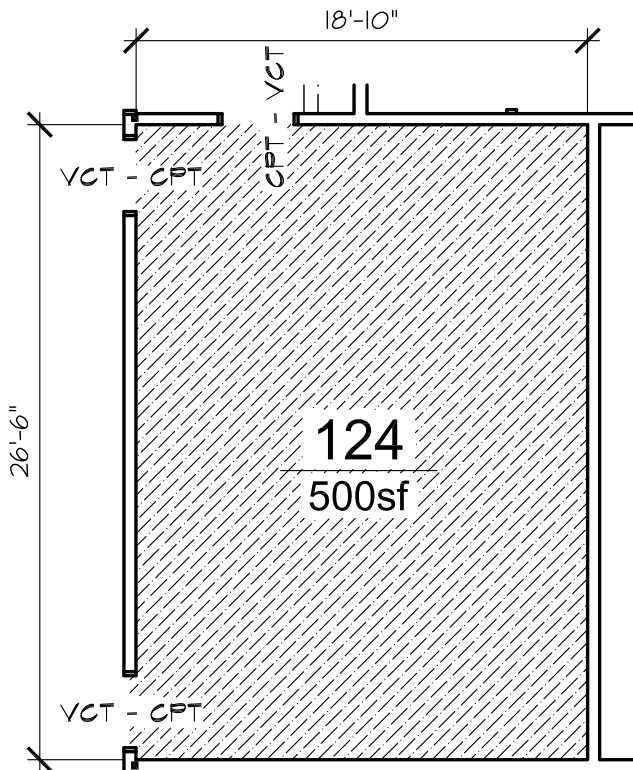
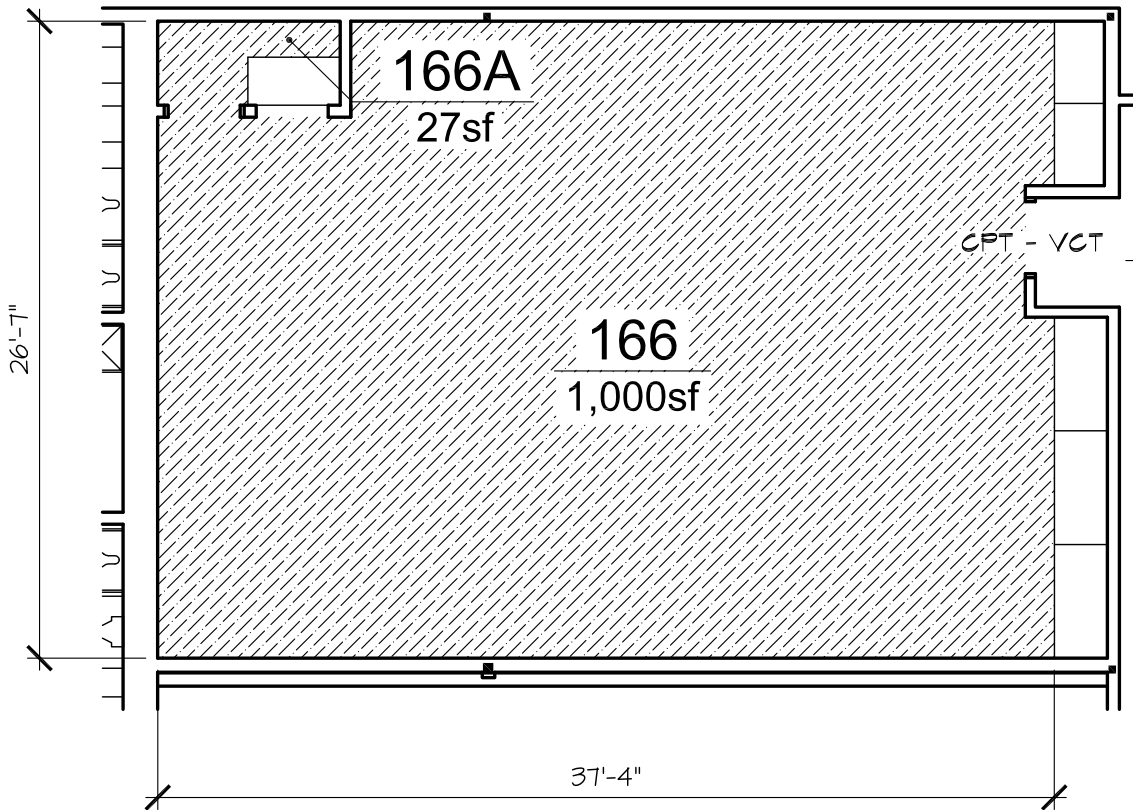

INSTALL DATES:
 SUMMER 2024
 TENTATIVE: MAY 20TH - JULY 26TH



CPT 2: INTERFACE: AE313
 TAUPE / FLANNEL (104881)

CPT 3: INTERFACE: AE310
 TAUPE (104623)

BASE/TRANSITION:
 RBI: JOHNSONITE: 63 BURNT UMBER

PROVIDE AND INSTALL BASE AS SHOWN.

PROVIDE AND INSTALL NEW
 TRANSITIONS AS NEEDED

DIMENSIONS ON DRAWINGS ARE FOR
 REFERENCE ONLY, IT IS THE CONTRACTORS
 RESPONSIBILITY TO VERIFY ALL CONDITIONS.

IT WILL BE THE INSTALLER RESPONSIBILITY
 TO DISPOSE OF EXISTING CARPET
 FROM CAMPUS AS PART OF THE BID.

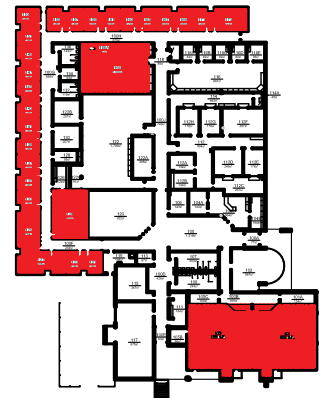

STROUP HALL - FIRST FLOOR PLAN

SCALE: 1/8" = 1'

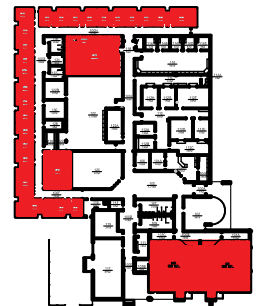
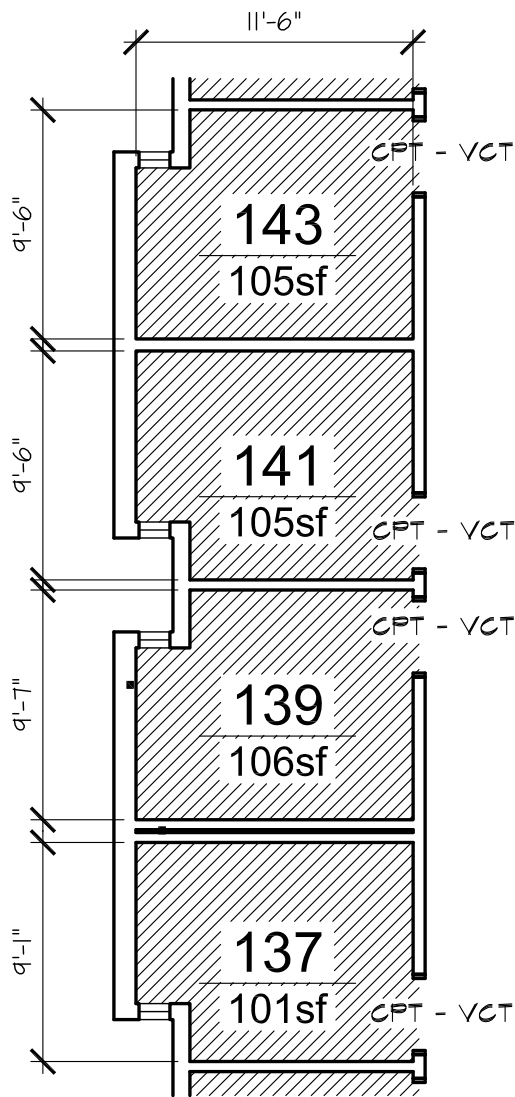
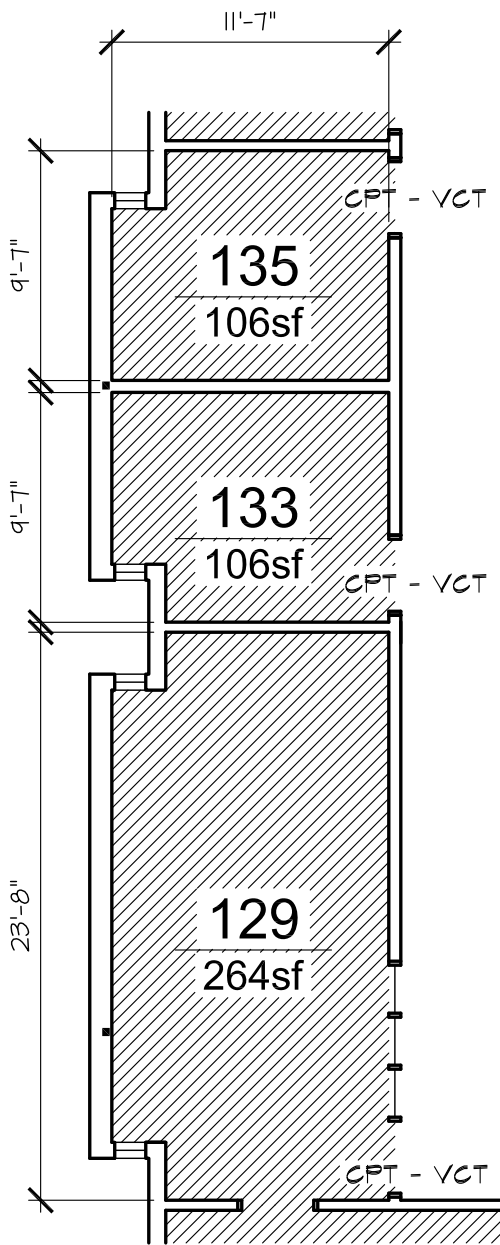
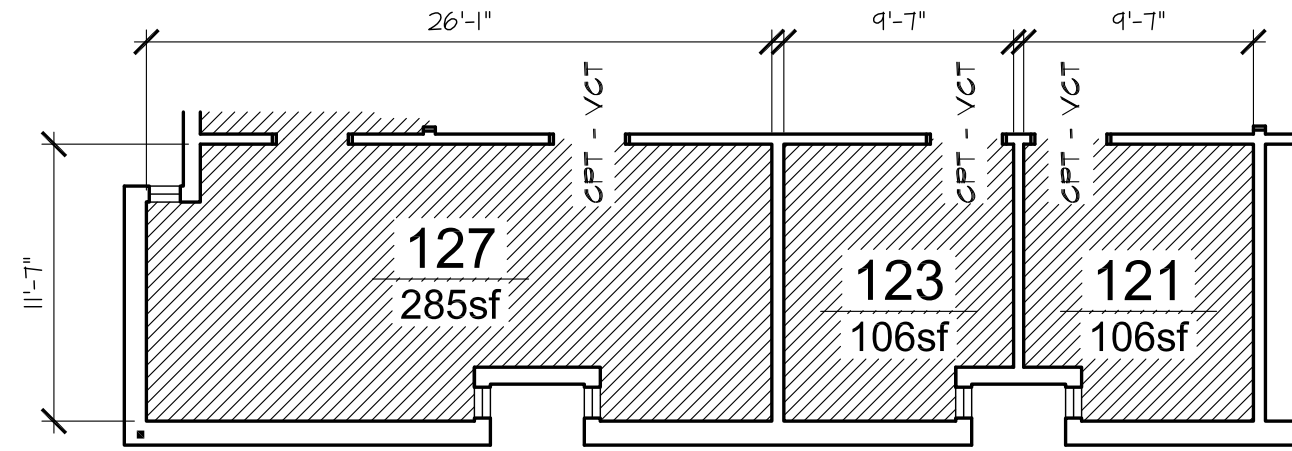

PROVIDE AND INSTALL BASE AS SHOWN.

PROVIDE AND INSTALL NEW TRANSITIONS AS NEEDED

DIMENSIONS ON DRAWINGS ARE FOR REFERENCE ONLY, IT IS THE CONTRACTORS RESPONSIBILITY TO VERIFY ALL CONDITIONS.

IT WILL BE THE INSTALLER RESPONSIBILITY TO DISPOSE OF EXISTING CARPET FROM CAMPUS AS PART OF THE BID.

INSTALL DATES:
SUMMER 2024
TENTATIVE: MAY 20TH - JULY 26TH

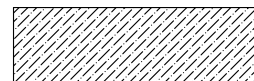

CPT 4: INTERFACE: "VIVA COLORES"
CAFE TOSTADO (106046)

BASE/TRANSITION:
RBI: JOHNSONITE: 63 BURNT UMBER

STROUP HALL - FIRST FLOOR PLAN

SCALE: 1/8" = 1'

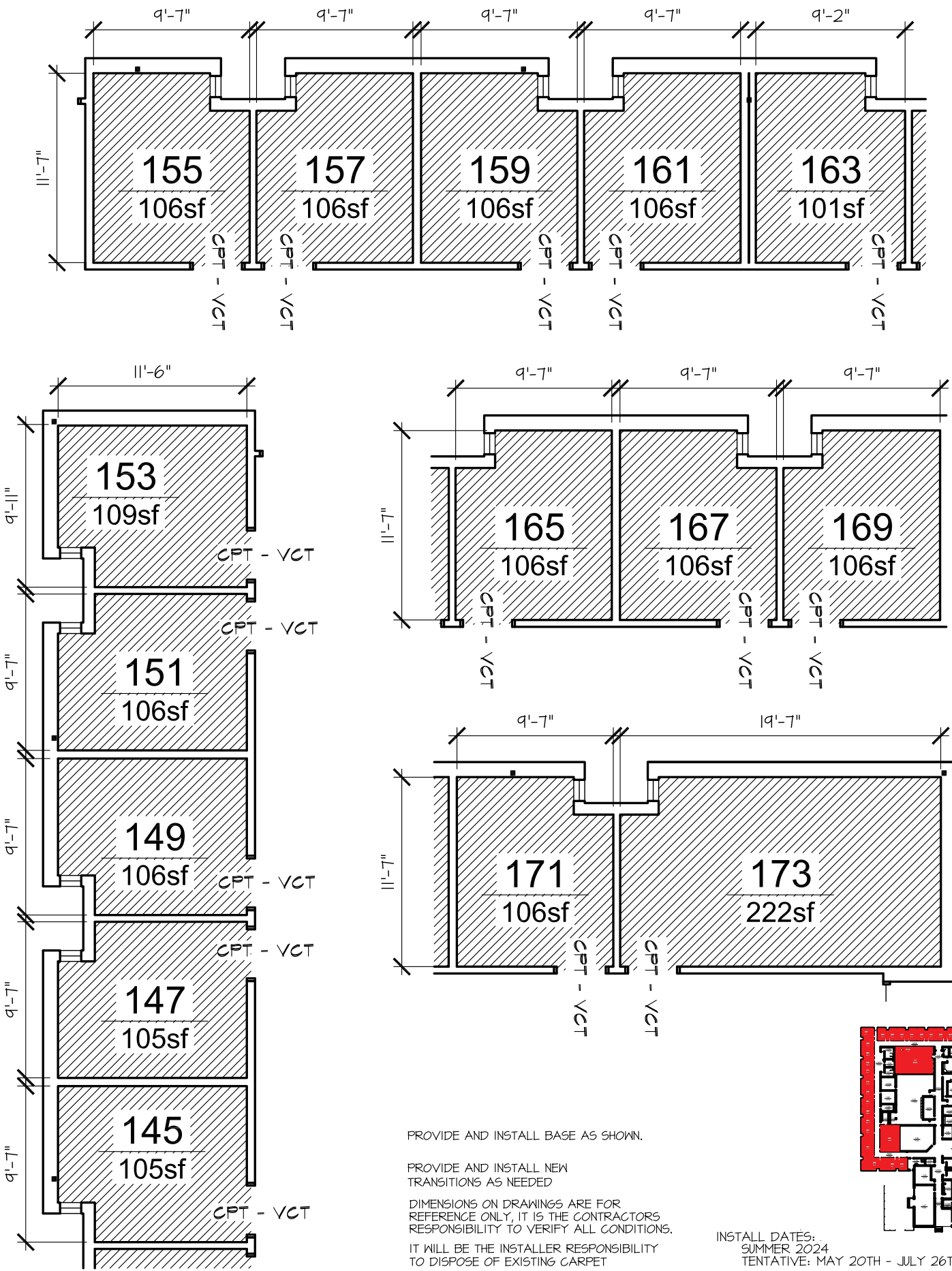

PROVIDE AND INSTALL BASE AS SHOWN.

PROVIDE AND INSTALL NEW TRANSITIONS AS NEEDED

DIMENSIONS ON DRAWINGS ARE FOR REFERENCE ONLY, IT IS THE CONTRACTORS RESPONSIBILITY TO VERIFY ALL CONDITIONS.

IT WILL BE THE INSTALLER RESPONSIBILITY TO DISPOSE OF EXISTING CARPET FROM CAMPUS AS PART OF THE BID.

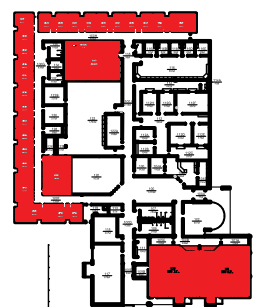

INSTALL DATES:
 SUMMER 2024
 TENTATIVE: MAY 20TH - JULY 26TH

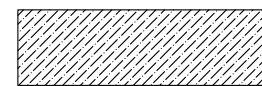

CPT 4: INTERFACE: "VIVA COLORES" CAFE TOSTADO (106046)

BASE/TRANSITION:
 RBI: JOHNSONITE: 63 BURNT UMBER

STROUP HALL - FIRST FLOOR PLAN

SCALE: 1/8" = 1'

TERMS AND CONDITIONS

1. It is the intent of Fort Hays State University (FHSU) to permit competitive bidding. It is the bidder's responsibility to advise the FHSU Purchasing Office, in writing, no later than three (3) business days before the bid closing date, if any specification or requirement described herein limits bidding to a single source.
2. Unless otherwise specified, Fort Hays State University reserves the right to accept or reject all or any part of your quotation, and to waive technicalities.
3. Offered payment discounts will NOT be considered in determining the low bid. The discount period begins on the date of delivery, or acceptance, or receipt of a correct invoice by the receiving agency, whichever is later.
4. Except as otherwise indicated, the merchandise quoted is in new condition.
5. Fort Hays State University reserves the right to award purchases by item, by group, or by lot, whichever is deemed to be in the university's best interest.
6. In the event of a tie for the low bid, the award will be made to the Kansas bidder.
7. Unit price will prevail in the event of extension error(s).
8. If awarded a purchase order, the bidder agrees to furnish the item(s) or provide the service(s) enumerated hereon at the price(s) quoted and in accordance with the conditions indicated.
9. If a bid indicates that an item quoted is functionally equivalent and it is purchased and found not to be comparable, Fort Hays State University reserves the right to return that item at the bidder's expense, and the bidder will be billed for the difference in cost between this bid and the successful bid.
10. If any portion of this bid is provided by a vendor other than the bidder, the bidder remains the prime contractor responsible for fulfilling all requirements of this bid.
11. Contracts or purchase orders resulting from this quotation may not be assigned without prior written consent of the FHSU Director of Purchasing.
12. The seller agrees to protect Fort Hays State University from all damages arising out of alleged patent infringement.
13. Partial payments will not be made, unless otherwise specified.
14. Bid results are available by written request with a check payable to Fort Hays State University for five dollars (\$5.00) per request, tax included, with a stamped, self-addressed envelope. Unless otherwise requested, your canceled check will serve as your receipt.
15. Any conviction for a criminal or civil offense that indicates a lack of business integrity or business honesty which currently, seriously and directly affects responsibility as a state contractor must be disclosed. This is to include (1) conviction of a criminal offense as an incident to obtaining or attempting to obtain a public or private contract of subcontract or in the performance of such contract of subcontract; (2) conviction under state or federal statutes of embezzlement, theft, forgery, bribery, falsification or destruction of records, receiving stolen property; (3) conviction under state or federal antitrust statutes; and (4) any other offense to be serious and compelling as to affect responsibility as a state contractor. For the purpose of this section, an individual or entity shall be presumed to have control of a company or organization if the individual or entity directly or indirectly, or action in concert with one or more individuals or entities, owns or controls twenty-five percent (25%) or more of its equity, or otherwise controls its management or policies. Failure to disclose an offense may result in disqualification of the bid or termination of the contract.
16. If any part of this contract (including any required installation) is fulfilled by any other contractor, the successful bidder remains responsible for completing all aspects of the work described herein.
17. Vendors who are new to the university should complete a vendor registration form found at: <http://www.fhsu.edu/purchasing/Vendor-Registration-Form>. A copy of the vendor's W-9 should also be submitted with your bid: <http://www.irs.gov/pub/irs-pdf/fw9.pdf?portlet=3>.

TAX CLEARANCE

Fort Hays State University strongly supports the State of Kansas Tax Clearance Process. Vendors submitting bids or proposals which exceed \$25,000 over the term of the contract shall include a copy of a Tax Clearance Certification Form with their submittal. Failure to provide this information may be cause for rejection of vendor's bid or proposal.

A "Tax Clearance" is a comprehensive tax account review to determine and ensure that the account is compliant with all primary Kansas Tax Laws administered by the Kansas Department of Revenue (KDOR) Director of Taxation. Information pertaining to a Tax Clearance is subject to change(s), which may arise as a result of a State Tax Audit, Federal Revenue Agent Report, or other lawful adjustment(s).

To obtain a Tax Clearance Certificate, you must:

- Go to <https://www.kdor.ks.gov/apps/taxclearance/Default.aspx> to request a Tax Clearance Certificate
- Return to the website the following working day to see if KDOR will issue the certificate
- If issued an official certificate, print it and attach it to your bid response
- If denied a certificate, engage KDOR in a discussion about why a certificate wasn't issued

Bidders (and their subcontractors) are expected to submit a current Tax Clearance Certificate with every event response.

Please Note: Individual and business applications are available. For applications entered prior to 5:00 PM Monday through Friday, results typically will be available the following business day. Tax clearance requests may be denied if the request includes incomplete or incorrect information.

Please Note: You will need to sign back into the KDOR website to view and print the official tax clearance certificate.

A copy of the Certification of Tax Clearance form received from the Kansas Department of Revenue should be sent along with the bid response(s) to:

Fort Hays State University
Purchasing Office
601 Park Street, Sheridan Hall 318
Hays, KS 67601

Failure to provide this information may be cause for rejection of vendor's bid or proposal.

Information about Tax Registration can be found at the following website:

<http://www.ksrevenue.org/forms-btreg.html>.

The FHSU Purchasing Office reserves the right to confirm tax status of all potential contractors and subcontractors prior to the release of a purchase order or contract award.

In the event that a current tax certificate is unavailable, the FHSU Purchasing Office reserves the right to notify a bidder (one that has submitted a timely event response) that they have to provide a current Tax Clearance Certificate within ten (10) calendar days, or FHSU may proceed with an award to the next lowest responsive bidder, whichever is determined by the Purchasing Director to be in the best interest of FHSU and the State.

**CERTIFICATION REGARDING
IMMIGRATION REFORM & CONTROL**

All Contractors are expected to comply with the Immigration and Reform Control Act of 1986 (IRCA), as may be amended from time to time. This Act, with certain limitations, requires the verification of the employment status of all individuals who were hired on or after November 6, 1986, by the Contractor as well as any subcontractor or sub-subcontractor. The usual method of verification is through the Employment Verification (I-9) Form. With the submission of this bid, the Contractor hereby certifies without exception that Contractor has complied with all federal and state laws relating to immigration and reform. Any misrepresentation in this regard or any employment of persons not authorized to work in the United States constitutes a material breach and, at the State's option, may subject the contract to termination and any applicable damages.

Contractor certifies that, should it be awarded a contract by the State, Contractor will comply with all applicable federal and state laws, standards, orders and regulations affecting a person's participation and eligibility in any program or activity undertaken by the Contractor pursuant to this contract. Contractor further certifies that it will remain in compliance throughout the term of the contract.

At the State's request, Contractor is expected to produce to the State any documentation or other such evidence to verify Contractor's compliance with any provision, duty, certification, or the like under the contract.

Contractor agrees to include this Certification in contracts between itself and any subcontractors in connection with the services performed under this contract.

Signature, Title of Contractor

Date

State of Kansas
Fort Hays State University
DA-146a (Rev. 12/19)

CONTRACTUAL PROVISIONS ATTACHMENT

Important: This form contains mandatory contract provisions and must be attached to or incorporated in all copies of any contractual agreement. If it is attached to the vendor/contractor's standard contract form, then that form must be altered to contain the following provision:

"The Provisions found in Contractual Provisions Attachment (Form DA-146a, Rev. 12/19), which is attached hereto, are hereby incorporated in this contract and made a part thereof."

The parties agree that the following provisions are hereby incorporated into the contract to which it is attached and made a part thereof.

- 1. Controlling Provisions:** It is expressly agreed that the terms of each and every provision in this attachment shall prevail and control over the terms of any other conflicting provision in any other document relating to and a part of the contract in which this attachment is incorporated. Any terms that conflict or could be interpreted to conflict with this attachment are nullified.
- 2. Disclaimer Of Liability:** No provision of this contract will be given effect that attempts to require Fort Hays State University or any of its affiliates ("University") to defend, hold harmless, or indemnify any contractor or third party for any acts or omissions. The terms, conditions, and limitations of liability of the State of Kansas, the University, and their employees are defined under the Kansas Tort Claims Act (K.S.A. 75-6101 et seq.).
- 3. Termination Due To Lack Of Funding Appropriation:** If, in the judgment of the Director of Accounts and Reports, Department of Administration, sufficient funds are not appropriated to continue the function performed in this agreement and for the payment of the charges hereunder, the University may terminate this agreement at the end of its current fiscal year. The University agrees to give written notice of termination to contractor at least 30 days prior to the end of its current fiscal year, and shall give such notice for a greater period prior to the end of such fiscal year as may be provided in this contract, except that such notice shall not be required prior to 90 days before the end of such fiscal year. Contractor shall have the right, at the end of such fiscal year, to take possession of any equipment provided under the contract for which it has not been paid. The University will pay contractor all regular contractual payments incurred through the end of such fiscal year, plus contractual charges incidental to the return of any such equipment. Upon termination of the agreement under this provision, title to any such equipment shall revert to contractor at the end of the University's current fiscal year. The termination of the contract pursuant to this paragraph shall not cause any penalty to be charged to the agency or the contractor.
- 4. Kansas Law and Venue:** All matters arising out of or related to this agreement shall be subject to, governed by, and construed according to the laws of the State of Kansas, and jurisdiction and venue of any suit arising out of or related to this agreement shall reside only in courts located in the State of Kansas.
- 5. Required Non-Discrimination Provision:** Contractor agrees to comply with all applicable state and federal anti-discrimination laws. Contractor specifically agrees: (a) to comply with the Kansas Act Against Discrimination (K.S.A. 44-1001 et seq.) and the Kansas Age Discrimination in Employment Act (K.S.A. 44-1111 et seq.) and the applicable provisions of the Americans With Disabilities Act (42 U.S.C. 12101 et seq.) (ADA) and to not discriminate against any person because of race, religion, color, sex, disability, national origin or ancestry, or age in the admission or access to, or treatment or employment in, its programs or activities; (b) to include in all solicitations or advertisements for employees, the phrase "equal opportunity employer"; (c) to comply with the reporting requirements set out at K.S.A. 44-1031 and K.S.A. 44-1116; (d) to include those provisions in every subcontract or purchase order so that they are binding upon such subcontractor or vendor; (e) that a failure to comply with the reporting requirements of (c) above or if the contractor is found guilty of any violation of such acts by the Kansas Human Rights Commission or if it is determined that the contractor has violated applicable provisions of ADA, such violation(s) shall constitute a breach of contract and the contract may be cancelled, terminated or suspended, in whole or in part, by the University. The provisions of this paragraph (except the provisions relating to the ADA) are not applicable to a contractor who employs fewer than four employees during the term of such contract or whose contracts with the University cumulatively total \$5,000 or less during the fiscal year.

Contractor shall abide by the requirements of 41 CFR §§ 60-1.4(a), 60-300.5(a) and 60-741.5(a). These regulations prohibit discrimination against qualified individuals based on their status as protected veterans or individuals with disabilities, and prohibit discrimination against all individuals based on their race, color, religion, sex, or national origin. Moreover, these regulations require that covered prime contractors and subcontractors take

affirmative action to employ and advance individuals in employment without regard to race, color, religion, sex, national origin, protected veteran status or disability.

6. **Acceptance Of Contract:** This contract shall not be considered accepted, approved or otherwise effective until the statutorily required approvals and certifications have been given.
7. **Arbitration, Damages, Warranties:** Notwithstanding any language to the contrary, no interpretation of this contract shall find that the University has agreed to binding arbitration, or the payment of damages or penalties. Further, the University does not agree to pay attorney fees, costs, or late payment charges beyond those available under the Kansas Prompt Payment Act (K.S.A. 75-6403), and no provision will be given effect that attempts to exclude, modify, disclaim or otherwise attempt to limit any damages or rights of action available to the University at law, including but not limited to the implied warranties of merchantability and fitness for a particular purpose.
8. **Authority To Contract:** By signing this contract, the representative of the contractor thereby represents that such person is duly authorized by the contractor to execute this contract on behalf of the contractor and that the contractor agrees to be bound by the provisions thereof.
9. **Responsibility For Taxes:** The University shall not be responsible for, nor indemnify a contractor for, any federal, state or local taxes which may be imposed or levied upon the subject matter of this contract.
10. **Insurance:** The University shall not be required to purchase any insurance against loss or damage to property or any other subject matter relating to this contract, nor shall this contract require the University to establish a "self-insurance" fund to protect against any such loss or damage.
11. **Information/Confidentiality:** As a state agency, the University's contracts are generally public records. Accordingly, no provision of this contract shall restrict the University's ability to produce this contract in response to a lawful request or from otherwise complying with the Kansas Open Records Act (K.S.A. 45-215 et seq.). Moreover, no provision of this contract shall be construed as limiting the Legislative Division of Post Audit from having access to information pursuant to K.S.A. 46-1101 et seq.
12. **The Eleventh Amendment:** The Eleventh Amendment is an inherent and incumbent protection of the State of Kansas and need not be reserved, but the University here reiterates that nothing in or related to this contract shall be deemed a waiver of the Eleventh Amendment.
13. **Campaign Contributions / Lobbying:** Funds provided through a grant award or contract shall not be given or received in exchange for the making of a campaign contribution. No part of the funds provided through this contract shall be used to influence or attempt to influence an officer or employee of any State of Kansas agency or a member of the Legislature regarding any pending legislation or the awarding, extension, continuation, renewal, amendment or modification of any government contract, grant, loan, or cooperative agreement.
14. **Privacy of Student Records:** Contractor understands that the University is subject to FERPA (Family Educational Rights and Privacy Act, 20 U.S.C. § 1232g) and agrees to handle any student education records it receives pursuant to this Agreement in a manner that enables the University to be compliant with FERPA and its regulations. Contractor agrees to protect the privacy of student data and educational records in a commercially reasonable manner and shall not transmit, share, or disclose any data about a student without the student's written consent, except to other University officials who seek the information within the context of his/her professionally assigned responsibilities and used within the context of official University business. Contractor shall promptly report to the University any disclosure of University's student educational records.
15. **Boycotts of Israel Prohibited:** Kansas 2018 HB 2482 generally prohibits the University from entering into a contract with a company to acquire or dispose of services, supplies, information technology or construction, unless such company submits a written certification that such company is not currently engaged in a boycott of Israel. For the purposes of this Section, "company" means an organization, association, corporation, partnership, venture or other entity, its subsidiary or affiliate, that exists for profitmaking purposes or to otherwise secure economic advantage. Accordingly, by executing this contract, Contractor hereby certifies that it is not currently engaged in a boycott of Israel.
16. **Harassment Policy:** Fort Hays State University prohibits sexual harassment, discrimination, and retaliation. The University's applicable policies on sexual harassment, discrimination, and retaliation are available at <https://fhsu.edu/policies/documents/harassment-policy/index.pdf> and include the procedures for submitting a complaint of sexual harassment, discrimination, or retaliation, including an anonymous complaint. Contractor and its employees, officials, agents, or subcontractors shall at all times comply with the University's policies on sexual harassment, discrimination, and retaliation.