PROJECT MANUAL

For

Arlington County DHS Group Home

Located at

1212 S. Irving Street
Arlington County
Arlington, Virginia 22204

October 21, 2020
Bid Issue

Architect's Project Number 19296-01

Prepared by:

ARCHITECTURE, INC.
1902 Campus Commons Drive
Suite 101
Reston, Virginia 20191

703-476-3900

THIS SHEET LEFT INTENSIONALLY BLANK

New Construction

Arlington County DHS Group Home
1212 S. Irving Street
Arlington, Virginia 22204

Architect's Project #19296-01

SPECIFICATION INDEX – Bid Set

DIVISION 00 BIDDING AND CONTRACT

To Be Prepared and Issued Under Separate Cover by Arlington County Government

DIVISION 01 GENERAL REQUIREMENTS

011000 SUMMARY
012500 SUBSTITUTION PROCEDURES
012600 CONTRACT MODIFICATION PROCEDURES
012900 PAYMENT PROCEDURES
013100 PROJECT MANAGEMENT AND COORDINATION
013200 CONSTRUCTION PROGRESS DOCUMENTATION
013233 PHOTOGRAPHIC DOCUMENTATION
014200 REFERENCES
015000 TEMPORARY FACILITIES AND CONTROLS
015100 TEMPORARY INDOOR AIR QUALITY
015639 TEMPORARY TREE AND PLANT PROTECTION
016000 PRODUCT REQUIREMENTS
017419 CONSTRUCTION WASTE MANAGEMENT AND DISPOSAL
017700 CLOSEOUT PROCEDURES
017823 OPERATION AND MAINTENANCE DATA
017839 PROJECT RECORD DOCUMENTS
017900 DEMONSTRATION AND TRAINING
018113.63 SF SUSTAINABLE DESIGN REQUIREMENTS - VIRIDIANT NET-ZERO
ADMINISTRATIVE REGULATIONS
VIRIDIANT EARTHCRAFT HOUSE TECHNICAL GUIDELINES
VIRIDIANT NET-ZERO PROGRAM™
ARLINGTON GROUP HOUSE - WHOLE BUILDING ENERGY SIMULATION
019113 GENERAL COMMISSIONING REQUIREMENTS

DIVISION 02 EXISTING CONDITIONS

020100 SUBSURFACE INVESTIGATION
024116 STRUCTURE DEMOLITION

DIVISION 03 CONCRETE

031119 INSULATING CONCRETE FORMING
033000 CAST-IN-PLACE CONCRETE
035413 GYPSUM CEMENT UNDERLAYMENT

DIVISION 04	MASONRY
042200	CONCRETE UNIT MASONRY
044313.16	ADHERED STONE MASONRY VENEER
047200	CAST STONE MASONRY
DIVISION 05	METALS
051200	STRUCTURAL STEEL FRAMING
055000	METAL FABRICATIONS
DIVISION 06	WOOD AND PLASTICS
061000	ROUGH CARPENTRY
061200	STRUCTURAL INSULATED PANELS
061600	SHEATHING
062013	EXTERIOR FINISH CARPENTRY
064023	INTERIOR ARCHITECTURAL WOODWORK
064113	WOOD-VENEER-FACED ARCHITECTURAL CABINETS
064116	PLASTIC-LAMINATE-FACED ARCHITECTURAL CABINETS
DIVISION 07	THERMAL AND MOISTURE PROTECTION
071113	BITUMINOUS DAMPPROOFING
071326	SELF-ADHERING SHEET WATERPROOFING
072100	THERMAL INSULATION
072413	POLYMER-BASED EXTERIOR INSULATION AND FINISH SYSTEM (EIFS)
072600	VAPOR RETARDERS
072726	FLUID-APPLIED MEMBRANE AIR BARRIERS
074113.16	STANDING SEAM METAL ROOF PANELS
074646	FIBER-CEMENT SIDING
075423	THERMOPLASTIC POLYOLEFIN (TPO) ROOFING
076200	SHEET METAL FLASHING AND TRIM
077200	ROOF ACCESSORIES
077253	SNOW GUARDS
079200	JOINT SEALANTS
DIVISION 08	OPENINGS
081113	HOLLOW METAL DOORS AND FRAMES
081423	IMPACT RESISTANT INTERIOR PANEL DOORS
082100	FIBERGLASS DOORS
083113	ACCESS DOORS AND FRAMES
085313	VINYL WINDOWS
087100	DOOR HARDWARE
088000	GLAZING
088300	MIRRORS
DIVISION 09	FINISHES
092216	NON-STRUCTURAL METAL FRAMING
092900	GYPSON BOARD
093013	CERAMIC TILING
096513	RESILIENT BASE AND ACCESSORIES
096516	RESILIENT SHEET FLOORING
096519	RESILIENT TILE FLOORING
097200	WALL COVERING

099113	EXTERIOR PAINTING
099123	INTERIOR PAINTING
099300	STAINING AND TRANSPARENT FINISHING
DIVISION 10	SPECIALTIES
102600	WALL AND DOOR PROTECTION
102800	TOILET, BATH, AND LAUNDRY ACCESSORIES
104416	FIRE EXTINGUISHERS
DIVISION 11	EQUIPMENT
113013	RESIDENTIAL APPLIANCES AND EQUIPMENT
DIVISION 12	FURNISHINGS
123623.13	PLASTIC-LAMINATE-CLAD COUNTERTOPS
123661.16	SOLID SURFACING COUNTERTOPS
123661.19	QUARTZ AGGLOMERATE COUNTERTOPS
DIVISION 13	SPECIAL CONSTRUCTION
Not Used	
DIVISION 14	CONVEYING SYSTEMS
142400	LIMITED-USE-LIMITED-APPLICATION ELEVATORS
DIVISION 21	FIRE SUPPRESSION
210000	FIRE SUPPRESSION BASIC REQUIREMENTS
210500	COMMON WORK RESULTS FOR FIRE SUPPRESSION
211300	FIRE SUPPRESSION SPRINKLER SYSTEMS
DIVISION 22	PLUMBING
220000	PLUMBING BASIC REQUIREMENTS
220516	EXPANSION FITTINGS AND LOOPS FOR PLUMBING PIPING
220519	PLUMBING DEVICES
220523	GENERAL-DUTY VALVES FOR PLUMBING PIPING
220529	HANGERS AND SUPPORTS FOR PLUMBING PIPING AND EQUIPMENT
220553	IDENTIFICATION FOR PLUMBING PIPING AND EQUIPMENT
220593	TESTING, ADJUSTING, AND BALANCING FOR PLUMBING
220700	PLUMBING INSULATION
220800	COMMISSIONING OF PLUMBING
221000	PLUMBING PIPING
223000	PLUMBING EQUIPMENT
224000	PLUMBING FIXTURES
DIVISION 23	HEATING VENTILATING AND AIR CONDITIONING
230000	HEATING, VENTILATING AND AIR CONDITIONING (HVAC) BASIC REQUIREMENTS
230513	COMMON MOTOR REQUIREMENTS FOR HVAC EQUIPMENT
230519	METERS AND GAUGES FOR HVAC PIPING
230523	GENERAL-DUTY VALVES FOR HVAC PIPING
230529	HANGERS AND SUPPORTS FOR HVAC PIPING, DUCTWORK AND EQUIPMENT
230548	VIBRATION CONTROLS FOR HVAC EQUIPMENT

230553 IDENTIFICATION FOR HVAC PIPING, DUCTWORK AND EQUIPMENT
 230593 TESTING, ADJUSTING, AND BALANCING FOR HVAC
 230700 HVAC INSULATION
 230800 COMMISSIONING OF HVAC
 230913 VARIABLE FREQUENCY DRIVES
 230933 ELECTRIC AND ELECTRONIC CONTROL SYSTEM FOR HVAC
 232113 HVAC PIPING
 232113.33 GROUND-LOOP HEAT-PUMP PIPING
 232116 HYDRONIC PIPING SPECIALTIES
 232123 HYDRONIC PUMPS
 232500 HVAC WATER TREATMENT
 233100 HVAC DUCTS AND CASINGS
 233300 AIR DUCT ACCESSORIES
 234000 HVAC FANS
 233700 AIR OUTLETS AND INLETS
 234000 HVAC AIR CLEANING DEVICES
 238126 SMALL SPLIT SYSTEM AND UNITARY HVAC EQUIPMENT

DIVISION 26

ELECTRICAL

260000 ELECTRICAL BASIC REQUIREMENTS
 260509 EQUIPMENT WIRING
 260519 LOW-VOLTAGE ELECTRICAL POWER CONDUCTORS AND CABLES
 260526 GROUNDING AND BONDING FOR ELECTRICAL SYSTEMS
 260529 HANGERS AND SUPPORTS FOR ELECTRICAL SYSTEMS AND EQUIPMENT
 260533 RACEWAYS
 260534 BOXES
 260553 IDENTIFICATION FOR ELECTRICAL SYSTEMS
 260573 ELECTRICAL DISTRIBUTION SYSTEM STUDIES
 260800 COMMISSIONING OF ELECTRICAL
 260923 OCCUPANCY AND VACANCY SENSORS
 262416 PANELBOARDS
 262713 ELECTRICAL METERING
 262726 WIRING DEVICES
 262800 OVERCURRENT PROTECTIVE DEVICES
 263100 PHOTOVOLTAIC SYSTEMS
 263214 GAS FIRED ENGINE GENERATORS
 263600 TRANSFER SWITCHES
 265100 LIGHTING

DIVISION 27

COMMUNICATIONS

Not Used

DIVISION 28

ELECTRONIC SAFETY AND SECURITY

280001 ELECTRONIC SAFETY BASIC REQUIREMENTS
 283100 FIRE DETECTION AND ALARM

TABLE OF CONTENTS

Project No.: 19296.01
Arlington County DHS Group Home

DIVISION 31	EARTHWORK
311000	SITE CLEARING
312000	EARTH MOVING
313116	TERMITE CONTROL
DIVISION 32	EXTERIOR IMPROVEMENTS
321316	DECORATIVE CONCRETE PAVING
329200	TURF AND GRASSES
329300	PLANTS
DIVISION 33	UTILITIES
330500	COMMON WORK RESULTS FOR UTILITIES WITH APPENDIX

END TABLE OF CONTENTS

THIS PAGE INTENTIONALLY LEFT BLANK

SECTION 011000 - SUMMARY

PART 1 - GENERAL

1.1 RELATED DOCUMENTS

- A. Drawings and general provisions of the Contract, including General and Supplementary Conditions and other Division 01 Specification Sections, apply to this Section.

1.2 SUMMARY

- A. Section Includes:

- 1. Project information.
- 2. Work covered by Contract Documents.
- 3. Phased construction.
- 4. Work by Owner.
- 5. Work under separate contracts.
- 6. Access to site.
- 7. Coordination with occupants.
- 8. Work restrictions.
- 9. Specification and Drawing conventions.
- 10. Miscellaneous provisions.

- B. Related Requirements:

- 1. Section 015000 "Temporary Facilities and Controls" for limitations and procedures governing temporary use of Owner's facilities.

- C. Common Definitions Used in the Specification:

- 1. Owner – Arlington County and its various sub entities.
- 2. Architect – Designer of Record hired by the County as a consultant.
- 3. Engineer – Designer of Record hired by the county or by a consultant or contractor under contract with the County
- 4. Project Manager – Arlington Count Project Officer.
- 5. Construction Manager – Consultant hired by the County to assist the Project Officer.
- 6. Contractor – General Contractor hired by the County to construct the project or subcontractor under contract to the General Contractor.

1.3 PROJECT INFORMATION

A. Project Identification: DHS Group Home

1. Project Location: 1212 S. Irving Street. Arlington, VA 22204

B. Owner: Arlington County Board

1. Owner's Representative:
Cynthia Wilson, AIA, LEED AP
DES-Facilities Design & Construction
Cwilson@arlingtonva.us
703-228-4438

C. Architect:

1. Architecture, Incorporated. 1902 Campus Commons Drive, Suite 101 Reston, VA 20191, Attention: Katie Ray. 703.476.3900

D. Architect's Consultants: Architect has retained the following design professionals who have prepared designated portions of the Contract Documents:

1. Mechanical / Electrical / Plumbing / Fire Protection Engineers: Interface Engineering, Inc, 2999 M Street NW, Suite 270, Washington, DC 20036, Tele 202.370.9555.
2. Structural Engineer: BEI Structural Engineers, 3930 Pender Drive, Suite 175, Fairfax, VA 22030, Tele 703.890.5000.
3. Civil / Landscape Engineer: Walter L. Phillips, 207 Park Avenue, Falls Church, VA 22046, Tele 703.532.6163.

E. Other Owner Consultants: Owner has retained the following design professionals who have prepared designated portions of the Contract Documents:

1. None at this time.

F. Contractor: **"To be determined"** has been engaged as Contractor for this Project.

G. Web-Based Project Software:

1. See Section 013100 "Project Management and Coordination." for requirements for establishing administering and using web-based Project software.

1.4 WORK COVERED BY CONTRACT DOCUMENTS

A. The Work of Project is defined by the Contract Documents and consists of the following:

1. The Work is for a two-story plus basement Group Home with concrete foundation walls, slab-on-grade basement floor slab and combustible construction for two floors and roof. Project will be complete and includes existing building demolition, site work, landscaping, building framing, roofing systems, exterior finishes, interior finishes,

residential appliances, plumbing systems and fixtures, HVAC systems, and electrical systems and lighting.

B. Type of Contract:

1. Project will be constructed under a single prime contract procured as a Design Bid Build, Lowest Qualified Bid format.

1.5 PROJECT TEAM BUILDING EXERCISE

- A. Within 21 days after the Notice to Proceed, the Contractor shall sponsor a team building workshop, held virtually, and chaired by an independent facilitator experienced in construction project team building. Participants shall include Contractor's key Project personnel, Contractor's project executive, the Architect and County staff. The workshop shall be a maximum of no more than three hours duration.

1.6 CONSTRUCTION PERMITS

- A. The County will obtain and pay fees for the Building Construction Permit and Certificate of Occupancy. The Contractor shall be solely responsible for thoroughly understanding, obtaining, and paying for all other permits requirement as it pertains to work under this Contract. All Permits obtained by The County are the responsibility of the Contractor to track and monitor for renewal. The Contractor will notify the County at least 30 days prior to the permit expiration date.
- B. Permits required for the project may include some or all of the following, but are not limited to:
 - a. County Land Disturbing Activities (LDA) permit
 - b. County Public Right-Of-Way (PROW) permit
 - c. County Transportation Right-Of-Way(TROW) permit
- C. The County Demolition permit will be obtained by the County prior to the start of Work. These permits shall be transferred to the Contractor as the named permittee and/or responsible party prior to the start of Work.
- D. The Contractor is responsible for paying and obtaining an Arlington County PROW and TROW permits for any work within the Arlington County Right-Of-Way. The Contractor is responsible for obtaining all other required permits not obtained by the County. The Contractor is responsible for investigating and satisfying all County and VDOT Permit requirements.
- E. The Contractor shall provide a Responsible Land Disturber (RLD) that meets all the required qualifications of the permits. The Contractor shall complete and sign the RLD certificate and submit to the County Project Officer in order to receive the Demolition Permit and prior to the start of Work
- F. Any activities requiring welding or soldering shall require a Permit from Arlington County. The permit shall include time frame for welding or soldering, certification of welder and method of odor and/or smoke mitigation. The permit shall be submitted for work no greater than 5 days in duration and shall be submitted a 3 day in advance of the associated work. The contractor shall

receive written authorization for the permit from Arlington County prior to initiating work requiring the permit.

- G. The Contractor shall be responsible for scheduling and coordinating inspections and receipts of local or state permits/approvals/certifications for any tanks, piping and associated appurtenances, which are constructed, installed tested or removed as part of this contract.

1.7 INSPECTIONS

- A. It is the contractor's responsibility to schedule all required inspections with either of the appropriate parties (ISD, DES, Inspection Agency, VDOT, etc....).
- B. The contractor is required to fully understand the County inspection process and is responsible for researching and obtaining all required permits and or non-permit reviews as identified by Arlington County Government. See www.arlingtonva.us for applicable requirements.

1.8 PHASED CONSTRUCTION (Schedule Requirements)

- A. All Work to be completed in a single phase.

1.9 WORK BY OWNER

- A. General: Cooperate fully with Owner so work may be carried out smoothly, without interfering with or delaying work under this Contract or work by Owner. Coordinate the Work of this Contract with work performed by Owner.
- B. Preceding Work: Owner will perform the following construction operations at Project site. Those operations are scheduled to be substantially complete before work under this Contract begins.
 - 1. Furniture Moving Contractor – TBD – Will move in and out owner supplied furniture prior to the start of work and replacement at end of the project or during as required by the building permit.
- C. Separate Work: Owner will perform the following construction operations at Project site. Those operations will be conducted simultaneously with Work under this Contract. The Contractor shall afford separate contractors reasonable access to the project, including storage of their material and execution of their work, and shall properly coordinate and connect their work with the work of other such contractors, per the County's General Conditions.
 - 1. Security Contractor – ADT.
 - 2. Telephone/ Audio/ Video equipment and cabling – Vision Technology
 - 3. Archeological Monitoring after Demolition & during Excavation in coordination with Owner's Archeologist – AECOM
 - 4. Interior (Furniture) Contractor – KI

5. Structural Testing (Soil Compaction, Reinforced Concrete, concrete paving and mortar) – Hilles & Carnes
6. Commissioning Agent – Jacobs Inc.

1.10 OWNER-FURNISHED PRODUCTS

A. Owner-Furnished Products:

1. See contract documents for any Owner-Furnished Items
2. Moving in of Furniture / Furnishings – KI

1.11 ACCESS TO SITE

- A. The Contractor's use of the premises is only limited by the Owner's right to perform construction operations with its own forces or to employ separate contractors on portions of the project.
- B. Staging: The staging area will be confined to the area defined and established with the County. No material will be staged on the sidewalks, other areas around the other buildings. The contractor must visit the site prior to the bid to familiarize themselves with the existing conditions and staging area. The contractor is responsible for coordinating, furnishing and implementing any Maintenance of Traffic (MOT) required for staging operations.
- C. Photography: Contractor shall maintain a photographic record of the project both with weekly progress photos and time-lapsed videos. This is to include photos taken from demolition, pre-construction, construction and construction completion. Electronic access to progress photos and time-lapsed videos must be available to County representatives. Weekly photos should be dated by the end of each month when you submit monthly request for payment.
- D. The Contractor shall assume full responsibility for materials and equipment stored on-site.

1.12 WORK RESTRICTIONS

- A. Work Restrictions, General: Comply with restrictions on construction operations.
 1. Comply with limitations on use of public streets and with other requirements of authorities having jurisdiction.
- B. On-Site Work Hours: Limit exterior construction activities, excepting worker arrival at the site to times between the working hours of 7:00 a.m. to 6:30 p.m., Monday through Friday, and to times between 10:00am and 6:30pm on weekends and County holidays, unless otherwise coordinated. There are no restrictions for the start and end time for 'quiet' interior construction activities.
- C. If there is a need to have early weekday morning, and /or weekend work; the following must be followed:

1. Weekend Hours: Permitted between 8:00 am and 3:00 pm on weekends and County holidays, when approved in writing 24 hours prior to any activity start by the County Project Officer.
 2. Early Morning Hours: Permitted with approval in writing 24 hours prior to any activity start by the County Project Officer.
- D. Noise, Vibration, and Odors: Coordinate operations that may result in medium to high levels of noise and vibration, odors with Owner.
- E. Restricted Substances: Use of tobacco, e-cigarettes or vaping products and other controlled substances on Project site is not permitted.
- F. Employee Screening: Comply with Owner's requirements for drug, COVID 19 and background screening of Contractor personnel working on Project site.
1. Maintain list of approved screened personnel with Owner's representative.
- G. Construction/ Contractor/ Subcontractor Parking
1. This is a residential neighborhood, therefore all street parking are regulated by the authority having jurisdiction. There will not be designated street parking spaces allowed for vehicles belonging to the Contractor and their sub-Contractors.
 2. All on-site parking for construction will be provided by the contractor at his determination and discretion.
- H. Delivery of Building Material and Removal of Trash
1. The Contractor shall not obstruct entry to the roadways and at any time for the delivery of building materials and the removal of all refuse, rubbish, scrap materials and debris. The Contractor shall use designated areas for loading, delivery and removal of debris/trash. Coordinate any materials or containers leaving the site.
- 1.13 SPECIFICATION AND DRAWING CONVENTIONS
- A. It is the contractor's responsibility to review and understand drawings and specifications. Any discrepancies or issues shall be addressed via an RFI prior to bid day. Any discrepancies brought up after bid day are subject to non-payment by the County and the greater condition shall be assumed as included in the contract sum.
- B. Specification Content: The Specifications use certain conventions for the style of language and the intended meaning of certain terms, words, and phrases when used in particular situations. These conventions are as follows:
1. Imperative mood and streamlined language are generally used in the Specifications. The words "shall," "shall be," or "shall comply with," depending on the context, are implied where a colon (:) is used within a sentence or phrase.
 2. Specification requirements are to be performed by Contractor unless specifically stated otherwise.

- C. Division 01 General Requirements: Requirements of Sections in Division 01 apply to the Work of all Sections in the Specifications.
- D. Drawing Coordination: Requirements for materials and products identified on Drawings are described in detail in the Specifications. One or more of the following are used on Drawings to identify materials and products:
 - 1. Terminology: Materials and products are identified by the typical generic terms used in the individual Specifications Sections.
 - 2. Abbreviations: Materials and products are identified by abbreviations published as part of the U.S. National CAD Standard and scheduled on Drawings.
 - 3. Keynoting: Materials and products are identified by reference keynotes referencing Specification Section numbers found in this Project Manual.

1.14 CONSTRUCTION STANDARDS

- A. All work shall conform to project plans, specifications and supplementary specifications along with the current edition of following County and State Construction Standards, as applicable:
 - 1. The **Arlington County Department of Environmental Services (DES) Construction Standards and Specifications**, a copy of which may be downloaded at no charge from the internet at:
<http://arlingtonva.s3.amazonaws.com/wp-content/uploads/sites/21/2013/12/Construction-Specifications-9-30-13.pdf>
 - 2. The **Arlington County Department of Environmental Services (DES) Traffic Signal & Streetlight Specifications**, a copy of which may be downloaded at no charge from the internet at:
<http://arlingtonva.s3.amazonaws.com/wp-content/uploads/sites/21/2013/12/Traffic-Signal-and-Street-Light-Specifications.pdf>
 - 3. The **Arlington County Department of Environmental Services (DES) Streetlight Specifications**, a copy of which may be downloaded at no charge from the internet at:
<https://transportation.arlingtonva.us/streets/street-lights/lighting-standards-specifications-updates/>
 - 4. The **Arlington County Department of Environmental Services (DES) Pavement Marking Specifications**, a copy of which may be downloaded at no charge from the internet at:
<http://transportation.arlingtonva.us/streets/traffic-signals/>
 - 5. The **Arlington County Department of Parks and Recreation (DPR) Specifications**, a copy of which may be downloaded at no charge from the internet at:
<http://parks.arlingtonva.us/design-standards/>
 - 6. The **Arlington County Department of Environmental Services (DES) Dichlorination and Disposal Procedures**, a copy of which may be downloaded at no charge from the internet at:
<http://topics.arlingtonva.us/building/discharging-chlorinated-water/>

7. The **Virginia Department of Transportation (VDOT) Road and Bridge Standards and Specifications**, a copy of which may be downloaded at no charge from the internet at: http://www.virginiadot.org/business/locdes/Standards_TOC.asp and <http://www.virginiadot.org/business/const/spec-default.asp>
8. The **Virginia Department of Transportation (VDOT) – • The Virginia Work Area Protection Manual (WAPM)** found on the internet at: <http://www.virginiadot.org/business/trafficeng-WZS.asp>
9. **Manual on Uniform Traffic Control Devices(MUTCD)**, a copy of which may be downloaded at no charge from the internet at: http://mutcd.fhwa.dot.gov/pdfs/2009r1r2/pdf_index.htm
10. The **Virginia Department of Transportation (VDOT) – Supplement to the MUTCD** found on the internet at: http://www.virginiadot.org/business/virginia_mutcd_supplement.asp

PART 2 - PRODUCTS (Not Used)

PART 3 - EXECUTION (Not Used)

END OF SECTION 011000

Copyright 2015 by The American Institute of Architects (AIA)

SECTION 012500 - SUBSTITUTION PROCEDURES

PART 1 - GENERAL

1.1 RELATED DOCUMENTS

- A. Drawings and general provisions of the Contract, including General and Supplementary Conditions and other Division 01 Specification Sections, apply to this Section.

1.2 SUMMARY

- A. Section includes administrative and procedural requirements for substitutions.
- B. Related Requirements:
 - 1. Section 016000 "Product Requirements" for requirements for submitting comparable product submittals for products by listed manufacturers.

1.3 DEFINITIONS

- A. Substitutions: Changes in products, materials, equipment, and methods of construction from those required by the Contract Documents and proposed by Contractor.
 - 1. Substitutions for Cause: Changes proposed by Contractor that are required due to changed Project conditions, such as unavailability of product, regulatory changes, or unavailability of required warranty terms.
 - 2. Substitutions for Convenience: Changes proposed by Contractor or Owner that are not required in order to meet other Project requirements but may offer advantage to Contractor or Owner.

1.4 ACTION SUBMITTALS

- A. Substitution Requests: Submit three copies of each request for consideration. Identify product or fabrication or installation method to be replaced. Include Specification Section number and title and Drawing numbers and titles.
 - 1. Submit 3 copies of each request for substitution for consideration. Submit requests in the form and in accordance with procedures required for Change Order proposals
 - 2. Documentation: Show compliance with requirements for substitutions and the following, as applicable:
 - a. Statement indicating why specified product or fabrication, or installation method cannot be provided, if applicable.

- b. Coordination of information, including a list of changes or revisions needed to other parts of the Work and to construction performed by Owner and separate contractors that will be necessary to accommodate proposed substitution.
 - c. Detailed comparison of significant qualities of proposed substitutions with those of the Work specified. Include annotated copy of applicable Specification Section. Significant qualities may include attributes, such as performance, weight, size, durability, visual effect, sustainable design characteristics, warranties, and specific features and requirements indicated. Indicate deviations, if any, from the Work specified.
 - d. Product Data, including drawings and descriptions of products and fabrication and installation procedures.
 - e. Samples, where applicable or requested.
 - f. Certificates and qualification data, where applicable or requested.
 - g. List of similar installations for completed projects, with project names and addresses as well as names and addresses of architects and owners.
 - h. Material test reports from a qualified testing agency, indicating and interpreting test results for compliance with requirements indicated.
 - i. Research reports evidencing compliance with building code in effect for Project, from ICC-ES.
 - j. Detailed comparison of Contractor's construction schedule using proposed substitutions with products specified for the Work, including effect on the overall Contract Time. If specified product or method of construction cannot be provided within the Contract Time, include letter from manufacturer, on manufacturer's letterhead, stating date of receipt of purchase order, lack of availability, or delays in delivery.
 - k. Cost information, including a proposal of change, if any, in the Contract Sum.
 - l. Contractor's certification that proposed substitution complies with requirements in the Contract Documents, except as indicated in substitution request, is compatible with related materials and is appropriate for applications indicated.
 - m. Contractor's waiver of rights to additional payment or time that may subsequently become necessary because of failure of proposed substitution to produce indicated results.
3. Architect's Action: If necessary, Architect will request additional information or documentation for evaluation within seven days of receipt of a request for substitution. Architect will notify Contractor of acceptance or rejection of proposed substitution within 15 days of receipt of request, or seven days of receipt of additional information or documentation, whichever is later.
- a. Forms of Acceptance: Change Order, Construction Change Directive, or Architect's Supplemental Instructions for minor changes in the Work.
 - b. Use product specified if Architect does not issue a decision on use of a proposed substitution within time allocated.

1.5 QUALITY ASSURANCE

- A. Compatibility of Substitutions: Investigate and document compatibility of proposed substitution with related products and materials. Engage a qualified testing agency to perform compatibility tests recommended by manufacturers.

1.6 PROCEDURES

- A. Coordination: Revise or adjust affected work as necessary to integrate work of the approved substitutions.

1.7 SUBSTITUTIONS

- A. Substitutions for Cause: Submit requests for substitution immediately on discovery of need for change, but not later than 15 days prior to time required for preparation and review of related submittals.

1. Conditions: Architect will consider Contractor's request for substitution when the following conditions are satisfied. If the following conditions are not satisfied, Architect will return requests without action, except to record noncompliance with these requirements:

- a. Requested substitution is consistent with the Contract Documents and will produce indicated results and revisions to Contract Documents are not required.
- b. Requested substitution provides sustainable design characteristics that specified product provided for compliance with Viridian Earthcraft Residential requirements. The stated County Goal is Viridian Net-Zero for this project.
- c. Substitution request is fully documented and properly submitted.
- d. Requested substitution will not adversely affect Contractor's construction schedule.
- e. Requested substitution has received necessary approvals of authorities having jurisdiction.
- f. Requested substitution is compatible with other portions of the Work.
- g. Requested substitution has been coordinated with other portions of the Work.
- h. Requested substitution provides specified warranty.
- i. If requested substitution involves more than one contractor, requested substitution has been coordinated with other portions of the Work, is uniform and consistent, is compatible with other products, and is acceptable to all contractors involved.
- j. The request is timely, fully documented and properly submitted. The specified product or method of construction can be provided within the Contract Time. The request will not be considered if the product or method cannot be provided as a result of failure to pursue the Work promptly or coordinate activities properly.
- k. A substantial advantage is offered the Owner, in terms of cost, time, energy conservation or other considerations of merit, after deducting offsetting responsibilities the Owner may be required to bear. Additional responsibilities for the Owner may include additional compensation to the A/E for redesign and evaluation services, increased cost of other construction by the Owner or separate Contractors, and similar considerations.

- B. Substitutions for Convenience: Not allowed.

PART 2 - PRODUCTS (Not Used)

PART 3 - EXECUTION (Not Used)

END OF SECTION 012500

Copyright 2015 by The American Institute of Architects (AIA)

SECTION 012600 - CONTRACT MODIFICATION PROCEDURES

PART 1 - GENERAL

1.1 RELATED DOCUMENTS

- A. Drawings and general provisions of the Contract, including General and Supplementary Conditions and other Division 01 Specification Sections, apply to this Section.

1.2 SUMMARY

- A. Section includes administrative and procedural requirements for handling and processing Contract modifications.
- B. Related Requirements:
 - 1. Section 012500 "Substitution Procedures" for administrative procedures for handling requests for substitutions made after the Contract award.

1.3 MINOR CHANGES IN THE WORK

- A. Architect will issue through the Owner supplemental instructions authorizing minor changes in the Work, not involving adjustment to the Contract Sum or the Contract Time, on AIA Document G710.

1.4 PROPOSAL REQUESTS

- A. Owner-Initiated Proposal Requests: The Owner will issue a detailed description of proposed changes in the Work that may require adjustment to the Contract Sum or the Contract Time. If necessary, the description will include supplemental or revised Drawings and Specifications.
 - 1. Work Change Proposal Requests issued by the Owner are not instructions either to stop work in progress or to execute the proposed change.
 - 2. Within time specified in Proposal Request or 14 days, when not otherwise specified, after receipt of Proposal Request, submit a quotation estimating cost adjustments to the Contract Sum and the Contract Time necessary to execute the change.
 - a. Include a list of quantities of products required or eliminated and unit costs, with total amount of purchases and credits to be made. If requested, furnish survey data to substantiate quantities.
 - b. Indicate applicable taxes, delivery charges, equipment rental, and amounts of trade discounts.
 - c. Include costs of labor and supervision directly attributable to the change.

- d. Include an updated Contractor's construction schedule that indicates the effect of the change, including, but not limited to, changes in activity duration, start and finish times, and activity relationship. Use available total float before requesting an extension of the Contract Time.
 - e. Quotation Form: Use forms acceptable to Architect.
- B. Contractor-Initiated Proposals: If latent or changed conditions require modifications to the Contract, Contractor may initiate a claim by submitting a request for a change to the Owner.
1. Include a statement outlining reasons for the change and the effect of the change on the Work. Provide a complete description of the proposed change. Indicate the effect of the proposed change on the Contract Sum and the Contract Time.
 2. Include a list of quantities of products required or eliminated and unit costs, with total amount of purchases and credits to be made. If requested, furnish survey data to substantiate quantities.
 3. Indicate applicable taxes, delivery charges, equipment rental, and amounts of trade discounts.
 4. Include costs of labor and supervision directly attributable to the change.
 5. Include an updated Contractor's construction schedule that indicates the effect of the change, including, but not limited to, changes in activity duration, start and finish times, and activity relationship. Use available total float before requesting an extension of the Contract Time.
 6. Comply with requirements in Section 012500 "Substitution Procedures" if the proposed change requires substitution of one product or system for product or system specified.
 7. Proposal Request Form: Use form acceptable to Architect.

1.5 CHANGE ORDER PROCEDURES

- A. On County Representative's approval of a Work Change Proposal Request, the Contractor will issue a Change Order for signatures of Owner and Architect on AIA Document G701.
1. Work Change Proposal Request shall follow the procedure as explained in section G 4e to 4i (County ordered Change of Work) of the **County's General Conditions**. Submit completed Change Proposal Request to the Architect and Owner Representative for review and approval

1.6 CONSTRUCTION CHANGE DIRECTIVE

- A. Construction Change Directive: Architect may issue a Construction Change Directive on AIA Document G714. Construction Change Directive instructs Contractor to proceed with a change in the Work, for subsequent inclusion in a Change Order.
1. Construction Change Directive contains a complete description of change in the Work. It also designates method to be followed to determine change in the Contract Sum or the Contract Time.
- B. Documentation: Maintain detailed records on a time and material basis of work required by the Construction Change Directive.

1. After completion of change, submit an itemized account and supporting data necessary to substantiate cost and time adjustments to the Contract.

PART 2 - PRODUCTS (Not Used)

PART 3 - EXECUTION (Not Used)

END OF SECTION 012600

THIS PAGE INTENSIONALLY LEFT BLANK

Copyright 2015 by The American Institute of Architects (AIA)

SECTION 012900 - PAYMENT PROCEDURES

PART 1 - GENERAL

1.1 RELATED DOCUMENTS

- A. Drawings and general provisions of the Contract, including General and Supplementary Conditions and other Division 01 Specification Sections, apply to this Section.

1.2 SUMMARY

- A. Section includes administrative and procedural requirements necessary to prepare and process Applications for Payment.
- B. Related Requirements:
 - 1. Section 012600 "Contract Modification Procedures" for administrative procedures for handling changes to the Contract.
 - 2. Section 013200 "Construction Progress Documentation" for administrative requirements governing the preparation and submittal of the Contractor's construction schedule.

1.3 DEFINITIONS

- A. Schedule of Values: A statement furnished by Contractor allocating portions of the Contract Sum to various portions of the Work and used as the basis for reviewing Contractor's Applications for Payment.

1.4 SCHEDULE OF VALUES

- A. Coordination: Coordinate preparation of the schedule of values with preparation of Contractor's construction schedule. Cost-loaded Critical Path Method Schedule may serve to satisfy requirements for the schedule of values.
 - 1. Coordinate line items in the schedule of values with items required to be indicated as separate activities in Contractor's construction schedule.
 - 2. Submit the schedule of values to the Project Officer or his representative at earliest possible date, but no later than seven days before the date scheduled for submittal of initial Applications for Payment.
 - 3. Subschedules for Phased Work: Where the Work is separated into phases requiring separately phased payments, provide subschedules showing values coordinated with each phase of payment.

4. Subschedules for Separate Elements of Work: Where the Contractor's construction schedule defines separate elements of the Work, provide subschedules showing values coordinated with each element.
 5. Subschedules for Separate Design Contracts: Where the Owner has retained design professionals under separate contracts who will each provide certification of payment requests, provide subschedules showing values coordinated with the scope of each design services contract, as described in Section 011000 "Summary."
- B. Format and Content: Use Project Manual table of contents as a guide to establish line items for the schedule of values. Provide at least one-line item for each Specification Section.
1. Identification: Include the following Project identification on the schedule of values:
 - a. Project name and location.
 - b. Name of Architect.
 - c. Architect's Project number.
 - d. Contractor's name and address.
 - e. Date of submittal.
 2. Arrange schedule of values consistent with format of AIA Document G703.
 3. Arrange the schedule of values in tabular form, with separate columns to indicate the following for each item listed:
 - a. Related Specification Section or Division.
 - b. Description of the Work.
 - c. Name of subcontractor.
 - d. Name of manufacturer or fabricator.
 - e. Name of supplier.
 - f. Change Orders (numbers) that affect value.
 - g. Dollar value of the following, as a percentage of the Contract Sum to nearest one-hundredth percent, adjusted to total 100 percent. Round dollar amounts to whole dollars, with total equal to Contract Sum.
 - 1) Labor.
 - 2) Materials.
 - 3) Equipment.
 4. Provide a breakdown of the Contract Sum in enough detail to facilitate continued evaluation of Applications for Payment and progress reports. Provide multiple line items for principal subcontract amounts in excess of five percent of the Contract Sum.
 5. Provide a separate line item in the schedule of values for each part of the Work where Applications for Payment may include materials or equipment purchased or fabricated and stored, but not yet installed.
 - a. Differentiate between items stored on-site and items stored off-site.
 6. Purchase Contracts: Provide a separate line item in the schedule of values for each purchase contract. Show line-item value of purchase contract. Indicate Owner payments or deposits, if any, and balance to be paid by Contractor.
 7. Overhead Costs: Include total cost and proportionate share of general overhead and profit for each line item.

8. Closeout Costs. Include separate line items under Contractor and principal subcontracts for Project closeout requirements in an amount totaling five percent of the Contract Sum and subcontract amount.
9. Schedule of Values Revisions: Revise the schedule of values when Change Orders or Construction Change Directives result in a change in the Contract Sum. Include at least one separate line item for each Change Order and Construction Change Directive.

1.5 APPLICATIONS FOR PAYMENT

- A. Each Application for Payment following the initial Application for Payment shall be consistent with previous applications and payments as certified by the Project Officer or designated representative and paid for by Owner.
- B. Payment Application Times: The date for each progress payment is indicated in the Agreement between Owner and Contractor. The period of construction work covered by each Application for Payment is the period indicated in the Agreement.
- C. Application for Payment Forms: Use AIA Document G702 and AIA Document G703 as form for Applications for Payment.
- D. Application Preparation: Complete every entry on form. Notarize and execute by a person authorized to sign legal documents on behalf of Contractor. The Project Officer or designated representative will return incomplete applications without action.
 1. Entries shall match data on the schedule of values and Contractor's construction schedule. Use updated schedules if revisions were made.
 2. Include amounts for work completed following previous Application for Payment, whether or not payment has been received. Include only amounts for work completed at time of Application for Payment.
 3. Include amounts of Change Orders and Construction Change Directives issued before last day of construction period covered by application.
 4. Indicate separate amounts for work being carried out under Owner-requested project acceleration.
- E. Stored Materials: Include in Application for Payment amounts applied for materials or equipment purchased or fabricated and stored, but not yet installed. Differentiate between items stored on-site and items stored off-site.
 1. Provide certificate of insurance, evidence of transfer of title to Owner, and consent of surety to payment for stored materials.
 2. Provide supporting documentation that verifies amount requested, such as paid invoices. Match amount requested with amounts indicated on documentation; do not include overhead and profit on stored materials.
 3. Provide summary documentation for stored materials indicating the following:
 - a. Value of materials previously stored and remaining stored as of date of previous Applications for Payment.
 - b. Value of previously stored materials put in place after date of previous Application for Payment and on or before date of current Application for Payment.

- c. Value of materials stored since date of previous Application for Payment and remaining stored as of date of current Application for Payment.
- F. Transmittal: Submit three signed and notarized original copies of each Application for Payment to Architect by a method ensuring receipt within 24 hours. One copy shall include waivers of lien and similar attachments if required.
1. Transmit each copy with a transmittal form listing attachments and recording appropriate information about application.
- G. Waivers of Mechanic's Lien: With each Application for Payment, submit waivers of mechanic's lien from subcontractors, sub-subcontractors, and suppliers for construction period covered by the previous application.
1. Submit partial waivers on each item for amount requested in previous application, after deduction for retainage, on each item.
 2. When an application shows completion of an item, submit conditional final or full waivers.
 3. Owner reserves the right to designate which entities involved in the Work must submit waivers.
 4. Submit final Application for Payment with or preceded by conditional final waivers from every entity involved with performance of the Work covered by the application who is lawfully entitled to a lien.
 5. Waiver Forms: Submit executed waivers of lien on forms acceptable to Owner.
- H. Initial Application for Payment: Administrative actions and submittals that must precede or coincide with submittal of first Application for Payment include the following:
1. List of subcontractors.
 2. Schedule of values.
 3. Contractor's construction schedule (preliminary if not final).
 4. Products list (preliminary if not final).
 5. Sustainable design action plans, including preliminary project materials cost data.
 6. Schedule of unit prices.
 7. Submittal schedule (preliminary if not final).
 8. List of Contractor's staff assignments.
 9. List of Contractor's principal consultants.
 10. Copies of building permits.
 11. Copies of authorizations and licenses from authorities having jurisdiction for performance of the Work.
 12. Initial progress report.
 13. Report of preconstruction conference.
- I. Application for Payment at Substantial Completion: After Architect issues the Certificate of Substantial Completion, submit an Application for Payment showing 100 percent completion for portion of the Work claimed as substantially complete.
1. Include documentation supporting claim that the Work is substantially complete and a statement showing an accounting of changes to the Contract Sum.
 2. This application shall reflect Certificate(s) of Substantial Completion issued previously for Owner occupancy of designated portions of the Work.

- J. Final Payment Application: After completing Project closeout requirements, submit final Application for Payment with releases and supporting documentation not previously submitted and accepted, including, but not limited, to the following:
1. Evidence of completion of Project closeout requirements.
 2. Insurance certificates for products and completed operations where required and proof that taxes, fees, and similar obligations were paid.
 3. Updated final statement, accounting for final changes to the Contract Sum.
 4. AIA Document G706.
 5. AIA Document G706A.
 6. Evidence that claims have been settled.
 7. Final meter readings for utilities, a measured record of stored fuel, and similar data as of date of Substantial Completion or when Owner took possession of and assumed responsibility for corresponding elements of the Work.
 8. Final liquidated damages settlement statement.

PART 2 - PRODUCTS (Not Used)

PART 3 - EXECUTION (Not Used)

END OF SECTION 012900

THIS PAGE INTENSIONALLY LEFT BLANK

Copyright 2015 by The American Institute of Architects (AIA)

SECTION 013100 - PROJECT MANAGEMENT AND COORDINATION

PART 1 - GENERAL

1.1 RELATED DOCUMENTS

- A. Drawings and general provisions of the Contract, including General and Supplementary Conditions and other Division 01 Specification Sections, apply to this Section.

1.2 SUMMARY

- A. Section includes administrative provisions for coordinating construction operations on Project including, but not limited to, the following:
 - 1. General coordination procedures.
 - 2. Coordination drawings.
 - 3. RFIs.
 - 4. Digital project management procedures.
 - 5. Project meetings.
- B. Related Requirements:
 - 1. Section 013200 "Construction Progress Documentation" for preparing and submitting Contractor's construction schedule.
 - 2. Section 017300 "Execution" for procedures for coordinating general installation and field-engineering services, including establishment of benchmarks and control points.
 - 3. Section 017700 "Closeout Procedures" for coordinating closeout of the Contract.
 - 4. Section 019113 "General Commissioning Requirements" for coordinating the Work with Owner's Commissioning Authority.

1.3 DEFINITIONS

- A. BIM: Building Information Modeling.
- B. RFI: Request for Information. Request from Owner Project Officer, Construction Manager, Architect, or Contractor seeking information required by or clarifications of the Contract Documents.

1.4 INFORMATIONAL SUBMITTALS

- A. Subcontract List: Prepare a written summary identifying individuals or firms proposed for each portion of the Work, including those who are to furnish products or equipment fabricated to a special design. Include the following information in tabular form:

1. Name, address, telephone number, and email address of entity performing subcontract or supplying products.
 2. Number and title of related Specification Section(s) covered by subcontract.
 3. Drawing number and detail references, as appropriate, covered by subcontract.
- B. Key Personnel Names: Within 15 days of starting construction operations, submit a list of key personnel assignments, including superintendent and other personnel in attendance at Project site. Identify individuals and their duties and responsibilities; list addresses and cellular telephone numbers and e-mail addresses. Provide names, addresses, and telephone numbers of individuals assigned as alternates in the absence of individuals assigned to Project.
1. Post copies of list in project meeting room, in temporary field office, in web-based Project software directory, and in prominent location in each built facility. Keep list current at all times.

1.5 GENERAL COORDINATION PROCEDURES

- A. Coordination: Coordinate construction operations included in different Sections of the Specifications to ensure efficient and orderly installation of each part of the Work. Coordinate construction operations included in different Sections that depend on each other for proper installation, connection, and operation.
1. Schedule construction operations in sequence required to obtain the best results where installation of one part of the Work depends on installation of other components, before or after its own installation.
 2. Coordinate installation of different components to ensure maximum performance and accessibility for required maintenance, service, and repair.
 3. Make adequate provisions to accommodate items scheduled for later installation.
 4. The General Contractor shall cooperate with and coordinate work required to be performed by the Owner's independent subcontractors.
- B. Administrative Procedures: Coordinate scheduling and timing of required administrative procedures with other construction activities to avoid conflicts and to ensure orderly progress of the Work. Such administrative activities include, but are not limited to, the following:
1. Preparation of Contractor's construction schedule.
 2. Preparation of the schedule of values.
 3. Installation and removal of temporary facilities and controls.
 4. Delivery and processing of submittals.
 5. Progress meetings.
 6. Preinstallation conferences.
 7. Project closeout activities.
 8. Startup and adjustment of systems.

1.6 COORDINATION DRAWINGS

- A. Coordination Drawings, General: Prepare coordination drawings according to requirements in individual Sections, and additionally where installation is not completely indicated on Shop Drawings, where limited space availability necessitates coordination, or if coordination is

required to facilitate integration of products and materials fabricated or installed by more than one entity.

1. Content: Project-specific information, drawn accurately to a scale large enough to indicate and resolve conflicts. Do not base coordination drawings on standard printed data. Include the following information, as applicable:
 - a. Use applicable Drawings as a basis for preparation of coordination drawings. Prepare sections, elevations, and details as needed to describe relationship of various systems and components.
 - b. Coordinate the addition of trade-specific information to coordination drawings by multiple contractors in a sequence that best provides for coordination of the information and resolution of conflicts between installed components before submitting for review.
 - c. Indicate functional and spatial relationships of components of architectural, structural, civil, mechanical, and electrical systems.
 - d. Indicate space requirements for routine maintenance and for anticipated replacement of components during the life of the installation.
 - e. Show location and size of access doors required for access to concealed dampers, valves, and other controls.
 - f. Indicate required installation sequences.
 - g. Indicate dimensions shown on Drawings. Specifically note dimensions that appear to be in conflict with submitted equipment and minimum clearance requirements. Provide alternative sketches to Architect indicating proposed resolution of such conflicts. Minor dimension changes and difficult installations will not be considered changes to the Contract.

B. Coordination Drawing Organization: Organize coordination drawings as follows:

1. Floor Plans and Reflected Ceiling Plans: Show architectural and structural elements, and mechanical, plumbing, fire-protection, fire-alarm, and electrical Work. Show locations of visible ceiling-mounted devices relative to acoustical ceiling grid. Supplement plan drawings with section drawings where required to adequately represent the Work.
2. Plenum Space: Indicate subframing for support of ceiling, raised access floor, and wall systems, mechanical and electrical equipment, and related Work. Locate components within plenums to accommodate layout of light fixtures and other components indicated on Drawings. Indicate areas of conflict between light fixtures and other components.
3. Mechanical Rooms: Provide coordination drawings for mechanical rooms showing plans and elevations of mechanical, plumbing, fire-protection, fire-alarm, and electrical equipment.
4. Structural Penetrations: Indicate penetrations and openings required for all disciplines.
5. Slab Edge and Embedded Items: Indicate slab edge locations and sizes and locations of embedded items for metal fabrications, sleeves, anchor bolts, bearing plates, angles, door floor closers, slab depressions for floor finishes, curbs and housekeeping pads, and similar items.
6. Mechanical and Plumbing Work: Show the following:
 - a. Sizes and bottom elevations of ductwork, piping, and conduit runs, including insulation, bracing, flanges, and support systems.
 - b. Dimensions of major components, such as dampers, valves, diffusers, access doors, cleanouts and electrical distribution equipment.

- c. Fire-rated enclosures around ductwork.
 7. Electrical Work: Show the following:
 - a. Runs of vertical and horizontal conduit 1-1/4 inches (32 mm) in diameter and larger.
 - b. Light fixture, exit light, emergency battery pack, smoke detector, and other fire-alarm locations.
 - c. Panel board, switch board, switchgear, transformer, busway, generator, and motor-control center locations.
 - d. Location of pull boxes and junction boxes, dimensioned from column center lines.
 8. Fire-Protection System: Show the following:
 - a. Locations of standpipes, mains piping, branch lines, pipe drops, and sprinkler heads.
 9. Review: Architect will review coordination drawings to confirm that in general the Work is being coordinated, but not for the details of the coordination, which are Contractor's responsibility. If Architect determines that coordination drawings are not being prepared in sufficient scope or detail, or are otherwise deficient, Architect will so inform Contractor, who shall make suitable modifications and resubmit.
 10. Coordination Drawing PDFs: Prepare coordination drawing PDFs according to requirements in Section 013300 "Submittal Procedures."
 - C. Coordination Digital Data Files: Prepare coordination digital data files according to the following requirements:
 1. File Preparation Format: Same digital data software program, version, and operating system as original Drawings.
 2. File Submittal Format: Submit or post coordination drawing files using PDF format.
 3. Architect may furnish Contractor one limited set of digital data files of Drawings for use in preparing coordination digital data files at the direction of the Owner Project Officer.
 - a. Architect makes no representations as to the accuracy or completeness of digital data files as they relate to Drawings.
 - b. Digital Data Software Program: Drawings are available in Autocad 2017.
 - c. Contractor shall execute a data licensing agreement in the form of Agreement form acceptable to Owner Project Officer and Architect.
- 1.7 REQUEST FOR INFORMATION (RFI)
- A. General: Immediately on discovery of the need for additional information, clarification, or interpretation of the Contract Documents, Contractor shall prepare and submit an RFI in the form specified.
 1. The Project Officer will return without response those RFIs submitted to Architect by other entities controlled by Contractor.

2. Coordinate and submit RFIs in a prompt manner so as to avoid delays in Contractor's work or work of subcontractors.
- B. Content of the RFI: Include a detailed, legible description of item needing information or interpretation and the following:
1. Project name.
 2. Project number.
 3. Date.
 4. Name of Contractor.
 5. Name of Architect.
 6. RFI number, numbered sequentially.
 7. RFI subject.
 8. Specification Section number and title and related paragraphs, as appropriate.
 9. Drawing number and detail references, as appropriate.
 10. Field dimensions and conditions, as appropriate.
 11. Contractor's suggested resolution. If Contractor's suggested resolution impacts the Contract Time or the Contract Sum, Contractor shall state impact in the RFI.
 12. Contractor's signature.
 13. Attachments: Include sketches, descriptions, measurements, photos, Product Data, Shop Drawings, coordination drawings, and other information necessary to fully describe items needing interpretation.
 - a. Include dimensions, thicknesses, structural grid references, and details of affected materials, assemblies, and attachments on attached sketches.
- C. RFI Forms: AIA Document G716 or Software-generated form with substantially the same content as indicated above, acceptable to Architect.
1. Attachments shall be electronic files in PDF format.
- D. Architect's Action: Architect will review each RFI, determine action required, and respond. Allow seven working days for Architect's response for each RFI. RFIs received by Architect after 1:00 p.m. will be considered as received the following working day.
1. The following Contractor-generated RFIs will be returned without action:
 - a. Requests for approval of submittals.
 - b. Requests for approval of substitutions.
 - c. Requests for approval of Contractor's means and methods.
 - d. Requests for coordination information already indicated in the Contract Documents.
 - e. Requests for adjustments in the Contract Time or the Contract Sum.
 - f. Requests for interpretation of Architect's actions on submittals.
 - g. Incomplete RFIs or inaccurately prepared RFIs.
 2. Architect's action may include a request for additional information, in which case Architect's time for response will date from time of receipt by Architect of additional information.

3. Architect's action on RFIs that may result in a change to the Contract Time or the Contract Sum may be eligible for Contractor to submit Change Proposal according to Section 012600 "Contract Modification Procedures."
 - a. If Contractor believes the RFI response warrants change in the Contract Time or the Contract Sum, notify Architect in writing within 10 days of receipt of the RFI response.
- E. RFI Log: Prepare, maintain, and submit a tabular log of RFIs organized by the RFI number. Submit log submitted at each coordination bi-weekly coordination meeting. Use software log that is part of web-based Project software log with not less than the following:
 1. Project name.
 2. Name and address of Contractor.
 3. Name and address of Architect.
 4. RFI number including RFIs that were returned without action or withdrawn.
 5. RFI description.
 6. Date the RFI was submitted.
 7. Date Architect's response was received.
 8. Identification of related Minor Change in the Work, Construction Change Directive, and Proposal Request, as appropriate.
- F. On receipt of Architect's action, update the RFI log and immediately distribute the RFI response to affected parties. Review response and notify Architect within seven days if Contractor disagrees with response.

1.8 DIGITAL PROJECT MANAGEMENT PROCEDURES

- A. Use of Architect's Digital Data Files: Digital data files of Architect's limited CAD drawings will be provided by Architect for Contractor's use during construction.
 1. Digital data files may be used by Contractor in preparing coordination drawings, Shop Drawings, and Project record Drawings.
 2. Architect makes no representations as to the accuracy or completeness of digital data files as they relate to Contract Drawings.
 3. Digital Drawing Software Program: Contract Drawings are available in Autocad 2017.
 4. Contractor shall execute a data licensing agreement in the form of AIA Document C106 Digital Data Licensing Agreement.
 - a. Subcontractors, and other parties granted access by Contractor to Architect's digital data files shall execute a data licensing agreement in the form of AIA Document C106.
 5. The following digital data files will be furnished for each appropriate discipline:
 - a. Floor plans.
 - b. Reflected ceiling plans.
- B. Web-Based Project Software: The Project and all participants will use the **Contractor's** web-based Project software site for purposes of hosting and managing Project communication and documentation until Final Completion.

1. Web-based Project software site includes, at a minimum, the following features:
 - a. Compilation of Project data, including Contractor, subcontractors, Architect, architect's consultants, Owner Project Officer, and other entities involved in Project. Include names of individuals and contact information.
 - b. Access control for each entity for each workflow process, to determine entity's digital rights to create, modify, view, and print documents.
 - c. Document workflow planning, allowing customization of workflow between project entities.
 - d. Creation, logging, tracking, and notification for Project communications required in other Specification Sections, including, but not limited to, RFIs, submittals, Minor Changes in the Work, Construction Change Directives, and Change Orders.
 - e. Track status of each Project communication in real time, and log time and date when responses are provided.
 - f. Procedures for handling PDFs or similar file formats, allowing markups by each entity. Provide security features to lock markups against changes once submitted.
 - g. Processing and tracking of payment applications.
 - h. Processing and tracking of contract modifications.
 - i. Creating and distributing meeting minutes.
 - j. Document management for Drawings, Specifications, and coordination drawings, including revision control.
 - k. Management of construction progress photographs.
 - l. Mobile device compatibility, including smartphones and tablets.
 - m. Revit/3d Model integration into the required/marked up digital set
 - n. Dashboard tracking of RFI's, Submittals, Punchlist, etc..
 2. Provide up to 8 web-based Project software user licenses for use of Owner Project Officer, Owner's Commissioning Authority, Architect, and Architect's consultants. Provide eight hours of online software training for web-based Project software users.
 3. At completion of Project, provide digital archive in format that is readable by common desktop software applications in format acceptable to Architect. Provide data in locked format to prevent further changes.
 4. Provide one of the following web-based Project software packages under their current published licensing agreements:
 - a. Primavera Submittal Exchange (Basis of Design)
 - b. Or equal, must submit for approval
- C. PDF Document Preparation: Where PDFs are required to be submitted to Architect, prepare as follows:
1. Assemble complete submittal package into a single indexed file incorporating submittal requirements of a single Specification Section and transmittal form with links enabling navigation to each item.
 2. Name file with submittal number or other unique identifier, including revision identifier.
 3. Certifications: Where digitally submitted certificates and certifications are required, provide a digital signature with digital certificate on where indicated.

1.9 PROJECT MEETINGS

- A. General: Schedule and conduct meetings and conferences at Project site unless otherwise indicated.
1. Attendees: Inform participants and others involved, and individuals whose presence is required, of date and time of each meeting. Notify Owner Project Officer and Architect of scheduled meeting dates and times a minimum of 10 working days prior to meeting.
 2. Agenda: Prepare the meeting agenda. Distribute the agenda to all invited attendees.
 3. Minutes: Entity responsible for conducting meeting will record significant discussions and agreements achieved. Distribute the meeting minutes to everyone concerned, including Owner Project Officer and Architect, within three days of the meeting.
- B. Preconstruction Conference: The County will schedule and conduct a preconstruction conference before starting construction, at a time convenient to Contractor and Architect, but no later than 15 days after execution of the Agreement.
1. Attendees: Authorized representatives of Owner Project Officer, Owner's Commissioning Authority, Architect, and their consultants; Contractor and its superintendent; major subcontractors; suppliers; and other concerned parties shall attend the conference. Participants at the conference shall be familiar with Project and authorized to conclude matters relating to the Work.
 2. Agenda: Discuss items of significance that could affect progress, including the following:
 - a. Responsibilities and personnel assignments.
 - b. Tentative construction schedule.
 - c. Phasing.
 - d. Critical work sequencing and long lead items.
 - e. Designation of key personnel and their duties.
 - f. Lines of communications.
 - g. Use of web-based Project software.
 - h. Procedures for processing field decisions and Change Orders.
 - i. Procedures for RFIs.
 - j. Procedures for testing and inspecting.
 - k. Procedures for processing Applications for Payment.
 - l. Distribution of the Contract Documents.
 - m. Submittal procedures.
 - n. Sustainable design requirements.
 - o. Preparation of Record Documents.
 - p. Use of the premises and existing building.
 - q. Work restrictions.
 - r. Working hours.
 - s. The County's Separate Contractors.
 - t. Responsibility for temporary facilities and controls.
 - u. Procedures for moisture and mold control.
 - v. Procedures for disruptions and shutdowns.
 - w. Construction waste management and recycling.
 - x. Parking availability.
 - y. Office, work, and storage areas.
 - z. Equipment deliveries and priorities.
 - aa. First aid.

- bb. Security.
 - cc. Progress cleaning.
3. Minutes: Entity responsible for conducting meeting will record and distribute meeting minutes.
- C. Sustainable Design Requirements Coordination Conference: A “Technical Adviser Kick-off Meeting” shall be scheduled with the Owner Project Officer, Contractor, Architect, and Viridian (as outlined in section 018113-63) prior to the start of construction. .
- 1. Attendees: Authorized representatives of Owner Project Officer, Owner's Commissioning Authority, Architect, and their consultants; Contractor and its superintendent and sustainable design coordinator; major subcontractors; suppliers; and other concerned parties shall attend the conference. Participants at the conference shall be familiar with Project and authorized to conclude matters relating to the Work.
 - 2. Agenda: Discuss items of significance that could affect meeting sustainable design requirements, including the following:
 - a. Sustainable design Project checklist.
 - b. General requirements for sustainable design-related procurement and documentation.
 - c. Project closeout requirements and sustainable design certification procedures.
 - d. Role of sustainable design coordinator.
 - e. Construction waste management.
 - f. Construction operations and sustainable design requirements and restrictions.
 - 3. Minutes: Entity responsible for conducting meeting will record and distribute meeting minutes.
- D. Preinstallation Conferences: General Contractor will onduct a preinstallation conference at Project site before each construction activity when required by other sections and when required for coordination with other construction.
- 1. Attendees: Installer and representatives of manufacturers and fabricators involved in or affected by the installation and its coordination or integration with other materials and installations that have preceded or will follow, shall attend the meeting. Advise Architect, and Owner's Commissioning Authority of scheduled meeting dates.
 - 2. Agenda: Review progress of other construction activities and preparations for the particular activity under consideration, including requirements for the following:
 - a. Contract Documents.
 - b. Options.
 - c. Related RFIs.
 - d. Related Change Orders.
 - e. Purchases.
 - f. Deliveries.
 - g. Submittals.
 - h. Sustainable design requirements.
 - i. Review of mockups.
 - j. Possible conflicts.
 - k. Compatibility requirements.

- l. Time schedules.
 - m. Weather limitations.
 - n. Manufacturer's written instructions.
 - o. Warranty requirements.
 - p. Compatibility of materials.
 - q. Acceptability of substrates.
 - r. Temporary facilities and controls.
 - s. Space and access limitations.
 - t. Regulations of authorities having jurisdiction.
 - u. Testing and inspecting requirements.
 - v. Installation procedures.
 - w. Coordination with other work.
 - x. Required performance results.
 - y. Protection of adjacent work.
 - z. Protection of construction and personnel.
3. Record significant conference discussions, agreements, and disagreements, including required corrective measures and actions.
 4. Reporting: Distribute minutes of the meeting to each party present and to other parties requiring information.
 5. Do not proceed with installation if the conference cannot be successfully concluded. Initiate whatever actions are necessary to resolve impediments to performance of the Work and reconvene the conference at earliest feasible date.
- E. Project Closeout Conference: The General Contractor will schedule and conduct a project closeout conference, at a time convenient to Owner Project Officer and Architect, but no later than 90 days prior to the scheduled date of Substantial Completion.
1. Conduct the conference to review requirements and responsibilities related to Project closeout.
 2. Attendees: Authorized representatives of Owner Project Officer, Owner's Commissioning Authority, Architect, and their consultants; Contractor and its superintendent; major subcontractors; suppliers; and other concerned parties shall attend the meeting. Participants at the meeting shall be familiar with Project and authorized to conclude matters relating to the Work.
 3. Agenda: Discuss items of significance that could affect or delay Project closeout, including the following:
 - a. Preparation of Record Documents.
 - b. Procedures required prior to inspection for Substantial Completion and for final inspection for acceptance.
 - c. Procedures for completing and archiving web-based Project software site data files.
 - d. Submittal of written warranties.
 - e. Requirements for completing sustainable design documentation.
 - f. Requirements for preparing operations and maintenance data.
 - g. Requirements for delivery of material samples, attic stock, and spare parts.
 - h. Requirements for demonstration and training.
 - i. Preparation of Contractor's punch list.
 - j. Procedures for processing Applications for Payment at Substantial Completion and for final payment.

- k. Submittal procedures.
 - l. Attic stocks requirements.
 - m. Installation of Owner's furniture, fixtures, and equipment.
 - n. Responsibility for removing temporary facilities and controls.
4. Minutes: Entity conducting meeting will record and distribute meeting minutes.
- F. Progress Meetings: The General Contractor will conduct progress meetings at biweekly intervals. Progress meeting frequency can be adjusted with the Project Officers approval.
1. Coordinate dates of meetings with preparation of payment requests.
 2. Attendees: In addition to representatives of Owner Project Officer, Owner's Commissioning Authority and Architect, each contractor, subcontractor, supplier, and other entity concerned with current progress or involved in planning, coordination, or performance of future activities shall be represented at these meetings. All participants at the meeting shall be familiar with Project and authorized to conclude matters relating to the Work.
 3. Agenda: Review and correct or approve minutes of previous progress meeting. Review other items of significance that could affect progress. Include topics for discussion as appropriate to status of Project.
 - a. Contractor's Construction Schedule: Review progress since the last meeting. Determine whether each activity is on time, ahead of schedule, or behind schedule, in relation to Contractor's construction schedule. Determine how construction behind schedule will be expedited; secure commitments from parties involved to do so. Discuss whether schedule revisions are required to ensure that current and subsequent activities will be completed within the Contract Time.
 - 1) Review schedule for next period.
 - b. Review present and future needs of each entity present, including the following:
 - 1) Interface requirements.
 - 2) Sequence of operations.
 - 3) Status of submittals.
 - 4) Status of sustainable design documentation.
 - 5) Deliveries.
 - 6) Off-site fabrication.
 - 7) Access.
 - 8) Site use.
 - 9) Temporary facilities and controls.
 - 10) Progress cleaning.
 - 11) Quality and work standards.
 - 12) Status of correction of deficient items.
 - 13) Field observations.
 - 14) Status of RFIs.
 - 15) Status of Proposal Requests.
 - 16) Pending changes.
 - 17) Status of Change Orders.
 - 18) Pending claims and disputes.
 - 19) Documentation of information for payment requests.

4. Minutes: The General Contractor shall be responsible for conducting the meeting, recording and distributing the meeting minutes to each party present and to parties requiring information.
 - a. Schedule Updating: Revise Contractor's construction schedule after each progress meeting where revisions to the schedule have been made or recognized. Issue revised schedule concurrently with the report of each meeting.

PART 2 - PRODUCTS (Not Used)

PART 3 - EXECUTION (Not Used)

END OF SECTION 013100

Copyright 2015 by The American Institute of Architects (AIA)

SECTION 013200 - CONSTRUCTION PROGRESS DOCUMENTATION

PART 1 - GENERAL

1.1 RELATED DOCUMENTS

- A. Drawings and general provisions of the Contract, including General and Supplementary Conditions and other Division 01 Specification Sections, apply to this Section.

1.2 SUMMARY

- A. Section includes administrative and procedural requirements for documenting the progress of construction during performance of the Work, including the following:
 - 1. Startup construction schedule.
 - 2. Contractor's Construction Schedule.
 - 3. Construction schedule updating reports.
 - 4. Weekly construction reports.
 - 5. Material location reports.
 - 6. Site condition reports.
 - 7. Unusual event reports.

1.3 DEFINITIONS

- A. Activity: A discrete part of a project that can be identified for planning, scheduling, monitoring, and controlling the construction Project. Activities included in a construction schedule consume time and resources.
 - 1. Critical Activity: An activity on the critical path that must start and finish on the planned early start and finish times.
 - 2. Predecessor Activity: An activity that precedes another activity in the network.
 - 3. Successor Activity: An activity that follows another activity in the network.
- B. Cost Loading: The allocation of the schedule of values for completing an activity as scheduled. The sum of costs for all activities must equal the total Contract Sum.
- C. CPM: Critical path method, which is a method of planning and scheduling a construction project where activities are arranged based on activity relationships. Network calculations determine when activities can be performed and the critical path of Project.
- D. Critical Path: The longest connected chain of interdependent activities through the network schedule that establishes the minimum overall Project duration and contains no float.
- E. Event: The starting or ending point of an activity.

- F. Float: The measure of leeway in starting and completing an activity.
 - 1. Float time belongs to Owner.
 - 2. Free float is the amount of time an activity can be delayed without adversely affecting the early start of the successor activity.
 - 3. Total float is the measure of leeway in starting or completing an activity without adversely affecting the planned Project completion date.
- G. Resource Loading: The allocation of manpower and equipment necessary for completing an activity as scheduled.

1.4 INFORMATIONAL SUBMITTALS

- A. Format for Submittals: Submit required submittals in the following format:
 - 1. Working electronic copy of schedule file, where indicated.
 - 2. PDF file.
- B. Startup construction schedule.
 - 1. Submittal of cost-loaded, startup construction schedule will not constitute approval of schedule of values for cost-loaded activities.
- C. Startup Network Diagram: Of size required to display entire network for entire construction period. Show logic ties for activities.
- D. Contractor's Construction Schedule: Initial schedule, of size required to display entire schedule for entire construction period.
 - 1. Submit a working digital copy of schedule, using software indicated, and labeled to comply with requirements for submittals.
- E. CPM Reports: Concurrent with CPM schedule, submit each of the following reports. Format for each activity in reports shall contain activity number, activity description, cost and resource loading, original duration, remaining duration, early start date, early finish date, late start date, late finish date, and total float in calendar days.
 - 1. Activity Report: List of activities sorted by activity number and then early start date, or actual start date if known.
 - 2. Logic Report: List of preceding and succeeding activities for each activity, sorted in ascending order by activity number and then by early start date, or actual start date if known.
 - 3. Total Float Report: List of activities sorted in ascending order of total float.
 - 4. Earnings Report: Compilation of Contractor's total earnings from commencement of the Work until most recent Application for Payment.
- F. Construction Schedule Updating Reports: Submit with Applications for Payment. The General Contractor shall prepare and distribute a 'two-week' look ahead Gantt schedule at each progress meeting. The 'look-ahead' schedule shall be in a format acceptable to the A/E and represent the

GC and sub-contractors work plans for construction activities to occur the following two week period. Construction activities shall reference activities defined on the Construction Schedule.

- G. Weekly Construction Reports: Submit at Bi-Weekly intervals.
- H. Material Location Reports: Submit at monthly intervals.
- I. Site Condition Reports: Submit at time of discovery of differing conditions.
- J. Unusual Event Reports: Submit at time of unusual event.
- K. Qualification Data: For scheduling consultant.

1.5 QUALITY ASSURANCE

- A. Scheduling Consultant Qualifications: An experienced specialist in CPM scheduling and reporting, with capability of producing CPM reports and diagrams within 24 hours of Architect's request.
- B. Prescheduling Conference: Conduct conference at Project site to comply with requirements in Section 013100 "Project Management and Coordination." Review methods and procedures related to the preliminary construction schedule and Contractor's Construction Schedule, including, but not limited to, the following:
 - 1. Review software limitations and content and format for reports.
 - 2. Verify availability of qualified personnel needed to develop and update schedule.
 - 3. Discuss constraints, including phasing work stages area separations interim milestones and partial Owner occupancy.
 - 4. Review delivery dates for Owner-furnished products.
 - 5. Review schedule for work of Owner's separate contracts.
 - 6. Review submittal requirements and procedures.
 - 7. Review time required for review of submittals and resubmittals.
 - 8. Review requirements for tests and inspections by independent testing and inspecting agencies.
 - 9. Review time required for Project closeout and Owner startup procedures, including commissioning activities.
 - 10. Review and finalize list of construction activities to be included in schedule.
 - 11. Review procedures for updating schedule.

1.6 COORDINATION

- A. Coordinate Contractor's Construction Schedule with the schedule of values, list of subcontracts, submittal schedule, progress reports, payment requests, and other required schedules and reports.
 - 1. Secure time commitments for performing critical elements of the Work from entities involved.
 - 2. Coordinate each construction activity in the network with other activities and schedule them in proper sequence.

1.7 CONTRACTOR'S CONSTRUCTION SCHEDULE, GENERAL

- A. Computer Scheduling Software: Prepare schedules using current version of a program that has been developed specifically to manage construction schedules.
1. Use Software package acceptable to the Owner Project Officer and Architect for current Windows operating system.
- B. Time Frame: Extend schedule from date established for the Notice of Award to date of final completion.
1. Contract completion date shall not be changed by submission of a schedule that shows an early completion date, unless specifically authorized by Change Order.
- C. Activities: Treat each floor or separate area as a separate numbered activity for each main element of the Work. Comply with the following:
1. Activity Duration: Define activities so no activity is longer than 20 days, unless specifically allowed by Architect.
 2. Procurement Activities: Include procurement process activities for the following long lead items and major items, requiring a cycle of more than 60 days, as separate activities in schedule. Procurement cycle activities include, but are not limited to, submittals, approvals, purchasing, fabrication, and delivery. Long lead items to include but not limited to the following:
 - a. Elevator
 - b. Mechanical Equipment
 3. Submittal Review Time: Include review and resubmittal times indicated in Section 013300 "Submittal Procedures" in schedule. Coordinate submittal review times in Contractor's Construction Schedule with submittal schedule.
 4. Startup and Testing Time: Include no fewer than 15 days for startup and testing.
 5. Commissioning Time: Include no fewer than 15 days for commissioning.
 6. Substantial Completion: Indicate completion in advance of date established for Substantial Completion and allow time for Architect's administrative procedures necessary for certification of Substantial Completion.
 7. Punch List and Final Completion: Include not more than 30 days for completion of punch list items and final completion.
- D. Constraints: Include constraints and work restrictions indicated in the Contract Documents and as follows in schedule and show how the sequence of the Work is affected.
1. Phasing: Arrange list of activities on schedule by phase.
 2. Work by Owner: Include a separate activity for each portion of the Work performed by Owner.
 3. Products Ordered in Advance: Include a separate activity for each product. Include delivery date indicated in Section 011000 "Summary." Delivery dates indicated stipulate the earliest possible delivery date.
 4. Owner-Furnished Products: Include a separate activity for each product. Include delivery date indicated in Section 011000 "Summary." Delivery dates indicated stipulate the earliest possible delivery date.

5. Work Restrictions: Show the effect of the following items on the schedule:
 - a. Seasonal variations.
 - b. Environmental control.

6. Work Stages: Indicate important stages of construction for each major portion of the Work, including, but not limited to, the following:
 - a. Subcontract awards.
 - b. Submittals.
 - c. Purchases.
 - d. Mockups.
 - e. Fabrication.
 - f. Sample testing.
 - g. Deliveries.
 - h. Installation.
 - i. Tests and inspections.
 - j. Adjusting.
 - k. Curing.
 - l. Building flush-out.
 - m. Startup and placement into final use and operation.
 - n. Commissioning.

7. Construction Areas: Identify each major area of construction for each major portion of the Work. Indicate where each construction activity within a major area must be sequenced or integrated with other construction activities to provide for the following:
 - a. Structural completion.
 - b. Permanent space enclosure.
 - c. Completion of mechanical installation.
 - d. Completion of electrical installation.
 - e. Substantial Completion.

- E. Milestones: Include milestones indicated in the Contract Documents in schedule, including, but not limited to, the Notice to Proceed, Substantial Completion, and final completion.

- F. Cost Correlation: Superimpose a cost correlation timeline, indicating planned and actual costs. On the line, show planned and actual dollar volume of the Work performed as of planned and actual dates used for preparation of payment requests.
 1. See Section 012900 "Payment Procedures" for cost reporting and payment procedures.

- G. Upcoming Work Summary: Prepare summary report indicating activities scheduled to occur or commence prior to submittal of next schedule update. Summarize the following issues:
 1. Unresolved issues.
 2. Unanswered Requests for Information.
 3. Rejected or unreturned submittals.
 4. Notations on returned submittals.
 5. Pending modifications affecting the Work and the Contract Time.

- H. Contractor's Construction Schedule Updating: At monthly intervals, update schedule to reflect actual construction progress and activities. Issue schedule one week before each regularly scheduled progress meeting.
 - 1. Revise schedule immediately after each meeting or other activity where revisions have been recognized or made. Issue updated schedule concurrently with the report of each such meeting.
 - 2. Include a report with updated schedule that indicates every change, including, but not limited to, changes in logic, durations, actual starts and finishes, and activity durations.
 - 3. As the Work progresses, indicate final completion percentage for each activity.
- I. Recovery Schedule: When periodic update indicates the Work is 14 or more calendar days behind the current approved schedule, submit a separate recovery schedule indicating means by which Contractor intends to regain compliance with the schedule. Indicate changes to working hours, working days, crew sizes, equipment required to achieve compliance, and date by which recovery will be accomplished.
- J. Distribution: Distribute copies of approved schedule to Architect, Owner, Project Officer, separate contractors, testing and inspecting agencies, and other parties identified by Contractor with a need-to-know schedule responsibility.
 - 1. Post copies in Project meeting rooms and temporary field offices.
 - 2. When revisions are made, distribute updated schedules to the same parties and post in the same locations. Delete parties from distribution when they have completed their assigned portion of the Work and are no longer involved in performance of construction activities.

1.8 STARTUP CONSTRUCTION SCHEDULE

- A. Gantt-Chart Schedule: Submit startup, horizontal, Gantt-chart-type construction schedule within seven days of date established for the Notice of Award.
- B. Preparation: Indicate each significant construction activity separately. Identify first workday of each week with a continuous vertical line. Outline significant construction activities for first 90 days of construction. Include skeleton diagram for the remainder of the Work and a cash requirement prediction based on indicated activities.

1.9 GANTT-CHART SCHEDULE REQUIREMENTS

- A. Gantt-Chart Schedule: Submit a comprehensive, fully developed, horizontal, Gantt-chart-type, Contractor's Construction Schedule within 30 days of date established for the Notice of Award.
 - 1. Base schedule on the startup construction schedule and additional information received since the start of Project.
- B. Preparation: Indicate each significant construction activity separately. Identify first workday of each week with a continuous vertical line.
 - 1. For construction activities that require three months or longer to complete, indicate an estimated completion percentage in 10 percent increments within time bar.

1.10 CPM SCHEDULE REQUIREMENTS

- A. General: Prepare network diagrams using AON (activity-on-node) format.
- B. Startup Network Diagram: Submit diagram within 14 days of date established for the Notice of Award. Outline significant construction activities for the first 90 days of construction. Include skeleton diagram for the remainder of the Work and a cash requirement prediction based on indicated activities.
- C. CPM Schedule: Prepare Contractor's Construction Schedule using a cost- and resource-loaded, time-scaled CPM network analysis diagram for the Work.
 - 1. Develop network diagram in sufficient time to submit CPM schedule so it can be accepted for use no later than 60 days after date established for **the Notice to Proceed**.
 - a. Failure to include any work item required for performance of this Contract shall not excuse Contractor from completing all work within applicable completion dates.
 - 2. Establish procedures for monitoring and updating CPM schedule and for reporting progress. Coordinate procedures with progress meeting and payment request dates.
 - 3. Use "one workday" as the unit of time for individual activities. Indicate nonworking days and holidays incorporated into the schedule to coordinate with the Contract Time.
- D. CPM Schedule Preparation: Prepare a list of all activities required to complete the Work. Using the startup network diagram, prepare a skeleton network to identify probable critical paths.
 - 1. Activities: Indicate the estimated time duration, sequence requirements, and relationship of each activity in relation to other activities. Include estimated time frames for the following activities:
 - a. Preparation and processing of submittals.
 - b. Mobilization and demobilization.
 - c. Purchase of materials.
 - d. Delivery.
 - e. Fabrication.
 - f. Utility interruptions.
 - g. Installation.
 - h. Work by Owner that may affect or be affected by Contractor's activities.
 - i. Testing and inspection.
 - j. Commissioning.
 - k. Punch list and final completion.
 - l. Activities occurring following final completion.
 - 2. Critical Path Activities: Identify critical path activities, including those for interim completion dates. Scheduled start and completion dates shall be consistent with Contract milestone dates.
 - 3. Processing: Process data to produce output data on a computer-drawn, time-scaled network. Revise data, reorganize activity sequences, and reproduce as often as necessary to produce the CPM schedule within the limitations of the Contract Time.
 - 4. Format: Mark the critical path. Locate the critical path near center of network; locate paths with most float near the edges.

- a. Subnetworks on separate sheets are permissible for activities clearly off the critical path.
5. Cost- and Resource-Loading of CPM Schedule: Assign cost to construction activities on the CPM schedule. Do not assign costs to submittal activities. Obtain Architect's approval prior to assigning costs to fabrication and delivery activities. Assign costs under main subcontracts for testing and commissioning activities, operation and maintenance manuals, punch list activities, Project record documents, and demonstration and training (if applicable), in the amount of percent of the Contract Sum.
 - a. Each activity cost shall reflect an appropriate value subject to approval by Architect.
 - b. Total cost assigned to activities shall equal the total Contract Sum.
- E. Contract Modifications: For each proposed contract modification and concurrent with its submission, prepare a time-impact analysis using a network fragment to demonstrate the effect of the proposed change on the overall Project schedule.
- F. Initial Issue of Schedule: Prepare initial network diagram from a sorted activity list indicating straight "early start-total float." Identify critical activities. Prepare tabulated reports showing the following:
1. Contractor or subcontractor and the Work or activity.
 2. Description of activity.
 3. Main events of activity.
 4. Immediate preceding and succeeding activities.
 5. Early and late start dates.
 6. Early and late finish dates.
 7. Activity duration in workdays.
 8. Total float or slack time.
 9. Average size of workforce.
 10. Dollar value of activity (coordinated with the schedule of values).
- G. Schedule Updating: Concurrent with making revisions to schedule, prepare tabulated reports showing the following:
1. Identification of activities that have changed.
 2. Changes in early and late start dates.
 3. Changes in early and late finish dates.
 4. Changes in activity durations in workdays.
 5. Changes in the critical path.
 6. Changes in total float or slack time.
 7. Changes in the Contract Time.
- H. Value Summaries: Prepare two cumulative value lists, sorted by finish dates.
1. In first list, tabulate activity number, early finish date, dollar value, and cumulative dollar value.
 2. In second list, tabulate activity number, late finish date, dollar value, and cumulative dollar value.

3. In subsequent issues of both lists, substitute actual finish dates for activities completed as of list date.
4. Prepare list for ease of comparison with payment requests; coordinate timing with progress meetings.
 - a. In both value summary lists, tabulate "actual percent complete" and "cumulative value completed" with total at bottom.
 - b. Submit value summary printouts one week before each regularly scheduled progress meeting.

1.11 REPORTS

- A. Daily Construction Reports: Prepare a daily construction report recording the following information concerning events at Project site:
 1. List of subcontractors at Project site.
 2. List of separate contractors at Project site.
 3. Approximate count of personnel at Project site.
 4. Equipment at Project site.
 5. Material deliveries.
 6. High and low temperatures and general weather conditions, including presence of rain or snow.
 7. Testing and inspection.
 8. Accidents.
 9. Meetings and significant decisions.
 10. Stoppages, delays, shortages, and losses.
 11. Orders and requests of authorities having jurisdiction.
 12. Change Orders received and implemented.
 13. Construction Change Directives received and implemented.
 14. Services connected and disconnected.
 15. Equipment or system tests and startups.
 16. Partial completions and occupancies.
 17. Substantial Completions authorized.
- B. Material Location Reports: At weekly intervals, prepare and submit a comprehensive list of materials delivered to and stored at Project site. List shall be cumulative, showing materials previously reported plus items recently delivered. Include with list a statement of progress on and delivery dates for materials or items of equipment fabricated or stored away from Project site. Indicate the following categories for stored materials:
 1. Material stored prior to previous report and remaining in storage.
 2. Material stored prior to previous report and since removed from storage and installed.
 3. Material stored following previous report and remaining in storage.
- C. Site Condition Reports: Immediately on discovery of a difference between site conditions and the Contract Documents, prepare and submit a detailed report. Submit with a Request for Information. Include a detailed description of the differing conditions, together with recommendations for changing the Contract Documents.

- D. Unusual Event Reports: When an event of an unusual and significant nature occurs at Project site, whether or not related directly to the Work, prepare and submit a special report. List chain of events, persons participating, responses by Contractor's personnel, evaluation of results or effects, and similar pertinent information. Advise Owner Project Officer in advance when these events are known or predictable.
1. Submit unusual event reports directly to Owner Project Officer within one day(s) of an occurrence. Distribute copies of report to parties affected by the occurrence.

PART 2 - PRODUCTS (Not Used)

PART 3 - EXECUTION (Not Used)

END OF SECTION 013200

Copyright 2015 by The American Institute of Architects (AIA)

SECTION 013233 - PHOTOGRAPHIC DOCUMENTATION

PART 1 - GENERAL

1.1 RELATED DOCUMENTS

- A. Drawings and general provisions of the Contract, including General and Supplementary Conditions and other Division 01 Specification Sections, apply to this Section.

1.2 SUMMARY

- A. Section includes administrative and procedural requirements for the following:
 - 1. Preconstruction photographs.
 - 2. Periodic construction photographs.
 - 3. Final completion construction photographs.
 - 4. Construction webcam.
- B. Related Requirements:
 - 1. Section 017700 "Closeout Procedures" for submitting photographic documentation as Project Record Documents at Project closeout.
 - 2. Section 017900 "Demonstration and Training" for submitting video recordings of demonstration of equipment and training of Owner's personnel.
 - 3. Section 311000 "Site Clearing" for photographic documentation before site clearing operations commence.

1.3 INFORMATIONAL SUBMITTALS

- A. Key Plan: Submit key plan of Project site and building with notation of vantage points marked for location and direction of each photograph. Indicate elevation or story of construction. Include same information as corresponding photographic documentation.
- B. Digital Photographs: Submit image files within three days of taking photographs.
 - 1. Submit photos by uploading to web-based project software site. Include copy of key plan indicating each photograph's location and direction.
 - 2. Identification: Provide the following information with each image description in file metadata tag:
 - a. Name of Project.
 - b. Name and contact information for photographer.
 - c. Name of Architect.
 - d. Name of Contractor.

- e. Date photograph was taken.
- f. Description of location, vantage point, and direction.
- g. Unique sequential identifier keyed to accompanying key plan.

1.4 QUALITY ASSURANCE

- A. Photographer Qualifications: An individual who has been regularly engaged as a professional photographer of construction projects for not less than three years.

1.5 FORMATS AND MEDIA

- A. Digital Photographs: Provide color images in JPG format, produced by a digital camera with minimum sensor size of 12 megapixels, and at an image resolution of not less than 3200 by 2400 pixels, and with vibration-reduction technology. Use flash in low light levels or backlit conditions.
- B. Digital Images: Submit digital media as originally recorded in the digital camera, without alteration, manipulation, editing, or modifications using image-editing software.
- C. Metadata: Record accurate date and time and GPS location data from camera.
- D. File Names: Name media files with date and sequential numbering suffix.

1.6 CONSTRUCTION PHOTOGRAPHS

- A. Photographer: Engage a qualified photographer to take construction photographs.
- B. General: Take photographs with maximum depth of field and in focus.
 - 1. Maintain key plan with each set of construction photographs that identifies each photographic location.
- C. Preconstruction Photographs: Before starting construction, take photographs of Project site and surrounding properties, including existing items to remain during construction, from different vantage points, as directed by the Owner.
 - 1. Take 20 photographs of existing buildings either on or adjoining property to accurately record physical conditions at start of construction.
- D. Periodic Construction Photographs: Take 30 photographs monthly coinciding with the cutoff date associated with each Application for Payment. Select vantage points to show status of construction and progress since last photographs were taken.
- E. Final Completion Construction Photographs: Take 20 photographs after date of Substantial Completion for submission as Project Record Documents. Owner will inform photographer of desired vantage points.

- F. Additional Photographs: Owner may request photographs in addition to periodic photographs specified. Additional photographs will be paid for by Change Order and are not included in the Contract Sum.
1. Three days' notice will be given, where feasible.
 2. In emergency situations, take additional photographs within 24 hours of request.
 3. Circumstances that could require additional photographs include, but are not limited to, the following:
 - a. Special events planned at Project site.
 - b. Immediate follow-up when on-site events result in construction damage or losses.
 - c. Photographs to be taken at fabrication locations away from Project site. These photographs are not subject to unit prices or unit-cost allowances.
 - d. Substantial Completion of a major phase or component of the Work.
 - e. Extra record photographs at time of final acceptance.
 - f. Owner's request for special publicity photographs.
- G. Web-Based Interface: Provide online interface to allow viewing of each high-definition digital still image captured and stored during construction, from the Internet.
1. Access Control: Provide password-protected access for Project team administered by Contractor, providing current image access and archival image access by date and time, with images downloadable to viewer's device.
 2. Storage: Maintain images on the website for reference during entire construction period, and for not less than 30 days after final completion. Provide sufficient memory on remote server to store all Project images.
 3. Online Interface: Provide website interface with Project and client information and logos; calendar-based navigation interface for selecting images; pan and zoom capability within high-definition images.
 4. Forward and Reverse: Provide capability to browse through images, moving forward and backward in time by individual image and by day.
 5. Slideshow: Provide capability to automatically display current images from sites when there are three or more cameras used.
 6. Time-Lapse: Provide capability for online display of project time-lapse.
 7. Dashboard: Provide capability to view thumbnails of all cameras on one screen.
 8. Weather: Provide corresponding weather data for each image captured.
- H. Maintain web-based access in good working order according to web-based construction photographic documentation service provider's written instructions until final completion. Provide for service of cameras and related networking devices and software.

PART 2 - PRODUCTS (Not Used)

PART 3 - EXECUTION (Not Used)

END OF SECTION 013233

THIS PAGE INTENSIONALLY LEFT BLANK

Copyright 2017 by The American Institute of Architects (AIA)

SECTION 014200 - REFERENCES

PART 1 - GENERAL

1.1 RELATED DOCUMENTS

- A. Drawings and general provisions of the Contract, including General and Supplementary Conditions and other Division 01 Specification Sections, apply to this Section.

1.2 DEFINITIONS

- A. General: Basic Contract definitions are included in the Conditions of the Contract.
- B. "Approved": When used to convey Architect's action on Contractor's submittals, applications, and requests, "approved" is limited to Architect's duties and responsibilities as stated in the Conditions of the Contract.
- C. "Directed": A command or instruction by Architect. Other terms including "requested," "authorized," "selected," "required," and "permitted" have the same meaning as "directed."
- D. "Indicated": Requirements expressed by graphic representations or in written form on Drawings, in Specifications, and in other Contract Documents. Other terms including "shown," "noted," "scheduled," and "specified" have the same meaning as "indicated."
- E. Reviewed: The term "reviewed" where used in conjunction with the Engineer's action on the Contractor's submittals, applications, and requests, is limited to the Engineer's duties and responsibilities as stated in the Conditions of the Contract.
- F. "Regulations": Laws, ordinances, statutes, and lawful orders issued by authorities having jurisdiction, and rules, conventions, and agreements within the construction industry that control performance of the Work.
- G. Recycled Content Materials: Building materials that contain in aggregate, a minimum weighted average of post consumer or post industrial recycled content material.
- H. Post Industrial Recycled Content: Building material generated by collection of waste material or by products of the manufacturing process.
- I. "Furnish": Supply and deliver to Project site, ready for unloading, unpacking, assembly, installation, and similar operations.
- J. "Install": Unload, temporarily store, unpack, assemble, erect, place, anchor, apply, work to dimension, finish, cure, protect, clean, and similar operations at Project site.

- K. Installer: An "Installer" is the Contractor, or an entity engaged by the Contractor, either as an employee, subcontractor, or contractor of lower tier for performance of a particular construction activity, including installation, erection, application, and similar operations. Installers are required to be experienced in the operations they are engaged to perform.
1. The term "experienced," when used with the term "Installer," means a person regularly engaged in this type of work, being familiar with the special requirements indicated, and having complied with requirements of the authority having jurisdiction.
 2. Trades: Use of titles such as "carpentry" is not intended to imply that certain construction activities must be performed by accredited or unionized individuals of a corresponding generic name, such as "carpenter." It also does not imply that requirements specified apply exclusively to tradespersons of the corresponding generic name.
 3. Assignment of Specialists: Certain Sections of the Specifications require that specific construction activities shall be performed by specialists who are recognized experts in the operations to be performed. The specialists must be engaged for those activities, and assignments are requirements over which the Contractor has no choice or option. Nevertheless, the ultimate responsibility for fulfilling Contract requirements remains with the Contractor.
 - a. This requirement shall not be interpreted to conflict with enforcement of building codes and similar regulations governing the Work. It is also not intended to interfere with local trade union jurisdictional settlements and similar conventions.
- L. "Provide": Furnish and install, complete and ready for the intended use.
- M. "Project Site": Space available for performing construction activities. The extent of Project site is shown on Drawings and may or may not be identical with the description of the land on which Project is to be built.
- N. Testing Laboratories: A "testing laboratory" is an independent entity engaged to perform specific inspections or tests, either at the Project Site or elsewhere, and to report on and, if required, to interpret results of those inspections or tests.

1.3 SPECIFICATION FORMAT AND CONTENT EXPLANATION

- A. Specification Format: These Specifications are organized into Divisions and Sections based on the Construction Specifications Institute's 50 Division format and MASTERFORMAT numbering system.
- B. Specification Content: This Specification uses certain conventions in the use of language and the intended meaning of certain terms, words, and phrases when used in particular situations or circumstances. These conventions are explained as follows:
1. Abbreviated Language: Language used in Specifications and other Contract Documents is the abbreviated type. Words and meanings shall be interpreted as appropriate. Words that are implied, but not stated shall be interpolated as the sense required. Singular words will be interpreted as plural and plural words interpreted as singular where applicable and the context of the Contract Documents so indicates.
 2. Imperative and streamlined language is used generally in the Specifications. Requirements expressed in the imperative mood are to be performed by the Contractor.

At certain locations in the text, for clarity, subjective language is used to describe responsibilities that must be fulfilled indirectly by the Contractor, or by others when so noted.

- a. The words "shall be" shall be included by inference wherever a colon (:) is used within a sentence or phrase.

1.4 INDUSTRY STANDARDS

- A. **Applicability of Standards:** Unless the Contract Documents include more stringent requirements, applicable construction industry standards have the same force and effect as if bound or copied directly into the Contract Documents to the extent referenced. Such standards are made a part of the Contract Documents by reference.
- B. **Publication Dates:** Comply with standards in effect as of date of the Contract Documents unless otherwise indicated.
- C. **Conflicting Requirements:** Where compliance with two or more standards is specified, and the standards may establish different or conflicting requirements for minimum quantities or quality levels. Refer requirements that are different, but apparently equal, and uncertainties to the Engineer for a decision before proceeding.
 1. **Minimum Quantity or Quality Levels:** The quantity or quality level shown or specified shall be the minimum provided or performed. The actual installation may comply exactly with the minimum quantity or quality specified, or it may exceed the minimum within reasonable limits. In complying with these requirements, indicated numeric values are minimum or maximum, as appropriate for the context of the requirements. Refer uncertainties to the Engineer for a decision before proceeding.
- D. **Copies of Standards:** Each entity engaged in construction on Project should be familiar with industry standards applicable to its construction activity. Copies of applicable standards are not bound with the Contract Documents.
 1. Where copies of standards are needed to perform a required construction activity, obtain copies directly from publication source.

1.5 ABBREVIATIONS AND ACRONYMS

- A. **Industry Organizations:** Where abbreviations and acronyms are used in Specifications or other Contract Documents, they shall mean the recognized name of the entities indicated in Gale's "Encyclopedia of Associations: National Organizations of the U.S." or in Columbia Books' "National Trade & Professional Associations of the United States."
- B. **Code Agencies:** Where abbreviations and acronyms are used in Specifications or other Contract Documents, they shall mean the recognized name of the entities in the following list. This information is believed to be accurate as of the date of the Contract Documents.
 1. ICC - International Code Council; www.iccsafe.org.

- C. Federal Government Agencies: Where abbreviations and acronyms are used in Specifications or other Contract Documents, they shall mean the recognized name of the entities in the following list. Information is subject to change and is up to date as of the date of the Contract Documents.
1. DOC - Department of Commerce; National Institute of Standards and Technology; www.nist.gov.
 2. DOE - Department of Energy; www.energy.gov.
 3. EPA - Environmental Protection Agency; www.epa.gov.
 4. OSHA - Occupational Safety & Health Administration; www.osha.gov.
 5. SD - Department of State; www.state.gov.
 6. USDOJ - Department of Justice; Office of Justice Programs; National Institute of Justice; www.ojp.usdoj.gov.

1.6 GOVERNING REGULATIONS/AUTHORITIES

- A. The Architect/Engineer has contacted authorities having jurisdiction where necessary to obtain information necessary for preparation of Contract Documents. Contact authorities having jurisdiction directly for information and decisions having a bearing on the Work.
- B. Copies of Regulations: Obtain copies of the following applicable regulations and retain at the Project Site, available for reference by parties who have a reasonable need for such reference.
- C. VA Uniform Statewide Building Code – VUSBC 2015.
1. Current list of codes and ordinances in use by Arlington County:
 - a. ICC International Building Code/2015 VCC
 - b. ICC International Residential Code/2015 VRC
 - c. NFPA National Electrical Code/2011
 - d. ICC International Mechanical Code/2015
 - e. ICC International Fuel Gas Code/2015
 - f. ICC International Plumbing Code/2015
 - g. ICC/ANSI A117.1/2009
 - h. ICC International Energy Conservation Code/2015
 - i. ICC International Property Maintenance Code/2015
 2. Verify current codes and standards in use by Arlington County at the following site: <https://building.arlingtonva.us/codes-ordinances/>.
- D. Arlington County Infrastructure Design and Construction Standards, including Amendments.
- E. Americans with Disabilities Act Accessibility Guidelines (ADAAG)
1. Available from the Organization - <https://www.access-board.gov/guidelines-and-standards/buildings-and-sites/about-the-ada-standards/background/adaag> .

1.7 SUBMITTALS

- A. Permits, Licenses, and Certificates: For the Owner's records, submit copies of permits, licenses, certifications, inspection reports, releases, jurisdictional settlements, notices, receipts for fee payments, judgments, and similar documents, correspondence, and records established in conjunction with compliance with standards and regulations bearing upon performance of the Work.

PART 2 - PRODUCTS (Not Used)

PART 3 - EXECUTION (Not Used)

END OF SECTION 014200

THIS PAGE INTENSIONALLY LEFT BLANK

Copyright 2017 by The American Institute of Architects (AIA)

SECTION 015000 - TEMPORARY FACILITIES AND CONTROLS

PART 1 - GENERAL

1.1 RELATED DOCUMENTS

- A. Drawings and general provisions of the Contract, including General and Supplementary Conditions and other Division 01 Specification Sections, apply to this Section.

1.2 SUMMARY

- A. Section includes requirements for temporary utilities, support facilities, and security and protection facilities. In addition to the specifications contained herein, Work shall be performed in accordance with the Arlington County Department of Parks & Recreation Design Standards for Tree Protection and Trimming as shown on plans and available online at:

<http://parks.arlingtonva.us/design-standards/>

- B. Related Requirements:

1. Section 011000 "Summary" for work restrictions and limitations on utility interruptions.
2. Section 311000 "Site Clearing" for temporary water dispersal procedures.
3. Section 312000 "Earth Moving" for disposal of ground water at Project site.

- C. Applicable Regulations

1. Erosion and Sediment Control (Chapter 57 of the Arlington County Code)
2. Utilities (Chapter 26 of the Arlington County Code)
3. Stormwater Management (Chapter 60 of the Arlington County Code)
4. Chesapeake Bay Preservation Ordinance (Chapter 61 of the Arlington County Code)
5. Trees and Shrubs (Chapter 67 of the Arlington County Code)
6. Virginia State Water Control Board Regulations

- D. Applicable References

1. Virginia Erosion and Sediment Control Handbook
2. Arlington County Stormwater Management Ordinance Guidance Manual
3. Arlington County Planning Guide to Erosion and Sediment Control
4. Arlington County Pre-Storm Erosion and Sediment Control Checklist
5. Arlington County Planning & Field Guide for Pollution Prevention (P2)
6. Arlington County Tree Protection and Planting Standards

1.3 USE CHARGES

- A. General: Installation and removal of and use charges for temporary facilities shall be included in the Contract Sum unless otherwise indicated. Allow other entities engaged in the Project to use temporary services and facilities without cost, including, but not limited to, Project Engineer, testing agencies, and authorities having jurisdiction.
- B. Sewer Service: County will pay sewer-service use charges for sewer usage by all entities for construction operations with the exception of exterior restroom facilities for the Contractor's team.
- C. Water Service: County will pay water-service use charges for water used by all entities for construction operations with the exception of exterior restroom facilities for the Contractor's team.
- D. Electric Power Service: County will pay electric-power-service use charges for electricity used by all entities for construction operations.
- E. Water and Sewer Service from Existing System: Water from County's existing water system is available for use without metering and without payment of use charges. Provide connections and extensions of services as required for construction operations.
- F. Electric Power Service from Existing System: Electric power from County's existing system is available for use without metering and without payment of use charges. Provide connections and extensions of services as required for construction operations.
 - 1. Provide electric power service and distribution system of sufficient size, capacity, and power characteristics required for construction operations.
 - 2. Connect temporary service to the existing power source, as directed by the CM.

1.4 INFORMATIONAL SUBMITTALS

- A. Site Utilization Plan: Show temporary facilities, temporary utility lines and connections, staging areas, construction site entrances, vehicle circulation, and parking areas for construction personnel.
- B. Implementation and Termination Schedule: Within 15 days of date established for commencement of the Work, submit schedule indicating implementation and termination dates of each temporary utility.
- C. Stormwater Pollution Prevention Plan (SWPPP): Required for any activity that disturbs greater than or equal to 2500 square feet per the requirements of Arlington County Code Chapter 60. This plan contains the following elements:
 - 1. Erosion and Sediment (E&S) Control Plan
 - 2. Pollution Prevention Plan (P2 Plan)
 - 3. Stormwater Management Plan (SWMP)
 - 4. Virginia Stormwater Management Program (VSMP) Requirements where applicable

- D. Where work is governed by an approved SWPPP, the Contractor shall be responsible for all SWPPP self-inspection and documentation requirements. Where work is governed by an approved SWPPP, the Contractor shall be responsible for all SWPPP self-inspection and documentation requirements which includes but is not limited to the following:
1. A SWPPP box is installed and maintained at project site.
 2. Permit(s) and applicable documentation are posted near the SWPPP box.
 3. All sections of the SWPPP are kept complete and up to date throughout the duration of the project. (For example, notation of when erosion and sediment controls (ESC) are installed and information about the types of pollution prevention measures used.)
 4. Any modifications to controls are documented in the SWPPP, which includes the ESC plan.
 5. Self-inspections are conducted every four business days or as required.
 6. Completed and signed inspection reports are kept at the project site.
 7. Items identified during inspections requiring correction action are properly documented and addressed.
 8. The ESC Pre-storm checklist provided in the plan / SWPPP is used and followed accordingly.
- E. Permits: The Contractor is responsible for complying with all applicable State, Federal, and Local permits which are required for construction, including, but not limited to:
1. Virginia Water Protection Permits issued by the Virginia DEQ
 2. General Nationwide Permits issued by the US Army Corps of Engineers
 3. Land Disturbing Activity (LDA) permits (Virginia Stormwater Management Program (VSMP) authority permits) issued by Arlington County
 4. General Virginia Pollutant Discharge Elimination System (VPDES) Permit for Discharges of Stormwater from Construction Activity issued by Virginia DEQ.
 5. A separate VPDES permit, issued by DEQ may be required for certain non-stormwater discharges such as contaminated groundwater.
- F. Project Identification and Temporary Signs: Show fabrication and installation details, including plans, elevations, details, layouts, typestyles, graphic elements, and message content.
- G. Erosion and Sedimentation-Control Plan: Show compliance with requirements of EPA Construction General Permit or authorities having jurisdiction, whichever is more stringent.
- H. Fire-Safety Program: Show compliance with requirements of NFPA 241 and authorities having jurisdiction. Indicate Contractor personnel responsible for management of fire-prevention program.
1. 1. Fire Extinguishers: Portable, UL rated; with class and extinguishing agent as required by locations and classes of fire exposures
- I. Moisture- and Mold-Protection Plan: Describe procedures and controls for protecting materials and construction from water absorption and damage and mold.
- J. Dust- and HVAC-Control Plan: Submit coordination drawing and narrative that indicates the dust- and HVAC-control measures proposed for use, proposed locations, and proposed time frame for their operation. Include the following:

1. Locations of dust-control partitions at each phase of work.
2. HVAC system isolation schematic drawing.
3. Location of proposed air-filtration system discharge.
4. Waste-handling procedures.
5. Other dust-control measures.

K. Equipment

1. Heating and Cooling: Provide temporary heating and cooling required by construction activities for curing or drying of completed installations or for protecting installed construction from adverse effects of low temperatures or high humidity. Select equipment that will not have a harmful effect on completed installations or elements being installed.
2. Ventilation and Humidity Control: Provide temporary ventilation required by construction activities for curing or drying of completed installations or for protecting installed construction from adverse effects of high humidity. Select equipment that will not have a harmful effect on completed installations or elements being installed. Coordinate ventilation requirements to produce ambient condition required and minimize energy consumption.
 - a. Provide dehumidification systems when required to reduce substrate moisture levels to level required to allow installation or application of finishes.
3. Lighting: Provide temporary lighting with local switching that provides adequate illumination for construction operations (per OSHA Standards), observations, inspections, and traffic conditions.
 - a. Install and operate temporary lighting that fulfills security and protection requirements without operating entire system.
4. Waste Disposal Facilities: Comply with requirements specified in Division 1 Section "Construction Waste Management."
5. Waste Disposal Facilities: Provide waste-collection containers in sizes adequate to handle waste from construction operations. Comply with requirements of authorities having jurisdiction. Comply with Division 1 Section "Execution Requirements" for progress cleaning requirements.

1.5 QUALITY ASSURANCE

- A. Electric Service: Comply with NECA, NEMA, and UL standards and regulations for temporary electric service. Install service to comply with NFPA 70.
- B. Tests and Inspections: Arrange for authorities having jurisdiction to test and inspect each temporary utility before use. Obtain required certifications and permits.
- C. Accessible Temporary Egress: Comply with applicable provisions in the United States Access Board's ADA-ABA Accessibility Guidelines and ICC/ANSI A117.1.

1.6 PROJECT CONDITIONS

- A. Temporary Use of Permanent Facilities: Engage Installer of each permanent service to assume responsibility for operation, maintenance, and protection of each permanent service during its

use as a construction facility before County's acceptance, regardless of previously assigned responsibilities.

PART 2 - PRODUCTS

2.1 MATERIALS

- A. Portable Chain-Link Fencing: Minimum 2-inch, 0.148-inch-thick, galvanized-steel, chain-link fabric fencing; minimum 6 feet high with galvanized-steel pipe posts; minimum 2-3/8-inch-OD line posts and 2-7/8-inch-OD corner and pull posts, with 1-5/8-inch-OD top and bottom rails. Provide concrete bases for supporting posts.
- B. Fencing Windscreen Privacy Screen: Polyester fabric scrim with grommets for attachment to chain link fence, sized to height of fence, in color selected by Architect from manufacturer's standard colors.
- C. Polyethylene Sheet: Reinforced, fire-resistive sheet, 10-mil minimum thickness, with flame-spread rating of 15 or less per ASTM E 84 and passing NFPA 701 Test Method 2.
- D. Dust-Control Adhesive-Surface Walk-Off Mats: Provide mats minimum 36 by 60 inches.
- E. Insulation: Unfaced mineral-fiber blanket, manufactured from glass, slag wool, or rock wool; with maximum flame-spread and smoke-developed indexes of 25 and 50, respectively.
- F. Gypsum Board: Minimum 1/2 inch (12.7 mm) thick by 48 inches (1219 mm) wide by maximum available lengths; regular-type panels with tapered edges. Comply with ASTM C 36/C 36M.

2.2 TEMPORARY FACILITIES

- A. Field Offices, General: Prefabricated or mobile units with serviceable finishes, temperature controls, and above ground foundations adequate for normal loading. The field office shall be set up in an acceptable location, and in proximity to sewer/water lines when practicable. It is the Contractor's responsibility to secure the location of the field office. The field office shall be equipped and completely operational for use three days prior to start of any work, and shall remain at the site until field records pertinent to the project have been completed, not to exceed 30 calendar days after acceptable completion of all Contract work
- B. Common-Use Field Office: Of sufficient size to accommodate needs of Owner, Architect, and construction personnel office activities and to accommodate Project meetings specified in other Division 01 Sections. Keep office clean and orderly. Furnish and equip offices as follows:
 - 1. Furniture required for Project-site documents including file cabinets, shelving, plan table etc.
 - 2. Conference area of sufficient size to accommodate meetings of at least 8 individuals. Provide electrical power service and 120-V ac duplex receptacles, with no fewer than one receptacle on each wall. Furnish room with conference table, chairs, and marker boards.

3. Adequate Drinking water and private toilet.
 4. Adequate Heating and cooling equipment necessary to maintain a uniform indoor temperature of 68 to 72 deg F.
 5. Lighting fixtures capable of maintaining average illumination of 20 fc at desk height.
 6. Utility service (electricity, DSL or broadband internet connection, water and sewer).
 7. Adequate windows
 8. Fire Extinguisher
 9. Secure door lock
 10. Sanitary facilities
 11. Adequate janitorial service (removal of waste, etc.)
- C. Storage and Fabrication Sheds: Provide sheds sized, furnished, and equipped to accommodate materials and equipment for construction operations. The contractor shall work within the staging areas as noted on the contract drawings.

2.3 EQUIPMENT

- A. Fire Extinguishers: Portable, UL rated; with class and extinguishing agent as required by locations and classes of fire exposures.
- B. HVAC Equipment: Provide vented, self-contained, liquid-propane-gas or fuel-oil heaters with individual space thermostatic control.
1. Use of gasoline-burning space heaters, open-flame heaters, or salamander-type heating units is prohibited.
 2. Heating Units: Listed and labeled for type of fuel being consumed, by a qualified testing agency acceptable to authorities having jurisdiction and marked for intended location and application.
- C. Air-Filtration Units: Primary and secondary HEPA-filter-equipped portable units with four-stage filtration. Provide single switch for emergency shutoff. Configure to run continuously.

PART 3 - EXECUTION

3.1 TEMPORARY FACILITIES, GENERAL

- A. Conservation: Coordinate construction and use of temporary facilities with consideration given to conservation of energy, water, and materials. Coordinate use of temporary utilities to minimize waste.
1. Salvage materials and equipment involved in performance of, but not actually incorporated into, the Work. See other Sections for disposition of salvaged materials that are designated as County's property.

3.2 INSTALLATION, GENERAL

- A. Locate facilities where they will serve Project adequately and result in minimum interference with performance of the Work. Relocate and modify facilities as required by progress of the Work.
 - 1. Locate facilities to limit site disturbance as specified in Section 011000 "Summary."
- B. Provide each facility ready for use when needed to avoid delay. Do not remove until facilities are no longer needed or are replaced by authorized use of completed permanent facilities.

3.3 TEMPORARY UTILITY INSTALLATION

- A. General: Install temporary service or connect to existing service.
 - 1. Arrange with utility company, Owner Project Officer, and existing users for time when service can be interrupted, if necessary, to make connections for temporary services.
- B. Sewers and Drainage: Provide temporary utilities to remove effluent lawfully.
 - 1. Connect temporary sewers to municipal system as directed by authorities having jurisdiction.
- C. Water Service: Connect to County's existing water service facilities. Clean and maintain water service facilities in a condition acceptable to the County. At Substantial Completion, restore these facilities to condition existing before initial use. Install water service and distribution piping in sizes and pressures adequate for construction.
- D. Sanitary Facilities: Provide temporary toilets, wash facilities, and drinking water for use of construction personnel. Comply with requirements of authorities having jurisdiction for type, number, location, operation, and maintenance of fixtures and facilities.
- E. Temporary Heating and Cooling: Provide temporary heating and cooling required by construction activities for curing or drying of completed installations or for protecting installed construction from adverse effects of low temperatures or high humidity. Select equipment that will not have a harmful effect on completed installations or elements being installed.
 - 1. Provide temporary dehumidification systems when required to reduce ambient and substrate moisture levels to level required to allow installation or application of finishes and their proper curing or drying.
 - 2. Perform daily construction cleanup and final cleanup using approved, HEPA-filter-equipped vacuum equipment.
- F. Electric Power Service: Provide electric power service and distribution system of sufficient size, capacity, and power characteristics required for construction operations.
 - 1. Install electric power service overhead unless otherwise indicated.
 - 2. Connect temporary service to County's existing power source, as directed by County.

- G. Lighting: Provide temporary lighting with local switching that provides adequate illumination for construction operations, observations, inspections, and traffic conditions.
 - 1. Install and operate temporary lighting that fulfills security and protection requirements without operating entire system.
- H. Telephone Service: Provide temporary telephone service in common-use facilities for use by all construction personnel. Install WiFi cell phone access equipment and one land-based telephone line(s) for each field office.
 - 1. At each telephone, post a list of important telephone numbers.
 - a. Police and fire departments.
 - b. Ambulance service.
 - c. Contractor's home office.
 - d. Contractor's emergency after-hours telephone number.
 - e. Architect's office.
 - f. Engineers' offices.
 - g. Owner's office.
 - h. Principal subcontractors' field and home offices.

3.4 SUPPORT FACILITIES INSTALLATION

- A. General: Comply with the following:
 - 1. Provide construction for temporary offices, shops, and sheds located within construction area or within 30 feet of building lines that is noncombustible according to ASTM E 136. Comply with NFPA 241.
 - 2. Maintain support facilities until Architect Schedules Substantial Completion inspection. Remove before Substantial Completion. Personnel remaining after Substantial Completion will be permitted to use permanent facilities, under conditions acceptable to County.
- B. Temporary Roads and Paved Areas: Construct and maintain temporary roads and paved areas adequate for construction operations. Locate temporary roads and paved areas as indicated on Drawings.
 - 1. Provide dust-control treatment that is nonpolluting and nontracking. Reapply treatment as required to minimize dust.
- C. Temporary Use of Planned Permanent Roads and Paved Areas: Locate temporary roads and paved areas in same location as permanent roads and paved areas. Construct and maintain temporary roads and paved areas adequate for construction operations. Extend temporary roads and paved areas, within construction limits indicated, as necessary for construction operations.
 - 1. Coordinate elevations of temporary roads and paved areas with permanent roads and paved areas.
 - 2. Prepare subgrade and install subbase and base for temporary roads and paved areas according to Section 312000 "Earth Moving."

3. Recondition base after temporary use, including removing contaminated material, regrading, proofrolling, compacting, and testing.
 4. Delay installation of final course of permanent hot-mix asphalt pavement until immediately before Substantial Completion. Repair hot-mix asphalt base-course pavement before installation of final course according to Section 321216 "Asphalt Paving."
- D. Traffic Controls: Comply with requirements of authorities having jurisdiction.
1. Protect existing site improvements to remain including curbs, pavement, and utilities.
 2. Maintain access for fire-fighting equipment and access to fire hydrants.
 3. The Contractor shall provide a traffic control plan and devices including qualified flagman during delivery of material and equipment or during performance of site work. Contractor shall work in tandem with building security to assure all vehicles entering and leaving the building have full access and priority at all times.
- E. Parking: Provide temporary parking areas for construction personnel.
- F. Dewatering Facilities and Drains: Comply with requirements of authorities having jurisdiction. Maintain Project site, excavations, and construction free of water.
1. Dispose of rainwater in a lawful manner that will not result in flooding Project or adjoining properties or endanger permanent Work or temporary facilities.
 2. Remove snow and ice as required to minimize accumulations.
- G. Project Signs: Provide Project signs as indicated. Unauthorized signs are not permitted.
1. Identification Signs: Provide, permit, and install project identification signs as indicated in the Special Conditions, on Drawings, and in the specifications.
 2. Temporary Signs: Provide other signs as indicated and as required to inform public and individuals seeking entrance to Project.
 - a. Provide temporary, directional signs for construction personnel and visitors.
 3. Maintain and touch up signs so they are legible at all times.
- H. Waste Disposal Facilities: Comply with requirements specified in Section 017419 "Construction Waste Management and Disposal."
- I. Waste Disposal Facilities: Provide waste-collection containers in sizes adequate to handle waste from construction operations. Comply with requirements of authorities having jurisdiction. Comply with progress cleaning requirements in Section 017300 "Execution."
- J. Lifts and Hoists: Provide facilities necessary for hoisting materials and personnel.
1. Truck cranes and similar devices used for hoisting materials are considered "tools and equipment" and not temporary facilities.
- K. Temporary Use of Permanent Stairs: Use of new stairs for construction traffic will be permitted, provided stairs are protected and finishes restored to new condition at time of Substantial Completion.

3.5 SECURITY AND PROTECTION FACILITIES INSTALLATION

- A. Protection of Existing Facilities: Protect existing vegetation, equipment, structures, utilities, and other improvements at Project site and on adjacent properties, except those indicated to be removed or altered. Repair damage to existing facilities.
1. Where access to adjacent properties is required in order to affect protection of existing facilities, obtain written permission from adjacent property owner to access property for that purpose.
- B. Environmental Protection: Provide protection, operate temporary facilities, and conduct construction as required to comply with environmental regulations and that minimize possible air, waterway, and subsoil contamination or pollution or other undesirable effects.
1. Comply with work restrictions specified in Section 011000 "Summary."
- C. Temporary Erosion and Sedimentation Control: Comply with requirements of EPA Construction General Permit or authorities having jurisdiction, whichever is more stringent, and requirements specified in Section 311000 "Site Clearing."
- D. Temporary Erosion and Sedimentation Control: Provide measures to prevent soil erosion and discharge of soil-bearing water runoff and airborne dust to undisturbed areas and to adjacent properties and walkways, according to erosion- and sedimentation-control Drawings requirements of EPA Construction General Permit or authorities having jurisdiction, whichever is more stringent.
1. Verify that flows of water redirected from construction areas or generated by construction activity do not enter or cross tree- or plant-protection zones.
 2. Inspect, repair, and maintain erosion- and sedimentation-control measures during construction until permanent vegetation has been established.
 3. Clean, repair, and restore adjoining properties and roads affected by erosion and sedimentation from Project site during the course of Project.
 4. Remove erosion and sedimentation controls and restore and stabilize areas disturbed during removal.
- E. Temporary Erosion and Sedimentation Control: Where work is governed by an approved SWPPP, the contractor shall follow the plan and Erosion and Sediment Control Pre-Storm Checklist, which includes but is not limited to the conditions below. Where the work is not governed by an approved SWPPP, the contractor shall meet the conditions below as well as those specified in the Erosion and Sediment Control Pre-Storm Checklist.
1. The Contractor, prior to starting work, shall properly protect storm drains to prevent pollutants, waste materials, sediment, or non-stormwater discharges from entering the storm drain system. The Contractor shall implement and maintain controls as specified in the Virginia Erosion and Sediment Control Handbook and/or approved Stormwater Pollution Prevention Plan. Controls, practices, and/or devices must be monitored and maintained at all times to ensure proper operation condition.
 2. No grading operations will be allowed until erosion and sediment controls have been installed in accordance with the approved plan conforming to the requirements of Virginia Erosion and Sediment Control regulations and Arlington County Erosion and Sediment Control Ordinance.

3. The Contractor shall keep stockpiled materials covered and perimeter controls shall be employed to minimize exposure to wind, precipitation, and runoff.
 4. The Contractor shall implement and maintain dewatering methods as specified in Arlington County Construction Standards and Specifications, VA Erosion and Sediment Control Handbook, Arlington County Planning & Field Guide to Erosion and Sediment Control, Arlington County Planning & Field Guide for Pollution Prevention (P2) and/or approved Stormwater Pollution Prevention Plan. Controls, practices, and/or devices used for dewatering operations must be monitored and maintained at all times to ensure proper operation.
 5. The Contractor shall conduct dewatering operations in a manner to prevent sediment or other pollutants from discharging to the County's storm drain system, which includes the curb and gutter, or any surface water. Dewatering operations shall not create any erosion or flooding. Dewatering discharges that contain chemicals, hydrocarbons, or sewage shall not be discharged to the storm drain system. Any discharge from dewatering operations shall be properly filtered prior to being discharged. A dewatering plan with sufficient detail to ensure the proposed dewatering will comply with applicable regulations must be included as part of the erosion and sediment control plan.
 6. The Contractor is responsible for the installation and maintenance of any additional erosion and sediment control (ESC) measures necessary to prevent erosion and sedimentation as determined by the County, including but not limited to the actions listed in the County's Erosion and Sediment Control Pre-Storm Checklist (perimeter controls, slope stabilization, and covering stockpiles). Erosion and sediment controls shall be modified as needed to ensure clear water is discharged from the site. The County reserves the right to order the implementation of other erosion and sediment controls not specifically described herein to correct an erosion or pollution discharge condition.
 7. Control measures shall be properly maintained in accordance with state and local regulations. Immediately after every rainstorm, all control measures shall be inspected and any deficiencies corrected by the Contractor.
 8. Erosion and sediment controls shall be removed when the area has been stabilized and approval has been granted by the construction inspector.
 9. No further work will be allowed until erosion and sediment controls for the applicable phase have been installed in accordance with the approved plan conforming to the requirements of Virginia Erosion and Sediment Control regulations and Arlington County Erosion and Sediment Control Ordinance.
- F. Stormwater Control: Comply with requirements of authorities having jurisdiction. Provide barriers in and around excavations and subgrade construction to prevent flooding by runoff of stormwater from heavy rains.
- G. Stormwater Control: Where work is governed by an approved SWPPP, the contractor shall follow the plan, which includes but is not limited to the conditions below. Where the work is not governed by an approved SWPPP, the contractor shall meet the conditions below.
1. The Contractor shall employ good housekeeping at work sites at all times. The Contractor shall collect, remove and legally dispose of all refuse, trash, litter, waste materials, and/or debris generated at the work site as frequently as necessary to prevent pollution releases from the site. Liquid waste must be properly contained prior to being placed into a waste receptacle to prevent leaking. The County, in its sole discretion, may require the Contractor to provide disposal tickets or other information sufficiently demonstrating legal disposal.

2. The Contractor shall contain, capture, collect and legally dispose of any unauthorized non-stormwater discharge(s), including but not limited to, saw cut slurry from saw cutting operations, concrete / asphalt wash water, waste water, and / or wash water from equipment, material, and/or vehicle washing.
3. A vacuum system shall be used to collect liquid waste / slurry generated from saw cutting operations to prevent a discharge to a storm drain or surface water. Collected slurry must be disposed of at an approved waste receiving facility (e.g. landfill, soil safe, waste water treatment plant, commercial dump pad).
4. Methods used for capturing / collecting unauthorized non-stormwater discharges must be on site and operational prior to starting any work that will generate a non-stormwater discharge.
5. The Contractor shall have designated wash out areas or containers for materials, including but not limited to concrete, asphalt, paint, grout, mortar, stucco, form release oil, curing compounds, and /or sealers.
6. Construction materials shall be properly stored and secured to ensure no pollutants are released into the environment.
7. The Contractor shall ensure waste receptacles and portable lavatories are not damaged and/or leaking.
8. The Contractor shall ensure spill clean-up materials (including but not limited to absorbent materials, spill pads, rags, booms, bags for waste disposal) and tools (including but not limited to shovels, brooms, containers, vacuums) are kept on the work site and accessible at all times. Spills and leaks shall be cleaned up as soon as discovered and wastes properly disposed of at an approved waste receiving facility. Spills shall not be washed into a street, storm drain, or surface waters.
9. The Contractor shall ensure that the County's procedures for disposing of chlorinated water are followed (DES Construction Standards and Specifications, Section 02550 4.12 Discharge of Chlorinated Water).
10. The Contractor shall not dump or dispose of anything in a storm drain, street, or stream that is not authorized under the County's VSMP MS4 permit or violates County Code Chapter 26-5 B and/or C.

H. Extent of Grading Operations:

1. The Contractor shall limit the surface area of earth material exposed by grubbing, stripping of topsoil and excavation to that which is necessary to perform the next operation within a given area.
2. Unless specifically authorized by the Project Officer, the grubbing of root mat and stumps shall be confined to the area over which excavation is to be actively conducted within 30 days following the grubbing operations.
3. The stripping of topsoil shall be confined to the area over which excavation is to be actively prosecuted within 15 days following the stripping operations; and excavation and embankment construction shall be confined to the minimum area necessary to accommodate the Contractor's equipment and work force engaged in the earth moving work.
4. No disturbed area, including stockpiles, shall remain denuded longer than 7 days without temporary seeding or application of other stabilization practices approved by the Project Officer.

I. Tree and Plant Protection: Comply with requirements specified in Section 015639 "Temporary Tree and Plant Protection."

- J. Tree and Plant Protection: Install temporary fencing located as indicated or outside the drip line of trees to protect vegetation from damage from construction operations. Protect tree root systems from damage, flooding, and erosion.
- K. Pest Control: Engage pest-control service to recommend practices to minimize attraction and harboring of rodents, roaches, and other pests and to perform extermination and control procedures at regular intervals so Project will be free of pests and their residues at Substantial Completion. Perform control operations lawfully, using materials approved by authorities having jurisdiction.
- L. Site Enclosure Fence: Before construction operations begin, furnish and install site enclosure fence in a manner that will prevent people from easily entering site except by entrance gates.
 - 1. Extent of Fence: As required to enclose entire Project site or portion determined sufficient to accommodate construction operations.
 - 2. Maintain security by limiting number of keys and restricting distribution to authorized personnel. Furnish one set of keys to County.
- M. Security Enclosure and Lockup: Install temporary enclosure around partially completed areas of construction. Provide lockable entrances to prevent unauthorized entrance, vandalism, theft, and similar violations of security. Lock entrances at end of each workday.
- N. Barricades, Warning Signs, and Lights: Comply with requirements of authorities having jurisdiction for erecting structurally adequate barricades, including warning signs and lighting.
- O. Temporary Egress: Maintain temporary egress from existing occupied facilities as indicated and as required by authorities having jurisdiction.
- P. Temporary Enclosures: Provide temporary enclosures for protection of construction, in progress and completed, from exposure, foul weather, other construction operations, and similar activities. Provide temporary weathertight enclosure for building exterior.
 - 1. Where heating or cooling is needed, and permanent enclosure is incomplete, insulate temporary enclosures.
- Q. Temporary Fire Protection: Install and maintain temporary fire-protection facilities of types needed to protect against reasonably predictable and controllable fire losses. Comply with NFPA 241; manage fire-prevention program.
 - 1. Prohibit smoking in construction areas. Comply with additional limits on smoking specified in other Sections.
 - 2. Supervise welding operations, combustion-type temporary heating units, and similar sources of fire ignition according to requirements of authorities having jurisdiction.
 - 3. Develop and supervise an overall fire-prevention and -protection program for personnel at Project site. Review needs with local fire department and establish procedures to be followed. Instruct personnel in methods and procedures. Post warnings and information.
 - 4. Provide temporary standpipes and hoses for fire protection. Hang hoses with a warning sign stating that hoses are for fire-protection purposes only and are not to be removed. Match hose size with outlet size and equip with suitable nozzles.

3.6 MOISTURE AND MOLD CONTROL

- A. Contractor's Moisture-Protection Plan: Describe delivery, handling, storage, installation, and protection provisions for materials subject to water absorption or water damage.
1. Indicate procedures for discarding water-damaged materials, protocols for mitigating water intrusion into completed Work, and replacing water-damaged Work.
 2. Indicate sequencing of work that requires water, such as sprayed fire-resistive materials, plastering, and terrazzo grinding, and describe plans for dealing with water from these operations. Show procedures for verifying that wet construction has dried sufficiently to permit installation of finish materials.
 3. Indicate methods to be used to avoid trapping water in finished work.
- B. Exposed Construction Period: Before installation of weather barriers, when materials are subject to wetting and exposure and to airborne mold spores, protect as follows:
1. Protect porous materials from water damage.
 2. Protect stored and installed material from flowing or standing water.
 3. Keep porous and organic materials from coming into prolonged contact with concrete.
 4. Remove standing water from decks.
 5. Keep deck openings covered or dammed.
- C. Partially Enclosed Construction Period: After installation of weather barriers but before full enclosure and conditioning of building, when installed materials are still subject to infiltration of moisture and ambient mold spores, protect as follows:
1. Do not load or install drywall or other porous materials or components, or items with high organic content, into partially enclosed building.
 2. Keep interior spaces reasonably clean and protected from water damage.
 3. Periodically collect and remove waste containing cellulose or other organic matter.
 4. Discard or replace water-damaged material.
 5. Do not install material that is wet.
 6. Discard and replace stored or installed material that begins to grow mold.
 7. Perform work in a sequence that allows wet materials adequate time to dry before enclosing the material in gypsum board or other interior finishes.
- D. Controlled Construction Period: After completing and sealing of the building enclosure but prior to the full operation of permanent HVAC systems, maintain as follows:
1. Control moisture and humidity inside building by maintaining effective dry-in conditions.
 2. Use temporary or permanent HVAC system to control humidity within ranges specified for installed and stored materials.
 3. Comply with manufacturer's written instructions for temperature, relative humidity, and exposure to water limits.
 - a. Hygroscopic materials that may support mold growth, including wood and gypsum-based products, that become wet during the course of construction and remain wet for 48 hours are considered defective and require replacing.
 - b. Measure moisture content of materials that have been exposed to moisture during construction operations or after installation. Record readings beginning at time of

exposure and continuing daily for 48 hours. Identify materials containing moisture levels higher than allowed. Report findings in writing to Architect.

- c. Remove and replace materials that cannot be completely restored to their manufactured moisture level within 48 hours.

3.7 OPERATION, TERMINATION, AND REMOVAL

- A. Supervision: Enforce strict discipline in use of temporary facilities. To minimize waste and abuse, limit availability of temporary facilities to essential and intended uses.
- B. Maintenance: Maintain facilities in good operating condition until removal.
 1. Maintain operation of temporary enclosures, heating, cooling, humidity control, ventilation, and similar facilities on a 24-hour basis where required to achieve indicated results and to avoid possibility of damage.
- C. Temporary Facility Changeover: Do not change over from using temporary security and protection facilities to permanent facilities until Substantial Completion.
- D. Termination and Removal: Remove each temporary facility when need for its service has ended, when it has been replaced by authorized use of a permanent facility, or no later than Substantial Completion. Complete or, if necessary, restore permanent construction that may have been delayed because of interference with temporary facility. Repair damaged Work, clean exposed surfaces, and replace construction that cannot be satisfactorily repaired.
 1. Materials and facilities that constitute temporary facilities are property of Contractor. County reserves right to take possession of Project identification signs.
 2. Remove temporary roads and paved areas not intended for or acceptable for integration into permanent construction. Where area is intended for landscape development, remove soil and aggregate fill that do not comply with requirements for fill or subsoil. Remove materials contaminated with road oil, asphalt and other petrochemical compounds, and other substances that might impair growth of plant materials or lawns. Repair or replace street paving, curbs, and sidewalks at temporary entrances, as required by authorities having jurisdiction. Finish grounds occupied by temporary facilities as scheduled and indicated on the drawings.
 3. At Substantial Completion, repair, renovate, and clean permanent facilities used during construction period. Comply with final cleaning requirements specified in Section 017700 "Closeout Procedures."

END OF SECTION 015000

THIS PAGE INTENSIONALLY LEFT BLANK

SECTION 015100 - TEMPORARY INDOOR AIR QUALITY CONTROLS

PART 1 GENERAL

1.1 SUMMARY

A. Section Includes:

1. HVAC air filters.
2. Indoor air quality testing.

1.2 PLAN REQUIREMENTS

A. Intent:

1. Prevent indoor air quality problems resulting from the construction process.
2. Protect HVAC system during construction, control pollutant sources and interrupt contamination pathways.

1.3 SUBMITTALS

- A. Product Data: Submit description and performance data for filters, including MERV ratings.

1.4 SEQUENCING

- A. Sequence material delivery and installation to avoid exposing insulation, carpeting, acoustical ceilings, gypsum board and other absorptive materials to contamination and moisture.
1. Enclose building before storing and installing moisture sensitive products within building under construction.

PART 2 PRODUCTS

2.1 HVAC AIR FILTERS

- A. Return Filters: Filtration media rated for minimum efficiency reporting value (MERV) when tested in accordance with ASHRAE 52.2.
1. Construction Return Filters: MERV of 8, minimum.
 2. Flush-Out Return Filters: MERV of 13, minimum.
 3. Permanent Filters: MERV of 13, minimum.
- B. Supply Filters: As specified in Division 15.

PART 3 EXECUTION

3.1 FILTER INSTALLATION AND REPLACEMENT

- A. Install construction return filter at each return grille before operating permanent air handlers during construction.
- B. Replace filters after completing construction and before occupancy.

3.2 FIELD QUALITY CONTROL

- A. Conduct baseline indoor air quality testing procedure in accordance with EPA 600-4-90-010.
 - 1. Verify indoor air contaminates do not exceed the following limits:

Contaminate	Maximum Concentration
Formaldehyde	50 parts per billion
Particulates (PM10)	50 micrograms per cubic meter
Total Volatile Organic Compounds (TVOC)	500 micrograms per cubic meter
4-Phenylcyclohexene (4-PCH)	6.5 micrograms per cubic meter
Carbon Monoxide (CO)	9 part per million and no greater than 2 parts per million above outdoor levels

- B. Conduct air sample testing in accordance with the following:
 - 1. Verify interior finishes including but not limited to millwork, doors, paint, carpet and acoustic tiles are installed. Verify movable furnishings such as workstations and partitions are installed.
 - 2. Test air quality before occupancy, during normal occupied hours, with building ventilation system starting at normal daily start time and operated at minimum outside air flow rate for occupied mode for duration of air testing.
 - 3. Test air quality for each portion of building served by separate ventilation system, using minimum one sampling point for each contiguous floor area. Include sampling points in areas with least ventilation and greatest presumed contaminate source strength as directed by Owner and Architect.
 - 4. Collect air samples between 3 and 6 feet above finished floor. Collect samples over minimum 4-hour period.
- C. When tests indicate contaminates exceed maximum concentration limit, flush affected building area with outside air and retest.
 - 1. Repeat flushing and retesting until measured contaminate concentrations are less than specified maximum limits.

2. Take air samples for retests at same location as initial tests.

END OF SECTION 015100

THIS PAGE INTENTIONALLY LEFT BLANK

Copyright 2013 by The American Institute of Architects (AIA)

SECTION 015639 - TEMPORARY TREE AND PLANT PROTECTION

PART 1 - GENERAL

1.1 RELATED DOCUMENTS

- A. Drawings and general provisions of the Contract, including General and Supplementary Conditions and Division 01 Specification Sections, apply to this Section.

1.2 SUMMARY

- A. Section includes general protection and pruning of existing trees and plants that are affected by execution of the Work, whether temporary or permanent construction.
- B. Related Requirements:
 - 1. Section 015000 "Temporary Facilities and Controls" for temporary site fencing.
 - 2. Section 311000 "Site Clearing" for removing existing trees and shrubs.

1.3 DEFINITIONS

- A. Caliper: Diameter of a trunk measured by the average of the smallest and largest diameters at a height 6 inches (150 mm) above the ground for trees up to and including 4-inch (100-mm) size at this height and as measured at a height of 12 inches (300 mm) above the ground for trees larger than 4-inch (100-mm) size.
- B. Plant-Protection Zone: Area surrounding individual trees, groups of trees, shrubs, or other vegetation to be protected during construction and indicated on Drawings.
- C. Tree-Protection Zone: Area surrounding individual trees or groups of trees to be protected during construction and defined by a circle concentric with each tree with a radius 1.5 times the diameter of the drip line unless otherwise indicated.
- D. Vegetation: Trees, shrubs, groundcovers, grass, and other plants.

1.4 PREINSTALLATION MEETINGS

- A. Preinstallation Conference: Conduct conference at Project site.
 - 1. Review methods and procedures related to temporary tree and plant protection including, but not limited to, the following:
 - a. Tree-service firm's personnel, and equipment needed to make progress and avoid delays.

- b. Arborist's responsibilities.
- c. Quality-control program.
- d. Coordination of Work and equipment movement with the locations of protection zones.
- e. Trenching by hand or with air spade within protection zones.
- f. Field quality control.

1.5 ACTION SUBMITTALS

- A. Product Data: For each type of product.
- B. Shop Drawings:
 1. Include plans, elevations, sections, and locations of protection-zone fencing and signage, showing relation of equipment-movement routes and material storage locations with protection zones.
 2. Detail fabrication and assembly of protection-zone fencing and signage.
 3. Indicate extent of trenching by hand or with air spade within protection zones.
- C. Samples: For each type of the following:
 1. Organic Mulch: 1-pint (0.5-L) volume of organic mulch; in sealed plastic bags labeled with composition of materials by percentage of weight and source of mulch.
 2. Protection-Zone Fencing: Assembled Samples of manufacturer's standard size made from full-size components.
 3. Protection-Zone Signage: Full-size Samples of each size and text, ready for installation.
- D. Qualification Data: For arborist and tree service firm.
- E. Certification: From arborist, certifying that trees indicated to remain have been protected during construction according to recognized standards and that trees were promptly and properly treated and repaired when damaged.
- F. Maintenance Recommendations: From arborist, for care and protection of trees affected by construction during and after completing the Work.
- G. Existing Conditions: Documentation of existing trees and plantings indicated to remain, which establishes preconstruction conditions that might be misconstrued as damage caused by construction activities.
 1. Use sufficiently detailed photographs or video recordings.
 2. Include plans and notations to indicate specific wounds and damage conditions of each tree or other plants designated to remain.
- H. Quality-control program.

1.6 QUALITY ASSURANCE

- A. Arborist Qualifications: Licensed arborist in jurisdiction where Project is located.

- B. Tree Service Firm Qualifications: An experienced tree service firm that has successfully completed temporary tree and plant protection work similar to that required for this Project and that will assign an experienced, qualified arborist to Project site during execution of the Work.
- C. Quality-Control Program: Prepare a written program to systematically demonstrate the ability of personnel to properly follow procedures and handle materials and equipment during the Work without damaging trees and plantings. Include dimensioned diagrams for placement of protection zone fencing and signage, the arborist's and tree-service firm's responsibilities, instructions given to workers on the use and care of protection zones, and enforcement of requirements for protection zones.

1.7 FIELD CONDITIONS

- A. The following practices are prohibited within protection zones:
 - 1. Storage of construction materials, debris, or excavated material.
 - 2. Moving or parking vehicles or equipment.
 - 3. Foot traffic.
 - 4. Erection of sheds or structures.
 - 5. Impoundment of water.
 - 6. Excavation or other digging unless otherwise indicated.
 - 7. Attachment of signs to or wrapping materials around trees or plants unless otherwise indicated.
- B. Do not direct vehicle or equipment exhaust toward protection zones.
- C. Prohibit heat sources, flames, ignition sources, and smoking within or near protection zones and organic mulch.

PART 2 - PRODUCTS

2.1 MATERIALS

- A. Backfill Soil: Stockpiled soil mixed with planting soil of suitable moisture content and granular texture for placing around tree; free of stones, roots, plants, sod, clods, clay lumps, pockets of coarse sand, concrete slurry, concrete layers or chunks, cement, plaster, building debris, and other extraneous materials harmful to plant growth.
 - 1. Mixture: Well-blended mix of two parts stockpiled soil to one part planting soil.
- B. Organic Mulch: Free from deleterious materials and suitable as a top dressing for trees and shrubs, consisting of one of the following:
 - 1. Type: Shredded hardwood.
 - 2. Size Range: 3 inches (76 mm) maximum, 1/2 inch (13 mm) minimum.
 - 3. Color: Natural.

- C. Protection-Zone Fencing: Fencing fixed in position and meeting one of the following requirements:
1. Chain-Link Protection-Zone Fencing: Galvanized-steel fencing fabricated from minimum 2-inch (50-mm) opening, 0.148-inch- (3.76-mm-) diameter wire chain-link fabric; with pipe posts, minimum 2-3/8-inch- (60-mm-) OD line posts, and 2-7/8-inch- (73-mm-) OD corner and pull posts; with 1-5/8-inch- (42-mm-) OD top rails and 0.177-inch- (4.5-mm-) diameter bottom tension wire; with tie wires, hog ring ties, and other accessories for a complete fence system.
 - a. Height: 72 inches (1800 mm).
 2. Gates: Single- swing access gates matching material and appearance of fencing, to allow for maintenance activities within protection zones; leaf width 36 inches (914 mm).

PART 3 - EXECUTION

3.1 EXAMINATION

- A. Erosion and Sedimentation Control: Examine the site to verify that temporary erosion- and sedimentation-control measures are in place. Verify that flows of water redirected from construction areas or generated by construction activity do not enter or cross protection zones.
- B. Prepare written report, endorsed by arborist, listing conditions detrimental to tree and plant protection.

3.2 PREPARATION

- A. Locate and clearly identify trees, shrubs, and other vegetation to remain. Tie a 1-inch (25-mm) blue vinyl tape around each tree trunk at 54 inches (1372 mm) above the ground.
- B. Protect tree root systems from damage caused by runoff or spillage of noxious materials while mixing, placing, or storing construction materials. Protect root systems from ponding, eroding, or excessive wetting caused by dewatering operations.
- C. Tree-Protection Zones: Mulch areas inside tree-protection zones and other areas indicated. Do not exceed indicated thickness of mulch.
 1. Apply 4-inch (100-mm) uniform thickness of organic mulch unless otherwise indicated. Do not place mulch within 6 inches (150 mm) of tree trunks.

3.3 PROTECTION ZONES

- A. Protection-Zone Fencing: Install protection-zone fencing along edges of protection zones before materials or equipment are brought on the site and construction operations begin in a manner that will prevent people and animals from easily entering protected areas except by entrance gates. Construct fencing so as not to obstruct safe passage or visibility at vehicle intersections

where fencing is located adjacent to pedestrian walkways or in close proximity to street intersections, drives, or other vehicular circulation.

1. Chain-Link Fencing: Install to comply with ASTM F 567 and with manufacturer's written instructions.
2. Posts: Set or drive posts into ground one-third the total height of the fence without concrete footings. Where a post is located on existing paving or concrete to remain, provide appropriate means of post support acceptable to Architect.
3. Access Gates: Install where indicated; adjust to operate smoothly, easily, and quietly; free of binding, warp, excessive deflection, distortion, nonalignment, misplacement, disruption, or malfunction throughout entire operational range. Confirm that latches and locks engage accurately and securely without forcing or binding.

B. Maintain protection zones free of weeds and trash.

C. Maintain protection-zone fencing in good condition as acceptable to Architect and remove when construction operations are complete and equipment has been removed from the site.

1. Do not remove protection-zone fencing, even temporarily, to allow deliveries or equipment access through the protection zone.
2. Temporary access is permitted subject to preapproval in writing by arborist if a root buffer effective against soil compaction is constructed as directed by arborist. Maintain root buffer so long as access is permitted.

3.4 EXCAVATION

A. General: Excavate at edge of protection zones and for trenches indicated within protection zones according to requirements in Section 312000 "Earth Moving" unless otherwise indicated.

B. Trenching within Protection Zones: Where utility trenches are required within protection zones, excavate under or around tree roots by hand or with air spade, or tunnel under the roots by drilling, auger boring, or pipe jacking. Do not cut main lateral tree roots or taproots; cut only smaller roots that interfere with installation of utilities. Cut roots as required for root pruning. If excavating by hand, use narrow-tine spading forks to comb soil and expose roots.

C. Redirect roots in backfill areas where possible. If encountering large, main lateral roots, expose roots beyond excavation limits as required to bend and redirect them without breaking. If encountered immediately adjacent to location of new construction and redirection is not practical, cut roots approximately 3 inches (75 mm) back from new construction and as required for root pruning.

D. Do not allow exposed roots to dry out before placing permanent backfill. Provide temporary earth cover or pack with peat moss and wrap with burlap. Water and maintain in a moist condition. Temporarily support and protect roots from damage until they are permanently relocated and covered with soil.

3.5 REGRADING

- A. Lowering Grade: Where new finish grade is indicated below existing grade around trees, slope grade beyond the protection zone. Maintain existing grades within the protection zone.
- B. Lowering Grade within Protection Zone: Where new finish grade is indicated below existing grade around trees, slope grade away from trees as recommended by arborist unless otherwise indicated.
 - 1. Root Pruning: Prune tree roots exposed by lowering the grade. Do not cut main lateral roots or taproots; cut only smaller roots. Cut roots as required for root pruning.
- C. Raising Grade: Where new finish grade is indicated above existing grade around trees, slope grade beyond the protection zone. Maintain existing grades within the protection zone.
- D. Minor Fill within Protection Zone: Where existing grade is 2 inches (50 mm) or less below elevation of finish grade, fill with backfill soil. Place backfill soil in a single uncompacted layer and hand grade to required finish elevations.

3.6 FIELD QUALITY CONTROL

- A. Inspections: Engage a qualified arborist to direct plant-protection measures in the vicinity of trees, shrubs, and other vegetation indicated to remain and to prepare inspection reports.

3.7 REPAIR AND REPLACEMENT

- A. General: Repair or replace trees, shrubs, and other vegetation indicated to remain or to be relocated that are damaged by construction operations, in a manner approved by Architect.
 - 1. Submit details of proposed pruning and repairs.
 - 2. Perform repairs of damaged trunks, branches, and roots within 24 hours according to arborist's written instructions.
 - 3. Replace trees and other plants that cannot be repaired and restored to full-growth status, as determined by Architect.
- B. Trees: Remove and replace trees indicated to remain that are more than 25 percent dead or in an unhealthy condition before the end of the corrections period or are damaged during construction operations that Architect determines are incapable of restoring to normal growth pattern.
 - 1. Small Trees: Provide new trees of same size and species as those being replaced for each tree that measures 4 inches (100 mm) or smaller in caliper size.
 - 2. Large Trees: Provide one new tree(s) of 6-inch (150-mm) caliper size for each tree being replaced that measures more than 6 inches (150 mm) in caliper size.
 - a. Species: As selected by Architect.
 - 3. Plant and maintain new trees as specified in Section 329300 "Plants."

- C. Excess Mulch: Rake mulched area within protection zones, being careful not to injure roots. Rake to loosen and remove mulch that exceeds a 4-inch (100-mm) uniform thickness to remain.
- D. Soil Aeration: Where directed by Architect, aerate surface soil compacted during construction. Aerate 10 feet (3 m) beyond drip line and no closer than 36 inches (900 mm) to tree trunk. Drill 2-inch- (50-mm-) diameter holes a minimum of 12 inches (300 mm) deep at 24 inches (600 mm) o.c. Backfill holes with an equal mix of augered soil and sand.

3.8 DISPOSAL OF SURPLUS AND WASTE MATERIALS

- A. Disposal: Remove excess excavated material, displaced trees, trash, and debris and legally dispose of them off Owner's property.

END OF SECTION 015639

THIS PAGE INTENSIONALLY LEFT BLANK

Copyright 2015 by The American Institute of Architects (AIA)

SECTION 016000 - PRODUCT REQUIREMENTS

PART 1 - GENERAL

1.1 RELATED DOCUMENTS

- A. Drawings and general provisions of the Contract, including General and Supplementary Conditions and other Division 01 Specification Sections, apply to this Section.

1.2 SUMMARY

- A. Section includes administrative and procedural requirements for selection of products for use in Project; product delivery, storage, and handling; manufacturers' standard warranties on products; special warranties; and comparable products.
- B. Related Requirements:
 - 1. Section 014200 "References" for applicable industry standards for products specified.

1.3 DEFINITIONS

- A. Products: Items obtained for incorporating into the Work, whether purchased for Project or taken from previously purchased stock. The term "product" includes the terms "material," "equipment," "system," and terms of similar intent.
 - 1. Named Products: Items identified by manufacturer's product name, including make or model number or other designation shown or listed in manufacturer's published product literature that is current as of date of the Contract Documents.
 - 2. New Products: Items that have not previously been incorporated into another project or facility. Products salvaged or recycled from other projects are not considered new products.
 - 3. Comparable Product: Product that is demonstrated and approved by Architect through submittal process to have the indicated qualities related to type, function, dimension, in-service performance, physical properties, appearance, and other characteristics that equal or exceed those of specified product.
- B. Basis-of-Design Product Specification: A specification in which a single manufacturer's product is named and accompanied by the words "basis-of-design product," including make or model number or other designation. In addition to the basis-of-design product description, product attributes and characteristics may be listed to establish the significant qualities related to type, function, in-service performance and physical properties, weight, dimension, durability, visual characteristics, and other special features and requirements for purposes of evaluating comparable products of additional manufacturers named in the specification.

- C. Subject to Compliance with Requirements: Where the phrase "Subject to compliance with requirements" introduces a product selection procedure in an individual Specification Section, provide products qualified under the specified product procedure. In the event that a named product or product by a named manufacturer does not meet the other requirements of the specifications, select another named product or product from another named manufacturer that does meet the requirements of the specifications. Submit a comparable product request, if applicable.
- D. Substitutions: Requests for changes in products, materials, equipment, and methods of construction required by Contract Documents proposed by the Contractor after award of the Contract are considered requests for "substitutions." The following are not considered substitutions:
 - 1. Substitutions requested by Bidders during the bidding period, and accepted prior to award of Contract, are considered as included in the Contract Documents and are not subject to requirements specified in this Section for substitutions.
 - 2. Revisions to Contract Documents requested by the Owner or A/E.
 - 3. Specified options of products and construction methods included in Contract Documents.
 - 4. The Contractor's determination of and compliance with governing regulations and orders issued by governing authorities.

1.4 ACTION SUBMITTALS

- A. Comparable Product Request Submittal: Submit request for consideration of each comparable product. Identify basis-of-design product or fabrication or installation method to be replaced. Include Specification Section number and title and Drawing numbers and titles.
 - 1. Include data to indicate compliance with the requirements specified in "Comparable Products" Article.
 - 2. Architect's Action: If necessary, Architect will request additional information or documentation for evaluation within seven days of receipt of a comparable product request. Architect will notify Contractor of approval or rejection of proposed comparable product request within 15 days of receipt of request, or seven days of receipt of additional information or documentation, whichever is later.
 - a. Form of Architect's Approval of Submittal: As specified in Section 013300 "Submittal Procedures."
 - b. Use product specified if Architect does not issue a decision on use of a comparable product request within time allocated.
- B. Basis-of-Design Product Specification Submittal: Comply with requirements in Section 013300 "Submittal Procedures." Show compliance with requirements.

1.5 QUALITY ASSURANCE

- A. Compatibility of Options: If Contractor is given option of selecting between two or more products for use on Project, select product compatible with products previously selected, even if previously selected products were also options.

- B. Identification of Products: Except for required labels and operating data, do not attach or imprint manufacturer or product names or trademarks on exposed surfaces of products or equipment that will be exposed to view in occupied spaces or on the exterior.
1. Labels: Locate required product labels and stamps on a concealed surface, or, where required for observation following installation, on a visually accessible surface that is not conspicuous.
 2. Equipment Nameplates: Provide a permanent nameplate on each item of service-connected or power-operated equipment. Locate on a visually accessible but inconspicuous surface. Include information essential for operation, including the following:
 - a. Name of product and manufacturer.
 - b. Model and serial number.
 - c. Capacity.
 - d. Speed.
 - e. Ratings.
 3. See individual identification sections in Divisions 21, 22, 23, and 26 for additional identification requirements.

1.6 PRODUCT DELIVERY, STORAGE, AND HANDLING

- A. Deliver, store, and handle products using means and methods that will prevent damage, deterioration, and loss, including theft and vandalism. Comply with manufacturer's written instructions.
- B. Delivery and Handling:
1. Schedule delivery to minimize long-term storage at Project site and to prevent overcrowding of construction spaces.
 2. Coordinate delivery with installation time to ensure minimum holding time for items that are flammable, hazardous, easily damaged, or sensitive to deterioration, theft, and other losses.
 3. Deliver products to Project site in an undamaged condition in manufacturer's original sealed container or other packaging system, complete with labels and instructions for handling, storing, unpacking, protecting, and installing.
 4. Inspect products on delivery to determine compliance with the Contract Documents and to determine that products are undamaged and properly protected.
- C. Storage:
1. Store products to allow for inspection and measurement of quantity or counting of units.
 2. Store materials in a manner that will not endanger Project structure.
 3. Store products that are subject to damage by the elements, under cover in a weathertight enclosure above ground, with ventilation adequate to prevent condensation.
 4. Protect foam plastic from exposure to sunlight, except to extent necessary for period of installation and concealment.
 5. Comply with product manufacturer's written instructions for temperature, humidity, ventilation, and weather-protection requirements for storage.

6. Protect stored products from damage and liquids from freezing.

1.7 PRODUCT WARRANTIES

- A. Warranties specified in other Sections shall be in addition to, and run concurrent with, other warranties required by the Contract Documents. Manufacturer's disclaimers and limitations on product warranties do not relieve Contractor of obligations under requirements of the Contract Documents.
 1. Manufacturer's Warranty: Written warranty furnished by individual manufacturer for a particular product and specifically endorsed by manufacturer to Owner.
 2. Special Warranty: Written warranty required by the Contract Documents to provide specific rights for Owner.
- B. Special Warranties: Prepare a written document that contains appropriate terms and identification, ready for execution.
 1. Manufacturer's Standard Form: Modified to include Project-specific information and properly executed.
 2. Specified Form: When specified forms are included with the Specifications, prepare a written document using indicated form properly executed.
 3. See other Sections for specific content requirements and particular requirements for submitting special warranties.
- C. Submittal Time: Comply with requirements in Section 017700 "Closeout Procedures."

PART 2 - PRODUCTS

2.1 PRODUCT SELECTION PROCEDURES

- A. General Product Requirements: Provide products that comply with the Contract Documents, are undamaged and, unless otherwise indicated, are new at time of installation.
 1. Provide products complete with accessories, trim, finish, fasteners, and other items needed for a complete installation and indicated use and effect.
 2. Standard Products: If available, and unless custom products or nonstandard options are specified, provide standard products of types that have been produced and used successfully in similar situations on other projects.
 3. Owner reserves the right to limit selection to products with warranties meeting requirements of the Contract Documents.
 4. Where products are accompanied by the term "as selected," Architect will make selection.
 5. Descriptive, performance, and reference standard requirements in the Specifications establish salient characteristics of products.
 6. Or Equal: For products specified by name and accompanied by the term "or equal," or "or approved equal," or "or approved," comply with requirements in "Comparable Products" Article to obtain approval for use of an unnamed product.

- a. Submit additional documentation required by Architect in order to establish equivalency of proposed products. Evaluation of "or equal" product status is by the Architect; whose determination is final.
- B. Product Selection Procedures:
1. Sole Product: Where Specifications name a single manufacturer and product, provide the named product that complies with requirements. Comparable products or substitutions for Contractor's convenience will not be considered.
 - a. Sole product may be indicated by the phrase: "Subject to compliance with requirements, provide the following: ..."
 2. Sole Manufacturer/Source: Where Specifications name a single manufacturer or source, provide a product by the named manufacturer or source that complies with requirements. Comparable products or substitutions for Contractor's convenience will not be considered.
 - a. Sole manufacturer/source may be indicated by the phrase: "Subject to compliance with requirements, provide products by the following: ..."
 3. Limited List of Products: Where Specifications include a list of names of both manufacturers and products, provide one of the products listed that complies with requirements. Comparable products or substitutions for Contractor's convenience will not be considered.
 - a. Limited list of products may be indicated by the phrase: "Subject to compliance with requirements, provide one of the following: ..."
 4. Non-Limited List of Products: Where Specifications include a list of names of both available manufacturers and products, provide one of the products listed, or an unnamed product, which complies with requirements.
 - a. Non-limited list of products is indicated by the phrase: "Subject to compliance with requirements, available products that may be incorporated in the Work include, but are not limited to, the following: ..."
 5. Limited List of Manufacturers: Where Specifications include a list of manufacturers' names, provide a product by one of the manufacturers listed that complies with requirements. Comparable products or substitutions for Contractor's convenience will not be considered.
 - a. Limited list of manufacturers is indicated by the phrase: "Subject to compliance with requirements, provide products by one of the following: ..."
 6. Non-Limited List of Manufacturers: Where Specifications include a list of available manufacturers, provide a product by one of the manufacturers listed, or a product by an unnamed manufacturer, which complies with requirements.

-
- a. Non-limited list of manufacturers is indicated by the phrase: "Subject to compliance with requirements, available manufacturers whose products may be incorporated in the Work include, but are not limited to, the following: ..."
7. Basis-of-Design Product: Where Specifications name a product, or refer to a product indicated on Drawings, and include a list of manufacturers, provide the specified or indicated product or a comparable product by one of the other named manufacturers. Drawings and Specifications indicate sizes, profiles, dimensions, and other characteristics that are based on the product named. Comply with requirements in "Comparable Products" Article for consideration of an unnamed product by one of the other named manufacturers.
 - a. For approval of products by unnamed manufacturers, comply with requirements in Section 012500 "Substitution Procedures" for substitutions for convenience.
- C. Visual Matching Specification: Where Specifications require "match Architect's sample," provide a product that complies with requirements and matches Architect's sample. Architect's decision will be final on whether a proposed product matches.
 1. If no product available within specified category matches and complies with other specified requirements, comply with requirements in Section 012500 "Substitution Procedures" for proposal of product.
 - D. Visual Selection Specification: Where Specifications include the phrase "as selected by Architect from manufacturer's full range" or similar phrase, select a product that complies with requirements. Architect will select color, gloss, pattern, density, or texture from manufacturer's product line that includes both standard and premium items.
- ## 2.2 COMPARABLE PRODUCTS
- A. Conditions for Consideration of Comparable Products: Architect will consider Contractor's request for comparable product when the following conditions are satisfied. If the following conditions are not satisfied, Architect may return requests without action, except to record noncompliance with these requirements:
 1. Evidence that proposed product does not require revisions to the Contract Documents, is consistent with the Contract Documents, will produce the indicated results, and is compatible with other portions of the Work. Detailed comparison of significant qualities of proposed product with those named in the Specifications. Significant product qualities include attributes such as type, function, in-service performance and physical properties, weight, dimension, durability, visual characteristics, and other specific features and requirements.
 2. Evidence that proposed product provides specified warranty.
 3. List of similar installations for completed projects with project names and addresses and names and addresses of architects and owners, if requested.
 4. Samples, if requested.
 - B. Submittal Requirements: Approval by the Architect of Contractor's request for use of comparable product is not intended to satisfy other submittal requirements. Comply with specified submittal requirements.

PART 3 - EXECUTION (Not Used)

END OF SECTION 016000

THIS PAGE INTENSIONALLY LEFT BLANK

Copyright 2016 by The American Institute of Architects (AIA)

SECTION 017419 - CONSTRUCTION WASTE MANAGEMENT AND DISPOSAL

PART 1 - GENERAL

1.1 RELATED DOCUMENTS

- A. Drawings and general provisions of the Contract, including General and Supplementary Conditions and other Division 01 Specification Sections, apply to this Section.

1.2 SUMMARY

- A. Section includes administrative and procedural requirements for the following:
 - 1. Salvaging nonhazardous demolition and construction waste.
 - 2. Recycling nonhazardous demolition and construction waste.
 - 3. Disposing of nonhazardous demolition and construction waste.
- B. Related Requirements:
 - 1. Section 042000 "Unit Masonry" for disposal requirements for masonry waste.
 - 2. Section 311000 "Site Clearing" for disposition of waste resulting from site clearing and removal of above- and below-grade improvements.

1.3 DEFINITIONS

- A. Construction Waste: Building, structure, and site improvement materials and other solid waste resulting from construction, remodeling, renovation, or repair operations. Construction waste includes packaging.
- B. Demolition Waste: Building, structure, and site improvement materials resulting from demolition operations.
- C. Disposal: Removal of demolition or construction waste and subsequent salvage, sale, recycling, or deposit in landfill, incinerator acceptable to authorities having jurisdiction, or designated spoil areas on Owner's property.
- D. Recycle: Recovery of demolition or construction waste for subsequent processing in preparation for reuse.
- E. Salvage: Recovery of demolition or construction waste and subsequent sale or reuse in another facility.
- F. Salvage and Reuse: Recovery of demolition or construction waste and subsequent incorporation into the Work.

1.4 MATERIALS OWNERSHIP

- A. Unless otherwise indicated, demolition and construction waste become property of Contractor.
- B. Historic items, relics, antiques, and similar objects including, but not limited to, cornerstones and their contents, commemorative plaques and tablets, and other items of interest or value to the County that may be uncovered during demolition remain the property of the County.
 - 1. Carefully salvage in a manner to prevent damage and promptly return to the County.

1.5 ACTION SUBMITTALS

- A. Waste Management Plan: Submit plan within 30 days of date established for the Notice to Proceed.

1.6 INFORMATIONAL SUBMITTALS

- A. Waste Reduction Progress Reports: Concurrent with each Application for Payment, submit report. Use Form CWM-7 for construction waste and Form CWM-8 for demolition waste. Include the following information:
 - 1. Material category.
 - 2. Generation points of waste.
 - 3. Total quantity of waste in tons.
 - 4. Quantity of waste salvaged, both estimated and actual in tons.
 - 5. Quantity of waste recycled, both estimated and actual in tons.
 - 6. Total quantity of waste recovered (salvaged plus recycled) in tons.
 - 7. Total quantity of waste recovered (salvaged plus recycled) as a percentage of total waste.
- B. Waste Reduction Calculations: Before request for Substantial Completion, submit calculated end-of-Project rates for salvage, recycling, and disposal as a percentage of total waste generated by the Work.
- C. Recycling and Processing Facility Records: Indicate receipt and acceptance of recyclable waste by recycling and processing facilities licensed to accept them. Include manifests, weight tickets, receipts, and invoices.
- D. Landfill and Incinerator Disposal Records: Indicate receipt and acceptance of waste by landfills and incinerator facilities licensed to accept them. Include manifests, weight tickets, receipts, and invoices.
- E. Qualification Data: For waste management coordinator and refrigerant recovery technician.
- F. Statement of Refrigerant Recovery: Signed by refrigerant recovery technician responsible for recovering refrigerant, stating that all refrigerant that was present was recovered and that recovery was performed according to EPA regulations. Include name and address of technician and date refrigerant was recovered.

- G. Refrigerant Recovery: Comply with requirements in Section 024119 "Selective Demolition" for refrigerant recovery submittals.

1.7 QUALITY ASSURANCE

- A. Waste Management Coordinator Qualifications: Experienced firm, or individual employed and assigned by General Contractor, with a record of successful waste management coordination of projects with similar requirements. Superintendent may serve as Waste Management Coordinator.
- B. Refrigerant Recovery Technician Qualifications: Comply with requirements in Section 024119 "Selective Demolition."
- C. Regulatory Requirements: Comply with transportation and disposal regulations of authorities having jurisdiction.
- D. Waste Management Conference(s): Conduct conference(s) at Project site to comply with requirements in Section 013100 "Project Management and Coordination." Review methods and procedures related to waste management including, but not limited to, the following:
 - 1. Review and discuss waste management plan including responsibilities of each contractor and waste management coordinator.
 - 2. Review requirements for documenting quantities of each type of waste and its disposition.
 - 3. Review and finalize procedures for materials separation and verify availability of containers and bins needed to avoid delays.
 - 4. Review procedures for periodic waste collection and transportation to recycling and disposal facilities.
 - 5. Review waste management requirements for each trade.

1.8 WASTE MANAGEMENT PLAN

- A. General: Develop a waste management plan according to requirements in this Section. Plan shall consist of waste identification, waste reduction work plan, and cost/revenue analysis. Distinguish between demolition and construction waste. Indicate quantities by weight or volume but use same units of measure throughout waste management plan.
- B. Waste Identification: Indicate anticipated types and quantities of demolition and construction waste generated by the Work. Use Form CWM-1 for construction waste and Form CWM-2 for demolition waste. Include estimated quantities and assumptions for estimates.
- C. Waste Reduction Work Plan: List each type of waste and whether it will be salvaged, recycled, or disposed of in landfill or incinerator. Use Form CWM-3 for construction waste and Form CWM-4 for demolition waste. Include points of waste generation, total quantity of each type of waste, quantity for each means of recovery, and handling and transportation procedures.
 - 1. Salvaged Materials for Reuse: For materials that will be salvaged and reused in this Project, describe methods for preparing salvaged materials before incorporation into the Work in compliance with Section 024119 "Selective Demolition."

2. Salvaged Materials for Sale: For materials that will be sold to individuals and organizations, include list of their names, addresses, and telephone numbers.
 3. Recycled Materials: Include list of local receivers and processors and type of recycled materials each will accept. Include names, addresses, and telephone numbers.
 4. Disposed Materials: Indicate how and where materials will be disposed of. Include name, address, and telephone number of each landfill and incinerator facility.
 5. Handling and Transportation Procedures: Include method that will be used for separating recyclable waste including sizes of containers, container labeling, and designated location where materials separation will be performed.
- D. Cost/Revenue Analysis: Indicate total cost of waste disposal as if there were no waste management plan and net additional cost or net savings resulting from implementing waste management plan. Use Form CWM-5 for construction waste and Form CWM-6 for demolition waste. Include the following:
1. Total quantity of waste.
 2. Estimated cost of disposal (cost per unit). Include transportation and tipping fees and cost of collection containers and handling for each type of waste.
 3. Total cost of disposal (with no waste management).
 4. Revenue from salvaged materials.
 5. Revenue from recycled materials.
 6. Savings in transportation and tipping fees by donating materials.
 7. Savings in transportation and tipping fees that are avoided.
 8. Handling and transportation costs. Include cost of collection containers for each type of waste.
 9. Net additional cost or net savings from waste management plan.

PART 2 - PRODUCTS

2.1 PERFORMANCE REQUIREMENTS

- A. General: Achieve end-of-Project rates for salvage/recycling of 50 percent by weight of total nonhazardous solid waste generated by the Work. Practice efficient waste management in the use of materials in the course of the Work. Use all reasonable means to divert construction and demolition waste from landfills and incinerators. Facilitate recycling and salvage of materials, including the following:
1. Demolition Waste:
 - a. Asphalt paving.
 - b. Concrete.
 - c. Concrete reinforcing steel.
 - d. Brick.
 - e. Concrete masonry units.
 - f. Wood studs.
 - g. Wood joists.
 - h. Plywood and oriented strand board.
 - i. Wood paneling.
 - j. Wood trim.

- k. Structural and miscellaneous steel.
- l. Rough hardware.
- m. Roofing.
- n. Insulation.
- o. Doors and frames.
- p. Door hardware.
- q. Windows.
- r. Glazing.
- s. Metal studs.
- t. Gypsum board.
- u. Acoustical tile and panels.
- v. Carpet.
- w. Carpet pad.
- x. Demountable partitions.
- y. Equipment.
- z. Cabinets.
- aa. Plumbing fixtures.
- bb. Piping.
- cc. Supports and hangers.
- dd. Valves.
- ee. Sprinklers.
- ff. Mechanical equipment.
- gg. Refrigerants.
- hh. Electrical conduit.
- ii. Copper wiring.
- jj. Lighting fixtures.
- kk. Lamps.
- ll. Ballasts.
- mm. Electrical devices.
- nn. Switchgear and panelboards.
- oo. Transformers.

2. Construction Waste:

- a. Masonry and CMU.
- b. Lumber.
- c. Wood sheet materials.
- d. Wood trim.
- e. Metals.
- f. Roofing.
- g. Insulation.
- h. Carpet and pad.
- i. Gypsum board.
- j. Piping.
- k. Electrical conduit.
- l. Packaging: Regardless of salvage/recycle goal indicated in "General" Paragraph above, salvage or recycle 100 percent of the following uncontaminated packaging materials:
 - 1) Paper.
 - 2) Cardboard.

- 3) Boxes.
 - 4) Plastic sheet and film.
 - 5) Polystyrene packaging.
 - 6) Wood crates.
 - 7) Wood pallets.
 - 8) Plastic pails.
- m. Construction Office Waste: Regardless of salvage/recycle goal indicated in "General" Paragraph above, salvage or recycle 100 percent of the following construction office waste materials:
- 1) Paper.
 - 2) Aluminum cans.
 - 3) Glass containers.

PART 3 - EXECUTION

3.1 PLAN IMPLEMENTATION

- A. General: Implement approved waste management plan. Provide handling, containers, storage, signage, transportation, and other items as required to implement waste management plan during the entire duration of the Contract.
1. Comply with operation, termination, and removal requirements in Section 015000 "Temporary Facilities and Controls."
- B. Training: Train workers, subcontractors, and suppliers on proper waste management procedures, as appropriate for the Work.
1. Distribute waste management plan to everyone concerned within seven days of submittal return.
 2. Distribute waste management plan to entities when they first begin work on-site. Review plan procedures and locations established for salvage, recycling, and disposal.
- C. Site Access and Temporary Controls: Conduct waste management operations to ensure minimum interference with roads, streets, walks, walkways, and other adjacent occupied and used facilities.
1. Designate and label specific areas on Project site necessary for separating materials that are to be salvaged and recycled.
 2. Comply with Section 015000 "Temporary Facilities and Controls" for controlling dust and dirt, environmental protection, and noise control.

3.2 SALVAGING DEMOLITION WASTE

- A. Comply with requirements in Section 024119 "Selective Demolition" for salvaging demolition waste.

3.3 RECYCLING DEMOLITION AND CONSTRUCTION WASTE, GENERAL

- A. General: Recycle paper and beverage containers used by on-site workers.
- B. Recycling Incentives: Revenues, savings, rebates, tax credits, and other incentives received for recycling waste materials shall accrue to Owner.
- C. Preparation of Waste: Prepare and maintain recyclable waste materials according to recycling or reuse facility requirements. Maintain materials free of dirt, adhesives, solvents, petroleum contamination, and other substances deleterious to the recycling process.
- D. Procedures: Separate recyclable waste from other waste materials, trash, and debris. Separate recyclable waste by type at Project site to the maximum extent practical according to approved construction waste management plan.
 - 1. Provide appropriately marked containers or bins for controlling recyclable waste until removed from Project site. Include list of acceptable and unacceptable materials at each container and bin.
 - a. Inspect containers and bins for contamination and remove contaminated materials if found.
 - 2. Stockpile processed materials on-site without intermixing with other materials. Place, grade, and shape stockpiles to drain surface water. Cover to prevent windblown dust.
 - 3. Stockpile materials away from construction area. Do not store within drip line of remaining trees.
 - 4. Store components off the ground and protect from the weather.
 - 5. Remove recyclable waste from Owner's property and transport to recycling receiver or processor as often as required to prevent overfilling bins.

3.4 RECYCLING DEMOLITION WASTE

- A. Asphalt Paving: Break up and transport paving to asphalt-recycling facility.
- B. Concrete: Remove reinforcement and other metals from concrete and sort with other metals.
 - 1. Pulverize concrete to maximum 1-1/2-inch size.
- C. Masonry: Remove metal reinforcement, anchors, and ties from masonry and sort with other metals.
 - 1. Pulverize masonry to maximum 1-1/2-inch size.
 - 2. Clean and stack undamaged, whole masonry units on wood pallets.
- D. Wood Materials: Sort and stack members according to size, type, and length. Separate lumber, engineered wood products, panel products, and treated wood materials.
- E. Metals: Separate metals by type.

1. Structural Steel: Stack members according to size, type of member, and length.
 2. Remove and dispose of bolts, nuts, washers, and other rough hardware.
- F. Asphalt Shingle Roofing: Separate organic and glass-fiber asphalt shingles and felts. Remove and dispose of nails, staples, and accessories.
- G. Gypsum Board: Stack large clean pieces on wood pallets or in container and store in a dry location. Remove edge trim and sort with other metals. Remove and dispose of fasteners.
- H. Acoustical Ceiling Panels and Tile: Stack large clean pieces on wood pallets and store in a dry location.
- I. Metal Suspension System: Separate metal members, including trim and other metals from acoustical panels and tile, and sort with other metals.
- J. Carpet and Pad: Roll large pieces tightly after removing debris, trash, adhesive, and tack strips.
1. Store clean, dry carpet and pad in a closed container or trailer provided by carpet reclamation agency or carpet recycler.
- K. Carpet Tile: Remove debris, trash, and adhesive.
1. Stack tile on pallet and store clean, dry carpet in a closed container or trailer provided by carpet reclamation agency or carpet recycler.
- L. Piping: Reduce piping to straight lengths and store by material and size. Separate supports, hangers, valves, sprinklers, and other components by material and size.
- M. Conduit: Reduce conduit to straight lengths and store by material and size.
- N. Lamps: Separate lamps by type and store according to requirements in 40 CFR 273.

3.5 RECYCLING CONSTRUCTION WASTE

A. Packaging:

1. Cardboard and Boxes: Break down packaging into flat sheets. Bundle and store in a dry location.
2. Polystyrene Packaging: Separate and bag materials.
3. Pallets: As much as possible, require deliveries using pallets to remove pallets from Project site. For pallets that remain on-site, break down pallets into component wood pieces and comply with requirements for recycling wood.
4. Crates: Break down crates into component wood pieces and comply with requirements for recycling wood.

B. Wood Materials:

1. Clean Cut-Offs of Lumber: Grind or chip into small pieces.
2. Clean Sawdust: Bag sawdust that does not contain painted or treated wood.

- C. Gypsum Board: Stack large clean pieces on wood pallets or in container and store in a dry location.
- D. Paint: Seal containers and store by type.

3.6 DISPOSAL OF WASTE

- A. General: Except for items or materials to be salvaged or recycled, remove waste materials from Project site and legally dispose of them in a landfill or incinerator acceptable to authorities having jurisdiction.
 - 1. Except as otherwise specified, do not allow waste materials that are to be disposed of accumulate on-site.
 - 2. Remove and transport debris in a manner that will prevent spillage on adjacent surfaces and areas.
- B. General: Except for items or materials to be salvaged or recycled, remove waste materials and legally dispose of at designated spoil areas on Owner's property.
- C. Burning: Do not burn waste materials.

END OF SECTION 017419

THIS PAGE INTENSIONALLY LEFT BLANK

Copyright 2017 by The American Institute of Architects (AIA)

SECTION 017700 - CLOSEOUT PROCEDURES

PART 1 - GENERAL

1.1 RELATED DOCUMENTS

- A. Drawings and general provisions of the Contract, including General and Supplementary Conditions and other Division 01 Specification Sections, apply to this Section.

1.2 SUMMARY

- A. Section includes administrative and procedural requirements for contract closeout, including, but not limited to, the following:
 - 1. Substantial Completion procedures.
 - 2. Final completion procedures.
 - 3. Warranties.
 - 4. Final cleaning.
 - 5. Repair of the Work.
- B. Related Requirements:
 - 1. Section 013233 "Photographic Documentation" for submitting final completion construction photographic documentation.
 - 2. Section 017823 "Operation and Maintenance Data" for additional operation and maintenance manual requirements.
 - 3. Section 017839 "Project Record Documents" for submitting Record Drawings, Record Specifications, and Record Product Data.
 - 4. Section 017900 "Demonstration and Training" for requirements to train the Owner's maintenance personnel to adjust, operate, and maintain products, equipment, and systems.

1.3 ACTION SUBMITTALS

- A. Product Data: For each type of cleaning agent.
- B. Contractor's List of Incomplete Items: Initial submittal at Substantial Completion.
- C. Certified List of Incomplete Items: Final submittal at final completion.

1.4 CLOSEOUT SUBMITTALS

- A. Certificates of Release: From authorities having jurisdiction.

B. Certificate of Insurance: For continuing coverage.

C. Field Report: For pest control inspection.

1.5 MAINTENANCE MATERIAL SUBMITTALS (ATTIC STOCK SUBMITTAL)

A. Schedule of Maintenance Material Items: For maintenance material submittal items specified in other Sections.

1.6 SUBSTANTIAL COMPLETION PROCEDURES

A. Contractor's List of Incomplete Items: Prepare and submit a list of items to be completed and corrected (Contractor's punch list), indicating the value of each item on the list and reasons why the Work is incomplete.

B. Submittals Prior to Substantial Completion: Complete the following a minimum of 10 days prior to requesting inspection for determining date of Substantial Completion. List items below that are incomplete at time of request.

1. Certificates of Release: Obtain and submit releases from authorities having jurisdiction permitting Owner unrestricted use of the Work and access to services and utilities. Include trades' final inspections approval tickets, occupancy permits, operating certificates, and similar releases.
2. Submit closeout submittals specified in other Division 01 Sections, including project record documents, operation and maintenance manuals, damage or settlement surveys, property surveys, and similar final record information.
3. Submit closeout submittals specified in individual Sections, including specific warranties, workmanship bonds, maintenance service agreements, final certifications, and similar documents.
4. Submit maintenance material (attic stock) submittals specified in individual Sections, including tools, spare parts, extra materials, and similar items, and deliver to location designated by the County Project Officer. Label with manufacturer's name and model number, and stored in a sequential order based on the Specification table of content.
 - a. Schedule of Maintenance Material Items: Prepare and submit schedule of maintenance material submittal items, including name and quantity of each item and name and number of related Specification Section. Obtain County Project Officer's signature for receipt of submittals.
5. Submit testing, adjusting, and balancing records.
6. Submit sustainable design submittals if required for Viridiant Earthcraft Certification not previously submitted.
7. Submit changeover information related to County's occupancy, use, operation, and maintenance.

C. Before requesting inspection for certification of Substantial Completion, complete the following:

1. Submit six copies of applied repair product information, care, and warranties workmanship bonds, maintenance service agreements, final certifications, and similar documents for approval by the A/E of Record.
 2. Complete startup testing of systems and initial system commissioning (seasonal systems commissioning will occur in accordance with Specification Section 01815 "HVAC Commissioning").
 3. Digital copy of site plan and building drawings as approved by the Project Officer and receive written approval from the A/E of Record that the drawings are complete.
 4. Acceptance of HVAC system performance including Building Automation Controls by Arlington County Commissioning Authority.
 5. Instruct County's personnel in operation, adjustment, and maintenance of products, equipment, and systems as required by the Specifications.
 6. Submit operations and maintenance manuals and receive written approval from the A/E of Record that the manuals are complete.
 7. Submission of certificate of final inspection from city, county and/or state agencies in accord with applicable codes, laws and ordinances.
 8. The County's Project Officer will be securing any (partial or full) occupancy permits required by local authorities. The contractor shall obtain and submit releases permitting Owner unrestricted use of the Work and access to services and utilities.
 9. Perform the first final cleaning as described herein.
 10. Obtain inspection of fire protection system (sprinkler system) by the Fire Marshal's office and Owner's Insurance Rating Bureau plus correction of any deficiencies identified by Arlington County.
 11. Provide electrical systems fully operating, inspection and acceptance by appropriate authorities.
 12. All labeling shall be complete as required in the Specifications.
 13. All safety devices shall be fully operational.
 14. All pressure vessels must be inspected and approved by appropriate state and local authorities.
- D. Procedures Prior to Substantial Completion: Complete the following a minimum of 10 days prior to requesting inspection for determining date of Substantial Completion. List items below that are incomplete at time of request.
1. Advise County of pending insurance changeover requirements.
 2. Make final changeover of permanent locks and deliver keys to County. Advise County's personnel of changeover in security provisions.
 3. Complete startup and testing of systems and equipment.
 4. Perform preventive maintenance on equipment used prior to Substantial Completion.
 5. Instruct Owner's personnel in operation, adjustment, and maintenance of products, equipment, and systems. Submit demonstration and training video recordings specified in Section 017900 "Demonstration and Training."
 6. Advise Owner of changeover in utility services.
 7. Participate with Owner in conducting inspection and walkthrough with local emergency responders.
 8. Terminate and remove temporary facilities from Project site, along with mockups, construction tools, and similar elements.
 9. Complete final cleaning requirements.
 10. Touch up paint and otherwise repair and restore marred exposed finishes to eliminate visual defects.

- E. Validation: Submit a written request for validation of Substantial Completion. On receipt of request, Arlington County will either proceed with validation or notify Contractor of unfulfilled requirements. A/E will prepare the Certificate of Substantial Completion after substantial completion validation or will notify Contractor of items, either on Contractor's list or additional items identified by A/E, which must be completed or corrected before certificate will be issued.
- F. Upon issuance of a Certificate of Substantial Completion, the seasonal commissioning and warranty period shall begin. As a component of the warranty period, the contractor shall participate in the seasonal commissioning activities as required by Commissioning Specification Section. Seasonal commissioning shall occur regardless of the time of year in which Substantial Completion occurs.
- G. At Substantial Completion of the Contract (this does not include individual phase), the retainage, or escrow, may be reduced at the Project Officers approval (no less than 1% remaining).
- H. Inspection: Submit a written request for inspection to determine Substantial Completion a minimum of 10 days prior to date the Work will be completed and ready for final inspection and tests. On receipt of request, Architect will either proceed with inspection or notify Contractor of unfulfilled requirements. Architect will prepare the Certificate of Substantial Completion after inspection or will notify Contractor of items, either on Contractor's list or additional items identified by Architect, that must be completed or corrected before certificate will be issued.
 - 1. Request reinspection when the Work identified in previous inspections as incomplete is completed or corrected.
 - 2. Results of completed inspection will form the basis of requirements for final completion.

1.7 FINAL COMPLETION PROCEDURES

- A. Submittals Prior to Final Completion: Before requesting final inspection for determining final completion, complete the following:
 - 1. Submit a final Application for Payment according to Section 012900 "Payment Procedures."
 - 2. Certified List of Incomplete Items: Submit certified copy of Architect's Substantial Completion inspection list of items to be completed or corrected (punch list), endorsed and dated by Architect. Certified copy of the list shall state that each item has been completed or otherwise resolved for acceptance.
 - 3. Certificate of Insurance: Submit evidence of final, continuing insurance coverage complying with insurance requirements.
 - 4. Submit pest-control final inspection report.
 - 5. Submit final completion photographic documentation.
- B. Inspection: Submit a written request for final inspection to determine acceptance a minimum of 10 days prior to date the work will be completed and ready for final inspection and tests. On receipt of request, Architect will either proceed with inspection or notify Contractor of unfulfilled requirements. Architect will prepare a final Certificate for Payment after inspection or will notify Contractor of construction that must be completed or corrected before certificate will be issued.

1. Request reinspection when the Work identified in previous inspections as incomplete is completed or corrected.

1.8 LIST OF INCOMPLETE ITEMS (PUNCH LIST)

- A. Organization of List: Include name and identification of each space and area affected by construction operations for incomplete items and items needing correction including, if necessary, areas disturbed by Contractor that are outside the limits of construction.
 1. Organize list of spaces in sequential order, starting with exterior areas first and proceeding from lowest floor to highest floor.
 2. Organize items applying to each space by major element, including categories for ceiling, individual walls, floors, equipment, and building systems.
 3. Include the following information at the top of each page:
 - a. Project name.
 - b. Date.
 - c. Name of Architect.
 - d. Name of Contractor.
 - e. Page number.

1.9 SUBMITTAL OF PROJECT WARRANTIES

- A. Time of Submittal: Submit written warranties on request of Architect for designated portions of the Work where warranties are indicated to commence on dates other than date of Substantial Completion, or when delay in submittal of warranties might limit Owner's rights under warranty.
- B. Partial Occupancy: Submit properly executed warranties within 15 days of completion of designated portions of the Work that are completed and occupied or used by Owner during construction period by separate agreement with Contractor.
- C. Organize warranty documents into an orderly sequence based on the table of contents of Project Manual.
- D. Warranty Electronic File: Provide warranties and bonds in PDF format. Assemble complete warranty and bond submittal package into a single electronic PDF file with bookmarks enabling navigation to each item. Provide bookmarked table of contents at beginning of document.
 1. Submit on digital media acceptable to Architect.
- E. Provide additional copies of each warranty to include in operation and maintenance manuals.

PART 2 - PRODUCTS

2.1 MATERIALS

- A. Cleaning Agents: Use cleaning materials and agents recommended by manufacturer or fabricator of the surface to be cleaned. Do not use cleaning agents that are potentially hazardous to health or property or that might damage finished surfaces.

PART 3 - EXECUTION

3.1 FINAL CLEANING

- A. General: Perform final cleaning. Conduct cleaning and waste-removal operations to comply with local laws and ordinances and Federal and local environmental and antipollution regulations.
- B. Cleaning: Employ experienced workers or professional cleaners for final cleaning. Clean each surface or unit to condition expected in an average commercial building cleaning and maintenance program. Comply with manufacturer's written instructions.
 - 1. Complete the following cleaning operations before requesting inspection for certification of Substantial Completion for entire Project or for a designated portion of Project:
 - a. Clean Project site, yard, and grounds, in areas disturbed by construction activities, including landscape development areas, of rubbish, waste material, litter, and other foreign substances.
 - b. Sweep paved areas broom clean. Remove petrochemical spills, stains, and other foreign deposits.
 - c. Rake grounds that are not planted, mulched, or paved to a smooth, even-textured surface.
 - d. Remove tools, construction equipment, machinery, and surplus material from Project site.
 - e. Remove snow and ice to provide safe access to building.
 - f. Clean exposed exterior and interior hard-surfaced finishes to a dirt-free condition, free of stains, films, and similar foreign substances. Avoid disturbing natural weathering of exterior surfaces. Restore reflective surfaces to their original condition.
 - g. Remove debris and surface dust from limited access spaces, including roofs, plenums, shafts, trenches, equipment vaults, manholes, attics, and similar spaces.
 - h. Sweep concrete floors broom clean in unoccupied spaces.
 - i. Vacuum carpet and similar soft surfaces, removing debris and excess nap; clean according to manufacturer's recommendations if visible soil or stains remain.
 - j. Clean transparent materials, including mirrors and glass in doors and windows. Remove glazing compounds and other noticeable, vision-obscuring materials. Polish mirrors and glass, taking care not to scratch surfaces.
 - k. Remove labels that are not permanent.

- l. Wipe surfaces of mechanical and electrical equipment and similar equipment. Remove excess lubrication, paint and mortar droppings, and other foreign substances.
 - m. Clean plumbing fixtures to a sanitary condition, free of stains, including stains resulting from water exposure.
 - n. Replace disposable air filters and clean permanent air filters. Clean exposed surfaces of diffusers, registers, and grills.
 - o. Clean luminaires, lamps, globes, and reflectors to function with full efficiency.
 - p. Leave Project clean and ready for occupancy.
- C. Pest Control: Comply with pest control requirements in Section 015000 "Temporary Facilities and Controls." Prepare written report.
- D. Construction Waste Disposal: Comply with waste disposal requirements in Section 017419 "Construction Waste Management and Disposal."

3.2 REPAIR OF THE WORK

- A. Complete repair and restoration operations before requesting inspection for determination of Substantial Completion.
- B. Repair, or remove and replace, defective construction. Repairing includes replacing defective parts, refinishing damaged surfaces, touching up with matching materials, and properly adjusting operating equipment. Where damaged or worn items cannot be repaired or restored, provide replacements. Remove and replace operating components that cannot be repaired. Restore damaged construction and permanent facilities used during construction to specified condition.
1. Remove and replace chipped, scratched, and broken glass, reflective surfaces, and other damaged transparent materials.
 2. Touch up and otherwise repair and restore marred or exposed finishes and surfaces. Replace finishes and surfaces that already show evidence of repair or restoration.
 - a. Do not paint over "UL" and other required labels and identification, including mechanical and electrical nameplates. Remove paint applied to required labels and identification.
 3. Replace parts subject to operating conditions during construction that may impede operation or reduce longevity.
 4. Replace burned-out bulbs, bulbs noticeably dimmed by hours of use, and defective and noisy starters in fluorescent and mercury vapor fixtures to comply with requirements for new fixtures.

END OF SECTION 017700

THIS PAGE INTENSIONALLY LEFT BLANK

Copyright 2015 by The American Institute of Architects (AIA)

SECTION 017823 - OPERATION AND MAINTENANCE DATA

PART 1 - GENERAL

1.1 RELATED DOCUMENTS

- A. Drawings and general provisions of the Contract, including General and Supplementary Conditions and other Division 01 Specification Sections, apply to this Section.

1.2 SUMMARY

- A. Section includes administrative and procedural requirements for preparing operation and maintenance manuals, including the following:
 - 1. Operation and maintenance documentation directory manuals.
 - 2. Emergency manuals.
 - 3. Systems and equipment operation manuals.
 - 4. Systems and equipment maintenance manuals.
 - 5. Product maintenance manuals.
- B. Related Requirements:
 - 1. Section 013300 "Submittal Procedures" for submitting copies of submittals for operation and maintenance manuals.
 - 2. Section 019113 "General Commissioning Requirements" for verification and compilation of data into operation and maintenance manuals.
 - 3. Comply with Section 017700 "Closeout Procedures" for schedule for submitting operation and maintenance documentation.

1.3 DEFINITIONS

- A. System: An organized collection of parts, equipment, or subsystems united by regular interaction.
- B. Subsystem: A portion of a system with characteristics similar to a system.

1.4 CLOSEOUT SUBMITTALS

- A. Submit operation and maintenance manuals indicated. Provide content for each manual as specified in individual Specification Sections, and as reviewed and approved at the time of Section submittals. Submit reviewed manual content formatted and organized as required by this Section.

1. Architect and Commissioning Authority will comment on whether content of operation and maintenance submittals is acceptable.
 2. Where applicable, clarify and update reviewed manual content to correspond to revisions and field conditions.
- B. Format: Submit operation and maintenance manuals in the following format:
1. Submit on digital media acceptable to Architect by uploading to web-based project software site or by email to Architect. Enable reviewer comments on draft submittals.
- C. Initial Manual Submittal: Submit draft copy of each manual at least 30 days before commencing demonstration and training. Architect and Commissioning Authority will comment on whether general scope and content of manual are acceptable.
- D. Final Manual Submittal: Submit each manual in final form prior to requesting inspection for Substantial Completion and at least 15 days before commencing demonstration and training. Architect and Commissioning Authority will return copy with comments.
1. Correct or revise each manual to comply with Architect's and Commissioning Authority's comments. Submit copies of each corrected manual within 15 days of receipt of Architect's and Commissioning Authority's comments and prior to commencing demonstration and training.
- E. Comply with Section 017700 "Closeout Procedures" for schedule for submitting operation and maintenance documentation.
- 1.5 FORMAT OF OPERATION AND MAINTENANCE MANUALS
- A. Manuals, Electronic Files: Submit manuals in the form of a multiple file composite electronic PDF file for each manual type required.
1. Electronic Files: Use electronic files prepared by manufacturer where available. Where scanning of paper documents is required, configure scanned file for minimum readable file size.
 2. File Names and Bookmarks: Bookmark individual documents based on file names. Name document files to correspond to system, subsystem, and equipment names used in manual directory and table of contents. Group documents for each system and subsystem into individual composite bookmarked files, then create composite manual, so that resulting bookmarks reflect the system, subsystem, and equipment names in a readily navigated file tree. Configure electronic manual to display bookmark panel on opening file.
- 1.6 REQUIREMENTS FOR EMERGENCY, OPERATION, AND MAINTENANCE MANUALS
- A. Directory: Prepare a single, comprehensive directory of emergency, operation, and maintenance data and materials, listing items and their location to facilitate ready access to desired information.

-
- B. Organization of Manuals: Unless otherwise indicated, organize each manual into a separate section for each system and subsystem, and a separate section for each piece of equipment not part of a system. Each manual shall contain the following materials, in the order listed:
1. Title page.
 2. Table of contents.
 3. Manual contents.
- C. Title Page: Include the following information:
1. Subject matter included in manual.
 2. Name and address of Project.
 3. Name and address of Owner.
 4. Date of submittal.
 5. Name and contact information for Contractor.
 6. Name and contact information for Construction Manager.
 7. Name and contact information for Architect.
 8. Name and contact information for Commissioning Authority.
 9. Names and contact information for major consultants to the Architect that designed the systems contained in the manuals.
 10. Cross-reference to related systems in other operation and maintenance manuals.
- D. Table of Contents: List each product included in manual, identified by product name, indexed to the content of the volume, and cross-referenced to Specification Section number in Project Manual.
1. If operation or maintenance documentation requires more than one volume to accommodate data, include comprehensive table of contents for all volumes in each volume of the set.
- E. Manual Contents: Organize into sets of manageable size. Arrange contents alphabetically by system, subsystem, and equipment. If possible, assemble instructions for subsystems, equipment, and components of one system into a single binder.
- F. Identification: In the documentation directory and in each operation and maintenance manual, identify each system, subsystem, and piece of equipment with same designation used in the Contract Documents. If no designation exists, assign a designation according to ASHRAE Guideline 4, "Preparation of Operating and Maintenance Documentation for Building Systems."
- 1.7 OPERATION AND MAINTENANCE DOCUMENTATION DIRECTORY MANUAL
- A. Operation and Maintenance Documentation Directory: Prepare a separate manual that provides an organized reference to emergency, operation, and maintenance manuals. List items and their location to facilitate ready access to desired information. Include the following:
1. List of Systems and Subsystems: List systems alphabetically. Include references to operation and maintenance manuals that contain information about each system.
 2. List of Equipment: List equipment for each system, organized alphabetically by system. For pieces of equipment not part of system, list alphabetically in separate list.

3. Tables of Contents: Include a table of contents for each emergency, operation, and maintenance manual.

1.8 EMERGENCY MANUALS

- A. Emergency Manual: Assemble a complete set of emergency information indicating procedures for use by emergency personnel and by County's operating personnel for types of emergencies indicated.
- B. Content: Organize manual into a separate section for each of the following:
 1. Type of emergency.
 2. Emergency instructions.
 3. Emergency procedures.
- C. Type of Emergency: Where applicable for each type of emergency indicated below, include instructions and procedures for each system, subsystem, piece of equipment, and component:
 1. Fire.
 2. Flood.
 3. Gas leak.
 4. Water leak.
 5. Power failure.
 6. Water outage.
 7. System, subsystem, or equipment failure.
 8. Chemical release or spill.
- D. Emergency Instructions: Describe and explain warnings, trouble indications, error messages, and similar codes and signals. Include responsibilities of County's operating personnel for notification of Installer, supplier, and manufacturer to maintain warranties.
- E. Emergency Procedures: Include the following, as applicable:
 1. Instructions on stopping.
 2. Shutdown instructions for each type of emergency.
 3. Operating instructions for conditions outside normal operating limits.
 4. Required sequences for electric or electronic systems.
 5. Special operating instructions and procedures.

1.9 SYSTEMS AND EQUIPMENT OPERATION MANUALS

- A. Systems and Equipment Operation Manual: Assemble a complete set of data indicating operation of each system, subsystem, and piece of equipment not part of a system. Include information required for daily operation and management, operating standards, and routine and special operating procedures.
 1. Engage a factory-authorized service representative to assemble and prepare information for each system, subsystem, and piece of equipment not part of a system.

2. Prepare a separate manual for each system and subsystem, in the form of an instructional manual for use by County's operating personnel.
- B. Content: In addition to requirements in this Section, include operation data required in individual Specification Sections and the following information:
1. System, subsystem, and equipment descriptions. Use designations for systems and equipment indicated on Contract Documents.
 2. Performance and design criteria if Contractor has delegated design responsibility.
 3. Operating standards.
 4. Operating procedures.
 5. Operating logs.
 6. Wiring diagrams.
 7. Control diagrams.
 8. Piped system diagrams.
 9. Precautions against improper use.
 10. License requirements including inspection and renewal dates.
- C. Descriptions: Include the following:
1. Product name and model number. Use designations for products indicated on Contract Documents.
 2. Manufacturer's name.
 3. Equipment identification with serial number of each component.
 4. Equipment function.
 5. Operating characteristics.
 6. Limiting conditions.
 7. Performance curves.
 8. Engineering data and tests.
 9. Complete nomenclature and number of replacement parts.
- D. Operating Procedures: Include the following, as applicable:
1. Startup procedures.
 2. Equipment or system break-in procedures.
 3. Routine and normal operating instructions.
 4. Regulation and control procedures.
 5. Instructions on stopping.
 6. Normal shutdown instructions.
 7. Seasonal and weekend operating instructions.
 8. Required sequences for electric or electronic systems.
 9. Special operating instructions and procedures.
- E. Systems and Equipment Controls: Describe the sequence of operation, and diagram controls as installed.
- F. Piped Systems: Diagram piping as installed and identify color coding where required for identification.

1.10 SYSTEMS AND EQUIPMENT MAINTENANCE MANUALS

- A. Systems and Equipment Maintenance Manuals: Assemble a complete set of data indicating maintenance of each system, subsystem, and piece of equipment not part of a system. Include manufacturers' maintenance documentation, preventive maintenance procedures and frequency, repair procedures, wiring and systems diagrams, lists of spare parts, and warranty information.
1. Engage a factory-authorized service representative to assemble and prepare information for each system, subsystem, and piece of equipment not part of a system.
 2. Prepare a separate manual for each system and subsystem, in the form of an instructional manual for use by County's operating personnel.
- B. Content: For each system, subsystem, and piece of equipment not part of a system, include source information, manufacturers' maintenance documentation, maintenance procedures, maintenance and service schedules, spare parts list and source information, maintenance service contracts, and warranties and bonds as described below.
- C. Source Information: List each system, subsystem, and piece of equipment included in manual, identified by product name and arranged to match manual's table of contents. For each product, list name, address, and telephone number of Installer or supplier and maintenance service agent, and cross-reference Specification Section number and title in Project Manual and drawing or schedule designation or identifier where applicable.
- D. Manufacturers' Maintenance Documentation: Include the following information for each component part or piece of equipment:
1. Standard maintenance instructions and bulletins; include only sheets pertinent to product or component installed. Mark each sheet to identify each product or component incorporated into the Work. If data include more than one item in a tabular format, identify each item using appropriate references from the Contract Documents. Identify data applicable to the Work and delete references to information not applicable.
 - a. Prepare supplementary text if manufacturers' standard printed data are not available and where the information is necessary for proper operation and maintenance of equipment or systems.
 2. Drawings, diagrams, and instructions required for maintenance, including disassembly and component removal, replacement, and assembly.
 3. Identification and nomenclature of parts and components.
 4. List of items recommended to be stocked as spare parts.
- E. Maintenance Procedures: Include the following information and items that detail essential maintenance procedures:
1. Test and inspection instructions.
 2. Troubleshooting guide.
 3. Precautions against improper maintenance.
 4. Disassembly; component removal, repair, and replacement; and reassembly instructions.
 5. Aligning, adjusting, and checking instructions.
 6. Demonstration and training video recording, if available.

-
- F. Maintenance and Service Schedules: Include service and lubrication requirements, list of required lubricants for equipment, and separate schedules for preventive and routine maintenance and service with standard time allotment.
1. Scheduled Maintenance and Service: Tabulate actions for daily, weekly, monthly, quarterly, semiannual, and annual frequencies.
 2. Maintenance and Service Record: Include manufacturers' forms for recording maintenance.
- G. Spare Parts List and Source Information: Include lists of replacement and repair parts, with parts identified and cross-referenced to manufacturers' maintenance documentation and local sources of maintenance materials and related services.
- H. Maintenance Service Contracts: Include copies of maintenance agreements with name and telephone number of service agent.
- I. Warranties and Bonds: Include copies of warranties and bonds and lists of circumstances and conditions that would affect validity of warranties or bonds.
1. Include procedures to follow and required notifications for warranty claims.
- J. Drawings: Prepare drawings supplementing manufacturers' printed data to illustrate the relationship of component parts of equipment and systems and to illustrate control sequence and flow diagrams. Coordinate these drawings with information contained in record Drawings to ensure correct illustration of completed installation.
1. Do not use original project record documents as part of maintenance manuals.
- 1.11 PRODUCT MAINTENANCE MANUALS
- A. Product Maintenance Manual: Assemble a complete set of maintenance data indicating care and maintenance of each product, material, and finish incorporated into the Work.
- B. Content: Organize manual into a separate section for each product, material, and finish. Include source information, product information, maintenance procedures, repair materials and sources, and warranties and bonds, as described below.
- C. Source Information: List each product included in manual, identified by product name and arranged to match manual's table of contents. For each product, list name, address, and telephone number of Installer or supplier and maintenance service agent, and cross-reference Specification Section number and title in Project Manual and drawing or schedule designation or identifier where applicable.
- D. Product Information: Include the following, as applicable:
1. Product name and model number.
 2. Manufacturer's name.
 3. Color, pattern, and texture.
 4. Material and chemical composition.
 5. Reordering information for specially manufactured products.

- E. Maintenance Procedures: Include manufacturer's written recommendations and the following:
 - 1. Inspection procedures.
 - 2. Types of cleaning agents to be used and methods of cleaning.
 - 3. List of cleaning agents and methods of cleaning detrimental to product.
 - 4. Schedule for routine cleaning and maintenance.
 - 5. Repair instructions.

- F. Repair Materials and Sources: Include lists of materials and local sources of materials and related services.

- G. Warranties and Bonds: Include copies of warranties and bonds and lists of circumstances and conditions that would affect validity of warranties or bonds.
 - 1. Include procedures to follow and required notifications for warranty claims.

PART 2 - PRODUCTS (Not Used)

PART 3 - EXECUTION (Not Used)

END OF SECTION 017823

Copyright 2015 by The American Institute of Architects (AIA)

SECTION 017839 - PROJECT RECORD DOCUMENTS

PART 1 - GENERAL

1.1 RELATED DOCUMENTS

- A. Drawings and general provisions of the Contract, including General and Supplementary Conditions and other Division 01 Specification Sections, apply to this Section.

1.2 SUMMARY

- A. Section includes administrative and procedural requirements for project record documents, including the following:
 - 1. Record Drawings.
 - 2. Record Specifications.
 - 3. Record Product Data.
 - 4. Miscellaneous record submittals.
- B. Related Requirements:
 - 1. Section 017300 "Execution" for final property survey.
 - 2. Section 017700 "Closeout Procedures" for general closeout procedures.
 - 3. Section 017823 "Operation and Maintenance Data" for operation and maintenance manual requirements.

1.3 CLOSEOUT SUBMITTALS

- A. Record Drawings: Comply with the following:
 - 1. Number of Copies: Submit copies of record Drawings as follows:
 - a. Initial Submittal:
 - 1) Submit record digital data files and one set(s) of plots.
 - 2) Architect will indicate whether general scope of changes, additional information recorded, and quality of drafting are acceptable.
 - b. Final Submittal:
 - 1) Submit one paper-copy set(s) of marked-up record prints.
 - 2) Submit record digital data files and three set(s) of record digital data file plots.
 - 3) Plot each drawing file, whether or not changes and additional information were recorded.

- B. Record Specifications: Submit one paper copy and one annotated PDF electronic files of Project's Specifications, including addenda and contract modifications.
- C. Record Product Data: Submit one paper copy and one annotated PDF electronic files and directories of each submittal.
 - 1. Where record Product Data are required as part of operation and maintenance manuals, submit duplicate marked-up Product Data as a component of manual.
- D. Miscellaneous Record Submittals: See other Specification Sections for miscellaneous record-keeping requirements and submittals in connection with various construction activities. Submit one paper copy and one annotated PDF electronic files and directories of each submittal.
- E. Reports: Submit written report weekly indicating items incorporated into project record documents concurrent with progress of the Work, including revisions, concealed conditions, field changes, product selections, and other notations incorporated.

1.4 RECORD DRAWINGS

- A. Record Prints: Maintain one set of marked-up paper copies of the Contract Drawings and Shop Drawings, incorporating new and revised drawings as modifications are issued.
 - 1. Preparation: Mark record prints to show the actual installation where installation varies from that shown originally. Require individual or entity who obtained record data, whether individual or entity is Installer, subcontractor, or similar entity, to provide information for preparation of corresponding marked-up record prints.
 - a. Give particular attention to information on concealed elements that would be difficult to identify or measure and record later.
 - b. Accurately record information in an acceptable drawing technique.
 - c. Record data as soon as possible after obtaining it.
 - d. Record and check the markup before enclosing concealed installations.
 - e. Cross-reference record prints to corresponding photographic documentation.
 - 2. Content: Types of items requiring marking include, but are not limited to, the following:
 - a. RFI's
 - b. Clarifications made in approved submittals
 - c. Dimensional changes to Drawings.
 - d. Revisions to details shown on Drawings.
 - e. Depths of foundations.
 - f. Locations and depths of underground utilities.
 - g. Revisions to routing of piping and conduits.
 - h. Revisions to electrical circuitry.
 - i. Actual equipment locations.
 - j. Duct size and routing.
 - k. Locations of concealed internal and underground utilities.
 - l. Changes made following Architect's written orders.
 - m. Details not on the original Contract Drawings.
 - n. Field records for variable and concealed conditions.

- o. Record information on the Work that is shown only schematically.
 - p. Modifications to equipment schedules, with specific attention to deviations from named "Basis of Design" vendors and equipment capacities.
 - q. Modifications to Building Automation Controls systems operating logic.
 - r. Any changes in grade and location of duct banks and appurtenances.
 3. Mark the Contract Drawings and Shop Drawings completely and accurately. Use personnel proficient at recording graphic information in production of marked-up record prints.
 4. Mark record sets with erasable, red-colored pencil. Use other colors to distinguish between changes for different categories of the Work at same location.
 5. Mark important additional information that was either shown schematically or omitted from original Drawings.
 6. Note Construction Change Directive numbers, alternate numbers, Change Order numbers, and similar identification, where applicable.
- B. Record Digital Data Files: Immediately before inspection for Certificate of Substantial Completion, review marked-up record prints with Architect. When authorized, prepare a full set of corrected digital data files of the Contract Drawings, as follows:
 1. Format: Annotated PDF electronic file.
 2. Incorporate changes and additional information previously marked on record prints. Delete, redraw, and add details and notations where applicable.
 3. Refer instances of uncertainty to Architect for resolution.
 4. Architect will furnish Contractor with one set of digital data files of the Contract Drawings for use in recording information.
 - a. See Section 013100 "Project Management and Coordination" for requirements related to use of Architect's digital data files.
 - b. Architect will provide data file layer information. Record markups in separate layers.
- C. Format: Identify and date each record Drawing; include the designation "PROJECT RECORD DRAWING" in a prominent location.
 1. Record Prints: Organize record prints into manageable sets. Bind each set with durable paper cover sheets. Include identification on cover sheets.
 2. Format: Annotated PDF electronic file with comment function enabled.
 3. Record Digital Data Files: Organize digital data information into separate electronic files that correspond to each sheet of the Contract Drawings. Name each file with the sheet identification. Include identification in each digital data file.
 4. Identification: As follows:
 - a. Project name.
 - b. Date.
 - c. Designation "PROJECT RECORD DRAWINGS."
 - d. Name of Architect.
 - e. Name of Contractor.

1.5 RECORD SPECIFICATIONS

- A. Preparation: Mark Specifications to indicate the actual product installation where installation varies from that indicated in Specifications, addenda, and contract modifications.
 - 1. Give particular attention to information on concealed products and installations that cannot be readily identified and recorded later.
 - 2. Mark copy with the proprietary name and model number of products, materials, and equipment furnished, including substitutions and product options selected.
 - 3. Record the name of manufacturer, supplier, Installer, and other information necessary to provide a record of selections made.
 - 4. Note related Change Orders, record Product Data, and record Drawings where applicable.
- B. Format: Submit record Specifications as annotated PDF electronic file and one paper copy.

1.6 RECORD PRODUCT DATA

- A. Recording: Maintain one copy of each submittal during the construction period for project record document purposes. Post changes and revisions to project record documents as they occur; do not wait until end of Project.
- B. Preparation: Mark Product Data to indicate the actual product installation where installation varies substantially from that indicated in Product Data submittal.
 - 1. Give particular attention to information on concealed products and installations that cannot be readily identified and recorded later.
 - 2. Include significant changes in the product delivered to Project site and changes in manufacturer's written instructions for installation.
 - 3. Note related Change Orders, record Specifications, and record Drawings where applicable.
- C. Format: Submit record Product Data as annotated PDF electronic file.
 - 1. Include record Product Data directory organized by Specification Section number and title, electronically linked to each item of record Product Data.

1.7 MISCELLANEOUS RECORD SUBMITTALS

- A. Assemble miscellaneous records required by other Specification Sections for miscellaneous record keeping and submittal in connection with actual performance of the Work. Bind or file miscellaneous records and identify each, ready for continued use and reference.
- B. Format: Submit miscellaneous record submittals as PDF electronic file.
 - 1. Include miscellaneous record submittals directory organized by Specification Section number and title, electronically linked to each item of miscellaneous record submittals.

1.8 MAINTENANCE OF RECORD DOCUMENTS

- A. Maintenance of Record Documents: Store record documents in the field office apart from the Contract Documents used for construction. Do not use project record documents for construction purposes. Maintain record documents in good order and in a clean, dry, legible condition, protected from deterioration and loss. Provide access to project record documents for Architect's reference during normal working hours.

PART 2 - PRODUCTS (Not Used)

PART 3 - EXECUTION (Not Used)

END OF SECTION 017839

THIS PAGE INTENSIONALLY LEFT BLANK

Copyright 2015 by The American Institute of Architects (AIA)

SECTION 017900 - DEMONSTRATION AND TRAINING

PART 1 - GENERAL

1.1 RELATED DOCUMENTS

- A. Drawings and general provisions of the Contract, including General and Supplementary Conditions and other Division 01 Specification Sections, apply to this Section.

1.2 SUMMARY

- A. Section includes administrative and procedural requirements for instructing County's personnel, including the following:
 - 1. Instruction in operation and maintenance of systems, subsystems, and equipment.
 - 2. Demonstration and training video recordings.

1.3 INFORMATIONAL SUBMITTALS

- A. Instruction Program: Submit outline of instructional program for demonstration and training, including a list of training modules and a schedule of proposed dates, times, length of instruction time, and instructors' names for each training module. Include learning objective and outline for each training module.
 - 1. Indicate proposed training modules using manufacturer-produced demonstration and training video recordings for systems, equipment, and products in lieu of video recording of live instructional module.
- B. Qualification Data: For firms and persons specified in "Quality Assurance" Article to demonstrate their capabilities and experience. Include lists of completed projects with project names and addresses, names and addresses of architects and Countys, and other information specified. And for instructor.
- C. Attendance Record: For each training module, submit list of participants and length of instruction time.
- D. Evaluations: For each participant and for each training module, submit results and documentation of performance-based test.

1.4 CLOSEOUT SUBMITTALS

- A. Demonstration and Training Video Recordings: Submit two copies within seven days of end of each training module.

1. Identification: On each copy, provide an applied label with the following information:
 - a. Name of Project.
 - b. Name and address of videographer.
 - c. Name of Architect.
 - d. Name of Construction Manager.
 - e. Name of Contractor.
 - f. Date of video recording.
2. Transcript: Prepared in PDF electronic format. Include a cover sheet with same label information as the corresponding video recording and a table of contents with links to corresponding training components. Include name of Project and date of video recording on each page.
3. At completion of training, submit complete training manual(s) for County's use prepared in same PDF file format required for operation and maintenance manuals specified in Section 017823 "Operation and Maintenance Data."

1.5 QUALITY ASSURANCE

- A. Facilitator Qualifications: A firm or individual experienced in training or educating maintenance personnel in a training program similar in content and extent to that indicated for this Project, and whose work has resulted in training or education with a record of successful learning performance.
- B. Instructor Qualifications: A factory-authorized service representative, complying with requirements in Section 014000 "Quality Requirements," experienced in operation and maintenance procedures and training.
- C. Videographer Qualifications: A professional videographer who is experienced photographing demonstration and training events similar to those required.
- D. Pre-instruction Conference: Conduct conference at Project site to comply with requirements in Section 013100 "Project Management and Coordination." Review methods and procedures related to demonstration and training including, but not limited to, the following:
 1. Inspect and discuss locations and other facilities required for instruction.
 2. Review and finalize instruction schedule and verify availability of educational materials, instructors' personnel, audiovisual equipment, and facilities needed to avoid delays.
 3. Review required content of instruction.
 4. For instruction that must occur outside, review weather and forecasted weather conditions and procedures to follow if conditions are unfavorable.

1.6 COORDINATION

- A. Coordinate instruction schedule with County's operations. Adjust schedule as required to minimize disrupting County's operations and to ensure availability of County's personnel.
- B. Coordinate instructors, including providing notification of dates, times, length of instruction time, and course content.

- C. Coordinate content of training modules with content of approved emergency, operation, and maintenance manuals. Do not submit instruction program until operation and maintenance data have been reviewed and approved by Architect.

1.7 INSTRUCTION PROGRAM

- A. Program Structure: Develop an instruction program that includes individual training modules for each system and for equipment not part of a system, as required by individual Specification Sections.
- B. Training Modules: Develop a learning objective and teaching outline for each module. Include a description of specific skills and knowledge that participant is expected to master. For each module, include instruction for the following as applicable to the system, equipment, or component:
 - 1. Basis of System Design, Operational Requirements, and Criteria: Include the following:
 - a. System, subsystem, and equipment descriptions.
 - b. Performance and design criteria if Contractor is delegated design responsibility.
 - c. Operating standards.
 - d. Regulatory requirements.
 - e. Equipment function.
 - f. Operating characteristics.
 - g. Limiting conditions.
 - h. Performance curves.
 - 2. Documentation: Review the following items in detail:
 - a. Emergency manuals.
 - b. Systems and equipment operation manuals.
 - c. Systems and equipment maintenance manuals.
 - d. Product maintenance manuals.
 - e. Project Record Documents.
 - f. Identification systems.
 - g. Warranties and bonds.
 - h. Maintenance service agreements and similar continuing commitments.
 - 3. Emergencies: Include the following, as applicable:
 - a. Instructions on meaning of warnings, trouble indications, and error messages.
 - b. Instructions on stopping.
 - c. Shutdown instructions for each type of emergency.
 - d. Operating instructions for conditions outside of normal operating limits.
 - e. Sequences for electric or electronic systems.
 - f. Special operating instructions and procedures.
 - 4. Operations: Include the following, as applicable:
 - a. Startup procedures.
 - b. Equipment or system break-in procedures.

- c. Routine and normal operating instructions.
 - d. Regulation and control procedures.
 - e. Control sequences.
 - f. Safety procedures.
 - g. Instructions on stopping.
 - h. Normal shutdown instructions.
 - i. Operating procedures for emergencies.
 - j. Operating procedures for system, subsystem, or equipment failure.
 - k. Seasonal and weekend operating instructions.
 - l. Required sequences for electric or electronic systems.
 - m. Special operating instructions and procedures.
5. Adjustments: Include the following:
- a. Alignments.
 - b. Checking adjustments.
 - c. Noise and vibration adjustments.
 - d. Economy and efficiency adjustments.
6. Troubleshooting: Include the following:
- a. Diagnostic instructions.
 - b. Test and inspection procedures.
7. Maintenance: Include the following:
- a. Inspection procedures.
 - b. Types of cleaning agents to be used and methods of cleaning.
 - c. List of cleaning agents and methods of cleaning detrimental to product.
 - d. Procedures for routine cleaning.
 - e. Procedures for preventive maintenance.
 - f. Procedures for routine maintenance.
 - g. Instruction on use of special tools.
8. Repairs: Include the following:
- a. Diagnosis instructions.
 - b. Repair instructions.
 - c. Disassembly; component removal, repair, and replacement; and reassembly instructions.
 - d. Instructions for identifying parts and components.
 - e. Review of spare parts needed for operation and maintenance.

1.8 PREPARATION

- A. Assemble educational materials necessary for instruction, including documentation and training module. Assemble training modules into a training manual organized in coordination with requirements in Section 017823 "Operation and Maintenance Data."
- B. Set up instructional equipment at instruction location.

1.9 INSTRUCTION

- A. Facilitator: Engage a qualified facilitator to prepare instruction program and training modules, to coordinate instructors, and to coordinate between Contractor and County for number of participants, instruction times, and location.
- B. Engage qualified instructors to instruct County's personnel to adjust, operate, and maintain systems, subsystems, and equipment not part of a system.
 - 1. County will furnish Contractor with names and positions of participants.
- C. Scheduling: Provide instruction at mutually agreed-on times. For equipment that requires seasonal operation, provide similar instruction at start of each season.
 - 1. Schedule training with County with at least seven days' advance notice.
- D. Training Location and Reference Material: Conduct training on-site in the completed and fully operational facility using the actual equipment in-place. Conduct training using final operation and maintenance data submittals.
- E. Evaluation: At conclusion of each training module, assess and document each participant's mastery of module by use of a written performance-based test.
- F. Cleanup: Collect used and leftover educational materials and give to County. Remove instructional equipment. Restore systems and equipment to condition existing before initial training use.

1.10 DEMONSTRATION AND TRAINING VIDEO RECORDINGS

- A. General: Engage a qualified commercial videographer to record demonstration and training video recordings. Record each training module separately. Include classroom instructions and demonstrations, board diagrams, and other visual aids, but not student practice.
 - 1. At beginning of each training module, record each chart containing learning objective and lesson outline.
- B. Digital Video Recordings: Provide high-resolution, digital video in MPEG format, produced by a digital camera with minimum sensor resolution of 12 megapixels and capable of recording in full HD mode with vibration reduction technology.
 - 1. Submit video recordings by uploading to web-based Project software site.
 - 2. File Hierarchy: Organize folder structure and file locations according to Project Manual table of contents. Provide complete screen-based menu.
 - 3. File Names: Utilize file names based on name of equipment generally described in video segment, as identified in Project specifications.
 - 4. Contractor and Installer Contact File: Using appropriate software, create a file for inclusion on the equipment demonstration and training recording that describes the following for each Contractor involved on the Project, arranged according to Project Manual table of contents:
 - a. Name of Contractor/Installer.

- b. Business address.
 - c. Business phone number.
 - d. Point of contact.
 - e. Email address.
- C. Recording: Mount camera on tripod before starting recording, unless otherwise necessary to adequately cover area of demonstration and training. Display continuous running time.
- 1. Film training session(s) in segments not to exceed 15 minutes.
 - a. Produce segments to present a single significant piece of equipment per segment.
 - b. Organize segments with multiple pieces of equipment to follow order of Project Manual table of contents.
 - c. Where a training session on a particular piece of equipment exceeds 15 minutes, stop filming and pause training session. Begin training session again upon commencement of new filming segment.
- D. Light Levels: Verify light levels are adequate to properly light equipment. Verify equipment markings are clearly visible prior to recording.
- 1. Furnish additional portable lighting as required.
- E. Narration: Describe scenes on video recording by audio narration by microphone while video recording is recorded. Include description of items being viewed.
- F. Transcript: Provide a transcript of the narration. Display images and running time captured from videotape opposite the corresponding narration segment.
- G. Preproduced Video Recordings: Provide video recordings used as a component of training modules in same format as recordings of live training.

PART 2 - PRODUCTS

PART 3 - EXECUTION

END OF SECTION 017900

SECTION 018113.63 - SUSTAINABLE DESIGN REQUIREMENTS – VIRIDIANT NET-ZERO

PART 1 - GENERAL

1.1 SUMMARY

- A. Section includes general requirements and procedures for compliance with Arlington County’s “Facility Sustainability Policy” for New Construction and Major Renovations (Green Building Policy) – The above mentioned policy is attached following Section 018113.63 for reference.
- B. Per Arlington County’s Green Building Policy, this project is required to:
 - 1) Be certified by Viridiant’s Earthcraft Program for Single Family Homes
 - a. As background, Viridiant’s Net-Zero Certification program offers support to project teams during the design and construction process. The program is targeted to builders, designers, and homeowners throughout the Southeast who believe in superior building and the next generation of housing. The program consists of a two-part certification; “Net-Zero Ready” once the project has successfully met the program design criteria, construction, and diagnostic testing goals, and “Net-Zero Certified” once the occupants have demonstrated (documented in real time utility tracking) that they have lived an energy neutral or positive lifestyle for one year. The Net-Zero program is intended for new construction or major renovation projects located in the United States in Climate Zones 2a, 3a, and 4a.
 - b. Specific program information about Earthcraft Technical Guidelines and Program requirements are attached following Section 018113.63
 - 2) Achieve Net Zero certification under Viridiant’s Net Zero Program
 - a. Specific program information about Viridiant’s Net Zero Program and its requirements are attached following Section 018113.63
 - b. During the design phase, the Design Team has worked to ensure that the design will meet both Arlington County’s Green Building Policy, as well as Viridiant’s Net Zero Program requirements; a Whole Building Energy Model Simulation has been provided by the Engineering Team to demonstrate this compliance. The Whole Building Energy Model Simulation report is attached following Section 018113.63.

1.2 SCOPE AND RESPONSIBILITIES DURING CONSTRUCTION

A. Pre-Drywall

1) Construction Kick-Off Meeting

a. A Viridiant Technical Adviser (TA) will:

- 1. Review the program requirements and project goals on-site with the general contractor’s project manager and site supervisor, and any subcontractors identified by the General Contractor’s Project Team whose work will be impacted by program standards. Meet with all appropriate contractors invited to the meeting to outline expectations and answer questions.

2. Identify possible building envelope issues (including both air sealing and insulation) not noted at the plan review stage and work with the general contractor and appropriate subcontractors to suggest appropriate modifications or corrections.

b. General Contractor's Project Team Responsibilities:

1. It is the General Contractor's responsibility to schedule the Construction Kick-Off meeting. This meeting should be held prior to foundations being poured but cannot be held until Design Review has been completed.

2) Inspections

a. Viridiant TA will:

1. Conduct visual pre-drywall inspection to evaluate mechanical equipment and duct systems at rough-in for Manual J load calculation sizing and Manual D duct design; duct sealing measures: insulation application to identify possible insulation coverage and envelope issues, and to assess an insulation installation grading. Any re-inspections that may arise as a result of failed inspections are to be paid for by the Contractor, refer to section 018113.63, C.
2. Perform total leakage duct pressure tests on up to three duct systems for informational purposes and contractor education prior to the final installation of drywall. Quantify total duct loss and identify leaks and possible "weak points" in the sampled systems. Review the identified issues with the HVAC subcontractor on site or through written reporting.
3. Produce an inspection report noting any specific deficiencies, identifying problem areas and suggesting corrective measures. Review this report with established Contractor Project Manager contact.

b. General Contractor's Project Team Responsibilities

1. The general contractor is responsible for scheduling pre-drywall inspection at the appropriate time. Details of required inspections will be provided at the Construction Kick-off meeting. Viridiant is not responsible for certification failure due to late scheduling or failure to schedule by the General Contractor's Project Team.
2. Viridiant may require the builder to submit photo documentation to further verify the above measures.

B. Project Closeout

1) Final Diagnostic Assessment and Visual Verification Visits

a. Viridiant TA will:

1. Conduct blower door, duct blaster, whole-house mechanical ventilation, local mechanical exhaust (including bath and kitchen), and bedroom pressure testing to verify

the project meets established envelope infiltration, duct leakage, and bedroom pressure goals. Additional fees for testing outside of the project scope or any re-inspections that may arise as a result of failed inspections are to be paid for by the Contractor, refer to section 018113.63, C.

2. Visually verify installed fixtures and appliances consistent with efficiencies specified for the project.
3. Produce inspection report noting any specific deficiencies, identifying problem areas and suggesting corrective measures. TA is to review this report with the General Contractor, Owner, Architect, and the appropriate subcontractors.
4. Verify energy model at project completion to ensure it reflects as-built building conditions.

b. General Contractor's Project Team Responsibilities

1. The general contractor is responsible for scheduling the final diagnostic inspection and visual verification visit when appropriate. Details of required inspections will be provided at the Construction Kick-off meeting. Viridiant is not responsible for certification failure due to late scheduling or failure to schedule by the General Contractor's Project Team.
2. If the project is occupied before Viridiant performs final testing, the General Contractor's Project Team must prepare the building prior to final tests. This means alerting the residents before the Viridiant TA arrives and ensuring the unit is ready for the inspection. This also includes moving all furniture blocking wall registers or directly underneath ceiling registers, ensuring the mechanical closet is accessible and unlocked, ensuring the water heater is accessible and unlocked, and ensuring there are no additional impediments that would limit the ability to perform the final test. Viridiant will not be able to move any items in order to complete the inspection. A representative of the Owner and a member of General Contractor's Project Team must remain on site during the entirety of the final inspections.

2) Final Review and Certification

a. Viridiant TA will:

1. Review the status of program requirements and completed final inspections.
2. Review all project documentation submissions to date submitted by the General Contractor's Project Team.
 - i. All specific requirements for documentation which are to be provided by the General Contractor's Project Team are outlined in the Earthcraft Program, attached following Section 018113.63
3. Update the energy models.

4. Provide additional written feedback on project verification documentation, if needed. To achieve certification, the project must successfully pass all program requirements and required performance testing.
5. Once outstanding requirements have been reviewed and marked complete, the certification will be awarded.

b. General Contractor's Project Team Responsibilities

1. For specific items (outlined in the Earthcraft Program) it is necessary for the General Contractor's Project Team to supply further documentation to Viridiant including but not limited to official project name (for certification documents), product literature, photographs, order forms, plan details, etc. It is the General Contractor's Project Team's responsibility to provide such items to ensure the project receives final certification.

C. Additional Fees

- 1) Any additional fees which may arise (outside of the original design phase scope) as outlined below are to be paid for by the General Contractor
 - i. Additional Meetings:
 - a) Meetings beyond the Pre-construction kick-off meeting provided in the scope of work established with the Architect will be billed at \$125/hour plus travel beyond 60 miles of the Viridiant office.
 - ii. Re-inspections and/or Additional Diagnostic Testing:
 - a) If re-inspections and/or retesting are required due to failures or the project not being ready for inspection without communication from the contractor, an additional \$100 fee may apply for each reinspection or additional test. General Contractor's Project Teams will be notified in writing with supporting site visit report(s) highlighting delinquent issues prior to fees being assessed.

END OF SECTION 018113.63

APPLICABLE ATTACHMENTS TO FOLLOW THIS SECTION

(PROVIDED FOR REFERENCE AS OUTLINED ABOVE):

1. ARLINGTON COUNTY ADMINISTRATIVE REGULATIONS – GREEN BUILDING POLICY
2. VIRIDIANT EARTHCRAFT HOUSE TECHNICAL GUIDELINES
3. VIRIDIANT NET-ZERO PROGRAM™
4. ARLINGTON GROUP HOUSE - WHOLE BUILDING ENERGY SIMULATION

Subject/Topic: Facility Sustainability Policy – for New Construction and Major Renovation (Green Building Policy)

Topic Category: Green Buildings/Environmental Management/Sustainability

Department Lead: Environmental Services

Last Revised: April 30, 2019

Summary: All County buildings and public facilities shall strive to incorporate the highest environmental performance standards using the LEED, International Living Futures Institute (ILFI), or Viridian’s Earthcraft Virginia green building rating system. This Policy was developed to support Arlington County’s mission of sustainability and to support the County’s overall greenhouse gas reduction goals.

Purpose:

- To reduce operating costs through energy and water efficiency;
- To achieve high-performing, durable, and efficient buildings that are easy to operate and maintain;
- To invest in healthy indoor environments for staff and visitors;
- To demonstrate Arlington’s commitment to environmental, economic, and social stewardship;
- To set a community standard of sustainable building practices.

Scope: Applies to all County Departments and Agencies and their contractors responsible for financing, planning, designing, developing, constructing, renovating, managing, and decommissioning County owned and leased facilities and buildings. This policy applies to new construction and major renovation projects. Incremental improvements to existing buildings should incorporate the Guiding Principles of this Policy, Arlington’s County Operations Energy Plan, and other best management practices when practicable.

Policy Detail:

Guiding Principles. The intent of the following Guiding Principles is to clearly define Arlington County’s sustainability priorities in order to build well-functioning, easy to maintain buildings and facilities with low energy demands and excellent indoor environmental quality.

- 1) **Function** - Achieve high performing and efficient building operations with systems and components that are easy to use and maintain. Ensure the building operates as intended and reduce long-term operating costs:
 - Prioritize simple, passive solutions over mechanical solutions for energy use reduction and stormwater management.
 - Minimize use of complicated sensor and control systems.
 - Design and locate building systems for ease of access and maintenance.
 - Ensure building systems are compatible with the building programming, fully functional and operate as intended before the building is accepted.
 - As new facilities are acquired or built, facilities maintenance budgets should be reassessed and planned.
- 2) **Energy** - Use integrated design and passive strategies to minimize heating, cooling, and lighting loads and reduce long-term operating costs:

- Prioritize the building thermal envelope and right-size mechanical equipment.
 - Use building orientation and daylight devices to evenly distribute daylight.
 - Avoid elements that are solely aesthetic that increase energy use.
 - Optimize solar PV exposure and vegetated roof space.
 - Efficient space utilization.
- 3) **Human Experience** - Support occupant health and well-being with:
- Fresh air and ventilation
 - Humidity control
 - Selection of low-toxicity materials
 - Evenly distributed daylight and minimal glare
- 4) **Durability** - Select quality materials, systems, and equipment to reduce maintenance, operations, and replacement costs:
- County buildings and facilities should be built to last and be flexible in their design to support occupant and community needs as they change over time.
 - Select materials that are easy to maintain and durable for the intended use and expected life of the building
 - Commission all building systems starting at the design phase and test the building enclosure for air and water infiltration

Standards. It shall be the policy of Arlington County to finance, plan, design, construct, manage, renovate, maintain, and decommission its facilities and buildings to be sustainable. As a general principle, all County owned and leased buildings and public facilities construction will strive to incorporate the highest environmental performance standards. The following outlines Arlington County's minimum sustainability targets and does not preclude pursuit of rating systems above and beyond the standards of this policy.

- 1) New County buildings, additions, and major renovations shall be designed and constructed to reduce energy use intensity below 28 kbtu/sq.ft./year and optimize solar exposure to be "Net Zero Energy Ready" as defined below in Definitions. A Power Purchase Agreement may be used to install onsite solar necessary to achieve Net Zero Energy certification through the International Living Futures Institute. Renewable Energy Credits (REC's) should remain on site, if possible.
- 2) Net Zero Energy Ready goals may be waived, as described below in (6) below, if analysis shows sufficient technical constraints such as high density or inherently high energy intensity uses such as aquatic centers or other constraint. *If determined that the project will not pursue Net Zero Energy Ready goals*, then new County buildings, additions, and major renovations will be designed and constructed to operate at or below a site energy use intensity (EUI) based on building type (in kbtu/sq.ft./yr):

Use type	Target Site EUI – New (kbtu/sq.ft./year)	Target Site EUI – Reno (kbtu/sq.ft./year)
Pre-school/Daycare	50	60
K-12 School	44	56
Joint Use	65	78
School with Pool	58	75
Community Center	40	60

Multifamily Housing	55	65
Office	50	60
Fire Station	70	80
Library	35	40
Warehouse	15	30
Other	considered on a case-by-case basis	

- 3) New County buildings, additions, and major renovations eligible for LEED for New Construction certification must achieve at least LEED Silver certification to demonstrate and communicate comprehensive sustainability to the public, including management of energy, water, materials, indoor environment, and sustainable sites. Projects may achieve Viridiant’s Earthcraft Commercial or Residential certification as applicable in lieu of LEED Silver certification.
- 4) Buildings to be constructed or renovated with less than 5,000 sq. ft. GFA, buildings leased by the County with less than 8,000 sq. ft. GFA or an initial lease term 8 years or less, and buildings without climate-control systems may be exempt from these Policy Standards but will follow the Guiding Principles.
- 5) If analysis shows that a major renovation does not include the scope of work necessary to pursue the Net Zero Energy Ready goal, the target energy use intensity, and/or is ineligible for LEED or Earthcraft certification, then it shall be determined that this policy has been met if applicable Guiding Principles have been incorporated.
- 6) Each County project will be evaluated on a case-by-case basis. Waiver of Net Zero Energy Ready goals will be determined by the Director of Environmental Services or designee. Unless the County Manager determines the application of this Policy to a particular building or facility is not in the County’s best interest (for example, because of time urgency or lack of funding), all County buildings and facilities will be constructed or renovated in accordance with this Policy.

Procedures and Responsibilities

- 1) The Directors of all County Departments whose responsibilities include planning, designing, developing, constructing, renovating, managing, and decommissioning County-owned and leased buildings facilities shall be responsible for ensuring that facilities and buildings comply with this Policy.
- 2) Budget planning should include life cycle cost analysis to support implementation of this Policy.
- 3) Include stakeholders in the scoping, design, and construction process *as noted in Attachment I* in order to effectively implement this Policy, including a post occupancy survey to identify lessons learned.
- 4) When selecting design teams, include a competitive preference for design and construction professionals experienced in ultra-low energy buildings.

- 5) Agencies shall include in their calculations for maintenance costs for new or renovated buildings an adjustment in cost per square foot to support new buildings.
- 6) County staff must have LEED and building science training appropriate for their level of involvement in the project/s.

Related Information:
Definitions

Passive Strategies: A set of design principles used to attain a rigorous level of energy efficiency within a specific quantifiable comfort level. Passive design employs continuous insulation throughout the entire building envelope without thermal bridging. The building envelope is very airtight, preventing infiltration of outside air and loss of conditioned air and employs high-performance windows and doors. Solar gain is managed to exploit the sun's energy for heating purposes in the heating season and to minimize overheating during the cooling season. Daylighting is used to reduce demand for electric lighting.

Net Zero Energy Certification and Net Zero Energy Ready: The International Living Future Institute's (ILFI) Zero Energy Building (ZEB) Certification™ was created to allow projects to demonstrate zero energy performance. One hundred percent of the building's energy needs on a net annual basis is supplied by on-site renewable energy. "Net Zero Energy Ready" describes a high performance building so energy efficient that a renewable energy system can offset all or most of its annual energy consumption. It also has been designed for optimum solar exposure and provisions for connecting future solar to the interior electrical system with minimal additional roof penetrations.

LEED: LEED stands for Leadership in Energy and Environmental Design, and is a voluntary, consensus-based, market-driven green building rating system developed by the U. S. Green Building Council (USGBC).

Sustainable Buildings: Sustainable buildings incorporate a variety of practices, building materials and methods that promote environmental quality, economic vitality, and social benefit through the design, construction and operation of the built environment. Sustainable buildings merge sound environmentally responsible practices into one discipline that looks at the environmental, economic and social effects of a building or built project as a whole. Sustainable design encompasses the following broad topics: efficient management of energy and water resources, management of material resources and waste, protection of environmental quality, protection of health and indoor environmental quality, reinforcement of natural systems, and integrating the design approach.

Sustainable buildings are optimally integrated on all parameters— initial affordability, timeliness of completion, net life-cycle cost, durability, functionality for programs and persons, health, comfort, safety, accessibility, beauty, maintainability, energy efficiency, and environmental sustainability. For example, the design team should pursue energy efficiency strategies that don't diminish, but rather enhance health, comfort, safety, and delight of the building occupants.

Site Energy Use Intensity: the annual amount of annual energy per square foot (kbtu/sq.ft./year) delivered to the building by the utility.

Life Cycle Cost Analysis: An inclusive approach to costing a program, facility, or group of facilities that encompasses planning, design, construction, operation and maintenance over the useful life of the facilities and finally any decommissioning or disassembly costs. Life Cycle Cost Analysis looks at the net present value of design options as investments. The goal is to achieve the highest, most cost-effective environmental performance possible over the life of the project.

Major Renovation: Typically, the extent and nature of the work is such that the space cannot be fully occupied and equipment cannot be used for its intended purpose while the work is in progress. Often times, a new certificate of occupancy is required before the work area can be reoccupied. Major renovations include extensive alteration work in addition to two or more of the following: interior fit-out, work on the exterior shell of the building, work on primary structural components, work on the core and peripheral MEP and service systems.

History/Background:

The Policy for Integrated Facility Sustainability (a.k.a. The Green Building Policy) was originally adopted in 2008, and the corresponding Administrative Regulation was approved in 2009, to address design and construction, and to maintain comprehensively high-performance sustainable buildings. Since then a number of forces have led to a need for a policy update including:

- Community Energy Plan adoption
- Maturation of green building industry, evolution of best practices, and broad market adoption
- Net Zero Energy certification possible and practical

An interdepartmental working group was convened in October 2017 and met monthly to revise the policy using a consensus building model.

Future Policy Considerations:

Consider energy use, occupant health, and comfort issues when acquiring new buildings or leasing space in existing buildings. For each building acquired for occupancy, complete an energy assessment to determine historic energy use and the extent of building deficiencies. When major deficiencies do exist, develop a plan for upgrading the building to meet the sustainability targets of this policy. Deconstruct deficient facilities acquired in land banking acquisitions that are not intended for occupancy.

Consider a preference for purchasing or leasing space in buildings that meet any of the energy and sustainability targets in this policy.

Effective 11-30-2009

Revised 4-30-2019

Authored by: Jessica Abralind, DES Office of Sustainability and Environmental Management

Approved:  
Mark Schwartz, County Manager Date

Attachment I – Implementation of the Facility Sustainability Policy

Sustainability Stakeholders

PM – Project Manager in FDC, FMB, or DPR

Energy – Arlington Initiative to Rethink Energy

Program staff - DPR, FIRE, etc

FM – Facilities Maintenance

Community – E2C2 (EA 4.4)

This diagram is intended to illustrate how the project manager (PM) can involve stakeholders to best implement the Facility Sustainability Policy.

Prior to project conception the PM and Energy team will work together to review the scope of work to determine the applicability of the policy and inform the project’s procurement documents. Throughout the project, the PM, Energy team, FM, and Program staff works together to ensure sustainability goals, operational needs, and program needs are satisfied.

After project completion, the PM will complete a post-occupancy survey and work with FM, program staff, and the Energy team to identify lessons learned and inform new project developments.





EarthCraft House Technical Guidelines

Version 2.0

July 2018

Table of Contents

Introduction	3
Certification Process	5
Site Planning (SP)	10
Resource Efficiency (RE)	17
Durability and Moisture Management (DU)	27
High Performance Building Envelope (BE)	41
Energy Efficient HVAC System (ES)	54
Indoor Air Quality (IAQ)	74
Plumbing and Irrigation (PI)	91
Lighting and Appliances (LA)	103
Education and Operations (EO)	108

Introduction

The EarthCraft House Technical Guidelines apply to all new construction and gut rehab projects in the EarthCraft House program, including single-family homes, duplexes, and townhomes. When verifying items for an EarthCraft project, EarthCraft Builders and EarthCraft Technical Advisors shall reference these Guidelines to ensure all requirements have been met.

If local building codes conflict with or are more stringent than the EarthCraft Technical Guidelines, the local code shall be followed. The Builder must notify the Technical Advisor of any changes required for the home to meet local codes.

Materials and methods described are representative of typical strategies that meet the intent of the criteria, but do not represent all strategies that may be used. The project team may request permission from EarthCraft to meet the intent of the credit using a different approach. Approval from EarthCraft must be obtained prior to implementation.

The EarthCraft House Program

The EarthCraft House program prioritizes resource efficiency and smart construction practices. It is organized into primary categories, each of which details specific criteria. The primary categories are:

SITE PLANNING	SP
RESOURCE EFFICIENCY	RE
DURABILITY & MOISTURE MANAGEMENT	DU
HIGH-PERFORMANCE BUILDING ENVELOPE	BE
ENERGY-EFFICIENT HVAC SYSTEMS	ES
INDOOR AIR QUALITY	IAQ
PLUMBING & IRRIGATION	PI
EFFICIENT LIGHTING & APPLIANCES	LA

EarthCraft's base level certification is called EarthCraft certified. An EarthCraft certified home is an energy efficient home that meets code requirements for envelope specifications and is above code on envelope performance and indoor air quality (IAQ).

Projects seeking to further distinguish themselves for building performance, environmental awareness, and/or occupant health and safety may seek additional certification packages. These packages, or certification badges, fall into four (4) categories:

COMFORT	CMFT
ENVIRONMENT	ENV
HEALTH	HLTH
PERFORMANCE	PERF

Badges are optional add-ons for any EarthCraft certified project. Each has its own requirements that projects must meet in order to obtain the badge. Since these badges serve to enhance different areas of the EarthCraft House program, their specific requirements may be distributed within multiple sections of the EarthCraft House worksheet. The table below highlights the areas each badge enhances:

	<p>The Comfort badge includes advanced heating and cooling systems, including high efficient equipment, advanced distribution design and commissioning of systems. All items covered by the Comfort badge are located within the Energy Efficient Systems section of the EarthCraft House worksheet.</p>
	<p>The Health badge includes high performance outdoor air ventilation systems and increased attention to finish materials. All of the items covered by the Health badge are located within the Indoor Air Quality section of the EarthCraft House worksheet.</p>
	<p>The Environment badge includes site design and material selection items that support environmentally preferred construction practices. This badge covers the following areas of the EarthCraft House worksheet: Site Planning, Resource Efficiency, and Plumbing & Irrigation.</p>
	<p>The Performance badge supports building construction practices and materials supporting a residential structure exceeding the IECC 2015 energy code for energy and water efficiency. This badge requires that projects complete an energy model to aid the design team as they plan a high performance home. The Performance badge covers the following areas of the EarthCraft House worksheet: High Performance Building Envelope and Plumbing & Irrigation.</p>

Certification Process

1. Project Eligibility

Projects that meet the below criteria are eligible for EarthCraft House certification:

- A. Single-Family detached
 - New construction, built upon a new or existing foundation
 - Ancillary structures that are intended to be habitable and share the same address as the primary house, such as a guest house or a suite above a garage, will be subject to the same criteria as the primary house
- B. Townhome, row home or duplex
 - Each dwelling unit must have its own unique postal address
 - Each dwelling unit will be registered as an individual project

Builder Responsibilities

Determine project eligibility

- Contact EarthCraft if you are uncertain which EarthCraft program your project qualifies for.

2. Registration

Projects that meet the above criteria are eligible for EarthCraft House certification. To initiate a new EarthCraft project, a project registration form must be completed. A project may be registered by any individual involved with the project. The registration fee must be paid in full before certification will be awarded.

Builder Responsibilities

Select a Technical Advisor (TA)

- The TA will track the project throughout the certification process and provide all EarthCraft verification, diagnostic testing, and energy modeling services as they apply to the certification path selected by the builder.

If assigning registration responsibility to the Technical Advisor or another representative from the builder company, provide registrant with all of the information needed to complete the registration form:

- Building type
- Conditioned square footage
- Number of stories
- Number of bedrooms
- Project address
- Billing contact
- Permit date

Technical Advisor Responsibilities

Ensure the project has been registered with EarthCraft

- A project must be registered with EarthCraft prior to the completion of the mid-construction review

3. Design Review

The Design Review is an opportunity to identify project goals and ensure measures are in place to meet all of the criteria set by EarthCraft. If applicable, the preliminary energy model will be used to estimate performance and determine if any improvements are needed to achieve the performance badge.

Builder Responsibilities

Send the following documents to the Technical Advisor for review:

- Completed construction specification sheet demonstrating how the project will meet EarthCraft requirements
- Project worksheet that lists which requirements will be applicable and which optional badges will be pursued, if any
- Manual J load calculations and Manual S equipment selection
- Drawings and specifications
- Note any questions about program technical requirements so that potential issues may be resolved during the design phase of the project

Technical Advisor Responsibilities

Review all materials provided by the Builder

- Determine the project's ability to achieve certification
 - If necessary, develop options to meet program criteria
- Address all questions and concerns presented by the Builder
 - Contact EarthCraft if further clarification is needed
- Identify effective cost trade-offs for improving building performance
- Identify areas of potential confusion or failure
- If applicable, complete preliminary energy model

4. Mid-Construction Review

During the mid-construction review, the TA will begin to gather verification documentation and conduct the mid-construction inspection(s).

Builder Responsibilities

Schedule the initial mid-construction inspection with your TA

- At least one (1) inspection must occur after insulation installation, but prior to the hanging of drywall
- Ensure the project is ready for inspection
 - Framing, rough-in, air sealing, and insulation installation must be complete and ready for visual inspection
 - The TA must be able to visually verify that framing, air sealing and insulation requirements have been met

Note: The minimum insulation installation that should be installed during the mid-construction review is for exterior wall insulation. If necessary, the TA may visually inspect attic and floor insulation during a final inspection. Builders shall discuss when all areas of insulation will be inspected with their TA during the design review, or prior to completing all inspections during the mid-construction review.

Technical Advisor Responsibilities

Follow up with Builder to ensure the inspection is scheduled during the appropriate time of construction

Perform the inspection

- Verify applicable worksheet items
- Confirm the Manual J reflects the home as constructed
- If applicable, confirm the energy model represents the home as constructed

Inform the Builder whether or not the project passed inspection

- If necessary, outline items that need correction or further attention

5. Final Review

As construction activities near completion, the Technical Advisor will verify all remaining worksheet items and conduct final diagnostic testing.

Builder Responsibilities

Schedule the final inspection with your TA

- Inspection shall occur after all interior finishing work has been completed, but prior to occupancy

Ensure the project is ready for inspection

- All unverified worksheet items must be completed and accessible

Technical Advisor Responsibilities

Follow up with Builder to ensure the inspection is scheduled during the appropriate time of construction

Perform the inspection

- Conduct diagnostic testing
- Verify applicable worksheet items
- If applicable, confirm the energy model represents the home as constructed

Inform the Builder whether or not the project passed inspection

- If necessary, outline items that need correction or further attention

6. Certification

At certification the TA will provide EarthCraft with all documentation necessary for review. After EarthCraft has reviewed and accepted all documentation, the certificate will be awarded.

Technical Advisor Responsibilities

Complete the inspection report and submit to EarthCraft for review

- This must be completed no later than forty-five (45) days after the first final inspection

Assemble the certification submittal package

- Final worksheet
- Worksheet cover, signed by builder and TA
- Projects showing compliance through an energy model* must submit:
 - Home Energy Rating Certificate (HERS Certificate)
 - 2009 IECC Fuel Summary Report

*Energy models must be confirmed by the provider prior to submitting to EarthCraft.

*Reports without print permission or not listed as confirmed will not be accepted

Submit all submittal documents to EarthCraft

- This must be completed no later than forty-five (45) days after the first final inspection

Site Planning (SP)

The location of a home and the plan for the area around that home can have a significant impact on both a resident's quality of life and on the environment. Selecting an appropriate site for a home is essential to creating more walkable, livable communities. One can also improve the air quality in a neighborhood, help manage storm water, lower energy bills, and increase property values simply by protecting and restoring trees on a site. Planning for construction on a site can prevent soil loss and water pollution by reducing erosion and properly controlling for storm water.

The Site Planning category of the EarthCraft program focuses on actions that a builder can take to minimize the direct impact of a building site on the environment. These actions range from protecting excavated topsoil from erosion to reducing lot size.

SP 1: Do not install invasive plant species

Purpose

Invasive species are region-specific, non-native plants that tend to spread aggressively and decrease native biodiversity.

Criteria

Invasive species are region-specific, non-native plants that tend to spread aggressively and decrease native biodiversity. Do not include plants on the landscape plan that have been identified as non-native, invasive Category 1-2 species (also may be called Severe Threat or Significant Threat), with the exception of Bermuda grass (*Cynodon dactylon*).

Additional Resources

For an up-to-date list of invasive species and associated categories for projects located in the Southeast please refer to the resources below:

- Alabama:
 - Alabama Invasive Plant Council: <https://www.invasive.org/species/list.cfm?id=71>
- Georgia:
 - Georgia Exotic Pest Plant Council: <https://www.gaepcc.org/list/>
- North Carolina:
 - North Carolina Native Plant Society
https://www.ncwildflower.org/plant_galleries/invasives_list
- South Carolina:
 - South Carolina Exotic Pest Plant Council: <https://www.se-epcc.org/southcarolina/invasivePlants.cfm>
- Tennessee:
 - Tennessee Invasive Plant Council: <http://tnipc.org/invasive-plants/>
- Virginia:
 - Virginia Department of Conservation and Recreation:
<http://www.dcr.virginia.gov/natural-heritage/invspdflist>

Confirmation

The EarthCraft Technical Advisor will confirm compliance based on plant list provided by the builder prior to submitting project for certification.

Example

Miscanthus Sinensis is a Category 2 invasive species in Georgia and is not allowed to be planted on an EarthCraft House project built in Georgia.

SHRUBS				
KEY	BOTANICAL NAME / COMMON NAME	SIZE	SPACING	QTY.
⊗	BUXUS MICROPHYLLA VAR. KOREANA 'WINTERGREEN' / KOREAN BOXWOOD	3 GAL.	30" O.C.	170
⊙	BUXUS MICROPHYLLA VAR. KOREANA 'WINTERGREEN' / KOREAN BOXWOOD	5 GAL.	AS INDICATED	3
⊗	GARDENIA JASMINOIDES 'AUGUST BEAUTY' / AUGUST BEAUTY GARDENIA	3 GAL.	5' O.C.	72
⊗	GARDENIA JASMINOIDES 'RADICANS' / DWARF GARDENIAS	3 GAL.	30" O.C.	128
⊗	HYDRANGEA MACROPHYLLA 'BAILMER P.P. #15,298' / ENDLESS SUMMER HYDRANGEA	3 GAL.	30" O.C.	38
⊗	HYDRANGEA QUERCIFOLIA 'PEEWEE' / OAKLEAF HYDRANGEA	3 GAL.	3' O.C.	81
⊗	ILLICIUM PARVIFLORUM / ANISE	3 GAL.	4' O.C.	179
⊗	ITEA VIRGINICA 'HENRY'S GARNET' / VIRGINIA SWEETSPIRE	3 GAL.	3' O.C.	184
⊗	MISCANTHUS SINENSIS 'MORNING LIGHT' / MAIDEN GRASS	3 GAL.	3' O.C.	54
⊗	PRUNUS LAUROCERASUS 'OTTO LUYKEN' / OTTO LUYKEN LAUREL	3 GAL.	3' O.C.	16
⊗	ROSA 'RADAZZ' / KNOCKOUT ROSE	3 GAL.	3' O.C.	66
⊗	ROSMARINUS OFFICINALIS / ROSEMARY	3 GAL.	18" O.C.	5

SP 2: Design and Implement Tree Protection Plan

Purpose

Any activity that changes the soil conditions, or disturbs branches, trunks, or root systems, is extremely detrimental to a tree's health. A tree protection plan outlines the steps that will be taken to preserve trees and critical root zones.

Criteria

A professional landscape architect or certified arborist shall develop a tree preservation site plan prior to clearing, grading, or commencement of construction activities that identifies existing trees with diameter at breast height (DBH) dimensions exceeding 3" and designates $\geq 20\%$ of those trees to be protected during all construction activities.

Tree root zones (area extending in all directions from the trunk) must be protected with a physical barrier to minimize all disturbances, including those from parked vehicles and construction material storage. Set fences firmly; if wood fences are used, they must be a minimum of 2x2 lumber. Do not place any soil from clearing, grading, or construction activity on top of any root zone for trees designated on a site plan to be preserved. Trees that are marked to be preserved on a site plan and for which utilities must pass through the root zones must not have surface dug trenches. Dig tunnels through the root zone in order to minimize root damage.

The builder must review tree preservation plan with subcontractors and post plan on job site.

Confirmation

The builder must present documentation demonstrating compliance of criteria to the EarthCraft Technical Advisor during the design review process.

The EarthCraft Technical Advisor will review documentation provided by the builder and will visually confirm compliance during the mid-construction and final inspections.

Examples:



Figure 1: Tunnel to minimize root damage (left) as opposed to surface-dug trenches in root zone (right)

Incorrect



Storage or staging of materials on tree root zones is not permitted

ENV 1: Remove 100% of invasive plants from 100% of site

Purpose

Invasive plant species spread quickly and displace native plants, which may cause economic or environmental harm, or harm to human health.

Criteria

All existing plants that are listed in Category 1 or 2, Severe Threat or Significant Threat, or High or Medium (with the exception of Bermuda grass) must be removed and properly disposed of.

Additional Resources

For an up-to-date list of invasive species and associated categories for projects located in the Southeast please refer to the resources below:

- Alabama:
 - Alabama Invasive Plant Council: <https://www.invasive.org/species/list.cfm?id=71>
- Georgia:
 - Georgia Exotic Pest Plant Council: <https://www.gaeppc.org/list/>
- North Carolina:
 - North Carolina Native Plant Society
https://www.ncwildflower.org/plant_galleries/invasives_list
- South Carolina:
 - South Carolina Exotic Pest Plant Council: <https://www.se-eppc.org/southcarolina/invasivePlants.cfm>
- Tennessee:
 - Tennessee Invasive Plant Council: <http://tnipc.org/invasive-plants/>
- Virginia:
 - Virginia Department of Conservation and Recreation:
<http://www.dcr.virginia.gov/natural-heritage/invspdflist>

Confirmation

- The builder must present documentation demonstrating compliance of criteria to the TA prior to submitting project for certification.
- The Technical Advisor will review documentation provided by the builder for compliance.

ENV 2: Permanent stormwater control $\geq 50\%$ of onsite impervious surface areas

Purpose

Impervious surface runoff should be properly located to drain away from building foundation in order to protect the home from moisture damage.

Criteria

Control disturbed site area by integrating Low Impact Development Best Management Practices (LID BMP) into the project. All BMPs shall be properly located to drain away from building foundation to protect home from moisture damage.

Projects must disconnect at least 50% of onsite impervious surface areas from storm drains by implementing some or all of the LID BMPs from the list below:

1. Direct impervious surface runoff to appropriately sized rain gardens, swales, drywells or bio-retention areas. Receiving area soils shall be amended to increase infiltration to the level required for maintaining storm water. Keep area protected from heavy machinery and parking during construction or mitigate soil compaction post construction.
2. Design and install rooftop gardens and/or green roofs.
3. Direct roof or site runoff into rain barrels and/or cisterns. Size barrels and cisterns appropriately and enable use of water for building reuse or landscape irrigation.

Additional Resources

- Low Impact Development (LID) Urban Design Tools Website
- Local jurisdiction's Stormwater Management Manual
- National Resource Defense Council Water Smart Cities

Confirmation

The EarthCraft Technical Advisor will visually confirm compliance of criteria at final inspection.

ENV 3: Reduce irrigated area and install drought tolerant landscaping (both, details below):

- Turf \leq 40% of landscape area
- Drought-tolerant and/or native landscaping turf and plants

Purpose

Minimizing or eliminating lawns and integrating drought tolerant landscaping saves water and energy and reduces the amount of fertilizers that pollute waterways.

Criteria

When irrigation is installed, design the irrigated area with \leq 40% turf. For all landscaped areas, whether or not irrigation is present, use drought-tolerant and/or native species for at least 75% of the plantings.

Additional Resources

Information regarding native and/or non-invasive plant species for projects located in the Southeast may be found from the resources below:

- Alabama:
 - Alabama Cooperative Extension System: <http://www.aces.edu/home-garden/lawn-garden/>
- Georgia:
 - Georgia Native Plant Society: <https://gnps.org/>
- North Carolina:
 - North Carolina Native Plant Society
https://ncwildflower.org/native_plants/recommendations
- South Carolina:
 - South Carolina Native Plant Society: <http://scnps.org/>
- Tennessee:
 - Tennessee Native Plant Society: <http://tnps.org/resources.html>
- Virginia:
 - Virginia Department of Conservation and Recreation:
<http://www.dcr.virginia.gov/natural-heritage/nativeplants>

Confirmation

- The builder must provide a plant list with the types of plants installed, quantity of each, water needs of each, and which are native species.
- The EarthCraft Technical Advisor will visually confirm compliance of criteria at final inspection.

Resource Efficiency (RE)

Forests provide habitats to diverse animal species, offer watershed protection, prevent soil erosion and help maintain the water cycle. EarthCraft House encourages the protection of forests through resource efficient design. By taking the time to design a home to use less wood and by practicing simple measures to ensure that wood on site is used properly, a new home can reduce its impact the environment as well as cost less money to build.

EarthCraft projects can meet the requirements of the Resource Efficiency category through methods such as employing advanced framing techniques and providing clear framing plans and cut lists to contractors. These methods not only reduce the amount of lumber used on site, but also save money through reduced material costs, reduced tipping fees, and increased customer satisfaction including improving the home's energy efficiency.

Building materials come from a variety of sources, not all of which are environmentally friendly. The EarthCraft program strives to reduce the impact homes have on the environment, including the impacts that result from the extraction and manufacture of materials used in home construction. By choosing certain building materials, an EarthCraft Builder can conserve natural resources, prevent unnecessary waste and reduce pollution associated with manufacturing and transporting of materials.

RE 1: Minimum stud spacing: 16" centers for 2x4 walls and 2x6 walls

- 16" centers for 2x4 walls and 2x6 walls
- Wall spacing at 24" centers for non-load bearing walls

Purpose

Using the minimum amount of wall studs (and eliminating studs that lack a structural purpose) reduces thermal bridging and allows more space for insulation in addition to conserving lumber.

Criteria

Exterior and load-bearing walls: Minimum stud spacing at 16" centers for 2x4 and 2x6 walls, unless construction documents specify that alternate spacing is structurally required. No more than 5% of studs may lack a structural purpose.

Non-load-bearing walls: minimum stud spacing at 24" centers for 2x4 and 2x6 walls, unless construction documents specify that alternate spacing is structurally required.

The builder must present construction documents demonstrating structural requirements for excess framing greater than 5%.

Confirmation

The EarthCraft Technical Advisor will visually confirm compliance of criteria at mid-construction inspection.

Example

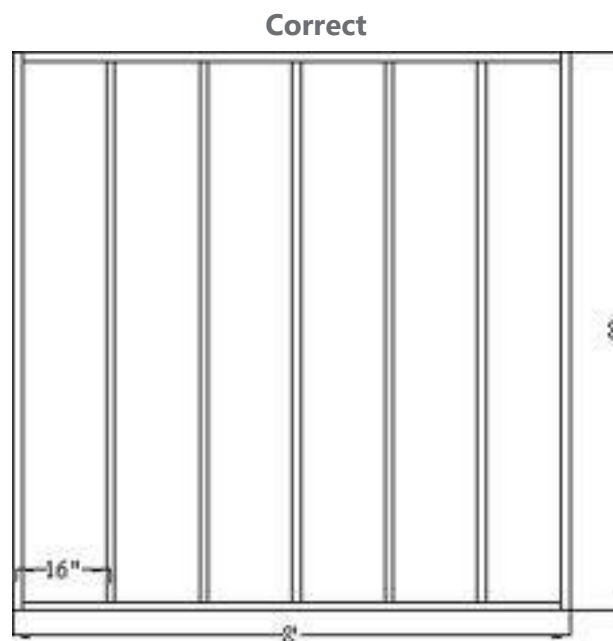

Construct load-bearing walls with 16 inch on center (OC) stud spacing for 2x4 and 2x6 framing.

RE 2: Size headers for loads (non-structural headers in non-load bearing walls)

Purpose

Minimize waste by designing and installing appropriately sized headers in all walls. Headers should be sized to accommodate the correct load.

Criteria

Design and install appropriately sized headers in all walls. Eliminate load bearing headers in all non-load bearing walls and do not size all headers in load bearing walls to accommodate the greatest load case.

Clarification

Consult local building codes in areas susceptible to high wind or seismic regions.

Confirmation

The EarthCraft Technical Advisor will visually confirm compliance of criteria at mid-construction inspection and collect supporting documentation, if necessary.

RE 3: Energy heel truss system or raised top-plates for all vented, unconditioned attics

Purpose

Raised heel, energy trusses extend further past the wall and are deeper at the wall, thus allowing room for full insulation coverage over the top plate of the exterior walls.

Criteria

Install energy heel trusses or raised top plates to ensure full depth of attic insulation above exterior wall top plates. Depth of insulation above top plate may be traded to R-21 when allowed by code.

Confirmation

The EarthCraft Technical Advisor will visually confirm compliance of criteria at mid-construction inspection.

RE 4: If HVAC ductwork is in conditioned attic, attic side radiant barrier

Purpose

Unconditioned attics are significantly hotter in the summer than the air being carried in the HVAC ductwork. Radiant barriers reduce the temperature of the attic by reflecting radiant heat instead of absorbing it.

Criteria

If more than 10 linear feet of ductwork are located in an unconditioned attic, install a radiant barrier with a minimum initial reflectance of 0.90 and maximum initial emittance of 0.10 on all sloped roofs above vented attics. Install radiant barrier so that foil is facing down and not in direct contact with any building materials other than roof rafters. Any uninsulated attic surfaces must have a radiant barrier installed. This includes sloped roof decks as well as gable end walls.

Confirmation

- Builder shall provide documentation of materials selected to TA prior to submitting project for certification.
- The EarthCraft Technical Advisor will visually confirm compliance of criteria at pre-drywall and final inspections

RE 5: Engineered trim

- Interior and exterior $\geq 75\%$

Purpose

Engineered products offer both resource and durability benefits when compared to traditional wood products by resisting rot when exposed to elements (exterior) and are a more effective use of resources.

Criteria

Install a minimum of 75% of total exterior and interior trim from non-solid sawn wood (e.g., finger-jointed wood, medium or high-density fiber board (MDF or HDF), etc.), or non-wood material, such as PVC. All non-solid sawn wood. Products selected must have low or no added urea-formaldehyde.

Clarification

Stain grade trim does not count towards percentage of trim material covered by this criteria.

Confirmation

- Builder shall provide documentation of materials selected to TA prior to submitting project for certification.
- The EarthCraft Technical Advisor will visually confirm compliance of criteria at mid-construction and final inspections

ENV 4: Advanced framing package (choose one, details below):

- Deliver panelized construction or SIPS to the site pre-framed
- Site framing plan with precut framing package

Purpose

Advanced framing results in savings on materials costs to builders, reduces the amount of labor needed for installation, and reduces environmental impact due to more strategic cutting of material and reduces thermal bridging.

Criteria

Review complete framing plan and framing package with framing contractor to reduce unnecessary framing. The framing plan must illustrate the location and size of every stud, cripple, plate, header, and other framing members in the roof, walls, and floors. The precut framing package must correspond directly with framing plan.

1. Floors

Construct a minimum of 90% of the floor area using a panelized floor system (e.g., structurally insulated panels) delivered to the jobsite pre-framed and precut. In all cases, install panelized floor according to manufacturer specifications.

2. Exterior walls

Construct a minimum of 90% of all walls separating conditioned space from unconditioned space using panelized wall systems (e.g., structurally insulated panels) delivered to the jobsite pre-framed and precut. In all cases, install panelized walls according to manufacturer specifications.

3. Roof

Construct a minimum of 90% of the roof area using a panelized roof system (e.g., structurally insulated panels) delivered to the jobsite pre-framed and precut. In all cases, install panelized roof according to manufacturer specifications.

Clarifications

- Thermal mass and infiltration effects may not be included in R-value.
- Floor area must be calculated using RESNET standards for conditioned floor area.

Confirmation

- The builder shall provide all necessary framing documentation to the TA prior to the mid-construction inspection
- The EarthCraft Technical Advisor will visually confirm compliance during the mid-construction inspection

ENV 5: Recycled content materials (choose two, details below):

- Replace > 25% of cement in slab and/or foundation wall concrete with fly ash or slag
- Install >50% recycled content insulation
- Install >50% recycled content carpet on >50% of all carpeted floor

Purpose

Recycled content materials lower the overall embodied energy of a project. For example, some recycled materials, such as concrete, require less energy to make than their "virgin" counterparts. Fly ash and slag are also byproducts of coal production/energy use. By removing them from the waste stream and finding a way to repurpose these byproducts, the environmental impact of the concrete is reduced.

Selecting insulation that contains a significant percentage of recycled content allows for material reuse and recovery while diverting materials that would otherwise be destined for landfills.

Selecting flooring with recycled content achieves this goal in a similar manner.

Criteria

- Replace $\geq 25\%$ of the cement with fly ash or slag in all concrete used for footings, foundation and basement walls and slabs.
- Install 100% of insulation with $\geq 50\%$ recycled material (pre or post-consumer) content by weight or volume in all walls, floors and ceilings.
- Install carpet with $\geq 50\%$ recycled content (pre or post-consumer) on 50% of carpet floor area.

Clarifications

Floor area must be calculated using RESNET standards for conditioned floor area.

Confirmation

- The builder shall provide documentation demonstrating compliance of criteria for cement and/or insulation (as applicable to project) to the TA prior to the mid-construction inspection. Builder shall provide documentation demonstrating compliance of criteria for carpet to the TA prior to submitting project for certification.
- The EarthCraft Technical Advisor will review documentation provided by the builder for compliance of criteria.

ENV 6: Responsible waste disposal

- Develop and post waste management plan and divert >75% from landfill (details below):
 - Wood
 - Drywall
 - Mill cleared logs

Purpose

Responsible waste management is an essential component to reducing job-site waste. By posting it on the job site, a project may ensure that the plan will be followed throughout the entire construction process by all on-site staff and trade contractors.

Criteria

Post a construction waste management plan onsite, educate each subcontractor on the aspects of the plan that pertains to their work, and enforce these measures. The waste management plan must either provide for onsite separation of materials to be recycled or provide for separation of recyclable materials by clean-up or waste hauling firms. Maintain documentation on diversion rate for each material.

1. Wood

Avoid disposal of a minimum of 75% (by weight or volume) of solid sawn wood by recycling through a state or county approved program or by on-site grinding and application of wood chips as mulch. Pressure treated wood is exempt from this requirement and may not be milled or applied as mulch.

2. Drywall

Avoid disposal of a minimum of 75% (by weight or volume) of drywall generated from construction through an approved recycling program, or by onsite grinding and application of drywall as a soil amendment.

3. Mill cleared logs

Commercially process 100% of logs that meet sawmill standards into lumber, pulp, or other use. Logs cannot be buried in a landfill or chipped.

Additional Resources

For the NAHB Research Center's "Builder's Field Guide to Residential Construction Waste Management" publication see [here](#).

Confirmation

- The builder must present documentation demonstrating compliance of criteria to the EarthCraft Technical Advisor prior to submitting project for certification
- The EarthCraft Technical Advisor will review documentation provided by the builder for compliance and will visually confirm compliance during the mid-construction inspection.

Durability and Moisture Management (DU)

An important aspect of building a sustainable home is ensuring durability throughout its life cycle. EarthCraft House recognizes that proper design and installation are integral to building a durable home with minimal moisture management issues. Reducing the life cycle costs due to maintenance, repair, and replacement decreases the impact that home construction, and reconstruction, have on the environment. The durability and moisture management section includes items that improve long-term durability and occupant health and comfort.

DU 1: Do not install wet or water-damaged building materials

Purpose

Moisture can cause long term damage to building materials. In particular, wood products swell when they take on moisture and this change in dimension can create problems during installation. Additionally, water may weaken adhesive bonds.

High moisture content can also promote the growth of mold. Installing moldy materials in a building, or failing to properly treat building components that become wet, can expose buildings to potential structural weakness and/or poor indoor air quality when the structure is occupied.

Criteria

Do not install building materials that have visible signs of water damage or mold.

Clarifications

Do not enclose walls if the framing members or the insulation has high moisture content (framing members shall be dried to at least 18% moisture content). Follow the manufacturer's drying recommendations for wet-applied insulation and test framing members for moisture prior to enclosing wall cavities.

Confirmation

The EarthCraft Technical Advisor will visually confirm compliance of criteria at mid-construction inspection.

If high moisture or mold is found during the mid-construction inspection, the builder must present documentation demonstrating compliance of criteria to the EarthCraft Technical Advisor. Documentation may include moisture content test results, mold remediation invoices/reports or the equivalent.

Example

Incorrect



Do not install wet building materials. If materials are exposed to moisture after installation, drain/dry area and treat for mold as necessary.

DU 2: Crawlspace, if designed (choose one, details below):

- Vented crawlspace with spray foam insulation covering 100% of framed floor and 100% coverage of sealed ≥ 6 mil vapor barrier over exposed earth. Vapor barrier shall extend ≥ 6 " up the stem wall and shall be attached and sealed to the stem wall.

OR

- Unvented crawlspace meeting IRC 2012 (Details below):
 - I. Exposed earth is covered with a continuous ≥ 6 mil vapor barrier. Joints of the vapor barrier shall overlap by 6" and shall be sealed. The edges of the vapor retarder shall extend ≥ 6 " up the stem wall and shall be attached and sealed to the stem wall or insulation; and
 - II. One of the following is provided for under the under-floor space:
 - a. Continuously operated mechanical exhaust ventilation at a rate equal to 1 cubic foot per minute for each 50 square feet of crawlspace floor area, including an air pathway to the common area (such as a duct or transfer grill) and perimeter walls insulated in accordance with EarthCraft criteria or local code, whichever is more stringent
 - b. Conditioned air supply sized to deliver at a rate equal to 1 cubic foot per minute for each 50 square feet of under-floor area, including a return air pathway to the common area (such as a duct or transfer grill) and perimeter walls insulated in accordance with EarthCraft criteria or local code, whichever is more stringent

Purpose

Traditional vented crawlspaces are known sources of moisture that can result in damage to framing members and introduce pollutants to living spaces. If a crawlspace is included in the design of a home it should be designed in a way that separates the area from moisture sources and provides for treatment of the area for moisture and humidity.

Properly unvented crawlspaces keep out unwanted moisture better than conventional, wall-vented crawlspaces in temperate-humid climates. Homes with closed crawlspaces (aka "sealed," "unvented," or "conditioned") also can save significantly on energy when compared to homes with wall-vented crawlspaces because they reduce energy loss through the floor of a building.

Properly installed crawlspace ground vapor barriers in all crawlspace areas will prevent the accumulation of ground moisture and soil gases in the crawl space.

Criteria

See above crawlspace design and construction requirements language and reference the IRC 2012 for additional information.

Clarifications

- Not required if project is located in 100 year flood plain.
- Drainage, pests and combustion safety issues are important considerations when sealing a crawlspace.

Additional Resources

For more information about sealed crawlspaces, refer to the Advanced Energy's research on crawlspaces: http://www.advancedenergy.org/portal/crawl_spaces/.

Confirmation

- The EarthCraft Technical Advisor will review plans with builder, and if necessary the HVAC contractor, during design review to confirm foundation design.
- TA will verify compliance of foundation space during the mid-construction and final inspections.

Examples

Correct



Follow IRC 2012 for strategies on designing and constructing a closed crawlspace. Closed crawlspaces should have a properly installed vapor barrier, insulation on the crawlspace wall, and a method for providing dehumidification to the space.

Correct



Floor insulation of SPF that covers 100% of framed floor, with a properly installed vapor barrier covering 100% of exposed dirt floor is permitted.

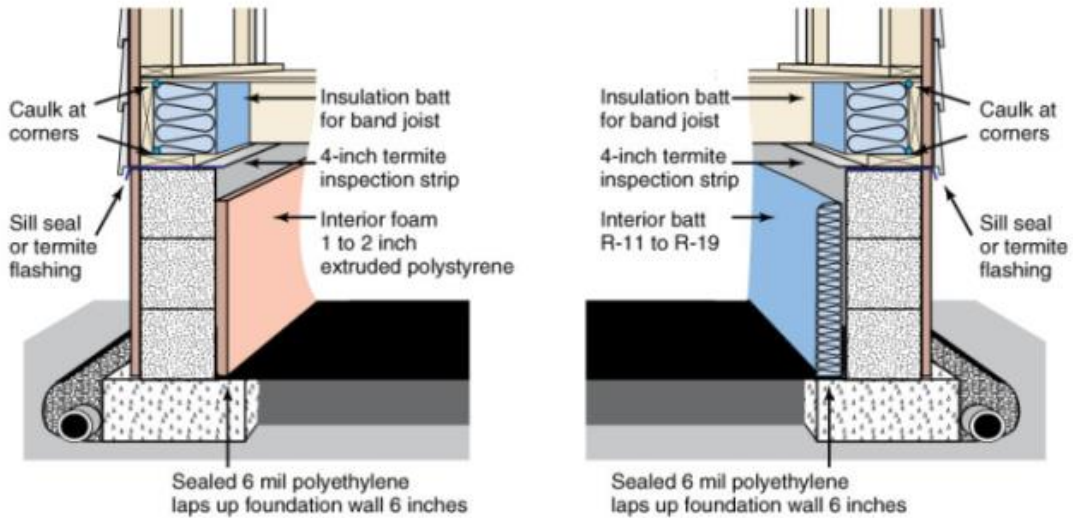

Diagram demonstrating options for creating a sealed, conditioned crawlspace. The image on the left shows foam board attached to the foundation wall, with additional insulation material in the band joist. The image on the right shows batt insulation material attached to the foundation wall, with additional insulation material in the band joist.

In both images the soil in the foundation space is covered with a continuous ≥ 6 mil vapor barrier that is 100% sealed at extends vertically on the foundation wall to a minimum of 6" above grade.

DU 3: Slabs, if designed (both, details below):

- 100% coverage of ≥ 6 mil vapor barrier beneath all slab
- Gravel bed beneath all slabs (exception: Climate Zone 2)

Purpose

A vapor barrier serves to prevent water vapor and soil gases from coming into contact with the concrete slab. Gravel beds allow for groundwater drainage and can act as a capillary break and prevent groundwater from coming in contact with the slab.

Criteria

Install a ≥ 6 mil vapor barrier beneath all slabs to prevent soil moisture and gases from entering the home. Provide 100% coverage. Overlap and seal all vapor barrier joints a minimum of 6".

Install a ≥ 4 " deep gravel bed (consisting of ≥ 0.5 " clean aggregate with no fines beneath on-grade or raised concrete floor slabs (not required if project is located in Climate Zone 2).

Clarifications

Gravel bed must be installed beneath vapor barrier. If gravel is not available, install a ≥ 4 " of uniform layer of sand with geotextile drainage matting.

Confirmation

- The builder will illustrate compliance of criteria through photo documentation submitted to the EarthCraft Technical Advisor prior to mid-construction inspection.
- The EarthCraft Technical Advisor will review photo documentation provided by the builder for compliance of criteria.

Examples

Correct



Install a continuous vapor barrier of ≥ 6 mil plastic prior to pouring slab.

Correct



DU 4: Bottom of foundation drain no higher than top of subgrade footing

Purpose

Foundation drains capture and direct water away from the foundation walls and footings and help to ensure low levels of soil saturation. Increased hydrostatic pressure on the footing/foundation can cause excess stress on the joints of the foundation.

Criteria

Install a protected foundation drain tile outside of the footing or, at the highest point, directly on top of the footing. Use appropriate drain elbows for bends to prevent drainage constriction around corners. Surround each pipe with ≥ 6 " of 1/2" - 3/4" gravel and wrap gravel layer fully with fabric cloth. Discharge all drain lines either away and downhill from the foundation to outside grade/daylight, drywell or to a sump pump.

Clarifications

- Place the drainage pipe with the perforations facing down.
- A filter fabric sock for the drainage pipe may be used instead of wrapping the pipe and gravel in filter fabric.

Confirmation

- The builder will illustrate compliance of criteria through photo documentation submitted to the EarthCraft Technical Advisor prior to the mid-construction project review.
- The EarthCraft Technical Advisor will review photo documentation provided by the builder or visually confirm for compliance of criteria.

DU 5: Damp proof below-grade walls

Purpose

Damp proofing prevents moisture and water passing through walls to interior spaces, preventing timber decay and structural damage.

Criteria

Apply damp proofing for all below-grade walls. Damp proofing materials are typically roller- or spray-applied asphalt coatings and/or bituminous felt.

Clarifications

- Wood-framed below-grade walls are not permitted along the exterior of the home.
- Do not install Class 1 vapor retarders on the interior side of air permeable insulation in exterior below-grade walls, except for tile at showers and tub walls.

Confirmation

- The builder will illustrate compliance of criteria through photo documentation submitted to the EarthCraft Technical Advisor prior to the mid-construction project review.
- The EarthCraft Technical Advisor will review photo documentation provided by the builder or visually confirm for compliance of criteria.

Examples

Correct



Damp proofing of below grade wall with a bituminous felt material.

DU 6: Install drainage plane per manufacturer's specifications (both, details below):

- Single lapped housewrap or taped, vapor permeable water-resistant barrier integrated with sheathing AND/OR
- Double layer of either building paper or housewrap behind cementitious stucco, stone veneer or synthetic stone veneer on framed walls

Purpose

A majority of all exterior wall claddings will allow water to pass through them. Therefore, a drainage plane is required to keep rainwater from entering the wall cavity and allow the water to drain down the wall. Drainage planes provide this rainwater control, but must be installed and sealed as instructed by the manufacturer on the entire building assembly exposed to the exterior to be effective.

Criteria

See above language and reference manufacturer's instructions for installation.

Clarifications

- A drainage plane must be installed and sealed as instructed by the manufacturer on the entire building assembly exposed to the exterior.
- Brick veneer requires a single layer of housewrap or taped, vapor permeable water-resistant barrier integrated with sheathing.
- The International Residential Code requires that "exterior plaster" (stucco) be installed over "a water-resistive vapor-permeable barrier with a performance at least equivalent to two layers of Grade D paper." All unvented, exterior cladding in contact with the substrate must meet the criteria.
- A single layer of building paper coupled with a single layer of housewrap meets the intent of the criteria.
- For stucco cladding systems, include weep screed per manufacturer's specifications.

Confirmation

- The builder will illustrate compliance of criteria through photo documentation submitted to the EarthCraft Technical Advisor for the mid-construction review.
- The EarthCraft Technical Advisor will review photo documentation provided by the builder or visually confirm for compliance of criteria.

Examples

Correct



Correct

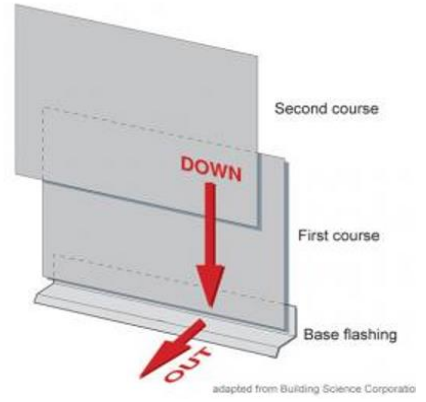

DU 7: Flashing complies with 2012 IRC and/or manufacturer specifications

All of the following must be met:

- All exterior penetrations flashed and sealed to the weather barrier prior to cladding
- Window and door pan flashing installed per manufacturer specifications
- Window and door side and head flashing installed per manufacturer specifications
- Step and kick-out flashing at wall/roof intersections
- Step flashing to 4" on wall surface and integrated with wall and roof drainage plane

Purpose

Windows and doors are an interruption in the wall's house wrap and therefore a vulnerable spot for water leakage. Properly installed flashing that is integrated with the other elements of the wall can help prevent water damage by directing water out rather than into the wall cavity.

Criteria

See above language and reference manufacturer's instructions for installation.

Clarifications

- For metal and rubber membrane roofs, install continuous flashing in place of step flashing.
- For porches, install L-shaped flashing to the top of the ledger board and integrate with drainage plane (vertical leg of the flashing must extend along the wall above the ledger and the horizontal leg extends over the top of the ledger).

Confirmation

The EarthCraft Technical Advisor will confirm installation of flashing during mid-construction review. Confirmation may occur during a field inspection or by a review of photo documentation provided by the builder.

Example

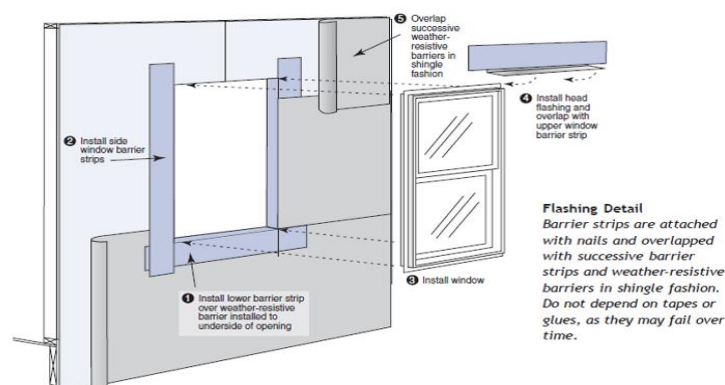

DU 8: Install siding per manufacturer and industry recommendations (details below):

- Maintain 2" clearance between wall siding and roof surface for wood siding, manufacturers' recommendation for composite products

Purpose

Correctly installed siding reduces risk of improper water drainage or intrusion of water between siding and sheathing, which could result in structural damage.

Criteria

Terminate wall siding a minimum of a 2" above roof surface unless otherwise directed by product manufacturer installation specifications.

Verification

The EarthCraft Technical Advisor will visually confirm compliance of criteria during mid-construction inspection.

Example

Correct



Flashing installed properly between roof and exterior wall.

DU 9: Rigid, moisture-resistant backing material behind tubs and showers

Purpose

Moisture-resistant protection is needed behind showers and tubs to prevent moisture from seeping into the wall structure.

Criteria

Install cement board, fiberglass enhanced sheathing or equivalent moisture-resistant backing material directly behind tub and shower tile and panel assemblies with caulked joints. Install moisture-resistant backing material in accordance with manufacturer specifications.

Clarifications

Do not use paper-faced board as a backing material for tile. Moisture-resistant gypsum board may be used behind tile-backing material, e.g., green board.

Verification

The EarthCraft Technical Advisor will visually confirm compliance of criteria during the mid-construction inspection.

Example

Correct



Install a moisture resistant backing material behind all bathtubs and showers

DU 10: Wall cavity insulation without a vapor retarder or kraft paper

Purpose

Installing a vapor retarder over vapor-permeable insulation on the interior of a wall does not ensure that moisture vapor in walls will be adequately controlled, regardless of which direction the paper is installed to face. Faced batts have the additional drawback of being difficult to install to RESNET Grade I or II quality and difficult to inspect for proper installation around framing, plumbing, and electrical components.

Criteria

Install 100% of wall cavity batt insulation without a vapor retarder or kraft paper.

Clarifications

Blown applications of fiberglass/cellulose material that requires netting is allowed provided the netting material is ≥ 1.0 perm.

Verification

The EarthCraft Technical Advisor will visually confirm compliance of criteria during the mid-construction inspection.

Example

Correct



Unfaced fiberglass batts allow for more effective installation around framing, electrical and plumbing components

High Performance Building Envelope (BE)

Buildings account for about 40% of all energy use in the United States. EarthCraft encourages an energy efficient building envelope to reduce this impact. One of the key elements to any energy efficient home is constructing a proper building envelope by sealing for air leaks, properly installing insulation and using high-quality windows. The building envelope is the barrier that separates the home's conditioned space from unconditioned space or the outside. The building envelope consists of two parts – an air barrier and a thermal barrier (insulation) that must be both continuous and contiguous (touching each other). In a typical residence, the building envelope consists of the roof or ceiling, walls, windows, doors, and floor or foundation.

BE 1: Envelope leakage testing: ≤ 5 Air Changes per Hour at 50 pascals (ACH50) or an Envelope Leakage Ratio (ELR) of ≤ 0.30

Purpose

Envelope leakage is a measure of the air tightness quality of the building envelope, an assessment of how much natural ventilation is supplied by air leakage and results may be used to assess energy losses resulting from uncontrolled air leakage. Envelope leakage allows air to enter the home from unknown sources that may contain air contaminants (e.g., moisture, pests, soil gases, dust and other particles). It is preferred to build a tight home and bring in fresh air from known sources via mechanical ventilation.

Criteria

Envelope leakage testing results must be less than or equal to 5 ACH50 or 0.30 ELR

Definitions

- CFM50: The volume of air in cubic feet per minute moved through the fan to maintain a 50 Pa pressure difference between the house and outside.
- ACH50 = ACH50 is the number of times the air volume in a building changes per hour at 50 pascals of pressure.
 - $ACH50 = (CFM50 * 60) / \text{conditioned volume}$
- Envelope Leakage Ratio (ELR): The quotient of the CFM50 measurement divided by the square footage of the building envelope, or SFBE.
 - Square footage of the building envelope (SFBE): Sum of the foundation/floor, exterior walls, ceiling areas
 - $ELR = CFM50 / SFBE$

Clarification

Floor area and volume must be calculated using RESNET standards for conditioned floor area and conditioned volume.

Verification

The EarthCraft Technical Advisor will diagnostically test compliance of criteria at the final inspection.

BE 2: Air seal where required by EarthCraft

All are required, as applicable to design:

- All gaps in exterior sheathing $\geq 1/4"$, including rim and band areas
- Cantilevered floors blocked at exterior wall
- All chases blocked and sealed: Fireplace, tubs, under stairs
- All plumbing and electrical penetrations
- Sill and sole plates sealed to subfloor and foundation
- All penetrations through subfloor/slab, framing and drywall
- Rough openings around exterior doors and windows
- HVAC Boots and mechanical ventilation fan penetrations through drywall and subfloor

Purpose

Air sealing is the process of reducing air infiltration and exfiltration of a home. Air leaks are a major cause of discomfort, moisture problems, energy losses and poor indoor air quality.

Criteria

Gaps and holes should be sealed using the appropriate sealing material, e.g., caulk (fire-rated, silicon, etc.), spray foam, foam inserts. If gaps/holes are too large to seal with caulk or spray foam alone, a rigid backing material (e.g., wood, drywall) should be used to cover the hole, with the edges of the backing material sealed with an appropriate air sealing material.

When sealing window/door rough openings with a spray foam product, selection of a low-expanding spray foam approved for use around windows and doors is preferred.

Verification

The EarthCraft Technical Advisor will visually confirm compliance of criteria during the mid-construction and final inspections.

Examples

Correct



Air seal all penetrations through the exterior wall (including band area in multi-story buildings) and in top plates and bottom plates

Examples continued on following page

BE 2: Air seal where required by EarthCraft (continued)

Correct



Air seal wall framing to subfloor and foundation wall

Correct

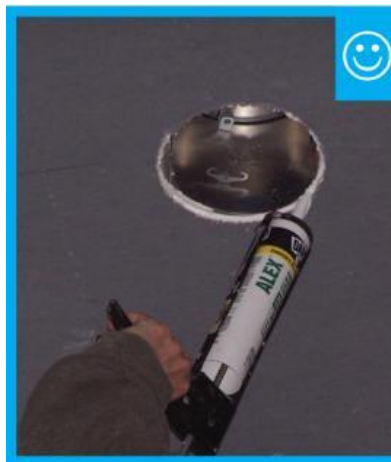

Caulk around all penetrations in drywall at attic, including lighting and ductwork

BE 3: All recessed can lights must be airtight, gasketed, and Insulation Contact (IC) rated in insulated ceilings

Purpose

If recessed lighting is installed incorrectly they may contribute significantly to air leakage and compromise building integrity. If a light fixture will be in contact with insulation, the fixture must be IC-rated to prevent any the possibility of flame ignition.

Criteria

See above language and reference manufacturer's instructions for installation.

Confirmation

The EarthCraft Technical Advisor will visually confirm compliance of criteria during the mid-construction inspection.

Example

Correct



Can lights shall be sealed, insulation contact (IC)-rated

BE 4: Insulated corners at all exterior locations

Purpose

Insulated corners reduce thermal bridging by allowing more space for insulation.

Criteria

Insulate the intersecting corner of two exterior walls to $\geq R-6$. EarthCraft will accept two-stud ("California corner") and two-stud corners with an offset stud to meet the intent of this criteria.

Clarifications

- Load-bearing corners in multi-story buildings or where porches/porch roofs are designed may request a waiver for this requirement
- The corner must be fully insulated to achieve the intent of this criteria; therefore corners with more than three studs are not permitted.

Confirmation

The EarthCraft Technical Advisor will visually confirm compliance of criteria at mid-construction inspection.

Examples

Correct



Incorrect

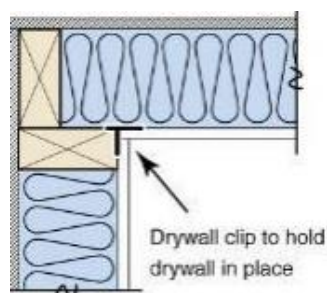

Non-load bearing exterior corners framed with more than three studs are not permitted

BE 5: Ladder T-walls at all exterior locations

Purpose

This method reduces the amount of framing members at the exterior wall and allows space for insulation, therefore reducing framing costs and thermal bridging.

Criteria

At interior-exterior wall intersections, the exterior wall should feature a ladder t-wall. Insulation should be installed at the exterior ladder t-wall to fill the cavity to full R-value.

Clarifications

- Consult local building codes in areas susceptible to high wind or seismic regions.
- If installing a ladder T-wall, begin first ladder 2' above the subfloor to aid in the installation of drywall.

Confirmation

The EarthCraft Technical Advisor will visually confirm compliance of criteria during the mid-construction inspection.

Examples

Correct



Install ladder t-walls where interior and exterior walls intersect to allow for maximum insulation coverage

Incorrect



Improper framing of intersection of exterior and interior wall. This method does not allow for insulating behind framing.

BE 6: Insulate building components to meet EarthCraft requirements

- Insulation R-value requirements are based on Climate Zone project is located in:

Climate Zone	Ceiling-Flat	Ceiling-Sloped	Wood Framed Wall	Attic Kneewall	Mass Wall	Basement Wall	Crawlspace Wall	Framed Floor	Slab	Cantilevered Floor
2	49	38	15	18	4/6	NA	NA	13	10	30
3	49	38	15	18	8/13	5/13	5/13	19	10	30
4	49	38	15	18	8/13	10/13	10/13	19	10	30

* A minimum of R-20, spray applied insulation is acceptable

Purpose

Insulating homes to EarthCraft standards will ensure that each home features a well performing thermal envelope.

Criteria

See above language for minimum cavity and continuous insulation values

Clarifications

- Attic kneewalls require minimum R-18 plus sealed attic-side air barrier (e.g., R-13 +R-5 rigid insulation, R-15 + R-3 rigid insulation, R-19 batt in 2x6 cavity with air barrier material).
- Roofline insulation may not be used in a vented attic.
- Framed floors over basement/crawlspace only require insulation if basement/crawlspace is outside of building envelope.
- If insulating a steel joist floor, R-6 continuous insulation must be installed in addition to floor insulation listed above.
- If insulating a steel studded wall or steel header, R-5 continuous insulation must be installed in addition to wall insulation listed above.
- Garage walls are considered exterior walls.
- Foundation walls require insulation if inside building thermal envelope.
- Slabs greater than 12" below grade as measured from the top of the slab are not required to have insulation.
- Permanently install insulation to crawlspace walls and extend downward from the termite inspection strip to within 9" of the finished interior grade adjacent to the foundation wall.
- Provide a 3" inspection strip immediately below the floor joists to allow inspection for termites. (The inspection strip may be insulated with a removable section of insulation, but is not required to be insulated.)
- Paper-faced batts may not be used (see DU 10)

Verification

The EarthCraft Technical Advisor will visually confirm compliance of criteria during mid-construction and final inspections.

BE 7: RESNET Grade II insulation or better installation quality (floors, walls, and ceilings)

Purpose

The efficiency of a building's thermal envelope is highly dependent on the quality of the installation of the insulation. A low quality insulation installation can lead to a degradation of the assembly R-value, leading to hidden costs for homeowners through excessive heat gains and losses.

Criteria

Install all insulation per manufacturer's recommendations to achieve a minimum quality Grade II or better as specified by criteria set forth by RESNET. Ensure that all insulation is in substantial contact with the building's air barrier and that batt insulation, if used, is cut to fit around electrical wiring/receptacles and plumbing.

Confirmation

The EarthCraft Technical Advisor will visually confirm compliance of criteria at mid-construction and final inspections.

Examples

Correct



Incorrect



BE 8: Unconditioned attics (All are required, as applicable to project design):

- Insulation baffles at all soffit vents, trays and attic access
- Loose-fill insulation R-value certificate, and depth rulers installed 1 per 300 ft²
- Platforms allow for full-depth insulation below
- Attic access within conditioned space $\geq R-49$
- Kneewalls $\geq 1\text{ft}$ tall insulated to R-18 with sealed attic side air barrier
- Kneewalls $< 1\text{ft}$ tall fully covered to achieve same R-value as surrounding attic

Purpose

It is important to Insulate unconditioned attic spaces correctly because they are a potential source of significant heat loss and gain. This item focuses on installing attic insulation to the correct depth (R-value) at differing attic locations and ensuring the insulation is not susceptible to wind-washing or convective losses.

Criteria

See above requirements for reference.

Confirmation

The Technical Advisor will visually verify compliance during the mid-construction and final inspections.

Examples

Correct



Correct

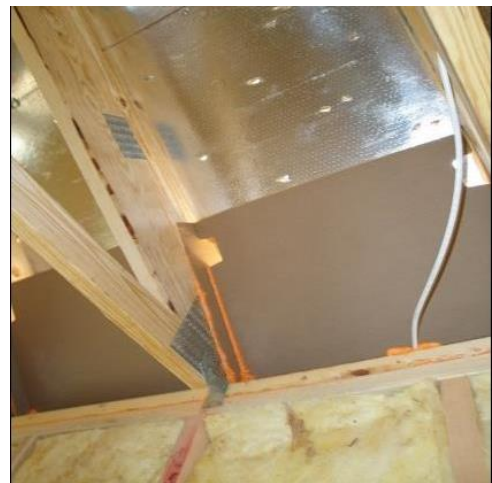

BE 9: Window and skylight U-factor and Solar Heat Gain Coefficient (SHGC) meets IECC 2012

Requirements are based on Climate Zone of project location:

Climate Zone	Window U-factor	Skylight U-factor	Glazed Window SHGC
2	0.32	0.75	0.27
3	0.32	0.65	0.27
4	0.32	0.60	0.27

Purpose

The U-Factor determines how well your windows insulate your home and the Solar Heat Gain Coefficient (SHGC) is a measure of how much solar-radiated heat energy can transfer through a window. To maximize energy efficiency, window and skylights must be carefully selected to comply with the IECC U-factor and SHGC specifications.

Criteria

See above language and reference the IECC 2012 for further specification details.

Clarifications

- Up to 15 square feet of glazing or decorative glass may be exempt from this requirement.

Confirmation

- The builder must present documentation demonstrating compliance of criteria to the EarthCraft Technical Advisor prior to the mid-construction inspection.
- The EarthCraft Technical Advisor will review documentation provided by the builder for compliance of criteria and verify installation during the mid-construction inspection.

PERF 1: Confirmed HERS Index \leq 55

Purpose

Home energy modeling provides many benefits to the builder and homeowner. For example, energy models provide annual energy usage estimates, assigns the home a HERS Index Score that can be compared with other homes and can determine the home's compliance with a host of programs, standards and codes. Home energy modeling also allows the builder and homeowner to pick and choose which appliances, lighting, HVAC equipment, insulation values, etc. to install in the home instead of following a prescriptive building envelope and HVAC systems list. Energy modeling affords this flexibility while ensuring the home meets the Performance Badge's energy efficiency goal of a HERS Index \leq 55.

Criteria

Home energy model based on actual construction must demonstrate a confirmed HERS Rating Index that is equal to or less than 55

Clarifications

- The builder must present documentation demonstrating compliance of criteria to the EarthCraft Technical Advisor at mid-construction.
- The EarthCraft Technical Advisor will develop an energy model in accordance with RESNET modeling criteria and confirm compliance of criteria at mid-construction and final inspections.
- If a project chooses to pursue the Performance Badge the building insulation, mechanical equipment, envelope infiltration, and duct leakage requirements will be as follows:
 - Minimum insulation and window values must be equal to or more efficient than local code requirements
 - Building heating and cooling equipment must meet minimum efficiency requirements set by local code. If a gas system is installed it must be sealed combustion.
 - Domestic water heating equipment must meet minimum efficiency requirement set by local code. If a gas system is installed it must be direct vent.
 - Building infiltration must be equal to or tighter than local code requirement
 - HVAC duct leakage testing results must be equal to or tighter than local code requirements

Energy Efficient HVAC Systems (ES)

Buildings account for about 40% of all energy use in the United States. Constructing an energy-efficient home provides variety of benefits to both a home's occupants and to the environment. Once the building envelope has been designed, evaluating heating and cooling systems, ventilation, and domestic water heating using the house-as-a-system approach are critical to achieving a high performance home.

An energy efficient home not only provides savings on utility bills to residents but also improves their comfort and health. Comfort is a function of air temperature, relative humidity and radiant heating and cooling, all of which are impacted by the energy systems used in a home. In addition, using less energy reduces the need to extract natural resources, reduces air pollution and eases the strain on our water resources. EarthCraft encourages the use of energy efficient HVAC systems to reduce this impact.

ES 1: Size and select all HVAC equipment in accordance with ACCA Manuals J and S

Purpose

Properly sizing and selecting HVAC equipment account for heat loss/gain throughout the year based on factors such as a building's geographic location, orientation of windows and doors, envelope tightness, outdoor air ventilation, duct leakage, and insulation levels allow an HVAC contractor to provide a system that can properly meet design and efficiency goals.

Criteria

Size and select all HVAC equipment in accordance with the Air Conditioning Contractors of America (ACCA) Manuals J and S. Load calculation must coordinate with accurate construction specifications and plans for the project as well as as-built conditions.

Complete load calculation with accredited ACCA Manual J 8th Edition Full Residential Load Calculation software. [Reference ACCA for a list of approved software.](#)

OR

Load calculation must be stamped by a Professional Engineer along with a signed "Professional Engineer Load Calculation Affidavit".

The following criteria should be met for all equipment sizing:

- Load calculation must be based on actual home orientation as constructed
- Use most current ASHRAE Handbook of Fundamentals Climate Design Information for outdoor design temperatures
- Design heating and cooling systems using the annual outdoor design conditions as defined in the most current ASHRAE Handbook of Fundamentals
- The 99% design conditions must be used to size heating equipment
- The 1% design conditions must be used to size cooling equipment
- Perform room by room load calculations
- Base infiltration on semi-tight (average) or tighter
- Base duct tightness on notably sealed or tighter
- Include ventilation based on designed values
- Equipment sizing falls within the Manual S oversizing limits

Clarifications

The abridged edition of ACCA Manual J is not an acceptable methodology within the EarthCraft program.

Multispeed or multistage equipment may have OEM nominal size increments of one ton. Therefore, the use of multispeed or multistage equipment can provide extra flexibility to meet the equipment sizing requirements. The equipment oversizing limit shall be based on the largest capacity of the unit.

Floor area must be calculated using RESNET standards for conditioned floor area

Example #1

Equipment sizing selection:

If the load calculation specifies a total sensible load of 36,000 Btuh, the 115% oversizing limit allows for using up to 41,400 Btuh:

$$36,000 \times 1.15 = 41,400 \text{ Btuh}$$

If Manufacturer X makes a nominal 3 ton AC unit and a nominal 4 ton AC unit, but no sizes in between, then Builder Y may install the 4 ton unit made by Manufacturer X as long the nominal 3 ton unit has insufficient capacity (i.e. total capacity of $36,000 \times 0.95 = 34,200$ Btuh).

Alternately, if Builder Y wanted to use a heat pump from Manufacturer Z and Manufacturer Z offers nominal 3 ton (33,000 Btuh), 3.5 ton (39,400 Btuh) and 4 ton heat pump (45,800 Btuh), then Builder Y must install the nominal 3.5 ton unit by Manufacturer Z because the unit is between the Manual J specification and the climate zone 3, 115% oversizing limit set Manual S.

Additional Resources

- Air Conditioning Contractors of America, see [here](#).

Confirmation

The EarthCraft Builder shall notify their HVAC contractor of the requirements for meeting Manual J and S requirements. The Technical Advisor will review the load calculations for accuracy and completeness at mid-construction review.

ES 2: Heating equipment efficiency (Details below):

- Ducted furnace(s) and/or boiler(s) >90% AFUE, sealed combustion
- Ducted heat pump(s) >8.2 HSPF and within 0.5 ton of load calculation, Climate Zone 4 >8.5 HSPF and within 0.5 ton load calculation

Purpose

Furnaces with a rated Annual Fuel Utilization Efficiency (AFUE) of $\geq 90\%$ are equipped with a sealed combustion chamber that prevents provides combustion air from a known location. Sealed combustion chambers have the added safety benefit of being sealed from external conditions, thus reducing the risk of flame roll out and backdrafting of combustion products.

A properly sized heating system is designed to adequately condition a space according to the summer and winter loads placed on it. Using oversized equipment results in higher purchase prices and increased day-to-day charges for use.

Criteria

Furnace(s) $\geq 90\%$ AFUE and within 40% of load calculation

- All heating equipment must be $\geq 90\%$ AFUE for gas combustion furnaces. All furnaces must be sized within 40% of the heating load as determined by the load calculation. If the required fan speed cannot be provided by a smaller unit, a furnace may be more than 40% oversized.

Heat pump(s) Climate Zone 2/3 ≥ 8.2 HSPF and within 0.5 ton of load calculation, Climate Zone 4 ≥ 8.5 and within 25% of load calculation

- All heating equipment must be rated at ≥ 8.2 Heating Seasonal Performance Factor (HSPF) for heat pumps in Climate Zones 2 and 3 or ≥ 8.5 HSPF in Climate Zone 4.
- Heat pumps in Climate Zones 2 and 3 must be within 0.5 ton of the load calculation or the next available size. Heat pumps in Climate Zone 4 must be within 0.5 of the load calculation or the next available size.

Confirmation

- The builder must present documentation demonstrating compliance of criteria to the EarthCraft Technical Advisor at the mid-construction inspection
- The EarthCraft Technical Advisor will review documentation provided by the builder for compliance of criteria and will visually confirm compliance of criteria at final inspection.

ES 3: Cooling equipment efficiency (Details below):

- Ducted split system ≥ 14.5 SEER
- Ducted package unit ≥ 12 EER
- Ducted ground-source heat pump(s): ≥ 15 EER

Purpose

A high-efficiency system will deliver more comfort, better moisture control, improved air quality, and quiet operation, while using less energy than a less efficient system.

Criteria

If installing a split system HVAC unit(s), the cooling equipment must have a seasonal energy efficiency ratio (SEER) of 14.5 or greater. If installing a packaged HVAC unit(s), the cooling equipment must have an energy efficiency ratio (EER) of 12 or greater. If installing a groundsource heat pump(s), the energy efficiency ratio (EER) must be 15 or greater.

SEER and EER must be determined by the Air Conditioning, Heating and Refrigeration Institute (AHRI).

Additional Resources

A list of qualified products can be found [here](#).

Confirmation

- The builder must submit documentation demonstrating compliance of criteria to the EarthCraft Technical Advisor at the mid-construction review.
- The EarthCraft Technical Advisor will review documentation provided by the builder for compliance of criteria and will visually confirm compliance of criteria at mid-construction and final inspections.

ES 4: Programmable thermostat with adaptive recovery capability

Purpose

Programmable thermostats can be used to suit the needs of the occupants in the cooling or heating seasons during periods when a building is occupied and when it is not. Proper use of programmable thermostats can assist occupants with reducing energy consumption by allowing them to program a schedule that reduces runtime.

Criteria

All heating and cooling equipment must have a programmable indoor thermostat or thermostat installed according to the manufacturer's specifications. Building occupants should be provided the user manual as education for proper use and maintenance of thermostats. Heat pumps must have a programmable thermostat installed that includes adaptive recovery capability.

Confirmation

The EarthCraft Technical Advisor will visually confirm compliance of criteria at final inspection.

ES 5: No HVAC equipment or ductwork located in garage, and no conditioned air supplied to garage

Purpose

Garages, including attached and carports, are known sources of indoor air contaminants and must be fully separated from conditioned space. To ensure that HVAC systems for the living space, including equipment and ductwork, are fully separated from garages they cannot be installed these spaces and cannot provide conditioned air to them.

Criteria

Do not located HVAC equipment or ductwork inside garage spaces. Do not design distribution equipment to supply conditioned air to garage spaces.

Clarification

HVAC equipment and ductwork are considered separate from garage spaces if they are separated from the garage by $\geq 1/4$ " drywall that has been air sealed at all penetrations and connections. If equipment and/or ductwork is located in a closet that is accessible from the garage, the closet must be air sealed to separate the closet from the garage and the door should be gasketed on all sides.

Confirmation

Technical Advisor will visually confirm that HVAC equipment and ductwork is separated from garage spaces during mid-construction inspection(s). If necessary, Technical Advisor shall complete verification that the entire system is separated at the final inspection.

Examples

Incorrect



Do not install HVAC equipment or ductwork that serves the living space within garage.

ES 6: If designed, HVAC ductwork meets EarthCraft requirements for installation, insulation and air sealing (details below):

- Air seal ductwork using mastic/mastic tape:
 - Plenum seals
 - Collars to plenum
 - Collars and boots to flex liner
 - Seams in boots and wyes
 - All flex liner to wye connections
 - Air handler unit seams
- Insulate ductwork to standards set by EarthCraft:
 - Unconditioned attic: R-8
 - All other spaces: R-6
- HVAC ductwork installation meets EarthCraft standards (Details below):
 - Fully duct all supply and return ducts
 - No ducts in exterior walls or vaulted ceilings
 - Install rigid ducts, or pull all flex ducts with no pinches and support at intervals $\leq 5'$
 - Ducts suspended above attic floor trusses to allow for full depth of attic floor insulation
- HVAC system and ductwork is protected during construction (Details below):
 - Protect all ceiling/floor registers until construction is complete
 - Protect HVAC fan until construction is completed
 - Pleated filter installed during construction

Purpose

Poorly sealed ductwork allows conditioned air to leak both inside and outside the building envelope, reducing system efficiency. Ductwork insulation controls heat transfer and reduces the risk of condensation on ductwork by reducing the temperature difference between air within the ductwork and air surrounding the exterior.

By keeping construction dust and debris out of ductwork and the HVAC equipment throughout the duration of construction IAQ goals and system integrity are maintained.

Criteria

Seal all seams, joints and connections in forced-air delivery systems using mastic paste or Butyl rubber backed foil tape (mastic tape), including but not limited to:

- Supply and return ducts
- Supply and return plenums
- Duct-to-plenum connection
- Y-splits, butt joints and boot connections
- Outdoor air intakes
- Air handler condensate and refrigerant line penetration, wire penetrations and unused holes in the air handler cabinet

Clarifications

- Duct tape is not a suitable sealant for ducts. Foil tape may only be used for sealing leaks at the air handler's removable access panels and at filter access panels. Duct boots may be sealed to floor, wall, or ceiling using caulk, foam, mastic tape, or mastic paste.
- Wrap mastic tape at least two times around duct seam touching at least 1 1/2" of duct inner liner and metal collar or sleeve.
- Assemble duct board using code-approved foil tape and coat seams with layer of mastic paste covering seams by 1.5" on both sides and as thick as a nickel.
- Ducts left completely exposed inside conditioned space (e.g. modern loft-style duct systems) are not required to be insulated but must be 90% visible at final inspection.

Confirmation

- The EarthCraft Technical Advisor will visually confirm compliance of criteria at mid-construction and final inspections.

* Examples of proper ductwork sealing on following page

* Example of proper and improper ductwork installation on following pages

Examples of proper ductwork sealing:

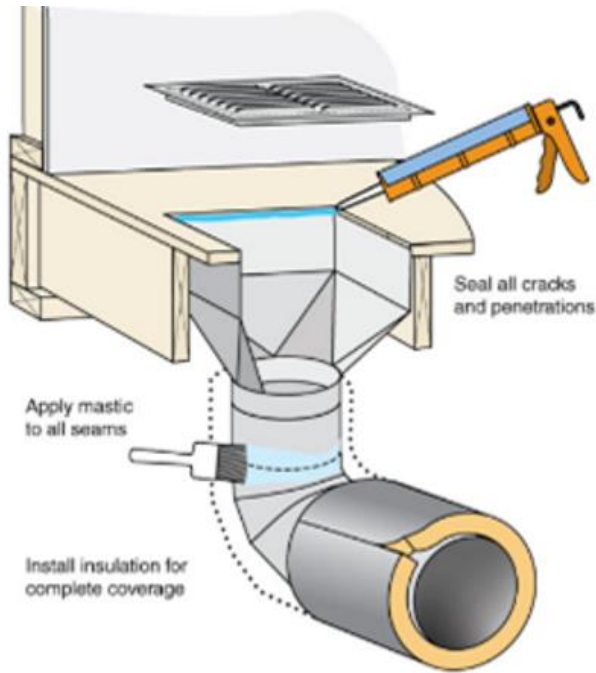

Air seal all seams in ductwork, including ductwork seams, duct-to-boot connections, and gaps where duct boots connect to the subfloor/drywall. Appropriate air sealing materials for ductwork are mastic/mastic tape. Appropriate materials for air sealing boots to subfloor/drywall include mastic, caulk, and/or foam

Air seal all gaps and seams at HVAC equipment, including manufactured seams, penetrations for wires and refrigerant lines, and duct plenums. Appropriate air sealing materials are mastic/mastic tape.

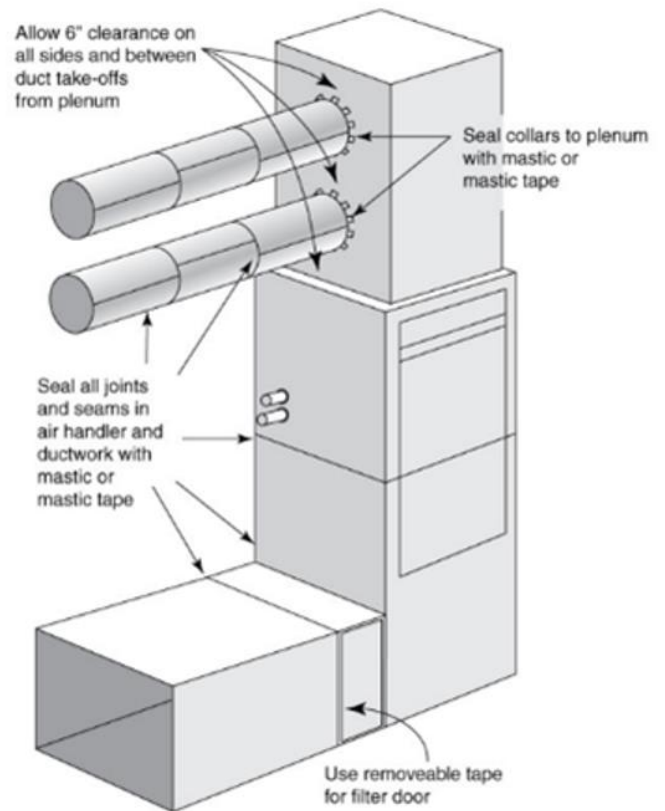

Example of proper and improper ductwork installation:

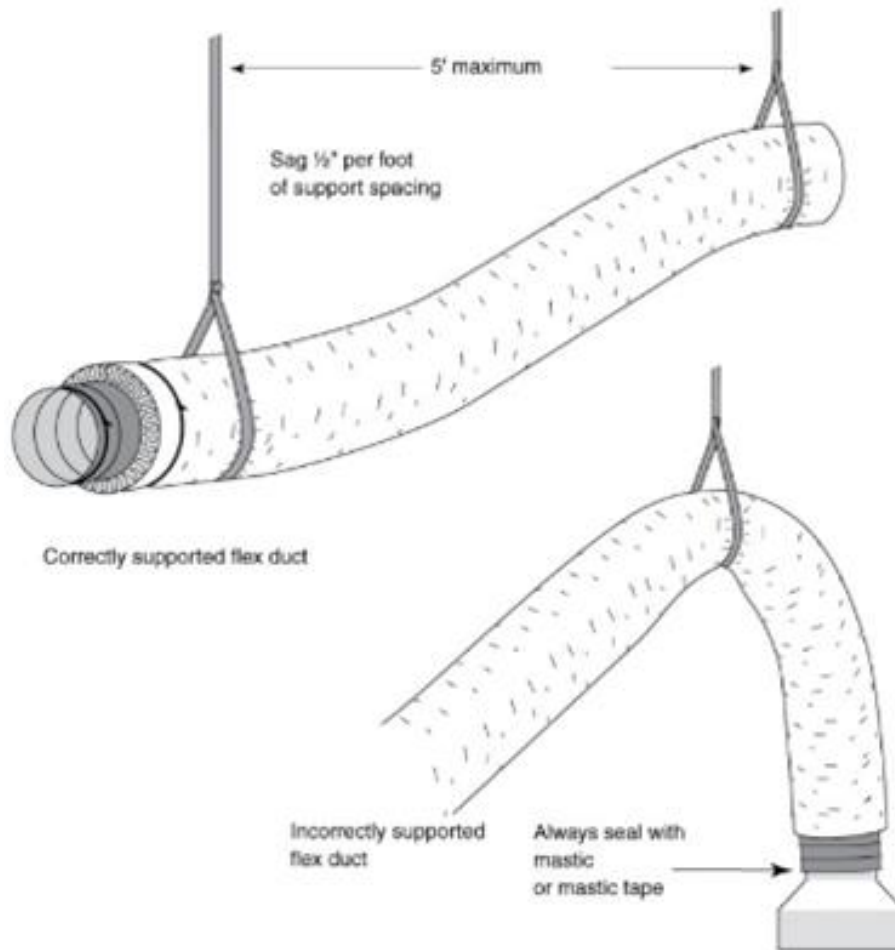

Properly support all flexible ductwork with ≥ 1 " strapping at lengths $\leq 5'$.

ES 7: Filters (Details below):

- Filter easily accessible for occupant
- Access panel includes gasket and fits snugly
- At final, all filters \geq MERV 6

Purpose

Filters should be easily accessible so that occupants may change them when needed, this increases the likelihood for good indoor air quality. A snug-fitting gasket door prevents air leakage during system operation.

Higher rated air filters are more efficient at trapping particulate matter from indoor air. HVAC filters should have a Minimum Efficiency Reporting Value (MERV) of ≥ 6 to meet EarthCraft requirements.

Criteria

Filter easily accessible for occupant

- Design system so that the filter is easily accessed by occupants. Easily accessed includes locating the filter in a location that is reasonable for an individual to reach and is not obstructed in any way that would prevent an individual from fully pulling out a filter to remove it.

Access panel includes gasket and fits snugly

- Eliminate filter bypass between the filter and filter rack by sealing the filter access panel to prevent air leakage and ensuring it fits snugly against the exposed edge of the installed filter when closed.

At final, all filters are \geq MERV 6

- Install an HVAC filter with \geq MERV 6 (according to ASHRAE 52.2) on all HVAC systems. HVAC design and installation must account for airflow based on filter selection.

Clarifications

- Filters perform best when the filter rack design includes flexible, air tight (e.g., closed-cell foam) gasket material on the downstream side of the filter and friction fit or spring clips installed on the upstream side of the filter.
- Non-standard efficiency ratings for filters (e.g., 3M's Microparticle Performance Rating (MPR)) and filters that do not have a MERV rating (e.g., electrostatic filters) need prior approval by EarthCraft.
- HVAC system design and installation must be designed to accommodate the criteria.

Confirmation

The EarthCraft Technical Advisor will visually confirm compliance of criteria at mid-construction and final inspections.

ES 8: If applicable, test duct leakage based on floor area served (Details below):

- Leakage to outside $\leq 3\%$ Not required if ducts are located 100% in conditioned space
- Total leakage $\leq 6\%$ at final

Purpose

The duct leakage test is a diagnostic tool designed to measure the air tightness of heating and air conditioning duct systems and to identify air leakage locations. Tighter HVAC distribution systems more effectively deliver conditioned air throughout a home and ensure comfort goals are met.

Criteria

Leakage to outside $\leq 3\%$. Not required if ducts are located 100% in conditioned space.

- Duct leakage test result for leakage to outside shall be $\leq 3\%$ of floor area served. The leakage to outside test is not required if 100% of ductwork, including the mechanical equipment, is located within conditioned space.

Total leakage $\leq 6\%$ at final

- Duct leakage test result for total leakage shall be $\leq 6\%$ for all projects.
- If any portion of the distribution system, including the mechanical equipment, is located outside of conditioned space then the total leakage test shall be completed during the final inspection.

The calculation for determining percent duct leakage is:

$$\text{Percent (\%)} \text{ Duct Leakage} = (\text{CFM25} \div \text{floor area served (ft}^2\text{)} \times 100)$$

Where:

Percent Duct Leakage may be applied to Leakage to Outside and Total Leakage

CMF25 is the measured duct leakage at 25 pa pressure difference between the ductwork and exterior.

Floor area served is the area of conditioned space served by a single system.

Clarifications

- The leakage to outside and total leakage duct test applies to all ducted HVAC systems. HVAC systems designed and installed to operate without distribution systems (ductless systems) are exempt from this requirement.
- Floor area must be calculated using RESNET standards for conditioned floor area.

Confirmation

The EarthCraft Technical Advisor will diagnostically test compliance during mid-construction and/or final inspections, as applicable to project design.

CMFRT 1: If designed, improved duct design (Details below):

- Install ducts per ACCA Manual D duct design
- Measure and balance airflow per ACCA Manual B
- Verify supply and return duct static pressure

Purpose

Improved duct design ensures that HVAC performance and comfort goals are met for a project. A Manual D duct design allows the HVAC contractor to design the distribution system in a way that delivers adequate conditioned air to each room without over pressurizing or depressurizing other areas.

Criteria

Design and install HVAC ductwork in accordance with an ACCA Manual D. A list of approved Manual D software may be found [here](#).

Confirmation

- The EarthCraft Builder will provide the Technical Advisor with the balance and pressure test results prior to submitting project for certification.
- The Technical Advisor will review the Manual D duct design prior to the mid-construction inspection. During the mid-construction inspection, the TA will visually verify that the as-built duct design matches the Manual D design.

CMFRT 2: If ducts are in unconditioned attic, install ENERGY STAR roof

Purpose

An ENERGY STAR roof serves to cool down the attic interior, reducing the temperature inside the attic, which puts less strain on the duct system.

Criteria

If HVAC ductwork will be installed in an unconditioned attic, design and construct the building roof using ENERGY STAR certified roof products. Information on ENERGY STAR roof products can be found [here](#).

Clarification

If ducts are buried in the attic insulation, this is an acceptable alternative to installing an ENERGY STAR roof if the following criteria are met:

- Ducts are insulated to a minimum of R-8
- There is a minimum of R-19 below and above the duct, excluding the R-value of the duct insulation itself
- Total duct leakage is no more than 2% CFA

Confirmation

The Technical Advisor will visually verify compliance during the mid-construction inspection.

CMFRT 3: Verify proper refrigerant charge and total system airflow within 20% of design air flow

Purpose

Verifying correct refrigerant charge helps ensure that the equipment operates at maximum efficiency and decreases the likelihood of premature equipment failure.

Criteria

- Perform refrigerant charge test to ensure appropriate charge for HVAC equipment with subcooling deviation $\pm 3^{\circ}\text{F}$ or superheat deviation $\pm 5^{\circ}\text{F}$.
- Perform system airflow test using a flow hood, anemometer or other EarthCraft approved equivalent to ensure total system airflow is within 20% of the design airflow.

Clarifications

This requirement may be met by methods according to ACCA 5 QI-2007:

- Superheat method test measurement within 5% of the manufacturer-recommended charge
- Subcooling method test measurement within 3% of the manufacturer-recommended charge
- Other equivalent method/tolerance approved by the equipment manufacturer

Geothermal heat pumps, mini-split heat pumps and hermetically sealed factory-charged stems may not be appropriate for standard subcooling or superheat refrigerant charge testing. To accommodate these system types, an OEM (original equipment manufacturer) test procedure may be used and documented.

Confirmation

Refrigerant Charge

- The builder must submit documentation demonstrating compliance of criteria to the EarthCraft Technical Advisor prior to submitting the project for certification
- The EarthCraft Technical Advisor will review documentation provided by the builder for compliance of criteria.

Total System Airflow

- The EarthCraft Technical Advisor will diagnostically test compliance of criteria at the final inspection, or be present to observe the test being completed by the HVAC contractor and confirm test results comply with criteria.

CMFRT 4: Dual-stage compressor

Purpose

Dual-stage HVAC compressors offer increased efficiency over standard single-stage compressors. These compressors are able to vary their output to provide longer runtimes, which helps control indoor humidity levels and allows for increased filtration of indoor air.

Criteria

All cooling equipment must have a dual-stage (or two-stage) compressor for improved humidity removal and increased efficiency. The higher stage compressor must comply with the maximum oversizing criteria as required for all cooling equipment.

Clarifications

- When a dual-stage compressor is used for a heat pump to lower the balance point, size the air conditioner at design conditions for the lower fan speed only. The second stage shall not come on at design temperatures. Use the second stage to size the heat pump at design heating conditions.
- If a system is designed and installed with a variable speed compressor, this requirement will not apply to a project.

Confirmation

The EarthCraft Technical Advisor will visually confirm compliance of criteria at final inspection.

CMFRT 5: If ducted system installed, measure pressure differential ≤ 3 Pa

Purpose

Ensure that there will not be a significant pressure difference in separate rooms of the house. Pressure differentials can result in poor system airflow, which may cause damage to the HVAC system and impact indoor air quality by introducing contaminants for outside the building envelope.

Criteria

Design HVAC system to operate at balanced system pressures by providing multiple returns or by installing return air pathways for rooms that can be separated from the central return via door closures.

Confirmation

The EarthCraft Technical Advisor will visually confirm compliance of criteria at the mid-construction inspection and will diagnostically test compliance of criteria at the final inspection.

Examples

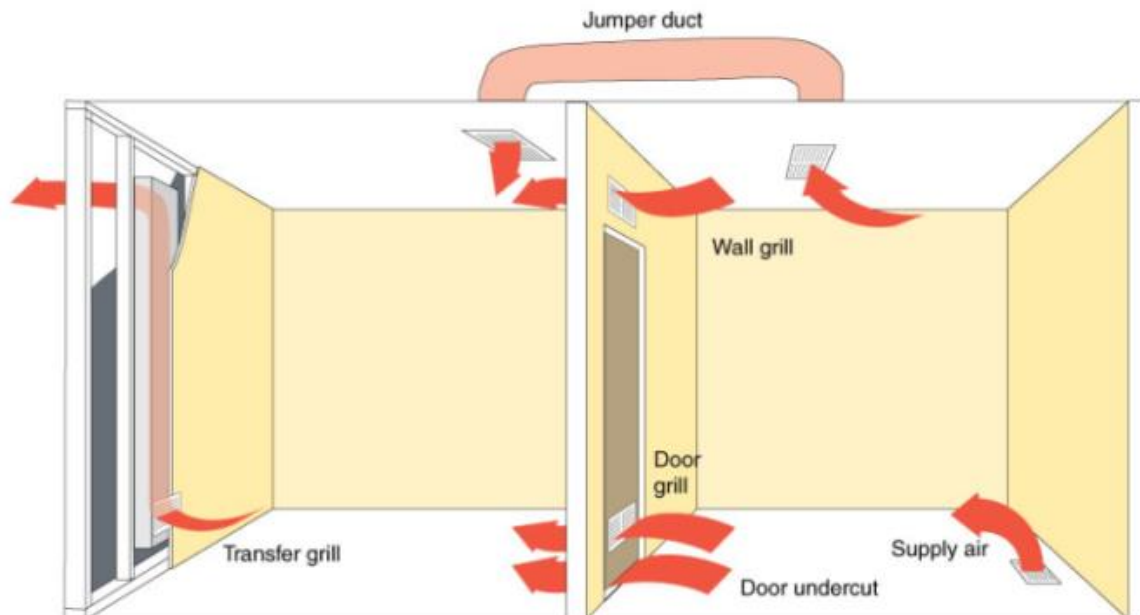

Indoor Air Quality (IAQ)

The average American spends over 90% of their time indoors, so creating a healthy and comfortable indoor environment is an important issue for any resident, especially those who are sensitive to poor air quality. In particular, children, seniors, and individuals with respiratory problems and compromised immune systems may suffer more from indoor air quality problems. EarthCraft Builders can improve the health of a home by installing materials with fewer pollutants, flushing any pollutants out through proper ventilation, and controlling moisture to eliminate mold growth.

The Indoor Air Quality section consists of items that aim to reduce the presence of pollutants and contaminant in the air inside a home. Reducing or eliminating the presence of manmade pollutants such as volatile organic compounds or natural occurring carcinogens such as radon leads to a healthier environment for occupants.

IAQ 1: Provide whole building and local exhaust ventilation based on ASHRAE 62.2-2016 Ventilation and Acceptable Indoor Air Quality in Residential Buildings:

- Include whole building ventilation sizing in Manual J calculations
- Install labeled, accessible whole building ventilation controls
- Verify whole building ventilation airflow cubic feet per minute (CFM)
- Select a whole building ventilation design (choose one):
 - Balanced system
 - Supply system with \geq MERV 4 filter prior to outdoor air entering living space or HVAC unit
 - If central fan integrated system is used, HVAC system must be equipped with variable speed motor and thermostat
 - Stand-alone exhaust system designed to operate continuously. All HVAC systems must be equipped with \geq MERV 13 filter.
- Vent all full bathrooms with ENERGY STAR \geq 50 CFM on-demand exhaust fan to exterior
 - Bath fans ducted using prescriptive design based on ASHRAE 62.2-2016 or measure airflow CFM at final
- Vent all kitchens with ENERGY STAR \geq 100 CFM on-demand range hood to exterior
 - Range fan ducted using prescriptive design based on ASHRAE 62.2-2016 or measure airflow CFM at final
 - If range hood capable of \geq 400 CFM, install make-up air to meet IRC 2012 requirements

Purpose

Whole-house ventilation introduces fresh air into living spaces to dilute pollutants that cannot be removed completely through spot ventilation and/or filtration, thus providing for a healthy indoor environment.

Criteria

Install a whole-building mechanical ventilation system and mechanical exhaust systems that are designed to meet the air flow requirements of ASHRAE 62.2-2016.

The whole building air flow may be calculated based on Section 4.1.1 Total Ventilation

Rate:
$$Q_{tot} = 0.03A_{floor} + 7.5(N_{br} + 1)$$

Where: **where**

Q_{tot} = total required ventilation rate, cfm

A_{floor} = dwelling-unit floor area, ft²

N_{br} = number of bedrooms (not to be less than 1)

OR Projects may use Table 4.1a to determine minimum CFM for whole building ventilation

TABLE 4.1a (I-P) Ventilation Air Requirements, cfm

Floor Area, ft ²	Bedrooms				
	1	2	3	4	5
<500	30	38	45	53	60
501–1000	45	53	60	68	75
1001–1500	60	68	75	83	90
1501–2000	75	83	90	98	105
2001–2500	90	98	105	113	120
2501–3000	105	113	120	128	135
3001–3500	120	128	135	143	150
3501–4000	135	143	150	158	165
4001–4500	150	158	165	173	180
4501–5000	165	173	180	188	195

Local exhaust system airflow CFM may be verified via a field measurement completed during the final inspection, or by designing and installing the distribution system based on the Prescriptive Duct Sizing Table:

TABLE 5.3 Prescriptive Duct Sizing

Duct Type	Flex Duct								Smooth Duct							
Fan Airflow Rating, cfm @ 0.25 in. of water (L/s @ 62.5 Pa)	50 (25)	80 (40)	100 (50)	125 (65)	150 (75)	200 (100)	250 (125)	300 (150)	50 (25)	80 (40)	100 (50)	125 (65)	150 (75)	200 (100)	250 (125)	300 (150)
Diameter ^a , in. (mm)	Maximum Length ^{b,c,d} , ft (m)															
3 (75)	×	×	×	×	×	×	×	×	5 (2)	×	×	×	×	×	×	×
4 (100)	56 (17)	4 (1)	×	×	×	×	×	×	114 (35)	31 (9)	10 (3)	×	×	×	×	×
5 (125)	NL	81 (25)	42 (9)	16 (5)	2 (0.6)	×	×	×	NL	152 (46)	91 (28)	51 (16)	28 (9)	4 (1)	×	×
6 (150)	NL	NL	158 (48)	91 (28)	55 (17)	18 (5)	1 (0.3)	×	NL	NL	NL	168 (51)	112 (34)	53 (16)	25 (8)	9 (3)
7 (175)	NL	NL	NL	NL	161 (49)	78 (24)	40 (12)	19 (6)	NL	NL	NL	NL	NL	148 (45)	88 (27)	54 (16)
8 (200) and above	NL	NL	NL	NL	NL	189 (58)	111 (34)	69 (21)	NL	NL	NL	NL	NL	NL	198 (60)	133 (41)

a. For noncircular ducts, calculate the diameter as four times the cross-sectional area divided by the perimeter.
 b. This table assumes no elbows. Deduct 15 ft (5 m) of allowable duct length for each elbow.
 c. NL = no limit on duct length of this size.
 d. × = not allowed; any length of duct of this size with assumed turns and fitting will exceed the rated pressure drop.

Confirmation

The HVAC Manual J Load Calculation shall include whole building ventilation CFM based on the calculations in ASHRAE 62.2-2016. The Technical Advisor will review the Manual J report to verify system has been designed for ventilation airflow. At final, Technical Advisor shall field verify that installed ventilation airflow CFM meets the minimum continuous airflow required.

Note:

- Projects may design whole building ventilation CFM using the infiltration credit in ASHRAE 62.2-2016. Technical Advisor shall review Manual J input for reasonableness, and at final shall field verify actual building envelope infiltration and ventilation airflow CFM. If necessary, whole building ventilation shall be field adjusted to comply with ASHRAE 62.2016.
- Projects using the Prescriptive Duct Sizing Table for local exhaust shall document compliance with photo documentation capturing ≥75% of the distribution system

IAQ 2: Carbon monoxide detector (one per sleeping area, hard wired with battery back-up)

Purpose

Carbon monoxide poisoning is a significant health threat to building occupants can result in long-term neurologic or cardiovascular complications if conditions are not remedied. Due to the possibility of combustion appliances being introduced into the home after construction, CO monitors should be installed even if the house has no attached garage, fireplace or combustion appliances installed within or adjacent to conditioned space.

Criteria

Install one carbon monoxide (CO) detector per floor. If bedrooms are on the floor, install the CO detector in a central location near all bedrooms. CO detectors shall be installed in accordance to manufacturer specifications. All CO detectors must be hard-wired with battery back-up. CO detectors must be certified by CSA 6.19-01 or UL 2034.

Clarification

Combination smoke/CO detectors meet the intent provided they are certified by CSA 6.19-01 or UL 2034.

Confirmation

At final, Technical Advisor shall field verify that combustion detectors have been installed that are certified by CSA 6.19-01 or UL 2034.

IAQ 3: No unvented combustion appliances, fireplaces or space heaters within or adjacent to the living space. Separate atmospherically vented and/or fan assisted vented appliances from conditioned space.

Purpose

Due to indoor air safety, health, and moisture concerns, it is recommended that unvented appliances never be installed within the conditioned space of homes. Additionally, atmospherically vented and/or fan-assisted draft systems should be installed separate from the conditioned space.

Unvented systems are identified as having no systems to vent combustion by-products to the exterior. Atmospherically vented and fan-assisted appliances rely on surrounding atmosphere to provide for ventilation of combustion by-products to the exterior. Each type of appliance has the risk of introducing harmful combustion gases, such as carbon monoxide, and moisture vapor back into the space in which they are located - greatly adding to indoor humidity levels and increasing the risk of unsafe indoor environmental conditions for building occupants.

Criteria

Unvented combustion appliances, fireplaces or space heaters should not be installed within or adjacent to the conditioned space of the home. Atmospherically vented and fan-assisted draft appliances should be installed separate from the conditioned space.

Clarifications

Vent all combustion fireplaces and appliances to remove combustion products as well as process fumes to the exterior of a building.

Atmospherically vented and fan-assisted draft appliances may be installed in unconditioned locations adjacent to conditioned space, however all walls, floors and ceilings separating the appliances from conditioned space shall be air sealed and insulated to meet the IECC 2015.

Confirmation

- The Technical Advisor will visually confirm compliance during the mid-construction review and final inspection.
- Technical Advisors shall field verify that atmospherically vented and/or fan assisted draft appliances have been separated from conditioned space via a blower door test and visual inspection.

IAQ 4: If installed, fireplace has ducted outdoor air supply with damper

Purpose

If installed, all fireplaces should be installed with an air inlet designed to provide combustion air during operation to support adequate operation.

Criteria

All fireplaces must use a supply duct supplying outside air for combustion that complies with the fire code.

The combustion air inlet shall be equipped with a manual or mechanical damper that may be opened during operation of the fireplace and closed when the fireplace is not in use. Damper control shall be labeled for occupant use.

Confirmation

The EarthCraft technical advisor will visually confirm compliance during the mid-construction review and final field inspections.

IAQ 5: If in EPA Radon Zone 1, install a passive radon/soil gas vent system to exterior and label it clearly

Purpose

Radon is a naturally occurring radioactive gas that is present in the ground at varying concentrations across the country. It has been identified as one of the major causes of lung cancer, and homes susceptible to radon gases should be designed to prevent its entry into the home. This is accomplished through complete air sealing and venting of soil gases to separate the ground from the conditioned space.

Criteria

Required only if home is located in Radon zone 1, as defined by EPA Map of Radon Zones. The passive radon vent shall be installed to vent soil gases through the roof and shall be clearly marked as a Radon Vent.

Additional Resources

- EPA's map of radon zones, including state Radon Information and contacts can be found [here](#).
- EPA's "Building Radon Out" can be found online [here](#).

Confirmation

The EarthCraft technical advisor will visually confirm compliance during the mid-construction inspection.

Example

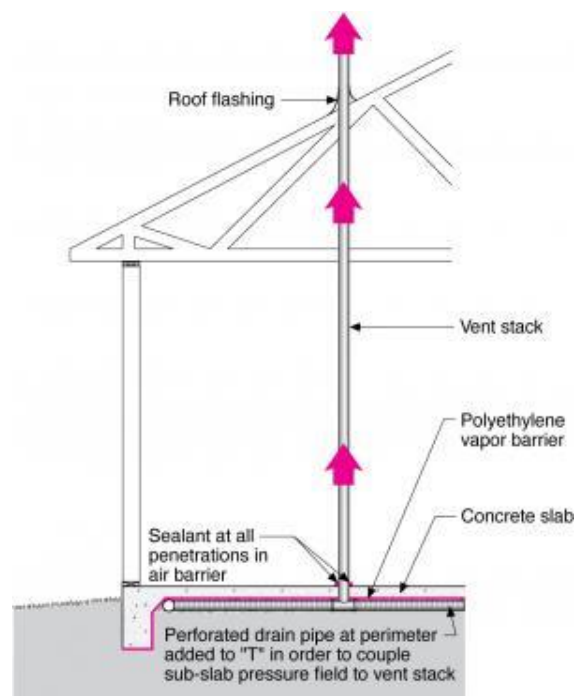

This is an example of a passive radon gas vent system.

IAQ 6: Low- or no-formaldehyde content for finishes (choose one, details below):

- Interior trim
- Flooring
- Cabinets and countertops

Purpose

Formaldehyde is a colorless, flammable gas (at room temperature) which has a strong odor and is found in resins used in the manufacture of composite wood products and building materials. Exposure to formaldehyde may cause adverse health effects, primarily, irritation of skin, eyes, nose and throat. High levels of exposure may cause some types of cancers.

Criteria

Install composite wood products certified as compliant with formaldehyde emissions for at least one of the following:

- California Airborne Toxic Control Measure to Reduce Formaldehyde Emissions from Composite Wood Products Section 93120
- ANSI/HPVA HP-1-2009
- Kitchen Cabinet Manufacturers Association (KCMA) Environmental Stewardship Program (ESP) 05-12
- GREENGUARD or GREENGUARD GOLD

At least 90% of a product must meet this requirement to be accepted.

Confirmation

- The builder must present product documentation demonstrating compliance of product criteria to the EarthCraft Technical Advisor at the final inspection.
- The EarthCraft Technical Advisor will review documentation provided by the builder for compliance of criteria and visually confirm compliance of criteria at final inspection.

IAQ 7: Low- or no-VOC content (choose one, details below):

- Interior paints
- Stains and finishes
- Sealants and adhesives
- Carpet, carpet pad and carpet adhesive

Purpose

Interior paints and finishes may contain volatile organic compounds (VOCs) that can be harmful to humans, such as urea formaldehyde (UF), benzene, toluene, and other chemicals. VOCs from interior finish materials are released into the indoor air, creating unpleasant and sometimes toxic odors, with both short- and long-term health effects for workers and occupants. To protect indoor air quality for both occupants and contractor staff, the best approach is to limit use of VOC-containing materials by specifying and purchasing low- or no-VOC products. Paints, sealants, coatings and adhesives are building products that traditionally contain VOCs.

Criteria

Use only interior paints and finishes that are certified as low- or no-VOC by at least one of the following:

- CA Section 01350 (CDPH Standard Method V1.1-2010)
- Green Seal Standard GS-11
- Green Wise or Green Wise Gold
- GREENGUARD or GREENGUARD Gold Certification for Paints and Coatings
- Master Painters Institute (MPI) Green Performance Standards X-Green, GPS-1 or GPS-2
- Scientific Certification Systems (SCS) Standard EC-10.2-2007 or Indoor Advantage Gold

Use only sealants and adhesives that are certified as low- or no-VOC by at least one of the following:

- CA Section 01350 (CDPH Standard Method V1-1-2010)
- Green Seal GS-36
- GREENGUARD or GREENGUARD Gold adhesives and sealants

Use only carpet, carpet pad and carpet adhesives that are certified as low- or no-VOC by the Carpet and Rug Institute, Inc (CRI):

- CRI Green Label Plus for carpet and carpet adhesives
- CRI Green Label for carpet pad

In order to qualify, ≥90% of the interior surface covered by site-applied paints, coatings, sealants or carpet shall use low- or no-VOC products certified by one or more of the third-party standards listed above.

Additional Resources

- CA Section 01350: <http://www.calrecycle.ca.gov/greenbuilding/specs/section01350/>
- Carpet and Rug Institute, Inc: <http://www.carpet-rug.org/>
- Green Seal: <http://www.greenseal.org/>
- Green Wise Paint: <http://greenwisepaint.com/>
- GREENGUARD: <http://greenguard.org/en/index.aspx>
- Master Painters Institute: <http://www.paintinfo.com/index.asp>
- Scientific Certification Systems (SCS): <https://www.scsglobalservices.com/>

Confirmation

- The builder must present documentation demonstrating compliance of criteria to the EarthCraft Technical Advisor prior to submitting project for certification.
- The EarthCraft Technical Advisor will review documentation provided by the builder for compliance of criteria.

HLTH 1: Install whole building ventilation (choose one):

- Energy recovery ventilator
- Whole house ventilating dehumidifier
- Central fan integrated system with \geq MERV 8 filter for outdoor air prior to crossing HVAC heat exchanger/coils. HVAC system must be equipped with variable speed fan motor and thermostat control.
- Balanced system with monitoring controls for outdoor air humidity and/or temperature
- Supply system with monitoring controls for outdoor air humidity and/or temperature and \geq MERV 6 filter for outdoor air prior to entering conditioned space

Purpose

Whole-house ventilation introduces fresh air into living spaces to dilute pollutants that cannot be removed completely through spot ventilation and/or filtration, thus providing for a healthy indoor environment. Advanced whole building ventilation systems account for outdoor air humidity through built-in air tempering, dehumidification and/or sensor controls.

Criteria

Install a whole building ventilation system designed to meet the air flow requirements of ASHRAE 62.2-2016. Refer to IAQ 1 for CFM sizing information. Projects seeking the Health badge shall install a system design meeting HLTH 1. All air flow CFM verification testing shall comply with ASHRAE 62.2-2016.

Confirmation

The HVAC Manual J Load Calculation shall include whole building ventilation CFM based on the calculations in ASHRAE 62.2-2016. The Technical Advisor will review the Manual J report to verify system has been designed for ventilation airflow. At final, Technical Advisor shall field verify that installed ventilation airflow CFM meets the minimum continuous airflow required.

Note:

- Projects may design whole building ventilation CFM using the infiltration credit in ASHRAE 62.2-2016. Technical Advisor shall review Manual J input for reasonableness, and at final shall field verify actual building envelope infiltration and ventilation airflow CFM. If necessary, whole building ventilation shall be field adjusted to comply with ASHRAE 62.2016.
- Projects using the Prescriptive Duct Sizing Table for local exhaust shall document compliance with photo documentation capturing $\geq 75\%$ of the distribution system

HLTH 2: All exhaust fans in full bathrooms designed and installed to activate by humidistat, motion sensor, or timer

Purpose

A humidistat helps monitor and maintain the set or preferred indoor relative humidity in the air without the need for occupant-initiated operation. Motion sensors provide intermittent spot-exhaust automatically when the occupant is generating pollutants and/moisture. Timers require manual operation, but provide exhaust for a predetermined length of time and prevent fans from operating continuously.

Criteria

Install a bath fan with indoor air humidity control (i.e., a humidistat, motion sensor, or timer) for all bathrooms with tubs and showers.

Provide information on type of system, maintenance, and monitoring requirements in project-specific owner's manual.

Confirmation

The EarthCraft Technical Advisor will visually confirm compliance of criteria at final inspection.

Note: Local exhaust CFM shall meet ASHRAE 62.2-2016. Refer to IAQ 1 for sizing requirements.

HLTH 3: Sealed combustion, direct-vent fireplace(s) or no fireplace

Purpose

In order to ensure good indoor air quality, all fireplaces must be sealed combustion units, as opposed to naturally aspirated units. These systems are completely decoupled from the interior environment through the use of dedicated outdoor air intake and exhaust ducts connected directly to the unit and gasket sealed doors. This design completely disconnects the combustion process from the interior environment, and minimizes concerns of backdrafting of the unit into conditioned space.

Criteria

All installed fireplaces must meet indoor air quality guidelines below and be sealed combustion, direct-ventilation with permanent, gasketed door.

OR

Do not install a fireplace.

Clarification

Fireplaces that meet these guidelines include:

- Gas or propane powered, sealed combustion and direct or power vented as rated by the American Gas Association (AGA) with a permanently affixed glass front.

Confirmation

The EarthCraft Technical Advisor will visually confirm compliance of criteria at final inspection.

HLTH 4: HVAC system designed for \geq MERV 13 pleated filter with minimum 2" filter slot

Purpose

Pleated air filters are more effective than other mechanical air filters because they contain more fiber per square inch than mechanical air filters. This provides a greater surface area and lower resistance to air flow.

Criteria

Design HVAC system for a \geq MERV 13 filtration (according to ASHRAE 52.2) on all HVAC systems. Filter slot must be designed to accommodate installed filter.

Clarification

HVAC design and installation must account for airflow based on filter selection.

Confirmation

The EarthCraft Technical Advisor will visually confirm compliance of criteria at mid-construction and final inspections.

HLTH 5: Follow the below garage ventilation guidelines (Choose one. Details below):

- Attached garage: Install exhaust fan vented to exterior with on/off control by motion sensor or timer
- Detached garage or no garage

Purpose

Attached garages have the potential to allow carbon monoxide and other pollutants to enter the living space. As a good practice, mechanical ventilation should be provided in any attached garage to vent combustion products produced by vehicles.

Criteria

Attached garage: Install exhaust fan vented to exterior with on/off control by motion sensor or timer:

- Install an exhaust fan in an attached garage that operates continuously or operates whenever the garage is occupied and for at least 1 hour after the garage has been vacated.

Detached garage or no garage

- Isolate the garage by a minimum of 4' from the exterior walls or exterior floor of any conditioned area of the house OR
- Design and construct home with an open-carport or no garage

Clarifications

- If operating continuously, install an ENERGY STAR certified fan that is rated at a minimum of 75 CFM.
- If operating whenever the garage is occupied and for at least 1 hour after the garage has been vacated, install fan that is rated at a minimum of 100 CFM of airflow and is controlled by a timer or motion sensor.

Confirmation

The Technical Advisor will confirm compliance during the mid-construction inspection and verify compliance during the final inspection.

HLTH 6: No added urea-formaldehyde in all shelves and countertops

Purpose

Urea formaldehyde is a potentially toxic chemical commonly used as a binder or adhesive in engineered building products.

Criteria

Do not install shelves or countertops that contain added urea-formaldehyde. Refer to IAQ 6 for information on products that meet this requirement.

Confirmation

- The builder must present documentation demonstrating compliance of criteria to the EarthCraft Technical Advisor prior to submitting project for certification.
- The EarthCraft Technical Advisor will review documentation provided by the builder for compliance of criteria.

Plumbing and Irrigation (PI)

Conserving finite fresh water resources has become vitally important in both protecting our environment and helping sustain economic growth in our region. The use of certain strategies like water-efficient fixtures, water-efficient landscaping and irrigation, and reusing water on-site through rainwater or gray water systems can significantly reduce a resident's water consumption as well as their utility bills.

The Plumbing and Irrigation section emphasizes the efficient use of potable water indoors and outdoors. An EarthCraft project aims to reduce water waste and storm water run-off. Strategies include drought adapted landscaping, improved plumbing distributions systems and efficient plumbing fixtures.

PI 1: High efficiency water heater (determined by Energy Factor; see chart below):

Purpose

High efficiency water heaters use 10-50% less energy than standard models. To reduce the amount of energy needed for water heating, the builder can install high-efficiency electric or gas water heaters.

Criteria

Install a high efficiency storage water heater that meets the Energy Factor (EF) or Uniform Energy Factor (UEF) requirements in the following table for gas or electric operation:

Tank Size	Gas EF	Electric EF	Gas UEF	Electric UEF
20 - 55 gal	0.65	0.95	0.61	0.92
55 - 100 gal	0.75	1.97	0.76	2.03
< 2 gal	0.82	0.93	0.81	0.91

Confirmation

- The builder must present documentation demonstrating compliance of criteria to the EarthCraft Technical Advisor prior to submitting project for certification.
- The EarthCraft Technical Advisor will review documentation provided by the builder and visually confirm compliance of criteria at final inspection.

Examples

Electric Storage Tank



A high-efficiency heat pump water heater

Gas Storage Tank



A low efficiency gas water heater. If installed, gas tanks must be 100% separated from living space

PI 2: Insulate 100% of hot water pipe with >R-3

Purpose

Installing insulation on hot water lines helps keep the water warm between uses, saving energy and conserving water.

Criteria

Insulate all hot water pipes to R-3 or greater using polyethylene, neoprene, fiberglass or other insulation types. Fit insulation tightly around hot water pipe, face seam down and secure insulation every 2 feet using wire, tape or clamp. Install insulation on all piping elbows to adequately insulate 90-degree bend.

Exemptions

Hydronic heating systems are not required to insulate pipes in slabs or other approved materials intended for radiating heat into home and therefore do not apply to this criteria.

Confirmation

- The builder must present documentation demonstrating compliance of criteria to the EarthCraft Technical Advisor prior to submitting project for certification.
- The EarthCraft Technical Advisor will visually confirm compliance of criteria at mid-construction.

Examples

Correct



Insulate 100% of hot water pipe

PI 3: Heat trap on all storage water heaters

Purpose

Heat traps increase overall efficiency for storage water heaters by preventing heat loss from inside the storage tank when flow stops.

Criteria

If installing a storage water heater, either purchase storage water heater with a heat trap pre-installed or install heat trap on storage water heater.

Clarifications

Appliances equipped with an internal heat trap may be verified through the unit specification sheet supplied by the manufacturer.

Confirmation

The EarthCraft Technical Advisor will visually confirm compliance of criteria at final inspection.

PI 4: Water pressure <60 PSI for fixtures

Purpose

Reduced water pressure saves water, conserves energy, and helps ensure proper operation of fixtures and appliances.

Criteria

Upon installation of the plumbing system, verify that the static service pressure is a maximum of 60 pounds per square inch (psi) (414 kilopascal [kPa]).

Clarifications

Units supplied by a municipal water supply must either use pressure regulating valve (PRV) upstream of all fixture connections or provide documentation from the public water supplier stating that water pressure will not exceed 60 psi.

Units supplied by groundwater wells must meet this requirement by installing a pressure tank.

Confirmation

The builder must present documentation demonstrating compliance of criteria to the EarthCraft Technical Advisor prior to submitting project for certification, or water pressure may be verified during final inspection.

PI 5: WaterSense labeled toilets, showerheads, lavatory faucets and accessories (all must comply; Details below):

- Toilets: ≤ 1.28 gpf
- Showerheads: ≤ 2.0 gpm. Exception: one (1) showerhead may be ≤ 2.5 gpm
- Lavatory faucets: ≤ 1.5 gpm

Purpose

WaterSense is a U.S. Environmental Protection Agency program designed to encourage water efficiency through the use of a special label on consumer products. This label distinguishes the product as one that is beneficial for the environment through design that minimizes water use while meeting specific performance criteria. EPA criteria must be met in order for a product to receive a WaterSense label.

Criteria

WaterSense labeled toilets, showerheads, lavatory faucets and accessories (all must comply; Details below):

- Toilets: ≤ 1.28 gpf
- Showerheads: ≤ 2.0 gpm. Exception: one (1) showerhead may be ≤ 2.5 gpm
- Lavatory faucets: ≤ 1.5 gpm

Additional Resources

A list of WaterSense labeled fixtures can be found [here](#).

Confirmation

- The builder must present documentation demonstrating compliance of criteria to the EarthCraft Technical Advisor prior to submitting project for certification.
- The EarthCraft Technical Advisor will review documentation provided by the builder for compliance of criteria at final inspection and compare to installed fixtures.

PI 6: Irrigation system (details below):

- Must have a weather-based controller
- Does not water hard surfaces such as sidewalks and home foundation

Purpose

Water saving irrigation methods, such as rain sensors and shut-off devices, distribute water much more efficiently to landscaping. This conserves water because these devices are able to adjust their watering to current weather conditions. Overspray should be avoided because the excess water that cannot be absorbed will empty into the streets and local waterways, potentially impacting water quality. Therefore, irrigation systems should be designed to avoid overspray onto impervious surfaces.

Criteria

- Design irrigation system with zones based on water needs in each planting area.
- Do not water hard surfaces such as sidewalks and home foundation. Attention should be given to the sprinklers at the tops and bottoms of sloped areas to prevent runoff.
- Provide weather station or soil moisture sensor on irrigation system
- Equip irrigation systems with technology that inhibits or interrupts operation of the irrigation system during periods of rainfall or sufficient moisture (e.g., rain sensors, soil moisture sensors)

Confirmation

- The builder must present documentation demonstrating compliance of criteria to the EarthCraft Technical Advisor prior to submitting project for certification.
- The EarthCraft Technical Advisor will review documentation provided by the builder for compliance of criteria.

PI 7: All pools or spas must have an appropriate cover

Purpose

Covers over installed pools and spas serve to reduce heat loss and evapotranspiration.

Criteria

Any installed pools or spas must have an appropriate cover. Provide information on type of system, maintenance, and monitoring requirements in project-specific owner's manual.

Confirmation

The EarthCraft Technical Advisor will visually confirm compliance of criteria at final inspection.

Example

Correct



PI 8: Ornamental water features must recirculate water

Purpose

When ornamental water features are included in a project they should be designed to be as energy- and water-efficient as possible through recirculation.

Criteria

Install ornamental water feature that recirculates water from the feature itself and serve a beneficial use.

Provide information on type of system, maintenance, and monitoring requirements in project-specific owner's manual.

Confirmation

The EarthCraft Technical Advisor will visually confirm compliance of criteria at final inspection.

PERF 2: Confirmed HERS H2O Index <85

Purpose

The HERS H2O Index is developed by RESNET (the Residential Energy Services Network) is a measure of the water usage of the rated building as compared to a hypothetical reference building which is built to current code requirements. A score of 100 indicates that the rated building operates the same as the reference home of the HERS Index (a standard new home constructed in 2006). A HERS H2O score of ≤ 85 means that the rated building must use water $\geq 15\%$ more efficiently than current codes requires.

Criteria

Complete the HERS H2O Index section of the HERS model for the home. All required inputs must be provided.

Confirmation

The HERS H2O collects information on indoor and outdoor domestic water use, including all indoor plumbing fixtures, pools and irrigation systems. The following information will need to be provided:

- Indoor plumbing fixture flow rate specifications for kitchen, lavatory, showers and toilets
- Select the vintage for the dishwasher and clothes washer:
 - "ENERGY STAR" if the appliance is labeled, "Standard" if appliance is less efficient than ENERGY STAR minimum, or "Best Available" if appliance is more efficient than Energy Star. The clothes washer has an additional option, "2008", which represents appliances built to efficiency standards of 2008 and later. If a clothes washer was manufactured in 2008 or later and is not ENERGY STAR rated or more efficient than the minimum ENERGY STAR standard, the "2008" option should be used.
- If project has a hot water recirculation pump, provide specifications on standard system pipe length, loop and branch length and pump watts. Follow RESNET approved procedure for determining pipe lengths:
- If system does not have a recirculation pump, calculate standard pipe length. Input the distance from the hot water to the farthest hot water fixture, measured longitudinally from plans, assuming the hot water piping does not run diagonally, plus 10 feet of piping for reach floor level, plus 5 feet of piping for unconditioned basements.
- If project has an outdoor irrigation system, determine sum of all irrigation flow rates through one of the following:
 - Timed measurement in gallons per day
 - If house has a digital water meter, time flow rate with all taps open to determine gallons per day

Performance Badge (PERF)

- Document if project has an inground pool
- Determine if project uses a water softener

ENV 7: Irrigation (Details below):

- Micro-irrigation system (e.g., drip irrigation) with pressure regulator, filter and flush end assemblies
- Provide weather station or soil moisture sensor on irrigation system

Purpose

Drip irrigation systems use 20% to 50% less water than conventional pop-up sprinkler systems and can save up to 30,000 gallons per year by delivering low volumes of water directly to plants' roots, minimizing losses to wind, runoff, evaporation, or overspray.

Weather-based irrigation controllers, which employ a "smart" irrigation control technology that uses local weather data to determine when and how much to water, can save an average home over 7,500 gallons annually. Soil moisture sensors measure the moisture in the soil and tailor the irrigation schedule accordingly. Also consider rain sensors and rainfall shut-off devices that turn off irrigation on rainy days.

Criteria

1. If installed, micro-irrigation system (a low-pressure irrigation system that sprays, mists, sprinkles or drips) includes a pressure regulator, filter and flush end assemblies. Micro-irrigation shall be installed on separate zones from the rest of the irrigation system if sprinkler heads are used in other parts of the landscape.

AND

2. Provide a weather station or soil moisture sensor on the irrigation system. Refer to credit WE6 for explanation on weather-based controllers

Confirmation

- The builder must present documentation demonstrating compliance of criteria to the EarthCraft Technical Advisor prior to submitting project for certification.
- The EarthCraft Technical Advisor will visually confirm compliance of criteria at final inspection.

Lighting and Appliances (LA)

Approximately 65 percent of U.S. electricity is generated by burning coal and natural gas, which releases greenhouse gases and other air pollutants into the atmosphere, contributing to climate change and air quality problems. Lighting and appliances use a significant amount of energy in buildings and selecting ENERGY STAR certified products, which use less energy than conventional models, and high-efficacy lighting can significantly lower residents' electricity consumption and their energy bills.

LA 1: High-efficacy lighting in $\geq 90\%$ of all permanent indoor and outdoor fixtures

Purpose

Efficacy is the ratio of light produced to the amount of energy consumed. The higher the efficacy, the more light is produced for a given amount of energy - this results in reduced electric bills for home owners and longer bulb lifespans.

Criteria

Install high-efficacy lighting in $\geq 90\%$ of all permanent fixtures. High efficacy lighting includes compact fluorescent bulbs, LED bulbs, T-8 or smaller diameter linear fluorescent bulbs, or bulbs with a minimum efficacy of:

- 60 lumens per watt for bulbs over 40 watts
- 50 lumens per watt for bulbs from 15 watts to 40 watts
- 40 lumens per watt for bulbs 15 watts or less

Clarification

Any bulb that is ENERGY STAR rated will qualify

Additional Resources

Explanation of high-efficacy lighting can be found [here](#).

Confirmation

- The builder must present documentation demonstrating compliance of criteria to the EarthCraft Technical Advisor prior to submitting project for certification.
- The EarthCraft Technical Advisor will review documentation provided by the builder for compliance of criteria at final inspection.

Examples

Correct



LA 2: If installed, ENERGY STAR qualified dishwasher

Purpose

ENERGY STAR dishwashers must exceed the minimum federal efficiency standards for both energy and water use. A new ENERGY STAR certified dishwasher uses less than half as much energy as washing dishes by hand and saves nearly 5,000 gallons of water a year.

Criteria

All installed dishwashers must be ENERGY STAR qualified.

Clarification

As products and ENERGY STAR qualifications are periodically updated, the product must be labeled as an ENERGY STAR qualified product at the time it was purchased.

Additional Resources

A list of qualified products can be found [here](#).

Confirmation

- The builder must present documentation demonstrating compliance of criteria to the EarthCraft Technical Advisor prior to submitting project for certification.
- The EarthCraft Technical Advisor will review documentation provided by the builder for compliance of criteria and will visually confirm compliance of criteria at final inspection.

LA 3: If installed, ENERGY STAR qualified refrigerator

Purpose

ENERGY STAR refrigerators are about 9% more energy efficient on average than models that meet the federal minimum energy efficiency standard.

Criteria

All installed refrigerators must be ENERGY STAR qualified.

Clarification

As products and ENERGY STAR qualifications are periodically updated, the product must be labeled as an ENERGY STAR qualified product at the time it was purchased.

Additional Resources

A list of qualified products can be found [here](#).

Confirmation

- The builder must present documentation demonstrating compliance of criteria to the EarthCraft Technical Advisor prior to submitting project for certification.
- The EarthCraft Technical Advisor will review documentation provided by the builder for compliance of criteria and will visually confirm compliance of criteria at final inspection.

LA 4: If installed, ENERGY STAR qualified clothes washer (water factor ≤ 6.0 gal)

Purpose

ENERGY STAR certified clothes washers save on energy and water costs — they use about 40% less water and about 25% less energy than a regular washer.

Criteria

Select an ENERGY STAR-rated washer and compare efficiencies between units by using the EnergyGuide label.

All installed clothes washers must be ENERGY STAR qualified with a water factor of less than or equal to 6.0 gallons.

Clarification

As products and ENERGY STAR qualifications are periodically updated, the product must be labeled as an ENERGY STAR qualified product at the time it was purchased.

Additional Resources

A list of qualified products can be found [here](#).

Confirmation

- The builder must present documentation demonstrating compliance of criteria to the EarthCraft Technical Advisor prior to submitting project for certification.
- The EarthCraft Technical Advisor will review documentation provided by the builder for compliance of criteria and will visually confirm compliance of criteria at final inspection.

Education and Operations (EO)

An EarthCraft house can provide a homeowner with increased occupant comfort and well-being, as well as energy savings from improved building performance, but without proper homeowner education these benefits may not be fully realized.

The Education and Operations section focuses on providing a homeowner with the necessary materials and manuals to properly operate their home's systems in order to maximize energy and water performance and promote occupant health. Additionally, homeowner education provides resources on specific EarthCraft strategies and features. This section helps to ensure that the EarthCraft program is marketed and represented accurately in the public realm.

EO 1: Provide homeowner with project-specific owner's manual

Purpose

The homeowner's manual is a resource available to homeowners that outlines the proper operation and maintenance for the various systems, equipment and EarthCraft features of their home.

Criteria

Manual must contain, at a minimum, the following:

- Instructions for proper HVAC system operation and maintenance
- Instructions for proper operating procedure for irrigation system
- Overview of general home maintenance activities and frequency
- A copy of the EarthCraft certificate

Clarification

Equipment manuals are acceptable, but shall be supplemented with clear and specific instructions to the homeowner on when and how equipment shall be used.

Additional Resources

EarthCraft has a template available for download at www.earthcraft.org/earthcraft-professionals/resources

Confirmation

- The builder must present documentation demonstrating compliance of criteria to the EarthCraft Technical Advisor prior to submitting project for certification.
- The EarthCraft Technical Advisor will review documentation provided by the builder for compliance of criteria.

EO 2: EarthCraft House Certified Builder

Purpose

To ensure that each house is completed by a builder that is familiar with the EarthCraft standards and expectations, builders must be certified by EarthCraft and satisfy all applicable credential requirements.

Criteria

The home must be constructed by an EarthCraft Certified Builder that is in good standing with program administrators.

Clarification

EarthCraft administrators will verify this requirement at registration. A project registration will not be processed if this requirement is not met.

Additional Resources

Information on how to become an EarthCraft builder and credential maintenance can be found at <https://www.viridiant.org/residential-programs/current-earthcraft-builder-certification-process/>

Confirmation

Once project registration is submitted, EarthCraft administrators will confirm the builder associated to that project is certified and in good standing.

EO 3: Market EarthCraft House program

Purpose

Marketing the EarthCraft House program helps educate the local market and drive continued demand for high performance development.

Criteria

Include EarthCraft House logo in all print materials, websites, advertisements and other promotional materials associated with project promotion.

Post an EarthCraft House sign in the front yard of the home during construction.

Clarification

Technical Advisors will verify that proper on-site marketing (i.e. EarthCraft House sign) is installed in the front yard of the home during construction.

Additional Resources

The EarthCraft logo may be requested by reaching out to marketing@earthcraft.org. All additional marketing resources can be found at www.earthcraft.org/earthcraft-professionals/resources/marketing-logo-guidelines/

Confirmation

The EarthCraft Technical Advisor will verbally and visually confirm compliance of criteria with the builder at the pre-drywall and final inspections.



Net-Zero Program™

Viridiant’s Net-Zero Certification program offers unparalleled support to project teams during the design and construction process. The program is targeted to builders, designers and homeowners throughout the Southeast who believe in superior building and the next generation of housing. The program consists of a two part certification; “Net-Zero Ready” once the project has successfully met the program design criteria, construction and diagnostic testing goals, and “Net-Zero Certified” once the homeowners have demonstrated (documented in real time utility tracking) that they have lived an energy neutral or positive lifestyle for one year.

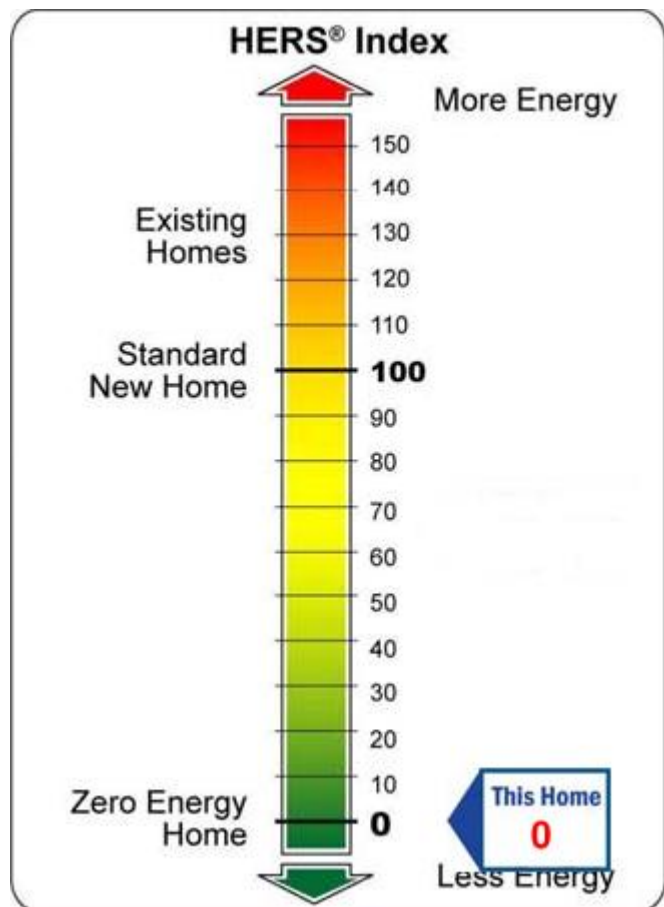

For more information regarding this program, please contact us at admin@viridiant.org or (804) 225-9843.

Featured Project: Grissom Lane, Blacksburg, VA

By Community Housing Partners





community which does not have any subsidized affordable senior housing. Residents that live or work in Montgomery County will be given first preference for the housing. Grissom Lane is within an established mixed income community in Blacksburg with existing utility infrastructure and public bus service. The housing will be compatible with the character of the neighborhood and provide outdoor gathering, walking and gardening spaces for residents.

These homes are being designed to produce as much energy as they consume on an annual basis and are part of Viridiant's Net-Zero pilot program. High insulation values, extensive air sealing, Energy Recovery Ventilators (ERV) and mini-splits are used to reduce the energy demand on the homes.

The apartments will be designed using Universal Design features to help facilitate people to stay in their homes longer (age in place). It is desirable to age in place rather than have to move to a form of institutional care. Aging in place is also much less costly to both the individual and society than institutional care.



Certification

- *Net-Zero Ready* – meet all design, construction, and diagnostic testing criteria
 - *Net-Zero Certified* – 1 year of online energy tracking with energy neutral or positive bills
-
- **Energy Performance** – Net Zero Energy (site energy), HERs Index: ≤ 10
 - Minimum HERs Index prior to renewable systems: ≤ 50
 - **Diagnostic Testing**
 - Infiltration
 - Target - 1.5 ACH50
 - Duct leakage
 - $\leq 2\%$ leakage to the outside, 10% system airflow capacity leakage
 - **Envelope**
 - Meet or exceed 2012 IECC criteria including RESNET Grade I insulation
 - Windows
 - UValue – ≤ 0.30
 - SHGC – ≤ 0.27
 - High gain windows for south exposure
 - **HVAC/Ductwork**
 - Manual J, D, and S
 - All ductwork located within the thermal envelope, mastic
 - Commissioning – Ventilation and HVAC (system airflow, refrigerant charge, room- room pressure ± 3 PA)
 - **Ventilation**
 - ASHRAE 62.2-2010
 - **Water Heating**
 - WaterSense™ Indoor Criteria
 - **Lights/Appliances**
 - 75% CFL and/or LED
 - Energy Star Appliances
 - **Renewable Systems**
 - Photovoltaic Array, Solar Thermal, and/or Wind Turbine(s)



FIND AN EARTHCRAFT BUILDER IN YOUR AREA

 Search now





- > [LIHTC QAP](#)
- > [Multifamily](#)
- > [EarthCraft Multifamily](#)
 - > [EarthCraft Multifamily Resources](#)
- > [EarthCraft House](#)
 - > [Become an EarthCraft Builder](#)
 - > [Builder FAQs](#)
 - > [Get Certified](#)
 - > [EarthCraft House Resources](#)
 - > [Single Family Project Registration](#)
- > [EarthCraft Renovation](#)
 - > [EarthCraft Renovation Resources](#)
 - > [Single Family Project Registration](#)
- > [EarthCraft Communities](#)
 - > [EarthCraft Communities Resources](#)
- > [Builder Information Request](#)
- > [LEED®](#)
- > [Net-Zero Program™](#)
 - > [Net Zero Resources](#)
- > [Energy Star®](#)
- > [Energy Promise](#)
- > [HUD MAP](#)
- > [Utility Allowances](#)
- > [Indoor airPlus](#)
- > [WaterSense®](#)
- > [Training Courses](#)
- > [Marketing & Logo Guidelines](#)



viridiant

[HOMEOWNERS](#) [SERVICES](#) [EVENTS](#) [ABOUT](#) [NEWS](#)



[SUPPORT US](#)



viridiant

© 2019 Viridiant. All Rights Reserved.





Arlington Group Home- 100% Construction Document - Whole Building Energy Simulation

Arlington County, New Group Home - 1212 S. Irving
2019-0804

Prepared by:

Roger Frechette, PE, LEED AP BD+C

Kyle Rives, PE, LEED AP BD+C

Arash Zarmehr, LEED Green Associate

Disclaimer: This analysis is not intended to predict the absolute energy consumption of the proposed facility but rather it is intended to estimate the order of magnitude savings for alternative systems and building options based on refined assumptions, building performance metrics, and energy modeling expertise. Change in weather conditions, operational characteristics, end-user, miscellaneous electrical loads, controls alterations and other unpredictable metrics prevent the model from accurately predicting the actual annual energy consumption of any facility.

October 22, 2020

Table of Contents

Executive Summary	1
Approach.....	2
Simulation Requirements	3
Energy Model Criteria.....	4
Results	12
PV Panels Design and Analysis	13
Appendices.....	16

Executive Summary

The county-owned property located at 1212 S. Irving Street is a detached three-level single-family group home that is approximately 5,000 SF. The structure was built in 1924 and consists of seven bedrooms, four bathrooms, a single living room with an adjacent dining room, a full kitchen, and a den. While the residence has seven bedrooms, it is currently licensed to accommodate five individuals; each of whom occupies his or her room. The existing building is to be razed for the construction of a new, modern, energy-efficient building. A new home will replace the existing home at 1212 Irving Street, and provide a primary residence for Arlington adults with developmental disabilities. Upon completion, the new home will continue to provide a primary and permanent residence for up to five individuals with developmental and physical disabilities. The new home will be fully accessible and contain six (6) bedrooms, four (4) private and one (1) shared bathroom, kitchen, dining, and living rooms as well as an office type space for the 24/7 staff on site.

This report discusses the engineering energy analysis performed in support of the Proposed design case criteria. Engineering energy simulations have been performed to assess the project's energy use and savings as compared to a building designed to meet the target of high-performance building. Below is a summary of the results.

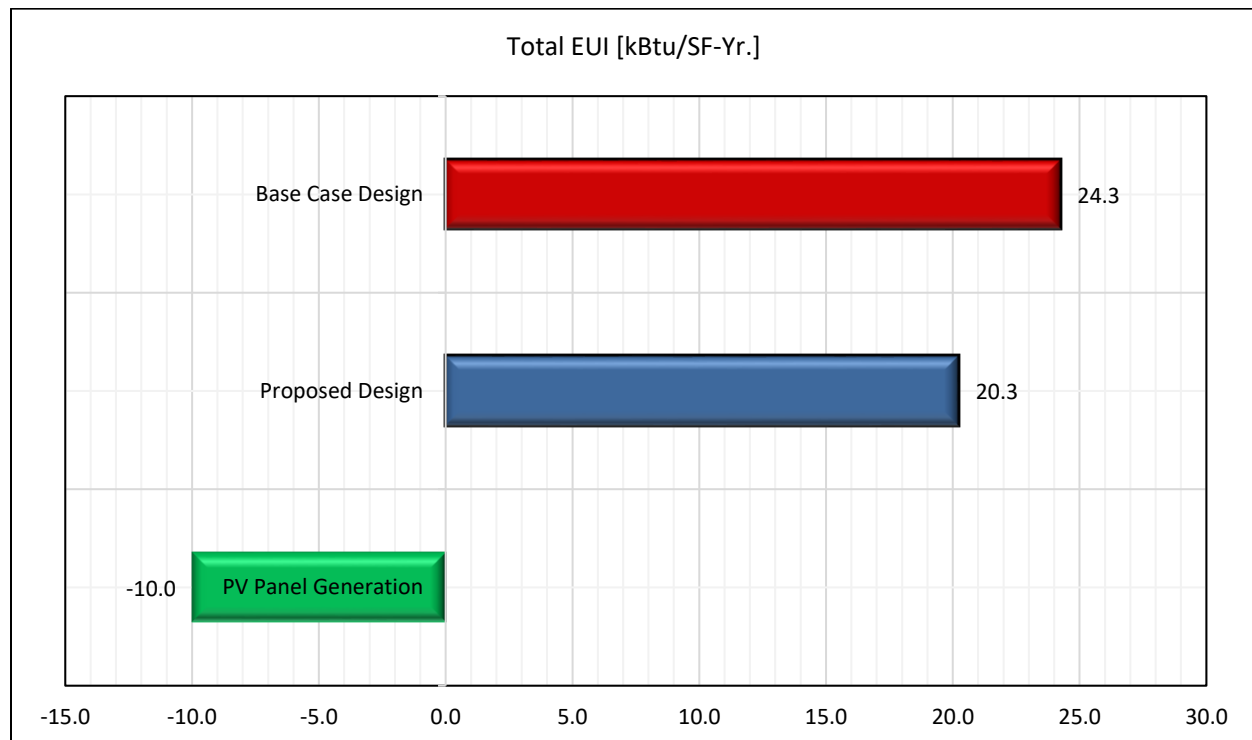

Figure 1. Energy Use Intensity

Type	Baseline Model ¹			Proposed Design Case ²			Percent Savings	
	Energy Use (KBtu/Yr.)	Energy Cost (\$/Yr.)	EUI (kBtu/Sf-Yr.)	Energy Use (KBtu/Yr.)	Energy Cost (\$/Yr.)	EUI (kBtu/Sf-Yr.)	Energy %	Cost %
Total	139,165	4,908	24.3	116,125	4,095	20.26	16.5	16.5
PV Generation³	0	0	0	-57,290	-2,020	-10	-	-
Net Energy Use	139,165	4,908	24.3	58,835	2,075	10.26	49.36	49.3

Table 1. Energy Use Intensity Comparison

1. The base design case model for this project is based on the 2015 Virginia Energy Conservation Code, [based on IECC 2015]
2. Proposed Design case.
3. See PV Design Section for the design detail and Appendix D for module detail.

Approach, Sustainability, and Net-Zero Design

At Interface Engineering, sustainable design is fundamental in our practice, in our project work as well as our internal culture. How to do more with less is always a strategic focal point. Consulting on overall integrated design, we diligently work to reduce demand for urban infrastructure and natural resources. Our goal is to find sustainable, efficient, and pragmatic ways to deliver an optimal environment within the building.

This delivery includes meeting the needs of building owners and occupants in a manner that is viable, sustainable, and cost-efficient. With each project, we search for effective ways to optimize building performance at minimal cost to the owner and the environment. This can be done by making wide use

of available natural energy resources and applying a fully integrated design process. The home is designed to operate at net-zero that is achieved through several energy conservation measures including but not limited to the following:

- enhanced thermal envelope,
- geothermal boreholes,
- water-source heat pumps with ECM motors,
- water to the water heat pump for domestic hot water,
- photovoltaic with electrical infrastructure included,
- energy recovery ventilators,
- LED lighting fixtures,
- low-flow fixtures, & energy star appliances.

Simulation Requirements

Simulation Program

A whole building energy model was created using Energy Plus v.9.2, which satisfies all criteria for energy compliance. This model has been used to perform a series of engineering energy simulations to assess the energy conservation measures being included in the project, to understand their impact and capability of achieving a net-zero energy design target, and to quantify the savings of the proposed design as compared to a Base Case model based on the minimum requirement of IECC 2015.

Energy Compliance

The project will be designed in compliance with the state and local energy codes. This path dictates that all “Mandatory” provisions of Chapter 11 of Virginia Residential Code, Energy Efficiency, shall be followed along with one (1) of the following:

- Sections N1101.14 through N1104.
- Section N1105.
- Section N1106.
- The most recent version of REScheck keyed to the IECC 2015.

Climatic Data

Simulation Weather

The energy simulation utilized a Typical Meteorological Year (TMYx) weather data file acquired from the nearest weather station, Ronald Reagan National Airport, WMO Station #724050. This weather file has been created by the National Renewable Energy Laboratory and contains hourly values for solar radiation, air temperature, and other climate-related variables to appropriately characterize the typical climate for a location to be used in energy simulations. The TMYx weather data represents the average monthly values from a period of 15 years, using hourly inputs from 2004-2018.

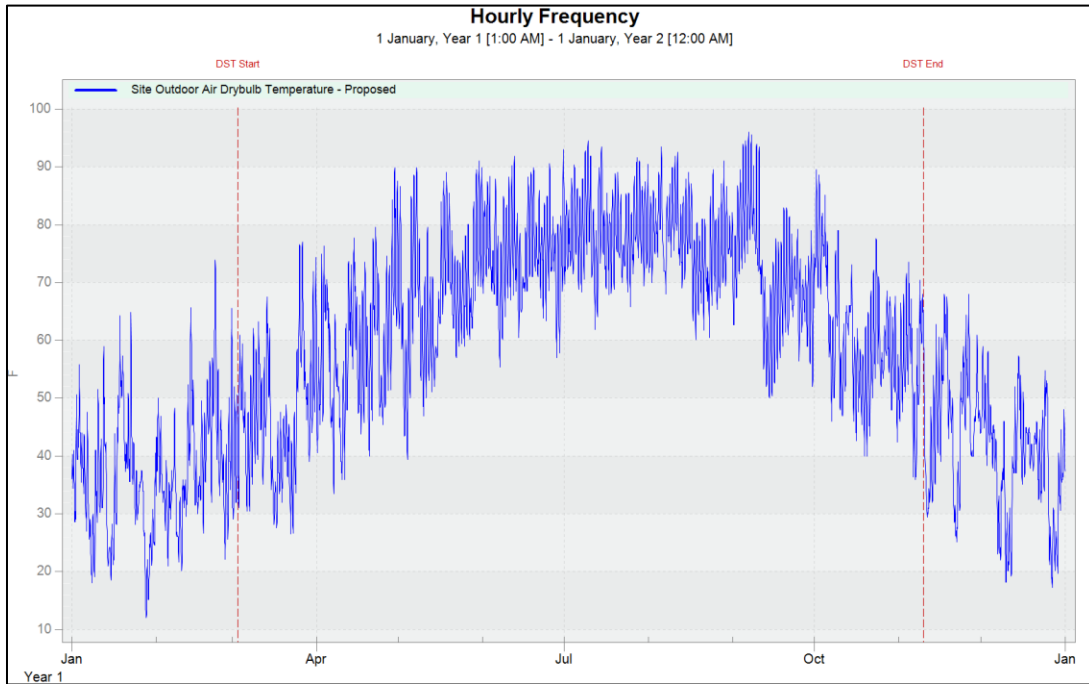

Figure 2. Site Outdoor dry-bulb temperature weather analysis

Energy Rates

This analysis assumes state average utility rates for northern Virginia provided by the Energy Information Agency. The rates used are 12.6 cents / kWh for electricity consumption.

Source: <https://www.bls.gov/regions/mid-atlantic/data/averageenergyprices.htm>

Other Components

Infiltration

- Infiltration target: 1.5 ACH50
- Duct leakage: $\leq 2\%$ leakage to the outside, 10 system airflow capacity leakage

Energy Model Criteria

Design Model

The simulation model of the proposed design is a representation of the actual building architectural design. The baseline building model has been modeled identically as the proposed design, with the same number of thermal zones, occupancy types and fenestration, and opaque envelope areas.

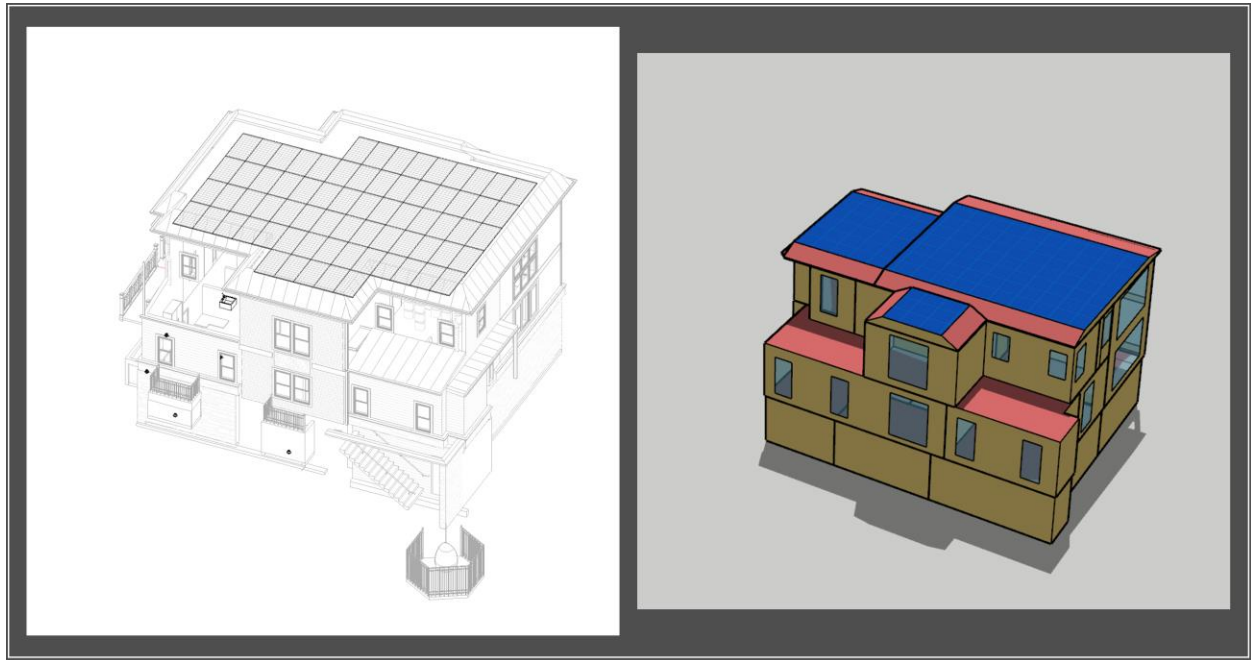

Figure 3. The energy model geometry

Space Use Classification

Per ASHRAE 62.2-2013, Minimum Ventilation Rates in Breathing Zone, default occupancy for dwelling units is assumed to be two persons for studio and one-bedroom units, with one additional person for each additional bedroom.

Building Envelope

Building Envelope Criteria		
	Proposed Design Criteria ¹	Base Case Design Criteria ²
Wall Construction	Wood Frame: R-40 Basement Wall: R-13 Crawl Space Wall – R-13	Wood Frame: R-15 Basement Wall: R-10 Crawl Space Wall – R-10
Floor Construction	Floor: R-19 Slab: R-10 @ 2' in depth	Floor: R-19 Slab: R-10 @ 2' in depth
Vertical Fenestration	U-Value = 0.16 SHGC = 0.31 VLT=55%	U-Value = 0.35 SHGC = 0.40
Roof	Ceiling: R-50	Ceiling: R-38

Table 3. Building Envelope Criteria

1. Values represent preliminary minimum proposed design criteria to be further refined during the design process.
2. Criteria from IECC 2015 [2015 Virginia Energy Conservation Code] Section: R402.1.2 Insulation and Fenestration.

Lighting/ Plug Load

Lighting power in the baseline simulation was assigned to the building area method.

Lighting and General Plug Loads Power Density		
Building Area Type	Proposed Design ¹	Baseline Design ²
Single-family	0.38	0.5

Table 4. Lighting Power Density

1. Design Target- All LED- (Calculated from https://www.energy.gov/sites/prod/files/2014/03/f13/house_simulation_protocols_2014.pdf).
2. 75% CFL and/or LED -Minimum Viridiant Net-Zero requirements.

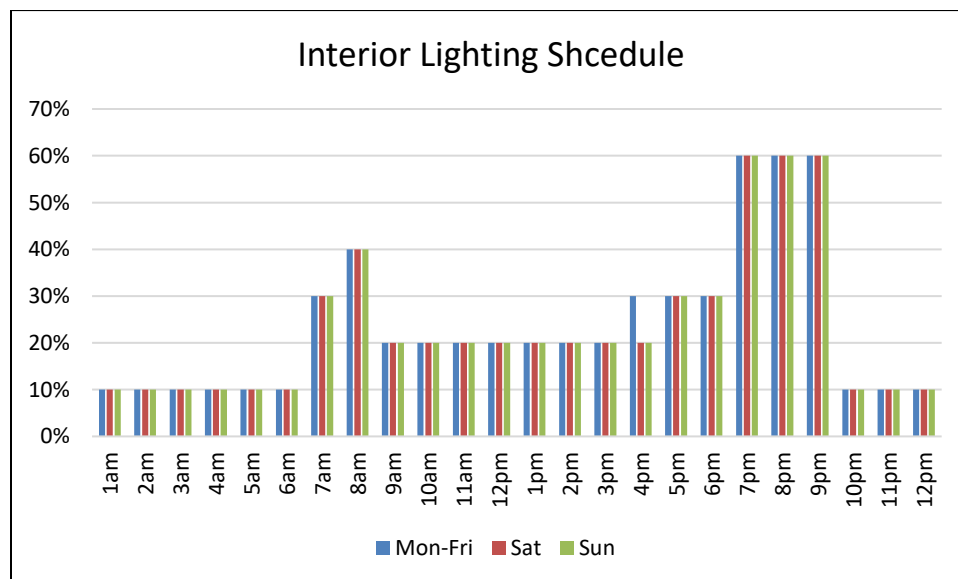

Figure 4. Interior Lighting Schedule

General Plug Load Power Density		
Building Area Type	Proposed Design ¹	Baseline Design ²
Single-family	0.5	0.5

Table 4. Plug Load Power Density

1. Design Target –(Calculated from https://www.energy.gov/sites/prod/files/2014/03/f13/house_simulation_protocols_2014.pdf).

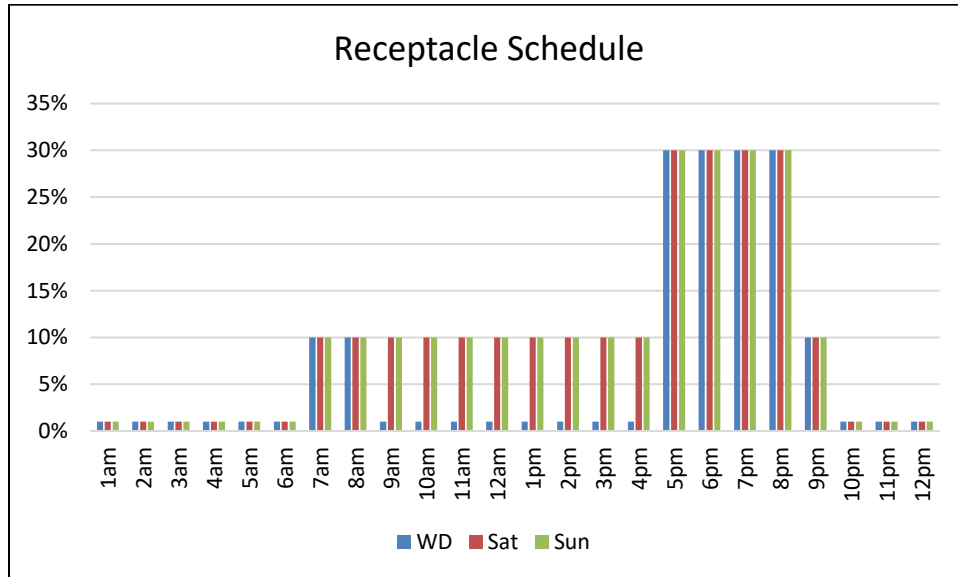

Figure 5. General Plug Load

Appliances Loads

Category	Sub-Category	Consumption [watts]
Laundry Circuit		
	Washer	1800
	Dryer	7200
Appliances		
	Range (cooktop and oven)	3000
	Garbage Disposal	380
	Microwave	1200
	Dishwasher	1200
	Refrigerator	400

Source: Electrical design documents

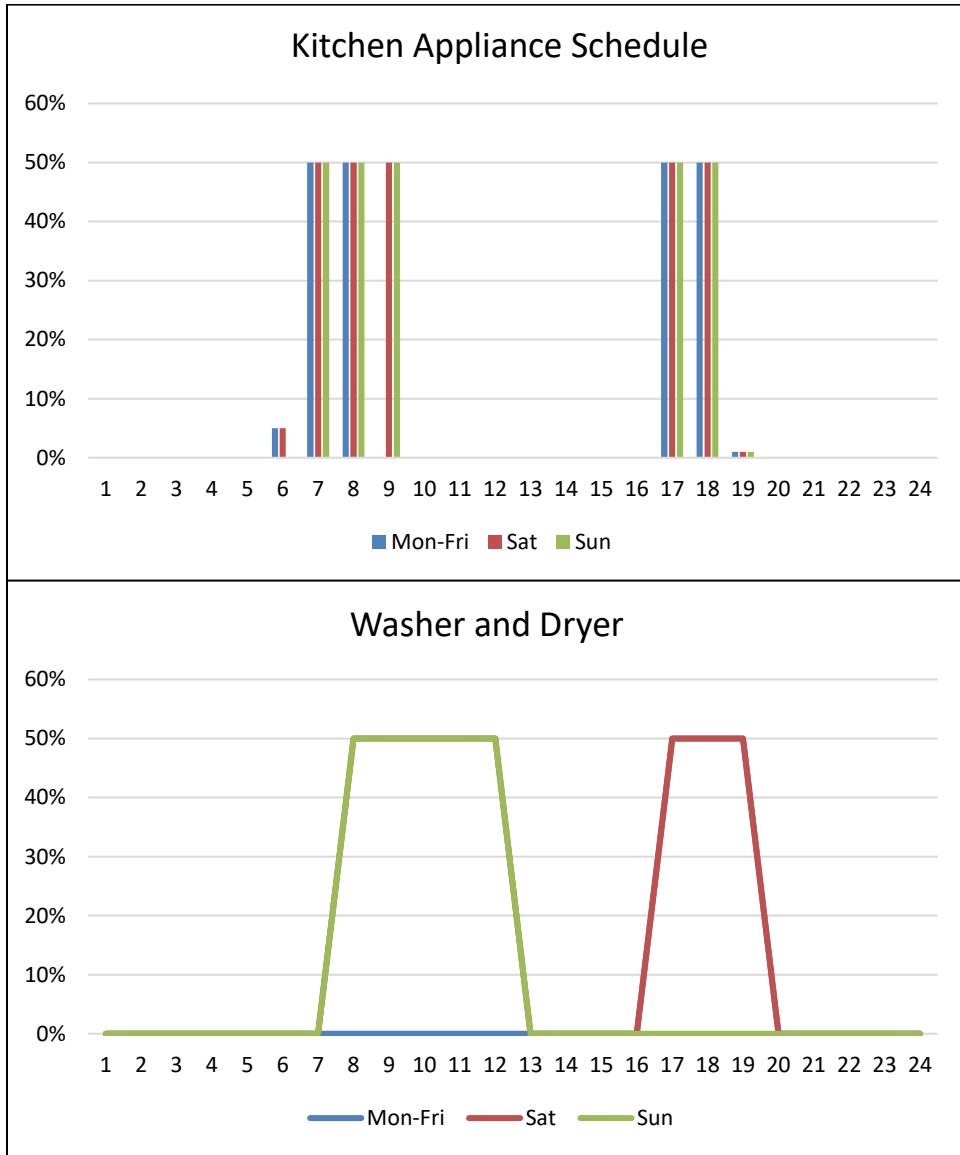

Figure 6. Appliances schedule

Elevator

This building will have one elevator with a 5 HP motor, resulting in peak demand for approximately 3728.5 W.

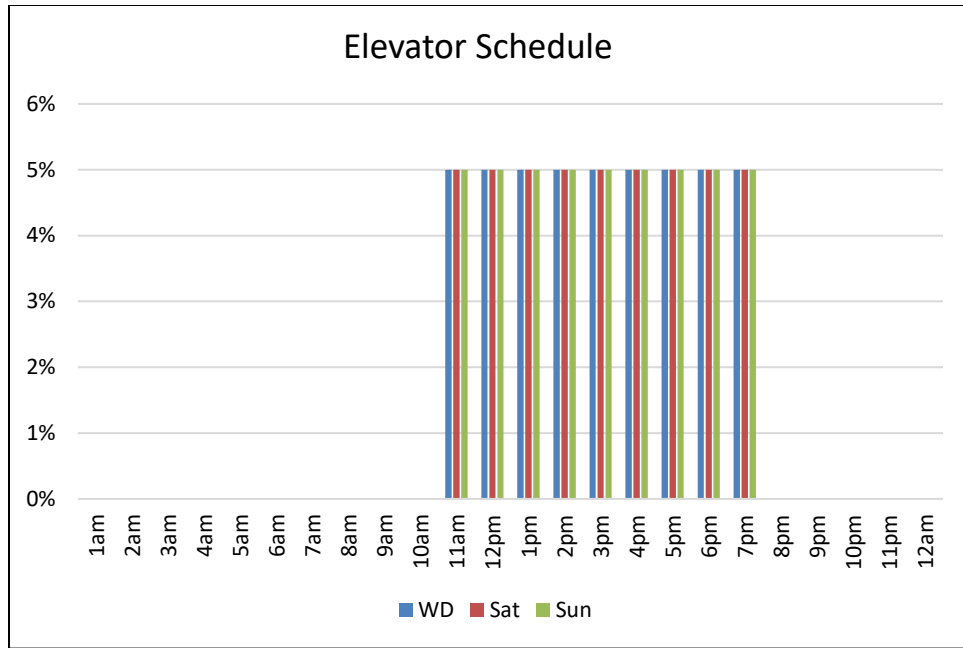

Figure 6. Appliances schedule

HVAC Systems

HVAC Description		
	Proposed Design ¹	Baseline ²
HVAC System	<ul style="list-style-type: none"> ➤ Geothermal-Exchange, Water Source Heat Pump (WSHP) A geothermal-exchange water source heat pump is an indoor air handler connected to a geothermal field for heat absorption and rejection. The geothermal-exchange WSHP is a high-efficiency HVAC system that utilizes condenser water for a heat transfer medium within the system. Upon exiting the WSHP, the condenser water loop will enter the geothermal field where the temperature of the water will either rise or fall depending on the season. Geothermal heat pumps use the earth as a heat source in the winter and as a heat storage source in the summer. ➤ Energy Recovery Unit (ERV) One for each WSHP. The ERV will be connected to the return air ductwork of the WSHP and will provide the code required for outdoor air to the unit. 	The Same as Proposed

Table 5. HVAC Description

1. HVAC systems based on the Mechanical Design set (See Appendix C).
2. See Appendix B

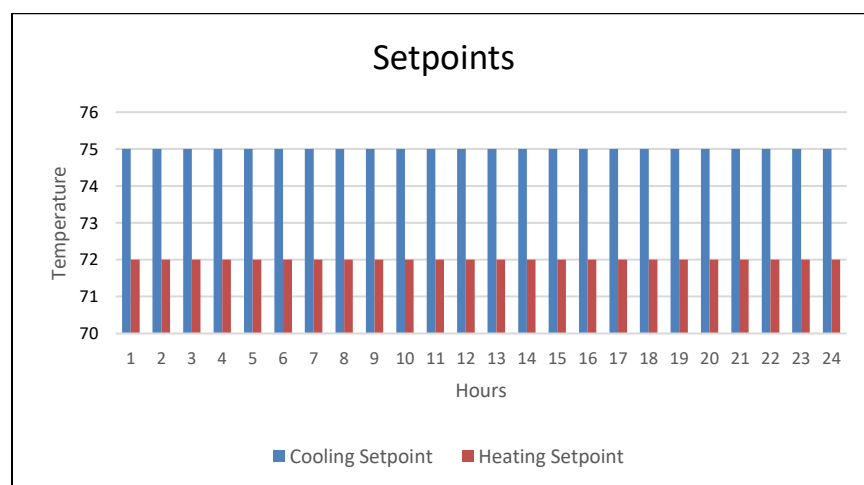

Figure 8. Cooling and Heating Setpoint

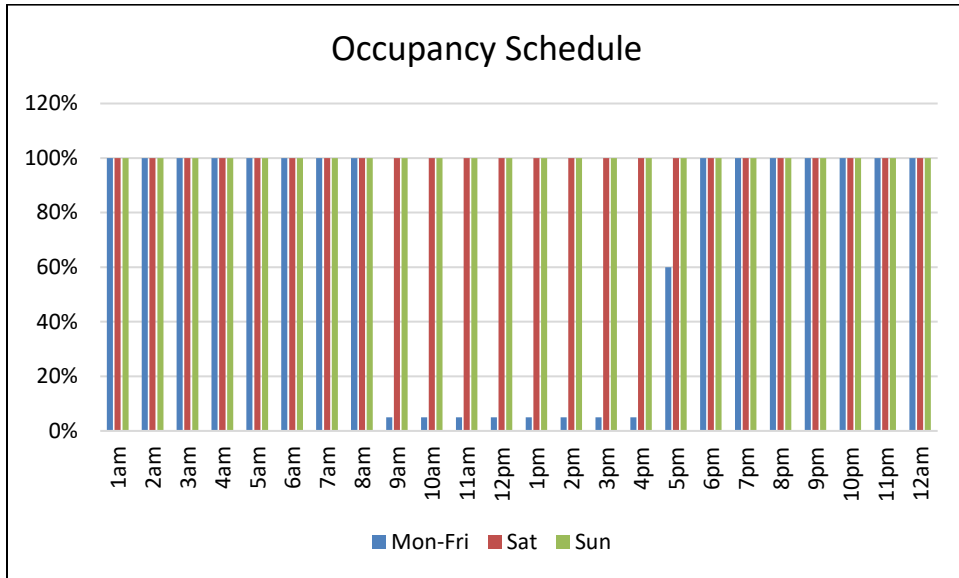

Figure 9. HVAC Operation and Occupancy Schedule

Geothermal Field

It is anticipated that the geothermal field will need to have a capacity of approximately 8 tons (factoring in efficiency losses) to provide the necessary heating/cooling for the WSHPs. The geothermal loop field will be located under and/or adjacent to the building and consist of approximately 5 boreholes (wells) each approximately 300 - 400 feet deep. The boreholes shall be spaced 20-25 feet apart on center thus taking up approximately 2400 SF. The piping circuits shall be routed into a manifold located within the basement along with the other mechanical equipment. A condenser water pump of approximately 5 HP shall be used to circulate the water between the geothermal field and the WSHP.

Kitchen Exhaust

The kitchen hood shall be exhaust directly to the outdoors via a louver in the façade. The hood shall be provided with an integral fan and control switch capable of providing a minimum of 100 CFM of exhaust in compliance with the 2015 Virginia Residential Code.

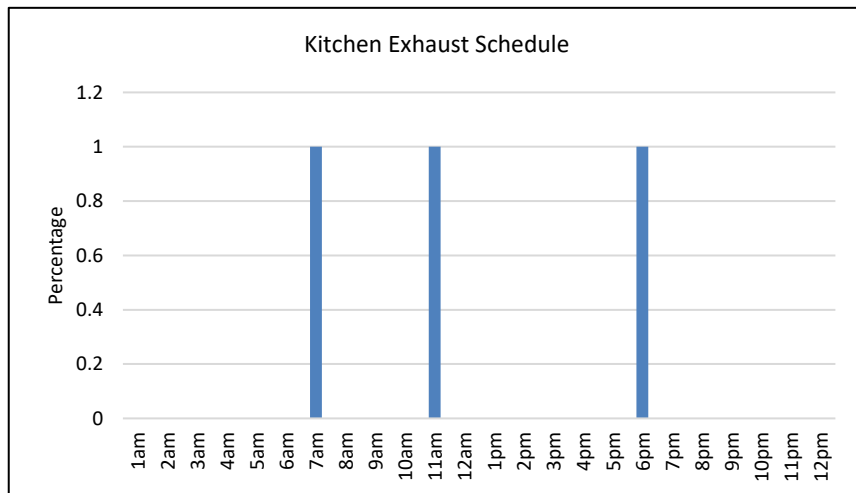

Figure 10. Kitchen Exhaust Schedule

Toilet Exhaust

Mechanical toilet exhaust from each bathroom is required and shall be provided via a ceiling-mounted exhaust fan. The fan shall be operated by a wall-mounted switch and provide a minimum of 50 CFM of exhaust in compliance with the 2015 Virginia Residential Code

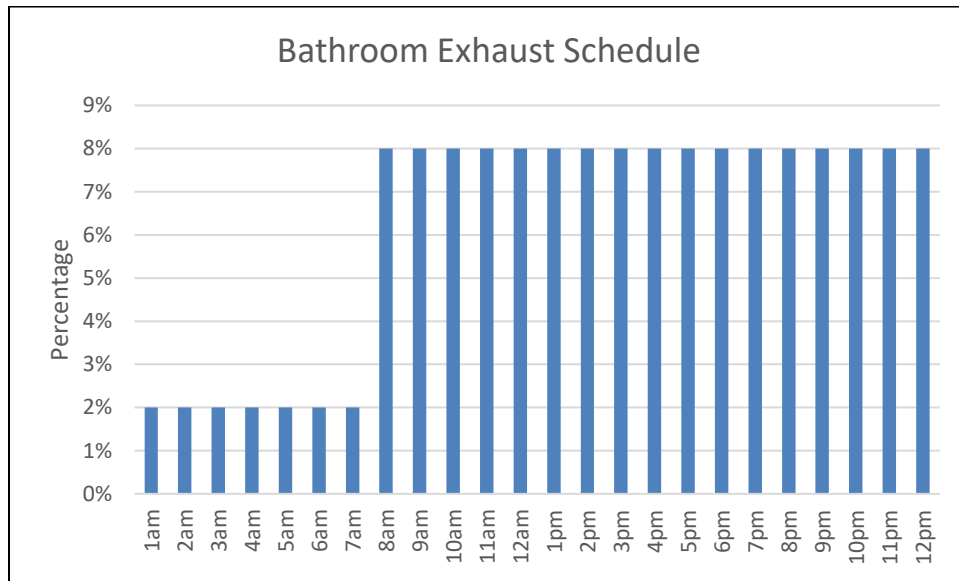

Figure 11. Bathroom Exhaust Fan Schedule

Note: overall estimated to be in use for 2 hours a day

Domestic Hot-Water (DHW) Systems

Water-to-water Heat Pump

This high-temperature water-to-water heat pump is to heat domestic hot water that already uses the geothermal heat pump for space heating and cooling. The high-temperature water-to-water heat pump uses a pre-heated incoming liquid as its energy supply source. The incoming liquid must have a temperature of between 50°F (10°C) and 122°F (50°C). This energy supply source is a buffer tank connected to the indoor side of a geothermal heat pump. The high-temperature water-to-water heat pump takes the preheated liquid and uses it to heat water as high as 160°F (71°C).

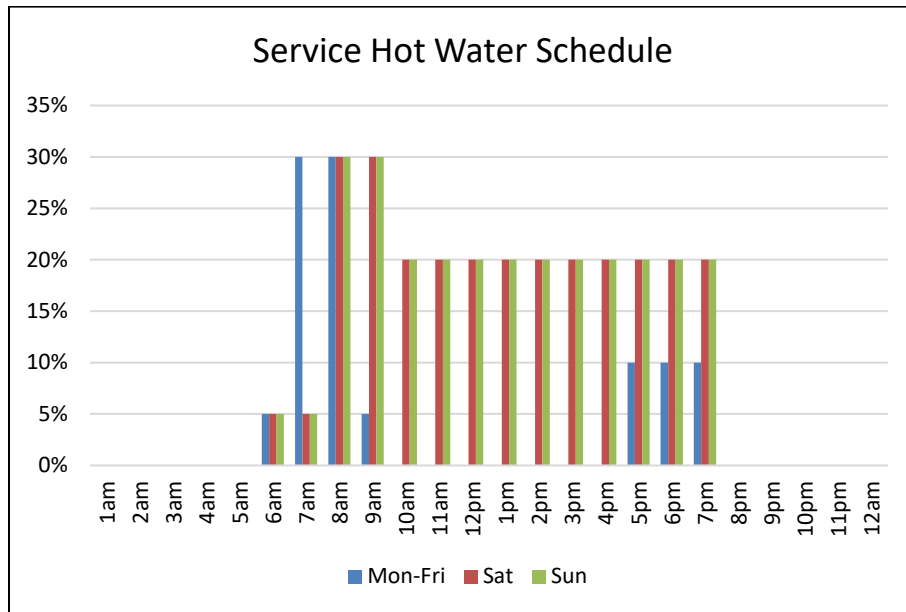

Figure 11. SHW Schedule

Result Analysis

A whole building energy model was created in support of the development of design using Energy Plus v.9.2, which satisfies all criteria for compliance given by the IECC 2015 Performance Approach. Below are the analysis results of the energy use intensity breakdown (See Figure 12).

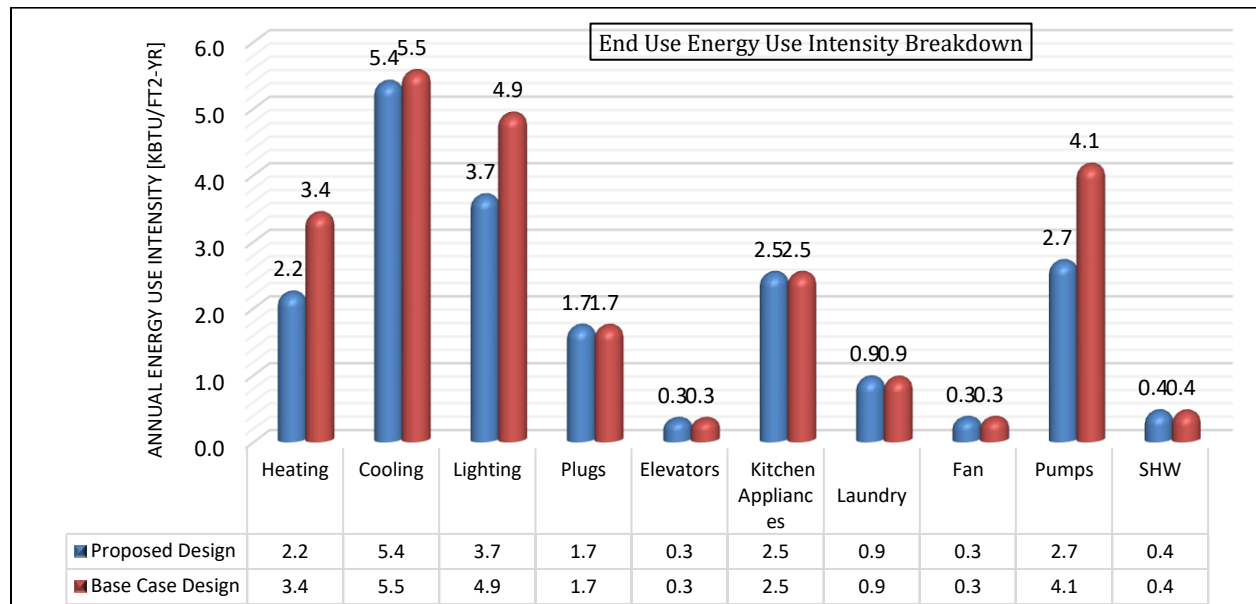

Figure 12. End-Use Breakdown Analysis

Photovoltaic Panels Design and Analysis

For this project, Helioscope which web-based tool is used for PV system sizing and calculations. Helioscope is a web-based software modeling tool developed by Folsom Labs and is capable of modeling various systems such as PV systems. To correctly design and analyze the PV energy generation we have to calculate the available area, weather, and location of the building. IEI (Interface Engineering Inc) with cooperation project teams and stakeholders identified there is enough area on the roof for 40 Panels which each produces 370 watts. For this proposed Sun Power, SPR X22-370 was chosen as a suitable product for this project. The simulation results show the annual electricity generation of 16.79 MWh.

This amount of energy generation is equal to 10 EUI. The energy modeling and simulation shows the EUI of 20.26 [kBtu/Sf-Yr.]. This will consider +10.26 annual energy consumption.

Results	
	EUI [kBtu/SF-Yr.]
Total EUI without PV Panels	20.26
Total EUI with PV Panels	10.26

The following are the detail of the Solar PV simulation.

A. Helioscope Input Summary

Design

Design	Design 2 153 degrees Ballasted vertical dual tilt
DC Nameplate	14.8 kW
AC Nameplate	14.0 kW (1.06 DC/AC)
Last Modified	Joe Schmid (Today at 8:26 AM)

Project Location



Components

Component	Name	Count
Inverters	IQ7A-66-x-240 (Enphase)	40 (14.0 kW)
AC Panels	3 input AC Panel	1
AC Home Runs	12 AWG (Copper)	1 (171.9 ft)
AC Branches	8 AWG (Copper)	3 (118.1 ft)
Module	SunPower, SPR X22-370 (370W)	40 (14.8 kW)

Field Segments

Description	Racking	Orientation	Tilt	Azimuth	Intrarow Spacing	Frame Size	Frames	Modules	Power
Field Segment 1	East-West	Landscape (Horizontal)	8°	152.984°	0.8 ft	1x1	20	40	14.8 kW

Wiring Zones

Description	Combiner Poles	String Size	Stringing Strategy
Wiring Zone	12	1-0	Along Racking

B. Shading Analysis



C. Simulation Results

System Metrics	
Design	Design 2 153 degrees Ballasted vertical dual tilt
Module DC Nameplate	14.8 kW
Inverter AC Nameplate	14.0 kW Load Ratio: 1.06
Annual Production	16.79 MWh
Performance Ratio	73.9%
kWh/kWp	1,134.5
Weather Dataset	TMY, 10km grid (38.85,-77.05), NREL (prospector)
Simulator Version	c724a466fd-c55c2bad74-3319e162ad-49c4c59f12

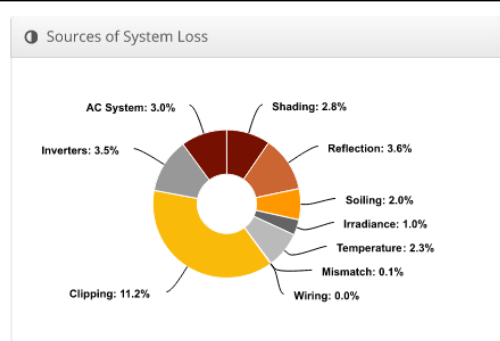
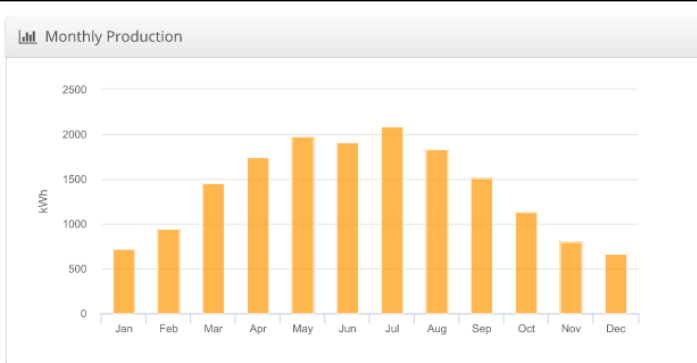

Annual Production			
	Description	Output	% Delta
Irradiance (kWh/m ²)	Annual Global Horizontal Irradiance	1,539.2	
	POA Irradiance	1,535.6	-0.2%
	Shaded Irradiance	1,492.3	-2.8%
	Irradiance after Reflection	1,439.0	-3.6%
	Irradiance after Soiling	1,410.2	-2.0%
	Total Collector Irradiance	1,412.1	0.1%
Energy (kWh)	Nameplate	20,898.9	
	Output at Irradiance Levels	20,690.0	-1.0%
	Output at Cell Temperature Derate	20,208.8	-2.3%
	Output After Mismatch	20,196.8	-0.1%
	Optimal DC Output	20,196.8	0.0%
	Constrained DC Output	17,937.0	-11.2%
	Inverter Output	17,304.3	-3.5%
	Energy to Grid	16,789.9	-3.0%
Temperature Metrics			
	Avg. Operating Ambient Temp		16.2 °C
	Avg. Operating Cell Temp		23.7 °C
Simulation Metrics			
	Operating Hours		4668
	Solved Hours		4668

Appendices

Appendix A

<https://www.viridian.org/residential-programs/net-zero/resources/>

Net-Zero Resources

Certification

Net-Zero Ready: Meet all design, construction, and diagnostic testing criteria

Net-Zero Certified: 1 year of online energy tracking with neutral or positive bills

> Energy Performance

- > Net Zero Energy (site energy), HERs Index: ≤ 10
- > Minimum HERs Index prior to renewables: 50

> Diagnostic Testing

- > Infiltration target: 1.5 ACH50
- > Duct leakage: $\leq 2\%$ leakage to the outside, 10 system airflow capacity leakage

> Envelope

- > Meet or exceed 2012 IECC criteria including RESNET Grade I installation
- > Windows
 - > U Value: ≤ 30
 - > SHGC: ≤ 0.27
 - > High gain windows for south exposure

> HVAC/Ductwork

- > Manual J, D, and S
- > All ductwork located within the thermal envelope, mastic
- > Commissioning: Ventilation and HVAC (system airflow, refrigerant charge, room- room pressure ± 3 PA)

> Ventilation

- > Required: 62.2-2010

> Water Heating

- > WaterSense Indoor Criteria

> Lights/Appliances

- > 75% CFL and/or LED
- > Energy Star Appliances

> Renewables

- > Photovoltaic Array, Solar Thermal, and/or Wind Turbine(s)

Appendix B

IECC 2015 (Virginia Energy Conservation Code)

- R405.5.2 Residence Energy Model Specifications

TABLE R405.5.2(1)		
SPECIFICATIONS FOR THE STANDARD REFERENCE AND PROPOSED DESIGNS		
BUILDING COMPONENT	STANDARD REFERENCE DESIGN	PROPOSED DESIGN
Above-grade walls	Type: mass wall if the proposed wall is mass; otherwise wood frame. Gross area: same as proposed <i>U</i> -factor: from Table R402.1.3 Solar absorptance = 0.75 Remittance = 0.90	As proposed As proposed As proposed As proposed As proposed
Basement and crawl space walls	Type: same as proposed Gross area: same as proposed <i>U</i> -factor: from Table R402.1.3 , with the insulation layer on the interior side of walls.	As proposed As proposed As proposed
Above-grade floors	Type: wood frame Gross area: same as proposed <i>U</i> -factor: from Table R402.1.3	As proposed As proposed As proposed
Ceilings	Type: wood frame Gross area: same as proposed <i>U</i> -factor: from Table R402.1.3	As proposed As proposed As proposed
Roofs	Type: composition shingle on wood sheathing Gross area: same as proposed Solar absorptance = 0.75 Emittance = 0.90	As proposed As proposed As proposed As proposed
Attics	Type: vented with aperture = 1 ft ² per 300 ft ² ceiling area	As proposed
Foundations	Type: same as proposed foundation wall area above and below grade and soil characteristics: same as proposed.	As proposed As proposed
Doors	Area: 40 ft ² Orientation: North <i>U</i> -factor: same as fenestration from Table R402.1.3 .	As proposed As proposed As proposed
Glazing ^a	Total area ^b = (a) The proposed glazing area; where proposed glazing area is less than 15% of the conditioned floor area. (b) 15% of the conditioned floor area; where the proposed glazing area is 15% or more of the conditioned floor area.	As proposed
	Orientation: equally distributed to four cardinal compass orientations (N, E, S & W).	As proposed
	<i>U</i> -factor: from Table R402.1.3	As proposed
	SHGC: From Table R402.1.1 except that for climates with no requirement (NR) SHGC = 0.40 shall be used. Interior shade fraction: 0.92-(0.21 × SHGC for the standard reference design) External shading: none	As proposed 0.92-(0.21 × SHGC as proposed) As proposed
Skylights	None	As proposed
Thermally isolated sunrooms	None	As proposed

TABLE R405.5.2(1)—continued

SPECIFICATIONS FOR THE STANDARD REFERENCE AND PROPOSED DESIGNS

BUILDING COMPONENT	STANDARD REFERENCE DESIGN	PROPOSED DESIGN
Air exchange rate	Air leakage rate of 5 air changes per hour in Climate Zones 1 and 2, and 3 air changes per hour in Climate Zones 3 through 8 at a pressure of 0.2 inches w.g (50 Pa). The mechanical ventilation rate shall be in addition to the air leakage rate and the same as in the proposed design, but no greater than $0.01 \times CFA + 7.5 \times (N_{br} + 1)$ where: CFA = conditioned floor area N_{br} = number of bedrooms Energy recovery shall not be assumed for mechanical ventilation.	For residences that are not tested, the same air leakage rate as the standard reference design. For tested residences, the measured air exchange rate ^e . The mechanical ventilation rate ^d shall be in addition to the air leakage rate and shall be as proposed.
Mechanical ventilation	None, except where mechanical ventilation is specified by the proposed design, in which case: Annual vent fan energy use: $kWh/yr = 0.03942 \times CFA + 29.565 \times (N_{br} + 1)$ where: CFA = conditioned floor area N_{br} = number of bedrooms	As proposed
Internal gains	$IGain = 17,900 + 23.8 \times CFA + 4104 \times N_{br}$ (Btu/day per dwelling unit)	Same as standard reference design.
Internal mass	An internal mass for furniture and contents of 8 pounds per square foot of floor area.	Same as standard reference design, plus any additional mass specifically designed as a thermal storage element ^e but not integral to the building envelope or structure.
Structural mass	For masonry floor slabs, 80% of floor area covered by R-2 carpet and pad, and 20% of floor directly exposed to room air. For masonry basement walls, as proposed, but with insulation required by Table R402.1.3 located on the interior side of the walls For other walls, for ceilings, floors, and interior walls, wood frame construction	As proposed As proposed As proposed
Heating systems ^{f, g}	As proposed for other than electric heating without a heat pump. Where the proposed design utilizes electric heating without a heat pump the standard reference design shall be an air source heat pump meeting the requirements of Section R403 of the IECC—Commercial Provisions. Capacity: sized in accordance with Section R403.6	As proposed
Cooling systems ^{f, h}	As proposed Capacity: sized in accordance with Section R403.6 .	As proposed
Service water Heating ^{f, g, h, i}	As proposed Use: same as proposed design	As proposed $gal/day = 30 + (10 \times N_{br})$
Thermal distribution systems		Thermal distribution system efficiency shall be as tested or as specified in Table R405.5.2(2) if not tested. Duct insulation shall be as proposed.
Thermostat	Type: Manual, cooling temperature setpoint = 75°F; Heating temperature setpoint = 72°F	Same as a standard reference

Appendix C

Proposed HVAC Detail used in energy model:

WATER SOURCE HEAT PUMP SCHEDULE																								
BASIS OF DESIGN			SUPPLY FAN				COOLING			HEAT PUMP			WATER SOURCE HEAT PUMP CONDENSER					ELECTRICAL			ANTI-FREEZE	NOTES		
SYMBOL	MFR	MODEL	UNIT TYPE	TOTAL CFM	MIN OSA CFM	ESP (IN H2O)	NOM TONS	TOTAL CAP (MBH)	SENS CAP (MBH)	HTG (MBH)	WATER FLOW (GPM)	MAX PD (FT H2O)	PIPE SIZE	CLG EWT	HTG EWT	EER	COP	VOLTS	PH	RLA	FLA	MCA	%	
WSHP-1	DAIKIN	WSSV99	VERT DUCTED	1000	50	0.7	2.5	32.1	22.9	21.4	1.5	2.29	3/4"	77	32	26.1	4.1	230	1	12.8	5	21.0	20% PROPYLENE GLYCOL	1-4
WSHP-2	DAIKIN	WSSV92	VERT DUCTED	400	50	0.7	1.0	13.7	9.3	10	1.3	0.64	1/2"	77	32	18.1	3.5	230	1	4.7	6.9	8.8	20% PROPYLENE GLYCOL	1-4
WSHP-3	DAIKIN	WSSV99	VERT DUCTED	1000	126	0.7	2.5	32.0	22.9	21.6	1.5	2.29	3/4"	77	32	26.1	4.1	230	1	12.8	5	21.0	20% PROPYLENE GLYCOL	1-4

NOTES:
 1. PROVIDE WITH UNIT MOUNTED PROGRAMMABLE THERMOSTAT. ADA UNITS WILL REQUIRE REMOTE THERMOSTATS AT ADA MOUNTING HEIGHTS.
 2. PROVIDE SELF-BALANCING HOSE KIT WITH MOTORIZED CONTROL VALVE.
 3. PROVIDE WITH DISCONNECT SWITCH.
 4. PROVIDE WITH SINGLE POINT POWER CONNECTION.

Table 27: Standard unit without options

Unit Size	Power	Compressor		Fan Motor FLA	Total Unit FLA	Minimum Voltage	Minimum Circuit Amps	Maximum Fuse or HACR Breaker Size
	Voltage/Hz/Phase	RLA	LRA					
007	115/60/1	6.1	29.0	1.8	7.9	104	9.4	15
	208-230/60/1	3.0	15.0	0.9	3.9	197	4.7	15
	265/60/1	2.7	11.0	0.8	3.5	239	4.1	15
009	115/60/1	8.0	50.0	1.8	9.8	104	11.8	15
	208-230/60/1	3.7	22.0	0.9	4.6	197	5.6	15
	265/60/1	3.5	22.0	0.8	4.3	239	5.1	15
012	115/60/1	9.5	50.0	1.8	11.3	104	13.6	20
	208-230/60/1	4.7	25.0	0.9	5.6	197	6.8	15
	265/60/1	4.2	22.0	0.8	5.0	239	6.0	15
015	208-230/60/1	5.6	29.0	3.0	8.6	197	10.0	15
	265/60/1	5.0	28.0	2.6	7.6	239	8.9	15
019	208-230/60/1	6.6	33.0	3.0	9.6	197	11.3	15
	265/60/1	5.6	28.0	2.6	8.2	239	9.6	15
024	208-230/60/1	13.5	58.3	3.0	16.5	197	19.9	30
	265/60/1	9.0	54.0	2.6	11.6	239	13.9	20
	208-230/60/3	7.1	55.4	3.0	10.1	197	11.9	15
030	*460/60/3	3.5	28.0	2.6	6.1	414	7.0	15
	208-230/60/1	12.8	64.0	5.0	17.8	197	21.0	30
	265/60/1	10.9	60.0	4.1	15.0	239	17.7	25
	208-230/60/3	8.3	58.0	5.0	13.3	197	15.4	20
	*460/60/3	5.1	28.0	4.1	9.2	414	10.5	15
	208-230/60/1	14.1	77.0	5.0	19.1	197	22.6	35

FAN SCHEDULE

SYMBOL	AREA SERVED	BASIS OF DESIGN		TYPE	DRIVE	AIR FLOW (CFM)	ESP (IN H2O)	SOUND (SONES)	ELECTRICAL			MAX WT (LBS)	NOTES
		MFR	MODEL						VOLTS	PH	AMPS		
EF-1	BATHROOM	BROAN	FLEX DC - AE50110DC	INLINE FAN	DIRECT	50	0.10	0.3	120	1	0.33	8.5	1,2,3

NOTES:
 1. PROVIDE WITH STANDARD DISCONNECT.
 2. PROVIDE WITH BACKDRAFT DAMPER.
 3. PROVIDE WITH RADIATION DAMPER.

ENERGY RECOVERY VENTILATOR SCHEDULE



SYMBOL	RECOVERY PERFORMANCE			BASIS OF DESIGN	MAX. WT. (LBS)	ELECTRICAL				REMARKS
	NET AIRFLOW (CFM)	TEMP EFFICIENCY (%)	ESP IN. W.G.			VOLT/PH	HP	WATTS	FLA	
ERV-1	90.0	76.0	0.50	RENEWAIRE BR130	60	120/1	0.1	121	1.3	1-7
ERV-2	60.0	77.0	0.30	RENEWAIRE BR71	50	120/1	0.08	94	1	1-7
ERV-3	120.0	72.0	0.35	RENEWAIRE BR130	60	120/1	0.1	121	1.3	1-7

NOTES:
 1. PROVIDE WITH MERV 13 FILTER - RA AIRSTREAM
 2. PROVIDE WITH BACKDRAFT DAMPER
 3. PROVIDE AUTOMATIC BALANCING DAMPER
 4. PROVIDE LOUVERED WALL VENT 6" - WHITE
 5. PROVIDE EXTERIOR THRU-THE WALL INSTALLATION KIT
 6. PROVIDE MERV 13 FILTER - OA AIRSTREAM
 7. PROVIDE DUCT COLLAR KIT.

Appendix D

Selected PV Panel Specification

MODULE SPECIFICATIONS	
60X SUNPOWER X22-370	
STC RATING	370W
Vmp	59,1V
Imp	6.26A
Voc	69.5V









SunPower X-Series: X22-370

SunPower® Residential DC Panel

SunPower X-Series panels combine the top efficiency, durability and warranty available in the market today, resulting in more long-term energy and savings. ^{1,2}

 **Maximum Power. Minimalist Design.**
Industry-leading efficiency means more power and savings per available space. With fewer panels required, less is truly more.



 **Highest Lifetime Energy and Savings**
Designed to deliver 60% more energy in the same space over 25 years in real-world conditions like partial shade and high temperatures. ²



Fundamentally Different. And Better.

The SunPower Maxeon® Solar Cell

- Enables highest efficiency panels available ²
- Unmatched reliability ³
- Patented solid metal foundation prevents breakage and corrosion



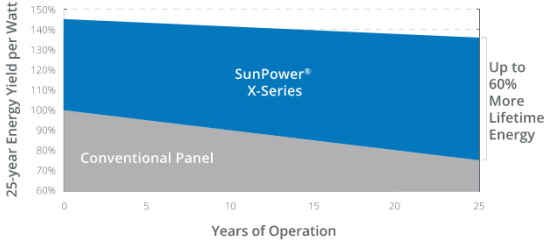

As Sustainable As Its Energy

- Ranked #1 in Silicon Valley Toxics Coalition 2015 Solar Scorecard ⁴
- First solar panels to achieve Cradle to Cradle Certified™ Silver recognition ⁵
- Contributes to more LEED categories than conventional panels ⁶



Up to 60% More Lifetime Energy

 **Best Reliability, Best Warranty**

With more than 25 million panels deployed around the world, SunPower technology is proven to last. That's why we stand behind our panel with the industry's best 25-year Combined Power and Product Warranty, including the highest Power Warranty in solar.



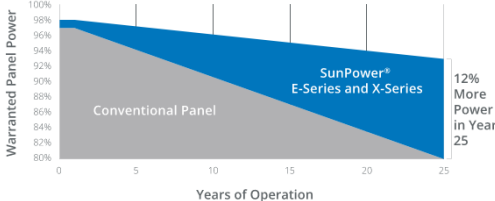

12% More Power in Year 25

X-Series: X22-370 SunPower® Residential DC Panel

Electrical Data	
SPR-X22-370	
Nominal Power (P _{nom}) ⁷	370 W
Power Tolerance	+5/0%
Panel Efficiency	22.7%
Rated Voltage (V _{mpp})	59.1 V
Rated Current (I _{mpp})	6.26 A
Open-Circuit Voltage (V _{oc})	69.5 V
Short-Circuit Current (I _{sc})	6.66 A
Max. System Voltage	600 V UL & 1000 V IEC
Maximum Series Fuse	15 A
Power Temp Coef.	-0.29% / °C
Voltage Temp Coef.	-167.4 mV / °C
Current Temp Coef.	2.9 mA / °C

Operating Condition And Mechanical Data	
Temperature	-40° F to +185° F (-40° C to +85° C)
Impact Resistance	1 inch (25 mm) diameter hail at 52 mph (23 m/s)
Appearance	Class A+
Solar Cells	96 Monocrystalline Moxeon Gen III
Tempered Glass	High-transmission tempered anti-reflective
Junction Box	IP-65, MC4 compatible
Weight	41 lbs (18.6 kg)
Max. Load	G5 Frame: Wind: 62 psf, 3000 Pa front & back Snow: 125 psf, 6000 Pa front
	G3 Frame: Wind: 50 psf, 2400 Pa front & back Snow: 112 psf, 5400 Pa front
Frame	Class 1 black anodized (highest AAMA rating)

Tests And Certifications	
Standard Tests ⁸	UL1703 (Type 2 Fire Rating), IEC 61215, IEC 61730
Quality Management Certs	ISO 9001:2015, ISO 14001:2015
EHS Compliance	RoHS, OHSAS 18001:2007, lead free, Recycle Scheme, REACH SVHC-163
Sustainability	Cradle to Cradle Certified™ Silver. "Declare." listed.
Ammonia Test	IEC 62716
Desert Test	10.1109/PVSC.2013.6744437
Salt Spray Test	IEC 61701 (maximum severity)
PID Test	1000V: IEC 62804, PVEL 600 hr duration
Available Listings	UL, TUV, MCS, FSEC, CEC

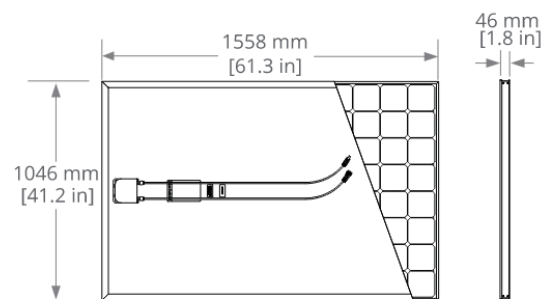

G5 FRAME PROFILE
InvisiMount™ Compatible

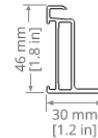

G3 FRAME PROFILE
Not InvisiMount Compatible

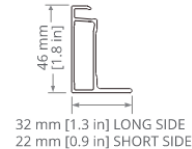

G5 frames have no mounting holes. Please read the safety and installation guide.

- 1 SunPower 360 W compared to a Conventional Panel on same-sized arrays (260 W, 16% efficient, approx. 1.6 m²), 4% more energy per watt (based on PVsyst pan files), 0.75%/yr slower degradation (Campeau, Z. et al. "SunPower Module Degradation Rate," SunPower white paper, 2013).
- 2 Based on search of datasheet values from websites of top 10 manufacturers per IHS, as of January 2017.
- 3 #1 rank in "Fraunhofer PV Durability Initiative for Solar Modules: Part 3". PVTech Power Magazine, 2015. Campeau, Z. et al. "SunPower Module Degradation Rate," SunPower white paper, 2013.
- 4 SunPower is rated #1 on Silicon Valley Toxics Coalition's Solar Scorecard.
- 5 Cradle to Cradle Certified is a multi-attribute certification program that assesses products and materials for safety to human and environmental health, design for future use cycles, and sustainable manufacturing.
- 6 X-Series and E-Series panels additionally contribute to LEED Materials and Resources credit categories.
- 7 Standard Test Conditions (1000 W/m² irradiance, AM 1.5, 25° C). NREL calibration Standard: SOMS current, LACCS FF and Voltage.
- 8 Type 2 fire rating per UL1703:2013, Class C fire rating per UL1703:2002.

See www.sunpower.com/company for more reference information.
For more details, see extended datasheet: www.sunpower.com/solar-resources.
Specifications included in this datasheet are subject to change without notice.

©2018 SunPower Corporation. All rights reserved. SUNPOWER, the SUNPOWER logo, MAXEON and InvisiMount are trademarks or registered trademarks of SunPower Corporation.

SUNPOWER®

SECTION 01 9113 - GENERAL COMMISSIONING REQUIREMENTS

PART 1 - GENERAL

1.1 SUMMARY

- A. Work Included:
 - 1. Scope of systems and equipment to be commissioned.
 - 2. Commissioning duties and procedures at the site.

1.2 RELATED SECTIONS

- A. Division 01, General Requirements applies to this Section.
- B. Contents of Division 22, 23, and 26 apply to this Section.
- C. In addition, reference the following:
 - 1. 22 08 00, Commissioning of Plumbing
 - 2. 23 08 00, Commissioning of HVAC
 - 3. 26 08 00, Commissioning of Electrical

1.3 REFERENCES AND STANDARDS

- A. References and Standards as required by:
 - 1. Division 01, General Requirements.
 - 2. 22 08 00, Commissioning of Plumbing
 - 3. 23 08 00, Commissioning of HVAC
 - 4. 26 08 00, Commissioning of Electrical
- B. In addition, meet the following:
 - 1. Current edition of the ASHRAE Guideline 0, The Commissioning Process.

1.4 SUBMITTALS

- A. Submittals as required by:
 - 1. Division 01, General Requirements.
 - 2. 22 08 00, Commissioning of Plumbing
 - 3. 23 08 00, Commissioning of HVAC
 - 4. 26 08 00, Commissioning of Electrical
- B. In addition, provide:
 - 1. Use the following procedure to ensure quick and effective turnaround of submittals for systems to be commissioned.
 - a. The Architect forwards one set of submittals for systems to be commissioned to the Commissioning Authority at the same time as the design team.
 - b. The Commissioning Authority forwards comments to the design team for consideration in their submittal response.
 - c. The design team sends a consolidated response to the submittals and copies the Commissioning Authority.

1.5 QUALITY ASSURANCE

- A. Quality assurance as required by:
 - 1. Division 01, General Requirements.
 - 2. 22 08 00, Commissioning of Plumbing
 - 3. 23 08 00, Commissioning of HVAC
 - 4. 26 08 00, Commissioning of Electrical

1.6 WARRANTY

- A. Warranty of materials and workmanship as required by Division 01, General Requirements.
 - 1. Division 01, General Requirements.
 - 2. 22 08 00, Commissioning of Plumbing
 - 3. 23 08 00, Commissioning of HVAC
 - 4. 26 08 00, Commissioning of Electrical

1.7 DEFINITIONS

- A. Commissioning Authority: The Commissioning Authority is the person or entity referred to throughout the Contract Documents as if singular in number who works with the Owner's Authorized Representative under a separate Contract.
- B. Commissioning:
 - 1. Commissioning is a process for achieving, verifying, and documenting that performance of a building and its various energy consuming systems meets the Design Engineer's design intent and the Owner's operational needs.
 - 2. Commissioning includes tests for the operation of equipment and building systems to ensure that they operate as designed by the Design Engineer, and meet the needs of the building throughout the entire range of operating conditions.
 - 3. Commissioning is a cooperative effort that requires participation by the Owner's Authorized Representative, General Contractor, system and equipment installers, building automation system installer, Testing and Balancing Agency, equipment manufacturers' representatives, Architect, Architect's design engineers, and Commissioning Authority.
- C. Owner's Project Requirements (OPR): Document that details the functional requirements and expectations of how the building will be used and operated. This may include project location, goals, cost considerations, equipment manufacturers, and environmental control requirements.
- D. Basis of Design (BoD): A document that records concepts, calculations, decisions, and product selections used to meet the OPR and to satisfy applicable regulatory requirements, standards, and guidelines.
- E. Commissioning Procedures:
 - 1. Inspection and testing procedures that are written by the Commissioning Authority for equipment and systems within the scope of commissioning.
 - 2. Inspection checklists typically address items of installation compliance with design intent and approved submittals.

3. Functional performance test procedures typically address all sequences for normal and emergency equipment and system operation. These procedures consist of a mix of One-Time Tests and Continuous Measurement.
 4. One-Time Tests: Functional performance tests of equipment and systems that are performed by forcing specific conditions that are intended to trigger specific responses, per the design intent.
- F. Continuous Measurements:
1. Functional performance tests of equipment and systems that are performed by observing parameters of normal operation over an extended period. This is typically accomplished by means of the BAS trend logging capabilities, by monitoring with stand-alone data logging equipment, or by some combination of both.
 2. Temperature conditions in occupied spaces, control stability, and lighting levels in areas with daylighting controls are three typical subjects of continuous measurement.
- G. Commissioning Plan: The document, provided by the Commissioning Authority, that states the required tests for all equipment and systems within the scope of commissioning.
- H. Commissioning Meetings: Issues related to commissioning will be discussed as required during regularly scheduled progress meetings.

1.8 PERFORMANCE REQUIREMENTS

- A. Testing, inspecting and performance monitoring tasks specified in this Section and in Sections 22 08 00, 23 08 00, and 26 08 00 are the responsibility of the Commissioning Authority, unless specifically indicated otherwise, and not part of the General Construction Contract. These tasks are included in these Sections for the Contractor's information, so the Contractor can understand the standards of system performance that are required and more effectively coordinate with the process of commissioning.
- B. The Commissioning Authority will verify for the Owner's Authorized Representative that commissioned mechanical, plumbing, electrical, and controls system function interactively and in compliance with the Project design intent, and to facilitate orderly and efficient transfer of building operating systems to the Owner.
- C. Commissioning does not relieve the Contractor of Contract obligations.

1.9 EQUIPMENT AND SYSTEMS TO BE COMMISSIONED

- A. Systems:
1. HVAC Equipment
 2. HVAC Controls.
 3. Domestic Hot Water Equipment
 4. Automatic Lighting Controls (LCP, Daylighting, Occupancy Sensors)

1.10 COMMISSIONING DUTIES

- A. Duties of Owner: Provide the OPR to the Architect/Engineer and Commissioning Authority prior to design development.
- B. Duties of Architect:

1. Attend commissioning portion of Progress Meetings as necessary, minimum two meetings.
 2. Lead the design team in assisting the resolution of deficiencies.
- C. Duties of Architect's Mechanical Engineer:
1. Attend commissioning portion of Progress Meetings as necessary, minimum two meetings.
 2. At the request of either the Owner's Authorized Representative or the Commissioning Authority, review Commissioning Procedures and submit comments to Owner's Authorized Representative.
 3. Develop and provide the Basis of Design to Owner and Commissioning Authority prior to 50 percent CD.
 4. Assist in resolution of problems and deficiencies that are discovered during commissioning.
 5. Participate and respond to commissioning related issues by using the Commissioning Authority's web based commissioning software Facility Grid.
- D. Duties of Architect's Electrical Engineer:
1. Attend commissioning portion of Project Meetings as necessary.
 2. At request of either the Owner's Authorized Representative or the Commissioning Authority, review Commissioning Procedures and submit comments to Owner's Authorized Representative.
 3. Develop and provide the Basis of Design to Owner and Commissioning Authority prior to 50 percent CD.
 4. Assist in resolution of problems and deficiencies that are discovered during commissioning.
 5. Participate and respond to commissioning related issues by using the Commissioning Authority's web based commissioning software Facility Grid.
- E. Duties of Commissioning Authority:
1. Attend commissioning portion of Project Meetings as necessary, minimum two meetings.
 2. Provide plan to Owner's Authorized Representative for review and comment.
 3. Utilize web based Commissioning software to manage all commissioning related checklists, tests, issues, and observation reports.
 4. Prepare commissioning procedures for each commissioned system based on actual system configuration.
 5. Commissioning Procedures written by Commissioning Authority will include, in field data collection format, the detailed test procedures, test conditions, and criteria for acceptance of test results.
 6. Submit any commissioning procedures that are written by Commissioning Authority to the Owner's Authorized Representative for review and approval at least 1 week prior to scheduled field testing.
 7. Provide personnel experienced in technical aspects of each system to be commissioned for execution of tests.
 8. BAS Sequence Demonstration:
 - a. Witness the Control Contractor's demonstration of their sequence tests.
 - b. If any of the demonstrated sequences fails to operate per the controls submittal, witness the repeat demonstration after corrective action has been taken.
 9. Execute the Commissioning Procedures.

10. Prepare and submit Observation Reports and Deficiency Reports as required, but within 3 days of noting any deficiency.
 11. Submit to Owner's Authorized Representative a weekly written report of commissioning progress, unresolved deficiencies, and projected inspection, and test schedule during field testing.
 12. Take the lead in timely evaluation of deficiencies, and advise Owner's Authorized Representative on resolution.
 13. Assist in resolving commissioned system disputes by performing research to determine the scope of the dispute, and informing the involved parties on possible solutions to disputes.
 14. During the systems warranty period(s) CxA to retest any systems that had their full testing deferred during the initial functional testing due to the lack of peak season conditions. This testing must ensure that all system sequences of operations and capacity have been verified.
 15. Prepare a Commissioning Report that includes a summary of overall commissioning process, including deficiencies found, deficiency corrections, unresolved deficiencies, approved equipment and systems, discrepancies between final design intent and as-built systems, completed commissioning checklists, test documentation, and other commissioning documentation.
- F. Duties of General Contractor:
1. Attend commissioning portion of Project Meetings as necessary, minimum four meetings.
 2. Participate and respond to commissioning related issues by using the Commissioning Authority's web based commissioning software Facility Grid.
 3. Coordinate and direct system installers in executing their commissioning tasks.
 4. Direct subcontractors to participate and respond to commissioning related issues by using the Commissioning Authority's web based commissioning software Facility Grid. A desktop, laptop, tablet or iPad will be required.
 5. Coordinate with Commissioning Authority on integration of construction and commissioning schedules.
 6. Oversee and perform documentation requirements for all Pre-Functional Checklists.
 7. Notify Commissioning Authority when all the following has been achieved. It is permissible, with prior approval by Commissioning Authority, to provide notification for individual systems as the following are all completed for each system.
 - a. All controls point-to-point and sequence checkout is complete.
 - b. All test and balancing is complete.
 - c. Normal equipment schedules have been activated.
 - d. All control overrides and temporary valves have been returned to normal automatic control.
 - e. All manual isolation valves have been left open.
 - f. Piping and duct systems have been cleaned and tested.
 - g. Heating water system is fully operational under normal automatic operation.
 - h. Luminaires are installed with operational daylighting controls and occupancy sensors.
 - i. Distribution boards, including overcurrent devices, containing breakers over 600 amps, are installed.
 - j. Building inspector acceptance of emergency lighting system following their site inspection.
 8. Provide all startup, flushing, pressure testing, etc results/reports for commissioned systems.

- G. Duties of Installer's and Manufacturer's Representatives:
1. Attend commissioning portion of Project Meetings as necessary, minimum two meetings.
 2. Participate and respond to commissioning related issues by using the Commissioning Authority's web based commissioning software Facility Grid.
 3. Within three months of the award of the Contract, as part of the required submittals for the contract, Contractor submits manufacturer's startup and installation procedures as well as controls point-to-point and sequence checkout and provides in checkset format for each piece of equipment and controls.
 4. Demonstrate proper system operation in the presence of the Commissioning Authority.
 5. Commissioning does not relieve installers from obligations to complete Work as required by Contract Documents.
- H. Duties of BAS Installer:
1. Attend commissioning portion of project meetings as necessary, minimum two meetings.
 2. Participate and respond to commissioning related issues by using the Commissioning Authority's web based commissioning software Facility Grid.
 3. Review and approve Commissioning Procedures as relevant to controls work.
 4. Point-to-Point Checkout:
 - a. Perform point-to-point checkout and calibration of all energy management system points.
 - b. Document checkout and calibration on forms as approved by mechanical designer, and/or Commissioning Authority.
 - c. Submit three copies of the completed point-to-point checkout forms to the Owner's Authorized Representative within five working days of completion of field checkout. Distribute copies to the Commissioning Authority and the designer.
 5. Control Sequence Testing:
 - a. Prepare control sequence test procedure forms to a degree of rigor comparable to the Commissioning Authority's Commissioning Procedures.
 - b. Submit test procedure forms to the Commissioning Authority for approval at least two weeks prior to intended sequence testing. At the contractor's option, it is acceptable to use the Commissioning Authority's Commissioning Procedures, substituting one-time tests for continuous measurement wherever applicable. However, it is still necessary to submit any edited Commissioning Authority Commissioning Procedures as least two weeks prior to intended sequence testing.
 - c. Submit the completed sequence testing forms to the Owner's Authorized Representative. The Owner's Authorized Representative distributes copies to the Commissioning Authority and the designer.
 6. Submit to Commissioning Authority, prior to Sequence Demonstration, two copies of installed control Drawings, sequence narratives, control wiring diagrams, and program code or block diagrams.
 7. Sequence Demonstration:
 - a. After completing and documenting all required sequence tests with own staff, demonstrate sequence tests to the Commissioning Authority. Demonstration is to be performed by the BAS installer's programmer who programmed the control system for this specific project.
 - b. If any of the demonstrated sequences fails to operate per the controls submittal, take corrective action and demonstrate the failed sequence tests to the Commissioning Authority a second time.

- c. If the Control Contractor fails to demonstrate proper sequence operation in any of the second round of sequence tests, the Commissioning Authority's costs for witnessing all further demonstration of that sequence may be assigned to the Control Contractor by the Owner as a deduct to their contracted price. The Control Contractor will not be responsible for costs related to failure due to design or to other factors beyond their control, though it is expected to call any design concerns (and other factors beyond their control that might cause failure) to the attention of the Commissioning Authority and the Owner's Authorized Representative.
 8. Assist Commissioning Authority with programming of the energy management system for trend logs to support functional performance testing during field testing.
 9. Assist Commissioning Authority with execution of the Commissioning Procedures. Commissioning Authority will present test schedule at Progress Meeting at least one week ahead of scheduled tests.
 10. The Commissioning Authority, acting with Owner authority, may request the Control Contractor to assist with or perform minor loop tuning adjustments, set point and schedule changes, and other similar minor field corrections.
 11. Recommended changes to the controls sequences, program code, and recommendations for additional points must go through the Owner's Authorized Representative and the designer. The designer is the final authority on all recommended sequence changes, and will submit such changes to the Owner's Authorized Representative for implementation.
 12. Submit to Owner's Authorized Representative, at least two weeks prior to Final Completion, two copies of as-built version of points list, including I/O and virtual points, controls Drawings, program printout, and sequence narratives.
 13. Participate in resolution of problems and deficiencies that are discovered during commissioning.
- I. Duties of Balancer:
1. Attend commissioning portion of Project Meetings as necessary, minimum two meetings.
 2. Participate in resolution of problems and deficiencies that are discovered during commissioning.
 3. Assist Commissioning Authority with execution of commissioning procedures.
 4. Demonstrate accuracy of final balance report in the presence of the Commissioning Authority. This will be a 10 percent spot check.

PART 2 - PRODUCTS (NOT USED)

PART 3 - EXECUTION

3.1 COMMISSIONING PROCEDURES AT THE SITE

- A. Testing Techniques:
1. Each testing procedure may use a variety of techniques. Generally it is preferred to observe new and existing equipment and systems during normal operation.
 2. When functional and emergency modes of operation occur rarely or seasonally, if possible, simulate the conditions that trigger these operational modes.
 3. Simulation of conditions may involve changing set points, changing schedules, simulating pneumatic system pressures or energy management system voltages and currents, disconnecting power, jumpering contacts, or other such procedures.
 4. Whenever temporary adjustments are made, restore the system to its original condition once tests are completed.

5. When testing requires observing equipment operation over an extended period, use the building energy management system's trend logging capabilities or independent monitoring equipment.
 6. Do not use the building automation system trend logging in the commissioning process prior to point-to-point checkout by Controls Contractor and approval of point-to-point checkout by Commissioning Authority.
 7. Measurement of room lighting levels during evening hours with only artificial lighting, during mid-morning, around noon and mid-afternoon with only natural lighting and with both natural and artificial lighting. Repeat same measurements following calibration of room daylighting sensor.
- B. Commissioning Documentation:
1. The Contractors are required to perform startup and checkout of their systems (prefunctional testing) and document the results in Facility Grid. The Commissioning Authority will provide electronic forms that may be used by the Contractors. The Contractors may use their own forms if they contain all the required information on the Commissioning Authority's forms, but prior approval must be obtained.
 - a. Where numeric data is required, a narrative entry or simple check-off is not acceptable.
 - b. Annotate trend logs and monitored data as necessary to clarify meaning, and attach to relevant test reports.
 - c. Do not attach irrelevant data to test reports.
 2. The Contractor sends the startup and checkout forms to the Commissioning Authority when they are complete and functional. The Contractor sends a "Certificate of Readiness" with the forms which will signal that functional testing can begin.
 3. The technician who performed the pretesting and checkout of the system completes the Pre-Functional Checklists using the web based commissioning software Facility Grid.
 4. E-mail an "issues log" weekly to inform the design and construction team of issues that need resolution. The "issues log" will open and close items as they are discovered and resolved until all items are closed.
 5. The Commissioning Authority will assemble all the information from the Commissioning Plan (test forms, trend logs, issues log, and basis of design) into a final Commissioning Report.
- C. Coordination of Commissioning and Equipment Startup: Do not initiate functional performance testing for equipment or systems in advance of their startup and checkout by affected equipment or system installers and manufacturers' representatives.
- D. Test Acceptance Criteria:
1. Acceptance Criteria are the test results that are required before the mode of performance or inspection item in question will be considered acceptable.
 2. Any procedures in Specification Sections 22 08 00, 23 08 00, or 26 08 00 that begin with "Verify that..." have an implied acceptance criterion that the sequence as stated is proven to occur and is documented with visual observation notes, measurements, trend logs, and/or monitored data.
 3. Acceptance criteria for other functional modes and checklist items are as stated in each section of the Commissioning Plan.
 4. Input will be sought when necessary from the Architect's Engineer to determine if test results indicate compliance with Design Intent.

5. The Commissioning Authority will recommend acceptance or rejection of commissioned system work based on test results.
- E. Resolution of Deficiencies:
1. Adjust, repair, or replace defective equipment and systems to meet Commissioning Procedure Acceptance Criteria as directed by Owner's Authorized Representative.
 2. Inform the Owner's Authorized Representative and Commissioning Authority of the date for completion of corrective activities.
 3. If the date for completion of corrective work passes without resolution of deficiencies, Owner's Authorized Representative reserves the right to obtain supplementary services and equipment to correct the problem as indicated in General Conditions.
- F. Rechecking and Retesting Charges:
1. In the event of a second failure of a specific commissioning procedure item or test, the responsible party may be assessed charges by Owner's Authorized Representative.
 2. Charges will be based on each party's actual expenses, including normal hourly billing rates for preparation, testing, and travel time, and materials, equipment rental, and travel expenses as applicable.
- G. Construction and Acceptance Milestones for Tasks Related to Commissioning:
1. Equipment, ductwork, and piping installation.
 2. Equipment startup.
 3. Pre-functional checklists.
 4. Substantial completion.
 5. Point-to-point checkout and sequence testing of controls.
 6. Test and balance.
 7. Commissioning field testing.
 8. Owner training.
 9. Occupant move-in.
 10. Final completion.
 11. Seasonal testing.
 12. Commissioning report submittal.

END OF SECTION

SECTION 019116 - HVAC COMMISSIONING PLAN

PART 1 - GENERAL

1.1 RELATED DOCUMENTS:

- A. Drawings and General Provisions of Contract, including General and Supplementary Conditions, Division I Specification sections, and all other sections of the specifications shall also apply to the extent required for proper performance of the Work of the section.

1.2 DESCRIPTION

- A. Commissioning is a quality-oriented process for achieving, verifying, and documenting that the performance of facilities, systems, and assemblies meet defined objectives and criteria. The commissioning process includes specific tasks to be conducted during construction to verify that construction is performed in accordance with contract requirements, equipment installations provide adequate service access, systems perform in accordance with design intent, and training meets the owner's requirements.
- B. The commissioning process does not take away from or reduce the responsibility of the system designers or installing contractors to provide a finished and fully functioning product.

1.3 COMMISSIONING TEAM

- A. Commissioning Team: The members of the commissioning team consist of:
 - 1. The County's representative (CR)
 - 2. The commissioning authority (CxA) – Third party or the Engineer of Record.
 - 3. The design engineers of record (AE)
 - 4. The general contractor (GC)
 - 5. The mechanical contractor (MC)
 - 6. The electrical contractor (EC)
 - 7. The testing and balancing contractor (TAB)
 - 8. The controls contractor (CC)
 - 9. The facility operating and maintenance staff
 - 10. Other installing subcontractors
 - 11. Equipment suppliers and manufacturers representatives
- B. The CxA directs and coordinates the project commissioning activities and reports to the owner. All team members work together to fulfill their contracted responsibilities and meet the objectives of the contract documents.

1.4 SCOPE

- A. This section provides the general requirements that apply to the implementation of the commissioning process. Specific components, assemblies, and systems commissioning requirements are per Division 23 and this Section.

- B. In general, the following components, assemblies, and systems will be commissioned:
 - 1. Existing air handling units on each floor that feed VAV's affected by the work.
 - 2. Air terminal units (VAV boxes) in each Phase of the work, and existing air terminal units affected by the work.
 - 3. New ductwork and ductwork insulation.
 - 4. Diffusers, registers and grilles
 - 5. Existing building automation system and control sequences of operation related to the air distribution system on each floor.
- C. Existing ATU's to remain that are not affected by the work will not be commissioned.

1.5 COORDINATION

- A. Project Commissioning Team: The members of the project commissioning team will consist of the commissioning authority and any support personnel, the construction manager, the County's facility staff or designee, the general contractor, subcontractors and/or vendors as required, and the architect/ engineer.
- B. Management: The CxA coordinates the commissioning activities through the construction manager. All members shall work together to fulfill their contracted responsibilities and meet the objectives of the contract documents.
- C. Scheduling: The CxA will provide sufficient information to the contractor for required commissioning activities. The contractor will integrate all commissioning activities into the overall project schedule. All parties will address scheduling problems and make necessary notifications in a timely manner in order to expedite the commissioning process.

1.6 PROCESS

- A. The following is a brief overview of the typical commissioning tasks during and after construction and the general order in which they occur.
 - 1. Commissioning during construction begins with an initial commissioning meeting conducted by the CxA where the commissioning process is reviewed with the project commissioning team members.
 - 2. Additional meetings will be required throughout construction, scheduled by the CxA, through the owner with necessary parties attending to plan, scope, coordinate, schedule future activities and resolve problems.
 - 3. Equipment documentation is submitted to the CxA, through the owner, during normal submittals, including detailed startup procedures.
 - 4. The pre-functional checklists are to be completed by the contractors throughout the construction installation and during the startup process.
 - 5. Pre-functional checklists and equipment startup must be completed before systems performance verification. Additionally, testing and balancing and automation system trending must be completed before HVAC systems performance verification can occur.
 - 6. The contractor ensures that the subcontractors' construction checklists are executed and documented and that startup and initial checkout are performed. The CA verifies that the TAB, construction checklists and startup were completed according to contract requirements.

7. The CxA develops and implements equipment and system performance verification procedures. The performance verification tests are executed by the contractor under the direction of the CxA with participation of the facility staff.
8. Deficiencies discerned during construction, start-up, or performance verification will be documented by the CxA. Rectification of deficiencies resides with the contractor or AE.
9. The CxA reviews the O&M documentation for completeness and pertinence; and participates in contractor's instructions and training of County's operating and maintenance personnel.

B. All equipment/systems:

1. This includes functional checklists completion, trends analysis and seasonal performance verification testing.

1.7 RESPONSIBILITIES

A. The general responsibilities of various parties in the commissioning process are provided herein; amplification of specific responsibilities are in Division 23.

B. All Parties

1. Follow the commissioning plan.
2. Attend initial commissioning meeting and additional meetings as necessary.

C. County's Representative (CR)

1. Facilitate the coordination of the commissioning work by the CxA, and, with the GC and CxA, insure that commissioning activities are being scheduled into the master schedule.
2. Review and approve the final Commissioning Plan.
3. Attend a commissioning scoping meeting and other commissioning team meetings.
4. Furnish a copy of all construction documents, addenda, change orders and approved submittals and shop drawings related to commissioned equipment to the CxA.
5. Review and approve the performance test procedures submitted by the CxA.
6. Observe and witness startup and performance testing of selected equipment.
7. Review commissioning progress and deficiency reports. Coordinate and enforce the resolution of cited non-compliance issues and deficiencies.
8. Sign-off (final approval) on individual commissioning tests as completed and passing.
9. Assign operation and maintenance personnel and schedule them to participate in commissioning team activities and contractor's instructions and training.
10. Assist the CxA as necessary in deferred performance verification and deficiency corrections required by the specifications.
11. Acknowledge completion of commissioning process and accept substantial completion.

D. Engineer of Record (AE)

1. Engineer: In addition to performing the normal construction contract administration functions, architect shall:
 - a. Attend initial commissioning meeting and selected commissioning team meetings.
 - b. Provide any design narrative documentation requested by the CxA.

- c. Coordinate with CR to assure that the CxA is:
 - 1) Provided copies of approved shop drawings as they are returned to the Contractor
 - 2) Notified of time, date, and place of all regularly scheduled progress meetings, and of any special meetings that may be called regarding commissioned systems.
 - 3) Copied on all correspondence pertinent to the commissioned systems including but not limited to minutes of progress meetings, responses to contractor requests for information, change order documentation.
 - d. Coordinate resolution of cited deficiencies.
2. Engineers: In addition to performing the normal construction contract administration functions of submittals review, site visits, O&M manuals and As-Built documents review, engineers shall:
- a. Attend initial commissioning meeting and other selected commissioning team meetings.
 - b. Provide any design narrative and sequences documentation requested by the CxA. Assist in clarifying the operation and control of commissioned equipment in areas where the specifications, control drawings, or equipment documentation is not sufficient for writing performance verification procedures.
 - c. Participate in the resolution of cited deficiencies.
 - d. Participate in training of County's operating and maintenance personnel, including providing systems design intent.
 - e. Witness performance verification of selected equipment and systems.
- E. Contractors: General contractor, subcontractors, and vendors shall assign representatives with expertise and authority to act on their behalf and schedule them to participate in and perform commissioning activities including, but not limited to, the following:
1. Facilitate the coordination of commissioning and incorporate commissioning activities into the project schedule.
 2. Provide detailed startup procedures for all commissioned equipment/systems.
 3. Include the cost of commissioning in the total contract price.
 4. Attend initial commissioning meeting and other selected commissioning team meetings.
 5. GC shall execute the commissioning responsibilities according to the contract documents and ensure that all subcontractors and vendors do likewise. Among the requirements:
 - a. The CxA is to be notified to witness construction milestones.
 - b. Pre-functional checklists are completed by contractors as work progresses.
 - c. Written responses are to be provided to deficiencies/issues resolution logs issued by the CxA; responses are to be returned to the CxA within 2-weeks of date of issue.
 - d. O&M manuals are to be submitted for review no later than 60 days after the last shop drawing/submittal has been approved.
 6. Provide the training of County personnel. Training plan shall be submitted for approval at least four weeks prior to first training session. Approved O&M manuals shall be employed in training.
 7. Provide equipment/systems performance verification under CxA direction, including for seasonal or deferred verification. The contractors shall provide all tools or the use of tools to start, check-out and test equipment and systems. Evaluate performance deficiencies and, in collaboration with entity responsible for system and equipment installation, recommend

corrective action.

F. Commissioning Authority (CxA)

1. Coordinates and directs the commissioning activities in a logical, sequential and efficient manner using consistent protocols and forms, centralized documentation, clear and regular communications and consultations with all necessary parties, frequently updated timelines and schedules and technical expertise.
2. Coordinate the commissioning work and, with the GC and owner/CM, help integrate commissioning activities into the master schedule.
3. Revise the Construction Phase Commissioning Plan as necessary.
4. Plan and conduct an initial commissioning meeting and other commissioning meetings as required.
5. Request and review additional information required to perform commissioning tasks, including O&M materials, contractor startup and checkout procedures.
6. Review AE approved contractor submittals applicable to systems being commissioned for compliance with commissioning needs.
7. Write and distribute construction pre-functional checklists. Monitor execution of checklists during construction and provide approval when warranted.
8. Perform site visits, as necessary, to observe component and system installations. Attend selected planning and job-site meetings to obtain information on construction progress. Review construction meeting minutes for revisions/substitutions relating to the commissioning process. Assist in resolving discrepancies.
9. Witness and document milestone events as identified in Division 23 and this Section.
10. Recommend approval of systems startup by reviewing startup reports and by selected site observation.
11. With necessary assistance and review from A/E, installing contractors, and vendors; write the performance verification procedures for equipment and systems. Analyze any performance trend logs and monitoring data to verify performance. Direct, coordinate, and/or witness equipment/systems performance verification and recommend approval. Coordinate retesting as necessary until satisfactory performance is achieved
12. Maintain a master Issues Log. Provide the County with written progress reports and test results with recommended actions.
13. Witness performance testing of select systems over which the CxA may not have direct control such as refrigerant safety monitoring systems tested by Fire Marshall, tests by manufacturer's personnel, and other County contracted tests. Assure that tests documentation is in O&M manuals.
14. Review equipment warranties to ensure that the County's responsibilities are clearly defined.
15. Witness and participate in the contractor's training of the County's operating personnel.
16. Review the O&M manuals.
17. Provide a final commissioning report (as described in this section).

PART 2 – PRODUCTS (Not Used)

PART 3 - EXECUTION

3.1 SEQUENCING AND SCHEDULING: Systems commissioning may be construed to be in three parts: installation verification, training and demonstrations, and performance verification.

- A. Installation verification utilizes Pre-Functional Check Lists, documenting that equipment/systems are installed with contract documents, are serviceable, and started in accordance contract requirements and/or manufacturers' recommendations.
- B. Contractor's training of and demonstrations for County's operating and maintenance personnel occurs after Pre-Functional Checks are complete and all test and inspection reports and operation and maintenance manuals have been submitted and approved. Training and demonstrations usually precede Performance Verification; some training, such as use and operations of the automation system, occurs during and after performance verifications.
- C. Performance verification employs Functional Performance Verification forms and occurs only after all work required in related Sections has been successfully completed. HVAC systems require functional performance verification in distinct heating and cooling seasons; i.e. a minimum of two sessions of performance verification.

3.2 MEETINGS:

- A. Initial Meeting. Within 60 days of the Notice to Proceed, CxA shall schedule an initial commissioning meeting. All commissioning parties are required to attend. CxA will issue an agenda and chair the meeting. General content of the meeting will be for the CxA to provide an overview of the commissioning process for the project, to establish lines of communications.
- B. Post-Submittal Meeting: Within 30 days of the final submittal approval by trade (mechanical, electrical, security, etc.), the CxA will schedule a coordination meeting for the concerned parties. CxA will issue an agenda and chair the meeting. General content of the meeting will be for the CxA to provide and discuss pre-functional checklists and performance verification forms.
- C. Miscellaneous Meetings. Other meetings may be planned and conducted by the CxA as construction progresses to address coordination, deficiency resolution, and planning issues.

3.3 SUBMITTALS

- A. The CxA will review the approved submittals related to the commissioned equipment for conformance to the contract documents as it relates to the commissioning process, to the performance of the equipment and adequacy for developing test procedures. This review is intended primarily to aid in the development of performance verification procedures and only secondarily to verify compliance with equipment specifications. The CxA will notify the County, PM and/or A/E as requested, of items missing or areas that are not in conformance with

contract documents.

- B. The CxA may request additional submittal documentation to facilitate the commissioning work. These requests may entail manufacturer's printed installation and detailed startup procedures, full sequences of operation, O&M data, performance test procedures, control drawings and details of owner contracted tests. All documentation requested by the CxA shall be included by the subcontractors in the O&M manuals.

3.4 CONSTRUCTION CHECKLISTS AND START-UP

- A. Pre-Functional checklists are employed to verify that the equipment and systems are fully connected and operational. Installation elements of the checklists for a given system must be successfully completed and approved prior to startup. Contractors assert completion of installations, CxA verifies contractors' assertions.
- B. Equipment startups are performed by responsible contractors and/or factory authorized technicians as required by pertinent specification sections. The primary role of the CxA in the start-up process is to ensure that there is written documentation that each of the specified start-up requirements or the manufacturer-recommended procedures has been completed. Successful start-ups shall be documented on the Pre-Functional Checklists.
- C. Execution of Pre-Functional Checklists and Startup
 - 1. The pre-functional checklists will be provided by the CxA at the Post Submittal Commissioning Meeting. Sample checklists are provided by the EMS/ATC Contractor and shall be indicative of required procedures to be executed as part of startup and initial checkout of the systems and the parties responsible for their execution. The sample pre-functional checklists will be honed responsive to approved submittals.
 - 2. The execution and approval of the pre-functional checklist and startup shall be directed and performed by the contractor, subcontractor or vendor. Signatures are required of the applicable subcontractors for verification of completion of their work.
 - 3. The contractor/subcontractor responsible for the purchase of the equipment shall develop the full startup plan by combining the manufacturer's detailed startup and checkout procedures and the construction checklists and document the successful start-up. CxA shall witness startups and verify successful startup documentation.
 - 4. The contractor shall coordinate startup and checkout with the County, A/E, and CxA. Startups requiring witnessing by the CxA and the ERU system, and the hot water boilers. In general, startup of all major pieces of equipment shall be witnessed; a sampling strategy will be used for witnessing startup of multiple similar pieces of equipment.
- D. Deficiencies, Non-Conformance, and Approval in Checklists and Startup (Issues Log).
 - 1. During the commissioning process, the Commissioning Agent may identify issues that require corrective action. The Commissioning Agent has no authority to dictate ways and means of issues resolution other than enforcing the dictates of Contract Drawings and Specifications. Resolution of issues that require interpretations or modifications to the contract documents shall be the responsibility of the Architect and Engineers. Project completion date shall not be delayed due to lack of timely issues resolution unless authorized contract extensions have been executed.

2. Written responses shall be made to issues reported by the Commissioning Agent. The Commissioning Agent shall provide status reports and issues logs as deemed appropriate during the commissioning process with original provided to County and copies to the General Contractor, and Architect. The General Contractor and/or Architect shall provide the County with a written response to each issue cited by the Commissioning Agent as to corrective actions implemented. The written response shall be provided to the County within two (2) weeks of the date of the Commissioning Agent's issues citing correspondence; copies shall be provided to the Commissioning Agent, General Contractor, and Architect. Issues that have not been fully resolved within the two week period shall be noted as such with explanation of intended resolution; and subsequent status reports of the continued issue resolution shall be made in writing at two week intervals until such time as the issue has been fully rectified. The County reserves the right to withhold partial payment for construction contract or professional services until satisfactory resolution of mechanical issues have been documented and verified.

3.5 OPERATIONS AND MAINTENANCE MANUALS

- A. The commissioning process requires detailed O&M documentation as identified in this section, Division 1, and technical specifications.
- B. Operating and Maintenance Manuals shall be provided to the Architect/Engineer for review no later than sixty (60) days after the last submittal/shop drawing has been approved. A/E shall provide the Operating and Maintenance Manuals to the Commissioning Agent after the A/E's review. The Manuals with A/E and Commissioning Agent's review comments will be returned to the Contractor for preparation for use in training of County's operating and maintenance personnel. Return of the reviewed Manuals shall be approximately six weeks after Contractor submission.
- C. Manuals format and content shall be as specified in Division 1.

3.6 DEMONSTRATIONS AND TRAINING

- A. The contractor shall provide demonstrations and training in accordance with Division 1, technical specification sections.
- B. Demonstration and training plan shall be submitted to the Commissioning Agent at the time of submission of the Operation and Maintenance Manuals. Plan shall fully detail all demonstrations and training that are to be provided by the Contractor to the County's operating and maintenance personnel and include a time allocation schedule. Actual dates and times, if used, shall be understood as tentative and subject to change based upon actual construction progress. However, at a minimum, the Demonstration and Training schedule shall include time allocations (i.e. hours) for each piece of equipment or system for which demonstration and training are specified. Commissioning agent review comments will be provided to when Operating and Maintenance Manuals are returned to the Contractor. The plan shall cover the following elements:
 1. Equipment/system
 2. Intended audience
 3. Location of training

4. Subjects covered (description, duration of discussion, special methods, etc.)
 5. Methods (classroom lecture, manufacturer's quality video, site walk-through, actual operational demonstrations, written handouts, etc.).
- C. The O&M manuals shall be incorporated into all training sessions.
1. Use the printed installation, operation and maintenance instruction material included in the O&M manuals.
 2. Review the written O&M instructions emphasizing safe and proper operating requirements, preventative maintenance, special tools needed and spare parts inventory suggestions. The training shall include startup, operation in all modes possible, shutdown, seasonal changeover and any emergency procedures.
 3. Discussion of relevant health and safety issues and concerns.
 4. Discussion of warranties and guarantees.
 5. Common troubleshooting problems and solutions.
 6. Discussion of any peculiarities of equipment installation or operation.
- D. The majority of training and demonstrations shall precede Performance Verification; some training, such as use and operations of the automation system, occurs during and after performance verifications.
- E. The CxA participation in demonstration and training is largely observation, verifying that training has given to the satisfaction of County's operating and maintenance personnel. The CxA may amplify the training sessions by explaining design concepts and systems interactions.

3.7 PERFORMANCE VERIFICATION

- A. Requirements: Performance verification shall demonstrate that each system is operating according to the design intent and contract documents. Performance verification facilitates bringing the systems from a state of individual substantial completion to full dynamic operation. All major systems, such as large air handling units, shall have performances verified by the CxA. Systems involving multiple, repeated equipment, such as VAV terminals, shall be verified by sampling.
- B. Coordination and Scheduling: The contractor shall provide sufficient notice, regarding their completion schedule for the pre-functional checklists and startup of all equipment and systems to allow the performance verification to be scheduled. The commissioning team shall oversee, witness, and document the performance all equipment and systems. The CxA in association with the contractor/subcontractors and facility staff shall execute the verifications.
1. Performance verification shall be conducted after the pre-functional checklists and startup has been satisfactorily completed.
 2. For HVAC and DHW systems, air balancing and water balancing shall be completed and all systems shall be operating under automation system control programming (automatic control) prior to performance verification.
 3. Performance verification proceeds from components to sub-systems to systems. When the proper performance of all interacting individual systems has been achieved, the interface or coordinated responses between systems shall be verified.
- C. Procedures. CxA will provide detailed performance verification procedures and forms after all

submittals, including controls, have been approved. Equipment performance shall be tested or verified per the parameters and requirements of the pertinent technical specifications and/or manufacturers' recommendations. Systems performances shall be verified per procedures of pertinent technical specifications, including Testing and Balancing of Division 23, and as further amplified by the CxA.

1. Performance testing and verification may be achieved by manual testing or by monitoring the performance and analyzing the results using the control system's trend log capabilities or by stand-alone data loggers. The CxA may substitute specified methods or require an additional method to be executed other than what was specified, with the approval of the A/E and County's Project Officer. The CxA will determine which method is most appropriate for tests that do not have a specified method.
2. Performance verification and testing shall be performed under design conditions as closely as is practically possible. Simulation of design conditions may be employed to verify performance. When simulation is used, the actual results may also require re-verification under design load conditions.
3. The Installing Contractor shall operate all equipment and systems in support of the commissioning work effort and shall provide all labor, equipment, and materials necessary to allow operational and performance verification of all commissioned equipment and systems.

D. Non-Conformance.

1. Corrections of minor deficiencies identified may be made during performance verification at the discretion of the CxA. In such cases the deficiency and resolution will be documented on the procedure form or on an attached sheet.
2. As tests progress and a deficiency is identified that cannot be immediately rectified, the CxA shall discuss the issue with the commissioning team:
 - a. When there is no dispute on the deficiency and the contractor accepts responsibility to correct it, the will document the deficiency in the Issues Log. After the contractor acknowledges correction of the deficiency in writing in the Issues Log, the contractor shall reschedule the test; and the test shall be repeated.
 - b. If there is a dispute about a deficiency, regarding whether it is a contractor issue or a design issue:
 - 1) The apparent deficiency shall be documented in the Issues Log.
 - 2) The deciding responsible party shall indicate the resolution on the Issues Log and the performance verification shall be repeated responsive to the resolution.
3. The contractor shall acknowledge in writing the status of each outstanding discrepancy identified in the Issues Log. A two week time interval shall be allowed between the date of issuance of the Issues Log and the contractor's response. Where deficiencies have not been rectified within the allotted two weeks, contractor's response shall provide explanations.
4. Failure Due to Manufacturer Defect: If 10% (or three, whichever is greater) of identical pieces of equipment fail to perform to the contract documents (mechanically or substantively) due to a manufacturing defect, not allowing it to meet its submitted performance specification, all identical units may be considered unacceptable by the A/E or CxA. In such case, the contractor shall provide the County with the following:

- a. The contractor or manufacturer's representative shall examine all other identical units making a record of the findings. The findings shall signed and dated, written explanation of the problem, cause of failures, etc., and all proposed solutions.
- b. The A/E will determine whether a replacement of all identical units or a repair is acceptable.
- c. Performance verification shall be repeated after all repairs/replacements have been completed.

E. Deferred Performance Verification

1. Unforeseen Deferred Tests. If any check or test cannot be completed due to the project completion level or required occupancy condition, execution of checklists and performance verification may be delayed upon approval of the CxA and County. These tests will be conducted in the same manner as originally required as soon as possible.
2. Seasonal Testing: During the warranty period, seasonal testing (tests delayed until weather conditions are closer to the system's design) shall be completed as part of this contract. The CxA shall coordinate this activity through the County's Project Officer. Tests will be executed, documented by the CxA and deficiencies should be corrected by the appropriate contractor/ subcontractors with the CxA witnessing. Any final adjustments to the O&M manuals and as-builts due to the testing shall be made by the contractor.

- F. **Costs for Re-Testing:** Contractor is responsible for costs of performance verification. The cost of the work of the CxA is covered by the County. However, where re-testing of a system is required due to a deficiency having been cited and the re-test again fails due to un-rectified deficiencies, the costs of the CxA associated with all subsequent re-testing may be withheld from County's payment to the contractor. **Retesting shall not be considered a justified reason for a claim of delay or for a time extension by the contractor.**

3.8 RECOMMENDED ACCEPTANCE: The CxA notes each satisfactorily demonstrated function on the performance verification forms. CxA provides all forms in he final commissioning manual delivered to the County with an executive summary recommending acceptance of the installation as complete and operating in accordance with contract requirements. Recommendation of acceptance may be conditional where:

- A. The vast majority of the work was found to be installed and operating per contract requirements, but some minor deficiencies remain. Final acceptance would be predicated upon the condition that all know deficiencies have been corrected and accepted by the County's Project Officer.
- B. The HVAC system may be conditionally accepted in the initial season of operation, with the condition that the operations in the opposite season must meet performance verification. Final acceptance of the HVAC system requires two season (i.e. heating season and cooling season) performance verification.

END OF SECTION 019113

THIS PAGE INTENSIONALLY LEFT BLANK

SECTION 020100 - SUBSURFACE INVESTIGATION

PART 1 - GENERAL

1.1 RELATED WORK

- A. Refer to Civil Site and Structural Drawings

1.2 TEST BORINGS

- A. The Owner has explored subsurface conditions by making test borings.
- B. A report titled Geotechnical Engineering Report, including Test Boring Logs, by Langan Engineering and Environmental Services, Inc, and dated September 16 July 2020 is included herein for information only. The Owner assumes no responsibility for the accuracy of the information. The report was prepared for design purposes only and may or may not be sufficient to prepare an accurate bid.
- C. The test borings are believed to be a reasonable indication of existing soil conditions. The Contractor shall verify conditions affecting the work and make his own interpretation of the test boring information.
- D. The Contractor's use of this information is at his own risk. The availability of this information does not guarantee that the entire site or soil conditions are as indicated by the report.

END OF SECTION 020100

REPORT FOLLOWS

THIS PAGE INTENSIONALLY LEFT BLANK

GEOTECHNICAL ENGINEERING REPORT

for

Arlington County Department of Human Services Group Home Arlington, Virginia

Prepared For:

**Arlington County Department of Environmental Services
Facilities Design and Construction**

Prepared By:

**Langan Engineering and Environmental Services, Inc.
1300 Wilson Boulevard, Suite 450
Arlington, Virginia 22209**

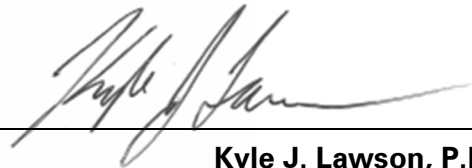

**Kyle J. Lawson, P.E.
Virginia Professional Engineer License No. 0402055790**



**Ronald T. Manney, P.E.
Professional Engineer License No. 0402053838**

LANGAN

**16 July 2020
270060006**

TABLE OF CONTENTS

1.0	EXECUTIVE SUMMARY	1
2.0	INTRODUCTION	3
3.0	PROJECT DESCRIPTION	4
4.0	REVIEW OF AVAILABLE INFORMATION	5
5.0	SUBSURFACE INVESTIGATION	6
6.0	SUBSURFACE CONDITIONS	8
7.0	DESIGN RECOMMENDATIONS	11
8.0	CONSTRUCTION RECOMMENDATIONS	15
9.0	CLOSURE/LIMITATIONS	20

FIGURES

Figure 1	Site Location Map
Figure 2	Investigation Location Plan
Figure 3	USDA Soil Survey Map
Figure 4	Regional Geologic Map
Figure 5	Lateral Earth Pressures on Below-Grade Walls

APPENDICES

Appendix A	Boring Logs
Appendix B	Infiltration Test Results
Appendix C	Laboratory Test Data

1.0 EXECUTIVE SUMMARY

This report presents the findings of our geotechnical engineering study for the proposed Arlington County Department of Human Services Group Home at 1212 South Irving Street in Arlington, Virginia. This executive summary does not represent a complete summary of our project understanding and recommendations; the report is one cohesive document and should be read in its entirety.

The site is located at the northwest side of the intersection of South Irving Street and 13th Street South and is bound by South Irving Street to the east, 13th Street South to the south, and houses to the north and west. The site has a 2.5-story house at the west portion of the site, a grassy area with a few trees at the east-southeast portions of the site, and an asphalt driveway/parking area at the northeast portion of the site.

We understand that the existing house will be demolished and a new three-story, approximate 3,500 square foot group house will be constructed in its place at the center of the site. A new parking area will be constructed at the northeast portion of the site. Landscaping and hardscaping will be updated throughout the site. A new stormwater management facility is planned at the southeast portion of the site.

We performed a geotechnical investigation on 1 and 2 July 2020 that consisted of drilling four borings and performing two infiltration tests. Subsurface conditions at the site generally consist of surficial topsoil or asphalt overlying successive strata of silt, upper clay, sand, and lower clay and are summarized as follows:

- Topsoil: Topsoil consisted of dark brown silt with varying amounts of clay and sand with trace roots. The topsoil was observed to be 4 to 6 inches thick.
- Stratum A – Silt: The upper 1.5 and 3.7 feet consisted of firm to hard silt with varying amounts of sand and clay with trace amounts of coarse gravel and cobbles.
- Stratum B – Upper Clay: The Upper Clay stratum was observed to be between 4 and 5 feet thick and contained varying amounts of sand and silt.
- Stratum C – Sand: Stratum C consisted of primarily sand with varying amounts gravel, silt, and clay. The sand stratum was observed to be medium dense to very dense and between 23.5 and 27.5 feet thick.
- Stratum D – Lower Clay: The lower clay was observed to be very stiff and contain varying amounts of sand and silt.
- Groundwater: Groundwater was first encountered at approximately 18 and 18.5 feet below grade, or between el 186 and 187. Groundwater after completion of the drilling was recorded at approximately 17.2 feet below grade or at el 188.3.

A summary of pertinent information and our recommendations based on our geotechnical investigation are as follows:

- The subsurface conditions are suitable for supporting structures on shallow foundations using an allowable bearing pressure of 4 ksf for foundations at the basement level and 3 ksf for foundations near existing grade. Shallow foundations should bear on new structural fill or natural soils. We recommend that localized fill, if encountered at the subgrade, be over-excavated and replaced with structural fill or the footing be lowered to bear on natural soil.

- The lowest level floor slab of the proposed building can be designed as conventional slab-on-grade bearing on natural soils or on new structural fill using a modulus of subgrade reaction of 120 pci. The slab should be underlain by a minimum 10 mil vapor barrier and minimum 4 inches of No. 57 stone.
- The new building can be designed using a seismic site class of "D".
- Excavated soil in the upper 4 to 5 feet are expected to have a high percentage of fines and should only be reused as backfill in landscaped areas. Stratum C soil will be encountered during excavation for the basement level and deep utilities and we anticipate a majority of excavated Stratum C soils can be reused as structural fill.
- We anticipate that a majority of the excavations at the site can be completed using temporary construction slopes at a 1H:1V (OSHA Type B Soils) where sufficient space exists.
- Infiltration testing was completed in and yielded infiltration rates ranging from 0.01 to 3.13 inches per hour. The high variation in infiltration rates is likely due to clay seams present in Stratum C near the proposed bottom of basin elevation.
- Excavations for the proposed basement level, foundations, and site utilities are anticipated to be above the groundwater table. However, seasonal perched water may be encountered along the interface of Strata A and B.
- We anticipate that rainwater/surface runoff and perched water can be controlled during construction using conventional submersible pumps in conjunction with gravel filled trenches or sumps. Surface ditches or berms should be used to prevent surface runoff from entering the excavations.

Additional discussion of the investigation, subsurface conditions, and our geotechnical design and construction recommendations are provided in the following sections.

2.0 INTRODUCTION

This report presents the results of our geotechnical engineering study performed for the proposed Arlington County Department of Human Services Group Home at 1212 South Irving Street in Arlington, Virginia. The purposes of this study were to:

- 1) Research and review available site information;
- 2) Obtain subsurface information by drilling borings, performing infiltration tests, and collecting soil samples for specialty laboratory testing, and
- 3) Provide recommendations for geotechnical aspects of the proposed redevelopment;

Existing grades and elevations at the site are referenced from the site plan prepared by Arlington County. No environmental testing or analysis was completed as part of our study.

3.0 PROJECT DESCRIPTION

3.1 Existing Conditions

The site is located 1212 South Irving Street in Arlington, Virginia and is located within a residential housing zone. The site is bordered by residential properties to the north and west, 13th Street South to the south and South Irving Street to the east. The site is owned by Arlington County and currently contains a 2.5-story, detached group home. The site is covered in grass and vegetation at the east-southeast portion and an asphalt driveway at the northeast portion of the site, see Inset 1.



Inset 1

Site grades are relatively flat and gently slope from approximate el 206 at the west to el 203 at the east.

3.2 Proposed Construction

Based on our review of 15 June 2020 design development drawing package, the existing house will be demolished and replaced by an approximate 3,500-square-foot group home constructed at the center of the site. The new building will have a ground finished floor elevation of 207 indicating fill ranging from 1 to 3 feet around the outside of the building. We understand that the building will have a basement level that extends about 9.3 feet below grade, or to el 197.7. The new building will contain five bedrooms, four bathrooms, a kitchen, a dining room, a living room, and staff space. At the time of this report, we have not been provided structural loads for the building but we have assumed loading for similar structures.

One or two bio-retention stormwater management facilities are proposed at the south portion of the site. We understand that the bottoms of these basins are proposed at about el 196, or 8 feet below existing grade. The proposed development will also include a parking lot with six parking spaces adjacent to South Irving Street, concrete and hardscape walkways, and new landscaping.

4.0 REVIEW OF AVAILABLE INFORMATION

We reviewed available historic aerial photographs, soil maps, and regional geologic maps for the site. Pertinent information obtained from these documents is summarized in the following sections.

4.1 Historic Aerials

We reviewed available aerial photographs for the site dated 1949, 1951, 1962, 1963, 1964, 1979, 1980, 1981, 1982, 1988, 1994, 2002, 2003, 2005, 2006, 2007, 2008, 2009, 2011, 2012, 2013, 2014, and 2016. These photographs are described below.

1949-1951: These photographs depict the existing structure at the west part of the site and vegetation consisting of shrubs and trees at the east part of the site. The site is within a residential neighborhood.

1962: This photograph depicts similar site conditions to the 1951 photograph. Additional houses are west of the site along 13th Street South.

1963-2012: These photographs depict similar site conditions to the 1962 photograph.

2013-2014: These photographs depict similar site conditions to the 2012 photograph. About 500 feet north of the site, the construction of apartment buildings and restaurants at the intersection of Glebe Road and Columbia Pike is visible in these photographs.

2016: This photograph depicts conditions to the existing site.

4.2 Soil Map

We reviewed the United States Department of Agriculture (USDA), Natural Resources Conservation Service Web Soil Survey; see Figure 3. Based on this database service, the near surface soils underlying the site are classified as Urban Land consisting of human-transported soils from the Sassafra and Neabsco Complexes. The hydrologic soil groups of the Sassafra and Neabsco Complexes are B and D, respectively.

4.3 Regional Geologic Map

We reviewed the Geologic Map entitled "Simplified Geologic Map of Arlington, Virginia, and Vicinity" prepared by the GIS Mapping Center in Arlington, Virginia and dated 2010; see Figure 3. Based on this map, the site is underlain by the Terrace Deposits placed in the late Pliocene by the Potomac River. Terrace deposits are generally composed of sandy gravel, gravelly sand, sand, silt, and clay.

5.0 SUBSURFACE INVESTIGATION

Our geotechnical investigation consisted of drilling four geotechnical borings and conducting two infiltration tests. Details of the subsurface investigation are given in the following sections. Permission to access the site was obtained through Arlington County prior to mobilizing to the site.

5.1 Borings

Borings LB-1 through LB-4 were drilled on 1 July 2020 by Free State Drilling Inc. using a CME track-mounted drill rig and hollow-stem auger drilling techniques. The borings were advanced to a depths ranging from approximately 14 to 35 feet below existing grades. Surface elevations were inferred from the site plan provided by Arlington County.

A standard 2-inch-outer-diameter split-spoon sampler was used to obtain samples of the underlying soil strata. The Standard Penetration Test (SPT)¹ was accomplished as part of the sampling procedure (in accordance with ASTM D-1586) and the results were recorded by our inspecting engineer. An automatic hammer was used as part of the SPT test for all sampling in the borings. Our field engineer used a field pocket penetrometer to measure unconfined compressive strengths of disturbed cohesive soil samples. Borings were backfilled with soil cuttings upon completion.

The borings were completed under the full-time observation of an engineer from our office under the supervision of our project professional engineer. Our field engineer laid out the boring locations, maintained logs of explorations, classified encountered soil, and obtained representative material samples. The individual boring logs are given in Appendix A.

5.2 Infiltration Tests

Infiltration tests were completed at two locations identified as INF-1 and INF-2. Test INF-1 is offset from boring LB-3 and test INF-2 is offset from boring LB-4. The infiltration test locations were coordinated with Arlington County and were completed in accordance with the 2013 Virginia Department of Environmental Quality (VA DEQ) Infiltration and Soil Testing Guide, Appendix 8-A.

The infiltration testing consisted of advancing an approximate 6-inch-outer-diameter hollow-stem auger to a depth of 8 and 10 feet below grade where the most restrictive infiltration layer was located in the offset borehole. A 4-inch-diameter PVC pipe was installed to the bottom of each borehole. Depth to the base of each borehole was measured and the bases were cleaned out using hand auger equipment to confirm installation to the correct depth.

In accordance with the VA DEQ, a minimum of 2 feet of water was added to the casing to pre-soak the soils. The water added as part of the pre-soak was allowed to saturate for approximately 24 hours prior to beginning the tests.

Following the pre-soak period, water was added to the casing until a minimum of 2 feet of water was measured at the bottom of the casing. Our field engineer measured the drop in water level at varying

1. The Standard Penetration Test (SPT) is a measure of the soil density and consistency. The SPT N-value is defined as the number of blows required to drive a 2-inch O.D. split-barrel sampler 12 inches, after an initial penetration of 6 inches using a 140-pound hammer falling freely for 30 inches.

intervals dependent upon the soil infiltration rates. The infiltration tests were completed four times at each location. Following the completion of infiltration testing, the PVC pipe was pulled from each test location and test holes were backfilled with soil cuttings. Infiltration test measurements and results are provided in Appendix B.

5.3 Laboratory Testing

Soil samples were visually examined in the field, and classifications were confirmed by re-examination in our Arlington, Virginia office. Select samples were sent to a specialty testing laboratory where the following tests were performed:

- Grain Size Analysis
- Water Content
- Atterberg Limits

The laboratory testing results are discussed together with the soil strata descriptions in the following sections. The laboratory test results are given in Appendix C.

6.0 SUBSURFACE CONDITIONS

Subsurface conditions generally consist of a surficial layer of topsoil overlying successive strata of silt, upper clay, sand/gravelly sand, and lower clay. A summary of depths and thicknesses of each stratum is given in Table 1.

Subsurface Conditions						
Stratum	Top Depth From Existing Grade (feet)		Top Elevation (feet)		Thickness (feet)	
	Shallowest	Deepest	Shallowest	Deepest	Min	Max
Topsoil	At Surface		At Surface		0.3	0.5
A - Silt	0.3	0.5	205.2	203.5	1.5	3.7
B – Upper Clay	2	4	203.5	200	4	7
C – Sand	6	9	198	196	23.5	27.5
D – Lower Clay	32.5	33.5	173	170.5	ND	

Table 1

Notes:

1. ND = Not Determined, the bottom of the stratum was not encountered in the borings

Because an automatic hammer was used in conjunction with the standard penetration testing in the borings, the SPT N-values presented in the text of the following strata description sections are corrected SPT N_{60} -values. SPT N-values presented in the boring logs are uncorrected SPT N-values. The following sections describe the subsurface and groundwater conditions encountered during our investigation.

6.1 Surficial Materials

Topsoil consisting of dark brown silt with varying amounts of clay and fine- to coarse-grained sand and trace roots was encountered at all borings and was approximately 4 to 6 inches thick. An asphalt driveway is located at the northeast side of the site; however, no borings were completed within the asphalt.

6.2 Stratum A - Silt

Stratum A consisted of light brown and brown silt with varying amounts fine to coarse sand, clay, and trace amounts of coarse gravel and cobbles. Cobbles encountered were estimated to be up to 6 inches in diameter based on the auger spoils. Consistency of encountered silt ranged from firm to hard as evidenced by SPT N_{60} -values ranging from 8 to 30 blows per foot (average of 18 blows per foot). Laboratory test results for select samples within Stratum A are given in Table 2.

Stratum A Laboratory Test Results

Test	Minimum	Maximum
Moisture Content (%)	13.8	
Gravel (%)	0	0.5
Sand (%)	14.7	25.4
Fines (%)	74.1	85.3
Liquid Limit (%)	34	
Plastic Limit (%)	16	
Plasticity Index (%)	18	

Table 2

Notes:

1. One value is provided when only one test was completed.
2. Averages are not provided if two or less samples were tested.

6.3 Stratum B – Upper Clay

Stratum B was encountered in all borings and consisted of gray, reddish brown, and orange-brown clay with varying amounts of fine to coarse sand and silt. Stratum B was observed to be very stiff as evidenced by SPT N_{60} -values ranging from 23 to 28 blows per foot (average of 24 blows per foot). Pocket penetrometer testing on disturbed samples from this stratum resulted in unconfined compressive strengths greater than 4.5 tsf. Laboratory test results for select samples within Stratum B are given in Table 3.

Stratum B Laboratory Test Results

Test	Minimum	Maximum
Moisture Content (%)	17.3	17.5
Gravel (%)	0	
Sand (%)	32.1	
Fines (%)	67.9	
Liquid Limit (%)	49	
Plastic Limit (%)	17	
Plasticity Index (%)	32	

Table 3

Notes:

1. One value is provided when only one test was completed.
2. Averages are not provided if two or less samples were tested.

6.4 Stratum C - Sand

Stratum C was encountered in all borings and consisted of gray, orange-brown, reddish brown, and brown fine to coarse sand with varying amounts of fine to coarse gravel, silt, and clay. Lenses of clay and silt were encountered in the upper portions of Stratum C. Borings LB-3 and LB-4 for the stormwater management basins were terminated in this stratum. Stratum C was observed to be medium dense to very dense as evidenced by SPT N_{60} -values ranging from 25 to 67 blows per foot (average of 50 blows per foot). Laboratory test results for select samples of Stratum C are given in Table 4.

Stratum C Laboratory Test Results

Test	Minimum	Maximum	Average
Moisture Content (%)	10.7		
Gravel (%)	17.2	35.7	28.4
Sand (%)	49.5	64.8	55.7
Fines (%)	11.5	18.2	15.9

Table 4

Notes:

1. One value is provided when only one test was completed.
2. Averages are not provided if two or less samples were tested.

6.5 Stratum D – Lower Clay

Stratum D was encountered in borings LB-1 and LB-2 and consisted of orange-brown clay with varying amounts of fine to coarse sand and silt. Stratum D was observed to be very stiff as evidenced by SPT N_{60} -values ranging from 23 to 26 blows per foot. Pocket penetrometer testing on disturbed samples resulted in unconfined compressive strengths ranging from 1.5 to 3.25 tsf (average of 2.3 tsf). Laboratory testing of a select sample from Stratum D yielded a moisture content of 31.2 percent.

6.6 Groundwater

Groundwater was first encountered in borings LB-1 and LB-2 at depths of 18 and 18.5 feet below grade or between el 186 and 187. After completion, groundwater was measured in boring LB-1 at depth of approximately 17.2 feet below grade or at el 188.3. Groundwater upon completion could not be measured in boring LB-2 due to the borehole caving in at a depth of approximately 13 feet below grade. Groundwater was not encountered in borings LB-3 and LB-4 to their maximum termination depths of 14 feet below grade.

7.0 DESIGN RECOMMENDATIONS

Based on our investigation findings and anticipated relatively light structural loads associated with a residential building, the site conditions are generally suitable to support the new structure on shallow foundations and traditional slab-on-grade floor slabs.

Our geotechnical recommendations for foundation support, floor slab design, seismicity, below-grade walls, and infiltration test results are given in the following sections.

7.1 Foundation Support

We recommend that the new structure be supported on shallow foundations bearing on natural soils or new structural fill.

- We recommend that foundations bearing near existing grade be designed using an allowable bearing pressure of 3 ksf. Foundations should not bear directly on existing fill soil if encountered at the site. If existing fill is encountered at the footing subgrade, we recommend it be over-excavated below the footing. The over-excavation should be replaced with compacted structural fill or the footing should be lowered to the base of the over-excavation to natural soil.
- We recommend that foundations for the basement be designed using an allowable bearing pressure of 4 ksf. These foundations must bear on natural soil below el 196.

We recommend that continuous footings have a minimum width of 1.5 feet and a minimum embedment of 2.5 feet for bearing capacity and frost considerations. Isolated column footings should have a minimum dimension of 3 feet and a minimum embedment of 2.5 feet. These dimensions should be the minimum even if smaller dimensions are justified using the allowable bearing pressures recommended above. See Section 8.2 for footing subgrade preparation procedures.

Lateral loads can be resisted by shear resistance developed at the base of the footings. We recommend an ultimate friction coefficient value of 0.35 be used for mass concrete associated with foundations placed against natural soils or on new structural fill.

We estimate that settlements for shallow foundations will be less than 1 inch and differential settlement of adjacent structure footings is estimated to be less than 0.5 inches, provided the subgrade is prepared in accordance with the recommendations provided herein. Structural loads, once available, should be provided for our review to verify our recommendations.

7.2 Floor Slabs

We recommend that the proposed lowest level floor slab consist of conventional slab-on-grade construction bearing on properly proofrolled and prepared subgrades consisting of new structural fill or natural soils. Existing fill, if encountered in localized areas at the slab subgrade, should be over-excavated a minimum of 1.5 feet below the slab and recompacted in controlled lifts; see Section 8.2 for our subgrade preparation recommendations.

We recommend the designer use a modulus of subgrade reaction of 120 pci for slabs bearing on properly prepared subgrades. The recommended modulus value is for a 12x12-inch square plate and must be corrected for the slab size. Slabs should be supported on a minimum of 4 inches of No. 57

stone drainage course and have a minimum 10 mil vapor barrier installed between the slab and drainage course.

7.3 Seismicity

Based on our subsurface investigation, the 2015 Virginia Construction Code (VCC), the 2015 International Building Code (IBC), and the United States Geological Survey, the proposed new structure can be designed using Seismic Site Class = "D" (Stiff Soil Profile).

7.4 Below-Grade Walls

Below-grade walls are required for the basement are presumed to be fixed against rotation, and should therefore be designed to resist soil, surcharge, earthquake, and dynamic pressures. Below-grade walls can be designed using the following equivalent fluid pressures (wall height, H, in feet); see Table 5 and Figure 4 for details.

Below-Grade Wall Design Parameters

Conditions		Parameters
Soil Properties	Backfill moist unit weight	125 pcf
	Backfill internal angle of friction	28 degrees
At-Rest Case	Lateral at-rest earth pressure coefficient	$K_0 = 0.53$
	Equivalent at-rest fluid pressure ⁽¹⁾⁽²⁾	66H psf
Active Case	Active earth pressure coefficient	$K_a = 0.36$
	Equivalent passive fluid pressure ⁽¹⁾⁽²⁾	45H psf
	Earthquake-induced lateral force ⁽³⁾	$1.8H^2$ lb/ft

Table 5

Notes:

1. "H" indicates the height of below-grade wall below the ground surface in feet.
2. The earthquake force should be placed at a depth of 0.4H (H in feet) below the top of the earth-retaining portion of the wall if the structure is rated as Seismic Design Categories D through F. If included, the earthquake force should be included with "active" case lateral earth pressures.

The provided equivalent soil pressures presume the following conditions:

- Walls are fully drained following the recommendations of 7.4.1. Walls extending below el 190 will need to include hydrostatic pressure and should be reviewed by our firm.
- On-site fill or granular soils are used to backfill against the wall or the below-grade wall is placed directly against support of excavation.
- No surface surcharge and/or structure loads exist at the top of the walls.
- No factor of safety is included.

The designer should adjust the pressures based on these factors. Additional loads for design of below-grade walls should include the surface surcharge loading on below-grade walls, including adjacent floor slabs, footings, and vehicular roadways. These loads should be included by multiplying the

surcharge stress by the applicable pressure coefficient (k_o or k_s) and then adding this uniform stress to the soil loading.

7.4.1 Below-Grade Wall Drainage

All below-grade walls should be dampproofed at a minimum. Below-grade walls should include a perimeter drainage system including a vertical drain extending to a perimeter foundation drain. The perimeter foundation drain should be installed at the base of all below-grade walls and below the bottom of the lowest slab. The foundation drain should consist of a minimum 4-inch-diameter perforated Schedule 40 PVC or HDPE pipe (or as determined by the project MEP engineer) and be surrounded by a minimum of 6 inches of No. 57 or 67 drainage stone in all directions. The stone surrounding the pipe should be wrapped in filter fabric overlapped a minimum of 6 inches at the ends. Drainage pipes should convey the collected water to the building sump system or to the site storm sewer system for off-site disposal.

A vertical drain consisting of drainage panels (i.e. Miradrain 6000 or approved alternative) or a 12-inch-thick column of free-draining crushed stone should be used to collect any water that may accumulate behind these walls, and route the water down to the drains. A layer of filter fabric should be installed to separate the crushed stone from the on-site soils and prevent the movement of fines. This vertical drain should start 12 inches below the final outside grade.

Langan will need to review these drainage and protection recommendations if the below-grade walls extend below el 190 to determine if waterproofing is required.

7.5 Pavement Design

A parking lot will be installed at the north portion of the site as part of the redevelopment. Based on the subsurface conditions, we recommend that the pavement be designed using a CBR of 5. We recommend that the pavement consist of at least 3 inches of Superpave SM-9.5 or 12.5 overlying a minimum of 6 inches of aggregate subbase consisting of VDOT 21B. We recommend that an asphalt prime coat be placed after installation of the subbase.

7.6 Infiltration Test Results

Two infiltration tests were performed at the site to establish infiltration rates for the design of proposed stormwater management facilities. Infiltration testing locations were coordinated with Arlington County. A summary of our infiltration test results is given in Table 6. Infiltration test logs are given in Appendix B.

Summary of Infiltration Test Results

Infiltration Test Designation	Test Depth (ft)	Test Elevation	Average Infiltration Rate (in/hr)
INF-1	10	195	3.13
INF-2	7.75	196.25	0.01

Table 6

The infiltration tests were performed within Stratum C, which is primarily composed of sand with varying amounts of gravel and clay. However, Stratum C was observed to contain lenses of clay and silt, which likely contributed to the low infiltration test results at INF-2. Based on the results, we recommend that bio-retention basins be designed using an allowable infiltration rate of 0.5 in/hour to account for the possible variability at the bottom of basins.

8.0 CONSTRUCTION RECOMMENDATIONS

Our geotechnical recommendations for demolition and site preparation, subgrade preparation, engineered fill, and other aspects of geotechnical construction are discussed in the following sections.

8.1 Demolition and Site Preparation

Prior to commencement of excavation or grading, miscellaneous trash, debris, or other unsuitable materials should be removed from the site. All unsuitable materials should be properly disposed off-site in accordance with Virginia, Arlington County, and local regulations.

Topsoil should be stripped from below and 5 feet beyond wherever fill will be placed and building and pavement areas. The topsoil should be stockpiled and protected from erosion. The reuse of on-site topsoil should be evaluated by a landscape architect.

At this time, we recommend the following regarding site demolition:

- Existing utilities designated for abandonment should be completely removed beneath the proposed new building footprint. Utilities designated for abandonment outside of the building footprint should be completely removed or abandoned in-place by filling with grout.
- Excavations made to remove utilities should be backfilled with approved compacted fill as discussed in Section 8.3 of this report.
- All existing utilities to be maintained during construction should be field located and marked at the surface prior to the start of demolition.
- Any existing pavement or walkway designated for removal should be demolished in their entirety. Existing asphalt that is milled can be reused as subbase for new walkways.
- Existing slabs associated with structures should be completely removed in all areas of the site.
- Existing foundations and below-grade walls should be completely removed below the new proposed structure. Existing foundations and below-grade walls may be left in-place deeper than 3 feet below grade in pavement and landscaped areas. The project civil engineer should review any planned remnant walls and foundations to verify they do not impact proposed utility routing.
- Proper dust control measures should be implemented during demolition, milling, and earthwork at the site.

All site demolition and site preparation work should be performed in accordance with any environmental regulations and requirements established for the site as well as Virginia, Arlington County, and local regulations.

All site preparation activities should be performed in strict accordance with the approved soil erosion and sediment control plan prepared for the project. All soil erosion and sediment control features should be protected and maintained throughout construction. All work should be performed so as not to adversely impact the existing and neighboring off-site structures, wetlands, roadways, or utilities. Protection of these elements should be provided as necessary during the course of all construction activities at the site.

8.2 Subgrade Preparation

8.2.1 Slab and Pavement Subgrade

Localized existing fill, if encountered, should be over-excavated a minimum of 1.5 feet below slab-on-grade subgrades and replaced with structural fill or recompacted in controlled lifts. Existing fill is not required to be over-excavated below pavement subgrades provided it meets the subsequent preparation and proofroll recommendations.

The subgrades within proposed building and pavement footprints should be compacted to at least 97 percent of the material's maximum dry density in accordance with ASTM D698 after performing the aforementioned site preparation work and prior to placing compacted fill to raise site grades or constructing finished surfaces. We recommend that the final subgrade below slab and pavement areas then be proofrolled with at least three passes of a 5-ton smooth drum vibratory roller. This proofroll should extend at least 5 feet beyond the outer edge of structural areas and be conducted before placement of the subbase/drainage course and before installation of shallow utilities to prevent damage.

All proofroll activities should be inspected by a qualified geotechnical engineer. Additional proofrolling should be performed in any areas deemed necessary by the engineer. Soft areas identified during proofrolling should be undercut and replaced with approved fill.

Care should be taken to prevent disturbance of the proofrolled areas prior to finished construction. At a minimum, all soil subgrade areas potentially exposed to the weather should be temporarily sloped and sealed with a smooth drum roller at the end of each working day to maximize surface water runoff, and minimize potential ponding and infiltration.

8.2.2 Shallow Foundation Subgrades

Natural Stratum B soils or approved structural fill supporting shallow foundations should be level, proofrolled, and compacted using a 5-ton smooth-drum vibratory roller prior to footing construction. A double-drum walk-behind vibratory compactor such as a Wacker RT 82-SC or equivalent can be used to proofroll areas of tight maneuverability including at the base of any shear keys (if required per the foundation design).

Footings should not bear directly on existing fill soils. If encountered, existing fill soils should be over-excavated and replaced with structural fill or the footing lowered to bear directly on natural soil.

Footing subgrades must be inspected and approved by the geotechnical testing agency prior to footing construction. Any soft, loose, or unsuitable soils identified by the geotechnical engineer during proofrolling should be removed and replaced with approved compacted fill or lean concrete.

We recommend that footing concrete be placed immediately after subgrade preparation to minimize deterioration of the footing subgrade. Soils may deteriorate in the presence of moisture even after the subgrade is properly prepared. If concrete for footing construction cannot be placed the same day as subgrade preparation and poor weather is anticipated, we recommend that the footing subgrades be protected with a thin lean concrete mud mat or 3 inches of No. 57 stone. Any unprotected subgrade exposed to rain events should be re-inspected prior to concrete placement. Footing excavations should be backfilled as soon as possible after the footing concrete placement and curing.

8.2.3 Utility Trench Subgrades

Utility trench subgrades should be excavated to depths that account for bedding as shown on the civil drawings or as recommended by the pipe manufacturer. Exposed utility trenches should be proofrolled with at least three overlapping coverages of a double-drum walk-behind vibratory compactor and moisture conditioned to within 3 percentage points of optimum water content. Any soft or unstable areas identified by the proofrolling should be removed and replaced with compacted fill. Backfill in utility excavations should meet requirements for fill placement and compaction given in Section 8.3.

8.3 Engineered Fill

8.3.1 Fill Designation

Structural fill should be used beneath the proposed pavement, walks, and building footprints. We recommend that structural fill have no more than 35 percent fines (silt and clay), a liquid limit not more than 40, and a plasticity index not more than 15. Structural fill should be classified as GW, GM, SW, SP, SM, or a combination of these in accordance with USCS classifications. Structural fill should not contain man-made debris (unless it is pre-approved processed recycled aggregate) or organics. The maximum particle size should not exceed 2 inches within the top 18 inches of fill placed and not exceed 4 inches below.

Pavement subbase should meet criteria of VDOT 21A or 21B material.

Recycled concrete materials or milled asphalt should not be used as backfill within stormwater management basins, directly behind retaining walls, or as pavement subbase.

Non-structural fill should be used in all other areas of the site and should not have particles exceeding 3 inches within the uppermost foot of final grade and 6 inches below. Soils classified as CH, MH, OL, and PT in accordance with USCS should not be used at the site as backfill.

8.3.2 Reuse of Existing On-site Soils

We anticipate the uppermost 4 and 5 feet of soil (Strata A and B) will not meet the requirements of structural fill (Section 8.3.1); therefore, we recommend that excavated portions of these soils be reused as backfill in landscaped areas only. Stratum C soil will be encountered below about 5 feet below grade during excavation for the basement level and deep utilities. We anticipate that a majority of excavated portions of Stratum C can be reused directly as structural fill.

Stratum A and B soils have a relatively high percentage of fines and are expected to be difficult to handle, place, and compact if they become excessively wet. During periods of wet weather, the Contractor should make provisions to dry portions of the excavated material using methods such as discing/air drying or addition of lime/Portland cement to achieve an acceptable moisture content as determined by the project Geotechnical Engineer prior to compaction.

The Contractor's ability to work with the site soils and seasonal weather conditions during the site preparation and filling phases of construction will have a significant impact on timely project completion. Care should be taken to prevent disturbance of proofrolled areas and softening of materials prior to finished construction.

8.3.3 Imported Fill

Imported fill should meet the structural or subbase requirements described in Section 8.3.1. The use of any imported fill containing a higher percentage of fines will need to be evaluated by a qualified geotechnical engineer during construction. Any approved imported fill should be “certified clean fill” free of all hazardous substances and meeting all Virginia, Arlington County, and local regulations. The Contractor should provide documentation of compliance to the project geotechnical engineer prior to delivery of any fill to the site. Grain size distribution, maximum dry density, and optimum water content determinations should be made based on representative samples of the backfill and fill materials proposed by the Contractor.

8.3.4 Fill Placement and Compaction

Fill should be compacted to the following requirement for the given applications:

- Structurally-Supported Areas – Fill placed within building limits and beneath slabs-on-grade and pavements should be placed in uniform lifts and compacted to at least 97 percent of the material’s maximum dry density as determined by the Standard Proctor Compaction Test (ASTM D698).
- Exterior Landscaped Areas – Fill placed in exterior landscaped areas not supporting engineered slopes or retaining walls should be compacted to at least 92 percent of the material’s maximum dry density as determined by ASTM D698.

Site backfill should be placed in maximum 10 to 12-inch-thick loose lifts depending on the material and compacted using a roller with a minimum static drum weight of 5 tons. Typically, sand and silt soils should be compacted with a smooth drum roller and clay soils should be compacted using a sheeps-foot roller. Smaller compaction equipment (i.e. walk-behind trench roller or jumping jack compactor) and a maximum loose lift size of 6 inches may be necessary in areas of limited maneuverability, such as within trenches or within 10 feet of any structure. The water content at the time of compaction should be within 3 percentage points of the optimum. All fill placement should be subject to inspection and testing by a qualified geotechnical engineer.

Nuclear density tests (or other approved methods) should be performed on every lift of soil that is placed within building and pavement areas. At a minimum, density tests should be performed for every 1,500 square feet of subgrade within building and pavement footprints, and a minimum of two tests for each lift of a work area.

During periods of wet weather, the Contractor should make provisions to dry portions of the excavated soils to an acceptable moisture content as determined by the project Geotechnical Engineer of Record prior to compaction by methods such as discing/air drying.

Fill material should not be placed in areas of standing water, on snow-covered subgrades, on frozen subgrades, or on surfaces not approved by geotechnical testing.

8.4 Temporary Excavation Support

Based on our review of the latest site plans, we anticipate that excavation for the basement and most on-site utilities can be completed using temporary slopes. We anticipate that excavation for the east and south sides of the stormwater management facility and for utilities within the existing roadways will require excavation support.

Where sufficient space exists at the site to allow for open cuts, temporary construction slopes can be used. We recommend that temporary construction slope excavations in these strata be no steeper than OSHA "Type B" slopes (1.H:1V). These recommended maximum slope angles should be followed unless a steeper slope is approved by the contractor's Competent Person based on the subsurface conditions exposed at the time of construction.

If temporary slopes are exposed for extended periods of time, weathering may cause unwanted sloughing and erosion, especially in Strata A and B. Construction slopes should be excavated in accordance with OSHA regulations and state of Virginia safety requirements, including but not limited to proper sloping and/or shoring.

If temporary excavation support is required, the excavation support should utilize a pre-engineered system be designed by a Professional Engineer licensed in the state of Virginia. Temporary and permanent surcharge loading due to traffic, cranes, equipment, soil stockpiles, and roads should be considered while selecting or designing excavation support and be clearly defined in the supporting calculations.

8.5 Groundwater and Surface Water Management During Construction

Groundwater was first encountered at approximately 18 to 18.5 feet below grade, or between el 186 and 187. Groundwater after completion of the drilling was recorded at approximately 17.2 feet below grade or at el 188.3. Based on these measurements we recommend using a groundwater elevation of 190 for design.

We anticipate that excavations for the proposed foundations and site utilities will be above the groundwater table. Seasonal perched water may be encountered at the interface of Strata A and B.

We expect that rainwater/surface runoff and perched water can be controlled using conventional submersible pumps in conjunction with gravel filled trenches or sumps. Surface ditches or berms should be used to prevent surface runoff from entering the excavations.

The pumping, handling, and discharge of all dewatering effluent should be performed in accordance with all Virginia, Arlington County, and Federal regulations.

9.0 CLOSURE/LIMITATIONS

This report presents our recommendations regarding the geotechnical aspects for the proposed new Arlington County Department of Human Services Group Home at 1212 South Irving Street in Arlington, Virginia. These recommendations are based on our site subsurface investigation, information and drawings provided by Arlington County, and review of available information. Recommendations given are contingent upon one another and no recommendation should be followed independent of the others. Final drawings and structural loads should be provided to our office to confirm our recommendations. Langan Engineering and Environmental Services, Inc. cannot assume responsibility for the use of this report to generate recommendations for other than the specific site and structures addressed in this report.

FIGURES

- Figure 1 – Site Location Map**
- Figure 2 – Investigation Location Plan**
- Figure 3 – USDA Soil Survey Map**
- Figure 4 – Regional Geology Map**
- Figure 5 – Lateral Earth Pressures on Below-Grade Walls**

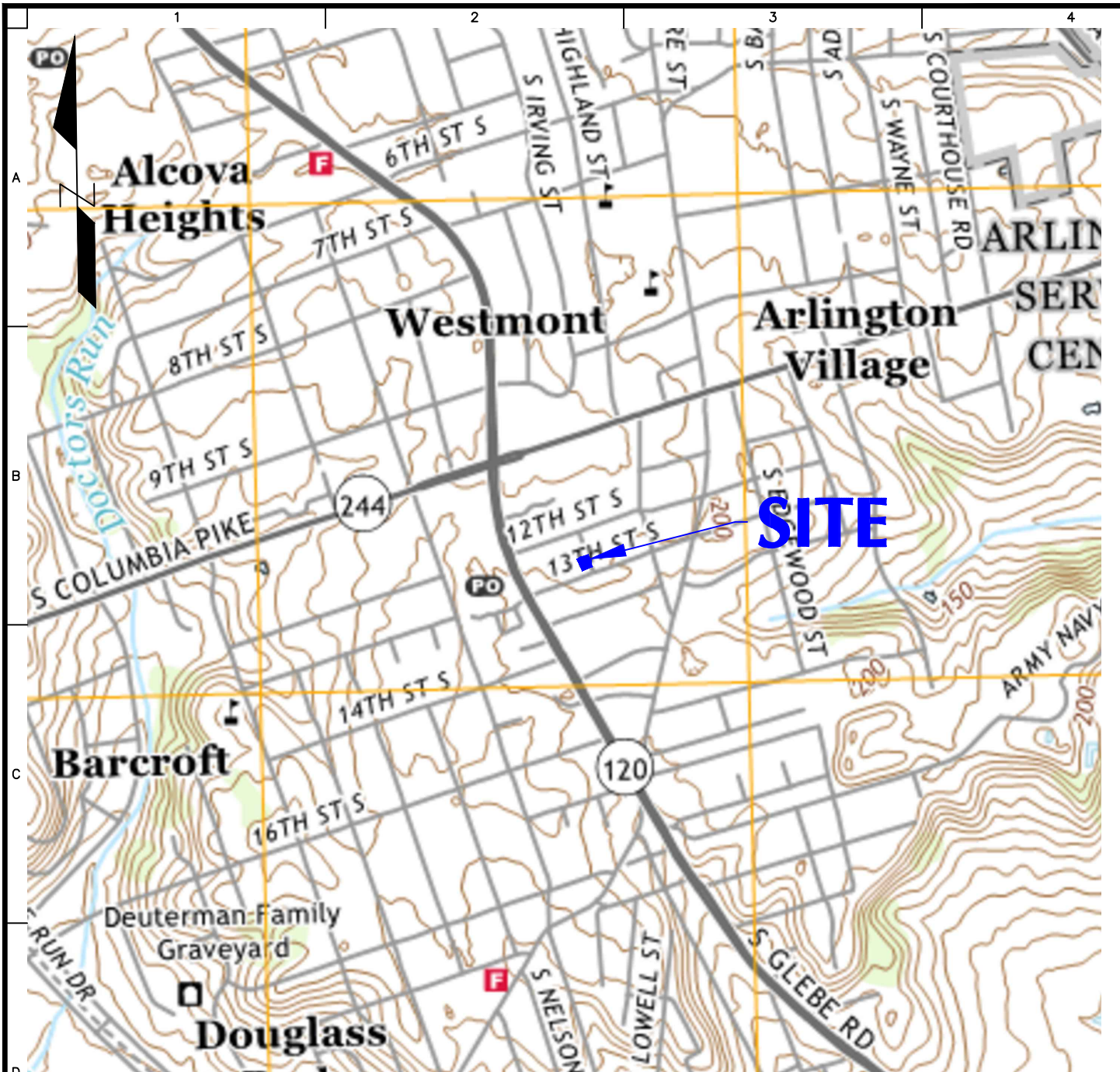

SOURCE: ALEXANDRIA QUADRANGLE, VIRGINIA, DISTRICT OF COLUMBIA, MARYLAND 7.5 MINUTE SERIES, DATED 2019.

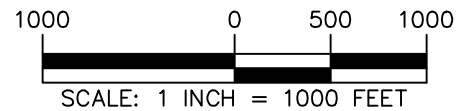

LANGAN

Langan Engineering and Environmental Services, Inc.
1300 Wilson Boulevard, Suite 450
Arlington, VA 22209

T: 571.366.6800 F: 571.366.6801 www.Langan.com

Project

**ARLINGTON COUNTY
DHS GROUP HOME**

ARLINGTON

VIRGINIA

Drawing Title

**SITE LOCATION
MAP**

Project No.

270060006

Date

7/16/2020

Drawn By

BHS

Checked By

KJL

Drawing No.

1

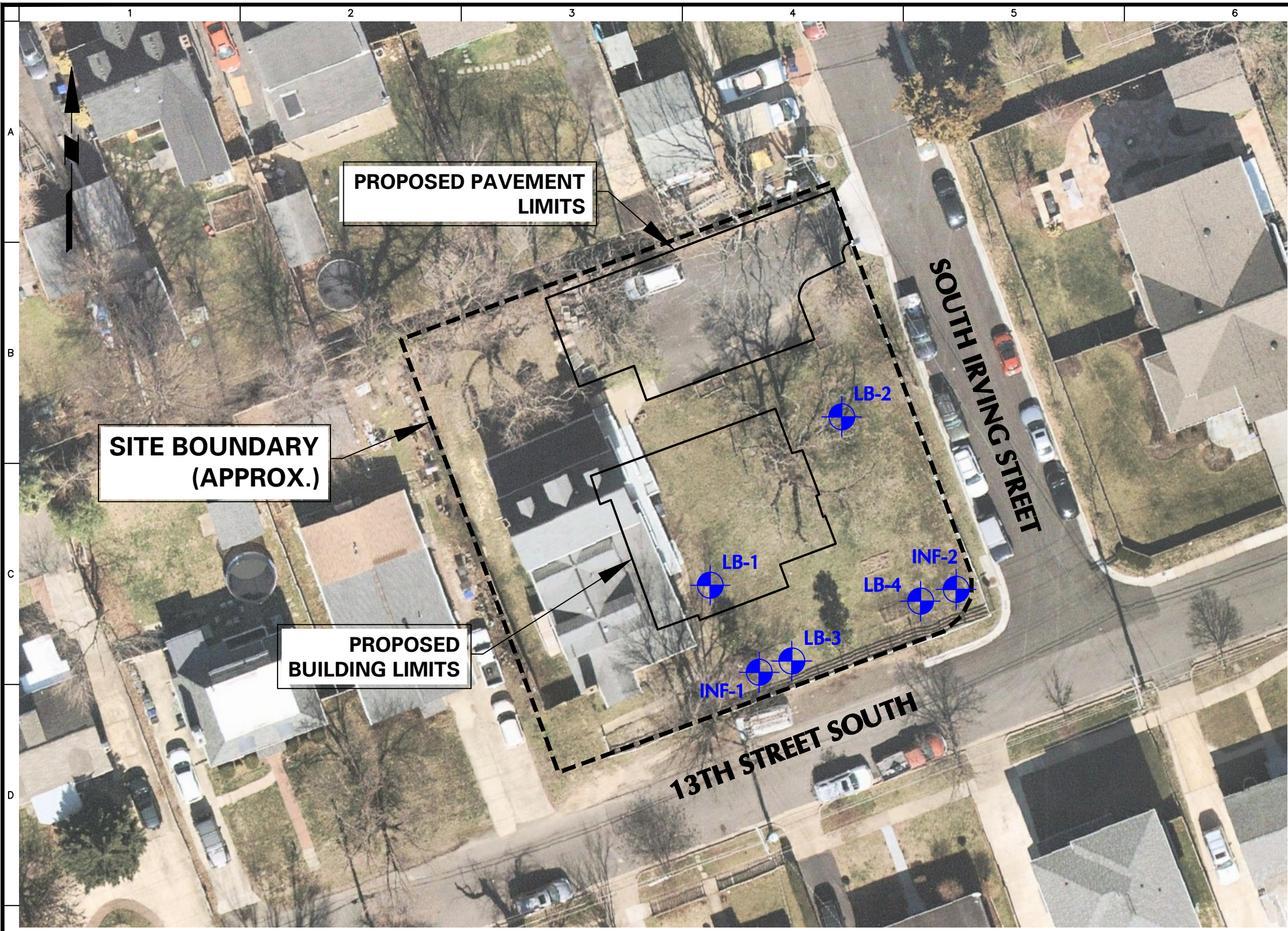

Sheet 1 of 5





NOTES:

1. BACKGROUND AERIAL IS REFERENCED FROM NEARMAP, ACCESSED 25 JUNE 2020.
2. BORINGS LB-1 THROUGH LB-4 AND INFILTRATION TESTS INF-1 AND INF-2 WERE DRILLED BY FREE STATE DRILLING INC. ON 1 JULY 2020 UNDER THE DIRECT SUPERVISION OF LANGAN ENGINEERING AND ENVIRONMENTAL SERVICES.
3. FOR DETAILED DESCRIPTIONS OF THE SUBSURFACE CONDITIONS, SEE APPENDIX A FOR THE BORING LOGS.
4. ALL BORING AND INFILTRATION TEST LOCATIONS ARE APPROXIMATE.

LEGEND

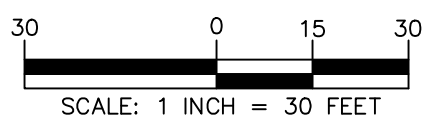
-  **LB-1** BORING LOCATION
-  **INF-1** INFILTRATION TEST LOCATION



 Langan Engineering and Environmental Services, Inc. 1300 Wilson Boulevard, Suite 450 Arlington, VA 22209 T: 571.366.6800 F: 571.366.6801 www.langan.com	Project	Drawing Title	Project No.	Drawing No.
	ARLINGTON COUNTY DHS GROUP HOME	INVESTIGATION LOCATION PLAN	270060006	2
	ARLINGTON	VIRGINIA	Date	
			7/16/20	
			Drawn By	Sheet
			BHS	2 of 5
			Checked By	
			KJL	

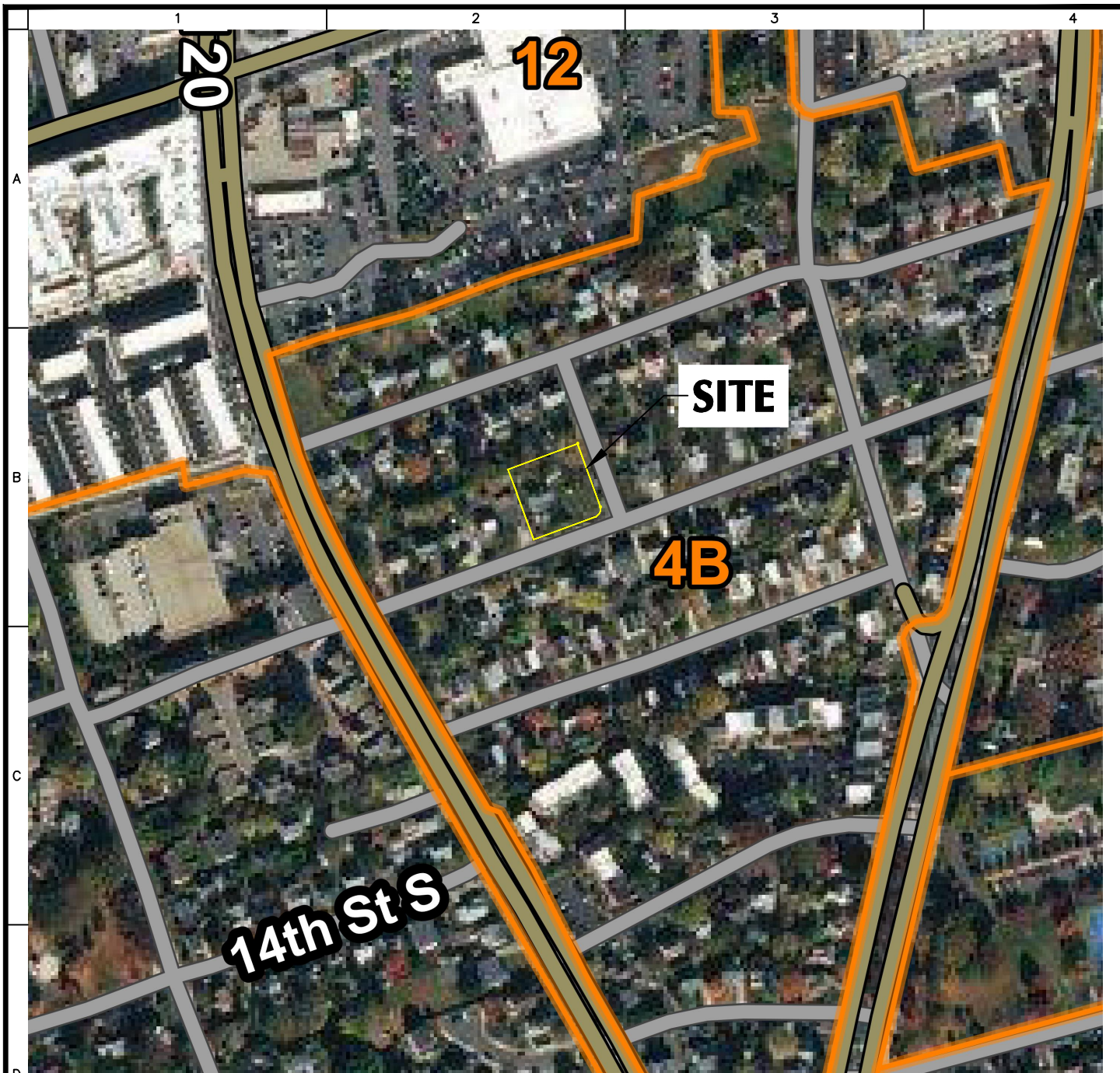

SOURCE: UNITED STATE DEPARTMENT OF AGRICULTURE (USDA) WEB SOIL SURVEY, ACCESSED 15 JULY 2020.

LEGEND:

- 4B - URBAN LAND - SASSAFRAS-NEABSCO COMPLEX, 3-8 PERCENT SLOPES
- 12 - URBAN LAND - UDORTHENTS, 2-15 PERCENT SLOPES

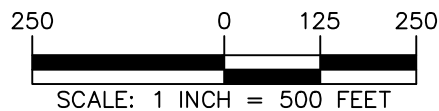

LANGAN
 Langan Engineering and
 Environmental Services, Inc.
 1300 Wilson Boulevard, Suite 450
 Arlington, VA 22209

T: 571.366.6800 F: 571.366.6801 www.langan.com

Project
**ARLINGTON COUNTY
 DHS GROUP HOME**

ARLINGTON VIRGINIA

Drawing Title
**USDA SOIL
 SURVEY MAP**

Project No.
 270060006
 Date
 7/16/2020
 Drawn By
 BHS
 Checked By
 K.J.L.

Drawing No.
3
 Sheet 3 of 5

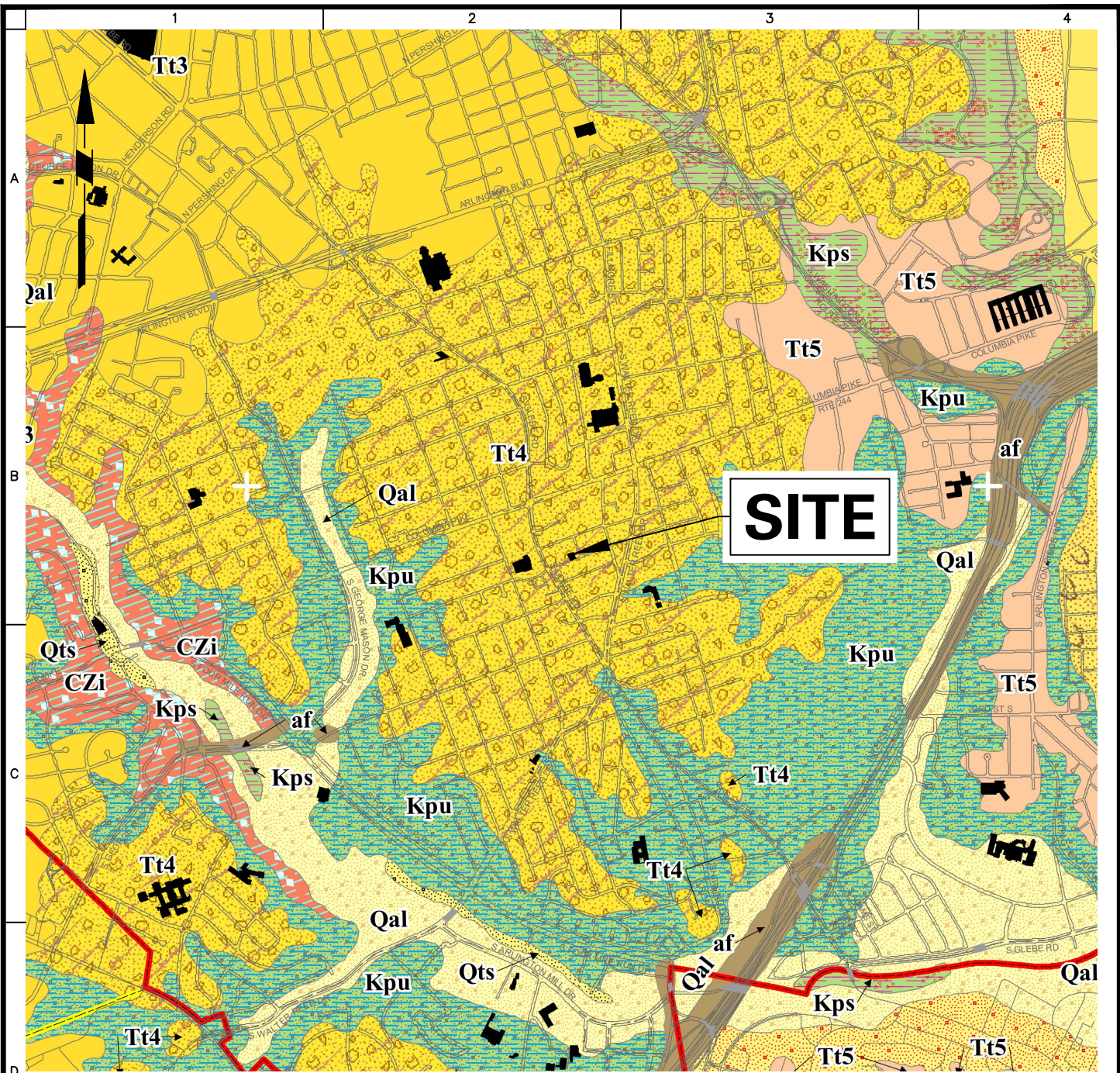

SOURCE: SIMPLIFIED GEOLOGIC MAP OF ARLINGTON, VIRGINIA AND VICINITY PREPARED BY THE GIS MAPPING CENTER IN ARLINGTON, VIRGINIA, DATED JUNE 2010.

LEGEND:

- Tt4 TERRACE DEPOSITS - CRUDELY BEDDED GRAVEL, SAND, SILT AND CLAY
- Kpu POTOMAC FORMATION - CLAY AND SILT INTERBEDDED WITH PEBBLY SAND
- Qal ALLUVIUM - UNCONSOLIDATED SAND, SILT, CLAY, AND GRAVEL FLUVIAL DEPOSITS
- Tt5 TERRACE DEPOSITS - LESS WEATHERED

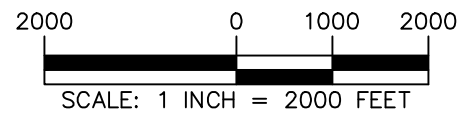

LANGAN
 Langan Engineering and Environmental Services, Inc.
 1300 Wilson Boulevard, Suite 450
 Arlington, VA 22209
 T: 571.366.6800 F: 571.366.6801 www.langan.com

Project
**ARLINGTON COUNTY
 DHS GROUP HOME**
 ARLINGTON VIRGINIA

Drawing Title
**REGIONAL
 GEOLOGIC MAP**

Project No.
270060006
 Date
7/16/2020
 Drawn By
BHS
 Checked By
KJL

Drawing No.
4
 Sheet 4 of 5

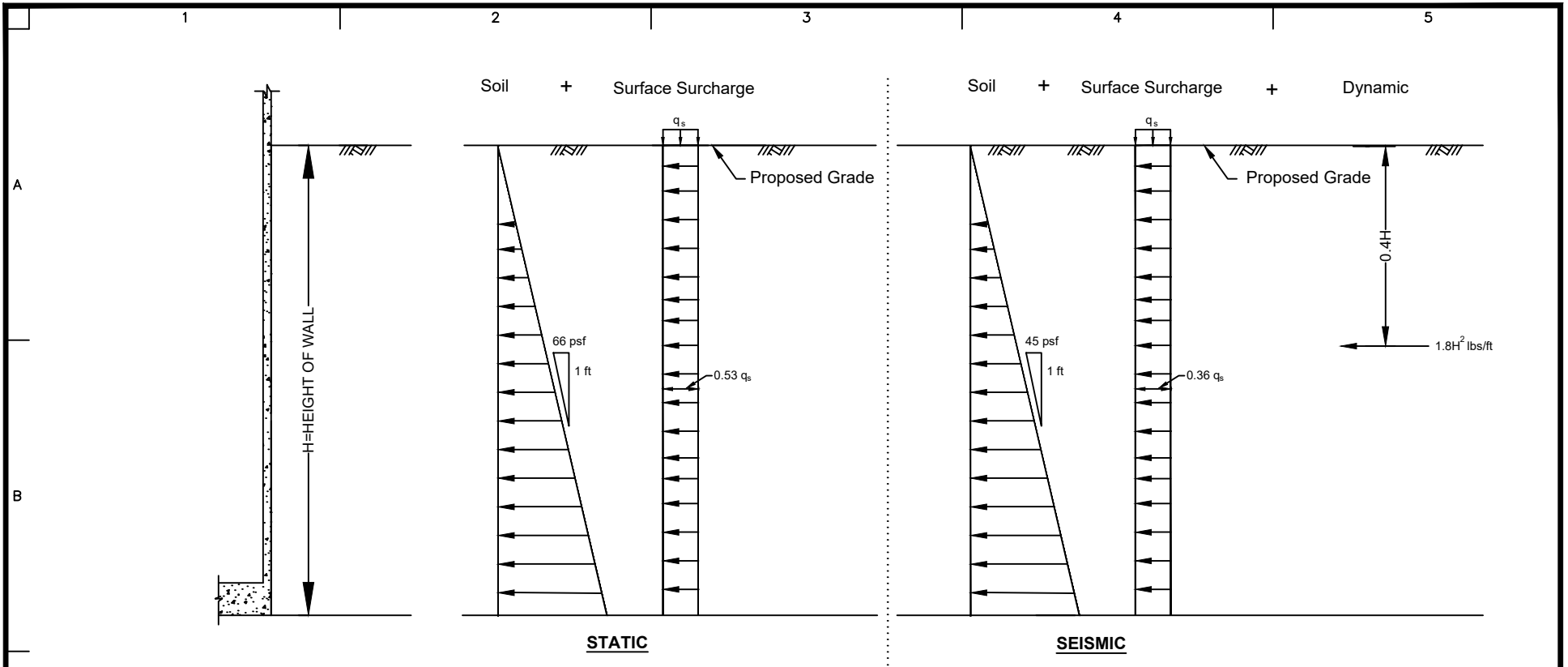

NOTES:

1. Wall Designer to evaluate below-grade walls based on static condition (at-rest earth pressure) as needed.
2. Diagrams shown are a simplified representation of various lateral loads for use in the design of below-grade foundation walls.
3. The above parameters presume that full drainage is provided behind below-grade walls for walls above the groundwater elevation. The pressures given in this figure should be adjusted in accordance with Section 7.4 of the Geotechnical Report if inadequate drainage is provided behind the wall.
4. No factors of safety are included in the earth pressures provided in the diagram.
5. These parameters and recommendations assume the basement has one level and extends to no deeper than el 190. Walls extending below el 190 may need to include hydrostatic pressure and should be reviewed by our firm.

LANGAN

Langan Engineering and
Environmental Services, Inc.
1300 Wilson Boulevard, Suite 450
Arlington, VA 22209

T: 571.366.6800 F: 571.366.6801 www.langan.com

Project

**ARLINGTON COUNTY
DHS GROUP HOME**

ARLINGTON

VIRGINIA

Drawing Title

**LATERAL EARTH
PRESSURES ON
BELOW-GRADE WALLS**

Project No.

270060006

Date

7/16/20

Drawn By

BHS

Checked By

KJL

Drawing No.

5

Sheet 5 of 5

Appendix A

Boring Logs

I:\LANGAN.COM\DATA\ARL\DATA\0270060006\PROJECT DATA\ DISCIPLINE\GEO\TECHNICAL\GINTLOGS\270060006 - S. IRVING STREET BORINGS.GPJ ... 7/16/2020 11:46:23 AM ... Report: Log - LANGAN

Project 1212 South Irving Street Redevelopment			Project No. 270060006		
Location Arlington, Virginia			Elevation and Datum Approx. el 205.5 ft		
Drilling Company Free State Drilling Inc.			Date Started 7/1/20		Date Finished 7/1/20
Drilling Equipment CME 55 Track-Mounted Drill Rig			Completion Depth 35 ft		Rock Depth NE
Size and Type of Bit 3-1/4" I.D. HSA			Number of Samples Disturbed 10		Undisturbed 0
Casing Diameter (in) -			Casing Depth (ft) -		Core 0
Casing Hammer -			Weight (lbs) -		Drop (in) -
Sampler 2" O.D. Split Spoon Sampler			Water Level (ft.) First 18.5		
Sampler Hammer Automatic			Weight (lbs) 140		Drop (in) 30
			Drilling Foreman Ronald Stidham		
			Field Engineer Benjamin Sperry		

MATERIAL SYMBOL	Elev. (ft)	Sample Description	Depth Scale	Sample Data				N-Value (Blows/ft) 10 20 30 40	Remarks (Drilling Fluid, Depth of Casing, Fluid Loss, Drilling Resistance, etc.)
				Number	Type	Recov. (in)	Penetr. resist B/blin		
	205.5		0						Began drilling at 11:00. SS 0 to 2 ft
	205.2	Dark brown Sandy SILT, trace roots (moist) [TOPSOIL] Brown Sandy SILT, coarse gravel in spoon tip (moist)	1	S-1	SS	4	4	20	Auger grinding and rig chatter from 1 to 2 feet due to coarse gravel and cobbles. Augered to 2 ft. SS 2 to 4 ft
	203.5	Brown Silty CLAY, some f-c sand (moist)	2	S-2	SS	13	13	27	
	201.5	Gray and reddish brown CLAY, some f-c sand (moist)	4	S-3	SS	4	9	22	Augered to 4 ft. SS 4 to 6 ft q _u > 4.5 tsf
	196.5	Gray, orange-brown, and reddish brown CLAY, some f-c sand, trace silt (moist)	6	S-4	SS	6	7	20	Augered to 6 ft. SS 6 to 8 ft q _u > 4.5 tsf
		Gray, orange-brown, and reddish brown CLAY, some f-c sand, trace silt (moist)	8	S-5	SS	6	11	31	Augered to 8 ft. SS 8 to 10 ft
		Gray f-c SAND, some f-c gravel, trace clay (moist)	9			24	20		Augered to 13.5 ft.
			10			24	29		
		Gray and orange-brown Gravelly f-c SAND (moist)	14	S-6	SS	6	17	38	Auger grinding from 13 to 13.5 ft. SS 13.5 to 15 ft
			15			6	20		Augered to 18.5 ft.
			16			18			

Project		Project No.							
1212 South Irving Street Redevelopment		270060006							
Location		Elevation and Datum							
Arlington, Virginia		Approx. el 205.5 ft							
MATERIAL SYMBOL	Elev. (ft)	Sample Description	Depth Scale	Sample Data				Remarks (Drilling Fluid, Depth of Casing, Fluid Loss, Drilling Resistance, etc.)	
				Number	Type	Recov. (in)	Penetr. resist. BL/6in		N-Value (Blows/ft)
	189.5		16						
			17						
			18						
		Orange-brown Gravelly f-c SAND, trace clay, trace silt (moist to wet)	19	S-7	SS	6	9	41	SS 18.5 to 20 ft
			20				19		Augered to 23.5 ft.
			21				22		
			22						Hard augering and auger grinding from 22 to 23.5 ft.
			23						
		Orange-brown Gravelly f-c SAND, trace silt (wet)	24	S-8	SS	8	22	32	SS 23.5 to 25 ft
			25				18		Augered to 28.5 ft. Auger grinding from 24.5 to 28.5 ft; moderate rig chatter.
			26				14		
			27						
			28						
		Orange-brown f-c SAND, trace silt, coarse gravel in spoon tip (wet)	29	S-9	SS	4	25		SS 28.5 to 30 ft
			30				20	47	Augered to 33.5 ft. Auger grinding and moderate rig chatter from 30 to 32.5 ft.
			31				27		
			32						
	173.0	Orange-brown CLAY, some f-c sand, some silt (wet)	33						
			34	S-10	SS	18	4		SS 33.5 to 35 ft $q_u = 1.5$ to 2.25 tsf
			35				8	17	
	170.5	End of Boring at 35 ft.	35				9		End of drilling at 12:35. Borehole backfilled with soil cuttings upon completion.
			36						

I:\LANGAN.COM\DATA\ARLIDA\A01270060006\PROJECT DATA\ DISCIPLINE\GEO\TECHNICAL\GINTLOGS\270060006 - S. IRVING STREET BORINGS.GPJ ... 7/16/2020 11:46:24 AM ... Report: Log - LANGAN

I:\LANGAN.COM\DATA\ARLIDATA\0270060006\PROJECT DATA\ DISCIPLINE\GEO\TECHNICAL\GINTLOGS\270060006 - S. IRVING STREET BORINGS.GPJ ... 7/16/2020 11:46:27 AM ... Report: Log - LANGAN

Project 1212 South Irving Street Redevelopment			Project No. 270060006		
Location Arlington, Virginia			Elevation and Datum Approx. el 204 ft		
Drilling Company Free State Drilling Inc.			Date Started 7/1/20		Date Finished 7/1/20
Drilling Equipment CME 55 Track-Mounted Drill Rig			Completion Depth 35 ft		Rock Depth NE
Size and Type of Bit 3-1/4" I.D. HSA			Number of Samples Disturbed 10		Undisturbed 0
Casing Diameter (in) -			Casing Depth (ft) -		Core 0
Casing Hammer -			Weight (lbs) -		Drop (in) -
Sampler 2" O.D. Split Spoon Sampler			Water Level (ft.) First 18		
Sampler Hammer Automatic			Weight (lbs) 140		
			Drop (in) 30		
			Drilling Foreman Ronald Stidham		
			Field Engineer Benjamin Sperry		

MATERIAL SYMBOL	Elev. (ft)	Sample Description	Depth Scale	Sample Data				Remarks (Drilling Fluid, Depth of Casing, Fluid Loss, Drilling Resistance, etc.)	
				Number	Type	Recov. (in)	Penetr. resist Blows/in		N-Value (Blows/ft)
	204.0		0						
	203.5	Dark brown SILT, some clay, trace f-m sand, trace roots (moist) [TOPSOIL]							Began drilling at 10:15. SS 0 to 2 ft
		Light brown SILT, some clay, trace f-m sand, trace roots (moist)	1	S-1	SS	20	3	7	
	202.0	Orange-brown and brownish gray CLAY, some f-c sand, trace silt (moist)	2				4		Augered to 2 ft. SS 2 to 4 ft q _u > 4.5 tsf
			3	S-2	SS	24	3	21	
	200.0	Gray and grayish brown CLAY, trace f-m sand (moist)	4				8		Augered to 4 ft. SS 4 to 6 ft q _u > 4.5 tsf
			5	S-3	SS	24	5	21	
	198.0	Gray and reddish brown Clayey f-c SAND, trace silt (moist)	6				9		Augered to 6 ft. SS 6 to 8 ft
			7	S-4	SS	24	6	22	
	196.0	Gray and tan f-c SAND, some f-c gravel, trace silt (moist)	8				10		Augered to 8 ft. SS 8 to 10 ft
			9	S-5	SS	24	12	24	
			10				12		Augered to 13.5 ft.
			11				13		
			12				13		
			13				13		
		Gray and orange-brown f-c SAND, some f-c gravel, trace silt (moist to wet)	14	S-6	SS	18	8	17	SS 13.5 to 15 ft
			15				12	20	Augered to 18.5 ft.
			16				15		

Project		Project No.						
1212 South Irving Street Redevelopment		270060006						
Location		Elevation and Datum						
Arlington, Virginia		Approx. el 204 ft						
MATERIAL SYMBOL	Elev. (ft)	Sample Description	Depth Scale	Sample Data				Remarks (Drilling Fluid, Depth of Casing, Fluid Loss, Drilling Resistance, etc.)
				Number	Type	Recov. (in)	Penetr. resist. BL/6in	
							10 20 30 40	
	188.0		16					Auger grinding from 16.5 to 17.5 ft. Coarse gravel in cuttings.
			17					
			18					
	185.5	Brown and gray Gravelly f-c SAND, some clay (wet)		S-7	SS	5	9	SS 18.5 to 20 ft
			19			5		
			20			31		Augered to 23.5 ft.
			21					
			22					
			23					Hard augering and moderate rig chatter from 22.5 to 23.5 ft. Coarse gravel in cuttings.
	180.5	Gray and tan Gravelly f-c SAND, some silt (wet)		S-8	SS	18	21	SS 23.5 to 25 ft
			24			16		
			25			15		Augered to 28.5 ft. Hard augering and auger grinding from 24 to 27.5 ft.
			26					
			27					
			28					
	175.5	Brown Gravelly m-c SAND, trace silt (wet)		S-9	SS	14	31	SS 28.5 to 30 ft
			29			20		
			30			22		Augered to 33.5 ft.
			31					
			32					
			33					
	170.5	Orange-brown CLAY, some f-c sand, some silt (wet)		S-10	SS	18	6	SS 33.5 to 35 ft $q_u = 3.25$ tsf
			34			3		
			35			9		End of drilling at 11:00. Borehole collapsed at 12.8 ft upon auger extraction. Borehole backfilled with soil cuttings upon completion.
	169.0	End of Boring at 35 ft.						
			36					

I:\LANGAN.COM\DATA\ARL\DATA\0270060006\PROJECT DATA\ DISCIPLINE\GEO\TECHNICAL\GINTLOGS\270060006 - S. IRVING STREET BORINGS.GPJ ... 7/16/2020 11:46:28 AM ... Report: Log - LANGAN

I:\LANGAN.COM\DATA\ARL\DATA\0270060006\PROJECT DATA\DISCIPLINE\GEO\TECHNICAL\GINTLOGS\270060006 - S. IRVING STREET BORINGS.GPJ ... 7/16/2020 11:46:31 AM ... Report: Log - LANGAN

Project 1212 South Irving Street Redevelopment			Project No. 270060006		
Location Arlington, Virginia			Elevation and Datum Approx. el 205 ft		
Drilling Company Free State Drilling Inc.			Date Started 7/1/20		Date Finished 7/1/20
Drilling Equipment CME 55 Track-Mounted Drill Rig			Completion Depth 14 ft		Rock Depth NE
Size and Type of Bit 3-1/4" I.D. HSA			Number of Samples	Disturbed 5	Undisturbed 0
Casing Diameter (in) -			Casing Depth (ft) -	Water Level (ft.) First NE	Completion NE
Casing Hammer -	Weight (lbs) -	Drop (in) -	Drilling Foreman Jim Rosebrock		
Sampler 2" O.D. Split Spoon Sampler			Field Engineer Benjamin Sperry		
Sampler Hammer Automatic	Weight (lbs) 140	Drop (in) 30			

MATERIAL SYMBOL	Elev. (ft)	Sample Description	Depth Scale	Sample Data				Remarks (Drilling Fluid, Depth of Casing, Fluid Loss, Drilling Resistance, etc.)		
				Number	Type	Recov. (in)	Penetr. resist. Blows/in		N-Value (Blows/ft)	
	205.0		0							
	204.5	Dark brown SILT, some f-m sand, trace roots (moist) [TOPSOIL]								Began drilling at 08:25. SS 0 to 2 ft
		Brown to light brown Sandy SILT, trace roots (moist)	1	S-1	SS	16			17	Cobble encountered at 1 ft.
			2							Augered to 4 ft.
	201.0	Gray and brown CLAY, some f-m sand, some silt (moist)	4							SS 4 to 6 ft $q_u > 4.5$ tsf
			5	S-2	SS	24			26	Augered to 8 ft.
			6							
	197.0	Brown CLAY, trace f-m sand, trace silt (moist)	8							Augered to 8 ft.
	196.5	Gray and orange-brown f-c SAND, some f-c gravel, some clay (moist)	9	S-3	SS	24			54	SS 8 to 10 ft $q_u > 4.5$ tsf at 8.2 ft
	195.0	Gray and orange-brown Gravelly f-c SAND, trace clay lenses, trace silt (moist)	10							Augered to 10 ft. SS 10 to 12 ft
			11	S-4	SS	24			51	
			12							Augered to 12 ft. Auger grinding at 11 ft. SS 12 to 14 ft
		Gray and orange-brown f-c SAND, some f-c gravel, trace silt (moist)	13	S-5	SS	18			43	
	191.0	End of Boring at 14 ft.	14							End of drilling at 08:55. Borehole collapsed at 10 ft upon auger extraction. Borehole backfilled with soil cuttings upon completion.
			15							
			16							

I:\LANGAN.COM\DATA\ARL\DATA\0270060006\PROJECT DATA\DISCIPLINE\GEO\TECHNICAL\GINTLOGS\270060006 - S_IRVING STREET BORINGS.GPJ ... 7/16/2020 11:46:33 AM ... Report: Log - LANGAN

Project 1212 South Irving Street Redevelopment			Project No. 270060006		
Location Arlington, Virginia			Elevation and Datum Approx. el 204 ft		
Drilling Company Free State Drilling Inc.			Date Started 7/1/20		Date Finished 7/1/20
Drilling Equipment CME 55 Track-Mounted Drill Rig			Completion Depth 14 ft		Rock Depth NE
Size and Type of Bit 3-1/4" I.D. HSA			Number of Samples Disturbed 5		Undisturbed 0
Casing Diameter (in) -			Casing Depth (ft) -		Core 0
Casing Hammer -			Weight (lbs) -		Drop (in) -
Sampler 2" O.D. Split Spoon Sampler			Water Level (ft.) First NE		
Sampler Hammer Automatic			Weight (lbs) 140		Drop (in) 30
			Drilling Foreman Ronald Stidham		
			Field Engineer Benjamin Sperry		

Elev. (ft)	Sample Description	Depth Scale	Sample Data					Remarks (Drilling Fluid, Depth of Casing, Fluid Loss, Drilling Resistance, etc.)
			Number	Type	Recov. (in)	Penetr. resist (in)	N-Value (Blows/ft)	
204.0		0						
203.7	Dark brown SILT, trace f-m sand, trace roots (moist) [TOPSOIL] Brown SILT, some clay, trace f-c sand (moist)	1	S-1	SS	18	3	7	Began drilling at 09:25. SS 0 to 2 ft
		2						Augered to 4 ft.
200.0	Gray, brownish gray, and reddish brown CLAY, some silt, some f-m sand (moist)	4	S-2	SS	24	4	20	SS 4 to 6 ft q _u > 4.5 tsf
		5						Augered to 8 ft.
196.0	Gray and orange-brown f-c SAND, some fine gravel, some clay (moist)	8	S-3	SS	24	7	41	Augered to 8 ft. SS 8 to 10 ft
194.0	Gray and light brown f-c SAND, some f-c gravel, trace silt (moist)	10	S-4	SS	23	9	47	Augered to 10 ft. SS 10 to 12 ft
	Gray and brown to light brown f-c SAND, some f-c gravel, trace silt (moist)	12	S-5	SS	18	10	45	Augered to 12 ft. SS 12 to 14 ft
190.0	End of Boring at 14 ft.	14						End of drilling at 09:50. Borehole collapsed at 10 ft upon auger extraction. Borehole backfilled with soil cuttings upon completion.

Appendix B

Infiltration Test Results

BOREHOLE INFILTRATION TEST

1212 South Irving Street Redevelopment
Arlington VA
270060006

BOREHOLE: INF-1

Test Dimensions

Casing Diam: 4 in
Casing Length: 11.00 ft
Pipe Stick-Up: 1 ft
Surface Elevation: 205 ft
Test Elevation: 195.0 ft

Pre-Soak

Initial Soak

Date:	7/1/2020	Date	7/1/20
Time:	9:20 AM	Time	1:01 PM
Water Depth:	9.35 ft	Water Depth below casing (ft)	9.85
Height of Water:	1.65 ft		

24-Hour Results

Date: 7/2/2020
Time: 7:58 AM
Water Depth: **10.20**
Height of Water: **0.80**

Test Information

Date: 7/2/2020
Casing Length: 11.00 ft

Start Time	Time Interval (hour)	Depth to Water from Top of Pipe (ft)	Height of Water in Pipe (ft)	Water Drop in Interval (ft)	Infiltration Rate (ft/h)	Increment Infiltration Rate (in/hr)
Test #1						
8:02 AM	Start	8.77	2.23	-	-	-
8:17 AM	0:15	8.95	2.05	0.18	0.72	8.64
8:32 AM	0:15	9.04	1.96	0.09	0.36	4.32
8:48 AM	0:16	9.10	1.90	0.06	0.23	2.70
9:02 AM	0:14	9.13	1.87	0.03	0.13	1.54

Test #1 Infiltration Rate: 4.32

Test #2						
9:03 AM	Start	8.69	2.31	-	-	-
9:17 AM	0:14	8.78	2.22	0.09	0.39	4.63
9:32 AM	0:15	8.85	2.15	0.07	0.28	3.36
9:48 AM	0:16	8.89	2.11	0.04	0.15	1.80
10:03 AM	0:15	8.93	2.07	0.04	0.16	1.92

Test #2 Infiltration Rate: 2.88

Test #3						
10:04 AM	Start	8.61	2.39	-	-	-
10:19 AM	0:15	8.69	2.31	0.08	0.32	3.84
10:34 AM	0:15	8.73	2.27	0.04	0.16	1.92
10:49 AM	0:15	8.78	2.22	0.05	0.20	2.40
11:04 AM	0:15	8.80	2.20	0.02	0.08	0.96

Test #3 Infiltration Rate: 2.28

Test #4						
11:05 AM	Start	8.38	2.62	-	-	-
11:19 AM	0:14	8.47	2.53	0.09	0.39	4.63
11:32 AM	0:13	8.53	2.47	0.06	0.28	3.32
11:47 AM	0:15	8.58	2.42	0.05	0.20	2.40
12:02 PM	0:15	8.62	2.38	0.04	0.16	1.92

Test #4 Infiltration Rate: 3.03

RESULT		
Lowest Infiltration Rate	2.28	in/hr
Average Infiltration Rate	3.13	in/hr

BOREHOLE INFILTRATION TEST

1212 South Irving Street Redevelopment
Arlington VA
270060006

BOREHOLE: INF-2

Test Dimensions

Casing Diam: 4 in
Casing Length: 9.75 ft
Pipe Stick-Up: 2 ft
Surface Elevation: 204 ft
Test Elevation: 196.3 ft

Pre-Soak

Initial Soak

Date:	7/1/2020	Date:	7/1/20
Time:	10:05 AM	Time:	1:05 PM
Water Depth:	7.56 ft	Water Depth Below Casing (ft):	7.56
Height of Water:	2.19 ft		

24-Hour Results

Date: 7/2/2020
Time: 7:59 AM
Water Depth: 7.63 ft
Height of Water: 2 ft

Test Information

Date: 7/2/2020
Casing Length: 9.75 ft

Start Time	Time Interval (hour)	Depth to Water from Top of Pipe (ft)	Height of Water in Pipe (ft)	Water Drop in Interval (ft)	Infiltration Rate (ft/h)	Increment Infiltration Rate (in/hr)
Test #1						
8:04 AM	Start	7.25	2.50	-	-	-
8:19 AM	0:15	7.26	2.49	0.01	0.04	0.48
8:34 AM	0:15	7.26	2.49	0.00	0.00	0.00
8:50 AM	0:16	7.26	2.49	0.00	0.00	0.00
9:05 AM	0:15	7.26	2.49	0.00	0.00	0.00
Test #1 Infiltration Rate:						0.01
Test #2						
9:05 AM	Start	7.26	2.49	-	-	-
9:18 AM	0:13	7.26	2.49	0.00	0.00	0.00
9:33 AM	0:15	7.26	2.49	0.00	0.00	0.00
9:49 AM	0:16	7.26	2.49	0.00	0.00	0.00
10:05 AM	0:16	7.27	2.49	0.00	0.02	0.22
Test #2 Infiltration Rate:						0.005
Test #3						
10:05 AM	Start	7.265	2.49	-	-	-
10:20 AM	0:15	7.27	2.49	0.00	0.00	0.00
10:35 AM	0:15	7.27	2.49	0.00	0.00	0.00
10:50 AM	0:15	7.27	2.49	0.00	0.00	0.00
11:07 AM	0:17	7.27	2.49	0.00	0.00	0.00
Test #3 Infiltration Rate:						0.00
Test #4						
11:07 AM	Start	7.265	2.49	-	-	-
11:20 AM	0:13	7.27	2.49	0.00	0.00	0.00
11:33 AM	0:13	7.27	2.49	0.00	0.00	0.00
11:48 AM	0:15	7.27	2.49	0.00	0.00	0.00
12:04 PM	0:16	7.27	2.48	0.00	0.02	0.22
Test #4 Infiltration Rate:						0.005

Notes:

- Water was not added between the 1st and 2nd, 2nd and 3rd, and the 3rd and 4th test due to there being more than 2 ft of water in the pipe.

RESULT		
Lowest Infiltration Rate	0.0	in/hr
Average Infiltration Rate	0.005	in/hr

Appendix C

Laboratory Test Data

SUMMARY OF LABORATORY TESTING

1212 S. IRVING STREET

PROJECT NO. 270060006
SAMPLES: 9
REPORT: 07/10/20

SAMPLE DATE -
LOCATION: *Arlington, VA*
REMARKS: -

JAY KAY TESTING, INC.
 5233 Lehman Road, Suite 110
 Spring Grove, PA 17362
 Phone: (814) 404-9283

BORING	SAMPLE	DEPTH	MC %	OM %	LL	PL	PI	% FINES	USCS
LB-1	S-2	2-4	13.8	-	34	16	18	74.1	CL
LB-1	S-4	6-8	17.3	-	-	-	-	67.9	-
LB-1	S-7	18.5-20	-	-	-	-	-	11.5	-
LB-2	S-8	23.5-25	10.7	-	-	-	-	-	-
LB-2	S-10	33.5-35	31.2	-	-	-	-	-	-
LB-3	S-2	4-6	17.5	-	49	17	32	-	-
LB-3	S-3	8-10	-	-	-	-	-	18.2	-
LB-4	S-1	0-2	-	-	-	-	-	85.3	-
LB-4	S-3	8-10	-	-	-	-	-	18.0	-

Jay Kay Testing, Inc. (AASHTO-Accredited)

1212 S. IRVING STREET

Boring: **LB-1**
 Sample: **S-2**
 Depth: **2-4'**

Project No.: 270060006
 Sample Date: -
 Location: *Arlington, VA*

JAY KAY TESTING, INC.
 5233 Lehman Road, Suite 110
 Spring Grove, PA 17362
 Phone: (814) 404-9283

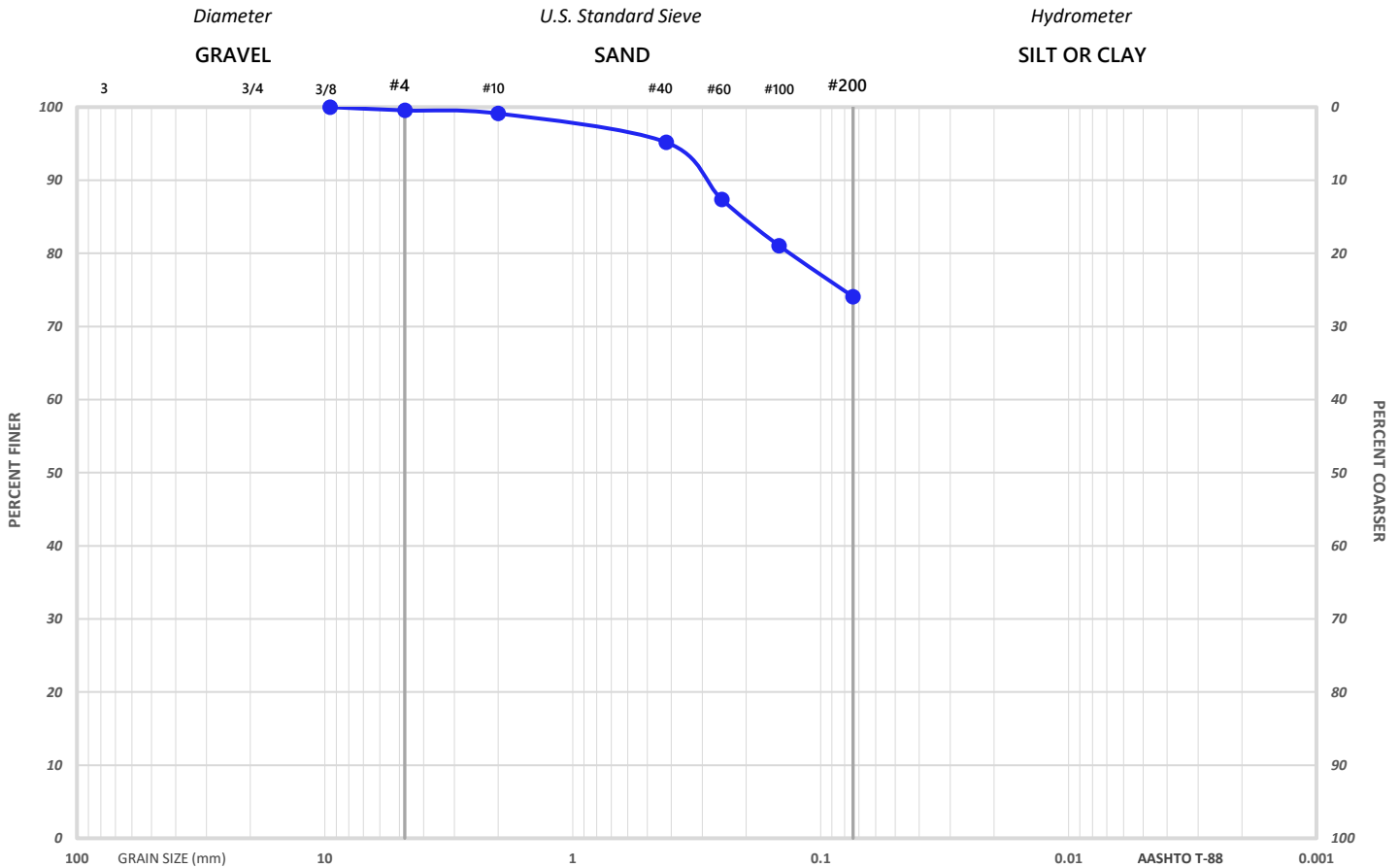

GRAIN SIZE ANALYSIS

<i>Diameter</i>	75.0	50.8	37.5	25.4	19.0	12.7	9.51	4.75	2.0	0.42	0.25	0.147	0.074
<i>Sieve Size</i>	3"	2"	1.5"	1"	3/4"	1/2"	3/8"	#4	#10	#40	#60	#100	#200
<i>% Passing</i>	-	-	-	-	-	-	100.0	99.5	99.1	95.2	87.4	81.1	74.1

% GRAVEL	% SAND	<i>Coarse Gravel</i>	<i>Fine Gravel</i>	<i>Coarse Sand</i>	<i>Medium Sand</i>	<i>Fine Sand</i>	CC	CU
0.5	25.4	-	0.5	0.4	3.9	21.1	-	-

Moisture Content: 13.8
 pH: -
 Organic Content: -
 Other: -

ATTERBERG LIMITS

Liquid Limit	34
Plastic Limit	16
Plasticity Index	18

CLASSIFICATION

AASHTO	A-6
USCS	CL

SOIL DESCRIPTION

Light brown lean CLAY with sand

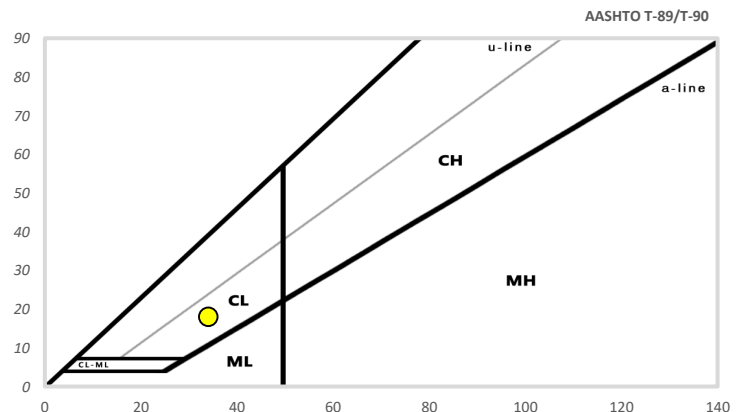

1212 S. IRVING STREET

Boring: **LB-1**
 Sample: **S-4**
 Depth: **6-8'**

Project No.: 270060006
 Sample Date: -
 Location: *Arlington, VA*

JAY KAY TESTING, INC.
 5233 Lehman Road, Suite 110
 Spring Grove, PA 17362
 Phone: (814) 404-9283

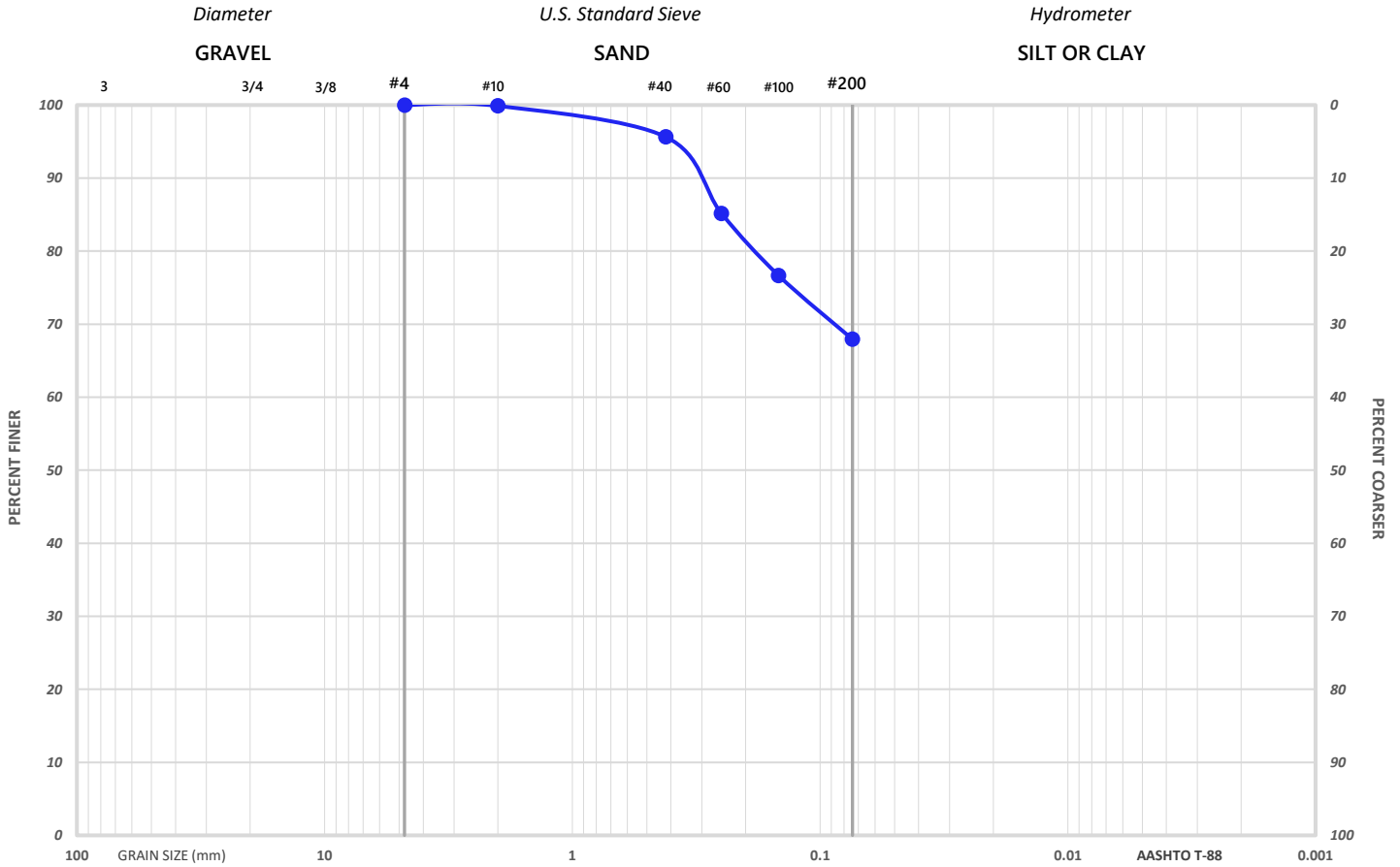

GRAIN SIZE ANALYSIS

<i>Diameter</i>	75.0	50.8	37.5	25.4	19.0	12.7	9.51	4.75	2.0	0.42	0.25	0.147	0.074
<i>Sieve Size</i>	3"	2"	1.5"	1"	3/4"	1/2"	3/8"	#4	#10	#40	#60	#100	# 200
<i>% Passing</i>	-	-	-	-	-	-	-	100.0	99.9	95.6	85.2	76.7	67.9

% GRAVEL	% SAND	<i>Coarse Gravel</i>	<i>Fine Gravel</i>	<i>Coarse Sand</i>	<i>Medium Sand</i>	<i>Fine Sand</i>	CC	CU
-	32.1	-	-	0.1	4.3	27.7	-	-

Moisture Content	17.3	Organic Content	-
pH	-	Other	-

ATTERBERG LIMITS		CLASSIFICATION	
Liquid Limit	-	AASHTO	-
Plastic Limit	-	USCS	-
Plasticity Index	-		

VISUAL SOIL DESCRIPTION
 Light gray clay

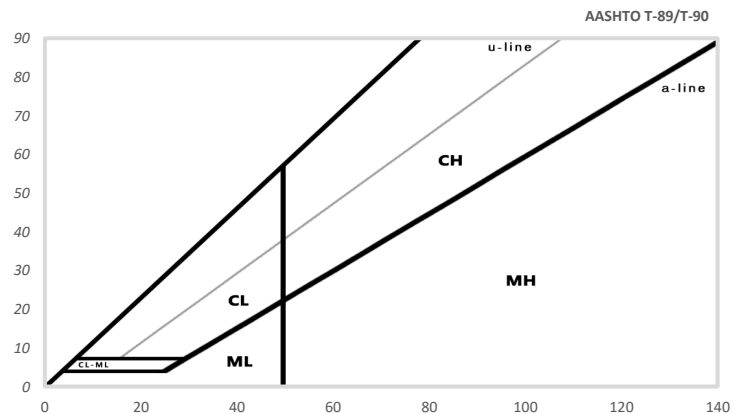

1212 S. IRVING STREET

Boring: **LB-1**
 Sample: **S-7**
 Depth: **18.5-20'**

Project No.: 270060006
 Sample Date: -
 Location: *Arlington, VA*

JAY KAY TESTING, INC.
 5233 Lehman Road, Suite 110
 Spring Grove, PA 17362
 Phone: (814) 404-9283

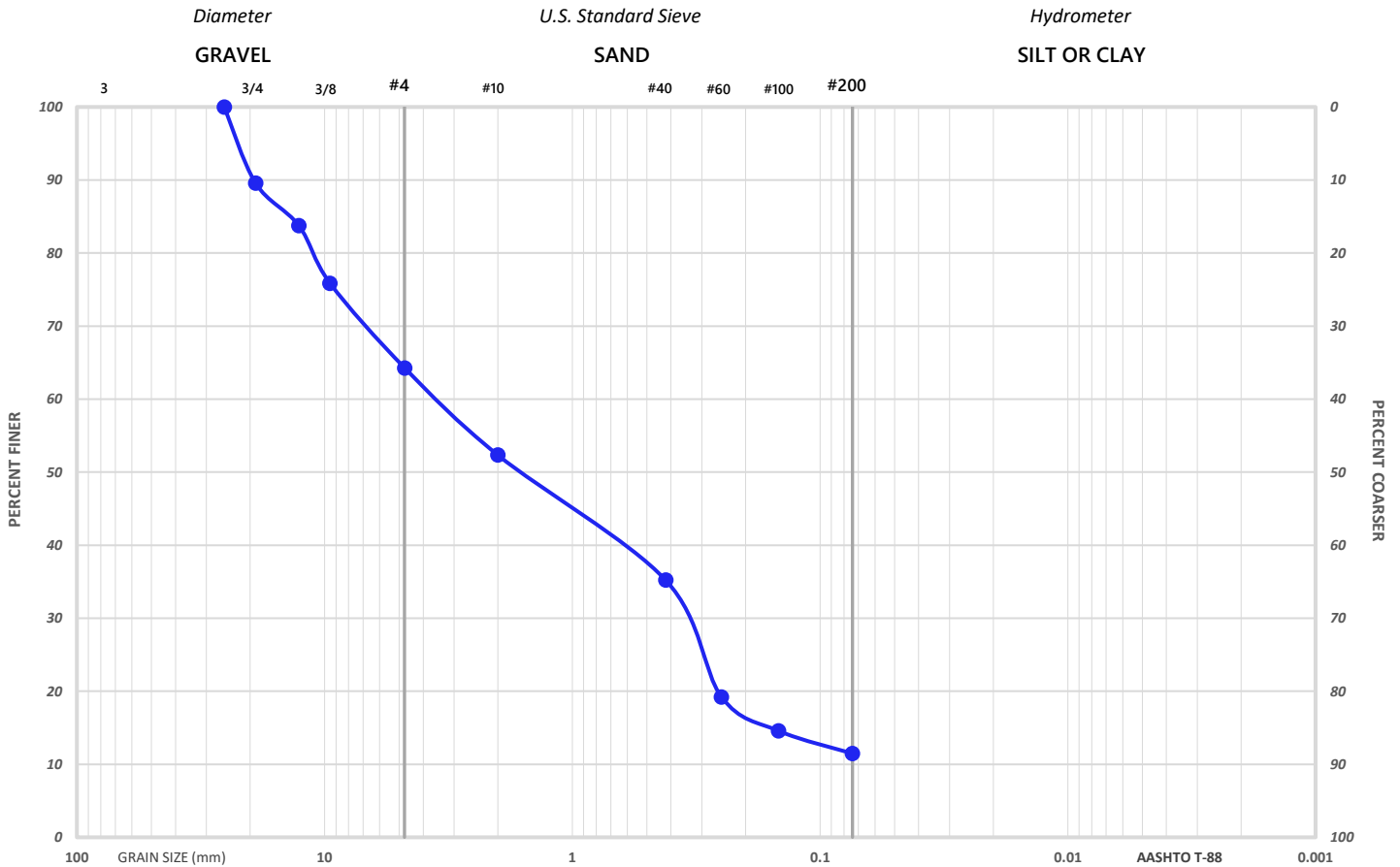

GRAIN SIZE ANALYSIS

<i>Diameter</i>	75.0	50.8	37.5	25.4	19.0	12.7	9.51	4.75	2.0	0.42	0.25	0.147	0.074
<i>Sieve Size</i>	3"	2"	1.5"	1"	3/4"	1/2"	3/8"	#4	#10	#40	#60	#100	# 200
<i>% Passing</i>	-	-	-	100.0	89.6	83.7	75.9	64.3	52.3	35.2	19.2	14.6	11.5

% GRAVEL	% SAND	<i>Coarse Gravel</i>	<i>Fine Gravel</i>	<i>Coarse Sand</i>	<i>Medium Sand</i>	<i>Fine Sand</i>	CC	CU
35.7	52.8	10.4	25.3	12.0	17.1	23.7	0.58	68.57

Moisture Content - Organic Content -
 pH - Other -

ATTERBERG LIMITS

Liquid Limit -
 Plastic Limit -
 Plasticity Index -

CLASSIFICATION

AASHTO -
 USCS -

VISUAL SOIL DESCRIPTION

Gray poorly graded SAND with silt and gravel

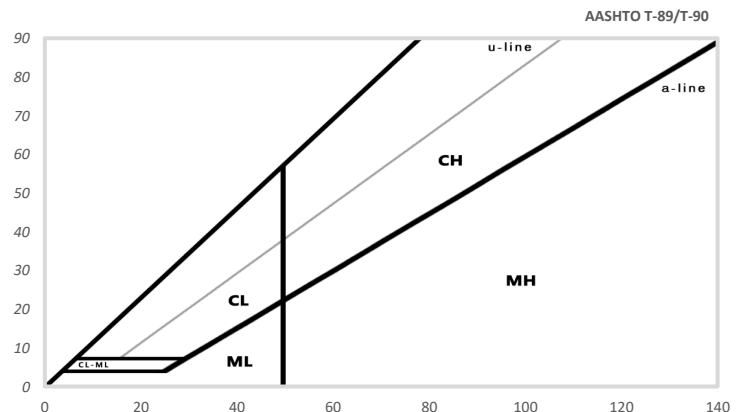

1212 S. IRVING STREET

Boring: **LB-3**
 Sample: **S-3**
 Depth: **8-10'**

Project No.: 270060006
 Sample Date: -
 Location: *Arlington, VA*

JAY KAY TESTING, INC.
 5233 Lehman Road, Suite 110
 Spring Grove, PA 17362
 Phone: (814) 404-9283

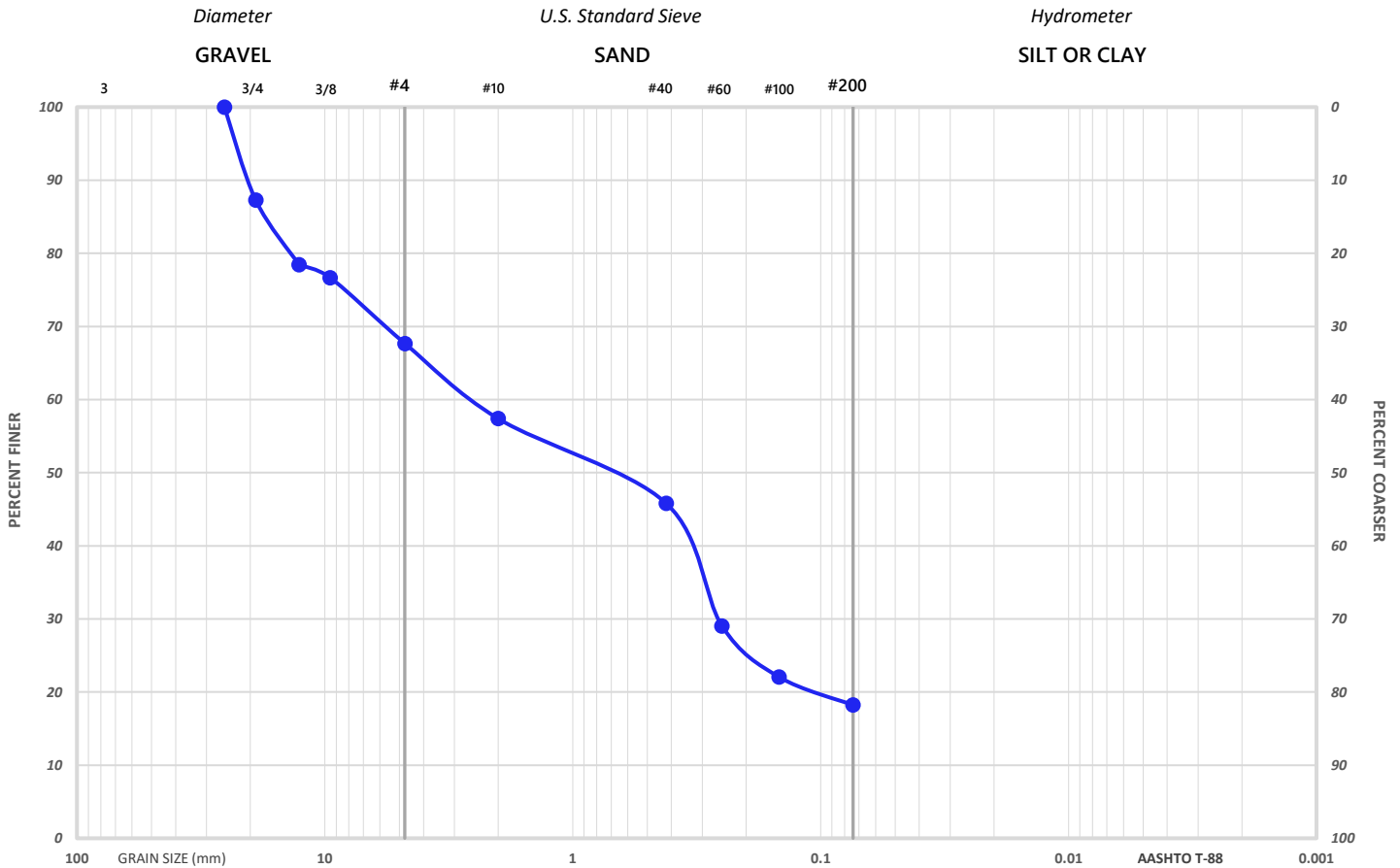

GRAIN SIZE ANALYSIS

<i>Diameter</i>	75.0	50.8	37.5	25.4	19.0	12.7	9.51	4.75	2.0	0.42	0.25	0.147	0.074
<i>Sieve Size</i>	3"	2"	1.5"	1"	3/4"	1/2"	3/8"	#4	#10	#40	#60	#100	# 200
<i>% Passing</i>	-	-	-	100.0	87.3	78.4	76.7	67.7	57.4	45.8	29.0	22.0	18.2

% GRAVEL	% SAND	<i>Coarse Gravel</i>	<i>Fine Gravel</i>	<i>Coarse Sand</i>	<i>Medium Sand</i>	<i>Fine Sand</i>	CC	CU
32.3	49.5	12.7	19.6	10.3	11.6	27.6	-	-

Moisture Content - Organic Content -
 pH - Other -

ATTERBERG LIMITS

Liquid Limit -
 Plastic Limit -
 Plasticity Index -

CLASSIFICATION

AASHTO -
 USCS -

VISUAL SOIL DESCRIPTION

Light brown silty SAND with gravel

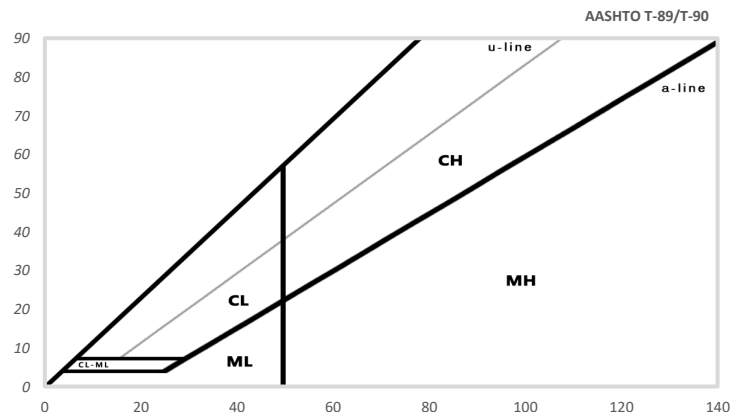

1212 S. IRVING STREET

Boring: **LB-4**
 Sample: **S-1**
 Depth: **0-2'**

Project No.: 270060006
 Sample Date: -
 Location: *Arlington, VA*

JAY KAY TESTING, INC.
 5233 Lehman Road, Suite 110
 Spring Grove, PA 17362
 Phone: (814) 404-9283

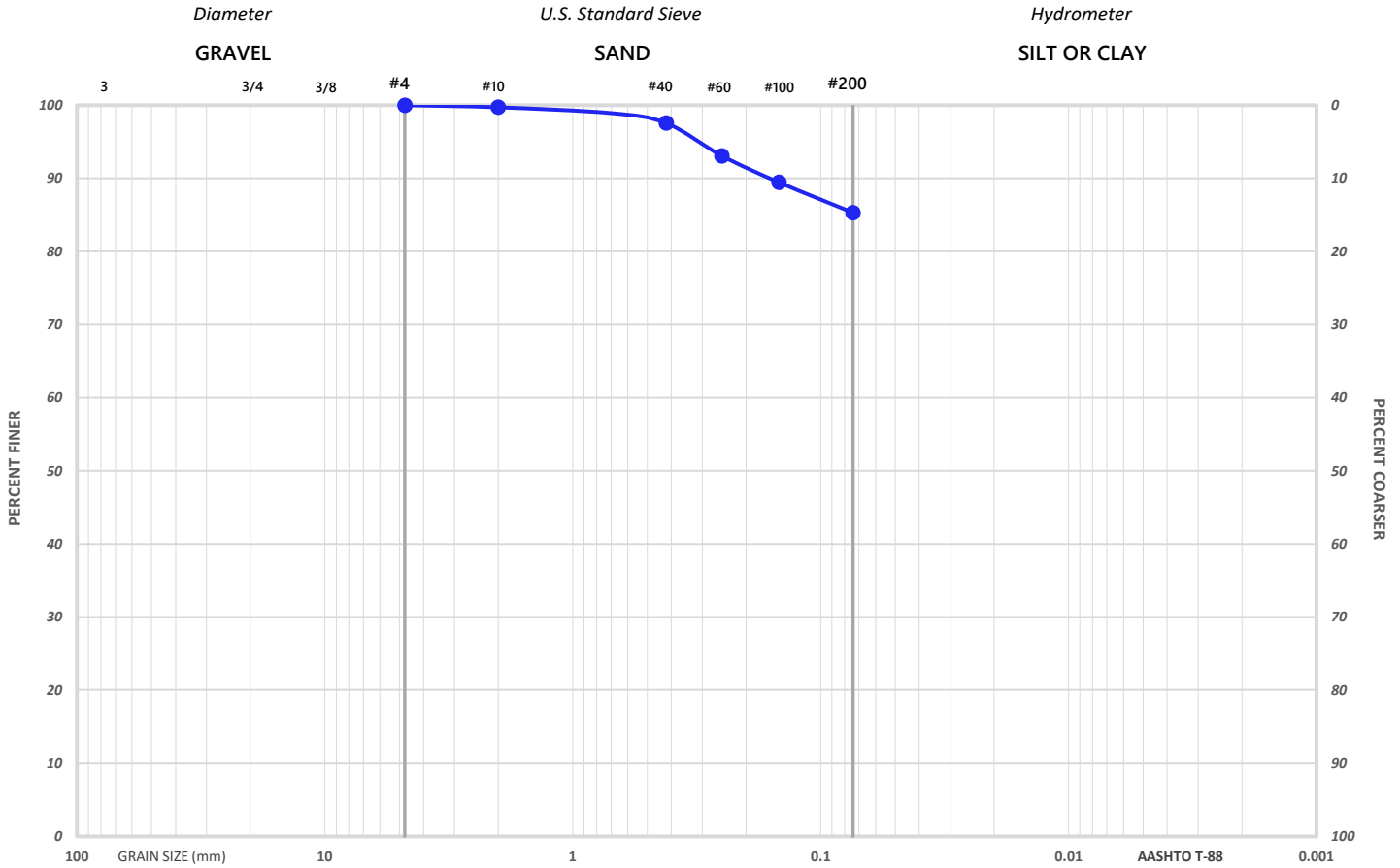

GRAIN SIZE ANALYSIS

<i>Diameter</i>	75.0	50.8	37.5	25.4	19.0	12.7	9.51	4.75	2.0	0.42	0.25	0.147	0.074
<i>Sieve Size</i>	3"	2"	1.5"	1"	3/4"	1/2"	3/8"	#4	#10	#40	#60	#100	# 200
<i>% Passing</i>	-	-	-	-	-	-	-	100.0	99.7	97.5	93.1	89.4	85.3

% GRAVEL	% SAND	<i>Coarse Gravel</i>	<i>Fine Gravel</i>	<i>Coarse Sand</i>	<i>Medium Sand</i>	<i>Fine Sand</i>	CC	CU
-	14.7	-	-	0.3	2.2	12.2	-	-

Moisture Content - Organic Content -
 pH - Other -

ATTERBERG LIMITS

Liquid Limit -
 Plastic Limit -
 Plasticity Index -

CLASSIFICATION

AASHTO -
 USCS -

VISUAL SOIL DESCRIPTION

Light brown silt

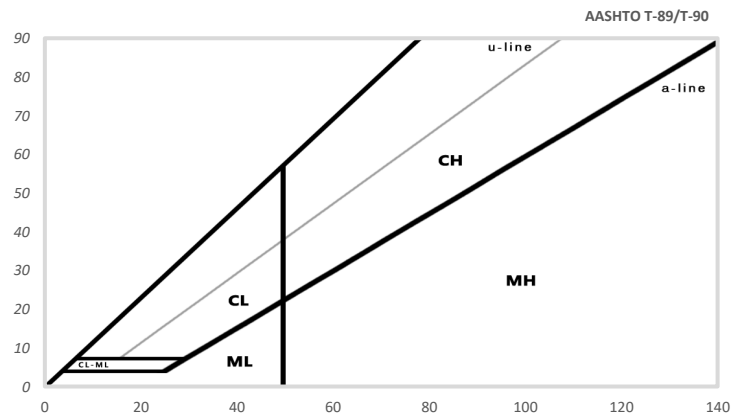

1212 S. IRVING STREET

Boring: **LB-4**
 Sample: **S-3**
 Depth: **8-10'**

Project No.: 270060006
 Sample Date: -
 Location: *Arlington, VA*

JAY KAY TESTING, INC.
 5233 Lehman Road, Suite 110
 Spring Grove, PA 17362
 Phone: (814) 404-9283

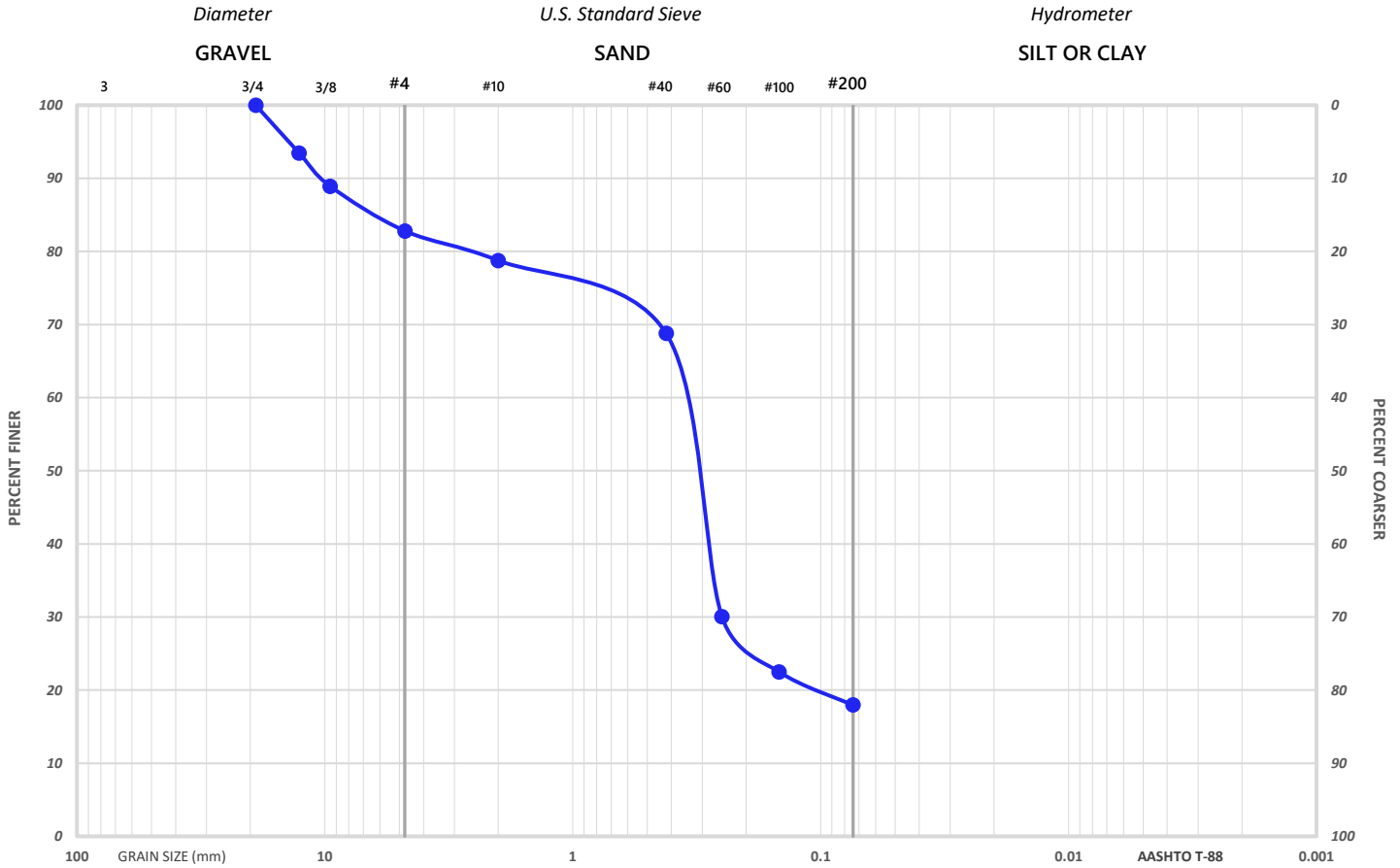

GRAIN SIZE ANALYSIS

<i>Diameter</i>	75.0	50.8	37.5	25.4	19.0	12.7	9.51	4.75	2.0	0.42	0.25	0.147	0.074
<i>Sieve Size</i>	3"	2"	1.5"	1"	3/4"	1/2"	3/8"	#4	#10	#40	#60	#100	# 200
<i>% Passing</i>	-	-	-	-	100.0	93.5	88.9	82.8	78.8	68.8	30.0	22.5	18.0

% GRAVEL	% SAND	<i>Coarse Gravel</i>	<i>Fine Gravel</i>	<i>Coarse Sand</i>	<i>Medium Sand</i>	<i>Fine Sand</i>	CC	CU
17.2	64.8	-	17.2	4.0	10.0	50.8	-	-

Moisture Content - Organic Content -
 pH - Other -

ATTERBERG LIMITS

Liquid Limit -
 Plastic Limit -
 Plasticity Index -

CLASSIFICATION

AASHTO -
 USCS -

VISUAL SOIL DESCRIPTION

Light brown clayey SAND with gravel

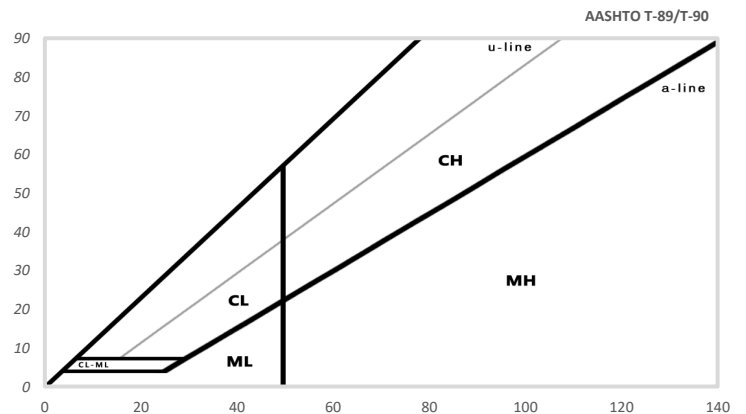

SECTION 024116 - STRUCTURE DEMOLITION

PART 1 - GENERAL

1.1 SUMMARY

A. Section Includes:

1. Demolition and removal of buildings and site improvements.
2. Removing below-grade construction.
3. Disconnecting, capping or sealing, and removing site utilities.

1.2 MATERIALS OWNERSHIP

- A. Unless otherwise indicated, demolition waste becomes property of Contractor.
- B. Historic items, relics, antiques, and similar objects including, but not limited to, cornerstones and their contents, commemorative plaques and tablets, and other items of interest or value to Owner that may be uncovered during demolition remain the property of Owner.
 1. Carefully salvage in a manner to prevent damage and promptly return to Owner.

1.3 PREINSTALLATION MEETINGS

- A. Predemolition Conference: Conduct conference at Project site.

1.4 INFORMATIONAL SUBMITTALS

- A. Engineering Survey: Submit engineering survey of condition of building.
- B. Proposed Protection Measures: Submit report, including Drawings, that indicates the measures proposed for protecting individuals and property, for environmental protection, for dust control and for noise control. Indicate proposed locations and construction of barriers.
 1. Adjacent Buildings: Detail special measures proposed to protect adjacent buildings to remain including means of egress from those buildings.
- C. Schedule of building demolition activities with starting and ending dates for each activity.
- D. Predemolition photographs or video.
- E. Statement of Refrigerant Recovery: Signed by refrigerant recovery technician.

1.5 QUALITY ASSURANCE

- A. Refrigerant Recovery Technician Qualifications: Certified by EPA-approved certification program.

1.6 FIELD CONDITIONS

- A. Buildings to be demolished will be vacated and their use discontinued before start of the Work.
- B. Buildings immediately adjacent to demolition area will be occupied. Conduct building demolition so operations of occupied buildings will not be disrupted.
 - 1. Provide not less than 72 hours' notice of activities that will affect operations of adjacent occupied buildings.
 - 2. Maintain access to existing walkways, exits, and other facilities used by occupants of adjacent buildings.
 - a. Do not close or obstruct walkways, exits, or other facilities used by occupants of adjacent buildings without written permission from authorities having jurisdiction.
- C. Conditions existing at time of inspection for bidding purpose will be maintained by Owner as far as practical.
- D. Hazardous Materials: It is not expected that hazardous materials will be encountered in the Work.
 - 1. Hazardous materials will be removed by Owner before start of the Work.
 - 2. If materials suspected of containing hazardous materials are encountered, do not disturb; immediately notify Architect and Owner. Hazardous materials will be removed by Owner under a separate contract.
- E. On-site storage or sale of removed items or materials is not permitted.

PART 2 - PRODUCTS

2.1 PERFORMANCE REQUIREMENTS

- A. Regulatory Requirements: Comply with governing EPA notification regulations before beginning demolition. Comply with hauling and disposal regulations of authorities having jurisdiction.
- B. Standards: Comply with ANSI/ASSE A10.6 and NFPA 241.

2.2 SOIL MATERIALS

- A. Satisfactory Soils: Comply with requirements in Section 312000 "Earth Moving."

PART 3 - EXECUTION

3.1 EXAMINATION

- A. Verify that utilities have been disconnected and capped before starting demolition operations.
- B. Perform an engineering survey of condition of building to determine whether removing any element might result in structural deficiency or unplanned collapse of any portion of structure or adjacent structures during building demolition operations.
- C. Inventory and record the condition of items to be removed and salvaged.

3.2 PREPARATION

- A. Refrigerant: Before starting demolition, remove refrigerant from mechanical equipment according to 40 CFR 82 and regulations of authorities having jurisdiction.

3.3 UTILITY SERVICES AND MECHANICAL/ELECTRICAL SYSTEMS

- A. Existing Utilities to be Disconnected: Locate, identify, disconnect, and seal or cap off utilities serving buildings and structures to be demolished.
 - 1. Arrange to shut off utilities with utility companies.
 - 2. If removal, relocation, or abandonment of utility services will affect adjacent occupied buildings, then provide temporary utilities that bypass buildings and structures to be demolished and that maintain continuity of service to other buildings and structures.
 - 3. Cut off pipe or conduit a minimum of 24 inches (610 mm) below grade. Cap, valve, or plug and seal remaining portion of pipe or conduit after bypassing according to requirements of authorities having jurisdiction.
 - 4. Do not start demolition work until utility disconnecting and sealing have been completed and verified in writing.

3.4 PROTECTION

- A. Existing Facilities: Protect adjacent walkways, building entries, and other building facilities during demolition operations. Maintain exits from existing buildings.
- B. Temporary Shoring: Provide and maintain interior and exterior shoring, bracing, or structural support to preserve stability and prevent unexpected movement or collapse of construction being demolished.
- C. Existing Utilities to Remain: Maintain utility services to remain and protect from damage during demolition operations. Do not interrupt existing utilities serving adjacent occupied facilities unless authorized in writing by Owner and authorities having jurisdiction.

- D. Temporary Protection: Erect temporary protection, such as walks, fences, railings, canopies, and covered passageways, where required by authorities having jurisdiction and as indicated. Comply with requirements in Section 015000 "Temporary Facilities and Controls."
1. Protect adjacent buildings and facilities from damage due to demolition activities.
 2. Protect existing site improvements, appurtenances, and landscaping to remain.
 3. Erect a plainly visible fence around drip line of individual trees or around perimeter drip line of groups of trees to remain.
 4. Provide temporary barricades and other protection required to prevent injury to people and damage to adjacent buildings and facilities to remain.
 5. Provide protection to ensure safe passage of people around building demolition area and to and from occupied portions of adjacent buildings and structures.
- E. Remove temporary barriers and protections where hazards no longer exist. Where open excavations or other hazardous conditions remain, leave temporary barriers and protections in place.

3.5 DEMOLITION

- A. General: Demolish indicated buildings and site improvements completely. Use methods required to complete the Work within limitations of governing regulations and as follows:
1. Do not use cutting torches until work area is cleared of flammable materials. Maintain portable fire-suppression devices during flame-cutting operations.
 2. Maintain fire watch during and for at least 2 hours after flame-cutting operations.
 3. Maintain adequate ventilation when using cutting torches.
- B. Site Access and Temporary Controls: Conduct building demolition and debris-removal operations to ensure minimum interference with roads, streets, walks, walkways, and other adjacent occupied and used facilities.
1. Do not close or obstruct streets, walks, walkways, or other adjacent occupied or used facilities without permission from Owner and authorities having jurisdiction. Provide alternate routes around closed or obstructed trafficways if required by authorities having jurisdiction.
 2. Use water mist and other suitable methods to limit spread of dust and dirt. Comply with governing environmental-protection regulations.
- C. Explosives: Use of explosives is not permitted.
- D. Proceed with demolition of structural framing members systematically, from higher to lower level. Complete building demolition operations above each floor before disturbing supporting members on the next lower level.
- E. Demolish foundation walls and other below-grade construction.
1. Remove below-grade construction, including basements, foundation walls, and footings, completely.

- F. Existing Utilities: Demolish existing utilities and below-grade utility structures that are within the property boundaries unless shown otherwise. Abandon utilities outside this area.
- G. Below-Grade Areas: Completely fill below-grade areas and voids resulting from building demolition operations with **satisfactory soil materials** according to backfill requirements in Section 312000 "Earth Moving."
- H. Site Grading: Uniformly rough grade area of demolished construction to a smooth surface, free from irregular surface changes. Provide a smooth transition between adjacent existing grades and new grades.
- I. Promptly repair damage to adjacent buildings caused by demolition operations.

3.6 CLEANING

- A. Remove demolition waste materials from Project site and dispose of them in an EPA-approved construction and demolition waste landfill acceptable to authorities having jurisdiction or recycle or dispose of them according to Section 017419 "Construction Waste Management and Disposal."
- B. Do not burn demolished materials.
- C. Clean adjacent structures and improvements of dust, dirt, and debris caused by building demolition operations. Return adjacent areas to condition existing before building demolition operations began.

END OF SECTION 024116

THIS PAGE INTENSIONALLY LEFT BLANK

SECTION 031119 – INSULATING CONCRETE FORMING

PART 1 - GENERAL

1.1 SUMMARY

A. Section Includes:

1. Permanent insulating forming system for cast-in-place concrete.

B. Refer to the following for related section:

1. Section 071326, “Self-Adhering Sheet Waterproofing” for Expanded Polystyrene (EPS) foam compatible foundation waterproofing.

1.2 DEFINITIONS

- A. Wall Alignment System - bracing that acts as an alignment/scaffold system designed for use with insulating concrete forming (ICF).
- B. Formwork: The total system of support of freshly placed concrete, including the mold or sheathing that contacts the concrete, as well as supporting members, hardware, and necessary bracing.
- C. Service Penetrations – services such as electrical wiring, pipes, ventilation systems.that are installed in or through the ICF walls.

1.3 PREINSTALLATION MEETINGS

- A. Preinstallation Conference: Conduct conference at Project site. The Installing Contractor shall meet with the Contractor and relevant trades, as required, to coordinate the delivery, storage and handling of ICF including components.

1.4 ACTION SUBMITTALS

- A. Product Data: Manufacturer’s Product, Design and Installation Manual.
- B. Shop Drawings: Prepared by, and signed and sealed by, a qualified professional engineer responsible for their preparation, detailing fabrication, assembly, and support of forms.
 1. Product drawings showing dimensions, wall section course heights, layout, form types and details.

1.5 INFORMATIONAL SUBMITTALS

- A. Qualification Data: For testing and inspection agency.
- B. Research Reports: For insulating concrete forms indicating compliance with International Code Council Acceptance Criteria AC308.
- C. Laboratory tests or data that validate product compliance with performance criteria specified.
- D. Relevant code compliance certificates including standards and evaluations.
- E. Field quality-control reports.
- F. Minutes of preinstallation conference.

1.6 QUALITY ASSURANCE

- A. Testing and Inspection Agency Qualifications: An independent agency, acceptable to authorities having jurisdiction, qualified in accordance with ASTM C1077 and ASTM E329 for testing indicated.
- B. Installing Contractor shall be ICF trained and experienced.
- C. Installers of ICF shall provide proof of training documentation to contractor.
- D. An ICF Technical Representative shall be available to supervise construction on a regular basis.
- E. Installation of ICF shall comply with ACI 347.

1.7 DELIVERY, STORAGE, AND HANDLING

- B. LOGIX ICF shall be delivered on-site in original factory packaging. All delivered ICF products shall show traceability by bearing on the identification label the location of manufacturing plant, product description, batch/lot number and date produced.
- C. Care shall be exercised in handling and unloading ICF onto the construction site to minimize damage to the EPS boards and/or webs. ICF shall remain in original factory packaging until ready for installation.
- D. Storage location shall be in an area that will minimize damage or soiling to ICF products. Protection shall be provided in cases where stored products of ICF could be exposed, for more than 2 weeks, to UV or freezing rain or snow conditions

PART 2 - PRODUCTS

2.1 SYSTEM DISCRIPTION

- A. ICF shall consist of two flame-resistant Expanded Polystyrene (EPS) boards separated by polypropylene webs. The EPS boards shall be manufactured using *BASF Neopor bead resins* or *BASF bead resins*.
- B. ICF shall be solid form units or knock-down forms or a combination of both referred as Hybrid Forms.
- C. The EPS foam boards shall be minimum 2.75 inch (70 mm) thick, which gives a total EPS foam board thickness of 5.50 inches (140 mm).
- D. The webs shall separate the EPS boards to form 4 inch (102 mm), 6.25 inch (159 mm), 8 inch (203 mm), 10 inch (254mm) and 12 inch (305mm) cavities, which create the concrete wall thicknesses. .
- E. The volume of webs within the concrete wall component shall be no more than 0.25%.
- F. The webs shall be spaced minimum every 8 inch (203 mm) on center horizontally and 16 inch (406 mm) on center vertically, and contain a 1.25 inch (32 mm) wide furring strip that extends the height of each ICF block. The furring strips shall facilitate fasteners for attachment of both exterior and interior finishes.
- G. A furring strip shall be located in the corners of corner forms. The furring strip shall consist of both a vertical and horizontal component. The vertical component shall extend nearly the full height of the form, extend a minimum of 2.5 inches (64 mm) from both sides of the corner, and a minimum of 0.2 inches (5 mm) thick. The horizontal component shall be minimum 2 inches (51mm) in height, extend a minimum of 6 inches (152 mm) from both sides of the corner, and a minimum of 0.2 inches (5 mm) thick.
- H. The webs facilitate rebar placement in accordance with ACI 318.
- I. Design/Performance Requirements
 - 1. Minimum thermal resistance of LOGIX Platinum EPS form panels shall be R4.71
 - 2. Fasteners to be used for attachment of exterior cladding to ICF shall demonstrate, by either testing or engineering principles, resistance to design wind loads.
 - 3. Compliance to ASTM E2634, "Standard Specification for Flat Wall Insulating Concrete Forms."

2.2 MANUFACTURER

- A. Insulating concrete forming products and accessories shall be manufactured by LOGIX ICF.

2.3 MATERIALS

- A. Insulating concrete forms shall be made with *{BASF Neopor EPS for Logix Platinum}* or *{BASF EPS for Logix PRO}*. Web ties and furring tabs shall be made with polypropylene plastic meeting the requirements herein.

2.4 CONCRETE & REINFORCING STEEL

- A. Concrete slump shall be 5 to 7 inch (127 to 178 mm). Slump may differ depending on design revisions to suit application.
- B. Reinforcing steel shall be as specified under Section 033000, and as shown on the drawings.
- C. Structural design of reinforced concrete shall comply with ACI 318 & 301 as applicable.

2.5 WALL ALIGNMENT AND SCAFFOLDING SYSTEM

- A. The Wall Alignment and Scaffolding System shall be used as a wall bracing system, and consist of an adjustable mechanism to ensure, and maintain, plumbness of the wall during construction. Installation of LOGIX ICF shall comply with ACI 347R.
- B. Assembly of the wall alignment and scaffolding system shall comply with local building and regulatory codes.
- C. The wall alignment and scaffolding system shall be assembled to handle all design construction loads, and must be approved by the qualified professional engineer who prepared the submittal drawings.
- D. The wall alignment and scaffolding system shall demonstrate resistance to the following design load conditions:
 - 1. Design wind load of 90 mph unoccupied, and 35 mph occupied, in accordance with ASCE 7-98 “Minimum Design Loads for Buildings and Other Structures”, and the “Tilt-up Concrete Association’s Guideline for Temporary Wind Bracing of Tilt-up Concrete Panels During Construction.”
 - 2. Light-duty loading of 25 psf, as specified by OSHA.
 - 3. Horizontal loading of 200 lb applied at the top rail to simulate a worker leaning against the guardrail.
- E. Where called for on drawings, waterproofing shall be an EPS compatible waterproofing system approved by the ICF manufacturer.

PART 3 - EXECUTION

3.1 VERIFICATION

- A. Installer will verify the following site conditions prior to installation of ICF.

1. Footings installed under Section 033000 are within +/- ¼ inch (6 mm) of level and that steps in footings are 16 inches (406 mm) in height.
2. Reinforcing steel dowels are in place at specified centers along footing lengths.

3.2 PREPARATION

- A. The Installing Contractor will ensure top of footings are clear of debris prior to installing ICF. All debris must be removed from the interior of the forms prior to installation.

3.3 INSTALLATION

- A. Retighten forms and bracing before placing concrete, as required, to prevent mortar leaks and maintain proper alignment.
- B. Installation of ICF will be in conformance to the manufacturer's Installation Manual complying with the manufacturer's installation instructions or as per the manufacturer's Technical Advisor's recommendations.
- C. The installation will ensure the proper installation methods for the following work are employed on site:
 1. Installation of First Course
 2. Installation of Horizontal Reinforcement
 3. Setting Successive Courses
 4. Forming Door & Window Openings
 5. ICF Alignment & Scaffolding System Installation
 6. Installation of Vertical Reinforcement
 7. Inspection and alignment of forms Prior to Concrete Placement
 8. Concrete Placement
 9. ICF Alignment & Scaffolding System Removal

3.3 INSTALLATION OF SERVICE PENETRATIONS AND EMBEDDED ITEMS

- A. Where service penetrations run through the ICF wall, sleeves will be provided to create a void where the service is to be located. Sleeves will be placed prior to concrete placement
- B. Place and secure anchorage devices and other embedded items required for adjoining work that is attached to or supported by cast-in-place concrete.
 1. Use setting drawings, templates, diagrams, instructions, and directions furnished with items to be embedded.
 2. Install anchor rods, accurately located, to elevations required and complying with tolerances in Section 7.5 of AISC 303.
 3. Clean embedded items immediately prior to concrete placement.

3.4 CONCRETE PLACEMENT

- A. Concrete placement will not exceed a pour rate of 4 ft/hr.
- B. Maximum pour height will not exceed 14 ft. In addition, Logix ICF shall demonstrate resistance to the lateral concrete pressure exerted from placing concrete in a 14 ft tall wall, per ACI 347, "Guide to Formwork for Concrete".

3.5 FIELD QUALITY CONTROL

- A. Special Inspections: Owner will engage a special inspector to perform field tests and inspections and prepare test reports.
- B. Testing Agency: Engage a qualified testing and inspecting agency to perform tests and inspections and to submit reports.
- C. Inspections:
 - 1. Inspect insulating concrete forms for shape, location, and dimensions of the concrete wall being formed and the following:
 - a. Conformance to design drawings;
 - b. Plumbness of wall;
 - c. Rebar placement;
 - d. Stability of wall alignment system (wall bracing system) and any additional anchoring system required to keep the walls aligned position and rigidity

3.6 PROTECTION

- A. Prior to concrete placement, interlocking knobs along the top of the ICF wall will be protected with tape or other means to ensure no concrete debris sets on and between the interlocking knobs.
- B. Protection of installed forms will be provided if the forms are expected to be exposed to UV rays for longer than 180 days.

END OF SECTION 031000

SECTION 033000 – CAST-IN-PLACE CONCRETE

PART 1 - GENERAL

1.01 SUMMARY

- A. This Section specifies cast-in-place concrete, including reinforcement, concrete materials, mix design, placement procedures, and finishes.
- B. Refer to Section 321316, “Decorative Concrete Paving” for stamped and stained concrete paved, porch floor and site patio.

1.02 PREINSTALLATION MEETING

- A. Preinstallation Conference: Conduct conference at Project site.

1.03 SUBMITTALS

- A. General: In addition to the following, comply with submittal requirements in ACI 301.
- B. Product Data: For each type of manufactured material and product indicated.
- C. Design Mixes: For each concrete mix.

1.04 QUALITY ASSURANCE

- A. Installer Qualifications: An experienced installer who has completed concrete work similar in material, design, and extent to that indicated for this Project and whose work has resulted in construction with a record of successful in-service performance.
- B. Manufacturer Qualifications: A firm experienced in manufacturing ready-mixed concrete products complying with ASTM C 94 requirements for production facilities and equipment.
- C. Source Limitations: Obtain each type of cement of the same brand from the same manufacturer's plant, each aggregate from one source, and each admixture from the same manufacturer.
- D. Comply with ACI 301, "Specification for Structural Concrete," including the following, unless modified by the requirements of the Contract Documents.
 - 1. Formwork and form accessories.
 - 2. Steel reinforcement and supports.
 - 3. Concrete mixtures.

PART 2 - PRODUCTS

2.01 FORMWORK

- A. Furnish formwork and form accessories according to ACI 301.
- B. Refer to Section 031119, "Insulating Concrete Forming" for foundation wall forms.

2.02 STEEL REINFORCEMENT

- A. Reinforcing Bars: ASTM A 615/A 615M, Grade 60, deformed.
- B. Plain-Steel Wire: ASTM A 82, as drawn.
- C. Plain-Steel Welded Wire Fabric: ASTM A 185, fabricated from as-drawn steel wire into flat sheets.

2.03 CONCRETE MATERIALS

- A. Portland Cement: ASTM C 150, Types I or II or Type I/II.
- B. Normal-Weight Aggregate: ASTM C 33, uniformly graded, not exceeding 1½ inch nominal size.
- C. Lightweight Aggregate: ASTM C 330.
- D. Water: Potable and complying with ASTM C 94.

2.04 ADMIXTURES

- A. General: Admixtures certified by manufacturer to contain not more than 0.1 percent water-soluble chloride ions by mass of cement and to be compatible with other admixtures. Do not use admixtures containing calcium chloride.
- B. Air-Entraining Admixture: ASTM C 260.
- C. Water-Reducing Admixture: ASTM C 494, Type A.
- D. High-Range, Water-Reducing Admixture: ASTM C 494, Type F.
- E. Water-Reducing and Accelerating Admixture: ASTM C 494, Type E.
- F. Water-Reducing and Retarding Admixture: ASTM C 494, Type D.

2.05 RELATED MATERIALS

- A. Vapor Retarder: Refer to Section 072600 "Vapor Retarders" for products and requirements.
- B. Joint-Filler Strips: ASTM D 1751, asphalt-saturated cellulosic fiber, or ASTM D 1752, cork or self-expanding cork.
- C. Safety Treads: Provide Spectra type WP24 safety nosings as manufactured by Wooster Products, Inc. for exterior stair treads. Color of aluminum oxide abrasive grit to be selected by architect from manufacturer's standard offering.

2.06 CURING MATERIALS

- A. Evaporation Retarder: Waterborne, monomolecular film forming, manufactured for application to fresh concrete.
- B. Absorptive Cover: AASHTO M 182, Class 2, burlap cloth made from jute or kenaf, weighing approximately 9 oz./sq. yd. dry.
- C. Moisture-Retaining Cover: ASTM C 171, polyethylene film or white burlap-polyethylene sheet.
- D. Water: Potable.
- E. Water Based, Membrane-Forming Acrylic Curing and Sealing Compound: ASTM C 309, Type 1, Classes A and B.
 - 1. Manufacturer: The Euclid Chemical Co., Eucocure VOX or approved equivalent.

2.07 CONCRETE MIXES

- A. Comply with ACI 301 requirements for concrete mixtures.
- B. Prepare design mixes, proportioned according to ACI 301, for normal-weight concrete determined by either laboratory trial mix or field test data bases, as follows:
 - 1. Compressive Strength (28 Days): As indicated on the structural drawings.
 - 2. Slump: 5 inches, plus or minus 1.
 - a. Slump Limit for Concrete Containing High-Range Water-Reducing Admixture: Not more than 8 inches after adding admixture to plant- or site-verified, 2 to 3 inch slump.
- C. Add air-entraining admixture at manufacturer's prescribed rate to result in concrete at point of placement having an air content of 6.0 percent within a tolerance of plus 1.0 or minus 1.5 percent.
 - 1. Air content of trowel-finished interior concrete floors shall not exceed 3.0 percent.

2.08 CONCRETE MIXING

- A. Ready-Mixed Concrete: Comply with ASTM C 94.

- B. Ready-Mixed Concrete: Comply with ASTM C 94 and ASTM C 1116.
 - 1. When air temperature is between 85 and 90 degrees F, reduce mixing and delivery time from 1-1/2 hours to 75 minutes; when air temperature is above 90 deg F, reduce mixing and delivery time to 60 minutes.

- C. Project-Site Mixing: Measure, batch, and mix concrete materials and concrete according to ASTM C 94. Mix concrete materials in appropriate drum-type batch machine mixer. For mixer capacity of 1 cubic yard or smaller, continue mixing at least one and one-half minutes, but not more than five minutes after ingredients are in mixer, before any part of batch is released.
 - 1. For mixer capacity larger than 1 cubic yard, increase mixing time by 15 seconds for each additional cubic yard.
 - 2. Provide batch ticket for each batch discharged and used in the Work, indicating Project identification name and number, date, mix type, mix time, quantity, and amount of water added. Record approximate location of final deposit in structure.

PART 3 - EXECUTION

3.01 FORMWORK

- A. Design, construct, erect, shore, brace, and maintain formwork according to ACI 301.

3.02 VAPOR RETARDER

- A. Refer to Section 072600 "Vapor Retarders" for installation requirements.

3.03 SAFETY TREADS:

- A. Install in accordance with manufacturer's requirements, recessed into fresh concrete.

3.04 STEEL REINFORCEMENT

- A. Comply with CRSI's "Manual of Standard Practice" for fabricating, placing, and supporting reinforcement.

3.05 JOINTS

- A. General: Construct joints true to line with faces perpendicular to surface plane of concrete.

- B. Construction Joints: Locate and install so as not to impair strength or appearance of concrete, at locations indicated or as approved by Architect.

- C. Isolation Joints: Install joint-filler strips at junctions with slabs-on-grade and vertical surfaces, such as column pedestals, foundation walls, grade beams, and other locations, as indicated.
- D. Contraction (Control) Joints in Slabs-on-Grade: Form weakened-plane contraction joints, sectioning concrete into areas as indicated. Construct contraction joints for a depth equal to at least one-fourth of the concrete thickness, as follows:

3.06 CONCRETE PLACEMENT

- A. Comply with recommendations in ACI 304R for measuring, mixing, transporting, and placing concrete.
- B. Do not add water to concrete during delivery, at Project site, or during placement.
- C. Consolidate concrete with mechanical vibrating equipment.

3.07 FINISHING FORMED SURFACES

- A. Rough-Formed Finish: As-cast concrete texture imparted by form-facing material with tie holes and defective areas repaired and patched, and fins and other projections exceeding $\frac{1}{4}$ inch in height rubbed down or chipped off.
 - 1. Apply to concrete surfaces not exposed to public view.
- B. Smooth-Formed Finish: As-cast concrete texture imparted by form-facing material, arranged in an orderly and symmetrical manner with a minimum of seams. Repair and patch tie holes and defective areas. Completely remove fins and other projections.
- C. Related Unformed Surfaces: At tops of walls, horizontal offsets, and similar unformed surfaces adjacent to formed surfaces, strike off smooth and finish with a texture matching adjacent formed surfaces. Continue final surface treatment of formed surfaces uniformly across adjacent unformed surfaces, unless otherwise indicated.

3.08 FINISHING UNFORMED SURFACES

- A. General: Comply with ACI 302.1R for screeding, restraightening, and finishing operations for concrete surfaces. Do not wet concrete surfaces.
- B. Screed surfaces with a straightedge and strike off. Begin initial floating using bull floats or darbies to form a uniform and open-textured surface plane before excess moisture or bleedwater appears on the surface.
- C. Scratch Finish: Apply scratch finish to surfaces to receive concrete floor topping or mortar setting beds for ceramic or quarry tile, portland cement terrazzo, and other bonded cementitious floor finish, unless otherwise indicated.

- D. Float Finish: Apply float finish to surfaces indicated, to surfaces to receive trowel finish, and to floor and slab surfaces to be covered with fluid-applied or sheet waterproofing, built-up or membrane roofing, or sand-bed terrazzo.
- E. Trowel Finish: Apply a hard trowel finish to surfaces indicated and to floor and slab surfaces exposed to view or to be covered with resilient flooring, carpet, ceramic or quarry tile set over a cleavage membrane, paint, or another thin film-finish coating system.
- F. Trowel and Fine-Broom Finish: Apply a partial trowel finish, stopping after second troweling, to surfaces indicated and to surfaces where ceramic or quarry tile is to be installed by either thickset or thin-set methods. Immediately after second troweling, and when concrete is still plastic, slightly scarify surface with a fine broom.
- G. Nonslip Broom Finish: Apply a nonslip broom finish to surfaces indicated and to exterior concrete platforms, steps, and ramps. Immediately after float finishing, slightly roughen trafficked surface by brooming with fiber-bristle broom perpendicular to main traffic route.

3.09 TOLERANCES

- A. Comply with ACI 117, "Specifications for Tolerances for Concrete Construction and Materials."

3.010 CONCRETE PROTECTION AND CURING

- A. General: Protect freshly placed concrete from premature drying and excessive cold or hot temperatures. Comply with ACI 306.1 for cold-weather protection, and follow recommendations in ACI 305R for hot-weather protection during curing.
- B. Evaporation Retarder: Apply evaporation retarder to concrete surfaces if hot, dry, or windy conditions cause moisture loss approaching 0.2 lb/sq. ft. x h before and during finishing operations. Apply according to manufacturer's written instructions after placing, screeding, and bull floating or darbying concrete, but before float finishing.
- C. Begin curing after finishing concrete, but not before free water has disappeared from concrete surface.
- D. Curing Methods: Cure formed and unformed concrete for at least seven days by moisture curing, moisture-retaining-cover curing, curing compound, or a combination of these as follows:
 - 1. Moisture Curing: Keep surfaces continuously moist for not less than seven days with the following materials:
 - a. Water.
 - b. Continuous water-fog spray.
 - c. Absorptive cover, water saturated and kept continuously wet. Cover concrete surfaces and edges with 12 inch lap over adjacent absorptive covers.
 - 2. Moisture-Retaining-Cover Curing: Cover concrete surfaces with moisture-retaining cover for curing concrete, placed in widest practicable width, with sides

and ends lapped at least 12 inches, and sealed by waterproof tape or adhesive. Immediately repair any holes or tears during curing period using cover material and waterproof tape.

3. Curing Compound: Apply uniformly in continuous operation by power spray or roller according to manufacturer's written instructions. Recoat areas subjected to heavy rainfall within three hours after initial application. Maintain continuity of coating and repair damage during curing period.

3.10 FIELD QUALITY CONTROL

- A. Testing Agency: Owner will engage a qualified independent testing and inspecting agency to sample materials, perform tests, and submit test reports during concrete placement. Tests will be performed according to ACI 301.
 1. Sampling Fresh Concrete: ASTM C172, except modified for slump to comply with ASTM C 94.
 2. Slump: ASTM C 143, each time a set of compression test specimens made.
 3. Air Content: ASTM C 173, volumetric method for lightweight or normal weight concrete; ASTM C 231 pressure method for normal weight concrete, each time a set of compression test specimens made.
 4. Concrete Temperature: Each time a set of compression test specimens made.
 - a. Compression Test Specimen: ASTM C 31; one set of six standard cylinders for each compressive strength test.
 5. Compressive Strength Test: ASTM C 39; one set for each day's pour plus additional sets for each 50 cubic yards over and above the first 25 cubic yards of each concrete class placed in any one day; two specimens tested at both 7 and 28 days, and two specimens retained in reserve for later testing if required.
 6. Nondestructive Testing: Impact hammer, sonoscope, or other nondestructive device may be permitted for selected instances but shall not be used as the sole basis for acceptance or rejection.

3.11 REPAIRS

- A. Remove and replace concrete that does not comply with requirements in this Section as determined by the Owner or Owners Representative. All such remedial work shall be at the Contractor's expense.

END OF SECTION

THIS PAGE LEFT INTENSIONALLY BLANK

SECTION 035413 - GYPSUM CEMENT UNDERLAYMENT

PART 1 - GENERAL

1.1 SUMMARY

A. Section Includes:

1. Self-leveling, gypsum cement underlayment on acoustic mat for application below interior floor coverings.

1.2 PREINSTALLATION MEETING

- A. Preinstallation Conference: Conduct conference at Project site.

1.3 ACTION SUBMITTALS

A. Product Data: For the following:

1. Gypsum cement underlayment and acoustic mat.
2. Reinforcement.
3. Floor Primer.
4. Overspray primer sealer.
5. Acoustical Data: Submit sound tests according to IBC code criteria ASTM E492 (IIC) and ASTM E90 (STC) or ASTM E1007 (F-IIC) and E336 (F-IIC).

1.4 QUALITY ASSURANCE

- A. Installer Qualifications: Installer who is approved by manufacturer for application of underlayment products required for this Project.
- B. Underlayment mix shall be tested for a slump using a 2" (i.d.) x 4" (50 mm x 101 mm) cylinder resulting in a patty size of 8 1/2" (216 mm) plus or minus 1 inch (25 mm) diameter.
- C. GREENGUARD and GREENGUARD Gold Certified.

1.5 DELIVERY, STORAGE, AND HANDLING

- A. All materials shall be delivered in their original unopened packages and protected from damage and exposure from the elements. Damaged or deteriorated materials shall be removed from the premises.

1.6 FIELD CONDITIONS

- A. Environmental Limitations: Comply with manufacturer's written instructions for substrate temperature, ventilation, ambient temperature and humidity, and other conditions affecting underlayment performance.
1. Place gypsum cement underlayment only when ambient temperature and temperature of substrates are between 50 and 80 deg F (10 and 27 deg C).

PART 2 - PRODUCTS

2.1 GYPSUM CEMENT UNDERLAYMENTS

- A. Gypsum Cement Underlayment: Self-leveling, gypsum cement product for use over wood floors with a deflection limitation of L/360 and applied in a uniform thickness of 1 inch (25.4 mm).
1. Manufacturer: Subject to compliance with requirements, provide products by the following:
 - a. Maxxon Corporation, Hamel, MN., Tele: (800) 356-7887, www.maxxon.com, Gyp-crete 2000/3.2K.
 2. Dry Density: 115 pcf (1,842 kg/m³).
 3. Compressive Strength: Typical range of 2000 psi (13.8 MPa) to 3200 psi (22.1 MPa) at 28 days when tested according to ASTM C472.
- B. Acoustic Mat: Provide for sound control as follows:
1. Acousti-Mat 3/8 Premium Sound Mat as manufactured by Maxxon Corporation, Hamel, MN.
 2. Acousti-Mat Perimeter Isolation Strips as manufactured by Maxxon Corporation, Hamel, MN.
 3. Acousti-Mat Tape as manufactured by Maxxon Corporation, Hamel, MN.
- C. Aggregate: Well-graded, sand as specified by underlayment manufacturer.
- D. Water: Potable and at a temperature of not more than 70 deg F (21 deg C).
- E. Reinforcement: For underlayment applied to wood substrates, provide galvanized metal lath or other corrosion-resistant reinforcement recommended in writing by underlayment manufacturer.
- F. Floor Primer: Product of underlayment manufacturer recommended in writing for wood substrate, conditions, and application indicated.
- G. Overspray Primer Sealer: Product of underlayment manufacturer and designed to reduce porosity as recommended by manufacturer for type of floor covering to be applied to underlayment.

PART 3 - EXECUTION

3.1 PREPARATION

- A. Installation is not to begin until the building is enclosed, including roof, windows, doors, and any other apertures.
- B. Prepare and clean substrate according to manufacturer's written instructions.
 - 1. Treat nonmoving substrate cracks according to manufacturer's written instructions to prevent cracks from telegraphing (reflecting) through underlayment.
 - 2. Fill substrate voids to prevent underlayment from leaking.
- C. Wood Substrates: Mechanically fasten loose boards and panels to eliminate substrate movement and squeaks. Sand to remove coatings that might impair underlayment bond and remove sanding dust. Clean subfloor to remove mud, oil, grease, and other contaminating factors.
 - 1. Install underlayment reinforcement recommended in writing by manufacturer.

3.2 INSTALLATION

- A. Mix and install underlayment components according to manufacturer's written instructions. Mix proportions and methods shall be in strict accordance with manufacturer recommendations
 - 1. Close areas to traffic during underlayment installation and for time period after installation recommended in writing by manufacturer.
 - 2. Coordinate installation of components to provide optimum adhesion to substrate and between coats.
 - 3. At substrate expansion, isolation, and other moving joints, allow joint of same width to continue through underlayment.
- B. Apply primer over prepared substrate at manufacturer's recommended spreading rate.
- C. Install Acousti-Mat following manufacturer's recommendations and specifications including installation of Perimeter Isolation Strips at the perimeter of all areas receiving Acousti-Mat (including doorframes) and around any protrusions through the installation. Adhere the foam perimeter isolation strip to the wall with Acousti-Mat Tape.
- D. Install underlayment to produce uniform, level surface.
 - 1. Pour floor topping to recommended thickness. Immediately spread and screed product to a smooth surface. Expansion joints in all types of work shall be brought through the underlayment.
- E. Cure underlayment according to manufacturer's written instructions. Prevent contamination during installation and curing processes and protect against infestation of moisture.

- F. Protection from Heavy Loads: During construction, place temporary wood planking over underlayment wherever it will be subject to heavy wheeled or concentrated loads
- G. Do not install floor coverings over underlayment until after time period recommended in writing by underlayment manufacturer.
- H. Remove and replace underlayment areas that evidence lack of bond with substrate, including areas that emit a "hollow" sound when tapped.

3.3 PREPARATION FOR INSTALLATION OF GLUE DOWN FLOORING

- A. Sealing:
 - 1. Seal all areas that receive glue down floor goods with Overspray Primer Sealer according to the manufacturer specifications. Any floor areas where the surface has been damaged shall be cleaned and sealed regardless of floor covering to be used. Where floor goods manufacturers require special adhesive or installation systems, their requirements supersede these recommendations.
- B. Moisture Testing:
 - 1. Follow the respective floor goods manufacturers' recommendations for relative humidity requirements. When manufacturer does not have a relative humidity requirement, refer to manufacturer's "*Procedures for Attaching Finished Floor Goods to Maxxon Underlayments*" brochure

3.4 INSTALLATION TOLERANCES

- A. Finish and measure surface, so gap at any point between gypsum cement underlayment surface and an unlevelled, freestanding, 10-foot- (3.05-m-) long straightedge resting on two high spots and placed anywhere on the surface does not exceed 1/8 inch (3 mm).

END OF SECTION 035413

SECTION 042200 - CONCRETE UNIT MASONRY

PART 1 - GENERAL

1.1 SUMMARY

- A. Section Includes:
1. Concrete masonry units.
 2. Steel reinforcing bars.

1.2 DEFINITIONS

- A. CMU(s): Concrete masonry unit(s).
- B. Reinforced Masonry: Masonry containing reinforcing steel in grouted cells.

1.3 ACTION SUBMITTALS

- A. Product Data: For each type of product.
- B. Shop Drawings: For reinforcing steel. Detail bending, lap lengths, and placement of unit masonry reinforcing bars. Comply with ACI 315.

1.4 INFORMATIONAL SUBMITTALS

- A. Material Certificates: For each type and size of product. For masonry units, include material test reports substantiating compliance with requirements.
- B. Mix Designs: For each type of mortar and grout. Include description of type and proportions of ingredients.
1. Include test reports for mortar mixes required to comply with property specification. Test according to ASTM C 109/C 109M for compressive strength, ASTM C 1506 for water retention, and ASTM C 91/C 91M for air content.
 2. Include test reports, according to ASTM C 1019, for grout mixes required to comply with compressive strength requirement.

1.5 FIELD CONDITIONS

- A. Cold-Weather Requirements: Do not use frozen materials or materials mixed or coated with ice or frost. Do not build on frozen substrates. Remove and replace unit masonry damaged by frost or by freezing conditions. Comply with cold-weather construction requirements contained in TMS 602/ACI 530.1/ASCE 6.

- B. Hot-Weather Requirements: Comply with hot-weather construction requirements contained in TMS 602/ACI 530.1/ASCE 6.

PART 2 - PRODUCTS

2.1 UNIT MASONRY, GENERAL

- A. Masonry Standard: Comply with TMS 602/ACI 530.1/ASCE 6, except as modified by requirements in the Contract Documents.
- B. Defective Units: Referenced masonry unit standards may allow a certain percentage of units to contain chips, cracks, or other defects exceeding limits stated. Do not use units where such defects are exposed in the completed Work.

2.2 CONCRETE MASONRY UNITS

- A. Shapes: Provide shapes indicated and as follows, with exposed surfaces matching exposed faces of adjacent units unless otherwise indicated.
 - 1. Provide special shapes for lintels, corners, jambs, sashes, movement joints, headers, bonding, and other special conditions.
- B. Integral Water Repellent: Provide units made with integral water repellent for exposed units.
- C. CMUs: ASTM C 90.
 - 1. Unit Compressive Strength: Provide units with minimum average net-area compressive strength of 2150 psi (14.8 MPa).
 - 2. Density Classification: Normal weight unless otherwise indicated on Structural Drawings.
- D. Concrete Building Brick: ASTM C 55.
 - 1. Unit Compressive Strength: Provide units with minimum average net-area compressive strength of 2800 psi (19.3 MPa).
 - 2. Density Classification: Normal weight.
 - a. .

2.3 CONCRETE AND MASONRY LINTELS

- A. Concrete Lintels: ASTM C 1623, matching CMUs in color, texture, and density classification; and with reinforcing bars indicated. Provide lintels with net-area compressive strength not less than that of CMUs.
- B. Masonry Lintels: Prefabricated or built-in-place masonry lintels made from bond beam CMUs with reinforcing bars placed as indicated and filled with coarse grout.

2.4 MORTAR AND GROUT MATERIALS

- A. Portland Cement: ASTM C 150/C 150M, Type I or II, except Type III may be used for cold-weather construction. Provide natural color or white cement as required to produce mortar color indicated.
- B. Hydrated Lime: ASTM C 207, Type S.
- C. Portland Cement-Lime Mix: Packaged blend of portland cement and hydrated lime containing no other ingredients.
- D. Masonry Cement: ASTM C 91/C 91M.
- E. Aggregate for Mortar: ASTM C 144.
 - 1. White-Mortar Aggregates: Natural white sand or crushed white stone.
- F. Aggregate for Grout: ASTM C 404.
- G. Cold-Weather Admixture: Nonchloride, noncorrosive, accelerating admixture complying with ASTM C 494/C 494M, Type C, and recommended by manufacturer for use in masonry mortar of composition indicated.
- H. Water-Repellent Admixture: Liquid water-repellent mortar admixture intended for use with CMUs containing integral water repellent from same manufacturer.
- I. Water: Potable.

2.5 REINFORCEMENT

- A. Uncoated-Steel Reinforcing Bars: ASTM A 615/A 615M or ASTM A 996/A 996M, Grade 60 (Grade 420).
- B. Reinforcing Bar Positioners: Wire units designed to fit into mortar bed joints spanning masonry unit cells and to hold reinforcing bars in center of cells. Units are formed from 0.148-inch (3.77-mm) steel wire, hot-dip galvanized after fabrication. Provide units designed for number of bars indicated.
- C. Masonry-Joint Reinforcement, General: ASTM A 951/A 951M.
 - 1. Interior and Exterior Walls: Hot-dip galvanized, carbon steel.
 - 2. Wire Size for Side Rods: 0.148-inch (3.77-mm) diameter.
 - 3. Wire Size for Cross Rods: 0.148-inch (3.77-mm) diameter.
 - 4. Spacing of Cross Rods: Not more than 16 inches (407 mm) o.c.
 - 5. Provide in lengths of not less than 10 feet (3 m), with prefabricated corner and tee units.
- D. Masonry-Joint Reinforcement for Single-Wythe Masonry: Ladder or truss type with single pair of side rods.

2.6 TIES AND ANCHORS

- A. Materials: Provide ties and anchors specified in this article that are made from materials that comply with the following unless otherwise indicated:
1. Hot-Dip Galvanized, Carbon-Steel Wire: ASTM A 82/A 82M, with ASTM A 153/A 153M, Class B-2 coating.
 2. Steel Sheet, Galvanized after Fabrication: ASTM A 1008/A 1008M, Commercial Steel, with ASTM A 153/A 153M, Class B coating.
 3. Steel Plates, Shapes, and Bars: ASTM A 36/A 36M.
- B. Rigid Anchors: Fabricate from steel bars 1-1/2 inches (38 mm) wide by 1/4 inch (6.35 mm) thick by 24 inches (610 mm) long, with ends turned up 2 inches (51 mm) or with cross pin.
1. Corrosion Protection: Hot-dip galvanized to comply with ASTM A 153/A 153M.

2.7 EMBEDDED FLASHING MATERIALS

- A. Metal Flashing: Provide metal flashing complying with Section 076200 "Sheet Metal Flashing and Trim" and as follows:
1. Fabricate metal drip edges from stainless steel. Extend at least 3 inches (76 mm) into wall and 1/2 inch (13 mm) out from wall, with outer edge bent down 30 degrees and hemmed.
 2. Fabricate metal sealant stops from stainless steel. Extend at least 3 inches (76 mm) into wall and out to exterior face of wall. At exterior face of wall, bend metal back on itself for 3/4 inch (19 mm) and down into joint 1/4 inch (6 mm) to form a stop for retaining sealant backer rod.
- B. Flexible Flashing: Use the following unless otherwise indicated:
1. Self-Adhering Flashing: Composite flashing product consisting of a pliable, 8 mils butyl adhesive with siliconized release liner, bonded to 304 stainless steel, 2 mil thick to produce an overall thickness of not less than 10 mils thick.
 - a. Accessories: Provide preformed corners, end dams, other special shapes, and seaming materials produced by flashing manufacturer.
 - b. Acceptable Manufacturer: York Flashings; York 304, www.yorkmfg.com.
- C. Termination Bars for Flexible Flashing: Aluminum bars 0.075 inch by 1 inch (1.90 mm by 25 mm) in locations where required by manufacturer and where flashings terminate on the vertical face of a substrate.
- D. Solder and Sealants for Sheet Metal Flashings: As specified in Section 076200 "Sheet Metal Flashing and Trim."
- E. Adhesives, Primers, and Seam Tapes for Flashings: Flashing manufacturer's standard products or products recommended by flashing manufacturer for bonding flashing sheets to each other and to substrates.

2.8 MISCELLANEOUS MASONRY ACCESSORIES

- A. Compressible Filler: Premolded filler strips complying with ASTM D 1056, Grade 2A1; compressible up to 35 percent; of width and thickness indicated; formulated from neoprene or urethane.
- B. Preformed Control-Joint Gaskets: Made from styrene-butadiene-rubber compound, complying with ASTM D 2000, Designation M2AA-805 and designed to fit standard sash block and to maintain lateral stability in masonry wall; size and configuration as indicated.
- C. Bond-Breaker Strips: Asphalt-saturated felt complying with ASTM D 226/D 226M, Type I (No. 15 asphalt felt).

2.9 MORTAR AND GROUT MIXES

- A. General: Do not use admixtures, including pigments, air-entraining agents, accelerators, retarders, water-repellent agents, antifreeze compounds, or other admixtures unless otherwise indicated.
 - 1. Do not use calcium chloride in mortar or grout.
 - 2. Use portland cement-lime or masonry cement mortar unless otherwise indicated and as follows.
 - 3. For exterior masonry, use portland cement-lime mortar.
 - 4. For reinforced masonry, use portland cement-lime mortar.
 - 5. Add cold-weather admixture (if used) at same rate for all mortar that will be exposed to view, regardless of weather conditions, to ensure that mortar color is consistent.
- B. Preblended, Dry Mortar Mix: Furnish dry mortar ingredients in form of a preblended mix. Measure quantities by weight to ensure accurate proportions, and thoroughly blend ingredients before delivering to Project site.
- C. Mortar for Unit Masonry: Comply with ASTM C 270, Proportion Specification. Provide the following types of mortar for applications stated unless another type is indicated.
 - 1. For masonry below grade or in contact with earth, use Type M.
 - 2. For reinforced masonry, use Type S.
 - 3. For exterior, above-grade, load-bearing and nonload-bearing walls and parapet walls; for interior load-bearing walls; for interior nonload-bearing partitions; and for other applications where another type is not indicated, use Type N.
- D. Grout for Unit Masonry: Comply with ASTM C 476.
 - 1. Use grout of type indicated or, if not otherwise indicated, of type (fine or coarse) that will comply with TMS 602/ACI 530.1/ASCE 6 for dimensions of grout spaces and pour height.
 - 2. Proportion grout in accordance with ASTM C 476, Table 1 or paragraph 4.2.2 for specified 28-day compressive strength indicated, but not less than 2000 psi (14 MPa).
 - 3. Provide grout with a slump of 8 to 11 inches (200 to 280 mm) as measured according to ASTM C 143/C 143M.

PART 3 - EXECUTION

3.1 INSTALLATION, GENERAL

- A. Use full-size units without cutting if possible. If cutting is required to provide a continuous pattern or to fit adjoining construction, cut units with motor-driven saws; provide clean, sharp, unchipped edges. Allow units to dry before laying unless wetting of units is specified. Install cut units with cut surfaces and, where possible, cut edges concealed.

3.2 TOLERANCES

A. Dimensions and Locations of Elements:

1. For dimensions in cross section or elevation, do not vary by more than plus 1/2 inch (12 mm) or minus 1/4 inch (6 mm).
2. For location of elements in plan, do not vary from that indicated by more than plus or minus 1/2 inch (12 mm).
3. For location of elements in elevation, do not vary from that indicated by more than plus or minus 1/4 inch (6 mm) in a story height or 1/2 inch (12 mm) total.

B. Lines and Levels:

1. For conspicuous horizontal lines, such as lintels, sills, parapets, and reveals, do not vary from level by more than 1/8 inch in 10 feet (3 mm in 3 m), 1/4 inch in 20 feet (6 mm in 6 m), or 1/2-inch (12-mm) maximum.
2. For vertical lines and surfaces, do not vary from plumb by more than 1/4 inch in 10 feet (6 mm in 3 m), 3/8 inch in 20 feet (9 mm in 6 m), or 1/2-inch (12-mm) maximum.
3. For conspicuous vertical lines, such as external corners, door jambs, reveals, and expansion and control joints, do not vary from plumb by more than 1/8 inch in 10 feet (3 mm in 3 m), 1/4 inch in 20 feet (6 mm in 6 m), or 1/2-inch (12-mm) maximum.
4. For lines and surfaces, do not vary from straight by more than 1/4 inch in 10 feet (6 mm in 3 m), 3/8 inch in 20 feet (9 mm in 6 m), or 1/2-inch (12-mm) maximum.

C. Joints:

1. For bed joints, do not vary from thickness indicated by more than plus or minus 1/8 inch (3 mm), with a maximum thickness limited to 1/2 inch (12 mm).
2. For head and collar joints, do not vary from thickness indicated by more than plus 3/8 inch (9 mm) or minus 1/4 inch (6 mm).
3. For exposed head joints, do not vary from thickness indicated by more than plus or minus 1/8 inch (3 mm).

3.3 LAYING MASONRY WALLS

- A. Lay out walls in advance for accurate spacing of surface bond patterns with uniform joint thicknesses and for accurate location of openings, movement-type joints, returns, and offsets.

Avoid using less-than-half-size units, particularly at corners, jambs, and, where possible, at other locations.

- B. Bond Pattern for Exposed Masonry: Unless otherwise indicated, lay exposed masonry in running bond; do not use units with less-than-nominal 4-inch (100-mm) horizontal face dimensions at corners or jambs.
- C. Built-in Work: As construction progresses, build in items specified in this and other Sections. Fill in solidly with masonry around built-in items.
- D. Fill space between steel frames and masonry solidly with mortar unless otherwise indicated.
- E. Where built-in items are to be embedded in cores of hollow masonry units, place a layer of metal lath, wire mesh, or plastic mesh in the joint below, and rod mortar or grout into core.
- F. Fill cores in hollow CMUs with grout 24 inches (600 mm) under bearing plates, beams, lintels, posts, and similar items unless otherwise indicated.

3.4 MORTAR BEDDING AND JOINTING

- A. Lay hollow CMUs as follows:
 - 1. Bed face shells in mortar and make head joints of depth equal to bed joints.
 - 2. Bed webs in mortar in all courses of piers, columns, and pilasters.
 - 3. Bed webs in mortar in grouted masonry, including starting course on footings.
 - 4. Fully bed entire units, including areas under cells, at starting course on footings where cells are not grouted.
- B. Lay solid CMUs with completely filled bed and head joints; butter ends with sufficient mortar to fill head joints and shove into place. Do not deeply furrow bed joints or slush head joints.
- C. Tool exposed joints slightly concave when thumbprint hard, using a jointer larger than joint thickness unless otherwise indicated.
- D. Cut joints flush for masonry walls to receive plaster or other direct-applied finishes (other than paint) unless otherwise indicated.

3.5 MASONRY-JOINT REINFORCEMENT

- A. General: Install entire length of longitudinal side rods in mortar with a minimum cover of 5/8 inch (16 mm) on exterior side of walls, 1/2 inch (13 mm) elsewhere. Lap reinforcement a minimum of 6 inches (150 mm).
 - 1. Space reinforcement not more than 16 inches (406 mm) o.c.
 - 2. Space reinforcement not more than 8 inches (203 mm) o.c. in foundation walls and parapet walls.

3. Provide reinforcement not more than 8 inches (203 mm) above and below wall openings and extending 12 inches (305 mm) beyond openings in addition to continuous reinforcement.
- B. Interrupt joint reinforcement at control and expansion joints unless otherwise indicated.
- C. Provide continuity at wall intersections by using prefabricated T-shaped units.
- D. Provide continuity at corners by using prefabricated L-shaped units.

3.6 FLASHING

- A. General: Install embedded flashing at ledges and other obstructions to downward flow of water in wall where indicated.
- B. Install flashing as follows unless otherwise indicated:
 1. Prepare masonry surfaces so they are smooth and free from projections that could puncture flashing. Where flashing is within mortar joint, place through-wall flashing on sloping bed of mortar and cover with mortar. Before covering with mortar, seal penetrations in flashing with adhesive, sealant, or tape as recommended by flashing manufacturer.
 2. At lintels, extend flashing a minimum of 6 inches (150 mm) into masonry at each end. At heads and sills, extend flashing 6 inches (150 mm) at ends and turn up not less than 2 inches (50 mm) to form end dams.
 3. Install metal drip edges beneath flexible flashing at exterior face of wall. Stop flexible flashing 1/2 inch (13 mm) back from outside face of wall, and adhere flexible flashing to top of metal drip edge.
 4. Install metal flashing termination beneath flexible flashing at exterior face of wall. Stop flexible flashing 1/2 inch (13 mm) back from outside face of wall, and adhere flexible flashing to top of metal flashing termination.

3.7 REINFORCED UNIT MASONRY INSTALLATION

- A. Temporary Formwork and Shores: Construct formwork and shores as needed to support reinforced masonry elements during construction.
 1. Construct formwork to provide shape, line, and dimensions of completed masonry as indicated. Make forms sufficiently tight to prevent leakage of mortar and grout. Brace, tie, and support forms to maintain position and shape during construction and curing of reinforced masonry.
 2. Do not remove forms and shores until reinforced masonry members have hardened sufficiently to carry their own weight and that of other loads that may be placed on them during construction.
- B. Placing Reinforcement: Comply with requirements in TMS 602/ACI 530.1/ASCE 6.

- C. Grouting: Do not place grout until entire height of masonry to be grouted has attained enough strength to resist grout pressure.
 - 1. Comply with requirements in TMS 602/ACI 530.1/ASCE 6 for cleanouts and for grout placement, including minimum grout space and maximum pour height.
 - 2. Limit height of vertical grout pours to not more than 60 inches (1520 mm).

3.8 FIELD QUALITY CONTROL

- A. Testing and Inspecting: Owner will engage special inspectors to perform tests and inspections and prepare reports. Allow inspectors access to scaffolding and work areas as needed to perform tests and inspections. Retesting of materials that fail to comply with specified requirements shall be done at Contractor's expense.
- B. Inspections: Special inspections according to Level C in TMS 402/ACI 530/ASCE 5.
 - 1. Begin masonry construction only after inspectors have verified proportions of site-prepared mortar.
 - 2. Place grout only after inspectors have verified compliance of grout spaces and of grades, sizes, and locations of reinforcement.
 - 3. Place grout only after inspectors have verified proportions of site-prepared grout.
- C. Testing Prior to Construction: One set of tests.
- D. Testing Frequency: One set of tests for each 2500 sq. ft. (232 sq. m) of wall area or portion thereof.
- E. Concrete Masonry Unit Test: For each type of unit provided, according to ASTM C 140 for compressive strength.
- F. Mortar Aggregate Ratio Test (Proportion Specification): For each mix provided, according to ASTM C 780.
- G. Mortar Test (Property Specification): For each mix provided, according to ASTM C 780. Test mortar for mortar air content and compressive strength.
- H. Grout Test (Compressive Strength): For each mix provided, according to ASTM C 1019.
- I. Prism Test: For each type of construction provided, according to ASTM C 1314 at seven days and at 28 days.

3.9 REPAIRING, POINTING, AND CLEANING

- A. In-Progress Cleaning: Clean unit masonry as work progresses by dry brushing to remove mortar fins and smears before tooling joints.
- B. Final Cleaning: After mortar is thoroughly set and cured, clean exposed masonry as follows:

1. Test cleaning methods on sample wall panel; leave one-half of panel uncleaned for comparison purposes.
2. Protect adjacent surfaces from contact with cleaner.
3. Clean concrete masonry by applicable cleaning methods indicated in NCMA TEK 8-4A.

3.10 MASONRY WASTE DISPOSAL

- A. Waste Disposal as Fill Material: Dispose of clean masonry waste, including excess or soil-contaminated sand, waste mortar, and broken masonry units, by crushing and mixing with fill material as fill is placed.
 1. Do not dispose of masonry waste as fill within 18 inches (450 mm) of finished grade.
- B. Masonry Waste Recycling: Return broken CMUs not used as fill to manufacturer for recycling.
- C. Excess Masonry Waste: Remove excess clean masonry waste that cannot be used as fill, as described above or recycled, and other masonry waste, and legally dispose of off Owner's property.

END OF SECTION 042200

SECTION 044313.16 - ADHERED STONE MASONRY VENEER

PART 1 - GENERAL

1.1 SUMMARY

A. Section Includes:

1. Thin Veneer Stone masonry adhered to wood sheathing at concrete foundation.
2. Thin Veneer Stone masonry adhered to wood Structural Insulated Panels.
3. Thin Veneer Stone masonry adhered to wood framing and sheathing.

1.2 PREINSTALLATION MEETING

- A. Preinstallation Conference: Conduct conference at Project site.

1.3 ACTION SUBMITTALS

- A. Product Data and Profile Drawings: For variety of stone, stone accessory, mortar, and manufactured product.
- B. Submit manufacturers' installation instructions.
- C. Submit proof of warranty.
- D. Samples:
1. For thin veneer stone type indicated.
 2. For color of mortar required.

1.4 QUALITY ASSURANCE

- A. Adhered Masonry Veneer Manufacturer: Company specializing in adhered masonry veneer, trim units with five (5) years minimum experience. Obtain adhered masonry veneer from a single source with resources to provide products of consistent quality in appearance and physical properties.
- B. Submit positive laboratory testing to confirm applicability of membrane air barrier, adhesives, mortars, pointing mortars, and other installation materials for specified job conditions.
- C. Installer qualifications: company specializing in installation of adhered masonry veneer with five (5) years documented experience with installations of similar scope, materials and design.

- D. Provide mock-up of adhered masonry veneer and cast stone trim unit along with respective installation air barrier, waterproofing membranes, adhesives, mortars pointing mortars and other installation materials.
1. Approval of mockups does not constitute approval of deviations from the Contract Documents contained in mockups unless Architect specifically approves such deviations in writing.
 2. Subject to compliance with requirements, approved mockups may become part of the completed Work if undisturbed at time of Substantial Completion.

1.5 DELIVERY, STORAGE, AND HANDLING

- A. Deliver natural thin stone masonry units in protective film. Prevent damage to units.
- B. Store units in a manner designed to prevent damage and staining of units. Stack units on timbers or platforms at least 3 inches above grade and place polyethylene or other plastic film between wood and other finished surfaces of units when stored for extended periods of time. Store adhered masonry veneer and installation system materials including mortars in a dry location; handle in a manner to prevent chipping, breakage, and contamination. Cover stored units with protective enclosure if exposed to weather.
- C. Do not use salt or calcium-chloride to remove ice from masonry surfaces.

1.6 FIELD CONDITIONS

- A. Protection of Stone Masonry: During construction, cover tops of walls, projections, and sills with waterproof sheeting at end of each day's work. Protect work for extended period of time and from damage by other trades.
- B. Maintain ambient temperatures not less than 37°F (3°C) or more than 100°F (38°C) during installation and for a minimum of seven (7) days after completion. Setting of portland cement is retarded by low temperatures/.
- C. Cold-Weather Requirements: Do not use frozen materials or materials mixed or coated with ice or frost. Do not build on frozen substrates. Comply with cold-weather construction requirements contained in TMS 602/ACI 530.1/ASCE 6.
1. Cold-Weather Cleaning: Use liquid cleaning methods only when air temperature is 40 deg F (4 deg C) and above and will remain so until masonry has dried.
- D. Hot-Weather Requirements: Comply with hot-weather construction requirements contained in TMS 602/ACI 530.1/ASCE 6.

PART 2 - PRODUCTS

2.1 MANUFACTURERS

- A. Subject to compliance with performance requirements, provide products by the following manufacturers:
1. Natural Thin Stone Units: Natural Stone Veneers International, Inc., Fond du Lac, WI. 920-923-2800, www.nsvi.com.
 2. Adhered Masonry Veneer Installation Materials and Accessories: Laticrete International.

2.2 LIMESTONE

- A. Material Standard: Comply with ASTM C568/C568M.
1. Maximum absorption rate tested in accordance with ASTM C97: 3 percent.
 2. Minimum density tested in accordance with ASTM C97: 2,560 kg per cubic meter.
 3. Minimum compressive strength tested in accordance with ASTM C170: 55 Mpa.
 4. Minimum flexural strength tested in accordance with ASTM C 880: 8.27 Mpa.
- B. Varieties and Sources: Subject to compliance with requirements, provide the following:
1. Graphite Country, Traditional Type
 - a. Nominal size range:
 - 1) Length: 6 to 20 inches (152 to 508 mm).
 - 2) Height: 2 to 6 inches (50.8 to 152 mm).
 - 3) Width: 3/4 to 1 1/4 inches (19 to 31 mm).
 - b. Weight: 14.9 lbs. per sq. ft.
 - c. Color range: Charcoal, Gray-Gray, Tan.
 - d. Ends: square.

2.3 CEMENT BOARD

- A. Backer Board: Cementitious, water durable, board; surfaced with fiberglass reinforcing mesh on front and back; long edges wrapped; and complying with ANSI A118.9 and ASTM C 1325.
1. Thickness: 1/2 in.
 2. Width: 2 ft. 8 in., 3 ft., or 4 ft.
 3. Length: 4 ft., 5 ft., 6 ft., or 8 ft.
 4. Edges: Tapered.
 5. Compressive Strength: Not less than 2250 lbs. per sq. in. when tested in accordance with ASTM D 2394.
 6. Water Absorption: Not greater than 8% when tested for 24 hours in accordance with ASTM C 473.

B. Fasteners:

1. Screws: Hi-Lo thread screws (No. 8) wafer head, corrosion-resistant, [1-1/4 in], [1-5/8], [2-1/4 in] in length, and complying with ASTM C 1002

C. Joint Treatment:

1. Tape: Alkali-resistant fiberglass mesh tape intended for use with cement board.

D. Bonding Materials:

1. Mortar: Latex-portland cement mortar in accordance with ANSI A118.4.

2.4 MORTAR AND ACCESSORY MATERIALS

A. Air and Water Barrier Membrane: LATICRETE® Air & Water Barrier to be thin, cold applied, single component liquid and load bearing. Waterproofing Membrane to be non-toxic, non-flammable, and non-hazardous during storage, mixing, application and when cured:

- | | |
|---|---------------------------|
| 1. Air Barrier Test (AC 212): | Pass |
| 2. Air Permeance (ASTM E2178): | Pass |
| 3. Elongation @ break (ASTM D751): | 20-30% |
| 4. 7 day Tensile Strength (ANSI A118.10): | >265 psi (1.8 MPa) |
| 5. 7 day Shear Bond Strength (ANSI A118.10) | >200 psi (1.4 MPa) |
| 6. 28 Day Shear Bond Strength (ANSI A118.4): | >214 psi (1.48 – 2.4 MPa) |
| 7. Service Rating (TCA/ASTM C627): | Extra Heavy |
| 8. Total VOC Content: | < 0.05 mg/m ³ |
| 9. Fire Propagation Characteristics: Passes NFPA 285 testing as part of an approved assembly. | |
| 10. Flame Spread: Not more than 25; ASTM E84. | |
| 11. Smoke Developed: Not more than 85; ASTM E84. | |

B. Epoxy Waterproofing Flashing Mortar: LATAPOXY® Waterproof Flashing Mortar to be 3 component epoxy, trowel applied specifically designed to be used under adhered masonry veneer:

- | | |
|--|---------------------------|
| 1. Breaking Strength (ANSI A118.10): | 450-530 psi (3.1-3.6 MPa) |
| 2. Waterproofness (ANSI A118.10): | No Water penetration |
| 3. 7 day Shear Bond Strength (ANSI A118.10): | 110-150 psi (0.8-1 MPa) |
| 4. 28 Day Shear Bond Strength (ANSI A118.10): | 90-120 psi (0.6–0.83 MPa) |
| 5. 12 Week Shear Bond Strength (ANSI A118.10): | 110-130 psi (0.8-0.9 MPa) |
| 6. Total VOC Content: | <3.4 g/L |

C. Latex-Portland Cement Mortar for leveling beds and scratch/plaster coats: LATICRETE MVIS Premium Mortar Bed to meet the following physical requirements:

- | | |
|---|----------------------|
| 1. Compressive Strength (ANSI A118.4 Modified): | >4000 psi (27.6 MPa) |
| 2. Water Absorption (ANSI A118.6): | ≤ 5% |
| 3. Service Rating (TCA/ASTM C627): | Extra Heavy |

4. Smoke & Flame Contribution (ASTM E84 Modified): 0
 5. Total VOC Content: < 0.05 mg/m³
- D. Latex Portland Cement Mortar: MVIS Hi Bond Veneer Mortar to be weather, frost, shock resistant, non-flammable and meet the following physical requirements:
1. Compressive strength (ANSI A118.4): >2500 psi (17.2 MPa)
 2. Bond strength (ANSI A118.4): >450 psi (3.1 MPa)
 3. Smoke & Flame Contribution (ASTM E84 Modified): 0
 4. Total VOC Content: < 0.05 mg/m³
- E. Latex Portland Cement Pointing Mortar / Grout: MVIS Pointing Mortar ** to be weather, frost and shock resistant, as well as meet the following physical requirements:
1. Compressive Strength (ASTM C91) 3500 psi (24.1 MPa)
 2. Smoke & Flame Contribution (ASTM E84 Modified): 0
 3. Total VOC Content: < 0.00 mg/m³
- F. Expansion and Control Joint Sealant: MVIS Silicone Sealant to be a one component, neutral cure, exterior grade silicone sealant and meet the following requirements:
1. Tensile Strength (ASTM C794): 280 psi (1.9 MPa)
 2. Hardness (ASTM D751; Shore A): 25 (colored sealant) /15 (clear sealant)
 3. Weather Resistance (QUV Weather-ometer): 10000 hours (no change)
- G. Spot Bonding Epoxy Adhesive: LATAPOXY 310 Stone Adhesive (Standard or Rapid Grade) for installing adhered masonry veneer, brick and stone over vertical and overhead surfaces shall be high strength, high temperature resistant, non-sag and shall meet the following physical requirements:
1. Thermal Shock Resistance (ANSI A118.3): >1000 psi (6.9 MPa)
 2. Water Absorption (ANSI A118.3): 0.1 %
 3. Compressive Strength (ANSI A118.3): >8300 psi (57.2 MPa)
 4. Shear Bond Strength (ANSI A118.3 Modified): >730 psi (5 MPa)
- H. Colored Portland Cement-Lime Mix: Packaged blend of portland cement, hydrated lime, and mortar pigments. Mix shall produce color indicated or, if not indicated, as selected from manufacturer's standard colors. Pigments shall not exceed 10 percent of portland cement by weight.
- I. Aggregate: ASTM C144 and as follows:
1. For pointing mortar, use aggregate graded with 100 percent passing No. 16 (1.18-mm) sieve.
 2. White Aggregates: Natural white sand or ground white stone.
 3. Colored Aggregates: Natural-colored sand or ground marble, granite, or other sound stone; of color necessary to produce required mortar color.
- J. Water: Potable.

2.5 EMBEDDED FLASHING MATERIALS

- A. Metal Flashing: Provide metal flashing, where flashing is exposed or partly exposed and where indicated, complying with SMACNA's "Architectural Sheet Metal Manual" and as follows:
 - 1. Stainless Steel: ASTM A240/A240M, Type 304, 0.016 inch (0.4 mm) thick.
- B. Flexible Flashing: For flashing unexposed to the exterior, use the following:
 - 1. Self-Adhering Flashing: Composite flashing product consisting of a pliable, 8 mils butyl adhesive with siliconized release liner, bonded to 304 stainless steel, 2 mil thick to produce an overall thickness of not less than 10 mils thick.
 - 2. Accessories: Provide preformed corners, end dams, other special shapes, and seaming materials produced by flashing manufacturer.
 - 3. Acceptable Manufacturer: York Flashings; York 304, www.yorkmfg.com.

2.6 MASONRY CLEANERS

- A. Proprietary Acidic Cleaner: Manufacturer's standard-strength cleaner designed for removing mortar and grout stains, efflorescence, and other new construction stains from stone masonry surfaces without discoloring or damaging masonry surfaces; expressly approved for intended use by cleaner manufacturer and stone producer.

2.7 FABRICATION

- A. Select stone to produce pieces of thickness, size, and shape indicated, including details on Drawings and pattern specified in "Setting Stone Masonry" Article.
- B. Finish exposed stone faces and edges to comply with requirements indicated for finish and to match approved samples and mockups.

2.8 MORTAR MIXES

- A. General: Do not use admixtures, including pigments, air-entraining agents, accelerators, retarders, water-repellent agents, antifreeze compounds, or other admixtures, unless otherwise indicated.
 - 1. Do not use calcium chloride.
 - 2. Use portland cement-lime mortar unless otherwise indicated.
 - 3. Mixing Pointing Mortar: Thoroughly mix cementitious and aggregate materials together before adding water. Then mix again, adding only enough water to produce a damp, unworkable mix that will retain its form when pressed into a ball. Maintain mortar in this dampened condition for one to two hours. Add remaining water in small portions until mortar reaches required consistency. Use mortar within 30 minutes of final mixing; do not retemper or use partially hardened material.
- B. Mortar for Stone Masonry: Comply with ASTM C270, Proportion Specification.

1. Mortar for Setting Stone: Type S.
 2. Mortar for Pointing Stone: Type N.
- C. Latex-Modified Portland Cement Setting Mortar: Proportion and mix portland cement, aggregate, and latex additive to comply with latex-additive manufacturer's written instructions.
- D. Cement-Paste Bond Coat: Mix either neat cement and water or cement, sand, and water to a consistency similar to that of thick cream.
1. For latex-modified portland cement, setting-bed mortar, substitute latex admixture for part or all of water, according to latex-additive manufacturer's written instructions.
- E. Pigmented Mortar: Use colored cement product or select and proportion pigments with other ingredients to produce color required. Do not add pigments to colored cement products. Pigments shall not exceed 10 percent of portland cement by weight

PART 3 - EXECUTION

3.1 CEMENT BACKER BOARD INSTALLION

- A. Install exterior rated cement backer units in accord with cement backer unit manufacturer's installation instructions and ANSI A118.11. All elements used in the assembly must be rated for exterior use.

3.2 INSTALLATION OF AIR AND WATER BARRIER MEMBRANE

- A. Install the air and waterproofing membrane for use at stone veneer masonry in compliance with current revisions of ANSI A108.1 (2.7 Waterproofing) and ANSI A108.13. Review the installation and plan the application sequence. Pre-cut LATICRETE® Waterproofing/Anti-Fracture Fabric (if required), allowing 2" (50mm) for overlap at ends and sides to fit the areas as required. Roll up the pieces for easy handling and placement. Shake or stir LATICRETE Air and Water Barrier before using.
- B. Fill all substrate cracks, cold joints and control joints to a smooth finish using a LATICRETE latex-fortified mortar. Alternatively, a liberal coat* of LATICRETE Air and Water Barrier applied with a paint brush or trowel may be used to fill in non-structural joints and cracks. Apply a liberal coat* of LATICRETE Air and Water Barrier approximately 8" (200mm) wide over substrate cracks, cold joints, and control joints using a paint brush or heavy napped paint roller.
- C. Allow any pre-treated areas to dry to the touch. Apply a liberal coat* of LATICRETE Air and Water Barrier with a paint brush or heavy napped roller over substrate including pre-treated areas and allow to dry to the touch. Install another liberal coat* of LATICRETE Air and Water Barrier over the first coat. Let the top coat of LATICRETE Air and Water Barrier dry to the touch approximately 1 – 2 hours at 70°F (21°C) and 50% RH. When the top coat has dried to the touch inspect the surface for pinholes, voids, thin spots or other defects. LATICRETE Air

and Water Barrier will dry to an olive green color when fully cured. Use additional LATICRETE Air and Water Barrier to seal any defects.

- D. Treat Penetrations and Flashings: Allow for a minimum 1/8" (3mm) space between drains, pipes, lights, or other penetrations and surrounding adhered masonry veneer. Flash LATAPOXY Waterproof Flashing Mortar onto and around penetration openings to create a waterproof seal. Bring LATAPOXY Waterproof Flashing Mortar up to the finish level of the adhered masonry veneer, thin brick or stone finish. When LATAPOXY Waterproof Flashing Mortar has dried to the touch and the finishes have been installed, seal the gap around the penetration with LATICRETE MVIS Silicone Sealant.
- E. Movement Joints: Apply a liberal coat of LATICRETE Air and Water Barrier, approximately 8" (200mm) wide over the areas. Then embed and loop the 6" (150mm) wide LATICRETE Waterproofing/Anti-Fracture Fabric and allow the LATICRETE Air and Water Barrier liquid to bleed through. Immediately apply a second coat of LATICRETE Air and Water Barrier.
- F. Dry coat thickness is 20 to 30 mil (0.02 - 0.03" or 0.5 - 0.8mm). LATICRETE Waterproofing/Anti-Fracture Fabric is to be used to pre-treat cracks, joints, curves, corners, drains, and penetrations with LATICRETE Air and Water Barrier.
- G. Protection: Provide protection for newly installed membrane, even if covered with an adhered masonry veneer installation against exposure to rain or other water for a minimum of 2 hours at 70°F (21°C) and 50% RH. For temperatures between 45°F and 69°F (7°C to 21°C) allow a minimum 24 hour cure period.

3.3 SETTING STONE VENEER MASONRY

- A. Perform necessary field cutting and trimming as stone is set.
 - 1. Cut masonry units with wet-saw.
 - 2. Pre-soak units using clean water prior to cutting.
 - 3. Clean cut units using a stiff fiber brush and clean water. Allow units to surface dry prior to placement.
 - 4. Finish cut edges to match face when exposed in wall
- B. Sort stone before it is placed in wall to remove stone that does not comply with requirements relating to aesthetic effects, physical properties, or fabrication, or that is otherwise unsuitable for intended use.
- C. Arrange stones in random ashlar pattern matching specified manufacturer's product.
- D. Lay walls with joints not less than 1/4 inch (6 mm) at narrowest points or more than 5/8 inch (16 mm) at widest points and matching stone manufacturer's specified pattern.
- E. Provide sealant joints of widths and at locations indicated.
 - 1. Keep sealant joints free of mortar and other rigid materials.
 - 2. Sealant joints are specified in Section 079200 "Joint Sealants."

- F. Install embedded flashing at ledges, other obstructions to downward flow of water in wall, and where indicated.
1. At stud-framed walls, extend flashing through stone masonry, up sheathing face at least 8 inches (200 mm), and behind weather barrier.
 2. Install metal drip edges beneath flexible flashing at exterior wall face. Stop flexible flashing 1/2 inch (13 mm) back from exterior wall face, and adhere flexible flashing to top of metal drip edge.
 3. Install metal flashing termination beneath flexible flashing at exterior wall face. Stop flexible flashing 1/2 inch (13 mm) back from exterior wall face, and adhere flexible flashing to top of metal flashing termination.

3.4 CONSTRUCTION TOLERANCES

- A. Variation from Plumb: For vertical lines and surfaces, do not exceed 1/4 inch in 10 feet (6 mm in 3 m). For external corners do not exceed 1/4 inch in 20 feet (6 mm in 6 m).
- B. Variation of Linear Building Line: For position shown in plan, do not exceed 1/2 inch in 20 feet (13 mm in 6 m).

3.5 INSTALLATION OF ADHERED STONE MASONRY VENEER

- A. Install flashing over sheathing and behind air and water barrier membrane.
- B. General: Install in accordance with current versions of American National Standards Institute, Inc. (ANSI) "A108 American National Standard Specifications for Installation of Ceramic Tile" and TCNA "Handbook for Ceramic Tile Installation." Cut and fit adhered masonry veneer neatly around corners, fittings, and obstructions. Perimeter pieces to be minimum half unit, brick or stone. Chipped, cracked, split pieces and edges are not acceptable. Make joints even, straight, plumb and of uniform width to tolerance +/- 1/16" over 8' (1.5mm in 2.4m). Install divider strips at junction of flooring and dissimilar materials.
- C. Direct Adhere Method to Install Masonry Veneer: Install latex portland cement mortar in compliance with current revisions of ANSI A108.02 (3.11), A108.1B and ANSI A108.5. Use the appropriate trowel notch size to ensure proper bedding of the adhered masonry veneer, selected so that 100% coverage of the back surface of the Thin Adhered Veneer is achieved. Work the latex portland cement mortar into good contact with the substrate and comb with notched side of trowel. Spread only as much latex portland cement mortar as can be covered while the mortar surface is still wet and tacky. When installing large format 8" x 8" (200mm x 200mm) or larger units, spread latex portland cement mortar onto the back of ('back-butter') each piece/unit in addition to troweling latex portland cement mortar over the substrate. Beat each piece/unit into the latex portland cement mortar with a beating block or rubber mallet to insure 100% full bedding and flatness. Allow installation to set until firm. Clean excess latex portland cement mortar from adhered masonry veneer face and joints between pieces
- D. Rake out joints for pointing with mortar to depth of not less than 1/2 inch (13 mm) before setting mortar has hardened. Rake joints to uniform depths with square bottoms and clean sides.

3.6 POINTING

- A. Prepare stone-joint surfaces for pointing with mortar by removing dust and mortar particles. Where setting mortar was removed to depths greater than surrounding areas, apply pointing mortar in layers not more than 3/8 inch (10 mm) deep until a uniform depth is formed.
- B. Polymer Fortified Pointing Mortar - for joint widths $\geq 1/16''$ (1.5mm) and $\leq 1''$ (25mm]: Allow Thin Adhered veneer to cure a minimum of 24 hours @ 70° F (21°C). □ Verify joints are free of dirt, debris, wedges or spacers. Sponge or wipe dust/dirt off veneer face and remove any water standing in joints. Surface temperature must be between 40-90° F (4-32°C). Pour approximately 4 quarts (3.8 L) of clean, potable water into a clean mixing container. Add a 50 lb. (22.7 kg) bag of LATICRETE Pointing Mortar to the container while mixing. Mix by hand or with a slow speed mixer to a smooth, stiff consistency. Install latex fortified cement grout/pointing mortar in compliance with current revisions of ANSI A108.1A (7.0), ANSI A108.02 (4.5) and ANSI A108.10. Dampen dry surfaces with clean water.
- C. Place LATICRETE MVIS Pointing Mortar into a high quality masonry mortar pointing bag. Carefully bag the pointing mortar into the joints. Once the mortar has become stiff in the joint, ("thumb-print dry") typically 15-20 minutes after pointing @ 70° F (21°C), using a striking or joint tool, strike the mortar joints to the desired finish/contour. Remove excess mortar using a masonry brush or sponge. Do not over wash the mortar joint.
- D. Tool joints, when pointing mortar is thumbprint hard, with a smooth jointing tool to produce the following joint profile:
 - 1. Joint Profile: Smooth, flat face recessed 1/4 inch (6 mm) below edges of stone (raked joint).

3.7 ADJUSTING AND CLEANING

- A. In-Progress Cleaning: Clean stone masonry as work progresses. Remove mortar fins and smears before tooling joints.
- B. Final Cleaning: After mortar is thoroughly set and cured, clean stone masonry as follows:
 - 1. Remove large mortar particles by hand with wooden paddles and nonmetallic scrape hoes or chisels.
 - 2. Test cleaning methods on mockup; leave one-half of panel uncleaned for comparison purposes. Obtain Architect's approval of sample cleaning before cleaning stone masonry.
 - 3. Protect adjacent stone and non-masonry surfaces from contact with cleaner by covering them with liquid strippable masking agent, polyethylene film, or waterproof masking tape.
 - 4. Saturate masonry with clean water and flush off loose mortar and dirt.
 - 5. Clean stone masonry with proprietary acidic cleaner approved by stone manufacturer and apply according to manufacturer's written instructions.
 - 6. Clean limestone masonry to comply with recommendations in ILI's "Indiana Limestone Handbook."
 - 7. Thoroughly rinse cleaning solution and residue from wall surface.

3.8 PROTECTION

- A. Protect units from damage resulting from subsequent construction operations.
- B. Use protection materials and methods which will not stain or damage units.
- C. Remove protection materials upon Substantial Completion, or when risk of damage is no longer present.

3.9 WASTE DISPOSAL

- A. Disposal as Fill Material: Dispose of clean masonry waste, including mortar and excess or soil-contaminated sand, by crushing and mixing with fill material as fill is placed.
 - 1. Do not dispose of masonry waste as fill within 18 inches (450 mm) of finished grade.

END OF SECTION 044313.16

THIS PAGE INTENSIONALLY LEFT BLANK

SECTION 047200 - CAST STONE MASONRY

PART 1 - GENERAL

1.1 SUMMARY

A. Section Includes:

1. Cast-stone caps.

1.2 ACTION SUBMITTALS

A. Product Data: For each type of product.

1. For cast-stone units, include dimensions and finishes.

B. Shop Drawings: Show fabrication and installation details for cast-stone units. Include dimensions, details of reinforcement and anchorages if any, and indication of finished faces.

C. Samples:

1. For each color and texture of cast stone required.
2. For colored mortar.

1.3 INFORMATIONAL SUBMITTALS

A. Qualification Data: For manufacturer.

B. Material Test Reports: For each mix required to produce cast stone, based on testing according to ASTM C 1364, including test for resistance to freezing and thawing.

1.4 QUALITY ASSURANCE

A. Manufacturer Qualifications: A qualified manufacturer of cast-stone units similar to those indicated for this Project, that has sufficient production capacity to manufacture required units, and is a plant certified by the Cast Stone Institute.

PART 2 - PRODUCTS

2.1 CAST-STONE UNITS

A. Cast-Stone Units: Comply with ASTM C 1364.

1. Units shall be manufactured using the vibrant dry tamp or wet-cast method.
 2. Units shall be resistant to freezing and thawing as determined by laboratory testing according to ASTM C 666/C 666M, Procedure A, as modified by ASTM C 1364.
- B. Fabricate units with sharp arris and accurately reproduced details, with indicated texture on all exposed surfaces unless otherwise indicated.
1. Slope exposed horizontal surfaces 1:12 to drain unless otherwise indicated.
 2. Provide raised fillets at backs of sills and at ends indicated to be built into jambs.
 3. Provide drips on projecting elements unless otherwise indicated.
- C. Cure Units as Follows:
1. Cure units in enclosed, moist curing room at 95 to 100 percent relative humidity and temperature of 100 deg F (38 deg C) for 12 hours or 70 deg F (21 deg C) for 16 hours.
 2. Keep units damp and continue curing to comply with one of the following:
 - a. No fewer than five days at mean daily temperature of 70 deg F (21 deg C) or above.
 - b. No fewer than six days at mean daily temperature of 60 deg F (16 deg C) or above.
 - c. No fewer than seven days at mean daily temperature of 50 deg F (10 deg C) or above.
 - d. No fewer than eight days at mean daily temperature of 45 deg F (7 deg C) or above.
- D. Colors and Textures: As selected by Architect from manufacturer's full range.

2.2 ACCESSORIES

- A. Anchors: Type and size indicated, fabricated from steel complying with ASTM A 36/A 36M and hot-dip galvanized to comply with ASTM A 123/A 123M.
- B. Dowels: 1/2-inch- (12-mm-) diameter round bars, fabricated from steel complying with ASTM A 36/A 36M and hot-dip galvanized to comply with ASTM A 123/A 123M.
- C. Proprietary Acidic Cleaner: Manufacturer's standard-strength cleaner designed for removing mortar/grout stains, efflorescence, and other new construction stains from new masonry without discoloring or damaging masonry surfaces. Use product expressly approved for intended use by cast-stone manufacturer and expressly approved by cleaner manufacturer for use on cast stone and adjacent masonry materials.

2.3 MORTAR

- A. Comply with requirements in Section 042000 "Unit Masonry" for mortar mixes.
1. For setting mortar, use Type S.
 2. For pointing mortar, use Type N.

PART 3 - EXECUTION

3.1 SETTING CAST STONE IN MORTAR

- A. Install cast-stone units to comply with requirements in Section 042000 "Unit Masonry."
- B. Set units in full bed of mortar with full head joints unless otherwise indicated.
 - 1. Fill dowel holes and anchor slots with mortar.
 - 2. Fill collar joints solid as units are set.
 - 3. Build concealed flashing into mortar joints as units are set.
 - 4. Keep head joints in copings and between other units with exposed horizontal surfaces open to receive sealant.
 - 5. Keep joints at shelf angles open to receive sealant.
- C. Rake out joints for pointing with mortar to depths of not less than 3/4 inch (19 mm). Rake joints to uniform depths with square bottoms and clean sides. Scrub faces of units to remove excess mortar as joints are raked.
- D. Point mortar joints by placing and compacting mortar in layers not greater than 3/8 inch (10 mm). Compact each layer thoroughly and allow it to become thumbprint hard before applying next layer.
- E. Tool exposed joints slightly concave when thumbprint hard. Use a smooth plastic jointer larger than joint thickness.

3.2 SETTING ANCHORED CAST STONE WITH SEALANT-FILLED JOINTS

- A. Set cast stone as indicated on Drawings. Set units accurately in locations indicated, with edges and faces aligned according to established relationships and indicated tolerances.
 - 1. Install anchors, supports, fasteners, and other attachments indicated or necessary to secure units in place.
 - 2. Shim and adjust anchors, supports, and accessories to set cast stone in locations indicated with uniform joints.
- B. Fill anchor holes with sealant.
 - 1. Where dowel holes occur at pressure-relieving joints, provide compressible material at ends of dowels.
- C. Set cast stone supported on clip or continuous angles on resilient setting shims. Use material of thickness required to maintain uniform joint widths. Hold shims back from face of cast stone a distance at least equal to width of joint.
- D. Prepare and apply sealant of type and at locations indicated to comply with applicable requirements in Section 079200 "Joint Sealants."

3.3 INSTALLATION TOLERANCES

- A. Variation from Plumb: Do not exceed 1/8 inch in 10 feet (3 mm in 3 m), 1/4 inch in 20 feet (6 mm in 6 m), or 1/2 inch (12 mm) maximum.
- B. Variation from Level: Do not exceed 1/8 inch in 10 feet (3 mm in 3 m), 1/4 inch in 20 feet (6 mm in 6 m), or 1/2 inch (12 mm) maximum.
- C. Variation in Joint Width: Do not vary joint thickness more than 1/8 inch in 36 inches (3 mm in 900 mm) or one-fourth of nominal joint width, whichever is less.
- D. Variation in Plane between Adjacent Surfaces (Lipping): Do not vary from flush alignment with adjacent units or adjacent surfaces indicated to be flush with units by more than 1/16 inch (1.5 mm), except where variation is due to warpage of units within tolerances specified.

3.4 ADJUSTING AND CLEANING

- A. Remove and replace stained and otherwise damaged units and units not matching approved Samples. Cast stone may be repaired if methods and results are approved by Architect.
- B. Replace units in a manner that results in cast stone matching approved Samples, complying with other requirements, and showing no evidence of replacement.
- C. In-Progress Cleaning: Clean cast stone as work progresses.
 - 1. Remove mortar fins and smears before tooling joints.
 - 2. Remove excess sealant immediately, including spills, smears, and spatter.
- D. Final Cleaning: After mortar is thoroughly set and cured, clean exposed cast stone as follows:
 - 1. Remove large mortar particles by hand with wooden paddles and nonmetallic scrape hoes or chisels.
 - 2. Test cleaning methods on sample; leave one sample uncleaned for comparison purposes. Obtain Architect's approval of sample cleaning before proceeding with cleaning of cast stone.
 - 3. Protect adjacent surfaces from contact with cleaner by covering them with liquid strippable masking agent or polyethylene film and waterproof masking tape.
 - 4. Wet surfaces with water before applying cleaners; remove cleaners promptly by rinsing thoroughly with clear water.
 - 5. Clean cast stone with proprietary acidic cleaner applied according to manufacturer's written instructions.

END OF SECTION 047200

SECTION 051200 – STRUCTURAL STEEL

PART 1 - GENERAL

1.01 SUMMARY

- A. This Section includes structural steel.
- B. This Section includes structural steel and architecturally exposed structural steel.
- C. Related Sections: The following Sections contain requirements that relate to this Section:
 - 1. Division 1 Section "Quality Control" for independent testing agency procedures and administrative requirements.
 - 2. Division 5 Section "Metal Fabrications" for loose steel bearing plates and miscellaneous steel framing.

1.02 SUBMITTALS

- A. General: Submit each item in this Article according to the Conditions of the Contract and Division 1 Specification Sections.
- B. Product Data for each type of product specified.
- C. Shop Drawings detailing fabrication of structural steel components.
 - 1. Include details of cuts, connections, splices, camber, holes, and other pertinent data.
 - 2. Indicate welds by standard AWS symbols, distinguishing between shop and field welds, and show size, length, and type of each weld.
 - 3. Indicate type, size, and length of bolts, distinguishing between shop and field bolts. Identify high-strength bolted slip-critical, direct-tension, or tensioned shear/bearing connections.
- D. Qualification data for firms and persons specified in the "Quality Assurance" Article to demonstrate their capabilities and experience. Include lists of completed projects with project names and addresses, names and addresses of architects and owners, and other information specified.
- E. Mill test reports signed by manufacturers certifying that their products, including the following, comply with requirements.
 - 1. Structural steel, including chemical and physical properties.
 - 2. Bolts, nuts, and washers, including mechanical properties and chemical analysis.
 - 3. Shop primers.

4. Nonshrink grout.

1.03 QUALITY ASSURANCE

- A. Installer Qualifications: Engage an experienced Installer who has completed structural steel work similar in material, design, and extent to that indicated for this Project and with a record of successful in-service performance.
- B. Comply with applicable provisions of the following specifications and documents:
 1. AISC's "Specification for Structural Steel Buildings--Allowable Stress Design and Plastic Design."
 2. AISC's "Load and Resistance Factor Design (LFRD) Specification for Structural Steel Buildings."
 3. AISC's "Specification for Allowable Stress Design of Single-Angle Members."
 4. AISC's "Specification for Load and Resistance Factor Design of Single-Angle Members."
 5. AISC's "Seismic Provisions for Structural Steel Buildings."
 6. (ASTM A6) "Specification for General Requirements for Rolled Steel Plates, Shapes, Sheet Piling, and Bars for Structural Use."
 7. Research Council on Structural Connections' (RCSC) "Specification for Structural Joints Using ASTM A 325 or A 490 Bolts."
 8. Research Council on Structural Connections' (RCSC) "Load and Resistance Factor Design Specification for Structural Joints Using ASTM A 325 or A 490 Bolts"
- C. Welding Standards: Comply with applicable provisions of AWS D1.1 "Structural Welding Code--Steel."
 1. Present evidence that each welder has satisfactorily passed AWS qualification tests for welding processes involved and, if pertinent, has undergone recertification.
- D. Preinstallation Conference: Conduct conference at Project site to comply with requirements of Division 1 Section "Project Meetings."

1.04 DELIVERY, STORAGE, AND HANDLING

- A. Deliver structural steel to Project site in such quantities and at such times to ensure continuity of installation.
- B. Store materials to permit easy access for inspection and identification. Keep steel members off ground by using pallets, platforms, or other supports. Protect steel members and packaged materials from erosion and deterioration.

1. Store fasteners in a protected place. Clean and relubricate bolts and nuts that become dry or rusty before use.
2. Do not store materials on structure in a manner that might cause distortion or damage to members or supporting structures. Repair or replace damaged materials or structures as directed.

1.05 SEQUENCING

- A. Supply anchorage items to be embedded in or attached to other construction without delaying the Work. Provide setting diagrams, templates, instructions, and directions, as required, for installation.

PART 2 - PRODUCTS

2.01 MATERIALS

- A. Structural Steel Shapes, Plates, and Bars:
 1. ASTM Specification as indicated on the Structural Drawings.
- B. Cold-Formed Structural Steel Tubing: ASTM A 500, Grade B.
- C. Hot-Formed Structural Steel Tubing: ASTM A 501.
- D. Steel Pipe: ASTM A 53, Type E or S, Grade B.
- E. Anchor Rods, Bolts, Nuts, and Washers: As follows:
 1. Headed Bolts: ASTM A 307, Grade A; carbon-steel, hex-head bolts; and carbon-steel nuts.
 2. Washers: ASTM A 36 .
- F. Nonhigh-Strength Bolts, Nuts, and Washers: ASTM A 307, Grade A; carbon-steel, hex-head bolts; carbon-steel nuts; and flat, unhardened steel washers.
- G. High-Strength Bolts, Nuts, and Washers: ASTM A 325, Type 1, heavy hex steel structural bolts, heavy hex carbon-steel nuts, and hardened carbon-steel washers.
- H. Welding Electrodes: Comply with AWS requirements.

2.02 PRIMER

- A. Primer: Fabricator's standard lead- and chromate-free, nonasphaltic, rust-inhibiting primer.

- B. Primer: Nonasphaltic primer complying with SSPC's "Painting System Guide No. 7.00."
- C. Galvanizing Repair Paint: High-zinc-dust-content paint for regalvanizing welds and repair painting galvanized steel, with dry film containing not less than 93 percent zinc dust by weight, and complying with DOD-P-21035A or SSPC-Paint 20.

2.03 GROUT

- A. Cement Grout: Portland cement, ASTM C 150, Type I; and clean, natural sand, ASTM C 404, Size No. 2. Mix at ratio of 1 part cement to 2-1/2 parts sand, by volume, with minimum water required for placement and hydration.
- B. Metallic, Shrinkage-Resistant Grout: Premixed, factory-packaged, ferrous aggregate grout, complying with ASTM C 1107, of consistency suitable for application, and a 30-minute working time.
- C. Nonmetallic, Shrinkage-Resistant Grout: Premixed, nonmetallic, noncorrosive, non-staining grout containing selected silica sands, portland cement, shrinkage compensating agents, plasticizing and water-reducing agents, complying with ASTM C 1107, of consistency suitable for application, and a 30-minute working time.

2.04 FABRICATION

- A. Fabricate and assemble structural steel in shop to greatest extent possible. Fabricate structural steel according to AISC specifications referenced in this Section and in Shop Drawings.
 - 1. Camber structural steel members where indicated.
 - 2. Identify high-strength structural steel according to ASTM A 6 and maintain markings until steel has been erected.
 - 3. Mark and match-mark materials for field assembly.
 - 4. Fabricate for delivery a sequence that will expedite erection and minimize field handling of structural steel.
 - 5. Comply with fabrication tolerance limits of AISC's "Code of Standard Practice for Steel Buildings and Bridges" for structural steel.
- B. Fabricate architecturally exposed structural steel with exposed surfaces smooth, square, and free of surface blemishes, including pitting, rust and scale seam marks, roller marks, rolled trade names, and roughness.
 - 1. Remove blemishes by filling, grinding, or by welding and grinding, prior to cleaning, treating, and shop priming.
 - 2. Comply with fabrication requirements, including tolerance limits, of AISC's "Code of Standard Practice for Steel Buildings and Bridges" for architecturally exposed structural steel.
- C. Thermal Cutting: Perform thermal cutting by machine to greatest extent possible.

1. Plane thermally cut edges to be welded.
- D. Finishing: Accurately mill ends of columns and other members transmitting loads in bearing.
- E. Holes: Provide holes required for securing other work to structural steel framing and for passage of other work through steel framing members, as shown on Shop Drawings.
1. Cut, drill, or punch holes perpendicular to metal surfaces. Do not flame-cut holes or enlarge holes by burning. Drill holes in bearing plates.
 2. Weld threaded nuts to framing and other specialty items as indicated to receive other work.

2.05 SHOP CONNECTIONS

- A. Shop install and tighten nonhigh-strength bolts, except where high-strength bolts are indicated.
- B. Shop install and tighten high-strength bolts according to RCSC's "Specification for Structural Joints Using ASTM A 325 or A 490 Bolts."
- C. Shop install and tighten high-strength bolts according to RCSC's "Load and Resistance Factor Design Specification for Structural Joints Using ASTM A 325 or A 490 Bolts."
1. Bolts: ASTM A 325 high-strength bolts, unless otherwise indicated.
 2. Connection Type: Snug tightened, unless indicated as slip-critical, direct-tension, or tensioned shear/bearing connections.
- D. Weld Connections: Comply with AWS D1.1 for procedures, appearance and quality of welds, and methods used in correcting welding work.

2.06 GALVANIZING

- A. Hot-Dip Galvanized Finish: Apply zinc coating by the hot-dip process to structural steel indicated for galvanizing according to ASTM A 123.

PART 3 - EXECUTION

3.01 EXAMINATION

- A. Before erection proceeds, and with the steel erector present, verify elevations of concrete and masonry bearing surfaces and locations of anchorages for compliance with requirements.
- B. Do not proceed with erection until unsatisfactory conditions have been corrected.

3.02 PREPARATION

- A. Provide temporary shores, guys, braces, and other supports during erection to keep structural steel secure, plumb, and in alignment against temporary construction loads and loads equal in intensity to design loads. Remove temporary supports when permanent structural steel, connections, and bracing are in place, unless otherwise indicated.

3.03 ERECTION

- A. Set structural steel accurately in locations and to elevations indicated and according to AISC specifications referenced in this Section.
- B. Base and Bearing Plates: Clean concrete and masonry bearing surfaces of bond-reducing materials and roughen surfaces prior to setting base and bearing plates. Clean bottom surface of base and bearing plates.
 - 1. Set base and bearing plates for structural members on wedges, shims, or setting nuts as required.
 - 2. Tighten anchor bolts after supported members have been positioned and plumbed. Do not remove wedges or shims but, if protruding, cut off flush with edge of base or bearing plate prior to packing with grout.
 - 3. Pack grout solidly between bearing surfaces and plates so no voids remain. Finish exposed surfaces, protect installed materials, and allow to cure. Comply with manufacturer's instructions for proprietary grout materials.
- C. Maintain erection tolerances of structural steel within AISC's "Code of Standard Practice for Steel Buildings and Bridges."
- D. Align and adjust various members forming part of complete frame or structure before permanently fastening. Before assembly, clean bearing surfaces and other surfaces that will be in permanent contact. Perform necessary adjustments to compensate for discrepancies in elevations and alignment.
 - 1. Level and plumb individual members of structure.
 - 2. Establish required leveling and plumbing measurements on mean operating temperature of structure. Make allowances for difference between temperature at time of erection and mean temperature at which structure will be when completed and in service.
- E. Splice members only where indicated.
- F. Remove erection bolts on welded, architecturally exposed structural steel; fill holes with plug welds; and grind smooth at exposed surfaces.
- G. Do not use thermal cutting during erection.
- H. Finish sections thermally cut during erection equal to a sheared appearance.

- I. Do not enlarge unfair holes in members by burning or by using drift pins. Ream holes that must be enlarged to admit bolts.

3.04 FIELD CONNECTIONS

- A. Install and tighten nonhigh-strength bolts, except where high-strength bolts are indicated.
- B. Install and tighten high-strength bolts according to RCSC's "Specification for Structural Joints Using ASTM A 325 or A 490 Bolts."
- C. Install and tighten high-strength bolts according to RCSC's "Load and Resistance Factor Design Specification for Structural Joints Using ASTM A 325 or A 490 Bolts."
- D. Weld Connections: Comply with AWS D1.1 for procedures, appearance and quality of welds, and methods used in correcting welding work.

3.05 FIELD QUALITY CONTROL

- A. Owner will engage an independent testing and inspecting agency to perform field inspections and tests and to prepare test reports.
 1. Testing agency will conduct and interpret tests and state in each report whether tested Work complies with or deviates from requirements.
- B. Correct deficiencies in or remove and replace structural steel that inspections and test reports indicate do not comply with specified requirements.
- C. Additional testing, at Contractor's expense, will be performed to determine compliance of corrected Work with specified requirements.
- D. Field-bolted connections will be tested and inspected according to RCSC's "Specification for Structural Joints Using ASTM A 325 or A 490 Bolts."
- E. In addition to visual inspection, 20% of field-welded connections will be inspected and tested according to AWS D1.1 and the inspection procedures listed below, at testing agency's option.
 1. Liquid Penetrant Inspection: ASTM E 165.
 2. Magnetic Particle Inspection: ASTM E 709; performed on root pass and on finished weld. Cracks or zones of incomplete fusion or penetration will not be accepted.
 3. Radiographic Inspection: ASTM E 94 and ASTM E 142; minimum quality level "2-2T."
 4. Ultrasonic Inspection: ASTM E 164.

3.06 CLEANING

- A. Touchup Painting: Immediately after erection, clean field welds, bolted connections, and abraded areas of shop paint. Apply paint to exposed areas using same material as used for shop painting.
- B. Galvanized Surfaces: Clean field welds, bolted connections, and abraded areas and apply galvanizing repair paint according to ASTM A 780.

END OF SECTION

SECTION 055000 - METAL FABRICATIONS

PART 1 - GENERAL

1.1 SUMMARY

A. Section Includes:

1. Miscellaneous steel trim, framing and supports.
2. Metal ladders.
3. Elevator sump pit cover.
4. Gate hardware.
5. Loose bearing and leveling plates.
6. Weld plates.

B. Products furnished, but not installed, under this Section include the following:

1. Loose steel lintels.
2. Anchor bolts, steel pipe sleeves, slotted-channel inserts, and wedge-type inserts indicated to be cast into concrete or built into unit masonry.
3. Steel weld plates and angles for casting into concrete for applications where they are not specified in other Sections.

1.2 ACTION SUBMITTALS

A. Product Data: For the following:

1. Gate hardware.

B. Shop Drawings: Show fabrication and installation details. Include plans, elevations, sections, and details of metal fabrications and their connections. Show anchorage and accessory items. Provide gate hardware schedule.

C. Delegated-Design Submittal: For ladders, including analysis data signed and sealed by the qualified professional engineer responsible for their preparation.

PART 2 - PRODUCTS

2.1 PERFORMANCE REQUIREMENTS

- A. Delegated Design: Engage a qualified professional engineer, as defined in Section 014000 "Quality Requirements," to design ladders.

- B. Thermal Movements: Allow for thermal movements from ambient and surface temperature changes acting on exterior metal fabrications by preventing buckling, opening of joints, overstressing of components, failure of connections, and other detrimental effects.
 - 1. Temperature Change: 120 deg F (67 deg C), ambient; 180 deg F (100 deg C), material surfaces.

2.2 METALS

- A. Metal Surfaces, General: Provide materials with smooth, flat surfaces unless otherwise indicated. For metal fabrications exposed to view in the completed Work, provide materials without seam marks, roller marks, rolled trade names, or blemishes.
- B. Steel Plates, Shapes, and Bars: ASTM A 36/A 36M.
- C. Steel Pipe: ASTM A 53/A 53M, Standard Weight (Schedule 40) unless otherwise indicated.
- D. Cast Iron: Either gray iron, ASTM A 48/A 48M, or malleable iron, ASTM A 47/A 47M, unless otherwise indicated.

2.3 FASTENERS

- A. General: Unless otherwise indicated, provide Type 304 stainless-steel fasteners for exterior use and zinc-plated fasteners with coating complying with ASTM B 633 or ASTM F 1941 (ASTM F 1941M), Class Fe/Zn 5, at exterior walls. Provide Type 304 stainless-steel fasteners for dissimilar metals. Select fasteners for type, grade, and class required.
- B. Provide tamper-resistant flat-head machine screws for exposed fasteners with resilient polymer washers at exterior locations unless otherwise indicated.
- C. Cast-in-Place Anchors in Concrete: Either threaded type or wedge type unless otherwise indicated; galvanized ferrous castings, either ASTM A 47/A 47M malleable iron or ASTM A 27/A 27M cast steel. Provide bolts, washers, and shims as needed, all hot-dip galvanized per ASTM F 2329.
- D. Post-Installed Anchors: Torque-controlled expansion anchors.
 - 1. Material for Interior Locations: Carbon-steel components zinc plated to comply with ASTM B 633 or ASTM F 1941 (ASTM F 1941M), Class Fe/Zn 5, unless otherwise indicated.
 - 2. Material for Exterior Locations: Alloy Group 1 (A1) stainless-steel bolts, ASTM F 593 (ASTM F 738M), and nuts, ASTM F 594 (ASTM F 836M).

2.4 MISCELLANEOUS MATERIALS

- A. Welding Rods and Bare Electrodes: Select according to AWS specifications for metal alloy welded.

- B. Universal Shop Primer: Fast-curing, lead- and chromate-free, universal modified-alkyd primer complying with MPI#79 and compatible with topcoat.
 - 1. Use primer containing pigments that make it easily distinguishable from zinc-rich primer.
- C. Galvanizing Repair Paint: High-zinc-dust-content paint complying with SSPC-Paint 20 and compatible with paints specified to be used over it.
- D. Bituminous Paint: Cold-applied asphalt emulsion complying with ASTM D 1187/D 1187M.
- E. Nonshrink, Nonmetallic Grout: Factory-packaged, nonstaining, noncorrosive, nongaseous grout complying with ASTM C 1107/C 1107M. Provide grout specifically recommended by manufacturer for interior and exterior applications.

2.5 FABRICATION, GENERAL

- A. Shop Assembly: Preassemble items in the shop to greatest extent possible. Use connections that maintain structural value of joined pieces.
- B. Cut, drill, and punch metals cleanly and accurately. Remove burrs and ease edges. Remove sharp or rough areas on exposed surfaces.
- C. Weld corners and seams continuously to comply with the following:
 - 1. Use materials and methods that minimize distortion and develop strength and corrosion resistance of base metals.
 - 2. Obtain fusion without undercut or overlap.
 - 3. Remove welding flux immediately.
 - 4. At exposed connections, finish exposed welds and surfaces smooth and blended.
- D. Form exposed connections with hairline joints, flush and smooth, using concealed fasteners or welds where possible. Locate joints where least conspicuous.
- E. Fabricate seams and other connections that are exposed to weather in a manner to exclude water. Provide weep holes where water may accumulate.
- F. Where units are indicated to be cast into concrete or built into masonry, equip with integrally welded steel strap anchors not less than 8 inches (200 mm) from ends and corners of units and 24 inches (600 mm) o.c.

2.6 MISCELLANEOUS FRAMING AND SUPPORTS

- A. General: Provide steel framing and supports not specified in other Sections as needed to complete the Work.
- B. Fabricate units from steel shapes, plates, and bars of welded construction unless otherwise indicated. Fabricate to sizes, shapes, and profiles indicated and as necessary to receive adjacent construction.

2.7 METAL LADDERS

A. Steel Ladders:

1. Space siderails 18 inches (457 mm) apart unless otherwise indicated.
2. Siderails: Continuous, 3/8 minimum-by-2-1/2-inch (9.5-by-64-mm) steel flat bars, with eased edges.
3. Rungs: 3/4-inch- (19-mm-) diameter galvanized steel bars.
4. Fit rungs in centerline of siderails; plug-weld and grind smooth on outer rail faces.
5. Provide nonslip surfaces on top of each rung.
6. Galvanize ladders, including brackets.

2.8 ELEVATOR PIT SUMP COVERS

- A. Fabricate from 3/16-inch (4.8-mm) rolled-steel floor plate with four 1-inch- (25-mm-) diameter holes for water drainage and for lifting. Hot-dip galvanize after fabrication.

2.9 MISCELLANEOUS STEEL TRIM

- A. Unless otherwise indicated, fabricate units from steel shapes, plates, and bars of profiles shown with continuously welded joints and smooth exposed edges. Miter corners and use concealed field splices where possible.
- B. Provide cutouts, fittings, and anchorages as needed to coordinate assembly and installation with other work.
- C. Galvanize exterior miscellaneous steel trim.

2.10 FENCE GATES

- A. Hardware: Electronic latches permitting operation from both sides of gate and hinges. All hardware is to be galvanized

2.11 LOOSE BEARING AND LEVELING PLATES

- A. Provide loose bearing and leveling plates for steel items bearing on masonry or concrete construction. Drill plates to receive anchor bolts and for grouting.

2.12 STEEL WELD PLATES AND ANGLES

- A. Provide steel weld plates and angles not specified in other Sections, for items supported from concrete construction as needed to complete the Work. Provide each unit with no fewer than two integrally welded steel strap anchors for embedding in concrete.

2.13 FINISHES, GENERAL

- A. Finish metal fabrications after assembly.

2.14 STEEL AND IRON FINISHES

- A. Galvanizing: Hot-dip galvanize items as indicated to comply with ASTM A 153/A 153M for steel and iron hardware and with ASTM A 123/A 123M for other steel and iron products.
- B. Shop prime iron and steel items not indicated to be galvanized unless they are to be embedded in concrete, sprayed-on fireproofing, or masonry, or unless otherwise indicated.
 - 1. Shop prime with universal shop primer indicated.
- C. Preparation for Shop Priming: Prepare surfaces to comply with requirements indicated below:
 - 1. Exterior Items: SSPC-SP 6/NACE No. 3, "Commercial Blast Cleaning."
 - 2. Other Items: SSPC-SP 3, "Power Tool Cleaning."
- D. Shop Priming: Apply shop primer to comply with SSPC-PA 1, "Paint Application Specification No. 1: Shop, Field, and Maintenance Painting of Steel," for shop painting.

PART 3 - EXECUTION

3.1 INSTALLATION, GENERAL

- A. Cutting, Fitting, and Placement: Perform cutting, drilling, and fitting required for installing metal fabrications. Set metal fabrications accurately in location, alignment, and elevation; with edges and surfaces level, plumb, true, and free of rack; and measured from established lines and levels.
- B. Fit exposed connections accurately together to form hairline joints. Weld connections that are not to be left as exposed joints but cannot be shop welded because of shipping size limitations. Do not weld, cut, or abrade surfaces of exterior units that have been hot-dip galvanized after fabrication and are for bolted or screwed field connections.
- C. Field Welding: Comply with the following requirements:
 - 1. Use materials and methods that minimize distortion and develop strength and corrosion resistance of base metals.
 - 2. Obtain fusion without undercut or overlap.
 - 3. Remove welding flux immediately.
 - 4. At exposed connections, finish exposed welds and surfaces smooth and blended so no roughness shows after finishing and contour of welded surface matches that of adjacent surface.

- D. Fastening to In-Place Construction: Provide anchorage devices and fasteners where metal fabrications are required to be fastened to in-place construction.
- E. Provide temporary bracing or anchors in formwork for items that are to be built into concrete, masonry, or similar construction.

3.2 INSTALLING BEARING AND LEVELING PLATES

- A. Clean concrete and masonry bearing surfaces of bond-reducing materials, and roughen to improve bond to surfaces. Clean bottom surface of plates.
- B. Set bearing and leveling plates on wedges, shims, or leveling nuts. After bearing members have been positioned and plumbed, tighten anchor bolts. Do not remove wedges or shims but, if protruding, cut off flush with edge of bearing plate before packing with nonshrink grout. Pack grout solidly between bearing surfaces and plates to ensure that no voids remain.

3.3 ADJUSTING AND CLEANING

- A. Touchup Painting: Immediately after erection, clean field welds, bolted connections, and abraded areas. Paint uncoated and abraded areas with the same material as used for shop painting to comply with SSPC-PA 1 for touching up shop-painted surfaces.
- B. Galvanized Surfaces: Clean field welds, bolted connections, and abraded areas and repair galvanizing to comply with ASTM A 780/A 780M.

END OF SECTION 055000

SECTION 061000 - ROUGH CARPENTRY

PART 1 - GENERAL

1.1 SUMMARY

A. Section Includes:

1. Framing with dimension lumber.
2. Framing with engineered wood products.
3. Shear wall panels.
4. Rooftop equipment bases and support curbs.
5. Wood blocking, cants, and nailers.
6. Wood furring and grounds.
7. Plywood backing panels.

1.2 ACTION SUBMITTALS

- A. Product Data: For each type of process and factory-fabricated product.

1.3 INFORMATIONAL SUBMITTALS

- A. Material Certificates: For dimension lumber specified to comply with minimum allowable unit stresses. Indicate species and grade selected for each use and design values approved by the ALSC Board of Review.
- B. Evaluation Reports: For the following, from ICC-ES:
1. Wood-preservative-treated wood.
 2. Engineered wood products.
 3. Shear panels.
 4. Power-driven fasteners.
 5. Post-installed anchors.
 6. Metal framing anchors.

PART 2 - PRODUCTS

2.1 WOOD PRODUCTS, GENERAL

- A. Lumber: DOC PS 20 and applicable rules of grading agencies indicated. If no grading agency is indicated, comply with the applicable rules of any rules-writing agency certified by the ALSC Board of Review. Grade lumber by an agency certified by the ALSC Board of Review to inspect and grade lumber under the rules indicated.

1. Factory mark each piece of lumber with grade stamp of grading agency.
 2. For exposed lumber indicated to receive a stained or natural finish, mark grade stamp on end or back of each piece
 3. Dress lumber, S4S, unless otherwise indicated.
- B. Maximum Moisture Content of Lumber: 19 percent unless otherwise indicated.
- C. Engineered Wood Products: Acceptable to authorities having jurisdiction and for which current model code research or evaluation reports exist that show compliance with building code in effect for Project.
1. Allowable design stresses, as published by manufacturer, shall meet or exceed those indicated. Manufacturer's published values shall be determined from empirical data or by rational engineering analysis and demonstrated by comprehensive testing performed by a qualified independent testing agency.

2.2 WOOD-PRESERVATIVE-TREATED LUMBER

- A. Preservative Treatment by Pressure Process: AWWA U1; Use Category UC2 for interior construction not in contact with ground, Use Category UC3b for exterior construction not in contact with ground, and Use Category UC4a for items in contact with ground.
1. Preservative Chemicals: Acceptable to authorities having jurisdiction and containing no arsenic or chromium.
- B. Kiln-dry lumber after treatment to a maximum moisture content of 19 percent. Do not use material that is warped or that does not comply with requirements for untreated material.
- C. Mark lumber with treatment quality mark of an inspection agency approved by the ALSC Board of Review.
- D. Application: Treat items indicated on Drawings, and the following:
1. Wood cants, nailers, curbs, equipment support bases, blocking, stripping, and similar members in connection with roofing, flashing, vapor barriers, and waterproofing.
 2. Wood sills, sleepers, blocking, furring, stripping and similar concealed members in contact with masonry or concrete.
 3. Wood framing and furring attached directly to the interior of below-grade exterior masonry or concrete walls.
 4. Wood framing members that are less than 18 inches (460 mm) above the ground in crawlspaces or unexcavated areas.
 5. Wood floor plates that are installed over concrete slabs-on-grade.

2.3 DIMENSION LUMBER FRAMING

- A. Non-Load-Bearing Interior Partitions: Construction or No. 2 grade.
1. Application: Interior partitions not indicated as load bearing.

2. Species:
 - a. Southern pine or mixed southern pine; SPIB.
 - b. Northern species; NLGA.
 - c. Eastern softwoods; NeLMA.
 - d. Western woods; WCLIB or WWPA.

B. Framing Other Than Non-Load-Bearing Partitions: Construction or No. 2 grade.

1. Application: Framing other than interior partitions not indicated as load bearing.
2. Species:
 - a. Southern pine; SPIB.
 - b. Douglas fir-larch; WCLIB or WWPA.
 - c. Southern pine or mixed southern pine; SPIB.
 - d. Spruce-pine-fir; NLGA.
 - e. Douglas fir-south; WWPA.
 - f. Douglas fir-larch (north); NLGA.
 - g. Spruce-pine-fir (south); NeLMA, WCLIB, or WWPA.

C. Exposed Framing: Hand-select material for uniformity of appearance and freedom from characteristics, on exposed surfaces and edges, that would impair finish appearance, including decay, honeycomb, knot-holes, shake, splits, torn grain, and wane.

1. Species and Grade: As indicated above for load-bearing construction of same type.

2.4 ENGINEERED WOOD PRODUCTS

A. Laminated-Veneer Lumber: Structural composite lumber made from wood veneers with grain primarily parallel to member lengths, evaluated and monitored according to ASTM D5456 and manufactured with an exterior-type adhesive complying with ASTM D2559.

1. Extreme Fiber Stress in Bending, Edgewise: As indicated on the structural documents
2. Modulus of Elasticity, Edgewise: As indicated on the structural documents

B. Wood I-Joists: Prefabricated units, I-shaped in cross section, made with solid or structural composite lumber flanges and wood-based structural panel webs, let into and bonded to flanges. Comply with material requirements of and with structural capacities established and monitored according to ASTM D5055.

1. Web Material: Either OSB or plywood, complying with DOC PS 1 or DOC PS 2, Exposure 1
2. Structural Properties: Depths and design values not less than those indicated.
3. Comply with APA PRI-400. Factory mark I-joists with APA-EWS trademark indicating nominal joist depth, joist class, span ratings, mill identification, and compliance with APA-EWS standard.

C. Insulated Rim Boards: Insulated product designed to be used as a load-bearing member and to brace wood I-joists at bearing ends, complying with research/evaluation report for I-joists.

1. Manufacturer: Provide products by same manufacturer as I-joists.
2. Rim Board Material: All-veneer product or product made from any combination solid lumber, wood strands, and veneers.
3. Rim Board Thickness: 1 inch (25 mm)
4. Insulation: 1-1/2-inch- (38-mm-) thick polyisocyanurate foam complying with ASTM C1289.
5. Inside Facing: 7/16-inch- (11-mm-) thick OSB.
6. Comply with APA PRR-401, rim board grade. Factory mark rim boards with APA-EWS trademark indicating thickness, grade, and compliance with APA-EWS standard.

2.5 SHEAR WALL PANELS

- A. Wood-Framed Shear Wall Panels: Prefabricated assembly consisting of wood perimeter framing, tie downs, and Exposure I, Structural I plywood or OSB sheathing. Refer to Structural Insulated Panel Specification Section for additional information
- B. Allowable design loads, as published by manufacturer, shall meet or exceed those indicated on Manufacturer's published values shall be determined from empirical data or by rational engineering analysis and demonstrated by comprehensive testing performed by a qualified independent testing agency.

2.6 MISCELLANEOUS LUMBER

- A. General: Provide miscellaneous lumber indicated and lumber for support or attachment of other construction, including the following:
 1. Blocking.
 2. Nailers.
 3. Furring.
 4. Grounds.
- B. Dimension Lumber Items: Construction or No. 2 grade lumber of any species.
- C. Concealed Boards: 19 percent maximum moisture content and any of the following species and grades:
 1. Mixed southern pine or southern pine; No. 2 grade; SPIB.
 2. Eastern softwoods; No. 2 Common grade; NeLMA.
 3. Northern species; No. 2 Common grade; NLGA.
 4. Western woods; Construction or No. 2 Common grade; WCLIB or WWPA.

2.7 PLYWOOD BACKING PANELS

- A. Equipment Backing Panels: Plywood, DOC PS 1, in thickness indicated or, if not indicated, not less than 1/2-inch (13-mm nominal thickness).

2.8 FASTENERS

- A. General: Fasteners shall be of size and type indicated and shall comply with requirements specified in this article for material and manufacture.
 - 1. Where rough carpentry is exposed to weather, in ground contact, pressure-preservative treated, or in area of high relative humidity, provide fasteners with hot-dip zinc coating complying with ASTM A153/A153M.
- B. Power-Driven Fasteners: Fastener systems with an evaluation report acceptable to authorities having jurisdiction, based on ICC-ES AC70.
- C. Post-Installed Anchors: Fastener systems with an evaluation report acceptable to authorities having jurisdiction, based on ICC-ES ACI, CC-ES AC58, ICC-ES AC193 or ICC-ES AC308 as appropriate for the substrate.

2.9 METAL FRAMING ANCHORS

- A. Allowable design loads, as published by manufacturer, shall meet or exceed those **indicated**. Manufacturer's published values shall be determined from empirical data or by rational engineering analysis and demonstrated by comprehensive testing performed by a qualified independent testing agency. Framing anchors shall be punched for fasteners adequate to withstand same loads as framing anchors.
- B. Galvanized-Steel Sheet: Hot-dip, zinc-coated steel sheet complying with ASTM A653/A653M, G60 (Z180) coating designation.
 - 1. Use for interior locations unless otherwise indicated.
- C. Hot-Dip, Heavy-Galvanized Steel Sheet: ASTM A653/A653M; structural steel (SS), high-strength low-alloy steel Type A (HSLAS Type A), or high-strength low-alloy steel Type B (HSLAS Type B); G185 (Z550) coating designation; and not less than 0.036 inch (0.9 mm) thick.
 - 1. Use for wood-preservative-treated lumber and where indicated.

2.10 MISCELLANEOUS MATERIALS

- A. Sill-Sealer Gaskets: Closed-cell neoprene foam, 1/4 inch (6.4 mm) thick, selected from manufacturer's standard widths to suit width of sill members indicated.
- B. Adhesives for Gluing Furring to Concrete or Masonry: Formulation complying with ASTM D3498 that is approved for use indicated by adhesive manufacturer.

PART 3 - EXECUTION

3.1 INSTALLATION

- A. Framing Standard: Comply with AF&PA's WCD 1, "Details for Conventional Wood Frame Construction," unless otherwise indicated.
- B. Framing with Engineered Wood Products: Install engineered wood products to comply with manufacturer's written instructions.
- C. Set rough carpentry to required levels and lines, with members plumb, true to line, cut, and fitted. Fit rough carpentry accurately to other construction. Locate furring, nailers, blocking, grounds, and similar supports to comply with requirements for attaching other construction.
- D. Install shear wall panels to comply with manufacturer's written instructions.
- E. Install metal framing anchors to comply with manufacturer's written instructions. Install fasteners through each fastener hole.
- F. Do not splice structural members between supports unless otherwise indicated.
- G. Comply with AWPAC M4 for applying field treatment to cut surfaces of preservative-treated lumber.
- H. Where wood-preservative-treated lumber is installed adjacent to metal decking, install continuous flexible flashing separator between wood and metal decking.
- I. Securely attach rough carpentry work to substrate by anchoring and fastening as indicated, complying with the following:
 - 1. Table R602.3(1), "Fastener Schedule for Structural Members," and Table R602.3(2), "Alternate Attachments," in ICC's International Residential Code for One- and Two-Family Dwellings.
 - 2. ICC-ES evaluation report for fastener.

3.2 PROTECTION

- A. Protect wood that has been treated with inorganic boron (SBX) from weather. If, despite protection, inorganic boron-treated wood becomes wet, apply EPA-registered borate treatment. Apply borate solution by spraying to comply with EPA-registered label.
- B. Protect rough carpentry from weather. If, despite protection, rough carpentry becomes wet enough that moisture content exceeds that specified, apply EPA-registered borate treatment. Apply borate solution by spraying to comply with EPA-registered label.

END OF SECTION 061000

SECTION 061200 – STRUCTURAL INSULATED PANELS

PART 1 - GENERAL

1.1 SUMMARY

A. Section Includes:

1. Structural insulated panels (SIPs) framing system consist of oriented strand board (OSB), structural lumber and polyurethane foam, connectors and fasteners.

B. Related Requirements:

1. Section 061000 "Rough Carpentry."

1.2 REFERENCES

- A. ICC ES AC04 – Acceptance Criteria for Sandwich Panels.
- B. ICC ES AC05 – Acceptance Criteria for Sandwich Panel Adhesives.
- C. EPA - Registered products listing.

1.3 ACTION SUBMITTALS

- A. Product Data: Manufacturers' product sheet, evidence of code compliance, including current test data and listing report, calculations by a professional engineer.
- B. Shop Drawings: Manufacture to provide complete panel shop drawings, showing all panel sizes, electrical layout, door and window openings and any other structural elements.
- C. Calculations: Provide structural calculations by a professional engineer registered in the Commonwealth of Virginia and qualified to perform such work.

1.4 INFORMATIONAL SUBMITTALS

A. Material Certificates:

1. Product certificate showing compliance to Third Party Quality Control program.

B. Manufacturer's Instructions: SIP Manufacturer's construction detail book and load design charts.

C. Warranty: Sample warranty documents.

1.5 QUALITY ASSURANCE

- A. Installer Qualifications: Installer should be experienced in performing work of this section and should have specialized in installation of work similar to that required for this project.
- B. Source Limitations: Obtain all SIPs through one source. All accessories to be as furnished or recommended by the SIP manufacturer.
 - 1. Each SIP shall be labeled indicating Third Party certification.
 - 2. Provide evidence of Third Party inspection and labeling of all insulation used in manufacture of SIPs.
 - 3. Dimensional Tolerance - shall comply with values listed in the manufacturer's Quality Control Manual.
- C. Regulatory requirements: SIPs shall be recognized for compliance with International Residential Code in a current third party listing report.
- D. Pre-installation Meeting: Conduct pre-installation meeting to verify project requirements, foundation/structural system/substrate conditions, SIP manufacturer's installation instructions and SIP manufacturer's warranty requirements. Comply with Division 1 Project Management and Coordination (Project Meetings) Section.

1.6 DELIVERY, STORAGE, AND HANDLING

- A. Delivery: Deliver materials from SIP manufacturer with identification labels or markings intact.
- B. Off-load SIPs from truck and handle using forklift or other means to prevent damage to SIPs.
- C. SIPs shall be fully supported in storage and prevented from contact with the ground.
- D. SIPs shall be fully protected from weather. Protect against exposure to rain, water, dirt, mud, and other residue that may affect SIP performance. Cover stored SIPs with breathable protective wraps. SIPs shall be stored in a protected area.

1.7 WARRANTY

- A. Manufacturer's Warranty: Submit SIP manufacturer's standard warranty document. SIP Manufacturer's warranty is in addition to, and not a limitation of, other rights Owner may have under Contract Documents.
 - 1. Warranty Period: 10 years commencing on Date of Substantial Completion

PART 2 - PRODUCTS

2.1 MANUFACTURERS

- A. Thermocore Panel System, 1801 Hancel Parkway, Mooresville, IN 46158
www.thermomore.com or approved equivalent.

2.2 MATERIALS

- A. Structural Insulated Panels consisting of the following:
1. 6-1/2" thick wall foam core panels and 8-1/4" thick roof foam core panels with 7/16" OSB/OSB (interior/exterior) skins. Each panel has a foam core of class 1/A fire-rated polyurethane foam at a minimum density of 2.2 lbs.
 2. OSB identified with APA or PFS performance mark with Exposure I durability rating and performance in accordance with DOC PS-2 span rating 24/16 or greater.
 3. All panels are manufactured to a thickness tolerance of +/- 3/8".
 4. All lumber used in panel manufacturing shall be #2 or better SPF.
- B. Maximum Moisture Content:
1. Boards: 19 percent.
 2. Dimension Lumber: 19 percent.

2.3 ACCESSORIES

- A. SIP Gasket. Foam Gasket shall be provided by the SIP manufacturer.
- B. Dimension Lumber: SPF No. 2 or better.

2.4 FABRICATION

- A. Sizes: SIPs shall be fabricated in accordance with approved Shop Drawings.
- B. Thermal Resistance, R-value:
1. 6 1/2" thick wall SIP with R-value of 40.
 2. 8 1/4" thick roof SIP with R-value of 50

2.5 FASTENERS

- A. General: Provide fasteners of size and type indicated, acceptable to authorities having jurisdiction, and that comply with requirements specified in this article for material and manufacture. Provide nails or screws, in sufficient length, to penetrate not less than 1-1/2 inches (38 mm) into wood substrate.

1. Use stainless steel wood screws for attachment to wood members unless otherwise indicated.
- B. Postinstalled Anchors: Stainless steel, torque-controlled expansion anchors with capability to sustain, without failure, a load equal to 6 times the load imposed when installed in unit masonry assemblies and equal to 4 times the load imposed when installed in concrete as determined by testing according to ASTM E488, conducted by a qualified independent testing and inspecting agency.
 1. Stainless steel bolts and nuts complying with ASTM F593 and ASTM F594, Alloy Group 1 or 2 (ASTM F738M and ASTM F836M, Grade A1 or Grade A4).

PART 3 - EXECUTION

3.1 MANUFACTURER'S INSTRUCTIONS

- A. Compliance: Comply with manufacturer's listing report, Load Design Charts, Detail Book, Shop Drawings, and product data. for installation.
- B. Plans shall be reviewed by a qualified architect/engineer and shall be signed and/or sealed. Deviations from standard detail and load design values shall be calculated and signed and/or sealed by a qualified professional engineer

3.2 EXAMINATION

- A. Verify conditions of foundation/structural system/substrate and other conditions that affect installation of SIPs. Any adverse conditions shall be reported in writing. Do not proceed with installation until adverse conditions are corrected.

3.3 INSTALLATION

- A. Set work to required levels and lines, with members plumb, true to line, cut, and fitted. Fit work to other construction; scribe and cope as needed for accurate fit.
- B. Structural Insulated Panel installation:
 1. SIP Supports: Provide level and square foundation/structural system/substrate that support wall and/or roof SIPs. For wall SIPs, hold sill plate back from edge of rim board 7/16" (11 mm) to allow full bearing of OSB skins. Provide 1 1/2" (38 mm) diameter access holes in plating to align with electrical conduit SIPs. Provide adequate bracing of SIPs during erection. Remove debris from plate area prior to SIP placement.
 2. SIP Fastening: Connect SIPs by nails or staples as shown on drawings. Screws of equal strength may be substituted for nails and staples as specified by engineer. SIP sealant gasket must be used together with each fastening techniques. Where SIP Screw Fasteners are used, provide a minimum of 1" (25.4 mm) penetration into support. Join SIPs using

tongue and groove. Secure attachment with nails, staples, or screws. Apply foam sealant gasket as per SIP manufacturer recommendations.

3. Thermal Barriers: Interior surfaces of SIPs shall be finished with a minimum 15-minute thermal barrier consisting of 5/8" (10 mm) gypsum board. Apply thermal barrier according to SIP manufacturer's recommendations.
4. Restrictions: Do not install SIPs directly on concrete. Do not cut or alter SIPs without consulting SIP manufacturer. SIPs shall be protected from exposure UV light and moisture.
5. Remove and replace insulated wall or roof SIPs that have become wet to the point of saturation or damaged before proceeding with installation of additional SIPs or other work.

3.4 PROTECTION

- A. Protection: Protect installed product and finish surfaces from damage during construction.
 1. Roof SIPs: Protect roof SIPs from weather at all times. Provide temporary protection at the end of the day or when rain or snow is imminent.
 2. After installation, cover SIPs to prevent contact with water on each exposed SIP edges and faces. Failure to do so can result in edge swelling and rejection of panel installation.

END OF SECTION 061200

THIS PAGE LEFT INTENSIONALLY BLANK

SECTION 061600 - SHEATHING

PART 1 - GENERAL

1.1 SUMMARY

A. Section Includes:

1. Wall sheathing.
2. Roof sheathing.
3. Parapet sheathing.
4. Subflooring.
5. Underlayment.

1.2 ACTION SUBMITTALS

- A. Product Data: For each type of process and factory-fabricated product.

1.3 INFORMATIONAL SUBMITTALS

A. Evaluation Reports: For the following, from ICC-ES:

1. Wood-preservative-treated plywood.
2. Foam-plastic sheathing.

1.4 QUALITY ASSURANCE

PART 2 - PRODUCTS

2.1 WOOD PANEL PRODUCTS

- A. Emissions: Products shall meet the testing and product requirements of the California Department of Public Health's "Standard Method for the Testing and Evaluation of Volatile Organic Chemical Emissions from Indoor Sources Using Environmental Chambers."

2.2 PRESERVATIVE-TREATED PLYWOOD

- A. Preservative Treatment by Pressure Process: AWPA U1; Use Category UC2 for interior construction not in contact with ground, Use Category UC3b for exterior construction not in contact with ground, and Use Category UC4a for items in contact with ground.

- B. Mark plywood with appropriate classification marking of an inspection agency acceptable to authorities having jurisdiction.
- C. Application: Treat items indicated on Drawings and plywood in contact with masonry or concrete or used with roofing, flashing, vapor barriers, and waterproofing.

2.3 WALL SHEATHING

- A. Plywood Sheathing: Exterior, Structural I sheathing.
- B. Oriented-Strand-Board Sheathing: DOC PS 2, Exposure 1, Structural I sheathing.

2.4 ROOF SHEATHING

- A. Plywood Sheathing: Exterior, Structural I sheathing.
- B. Oriented-Strand-Board Sheathing: DOC PS 2, Exposure 1, Structural I sheathing.

2.5 PARAPET SHEATHING

- A. Plywood Sheathing: Exterior, Structural I sheathing.
- B. Oriented-Strand-Board Sheathing: DOC PS 2, Exposure 1, Structural I sheathing.

2.6 SUBFLOORING AND UNDERLAYMENT

- A. Plywood Combination Subfloor-Underlayment: DOC PS 1, tongue and groove, single-floor panels. Provide 3/4 in thick unless noted otherwise.
- B. Underlayment: Provide underlayment only where indicated and not less than 1/4 inch (6.4 mm) over smooth subfloors. Plywood underlayment is not required where gypsum cement underlayment is provided.
 - 1. Plywood Underlayment for Resilient Flooring: DOC PS 1, with fully sanded face.
 - 2. Plywood Underlayment for Ceramic Tile: DOC PS 1, Exterior, C-C Plugged, not less than 5/8-inch (15.9-mm) nominal thickness.

2.7 FASTENERS

- A. General: Provide fasteners of size and type indicated that comply with requirements specified in this article for material and manufacture.
 - 1. For roof parapet and wall sheathing, provide fasteners with hot-dip zinc coating complying with ASTM A153/A153M.

2. For roof parapet and wall sheathing, provide fasteners with organic-polymer or other corrosion-protective coating having a salt-spray resistance of more than 800 hours according to ASTM B117.

2.8 MISCELLANEOUS MATERIALS

- A. Adhesives for Field Gluing Panels to Wood Framing: Formulation complying with ASTM D3498 that is approved for use with type of construction panel indicated by manufacturers of both adhesives and panels.

PART 3 - EXECUTION

3.1 INSTALLATION, GENERAL

- A. Do not use materials with defects that impair quality of sheathing or pieces that are too small to use with minimum number of joints or optimum joint arrangement. Arrange joints so that pieces do not span between fewer than three support members.
- B. Cut panels at penetrations, edges, and other obstructions of work; fit tightly against abutting construction unless otherwise indicated.
- C. Securely attach to substrate by fastening as indicated, complying with the following:
 1. Table R602.3(1), "Fastener Schedule for Structural Members," and Table R602.3(2), "Alternate Attachments," in the ICC's International Residential Code for One- and Two-Family Dwellings.
 2. ICC-ES evaluation report for fastener.
- D. Coordinate wall, parapet and roof sheathing installation with flashing and joint-sealant installation so these materials are installed in sequence and manner that prevent exterior moisture from passing through completed assembly.
- E. Do not bridge building expansion joints; cut and space edges of panels to match spacing of structural support elements.

3.2 WOOD STRUCTURAL PANEL INSTALLATION

- A. General: Comply with applicable recommendations in APA Form No. E30, "Engineered Wood Construction Guide," for types of structural-use panels and applications indicated.
- B. Fastening Methods: Fasten panels as indicated below:
 1. Combination Subfloor-Underlayment:
 - a. Glue and nail to wood framing.
 - b. Space panels 1/8 inch (3 mm) apart at edges and ends.

2. Subflooring:
 - a. Glue and nail to wood framing.
 - b. Space panels 1/8 inch (3 mm) apart at edges and ends.
3. Wall and Roof Sheathing:
 - a. Nail to wood framing. Apply a continuous bead of glue to framing members at edges of wall sheathing panels.
 - b. Space panels 1/8 inch (3 mm) apart at edges and ends.
4. Underlayment:
 - a. Nail to subflooring.
 - b. Space panels 1/32 inch (0.8 mm) apart at edges and ends.
 - c. Fill and sand edge joints of underlayment receiving resilient flooring immediately before installing flooring.

END OF SECTION 061600

SECTION 062013 - EXTERIOR FINISH CARPENTRY

PART 1 - GENERAL

1.1 SUMMARY

A. Section Includes:

1. Exterior cellular PVC and aluminum railing system.

B. Related Requirements:

1. Section 061000 "Rough Carpentry".
2. Section 074646 "Fiber-Cement Siding" for exterior siding, trim boards and soffit boards.

1.2 ACTION SUBMITTALS

A. Product Data: For each type of process and factory-fabricated product.

B. Samples: For each type of product involving selection of colors, profiles, or textures.

1.3 INFORMATIONAL SUBMITTALS

A. Evaluation Reports: For the following, from ICC-ES:

1. Cellular PVC trim.

1.4 DELIVERY, STORAGE, AND HANDLING

A. Deliver and store packaged materials in original containers with labels intact until time of use.

B. Store materials on elevated platforms, under cover, and in a dry location.

PART 2 - PRODUCTS

2.1 EXTERIOR RAILING

A. Cellular PVC Railing System: Extruded, expanded PVC with a small-cell microstructure, recommended by manufacturer for exterior use, made from UV- and heat-stabilized rigid material. Round balusters are manufacture's standard black prefinished aluminum

1. Manufacturers: Subject to compliance with requirements, provide products by the following or approved equivalent:

- a. Trex Company, Inc., www.trex.com, Trex Select Railing.
2. Cellular PVC Properties:
 - a. Density: Not less than 31 lb/cu. ft. (500 kg/cu. m).
 - b. Water Absorption: Not more than 1 percent, according to ASTM D 570.
 - c. Flame-Spread Index: 75 or less, according to ASTM E 84.
3. Provide wall mounted cellular PVC handrail to match system with galvanized and painted wall brackets.

2.2 MISCELLANEOUS MATERIALS

- A. Fasteners for Exterior Finish Carpentry: Provide nails or screws, in sufficient length to penetrate not less than 1-1/2 inches (38 mm) into wood substrate.
 1. For prefinished items, provide matching prefinished aluminum fasteners where face fastening is required.
- B. Sealants: Latex, complying with ASTM C 834 Type OP, Grade NF and applicable requirements in Section 079200 "Joint Sealants" and recommended by sealant and substrate manufacturers for intended application.

PART 3 - EXECUTION

3.1 INSTALLATION, GENERAL

- A. Install exterior finish carpentry level, plumb, true, and aligned with adjacent materials. Use concealed shims where necessary for alignment.
 1. Scribe and cut exterior finish carpentry to fit adjoining work. Refinish and seal cuts as recommended by manufacturer.

3.2 RAILING SYSTEM INSTALLATION

- A. Install complete railing system to comply with manufacturer's written instructions.
- B. Install with minimum number of joints as is practical, using full-length pieces from maximum lengths of lumber available. Do not use pieces less than 24 inches (610 mm) long, except where necessary.
- C. Install handrail into wood blocking anchored to foundation wall with expansion bolts.
- D. Fit exterior joints to exclude water. Cope at returns and miter at corners to produce tight-fitting joints, with full-surface contact throughout length of joint.

END OF SECTION 062013

SECTION 064023 - INTERIOR ARCHITECTURAL WOODWORK

PART 1 - GENERAL

1.1 SUMMARY

A. Section Includes:

1. Interior frames and jambs.
2. Interior stairs and railings.
3. Wood furring, blocking, shims, and hanging strips for installing interior architectural woodwork items that are not concealed within other construction.
4. Shop priming of interior architectural woodwork.

1.2 PREINSTALLATION MEETINGS

- A. Preinstallation Conference: Conduct conference at Project site.

1.3 ACTION SUBMITTALS

A. Product Data: For the following:

1. Anchors.
2. Adhesives.
3. Shop finishing materials.

B. Shop Drawings:

1. Include the following:
 - a. Dimensioned plans, elevations, and sections.
 - b. Attachment and construction details.
2. Show locations and sizes of furring, blocking, and hanging strips, including blocking and reinforcement concealed by construction and specified in other Sections.
3. Apply AWI Quality Certification Program label to Shop Drawings.

- C. Samples: For each exposed product and for each shop-applied color and finish specified.

1.4 QUALITY ASSURANCE

- A. Manufacturer's Certification: Licensed participant in AWI's Quality Certification Program.

- B. Installer Qualifications: Licensed participant in AWI's Quality Certification Program.

1.5 DELIVERY, STORAGE, AND HANDLING

- A. Comply with the Architectural Woodwork Standards, Section 2.
- B. Do not deliver interior architectural woodwork until painting and similar finish operations that might damage woodwork have been completed in installation areas.
- C. Store woodwork in installation areas or in areas where environmental conditions comply with requirements specified in "Field Conditions" Article.
 - 1. Handle and store fire-retardant-treated wood to comply with chemical treatment manufacturer's written instructions.

1.6 FIELD CONDITIONS

- A. Environmental Limitations: Do not deliver or install interior architectural woodwork until building is enclosed, wet-work is complete, and HVAC system is operating and maintaining temperature and relative humidity at levels designed for building occupants for the remainder of the construction period.
- B. Environmental Limitations: Do not deliver or install interior architectural woodwork until building is enclosed, wet-work is complete, and HVAC system is operating and maintaining temperature between 60 and 90 deg F (16 and 32 deg C) and relative humidity between 43 and 70 percent during the remainder of the construction period.
- C. Field Measurements: Where interior architectural woodwork is indicated to fit to other construction, verify dimensions of other construction by field measurements before fabrication, and indicate measurements on Shop Drawings.

PART 2 - PRODUCTS

2.1 ARCHITECTURAL WOODWORK, GENERAL

- A. Quality Standard: Unless otherwise indicated, comply with the Architectural Woodwork Standards for grades of interior architectural woodwork indicated for construction, finishes, installation, and other requirements.

2.2 INTERIOR STANDING AND RUNNING TRIM FOR TRANSPARENT FINISH

- A. Architectural Woodwork Standards Grade: Premium.
- B. Hardwood Lumber:
 - 1. Species: White oak.
 - 2. Cut: Plain sliced/plain sawn.
 - 3. Wood Moisture Content: 5 to 10 percent.

4. For rails and trim thicker than available lumber, use veneered construction. Do not glue for thickness.

2.3 INTERIOR FRAMES AND JAMBS FOR OPAQUE FINISH

- A. Architectural Woodwork Standards Grade: Premium.
- B. Wood Species: Any closed-grain hardwood.
 1. Do not use plain-sawn softwood lumber with exposed, flat surfaces more than 3 inches (76 mm) wide.
 2. Wood Moisture Content: 5 to 10 percent.

2.4 INTERIOR WOOD STAIRS AND RAILINGS

- A. Architectural Woodwork Standards Grade: Premium.
- B. Balusters: 1 inch diameter round, wrought iron, painted.
- C. Wood for Transparent Finish:
 1. Species and cut:
 - a. Treads: Red oak, plain sawn.
 - b. Railings: Red oak, plain sawn.
 2. Wood Moisture Content: 5 to 10 percent.
- D. Wood for Opaque Finish:
 1. Species: Any closed-grain hardwood.
 2. Wood Moisture Content: 5 to 10 percent.
- E. Rough Carriages for Stairs: No. 1 grade, kiln-dried to 15 percent maximum moisture content:
 1. Acceptable Species:
 - a. Hem-fir (north).
 - b. Southern pine.
 - c. Douglas fir-larch.
 - d. Douglas fir-larch (north).
 - e. Spruce-pine-fir.
 - f. Hem-fir.
 - g. Douglas fir-south.
 - h. Spruce-pine-fir (south).
- F. Finishes for Stair Parts:
 1. Treads: Transparent.

2. Risers: Opaque.
3. Stringers: Opaque.
4. Handrails: Transparent.
5. Scotia, Cove, and Other Moldings: Opaque.

- G. Handrail Brackets: Cast stainless steel with wall flange drilled and tapped for concealed hanger bolt and with support arm for screwing to underside of rail. Size to provide 1-1/2-inch (38-mm) clearance between handrail and face of wall.

2.5 HARDWOOD SHEET MATERIALS

- A. Composite Wood Products: Provide materials that comply with requirements of the Architectural Woodwork Standards for each type of interior architectural woodwork and quality grade specified unless otherwise indicated.
1. Softwood Plywood: DOC PS 1, medium-density overlay.
 2. Veneer-Faced Panel Products (Hardwood Plywood): HPVA HP-1.

2.6 MISCELLANEOUS MATERIALS

- A. Furring, Blocking, Shims, and Nailers: Fire-retardant-treated softwood lumber, kiln-dried to less than 15 percent moisture content.
1. Fire-Retardant Treatment: Complying with requirements; provide where indicated.
- B. Provide self-drilling screws for metal-framing supports, as recommended by metal-framing manufacturer.
- C. Anchors: Select material, type, size, and finish required for each substrate for secure anchorage.
1. Provide metal expansion sleeves or expansion bolts for post-installed anchors.
 2. Use nonferrous-metal or hot-dip galvanized anchors and inserts at inside face of exterior walls and at floors.
- D. Installation Adhesive: Product recommended by fabricator for each substrate for secure anchorage.

2.7 FABRICATION

- A. Fabricate interior architectural woodwork to dimensions, profiles, and details indicated.
1. Ease edges to radius indicated for the following:
 - a. Edges of Solid-Wood (Lumber) Members: 1/16 inch (1.5 mm) unless otherwise indicated.
 - b. Edges of Rails and Similar Members More Than 3/4 Inch (19 mm) Thick: 1/8 inch (3 mm).

- B. Complete fabrication, including assembly, to maximum extent possible before shipment to Project site.
 - 1. Disassemble components only as necessary for shipment and installation.
 - 2. Where necessary for fitting at site, provide allowance for scribing, trimming, and fitting.
 - 3. Trial fit assemblies at fabrication shop that cannot be shipped completely assembled.
 - a. Install dowels, screws, bolted connectors, and other fastening devices that can be removed after trial fitting.
 - b. Verify that parts fit as intended, and check measurements of assemblies against field measurements indicated on approved Shop Drawings before disassembling for shipment.

- C. Stairs: Cut rough carriages to accurately fit treads and risers.
 - 1. Glue treads to risers, and glue and nail treads and risers to carriages.
 - 2. House wall and face stringers, and glue and wedge treads and risers.
 - 3. Fabricate stairs with treads and risers no more than 1/8 inch (3 mm) from indicated position and no more than 1/16 inch (1.5 mm) out of relative position for adjacent treads and risers.

2.8 SHOP PRIMING

- A. Preparations for Finishing: Comply with the Architectural Woodwork Standards for sanding, filling countersunk fasteners, sealing concealed surfaces, and similar preparations for finishing interior architectural woodwork, as applicable to each unit of work.

- B. Interior Architectural Woodwork for Opaque Finish: Shop prime with one coat of wood primer as specified in Section 099123 "Interior Painting."
 - 1. Backpriming: Apply one coat of primer, compatible with finish coats, to concealed surfaces of woodwork.

- C. Interior Architectural Woodwork for Transparent Finish: Shop-seal concealed surfaces with required pretreatments and first coat of finish as specified in Section 099300 "Staining and Transparent Finishing."
 - 1. Backpriming: Apply one coat of sealer, compatible with finish coats, to concealed surfaces of woodwork.

PART 3 - EXECUTION

3.1 PREPARATION

- A. Before installation, condition interior architectural woodwork to humidity conditions in installation areas for not less than 72 hours prior to beginning of installation.

- B. Before installing interior architectural woodwork, examine shop-fabricated work for completion and complete work as required, including removal of packing and backpriming of concealed surfaces.

3.2 INSTALLATION

- A. Grade: Install interior architectural woodwork to comply with same grade as item to be installed.
- B. Assemble interior architectural woodwork and complete fabrication at Project site to the extent that it was not completed during shop fabrication.
- C. Install interior architectural woodwork level, plumb, true in line, and without distortion.
 - 1. Shim as required with concealed shims.
 - 2. Install level and plumb to a tolerance of 1/8 inch in 96 inches (3 mm in 2400 mm).
- D. Scribe and cut interior architectural woodwork to fit adjoining work, refinish cut surfaces, and repair damaged finish at cuts.
- E. Anchor interior architectural woodwork to anchors or blocking built in or directly attached to substrates.
 - 1. Secure with countersunk, concealed fasteners and blind nailing.
 - 2. Use fine finishing nails or finishing screws for exposed fastening, countersunk and filled flush with interior architectural woodwork.
- F. Standing and Running Trim:
 - 1. Install with minimum number of joints possible, using full-length pieces (from maximum length of lumber available) to greatest extent possible.
 - 2. Do not use pieces less than 60 inches (1500 mm) long, except where shorter single-length pieces are necessary.
 - 3. Scarf running joints and stagger in adjacent and related members.
 - 4. Fill gaps, if any, between top of base and wall with latex sealant, painted to match wall.
 - 5. Install standing and running trim with no more variation from a straight line than 1/8 inch in 96 inches (3 mm in 2400 mm).
- G. Stairs: Securely anchor carriages to supporting substrates.
 - 1. Install stairs with treads and risers no more than 1/8 inch (3 mm) from indicated position.
 - 2. Secure with countersunk, concealed fasteners and blind nailing.
 - 3. Use fine finishing nails or finishing screws for exposed fastening, countersunk and filled flush with wood surface.
- H. Railings:
 - 1. Install rails with no more than 1/8 inch in 96-inch (3 mm in 2400-mm) variation from a straight line.

2. Stair Rails: Glue and dowel or pin balusters to treads and railings, and railings to newel posts.
 - a. Secure with countersunk, concealed fasteners and blind nailing.
 - b. Use fine finishing nails or finishing screws for exposed fastening, countersunk and filled flush with wood surface.
3. Wall Rails: Support rails on wall brackets securely fastened to wall framing.
 - a. Space rail brackets not more than 6 feet o.c.

END OF SECTION 064023

THIS PAGE INTENSIONALLY LEFT BLANK

SECTION 064113 - WOOD-VENEER-FACED ARCHITECTURAL CABINETS

PART 1 - GENERAL

1.1 SUMMARY

A. Section Includes:

1. Wood cabinets for transparent finish.
2. Cabinet hardware and accessories.
3. Wood furring, blocking, shims, and hanging strips for installing architectural cabinets that are not concealed within other construction.
4. Shop finishing.

1.2 PREINSTALLATION MEETINGS

- A. Preinstallation Conference: Conduct conference at Project site.

1.3 ACTION SUBMITTALS

- A. Product Data: For each type of product.

- B. Shop Drawings: For architectural cabinets.

1. Include plans, elevations, sections, and attachment details.
2. Apply AWI Quality Certification Program label to Shop Drawings.

- C. Samples: For each exposed product and for each color and finish specified.

1.4 INFORMATIONAL SUBMITTALS

- A. Qualification Data: For manufacturer and Installer.

1.5 CLOSEOUT SUBMITTALS

- A. Quality Standard Compliance Certificates: AWI Quality Certification Program certificates.

1.6 QUALITY ASSURANCE

- A. Manufacturer's Qualifications: Employs skilled workers who custom fabricate products similar to those required for this Project and whose products have a record of successful in-service performance.

1. Manufacturer's Certification: Licensed participant in AWI's Quality Certification Program.
- B. Installer Qualifications: Licensed participant in AWI's Quality Certification Program.

PART 2 - PRODUCTS

2.1 WOOD CABINETS FOR TRANSPARENT FINISH

- A. Quality Standard: Unless otherwise indicated, comply with the Architectural Woodwork Standards for grades of architectural cabinets indicated for construction, finishes, installation, and other requirements.
- B. Architectural Woodwork Standards Grade: Premium.
- C. Type of Construction: Face frame.
- D. Door and Drawer-Front Style: Shaker style.
 1. Reveal Dimension: 1-3/4 inch (13 mm) rails and stiles.
- E. Wood for Exposed Surfaces:
 1. Species: Maple.
 2. Cut: Plain sliced/plain sawn.
 3. Grain Direction: Vertically for doors and fixed panels, horizontally for drawer fronts.
 4. Matching of Veneer Leaves: Random match.
 5. Veneer Matching within Panel Face: Center-balance match.
- F. Drawer Construction: Fabricate with exposed fronts fastened to subfront with mounting screws from interior of body.
 1. Join subfronts, backs, and sides with glued rabbeted joints supplemented by mechanical fasteners or glued dovetail joints.

2.2 WOOD MATERIALS

- A. Wood Products: Provide materials that comply with requirements of referenced quality standard for each type of architectural cabinet and quality grade specified unless otherwise indicated.
 1. Do not use plain-sawn softwood lumber with exposed, flat surfaces more than 3 inches (75 mm) wide.
 2. Wood Moisture Content: 5 to 10 percent.
- B. Composite Wood Products: Provide materials that comply with requirements of referenced quality standard for each type of architectural cabinet and quality grade specified unless otherwise indicated.

1. Particleboard (Medium Density): ANSI A208.1, Grade M-2-Exterior Glue.
2. Softwood Plywood: DOC PS 1, medium-density overlay.
3. Veneer-Faced Panel Products (Hardwood Plywood): HPVA HP-1.
4. Thermoset Decorative Panels: Particleboard or MDF finished with thermally fused, melamine-impregnated decorative paper and complying with requirements of NEMA LD 3, Grade VGL, for Test Methods 3.3, 3.4, 3.6, 3.8, and 3.10. Provide for concealed locations only.

2.3 CABINET HARDWARE AND ACCESSORIES

- A. General: Provide cabinet hardware and accessory materials associated with architectural cabinets except for items specified in Section 087100 "Door Hardware." Refer to Casework Hardware Specs, Sheet A720 for specific products required.
- B. Concealed Hinges (European Type) Full Overlay: ANSI/BHMA A156.9, B01602, 110 degrees of opening, self-closing.
- C. Wire Bar Pulls: Back mounted, solid metal, 5/16 inch (8 mm) in diameter, length varies, refer to Interior Elevations and Interior Details on drawings..
- D. Catches: Push-in magnetic catches, BHMA A156.9, B03131.
- E. Adjustable Shelf Standards and Supports: BHMA A156.9, B04071; with shelf rests, B04081.
- F. Shelf Rests: BHMA A156.9, B04013; metal.
- G. Drawer Slides: BHMA A156.9.
 1. Grade 1: Side mounted.
 - a. Type: Full extension.
 - b. Material: Zinc-plated steel with polymer rollers.
 2. Grade 1HD-100: Side mounted; full-extension type; zinc-plated-steel ball-bearing slides.
 3. For drawers not more than 3 inches (75 mm) high and not more than 24 inches (600 mm) wide, provide Grade 1.
 4. For drawers more than 3 inches (75 mm) high, but not more than 6 inches (150 mm) high and not more than 24 inches (600 mm) wide, provide Grade 1.
 5. For drawers more than 6 inches (150 mm) high or more than 24 inches (600 mm) wide, provide Grade 1HD-100.
 6. For trash bins not more than 20 inches (500 mm) high and 16 inches (400 mm) wide, provide Grade 1HD-100.
- H. Door Locks: BHMA A156.11, E07121.
- I. Drawer Locks: BHMA A156.11, E07041.
- J. Door and Drawer Silencers: BHMA A156.16, L03011.

- K. Exposed Hardware Finishes: For exposed hardware, provide finish that complies with BHMA A156.18 for BHMA finish number indicated.
 - 1. Satin Nickel (US15) and Flat Black (US19): BHMA 626 for brass or bronze base; BHMA 652 for steel base.
 - 2. Black Onyx.
- L. For concealed hardware, provide manufacturer's standard finish that complies with product class requirements in BHMA A156.9.

2.4 MISCELLANEOUS MATERIALS

- A. Furring, Blocking, Shims, and Hanging Strips: Softwood or hardwood lumber, kiln-dried to less than 15 percent moisture content.
- B. Anchors: Select material, type, size, and finish required for each substrate for secure anchorage. Provide metal expansion sleeves or expansion bolts for post-installed anchors. Use nonferrous-metal or hot-dip galvanized anchors and inserts at inside face of exterior walls and at floors.

2.5 FABRICATION

- A. Sand fire-retardant-treated wood lightly to remove raised grain on exposed surfaces before fabrication.
- B. Complete fabrication, including assembly and hardware application, to maximum extent possible before shipment to Project site. Disassemble components only as necessary for shipment and installation. Where necessary for fitting at site, provide ample allowance for scribing, trimming, and fitting.
- C. Shop-cut openings to maximum extent possible to receive hardware, appliances, electrical work, and similar items. Locate openings accurately and use templates or roughing-in diagrams to produce accurately sized and shaped openings. Sand edges of cutouts to remove splinters and burrs.

2.6 SHOP FINISHING

- A. General: Finish architectural cabinets at manufacturer's shop as specified in this Section. Defer only final touchup, cleaning, and polishing until after installation.
- B. General: Shop finish transparent-finished architectural cabinets at manufacturer's shop as specified in this Section. See Section 099123 "Interior Painting" for field finishing of opaque-finished architectural cabinets.
- C. General: Drawings indicate items that are required to be shop finished. Finish these items at manufacturer's shop as specified in this Section. See Section 099300 "Staining and Transparent Finishing" for field finishing of architectural cabinets.

- D. Preparation for Finishing: Comply with referenced quality standard for sanding, filling countersunk fasteners, sealing concealed surfaces, and similar preparations for finishing architectural cabinets, as applicable to each unit of work.
1. Backpriming: Apply one coat of sealer or primer, compatible with finish coats, to concealed surfaces of cabinets.
- E. Finish for Transparent and Opaque Stains:
1. Architectural Woodwork Standards Grade: Premium.
 2. Finish: System - 11, catalyzed polyurethane, or 12, water-based polyurethane.
 3. Wash Coat for Closed-Grain Woods: Apply wash-coat sealer to cabinets made from closed-grain wood before staining and finishing.
 4. Staining: Match approved samples for color.
 5. Sheen: Satin, 31-45 gloss units measured on 60-degree gloss meter per ASTM D523.

PART 3 - EXECUTION

3.1 INSTALLATION

- A. Before installation, condition cabinets to humidity conditions in installation areas for not less than 72 hours.
- B. Architectural Woodwork Standards Grade: Install cabinets to comply with quality standard grade of item to be installed.
- C. Anchor cabinets to anchors or blocking built in or directly attached to substrates. Secure with countersunk, concealed fasteners and blind nailing. Use fine finishing nails for exposed fastening, countersunk and filled flush with cabinet surface.
1. For shop-finished items, use filler matching finish of items being installed.
- D. Install cabinets level, plumb, and true in line to a tolerance of 1/8 inch in 96 inches (3 mm in 2400 mm) using concealed shims.
1. Scribe and cut cabinets to fit adjoining work, refinish cut surfaces, and repair damaged finish at cuts.
 2. Install cabinets without distortion so doors and drawers fit openings and are accurately aligned. Adjust hardware to center doors and drawers in openings and to provide unencumbered operation. Complete installation of hardware and accessory items as indicated.
 3. Maintain veneer sequence matching of cabinets with transparent finish.
 4. Fasten wall cabinets through back, near top and bottom, and at ends not more than 16 inches (400 mm) o.c. with No. 10 wafer-head screws sized for not less than 1-1/2-inch (38-mm) penetration into wood framing, blocking, or hanging strips.
- E. Shop Finishes: Touch up finishing after installation of architectural cabinets. Fill nail holes with matching filler.

3.2 FIELD QUALITY CONTROL

- A. Inspections: Provide inspection of installed Work through AWI's Quality Certification Program certifying that woodwork, including installation, complies with requirements of the Architectural Woodwork Standards for the specified grade.
 - 1. Inspection entity shall prepare and submit report of inspection.

END OF SECTION 064113

SECTION 064116 - PLASTIC-LAMINATE-CLAD ARCHITECTURAL CABINETS

PART 1 - GENERAL

1.1 SUMMARY

A. Section Includes:

1. Plastic-laminate-clad architectural cabinets.
2. Wood furring, blocking, shims, and hanging strips for installing plastic-laminate-clad architectural cabinets that are not concealed within other construction.

1.2 ACTION SUBMITTALS

A. Product Data: For each type of product.

1. Include data for fire-retardant treatment from chemical-treatment manufacturer and certification by treating plant that treated materials comply with requirements.

B. Shop Drawings:

1. Include plans, elevations, sections, and attachment details.
2. Apply AWI Quality Certification Program label to Shop Drawings.

C. Samples: For each exposed product and for each color and texture specified.

1.3 INFORMATIONAL SUBMITTALS

A. Qualification Data: For manufacturer and Installer.

1.4 CLOSEOUT SUBMITTALS

A. Quality Standard Compliance Certificates: AWI Quality Certification Program certificates.

1.5 QUALITY ASSURANCE

A. Manufacturer's Qualifications: Employs skilled workers who custom fabricate products similar to those required for this Project and whose products have a record of successful in-service performance.

1. Manufacturer's Certification: Licensed participant in AWI's Quality Certification Program.

B. Installer Qualifications: Licensed participant in AWI's Quality Certification Program.

PART 2 - PRODUCTS

2.1 PLASTIC-LAMINATE-CLAD ARCHITECTURAL CABINETS

- A. Quality Standard: Unless otherwise indicated, comply with the Architectural Woodwork Standards for grades of cabinets indicated for construction, finishes, installation, and other requirements.
- B. Architectural Woodwork Standards Grade: Premium.
- C. Type of Construction: Frameless.
- D. Door and Drawer-Front Style: Flush overlay.
- E. Laminate Cladding for Exposed Surfaces:
 - 1. Horizontal Surfaces: Grade HGL.
 - 2. Postformed Surfaces: Grade HGP.
 - 3. Vertical Surfaces: Grade VGS.
 - 4. Edges: Grade VGS.
 - 5. Pattern Direction: Vertically for drawer fronts, doors, and fixed panels.
- F. Concealed Backs of Panels with Exposed Plastic-Laminate Surfaces: High-pressure decorative laminate, NEMA LD 3, Grade BKL.
- G. Drawer Construction: Fabricate with exposed fronts fastened to subfront with mounting screws from interior of body.
 - 1. Join subfronts, backs, and sides with glued rabbeted joints supplemented by mechanical fasteners or glued dovetail joints.
- H. Colors, Patterns, and Finishes: Provide materials and products that result in colors and textures of exposed laminate surfaces complying with the following requirements:
 - 1. As indicated by laminate manufacturer's designations. Refer to Interior Finish Schedule, Drawing Sheet F1.1.

2.2 WOOD MATERIALS

- A. Wood Products: Provide materials that comply with requirements of referenced quality standard for each type of architectural cabinet and quality grade specified unless otherwise indicated.
 - 1. Wood Moisture Content: 5 to 10 percent.
- B. Composite Wood and Agrifiber Products: Provide materials that comply with requirements of referenced quality standard for each type of architectural cabinet and quality grade specified unless otherwise indicated.

1. Particleboard: ANSI A208.1, Grade M-2-Exterior Glue.
2. Softwood Plywood: DOC PS 1, medium-density overlay.
3. Thermoset Decorative Panels: Particleboard or MDF finished with thermally fused, melamine-impregnated decorative paper and complying with requirements of NEMA LD 3, Grade VGL, for Test Methods 3.3, 3.4, 3.6, 3.8, and 3.10.

2.3 CABINET HARDWARE AND ACCESSORIES

- A. General: Provide cabinet hardware and accessory materials associated with architectural cabinets except for items specified in Section 087100 "Door Hardware." Refer to Casework Hardware Specs, Sheet A720 for specific products required.
- B. Frameless Concealed Hinges (European Type): BHMA A156.9, B01602, 110 degrees of opening, self-closing.
- C. Back-Mounted Tab Pulls: BHMA A156.9, B02011.
- D. Wire Bar Pulls: Back mounted, solid metal, 5/16 inch (8 mm) in diameter, length varies, refer to Interior Elevations and Interior Details on drawings..
- E. Catches: Push-in magnetic catches, BHMA A156.9, B03131.
- F. Adjustable Shelf Standards and Supports: BHMA A156.9, B04071; with shelf rests, B04081.
- G. Shelf Rests: BHMA A156.9, B04013; metal.
- H. Drawer Slides: BHMA A156.9.
 1. Grade 1: Side mounted.
 - a. Type: Full extension.
 - b. Material: Zinc-plated steel with polymer rollers.
 2. Grade 1HD-100: Side mounted; full-extension type; zinc-plated-steel ball-bearing slides.
 3. For drawers not more than 3 inches (75 mm) high and not more than 24 inches (600 mm) wide, provide Grade 1.
 4. For drawers more than 3 inches (75 mm) high, but not more than 6 inches (150 mm) high and not more than 24 inches (600 mm) wide, provide Grade 1.
 5. For drawers more than 6 inches (150 mm) high or more than 24 inches (600 mm) wide, provide Grade 1HD-100.
 6. For trash bins not more than 20 inches (500 mm) high and 16 inches (400 mm) wide, provide Grade 1HD-100.
- I. Door Locks: BHMA A156.11, E07121.
- J. Drawer Locks: BHMA A156.11, E07041.
- K. Door and Drawer Silencers: BHMA A156.16, L03011.

- L. Grommets for Cable Passage: 2-inch (51-mm) OD, molded-plastic grommets and matching plastic caps with slot for wire passage.
 - 1. Color: White.
- M. Exposed Hardware Finishes: For exposed hardware, provide finish that complies with BHMA A156.18 for BHMA finish number indicated.
 - 1. Satin Nickel (US15) and Flat Black (US19): BHMA 626 for brass or bronze base; BHMA 652 for steel base.
 - 2. Black Onyx.
- N. For concealed hardware, provide manufacturer's standard finish that complies with product class requirements in BHMA A156.9.

2.4 MISCELLANEOUS MATERIALS

- A. Furring, Blocking, Shims, and Hanging Strips: Fire-retardant-treated softwood lumber, kiln-dried to less than 15 percent moisture content.
- B. Anchors: Select material, type, size, and finish required for each substrate for secure anchorage. Provide metal expansion sleeves or expansion bolts for post-installed anchors. Use nonferrous-metal or hot-dip galvanized anchors and inserts at inside face of exterior walls and at floors.
- C. Adhesive for Bonding Plastic Laminate: Unpigmented contact cement.
 - 1. Adhesive for Bonding Edges: Hot-melt adhesive or adhesive specified above for faces.

2.5 FABRICATION

- A. Complete fabrication, including assembly and hardware application, to maximum extent possible before shipment to Project site. Disassemble components only as necessary for shipment and installation. Where necessary for fitting at site, provide ample allowance for scribing, trimming, and fitting.
- B. Shop-cut openings to maximum extent possible to receive hardware, appliances, electrical work, and similar items. Locate openings accurately and use templates or roughing-in diagrams to produce accurately sized and shaped openings. Sand edges of cutouts to remove splinters and burrs.

PART 3 - EXECUTION

3.1 INSTALLATION

- A. Before installation, condition cabinets to humidity conditions in installation areas for not less than 72 hours.

- B. Architectural Woodwork Standards Grade: Install cabinets to comply with quality standard grade of item to be installed.
- C. Anchor cabinets to anchors or blocking built in or directly attached to substrates. Secure with wafer-head cabinet installation screws.
- D. Install cabinets level, plumb, and true in line to a tolerance of 1/8 inch in 96 inches (3 mm in 2400 mm) using concealed shims.
 - 1. Scribe and cut cabinets to fit adjoining work, refinish cut surfaces, and repair damaged finish at cuts.
 - 2. Install cabinets without distortion so doors and drawers fit openings and are accurately aligned. Adjust hardware to center doors and drawers in openings and to provide unencumbered operation. Complete installation of hardware and accessory items as indicated.
 - 3. Fasten wall cabinets through back, near top and bottom, and at ends not more than 16 inches (400 mm) o.c. with No. 10 wafer-head screws sized for not less than 1-1/2-inch (38-mm) penetration into wood framing, blocking, or hanging strips or No. 10 wafer-head sheet metal screws through metal backing or metal framing behind wall finish.

3.2 FIELD QUALITY CONTROL

- A. Inspections: Provide inspection of installed Work through AWI's Quality Certification Program certifying that woodwork, including installation, complies with requirements of the Architectural Woodwork Standards for the specified grade.
 - 1. Inspection entity shall prepare and submit report of inspection.

END OF SECTION 064116

THIS PAGE INTENSIONALLY LEFT BLANK

SECTION 071113 - BITUMINOUS DAMPPROOFING

PART 1 - GENERAL

1.1 SUMMARY

- A. Section includes cold-applied, emulsified-asphalt dampproofing.

1.2 SUBMITTALS

- A. Product Data: For each type of product.

1.3 PROJECT CONDITIONS

- A. Ventilation: Provide adequate ventilation during application of dampproofing in enclosed spaces and confined areas such as foundation trenches. Maintain ventilation until dampproofing has cured.

PART 2 - PRODUCTS

2.1 MATERIALS, GENERAL

- A. VOC Content: Products shall comply with VOC content limits of authorities having jurisdiction unless otherwise required.

2.2 COLD-APPLIED, EMULSIFIED-ASPHALT DAMPPROOFING

- A. Manufacturers: Subject to compliance with requirements, provide products by one of the following:

1. BASF Construction Chemicals - Building Systems; Sonneborn Brand Products.
2. ChemMasters, Inc.
3. Euclid Chemical Company (The); an RPM company.
4. Henry Company.
5. Meadows, W. R., Inc.

- B. Trowel Coats: ASTM D 1227, Type II, Class 1.
- C. Fibered Brush and Spray Coats: ASTM D 1227, Type II, Class 1.
- D. Brush and Spray Coats: ASTM D 1227, Type III, Class 1.
- E. VOC Content: 30 g/L or less.

2.3 AUXILIARY MATERIALS

- A. General: Furnish auxiliary materials recommended in writing by dampproofing manufacturer for intended use and compatible with bituminous dampproofing.
- B. Emulsified-Asphalt Primer: ASTM D 1227, Type III, Class 1, except diluted with water as recommended in writing by manufacturer.
- C. Asphalt-Coated Glass Fabric: ASTM D 1668, Type I.

PART 3 - EXECUTION

3.1 APPLICATION, GENERAL

- A. Comply with manufacturer's written instructions for substrate preparation, dampproofing application, cure time between coats, and drying time before backfilling unless more stringent requirements are indicated.
 - 1. Apply dampproofing to provide continuous plane of protection to below-grade, foundation walls where habitable space is not on the interior side of such walls. Apply to footings and exterior stair and ramp foundation walls and footings.
 - 2. Apply additional coats if recommended in writing by manufacturer or to achieve a smooth surface and uninterrupted coverage.
- B. Where dampproofing footings and foundation walls, apply from finished-grade line to top of footing; extend over top of footing and down a minimum of 6 inches (150 mm) over outside face of footing.
 - 1. Extend dampproofing 12 inches (300 mm) onto intersecting walls and footings, but do not extend onto surfaces exposed to view when Project is completed.
 - 2. Install flashings and corner protection stripping at internal and external corners, changes in plane, construction joints, cracks, and where shown as "reinforced," by embedding an 8-inch- (200-mm-) wide strip of asphalt-coated glass fabric in a heavy coat of dampproofing. Dampproofing coat for embedding fabric is in addition to other coats required.

3.2 COLD-APPLIED, EMULSIFIED-ASPHALT DAMPPROOFING

- A. Concrete Foundations and Parged Masonry Foundation Walls: Apply two brush or spray coats at not less than 1.5 gal./100 sq. ft. (0.6 L/sq. m) for first coat and 1 gal./100 sq. ft. (0.4 L/sq. m) for second coat, one fibered brush or spray coat at not less than 3 gal./100 sq. ft. (1.2 L/sq. m), or one trowel coat at not less than 4 gal./100 sq. ft. (1.6 L/sq. m).
- B. Unparged Masonry Foundation Walls: Apply primer and two brush or spray coats at not less than 1.5 gal./100 sq. ft. (0.6 L/sq. m) for first coat and 1 gal./100 sq. ft. (0.4 L/sq. m) for second coat, primer and one fibered brush or spray coat at not less than 3 gal./100 sq. ft. (1.2 L/sq. m), or primer and one trowel coat at not less than 5 gal./100 sq. ft. (2 L/sq. m).

END OF SECTION 071113

THIS PAGE LEFT INTENSIONALLY BLANK

SECTION 071326 - SELF-ADHERING SHEET WATERPROOFING

PART 1 - GENERAL

1.1 SUMMARY

A. Section Includes:

1. Post-applied, self-adhered sheet waterproofing and primer.

1.2 PREINSTALLATION MEETINGS

- A. Preinstallation Conference: Conduct conference at Project site.

1.3 ACTION SUBMITTALS

- A. Product Data: For each type of product.

- B. Shop Drawings: Show locations and extent of waterproofing and details of substrate joints and cracks, expansion joints, sheet flashings, penetrations, inside and outside corners, tie-ins with adjoining waterproofing, and other termination conditions.

1. Include setting drawings showing layout, sizes, sections, profiles, and joint details of pedestal-supported concrete pavers.

1.4 INFORMATIONAL SUBMITTALS

- A. Sample warranties.

1.5 QUALITY ASSURANCE

- A. Installer Qualifications: An entity that employs installers and supervisors who are trained and approved by waterproofing manufacturer.

1.6 WARRANTY

- A. Manufacturer's Warranty: Manufacturer agrees to furnish replacement waterproofing material for waterproofing that does not comply with requirements or that fails to remain watertight within specified warranty period.

1. Warranty Period: Five years from date of Substantial Completion.

PART 2 - PRODUCTS

2.1 MANUFACTURER

- A. Subject to compliance with performance requirements, provide products by the following manufacturer or approved equivalent:
1. GCP Applied Technologies, Cambridge, MA, 877-423-6491, www.gcpat.com, PREPRUFE 800PA or PREPRUFE 800PA Low Temperature.

2.2 POST-APPLIED SHEET WATERPROOFING

- A. Post-Applied Sheet Waterproofing: Minimum 30-mil (0.8-mm) nominal thickness, self-adhering sheet consisting of high preforming HDPE film and fully synthetic, non-asphaltic adhesive formulated for application with primer that complies with VOC limits of authorities having jurisdiction.
1. Physical Properties:
 - a. Roll Dimension: 4 feet (1.2 m) wide.
 - b. Roll Weight: 77 lbs. (35 kg) gross.
 - c. Color: White
 - d. Tensile Strength, Membrane: 1000 psi (8274 kPa) minimum; ASTM D412, Die C, modified.
 - e. Low-Temperature Flexibility: Pass at minus 25 deg F (minus 32 deg C); ASTM D1970/D1970M.
 - f. Crack Cycling: Unaffected after 100 cycles of movement at minus 25 deg F (minus 32 deg C); ASTM C836/C836M.
 - g. Puncture Resistance: 100 lbf (467 N) minimum; ASTM E154/E154M.
 - h. Water Absorption: 0.1 percent weight-gain maximum after 48-hour immersion at 70 deg F (21 deg C); ASTM D570.
 - i. Water Vapor Permeance: 0.1 perm maximum; ASTM E96/E96M, Water Method.
 - j. Hydrostatic-Head Resistance: Less than 231 feet (71 m) of water; ASTM D5385.
 2. Sheet Strips: Double sided, self-adhering, detail tape of same material and thickness as sheet waterproofing.

2.3 AUXILIARY MATERIALS

- A. Furnish auxiliary materials recommended by waterproofing manufacturer for intended use and compatible with sheet waterproofing.
1. Furnish liquid-type auxiliary materials that comply with VOC limits of authorities having jurisdiction.
- B. Primer: Liquid primer recommended by sheet waterproofing manufacturer for Insulated Concrete Forming substrate.

- C. Metal Termination Bars: Aluminum bars, approximately 1 by 1/8 inch (25 by 3 mm), predrilled at 9-inch (229-mm) centers

2.4 MOLDED-SHEET DRAINAGE PANELS

- A. Nonwoven-Geotextile-Faced, Molded-Sheet Drainage Panel without Polymeric Film: Composite subsurface drainage panel acceptable to waterproofing manufacturer and consisting of a studded, nonbiodegradable, molded-plastic-sheet drainage core; with a nonwoven, needle-punched geotextile facing with an apparent opening size not exceeding No. 70 (0.21-mm) sieve laminated to one side of the core, without a polymeric film bonded to the other side; and with a vertical flow rate through the core of 9 to 21 gpm per ft. (112 to 261 L/min. per m).

PART 3 - EXECUTION

3.1 PREPARATION

- A. Clean, prepare, and treat substrates according to manufacturer's written instructions. Provide clean, dust-free, and dry substrates for waterproofing application.
- B. Mask off adjoining surfaces not receiving waterproofing to prevent spillage and overspray affecting other construction.

3.2 INSTALLATION OF SHEET-WATERPROOFING

- A. Install self-adhering sheets according to waterproofing manufacturer's written instructions.
- B. Apply primer to substrates at required rate and allow it to dry. Limit priming to areas that will be covered by sheet waterproofing in same day. Reprime areas exposed for more than 24 hours.
- C. Apply and firmly adhere sheets over area to receive waterproofing. Accurately align sheets and maintain uniform 2-1/2-inch- (64-mm-) minimum lap widths and end laps. Overlap and seal seams, and stagger end laps to ensure watertight installation.
 - 1. When ambient and substrate temperatures range between 25 and 40 deg F (minus 4 and plus 5 deg C), install self-adhering, modified bituminous sheets produced for low-temperature application. Do not use low-temperature sheets if ambient or substrate temperature is higher than 60 deg F (16 deg C).
- D. Install sheet-waterproofing and auxiliary materials to tie into adjacent waterproofing and air barrier.
- E. Repair tears, voids, and lapped seams in waterproofing not complying with requirements. Slit and flatten fishmouths and blisters. Patch with sheet waterproofing extending 6 inches (150 mm) beyond repaired areas in all directions.

- F. Immediately install molded-sheet drainage panels course with butted joints over waterproofing membrane.

3.3 INSTALLATION OF MOLDED-SHEET DRAINAGE-PANELS

- A. Place and secure molded-sheet drainage panels, with geotextile facing away from wall or deck substrate, according to manufacturer's written instructions. Use detail tape method that does not penetrate waterproofing. Lap edges and ends of geotextile to maintain continuity. Protect installed molded-sheet drainage panels during subsequent construction.

3.4 PROTECTION, REPAIR, AND CLEANING

- A. Protect installed insulation drainage panels from damage due to UV light, harmful weather exposures, physical abuse, and other causes. Provide temporary coverings where insulation is subject to abuse and cannot be concealed and protected by permanent construction immediately after installation.
- B. Correct deficiencies in or remove waterproofing that does not comply with requirements; repair substrates, reapply waterproofing, and repair sheet flashings.
- C. Clean spillage and soiling from adjacent construction using cleaning agents and procedures recommended in writing by manufacturer of affected construction.

END OF SECTION 071326

SECTION 072100 - THERMAL INSULATION

PART 1 - GENERAL

1.1 SUMMARY

A. Section Includes:

1. Extruded polystyrene foam-plastic board insulation.
2. Mineral-wool sound attenuation blanket insulation.
3. Loose-fill insulation.

1.2 ACTION SUBMITTALS

- A. Product Data: For each type of product.

1.3 DELIVERY, STORAGE AND HANDLING

- A. Deliver and store thermal insulation materials in manufacturer's unopened containers or bundles, fully identified by name, brand, type and grade. Exercise care to avoid damage during unloading, storing and installation. Keep materials free of dirt and other foreign matter.

1.4 PROJECT CONDITIONS

- A. Environmental Requirements: Install thermal insulation only when weather conditions will permit work to be performed in accordance with manufacturer's recommendations and warranty requirements.

PART 2 - PRODUCTS

2.1 EXTRUDED POLYSTYRENE FOAM-PLASTIC BOARD

- A. Extruded polystyrene boards in this article are also called "XPS boards."
- B. Extruded-Polystyrene Board Insulation: ASTM C 578, with maximum flame-spread and smoke-developed indexes of 75 and 450, respectively, per ASTM E 84.
1. Manufacturers: Subject to compliance with requirements, provide products by one of the following:
 - a. Dupont (formally The Dow Chemical Company) – Basis-of-Design.
 - b. Owens Corning.
 - c. Pactiv Building Products.

2. Type IV: 25 psi (173 kPa), Square Edge, 2 inches thick, 3/4 inch thick, and thicknesses as indicated on drawings by Dupont or approved equivalent. Fire Propagation Characteristics: Passes NFPA 285 testing as part of an approved assembly.
3. Type VI for use on below grade horizontal applications: 40 psi (276 kPa), Highload 40, 2 inch thick by Dupont or approved equivalent.

2.2 SOUND ATTENUATION FIRE BLANKET (SAFB) MINERAL-WOOL INSULATION

- A. Manufacturers: Subject to compliance with requirements, provide the following product:
 1. Thermafiber, An Owens Corning Company, SAFB, 4 pcf nominal (Basis of Design).
 2. Rockwool International.
 3. Johns Manville.
- B. Unfaced, Mineral-Wool Insulation: ASTM C 665, Type I (blankets without membrane facing) and ASTM C553; consisting of fibers; with maximum flame-spread and smoke-developed indexes of 25 and 50, respectively, per ASTM E 84; passing ASTM E 136 for combustion characteristics. Provide identification of mark indicating R-value of each piece of insulation 12 inches (305 mm) and wider in width.

2.3 ACCESSORIES

- A. Insulation for Miscellaneous Voids:
 1. Spray Polyurethane Foam Insulation: ASTM C 1029, Type II, closed cell, with maximum flame-spread and smoke-developed indexes of 75 and 450, respectively, per ASTM E 84.
- B. Adhesive for Bonding Insulation: Product compatible with insulation and air and water barrier materials, and with demonstrated capability to bond insulation securely to substrates without damaging insulation and substrates.

PART 3 - EXECUTION

3.1 INSTALLATION, GENERAL

- A. Comply with insulation manufacturer's written instructions applicable to products and applications.
- B. Install insulation that is undamaged, dry, and unsoiled and that has not been left exposed to ice, rain, or snow at any time.
- C. Install insulation with manufacturer's R-value label exposed after insulation is installed.
- D. Extend insulation to envelop entire area to be insulated. Fit tightly around obstructions and fill voids with insulation. Remove projections that interfere with placement.

- E. Provide sizes to fit applications and selected from manufacturer's standard thicknesses, widths, and lengths. Apply single layer of insulation units unless multiple layers are otherwise shown or required to make up total thickness or to achieve R-value.

3.2 INSTALLATION OF BELOW-GRADE INSULATION

- A. On vertical surfaces, set XPS Board insulation units using manufacturer's recommended adhesive according to manufacturer's written instructions.
 - 1. If not otherwise indicated, extend Type IV, 25 psi insulation a minimum of 24 inches (610 mm) below exterior grade line.
- B. On horizontal surfaces, loosely lay XPS Board insulation according to manufacturer's written instructions. Stagger end joints and tightly abut insulation units.
 - 1. If not otherwise indicated, extend Type VI, 40 psi insulation a minimum of 24 inches (610 mm) in from exterior walls.

3.3 INSTALLATION OF SAFB INSULATION IN INTERIOR CONSTRUCTION

- A. Mineral-Wool Sound Attenuation Fire Blankets: Install between framing members of interior partitions and above finished ceilings where acoustic insulation is indicated for sound attenuation batts.
 - 1. Use insulation widths and lengths that fill the cavities formed by framing members. If more than one length is required to fill the cavities, provide lengths that will produce a snug fit between ends.
 - 2. Place insulation in cavities formed by framing members to produce a friction fit between edges of insulation and adjoining framing members.
 - 3. Maintain 3-inch (76-mm) clearance of insulation around recessed lighting fixtures not rated for or protected from contact with insulation.

3.4 INSTALLATION OF INSULATION AT VOIDS

- A. Miscellaneous Voids: Install insulation in miscellaneous voids and cavity spaces where required or indicated to prevent gaps in thermal insulation, acoustic insulation and provide air-tight condition using the following materials:
 - 1. SAFB Mineral-Wool Insulation: Install at all acoustic insulation gaps and where safin insulation is indicated.
 - 2. Spray Polyurethane Insulation: Apply according to manufacturer's written instructions to provide air-tight condition at Shooting Range.

3.5 PROTECTION

- A. Protect installed insulation from damage due to harmful weather exposures, physical abuse, and other causes. Provide temporary coverings or enclosures where insulation is subject to abuse and cannot be concealed and protected by permanent construction immediately after installation.

END OF SECTION 072100

THIS PAGE INTENTIONALLY LEFT BLANK

SECTION 072413 - POLYMER-BASED EXTERIOR INSULATION AND FINISH SYSTEM (EIFS)

PART 1 - GENERAL

1.1 SUMMARY

A. Section Includes:

1. EIFS-clad barrier-wall assemblies that are field applied vertical above grade exterior ICF wall surfaces.

1.2 PREINSTALLATION MEETINGS

- A. Preinstallation Conference: Conduct conference at Project site.

1.3 ACTION SUBMITTALS

- A. Product Data: For each EIFS component, trim, and accessory.
- B. Samples: For each exposed product and for each color and texture specified.

1.4 INFORMATIONAL SUBMITTALS

- A. Manufacturer certificates.
- B. Product certificates.
- C. Product test reports.
- D. Sample warranty.

1.5 CLOSEOUT SUBMITTALS

- A. Maintenance data.

1.6 QUALITY ASSURANCE

- A. Manufacturer's Qualifications: The textured finish system manufacturer shall be a company with at least thirty five years of experience in manufacturing specialty finishes and regularly engaged in the manufacture and marketing of products specified herein. The manufacturer shall have an ISO 9001:2008 certified quality system and ISO 14001:2004 certified environmental management system.

- B. Installer's Qualifications: The contractor shall be qualified to perform the work specified by reason of experience. Contractor shall have at least 5 years of experience in commercial textured finish application, and shall have completed at least 3 projects of similar size and complexity. Contractor shall provide proof before commencement of work that he/she will maintain and supervise a qualified crew of applicators through the duration of the work. When requested Contractor shall provide a list of the last three comparable jobs including the name, location, and start and finish dates for the work.
- C. Mock-ups: The contractor shall install a mock-up of the system for evaluation and approval by Architect and building owner.

1.7 DELIVERY, STORAGE, AND HANDLING

- A. Deliver products in original packaging, labeled with product identification, manufacturer, and batch number.
- B. Store products in a dry area with temperature maintained between 50 and 85 degrees F (10 and 29 degrees C). Protect from direct sunlight. Protect from freezing. Protect from extreme heat (>90 degrees F [32 degrees C]).
- C. Handle products in accordance with manufacturer's printed instructions.

1.8 WARRANTY

- A. Manufacturer's Special Warranty: Manufacturer agrees to repair or replace components of EIFS that fail in materials or workmanship within specified warranty period.
 - 1. Warranty Period: Five years from date of Substantial Completion.

PART 2 - PRODUCTS

2.1 MANUFACTURERS

- A. Subject to compliance with performance requirements, provide products by the following manufacturer or approved equivalent:
 - 1. Sto Corporation, Atlanta, GA, 404-346-3666, www.stocorp.com, Acrylic Plaster Finish.

2.2 PERFORMANCE REQUIREMENTS

- A. EIFS Performance: Comply with ASTM E2568 and with the following:
 - 1. Weathertightness: Resistant to water penetration from exterior.
 - 2. Impact Performance: ASTM E2568, High impact resistance.

2.3 EIFS MATERIALS

A. Textured Finish:

1. Stolit – high performance decorative and protective acrylic-based textured wall finish with integral color, complies with SCAQMD Rule 1113 for architectural finishes.

B. Primer:

1. Sto Primer – acrylic-based sanded primer, complies with SCAQMD Rule 1113 for primers.

C. Waterproof Base Coat:

1. Sto Flexyl – one component acrylic-based additive combined with portland cement, complies with SCAQMD Rule 1113 for waterproofing sealers.

D. Base Coat:

1. Sto BTS Plus – one component polymer modified portland cement high build base coat..

E. Mesh:

1. First layer mesh of Sto Armor Mat.
2. Sto Mesh – nominal 4.5 oz/sq.yd. (153 g/sq.m.) glass fiber reinforcing mesh treated for compatibility with Sto materials.

PART 3 - EXECUTION

3.1 EIFS INSTALLATION

- A. Comply with ASTM C1397, ASTM E2511, and EIFS manufacturer's written instructions for installation of EIFS as applicable to each type of substrate.
- B. Flexible-Membrane Flashing: Apply and lap to shed water; seal at openings, penetrations, and terminations. Prime substrates with flashing primer if required and install flashing.
- C. Rasp the entire ICF wall surface to remove any UV degradation on the surface, to make abutting joints flush, and to minimize any planar irregularities in the surface. Ensure form ties are not exposed on the ICF surface.
- D. Water-Resistant Base Coat: Apply full-thickness coverage to exposed insulation. Immediately trowel in Sto Armor Mat and allow 24 hours to cure.
- E. Install nominal 1/8 inch (3 mm) base coat by trowel to the wall surface. Work horizontally or vertically in strips of 40 inches (1016 mm), and immediately embed the mesh into the wet base coat by troweling from the center to the edges of the mesh. Overlap mesh not less than 2-1/2 inches (64 mm) at mesh seams and feather at seams. Double wrap all inside and outside corners

with minimum 8-inch (203 mm) overlap in each direction. Apply strip-reinforcing mesh around openings, extending 4 inches (100 mm) beyond perimeter. Apply additional 9-by-12-inch (230-by-300-mm) strip-reinforcing mesh diagonally at corners of openings (re-entrant corners). Avoid wrinkles in the mesh. The mesh must be fully embedded so that no mesh color shows through. Re-skim with additional base coat if mesh color is visible.

- F. When the base coat application is dry apply the primer by brush or roller to the entire base coat surface.
- G. Finish Coat: Apply full-thickness coverage over dry primed base coat, maintaining a wet edge at all times for uniform appearance, to produce a uniform finish of color and texture matching approved sample and free of cold joints, shadow lines, and texture variations.
- H. Protection:
 - 1. Provide protection of installed materials from water infiltration into or behind them during and after construction.
 - 2. Provide protection of installed materials from dust, dirt, precipitation, freezing and continuous high humidity until they are fully dry

END OF SECTION 072413

SECTION 072600 - VAPOR RETARDERS

PART 1 - GENERAL

1.1 SUMMARY

A. Section Includes:

1. Multi-Layer Polyolefin Resin vapor retarder for under slab.
2. Polyimide film vapor retarder for below roof.

B. Related Requirements:

1. Section 033000 "Cast-in-Place Concrete" for under-slab vapor retarders.
2. Section 072100 "Thermal Insulation" for rigid foundation insulation.

1.2 ACTION SUBMITTALS

A. Product Data: For each type of product.

1.3 INFORMATIONAL SUBMITTALS

A. Product test reports.

PART 2 - PRODUCTS

2.1 MULTI-LAYER POLYOLEFIN RESIN VAPOR RETARDER

A. Multi-Layer Polyolefin Resin Vapor Retarders: Multi-layer plastic extrusion manufactured with Prime, virgin, polyolefin resins and thickness of not less than 15 mils, with a water vapor permeance of 0.0086 perms when tested in accordance with ASTM F1249 and a maximum permeance after conditioning of 0.0098 perms when tested in accordance with ASTM E154 Section 8, F1249. Under slab vapor retarder shall exceed Class A, B & C.

1. Manufacturers: Subject to compliance with requirements, provide products by one of the following:
 - a. GCP Applied Technologies, Florprufe 120 integrally bonded vapor protection.
 - b. Stego Industries, LLC, Stego Wrap Vapor Barrier.
 - c. Raven Industries, Inc., Raven Engineered Films, VaporBlock Plus 20
 - d. Reef Industries, Inc., Griffolyn Type 65 G.
 - e. ISI Building Products, Viper Vaporcheck II, 15 mil.

2. Accessories and Seam Tape: As recommended by manufacturer for sealing around penetrations.

2.2 POLYIMIDE FILM VAPOR RETARDER

- A. Sheet Retarder: Certaineed MemBrain, The SMART Vapor Retarder. Polyimide film vapor retarder for use with unfaced, vapor permeable glass fiber and mineral wool insulation in ceiling cavities. Material has a permeance of 1 perm or less when tested to ASTM E 86, dry cup method and increases to greater than 10 perms using the wet cup method.
 1. Water Vapor Permeance:
 - a. ASTM E 86, dry cup method: 1.0 perms (57ng/Pa*s*m2).
 - b. ASTM E 86, wet cup method: 10.0 perms (1144ng/Pa*s*m2).
 2. Fire Hazard Classification: ASTM E 84:
 - a. Maximum Flame Spread Index; 20.
 - b. Maximum Smoke Developed Index; 55.

PART 3 - EXECUTION

3.1 INSTALLATION OF VAPOR RETARDER UNDER SLAB

- A. Install vapor retarders over prepared grade and gravel bed in strict accordance with manufacturer's written requirements. Lap joints a minimum of 6 inches (150 mm) and seal with manufacturer's recommended tape.
- B. Extend vapor retarder over footings and seal to foundation wall or grade beam with manufacturer's recommended tape. Extend vapor retarder vertically minimum 16 inches (406 mm) above top of footing.
- C. Seal around penetrations such as utilities and columns in order to create a monolithic, airtight membrane at grade surface, perimeter, and all vertical penetrations using manufacturer's recommended tape and accessories.

3.2 INSTALLATION OF VAPOR RETARDER BELOW ROOF

- A. Install in accordance with manufacturer's instructions.
- B. Install in exterior spaces without gaps or voids. Do not compress insulation. Trim insulation neatly to fit spaces. Insulate miscellaneous gaps and voids.
- C. Fit insulation tight in spaces and tight to exterior side of mechanical and electrical services within plane of insulation.

- D. Install insulation with vapor barrier installed facing the warm side. Seal or tape joints as required.

END OF SECTION 072600

THIS PAGE INTENSIONALLY LEFT BLANK

SECTION 072726 - FLUID-APPLIED MEMBRANE AIR BARRIERS

PART 1 - GENERAL

1.1 SUMMARY

- A. Section includes fluid-applied, vapor-permeable membrane air and weather barrier.

1.2 PREINSTALLATION MEETINGS

- A. Preinstallation Conference: Conduct conference at Project site.

1.3 ACTION SUBMITTALS

- A. Product Data: For each type of product.
- B. Shop Drawings: For air-barrier assemblies.
 - 1. Include details for substrate joints and cracks, counterflashing strips, penetrations, inside and outside corners, terminations, and tie-ins with adjoining construction.

1.4 INFORMATIONAL SUBMITTALS

- A. Product certificates.
- B. Product test reports.

1.5 QUALITY ASSURANCE

- A. Installer Qualifications: An entity that employs installers and supervisors who are trained and approved by manufacturer.
- B. Mockups: Build mockup to set quality standards for materials and execution. Mock-up shall be approved by Architect and Owner prior to the ordering the required quantity of materials for the Work, and may not become part of the completed work.
 - 1. Build mockup of exterior wall assembly, incorporating, external stone veneer and siding, structural insulated wall panel, flashing, ties and typical penetrations, to demonstrate surface preparation, crack and joint treatment, application of air barriers, and sealing of gaps, terminations, and penetrations of air-barrier assembly. Refer to Section 044313.19 stone veneer and Section 074646 for siding.
 - 2. Approval of mockups does not constitute approval of deviations from the Contract Documents contained in mockups unless Architect specifically approves such deviations in writing.

3. Subject to compliance with requirements, approved mockups may become part of the completed Work if undisturbed at time of Substantial Completion.

PART 2 - PRODUCTS

2.1 MATERIALS, GENERAL

- A. VOC Content: 100 g/L or less when calculated according to 40 CFR 59, Subpart D (EPA Method 24) and complying with VOC content limits of authorities having jurisdiction.

2.2 PERFORMANCE REQUIREMENTS

- A. General: Air barrier shall be capable of performing as a continuous vapor-permeable air and water weather barrier and as a liquid-water drainage plane flashed to discharge to the exterior incidental condensation or water penetration. Air-barrier assemblies shall be capable of accommodating substrate movement and of sealing substrate expansion and control joints, construction material changes, penetrations, and transitions at perimeter conditions without deterioration and air leakage exceeding specified limits.

2.3 VAPOR-PERMEABLE MEMBRANE AIR-BARRIER

- A. Fluid-Applied, Vapor-Permeable Membrane Air Barrier: Elastomeric, water-based membrane.

1. Elastomeric, Water-Based Membrane:

- a. Henry Company, Air-Bloc 33MR, UV resistant Vapor Permeable Air and Weather Barrier Membrane or GCP Applied Technologies Inc., Perm-A-Barrier NPL 10 or approved equivalent by Carlisle Coatings and Waterproofing Inc.

2. Physical and Performance Properties:

- a. Air Permeance: Maximum 0.0016 cfm/sq. ft. of surface area at 1.57-lbf/sq. ft. (0.08 L/s x sq. m of surface area at 75-Pa) pressure difference; ASTM E 2178.
- b. Vapor Permeance: Minimum 11.6 perms (655 ng/Pa x s x sq. m); ASTM E 96/E 96M at 1/8 inch (3mm) wet film.
- c. Ultimate Elongation: Minimum 200 percent; ASTM D 412, Die C.
- d. Fire Propagation Characteristics: Passes NFPA 285 testing as part of an approved assembly.
- e. Flame Spread: 25; ASTM E84.
- f. Smoke Developed: 85; ASTM E84.

2.4 ACCESSORY MATERIALS

- A. General: Accessory materials recommended by air-barrier manufacturer to produce a complete air-barrier assembly and compatible with primary air-barrier material.

- B. Sprayed Polyurethane Foam Sealant: One- or two-component, foamed-in-place, polyurethane foam sealant, 1.5- to 2.0-lb/cu. ft (24- to 32-kg/cu. m) density; flame-spread index of 25 or less according to ASTM E 162; with primer and noncorrosive substrate cleaner recommended by foam sealant manufacturer.
- C. Termination Mastic: Air-barrier manufacturer's standard cold fluid-applied elastomeric liquid; trowel grade.

PART 3 - EXECUTION

3.1 SURFACE PREPARATION

- A. Mask off adjoining surfaces not covered by air barrier to prevent spillage and overspray affecting other construction.
- B. Remove fins, ridges, and other projections and fill holes, and other voids with substrate-patching membrane.
- C. At changes in substrate plane, apply sealant or termination mastic beads at sharp corners and edges to form a smooth transition from one plane to another.

3.2 INSTALLATION

- A. General: Install fluid-applied membrane air-barrier and accessory materials according to air-barrier manufacturer's written instructions to form a seal with adjacent construction and maintain a continuous air barrier.
 - 1. Coordinate the installation of air barrier with installation of roofing membrane and base flashing to ensure continuity of air barrier with roofing membrane.
 - 2. Install air-barrier assembly on roofing membrane or base flashing so that a minimum of 3 inches (75 mm) of coverage is achieved over each substrate.
- B. Apply primer to substrates at required rate and allow it to dry. Limit priming to areas that will be covered by fluid air-barrier material on same day. Reprime areas exposed for more than 24 hours.
 - 1. Prime glass-fiber-surfaced gypsum sheathing with number of prime coats needed to achieve required bond, with adequate drying time between coats.
- C. Connect and seal exterior wall air-barrier material continuously to roofing-membrane air barrier, concrete below-grade structures, floor-to-floor construction, exterior glazing and window systems, glazed curtain-wall systems, storefront systems, exterior louvers, exterior door framing, and other construction used in exterior wall openings, using accessory materials.
- D. At end of each working day, seal top edge of air barrier to substrate with termination mastic.

- E. Wall Openings: Prime concealed, perimeter frame surfaces of windows and doors. Apply transitions and flashing so that a minimum of 3 inches (75 mm) of coverage is achieved over each substrate. Maintain 3 inches (75 mm) of full contact over firm bearing to perimeter frames with not less than 1 inch (25 mm) of full contact. Fill gaps in perimeter frame surfaces of windows, curtain walls, storefronts, and doors, and miscellaneous penetrations of air-barrier material with foam sealant. Seal top of through-wall flashings to air barrier.
- F. Seal exposed edges of strips at seams, cuts, penetrations, and terminations not concealed by metal counterflashings or ending in reglets with termination mastic.
- G. Fluid-Applied Membrane Material: Apply a continuous unbroken air-barrier membrane to substrates according to the following thickness. Apply air-barrier membrane in full contact around protrusions such as masonry ties.
 - 1. Vapor-Permeable Membrane Air Barrier: Total dry film thickness as recommended in writing by manufacturer to meet performance requirements, but not less than 55-mil (1.3-mm) dry film thickness, applied in one or more equal coats.
- H. Do not cover air barrier until it has been tested and inspected by Owner's testing agency.
- I. Correct deficiencies in or remove air barrier that does not comply with requirements; repair substrates and reapply air-barrier components.

3.3 FIELD QUALITY CONTROL

- A. Testing Agency: Owner may engage a qualified testing agency to perform tests and inspections.
- B. Inspections: Air-barrier materials, accessories, and installation are subject to inspection for compliance with requirements.
- C. Tests: As determined by Owner's testing agency from among the following tests:
 - 1. Qualitative Air-Leakage Testing: Air-barrier assemblies will be tested for evidence of air leakage according to ASTM E 1186, smoke pencil with pressurization or depressurization or ASTM E 1186, chamber pressurization or depressurization with smoke tracers.
- D. Air barriers will be considered defective if they do not pass tests and inspections.
 - 1. Apply additional air-barrier material, according to manufacturer's written instructions, where inspection results indicate insufficient thickness.
 - 2. Remove and replace deficient air-barrier components for retesting as specified above.
- E. Repair damage to air barriers caused by testing; follow manufacturer's written instructions.
- F. Protect air-barrier system from damage during application and remainder of construction period, according to manufacturer's written instructions. Protect air barrier from contact with incompatible materials and sealants not approved by air-barrier manufacturer.
- G. Remove masking materials after installation.

END OF SECTION 072726

THIS PAGE INTENSIONALLY LEFT BLANK

SECTION 074113.16 - STANDING-SEAM METAL ROOF PANELS

PART 1 - GENERAL

1.1 SUMMARY

- A. Section includes standing-seam metal roof panels.
- B. Related Sections:
 - 1. Section 077253 "Snow Guards" for prefabricated devices designed to hold snow on the roof surface, allowing it to melt and drain off slowly.

1.2 PREINSTALLATION MEETINGS

- A. Preinstallation Conference: Conduct conference at Project site.

1.3 ACTION SUBMITTALS

- A. Product Data: For each type of product.
- B. Shop Drawings: Include fabrication and installation layouts of metal panels; details of edge conditions, joints, panel profiles, corners, anchorages, attachment system, trim, flashings, closures, and accessories; and special details.
- C. Samples: Submit sample board of metal panel colors for selection.
- D. Samples for Verification: For each exposed product and for color and texture specified.

1.4 INFORMATIONAL SUBMITTALS

- A. Product test reports.
- B. Warranties: Sample of special warranties.

1.5 CLOSEOUT SUBMITTALS

- A. Maintenance data.

1.6 QUALITY ASSURANCE

- A. Installer Qualifications: An entity that employs installers and supervisors who are trained and approved by manufacturer.

- B. UL-Certified, Portable Roll-Forming Equipment: UL-certified, portable roll-forming equipment capable of producing metal panels warranted by manufacturer to be the same as factory-formed products. Maintain UL certification of portable roll-forming equipment for duration of work.

1.7 DELIVERY, STORAGE, AND HANDLING

- A. Deliver components, metal panels, and other manufactured items so as not to be damaged or deformed. Package metal panels for protection during transportation and handling.
- B. Unload, store, and erect metal panels in a manner to prevent bending, warping, twisting, and surface damage.
- C. Stack metal panels horizontally on platforms or pallets, covered with suitable weathertight and ventilated covering. Store metal panels to ensure dryness, with positive slope for drainage of water. Do not store metal panels in contact with other materials that might cause staining, denting, or other surface damage.
- D. Retain strippable protective covering on metal panels during installation.

1.8 FIELD CONDITIONS

- A. Weather Limitations: Proceed with installation only when existing and forecasted weather conditions permit assembly of metal panels to be performed according to manufacturers' written instructions and warranty requirements.

1.9 COORDINATION

- A. Coordinate metal panel installation with rain drainage work, flashing, trim, construction of soffits, and other adjoining work to provide a leakproof, secure, and noncorrosive installation.

1.10 WARRANTY

- A. Special Warranty: Manufacturer's standard form in which manufacturer agrees to repair or replace components of metal panel systems that fail in materials or workmanship within specified warranty period.
 - 1. Warranty Period: Two years from date of Substantial Completion.
- B. Special Warranty on Panel Finishes: Manufacturer's standard form in which manufacturer agrees to repair finish or replace metal panels that show evidence of deterioration of factory-applied finishes within specified warranty period.
 - 1. Finish Warranty Period: 20 years from date of Substantial Completion.

- C. Special Weathertightness Warranty: Manufacturer's standard form in which manufacturer agrees to repair or replace standing-seam metal roof panel assemblies that fail to remain weathertight, including leaks, within specified warranty period.

1. Warranty Period: 20 years from date of Substantial Completion.

PART 2 - PRODUCTS

2.1 PERFORMANCE REQUIREMENTS

- A. Energy Performance: Provide roof panels according to the following when tested according to CRRC-1:
1. Three-year, aged Solar Reflectance Index of not less than 47 when calculated according to ASTM E 1980.
- B. Structural Performance: Provide metal panel systems capable of withstanding the effects of the following loads, based on testing according to ASTM E 1592:
1. Wind Loads: As indicated on Drawings.
 2. Other Design Loads: As indicated on Drawings.
 3. Deflection Limits: For wind loads, no greater than 1/240 of the span.
- C. Air Infiltration: Air leakage of not more than 0.05 cfm/sq. ft. when tested according to ASTM E 283 at the following test-pressure difference:
1. Test-Pressure Difference: 6.24 lbf/sq. ft. (300 Pa).
- D. Water Penetration under Static Pressure: No water penetration when tested according to ASTM E 331 for Tests A, B, and C at 5 gallons per hour water spray rate.
- E. Hydrostatic-Head Resistance: No water penetration when tested according to ASTM E 2140.
- F. Wind-Uplift Resistance: Provide metal roof panel assemblies that comply with UL 580 for wind-uplift-resistance class indicated.
1. Uplift Rating: UL 90.
- G. FM Global Listing: Provide metal roof panels and component materials that comply with requirements in FM Global 4471 as part of a panel roofing system and that are listed in FM Global's "Approval Guide" for Class 1 or noncombustible construction, as applicable. Identify materials with FM Global markings.
1. Fire/Windstorm Classification: Class 1A-105.
 2. Hail Resistance: MH.
- H. Thermal Movements: Allow for thermal movements from ambient and surface temperature changes by preventing buckling, opening of joints, overstressing of components, failure of joint

sealants, failure of connections, and other detrimental effects. Base calculations on surface temperatures of materials due to both solar heat gain and nighttime-sky heat loss.

1. Temperature Change (Range): 120 deg F (67 deg C), ambient; 180 deg F (100 deg C), material surfaces.

2.2 STANDING-SEAM METAL ROOF PANELS

- A. General: Provide factory-formed metal roof panels designed to be installed by lapping and interconnecting raised side edges of adjacent panels with joint type indicated and mechanically attaching panels to supports using concealed clips in side laps. Include clips, cleats, pressure plates, and accessories required for weathertight installation.

1. Aluminum Panel Systems: Unless more stringent requirements are indicated, comply with ASTM E 1637.

- B. Vertical-Rib, Seamed-Joint, Standing-Seam Metal Roof Panels: Formed with vertical ribs at panel edges and if required by manufacturer, intermediate stiffening ribs symmetrically spaced between ribs; designed for sequential installation by mechanically attaching panels to supports using concealed clips located under one side of panels, engaging opposite edge of adjacent panels, and mechanically seaming panels together.

1. Manufacturers: Subject to compliance with requirements, provide Basis of Design product or equivalent product by one of the following:

- a. AEP Span; A BlueScope Steel Company.
- b. ATAS International, Inc.
- c. Berridge Manufacturing Company, San Antonio, TX, www.berridge.com: Cee-Lock Panel with Extruded Vinyl Weatherseal (Basis of Design)
- d. Dimensional Metals, Inc.(DMI), www.dmimetals.com: 1-1/2" Snap-on-Seam.
- e. Merchant & Evans Inc., Burlington, NJ, www.ziprib.com: Zip-Rib.
- f. Petersen Aluminum Corporation.

2. Aluminum Sheet: Coil-coated sheet, ASTM B 209 (ASTM B 209M), alloy as standard with manufacturer, with temper as required to suit forming operations and structural performance required.

- a. Thickness: 0.032 inch (0.81 mm) or 0.040 inch (101 mm).
- b. Surface: Smooth, flat finish.
- c. Exterior Finish: Manufacturer's standard two-coat fluoropolymer.
- d. Color: As selected by Architect and Owner from manufacturer's range of colors meeting or exceeding minimum Solar Reflectance Index as listed herein.

3. Clips: Manufacturer's standard stainless steel, Cee-Lock clip to accommodate thermal movement and gable clip
4. Closure: Manufacturer's standard closed cell foam keyhole closures, ridge closures and hip closures.
5. Joint Type: As standard with manufacturer.
6. Panel Coverage: 15 inches (381 mm) to 16-1/2 inches (419 mm).

7. Panel Height: 1.5 inches (38 mm).

2.3 UNDERLAYMENT MATERIALS

- A. Self-Adhering, High-Temperature Underlayment: Provide self-adhering, cold-applied, sheet underlayment, a minimum of 30 mils (0.76 mm) thick, consisting of slip-resistant, polyethylene-film top surface laminated to a layer of butyl or SBS-modified asphalt adhesive, with release-paper backing. Provide primer when recommended by underlayment manufacturer.
 1. Thermal Stability: Stable after testing at 240 deg F (116 deg C); ASTM D1970.
 2. Low-Temperature Flexibility: Passes after testing at minus 20 deg F (29 deg C); ASTM D1970.
- B. Felt Underlayment: ASTM D 226/D 22M, Type II (No. 30), asphalt-saturated organic felts.

2.4 MISCELLANEOUS MATERIALS

- A. Panel Accessories: Provide components required for a complete, weathertight panel system including trim, copings, fasciae, mullions, sills, corner units, clips, flashings, sealants, gaskets, fillers, closure strips, and similar items. Match material and finish of metal panels unless otherwise indicated.
 1. Closures: Provide closures at eaves and ridges, fabricated of same metal as metal panels.
 2. Backing Plates: Provide metal backing plates at panel end splices, fabricated from material recommended by manufacturer.
 3. Weatherseal: Provide manufacturer's standard extruded vinyl weatherseal.
- B. Flashing and Trim: Provide flashing and trim formed from same material as metal panels as required to seal against weather and to provide finished appearance. Locations include, but are not limited to, eaves, rakes, corners, bases, framed openings, ridges, fasciae, and fillers. Finish flashing and trim with same finish system as adjacent metal panels.
- C. Panel Fasteners: Self-tapping screws designed to withstand design loads.
- D. Panel Sealants: Provide sealant type recommended by manufacturer that are compatible with panel materials, are nonstaining, and do not damage panel finish.
 1. Sealant Tape: Pressure-sensitive, 100 percent solids, gray polyisobutylene compound sealant tape with release-paper backing; 1/2 inch (13 mm) wide and 1/8 inch (3 mm) thick.
 2. Joint Sealant: ASTM C 920; as recommended in writing by metal panel manufacturer.

2.5 FABRICATION

- A. General: Fabricate and finish metal panels and accessories at the factory, by manufacturer's standard procedures and processes, as necessary to fulfill indicated performance requirements

demonstrated by laboratory testing. Comply with indicated profiles and with dimensional and structural requirements.

- B. On-Site Fabrication: Subject to compliance with requirements of this Section, metal panels may be fabricated on-site using UL-certified, portable roll-forming equipment if panels are of same profile and warranted by manufacturer to be equal to factory-formed panels. Fabricate according to equipment manufacturer's written instructions and to comply with details shown.
- C. Provide panel profile, including major ribs and intermediate stiffening ribs, if any, for full length of panel.
- D. Fabricate metal panel joints with factory-installed captive gaskets or separator strips that provide a weathertight seal and prevent metal-to-metal contact, and that minimize noise from movements.
- E. Sheet Metal Flashing and Trim: Fabricate flashing and trim to comply with manufacturer's recommendations and recommendations in SMACNA's "Architectural Sheet Metal Manual" that apply to design, dimensions, metal, and other characteristics of item indicated.

2.6 FINISHES

- A. Panels and Accessories:
 - 1. Two-Coat Fluoropolymer: Manufacturer's standard fluoropolymer finish containing not less than 70 percent PVDF resin by weight in color coat.
 - 2. Concealed Finish: White or light-colored acrylic or polyester backer finish.

PART 3 - EXECUTION

3.1 EXAMINATION

- A. Examine substrates, areas, and conditions, with Installer present, for compliance with requirements for installation tolerances, metal panel supports, and other conditions affecting performance of the Work.
- B. Proceed with installation only after unsatisfactory conditions have been corrected.

3.2 PREPARATION

- A. Miscellaneous Supports: Install any miscellaneous panel anchorages according to ASTM C 754 and metal panel manufacturer's written recommendations.

3.3 UNDERLAYMENT INSTALLATION

- A. Self-Adhering Sheet Underlayment: Apply primer if required by manufacturer. Comply with temperature restrictions of underlayment manufacturer for installation. Apply at locations

indicated below, wrinkle free, in shingle fashion to shed water, and with end laps of not less than 6 inches (152 mm) staggered 24 inches (610 mm) between courses. Overlap side edges not less than 3-1/2 inches (90 mm). Roll laps with roller. Cover underlayment within 14 days.

1. Apply over the roof area indicated below:
 - a. Roof perimeter for a distance up from eaves of 24 inches (610 mm) beyond interior wall line.
 - b. Valleys, from lowest point to highest point, for a distance on each side of 18 inches (460 mm). Overlap ends of sheets not less than 6 inches (152 mm).
 - c. Rake edges and roof-to-wall intersections for a distance of 18 inches (460 mm).
 - d. Hips and ridges for a distance on each side of 12 inches (305 mm).
 - e. Around dormers, chimneys, skylights, and other penetrating elements for a distance from element of 18 inches (460 mm).

- B. Felt Underlayment: Apply at locations indicated below, in shingle fashion to shed water, and with lapped joints of not less than 2 inches (50 mm).

1. Apply on roof not covered by self-adhering sheet underlayment. Lap over edges of self-adhering sheet underlayment not less than 3 inches (75 mm), in shingle fashion to shed water.

- C. Flashings: Install flashings to cover underlayment to comply with requirements specified in Section 076200 "Sheet Metal Flashing and Trim."

3.4 METAL PANEL INSTALLATION

- A. General: Install metal panels according to manufacturer's written instructions in orientation, sizes, and locations indicated. Install panels perpendicular to supports unless otherwise indicated. Anchor metal panels and other components of the Work securely in place, with provisions for thermal and structural movement.

1. Shim or otherwise plumb substrates receiving metal panels.
2. Flash and seal metal panels at perimeter of all openings. Fasten with self-tapping screws. Do not begin installation until air- or water-resistive barriers and flashings that will be concealed by metal panels are installed.
3. Install screw fasteners in predrilled holes.
4. Locate and space fastenings in uniform vertical and horizontal alignment.
5. Install flashing and trim as metal panel work proceeds.
6. Locate panel splices over, but not attached to, structural supports. Stagger panel splices and end laps to avoid a four-panel lap splice condition.
7. Align bottoms of metal panels and fasten with blind rivets, bolts, or self-tapping screws. Fasten flashings and trim around openings and similar elements with self-tapping screws.
8. Provide weathertight escutcheons for pipe- and conduit-penetrating panels.

- B. Fasteners:

1. Aluminum Panels: Use stainless-steel fasteners for surfaces exposed to the exterior.

- C. Anchor Clips: Anchor metal roof panels and other components of the Work securely in place, using manufacturer's approved fasteners according to manufacturers' written instructions.
- D. Metal Protection: Where dissimilar metals contact each other or corrosive substrates, protect against galvanic action as recommended in writing by metal panel manufacturer.
- E. Standing-Seam Metal Roof Panel Installation: Fasten metal roof panels to supports with concealed clips at each standing-seam joint at location, spacing, and with fasteners recommended in writing by manufacturer.
 - 1. Install clips to supports with self-tapping fasteners.
 - 2. Install pressure plates at locations indicated in manufacturer's written installation instructions.
 - 3. Seamed Joint: Crimp standing seams with manufacturer-approved, motorized seamer tool so clip, metal roof panel, and vinyl weatherseal are completely engaged.
 - 4. Watertight Installation: Install in strict accordance with manufacturer's instructions to meet specified warranty period.
- F. Accessory Installation: Install accessories with positive anchorage to building and weathertight mounting, and provide for thermal expansion. Coordinate installation with flashings and other components.
- G. Flashing and Trim: Comply with performance requirements, manufacturer's written installation instructions, and SMACNA's "Architectural Sheet Metal Manual." Provide concealed fasteners where possible, and set units true to line and level as indicated. Install work with laps, joints, and seams that will be permanently watertight and weather resistant.
- H. Gutters & Downspouts: Refer to Roof Specialties, Specification Section 077100 for requirements.

3.5 ERECTION TOLERANCES

- A. Installation Tolerances: Shim and align metal panel units within installed tolerance of 1/4 inch in 20 feet (6 mm in 6 m) on slope and location lines as indicated and within 1/8-inch (3-mm) offset of adjoining faces and of alignment of matching profiles.

3.6 CLEANING AND PROTECTION

- A. Remove temporary protective coverings and strippable films, if any, as metal panels are installed, unless otherwise indicated in manufacturer's written installation instructions. On completion of metal panel installation, clean finished surfaces as recommended by metal panel manufacturer. Maintain in a clean condition during construction.

END OF SECTION 074113.16

SECTION 074646 - FIBER-CEMENT SIDING

PART 1 - GENERAL

1.1 SUMMARY

- A. Section includes:
 - 1. Fiber-cement siding and soffit.
 - 2. Fiber-cement trim.
 - 3. Continuous soffit vents.

1.2 PREINSTALLATION MEETINGS

- A. Preinstallation Conference: Conduct conference at Project site.

1.3 ACTION SUBMITTALS

- A. Product Data: For each type of product.
- B. Samples: For fiber-cement siding and soffit including related accessories.

1.4 INFORMATIONAL SUBMITTALS

- A. Product certificates.
- B. Product test reports.
- C. Research/evaluation reports.
- D. Sample warranty.

1.5 CLOSEOUT SUBMITTALS

- A. Maintenance data.

1.6 QUALITY ASSURANCE

- A. Mockups: Build mockups to verify selections made under Sample submittals and to demonstrate aesthetic effects and to set quality standards for fabrication and installation.
 - 1. Build mockup of typical wall with each fiber-cement siding, panel and soffit products. Mockup to include running and corner trim.

2. Approval of mockups does not constitute approval of deviations from the Contract Documents contained in mockups unless Architect specifically approves such deviations in writing.
3. Subject to compliance with requirements, approved mockups may become part of the completed Work if undisturbed at time of Substantial Completion.

1.7 DELIVERY, STORAGE, AND HANDLING

- A. Deliver and store packaged materials in original containers with labels intact until time of use.
- B. Store materials on elevated platforms, under cover, and in a dry location.

1.8 WARRANTY

- A. Special Warranty: Manufacturer agrees to repair or replace products that fail in materials or workmanship within specified warranty period.
 1. Warranty Period: 10 years from date of Substantial Completion.

PART 2 - PRODUCTS

2.1 FIBER-CEMENT SIDING

- A. General: ASTM C 1186, Type A, Grade II, fiber-cement board, noncombustible when tested according to ASTM E 136; with a flame-spread index of 25 or less when tested according to ASTM E 84.
 1. Manufacturers: Subject to compliance with requirements, provide products by the following:
 - a. James Hardie Building Products, Inc., www.jameshardie.com
- B. Labeling: Provide fiber-cement siding that is tested and labeled according to ASTM C 1186 by a qualified testing agency acceptable to authorities having jurisdiction.
- C. Nominal Thickness: Not less than 5/16 inch (8 mm).
- D. Horizontal Pattern: Hardie Plank 8-1/4 inches (209 mm) wide in Select Cedarmill style.
 1. Plank Texture: Wood grain pattern.
 2. Exposure: 7 inches (178 mm).
 3. Color: Refer to Exterior Finish Materials schedule, Sheet A300.
- E. Horizontal Pattern: Hardie Shingle 48 inch- (1200 mm-) long x 15.25 inch- (387 mm-) wide sheets in Straight Edge Panel.
 1. Shingle Texture: Wood grain pattern.

2. Exposure: 7 inches (178 mm).
 3. Color: Refer to Exterior Finish Materials schedule, Sheet A300.
- F. Panel: Hardie Panel 48 inch (1200 mm-) x 96 inch (2400 mm) in Smooth style.
1. Panel Texture: Smooth.
 2. Color: Refer to Exterior Finish Materials schedule, Sheet A300.
- G. Factory Priming: Manufacturer's standard acrylic primer.

2.2 FIBER-CEMENT SOFFIT

- A. General: ASTM C 1186, Type A, Grade II, fiber-cement board, noncombustible when tested according to ASTM E 136; with a flame-spread index of 25 or less when tested according to ASTM E 84.
1. Manufacturers: Subject to compliance with requirements, provide products by the following:
 - a. James Hardie Building Products, Inc., www.jameshardie.com
- B. Non-Vented Smooth Hardie Soffit:
1. Nominal Thickness: Not less than 1/4 inch (6 mm).
 2. Pattern: 24-inch- (600-mm-) wide sheets with smooth texture.
 3. Color: Manufacturer's Statement Collection White.
- C. Non-Vented Beaded Porch Panel Hardie Soffit:
1. Nominal Thickness: Not less than 1/4 inch (6 mm).
 2. Pattern: 48-inch- (1200-mm-) wide sheets with smooth texture.
 3. Color: Manufacturer's Dream Collection White
- D. Factory priming is generally offered as an optional feature by manufacturers listed. Factory Priming: Manufacturer's standard acrylic primer.

2.3 ACCESSORIES

- A. Siding Accessories, General: Provide starter strips, edge trim, outside and inside corner caps, and other items as recommended by siding manufacturer for building configuration.
- B. Battens: Provide polypropylene corrugated battens for drainage and ventilation behind fiber-cement siding.
1. Manufacturer: duPont de Nemours and Company, DuPont RainVent Batten.
 2. Size: 3/8-inch by 1-5/8-inch.

- C. Decorative Accessories: Provide the following fiber-cement decorative accessories in Rustic Grain finish as indicated:
 - 1. Corner posts.
 - 2. Door and window casings.
 - 3. Moldings and trim.
 - 4. Custom ornamental woodwork.

- D. Flashing: Provide aluminum flashing complying with Section 076200 "Sheet Metal Flashing and Trim" at window and door heads and where indicated.
 - 1. Finish for Aluminum Flashing: High-performance organic finish.

- E. Fasteners: For fastening fiber cement siding to steel studs, use Type 410 stainless steel screws as manufactured by Simpson Strong-Tie. Provide sufficient fastener length for full bite into steel stud.

- F. Sealant: Provide manufacturer's standard color matched sealants.

- G. Insect Screening for Soffit Vents: PVC-coated, glass-fiber fabric, 18-by-14 or 18-by-16 (1.4-by-1.8- or 1.4-by-1.6-mm) mesh. Use for ¼-inch or larger holes and gaps without insect protection.

- H. Continuous Soffit/Eave Vents: Polypropylene in 4 foot long sections.
 - 1. Manufacturer: Cor-A-Vent. Inc., Mishawaka, In, www.cor-a-vent.com S400 Strip Vent, or approved equivalent.
 - 2. Net-Free Area: Not less than 10 sq. in./linear ft. (645 sq. cm/m).
 - 3. Thickness: 1 inch (24.5 mm).
 - 4. Width: 1-1/2 inches (38.1 mm).
 - 5. Color: White

PART 3 - EXECUTION

3.1 EXAMINATION

- A. Examine substrates for compliance with requirements for installation tolerances and other conditions affecting performance of fiber-cement siding and soffit and related accessories.

- B. Proceed with installation only after unsatisfactory conditions have been corrected.

3.2 PREPARATION

- A. Clean substrates of projections and substances detrimental to application.

3.3 INSTALLATION

- A. General: Comply with manufacturer's written installation instructions applicable to products and applications indicated unless more stringent requirements apply.
 - 1. Do not install damaged components.
 - 2. Install fasteners no more than 24 inches (600 mm) o.c.
- B. Install joint sealants as specified in Section 079200 "Joint Sealants" and to produce a weathertight installation.
- C. Install soffit/eave vents in accordance with manufacturer's instruction and in locations shown on drawings.
- D. Install custom ornamental simulated woodwork to comply with manufacturer's written instructions.
- E. Install with minimum number of joints as is practical, using full-length pieces from maximum lengths of lumber available. Do not use pieces less than 24 inches (610 mm) long, except where necessary.
 - 1. Use scarf joints for end-to-end joints.
 - 2. Stagger end joints in adjacent and related members.
- F. Fit exterior joints to exclude water. Cope at returns and miter at corners to produce tight-fitting joints, with full-surface contact throughout length of joint.

3.4 ADJUSTING AND CLEANING

- A. Remove damaged, improperly installed, or otherwise defective materials and replace with new materials complying with specified requirements.
- B. Clean finished surfaces according to manufacturer's written instructions and maintain in a clean condition during construction.

END OF SECTION 074646

THIS PAGE INTENSIONALLY LEFT BLANK

SECTION 075423 - THERMOPLASTIC POLYOLEFIN (TPO) ROOFING

PART 1 - GENERAL

1.1 SUMMARY

A. Section Includes:

1. Adhered thermoplastic polyolefin (TPO) roofing system including flashings and accessories.
2. Substrate board.
3. Roof insulation.
4. Flexible walkways.

1.2 DEFINITIONS

- A. Roofing Terminology: Definitions in ASTM D 1079 and glossary in NRCA's "The NRCA Roofing and Waterproofing Manual" apply to work of this Section.

1.3 PREINSTALLATION MEETINGS

- A. Preinstallation Roofing Conference: Conduct conference at Project site prior to scheduled commencement of the roofing installation and associated work, conduct a meeting with the installer, architect, owner, manufacturer's representative and any other persons directly involved with the performance of the work.

1.4 ACTION SUBMITTALS

- A. Product Data: For each type of product.
- B. Shop Drawings: For roofing system. Include plans, elevations, sections, details, and attachments to other work.
- C. Samples for Verification: For the following products:
1. Fabricated inside corner of sheet roofing with insulation, in color required, demonstrating seams in roofing and size as necessary to include a complete inside corner at parapet.
 2. Walkway pads, of color required.

1.5 INFORMATIONAL SUBMITTALS

- A. Certificates: Installer shall provide written documentation from the manufacturer of their authorization to install the roof system, and eligibility to obtain the warranty specified in this section.

- B. Research/Evaluation Reports: For components of roofing system, from ICC-ES.
- C. Sample Warranties: For manufacturer's special warranties.

1.6 CLOSEOUT SUBMITTALS

- A. Maintenance Data: For roofing system to include in maintenance manuals.

1.7 QUALITY ASSURANCE

- A. Installer Qualifications: A qualified firm that is approved, authorized, or licensed by roofing system manufacturer to install manufacturer's product and that is eligible to receive manufacturer's special warranty.

1.8 DELIVERY, STORAGE, AND HANDLING

- A. Ship membrane rolls horizontally on pallets, stacked pyramid style and banded.
- B. Store rolls horizontally on pallets or shelves and maintain in a dry location. Store all pail goods in their original undamaged containers in a clean, dry location within their specified temperature range.
- C. Do not expose materials to moisture in any form before, during or after delivery to the site. Reject delivery of materials that show evidence of contact with moisture.
- D. Use "breathable" type covers such as canvas tarpaulins to allow venting and protection from weather and moisture. Cover and protect materials at the end of each work day. Do not remove any protective tarpaulins until immediately before the material will be installed.

1.9 PROJECT CONDITIONS

- A. Proceed with roofing only when existing and forecasted weather conditions permit. Ambient temperatures must be above 45°F (7.2°C) when applying hot asphalt or water based adhesives.

1.10 WARRANTY

- A. Special Warranty: Single source coverage and no monetary limitation where manufacturer agrees to repair or replace components of roofing system that fail in materials or workmanship within specified warranty period.
 - 1. Warranty Period: 20 years from date of Substantial Completion.

PART 2 - PRODUCTS

2.1 MANUFACTURERS

- A. Manufacturers: Subject to compliance with requirements, provide products by one of the following:
1. Carlisle SynTec Incorporated.
 2. Firestone Building Products.
 3. GAF Materials Corporation, Pasippany, NJ, www.gaf.com; Basis of Design.
 4. GenFlex Roofing Systems.
- B. Source Limitations: Obtain components including roof insulation adhesives and fasteners for roofing system from manufacturer approved by membrane roofing manufacturer.

2.2 PERFORMANCE REQUIREMENTS

- A. Accelerated Weathering: Roofing system shall withstand 2000 hours of exposure when tested according to ASTM G 152, ASTM G 154, or ASTM G 155.
- B. Impact Resistance: Roofing system shall resist impact damage when tested according to ASTM D 3746 or ASTM D 4272.
- C. Roofing System Design: Tested by a qualified testing agency to resist the uplift pressures in accordance with FM I-90 and ASCE/SEI 7 requirements for wind pressures as indicated on Structural Drawings.
- D. Solar Reflectance Index: Not less than 78 when calculated according to ASTM E 1980, based on testing identical products by a qualified testing agency.
- E. Energy Star Listing: Roofing system shall be listed on the DOE's ENERGY STAR "Roof Products Qualified Product List" for low-slope roof products.
- F. Energy Performance: Roofing system shall have an initial solar reflectance index of not less than 0.70 and an emissivity of not less than 0.75 when tested according to CRRC-1.
- G. Exterior Fire-Test Exposure: ASTM E 108 or UL 790, Class A; for application and roof slopes indicated; testing by a qualified testing agency. Identify products with appropriate markings of applicable testing agency.
- H. Fire-Resistance Ratings: Comply with fire-resistance-rated assembly designs indicated. Identify all products with appropriate markings of applicable testing agency.

2.3 TPO ROOFING

- A. Fabric-Reinforced TPO Sheet: ASTM D 6878, Smooth type, polyester scrim-reinforced, uniform, flexible TPO sheet.

1. Thickness: 60 mils (1.5 mm), nominal, GAF EverGuard TPO.
2. Exposed Face Color: Energy Gray #322.

2.4 AUXILIARY ROOFING MATERIALS

- A. General: Auxiliary materials recommended by roofing system manufacturer for intended use and compatible with roofing.
1. Liquid-type auxiliary materials shall comply with VOC limits of authorities having jurisdiction.
 2. Adhesives and sealants that are not on the exterior side of weather barrier shall comply with the following limits for VOC content:
 - a. Plastic Foam Adhesives: 50 g/L.
 - b. Gypsum Board and Panel Adhesives: 50 g/L.
 - c. Multipurpose Construction Adhesives: 70 g/L.
 - d. Fiberglass Adhesives: 80 g/L.
 - e. Single-Ply Roof Membrane Adhesives: 250 g/L.
 - f. Single-Ply Roof Membrane Sealants: 450 g/L.
 - g. Nonmembrane Roof Sealants: 300 g/L.
 - h. Sealant Primers for Nonporous Substrates: 250 g/L.
 - i. Sealant Primers for Porous Substrates: 775 g/L.
 - j. Other Adhesives and Sealants: 250 g/L.
- B. Sheet Flashing: Manufacturer's standard, polyester scrim reinforced TPO sheet flashing, not less than 50 mils (1.27 mm) thick, minimum, of same color as TPO sheet.
- C. Bonding Adhesive: Manufacturer's standard, water based.
- D. Slip Sheet: Manufacturer's standard, of thickness required for application.
- E. Fasteners: Factory-coated steel fasteners and metal or plastic plates complying with corrosion-resistance provisions in FM Global 4470, designed for fastening roofing to substrate, and acceptable to roofing system manufacturer.
- F. Miscellaneous Accessories: Provide metal termination bars, metal battens, pourable sealers, preformed cone and vent sheet flashings, preformed inside and outside corner sheet flashings, T-joint covers, lap sealants, termination reglets, and all other accessories required for a complete roofing system.

2.5 SUBSTRATE BOARDS

- A. Substrate Board: ASTM C 1177/C 1177M, glass-mat, water-resistant gypsum substrate, Type X, 5/8 inch (16 mm) thick.
1. Georgia-Pacific Gypsum LLC, DensDeck Prime Roof Boards or approved equivalent.

- B. Fasteners: Factory-coated steel fasteners and metal or plastic plates complying with corrosion-resistance provisions in FM Global 4470, designed for fastening substrate board to roof deck.

2.6 ROOF INSULATION

- A. Polyisocyanurate Board Insulation: ASTM C 1289, Type II, Class 1, Grade 2, felt or glass-fiber mat facer on both major surfaces.
 - 1. Manufacturers: Subject to compliance with requirements, provide products by one of the following:
 - a. Carlisle SynTec Incorporated.
 - b. Firestone Building Products.
 - c. GAF Materials Corporation.
 - d. Johns Manville.
 - e. Rmax, Inc.
 - B. Tapered Insulation: Provide factory-tapered insulation boards where required for sloping to drain and fabricated to slope of 1/4 inch per 12 inches (1:48) or greater.
 - C. Provide preformed saddles, crickets, tapered edge strips, and other insulation shapes where indicated for sloping to drain. Fabricate to slopes indicated.

2.7 INSULATION ACCESSORIES

- A. Fasteners: Factory-coated steel fasteners and metal or plastic plates complying with corrosion-resistance provisions in FM Global 4470, designed for fastening roof insulation to substrate, and acceptable to roofing system manufacturer.
- B. Insulation Adhesive: Insulation manufacturer's recommended adhesive formulated to attach roof insulation to substrate or to another insulation layer.

2.8 ASPHALT MATERIALS

- A. Roofing Asphalt: ASTM D 312, Type III or Type IV or ASTM D 6152, SEBS modified.
- B. Asphalt Primer: ASTM D 41/D 41M.

2.9 WALKWAYS

- A. Flexible Walkways: Factory-formed, nonporous, heavy-duty, slip-resisting, surface-textured walkway pads, approximately 3/16 inch (5 mm) thick and acceptable to roofing system manufacturer.

PART 3 - EXECUTION

3.1 EXAMINATION

- A. Verify that the surfaces and site conditions are ready to receive work.
- B. Verify that the deck is supported and secured, clean and smooth, free of depressions, waves, or projections, and properly sloped to drains, valleys, eaves, scuppers or gutters.
- C. Verify that the deck surfaces are dry and free of ice or snow.
- D. Verify that all roof openings or penetrations through the roof are solidly set, and that all flashings are tapered.

3.2 ROOFING INSTALLATION, GENERAL

- A. Install roofing system according to roofing system manufacturer's current written instructions and as required to receive manufacturer's warranty.
- B. Start the application of membrane at the low point of the roof or at the drains, so that the flow of water is over or parallel to, but never against the laps
- C. Complete terminations and base flashings and provide temporary seals to prevent water from entering completed sections of roofing system at the end of the workday or when rain is forecast. Remove and discard temporary seals before beginning work on adjoining roofing.

3.3 SUBSTRATE BOARD INSTALLATION

- A. Install substrate board with long joints in continuous straight lines, perpendicular to roof slopes with end joints staggered between rows. Tightly butt substrate boards together.
 - 1. Fasten substrate board to top flanges of steel deck to resist uplift pressure at corners, perimeter, and field of roof according to roofing system manufacturers' written instructions.

3.4 INSULATION INSTALLATION

- A. Coordinate installing roofing system components so insulation is not exposed to precipitation or left exposed at the end of the workday.
- B. Install tapered insulation under area of roofing for crickets and to conform to slopes indicated. Refer to structural drawings for roof steel slopes.
- C. Install insulation under area of roofing to achieve required thickness. Provide a total minimum LTTR-Value of 30.0. Provide greater LTTR-Value where required by the Energy Code in-force at jurisdiction in which project is located. Where overall insulation thickness is greater than 3.00

inches (76.2 mm) or greater, install two or more layers with joints of each succeeding layer staggered from joints of previous layer a minimum of 6 inches (150 mm) in each direction.

- D. Adhered Insulation: Install each layer of insulation and adhere to substrate as follows:
 - 1. Set each layer of insulation in insulation adhesive, firmly pressing and maintaining insulation in place.

3.5 ADHERED ROOFING INSTALLATION

- A. Adhere roofing over area to receive roofing according to roofing system manufacturer's written instructions. Unroll roofing and allow to relax before retaining.
- B. Accurately align roofing, and maintain uniform side and end laps of minimum dimensions required by manufacturer. Stagger end laps.
- C. Bonding Adhesive: Apply to substrate and underside of roofing at rate required by manufacturer, and allow to partially dry before installing roofing. Do not apply to splice area of roofing.
- D. In addition to adhering, mechanically fasten roofing securely at terminations, penetrations, and perimeter of roofing.
- E. Seams: Clean seam areas, overlap roofing, and hot-air weld side and end laps of roofing and sheet flashings according to manufacturer's written instructions, to ensure a watertight seam installation.
 - 1. Test lap edges with probe to verify seam weld continuity. Apply lap sealant to seal cut edges of sheet.
 - 2. Verify field strength of seams a minimum of twice daily, and repair seam sample areas.
 - 3. Repair tears, voids, and lapped seams in roofing that do not comply with requirements.
- F. Spread sealant bed over deck-drain flange at roof drains, and securely seal roofing in place with clamping ring.

3.6 BASE FLASHING INSTALLATION

- A. Install sheet flashings and preformed flashing accessories, and adhere to substrates according to roofing system manufacturer's written instructions.
- B. Apply bonding adhesive to substrate and underside of sheet flashing at required rate, and allow to partially dry. Do not apply to seam area of flashing.
- C. Flash penetrations and field-formed inside and outside corners with cured or uncured sheet flashing.
- D. Clean seam areas, overlap, and firmly roll sheet flashings into the adhesive. Hot-air weld side and end laps to ensure a watertight seam installation.

- E. Terminate and seal top of sheet flashings and mechanically anchor to substrate through termination bars.

3.7 WALKWAY INSTALLATION

- A. Flexible Walkways: Install walkway products in locations indicated. Heat weld to substrate or adhere walkway products to substrate with compatible adhesive according to roofing system manufacturer's written instructions.

3.8 PROTECTING AND CLEANING

- A. Protect roofing system from damage and wear during remainder of construction period. When remaining construction does not affect or endanger roofing, inspect roofing for deterioration and damage, describing its nature and extent in a written report, with copies to Architect and Owner.
- B. Correct deficiencies in or remove roofing system that does not comply with requirements, repair substrates, and repair or reinstall roofing system to a condition free of damage and deterioration at time of Substantial Completion and according to warranty requirements.
- C. Clean overspray and spillage from adjacent construction using cleaning agents and procedures recommended by manufacturer of affected construction.

END OF SECTION 075423

SECTION 076200 - SHEET METAL FLASHING AND TRIM

PART 1 - GENERAL

1.1 SUMMARY

A. Section Includes:

1. Formed roof drainage sheet metal fabrications.
2. Formed low-slope roof sheet metal fabrications.
3. Formed steep-slope roof sheet metal fabrications.
4. Formed wall sheet metal fabrications.
5. Formed equipment support flashing.
6. Counterflashing

1.2 PREINSTALLATION MEETINGS

- A. Preinstallation Conference: Conduct conference at Project site.

1.3 ACTION SUBMITTALS

- A. Product Data: For each type of product indicated. Include construction details, material descriptions, dimensions of individual components and profiles, and finishes for each manufactured product and accessory.
- B. Shop Drawings: Show fabrication and installation layouts of sheet metal flashing and trim, including plans, elevations, expansion-joint locations, and keyed details. Distinguish between shop- and field-assembled work. Include the following:
1. Identification of material, thickness, weight, and finish for each item and location in Project.
 2. Details for forming sheet metal flashing and trim, including profiles, shapes, seams, and dimensions.
 3. Details for joining, supporting, and securing sheet metal flashing and trim, including layout of fasteners, cleats, clips, and other attachments. Include pattern of seams.
 4. Details of termination points and assemblies, including fixed points.
 5. Details of expansion joints and expansion-joint covers, including showing direction of expansion and contraction.
 6. Details of edge conditions, including eaves, ridges, valleys, rakes, crickets, and counterflashings as applicable.
 7. Details of connections to adjoining work.
- C. Samples: For each type of exposed finish required, prepared on Samples of size indicated below:

1. Sheet Metal Flashing: 12 inches (300 mm) long by actual width of unit, including finished seam and in required profile. Include fasteners, cleats, clips, closures, and other attachments.
2. Trim, Metal Closures, Expansion Joints, Joint Intersections, and Miscellaneous Fabrications: 12 inches (300 mm) long and in required profile. Include fasteners and other exposed accessories.

1.4 INFORMATIONAL SUBMITTALS

- A. Qualification Data: For qualified fabricator.
- B. Warranty: Sample of special warranty.

1.5 QUALITY ASSURANCE

- A. Fabricator Qualifications: Shop that employs skilled workers who custom fabricate sheet metal flashing and trim similar to that required for this Project and whose products have a record of successful in-service performance.
- B. Sheet Metal Flashing and Trim Standard: Comply with SMACNA's "Architectural Sheet Metal Manual" unless more stringent requirements are specified or shown on Drawings.
- C. Mockups: Build mockups to verify selections made under sample submittals and to demonstrate aesthetic effects and set quality standards for fabrication and installation.
 1. Build mockup of typical roof eave, including gutter, fascia, fascia trim and apron flashing, approximately 4 feet (1.3 m) long, including supporting construction cleats, seams, attachments, underlayment, and accessories.
 2. Approval of mockups does not constitute approval of deviations from the Contract Documents contained in mockups unless Architect specifically approves such deviations in writing.
 3. Approved mockups may become part of the completed Work if undisturbed at time of Substantial Completion.

1.6 DELIVERY, STORAGE, AND HANDLING

- A. Do not store sheet metal flashing and trim materials in contact with other materials that might cause staining, denting, or other surface damage. Store sheet metal flashing and trim materials away from uncured concrete and masonry.
- B. Protect strippable protective covering on sheet metal flashing and trim from exposure to sunlight and high humidity, except to the extent necessary for the period of sheet metal flashing and trim installation.

1.7 WARRANTY

- A. Special Warranty on Finishes: Manufacturer agrees to repair finish or replace sheet metal flashing and trim that shows evidence of deterioration of factory-applied finishes within specified warranty period.
 - 1. Finish Warranty Period: 20 years from date of Substantial Completion.

PART 2 - PRODUCTS

2.1 PERFORMANCE REQUIREMENTS

- A. General: Sheet metal flashing and trim assemblies as indicated shall withstand wind loads, structural movement, thermally induced movement, and exposure to weather without failure due to defective manufacture, fabrication, installation, or other defects in construction. Completed sheet metal flashing and trim shall not rattle, leak, or loosen, and shall remain watertight.
- B. Fabricate and install roof edge flashing and copings capable of resisting the wind forces according to the requirements of the Virginia Construction Code, 2009.
- C. Thermal Movements: Provide sheet metal flashing and trim that allows for thermal movements from ambient and surface temperature changes and prevents buckling, opening of joints, hole elongation, overstressing of components, failure of joint sealants, failure of connections and other detrimental effects. Provide clips that resist rotation and avoid shear stress as the result of thermal movements.
 - 1. Temperature Change (Range): 120 deg F (67 deg C), ambient; 180 deg F (100 deg C), material surfaces.

2.2 SHEET METALS

- A. General: Protect mechanical and other finishes on exposed surfaces from damage by applying a strippable, temporary protective film before shipping.
- B. Aluminum Sheet: ASTM B 209 (ASTM B 209M), alloy as standard with manufacturer for finish required, with temper as required to suit forming operations and performance required.
 - 1. As-Milled Finish: Mill finish for concealed locations.
 - 2. Surface: Smooth, flat.
 - 3. Factory Prime Coating: Where painting after installation is indicated, pretreat with white or light-colored, factory-applied, baked-on epoxy primer coat; minimum dry film thickness of 0.2 mil (0.005 mm).
 - 4. Exposed Coil-Coated Finishes:
 - a. Two-Coat Fluoropolymer: AAMA 620. Fluoropolymer finish containing not less than 70 percent PVDF resin by weight in color coat. Prepare, pretreat, and apply

coating to exposed metal surfaces to comply with coating and resin manufacturers' written instructions.

5. Color: As selected by Architect from manufacturer's full range.
 6. Concealed Finish: Pretreat with manufacturer's standard white or light-colored acrylic or polyester backer finish, consisting of prime coat and wash coat with a minimum total dry film thickness of 0.5 mil (0.013 mm).
- C. Metallic-Coated Steel Sheet: Restricted flatness steel sheet, metallic coated by the hot-dip process and prepainted by the coil-coating process to comply with ASTM A 755/A 755M.
1. Aluminum-Zinc Alloy-Coated Steel Sheet: ASTM A 792/A 792M, Class AZ50 coating designation, Grade 40 (Class AZM150 coating designation, Grade 275); structural quality.
 2. Surface: Smooth, flat.
 3. Exposed Coil-Coated Finish:
 - a. Two-Coat Fluoropolymer: AAMA 621. Fluoropolymer finish containing not less than 70 percent PVDF resin by weight in color coat. Prepare, pretreat, and apply coating to exposed metal surfaces to comply with coating and resin manufacturers' written instructions.
 4. Color: As selected by Architect from manufacturer's full range.
 5. Concealed Finish: Pretreat with manufacturer's standard white or light-colored acrylic or polyester backer finish, consisting of prime coat and wash coat with a minimum total dry film thickness of 0.5 mil (0.013 mm).

2.3 UNDERLAYMENT MATERIALS

- A. Polyethylene Sheet: 6-mil- (0.15-mm-) thick polyethylene sheet complying with ASTM D 4397.
- B. Slip Sheet: Building paper, 30 lb/100 sq. ft. (0.16-kg/sq. m) minimum, rosin sized.

2.4 MISCELLANEOUS MATERIALS

- A. General: Provide materials and types of fasteners, solder, welding rods, protective coatings, separators, sealants, and other miscellaneous items as required for complete sheet metal flashing and trim installation and recommended by manufacturer of primary sheet metal or manufactured item unless otherwise indicated.
- B. Fasteners: Wood screws, annular threaded nails, self-tapping screws, self-locking rivets and bolts, and other suitable fasteners designed to withstand design loads and recommended by manufacturer of primary sheet metal or manufactured item.
 1. General: Blind fasteners or self-drilling screws, gasketed, with hex-washer head.

- a. Exposed Fasteners: Heads matching color of sheet metal using plastic caps or factory-applied coating.
 - b. Blind Fasteners: High-strength aluminum or stainless-steel rivets suitable for metal being fastened.
 - c. Spikes and Ferrules: Same material as gutter; with spike with ferrule matching internal gutter width.
2. Fasteners for Aluminum: Aluminum or Series 300 stainless steel.
 3. Fasteners for Stainless-Steel Sheet: Series 300 stainless steel.
- C. Sealant Tape: Pressure-sensitive, 100 percent solids, gray polyisobutylene compound sealant tape with release-paper backing. Provide permanently elastic, nonsag, nontoxic, nonstaining tape 1/2 inch (13 mm) wide and 1/8 inch (3 mm) thick.
- D. Elastomeric Sealant: ASTM C 920, elastomeric polymer sealant; low modulus; of type, grade, class, and use classifications required to seal joints in sheet metal flashing and trim and remain watertight.
- E. Butyl Sealant: ASTM C 1311, single-component, solvent-release butyl rubber sealant; polyisobutylene plasticized; heavy bodied for hooked-type joints with limited movement.
- F. Epoxy Seam Sealer: Two-part, noncorrosive, aluminum seam-cementing compound, recommended by aluminum manufacturer for exterior nonmoving joints, including riveted joints.
- G. Bituminous Coating: Cold-applied asphalt emulsion complying with ASTM D 1187.
- H. Asphalt Roofing Cement: ASTM D 4586, asbestos free, of consistency required for application.

2.5 FABRICATION, GENERAL

- A. General: Custom fabricate sheet metal flashing and trim to comply with recommendations in SMACNA's "Architectural Sheet Metal Manual" that apply to design, dimensions, geometry, metal thickness, and other characteristics of item indicated. Fabricate items at the shop to greatest extent possible.
1. Fabricate sheet metal flashing and trim in thickness or weight needed to comply with performance requirements, but not less than that specified for each application and metal.
 2. Obtain field measurements for accurate fit before shop fabrication.
 3. Form sheet metal flashing and trim without excessive oil canning, buckling, and tool marks and true to line and levels indicated, with exposed edges folded back to form hems.
 4. Conceal fasteners and expansion provisions where possible. Exposed fasteners are not allowed on faces exposed to view.
- B. Fabrication Tolerances: Fabricate sheet metal flashing and trim that is capable of installation to a tolerance of 1/4 inch in 20 feet (6 mm in 6 m) on slope and location lines as indicated and within 1/8-inch (3-mm) offset of adjoining faces and of alignment of matching profiles.

- C. Sealed Joints: Form non-expansion but movable joints in metal to accommodate elastomeric sealant.
- D. Expansion Provisions: Where lapped expansion provisions cannot be used, form expansion joints of intermeshing hooked flanges, not less than 1 inch (25 mm) deep, filled with butyl sealant concealed within joints.
- E. Fabricate cleats and attachment devices of sizes as recommended by SMACNA's "Architectural Sheet Metal Manual" and by FMG Loss Prevention Data Sheet 1-49 for application, but not less than thickness of metal being secured.
- F. Seams: Fabricate nonmoving seams with flat-lock seams. Form seams and seal with elastomeric sealant unless otherwise recommended by sealant manufacturer for intended use. Rivet joints where necessary for strength.
- G. Do not use graphite pencils to mark metal surfaces.

2.6 ROOF DRAINAGE SHEET METAL FABRICATIONS

- A. Hanging Gutters: Fabricate to cross section indicated, complete with end pieces, outlet tubes, and other accessories as required. Fabricate in minimum 96-inch- (2400-mm-) long sections. Furnish flat-stock gutter spacers and gutter brackets fabricated from same metal as gutters, of size recommended by SMACNA but not less than twice the gutter thickness. Fabricate expansion joints, expansion-joint covers, and gutter accessories from same metal as gutters.
 - 1. Gutter Style: Rectangular type gutter, Style B.
 - 2. Expansion Joints: Lap type.
 - 3. Size: 4 inches wide.
 - 4. Hangers: Brackets with spacers.
 - 5. Accessories: Wire ball downspout strainer.
 - 6. Gutters with Girth up to 20 Inches (508 mm): Fabricate from the following materials:
 - a. Aluminum: Not less than 0.032 inch (0.81 mm) thick.
- B. Downspouts: Fabricate 2-inch by 3-inch rectangular downspouts complete with mitered elbows. Furnish with metal hangers, from same material as downspouts, and anchors.
 - 1. Manufactured Hanger Style: SMACNA figure designation 1-34A.
 - 2. Fabricate from the following materials:
 - a. Aluminum: Not less than 0.032 inch (0.81 mm) thick.

2.7 LOW-SLOPE ROOF SHEET METAL FABRICATIONS

- A. Roof to Wall Transition, Roof to Roof Edge Flashing, and Expansion-Joint Cover: Fabricate from the following materials:
 - 1. Aluminum: 0.050 inch (1.27 mm) thick.

- B. Base Flashing: Fabricate from the following materials:
 - 1. Aluminum: 0.040 inch (1.02 mm) thick.
- C. Counterflashing: Fabricate from the following materials:
 - 1. Aluminum: 0.032 inch (0.81 mm) thick.
- D. Roof-Penetration and Roof-Drain Flashing: Fabricate from the following materials:
 - 1. Aluminum-Zinc Alloy-Coated Steel: 0.028 inch (0.71 mm) thick.

2.8 STEEP-SLOPE ROOF SHEET METAL FABRICATIONS

- A. Roof to Wall Fascia Transition, and Expansion-Joint Cover: Fabricate from the following materials:
 - 1. Aluminum: 0.050 inch (1.27 mm) thick.
- B. Apron, Step, Cricket, and Backer Flashing: Fabricate from the following materials:
 - 1. Aluminum: 0.032 inch (0.81 mm) thick.
- C. Drip Edges: Fabricate from the following materials:
 - 1. Aluminum: 0.032 inch (0.81 mm) thick.
- D. Eave, Rake, Ridge, and Hip Flashing: Fabricate from the following materials:
 - 1. Aluminum: 0.032 inch (0.81 mm) thick.
- E. Counterflashing: Fabricate from the following materials:
 - 1. Aluminum: 0.032 inch (0.81 mm) thick.
- F. Roof-Penetration Flashing: Fabricate from the following materials:
 - 1. Aluminum-Zinc Alloy-Coated Steel: 0.028 inch (0.71 mm) thick.

2.9 COUNTERFLASHINGS

- A. Counterflashings: Manufactured units of heights to overlap top edges of base flashings by 4 inches (100 mm) and in lengths not exceeding 12 feet (3.6 m)] designed to snap into through-wall-flashing receiver and compress against base flashings with joints lapped, from the following exposed metal:
 - 1. Formed Aluminum: 0.032 inch (0.81 mm) thick.
- B. Accessories:

1. Flexible-Flashing Retainer: Provide resilient plastic or rubber accessory to secure flexible flashing in reglet where clearance does not permit use of standard metal counterflashing or where reglet is provided separate from metal counterflashing.
2. Counterflashing Wind-Restraint Clips: Provide clips to be installed before counterflashing to prevent wind uplift of counterflashing lower edge.

C. Aluminum Finish: Two-coat fluoropolymer.

1. Color: As selected by Architect from manufacturer's full range.

2.10 MISCELLANEOUS SHEET METAL FABRICATIONS

A. Equipment Support Flashing: Fabricate from the following materials:

1. Aluminum: 0.032 inch (0.81 mm) thick.

B. Opening Flashings in Frame Construction: Fabricate head, sill, jamb, and similar flashings to extend 4 inches beyond wall openings. Form head and sill flashing with 2-inch-1 high, end dams. Fabricate from the following materials:

1. Aluminum: 0.032 inch (0.81 mm) thick.

C. Metal Wrap at Exterior Fascias and Other Locations Exposed to View: Fabricate from the following materials:

1. Aluminum: 0.032 inch (0.81 mm) thick.

PART 3 - EXECUTION

3.1 EXAMINATION

A. Examine substrates, areas, and conditions, with Installer present, to verify actual locations, dimensions and other conditions affecting performance of the Work.

1. Verify compliance with requirements for installation tolerances of substrates.
2. Verify that substrate is sound, dry, smooth, clean, sloped for drainage, and securely anchored.

B. Proceed with installation only after unsatisfactory conditions have been corrected.

3.2 UNDERLAYMENT INSTALLATION

A. Polyethylene Sheet: Install polyethylene sheet with adhesive for anchorage to minimize use of mechanical fasteners under sheet metal flashing and trim. Apply in shingle fashion to shed water, with lapped and taped joints of not less than 2 inches (50 mm).

3.3 INSTALLATION, GENERAL

- A. General: Anchor sheet metal flashing and trim and other components of the Work securely in place, with provisions for thermal and structural movement. Use fasteners, solder, welding rods, protective coatings, separators, sealants, and other miscellaneous items as required to complete sheet metal flashing and trim system.
1. Install sheet metal flashing and trim true to line and levels indicated. Provide uniform, neat seams with minimum exposure of solder, welds, and sealant.
 2. Install sheet metal flashing and trim to fit substrates and to result in watertight performance. Verify shapes and dimensions of surfaces to be covered before fabricating sheet metal.
 3. Space cleats not more than 12 inches (300 mm) apart. Anchor each cleat with two fasteners. Bend tabs over fasteners.
 4. Install exposed sheet metal flashing and trim without excessive oil canning, buckling, and tool marks.
 5. Install sealant tape where indicated.
 6. Torch cutting of sheet metal flashing and trim is not permitted.
 7. Do not use graphite pencils to mark metal surfaces.
- B. Metal Protection: Where dissimilar metals will contact each other or corrosive substrates, protect against galvanic action by painting contact surfaces with bituminous coating or by other permanent separation as recommended by SMACNA.
1. Coat back side of uncoated aluminum sheet metal flashing and trim with bituminous coating where flashing and trim will contact wood, ferrous metal, or cementitious construction.
 2. Underlayment: Where installing metal flashing directly on cementitious or wood substrates, install a course of polyethylene sheet.
- C. Expansion Provisions: Provide for thermal expansion of exposed flashing and trim. Space movement joints at a maximum of 10 feet (3 m) with no joints allowed within 24 inches (600 mm) of corner or intersection. Where lapped expansion provisions cannot be used or would not be sufficiently watertight, form expansion joints of intermeshing hooked flanges, not less than 1 inch (25 mm) deep, filled with sealant concealed within joints.
- D. Fastener Sizes: Use fasteners of sizes that will penetrate wood sheathing not less than 1-1/4 inches (32 mm) for nails and not less than 3/4 inch (19 mm) for wood screws.
- E. Seal joints as shown and as required for watertight construction.
1. Where sealant-filled joints are used, embed hooked flanges of joint members not less than 1 inch (25 mm) into sealant. Form joints to completely conceal sealant. When ambient temperature at time of installation is moderate, between 40 and 70 deg F (4 and 21 deg C), set joint members for 50 percent movement each way. Adjust setting proportionately for installation at higher ambient temperatures. Do not install sealant-type joints at temperatures below 40 deg F (4 deg C).
 2. Prepare joints and apply sealants to comply with requirements in Division 7 Section "Joint Sealants."

- F. Rivets: Rivet joints in uncoated aluminum where indicated and where necessary for strength.

3.4 ROOF DRAINAGE SYSTEM INSTALLATION

- A. General: Install sheet metal roof drainage items to produce complete roof drainage system according to SMACNA recommendations and as indicated. Coordinate installation of roof perimeter flashing with installation of roof drainage system.
- B. Hanging Gutters: Join sections with riveted and soldered joints or with lapped joints sealed with sealant. Provide for thermal expansion. Attach gutters at eave or fascia to firmly anchored gutter brackets spaced not more than 36 inches (900 mm) apart. Provide end closures and seal watertight with sealant. Slope to downspouts.
 - 1. Fasten gutter spacers to front and back of gutter.
 - 2. Loosely lock straps to front gutter bead and anchor to roof deck.
 - 3. Anchor and loosely lock back edge of gutter to continuous cleat.
 - 4. Install gutter with expansion joints at locations indicated, but not exceeding, 50 feet (15.24 m) apart. Install expansion-joint caps.
- C. Downspouts: Join sections with 1-1/2-inch (38-mm) telescoping joints.
 - 1. Provide hangers with fasteners designed to hold downspouts securely to walls. Locate hangers at top and bottom and at approximately 60 inches (1500 mm) o.c. in between.
 - 2. Provide elbows at base of downspout to direct water away from building.
 - 3. Connect downspouts to underground drainage system indicated.
- D. Expansion-Joint Covers: Install expansion-joint covers at locations and of configuration indicated. Lap joints a minimum of 4 inches (100 mm) in direction of water flow.

3.5 ROOF FLASHING INSTALLATION

- A. General: Install sheet metal flashing and trim to comply with performance requirements, sheet metal manufacturer's written installation instructions, and SMACNA's "Architectural Sheet Metal Manual." Provide concealed fasteners where possible, set units true to line, and level as indicated. Install work with laps, joints, and seams that will be permanently watertight and weather resistant.
- B. Roof Edge Flashing: Anchor to resist uplift and outward forces according to recommendations in FMG Loss Prevention Data Sheet 1-49 for specified wind zone and as indicated. Interlock bottom edge of roof edge flashing with continuous cleat anchored to substrate at 24-inch (600-mm) centers.
- C. Copings: Anchor to resist uplift and outward forces according to recommendations in FMG Loss Prevention Data Sheet 1-49 for specified wind zone and as indicated.
 - 1. Interlock exterior bottom edge of coping with continuous cleat anchored to substrate at 24-inch (600-mm) centers.

2. Anchor interior leg of coping with screw fasteners and washers at 24-inch (600-mm) centers.
 - D. Pipe or Post Counterflashing: Install counterflashing umbrella with close-fitting collar with top edge flared for elastomeric sealant, extending a minimum of 4 inches (100 mm) over base flashing. Install stainless-steel draw band and tighten.
- 3.6 Counterflashing: Coordinate installation of counterflashing with installation of base flashing. Insert counterflashing in reglets or receivers and fit tightly to base flashing. Extend counterflashing 4 inches (100 mm) over base flashing. Lap counterflashing joints a minimum of 4 inches (100 mm) and bed with sealant. Secure in a waterproof manner by means of interlocking folded seam or blind rivets and sealant.
- A. Roof-Penetration Flashing: Coordinate installation of roof-penetration flashing with installation of roofing and other items penetrating roof. Seal with butyl sealant and clamp flashing to pipes that penetrate roof.
- 3.7 MISCELLANEOUS FLASHING INSTALLATION
- A. Equipment Support Flashing: Coordinate installation of equipment support flashing with installation of roofing and equipment. Weld or seal flashing with elastomeric sealant to equipment support member.
- 3.8 ERECTION TOLERANCES
- A. Installation Tolerances: Shim and align sheet metal flashing and trim within installed tolerance of 1/4 inch in 20 feet (6 mm in 6 m) on slope and location lines as indicated and within 1/8-inch (3-mm) offset of adjoining faces and of alignment of matching profiles.
- 3.9 CLEANING AND PROTECTION
- A. Clean off excess sealants.
 - B. Remove temporary protective coverings and strippable films as sheet metal flashing and trim are installed unless otherwise indicated in manufacturer's written installation instructions. On completion of installation, remove unused materials and clean finished surfaces. Maintain in a clean condition during construction.
 - C. Replace sheet metal flashing and trim that have been damaged or that have deteriorated beyond successful repair by finish touchup or similar minor repair procedures.

END OF SECTION 076200

THIS PAGE INTENSIONALLY LEFT BLANK

SECTION 077200 - ROOF ACCESSORIES

PART 1 - GENERAL

1.1 SUMMARY

- A. Section Includes:
1. Roof curbs.
 2. Equipment supports.
 3. Roof hatches.

1.2 ACTION SUBMITTALS

- A. Product Data: For each type of roof accessory.
- B. Shop Drawings: For roof accessories.

PART 2 - PRODUCTS

2.1 ROOF CURBS

- A. Roof Curbs: Internally reinforced roof-curb units capable of supporting superimposed live and dead loads, including equipment loads and other construction indicated on Drawings, bearing continuously on roof structure, and capable of meeting performance requirements; with welded or mechanically fastened and sealed corner joints, integral metal cant, and integrally formed deck-mounting flange at perimeter bottom.
- B. Size: Coordinate dimensions with roughing-in information or Shop Drawings of equipment to be supported.
- C. Material: Zinc-coated (galvanized) steel sheet, 0.064 inch (1.63 mm) thick.
1. Finish: Mill phosphatized.
- D. Material: Aluminum sheet, 0.090 inch (2.28 mm) thick.
1. Finish: Mill.
- E. Construction:
1. Curb Profile: Manufacturer's standard compatible with roofing system.
 2. Fabricate curbs to minimum height of 12 inches (305 mm) above roofing surface unless otherwise indicated.

3. Top Surface: Level top of curb, with roof slope accommodated by sloping deck-mounting flange or by use of leveler frame.
4. Sloping Roofs: Where roof slope exceeds 1:48, fabricate curb with perimeter curb height tapered to accommodate roof slope so that top surface of perimeter curb is level. Equip unit with water diverter or cricket on side that obstructs water flow.
5. Insulation: Factory insulated with 1-1/2-inch- (38-mm-) thick glass-fiber board insulation.
6. Liner: Same material as curb, of manufacturer's standard thickness and finish.
7. Nailer: Factory-installed wood nailer along top flange of curb, continuous around curb perimeter.
8. Wind Restraint Straps and Base Flange Attachment: Provide wind restraint straps, welded strap connectors, and base flange attachment to roof structure at perimeter of curb, of size and spacing required to meet wind uplift requirements.
9. Platform Cap: Where portion of roof curb is not covered by equipment, provide weathertight platform cap formed from 3/4-inch- (19-mm-) thick plywood covered with metal sheet of same type, thickness, and finish as required for curb.
10. Metal Counterflashing: Manufacturer's standard, removable, fabricated of same metal and finish as curb.

2.2 EQUIPMENT SUPPORTS

- A. Equipment Supports: Internally reinforced perimeter metal equipment supports capable of supporting superimposed live and dead loads between structural supports, including equipment loads and other construction indicated on Drawings, spanning between structural supports; capable of meeting performance requirements; with welded or mechanically fastened and sealed corner joints, integral metal cant, and integrally formed structure-mounting flange at bottom.
- B. Size: Coordinate dimensions with roughing-in information or Shop Drawings of equipment to be supported.
- C. Material: Zinc-coated (galvanized) steel sheet, 0.064 inch (1.63 mm) thick.
 1. Finish: Mill phosphatized.
- D. Material: Aluminum sheet, 0.090 inch (2.28 mm) thick.
 1. Finish: Mill.
- E. Construction:
 1. Curb Profile: Manufacturer's standard compatible with roofing system.
 2. Insulation: Factory insulated with 1-1/2-inch- (38-mm-) thick glass-fiber board insulation.
 3. Liner: Same material as equipment support, of manufacturer's standard thickness and finish.
 4. Nailer: Factory-installed continuous wood nailers 3-1/2 inches (90 mm) wide on top flange of equipment supports, continuous around support perimeter.
 5. Wind Restraint Straps and Base Flange Attachment: Provide wind restraint straps, welded strap connectors, and base flange attachment to roof structure at perimeter of curb of size and spacing required to meet wind uplift requirements.

6. Platform Cap: Where portion of equipment support is not covered by equipment, provide weathertight platform cap formed from 3/4-inch- (19-mm-) thick plywood covered with metal sheet of same type, thickness, and finish as required for curb.
7. Metal Counterflashing: Manufacturer's standard, removable, fabricated of same metal and finish as equipment support.
8. Fabricate equipment supports to minimum height of 12 inches (305 mm) above roofing surface unless otherwise indicated.

2.3 ROOF HATCHES

- A. Roof Hatch (Scuttle): Metal roof-hatch units with lids and insulated double-walled curbs, welded or mechanically fastened and sealed corner joints, continuous lid-to-curb counterflashing and weathertight perimeter gasketing, straight sides and integrally formed deck-mounting flange at perimeter bottom.
 1. Manufacturers: Subject to compliance with requirements, provide products by the following or approved equivalent:
 - a. The BILCO Company, An Amesbury Truth Company, www.bilco.com, Type S-50-TB, thermally broke with curb, Bil-Clip flashing system, Bil-Guard 2.0 Safety Railing System #RL2-S and steel LadderUp Safety Post with yellow powder coat finish.
- B. Type and Size: Single-leaf lid, 36 by 30 inches (914 by 762 mm).
- C. Hatch Material: Aluminum sheet, 11 gauge.
 1. Finish: Mill.
- D. Construction:
 1. Insulation: 3-inch- (75-mm-) thick, polyisocyanurate board in cover and curb..
 2. Hatch Lid: Opaque, insulated, and double walled, with manufacturer's standard aluminum, 18 gauge liner of same finish as outer metal lid.
 3. Curb Liner: Manufacturer's standard, of same material and finish as metal curb.
 4. Fabricate insulated curbs to minimum height of 12 inches (305 mm) above roofing surface unless otherwise indicated.
- E. Fall Protection Safety Structure: Manufacturer's standard meeting impact load requirements of 29 CFR 1910.23 and authorities having jurisdiction, and manually openable from exterior without special tools.
- F. Hardware: Manufacturer's standard compression spring operators enclosed in telescopic tubes, hold-open arm, steel spring latch with turn handles, steel pintle-type hinge system, and padlock hasps inside and outside.
 1. Finish: Zinc plated/chromate sealed.

- G. Ladder-Assist Post: Roof-hatch manufacturer's standard painted steel device for attachment to roof-access ladder. Post locks in place on full extension; release mechanism returns post to closed position.

2.4 METAL MATERIALS

- A. Zinc-Coated (Galvanized) Steel Sheet: ASTM A 653/A 653M, G90 (Z275) coating designation and mill phosphatized for field painting where indicated.
 - 1. Mill-Phosphatized Finish: Manufacturer's standard for field painting.
 - 2. Factory Prime Coating for Roof Hatch: Apply pretreatment and alkyd base red oxide primer with a minimum dry film thickness of 0.2 mil (0.005 mm).
- B. Aluminum Sheet: ASTM B 209 (ASTM B 209M), manufacturer's standard alloy for finish required, with temper to suit forming operations and performance required.
 - 1. Mill Finish: As manufactured.
- C. Aluminum Extrusions and Tubes: ASTM B 221 (ASTM B 221M), manufacturer's standard alloy and temper for type of use, finished to match assembly where used; otherwise mill finished.
 - 1. Provide manufacturer's standard safety yellow powder-coat finish on roof hatch safety railing system.
- D. Steel Shapes: ASTM A 36/A 36M, hot-dip galvanized according to ASTM A 123/A 123M unless otherwise indicated.
- E. Galvanized-Steel Tube: ASTM A 500/A 500M, round tube, hot-dip galvanized according to ASTM A 123/A 123M.

2.5 MISCELLANEOUS MATERIALS

- A. General: Provide materials and types of fasteners, protective coatings, sealants, and other miscellaneous items required by manufacturer for a complete installation.
- B. Wood Nailers: Softwood lumber, pressure treated with waterborne preservatives for aboveground use, acceptable to authorities having jurisdiction, containing no arsenic or chromium, and complying with AWWA C2; not less than 1-1/2 inches (38 mm) thick.
- C. Underlayment:
 - 1. Felt: ASTM D 226/D 226M, Type II (No. 30), asphalt-saturated organic felt, nonperforated.
 - 2. Slip Sheet: Building paper, 3 lb/100 sq. ft. (0.16 kg/sq. m) minimum, rosin sized.
 - 3. Fasteners: Roof accessory manufacturer's recommended fasteners suitable for application and metals being fastened. Match finish of exposed fasteners with finish of material being

fastened. Provide nonremovable fastener heads to exterior exposed fasteners. Furnish the following unless otherwise indicated:

- D. Elastomeric Sealant: ASTM C 920, elastomeric polymer sealant as recommended by roof accessory manufacturer for installation indicated; low modulus; of type, grade, class, and use classifications required to seal joints and remain watertight.
- E. Asphalt Roofing Cement: ASTM D 4586/D 4586M, asbestos free, of consistency required for application.

PART 3 - EXECUTION

3.1 INSTALLATION

- A. General: Verify dimensions of roof openings for roof accessories. Install roof accessories according to manufacturer's written instructions.
 - 1. Install roof accessories level; plumb; true to line and elevation; and without warping, jogs in alignment, buckling, or tool marks.
 - 2. Anchor roof accessories securely in place so they are capable of resisting indicated loads.
 - 3. Use fasteners, separators, sealants, and other miscellaneous items as required to complete installation of roof accessories and fit them to substrates.
 - 4. Install roof accessories to resist exposure to weather without failing, rattling, leaking, or loosening of fasteners and seals.
- B. Metal Protection: Protect metals against galvanic action by separating dissimilar metals from contact with each other or with corrosive substrates by painting contact surfaces with bituminous coating or by other permanent separation as recommended by manufacturer.
 - 1. Coat concealed side of uncoated aluminum roof accessories with bituminous coating where in contact with wood, ferrous metal, or cementitious construction.
 - 2. Underlayment: Where installing roof accessories directly on cementitious or wood substrates, install a course of underlayment and cover with manufacturer's recommended slip sheet.
- C. Seal joints with elastomeric sealant as required by roof accessory manufacturer.

3.2 REPAIR AND CLEANING

- A. Galvanized Surfaces: Clean field welds, bolted connections, and abraded areas and repair galvanizing according to ASTM A 780/A 780M.
- B. Clean exposed surfaces according to manufacturer's written instructions.
- C. Replace roof accessories that have been damaged or that cannot be successfully repaired by finish touchup or similar minor repair procedures.

END OF SECTION 077200

THIS PAGE INTENSIONALLY LEFT BLANK

SECTION 077253 - SNOW GUARDS

PART 1 - GENERAL

1.1 SUMMARY

A. Section Includes:

1. Pad-type, seam-mounted snow guards.

1.2 ACTION SUBMITTALS

A. Product Data: For each type of product.

B. Shop Drawings: Include roof plans showing layouts and attachment details of snow guards.

1. Include calculation of number and location of snow guards based on snow load, roof slope, roof type, components, spacings, and finish.

C. Samples: Provide samples for each type of Snow Guard.

1.3 COORDINATION

A. Coordinate snow guards with roofing systems to be provided for final product selection, layout and installation to provide a leakproof, weathertight, secure, and noncorrosive installation.

1.4 WARRANTY

A. Special Warranty on Painted Finishes: Manufacturer agrees to repair finish or replace roof specialties that show evidence of deterioration of factory-applied finishes within specified warranty period.

1. Deterioration includes, but is not limited to, the following:

- a. Color fading more than 5 Hunter units when tested according to ASTM D 2244.
- b. Chalking in excess of a No. 8 rating when tested according to ASTM D 4214.
- c. Cracking, checking, peeling, or failure of paint to adhere to bare metal.

2. Finish Warranty Period: 10 years from date of Substantial Completion.

PART 2 - PRODUCTS

2.1 PERFORMANCE REQUIREMENTS

- A. Performance Requirements: Provide snow guards that withstand exposure to weather and resist thermally induced movement without failure, rattling, or fastener disengagement due to defective manufacture, fabrication, installation, or other defects in construction.
 - 1. Temperature Change: 180 deg F (100 deg C), material surfaces.
- B. Structural Performance:
 - 1. Snow Loads: As indicated on Structural Drawings.

2.2 PAD-TYPE SNOW GUARDS

- A. Seam-Mounted Metal Snow Guard Pads for Metal Roofs:
 - 1. Manufacturers: Subject to compliance with requirements, provide products by the following:
 - a. Berger Building Products, Inc., Model #SG-1 Snow Meister Snow Guard for Double Lock Standing Seam Metal Roof or Model SL-1 Snow Meister Snow Guard for Single Lock Standing Seam Metal Roof.
 - 2. Material: Cast Aluminum.
 - 3. Finish and Color: Manufacturer's standard E-Coat Epoxy in color to match standing seam metal roof.

PART 3 - EXECUTION

3.1 EXAMINATION

- A. Examine substrates and conditions, with Installer present, for compliance with requirements for installation tolerances, snow guard attachment, and other conditions affecting performance of the Work.
 - 1. Verify compatibility with and suitability of substrates including compatibility with existing finishes or primers.
- B. Proceed with installation only after unsatisfactory conditions have been corrected.

3.2 INSTALLATION

- A. Install snow guards according to manufacturer's written instructions. Space rows as indicated on drawings.

B. Attachment for Standing-Seam Metal Roofing:

1. Do not use fasteners that will penetrate metal roofing, or fastening methods that void metal roofing finish warranty.
2. Seam-Mounted Metal Snow Guard Pads: Cast aluminum clamps attached to vertical ribs of standing-seam metal roof panels.

END OF SECTION 077253

THIS PAGE INTENSIONALLY LEFT BLANK

SECTION 079200 - JOINT SEALANTS

PART 1 - GENERAL

1.1 SUMMARY

A. Section Includes:

1. Silicone joint sealants.
2. Urethane joint sealants.
3. Latex joint sealants.
4. Acoustical joint sealants.

1.2 ACTION SUBMITTALS

- A. Product Data: For each joint-sealant product indicated.
- B. Samples: For each kind and color of joint sealant required. Where colors are not selected, submit manufacturer's complete offering of actual sealant colors for selection.
- C. Joint-Sealant Schedule: Include the following information:
 1. Joint-sealant application, joint location, and designation.
 2. Joint-sealant manufacturer and product name.
 3. Joint-sealant color.

1.3 INFORMATIONAL SUBMITTALS

- A. Product test reports: Based on evaluation of comprehensive tests performed by a qualified testing agency, indicating that sealants comply with requirements.
- B. Warranties.

1.4 QUALITY ASSURANCE

- A. Installer Qualifications: Manufacturer's authorized representative who is trained and approved for installation of units required for this Project.
- B. Source Limitations: Obtain each kind of joint sealant from single source from single manufacturer.
- C. Preinstallation Conference: Conduct conference at Project site.

1.5 PROJECT CONDITIONS

- A. Do not proceed with installation of joint sealants under the following conditions:
1. When ambient and substrate temperature conditions are outside limits permitted by joint-sealant manufacturer or are below 40 deg F (5 deg C).
 2. When joint substrates are wet.
 3. Where joint widths are less than those allowed by joint-sealant manufacturer for applications indicated.
 4. Where contaminants capable of interfering with adhesion have not yet been removed from joint substrates.

1.6 WARRANTY

- A. Special Installer's Warranty: Manufacturer's standard form in which Installer agrees to repair or replace joint sealants that do not comply with performance and other requirements specified in this Section within specified warranty period.
1. Warranty Period: Two years from date of Substantial Completion.

PART 2 - PRODUCTS

2.1 MATERIALS, GENERAL

- A. Compatibility: Provide joint sealants, backings, and other related materials that are compatible with one another and with joint substrates under conditions of service and application, as demonstrated by joint-sealant manufacturer, based on testing and field experience.
- B. VOC Content of Interior Sealants: Sealants and sealant primers used inside the weatherproofing system shall comply with the following limits for VOC content when calculated according to 40 CFR 59, Subpart D (EPA Method 24):
1. Architectural Sealants: 250 g/L.
 2. Sealant Primers for Nonporous Substrates: 250 g/L.
 3. Sealant Primers for Porous Substrates: 775 g/L.
- C. Liquid-Applied Joint Sealants: Comply with ASTM C 920 and other requirements indicated for each liquid-applied joint sealant specified, including those referencing ASTM C 920 classifications for type, grade, class, and uses related to exposure and joint substrates.
- D. Stain-Test-Response Characteristics: Where sealants are specified to be nonstaining to porous substrates, provide products that have undergone testing according to ASTM C 1248 and have not stained porous joint substrates indicated for Project.

2.2 SILICONE JOINT SEALANTS

- A. Mildew-Resistant, Neutral-Curing Silicone Joint Sealant: ASTM C 920.

1. Manufacturers: Subject to compliance with requirements, [provide products by one of the following:
 - a. BASF Building Systems.
 - b. Dow Corning Corporation -786 Sealant M White.
 - c. GE Advanced Materials - Silicones.
 - d. Pecora Corporation.
 - e. Tremco Incorporated.
2. Type: Single component (S).
3. Grade: nonsag (NS).
4. Class: 25.
5. Uses Related to Exposure: Nontraffic (NT).

2.3 URETHANE JOINT SEALANTS

A. Urethane Joint Sealant: ASTM C 920, horizontal use

1. Manufacturers: Subject to compliance with requirements, provide products by one of the following:
 - a. BASF Building Systems.
 - b. Bostik, Inc.
 - c. Pecora Corporation.
 - d. Tremco Incorporated.
2. Type: Single component (S).
3. Grade: Pourable (P).
4. Class: 50.
5. Uses Related to Exposure: Traffic (T).

B. Urethane Joint Sealant: ASTM C 920, vertical use

1. Manufacturers: Subject to compliance with requirements, provide products by one of the following:
 - a. BASF Building Systems.
 - b. Bostik, Inc.
 - c. Pecora Corporation.
 - d. Tremco Incorporated.
2. Type: Single component (S).
3. Grade: Nonsag (NS).
4. Class: 25.
5. Uses Related to Exposure: Nontraffic (NT).

2.4 LATEX JOINT SEALANTS

- A. Latex Joint Sealant: Acrylic latex or siliconized acrylic latex, ASTM C 834, Type OP, Grade NF.
1. Manufacturers: Subject to compliance with requirements, provide products by one of the following:
 - a. BASF Building Systems.
 - b. Bostik, Inc.
 - c. Pecora Corporation.
 - d. Tremco Incorporated.

2.5 ACOUSTICAL JOINT SEALANTS

- A. Acoustical Joint Sealant: Manufacturer's standard nonsag, paintable, nonstaining latex sealant complying with ASTM C 834. Product effectively reduces airborne sound transmission through perimeter joints and openings in building construction as demonstrated by testing representative assemblies according to ASTM E 90.
1. Manufacturers: Subject to compliance with requirements, provide products by one of the following:
 - a. Pecora Corporation .
 - b. USG Corporation.

2.6 JOINT SEALANT BACKING

- A. Cylindrical Sealant Backings: ASTM C 1330, Type C (closed-cell material with a surface skin), Type O (open-cell material) or any of the preceding types, as approved in writing by joint-sealant manufacturer for joint application indicated, and of size and density to control sealant depth and otherwise contribute to producing optimum sealant performance.
- B. Bond-Breaker Tape: Polyethylene tape or other plastic tape recommended by sealant manufacturer.

2.7 MISCELLANEOUS MATERIALS

- A. Primer: Material recommended by joint-sealant manufacturer where required for adhesion of sealant to joint substrates indicated, as determined from preconstruction joint-sealant-substrate tests and field tests.
- B. Cleaners for Nonporous Surfaces: Chemical cleaners acceptable to manufacturers of sealants and sealant backing materials.
- C. Masking Tape: Nonstaining, nonabsorbent material compatible with joint sealants and surfaces adjacent to joints.

PART 3 - EXECUTION

3.1 PREPARATION

- A. Surface Cleaning of Joints: Clean out joints immediately before installing joint sealants to comply with joint-sealant manufacturer's written instructions.
 - 1. Remove laitance and form-release agents from concrete.
 - 2. Clean nonporous joint substrate surfaces with chemical cleaners or other means that do not stain, harm substrates, or leave residues capable of interfering with adhesion of joint sealants.
- B. Joint Priming: Prime joint substrates where recommended by joint-sealant manufacturer or as indicated by preconstruction joint-sealant-substrate tests or prior experience. Apply primer to comply with joint-sealant manufacturer's written instructions. Confine primers to areas of joint-sealant bond; do not allow spillage or migration onto adjoining surfaces.
- C. Masking Tape: Use masking tape where required to prevent contact of sealant or primer with adjoining surfaces that otherwise would be permanently stained or damaged by such contact or by cleaning methods required to remove sealant smears. Remove tape immediately after tooling without disturbing joint seal.

3.2 INSTALLATION

- A. Sealant Installation Standard: Comply with recommendations in ASTM C 1193 for use of joint sealants as applicable to materials, applications, and conditions indicated.
- B. Install sealant backings of kind indicated to support sealants during application and at position required to produce cross-sectional shapes and depths of installed sealants relative to joint widths that allow optimum sealant movement capability.
 - 1. Do not leave gaps between ends of sealant backings.
 - 2. Do not stretch, twist, puncture, or tear sealant backings.
 - 3. Remove absorbent sealant backings that have become wet before sealant application and replace them with dry materials.
- C. Install bond-breaker tape behind sealants where sealant backings are not used between sealants and backs of joints.
- D. Install sealants using proven techniques that comply with the following and at the same time backings are installed:
 - 1. Place sealants so they directly contact and fully wet joint substrates.
 - 2. Completely fill recesses in each joint configuration.
 - 3. Produce uniform, cross-sectional shapes and depths relative to joint widths that allow optimum sealant movement capability.

- E. Tooling of Nonsag Sealants: Immediately after sealant application and before skinning or curing begins, tool sealants according to requirements specified in subparagraphs below to form smooth, uniform beads of configuration indicated; to eliminate air pockets; and to ensure contact and adhesion of sealant with sides of joint.
1. Remove excess sealant from surfaces adjacent to joints.
 2. Use tooling agents that are approved in writing by sealant manufacturer and that do not discolor sealants or adjacent surfaces.
 3. Provide concave joint profile per Figure 8A in ASTM C 1193, unless otherwise indicated.
- F. Acoustical Sealant Installation: Comply with ASTM C 919 and with manufacturer's written recommendations.
- G. Clean off excess sealant or sealant smears adjacent to joints as the Work progresses by methods and with cleaning materials approved in writing by manufacturers of joint sealants and of products in which joints occur.

3.3 JOINT-SEALANT SCHEDULE

- A. Joint-Sealant Application: Exterior joints in horizontal traffic surfaces.
1. Joint Locations:
 - a. Isolation and contraction joints in cast-in-place concrete slabs.
 - b. Joints in paving units.
 - c. Joints between different materials listed above.
 2. Joint Sealant: Urethane, horizontal use.
 3. Joint-Sealant Color: As selected by Architect from manufacturer's full range of colors to match adjacent surface color.
- B. Joint-Sealant Application: Exterior joints in vertical surfaces and horizontal nontraffic surfaces.
1. Joint Locations:
 - a. Control joints in unit masonry, manufactured stone masonry, fiber-cement siding and trim, and cellular PVC trim
 - b. Joints between different materials listed above.
 - c. Perimeter joints between materials listed above and frames of doors and windows.
 2. Joint Sealant: Urethane, vertical use.
 3. Joint-Sealant Color: As selected by Architect from manufacturer's full range of colors to match adjacent surfaces color.
- C. Joint-Sealant Application: Interior joints in horizontal traffic surfaces.
1. Joint Locations:

- a. Control and joints in tile flooring.
 2. Joint Sealant: Urethane, horizontal use.
 3. Joint-Sealant Color: As selected by Architect from manufacturer's full range of colors.
- D. Joint-Sealant Application: Interior joints in vertical tile surfaces.
1. Joint Locations:
 - a. Tile control joints.
 2. Joint Sealant: Urethane, vertical use.
 3. Joint-Sealant Color: As selected by Architect from manufacturer's full range of colors.
- E. Joint-Sealant Application: Interior joints in vertical surfaces and horizontal nontraffic surfaces.
1. Joint Locations:
 - a. Control joints on exposed interior surfaces of exterior walls.
 - b. Perimeter joints of exterior openings where indicated.
 - c. Vertical joints on exposed surfaces of walls and partitions.
 - d. Perimeter joints between interior wall surfaces and frames of interior doors, windows and elevator entrances.
 2. Joint Sealant: Latex.
 3. Joint-Sealant Color: As selected by Architect from manufacturer's full range of colors.
- F. Joint-Sealant Application: Mildew-resistant interior joints in vertical surfaces and horizontal nontraffic surfaces.
1. Joint Sealant Location:
 - a. Joints between plumbing fixtures and adjoining walls, floors, and counters, and between countertops and backsplashes.
 2. Joint Sealant: Silicone.
 3. Joint-Sealant Color: White and clear
- G. Joint-Sealant Application: Interior acoustical joints in vertical surfaces and horizontal nontraffic surfaces.
1. Joint Location:
 - a. Acoustical joints at gypsum board partitions with Acoustic Insulation.
 2. Joint Sealant: Acoustical.
 3. Joint-Sealant Color: White.

END OF SECTION 079200

THIS PAGE INTENSIONALLY LEFT BLANK

SECTION 081113 - HOLLOW METAL FRAMES

PART 1 - GENERAL

1.1 RELATED DOCUMENTS

- A. Drawings and general provisions of the Contract, including General and Supplementary Conditions and Division 01 Specification Sections, apply to this Section.

1.2 SUMMARY

A. Section Includes:

1. Standard and custom hollow metal frames.
2. Steel sidelight, borrowed lite and transom frames.

B. Related Sections:

1. Division 01 Section "General Conditions".
2. Division 04 Section "Unit Masonry" for embedding anchors for hollow metal work into masonry construction.
3. Division 08 Section "Flush Wood Doors".
4. Division 08 Section "Stile and Rail Wood Doors".
5. Division 08 Section "Glazing" for glass view panels in hollow metal doors.
6. Division 08 Section "Door Hardware".
7. Division 09 Sections "Exterior Painting" and "Interior Painting" for field painting hollow metal doors and frames.
8. Division 28 Section "Access Control" for access control devices installed at door openings and provided as part of a security access control system.

C. Codes and References: Comply with the version year adopted by the Authority Having Jurisdiction.

1. ANSI/SDI A250.8 - Recommended Specifications for Standard Steel Doors and Frames.
2. ANSI/SDI A250.4 - Test Procedure and Acceptance Criteria for Physical Endurance for Steel Doors, Frames, Frames Anchors and Hardware Reinforcing.
3. ANSI/SDI A250.6 - Recommended Practice for Hardware Reinforcing on Standard Steel Doors and Frames.
4. ANSI/SDI A250.10 - Test Procedure and Acceptance Criteria for Prime Painted Steel Surfaces for Steel Doors and Frames.
5. ANSI/SDI A250.11 - Recommended Erection Instructions for Steel Frames.
6. ASTM A1008 - Standard Specification for Steel Sheet, Cold-Rolled, Carbon, Structural, High-Strength Low-Alloy and High-Strength Low-Alloy with Improved Formability.

7. ASTM A653 - Standard Specification for Steel Sheet, Zinc-Coated (Galvanized) or Zinc-Iron Alloy-Coated (Galvannealed) by the Hot-Dip Process.
8. ASTM A924 - Standard Specification for General Requirements for Steel Sheet, Metallic-Coated by the Hot-Dip Process.
9. ASTM C 1363 - Standard Test Method for Thermal Performance of Building Assemblies by Means of a Hot Box Apparatus.
10. ANSI/BHMA A156.115 - Hardware Preparation in Steel Doors and Frames.
11. ANSI/SDI 122 - Installation and Troubleshooting Guide for Standard Steel Doors and Frames.
12. ANSI/NFPA 80 - Standard for Fire Doors and Fire Windows; National Fire Protection Association.
13. ANSI/NFPA 105: Standard for the Installation of Smoke Door Assemblies.
14. NFPA 252 - Standard Methods of Fire Tests of Door Assemblies; National Fire Protection Association.
15. UL 10C - Positive Pressure Fire Tests of Door Assemblies.
16. UL 1784 - Standard for Air Leakage Tests of Door Assemblies.

1.3 SUBMITTALS

- A. Product Data: For each type of product indicated. Include construction details, material descriptions, core descriptions, hardware reinforcements, profiles, anchors, fire-resistance rating, and finishes.
- B. Door hardware supplier is to furnish templates, template reference number and/or physical hardware to the steel door and frame supplier in order to prepare the doors and frames to receive the finish hardware items.
- C. Shop Drawings: Include the following:
 1. Elevations of each frame design.
 2. Frame details for each frame type, including dimensioned profiles and metal thicknesses.
 3. Locations of reinforcement and preparations for hardware.
 4. Details of anchorages, joints, field splices, and connections.
 5. Details of accessories.
 6. Details of moldings, removable stops, and glazing.
 7. Details of conduit and preparations for power, signal, and control systems.
- D. Samples for Verification:
 1. Samples are only required by request of the architect and for manufacturers that are not current members of the Steel Door Institute.

1.4 QUALITY ASSURANCE

- A. Source Limitations: Obtain hollow metal doors and frames through one source from a single manufacturer wherever possible.

- B. Quality Standard: In addition to requirements specified, furnish SDI-Certified manufacturer products that comply with ANSI/SDI A250.8, latest edition, "Recommended Specifications for Standard Steel Doors and Frames".
- C. Fire-Rated Door Assemblies: Assemblies complying with NFPA 80 that are listed and labeled by a qualified testing agency, for fire-protection ratings indicated, based on testing at positive pressure according to UL10C (neutral pressure at 40" above sill) or UL 10C.
 - 1. Oversize Fire-Rated Door Assemblies Construction: For units exceeding sizes of tested assemblies, attach construction label certifying doors are built to standard construction requirements for tested and labeled fire rated door assemblies except for size.
 - 2. Temperature-Rise Limit: Where indicated and at vertical exit enclosures (stairwell openings) and exit passageways, provide doors that have a maximum transmitted temperature end point of not more than 450 deg F (250 deg C) above ambient after 30 minutes of standard fire-test exposure.
 - 3. Smoke Control Door Assemblies: Comply with NFPA 105.
 - a. Smoke "S" Label: Doors to bear "S" label, and include smoke and draft control gasketing applied to frame and on meeting stiles of pair doors.
- D. Fire-Rated, Borrowed-Light Frame Assemblies: Assemblies complying with NFPA 80 that are listed and labeled, by a testing and inspecting agency acceptable to authorities having jurisdiction, for fire-protection ratings indicated, based on testing according to NFPA 257. Provide labeled glazing material.
- E. Pre-Submittal Conference: Conduct conference in compliance with requirements in Division 01 Section "Project Meetings" with attendance by representatives of Supplier, Installer, and Contractor to review proper methods and procedures for installing hollow metal doors and frames and to verify installation of electrical knockout boxes and conduit at frames with electrified or access control hardware.

1.5 DELIVERY, STORAGE, AND HANDLING

- A. Deliver hollow metal work palletized, wrapped, or crated to provide protection during transit and Project site storage. Do not use non-vented plastic.
- B. Deliver welded frames with two removable spreader bars across bottom of frames, tack welded to jambs and mullions.
- C. Store hollow metal work under cover at Project site. Place in stacks of five units maximum in a vertical position with heads up, spaced by blocking, on minimum 4-inch high wood blocking. Do not store in a manner that traps excess humidity.
 - 1. Provide minimum 1/4-inch space between each stacked door to permit air circulation. Frames to be stacked in a vertical upright position.

1.6 PROJECT CONDITIONS

- A. Field Measurements: Verify actual dimensions of openings by field measurements before fabrication.

1.7 COORDINATION

- A. Coordinate installation of anchorages for hollow metal frames. Furnish setting drawings, templates, and directions for installing anchorages, including sleeves, concrete inserts, anchor bolts, and items with integral anchors. Deliver such items to Project site in time for installation.
- B. Building Information Modeling (BIM) Support: Utilize designated BIM software tools and obtain training needed to successfully participate in the Project BIM processes. All technical disciplines are responsible for the product data integration and data reliability of their Work into the coordinated BIM applications.

1.8 WARRANTY

- A. Special Warranty: Manufacturer's standard form in which manufacturer agrees to repair or replace frames that fail in materials or workmanship within specified warranty period.
- B. Warranty includes installation and finishing that may be required due to repair or replacement of defective doors.

PART 2 - PRODUCTS

2.1 MANUFACTURERS

- A. Manufacturers: Subject to compliance with requirements, provide steel frames from a SDI Certified manufacturer:
 - 1. CECO Door Products (CE).
 - 2. Curries Company (CU).
 - 3. Steelcraft (ST).

2.2 MATERIALS

- A. Cold-Rolled Steel Sheet: ASTM A 1008/A 1008M, Commercial Steel (CS), Type B; suitable for exposed applications.
- B. Metallic-Coated Steel Sheet: ASTM A 653/A 653M, Commercial Steel (CS), Type B; with minimum G60 (Z180) or A60 (ZF180) metallic coating.
- C. Frame Anchors: ASTM A 653/A 653M, Commercial Steel (CS), Commercial Steel (CS), Type B; with minimum G60 (Z180) or A60 (ZF180) metallic coating.

2.3 HOLLOW METAL DOORS

- A. General: Provide 1-3/4 inch doors of design indicated, not less than thickness indicated; fabricated with smooth surfaces, without visible joints or seams on exposed faces unless otherwise indicated. Comply with ANSI/SDI A250.8 and ANSI/NAAMM HMMA 867.

2.4 HOLLOW METAL FRAMES

- A. General: Comply with ANSI/SDI A250.8 and with details indicated for type and profile.
- B. Thermal Break Frames: Subject to the same compliance standards and requirements as standard hollow metal frames. Tested for thermal performance in accordance with NFRC 102, and resistance to air infiltration in accordance with NFRC 400. Where indicated provide thermally broken frame profiles available for use in both masonry and drywall construction. Fabricate with 1/16" positive thermal break and integral vinyl weatherstripping.
- C. Exterior Frames: Fabricated of hot-dipped zinc coated steel that complies with ASTM A 653/A 653M, Coating Designation A60.
 - 1. Fabricate frames with mitered or coped corners. Profile as indicated on drawings.
 - 2. Frames: Minimum 14 gauge (0.067-inch -1.7-mm) thick steel sheet.
 - 3. Manufacturers Basis of Design:
 - a. Curries Company (CU) - M Series.
- D. Interior Frames: Fabricated from cold-rolled steel sheet that complies with ASTM A 1008/A 1008M.
 - 1. Fabricate frames with mitered or coped corners. Profile as indicated on drawings.
 - 2. Frames: Minimum 16 gauge (0.053-inch -1.3-mm) thick steel sheet.
 - 3. Manufacturers Basis of Design:
 - a. Curries Company (CU) - M Series.
- E. Fire rated frames: Fabricate frames in accordance with NFPA 80, listed and labeled by a qualified testing agency, for fire-protection ratings indicated.
- F. Hardware Reinforcement: Fabricate according to ANSI/SDI A250.6 Table 4 with reinforcement plates from same material as frames.

2.5 FRAME ANCHORS

- A. Jamb Anchors:
 - 1. Masonry Type: Adjustable strap-and-stirrup or T-shaped anchors to suit frame size, formed from A60 metallic coated material, not less than 0.042 inch thick,

with corrugated or perforated straps not less than 2 inches wide by 10 inches long; or wire anchors not less than 0.177 inch thick.

2. Stud Wall Type: Designed to engage stud and not less than 0.042 inch thick.

B. Floor Anchors: Floor anchors to be provided at each jamb, formed from A60 metallic coated material, not less than 0.042 inches thick.

C. Mortar Guards: Formed from same material as frames, not less than 0.016 inches thick.

2.6 ACCESSORIES

A. Mullions and Transom Bars: Join to adjacent members by welding or rigid mechanical anchors.

B. Grout Guards: Formed from same material as frames, not less than 0.016 inches thick.

2.7 FABRICATION

A. Fabricate hollow metal work to be rigid and free of defects, warp, or buckle. Accurately form metal to required sizes and profiles, with minimum radius for thickness of metal. Where practical, fit and assemble units in manufacturer's plant. When shipping limitations so dictate, frames for large openings are to be fabricated in sections for splicing or splining in the field by others.

B. Tolerances: Fabricate hollow metal work to tolerances indicated in ANSI/SDI A250.8.

C. Hollow Metal Frames:

1. Shipping Limitations: Where frames are fabricated in sections due to shipping or handling limitations, provide alignment plates or angles at each joint, fabricated of same thickness metal as frames.

2. Welded Frames: Weld flush face joints continuously; grind, fill, dress, and make smooth, flush, and invisible.

a. Welded frames are to be provided with two steel spreaders temporarily attached to the bottom of both jambs to serve as a brace during shipping and handling. Spreader bars are for bracing only and are not to be used to size the frame opening.

3. Sidelight and Transom Bar Frames: Provide closed tubular members with no visible face seams or joints, fabricated from same material as door frame. Fasten members at crossings and to jambs by butt welding.

4. High Frequency Hinge Reinforcement: Provide high frequency hinge reinforcements at door openings 48-inches and wider with mortise butt type hinges at top hinge locations.

5. Continuous Hinge Reinforcement: Provide welded continuous 12 gauge straps for continuous hinges specified in hardware sets in Division 08 Section "Door Hardware".

6. Provide countersunk, flat- or oval-head exposed screws and bolts for exposed fasteners unless otherwise indicated for removable stops, provide security screws at exterior locations.
 7. Mortar Guards: Provide guard boxes at back of hardware mortises in frames at all hinges and strike preps regardless of grouting requirements.
 8. Floor Anchors: Weld anchors to bottom of jambs and mullions with at least four spot welds per anchor.
 9. Jamb Anchors: Provide number and spacing of anchors as follows:
 - a. Masonry Type: Locate anchors not more than 18 inches from top and bottom of frame. Space anchors not more than 32 inches o.c. and as follows:
 - 1) Two anchors per jamb up to 60 inches high.
 - 2) Three anchors per jamb from 60 to 90 inches high.
 - 3) Four anchors per jamb from 90 to 120 inches high.
 - 4) Four anchors per jamb plus 1 additional anchor per jamb for each 24 inches or fraction thereof above 120 inches high.
 - b. Stud Wall Type: Locate anchors not more than 18 inches from top and bottom of frame. Space anchors not more than 32 inches o.c. and as follows:
 - 1) Three anchors per jamb up to 60 inches high.
 - 2) Four anchors per jamb from 60 to 90 inches high.
 - 3) Five anchors per jamb from 90 to 96 inches high.
 - 4) Five anchors per jamb plus 1 additional anchor per jamb for each 24 inches or fraction thereof above 96 inches high.
 - 5) Two anchors per head for frames above 42 inches wide and mounted in metal stud partitions.
 10. Door Silencers: Except on weatherstripped or gasketed doors, drill stops to receive door silencers. Silencers to be supplied by frame manufacturer regardless if specified in Division 08 Section "Door Hardware".
 11. Bituminous Coating: Where frames are fully grouted with an approved Portland Cement based grout or mortar, coat inside of frame throat with a water based bituminous or asphaltic emulsion coating to a minimum thickness of 3 mils DFT, tested in accordance with UL 10C and applied to the frame under a 3rd party independent follow-up service procedure.
- D. Hardware Preparation: Factory prepare hollow metal work to receive template mortised hardware; include cutouts, reinforcement, mortising, drilling, and tapping according to the Door Hardware Schedule and templates furnished as specified in Division 08 Section "Door Hardware."
1. Locate hardware as indicated, or if not indicated, according to ANSI/SDI A250.8.
 2. Reinforce doors and frames to receive non-template, mortised and surface mounted door hardware.

3. Comply with applicable requirements in ANSI/SDI A250.6 and ANSI/DHI A115 Series specifications for preparation of hollow metal work for hardware.
4. Coordinate locations of conduit and wiring boxes for electrical connections with Division 26 Sections.

2.8 STEEL FINISHES

- A. Prime Finishes: Frames to be cleaned, and chemically treated to insure maximum finish paint adhesion. Surfaces of the door and frame exposed to view to receive a factory applied coat of rust inhibiting shop primer.
 1. Shop Primer: Manufacturer's standard, fast-curing, lead and chromate free primer complying with ANSI/SDI A250.10 acceptance criteria; recommended by primer manufacturer for substrate; and compatible with substrate and field-applied coatings.

PART 3 - EXECUTION

3.1 EXAMINATION

- A. Examine substrates, areas, and conditions, with Installer present, for compliance with requirements for installation tolerances and other conditions affecting performance of the Work.
- B. General Contractor to verify the accuracy of dimensions given to the steel door and frame manufacturer for existing openings or existing frames (strike height, hinge spacing, hinge back set, etc.).
- C. Proceed with installation only after unsatisfactory conditions have been corrected.

3.2 PREPARATION

- A. Remove welded in shipping spreaders installed at factory. Restore exposed finish by grinding, filling, and dressing, as required to make repaired area smooth, flush, and invisible on exposed faces.
- B. Prior to installation, adjust and securely brace welded hollow metal frames for square, level, twist, and plumb condition.
- C. Tolerances shall comply with SDI-117 "Manufacturing Tolerances Standard Steel Doors and Frames."
- D. Drill and tap frames to receive non-template, mortised, and surface-mounted door hardware.

3.3 INSTALLATION

- A. General: Install hollow metal work plumb, rigid, properly aligned, and securely fastened in place; comply with Drawings and manufacturer's written instructions.
- B. Hollow Metal Frames: Install hollow metal frames of size and profile indicated. Comply with ANSI/SDI A250.11 and NFPA 80 at fire rated openings.
 - 1. Set frames accurately in position, plumbed, leveled, aligned, and braced securely until permanent anchors are set. After wall construction is complete and frames properly set and secured, remove temporary braces, leaving surfaces smooth and undamaged. Shim as necessary to comply with installation tolerances.
 - 2. Floor Anchors: Provide floor anchors for each jamb and mullion that extends to floor, and secure with post-installed expansion anchors.
 - 3. Masonry Walls: Coordinate installation of frames to allow for solidly filling space between frames and masonry with mortar.
 - 4. Grout Requirements: Do not grout head of frames unless reinforcing has been installed in head of frame. Do not grout vertical or horizontal closed mullion members.
- C. Field Glazing: Comply with installation requirements in Division 08 Section "Glazing" and with hollow metal manufacturer's written instructions.

3.4 ADJUSTING AND CLEANING

- A. Final Adjustments: Check and readjust operating hardware items immediately before final inspection. Leave work in complete and proper operating condition. Remove and replace defective work, including hollow metal work that is warped, bowed, or otherwise unacceptable.
- B. Remove grout and other bonding material from hollow metal work immediately after installation.
- C. Prime-Coat and Painted Finish Touchup: Immediately after erection, sand smooth rusted or damaged areas of prime coat, or painted finishes, and apply touchup of compatible air drying, rust-inhibitive primer, zinc rich primer (exterior and galvanized openings) or finish paint.

END OF SECTION 081113

THIS PAGE INTENSIONALLY LEFT BLANK

SECTION 081423 – IMPACT RESISTANT INTERIOR PANEL DOORS

PART 1 - GENERAL

1.1 SUMMARY

A. Section Includes:

1. Solid-core panel doors with damage resistant engineered PETG sheet faces.
2. Factory machining for hardware.

1.2 ACTION SUBMITTALS

A. Product Data: For each type of product, including the following:

1. Door core materials and construction.
2. Door edge construction
3. Door sheet face.
4. Door louver.
5. Factory-machining criteria.

B. Shop Drawings: Indicate location, size, and hand of each door; elevation of each type of door; construction details not covered in Product Data; and the following:

1. Door schedule indicating door location, type, size, fire protection rating, and swing.
2. Door elevations, dimension and locations of hardware, lite and louver cutouts, and glazing thicknesses.
3. Dimensions and locations of blocking for hardware attachment.
4. Clearances and undercuts.

C. Samples: For engineered PETG door faces and stiles.

1.3 QUALITY ASSURANCE

A. Source Limitations: Obtain high impact resistant Acrovyn Door Systems Panel Doors through one source from a single manufacturer.

B. Quality Standard: Comply with WDMA Industry Standard (I.S. 1A-04 “Architectural Wood Flush Doors”).

1. Doors will meet performance attributes for the following performance duty level: Extra Heavy Duty.
2. Tolerances for warp, telegraphing, squareness and prefitting dimensions as per the latest edition of WDMA I.S.1A-04.

1.4 DELIVERY, STORAGE, AND HANDLING

- A. Deliver, store, protect and handle products under guidelines of WDMA and manufacturer's care and handling instructions.
- B. Package doors individually using foam interleaf and stack on pallet, not exceeding 15 doors per pallet.
- C. Mark each door with opening number used on shop drawings.
- D. Accept doors on site in manufacturer's standard packaging. Inspect for damage.
- E. Do not store doors in damp or wet areas. HVAC systems should be operating and balanced prior to arrival of doors. Acceptable humidity shall be no less than 25% or greater than 55%.
- F. Do not subject doors to extreme conditions or changes in heat, dryness or humidity in accordance with the latest edition of WDMA I.S.1A-04.
- G. Protect doors from exposure to natural and artificial light after delivery.
- H. Doors should be lifted and carried when being moved, not dragged across one another.

1.5 PROJECT CONDITIONS

- A. Environmental Limitations: Do not deliver, store, or install doors until building is enclosed, and wet work is complete, and HVAC system is operating and will maintain temperature and relative humidity at occupancy levels during the remainder of the construction period.
- B. HVAC systems should be operating and balanced prior to arrival of doors. Acceptable humidity shall be no less than 25% or greater than 55%. Note: Any claim for warp, bow, twist, or telegraphing may be denied if required humidity requirements are not maintained.

1.6 WARRANTY

- A. Special Warranty: Manufacturer's standard form in which manufacturer agrees to repair or replace doors deemed defective in materials or workmanship.
 - 1. Solid-Core Interior Doors: provide manufacturer's limited lifetime written warranty guarantee against warp, delamination and defects in materials and workmanship.
 - 2. "Edge of a Lifetime" Warranty: If an Acrovyn edge cover is damaged, Construction Specialties shall supply a replacement Acrovyn cover at no charge to the Owner. This special warranty begins 1 month after the construction/renovation project is complete. Labor not included.

PART 2 - PRODUCTS

2.1 SOLID-CORE IMPACT RESISTANT PANEL DOORS WITH ENGINEERED PETG SHEET FACES

A. Interior Panel Doors:

1. Manufacturers: Subject to compliance with requirements, provide products by the following:
 - a. Construction Specialties, Inc. Acrovyn® Door Systems (800) 972-7214, www.C-sgroup.com.
2. Non-rated, Impact Resistant Interior Panel Doors conforming to WDMA I.S.1A-04 and the following:
 - a. Thickness: 1-3/4" (+/- 1/16")
 - b. Core: Solid Core Lumber, no added urea formaldehyde content. Solid, interior stiles and rails bonded. Tops and bottoms factory sealed with an approved sealer to prevent moisture intrusion.
 - c. Crossbanding: FSC certified.
 - d. Replaceable door stiles: Shall be field replaceable if ever damaged by impact.
 - e. Profile of stiles shall be a minimum thickness of 3/4" for maximum durability and ease of replacement.
 - f. Replaceable door edge covers: Shall be field replaceable if ever damaged by impact. Shall be exclusive of fasteners to improve appearance.
 - g. Profile of edge covers shall be a minimum height/thickness of 3/4" for maximum durability and ease of replacement.
 - h. Panels recessed into face of door shall be to a depth of 5/16"
 - i. WDMA I.S.1A-04 Performance Duty Level: Extra Heavy Duty. Door stiles to meet or exceed the following performance testing to ensure hardware fastener holding strength:
 - 1) WDMA TM-8 "Hinge Loading Resistance" Extra Heavy Duty
 - 2) WDMA TM-10 Screw Holding Capacity" Extra Heavy Duty
 - j. Durability Performance: Cycle Slam WDMA TM-7, 1990 Extra Heavy Duty - 2,000,000 cycles to insure durability of entire door construction.
 - k. Face Veneer Wear Index - Abrasion Resistance Testing - ASTM D4060-90: 28,000 cycles to prove out resistant to scuffing and scratching.
 - l. Face Veneer Impact Resistance - ASTM D-4226: 86 in/lb. to confirm impact resistance of face finish.
3. Door Panel Design, Edge Design and Color:
 - a. Refer to drawings for panel designs and color of finish.
 - b. Panel design to be present on both faces of doors.
 - c. Door edge color to match door faces.
 - d. Edges must fully wrap the door's vertical stiles.

- e. Door edges will be exclusive of fasteners to improve appearance.
 - f. Profile of edges will be a minimum height/thickness of 3/4".
 - g. Edges must be flush with face of door.
 - h. Edges to include 1/4" radius edges.
4. Adhesives:
- a. Crossbanding to core adhesives will be urea formaldehyde free Type II.
 - b. Door faces are to be applied to the crossbanded core using Type I urea formaldehyde free adhesives.

2.2 LOUVERS

A. Metal Louvers:

1. Manufacturers: Subject to compliance with requirements, provide products by the following or approved equivalent:
 - a. Construction Specialties, Inc., Cranford, NJ (800) 631-7379, www.C-sgroup.com.
2. Blade Type: Vision-proof, inverted V.
3. Material: Aluminum extrusions and sheet, finished in manufacturer's powder coat system complying with AAMA-2605-5. Color to match panel door.

2.3 FABRICATION

A. Factory fit doors to suit frame-opening sizes indicated.

1. Comply with clearance requirements of referenced quality standard for fitting unless otherwise indicated.

B. Factory machine doors for hardware that is not surface applied.

1. Locate hardware to comply with DHI-WDHS-3.
2. Comply with final hardware schedules, door frame Shop Drawings, ANSI/BHMA-156.115-W, and hardware templates.
3. Coordinate with hardware mortises in metal frames, to verify dimensions and alignment before factory machining.
4. For doors scheduled to receive electrified locksets, provide factory-installed raceway and wiring to accommodate specified hardware.

C. Openings: Factory cut and trim openings through doors.

1. Louvers: Factory install louvers in prepared openings.

PART 3 - EXECUTION

3.1 INSTALLATION

- A. Hardware: For installation, see Section 087100 "Door Hardware."
- B. Install doors to comply with manufacturer's written instructions and referenced quality standard, and as indicated.
- C. Job-Fitted Doors:
 - 1. Align and fit doors in frames with uniform clearances and bevels as indicated below.
 - a. Do not trim stiles and rails in excess of limits set by manufacturer or permitted for fire-rated doors.
 - 2. Machine doors for hardware.
 - 3. Seal edges of doors, edges of cutouts, and mortises after fitting and machining.
 - 4. Clearances:
 - a. Provide 1/8 inch (3.2 mm) at heads, jambs, and between pairs of doors.
 - b. Provide 1/8 inch (3.2 mm) from bottom of door to top of decorative floor finish or covering unless otherwise indicated on Drawings.
 - c. Where threshold is shown or scheduled, provide 1/4 inch (6.4 mm) from bottom of door to top of threshold unless otherwise indicated.
 - 5. Bevel non-fire-rated doors 1/8 inch in 2 inches (3-1/2 degrees) at lock and hinge edges.
- D. Factory-Fitted Doors: Align in frames for uniform clearance at each edge.
- E. Factory-Finished Doors: Restore finish before installation if fitting or machining is required at Project site.

3.2 ADJUSTING

- A. Operation: Rehang or replace doors that do not swing or operate freely.
- B. Finished Doors: Replace doors that are damaged or that do not comply with requirements.

END OF SECTION 081423

THIS PAGE INTENSIONALLY LEFT BLANK

SECTION 08210 - FIBERGLASS DOORS

PART 1 - GENERAL

1.1 SUMMARY

- A. Section Includes:
 - 1. Fiberglass entry Doors.

1.2 ACTION SUBMITTALS

- A. Product Data: For each type of door indicated. Include details of construction, manufacturer's literature, images of door, compliance with referenced standards, specified performance and installation instructions.
- B. Shop Drawings: Submit manufacturer's shop drawings indicating dimensions, construction, component connections, anchorage methods and locations, accessories, hardware locations and installation details.
- C. Sample: Submit sample of door finish for texture and color.

1.3 QUALITY ASSURANCE

- A. Quality Standard: In addition to requirements specified, comply with ANSI/NWWDA I.S.1.

1.4 DELIVERY, STORAGE, AND HANDLING

- A. Comply with requirements of referenced standard and manufacturer's written instructions.

PART 2 - PRODUCTS

2.1 PERFORMANCE REQUIREMENTS

- A. Door Unit Air Leakage, NFRC 400, 1.57 psf (25 mph): 0,50 cfm per square foot of frame or less.
- B. Door Unit Water Penetration: Not water penetration through door unit when tested in accordance with ASTM F331 or ASTM E547 with water applied at rate of 5 gallons per hour per square foot of 0 psf.

2.2 FIBERGLASS DOORS AND FRAMES

- A. Manufacturers: Subject to compliance with requirements, provide the following Basis of Design product or approved equivalent product:
1. Therma-Tru Corp., Maumee, OH, www.thermatru.com.
- B. EnergyStar rated Hinged Entry Doors: 1/16 inch thick fiberglass-reinforced thermoset composite with lightly textured surface. Door edges are machinable kiln-dried pine, primed, lock edge reinforced with engineered lumber core, lockset area reinforced with solid blocking for hardware backup. Door bottom edge is moisture and decay resistant composite. Core is foamed-in-place polyurethane with a minimum density of 1.9 pcf. Comply with the following requirements:
1. Product: Entry Door, Smooth-Star. Refer to drawings for door stile.
 2. Door Finish: Manufacturer's standard powder coat finish in color as selected by Architect.
 3. Glass: Low-E double pane, factory glazing.
 4. Hardware: Manufacturer's standard hinges and multi-point locking system including stainless steel face plate.
 - a. Finish of Hardware: US17A (black nickel).
 5. Sill: Aluminum with thermal break and kerf applied single bulb bottom sweep.
 - a. Finish of Sill: Mill
 6. Provide the following accessories:
 - a. ADA compliant threshold.
 - b. Sill pan.
 - c. Corner seal pad.
 - d. Rain deflector.
- C. Frame: Manufacturer's composite door, sidelite mullions and transom head frames with fiberglass finish to match fiberglass door.
1. Milled from 5/4 kiln-dried material with profiled 1/2 inch stop and 6 degree sill gain prep.
 2. Jamb Width: 7-1/16 inches, field verify prior to fabrication.
 3. Frames and mullions to be rot-resistant materials sourced through door manufacturer.

2.3 FABRICATION

- A. Fabricate fiberglass doors in accordance with ANSI/NWWDA I.S.1.
- B. Factory fit doors to suit frame-opening sizes indicated. Comply with clearance requirements of referenced quality standard for fitting unless otherwise indicated.
- C. Factory machine doors for hardware and provide hardware reinforcement for field installed surface hardware.

2.4 FACTORY FINISHING

- A. General: Comply with referenced quality standard for factory finishing. Complete fabrication, including fitting doors for openings and machining for hardware that is not surface applied, before finishing.
- B. Finish doors at factory.

PART 3 - EXECUTION

3.1 EXAMINATION

- A. Examine doors and installed door frames before hanging doors.
 - 1. Verify that frames comply with indicated requirements for type, size, location, and swing characteristics and have been installed with level heads and plumb jambs.
 - 2. Reject doors with defects.
- B. Proceed with installation only after unsatisfactory conditions have been corrected.

3.2 INSTALLATION

- A. Hardware: For installation, see Division 8 Section "Door Hardware."
- B. Installation Instructions: Install doors and frames to comply with manufacturer's written instructions and the referenced quality standard, and as indicated.
- C. Job-Fitted Doors: Align and fit doors in frames with uniform clearances and bevels as indicated below; do not trim stiles and rails in excess of limits set by manufacturer or permitted for fire-rated doors. Machine doors for hardware. Seal edges of doors, edges of cutouts, and mortises after fitting and machining.
 - 1. Clearances: Provide 1/8 inch (3.2 mm) at heads, jambs. Provide 1/8 inch (3.2 mm) from bottom of door to top of decorative floor finish or covering unless otherwise indicated. Where threshold is shown or scheduled, provide 1/4 inch (6.4 mm) from bottom of door to top of threshold unless otherwise indicated.
- D. Factory-Fitted Doors: Align in frames for uniform clearance at each edge.
- E. Factory-Finished Doors: Restore finish before installation if fitting or machining is required at Project site.

3.3 ADJUSTING

- A. Operation: Rehang or replace doors that do not swing or operate freely.

- B. Finished Doors: Replace doors that are damaged or that do not comply with requirements. Doors may be repaired or refinished if work complies with requirements and shows no evidence of repair or refinishing.

END OF SECTION 082100

THIS PAGE LEFT INTENSIONALLY BLANK

SECTION 083113 - ACCESS DOORS AND FRAMES

PART 1 - GENERAL

1.1 SUMMARY

- A. Section Includes:
1. Access doors and frames for walls and ceilings.
 2. Moisture resistant access doors

1.2 ACTION SUBMITTALS

- A. Product Data: For each type of product.
- B. Shop Drawings: Include plans, elevations, sections, details, and attachments to other work.
- C. Samples: Two full size access doors for each door face material.
- D. Schedule: Types, locations, sizes, latching or locking provisions, and other data pertinent to installation.

PART 2 - PRODUCTS

2.1 PERFORMANCE REQUIREMENTS

2.2 ACCESS DOORS AND FRAMES FOR WALLS AND CEILINGS

- A. Manufacturers: Subject to compliance with requirements, provide products by one of the following:
1. Access Panel Solutions.
 2. Babcock-Davis.
 3. Jensen Industries; Div. of Broan-Nutone, LLC.
 4. J. L. Industries, Inc.; Div. of Activar Construction Products Group.
 5. Karp Associates, Inc.
 6. Larsen's Manufacturing Company.
 7. Milcor Inc.
 8. Nystrom, Inc.
- B. Source Limitations: Obtain each type of access door and frame from single source from single manufacturer.
- C. Flush Access Doors with Concealed Flanges:

1. Assembly Description: Fabricate door to fit flush to frame. Provide frame with gypsum board beads for concealed flange installation.
2. Locations: Wall and ceiling.
3. Door Size: As required.
4. Uncoated Steel Sheet for Door: Nominal 0.060 inch (1.52 mm), 16 gage.
 - a. Finish: Factory prime.
5. Frame Material: Same material and thickness as door.
6. Hinges: Manufacturer's standard.
7. Hardware: Self-latching bolt operated by recessed screwdriver latch.

D. Moisture Resistant Access Doors (Non-rated):

1. Provide model #"L-MPSS" stainless steel frame and stainless steel door, by Larsen's Manufacturing Co. or approved equivalent.
2. Locations: Non-rated wall.
3. Door Size: As required to suit opening from manufacturer's standard sizes.
4. Mounting: Exposed Flange.
5. Materials: 304 stainless steel. #4 satin finish on exposed surfaces.
6. Hinges: Manufacturer's standard concealed continuous hinge.
7. Hardware: Self-latching bolt operated by recessed screwdriver latch.

2.3 MATERIALS

- A. Steel Plates, Shapes, and Bars: ASTM A 36/A 36M.
- B. Steel Sheet: Uncoated or electrolytic zinc coated, ASTM A 879/A 879M, with cold-rolled steel sheet substrate complying with ASTM A 1008/A 1008M, Commercial Steel (CS), exposed.
- C. Stainless Steel Sheet, Strip, Plate, and Flat Bars: ASTM A666, Type 304. Remove tool and die marks and stretch lines, or blend into finish.
- D. Frame Anchors: Same type as door face.
- E. Inserts, Bolts, and Anchor Fasteners: Hot-dip galvanized steel according to ASTM A 153/A 153M or ASTM F 2329.

2.4 FABRICATION

- A. General: Provide access door and frame assemblies manufactured as integral units ready for installation.
- B. Metal Surfaces: For metal surfaces exposed to view in the completed Work, provide materials with smooth, flat surfaces without blemishes. Do not use materials with exposed pitting, seam marks, roller marks, rolled trade names, or roughness.

- C. Doors and Frames: Grind exposed welds smooth and flush with adjacent surfaces. Furnish attachment devices and fasteners of type required to secure access doors to types of supports indicated.
- D. Latching Mechanisms: Furnish number required to hold doors in flush, smooth plane when closed.

2.5 FINISHES

- A. Comply with NAAMM's "Metal Finishes Manual for Architectural and Metal Products" for recommendations for applying and designating finishes.
- B. Protect mechanical finishes on exposed surfaces from damage by applying a strippable, temporary protective covering before shipping.
- C. Appearance of Finished Work: Noticeable variations in same piece are not acceptable. Variations in appearance of adjoining components are acceptable if they are within the range of approved Samples and are assembled or installed to minimize contrast.
- D. Steel and Metallic-Coated-Steel Finishes:
 - 1. Factory Prime: Apply manufacturer's standard, fast-curing, lead- and chromate-free, universal primer immediately after surface preparation and pretreatment.

PART 3 - EXECUTION

3.1 INSTALLATION

- A. Comply with manufacturer's written instructions for installing access doors and frames.
- B. Install doors flush with adjacent finish surfaces or recessed to receive finish material. Install frame plumb and level in wall and ceiling openings, flush with adjacent surfaces. Position to provide convenient access to concealed work requiring access. Secure rigidly in place.

3.2 ADJUSTING

- A. Adjust doors and hardware, after installation, for proper operation.
- B. Remove and replace doors and frames that are warped, bowed, or otherwise damaged.

3.3 TOUCH-UP

- A. Immediately after erection of work, sand smooth any rusted or damaged areas of prime coat and touch-up of compatible air drying primer.

3.4 PROTECTION AND CLEANING

- A. After installation, protect doors and frames from damage during subsequent construction activities. Damaged work will be rejected and shall be replaced with new work.
- B. Upon completion, metal surfaces of doors and frames that are completely factory finished shall be thoroughly cleaned and touched-up as recommended by the door manufacturer,

END OF SECTION 083113

SECTION 085313 - VINYL WINDOWS

PART 1 - GENERAL

1.1 SUMMARY

- A. Section includes vinyl-framed windows.

1.2 PREINSTALLATION MEETINGS

- A. Preinstallation Conference: Conduct conference at Project site.

1.3 ACTION SUBMITTALS

- A. Product Data: For each type of product.
- B. Shop Drawings: Include plans, elevations, sections, hardware, accessories, insect screens, operational clearances, and details of installation, including anchor, flashing, and sealant installation.
- C. Samples: For each exposed product and for each color specified.

1.4 INFORMATIONAL SUBMITTALS

- A. Product test reports.
- B. Sample warranties.

1.5 WARRANTY

- A. Manufacturer's Warranty: Manufacturer agrees to repair or replace vinyl windows that fail in materials or workmanship within specified warranty period.
 - 1. Warranty Period:
 - a. Window: Not less than 10 years from date of Substantial Completion.
 - b. Glazing Units: 10 years from date of Substantial Completion.

PART 2 - PRODUCTS

2.1 WINDOW PERFORMANCE REQUIREMENTS

- A. Product Standard: Comply with AAMA/WDMA/CSA 101/I.S.2/A440 for definitions and minimum standards of performance, materials, components, accessories, and fabrication unless more stringent requirements are indicated.
1. Window Certification: WDMA certified with label attached to each window.
- B. Performance Class and Grade: AAMA/WDMA/CSA 101/I.S.2/A440 as follows:
1. Minimum Performance Class: R-PG.
 2. Minimum Performance Grade: 35.
- C. Thermal Transmittance: NFRC 100 maximum whole-window U-factor of 0.22 Btu/sq. ft. x h x deg F (1.28 W/sq. m x K).
- D. Solar Heat-Gain Coefficient (SHGC): NFRC 200 maximum whole-window SHGC of 0.22.
- E. Windborne-Debris Impact Resistance: Passes ASTM E1886 missile-impact and cyclic-pressure tests in accordance with ASTM E1996 for Wind Zone 1 basic protection.
1. Large-Missile Test: For glazing located within 30 feet (9.1 m) of grade.

2.2 VINYL WINDOWS

- A. Manufacturers: Subject to compliance with requirements, provide the following Basis of Design product or approved equivalent product:
1. Pella Mid-Atlantic Windows & Doors, Beltsville, MD, 301-685-1715.
www.pellamidatlantic.com, 250 Series Single-Hung.
- B. Operating Types: Single-hung and fixed.
- C. Frames and Sashes: Impact-resistant, UV-stabilized PVC complying with AAMA/WDMA/CSA 101/I.S.2/A440.
1. Finish: Integral color, White Interior / White Exterior.
 2. Integral nailing fin with J-Channel.
 3. Gypsum Board Returns: Provide at interior face of frame.
- D. Insulating-Glass Units: ASTM E2190.
1. Glass: ASTM C1036, Type 1, Class 1, q3.
 - a. Tint: Clear.
 - b. Kind: Fully tempered where indicated on Drawings and as required by regulations.

2. Lites: Three.
 3. Filling: Fill space between glass lites with argon.
 4. Thickness: 1 inch (25.4 mm).
 5. Low-E Coating: Sputtered on second or third surface.
- E. Glazing System: Manufacturer's standard factory-glazing system that produces weathertight seal.
- F. Hardware, General: Provide manufacturer's standard corrosion-resistant hardware sized to accommodate sash weight and dimensions.
1. Exposed Hardware Color and Finish: As selected by Architect from manufacturer's full range.
- G. Hung Window Hardware:
1. Counterbalancing Mechanism: AAMA 902.
 2. Locks and Latches: Operated from the inside only.
 3. Tilt Hardware: Releasing tilt latch allows sash to pivot about horizontal axis.
 4. Factory Installed Limit Devices: Limit clear opening of operating sash to 4 inches (101.6 mm) for ventilation; with custodial key release.
- H. Weather Stripping: Provide full-perimeter weather stripping for each operable sash unless otherwise indicated.
- I. Fasteners: Noncorrosive and compatible with window members, trim, hardware, anchors, and other components. Do not use exposed fasteners.

2.3 ACCESSORIES

- A. Simulated Dividers (False Muntins): Provide divider grilles between the glass in design indicated for each sash lite.
1. Quantity and Type: One permanently located between insulating-glass lites where shown on drawings.
 2. Material: Manufacturer's standard aluminum.
 3. Pattern: Manufacturer's Traditional design.
 4. Profile: Manufacturer's 3/4 inch Contour Grille.
 5. Color: White Interior / White Exterior.

2.4 INSECT SCREENS

- A. General: Fabricate insect screens to integrate with window frame. Provide screen for each operable exterior sash. Screen wickets are not permitted.
1. Type and Location: Half, outside for single-hung sashes.

- B. Glass-Fiber Mesh Fabric: Manufacturer's standard mesh of PVC-coated, glass-fiber threads; woven and fused to form a fabric mesh resistant to corrosion, shrinkage, stretch, impact damage, and weather deterioration. Comply with ASTM D3656/D3656M.
 - 1. Mesh Color: Flat black.

2.5 FABRICATION

- A. Fabricate vinyl windows in sizes indicated. Include a complete system for installing and anchoring windows.
- B. Glaze vinyl windows in the factory.
- C. Weather strip each operable sash to provide weathertight installation.
- D. Mullions: Provide mullions and cover plates, compatible with window units, complete with anchors for support to structure and installation of window units. Allow for erection tolerances and provide for movement of window units due to thermal expansion and building deflections. Provide mullions and cover plates capable of withstanding design wind loads of window units. Provide manufacturer's standard finish to match window units.
- E. Hardware: Mount hardware through double walls of vinyl extrusions or provide corrosion-resistant reinforcement.
- F. Complete fabrication, assembly, finishing, hardware application, and other work in the factory to greatest extent possible. Disassemble components only as necessary for shipment and installation. Allow for scribing, trimming, and fitting at Project site.

PART 3 - EXECUTION

3.1 INSTALLATION

- A. Comply with manufacturer's written instructions for installing windows, hardware, accessories, and other components. For installation procedures and requirements not addressed in manufacturer's written instructions, comply with installation requirements in ASTM E2112.
- B. Install windows level, plumb, square, true to line, without distortion, anchored securely in place to structural support, and in proper relation to wall flashing and other adjacent construction to produce weathertight construction.
- C. Adjust operating sashes and hardware for a tight fit at contact points and weather stripping for smooth operation and weathertight closure.
- D. Clean exposed surfaces immediately after installing windows. Remove excess sealants, glazing materials, dirt, and other substances.

- E. Remove and replace sashes if glass has been broken, chipped, cracked, abraded, or damaged during construction period.

END OF SECTION 085313

THIS PAGE INTENSIONALLY LEFT BLANK

SECTION 087100 - DOOR HARDWARE

PART 1 - GENERAL

1.1 RELATED DOCUMENTS

- A. Drawings and general provisions of the Contract, including General and Supplementary Conditions and Division 1 Specification Sections, apply to this Section.

1.2 SUMMARY

- A. This Section includes commercial door hardware for the following:
 - 1. Swinging doors.
 - 2. Sliding doors.
 - 3. Other doors to the extent indicated.
- B. Door hardware includes, but is not necessarily limited to, the following:
 - 1. Mechanical door hardware.
 - 2. Electromechanical door hardware.
 - 3. Cylinders specified for doors in other sections.
- C. Related Sections:
 - 1. Division 08 Section "Hollow Metal Doors and Frames".
 - 2. Division 08 Section "Flush Wood Doors".
 - 3. Division 08 Section "Stile and Rail Wood Doors".
 - 4. Division 28 Section "Access Control Hardware Devices".
- D. Codes and References: Comply with the version year adopted by the Authority Having Jurisdiction.
 - 1. ANSI A117.1 - Accessible and Usable Buildings and Facilities.
 - 2. ICC/IBC - International Building Code.
 - 3. NFPA 70 - National Electrical Code.
 - 4. NFPA 80 - Fire Doors and Windows.
 - 5. NFPA 101 - Life Safety Code.
 - 6. NFPA 105 - Installation of Smoke Door Assemblies.
 - 7. State Building Codes, Local Amendments.

1.3 SUBMITTALS

- A. Product Data: Manufacturer's product data sheets including installation details, material descriptions, dimensions of individual components and profiles, operational descriptions and finishes.
- B. Door Hardware Schedule: Prepared by or under the supervision of supplier, detailing fabrication and assembly of door hardware, as well as procedures and diagrams. Coordinate the final Door Hardware Schedule with doors, frames, and related work to ensure proper size, thickness, hand, function, and finish of door hardware.
1. Format: Comply with scheduling sequence and vertical format in DHI's "Sequence and Format for the Hardware Schedule."
 2. Organization: Organize the Door Hardware Schedule into door hardware sets indicating complete designations of every item required for each door or opening. Organize door hardware sets in same order as in the Door Hardware Sets at the end of Part 3. Submittals that do not follow the same format and order as the Door Hardware Sets will be rejected and subject to resubmission.
 3. Content: Include the following information:
 - Type, style, function, size, label, hand, and finish of each door hardware item.
 - Manufacturer of each item.
 - Fastenings and other pertinent information.
 - Location of door hardware set, cross-referenced to Drawings, both on floor plans and in door and frame schedule.
 - Explanation of abbreviations, symbols, and codes contained in schedule.
 - Mounting locations for door hardware.
 - Door and frame sizes and materials.
 - Warranty information for each product.
 4. Submittal Sequence: Submit the final Door Hardware Schedule at earliest possible date, particularly where approval of the Door Hardware Schedule must precede fabrication of other work that is critical in the Project construction schedule. Include Product Data, Samples, Shop Drawings of other work affected by door hardware, and other information essential to the coordinated review of the Door Hardware Schedule.
- C. Shop Drawings: Details of electrified access control hardware indicating the following:
1. Wiring Diagrams: Upon receipt of approved schedules, submit detailed system wiring diagrams for power, signaling, monitoring, communication, and control of the access control system electrified hardware. Differentiate between manufacturer-installed and field-installed wiring. Include the following:
 - Elevation diagram of each unique access controlled opening showing location and interconnection of major system components with respect to their placement in the respective door openings.
 - Complete (risers, point-to-point) access control system block wiring diagrams.
 - Wiring instructions for each electronic component scheduled herein.

2. Electrical Coordination: Coordinate with related sections the voltages and wiring details required at electrically controlled and operated hardware openings.

D. Keying Schedule: After a keying meeting with the owner has taken place prepare a separate keying schedule detailing final instructions. Submit the keying schedule in electronic format. Include keying system explanation, door numbers, key set symbols, hardware set numbers and special instructions. Owner must approve submitted keying schedule prior to the ordering of permanent cylinders/cores.

E. Informational Submittals:

1. Product Test Reports: Indicating compliance with cycle testing requirements, based on evaluation of comprehensive tests performed by manufacturer and witnessed by a qualified independent testing agency.

F. Operating and Maintenance Manuals: Provide manufacturers operating and maintenance manuals for each item comprising the complete door hardware installation in quantity as required in Division 01, Closeout Procedures.

1.4 QUALITY ASSURANCE

A. Manufacturers Qualifications: Engage qualified manufacturers with a minimum 5 years of documented experience in producing hardware and equipment similar to that indicated for this Project and that have a proven record of successful in-service performance.

B. Certified Products: Where specified, products must maintain a current listing in the Builders Hardware Manufacturers Association (BHMA) Certified Products Directory (CPD).

C. Installer Qualifications: A minimum 3 years documented experience installing both standard and electrified door hardware similar in material, design, and extent to that indicated for this Project and whose work has resulted in construction with a record of successful in-service performance.

D. Door Hardware Supplier Qualifications: Experienced commercial door hardware distributors with a minimum 5 years documented experience supplying both mechanical and electromechanical hardware installations comparable in material, design, and extent to that indicated for this Project. Supplier recognized as a factory direct distributor by the manufacturers of the primary materials with a warehousing facility in Project's vicinity. Supplier to have on staff a certified Architectural Hardware Consultant (AHC) available during the course of the Work to consult with Contractor, Architect, and Owner concerning both standard and electromechanical door hardware and keying.

-
- E. Source Limitations: Obtain each type and variety of door hardware specified in this section from a single source unless otherwise indicated.
1. Electrified modifications or enhancements made to a source manufacturer's product line by a secondary or third party source will not be accepted.
 2. Provide electromechanical door hardware from the same manufacturer as mechanical door hardware, unless otherwise indicated.
- F. Each unit to bear third party permanent label demonstrating compliance with the referenced standards.
- G. Keying Conference: Conduct conference to comply with requirements in Division 01 Section "Project Meetings." Keying conference to incorporate the following criteria into the final keying schedule document:
1. Function of building, purpose of each area and degree of security required.
 2. Plans for existing and future key system expansion.
 3. Requirements for key control storage and software.
 4. Installation of permanent keys, cylinder cores and software.
 5. Address and requirements for delivery of keys.
- H. Pre-Submittal Conference: Conduct coordination conference in compliance with requirements in Division 01 Section "Project Meetings" with attendance by representatives of Supplier(s), Installer(s), and Contractor(s) to review proper methods and the procedures for receiving, handling, and installing door hardware.
1. Prior to installation of door hardware, conduct a project specific training meeting to instruct the installing contractors' personnel on the proper installation and adjustment of their respective products. Product training to be attended by installers of door hardware (including electromechanical hardware) for aluminum, hollow metal and wood doors. Training will include the use of installation manuals, hardware schedules, templates and physical product samples as required.
 2. Inspect and discuss electrical roughing-in, power supply connections, and other preparatory work performed by other trades.
 3. Review sequence of operation narratives for each unique access controlled opening.
 4. Review and finalize construction schedule and verify availability of materials.
 5. Review the required inspecting, testing, commissioning, and demonstration procedures
- I. At completion of installation, provide written documentation that components were applied to manufacturer's instructions and recommendations and according to approved schedule.

1.5 DELIVERY, STORAGE, AND HANDLING

- A. Inventory door hardware on receipt and provide secure lock-up and shelving for door hardware delivered to Project site. Do not store electronic access control hardware, software or accessories at Project site without prior authorization.
- B. Tag each item or package separately with identification related to the final Door Hardware Schedule, and include basic installation instructions with each item or package.
- C. Deliver, as applicable, permanent keys, cylinders, cores, access control credentials, software and related accessories directly to Owner via registered mail or overnight package service. Instructions for delivery to the Owner shall be established at the "Keying Conference".

1.6 COORDINATION

- A. Templates: Obtain and distribute to the parties involved templates for doors, frames, and other work specified to be factory prepared for installing standard and electrified hardware. Check Shop Drawings of other work to confirm that adequate provisions are made for locating and installing hardware to comply with indicated requirements.
- B. Door Hardware and Electrical Connections: Coordinate the layout and installation of scheduled electrified door hardware and related access control equipment with required connections to source power junction boxes, low voltage power supplies, detection and monitoring hardware, and fire and detection alarm systems.
- C. Door and Frame Preparation: Doors and corresponding frames are to be prepared, reinforced and pre-wired (if applicable) to receive the installation of the specified electrified, monitoring, signaling and access control system hardware without additional in-field modifications.

1.7 WARRANTY

- A. General Warranty: Reference Division 01, General Requirements. Special warranties specified in this Article shall not deprive Owner of other rights Owner may have under other provisions of the Contract Documents and shall be in addition to, and run concurrent with, other warranties made by Contractor under requirements of the Contract Documents.
- B. Warranty Period: Written warranty, executed by manufacturer(s), agreeing to repair or replace components of standard and electrified door hardware that fails in materials or workmanship within specified warranty period after final acceptance by the Owner. Failures include, but are not limited to, the following:
 - 1. Structural failures including excessive deflection, cracking, or breakage.

2. Faulty operation of the hardware.
 3. Deterioration of metals, metal finishes, and other materials beyond normal weathering.
 4. Electrical component defects and failures within the systems operation.
- C. Standard Warranty Period: One year from date of Substantial Completion, unless otherwise indicated.
- D. Special Warranty Periods:
1. Seven years for heavy duty cylindrical (bored) locks and latches.
 2. Five years for exit hardware.
 3. Twenty five years for manual overhead door closer bodies.
 4. Two years for electromechanical door hardware.

1.8 MAINTENANCE SERVICE

- A. Maintenance Tools and Instructions: Furnish a complete set of specialized tools and maintenance instructions as needed for Owner's continued adjustment, maintenance, and removal and replacement of door hardware.

PART 2 - PRODUCTS

2.1 SCHEDULED DOOR HARDWARE

- A. General: Provide door hardware for each door to comply with requirements in Door Hardware Sets and each referenced section that products are to be supplied under.
- B. Designations: Requirements for quantity, item, size, finish or color, grade, function, and other distinctive qualities of each type of door hardware are indicated in the Door Hardware Sets at the end of Part 3. Products are identified by using door hardware designations, as follows:
1. Named Manufacturer's Products: Product designation and manufacturer are listed for each door hardware type required for the purpose of establishing requirements. Manufacturers' names are abbreviated in the Door Hardware Schedule.
- C. Substitutions: Requests for substitution and product approval for inclusive mechanical and electromechanical door hardware in compliance with the specifications must be submitted in writing and in accordance with the procedures and time frames outlined in Division 01, Substitution Procedures. Approval of requests is at the discretion of the architect, owner, and their designated consultants.

2.2 HANGING DEVICES

- A. Hinges: ANSI/BHMA A156.1 certified butt hinges with number of hinge knuckles and other options as specified in the Door Hardware Sets.
1. Quantity: Provide the following hinge quantity:
Two Hinges: For doors with heights up to **60 inches**.
Three Hinges: For doors with heights **61 to 90 inches**.
Four Hinges: For doors with heights **91 to 120 inches**.
For doors with heights more than **120 inches**, provide 4 hinges, plus 1 hinge for every **30 inches** of door height greater than **120 inches**.
 2. Hinge Size: Provide the following, unless otherwise indicated, with hinge widths sized for door thickness and clearances required:
Widths up to 3'0": 4-1/2" standard or heavy weight as specified.
Sizes from 3'1" to 4'0": 5" standard or heavy weight as specified.
 3. Hinge Weight and Base Material: Unless otherwise indicated, provide the following:
Exterior Doors: Heavy weight, non-ferrous, ball bearing or oil impregnated bearing hinges unless Hardware Sets indicate standard weight.
Interior Doors: Standard weight, steel, ball bearing or oil impregnated bearing hinges unless Hardware Sets indicate heavy weight.
 4. Hinge Options: Comply with the following:
Non-removable Pins: Provide set screw in hinge barrel that, when tightened into a groove in hinge pin, prevents removal of pin while door is closed; for the all out-swinging lockable doors.
 5. Manufacturers:

McKinney Products (MK).
- B. Sliding and Folding Door Hardware: Hardware is to be of type and design as specified and should comply with ANSI/BHMA A156.14.
1. Sliding Bi-Passing Pocket Door Hardware: Provide complete sets consisting of track, hangers, stops, bumpers, floor channel, guides, and accessories indicated.
 2. Manufacturers:

Pemko Products (PE).

2.3 POWER TRANSFER DEVICES

- A. Electric Door Wire Harnesses: Provide electric/data transfer wiring harnesses with standardized plug connectors to accommodate up to twelve (12) wires. Connectors plug directly to through-door wiring harnesses for connection to electric locking devices and power supplies. Provide sufficient number and type of concealed wires to

accommodate electric function of specified hardware. Provide a connector for through-door electronic locking devices and from hinge to junction box above the opening. Wire nut connections are not acceptable. Determine the length required for each electrified hardware component for the door type, size and construction, minimum of two per electrified opening.

1. Provide one each of the following tools as part of the base bid contract:
McKinney Products (MK) - Electrical Connecting Kit: QC-R001.
McKinney Products (MK) - Connector Hand Tool: QC-R003.
2. Manufacturers:

McKinney Products (MK) - QC-C Series.

2.4 DOOR OPERATING TRIM

- A. Door Push Plate and Pulls: ANSI/BHMA A156.6 certified door pushes and pulls of type and design specified in the Hardware Sets. Coordinate and provide proper width and height as required where conflicting hardware dictates.
 1. Door Pull and Push Bar Design: Size, shape and material as indicated in the Hardware Sets. Minimum clearance of 2-1/2 inches from face of door unless otherwise indicated.
 2. Fasteners: Provide manufacturers designated fastener type as indicated in the Hardware Sets.
 3. Manufacturers:
Rockwood Products (RO)..

2.5 CYLINDERS AND KEYING

- A. General: Cylinder manufacturer to have minimum (10) years experience designing secured master key systems and have on record a published security keying system policy.
- B. Source Limitations: Obtain each type of keyed cylinder and keys from the same source manufacturer as locksets and exit devices, unless otherwise indicated.
 1. Manufacturers:
Corbin Russwin (RU).
- C. Cylinder Types: Original manufacturer cylinders able to supply the following cylinder formats and types:
 1. Threaded mortise cylinders with rings and cams to suit hardware application.
 2. Rim cylinders with back plate, flat-type vertical or horizontal tailpiece, and raised trim ring.
 3. Bored or cylindrical lock cylinders with tailpieces as required to suit locks.

4. Mortise and rim cylinder collars to be solid and recessed to allow the cylinder face to be flush and be free spinning with matching finishes.
 5. Keyway: Manufacturer's Standard.
- D. Removable Cores: Provide removable cores as specified, core insert, removable by use of a special key, and for use with only the core manufacturer's cylinder and door hardware.
- E. Keying System: Each type of lock and cylinders to be factory keyed.
1. Supplier shall conduct a "Keying Conference" to define and document keying system instructions and requirements.
 2. Furnish factory cut, nickel-silver large bow permanently inscribed with a visual key control number as directed by Owner.
 3. New System: Key locks to a new key system as directed by the Owner.
- F. Key Quantity: Provide the following minimum number of keys:
1. Change Keys per Cylinder: Three (3) each.
 2. Master Keys (per Master Key Level/Group): Five (5) each.
 3. Construction Keys: Ten (10) each.
 4. Construction Control Keys: Two (2) each.
 5. Permanent Control Keys: Two (2) each.
- G. Construction Keying: Provide temporary keyed brass construction cores.
- H. Key Registration List (Bitting List):
1. Provide keying transcript list to Owner's representative in the proper format for importing into key control software.
 2. Provide transcript list in writing or electronic file as directed by the Owner.

2.6 KEY CONTROL

- A. Key Control Cabinet: Provide a key control system including envelopes, labels, and tags with self-locking key clips, receipt forms, 3-way visible card index, temporary markers, permanent markers, and standard metal cabinet. Key control cabinet shall have expansion capacity of 150% of the number of locks required for the project.
1. Manufacturers:
 - a. Lund Equipment (LU).
 - b. MMF Industries (MM).
 - c. Telkee (TK).

2.7 MECHANICAL LOCKS AND LATCHING DEVICES

- A. Cylindrical Locksets, Grade 1 (Heavy Duty): ANSI/BHMA A156.2, Series 4000, Operational Grade 1 Certified Products Directory (CPD) listed.
1. Furnish with solid cast levers, standard 2 3/4" backset, and 1/2" (3/4" at rated paired openings) throw brass or stainless steel latchbolt.
 2. Locks are to be non-handed and fully field reversible.
 3. Extended cycle test: Locks to have been cycle tested in ordinance with ANSI/BHMA 156.2 requirements to 2 million cycles.
 4. Manufacturers:
Corbin Russwin (RU) - CL3300 Series.
- B. Cylindrical Locksets, Grade 1 (Commercial Duty): ANSI/BHMA A156.2, Series 4000, Operational Grade 1 Certified Products Directory (CPD) listed.
1. Locks are to be non-handed and fully field reversible.
 2. Manufacturers:
Corbin Russwin (RU) - CL3500 Series.

2.8 LOCK AND LATCH STRIKES

- A. Strikes: Provide manufacturer's standard strike with strike box for each latch or lock bolt, with curved lip extended to protect frame, finished to match door hardware set, unless otherwise indicated, and as follows:
1. Flat-Lip Strikes: For locks with three-piece antifriction latchbolts, as recommended by manufacturer.
 2. Extra-Long-Lip Strikes: For locks used on frames with applied wood casing trim.
 3. Aluminum-Frame Strike Box: Provide manufacturer's special strike box fabricated for aluminum framing.
- B. Standards: Comply with the following:
1. Strikes for Bored Locks and Latches: BHMA A156.2.

2.9 ELECTRIC STRIKES

- A. Standard Electric Strikes: Electric strikes tested to ANSI/BHMA A156.31, Grade 1, for use on non-rated or fire rated openings. Strikes shall be of stainless steel construction tested to a minimum of 1500 pounds of static strength and 70 foot-pounds of dynamic strength with a minimum endurance of 1 million operating cycles. Provide strikes with

12 or 24 VDC capability, fail-secure unless otherwise specified. Where specified provide latchbolt and latchbolt strike monitoring indicating both the position of the latchbolt and locked condition of the strike.

1. Manufacturers:

HES (HS) - 1006 Series.

- B. Surface Mounted Rim Electric Strikes: Surface mounted rim exit device electric strikes tested to ANSI/BHMA A156.31, Grade 1, and UL Listed for both Burglary Resistance and for use on fire rated door assemblies. Construction includes internally mounted solenoid with two heavy-duty, stainless steel locking mechanisms operating independently to provide tamper resistance. Strikes tested for a minimum of 500,000 operating cycles. Provide strikes with 12 or 24 VDC capability supplied standard as fail-secure unless otherwise specified. Option available for latchbolt and latchbolt strike monitoring indicating both the position of the latchbolt and locked condition of the strike. Strike requires no cutting to the jamb prior to installation.

1. Manufacturers:

HES (HS) - 9600 Series.

- C. Provide electric strikes with in-line power controller and surge suppressor by the same manufacturer as the strike with the combined products having a five year warranty.

2.10 CONVENTIONAL EXIT DEVICES

- A. General Requirements: All exit devices specified herein shall meet or exceed the following criteria:

1. At doors not requiring a fire rating, provide devices complying with NFPA 101 and listed and labeled for "Panic Hardware" according to UL305. Provide proper fasteners as required by manufacturer including sex nuts and bolts at openings specified in the Hardware Sets.
2. Where exit devices are required on fire rated doors, provide devices complying with NFPA 80 and with UL labeling indicating "Fire Exit Hardware". Provide devices with the proper fasteners for installation as tested and listed by UL. Consult manufacturer's catalog and template book for specific requirements.
3. Except on fire rated doors, provide exit devices with hex key dogging device to hold the pushbar and latch in a retracted position. Provide optional keyed cylinder dogging on devices where specified in Hardware Sets.
4. Devices must fit flat against the door face with no gap that permits unauthorized dogging of the push bar. The addition of filler strips is required in any case where the door light extends behind the device as in a full glass configuration.

5. Lever Operating Trim: Where exit devices require lever trim, furnish manufacturer's heavy duty escutcheon trim with threaded studs for thru-bolts.
Lock Trim Design: As indicated in Hardware Sets, provide finishes and designs to match that of the specified locksets.
Where function of exit device requires a cylinder, provide a cylinder (Rim or Mortise) as specified in Hardware Sets.
 6. Rail Sizing: Provide exit device rails factory sized for proper door width application.
- B. Conventional Push Rail Exit Devices (Heavy Duty): ANSI/BHMA A156.3, Grade 1 Certified Products Directory (CPD) listed panic and fire exit hardware devices furnished in the functions specified in the Hardware Sets. Exit device latch to be stainless steel, pullman type, with deadlock feature.
1. Manufacturers:

Corbin Russwin (RU) - ED5000 Series.

2.11 DOOR CLOSERS

- A. All door closers specified herein shall meet or exceed the following criteria:
1. General: Door closers to be from one manufacturer, matching in design and style, with the same type door preparations and templates regardless of application or spring size. Closers to be non-handed with full sized covers.
 2. Standards: Closers to comply with UL-10C for Positive Pressure Fire Test and be U.L. listed for use of fire rated doors.
 3. Size of Units: Comply with manufacturer's written recommendations for sizing of door closers depending on size of door, exposure to weather, and anticipated frequency of use. Where closers are indicated for doors required to be accessible to the Americans with Disabilities Act, provide units complying with ANSI ICC/A117.1.
 4. Closer Arms: Provide heavy duty, forged steel closer arms unless otherwise indicated in Hardware Sets.
 5. Closers shall not be installed on exterior or corridor side of doors; where possible install closers on door for optimum aesthetics.
 6. Closer Accessories: Provide door closer accessories including custom templates, special mounting brackets, spacers and drop plates as required for proper installation. Provide through-bolt and security type fasteners as specified in the hardware sets.

- B. Door Closers, Surface Mounted (Heavy Duty): ANSI/BHMA A156.4, Grade 1 Certified Products Directory (CPD) listed surface mounted, heavy duty door closers with complete spring power adjustment, sizes 1 thru 6; and fully operational adjustable according to door size, frequency of use, and opening force. Closers to be rack and pinion type, one piece cast iron or aluminum alloy body construction, with adjustable backcheck and separate non-critical valves for closing sweep and latch speed control. Provide non-handed units standard.

1. Manufacturers:

Corbin Russwin (RU) - DC6000 Series.

- C. Door Closers, Surface Mounted (Cam Action): ANSI/BHMA 156.4, Grade 1 Certified Products Directory (CPD) listed surface mounted, high efficiency door closers with complete spring power adjustment, sizes 1 thru 6; and fully operational adjustable according to door size, frequency of use, and opening force. Closers to be of the cam and roller design, one piece cast aluminum silicon alloy body with adjustable backcheck and independently controlled valves for closing sweep and latch speed.

1. Manufacturers:

Corbin Russwin (RU) - DC5000 Series.

2.12 ARCHITECTURAL TRIM

- A. Door Protective Trim

1. General: Door protective trim units to be of type and design as specified below or in the Hardware Sets.
2. Size: Fabricate protection plates (kick, armor, or mop) not more than 2" less than door width (LDW) on stop side of single doors and 1" LDW on stop side of pairs of doors, and not more than 1" less than door width on pull side. Coordinate and provide proper width and height as required where conflicting hardware dictates. Height to be as specified in the Hardware Sets.
3. Where plates are applied to fire rated doors with the top of the plate more than 16" above the bottom of the door, provide plates complying with NFPA 80. Consult manufacturer's catalog and template book for specific requirements for size and applications.
4. Protection Plates: ANSI/BHMA A156.6 certified protection plates (kick, armor, or mop), fabricated from the following:

Brass or Bronze: 050-inch thick.

5. Options and fasteners: Provide manufacturer's designated fastener type as specified in the Hardware Sets. Provide countersunk screw holes.

6. Manufacturers:

Rockwood Products (RO).

2.13 DOOR STOPS AND HOLDERS

A. General: Door stops and holders to be of type and design as specified below or in the Hardware Sets.

B. Door Stops and Bumpers: ANSI/BHMA A156.16, Grade 1 certified door stops and wall bumpers. Provide wall bumpers, either convex or concave types with anchorage as indicated, unless floor or other types of door stops are specified in Hardware Sets. Do not mount floor stops where they will impede traffic. Where floor or wall bumpers are not appropriate, provide overhead type stops and holders.

1. Manufacturers:

Rockwood Products (RO).

C. Overhead Door Stops and Holders: ANSI/BHMA A156.8, Grade 1 Certified Products Directory (CPD) listed overhead stops and holders to be surface or concealed types as indicated in Hardware Sets. Track, slide, arm and jamb bracket to be constructed of extruded bronze and shock absorber spring of heavy tempered steel. Provide non-handed design with mounting brackets as required for proper operation and function.

1. Manufacturers:

Rixson Door Controls (RF).

2.14 ARCHITECTURAL SEALS

A. General: Thresholds, weatherstripping, and gasket seals to be of type and design as specified below or in the Hardware Sets. Provide continuous weatherstrip gasketing on exterior doors and provide smoke, light, or sound gasketing on interior doors where indicated. At exterior applications provide non-corrosive fasteners and elsewhere where indicated.

B. Smoke Labeled Gasketing: Assemblies complying with NFPA 105 that are listed and labeled by a testing and inspecting agency acceptable to authorities having jurisdiction, for smoke control ratings indicated, based on testing according to UL 1784.

1. Provide smoke labeled perimeter gasketing at all smoke labeled openings.

- C. Fire Labeled Gasketing: Assemblies complying with NFPA 80 that are listed and labeled by a testing and inspecting agency acceptable to authorities having jurisdiction, for fire ratings indicated, based on testing according to UL-10C.
 - 1. Provide intumescent seals as indicated to meet UL10C Standard for Positive Pressure Fire Tests of Door Assemblies, and NPFA 252, Standard Methods of Fire Tests of Door Assemblies.
- D. Replaceable Seal Strips: Provide only those units where resilient or flexible seal strips are easily replaceable and readily available from stocks maintained by manufacturer.
- E. Manufacturers:
 - 1. Pemko Products (PE).

2.15 ELECTRONIC ACCESSORIES

- A. Request-to-Exit Motion Sensor: Request-to-Exit Sensors motion detectors specifically designed for detecting exiting through a door from the secure area to a non-secure area. Include built-in timers (up to 60 second adjustable timing), door monitor with sounder alert, internal vertical pointability coverage, 12VDC or 24VDC power and selectable relay trigger with fail safe/fail secure modes.
 - 1. Manufacturers:
 - Securitron (SU) - XMS Series.
- B. Door Position Switches: Door position magnetic reed contact switches specifically designed for use in commercial door applications. On recessed models the contact and magnetic housing snap-lock into a 1" diameter hole. Surface mounted models include wide gap distance design complete with armored flex cabling. Provide SPDT, N/O switches with optional Rare Earth Magnet installation on steel doors with flush top channels.
 - 1. Manufacturers:
 - Securitron (SU) - DPS Series.
- C. Switching Power Supplies: Provide power supplies with either single or dual voltage configurations at 12 or 24VDC. Power supplies shall have battery backup function with an integrated battery charging circuit and shall provide capability for power distribution, direct lock control and Fire Alarm Interface (FAI) through add on modules. Power supplies shall be expandable up to 16 individually protected outputs. Output modules shall provide individually protected, continuous outputs and/or individually protected, relay controlled outputs.
 - 1. Manufacturers:
 - Securitron (SU) - AQD Series.

2.16 FABRICATION

- A. Fasteners: Provide door hardware manufactured to comply with published templates generally prepared for machine, wood, and sheet metal screws. Provide screws according to manufacturers recognized installation standards for application intended.

2.17 FINISHES

- A. Standard: Designations used in the Hardware Sets and elsewhere indicate hardware finishes complying with ANSI/BHMA A156.18, including coordination with traditional U.S. finishes indicated by certain manufacturers for their products.
- B. Provide quality of finish, including thickness of plating or coating (if any), composition, hardness, and other qualities complying with manufacturer's standards, but in no case less than specified by referenced standards for the applicable units of hardware
- C. Protect mechanical finishes on exposed surfaces from damage by applying a strippable, temporary protective covering before shipping.

PART 3 - EXECUTION

3.1 EXAMINATION

- A. Examine scheduled openings, with Installer present, for compliance with requirements for installation tolerances, labeled fire door assembly construction, wall and floor construction, and other conditions affecting performance.
- B. Notify architect of any discrepancies or conflicts between the door schedule, door types, drawings and scheduled hardware. Proceed only after such discrepancies or conflicts have been resolved in writing.

3.2 PREPARATION

- A. Hollow Metal Doors and Frames: Comply with ANSI/DHI A115 series.
- B. Wood Doors: Comply with ANSI/DHI A115-W series.

3.3 INSTALLATION

- A. Install each item of mechanical and electromechanical hardware and access control equipment to comply with manufacturer's written instructions and according to specifications.
 - 1. Installers are to be trained and certified by the manufacturer on the proper installation and adjustment of fire, life safety, and security products including: hanging devices; locking devices; closing devices; and seals.

- B. Mounting Heights: Mount door hardware units at heights indicated in following applicable publications, unless specifically indicated or required to comply with governing regulations:
1. Standard Steel Doors and Frames: DHI's "Recommended Locations for Architectural Hardware for Standard Steel Doors and Frames."
 2. Wood Doors: DHI WDHS.3, "Recommended Locations for Architectural Hardware for Wood Flush Doors."
 3. Where indicated to comply with accessibility requirements, comply with ANSI A117.1 "Accessibility Guidelines for Buildings and Facilities."
 4. Provide blocking in drywall partitions where wall stops or other wall mounted hardware is located.
- C. Retrofitting: Install door hardware to comply with manufacturer's published templates and written instructions. Where cutting and fitting are required to install door hardware onto or into surfaces that are later to be painted or finished in another way, coordinate removal, storage, and reinstallation of surface protective trim units with finishing work specified in Division 9 Sections. Do not install surface-mounted items until finishes have been completed on substrates involved.
- D. Thresholds: Set thresholds for exterior and acoustical doors in full bed of sealant complying with requirements specified in Division 7 Section "Joint Sealants."
- E. Storage: Provide a secure lock up for hardware delivered to the project but not yet installed. Control the handling and installation of hardware items so that the completion of the work will not be delayed by hardware losses before and after installation.

3.4 FIELD QUALITY CONTROL

- A. Field Inspection (Punch Report): Reference Division 01 Sections "Closeout Procedures". Produce project punch report for each installed door opening indicating compliance with approved submittals and verification hardware is properly installed, operating and adjusted. Include list of items to be completed and corrected, indicating the reasons or deficiencies causing the Work to be incomplete or rejected.
1. Organization of List: Include separate Door Opening and Deficiencies and Corrective Action Lists organized by Mark, Opening Remarks and Comments, and related Opening Images and Video Recordings.
 2. Submit documentation of incomplete items in the following formats:
PDF electronic file.

3.5 ADJUSTING

- A. Initial Adjustment: Adjust and check each operating item of door hardware and each door to ensure proper operation or function of every unit. Replace units that cannot be adjusted to operate as intended. Adjust door control devices to compensate for final

operation of heating and ventilating equipment and to comply with referenced accessibility requirements.

3.6 CLEANING AND PROTECTION

- A. Protect all hardware stored on construction site in a covered and dry place. Protect exposed hardware installed on doors during the construction phase. Install any and all hardware at the latest possible time frame.
- B. Clean adjacent surfaces soiled by door hardware installation.
- C. Clean operating items as necessary to restore proper finish. Provide final protection and maintain conditions that ensure door hardware is without damage or deterioration at time of owner occupancy.

3.7 DEMONSTRATION

- A. Instruct Owner's maintenance personnel to adjust, operate, and maintain mechanical and electromechanical door hardware.

3.8 DOOR HARDWARE SETS

- A. The hardware sets represent the design intent and direction of the owner and architect. They are a guideline only and should not be considered a detailed hardware schedule. Discrepancies, conflicting hardware and missing items should be brought to the attention of the architect with corrections made prior to the bidding process. Omitted items not included in a hardware set should be scheduled with the appropriate additional hardware required for proper application and functionality.
 1. Quantities listed are for each pair of doors, or for each single door.
 2. The supplier is responsible for handing and sizing all products.
 3. Where multiple options for a piece of hardware are given in a single line item, the supplier shall provide the appropriate application for the opening.

Set: 1 – Exterior Entry

Doors: 105

3 Hinge	T4A3386 4-1/2" x 4-1/2"	US15	MK
1 Storeroom Lockset RU	CL3557 PZD x temporary core x SA118 x CMK		619
1 Permanent Core	CR8000 x MK	626	RU
1 Electric Strike	1006CS x 2004M x 24VDC	630	HS

1 ElectroLynx Harness	QC-C1500P		MK
<i>(Install between electric strike and junction box)</i>			
1 Closer	DC6200	689	RU
1 Kickplate	K1050 8" x 2" LDW 4BE CSK	US15	RO
1 Overhead Stop	1-X36 x 90 deg	619	RF
1 Threshold	171 A x DOW x MS & ES25		PE
1 Gasketing (Set)	S88 BL x DOW x DOH		PE
1 Door Bottom Seal	345 AV x DOW		PE
1 Drip Strip	346 C x DOW + 4"		PE
1 Card Reader	Furnished and installed by security contractor		OT
1 Door Position Switch	DPS-M-BK		SU
1 Motion Sensor	XMS x 24VDC		SU
1 Power Supply	AQD4		SU
1 Wiring Diagram	WD-SYSPK		RU

Push side card reader to be used by authorized persons to gain entry from the push side of the opening

Push side card reader to be used to activate the electric strike

Free egress always permitted by turning interior lever.

Set: 1.1 – Exterior Entry

Doors: 100

3 Hinge	T4A3386 4-1/2" x 4-1/2" NRP	US15	MK
1 Storeroom Lockset	CL3557 PZD x temporary core x SA118 x	619	
	RU		
	CMK		
1 Permanent Core	CR8000 x MK	626	RU
1 Electric Strike	1006CS x 2004M x 24VDC	630	HS
1 ElectroLynx Harness	QC-C1500P		MK
<i>(Install between electric strike and junction box)</i>			
1 Closer	DC6210 A13	689	RU
1 Kickplate	K1050 8" x 2" LDW 4BE CSK	US15	RO
1 Overhead Stop	9-X36 x 90 deg	619	RF
1 Threshold	171 A x DOW x MS & ES25		PE
1 Gasketing (Set)	316 AS x DOW x DOH		PE
1 Door Bottom Seal	345 AV x DOW		PE
1 Drip Strip	346 C x DOW + 4"		PE
1 Card Reader	Furnished and installed by security contractor		OT
1 Door Position Switch	DPS-M-BK		SU
1 Motion Sensor	XMS x 24VDC		SU
1 Power Supply	AQD4		SU

1 Wiring Diagram WD-SYSPK RU

Pull side card reader to be used by authorized persons to gain entry from the pull side of the opening

Pull side card reader to be used to activate the electric strike

Free egress always permitted from interior.

Set: 1.2 – Exterior Entry

Doors: 101

3 Hinge	T4A3386 5" x 4-1/2"	US15	MK
1 Storeroom Lockset	CL3557 PZD x temporary core x SA118 x		619
	RU		
	CMK		
1 Permanent Core	CR8000 x MK	626	RU
1 Electric Strike	1006CS x 2004M x 24VDC	630	HS
1 ElectroLynx Harness	QC-C1500P		MK
	<i>(Install between electric strike and junction box)</i>		
1 Closer	DC6200	689	RU
1 Kickplate	K1050 8" x 2" LDW 4BE CSK	US15	RO
1 Door Stop	481	US15	RO
1 Threshold	171 A x DOW x MS & ES25		PE
1 Gasketing (Set)	S88 BL x DOW x DOH		PE
1 Door Bottom Seal	345 AV x DOW		PE
1 Drip Strip	346 C x DOW + 4"		PE
1 Card Reader	Furnished and installed by security contractor		OT
1 Audio/Visual Intercom	Furnished and installed by security contractor		OT
1 Door Position Switch	DPS-M-BK		SU
1 Motion Sensor	XMS x 24VDC		SU
1 Power Supply	AQD4		SU
1 Wiring Diagram	WD-SYSPK		RU

Card reader to be used by authorized persons to gain entry from the exterior side of the opening

Card reader to be used to activate the electric strike

Pull side motion sensor to shunt the building security alarm

Free egress always permitted from interior by turning lever.

Set: 2 – Corridor/Public Toilet

Doors: 115

3 Hinge	T4A3786 4-1/2" x 4-1/2"	US15	MK
1 Privacy Set	CL3520 PZD x SA118	619	RU
1 Closer/Stop	DC6210 A11	689	RU
3 Silencer	608-RKW		RO

Set: 3 – Laundry/Coats (Passage)

Doors: 001, 006

3 Hinge	TA2714 4-1/2" x 4-1/2"	US15	MK
1 Passage Set	CL3510 PZD x SA118	619	RU
1 Wall Stop	402	US15	RO
1 Overhead Stop (for door 006 only)	10-X36 x 90 deg	619	RF
3 Silencer	608-RKW		RO

Set: 4 – Barn Door

Doors: 011, 106, 114, 117

1 Sliding Track Hardware System	DSG-FT-04SS x as required		PE
1 Push/Pull US32D	(2) RM2120 x 12" x Type 5HD mounting RO		

Set: 5 – Den/Vestibule

Doors: 102, 112

3 Hinge	T4A3786 4-1/2" x 4-1/2"	US15	MK
1 Storeroom Lockset RU	CL3557 PZD x temporary core x SA118 x CMK	619	
1 Permanent Core	CR8000 x MK	626	RU
1 Closer	DC5230	689	RU
1 Wall Stop	402	US15	RO
1 Gasketing (Set)	S88 BL x DOW x DOH		PE

Set: 5.1 – Storage

Doors: 205, 211

3 Hinge	TA2714 4-1/2" x 4-1/2" NRP	US15	MK
1 Storeroom Lockset RU	CL3557 PZD x temporary core x SA118 x CMK	619	
1 Permanent Core	CR8000 x MK	626	RU
1 Overhead Stop	10-X36 x 90 deg	619	RF
3 Silencer	608-RKW		RO

Set: 6 – Sensory

Doors: 007, 203

3 Hinge	TA2714 4-1/2" x 4-1/2"	US15	MK
---------	------------------------	------	----

DOOR HARDWARE

Section 087100, Project No.: 19296.01
Arlington County DHS Group Home

1 Classroom Lockset RU	CL3555 PZD x temporary core x SA118 x		619
	CMK		
1 Permanent Core	CR8000 x MK	626	RU
1 Wall Stop	402	US15	RO
3 Silencer	608-RKW		RO

Set: 7 – Bedroom/Sitting Rooms

Doors: 108, 109, 111, 206, 208, 210

3 Hinge	T4A3786 4-1/2" x 4-1/2"	US15	MK
1 Classroom Lockset RU	CL3555 PZD x temporary core x SA118 x		619
	CMK		
1 Permanent Core	CR8000 x MK	626	RU
1 Closer	DC5230	689	RU
1 Wall Stop	400	US15	RO
1 Door Stop	481	US15	RO
<i>(for door 210 only)</i>			
1 Gasketing (Set)	S88 BL x DOW x DOH		PE

Set: 8 – Private Bath

Doors: 003, 209

3 Hinge	TA2714 4-1/2" x 4-1/2"	US15	MK
1 Privacy Set	CL3520 PZD x SA118	619	RU
1 Wall Stop	400	US15	RO
3 Silencer	608-RKW		RO

Set: 8.1 – Private Bath

Doors: 107, 110a, 110b, 207

4 Hinge	TA2714 4-1/2" x 4-1/2"	US15	MK
1 Privacy Set	CL3520 PZD x SA118	619	RU
1 Overhead Stop	5-X36 x 90 deg	652	RF
3 Silencer	608-RKW		RO

Set: 9 – Utility

Doors: 014

3 Hinge	TA2714 4-1/2" x 4-1/2"	US15	MK
1 Storeroom Lockset RU	CL3557 PZD x temporary core x SA118 x		619

	CMK		
1 Permanent Core	CR8000 x MK	626	RU
1 Electric Strike	1006CS x 2004M x 24VDC	630	HS
1 ElectroLynx Harness	QC-C1500P		MK
	<i>(Install between electric strike and junction box)</i>		
1 Closer	DC6200	689	RU
1 Kickplate	K1050 8" x 2" LDW 4BE CSK	US15	RO
1 Wall Stop	402	US15	RO
3 Silencer	608-RKW		RO
1 Card Reader	Furnished and installed by security contractor		OT
1 Door Position Switch	DPS-W-BK		SU
1 Motion Sensor	XMS x 24VDC		SU
1 Power Supply	AQD4		SU
1 Wiring Diagram	WD-SYSPK		RU

Card reader to be used by authorized persons to gain entry from the push side of the opening

Card reader to be used to activate the electric strike

Pull side motion sensor to shunt the building security alarm

Free egress from pull side by turning lever

Set: 9.1 – Utility w/ Future Card Reader

Doors: 008, 015

3 Hinge	TA2714 4-1/2" x 4-1/2" NRP	US15	MK
1 Storeroom Lockset	CL3557 PZD x temporary core x SA118 x		619
	RU		
	CMK		
1 Permanent Core	CR8000 x MK	626	RU
1 Electric Strike	1006CS x 2004M x 24VDC	630	HS
1 ElectroLynx Harness	QC-C1500P		MK
	<i>(Install between electric strike and junction box)</i>		
1 Closer/Stop	DC6210 A11	689	RU
1 Closer	DC6200	689	RU
	<i>(for door 008 only)</i>		
1 Kickplate	K1050 8" x 2" LDW 4BE CSK	US15	RO
1 Wall Stop	402	US15	RO
	<i>(for door 008 only)</i>		
3 Silencer	608-RKW		RO
1 Door Position Switch	DPS-W-BK		SU
1 Wiring Diagram	WD-SYSPK		RU

The general contractor shall provide wire runs and hook-up for future card reader

Set: 10 – Exterior Utility

Doors: 010

DOOR HARDWARE

Section 087100, Project No.: 19296.01
Arlington County DHS Group Home

3 Hinge	TA2314 4-1/2" x 4-1/2" NRP	US15	MK
1 Storeroom Lockset RU	CL3557 PZD x temporary core x SA118 x		619
	CMK		
1 Permanent Core	CR8000 x MK	626	RU
1 Electric Strike	1006CS x 2004M x 24VDC	630	HS
1 ElectroLynx Harness <i>(Install between electric strike and junction box)</i>	QC-C1500P		MK
1 Latch Protector	321	US32D	RO
1 Closer	DC6210 A13	689	RU
1 Kickplate	K1050 8" x 2" LDW 4BE CSK	US15	RO
1 Overhead Stop	9-X36 x 90 deg	619	RF
1 Threshold	171 A x DOW x MS & ES25		PE
1 Gasketing (Set)	316 AS x DOW x DOH		PE
1 Door Bottom Seal	345 AV x DOW		PE
1 Drip Strip	346 C x DOW + 4"		PE
1 Card Reader	Furnished and installed by security contractor		OT
1 Motion Sensor	XMS x 24VDC		SU
1 Power Supply	AQD4		SU
1 Wiring Diagram	WD-SYSPK		RU

Card reader to be used by authorized persons to gain entry from the exterior side of the opening

Card reader to be used to activate the electric strike

Push side motion sensor to shunt the building security alarm

Free egress from interior at all times by turning lever.

Set: 11 – Shared Door (CR both sides)

Doors: 009

3 Hinge	T4A3786 4-1/2" x 4-1/2" NRP	US15	MK
1 Institutional Lockset RU	CL3332 PZD x temporary core x SA118 x		619
	CMK		
2 Permanent Core	CR8000 x MK	626	RU
1 Electric Strike	1006CS x 2004M x 24VDC	630	HS
1 ElectroLynx Harness <i>(Install between electric strike and junction box)</i>	QC-C1500P		MK
1 Closer/Stop	DC6210 A11	689	RU
1 Kickplate	K1050 8" x 2" LDW 4BE CSK	US15	RO
1 Gasketing (Set)	S88 BL x DOW x DOH		PE

Pull side card reader to be used by authorized persons to gain entry from the pull side of the opening

Pull side card reader to be used to activate the electric strike

Push side card reader to be used by authorized persons to gain entry from the push side of the opening

Push side card reader to be used to activate the electric strike

Entry only allowed by key or valid credential on both sides.

END OF SECTION 087100

SECTION 088000 - GLAZING

PART 1 - GENERAL

1.1 SUMMARY

- A. Section includes:
1. Glass for exterior doors, sidelites and transoms
 2. Glass for interior doors.
 3. Decorative glass.
 4. Obscure glass.
 5. Glazing sealants and accessories.

1.2 COORDINATION

- A. Coordinate glazing channel dimensions to provide necessary bite on glass, minimum edge and face clearances, and adequate sealant thicknesses, with reasonable tolerances.

1.3 ACTION SUBMITTALS

- A. Product Data: For each type of product.
- B. Glass Samples: For each type of glass product other than clear monolithic vision glass; 12 inches (300 mm) square.
- C. Glazing Schedule: List glass types and thicknesses for each size opening and location. Use same designations indicated on Drawings.

1.4 INFORMATIONAL SUBMITTALS

- A. Preconstruction adhesion and compatibility test report.

1.5 QUALITY ASSURANCE

- A. Sealant Testing Agency Qualifications: An independent testing agency qualified according to ASTM C 1021 to conduct the testing indicated.

1.6 PRECONSTRUCTION TESTING

- A. Preconstruction Adhesion and Compatibility Testing: Test each glass product, tape sealant, gasket, glazing accessory, and glass-framing member for adhesion to and compatibility with elastomeric glazing sealants.

1. Testing is not required if data are submitted based on previous testing of current sealant products and glazing materials matching those submitted.

1.7 WARRANTY

- A. Manufacturer's Special Warranty for Insulating Glass: Manufacturer agrees to replace insulating-glass units that deteriorate within specified warranty period. Deterioration of insulating glass is defined as failure of hermetic seal under normal use that is not attributed to glass breakage or to maintaining and cleaning insulating glass contrary to manufacturer's written instructions. Evidence of failure is the obstruction of vision by dust, moisture, or film on interior surfaces of glass.
 1. Warranty Period: 10 years from date of Substantial Completion.

PART 2 - PRODUCTS

2.1 PERFORMANCE REQUIREMENTS

- A. Structural Performance: Glazing shall withstand the following design loads within limits and under conditions indicated determined according to the International Building Code and ASTM E 1300.
 1. Design Wind Pressures: As indicated on Drawings.
 2. Differential Shading: Design glass to resist thermal stresses induced by differential shading within individual glass lites.
- B. Windborne-Debris-Impact Resistance: Exterior glazing shall pass ASTM E1886 missile-impact and cyclic-pressure tests in accordance with ASTM E1996 for Wind Zone 1 for basic protection. Test specimens shall be no smaller in width and length than glazing indicated for use on Project and shall be installed in same manner as glazing indicated for use on Project.
- C. Safety Glazing: Where safety glazing is indicated or required, provide glazing that complies with 16 CFR 1201, Category II.
- D. Thermal and Optical Performance Properties: Provide glass with performance properties specified, as indicated in manufacturer's published test data, based on procedures indicated below:
 1. U-Factors: Center-of-glazing values, according to NFRC 100 and based on LBL's WINDOW 5.2 computer program, expressed as Btu/sq. ft. x h x deg F (W/sq. m x K).
 2. Solar Heat-Gain Coefficient and Visible Transmittance: Center-of-glazing values, according to NFRC 200 and based on LBL's WINDOW 5.2 computer program.
 3. Visible Reflectance: Center-of-glazing values, according to NFRC 300.

2.2 GLASS PRODUCTS, GENERAL

- A. Glazing Publications: Comply with published recommendations of glass product manufacturers and organizations below unless more stringent requirements are indicated. See these publications for glazing terms not otherwise defined in this Section or in referenced standards.
 - 1. GANA Publications: "Glazing Manual."
 - 2. IGMA Publication for Insulating Glass: SIGMA TM-3000, "North American Glazing Guidelines for Sealed Insulating Glass Units for Commercial and Residential Use."
- B. Safety Glazing Labeling: Where safety glazing is indicated, permanently mark glazing with certification label of the SGCC or another certification agency acceptable to authorities having jurisdiction. Label shall indicate manufacturer's name, type of glass, thickness, and safety glazing standard with which glass complies.
- C. Insulating-Glass Certification Program: Permanently marked either on spacers or on at least one component lite of units with appropriate certification label of IGCC.
- D. Thickness: Where glass thickness is indicated, it is a minimum. Provide glass that complies with performance requirements and is not less than the thickness indicated.
- E. Strength: Where annealed float glass is indicated, provide annealed float glass, heat-strengthened float glass, or fully tempered float glass as needed to comply with "Performance Requirements" Article. Where heat-strengthened float glass is indicated, provide heat-strengthened float glass or fully tempered float glass as needed to comply with "Performance Requirements" Article. Where fully tempered float glass is indicated, provide fully tempered float glass.

2.3 GLASS PRODUCTS

- A. Clear Annealed Float Glass: ASTM C 1036, Type I, Class 1 (clear), Quality-Q3.
- B. Fully Tempered Float Glass: ASTM C 1048, Kind FT (fully tempered), Condition A (uncoated) unless otherwise indicated, Type I, Class 1 (clear), Quality-Q3.
- C. Decorative Glass: Danbury, fully tempered float glass. Pattern to be selected by Architect, refer to drawings for location. Provided by Pella or approved equivalent.
- D. Obscure Privacy Glass: Satin Etch, fully tempered float glass. Refer to drawings for location. Provided by Pella or approved equivalent.

2.4 INSULATING GLASS

- A. Insulating-Glass Units: Factory-assembled units consisting of sealed lites of glass separated by a dehydrated interspace, qualified according to ASTM E 2190.
 - 1. Sealing System: Dual seals.
 - 2. Perimeter Spacer: Aluminum with dark bronze, color anodic finish.

3. Muntins: 3/4 inch, contoured between glass, aluminum muntins with color to match frame finish.

2.5 GLAZING SEALANTS

A. General:

1. Compatibility: Compatible with one another and with other materials they contact, including glass products, seals of insulating-glass units, and glazing channel substrates, under conditions of service and application, as demonstrated by sealant manufacturer based on testing and field experience.
2. Suitability: Comply with sealant and glass manufacturers' written instructions for selecting glazing sealants suitable for applications indicated and for conditions existing at time of installation.
3. Colors of Exposed Glazing Sealants: Dark bronze as selected by Architect from manufacturer's full range.

- B. Glazing Sealant: Neutral-curing silicone glazing sealant complying with ASTM C 920, Type S, Grade NS, Class 100/50, Use NT.

- C. VOC Content: All glazing sealants applied inside the weatherproofing system of the building shall have a VOC content of 250 g/L or less when calculated according to 40 CFR 59, Subpart D (EPA Method 24).

2.6 GLAZING TAPES

- A. Back-Bedding Mastic Glazing Tapes: Preformed, butyl-based, 100 percent solids elastomeric tape; nonstaining and nonmigrating in contact with nonporous surfaces; with or without spacer rod as recommended in writing by tape and glass manufacturers for application indicated; and complying with ASTM C 1281 and AAMA 800 for products indicated below:

1. AAMA 806.3 tape, for glazing applications in which tape is subject to continuous pressure.
2. AAMA 807.3 tape, for glazing applications in which tape is not subject to continuous pressure.

- B. Expanded Cellular Glazing Tapes: Closed-cell, PVC foam tapes; factory coated with adhesive on both surfaces; and complying with AAMA 800 for the following types:

1. AAMA 810.1, Type 1, for glazing applications in which tape acts as the primary sealant.
2. AAMA 810.1, Type 2, for glazing applications in which tape is used in combination with a full bead of liquid sealant.

2.7 MISCELLANEOUS GLAZING MATERIALS

- A. Cleaners, Primers, and Sealers: Types recommended by sealant or gasket manufacturer.

- B. Setting Blocks: Elastomeric material with a Shore, Type A durometer hardness of 85, plus or minus 5.
- C. Spacers: Elastomeric blocks or continuous extrusions of hardness required by glass manufacturer to maintain glass lites in place for installation indicated.
- D. Edge Blocks: Elastomeric material of hardness needed to limit glass lateral movement (side walking).
- E. Cylindrical Glazing Sealant Backing: ASTM C 1330, Type O (open-cell material), of size and density to control glazing sealant depth and otherwise produce optimum glazing sealant performance.

PART 3 - EXECUTION

3.1 GLAZING, GENERAL

- A. Comply with combined written instructions of manufacturers of glass, sealants, gaskets, and other glazing materials, unless more stringent requirements are indicated, including those in referenced glazing publications.
- B. Protect glass edges from damage during handling and installation. Remove damaged glass from Project site and legally dispose of off Project site. Damaged glass includes glass with edge damage or other imperfections that, when installed, could weaken glass, impair performance, or impair appearance.
- C. Decorative Film Overlay: Apply squarely aligned to glass edges and framing members, uniformly smooth, and free from tears, air bubbles, wrinkles, and rough edges, in pattern indicated on Drawings to the back face of clean glass, according to manufacturer's written instructions, including surface preparation and application temperature limitations.
- D. Apply primers to joint surfaces where required for adhesion of sealants, as determined by preconstruction testing.
- E. Install setting blocks in sill rabbets, sized and located to comply with referenced glazing publications, unless otherwise required by glass manufacturer. Set blocks in thin course of compatible sealant suitable for heel bead.
- F. Do not exceed edge pressures stipulated by glass manufacturers for installing glass lites.
- G. Provide spacers for glass lites where length plus width is larger than 50 inches (1270 mm).
- H. Provide edge blocking where indicated or needed to prevent glass lites from moving sideways in glazing channel, as recommended in writing by glass manufacturer and according to requirements in referenced glazing publications.

3.2 TAPE GLAZING

- A. Position tapes on fixed stops so that, when compressed by glass, their exposed edges are flush with or protrude slightly above sightline of stops.
- B. Install tapes continuously, but not necessarily in one continuous length. Do not stretch tapes to make them fit opening.
- C. Cover vertical framing joints by applying tapes to heads and sills first, then to jambs. Cover horizontal framing joints by applying tapes to jambs, then to heads and sills.
- D. Place joints in tapes at corners of opening with adjoining lengths butted together, not lapped. Seal joints in tapes with compatible sealant approved by tape manufacturer.
- E. Apply heel bead of elastomeric sealant.
- F. Center glass lites in openings on setting blocks, and press firmly against tape by inserting dense compression gaskets formed and installed to lock in place against faces of removable stops. Start gasket applications at corners and work toward centers of openings.
- G. Apply cap bead of elastomeric sealant over exposed edge of tape.

3.3 GASKET GLAZING (DRY)

- A. Cut compression gaskets to lengths recommended by gasket manufacturer to fit openings exactly, with allowance for stretch during installation.
- B. Insert soft compression gasket between glass and frame or fixed stop so it is securely in place with joints miter cut and bonded together at corners.
- C. Installation with Drive-in Wedge Gaskets: Center glass lites in openings on setting blocks, and press firmly against soft compression gasket by inserting dense compression gaskets formed and installed to lock in place against faces of removable stops. Start gasket applications at corners and work toward centers of openings. Compress gaskets to produce a weathertight seal without developing bending stresses in glass. Seal gasket joints with sealant recommended by gasket manufacturer.
- D. Installation with Pressure-Glazing Stops: Center glass lites in openings on setting blocks, and press firmly against soft compression gasket. Install dense compression gaskets and pressure-glazing stops, applying pressure uniformly to compression gaskets. Compress gaskets to produce a weathertight seal without developing bending stresses in glass. Seal gasket joints with sealant recommended by gasket manufacturer.
- E. Install gaskets so they protrude past face of glazing stops.

3.4 SEALANT GLAZING (WET)

- A. Install continuous spacers, or spacers combined with cylindrical sealant backing, between glass lites and glazing stops to maintain glass face clearances and to prevent sealant from extruding into glass channel and blocking weep systems until sealants cure. Secure spacers or spacers and backings in place and in position to control depth of installed sealant relative to edge clearance for optimum sealant performance.
- B. Force sealants into glazing channels to eliminate voids and to ensure complete wetting or bond of sealant to glass and channel surfaces.
- C. Tool exposed surfaces of sealants to provide a substantial wash away from glass.

3.5 CLEANING AND PROTECTION

- A. Immediately after installation remove nonpermanent labels and clean surfaces.
- B. Protect glass from contact with contaminating substances resulting from construction operations. Examine glass surfaces adjacent to or below exterior concrete and other masonry surfaces at frequent intervals during construction, but not less than once a month, for buildup of dirt, scum, alkaline deposits, or stains.
 - 1. If, despite such protection, contaminating substances do come into contact with glass, remove substances immediately as recommended in writing by glass manufacturer. Remove and replace glass that cannot be cleaned without damage to coatings.
- C. Remove and replace glass that is damaged during construction period.

3.6 MONOLITHIC GLASS SCHEDULE

- A. Glass Type: Clear fully tempered float glass.
 - 1. Minimum Thickness: 6 mm.
 - 2. Safety glazing required.

3.7 INSULATING GLASS SCHEDULE

- A. Glass Type: Low-E-coated, clear insulating glass for exterior door applications and not provided by exterior window manufacturer.
 - 1. Basis-of-Design Product: PPG, Solarban 70XL, "Clear".
 - 2. Overall Unit Thickness: Not less than 1 inch (25 mm).
 - 3. Minimum Thickness of Each Glass Lite: 6 mm.
 - 4. Outdoor Lite: Fully tempered float glass, clear or decorative.
 - 5. Interspace Content: Argon.
 - 6. Indoor Lite: Fully tempered float glass, clear or obscure.
 - 7. Low-E Coating: Sputtered on second or third surface.

8. Winter Nighttime U-Factor: 0.28 maximum.
9. Summer Daytime U-Factor: 0.26 maximum.
10. Visible Light Transmittance: 64%.
11. Total Solar Energy Transmittance: 25%.
12. Safety glazing required.

END OF SECTION 088000

SECTION 088300 - MIRRORS

PART 1 - GENERAL

1.1 SUMMARY

A. Section includes the following types of silvered flat glass mirrors:

1. Annealed monolithic glass mirrors.
2. Tempered monolithic glass mirrors.

1.2 ACTION SUBMITTALS

- A. Product Data: For each type of product indicated.
- B. Shop Drawings: Include mirror elevations, edge details, mirror hardware, and attachments to other work.

1.3 INFORMATIONAL SUBMITTALS

- A. Warranty: Sample of special warranty.

1.4 CLOSEOUT SUBMITTALS

- A. Maintenance data.

1.5 QUALITY ASSURANCE

- A. Glazing Publications: Comply with GANA's "Glazing Manual" and "Mirrors, Handle with Extreme Care: Tips for the Professional on the Care and Handling of Mirrors."
- B. Preconstruction Mirror Mastic Compatibility Test: Submit mirror mastic products to mirror manufacturer for testing to determine compatibility of mastic with mirror backing and substrates on which mirrors are installed.

1.6 WARRANTY

- A. Special Warranty: Manufacturer's standard form in which mirror manufacturer agrees to replace mirrors that deteriorate within specified warranty period. Deterioration of mirrors is defined as defects developed from normal use that are not attributed to mirror breakage or to maintaining and cleaning mirrors contrary to manufacturer's written instructions. Defects include discoloration, black spots, and clouding of the silver film.

1. Warranty Period: Five years from date of Substantial Completion.

PART 2 - PRODUCTS

2.1 SILVERED FLAT GLASS MIRRORS

- A. Glass Mirrors, General: ASTM C 1503; manufactured using copper-free, low-lead mirror coating process.
 1. Manufacturers: Subject to compliance with requirements, provide products by one of the following or approved equivalent:
 - a. Avalon Glass and Mirror Company.
 - b. Binswanger Mirror; a division of Vitro America, Inc.
 - c. Guardian Industries.
 - d. Independent Mirror Industries, Inc.
 - e. Lenoir Mirror Company.
 - f. Maran-Wurzell Glass & Mirror.
 - g. National Glass Industries.
 - h. Stroupe Mirror Co., Inc.
 - i. Sunshine Mirror; Westshore Glass Corp.
 - j. Virginia Mirror Company, Inc.
 - k. Walker Glass Co., Ltd.
- B. Annealed Monolithic Glass Mirrors: Mirror Select Quality, clear.
 1. Nominal Thickness: 6.0 mm.
- C. Tempered Glass Mirrors: Mirror Glazing Quality for blemish requirements and complying with ASTM C 1048 for Kind FT, Condition A, tempered float glass before silver coating is applied.
 1. Nominal Thickness: 9.0 mm.
- D. Safety Glazing Products: For film-backed, tempered mirrors, provide products that comply with 16 CFR 1201, Category II.
- E. Refer to Interior Elevations on drawings for custom shaped mirrors.

2.2 MISCELLANEOUS MATERIALS

- A. Setting Blocks: Elastomeric material with a Shore, Type A durometer hardness of 85, plus or minus 5.
- B. Edge Sealer: Approved by mirror manufacturer.

- C. Mirror Mastic: An adhesive setting compound, asbestos-free, produced specifically for setting mirrors.
 - 1. Adhesive shall have a VOC content of not more than 70 g/L when calculated according to 40 CFR 59, Subpart D (EPA Method 24).
- D. Film Backing for Safety Mirrors: Film backing and pressure-sensitive adhesive; both compatible with mirror backing paint as certified by mirror manufacturer.

2.3 MIRROR HARDWARE

- A. Fasteners: Provide concealed anchorage unless noted otherwise. Where fasteners are exposed, fabricate from same metal and alloy as metal and matching it in finished color and texture as adjacent metals.
- B. Anchors and Inserts: Provide devices as required for concealed mirror hardware installation.

2.4 FABRICATION

- A. Cutouts: Fabricate cutouts for notches and holes in mirrors without marring visible surfaces. Locate and size cutouts so they fit closely around penetrations in mirrors.
- B. Mirror Edge Treatment: Flat, polished edges. Seal edges of mirrors with edge sealer.
- C. Film-Backed Safety Mirrors: Apply film backing with adhesive coating over mirror backing paint as recommended in writing by film-backing manufacturer.

PART 3 - EXECUTION

3.1 INSTALLATION

- A. Examine substrates, over which mirrors are to be mounted, with Installer present, for compliance with installation tolerances, substrate preparation, and other conditions affecting performance of the Work.
 - 1. Verify compatibility with and suitability of substrates, including compatibility of mirror mastic with existing finishes or primers.
 - 2. Proceed with installation only after unsatisfactory conditions have been corrected and surfaces are dry.
- B. Comply with mastic manufacturer's written installation instructions for preparation of substrates, including coating substrates with mastic manufacturer's special bond coating where applicable.

- C. General: Install mirrors to comply with mirror manufacturer's written instructions and with referenced GANA publications. Mount mirrors accurately in place in a manner that avoids distorting reflected images.
- D. Wall-Mounted Mirrors: Install mirrors with mirror hardware. Attach mirror hardware securely to mounting surfaces with mechanical fasteners installed with anchors or inserts as applicable. Install fasteners so heads do not impose point loads on backs of mirrors
- E. Protect mirrors from breakage and contaminating substances resulting from construction operations.
- F. Do not permit edges of mirrors to be exposed to standing water.
- G. Maintain environmental conditions that will prevent mirrors from being exposed to moisture from condensation or other sources for continuous periods of time.
- H. Wash exposed surface of mirrors not more than four days before date scheduled for inspections that establish date of Substantial Completion. Wash mirrors as recommended in writing by mirror manufacturer.

END OF SECTION 088300

SECTION 092216 - NON-STRUCTURAL METAL FRAMING

PART 1 - GENERAL

1.1 SUMMARY

A. Section Includes:

1. Non-load-bearing steel systems for interior partitions.
2. Suspension systems for interior ceilings.

1.2 ACTION SUBMITTALS

A. Product Data: For each type of product.

1.3 INFORMATIONAL SUBMITTALS

A. Product Certificates: For each type of code-compliance certification for studs and tracks.

1.4 QUALITY ASSURANCE

A. Code-Compliance Certification of Studs and Tracks: Provide documentation that framing members are certified according to the product-certification program of the Certified Steel Stud Association, the Steel Framing Industry Association or the Steel Stud Manufacturers Association.

PART 2 - PRODUCTS

2.1 PERFORMANCE REQUIREMENTS

A. STC-Rated Assemblies: For STC-rated assemblies, provide materials and construction identical to those tested in assembly indicated on Drawings, according to ASTM E 90 and classified according to ASTM E 413 by an independent testing agency.

2.2 FRAMING SYSTEMS

A. Framing Members, General: Comply with ASTM C 754 for conditions indicated.

1. Steel Sheet Components: Comply with ASTM C 645 requirements for metal unless otherwise indicated.
2. Protective Coating: Coating with equivalent corrosion resistance of ASTM A 653/A 653M, G40 (Z120), hot-dip galvanized unless otherwise indicated.

- B. Flat Strap and Backing Plate: Minimum 4-inch wide steel sheet for blocking and bracing in length and width indicated.
 - 1. Minimum Base-Metal Thickness: Not less than 0.0329 inch (0.836 mm).
- C. Cold-Rolled Channel Bridging: Steel, 0.0538-inch (1.367-mm) minimum base-metal thickness, with minimum 1/2-inch- (13-mm-) wide flanges.
 - 1. Depth: Not less than 1-1/2 inches (38 mm).
 - 2. Clip Angle: Not less than 1-1/2 by 1-1/2 inches (38 by 38 mm), 0.068-inch- (1.72-mm-) thick, galvanized steel.
- D. Resilient Furring Channels: 1/2-inch- (13-mm-) deep, steel sheet members designed to reduce sound transmission.
 - 1. Manufacturer: Clark Dietrich, RC-1 Pro Plus.
 - 2. Configuration: Single leg (Asymmetrical).
 - 3. Minimum Base-Metal Thickness: 0.0232 inch.
 - 4. Flange Width: 1-1/2 inch (38 mm).

2.3 DRYWALL CEILING SUSPENSION SYSTEM

- A. Manufacturers: Subject to compliance with requirements, provide products by the following:
 - 1. Armstrong World Industries, Inc.
- B. AP-1: Drywall suspension system with all main beams and cross tees of commercial quality hot-dipped galvanized steel.
 - 1. Main beam: manufactured main beam- 1-1/2" knurled face with ScrewStop™ reverse hem by 1-11/16 inches high. Drywall Main Beams are factory punched with cross tee routs, hanger wire holes, and SuperLock™ main beam clip for a secure connection and fast accurate alignment. Both ShortSpan and Drywall Main Beams are Heavy-duty performance per ASTM C635.
 - 2. Cross Tees: manufactured cross tee- 1-1/2" knurled face with ScrewStop™ reverse hem by 1-1/2 inches high with factory punched cross tee routs and hanger wire holes and XL stake on clip for a secure connection.
 - 3. Wall molding: 12ft Knurled Angle Molding 1-1/4" Face.
- C. QuikStix Soffits DGS: Shall be double web steel construction (minimum 0.0179 inch prior to protective coating, ASTM C645), Tees designed for creating soffits; 1-1/2 inch web height. 1-1/2 inch flange, flattened bulb, bending crimp, knockouts and alignment holes to facilitate creating 15, 30, 45, 60 and 90 degree angles; available with G40 or G90 hot dipped galvanization.

2.4 SUSPENSION SYSTEMS

- A. Tie Wire: ASTM A 641/A 641M, Class 1 zinc coating, soft temper, 0.062-inch- (1.59-mm-) diameter wire, or double strand of 0.048-inch- (1.21-mm-) diameter wire.

- B. Acoustic Wire Hangers: Rubber Element washer device with wire loops for sound reduction in suspended ceiling system.
 - 1. Manufactured by VibraSystems Inc., www.vabrasystems.com; Model # WH-100 or approved equivalent.
 - 2. Rated Load Capacity: 200 lbs.
 - 3. Deflection: 0.20 inches at rated load.
- C. Wire Hangers: ASTM A 641/A 641M, Class 1 zinc coating, soft temper, 0.16 inch (4.12 mm) in diameter.
- D. Carrying Channels (Main Runners): Cold-rolled, commercial-steel sheet with a base-metal thickness of 0.0538 inch (1.367 mm) and minimum 1/2-inch- (13-mm-) wide flanges.
 - 1. Depth: Not less than 1-1/2 inches (38 mm).
 - 2. Hat-Shaped, Rigid Furring Channels: ASTM C 645, 7/8 inch (22 mm) deep.
 - a. Minimum Base-Metal Thickness: 0.0179 inch (0.455 mm).

2.5 AUXILIARY MATERIALS

- A. General: Provide auxiliary materials that comply with referenced installation standards.
 - 1. Fasteners for Steel Framing: Of type, material, size, corrosion resistance, holding power, and other properties required to fasten steel members to substrates.
- B. Isolation Strip at Exterior Walls: Provide one of the following:
 - 1. Asphalt-Saturated Organic Felt: ASTM D 226/D 226M, Type I (No. 15 asphalt felt), nonperforated.
 - 2. Foam Gasket: Adhesive-backed, closed-cell vinyl foam strips that allow fastener penetration without foam displacement, 1/8 inch (3.2 mm) thick, in width to suit steel stud size.

PART 3 - EXECUTION

3.1 INSTALLATION, GENERAL

- A. Installation Standard: ASTM C 754.
 - 1. Gypsum Board Assemblies: Also comply with requirements in ASTM C 840 that apply to framing installation.
- B. Install framing and accessories plumb, square, and true to line, with connections securely fastened.

- C. Install supplementary framing, and blocking to support fixtures, equipment services, heavy trim, grab bars, toilet accessories, furnishings, or similar construction.
- D. Install bracing at terminations in assemblies.
- E. Do not bridge building control and expansion joints with non-load-bearing steel framing members. Frame both sides of joints independently.

3.2 INSTALLING FRAMED ASSEMBLIES

- A. Install framing system components according to spacings indicated, but not greater than spacings required by referenced installation standards for assembly types.
 - 1. Sound-Rated Partitions: Install framing to comply with sound-rated assembly indicated. Resilient furring channels are to be installed in accordance with manufacturer's written instructions and to meet the sound transmission requirements of the specified assemblies.
- B. Direct Furring:
 - 1. Attach to concrete or masonry with stub nails, screws designed for masonry attachment, or powder-driven fasteners spaced 24 inches (610 mm) o.c.
- C. Installation Tolerance: Install each framing member so fastening surfaces vary not more than 1/8 inch (3 mm) from the plane formed by faces of adjacent framing.

3.3 INSTALLING CEILING SUSPENSION SYSTEMS

- A. Install suspension system components according to spacings indicated, but not greater than spacings required by referenced installation standards for assembly types.
- B. Isolate suspension systems from building structure where they abut or are penetrated by building structure to prevent transfer of loading imposed by structural movement.
- C. Suspend hangers from building structure as follows:
 - 1. Install hangers plumb and free from contact with insulation or other objects within ceiling plenum that are not part of supporting structural or suspension system.
 - a. Splay hangers only where required to miss obstructions and offset resulting horizontal forces by bracing, countersplaying, or other equally effective means.
 - 2. Where width of ducts and other construction within ceiling plenum produces hanger spacings that interfere with locations of hangers required to support standard suspension system members, install supplemental suspension members and hangers in the form of trapezes or equivalent devices.
 - a. Size supplemental suspension members and hangers to support ceiling loads within performance limits established by referenced installation standards.

3. Wire Hangers: Secure by looping and wire tying, either directly to structures or to inserts, eye screws, or other devices and fasteners that are secure and appropriate for substrate, and in a manner that will not cause hangers to deteriorate or otherwise fail.
 4. Install acoustic wire hanger devices within the length of each wire hanger supporting suspended ceiling grid.
 5. Do not connect or suspend steel framing from ducts, pipes, or conduit.
- D. Seismic Bracing: Sway-brace suspension systems with hangers used for support where required by jurisdiction authorities.
- E. Installation Tolerances: Install suspension systems that are level to within 1/8 inch in 12 feet (3 mm in 3.6 m) measured lengthwise on each member that will receive finishes and transversely between parallel members that will receive finishes.

END OF SECTION 092216

THIS PAGE INTENSIONALLY LEFT BLANK

SECTION 092900 - GYPSUM BOARD

PART 1 - GENERAL

1.1 SUMMARY

A. Section Includes:

1. Interior gypsum board.
2. Tile backing panels.

1.2 ACTION SUBMITTALS

- A. Product Data: For each type of product and trim.

1.3 QUALITY ASSURANCE

- A. Mockups: Build mockups to demonstrate aesthetic effects and set quality standards for materials and execution.

1. Build mockup of Level 4 finish, interior gypsum board installation.
2. Mockups will be not less than 80 square feet in size
3. Mock-up shall be approved by Architect and Owner and may become part of the completed work.

1.4 DELIVERY, STORAGE AND HANDLING

- A. Store materials inside under cover and keep them dry and protected against weather, condensation, direct sunlight, construction traffic, and other potential causes of damage. Stack panels flat and supported on risers on a flat platform to prevent sagging.

1.5 FIELD CONDITIONS

- A. Environmental Limitations: Comply with ASTM C 840 requirements or gypsum board manufacturer's written recommendations, whichever are more stringent.

- B. Do not install paper-faced gypsum panels until installation areas are enclosed and conditioned.

- C. Do not install panels that are wet, those that are moisture damaged, and those that are mold damaged.

1. Indications that panels are wet or moisture damaged include, but are not limited to, discoloration, sagging, or irregular shape.

2. Indications that panels are mold damaged include, but are not limited to, fuzzy or splotchy surface contamination and discoloration.

PART 2 - PRODUCTS

2.1 PERFORMANCE REQUIREMENTS

- A. STC-Rated Assemblies: For STC-rated assemblies, provide materials and construction identical to those tested in assembly indicated according to ASTM E 90 and classified according to ASTM E 413 by an independent testing agency.

2.2 INTERIOR GYPSUM BOARD

- A. Manufacturers: Subject to compliance with requirements, provide products by one of the following:
 1. CertainTeed Corp.
 2. Georgia-Pacific Gypsum LLC.
 3. National Gypsum Company.
 4. USG Corporation.
- B. Gypsum Ceiling Board: ASTM C 1396/C 1396M.
 1. Thickness: 5/8 inch (15.9 mm).
 2. Long Edges: Tapered.
- C. Impact-Resistant Gypsum Board: ASTM C 1396/C 1396M gypsum board, tested according to ASTM C 1629/C 1629M. Standard for project.
 1. Core: 5/8 inch (15.9 mm), Type X.
 2. Surface Abrasion: ASTM C 1629/C 1629M, meets or exceeds Level 2 requirements.
 3. Indentation: ASTM C 1629/C 1629M, meets or exceeds Level 1 requirements.
 4. Soft-Body Impact: ASTM C 1629/C 1629M, meets or exceeds Level 1 requirements.
 5. Hard-Body Impact: ASTM C 1629/C 1629M, meets or exceeds Level 1 requirements according to test in Annex A1.
 6. Long Edges: Tapered.
 7. Mold Resistance: ASTM D 3273, score of 10 as rated according to ASTM D 3274.

2.3 TILE BACKING PANELS

- A. Glass-Mat, Water-Resistant Backing Board: ASTM C 1178/C 1178M, with manufacturer's standard edges.
 1. Products: Subject to compliance with requirements, provide one of the following:

- a. CertainTeed Corp.; GlasRoc Tile Backer.
 - b. Georgia-Pacific Gypsum LLC; DensShield Tile Backer.
2. Core: 5/8 inch (15.9 mm), Type X where required for fire-rated partitions.
 3. Mold Resistance: ASTM D 3273, score of 10 as rated according to ASTM D 3274.

2.4 TRIM ACCESSORIES

- A. Interior Trim: ASTM C 1047.
 1. Material: Galvanized or aluminum-coated steel sheet or rolled zinc.
- B. Aluminum Trim: ASTM B 221 (ASTM B 221M), Alloy 6063-T5.

2.5 JOINT TREATMENT MATERIALS

- A. General: Comply with ASTM C 475/C 475M.
- B. Joint Tape:
 1. Interior Gypsum Board: Paper.
 2. Glass-Mat Backing Board: 10-by-10 glass mesh.
 3. Tile Backing Panels: As recommended by panel manufacturer.
- C. Joint Compound for Interior Gypsum Board: For each coat use formulation that is compatible with other compounds applied on previous or for successive coats.

2.6 AUXILIARY MATERIALS

- A. General: Provide auxiliary materials that comply with referenced installation standards and manufacturer's written instructions.
- B. Laminating Adhesive: Adhesive or joint compound recommended for directly adhering gypsum panels to continuous substrate.
 1. Laminating adhesive shall have a VOC content of 50 g/L or less).
- C. Steel Drill Screws: ASTM C 1002 unless otherwise indicated.
 1. Use screws complying with ASTM C 954 for fastening panels to steel members from 0.033 to 0.112 inch (0.84 to 2.84 mm) thick.
 2. For fastening cementitious backer units, use screws of type and size recommended by panel manufacturer.
- D. Sound Attenuation Blankets: ASTM C 665, Type I (blankets without membrane facing) produced by combining thermosetting resins with mineral fibers manufactured from glass, slag wool, or rock wool.

- E. Acoustical Joint Sealant: As specified in Section 079200 "Joint Sealants."
- F. Thermal Insulation: As specified in Section 072100 "Thermal Insulation."
- G. Vapor Retarders: As specified in Section 072600 "Vapor Retarder."

PART 3 - EXECUTION

3.1 APPLYING AND FINISHING PANELS

- A. Comply with ASTM C 840.
- B. Examine panels before installation. Reject panels that are wet, moisture damaged, and mold damaged.
- C. Isolate perimeter of gypsum board applied to non-load-bearing partitions at structural abutments, except floors. Provide 1/4- to 1/2-inch- (6.4- to 12.7-mm-) wide spaces at these locations and trim edges with edge trim where edges of panels are exposed. Seal joints between edges and abutting structural surfaces with acoustical sealant.
- D. Install trim with back flanges intended for fasteners, attach to framing with same fasteners used for panels. Otherwise, attach trim according to manufacturer's written instructions.
 - 1. Aluminum Trim: Install in locations indicated on Drawings and where required to frame and provide a finished decorative edge around wall mounted, recessed specialties.
 - 2. Control Joints: Install control joints according to ASTM C 840 and in specific locations approved by Architect for visual effect.
- E. Prefill open joints, rounded or beveled edges, and damaged surface areas.
- F. Apply joint tape over gypsum board joints, except for trim products specifically indicated as not intended to receive tape.
- G. Gypsum Board Finish Levels: Finish panels to levels indicated below and according to ASTM C 840:
 - 1. Level 1: Ceiling plenum areas, concealed areas, and where indicated.
 - 2. Level 2: Panels that are substrate for tile.
 - 3. Level 4: At panel surfaces that will be exposed to view unless otherwise indicated.
 - a. Primer and its application to surfaces are specified in Section 099123 "Interior Painting."
 - 4. Level 5: Where Wall Coverings are specified to be applied on gypsum board and where indicated on Drawings and Finish Notes.
 - a. Primer and its application to surfaces are specified in Section 099123 "Interior Painting."

3.2 PROTECTION

- A. Protect adjacent surfaces from drywall compound and texture finishes and promptly remove from floors and other non-drywall surfaces. Repair surfaces stained, marred, or otherwise damaged during drywall application.
- B. Remove and replace all gypsum board panels that are wet, moisture damaged or mold damaged.

END OF SECTION 092900

THIS PAGE INTENSIONALLY LEFT BLANK

SECTION 093013 - CERAMIC TILING

PART 1 - GENERAL

1.1 SUMMARY

A. Section Includes:

1. Porcelain floor and wainscot tile.
2. Porcelain mosaic floor tile.
3. Ceramic wall tile.
4. Waterproof building panel and curb.
5. Waterproof membrane.
6. Crack isolation membrane for thinset applications.
7. Metal edge strips.

1.2 ACTION SUBMITTALS

- A. Product Data: For each type of product.
- B. Shop Drawings: Show locations of each type of tile and tile pattern. Show widths, details, and locations of expansion, contraction, control, and isolation joints in tile substrates and finished tile surfaces.
- C. Samples: Provide for type and composition of tile and for each color and finish required.

1.3 INFORMATIONAL SUBMITTALS

- A. Qualification Data: For Installer.

1.4 QUALITY ASSURANCE

A. Installer Qualifications:

1. Installer is a five-star member of the National Tile Contractors Association or a Trowel of Excellence member of the Tile Contractors' Association of America.
2. Installer's supervisor for Project holds the International Masonry Institute's Foreman Certification.
3. Installer employs Ceramic Tile Education Foundation Certified Installer.

- B. Mockups: Build mockups to verify selections made under Sample submittals and to demonstrate aesthetic effects and set quality standards for materials and execution.

1. Build mockup of each type floor tile installation.
2. Build mockup of wall tile installation.

3. Mock-ups shall be approved by Architect and Owner. Subject to compliance with requirements, approved mockups may become part of the completed Work if undisturbed at time of Substantial Completion.

1.5 DELIVERY, STORAGE, AND HANDLING

- A. Deliver and store packaged materials in original containers with seals unbroken and labels intact until time of use. Comply with requirements in ANSI A137.1 for labeling tile packages.
- B. Store tile and cementitious materials on elevated platforms, under cover, and in a dry location.
- C. Store aggregates where grading and other required characteristics can be maintained and contamination can be avoided.
- D. Store liquid materials in unopened containers and protected from freezing.

1.6 FIELD CONDITIONS

- A. Environmental Limitations: Do not install tile until construction in spaces is complete and ambient temperature and humidity conditions are maintained at the levels indicated in referenced standards and manufacturer's written instructions.

PART 2 - PRODUCTS

2.1 PRODUCTS, GENERAL

- A. ANSI Ceramic Tile Standard: Provide Standard-grade tile that complies with ANSI A137.1 for types, compositions, and other characteristics indicated.
- B. ANSI Standards for Tile Installation Materials: Provide materials complying with ANSI A108.02, ANSI standards referenced in other Part 2 articles, ANSI standards referenced by TCNA installation methods specified in tile installation schedules, and other requirements specified.

2.2 TILE PRODUCTS

- A. Porcelain Tile (T-1, T-2, WT-4 and WT-5): Matte finish for interior floor, wainscot and trim use.
 1. Products: Refer to Refer to Finish Material Schedule, Sheet #F100.
 2. Grout Colors: Refer to Refer to Finish Material Schedule, Sheet #F100.
 3. Dynamic Coefficient of Friction: Not less than 0.40 for T-1. Not less than 0.42 for T-2.
 4. Bullnose Trim for Wainscot: Refer to Refer to Finish Material Schedule, Sheet #F100
 5. Trim Units: Coordinated with sizes and coursing of adjoining flat tile where applicable and matching characteristics of adjoining floor and wall tile.

- B. Porcelain Mosaic Tile (T-3): Matte finish for interior shower floor use.
1. Products: Refer to Refer to Finish Material Schedule, Sheet #F100.
 2. Grout Colors: Refer to Refer to Finish Material Schedule, Sheet #F100.
 3. Dynamic Coefficient of Friction: Not less than 0.42.
 4. Size: 2 inch by 2 inch tile, mesh mounted.
 5. Trim Units: Coordinated with sizes and coursing of adjoining flat tile where applicable and matching characteristics of adjoining floor and wall tile.
- C. Ceramic Tile (WT-1 and WT-2): Polished and glazed ceramic wall tile.
1. Products: Refer to Refer to Finish Material Schedule, Sheet #F100
 2. Tile Color, Glaze, and Pattern: As indicated by manufacturer's designations. Refer to Finish Material Schedule, Drawing Sheet #F100.
 3. Grout Color: As indicated by manufacturer's designations. Refer to Finish Material Schedule, Drawing Sheet #F100.
 4. Trim Units: Coordinated with sizes and coursing of adjoining flat tile where applicable and matching characteristics of adjoining flat tile. Provide shapes as follows, selected from manufacturer's standard shapes:
 5. External Corners: Surface bullnose, module size same as adjoining flat tile.

2.3 WATERPROOF BUILDING PANELS, CURB AND MEMBRANE

- A. General: Manufacturer's standard products for waterproof shower wall and floor system that includes waterproof building-panels, base, curb and waterproof membrane complying with ANSI A118.10. Include installation products and accessories required by manufacturer for a complete shower system ready to receive tile finish.
- B. Manufacturer: Subject to compliance with requirements, provide products by the following:
1. Schluter Systems L.P, www.schluter.com.
- C. Product: Kerdi-Board Waterproof Building Panel System.
1. Kerdi-Board Thickness: 1/2 inch (12.7 mm).
 2. Base: Kerdi-Shower-T/-TS/-TT/-LT/-R.
 3. Curb: Kerdi-Board-SC.
 4. Waterproof Membrane: Kerdi
 5. Accessories and installation materials required for installation.

2.4 CRACK ISOLATION MEMBRANE

- A. General: Manufacturer's standard product, selected from the following, that complies with ANSI A118.12 for standard performance and is recommended by the manufacturer for the application indicated. Include reinforcement and accessories recommended by manufacturer.
- B. Chlorinated Polyethylene Sheet: Nonplasticized, chlorinated polyethylene faced on both sides with nonwoven polyester fabric; 0.030-inch (0.76-mm) nominal thickness.

1. Noble Company (The).
- C. Polyethylene Sheet: Polyethylene faced on both sides with fleece webbing; 0.008-inch (0.2-mm) nominal thickness.
1. Schluter Systems L.P., www.schluter.com.

2.5 SETTING MATERIALS

- A. Modified Dry-Set Mortar (Thinset): ANSI A118.4.
1. Provide prepackaged, dry-mortar mix to which only water must be added at Project site.
 2. Provide prepackaged, dry-mortar mix combined with liquid-latex additive at Project site.
 3. For wall applications, provide nonsagging mortar.
- B. Water-Cleanable, Tile-Setting Epoxy: ANSI A118.3.

2.6 GROUT MATERIALS

- A. Sand-Portland Cement Grout: ANSI A108.10, consisting of white or gray cement and white or colored aggregate as required to produce color indicated.
- B. High-Performance Tile Grout: ANSI A118.7.
1. Polymer Type: Dry, redispersible form, prepackaged with other dry ingredients.
 2. Polymer Type: Liquid-latex form for addition to prepackaged dry-grout mix.
- C. Water-Cleanable Epoxy Grout: ANSI A118.3, with a VOC content of 65 g/L or less.

2.7 MISCELLANEOUS MATERIALS

- A. Trowelable Underlayments and Patching Compounds: Latex-modified, portland cement-based formulation provided or approved by manufacturer of tile-setting materials for installations indicated.
- B. Metal Edge Strips: L-shape and ramp, height to match tile and setting-bed thickness, satin anodized aluminum designed specifically for flooring applications; exposed-edge material.
1. Schluter Systems L.P., www.schluter.com; Provide Schluter “Reno Ramp” and “Schiene” finishing and edge protection of thickness to match face of Porcelain tile. Refer to Details on Drawing Sheet F0.2.1.
- C. Grout Sealer: Manufacturer's standard product for sealing grout joints and that does not change color or appearance of grout.
1. Grout sealers shall comply with requirements of FloorScore certification.

PART 3 - EXECUTION

3.1 EXAMINATION

- A. Examine substrates, areas, and conditions where tile will be installed, with Installer present, for compliance with requirements for installation tolerances and other conditions affecting performance of the Work.
1. Verify that substrates for setting tile are firm; dry; clean; free of coatings that are incompatible with tile-setting materials, including curing compounds and other substances that contain soap, wax, oil, or silicone; and comply with flatness tolerances required by ANSI A108.01 for installations indicated.
 2. Verify that concrete substrates for tile floors installed with thinset mortar comply with surface finish requirements in ANSI A108.01 for installations indicated.
 3. Verify that surfaces that received a steel trowel finish have been mechanically scarified.
 4. Verify that protrusions, bumps, and ridges have been removed by sanding or grinding.
 5. Verify that installation of grounds, anchors, recessed frames, electrical and mechanical units of work, and similar items located in or behind tile has been completed.
 6. Verify that joints and cracks in tile substrates are coordinated with tile joint locations; if not coordinated, adjust joint locations in consultation with Architect.
- B. Proceed with installation only after unsatisfactory conditions have been corrected.

3.2 PREPARATION

- A. Fill cracks, holes, and depressions in concrete substrates for tile floors installed with thinset mortar with trowelable leveling and patching compound specifically recommended by tile-setting material manufacturer.
- B. Where indicated, prepare substrates to receive waterproofing by applying a reinforced mortar bed that complies with ANSI A108.1A and is sloped 1/4 inch per foot (1:50) toward drains.
- C. Blending: For tile exhibiting color variations, verify that tile has been factory blended and packaged so tile units taken from one package show same range of colors as those taken from other packages and match approved Samples. If not factory blended, either return to manufacturer or blend tiles at Project site before installing.

3.3 CERAMIC TILE INSTALLATION

- A. Comply with the latest edition of TCNA's "Handbook for Ceramic, Glass, and Stone Tile Installation" for TCNA installation methods specified in tile installation schedules. Comply with parts of the ANSI A108 series "Specifications for Installation of Ceramic Tile" that are referenced in TCNA installation methods, specified in tile installation schedules, and apply to types of setting and grouting materials used.
1. For the following installations, follow procedures in the ANSI A108 series of tile installation standards for providing 95 percent mortar coverage:

- a. Tile floors consisting of tiles 8 by 8 inches (200 by 200 mm) or larger.
 - b. Tile floors consisting of rib-backed tiles.
- B. Extend tile work into recesses and under or behind equipment and fixtures to form complete covering without interruptions unless otherwise indicated. Terminate work neatly at obstructions, edges, and corners without disrupting pattern or joint alignments. Provide metal edge strips at all exposed edges of porcelain tile.
- C. Accurately form intersections and returns. Perform cutting and drilling of tile without marring visible surfaces. Carefully grind cut edges of tile abutting trim, finish, or built-in items for straight aligned joints. Fit tile closely to electrical outlets, piping, fixtures, and other penetrations so plates, collars, or covers overlap tile.
- D. Provide manufacturer's standard trim shapes where necessary to eliminate exposed tile edges.
- E. Jointing Pattern: Lay tile in grid patterns as indicated on the Finish Plans and Schedule. Lay out tile work and center tile fields in both directions in each space or on each wall area. Lay out tile work to minimize the use of pieces that are less than half of a tile. Provide uniform joint widths unless otherwise indicated.
- F. Joint Widths: Except where otherwise indicated on Finish Material Schedule, install tile with the following joint widths:
1. Porcelain Floor Tile: 1/8 inch (3.2 mm).
 2. Mosaic Floor Tile: 1/16 inch (1.6 mm)
 3. Wall Tile: 1/8 inch (3.2 mm).
- G. Expansion Joints: Provide expansion joints and other sealant-filled joints, including control, contraction, and isolation joints, where indicated. Form joints during installation of setting materials, mortar beds, and tile. Do not saw-cut joints after installing tiles.
1. Where control joints occur in concrete substrates, locate joints in tile surfaces directly above them.
- H. Grout Sealer: Apply grout sealer to cementitious grout joints in tile floors according to grout-sealer manufacturer's written instructions. As soon as grout sealer has penetrated grout joints, remove excess sealer and sealer from tile faces by wiping with soft cloth.
- I. Install waterproof membrane to comply with ANSI A108.13 and manufacturer's written instructions to produce waterproof membrane of uniform thickness that is bonded securely to substrate.
- J. Install crack isolation membrane to comply with ANSI A108.17 and manufacturer's written instructions to produce membrane of uniform thickness that is bonded securely to substrate.
- 3.4 INTERIOR CERAMIC TILE INSTALLATION SCHEDULE
- A. Interior Floor Installations, Concrete and Gyp-Crete Subfloor:

1. Ceramic Tile Installation: TCNA F125-Full, thinset mortar on crack isolation membrane.
 - a. Ceramic Tile Type: Refer to Finish Material Schedule, Sheet #F100.
 - b. Thinset Mortar: Modified dry-set mortar.
 - c. Grout: High-performance sanded grout.

- B. Interior Wall Installations, Wood Studs or Furring:
 1. Ceramic Tile Installation: TCNA W245 or TCNA W248; thinset mortar on glass-mat, water-resistant gypsum backer board.
 - a. Ceramic Tile Type: Refer to Finish Material Schedule, Sheet #F100.
 - b. Thinset Mortar: Modified dry-set mortar.
 - c. Grout: High-performance unsanded grout.

- C. Shower Receptor and Wall Installations:
 1. Ceramic Tile Installation: TCNA B415; water-cleanable, tile-setting epoxy on waterproof membrane over cementitious backer units or fiber-cement backer board.
 - a. Ceramic Tile Type: Refer to Finish Material Schedule, Sheet #F100.
 - b. Thinset Mortar: Water-Cleanable, Tile-Setting Epoxy mortar.
 - c. Grout: Water-cleanable epoxy grout.

END OF SECTION 093013

THIS PAGE INTENSIONALLY LEFT BLANK

SECTION 096513 - RESILIENT BASE AND ACCESSORIES

PART 1 - GENERAL

1.1 SUMMARY

- A. Section Includes:
1. Resilient base.
 2. Resilient molding accessories.

1.2 SUBMITTALS

- A. Product Data: For each type of product.
- B. Samples: For each exposed product and for each color and texture specified, not less than 12 inches (300 mm) long.

PART 2 - PRODUCTS

2.1 PERFORMANCE REQUIREMENTS

- A. FloorScore Compliance: Resilient base and accessories shall comply with requirements of FloorScore certification.

2.2 THERMOPLASTIC-RUBBER BASE

- A. Manufacturers: Subject to compliance with requirements, provide products by Tarkett Company.
- B. Product Standard: ASTM F 1861, Type TP (rubber, thermoplastic).
1. Group: I (solid, homogeneous).
 2. Style: Cove
- C. Thickness: 0.125 inch (3.2 mm).
- D. Height: 2.5 inches (63.5 mm).
- E. Lengths: Cut lengths 48 inches (1219 mm) long.
- F. Outside Corners: Job formed.
- G. Inside Corners: Job formed.

- H. Color: Refer to Finish Materials Schedule, Drawing Sheet #F100.

2.3 RUBBER MOLDING ACCESSORIES

- A. Manufacturers: Subject to compliance with requirements, provide products as listed in Finish Schedule on Drawings or by the following:
1. Roppe Corporation, USAJohnsonite; A Tarkett Company, at cove base locations.
- B. Description: Rubber carpet edge for glue-down applications, reducer strip for resilient flooring joiner for tile and carpet and transition strips.
- C. Profile and Dimensions: As indicated on Drawings and at intersections of finish flooring and sealed concrete floor.
- D. Colors and Patterns: Color to match wall base.

2.4 INSTALLATION MATERIALS

- A. Adhesives: Water-resistant type recommended by resilient-product manufacturer for resilient products and substrate conditions indicated.
1. Adhesives shall have a VOC content of 50 g/L or less.

PART 3 - EXECUTION

3.1 PREPARATION

- A. Prepare substrates according to manufacturer's written instructions to ensure adhesion of resilient products.
- B. Fill cracks, holes, and depressions in substrates with trowelable leveling and patching compound; remove bumps and ridges to produce a uniform and smooth substrate.
- C. Do not install resilient products until they are the same temperature as the space where they are to be installed.
- D. Immediately before installation, sweep and vacuum clean substrates to be covered by resilient products.

3.2 RESILIENT BASE INSTALLATION

- A. Comply with manufacturer's written instructions for installing resilient base.
- B. Apply resilient base to walls, pilasters, casework and cabinets in toe spaces, and other permanent fixtures in rooms and areas where base is required.

- C. Install resilient base in lengths as long as practical without gaps at seams and with tops of adjacent pieces aligned.
- D. Tightly adhere resilient base to substrate throughout length of each piece, with base in continuous contact with horizontal and vertical substrates.
- E. Do not stretch resilient base during installation.
- F. Job-Formed Corners:
 - 1. Outside Corners: Use straight pieces of maximum lengths possible and form with returns not less than 3 inches (76 mm) in length.
 - a. Form without producing discoloration (whitening) at bends.
 - 2. Inside Corners: Use straight pieces of maximum lengths possible and form with returns not less than 3 inches (76 mm) in length. Miter or cope corners to minimize open joints.

3.3 RESILIENT ACCESSORY INSTALLATION

- A. Comply with manufacturer's written instructions for installing resilient accessories.
- B. Resilient Molding Accessories: Butt to adjacent materials and tightly adhere to substrates throughout length of each piece. Install reducer strips at edges of floor covering that would otherwise be exposed.

3.4 CLEANING AND PROTECTION

- A. Comply with manufacturer's written instructions for cleaning and protecting resilient products.

END OF SECTION 096513

THIS PAGE INTENSIONALLY LEFT BLANK

SECTION 096516 - RESILIENT SHEET FLOORING

PART 1 - GENERAL

1.1 SUMMARY

A. Section Includes:

1. Rubber-Backed vinyl sheet flooring.

1.2 ACTION SUBMITTALS

- A. Product Data: For each type of product.
- B. Samples: For each exposed product and for each color, texture, and pattern specified.
- C. Manufacturer's Certificates.
- D. Manufacturer's installation instructions.

1.3 QUALITY ASSURANCE

- A. Installer Qualifications: An entity that employs installers and supervisors who are competent in techniques required by manufacturer for rubber-backed vinyl sheet flooring installation and seaming method indicated.
 1. Engage an installer who employs workers for this Project who are trained or certified by rubber-backed vinyl sheet flooring manufacturer for installation techniques required.

1.4 FIELD CONDITIONS

- A. Comply with manufacturer's requirements for project conditions including the following:
 1. Maintain ambient temperatures of 68 deg F (18 deg C) and 80 deg F (26 deg C) in spaces to receive resilient products for 72 hours before installation, during installation and 24 hours after installation.
 2. Maintain the ambient relative humidity between 40 percent and 60 percent during installation.
 3. Provide field measurements prior to fabrication and record on shop drawings.
 4. Close spaces to traffic during vinyl sheet flooring installation until the installer confirms that the adhesive has set.

5. Verify permanent HVAC is operational. If temporary heat is required, use electric or indirect heat sources. Do not use kerosene or propane in direct contact with the ambient air.
6. Verify other finishing operations, including painting, have been completed.

1.5 WARRANTY

- A. Special Limited Warranty: Manufacturer's standard form in which manufacturer agrees to repair or replace sports flooring that fails within specified warranty period.
 1. Material warranty must be direct from the product manufacturer.
 - a. Material warranties from separate or third party insurance providers are not valid.
 - b. Material warranties from private label distributors are not valid.
 2. Failures include, but are not limited to, the following:
 - a. Material manufacturing defects.
 - b. Surface wear and deterioration to the point of wear-through.
 - c. Failure due to substrate moisture exposure not exceeding 92 percent relative humidity when tested according to ASTM F2170 or 10 pounds moisture vapor emission rate when tested according to ASTM F1869.
 3. Warranty Period:
 - a. For materials and manufacturing defects and surface wear-through 10 years from date of Substantial Completion.

PART 2 - PRODUCTS

2.1 PERFORMANCE REQUIREMENTS

- A. Fire-Test-Response Characteristics: Class 1, as determined by testing identical products according to ASTM E648 or NFPA 253 by a qualified testing agency.
 1. Critical Radiant Flux Classification: Class I, not less than 0.45 W/sq. cm.

2.2 RUBBER-BACKED VINYL SHEET FLOORING

- A. Manufacturer: Subject to compliance with requirements, provide products by the following:
 1. Ecore International distributed by Ecore Commercial, Lancaster, PA, 717-295-3400, www.ecorecommercial.com.
- B. Provide Ecore Commercial Forest Rx vulcanized Composition Rubber-Backed resilient sheet vinyl flooring and accessories complying with the following:

1. Wear Layer/Overall Thickness: 2.0 mm vinyl wear layer with print film surface and an overall thickness of 7 mm.
 2. Roll/Sheet Width & Length: 6 feet wide x 30 feet long.
 3. Backing: 5 mm vulcanized composition rubber backing, fusion bonded to wear layer..
 4. Sheet Weight: 1.26 lbs/sq.ft. (6130 g/sq.m).
- C. Colors and Patterns: As indicated on Finish Materials Schedule, Drawing Sheet #F100.

2.3 INSTALLATION MATERIALS

- A. Adhesives: Water-resistant type recommended and supplied by flooring manufacturer for rubber-backed vinyl sheet flooring and substrate conditions indicated.

PART 3 - EXECUTION

3.1 PREPARATION

- A. Prepare substrates according to resilient sheet flooring manufacturer's written instructions to ensure adhesion of resilient sheet flooring.
- B. Gyp-Crete Substrates: Prepare according to ASTM F710.
1. Verify that substrates are dry and free of curing compounds, sealers, and hardeners.
 2. Remove substrate coatings and other substances that are incompatible with adhesives and that contain soap, wax, oil, or silicone, using mechanical methods recommended by resilient sheet flooring manufacturer. Do not use solvents.
 3. Alkalinity and Adhesion Testing: Perform tests recommended by vinyl sheet flooring manufacturer. Proceed with installation only after substrate alkalinity falls within range on pH scale recommended by manufacturer in writing, but not less than 7 or more than 9.9 pH.
 4. Moisture Testing: Perform tests so that each test area does not exceed 200 sq. ft. (18.6 sq. m), and perform no fewer than three tests in each installation area and with test areas evenly spaced in installation areas.
 - a. Relative Humidity Test: Using in-situ probes, ASTM F2170. Proceed with installation only after substrates have a maximum **75** percent relative humidity level measurement.
- C. Fill cracks, holes, and depressions in substrates with trowelable leveling and patching compound; remove bumps and ridges to produce a uniform and smooth substrate.
- D. Do not install resilient sheet flooring until materials are the same temperature as space where they are to be installed.
1. At least 48 hours in advance of installation, move flooring and installation materials into spaces where they will be installed.

- E. Immediately before installation, sweep and vacuum clean substrates to be covered by resilient sheet flooring.

3.2 RUBBER-BACKED VINYL SHEET FLOORING INSTALLATION

- A. Comply with manufacturer's written instructions for installing rubber-backed vinyl sheet flooring.
- B. Unroll sheet flooring and allow it to stabilize before cutting and fitting.
- C. Lay out sheet flooring as follows:
 - 1. Maintain uniformity of flooring direction.
 - 2. Minimize number of seams; place seams in inconspicuous and low-traffic areas, at least 6 inches (152 mm) away from parallel joints in flooring substrates. Avoid cross seams.
 - 3. Match edges of flooring for color shading at seams.
- D. Scribe and cut resilient sheet flooring to butt neatly and tightly to vertical surfaces and permanent fixtures including built-in furniture, cabinets, pipes, outlets, and door frames.
- E. Extend resilient sheet flooring into toe spaces, door reveals, closets, and similar openings.
- F. Adhere resilient sheet flooring to substrates using a full spread of adhesive applied to substrate to produce a completed installation without open cracks, voids, raising and puckering at joints, telegraphing of adhesive spreader marks, and other surface imperfections.

3.3 CLEANING AND PROTECTION

- A. Comply with manufacturer's written instructions for cleaning and protection of resilient products. Perform the following operations immediately after completing resilient product installation:
 - 1. Remove adhesive and other blemishes from exposed surfaces.
 - 2. Sweep and vacuum surfaces thoroughly.
 - 3. Damp-mop surfaces to remove marks and soil.
- B. Protect resilient products from mars, marks, indentations, and other damage from construction operations and placement of equipment and fixtures during remainder of construction period.
 - 1. No traffic for 24 hours after installation.
 - 2. No heavy traffic, rolling loads, or furniture placement for 72 hours after installation.
- C. Wait 72 hours after installation before performing cleaning.

END OF SECTION 096516

SECTION 096519 - RESILIENT TILE FLOORING

PART 1 - GENERAL

1.1 SUMMARY

- A. Section Includes:
1. Solid vinyl floor plank (LVL)
 2. Vinyl composition floor tile.

1.2 ACTION SUBMITTALS

- A. Product Data: For each type of product.
- B. Samples: Full-size units of each color and pattern of floor tile required.

1.3 CLOSEOUT SUBMITTALS

- A. Maintenance data.

1.4 QUALITY ASSURANCE

- A. Installer Qualifications: A qualified installer who employs workers for this Project who are competent in techniques required by manufacturer for floor tile installation.
- B. Mockups: Build mockups to verify selections made under Sample submittals and to demonstrate aesthetic effects and set quality standards for materials and execution.
1. Build mockups for floor tile including resilient base.
 - a. Size: Minimum 50 sq. ft. (4.7 sq. m) for each type, color, and pattern.
 2. Approval of mockups does not constitute approval of deviations from the Contract Documents contained in mockups unless Architect specifically approves such deviations in writing.
 3. Subject to compliance with requirements, approved mockups may become part of the completed Work if undisturbed at time of Substantial Completion.

1.5 DELIVERY, STORAGE, AND HANDLING

- A. Store floor tile and installation materials in dry spaces protected from damage and the weather, with ambient temperatures maintained within range recommended by manufacturer, but not less than 50 deg F (10 deg C) or more than 90 deg F (32 deg C). Store floor tiles on flat surfaces.

1.6 FIELD CONDITIONS

- A. Maintain ambient temperatures within range recommended by manufacturer, but not less than 70 deg F (21 deg C) or more than 95 deg F (35 deg C), in spaces to receive floor tile during the following time periods:
 - 1. 48 hours before installation.
 - 2. During installation.
 - 3. 48 hours after installation.
- B. After installation and until Substantial Completion, maintain ambient temperatures within range recommended by manufacturer, but not less than 55 deg F (13 deg C) or more than 95 deg F (35 deg C).
- C. Close spaces to traffic during floor tile installation.
- D. Close spaces to traffic for 48 hours after floor tile installation.

PART 2 - PRODUCTS

2.1 PERFORMANCE REQUIREMENTS

- A. Fire-Test-Response Characteristics: For resilient tile flooring, as determined by testing identical products according to ASTM E 648 or NFPA 253 by a qualified testing agency.
 - 1. Critical Radiant Flux Classification: Class I, not less than 0.45 W/sq. cm.

2.2 SOLID VINYL FLOOR PLANK (LVL)

- A. Manufacturers: Subject to compliance with requirements, provide Parterre and Milliken products.
- B. Tile Standard: ASTM F 1700.
 - 1. Class: Class III printed film vinyl tile.
 - 2. Type: B, embossed surface.
- C. Thickness: 0.127 inch (5.0 mm).
- D. Size: As shown on Drawings.
- A. Colors and Patterns: As listed in Finish Material Schedule, Drawing Sheet #F100.

2.3 VINYL COMPOSITION FLOOR TILE

- A. Manufacturer: Subject to compliance with requirements, provide products by the following:

1. Armstrong World Industries, Inc., Standard Excelon Imperial Texture
- B. Tile Standard: ASTM F 1066, Class 2, through-pattern tile.
- C. Wearing Surface: Smooth.
- D. Thickness: 0.125 inch (3.2 mm).
- E. Size: 12 by 12 inches (305 by 305 mm).
- F. Colors and Patterns: As indicated in Finish Materials Schedule, Drawing Sheet #F100.

2.4 INSTALLATION MATERIALS

- A. LVT Underlayment: Refer to Finish Materials Schedule, Drawing Sheet #F100 for manufacturer and product.
- B. Adhesive: Water-resistant type recommended by floor tile and adhesive manufacturers to suit floor tile and substrate conditions indicated.
 1. Adhesives shall comply with the following limits for VOC content:
 - a. Vinyl Composition Tile Flooring Adhesives: 50 g/L or less.
- C. Floor Polish: Provide protective, liquid floor-polish products recommended by VCT floor tile manufacturer.

PART 3 - EXECUTION

3.1 PREPARATION

- A. Prepare substrates according to floor tile manufacturer's written instructions to ensure adhesion of resilient products.
- B. Concrete and Gyp-Crete Substrates: Prepare according to ASTM F 710.
 1. Verify that substrates are dry and free of curing compounds, sealers, and hardeners.
 2. Remove substrate coatings and other substances that are incompatible with adhesives and that contain soap, wax, oil, or silicone, using mechanical methods recommended by floor tile manufacturer. Do not use solvents.
 3. Alkalinity and Adhesion Testing: Perform tests recommended by floor tile manufacturer. Proceed with installation only after substrate alkalinity falls within range on pH scale recommended by manufacturer in writing, but not less than 5 or more than 9 pH.
 4. Moisture Testing: Proceed with installation only after substrates pass testing according to floor tile manufacturer's written recommendations.
- C. Do not install floor tiles until they are the same temperature as the space where they are to be installed.

- D. Immediately before installation, sweep and vacuum clean substrates to be covered by resilient floor tile.
- E. Install LVT underlayment in accordance with manufacturer's written requirements.

3.2 FLOOR TILE INSTALLATION

- A. Comply with manufacturer's written instructions for installing floor tile.
- B. Lay out floor tiles from center marks established with principal walls, discounting minor offsets, so tiles at opposite edges of room are of equal width. Adjust as necessary to avoid using cut widths that equal less than one-half tile at perimeter. Lay tiles square with room axis.
- C. Match floor tiles for color and pattern by selecting tiles from cartons in the same sequence as manufactured and packaged, if so numbered. Discard broken, cracked, chipped, or deformed tiles. Lay tiles with grain running in one direction (stacked).
- D. Scribe, cut, and fit floor tiles to butt neatly and tightly to vertical surfaces and permanent fixtures including built-in furniture, cabinets, pipes, outlets, and door frames.
- E. Extend floor tiles into toe spaces, door reveals, closets, and similar openings. Extend floor tiles to center of door openings.
- F. Maintain reference markers, holes, and openings that are in place or marked for future cutting by repeating on floor tiles as marked on substrates. Use chalk or other nonpermanent marking device.
- G. Adhere vinyl composition floor tiles to flooring substrates using a full spread of adhesive applied to substrate to produce a completed installation without open cracks, voids, raising and puckering at joints, telegraphing of adhesive spreader marks, and other surface imperfections.
- H. Adhere solid vinyl plank on underlayment in accordance with manufacturer's written requirements..

3.3 CLEANING AND PROTECTION

- A. Comply with manufacturer's written instructions for cleaning and protecting floor tile.
- B. Floor Polish for VCT: Remove soil, adhesive, and blemishes from VCT floor tile surfaces before applying liquid floor polish.
 - 1. Apply one coat(s).
 - 2. Do not apply polish to LVT plank.
- C. Cover floor tile until Substantial Completion.

END OF SECTION 096519

SECTION 097200 - WALL COVERINGS

PART 1 - GENERAL

1.1 SUMMARY

A. Section Includes:

1. Vinyl wall covering.

1.2 ACTION SUBMITTALS

A. Product Data: For each type of product.

- B. Samples: For each type of wall covering and for each color, pattern, texture, and finish specified, full width by 36-inch- (914-mm-) long in size.

1.3 INFORMATIONAL SUBMITTALS

- A. Product test reports.

1.4 QUALITY ASSURANCE

- A. Mock-up: Provide 60 square foot mock-up of specified wall covering. Mock-up shall be approved by Architect and Owner prior to the ordering the required quantity of materials for the Work.

1.5 CLOSEOUT SUBMITTALS

- A. Maintenance data.

PART 2 - PRODUCTS

2.1 PERFORMANCE REQUIREMENTS

- A. Fire-Test-Response Characteristics: As determined by testing identical wall coverings applied with identical adhesives to substrates according to test method indicated below by a qualified testing agency. Identify products with appropriate markings of applicable testing agency.

1. Surface-Burning Characteristics: Comply with ASTM E 84; testing by a qualified testing agency. Identify products with appropriate markings of applicable testing agency.

- a. Flame-Spread Index: 25 or less.
 - b. Smoke-Developed Index: 450 or less.
2. Fire-Growth Contribution: No flashover and heat and smoke release according to NFPA 286.

2.2 VINYL WALL COVERING

- A. Description: Provide Type II vinyl wall covering with Osnaburg fabric backing. Refer to Finish Materials Schedule, Sheet #F100 for product.
1. Width: 52 inches (1321 mm).
 2. Weight: Approx. 20 oz/sq.yd.
 3. Pattern Match: Straight across match.
 4. Horizontal Repeat: 52 inch wide.
 5. Vertical Repeat: 24 inches high with 2/3 drop.

2.3 ACCESSORIES

- A. Adhesive: Mildew-resistant, nonstaining, strippable adhesive, for use with specific wall covering and substrate application indicated and as recommended in writing by wall-covering manufacturer.
- B. Primer/Sealer: Mildew resistant, complying with requirements in Section 099123 "Interior Painting" and recommended in writing by primer/sealer and wall-covering manufacturers for intended substrate.

PART 3 - EXECUTION

3.1 PREPARATION

- A. Comply with manufacturer's written instructions for surface preparation.
- B. Clean substrates of substances that could impair bond of wall covering, including dirt, oil, grease, mold, mildew, and incompatible primers.
- C. Prepare substrates to achieve a smooth, dry, clean, structurally sound surface free of flaking, unsound coatings, cracks, and defects.
1. Moisture Content: Maximum of 5 percent on new plaster, concrete, and concrete masonry units when tested with an electronic moisture meter.
 2. Gypsum Board: Prime with primer as recommended in writing by primer/sealer manufacturer and wall-covering manufacturer.
 3. Painted Surfaces: Treat areas susceptible to pigment bleeding.

- D. Check painted surfaces for pigment bleeding. Sand gloss, semigloss, and eggshell finish with fine sandpaper.
- E. Remove hardware and hardware accessories, electrical plates and covers, light fixture trims, and similar items.
- F. Acclimatize wall-covering materials by removing them from packaging in the installation areas not less than 24 hours before installation.

3.2 WALL-COVERING INSTALLATION

- A. Comply with wall-covering manufacturers' written installation instructions applicable to products and applications indicated.
- B. Cut wall-covering strips in roll number sequence. Change the roll numbers at partition breaks and corners.
- C. Install strips in same order as cut from roll.
- D. Install wall covering without lifted or curling edges and without visible shrinkage.
- E. Install seams vertical and plumb at least 6 inches (150 mm) from outside corners and 6 inches (150 mm) from inside corners unless a change of pattern or color exists at corner. Horizontal seams are not permitted.
- F. Trim edges and seams for color uniformity, pattern match, and tight closure. Butt seams without overlaps or gaps between strips.
- G. Fully bond wall covering to substrate. Remove air bubbles, wrinkles, blisters, and other defects.
- H. Remove excess adhesive at seams, perimeter edges, and adjacent surfaces.
- I. Reinstall hardware and hardware accessories, electrical plates and covers, light fixture trims, and similar items.

END OF SECTION 097200

THIS PAGE LEFT INTENSIONALLY BLANK

SECTION 099113 - EXTERIOR PAINTING

PART 1 - GENERAL

1.1 SUMMARY

- A. Section includes surface preparation and the application of paint systems on the following exterior substrates:
 - 1. Fiber-cement board.
 - 2. Galvanized metal.
 - 3. Wood.
 - 4. Plastic (PVC Trim).

1.2 DEFINITIONS

- A. Gloss Level 1: Not more than 5 units at 60 degrees and 10 units at 85 degrees, according to ASTM D 523.
- B. Gloss Level 3: 10 to 25 units at 60 degrees and 10 to 35 units at 85 degrees, according to ASTM D 523.
- C. Gloss Level 4: 20 to 35 units at 60 degrees and not less than 35 units at 85 degrees, according to ASTM D 523.
- D. Gloss Level 5: 35 to 70 units at 60 degrees, according to ASTM D 523.
- E. Gloss Level 6: 70 to 85 units at 60 degrees, according to ASTM D 523.
- F. Gloss Level 7: More than 85 units at 60 degrees, according to ASTM D 523.

1.3 ACTION SUBMITTALS

- A. Product Data: For each type of product. Include preparation requirements and application instructions.
- B. Samples: For each type of paint system and each color and gloss of topcoat.
- C. Product List: For each product indicated. Include printout of current "MPI Approved Products List" for each product category specified, with the proposed product highlighted.

1.4 MAINTENANCE MATERIAL SUBMITTALS

- A. Furnish extra materials, from the same product run, that match products installed and that are packaged with protective covering for storage and identified with labels describing contents.

1. Paint: Not less than 1 gal. (3.8 L) of each material and color applied.

1.5 QUALITY ASSURANCE

- A. Mockups: Apply mockups of each paint system indicated and each color and finish selected to verify preliminary selections made under Sample submittals and to demonstrate aesthetic effects and set quality standards for materials and execution.
 1. Finish one surface to represent surfaces and conditions for application of each paint system specified in Part 3.
 - a. Vertical fiber-cement board Surface: Provide sample of at least 12 sq. ft. (1 sq. m).
 - b. PVC Trim:: Provide sample of not less than 10 feet in length.
 2. Final approval of color selections will be based on mockups.

PART 2 - PRODUCTS

2.1 MANUFACTURERS

- A. Products: Subject to compliance with requirements, provide products by one of the following manufacturers:
 1. Sherwin Williams (Basis of Design).
 2. Benjamin Moore
 3. Pittsburgh Paints

2.2 PAINT, GENERAL

- A. MPI Standards: Provide products that comply with MPI standards indicated and that are listed in its "MPI Approved Products List."
- B. Material Compatibility:
 1. Provide materials for use within each paint system that are compatible with one another and substrates indicated, under conditions of service and application as demonstrated by manufacturer, based on testing and field experience.
 2. For each coat in a paint system, provide products recommended in writing by manufacturers of topcoat for use in paint system and on substrate indicated.
- C. VOC Content: Provide materials that comply with VOC limits of authorities having jurisdiction.
- D. Colors: As selected by Architect.

2.3 PRIMERS/SEALERS

- A. Primer, Alkali Resistant, Water Based: MPI #3.

2.4 METAL PRIMERS

- A. Primer, Alkyd, Quick Dry, for Metal: MPI #76.
- B. Primer, Galvanized: As recommended in writing by topcoat manufacturer.

2.5 WATER-BASED PAINTS

- A. Latex, Exterior Eggshell (Gloss Level 3): MPI #15.

2.6 SOLVENT-BASED PAINTS

- A. Alkyd, Exterior, Semi-Gloss (Gloss Level 5): MPI #94.

PART 3 - EXECUTION

3.1 EXAMINATION

- A. Examine substrates and conditions, with Applicator present, for compliance with requirements for maximum moisture content and other conditions affecting performance of the Work.
- B. Verify suitability of substrates, including surface conditions and compatibility with existing finishes and primers.
- C. Maximum Moisture Content of Substrates: When measured with an electronic moisture meter as follows:
 - 1. Fiber-Cement Board: 12 percent.
 - 2. Wood: 15 percent.
- D. Proceed with coating application only after unsatisfactory conditions have been corrected.
 - 1. Application of coating indicates acceptance of surfaces and conditions.

3.2 PREPARATION

- A. Comply with manufacturer's written instructions and recommendations in "MPI Manual" applicable to substrates and paint systems indicated.
- B. Clean substrates of substances that could impair bond of paints, including dust, dirt, oil, grease, and incompatible paints and encapsulants.

1. Remove incompatible primers and reprime substrate with compatible primers or apply tie coat as required to produce paint systems indicated.

3.3 APPLICATION

- A. Apply paints according to manufacturer's written instructions and recommendations in "MPI Manual."
- B. Apply paints to produce surface films without cloudiness, spotting, holidays, laps, brush marks, roller tracking, runs, sags, ropiness, or other surface imperfections. Cut in sharp lines and color breaks.

3.4 CLEANING AND PROTECTION

- A. Protect work of other trades against damage from paint application. Correct damage to work of other trades by cleaning, repairing, replacing, and refinishing, as approved by Architect, and leave in an undamaged condition.
- B. At completion of construction activities of other trades, touch up and restore damaged or defaced painted surfaces.

3.5 EXTERIOR PAINTING SCHEDULE

A. Cement Board Substrates:

1. Latex System MPI EXT 3.3J:

- a. Prime Coat: Primer, alkali resistant, water based, MPI #3. Delete prime coat if Cement Board is factory primed.
- b. Intermediate Coat: Latex, exterior, matching topcoat.
- c. Topcoat: Latex, exterior, low sheen (MPI Gloss Level 3-4), MPI #15.

B. Galvanized-Metal Substrates:

1. Alkyd System:

- a. Prime Coat: Primer, galvanized metal, as recommended in writing by topcoat manufacturer for exterior use on galvanized-metal substrates with topcoat indicated.
- b. Intermediate Coat: Exterior alkyd enamel matching topcoat.
- c. Topcoat: Alkyd, exterior, semi-gloss (Gloss Level 5), MPI #94.

C. Wood Substrates: Exposed framing.

1. Latex over Latex Primer System MPI EXT 6.2M:

- a. Prime Coat: Primer, latex for exterior wood, MPI #6.

- b. Intermediate Coat: Latex, exterior, matching topcoat.
- c. Topcoat: Latex, exterior, low sheen (MPI Gloss Level 3-4), MPI #15.

D. Plastic Trim Fabrication Substrates:

1. Latex System MPI EXT 6.8A:

- a. Prime Coat: Primer, bonding, water based, MPI #17. Delete prime coat if Plastic Trim Fabrications are factory primed.
- b. Intermediate Coat: Latex, exterior, matching topcoat.
- c. Topcoat: Latex, exterior, low sheen (MPI Gloss Level 3-4), MPI #15.

END OF SECTION 099113

THIS PAGE INTENSIONALLY LEFT BLANK

SECTION 099123 - INTERIOR PAINTING

PART 1 - GENERAL

1.1 SUMMARY

- A. Section includes surface preparation and the application of paint systems on the following interior substrates:
 - 1. Steel and iron.
 - 2. Galvanized metal.
 - 3. Wood and PVC.
 - 4. Gypsum board.

1.2 DEFINITIONS

- A. MPI Gloss Level 1: Not more than five units at 60 degrees and 10 units at 85 degrees, according to ASTM D 523.
- B. MPI Gloss Level 2: Not more than 10 units at 60 degrees and 10 to 35 units at 85 degrees, according to ASTM D 523.
- C. MPI Gloss Level 3: 10 to 25 units at 60 degrees and 10 to 35 units at 85 degrees, according to ASTM D 523.
- D. MPI Gloss Level 4: 20 to 35 units at 60 degrees and not less than 35 units at 85 degrees, according to ASTM D 523.
- E. MPI Gloss Level 5: 35 to 70 units at 60 degrees, according to ASTM D 523.
- F. MPI Gloss Level 6: 70 to 85 units at 60 degrees, according to ASTM D 523.
- G. MPI Gloss Level 7: More than 85 units at 60 degrees, according to ASTM D 523.

1.3 ACTION SUBMITTALS

- A. Product Data: For each type of product. Include preparation requirements and application instructions.
 - 1. Include Printout of current "MPI Approved Products List" for each product category specified, with the proposed product highlighted.
- B. Samples: For each type of paint system and in each color and gloss of topcoat.

1.4 QUALITY ASSURANCE

- A. Mockups: Apply mockups of each paint system indicated and each color and finish selected to verify preliminary selections made under Sample submittals and to demonstrate aesthetic effects and set quality standards for materials and execution.
 - 1. Architect will select one surface to represent surfaces and conditions for application of each paint system.
 - a. Vertical and Horizontal Surfaces: Provide samples of at least 100 sq. ft. (9 sq. m).
 - b. Other Items: Architect will designate items or areas required.
 - 2. Final approval of color selections will be based on mockups.
 - a. If preliminary color selections are not approved, apply additional mockups of additional colors selected by Architect at no added cost to Owner.

1.5 DELIVERY, STORAGE, AND HANDLING

- A. Store materials not in use in tightly covered containers in well-ventilated areas with ambient temperatures continuously maintained at not less than 45 deg F (7 deg C).
 - 1. Maintain containers in clean condition, free of foreign materials and residue.
 - 2. Remove rags and waste from storage areas daily.

1.6 FIELD CONDITIONS

- A. Apply paints only when temperature of surfaces to be painted and ambient air temperatures are between 50 and 95 deg F (10 and 35 deg C).
- B. Do not apply paints when relative humidity exceeds 85 percent; at temperatures less than 5 deg F (3 deg C) above the dew point; or to damp or wet surfaces.

1.7 EXTRA MATERIALS

- A. Furnish extra materials described below that are from same production run (batch mix) as materials applied and that are packaged for storage and identified with labels describing contents.
 - 1. Quantity: Furnish 3 percent but not less than 1 gal. (3.8 L) of each material and color applied.

PART 2 - PRODUCTS

2.1 MANUFACTURERS

- A. Manufacturers: Subject to compliance with requirements, provide products by the following:
1. Sherwin-Williams Company (The).
 2. ICP Building Solutions Group, Scuffmaster; www.scuffmaster.com., ScrubTough Max.
- B. Products: Subject to compliance with requirements, provide product listed in the interior Finish Material Schedule for the paint category indicated.

2.2 PAINT, GENERAL

- A. MPI Standards: Products shall comply with MPI standards indicated and shall be listed in its "MPI Approved Products Lists."
- B. Material Compatibility:
1. Materials for use within each paint system shall be compatible with one another and substrates indicated, under conditions of service and application as demonstrated by manufacturer, based on testing and field experience.
 2. For each coat in a paint system, products shall be recommended in writing by topcoat manufacturers for use in paint system and on substrate indicated.
- C. VOC Content: Products shall comply with VOC limits of authorities having jurisdiction and, for interior paints and coatings applied at Project site, the following VOC limits, exclusive of colorants added to a tint base, when calculated according to 40 CFR 59, Subpart D (EPA Method 24).
1. Flat Paints and Coatings: 50 g/L.
 2. Nonflat Paints and Coatings: 150 g/L.
 3. Dry-Fog Coatings: 400 g/L.
 4. Primers, Sealers, and Undercoaters: 200 g/L.
 5. Anticorrosive and Antirust Paints Applied to Ferrous Metals: 250 g/L.
 6. Zinc-Rich Industrial Maintenance Primers: 340 g/L.
 7. Pretreatment Wash Primers: 420 g/L.
 8. Floor Coatings: 100 g/L.
 9. Shellacs, Clear: 730 g/L.
 10. Shellacs, Pigmented: 550 g/L.
- D. Colors: As indicated in the Finish Materials Schedule, Drawing Sheet #F100.

2.3 PREPARATORY COATS

- A. Concrete Unit Masonry Block Filler: High-performance latex block filler of finish coat manufacturer and recommended in writing by manufacturer for use with finish coat and on substrate indicated.
 - 1. Block Filler, Latex, Interior/Exterior: MPI #4.
- B. Interior Primer: Interior latex-based, MPI #50, alkali resistant water based, MPI #3 or alkyd interior, MPI #45, primer of finish coat manufacturer and recommended in writing by manufacturer for use with finish coat and on substrate indicated.
 - 1. Ferrous-Metal Substrates: Quick drying, rust-inhibitive metal primer and tinted undercoat bonding primer for acrylic metallic paint, MPI #107.
 - 2. Zinc-Coated Metal Substrates: Galvanized metal primer, MPI #134.
 - 3. Where manufacturer does not recommend a separate primer formulation on substrate indicated, use paint specified for finish coat.

2.4 INTERIOR FINISH COATS

- A. Interior Flat Paint , (Gloss Level 1): MPI #53:
 - 1. Sherwin-Williams; Harmony Interior Acrylic Latex Paint with no VOC's.
- B. Interior Gloss Paint, (Gloss Level 6): MPI #114:
 - 1. Sherwin-Williams; ProClassic Waterborne Interior Enamel.
- C. Interior Semi-Gloss Paint, (Gloss Level 5): MPI #54:
 - 1. Sherwin-Williams; Harmony Interior Acrylic Latex Paint with no VOC's.
- D. Interior Epoxy-Modified Latex System, (Gloss Level 3): MPI #115 and MPI #254.
 - 1. Sherwin-Williams; Pro Industrial Waterbased Catalyzed Epoxy Gloss, B73-300 Series.
- E. Interior Semi-gloss, Polyurethane Coating.
 - 1. Scuffmaster, Primer, Base and Finish Coat.

PART 3 - EXECUTION

3.1 EXAMINATION

- A. Examine substrates and conditions, with Applicator present, for compliance with requirements for maximum moisture content and other conditions affecting performance of the Work. Verify suitability of substrates, including surface conditions and compatibility with existing finishes and primers. Where acceptability of substrate conditions is in question, apply samples and

perform in-situ testing to verify compatibility, adhesion, and film integrity of new paint application.

- B. Maximum Moisture Content of Substrates: When measured with an electronic moisture meter as follows:
 - 1. Masonry (Clay and CMUs): 12 percent.
 - 2. Wood: 15 percent.
 - 3. Gypsum Board: 12 percent.
- C. Gypsum Board Substrates: Verify that finishing compound is sanded smooth.
- D. Proceed with coating application only after unsatisfactory conditions have been corrected.
 - 1. Application of coating indicates acceptance of surfaces and conditions.

3.2 PREPARATION

- A. Comply with manufacturer's written instructions and recommendations in "MPI Architectural Painting Specification Manual" applicable to substrates and paint systems indicated.
- B. Remove hardware, covers, plates, and similar items already in place that are removable and are not to be painted. If removal is impractical or impossible because of size or weight of item, provide surface-applied protection before surface preparation and painting.
 - 1. After completing painting operations, use workers skilled in the trades involved to reinstall items that were removed. Remove surface-applied protection if any.
- C. Clean substrates of substances that could impair bond of paints, including dust, dirt, oil, grease, and incompatible paints and encapsulants.
 - 1. Remove incompatible primers and reprime substrate with compatible primers or apply tie coat as required to produce paint systems indicated.
- D. Masonry Substrates: Remove efflorescence and chalk. Do not paint surfaces if moisture content or alkalinity of surfaces or mortar joints exceed that permitted in manufacturer's written instructions.
- E. Steel Substrates: Remove rust, loose mill scale, and shop primer, if any. Clean using methods recommended in writing by paint manufacturer, but not less than the following:
 - 1. SSPC-SP 3, "Power Tool Cleaning."
- F. Shop-Primed Steel Substrates: Clean field welds, bolted connections, and abraded areas of shop paint, and paint exposed areas with the same material as used for shop priming to comply with SSPC-PA 1 for touching up shop-primed surfaces.

- G. Galvanized-Metal Substrates: Remove grease and oil residue from galvanized sheet metal fabricated from coil stock by mechanical methods to produce clean, lightly etched surfaces that promote adhesion of subsequently applied paints.
- H. Wood Substrates:
 - 1. Scrape and clean knots, and apply coat of knot sealer before applying primer.
 - 2. Sand surfaces that will be exposed to view, and dust off.
 - 3. Prime edges, ends, faces, undersides, and backsides of wood.
 - 4. After priming, fill holes and imperfections in the finish surfaces with putty or plastic wood filler. Sand smooth when dried.

3.3 APPLICATION

- A. Apply paints according to manufacturer's written instructions and to recommendations in "MPI Manual."
 - 1. Use applicators and techniques suited for paint and substrate indicated.
 - 2. Paint surfaces behind movable equipment and furniture same as similar exposed surfaces. Before final installation, paint surfaces behind permanently fixed equipment or furniture with prime coat only.
 - 3. Paint front and backsides of access panels, removable or hinged covers, and similar hinged items to match exposed surfaces.
 - 4. Do not paint over labels of independent testing agencies or equipment name, identification, performance rating, or nomenclature plates.
 - 5. Primers specified in painting schedules may be omitted on items that are factory primed or factory finished if acceptable to topcoat manufacturers.
- B. Tint each undercoat a lighter shade to facilitate identification of each coat if multiple coats of same material are to be applied. Tint undercoats to match color of topcoat, but provide sufficient difference in shade of undercoats to distinguish each separate coat.
- C. If undercoats or other conditions show through topcoat, apply additional coats until cured film has a uniform paint finish, color, and appearance.
- D. Apply paints to produce surface films without cloudiness, spotting, holidays, laps, brush marks, roller tracking, runs, sags, ropiness, or other surface imperfections. Cut in sharp lines and color breaks.
- E. Painting Fire Suppression, Plumbing, HVAC, Electrical, Communication, and Electronic Safety and Security Work:
 - 1. Paint the following work where exposed in occupied spaces:
 - a. Equipment, including panelboards.
 - b. Uninsulated metal piping.
 - c. Uninsulated plastic piping.
 - d. Pipe hangers and supports.
 - e. Metal conduit.

- f. Plastic conduit.
 - g. Duct, equipment, and pipe insulation having cotton or canvas insulation covering or other paintable jacket material.
 - h. Other items as directed by Architect.
2. Paint portions of internal surfaces of metal ducts, without liner, behind air inlets and outlets that are visible from occupied spaces.

3.4 CLEANING AND PROTECTION

- A. At end of each workday, remove rubbish, empty cans, rags, and other discarded materials from Project site.
- B. After completing paint application, clean spattered surfaces. Remove spattered paints by washing, scraping, or other methods. Do not scratch or damage adjacent finished surfaces.
- C. Protect work of other trades against damage from paint application. Correct damage to work of other trades by cleaning, repairing, replacing, and refinishing, as approved by Architect, and leave in an undamaged condition.
- D. At completion of construction activities of other trades, touch up and restore damaged or defaced painted surfaces.

3.5 INTERIOR PAINTING SCHEDULE

- A. Primed Ferrous Metal :
 - 1. Gloss Finish: Two finish coats over a primer.
 - a. Bonding Primer: All surface enamel latex primer.
 - b. Finish Coats: Interior acrylic enamel paint, MPI #114.
 - 2. Semi-Gloss Finish: Two finish coats over a primer.
 - a. Bonding Primer: All surface enamel latex primer.
 - b. Finish Coats: Interior acrylic enamel paint, MPI #54.
- B. Ferrous Metal:
 - 1. Semi-Gloss Finish: Two finish coats over a primer.
 - a. Primer: Interior ferrous-metal primer.
 - b. Finish Coats: Interior acrylic enamel paint, MPI #54.
- C. Wood Substrates: Wood trim, Architectural woodwork, Doors and Windows.
 - 1. Latex over Latex Primer System:

- a. Prime Coat: Primer sealer, latex, interior: S-W PrepRite ProBlock Primer Sealer, B51-620 Series, MPI #39.
- b. Intermediate Coat: Latex, interior, matching topcoat.
- c. Topcoat: Latex, interior, eggshell: S-W ProMar 200 Zero VOC Latex Eg-Shel, B20-2600 Series, (MPI Gloss Level 5), MPI #54.

D. Gypsum Board:

1. Flat Finish: Two finish coats over a primer.
 - a. Primer: Interior gypsum board primer, MPI #50.
 - b. Finish Coats: Latex, interior, flat, S-W ProMar 200 Zero VOC Latex Flat, B30-2600 Series, MPI #53.
2. Eggshell Finish: Two finish coats over primer.
 - a. Primer: Interior gypsum board primer, MPI #50.
 - b. Finish Coats: Latex, interior, eggshell, S-W ProMar 200 Zero VOC Latex Eg-Shel, B20-2600 Series, MPI #52.
3. Semi-Gloss Finish: Two finish coats over a primer.
 - a. Primer: Interior gypsum board primer, MPI #50.
 - b. Finish Coats: Latex, interior, semi-gloss: S-W ProMar 200 Zero VOC Latex Semi-Gloss, B31-2600 Series, MPI #54.
4. Epoxy-Modified Coating Finish: Two finish coats over a primer in Toilet Rooms and Janitorial Spaces.
 - a. Primer: Primer sealer, latex, interior, S-W ProMar 200 Zero VOC Interior Latex Primer, B28 Series, MPI #50.
 - b. Intermediate Coat: Epoxy-modified latex, interior, matching topcoat.
 - c. Topcoat: Epoxy-modified latex, interior, eggshell, (Gloss Level 3), S-W Pro Industrial Waterbased Catalyzed Epoxy Eggshell, MPI #115.
5. Polyurethane Semi-Gloss Finish: Two finish coats over primer.
 - a. Primer: One coat Scuffermaster Primer/Sealer.
 - b. Finish Coats: Scuffmaster ScrubTough Max.

END OF SECTION 099123

SECTION 099300 - STAINING AND TRANSPARENT FINISHING

PART 1 - GENERAL

1.1 SUMMARY

- A. Section includes surface preparation and application of wood stains and transparent finishes on interior wood substrates.

1.2 DEFINITIONS

- A. MPI Gloss Level 1: Not more than 5 units at 60 degrees and 10 units at 85 degrees, according to ASTM D 523.
- B. MPI Gloss Level 4: 20 to 35 units at 60 degrees and not less than 35 units at 85 degrees, according to ASTM D 523.
- C. MPI Gloss Level 5: 35 to 70 units at 60 degrees, according to ASTM D 523.
- D. MPI Gloss Level 6: 70 to 85 units at 60 degrees, according to ASTM D 523.
- E. MPI Gloss Level 7: More than 85 units at 60 degrees, according to ASTM D 523.

1.3 SUBMITTALS

- A. Product Data: For each type of product. Include preparation requirements and application instructions.
 - 1. Include printout of current "MPI Approved Products List" for each product category specified, with the proposed product highlighted.
- B. Samples: For each type of finish system and in each color and gloss of finish required.

1.4 QUALITY ASSURANCE

- A. Mockups: Apply mockups of each finish system indicated and each color selected to verify preliminary selections made under Sample submittals, to demonstrate aesthetic effects, and to set quality standards for materials and execution.
 - 1. Architect will select one surface to represent surfaces and conditions for application of each type of finish system and substrate.
 - 2. Final approval of stain color selections will be based on mockups.
 - a. If preliminary stain color selections are not approved, apply additional mockups of additional stain colors selected by Architect at no added cost to Owner.

PART 2 - PRODUCTS

2.1 MATERIALS, GENERAL

- A. MPI Standards: Products shall comply with MPI standards indicated and shall be listed in its "MPI Approved Products List."
- B. Material Compatibility:
 - 1. Materials for use within each paint system shall be compatible with one another and substrates indicated, under conditions of service and application as demonstrated by manufacturer, based on testing and field experience.
 - 2. For each coat in a paint system, products shall be recommended in writing by manufacturers of topcoat for use in paint system and on substrate indicated.
- C. VOC Content: Products shall comply with VOC limits of authorities having jurisdiction and, for interior stains and finishes applied at project site, the following VOC limits, exclusive of colorants added to a tint base.
 - 1. Clear Wood Finishes, Varnishes: VOC not more than 350 g/L.
 - 2. Stains: VOC not more than 250 g/L.
 - 3. Primers, Sealers, and Undercoaters: 200 g/L.
- D. Stain Colors: As indicated in Finish Materials Schedule, Sheet F100.

PART 3 - EXECUTION

3.1 EXAMINATION

- A. Examine substrates and conditions, with Applicator present, for compliance with requirements for maximum moisture content and other conditions affecting performance of the Work.
- B. Maximum Moisture Content of Exterior Wood Substrates: 15 percent, when measured with an electronic moisture meter.
- C. Maximum Moisture Content of Interior Wood Substrates: 10 percent, when measured with an electronic moisture meter.
- D. Verify suitability of substrates, including surface conditions and compatibility with existing finishes and primers.
- E. Proceed with finish application only after unsatisfactory conditions have been corrected.
 - 1. Beginning finish application constitutes Contractor's acceptance of substrates and conditions.

3.2 PREPARATION

- A. Comply with manufacturer's written instructions and recommendations in "MPI Architectural Painting Specification Manual" applicable to substrates indicated.
- B. Remove hardware, covers, plates, and similar items already in place that are removable. If removal is impractical or impossible because of size or weight of item, provide surface-applied protection before surface preparation and finishing.
 - 1. After completing finishing operations, use workers skilled in the trades involved to reinstall items that were removed. Remove surface-applied protection if any.
- C. Clean and prepare surfaces to be finished according to manufacturer's written instructions for each substrate condition and as specified.
 - 1. Remove dust, dirt, oil, and grease by washing with a detergent solution; rinse thoroughly with clean water and allow to dry. Remove grade stamps and pencil marks by sanding lightly. Remove loose wood fibers by brushing.
 - 2. Remove mildew by scrubbing with a commercial wash formulated for mildew removal and as recommended by stain manufacturer.

3.3 APPLICATION

- A. Apply finishes according to manufacturer's written instructions and recommendations in "MPI Architectural Painting Specification Manual."
- B. Apply finishes to produce surface films without cloudiness, holidays, lap marks, brush marks, runs, ropiness, or other surface imperfections.

3.4 CLEANING AND PROTECTION

- A. Protect work of other trades against damage from finish application. Correct damage by cleaning, repairing, replacing, and refinishing, as approved by Architect, and leave in an undamaged condition.
- B. At completion of construction activities of other trades, touch up and restore damaged or defaced finished wood surfaces.

3.5 INTERIOR WOOD -FINISH-SYSTEM SCHEDULE

- A. Wood Substrates: Wood trim, architectural woodwork, stair treads and handrail.
 - 1. Polyurethane Varnish over Stain System MPI INT 6.3E:
 - a. Stain Coat: Stain, semitransparent, for interior wood, MPI #90.
 - b. First Intermediate Coat: Polyurethane varnish matching topcoat.
 - c. Second Intermediate Coat: Polyurethane varnish matching topcoat.

- d. Topcoat: Varnish, interior, polyurethane, oil modified, gloss (MPI Gloss Level 6), MPI #56.

END OF SECTION 099300

SECTION 102600 - WALL AND DOOR PROTECTION

PART 1 - GENERAL

1.1 SUMMARY

A. Section Includes:

1. Wall protection system with integral base.

1.2 ACTION SUBMITTALS

A. Product Data: For each type of product.

B. Shop Drawings: For each type of wall protection showing locations and extent.

1. Include plans, elevations and sections.

C. Samples: For each exposed product and for each color and texture specified, 12 inches (300 mm) square or 12 inches (300 mm) long.

1.3 INFORMATIONAL SUBMITTALS

A. Product certificates.

B. Material certificates.

C. Sample warranty.

1.4 CLOSEOUT SUBMITTALS

A. Maintenance data.

1.5 QUALITY ASSURANCE

A. Installer qualifications: Engage an installer who has no less than 3 years experience in installation of systems similar in complexity to those required for this project.

B. Manufacturer's qualifications: Not less than 5 years experience in the production of specified products and a record of successful in-service performance.

C. Single source responsibility: Provide all components of the wall protection system manufactured by the same company to ensure compatibility of color, texture and physical properties.

1.6 DELIVERY, STORAGE, AND HANDLING

- A. Deliver materials to the project site in unopened original factory packaging clearly labeled to show manufacturer.
- B. Store materials in original, undamaged packaging in a clean, dry place out of direct sunlight and exposure to the elements. A minimum room temperature of 40°F (4°C) and a maximum of 100°F (38°C) should be maintained. Materials must be stored flat.
- C. Materials must be acclimated in an environment of 65-75°F (18-24°C) for at least 24 hours prior to beginning the installation.
- D. Installation areas must be enclosed and weatherproofed before installation commences.

1.7 WARRANTY

- A. Special Warranty: Manufacturer agrees to repair or replace components of wall protection units that fail in materials or workmanship within specified warranty period.
 - 1. Warranty Period: Five years from date of Substantial Completion.

PART 2 - PRODUCTS

2.1 PERFORMANCE REQUIREMENTS

- A. Surface Burning Characteristics: Comply with ASTM E84 or UL 723; testing by a qualified testing agency. Identify products with appropriate markings of applicable testing agency.
 - 1. Flame-Spread Index: 75 or less.
 - 2. Smoke-Developed Index: 450 or less.
- B. Impact Strength: Provide rigid wall covering that has been tested in accordance with the applicable provisions of ASTM F476.
- C. Chemical and stain resistance: Provide wall protection system components with chemical and stain resistance in accordance with ASTM D543.
- D. Color match: Provide wall protection components that are color matched in accordance with the following:
 - 1. Delta Ecmc of no greater than 1.0 using CIELab color space.

2.2 MANUFACTURERS

- A. Subject to compliance with performance requirements, provide products by the following manufacturer:

1. Construction Specialties, Inc. Acrovyn, Hughesville, PA, 570-546-5941, www.csgroup.com, Acrovyn 4000 Saratoga Wall System.

2.3 WALL PROTECTION SYSTEM

- A. Wall Protection with Integral Base: Engineered PETG Wall System consisting of rigid sheet and surface mounted trims to achieve desired panelized design
 1. Nominal .060" (1.52mm) thick rigid sheet supplied in 4' x 8' (1.2m x 2.4m) sheet sizes in standard Suede texture.
 2. Trims to be nominal .040" (1.02mm) thick rigid sheet formed over shaped MDF board supplied in 9' 6" (2.9m) lengths and field-mitered. Provide trim thicknesses to minimize exposure of selected components.
 - a. Wainscot trims are 1/2" or 5/8" (12.7mm or 15.9mm) thick in 2", 4", 6" or 8" (50.8mm, 101.6mm, 152.4mm or 203.2mm) widths.
 - b. Vertical trims are 3/8", 1/2" or 5/8" (9.5mm, 12.7mm or 15.9mm) thick in 2", 4", 6" or 8" (50.8mm, 101.6mm, 152.4mm or 203.2mm) widths.
 - c. Horizontal trims are 3/8", 1/2" or 5/8" (9.5mm, 12.7mm or 15.9mm) thick in 2", 4", 6" or 8" (50.8mm, 101.6mm, 152.4mm or 203.2mm) widths.
 - d. Inside/outside corner trims are 3/8", 1/2" or 5/8" (9.5mm, 12.7mm or 15.9mm) thick in 2", 4", 6" or 8" (50.8mm, 101.6mm, 152.4mm or 203.2mm) widths.
 - e. Wall base trims are 1/2" or 5/8" (12.7mm or 15.9mm) thick in 4", 6" or 8" (101.6mm, 152.4mm or 203.2mm) widths.

2.4 MATERIALS

- A. Engineered PETG: High-impact Acrovyn 4000 sheet with Suede texture, nominal .060" (1.52mm) thickness.
- B. Medium Density Fiber (MDF): 3/4" (19.1mm) board material with no added urea formaldehyde.
- C. Adhesive: As provided by wall protection product manufacturer. Adhesive shall be non-hazardous.

PART 3 - EXECUTION

3.1 PREPARATION

- A. Surface preparation: Prior to installation, clean substrate to remove dirt, debris and loose particles. Perform additional preparation procedures as required by manufacturer's instructions.
- B. Protection: Take all necessary steps to prevent damage to material during installation as required in manufacturer's installation instructions

3.2 INSTALLATION

- A. Installation Quality: Install wall protection according to manufacturer's written instructions, level, plumb, and true to line without distortions. Use approved adhesive and locating all components firmly into position. Do not use materials with chips, cracks, voids, stains, or other defects that might be visible in the finished Work.
- B. Temperature at the time of installation must be between 65-75°F (18-24°C) and be maintained for at least 48 hours after the installation to allow for proper adhesive set up. Relative humidity shall not exceed 80%.
- C. Do not expose wall covering to direct sunlight during or after installation. This will cause the surface temperature to rise, which in turn will cause bubbles and delamination..

3.3 CLEANING AND PROTECTION

- A. Immediately upon completion of installation, clean wall covering and accessories in accordance with manufacturer's recommended cleaning method.
- B. Protect installed materials to prevent damage by other trades. Use materials that may be easily removed without leaving residue or permanent stains.

END OF SECTION 102600

SECTION 102800 - TOILET, BATH, AND LAUNDRY ACCESSORIES

PART 1 - GENERAL

1.1 SUMMARY

A. Section Includes:

1. Private-use bathroom accessories.
2. Underlavatory guards.

1.2 ACTION SUBMITTALS

A. Product Data: For each type of product.

B. Samples: For each exposed product and for each finish specified, full size.

1. Approved full-size Samples will be returned and may be used in the Work.

1.3 INFORMATIONAL SUBMITTALS

A. Sample warranties.

1.4 CLOSEOUT SUBMITTALS

A. Maintenance data.

1.5 DELIVERY, STORAGE, AND HANDLING

- A. Do not deliver accessories to site until rooms in which they are to be installed are ready to receive them.
- B. Store packages to prevent physical damage or wetting.
- C. Pack accessories individually in a manner to protect accessory and its finish.
- D. Maintain protective covers on all units until final clean-up.
- E. Protection: Protect adjacent or adjoining finished surfaces and work from damage during installation of work of this Section.

1.6 WARRANTY

- A. Manufacturer's Special Warranty for Mirrors: Manufacturer agrees to repair or replace mirrors that fail in materials or workmanship within specified warranty period.
 - 1. Warranty Period: 15 years from date of Substantial Completion.

PART 2 - PRODUCTS

2.1 PERFORMANCE REQUIREMENTS

- A. Structural Performance: Design accessories and fasteners to comply with the following requirements:
 - 1. Grab Bars: Installed units are able to resist 250 lbf (1112 N) concentrated load applied in any direction and at any point.
 - 2. Shower Seats: Installed units are able to resist 360 lbf (1601 N) applied in any direction and at any point.

2.2 MATERIALS - GENERAL

- A. 18-8, Type 304 stainless steel alloy of at least 22 gauge in all elements of cabinet work. Unless shown otherwise, all exposed stainless steel to have a #4 Satin finish or Satin chrome finish where applicable with all elements of a unit to have brushing in one direction.
- B. Exposed surfaces to be protected with a factory applied PVC film to be left in place until final clean-up.
- C. Fasteners, screws, and bolts: Stainless steel where exposed and hot-dip galvanized where concealed. Expansion shields to be fiber, lead, or rubber as recommended by accessory manufacturer for component substrate. Exposed fasteners to be tamperproof.
- D. Adhesive: Epoxy type contact cement and as recommended by accessory manufacturer.

2.3 PRIVATE-USE BATHROOM ACCESSORIES

- A. Refer to TOILET ACCESSORIES SCHEDULE, Sheet A720 for manufacturers and products. Products include grab bars, framed mirrors, toilet tissue holder, towel ring, shower curtain with rings, shower seat, shower curtain rods, shower niche and robe hook.

2.4 UNDERLAVATORY GUARDS

- A. Underlavatory Guard:
 - 1. Manufacturers: Subject to compliance with requirements, provide products by one of the following:

- a. Plumberex Specialty Products, Inc.
 - b. Truebro by IPS Corporation.
2. Description: Insulating pipe covering for supply and drain piping assemblies that prevents direct contact with and burns from piping; allow service access without removing coverings.
 3. Material and Finish: Antimicrobial, molded plastic, white.

2.5 FABRICATION

- A. Keys: Provide universal keys for internal access to accessories for servicing and resupplying. Provide minimum of six keys to Owner's representative.

PART 3 - EXECUTION

3.1 INSTALLATION

- A. Install accessories according to manufacturers' written instructions, using fasteners appropriate to substrate indicated and recommended by unit manufacturer. Install units level, plumb, and firmly anchored in locations and at heights indicated.
 1. Remove temporary labels and protective coatings.
- B. Grab Bars: Install to comply with specified structural-performance requirements.
- C. Shower Seats: Install to comply with specified structural-performance requirements.

END OF SECTION 102800

THIS PAGE INTENSIONALLY LEFT BLANK

SECTION 104416 - FIRE EXTINGUISHERS

PART 1 - GENERAL

1.1 SUMMARY

- A. Section includes portable, hand-carried fire extinguishers and mounting brackets.

1.2 ACTION SUBMITTALS

- A. Product Data: For each type of product.

1.3 INFORMATIONAL SUBMITTALS

- A. Warranty: Sample of special warranty.

1.4 CLOSEOUT SUBMITTALS

- A. Operation and maintenance data.

1.5 WARRANTY

- A. Special Warranty: Manufacturer's standard form in which manufacturer agrees to repair or replace fire extinguishers that fail in materials or workmanship within specified warranty period.
 - 1. Warranty Period: Five years from date of Substantial Completion.

PART 2 - PRODUCTS

2.1 PERFORMANCE REQUIREMENTS

- A. NFPA Compliance: Fabricate and label fire extinguishers to comply with NFPA 10, "Portable Fire Extinguishers."
- B. Fire Extinguishers: Listed and labeled for type, rating, and classification by an independent testing agency acceptable to authorities having jurisdiction.

2.2 PORTABLE, HAND-CARRIED FIRE EXTINGUISHERS

- A. Fire Extinguishers: Type, size, and capacity for each fire-protection cabinet and mounting bracket indicated.
1. Manufacturers: Subject to compliance with requirements, provide products by one of the following:
 - a. Guardian Fire Equipment, Inc.
 - b. JL Industries, Inc.; a division of the Activar Construction Products Group.
 - c. Larsens Manufacturing Company, MP10, Basis of Design.
 - d. Nystrom Building Products.
 - e. Potter Roemer LLC.
 2. Instruction Labels: Include pictorial marking system complying with NFPA 10, Appendix B, and bar coding for documenting fire-extinguisher location, inspections, maintenance, and recharging.
- B. Multipurpose Dry-Chemical Type: UL-rated 4A-80B.C with 10 lbs. nominal capacity, and monoammonium phosphate-based dry chemical in manufacturer's standard enameled container.

2.3 MOUNTING BRACKETS

- A. Mounting Brackets: Manufacturer's standard steel, designed to secure fire extinguisher to wall or structure, of sizes required for types and capacities of fire extinguishers indicated, with plated or red baked-enamel finish.
1. Manufacturers: Subject to compliance with requirements, provide products by one of the following:
 - a. Guardian Fire Equipment, Inc.
 - b. JL Industries, Inc.; a division of the Activar Construction Products Group.
 - c. Larsens Manufacturing Company.
 - d. Nystrom Building Products.
 - e. Potter Roemer LLC.

PART 3 - EXECUTION

3.1 INSTALLATION

- A. Examine fire extinguishers for proper charging and tagging.
1. Remove and replace damaged, defective, or undercharged fire extinguishers.
- B. Install fire extinguishers on mounting brackets in locations indicated and in compliance with requirements of authorities having jurisdiction.

1. Mounting Brackets: 54 inches (1372 mm) above finished floor to top of fire extinguisher. Fasten mounting brackets to surfaces, square and plumb, at locations indicated.

END OF SECTION 104416

THIS PAGE INTENSIONALLY LEFT BLANK

SECTION 113013 - RESIDENTIAL APPLIANCES AND EQUIPMENT

PART 1 - GENERAL

1.1 SUMMARY

A. Section Includes:

1. Cooking appliances.
2. Kitchen exhaust ventilation.
3. Refrigeration appliances.
4. Cleaning appliances.
5. Sensory Room equipment.
6. Patient ceiling lift system.

1.2 PREINSTALLATION MEETINGS

- A. Preinstallation Conference: Conduct conference at Project site.

1.3 ACTION SUBMITTALS

- A. Product Data: For each type of product.
- B. Shop Drawings: Provide detailed drawings of patient ceiling lift system including layout plans and all anchorage details. Field measure all locations prior to fabrication.

1.4 INFORMATIONAL SUBMITTALS

- A. Product certificates.
- B. Field quality-control reports.
- C. Sample warranties.

1.5 CLOSEOUT SUBMITTALS

- A. Operation and maintenance data.

1.6 QUALITY ASSURANCE

- A. Installer Qualifications: Patient ceiling lift manufacturer will install this system using only qualified personnel trained to perform this work.

1.7 WARRANTY

- A. Special Warranties: Manufacturer agrees to repair or replace residential appliances or components that fail in materials or workmanship within specified warranty period.

1. Warranty Period: Five years from date of Substantial Completion.

PART 2 - PRODUCTS

2.1 PERFORMANCE REQUIREMENTS

- A. Electrical Appliances: Listed and labeled as defined in NFPA 70, by a qualified testing agency, and marked for intended location and application.

2.2 RESIDENTIAL APPLIANCES

- A. Provide the following residential appliances:

1. Cooking appliances include electric oven, induction cooktop, countertop microwave and electric range. Refer to Schedule-Equipment, Sheet A720 for manufacturers, products and descriptions.
2. Kitchen exhaust ventilation appliances include range hood and telescopic downdraft vent. Refer to Schedule-Equipment, Sheet A720 for manufacturers, products and descriptions.
3. Refrigeration appliances include commercial refrigerator, commercial freezer and counter depth, French door refrigerator. Provide appliances that qualify for the EPA/DOE ENERGY STAR product-labeling program. Refer to Schedule-Equipment, Sheet A720 for manufacturers, products and descriptions.
4. Cleaning appliances include dishwasher, washer and dryer. Provide washer that qualify for the EPA/DOE ENERGY STAR product-labeling program. Refer to Schedule-Equipment, Sheet A720 for manufacturers, products and descriptions.

2.3 SENSORY ROOM EQUIPMENT

- A. Provide both fixed and loose items. Refer to Schedule-Specialty Equipment Sensory Rooms, Sheet A720 for manufacturers, products and descriptions.

2.4 PATIENT CEILING LIFT SYSTEM

- A. Provide ceiling mounted patient lift system including non-recessed rail, curtain jumps, continuous charging, 750 lb motor, 6-point spreader bar, turntable and all installation materials for a complete operating system.

- B. Manufacturer: Subject to compliance with requirements, provide product by the following:

1. Tollos, Equipped for Life, Owings Mills, MD, 410-363-1515, www.tollos.com. Sales Manager contact: John Reese, Territory Account Manager.

PART 3 - EXECUTION

3.1 INSTALLATION

- A. Built-in Equipment: Securely anchor units to supporting cabinets or countertops with concealed fasteners. Verify that clearances are adequate for proper functioning and that rough openings are completely concealed.
- B. Freestanding Equipment: Place units in final locations after finishes have been completed in each area. Verify that clearances are adequate to properly operate equipment.
- C. Range Anti-Tip Device: Install at each range according to manufacturer's written instructions.
- D. Install special equipment for Sensory Rooms in accordance with the manufacturer's written instructions for each item that is attached to walls and ceilings. Refer to drawings for locations.
- E. Install patient ceiling lift system in accordance with the manufacturer's written instructions and approved shop drawings.

3.2 FIELD QUALITY CONTROL

- A. Perform the following tests and inspections with the assistance of a factory-authorized service representative:
 - 1. Perform visual, mechanical, and electrical inspection and testing for each appliance according to manufacturers' written recommendations. Certify compliance with each manufacturer's appliance-performance parameters.
 - 2. Leak Test: After installation, test for leaks. Repair leaks and retest until no leaks exist.
 - 3. Operational Test: After installation, start units and equipment to confirm proper operation.
 - 4. Test and adjust controls and safeties. Replace damaged and malfunctioning controls and components.
- B. An appliance will be considered defective if it does not pass tests and inspections.
- C. Prepare test and inspection reports.

END OF SECTION 113013

THIS PAGE INTENSIONALLY LEFT BLANK

SECTION 123623.13 - PLASTIC-LAMINATE-CLAD COUNTERTOPS

PART 1 - GENERAL

1.1 SUMMARY

- A. Section Includes:
 - 1. Plastic-laminate-clad countertops.

1.2 ACTION SUBMITTALS

- A. Product Data: For each type of product.
- B. Shop Drawings: For plastic-laminate-clad countertops.
 - 1. Apply AWI Quality Certification Program label to Shop Drawings.
- C. Samples: Plastic laminates in each type, color, pattern, and surface finish required.

1.3 INFORMATIONAL SUBMITTALS

- A. Product Certificates: For the following:
 - 1. Composite wood products.
 - 2. High-pressure decorative laminate.
 - 3. Adhesives.
- B. Quality Standard Compliance Certificates: AWI Quality Certification Program.

1.4 QUALITY ASSURANCE

- A. Fabricator Qualifications: Shop that employs skilled workers who custom fabricate products similar to those required for this Project and whose products have a record of successful in-service performance.
 - 1. Shop Certification: AWI's Quality Certification Program accredited participant.
- B. Installer Qualifications: Fabricator of products.

PART 2 - PRODUCTS

2.1 PLASTIC-LAMINATE-CLAD COUNTERTOPS

- A. Quality Standard: Unless otherwise indicated, comply with the "Architectural Woodwork Standards" for grades of plastic-laminate-clad countertops indicated for construction, finishes, installation, and other requirements.
 - 1. Provide inspections of fabrication and installation together with labels and certificates from AWI certification program indicating that countertops comply with requirements of grades specified.
- B. Grade: Custom.
- C. High-Pressure Decorative Laminate: NEMA LD 3, Grade HGS.
 - 1. Manufacturers: Subject to compliance with requirements, provide products from manufacturers listed in Finish Materials Schedule, Sheet #AI-201.
 - 2. Colors, Patterns, and Finishes: As indicated on Finish Materials Schedule, Sheet #AI-201, PLASTIC LAMINATE .
- D. Edge Treatment: Same as laminate cladding on horizontal surfaces.
- E. Core Material: As selected by fabricator to comply with quality standard.
- F. Core Material at Sinks: Particleboard made with exterior glue.
- G. Core Thickness: 3/4 inch (19 mm).
 - 1. Build up countertop thickness to 1-1/2 inches (38 mm) at front, back, and ends with additional layers of core material laminated to top.
- H. Backer Sheet: Provide plastic-laminate backer sheet, NEMA LD 3, Grade BKL, on underside of countertop substrate.

2.2 WOOD MATERIALS

- A. Wood Products: Provide materials that comply with requirements of referenced quality standard unless otherwise indicated.
 - 1. Wood Moisture Content: **5 to 10** percent.
- B. Composite Wood Products: Provide materials that comply with requirements of referenced quality standard for each type of countertop and quality grade specified unless otherwise indicated.
 - 1. Particleboard: ANSI A208.1, Grade M-2 and Grade M-2-Exterior Glue.

2.3 ACCESSORIES

- A. Steel Countertop Support Bracket. Provide 21-inch bracket manufactured by CounterBalance, Model #CCH-CBWB 1521PR-IM in black color.
- B. Wire-Management Grommets: Circular, molded-plastic grommets and matching plastic caps with slot for wire passage.
 - 1. Outside Diameter: 2 inches (51 mm).
 - 2. Color: White.

2.4 MISCELLANEOUS MATERIALS

- A. Adhesive for Bonding Plastic Laminate: As selected by fabricator to comply with requirements.
 - 1. Adhesive for Bonding Edges: Hot-melt adhesive or adhesive specified above for faces.

2.5 FABRICATION

- A. Fabricate countertops to dimensions, profiles, and details indicated.
- B. Complete fabrication, including assembly, to maximum extent possible before shipment to Project site. Disassemble components only as necessary for shipment and installation. Where necessary for fitting at site, provide ample allowance for scribing, trimming, and fitting.

PART 3 - EXECUTION

3.1 INSTALLATION

- A. Grade: Install countertops to comply with same grade as item to be installed.
- B. Assemble countertops and complete fabrication at Project site to the extent that it was not completed in the shop.
 - 1. Provide cutouts for appliances, plumbing fixtures, electrical work, and similar items. Locate openings accurately, and use templates or roughing-in diagrams to produce accurately sized and shaped openings. Sand edges of cutouts to remove splinters and burrs.
 - 2. Seal edges of cutouts by saturating with varnish.
- C. Field Jointing: Where possible, make in the same manner as shop jointing, using dowels, splines, adhesives, and fasteners recommended by manufacturer. Prepare edges to be joined in shop so Project-site processing of top and edge surfaces is not required. Locate field joints where shown on Shop Drawings.
 - 1. Secure field joints in countertops with concealed clamping devices located within 6 inches (150 mm) of front and back edges and at intervals not exceeding 24 inches (600

mm). Tighten according to manufacturer's written instructions to exert a constant, heavy-clamping pressure at joints.

- D. Scribe and cut countertops to fit adjoining work, refinish cut surfaces, and repair damaged finish at cuts.
- E. Countertop Installation: Anchor securely by screwing through corner blocks of base cabinets or other supports into underside of countertop.
 - 1. Install countertops level and true in line. Use concealed shims as required to maintain not more than a 1/8-inch-in-96-inches (3-mm-in-2400-mm) variation from a straight, level plane.
 - 2. Secure backsplashes to walls with adhesive.
 - 3. Seal joints between countertop and backsplash, if any, and joints where countertop and backsplash abut walls with mildew-resistant silicone sealant or another permanently elastic sealing compound recommended by countertop material manufacturer.
- F. Protection: Provide Kraft paper or other suitable covering over countertop surfaces, taped to underside of countertop at a minimum of 48 inches (1220 mm) o.c. Remove protection at Substantial Completion.

END OF SECTION 123623.13

SECTION 123661.16 - SOLID SURFACING COUNTERTOPS

PART 1 - GENERAL

1.1 SUMMARY

A. Section Includes:

1. Solid surface material countertops and on millwork.
2. Solid surface material backsplashes and end splashes.
3. Solid surface material sinks.

1.2 ACTION SUBMITTALS

- A. Product Data: For countertop materials and sinks.
- B. Shop Drawings: For countertops. Show materials, finishes, edge and backsplash profiles, methods of joining, and cutouts for plumbing fixtures.
- C. Samples: For each type of material exposed to view.

1.3 FIELD CONDITIONS

- A. Environmental Limitations: Do not deliver or install interior architectural woodwork until building is enclosed, wet-work is complete, and HVAC system is operating and maintaining temperature between 60 and 90 deg F (16 and 32 deg C) and relative humidity between 25 and 55 percent during the remainder of the construction period.

PART 2 - PRODUCTS

2.1 SOLID SURFACE COUNTERTOP MATERIALS

A. Solid Surface Material: Homogeneous-filled plastic resin complying with ICPA SS-1.

1. Manufacturers: Subject to compliance with requirements, provide products from manufacturers listed Finish Materials Schedule, Sheet #AI-201.
2. Colors and Patterns: As indicated on Finish Materials Schedule, Sheet #AI-201 for SURFACES.
3. Flame Spread and Smoke Developed: Class I and Class A rated in accordance with ASTM E84 test procedures.

B. Particleboard: ANSI A208.1, Grade M-2-Exterior Glue.

- C. Plywood: Exterior softwood plywood complying with DOC PS 1, Grade C-C Plugged, touch sanded.

2.2 COUNTERTOP FABRICATION

- A. Fabricate countertops according to solid surface material manufacturer's written instructions and to the AWI/AWMAC/WT's "Architectural Woodwork Standards."
 - 1. Grade: Premium.
- B. Configuration:
 - 1. Front: Straight, slightly eased at top.
 - 2. Backsplash: Straight, slightly eased at corner.
 - 3. End Splash: Matching backsplash.
- C. Countertops: 1/2-inch- (12.7-mm-) thick, solid surface material with front edge built up with same material and integral molded sinks.
- D. Backsplashes: 1/2-inch- (12.7-mm-) thick, solid surface material.
- E. Joints: Fabricate countertops without joints.
- F. Cutouts and Holes:
 - 1. Undercounter Plumbing Fixtures: Make cutouts for fixtures in shop using template or pattern furnished by fixture manufacturer. Form cutouts to smooth, even curves.

2.3 INSTALLATION MATERIALS

- A. Adhesive: Product recommended by solid surface material manufacturer.
- B. Sealant for Countertops: Comply with applicable requirements in Section 079200 "Joint Sealants."

PART 3 - EXECUTION

3.1 INSTALLATION

- A. Fasten countertops by screwing through corner blocks of base units into underside of countertop. Pre-drill holes for screws as recommended by manufacturer.
- B. Fasten subtops to cabinets by screwing through subtops into cornerblocks of base cabinets. Shim as needed to align subtops in a level plane.
- C. Secure countertops to subtops with adhesive according to solid surface material manufacturer's written instructions.

- D. Bond joints with adhesive and draw tight as countertops are set. Mask areas of countertops adjacent to joints to prevent adhesive smears.
- E. Install backsplashes and end splashes by adhering to wall and countertops with adhesive.
- F. Complete cutouts not finished in shop. Mask areas of countertops adjacent to cutouts to prevent damage while cutting. Make cutouts to accurately fit items to be installed, and at right angles to finished surfaces unless beveling is required for clearance. Ease edges slightly to prevent snipping.
- G. Apply sealant to gaps at walls; comply with Section 079200 "Joint Sealants."

END OF SECTION 123661.16

THIS PAGE LEFT INTENTIONALLY BLANK

SECTION 123661.19 - QUARTZ AGGLOMERATE COUNTERTOPS

PART 1 - GENERAL

1.1 SUMMARY

A. Section Includes:

1. Quartz agglomerate countertops.
2. Quartz agglomerate backsplashes and end splashes.

1.2 ACTION SUBMITTALS

- A. Product Data: For countertop materials.
- B. Shop Drawings: For countertops. Show materials, finishes, edge and backsplash profiles, methods of joining, and cutouts for plumbing fixtures.
- C. Samples: For each type of material exposed to view.

1.3 FIELD CONDITIONS

- A. Environmental Limitations: Do not deliver or install interior architectural woodwork until building is enclosed, wet-work is complete, and HVAC system is operating and maintaining temperature between 60 and 90 deg F (16 and 32 deg C) and relative humidity between 25 and 55 percent during the remainder of the construction period.

PART 2 - PRODUCTS

2.1 QUARTZ AGGLOMERATE COUNTERTOP MATERIALS

- A. Quartz Agglomerate: Solid sheets consisting of quartz aggregates bound together with a matrix of filled plastic resin and complying with ICPA SS-1, except for composition.
 1. Manufacturers: Subject to compliance with requirements, provide products from manufacturers listed Finish Materials Schedule, Sheet #AI-201.
 2. Colors and Patterns: As indicated on Finish Materials Schedule, Sheet #AI-201 for SURFACES.
- B. Particleboard: ANSI A208.1, Grade M-2-Exterior Glue.
- C. Plywood: Exterior softwood plywood complying with DOC PS 1, Grade C-C Plugged, touch sanded.

2.2 COUNTERTOP FABRICATION

- A. Fabricate countertops according to quartz agglomerate manufacturer's written instructions and the AWI/AWMAC/WI's "Architectural Woodwork Standards."
 - 1. Grade: Premium.
- B. Configuration:
 - 1. Front: Straight, slightly eased at top.
 - 2. Backsplash: Straight, slightly eased at corner.
 - 3. End Splash: Matching backsplash.
- C. Countertops: 1 3/16-inch- (30.0-mm).
- D. Backsplashes: 9/16-inch- (15.0-mm).
- E. Joints: Fabricate countertops without joints.
- F. Cutouts and Holes:
 - 1. Undercounter Plumbing Fixtures: Make cutouts for fixtures in shop using template or pattern furnished by fixture manufacturer. Form cutouts to smooth, even curves.

2.3 INSTALLATION MATERIALS

- A. Adhesive: Product recommended by quartz agglomerate manufacturer.
- B. Sealant for Countertops: Comply with applicable requirements in Section 079200 "Joint Sealants."

PART 3 - EXECUTION

3.1 INSTALLATION

- A. Fasten countertops by screwing through corner blocks of base units into underside of countertop. Pre-drill holes for screws as recommended by manufacturer.
- B. Fasten subtops to cabinets by screwing through subtops into cornerblocks of base cabinets. Shim as needed to align subtops in a level plane.
- C. Secure countertops to subtops with adhesive according to quartz agglomerate manufacturer's written instructions.
- D. Bond joints with adhesive and draw tight as countertops are set. Mask areas of countertops adjacent to joints to prevent adhesive smears.
- E. Install backsplashes and end splashes by adhering to wall and countertops with adhesive.

- F. Complete cutouts not finished in shop. Mask areas of countertops adjacent to cutouts to prevent damage while cutting. Make cutouts to accurately fit items to be installed, and at right angles to finished surfaces unless beveling is required for clearance. Ease edges slightly to prevent snipping.
- G. Apply sealant to gaps at walls; comply with Section 079200 "Joint Sealants."

END OF SECTION 123661.19

THIS PAGE LEFT INTENTIONALLY BLANK

SECTION 142600 - LIMITED-USE/LIMITED-APPLICATION ELEVATORS

PART 1 - GENERAL

1.1 SUMMARY

A. Section Includes:

1. Limited-use/limited-application (LU/LA) elevators.

1.2 ACTION SUBMITTALS

A. Product Data: Include capacities, sizes, performances, operations, safety features, finishes, and similar information. Include Product Data for car enclosures, hoistway entrances, and operation, control, and signal equipment.

B. Shop Drawings:

1. Include plans, elevations, sections, and large-scale details indicating service at each landing, machine room layout, coordination with building structure, relationships with other construction, and locations of equipment.
2. Indicate loads imposed on building structure at points of support and power requirements.

C. Samples: For finishes involving color selection.

1.3 INFORMATIONAL SUBMITTALS

A. Qualification Data: For Installer.

B. Seismic Qualification Certificates: For elevator equipment, accessories, and components, from manufacturer.

C. Manufacturer Certificates: Signed by elevator manufacturer certifying that hoistway, pit, and machine room layout and dimensions, as shown on Drawings, and electrical service, as shown and specified, are adequate for elevator being provided.

D. Sample warranty.

1.4 CLOSEOUT SUBMITTALS

A. Operation and maintenance data.

B. Inspection and Acceptance Certificates and Operating Permits: As required by authorities having jurisdiction, for normal, unrestricted elevator use.

- C. Continuing Maintenance Proposal: Provide a continuing maintenance proposal from Installer to Owner, in the form of a standard two-year maintenance agreement, starting on date initial maintenance service is concluded.

1.5 WARRANTY

- A. Manufacturer's Special Warranty: Manufacturer agrees to repair or replace elevator work that fails in materials or workmanship within specified warranty period.
 - 1. Warranty Period: Two years from date of Substantial Completion.

PART 2 - PRODUCTS

2.1 MANUFACTURERS

- A. Manufacturers: Subject to compliance with requirements, provide products by the following or approved equivalent:
 - 1. Garaventa Lift, Surrey, BC, V3Z 0P6, Canada, www.garaventlift.com, Elvora LU/LA, Style 1R.

2.2 PERFORMANCE REQUIREMENTS

- A. Regulatory Requirements: Comply with ASME A17.1/CSA B44.
- B. Accessibility Requirements: Comply with requirements for LU/LA elevators in the United States Access Board's ADA-ABA Accessibility Guidelines and with ICC A117.1.
- C. Seismic Performance: Elevator system shall withstand the effects of earthquake motions determined according to ASCE/SEI 7 and shall comply with elevator seismic requirements in ASME A17.1/CSA B44.
 - 1. Project Seismic Design Category: B.
 - 2. Elevator Component Importance Factor: 1.25.
 - 3. Design earthquake spectral response acceleration short period (Sds) for Project is 0.127 g.

2.3 SYSTEMS AND COMPONENTS

- A. Elevator System, General: Manufacturer's standard LU/LA elevator. Unless otherwise indicated, manufacturers' standard components shall be used, as included in standard LU/LA elevators and as required for complete system.
 - 1. Rated Load: 1400 lb (635 kg).
 - 2. Rated Speed: 30 fpm (0.15 m/s).
- B. Machine Type: Hydraulic, holeless, beside the car; cable hydraulic.

- C. Pump Units: Positive-displacement type with a maximum of 10 percent variation between no load and full load and with minimum pulsations.
 - 1. Pump shall be submersible type, suspended inside oil tank from vibration isolation mounts.
 - 2. Motor shall have solid-state starting or variable-voltage, variable-frequency motor control.
 - 3. System shall have hydraulic silencer and flexible piping connectors at pump unit.
- D. Hydraulic Fluid: Elevator manufacturer's standard fluid with additives as needed to prevent oxidation of fluid, corrosion of cylinder and other components, and other adverse effects.

2.4 OPERATION SYSTEMS

- A. Provide manufacturer's standard microprocessor operation system for single automatic operation.
- B. Battery-Powered Lowering: When power fails, car is lowered to the lowest floor, opens its car and hoistway doors, and shuts down. System includes rechargeable battery and automatic recharging system.
- C. Provide automatic operation of lights and ventilation fans.
- D. Emergency Operation: None required.

2.5 CAR ENCLOSURES

- A. Provide steel-framed car enclosures with wall panels, car roof, access doors, power door operators, and ventilation. Provide finished car including materials and finishes specified below.
- B. Clear Inside Dimensions:
 - 1. Inside Width: 48 inches (1219 mm) from sidewall to sidewall.
 - 2. Inside Depth: 54 inches (1370 mm) from back wall to front wall (return panels).
 - 3. Inside Height: 84 inches (2134 mm) to underside of ceiling.
- C. Materials and Finishes: Manufacturer's standards, but not less than the following:
 - 1. Floor Finish:
 - a. Refer to Finish Materials Schedule, Sheet #AI-201 for elevator floor finish.
 - 2. Plastic-Laminate Wall Panels: Plastic laminate adhesively applied to manufacturer's standard metal panels with[manufacturer's standard protective edge trim. Panels will have a flame-spread index of 25 or less, when tested according to ASTM E84. Plastic-laminate color, texture, and pattern as selected by Architect from plastic-laminate or elevator manufacturer's full range. Trim finish to be satin finished stainless steel.

3. Metal Ceiling: Flush panels, fabricated from cold-rolled steel sheet. Provide panels with factory-applied enamel or powder-coat finish; colors as selected by Architect from manufacturer's full range.
 4. Lighting: Four LED downlights.
 5. Handrail: Manufacturer's standard.
- D. Car Doors: Manufacturer's standard units complete with track systems, hardware, sills, and accessories.
1. Operation: Power-operated, automatic.
 2. Type: Horizontal sliding.
 3. Clear Opening Width: 36 inches (915 mm).
 4. Door Height: 80 inches (2032 mm).
 5. Stainless Steel Doors: Flush, hollow-metal construction; fabricated from satin finished stainless steel sheet.

2.6 HOISTWAY ENTRANCES

- A. Provide manufacturer's standard door-and-frame hoistway entrances, same size as car doors, complete with track systems, hardware, sills, and accessories.
1. Operation: Power-operated, automatic.
 2. Type: Horizontal sliding.
- B. Coordinate frame size and profile with hoistway wall construction.
1. Where gypsum board wall construction is indicated, provide self-supporting frames with reinforced head sections.
- C. Materials and Fabrication: Manufacturer's standards, but not less than the following:
1. Stainless Steel Doors: Flush, hollow-metal construction; fabricated from satin finished stainless steel sheet.

2.7 SIGNAL EQUIPMENT

- A. Provide hall-call and car-call buttons that light when activated and remain lit until call has been fulfilled. Provide vandal-resistant buttons and lighted elements illuminated with light-emitting diodes.
1. Finish: Satin stainless steel, ASTM A480/A480M, No. 4 finish.
- B. Car-Control Stations: Provide manufacturer's standard car-control stations. Mount in side panel adjacent to car door unless otherwise indicated.
1. Mark buttons and switches for function. Use both tactile symbols and Braille.

2. Provide "No Smoking" sign matching car-control station, either integral with car-control station or mounted adjacent to it, with text and graphics as required by authorities having jurisdiction.
- C. Emergency Communication System: Two-way voice communication system, with visible signal, which dials preprogrammed number of monitoring station and does not require handset use. System is contained in flush-mounted cabinet, with identification, instructions for use, and battery backup power supply.
- D. Car Position Indicator: Provide digital-type position indicator in elevator car. Also, provide audible signal to indicate to passengers that car is either stopping at or passing each of the floors served. Include travel direction arrows if not provided in car-control station.
- E. Hall Push-Button Stations: Wall-mounted or jamb-mounted units equipped with buttons for calling elevator and for indicating desired direction of travel where applicable.
- F. Hall Lanterns: Wall-mounted or jamb-mounted units with illuminated arrows; but provide single arrow at terminal landings.
- G. Hall Annunciator: Provide audible signals indicating car arrival and direction of travel.
- H. Emergency Pictorial Signs: Fabricate from materials matching hall push-button stations, with text and graphics as required by authorities having jurisdiction, indicating that in case of fire, elevators are out of service and exits should be used instead. Provide one sign at each hall push-button station unless otherwise indicated.

2.8 FINISH MATERIALS

- A. Cold-Rolled Steel Sheet: ASTM A1008/A1008M, commercial steel, Type B, exposed, matte finish.
- B. Hot-Rolled Steel Sheet: ASTM A1011/A1011M, commercial steel, Type B, pickled.
- C. Stainless Steel Sheet: ASTM A240/A240M, Type 304.
- D. Aluminum Extrusions: ASTM B221 (ASTM B221M), Alloy 6063.
- E. Plastic Laminate: High-pressure type complying with NEMA LD 3, Type HGS for flat applications.

PART 3 - EXECUTION

3.1 INSTALLATION

- A. Install cylinder plumb and accurately located for elevator car position and travel. Anchor securely in place, supported at pit floor and braced at intervals as needed to maintain alignment. Anchor cylinder guides at spacing needed to maintain alignment and avoid overstressing guides.

- B. Sound Isolation: Mount rotating and vibrating equipment on vibration-isolating mounts to minimize vibration transmission to structure and structure-borne noise from elevator system.
- C. Lubricate operating parts of systems as recommended by manufacturers.
- D. Alignment: Coordinate installation of hoistway entrances with installation of elevator guide rails for accurate alignment of entrances with car. Reduce clearances to minimum, safe, workable dimension at each landing.
- E. Leveling Tolerance: 1/4 inch (6 mm), up or down, regardless of load and direction of travel.
- F. Set sills flush with finished floor surface at landing.
- G. Locate hall lanterns either above or beside hoistway entrance at a minimum of 72 inches (1829 mm) above finished floor unless hall lanterns are built into entrance frames.

3.2 FIELD QUALITY CONTROL

- A. Acceptance Testing: On completion of elevator installation and before permitting elevator use, perform acceptance tests as required and recommended by ASME A17.1/CSA B44 and by authorities having jurisdiction.

3.3 MAINTENANCE SERVICE

- A. Initial Maintenance Service: Beginning at Substantial Completion, maintenance service shall include six months' full maintenance by skilled employees of elevator Installer. Include monthly preventive maintenance, repair or replacement of worn or defective components, lubrication, cleaning, and adjusting as required for proper elevator operation. Parts and supplies shall be manufacturer's authorized replacement parts and supplies.

END OF SECTION 142600

SECTION 21 0000 - FIRE SUPPRESSION BASIC REQUIREMENTS

PART 1 - GENERAL

1.1 DESIGN-BUILD SUMMARY OF WORK

- A. Work included in 21 00 00 applies to Division 21, Fire Suppression work to provide materials, labor, tools, permits and incidentals to make fire suppression systems ready for Owner's use for proposed project.

1.2 DESIGN-BUILD INSTRUCTIONS

- A. This document is issued to give Bidders a basis for preparing a proposal to design and install a complete Fire Suppression system for this project.
- B. Alternates to this Document may be offered as a separate proposal.

1.3 DESIGN-BUILD DESIGN APPROACH

- A. Use this Specification as a guide for design/engineering requirements, workmanship and materials or construction. Utilize design-build concept throughout construction phase of project.
- B. Investigate and be apprised of applicable codes, rules, and regulations as enforced by AHJ.
- C. Visit the Site of the proposed construction. Verify and inspect the existing site to determine conditions that affect this work.

1.4 DESIGN-BUILD DESIGN CRITERIA/CALCULATIONS

- A. Related Work Specified Elsewhere:
 - 1. Contents of Section apply to Division 21, Fire Suppression Specifications.
 - 2. Requirements of Section are a minimum for Division 21, Fire Suppression Sections, unless otherwise stated in each Section, in which case that Section's requirements take precedence.
- B. Fire Suppression Design Criteria: Refer to individual Division 21, Fire Suppression Sections for fire suppression system design criteria.
- C. Fire Suppression Equipment: Refer to individual Division 21, Fire Suppression Sections for fire suppression equipment requirements.

1.5 SECTION INCLUDES

- A. Work included in 21 00 00, Fire Suppression Basic Requirements applies to Division 21, Fire Suppression work to provide materials, labor, tools, permits, incidentals, and other services to provide and make ready for Owner's use of fire protection systems for proposed project.
- B. Contract Documents include, but are not limited to, Specifications including Division 00, Procurement and Contracting Requirements and Division 01, General Requirements, Drawings, Addenda, Owner/Architect Agreement, and Owner/Contractor Agreement. Confirm requirements before commencement of work.

- C. Definitions:
1. Provide: To furnish and install, complete and ready for intended use.
 2. Furnish: Supply and deliver to project site, ready for unpacking, assembly and installation.
 3. Install: Includes unloading, unpacking, assembling, erecting, installation, applying, finishing, protecting, cleaning and similar operations at project site as required to complete Item of work furnished.
 4. Approved or Approved Equivalent: To possess the same performance qualities and characteristics and fulfill the utilitarian function without any decrease in quality, durability or longevity. For equipment/products defined by the Contractor as "equivalent," substitution requests must be submitted to Engineer for consideration, in accordance with Division 01, General Requirements, and approved by the Engineer prior to submitting bids for substituted Item.
 5. Authority Having Jurisdiction (AHJ): Indicates reviewing authorities, including local fire marshal, Owner's insurance underwriter, Owner's Authorized Representative, and other reviewing entity whose approval is required to obtain systems acceptance.

1.6 RELATED SECTIONS

- A. Content of Section applies to Division 21, Fire Suppression Contract Documents.
- B. Related Work:
1. Additional conditions apply to this Division including, but not limited to:
 - a. Specifications including Division 00, Procurement and Contracting Requirements and Division 01, General Requirements.
 - b. Drawings
 - c. Addenda
 - d. Owner/Architect Agreement
 - e. Owner/Contractor Agreement
 - f. Codes, Standards, Public Ordinances and Permits

1.7 REFERENCES AND STANDARDS

- A. References and Standards per Division 00, Procurement and Contracting Requirements and Division 01, General Requirements, individual Division 21, Fire Suppression Sections and those listed in this Section.
- B. Codes to include latest adopted editions, including current amendments, supplements and local jurisdiction requirements in effect as of the date of the Contract Documents, of/from:
1. State of Virginia:
 - a. 2012 International Building Code (IBC) with corresponding Virginia Construction Code Supplement
 - b. 2012 International Mechanical Code (IMC) with corresponding Virginia Construction Code Supplement
 - c. 2012 International Plumbing Code (IPC) with corresponding Virginia Construction Code Supplement
 - d. 2012 International Fuel Gas Code (IFGC) with corresponding Virginia Construction Code Supplement

- e. 2012 National Electric Code (NFPA 70-2011) with corresponding Virginia Construction Code Supplement
 - f. 2012 International Energy Conservation Code (IECC) with corresponding Virginia Construction Code Supplement
- C. Reference standards and guidelines include but are not limited to the latest adopted editions from:
1. ABA - Architectural Barriers Act
 2. ADA - Americans with Disabilities Act
 3. AHRI - Air-Conditioning Heating & Refrigeration Institute
 4. ANSI - American National Standards Institute
 5. ASCE - American Society of Civil Engineers
 6. ASCE-7 Minimum Design Loads for Buildings and Other Structures
 7. ASHRAE - American Society of Heating, Refrigerating and Air-Conditioning Engineers
 8. ASHRAE Guideline 0, the Commissioning Process
 9. ASME - American Society of Mechanical Engineers
 10. ASPE - American Society of Plumbing Engineers
 11. ASSE - American Society of Sanitary Engineering
 12. ASTM - ASTM International
 13. AWWA - American Water Works Association
 14. CFR - Code of Federal Regulations
 15. EPA - Environmental Protection Agency
 16. ETL - Electrical Testing Laboratories
 17. FCC - Federal Communications Commission
 18. FM - FM Global
 19. FM Global - FM Global Approval Guide
 20. IAPMO - International Association of Plumbing and Mechanical Officials
 21. ICC - International Code Council
 22. IEC - International Electrotechnical Commission
 23. ICC-ESR - International Code Council Evaluation Service Reports
 24. HI - Hydraulic Institute Standards
 25. ISO - International Organization for Standardization
 26. MSS - Manufacturers Standardization Society
 27. NEC - National Electric Code
 28. NEMA - National Electrical Manufacturers Association
 29. NFPA - National Fire Protection Association:
 - a. NFPA 13R - Standard for the Installation of Sprinkler Systems in Lowrise Residential Occupancies
 - b. NFPA 24 - Standard for Installation of Private Fire Service Mains and Their Appurtenances
 - c. NFPA 25 - Standard for Inspection, Testing, and Maintenance of Water-Based Fire Protection Systems
 - d. NFPA 70 - National Electrical Code
 - e. NFPA 72 - National Fire Alarm and Signaling Code
 30. NRCA - National Roofing Contractors Association
 31. NSF - National Sanitation Foundation
 32. OSHA - Occupational Safety and Health Administration
 33. SMACNA - Sheet Metal and Air Conditioning Contractors' National Association, Inc.
 34. TIMA - Thermal Insulation Manufacturers Association

35. UL - Underwriters Laboratories Inc.

D. See Division 21, Fire Suppression individual Sections for additional references.

1.8 SUBMITTALS

A. See Division 01, General Requirements for Submittal Procedures as well as specific individual Division 21, Fire Suppression sections.

B. Provide drawings in format and software release equal to the design documents. Drawings to be the same sheet size and scale as the Contract Documents.

C. "No Exception Taken" constitutes that review is for general conformance with the design concept expressed in the Contract Documents for the limited purpose of checking for conformance with information given. Any action is subject to the requirements of the Contract Documents. Contractor is responsible for the dimensions and quantity and will confirm and correlate at the job site, fabrication processes and techniques of construction, coordination of the work with that of all other trades, and the satisfactory performance of the work.

D. Provide product submittals and shop drawings in electronic format only. Electronic format must be submitted via zip file via e-mail. For electronic format, provide one file per division containing one bookmarked PDF file with each bookmark corresponding to each Specification Section. Arrange bookmarks in ascending order of Specification Section number. Individual submittals sent piecemeal in a per Specification Section method will be returned without review or comment. Copy Architect on all transmissions/submissions.

E. Submit shop drawings, calculations and product data sheets as one complete stand-alone package to AHJ, Owner's insurance underwriter and Engineer.

F. Product Data: Provide Manufacturer's descriptive literature for products specified in Division 21, Fire Suppression Sections.

G. Identify/mark each submittal in detail. Note what differences, if any, exist between the submitted item and the specified item. Failure to identify the differences will be considered cause for disapproval. If differences are not identified and/or not discovered during the submittal review process, Contractor remains responsible for providing equipment and materials that meet the Specifications and Drawings.

1. Label submittal to match numbering/references as shown in Contract Documents. Highlight and label applicable information to individual equipment or cross out/remove extraneous data not applicable to submitted model. Clearly note options and accessories to be provided, including field installed Item. Highlight connections by/to other trades.
2. Include technical data, installation instructions and dimensioned drawings for products, equipment and devices installed, furnished or provided. Reference Division 21, Fire Suppression specification Sections for specific Item required in product data submittal outside of these requirements.
3. Provide pump curves, operation characteristics, capacities, ambient noise criteria, etc. for equipment.
4. For vibration isolation of equipment, list make and model selected with operating load and deflection. Indicate frame type where required. Submit manufacturer's product data.
5. See Division 21, Fire Suppression Sections for additional submittal requirements outside of these requirements.

- H. Maximum of two reviews provided of complete submittal package. Arrange for additional reviews and/or early review of long-lead Item; Bear costs of additional reviews at Engineer's hourly rates. Incomplete submittal packages/submittals will be returned to contractor without review.
- I. Resubmission Requirements: Make corrections or changes in submittals as required, and in consideration of Engineer's comments. Identify Engineer's comments and provide an individual response to each of the Engineer's comments. Cloud changes in the submittals and further identify changes which are in response to Engineer's comments.
- J. Trade Coordination: Include physical characteristics, electrical characteristics, device layout plans, wiring diagrams, and connections as required per Division 21, Fire Suppression coordination documents. For equipment with electrical connections, furnish copy of approved submittal for inclusion in Division 26, Electrical and Division 28, Electronic Safety submittals.
- K. Make provisions for openings in building for admittance of equipment prior to start of construction or ordering of equipment.
- L. Substitutions and Variation from Basis of Design:
 - 1. The Basis of Design designated product establishes the qualities and characteristics for the evaluation of any comparable products by other listed acceptable manufacturers if included in this Specification or included in an approved Substitution Request as judged by the Design Professional.
 - 2. If substitutions and/or equivalent equipment/products are being proposed, it is the responsibility of parties concerned, involved in, and furnishing the substitute and/or equivalent equipment to verify and compare the characteristics and requirements of that furnished to that specified and/or shown. If greater capacity and/or more materials and/or more labor is required for the rough-in, circuitry or connections than for the item specified and provided for, then provide compensation for additional charges required for the proper rough-in, circuitry and connections for the equipment being furnished. No additional charges above the Base Bid, including resulting charges for work performed under other Divisions, will be allowed for such revisions. Coordinate with the requirements of "Submittals". For any product marked "or approved equivalent", a substitution request must be submitted to Engineer for approval prior to purchase, delivery or installation.
- M. Shop Drawings:
 - 1. Provide coordinated Shop Drawings which include physical characteristics of all systems, equipment and piping layout, pipe layout, hanger layout, drains, location of drain discharge, risers, valves, details, water test information, physical device layout plans, and control wiring diagrams. Reference individual Division 21, Fire Suppression Sections for additional requirements for shop drawings outside of these requirements.
 - 2. Shop Drawings and hydraulics calculations, sway brace calculations, trapeze hanger calculations, and the like, to be prepared under the direct supervision and control of a Professional Engineer competent to do such work and licensed in the state of Virginia. Drawings and calculations to bear the seal and wet signature of the professional Engineer.
 - 3. Provide Shop Drawings which indicate information required by NFPA 13. Include room names and fire sprinkler occupancy hazard classifications.

4. Provide Shop Drawings illustrating information for Hydraulic Information Sign for each hydraulic remote area calculated.
 5. Utilizing the Reflected Ceiling backgrounds, provide Shop Drawings illustrating locations of fire sprinklers and piping.
 6. Utilizing the Structural backgrounds, provide Shop Drawings illustrating locations and types of hangers and sway braces.
 7. Provide Shop Drawings illustrating each type of hanger, including fasteners to structure.
 8. Provide Shop Drawings illustrating each type of branchline restraint and sway brace, including length of sway brace member, sway brace fittings, minimum and maximum angles from vertical of sway brace member, method of attachment to structure, size, length and embedment of attachment to structure and size and type of structural member to which sway brace will be attached. Number each type of restraint and sway brace. Indicate on Drawings locations of each type of numbered restraint and sway brace.
 9. Provide details for any hanger, attachment, or sway brace to be attached to any I-joist, structural insulated panels (SIPs), cross laminated timber, and similar engineered structural products according to the specifications of the engineered product manufacturer.
 10. Provide Shop Drawings illustrating information for Sprinkler System General Information Sign.
 11. Shop Drawings to include a cross-sectional view that shows the sprinkler heads and piping in relation to the building's architectural and structural information. View to be chosen based on a location that will display the most information.
 12. When required, provide Coordination Drawings.
 13. Provide Shop Drawings indicating access panel locations, size and elevation for approval prior to installation.
 14. Provide details of hanger, sway bracing and branch line restraint attachments to structure and to piping. Include details on the size and load capacities of fasteners. Provide verification of the structural capacity to withstand seismic load.
 15. Clearly indicate the elevation of the highest sprinkler in relation to the elevation of the flow test pressure gauge monitor hydrant.
 16. Provide details of flexible sprinkler hose fitting per manufacturer's schedule of equivalent feet used in hydraulic calculations, showing device length, maximum number of 90-degree bends and expected radius of bends.
 17. Provide a schedule of signage to be installed at each flexible sprinkler hose fitting.
 18. On the drawings, provide a list of number, model, temperature, sprinkler Identification number, manufacturer, orifice, deflector type, thermal sensitivity and pressure rating, quantity of each type to be contained in the spare sprinkler cabinet and the issue date or revision date of the list."
 19. Spare sprinkler head cabinet size indicating the number of spare sprinkler head to be contained therein.
- N. Samples: Provide samples when requested by individual Sections.
- O. Resubmission Requirements:
1. Make any corrections or change in submittals when required. Provide submittals as specified. The Engineer will not be required to edit and/or interpret the Contractor's submittals. Indicate changes for the resubmittal in a cover letter with reference to page(s) changed and reference response to comment. Clearly indicate changes on Drawings and cloud changes in the submittals.

2. Resubmit for review until review indicates no exceptions taken or make "corrections as noted".
- P. Operation and Maintenance Manuals/Owner's Instructions:
1. Submit, at one time, electronic files (PDF format) of manufacturer's operation and maintenance instruction manuals and parts lists for equipment or Item requiring servicing. Include valve charts. Submit data when work is substantially complete and in same order format as submittals. Include name and location of source parts and service for each piece of equipment.
 - a. Include copies of certificates of code authority acceptance, code-required acceptance tests; test reports and certificates.
 - b. Include Warranty per Division 00, Procurement and Contracting Requirements and Division 01, General Requirements, Section 21 00 00, Fire Suppression Basic Requirements and individual Sections.
 - c. Catalog description of each Item of equipment actually installed on job.
 - d. Instructions for operation and maintenance of fire suppression systems composed of operating instructions, maintenance instructions and manufacturer's literature as follows:
 - 1) Testing and Maintenance Schedule Chart: Provide an 8-1/2- by 11-inch typewritten list of each item of installed equipment requiring testing inspection , lubrication or service, describing and scheduling performance of maintenance.
 - 2) Manufacturer's Literature: Provide copies of manufacturer's instructions for operation and maintenance of fire suppression equipment, including replacement parts list with name and address of nearest distributor. Mark each copy with equipment identification label as listed in equipment schedule, i.e. F-5 etc.
 - e. Include product certificates of warranties and guarantees.
 - f. Include Record Drawings,
 - g. Include copy of water supply flow test used as basis for hydraulic calculations.
 - h. Include hydraulic calculations and sway brace calculations.
 - i. Include Contractor's Material and Test Certificates for Aboveground Piping/Underground Piping.
 - j. Include a copy of NFPA 25.
 - k. Include a copy of valve charts and whether normally open or normally closed.
 - l. Include a copy of drain, auxiliary, and low point drains charts.
 - m. Include a copy of the list to be included in the spare sprinkler head box.
 - n. Include copy of approved submittal data along with submittal review letters received from Engineer. Data to clearly indicate installed equipment model numbers. Delete or cross out data pertaining to other equipment not specific to this project.
 - o. Include copy of manufacturer's standard Operations and Maintenance for equipment. At front of each tab, provide routine maintenance documentation for scheduled equipment. Include manufacturer's recommended maintenance schedule and highlight maintenance required to maintain warranty. Furnish list of routine maintenance parts, including part numbers, sizes, and quantities relevant to each piece of equipment: i.e. belts, motors, lubricants, and filters.
 - p. Include copy of complete parts list for equipment. Include available exploded views of assemblies and sub-assemblies.
 - q. Include copy of startup and test reports specific to each piece of equipment.

- r. Engineer will return incomplete documentation without review. Engineer will provide one set of review comments in Submittal Review format. Contractor must arrange for additional reviews; Contractor to bear costs for additional reviews at Engineer's hourly rates.
2. Thoroughly instruct Owner in proper operation of equipment and systems. Where noted in individual Sections, training will include classroom instruction with applicable training aids and systems demonstrations. Field instruction per Section 21 00 00, Fire Suppression Basic Requirements, Article titled "Demonstration".
3. Copies of certificates of code authority inspections, acceptance, code required acceptance tests, letter of conformance and other special guarantees, certificates of warranties, specified elsewhere or indicated on Drawings.

Q. Record Drawings:

1. Maintain at site at least one set of Drawings for recording "As-constructed" conditions. Indicate on Drawings changes to original documents by referencing revision document, and include buried elements, location of cleanouts, and location of concealed mechanical Item. Include items changed by field orders, supplemental instructions, and constructed conditions.
2. Record Drawings are to include equipment and fixture/connection schedules that accurately reflect "as constructed or installed" for project.
3. At completion of project, input changes to original project on Revit Model and make one set of black-line drawings created from Revit Model in version/release equal to contract drawings. Submit Revit disk and drawings upon substantial completion.
4. Invert elevations and dimensioned locations for water services and drainage piping below grade extending to 5-feet outside building line.
5. Record Drawings to include site information or reference site information for complete understanding of the fire protection system between the building and the point of connection to the water supply and location of flow test pressure hydrants.
6. See Division 21, Fire Suppression individual Sections for additional items to include in Record Drawings.

R. Calculations: Submit hydraulic and the like calculations.

1. Hydraulic Calculations:
 - a. Include friction losses between the hydraulically most remote design area and the hydrant flow test pressure hydrant.
 - b. Hydraulic calculations to be performed on a nationally recognized fire sprinkler hydraulic calculation computer program, with cover sheets in the format required by the latest edition of NFPA 13. Hydraulic calculations performed "by hand" or not on a nationally recognized fire sprinkler hydraulic calculations computer program will be returned without review by engineer.
 - c. Provide one or more hydraulic calculations for each hydraulically most remote area.
 - d. Where it is not obvious which area is most hydraulically remote, perform and submit for review additional hydraulic calculations proving the hydraulically most remote area.
 - e. For grid systems, either provide "peaked" hydraulic calculations, or provide two additional sets of hydraulic calculations for each hydraulically most remote area.
 - f. Include pressure losses between the highest sprinkler and the elevation of the pressure gauge monitor hydrant of the flow test.

- g. Include friction loss for flexible branch line connectors per manufacturer's schedule of equivalent feet for device length, maximum number of bends and expected radius of bends.
- h. When flexible sprinkler hose fittings are added to an existing system, provide hydraulic calculations verifying the design flow rate will be achieved."
- i. For Future Tenant Improvement Spaces: Include in hydraulic calculations friction loss allowances for future installation of flexible sprinkler head connectors so that flexible connectors may be installed in the future without revisions to the overhead system.

1.9 QUALITY ASSURANCE

- A. Regulatory Requirements: Work and materials installed to conform with all local, State and Federal codes, and other applicable laws and regulations. Where code requirements are at variance with Contract Documents, meet code requirements as a minimum requirement and include costs necessary to meet these in Contract. Machinery and equipment are to comply with OSHA requirements, as currently revised and interpreted for equipment manufacturer requirements. Install equipment provided per manufacturer recommendations.
- B. Whenever this Specification calls for material, workmanship, arrangement or construction of higher quality and/or capacity than that required by governing codes, higher quality and/or capacity take precedence.
- C. Drawings are intended to be diagrammatic and reflect the Basis of Design manufacturer's equipment. They are not intended to show every Item in its exact dimensions, or details of equipment or proposed systems layout. Verify actual dimensions of systems (i.e., piping) and equipment proposed to assure that systems and equipment will fit in available space. Contractor is responsible for design and construction costs incurred for equipment other than Basis of Design, including, but not limited to, architectural, structural, electrical, HVAC, fire sprinkler, and plumbing systems.
- D. Manufacturer's Instructions: Follow manufacturer's written instructions. If in conflict with Contract Documents, obtain clarification. Notify Engineer/Architect, in writing, before starting work.
- E. Items shown on Drawings are not necessarily included in Specifications or vice versa. Confirm requirements in all Contract Documents.
- F. Provide products that are UL listed.
- G. Piping Insulation products to contain less than 0.1 percent by weight PBDE in all insulating materials.

1.10 WARRANTY

- A. Provide written warranty covering the work for a period of one year from date of Substantial Completion in accordance with Division 00, Procurement and Contracting Requirements and Division 01, General Requirements, Section 21 00 00, Fire Suppression Basic Requirements and individual Division 21, Fire Suppression Sections.

- B. Sections under this Division can require additional and/or extended warranties that apply beyond basic warranty under Division 01, General Requirements and the General Conditions. Confirm requirements in all Contract Documents.

1.11 COORDINATION DOCUMENTS

- A. Prior to construction, coordinate installation and location of HVAC equipment, ductwork, grilles, diffusers, piping, plumbing equipment/fixtures, fire sprinklers, fire alarm, plumbing, cable trays, lights, and electrical services with architectural and structural requirements, and other trades (including fire alarm ceiling suspension and tile systems), and provide maintenance access requirements. Coordinate with submitted architectural systems (i.e. roofing, ceiling, and finishes) and structural systems as submitted, including footings and foundation. Identify zone of influence from footings and ensure systems are not routed within the zone of influence.
- B. Advise Architect in the event a conflict occurs in location or connection of equipment. Bear costs resulting from failure to properly coordinate installation or failure to advise Architect of conflict.
- C. Verify in field exact size, location, invert, and clearances regarding existing material, equipment and apparatus, and advise Architect of discrepancies between that indicated on Drawings and that existing in field prior to installation.
- D. Submit final Coordination Drawings with changes as Record Drawings at completion of project.

1.12 VIRIDIANT REQUIREMENTS

- A. Project seeks Net-Zero ready, as outlined by Viridiant's Residential Net-Zero program.
- B. Obtain list of credits sought by project. Be familiar with requirements for credits. See Division 00, Procurement and Contracting Requirements and Division 01, General Requirements for requirements.
- C. Provide materials and services as outlined in appropriate Viridiant Residential Net-Zero Reference Guide.
- D. Provide documentation as outlined in appropriate Viridiant Residential Net-Zero Reference Guide.
- E. Coordinate start-up, testing, training, and installation with Commissioning Agent as required to meet commissioning requirements.
- F. Provide adequate schedule for construction activities such as building flush out.

PART 2 - PRODUCTS

2.1 MANUFACTURERS

- A. Articles, fixtures, and equipment of a kind to be standard product of one manufacturer, including but not limited to sprinkler heads, pipe, fittings, hangers and bracing materials.

2.2 STANDARDS OF MATERIALS AND WORKMANSHIP

- A. Base contract upon furnishing materials as specified. Materials, equipment, and fixtures used for construction are to be new, latest products as listed in manufacturer's printed catalog data and are to be UL, ETL, FM, and ICC-ES approved for their intended fire protection function or have adequate approval or be acceptable by State, County, and City authorities.
- B. Names and manufacturer's names denote character and quality of equipment desired and are not to be construed as limiting competition.
- C. Hazardous Materials:
 - 1. Comply with local, State of Virginia, and Federal regulations relating to hazardous materials.
 - 2. Comply with Division 00, Procurement and Contracting Requirements and Division 01, General Requirements for this project relating to hazardous materials.
 - 3. Do not use any materials containing a hazardous substance. If hazardous materials are encountered, do not disturb; immediately notify Owner and Architect. Hazardous materials will be removed by Owner under separate contract.

PART 3 - EXECUTION

3.1 ACCESSIBILITY AND INSTALLATION

- A. Confirm Accessibility and Installation requirements in Division 00, Procurement and Contracting Requirements, Division 01, General Requirements, Section 21 00 00, Fire Suppression Basic Requirements and individual Division 21, Fire Suppression Sections.
- B. Install equipment requiring access (i.e. drains, control operators, valves, motors, engines, pumps, controllers, air compressors, gauges, fill cups, tanks, cleanouts and the like) so that they may be serviced, reset, replaced or recalibrated by service people with normal service tools and equipment. Do not install equipment in obvious passageways, doorways, scuttles or crawlspaces which would impede or block intended usage.
- C. Install equipment and products complete as directed by manufacturer's installation instructions. Obtain installation instructions from manufacturer prior to rough-in of equipment and examine instructions thoroughly. When requirements of installation instructions conflict with Contract Documents, request clarification from Architect prior to proceeding with installation. This includes proper installation methods, sequencing, and coordination with other trades and disciplines.
- D. Earthwork:
 - 1. Confirm Earthwork requirements in Contract Documents. In absence of specific requirements, comply with the following:
 - a. Perform excavation, dewatering, shoring, bedding, and backfill required for installation of work in this Division in accordance with the provisions specified. Contact utilities and locate existing utilities prior to excavation. Repair any work damaged during excavation or backfilling.
 - b. Excavation: Do not excavate under footings, foundation bases, or retaining walls.

- c. Provide protection of underground systems. Review the project Geotechnical Report for references to corrosive or deleterious soils which will reduce the performance or service life of underground systems materials.
- E. Firestopping:
1. Confirm Firestopping requirements in Division 07, Thermal and Moisture Protection.
 2. In absence of specific requirements, comply with individual Division 21, Fire Suppression Sections and coordinate location and protection level of fire and/or smoke rated walls, ceilings, and floors. When these assemblies are penetrated, seal around piping, ductwork and equipment with approved firestopping material. Install firestopping material complete as directed by manufacturer's installation instructions. Meet requirements of ASTM International E814, Standard Test Method for Fire Tests of Through-Penetration Fire Stops.
- F. Pipe Installation:
1. Provide installation of piping systems coordinated to account for expansion and contraction of piping materials and building as well as anticipated settlement or shrinkage of building. Install work to prevent damage to piping, equipment, and building and its contents. Provide piping offsets, loops, expansion joints, sleeves, anchors or other means to control pipe movement and minimize forces on piping. Verify anticipated settlement and/or shrinkage of building with Project Structural Engineer. Verify construction phasing, type of building construction products and rating coordinating installation of piping systems.
 2. Include provisions for servicing and removal of equipment without dismantling piping.
- G. Plenums: Provide plenum rated materials that meet the requirements to be installed in plenums. Immediately notify Architect/Engineer of discrepancy.
- ### 3.2 REVIEW AND OBSERVATION
- A. Confirm Review and Observation requirements in Division 00, Procurement and Contracting Requirements and Division 01, General Requirements, Section 21 00 00, Fire Suppression Basic Requirements and individual Division 21, Fire Suppression Sections.
- B. Notify Architect, in writing, at following stages of construction so that they may, at their option, visit site for review and construction observation:
1. Underground piping installation prior to backfilling.
 2. Prior to covering walls.
 3. Prior to ceiling cover/installation.
 4. When main systems, or portions of, are being tested and ready for inspection by AHJ.
 5. When mains or branchlines are to be permanently concealed by construction or insulation systems.
 6. When fire suppression systems, or portions of, are being tested and ready for inspection by AHJ.
- C. Bear responsibility and cost to make piping accessible, to expose concealed lines, or to demonstrate acceptability of the system. If Contractor fails to notify Architect at times prescribed above, costs incurred by removal of such work are the responsibility of the Contractor.

- D. Final Punch: Costs incurred by additional trips required due to incomplete systems will be the responsibility of the Contractor.

3.3 CUTTING AND PATCHING

- A. Confirm Cutting and Patching requirements in Division 01, General Requirements. In absence of specific requirements, comply with individual Division 21, Fire Suppression Sections and the following:
 - 1. Cutting and patching performed under Division 21, Fire Suppression includes, but is not limited to:
 - a. Cutting and patching of plaster or partitions.
 - b. Cutting and patching of finished ceilings.
 - 2. Perform cutting and patching by skilled craftsmen in trade of work to be performed. Fill holes which are cut oversized for completed work. Match refinished areas with existing adjacent finish in a manner acceptable to Architect.
 - 3. When masonry to concrete construction must be penetrated, provide a steel pipe sleeve in opening and grout in place in a neat manner. Leave grout surface to match existing finish. Provide escutcheons. If sleeves are not provided, core drill penetrations.
 - 4. Locate concealed utilities to eliminate possible service interruption or damage.
 - 5. Additional work required by lack of proper coordination will be provided at no additional cost to the Owner.
 - 6. Proposed floor cutting/core drilling/sleeve locations to be approved by Project Structural Engineer. Submit proposed locations to Architect/Project Structural Engineer. Where slabs are of post tension construction, perform x-ray scan of proposed penetration locations and submit scan results including proposed penetration locations to Project Structural Engineer/Architect for approval. Where slabs are of waffle type construction, show column cap extent and cell locations relative to proposed penetration(s).
 - 7. Cutting, patching and repairing for work specified in this Division including plastering, masonry work, concrete work, carpentry work, and painting included under this Section will be performed by skilled craftsmen of each respective trade in conformance with appropriate Division of Work.
 - 8. Additional openings required in building construction to be made by drilling or cutting. Use of jack hammer is specifically prohibited. Patch openings in and through concrete and masonry with grout.
 - 9. Restore new or existing work that is cut and/or damaged to original condition. Patch and repair specifically where existing items have been removed. This includes repairing and painting walls, ceilings, etc. where existing conduit and devices are removed as part of this project. Where alterations disturb lawns, landscaping, paving, and walks, surfaces to be repaired, refinished and left in condition matching existing prior to commencement of work.
 - 10. Repair mutilation of building around pipes, equipment, hangers, and braces.

3.4 EQUIPMENT SELECTION AND SERVICEABILITY

- A. Replace or reposition equipment which is too large or located incorrectly to permit servicing at no additional cost to Owner.

3.5 DELIVERY, STORAGE AND HANDLING

- A. Confirm requirements in Division 00, Procurement and Contracting Requirements and Division 01, General Requirements. In absence of specific requirements, comply with individual Division 21, Fire Suppression Sections and the following:
 - 1. Handle materials delivered to project site with care to avoid damage and deterioration. Store materials in original containers which identify manufacturer, name, brand and model numbers on site inside building or protected from weather, sun, dirt and construction dust. Insulation and lining that becomes wet from improper storage and handling to be replaced before installation. Products and/or materials that become damaged due to water, dirt and/or dust as a result of improper storage to be replaced before installation.
 - 2. Protect equipment and pipe to avoid damage. Close pipe openings with caps or plugs. Keep motors and bearings in watertight and dustproof covers during entire course of installation.
 - 3. Protect bright finished shafts, bearing housings and similar Item until in service.

3.6 DEMONSTRATION

- A. Confirm Demonstration requirements in Division 00, Procurement and Contracting Requirements and Division 01, General Requirements, Section 21 00 00, Fire Suppression Basic Requirements and individual Division 21, Fire Suppression Sections.
- B. Upon completion of work and adjustment of equipment and test systems, demonstrate to Owner's Authorized Representative, Architect and Engineer that equipment furnished and installed or connected under provisions of these Specifications functions in manner required. Provide field instruction to Owner's Maintenance Staff as specified in Division 01, General Requirements, Section 21 00 00, Fire Suppression Basic Requirements and individual Division 21, Fire Suppression Sections.
- C. Manufacturer's Field Services: Furnish services of a qualified person at time approved by Owner to instruct maintenance personnel, correct defects or deficiencies, and demonstrate to satisfaction of Owner that entire system is operating in satisfactory manner and complies with requirements of other trades that may be required to complete work. Complete instruction and demonstration prior to final job site observations.
- D. Prior to acceptance of work and during time designated by Architect, provide necessary qualified personnel to operate system for a period of two hours.
- E. Instruct the Owner in the operation of the sprinkler system, including main valve position (open or closed) recognition, system drainage, system testing, dry pipe valve reset and the relation to the fire alarm system.
- F. Upon completion of work and adjustment of equipment, test systems to demonstrate to Owner's Authorized Representative and Architect that equipment is furnished and installed or connected under provisions of these Specifications.

3.7 CLEANING

- A. Confirm Cleaning requirements in Division 00, Procurement and Contracting Requirements and Division 01, General Requirements, Section 21 00 00, Fire Suppression Basic Requirements and individual Division 21, Fire Suppression Sections.
- B. Upon completion of installation, except for sprinklers, thoroughly clean exposed portions of equipment, removing temporary labels and traces of foreign substances. Throughout work, remove construction debris and surplus materials accumulated during work.
- C. Sprinklers may not be cleaned except for vacuuming in a manner in which no part of the sprinkler is touched by the vacuuming equipment. Replace sprinklers which bear traces of foreign substances with sprinklers of same model, temperature, K-factor, orifice, finish, style, orientation, and the like.

3.8 INSTALLATION

- A. Confirm Installation requirements in Division 00, Procurement and Contracting Requirements and Division 01, General Requirements, Section 21 00 00, Fire Suppression Basic Requirements and individual Division 21, Fire Suppression Sections.
- B. Install equipment in accordance with manufacturer's installation instructions, plumb and level and firmly anchored to vibration isolators. Maintain manufacturer's recommended clearances.
- C. Start-up equipment, in accordance with manufacturer's start-up instructions, in the presence of manufacturer's representative. Test controls and demonstrate compliance with requirements. Replace damaged or malfunctioning controls and equipment. Provide pump impellers to obtain Basis of Design design capacities.
- D. Provide miscellaneous supports/metals required for installation of equipment and piping.

3.9 PAINTING

- A. Confirm requirements in Division 01, General Requirements and Division 09, Finishes. In absence of specific requirements, comply with individual Division 21, Fire Suppression Sections and the following:
 - 1. Ferrous Metal: After completion of fire protection work, thoroughly clean and paint exposed supports constructed of ferrous metal surfaces, i.e., hangers, hanger rods, equipment stands, with one coat of black asphalt varnish for exterior or black enamel for interior, suitable for hot surfaces.
 - 2. After acceptance by Authority Having Jurisdiction (AHJ), in a mechanical room, on roof or other exposed areas, machinery and equipment not painted with enamel to receive two coats of primer and one coat of rustproof enamel, colors as selected by Architect.
 - 3. Structural Steel: Repair damage to structural steel finishes or finishes of other materials damaged by cutting, welding or patching to match original.
 - 4. Piping: Clean, primer coat and paint exposed piping on roof or at other exterior locations with two coats paint suitable for metallic surfaces and exterior exposures. Color selected by Architect.
 - 5. Covers: Covers such as vault covers and the like will be furnished with finishes which resist corrosion and rust.

3.10 ACCEPTANCE

- A. Confirm requirements in Division 00, Procurement and Contracting Requirements and Division 01, General Requirements. In absence of specific requirements, comply with individual Sections in Division 21, Fire Suppression and the following:
 - 1. System cannot be considered for acceptance until work is completed and demonstrated to Architect that installation is in strict compliance with Specifications, Drawings and manufacturer's installation instructions, particularly in reference to following:
 - a. Testing reports including Contractor's Material and Test Certificate for Underground Piping, Contractor's Material and Test Certificate for Aboveground Piping, Contractor's Material and Test Certificate for Private Fire Service Mains, Fire pump acceptance test data report, and the like.
 - b. Cleaning
 - c. Operation and Maintenance Manuals
 - d. Training of Operating Personnel
 - e. Record Drawings
 - f. Warranty and Guaranty Certificates
 - g. Start-up/Test Document and Commissioning Reports
 - h. Letter of Conformance

3.11 FIELD QUALITY CONTROL

- A. Confirm Field Quality Control requirements in Division 00, Procurement and Contracting Requirements and Division 01, General Requirements, Section 21 00 00, Fire Suppression Basic Requirements and individual Division 21, Fire Suppression Sections.
- B. Upon completion of installation of equipment, sprinklers, hose valves and piping and after units are water pressurized, test system to demonstrate capability and compliance with requirements. When possible, correct malfunctioning Item at site, then retest to demonstrate compliance; otherwise remove and replace with new Item and proceed with retesting.
- C. Inspect each installed Item for damage to finish. If feasible, restore and match finish to original, except fire sprinklers, at site; otherwise, remove Item and replace with new Item. Feasibility and match to be judged by Architect. Remove cracked or dented Item and replace with new Item.
- D. Fire sprinklers may not be reused, or cleaned, except for dusting. Replace damaged, field painted, oversprayed, overcoated or field coated sprinklers with new sprinklers of same manufacturer, model, finish, K-factor and performance characteristics. Where identical replacement sprinklers are not available, provide sprinklers of similar finish, style, K-factor and performance characteristics.

3.12 LETTER OF CONFORMANCE

- A. Provide Letter of Conformance and copies of manufacturers' warranties and extended warranties with a statement that fire suppression items were installed in accordance with manufacturer's recommendations, UL listings and FM Global approvals. Include Letter of Conformance, copies of manufacturers' warranties and extended warranties in Operation and Maintenance Manuals.

3.13 ELECTRICAL INTERLOCKS

- A. Where equipment motors are to be electrically interlocked with other equipment for simultaneous operation, utilize fire protection equipment wiring diagrams to coordinate with electrical systems so that proper wiring of equipment involved is affected.

3.14 CONNECTIONS TO EXISTING

- A. Prior to connection of piping to existing piping or utilities, field verify existing conditions and exact sizes and locations of existing piping. Provide additional offsets, transitions, joints, cut-ins, and replace portions of existing as required to facilitate connections of new.

END OF SECTION

SECTION 21 0500 - COMMON WORK RESULTS FOR FIRE SUPPRESSION

PART 1 - GENERAL

1.1 SUMMARY

A. Work Included:

1. Buried Ductile Iron Pipe and Fittings
2. Joint Restraints
3. Aboveground Black Steel Pipe and Fittings
4. Wall and Floor Penetrations and Sleeves
5. Switches, Valve Supervisory
6. Switches, Water Detector
7. Hangers and Supports
8. Struts and Strut Clamps
9. Anchors and Attachments
10. Pipe Stands
11. Gauges
12. Bells
13. Fire Department Connection
14. Valves
15. Backflow Prevention Devices
16. Pipe, Valve, and Fire Protection Equipment Identification
17. Signs
18. Drains

1.2 RELATED SECTIONS

- A. Contents of Division 21, Fire Suppression and Division 01, General Requirements apply to this Section.
- B. In addition, reference the following:
 1. Division 22, Plumbing
 2. Division 23, Heating, Ventilating and Air Conditioning
 3. Division 26, Electrical
 4. Division 28, Electronic Safety
 5. Division 31, Earthwork
 6. Section 21 00 00, Fire Suppression Basic Requirements
 7. Section 21 13 00, Fire Suppression Sprinkler Systems

1.3 REFERENCES AND STANDARDS

- A. References and Standards as required by Section 21 00 00, Fire Suppression Basic Requirements and Division 01, General Requirements.
- B. Meet requirements of ASCE 7, Minimum Design Loads for Buildings and Other Structures, by American Society of Civil Engineers, latest adopted edition.

1.4 SUBMITTALS

- A. Submittals as required by Section 21 00 00, Fire Suppression Basic Requirements and Division 01, General Requirements.

1.5 QUALITY ASSURANCE

- A. Quality assurance as required by Section 21 00 00, Fire Suppression Basic Requirements and Division 01, General Requirements.
- B. In addition, meet the following:
 - 1. Material and Equipment: Listed for its intended fire protection use in current UL Fire Protection Equipment Directory, or UL Online Certifications Directory for Fire Protection, International Code Council Evaluation Service Reports, or FM Global Approval Guide. All material and equipment to be new and from a current manufacturer.
 - 2. Provide per AHJ requirements.
 - 3. References to product Specifications for materials are listed according to accepted ANSI, ASTM, ASME, AWWA and other base standards. Materials to meet latest approved versions of these standards.
 - 4. Fire Suppression Screw-Thread Connections: Comply with local fire department/fire marshal regulations for sizes, threading and arrangement of connections for fire department equipment to fire department connections.
 - 5. Manufacturers: Unless an item is marked "No substitutions", submit substitution request for materials of other than named manufacturers.
 - 6. Noise and Vibration:
 - a. Install vibration isolators and measures required to prevent noise and vibration from being transmitted to occupied areas. Select equipment to operate within noise coefficient (NC) design level for particular type of installation in relation to its location.
 - b. After installation, make proper adjustments to reduce noise and vibration to acceptable levels as defined by Architect.
 - c. In acoustically sensitive areas, design system in a manner that minimizes the number of wall penetrations.

1.6 WARRANTY

- A. Warranty of materials and workmanship as required by Section 21 00 00, Fire Suppression Basic Requirements and Division 01, General Requirements.

1.7 FLOW TEST

- A. Provide materials and labor for a new water supply test on the closest nearby fire hydrants per NFPA 13 and NFPA 291. Base hydraulic calculations on new flow test.

1.8 SYSTEM IMPAIRMENT

- A. When returning a water-based fire protection system to service after impairment or control valve closure, verify the system is in working order by performing a main drain test per NFPA 25.

PART 2 - PRODUCTS

2.1 MANUFACTURERS

- A. Buried Ductile Iron Pipe and Fittings:
 - 1. American Cast Iron Pipe Co.
 - 2. Atlantic States Cast Iron Pipe Co.
 - 3. Clow Water Systems Co.
 - 4. EBAA Iron, Inc.
 - 5. Griffin Pipe Products Co.
 - 6. McWane Cast Iron Pipe Co.
 - 7. Pacific States Cast Iron Pipe Co.
 - 8. United States Pipe & Foundry Co.
 - 9. Star Pipe Products
 - 10. Tyler Union
 - 11. Or approved equivalent.

- B. Joint Restraints:
 - 1. Star Pipe Products
 - 2. Tyler Pipe Co.
 - 3. EBAA Iron, Inc.
 - 4. Uni-Flange Corp.
 - 5. Union Foundry Co.
 - 6. United States Pipe and Foundry Co.
 - 7. Or approved equivalent.

- C. Aboveground Black Steel Pipe and Fittings:
 - 1. Pipe:
 - a. Bull Moose Tube
 - b. Wheatland Tube Co.
 - c. Youngstown Tube Co.
 - d. Tex-Tube Co.
 - e. State Pipe and Supply, Inc.
 - f. Or approved equivalent
 - 2. Fittings, Mechanical and Grooved Couplings:
 - a. Victaulic
 - b. Gruvlok
 - c. Shurjoint Piping Products Inc.
 - d. Smith-Cooper International
 - e. Tyco Fire & Building Products
 - f. Viking Corp.
 - g. Allied Rubber and Gasket Co. Inc., dba ARGCO
 - h. Anvil International
 - i. Dixon Valve & Coupling
 - j. Or approved equivalent.
 - 3. Fittings, Threaded:
 - a. Ward Mfg.
 - b. Anvil International

- c. Smith-Cooper International
- d. Aegis Technologies
- e. Or approved equivalent.
- 4. Fittings, Rubber Gasketed:
 - a. Victaulic
 - b. Anvil International
 - c. AnvilStar
 - d. EBAA Iron, Inc.
 - e. Shurjoint Piping Products, Inc.
 - f. Smith-Cooper International
 - g. Tyco Fire & Building Products
 - h. Viking Corp.
 - i. Ward Mfg.
 - j. Allied Rubber and Gasket Co. Inc., dba ARGCO
 - k. Dixon Valve & Coupling
 - l. Or approved equivalent.
- 5. Fittings, Welded:
 - a. Anvil International
 - b. Shurjoint Piping Products Inc.
 - c. Smith-Cooper International
 - d. State Pipe & Supply, Inc.
 - e. Or approved equivalent.
- 6. Fittings, Flanged:
 - a. Victaulic
 - b. United Brand Fittings
 - c. U.S. Pipe
 - d. Anvil S.P.F.
 - e. Iowa Fittings Co.
 - f. Tyco Fire Products
 - g. Or approved equivalent.
- D. Wall and Floor Penetrations and Sleeves:
 - 1. Allied Rubber and Gasket Co., Inc., dba ARGCO
 - 2. Fire Protection Products Inc. (FPPI)
 - 3. Or approved equivalent.
- E. Switches, Valve Supervisory:
 - 1. Outside Screw and Yoke Valve Supervisory Switch:
 - a. Potter Electric Signal Co.
 - b. System Sensor
 - c. Or approved equivalent.
 - 2. Post Indicator Valve (PIV) Control Valve Supervisory Switch:
 - a. Potter Electric Signal Co.
 - b. System Sensor
 - c. Or approved equivalent.
 - 3. Non-Rising Stem Valve Supervisory Switch:
 - a. Potter Electric Signal Co.
 - b. System Sensor
 - c. Or approved equivalent.

4. Ball Valve Supervisory Switch:
 - a. Potter Electric Signal Co.
 - b. System Sensor
 - c. Or approved equivalent.
 5. Angle Valve Supervisory Switch:
 - a. System Sensor
 - b. Or approved equivalent.
- F. Switches, Water Detector:
1. Water Flow Switches:
 - a. Wet Sprinkler Systems:
 - 1) Potter Electric Signal Co.
 - 2) System Sensor
 - 3) Or approved equivalent.
- G. Hangers and Supports:
1. Cooper B-Line Tolco
 2. Anvil International
 3. ITW Buildex Sammys
 4. Erico International
 5. PHD Mfg. Inc.
 6. Or approved equivalent.
- H. Struts and Strut Clamps:
1. Cooper B-Line Tolco
 2. Or approved equivalent.
- I. Anchors and Attachments:
1. Concrete:
 - a. Cast-In Place Anchors for Hangers:
 - 1) Cooper B-Line Tolco
 - 2) Erico International
 - 3) Or approved equivalent.
 - b. Cast-In Place Anchors for Braces:
 - 1) Cooper B-Line Tolco
 - 2) Anvil International
 - 3) Erico International
 - 4) Or approved equivalent.
 - c. Attachments as specified or described by structural. If not specified or described by structural, then as follows:
 - 1) Hilti
 - 2) Powers
 - 3) Simpson Strong-Tie
 - 4) DeWalt
 - 5) Or approved equivalent.
 2. Wood:
 - a. Cooper B-Line Tolco
 - b. Anvil International
 - c. Elco Construction Products

- d. Erico International
 - e. ITW Buildex Sammys
 - f. Or approved equivalent.
3. Steel:
- a. Cooper B-Line Tolco
 - b. Anvil International
 - c. Elco Construction Products
 - d. Erico International
 - e. ITW Buildex Sammys
 - f. Or approved equivalent.
- J. Pipe Stands:
- 1. Cooper B-Line Tolco
 - 2. Anvil International
 - 3. Or approved equivalent.
- K. Gauges:
- 1. Ashcroft
 - 2. US Gauge
 - 3. Brecco
 - 4. Reliable Automatic Sprinkler Co.
 - 5. Fire Protection Products, Inc. (FPPI)
 - 6. Allied Rubber and Gasket Co. Inc., dba ARGCO
 - 7. Wika Instrument Corp.
 - 8. Or approved equivalent.
- L. Bells:
- 1. Interior/Exterior Alarm Bells:
 - a. Potter
 - b. System Sensor
 - c. Or approved equivalent.
- M. Fire Department Connection:
- 1. Guardian Fire Equipment
 - 2. Fire End Croker Corp.
 - 3. Potter-Roemer
 - 4. Elkhart Brass
 - 5. Tyco Fire & Building Products
 - 6. Fire Protection Products, Inc. (FPPI)
 - 7. Or approved equivalent.
- N. Valves:
- 1. OS&Y Gate:
 - a. 175 PSI:
 - 1) Nibco
 - 2) Mueller
 - 3) Or approved equivalent.
 - b. 250 PSI:
 - 1) Victaulic

- 2) Or approved equivalent.
 - c. 350 PSI:
 - 1) Nibco
 - 2) Or approved equivalent.
 - d. 2-inches and Smaller:
 - 1) Nibco
 - 2) Or approved equivalent.
- 2. NRS Gate:
 - a. 175 PSI:
 - 1) Nibco
 - 2) Or approved equivalent.
 - b. 200 PSI:
 - 1) Mueller
 - 2) Or approved equivalent.
 - c. 250 PSI:
 - 1) Victaulic
 - 2) Or approved equivalent.
- 3. Swing Check:
 - a. Victaulic
 - b. Nibco
 - c. Mueller
 - d. Viking
 - e. Tyco
 - f. AnvilStar
 - g. Reliable
 - h. Or approved equivalent.
- 4. Butterfly Valves:
 - a. Victaulic
 - b. Nibco
 - c. Tyco
 - d. Use lug body next to pumps; Nibco.
 - e. Reliable
 - f. Or approved equivalent.
- 5. Pressure Relief:
 - a. Watts
 - b. United Brass Works
 - c. AGF
 - d. Or approved equivalent.
- 6. Automatic Ball Drip Drain Valve:
 - a. Tyco
 - b. Reliable Automatic Sprinkler Co.
 - c. Or approved equivalent.
- 7. Three-Way Gauge Valve:
 - a. Fire Protection Products Inc. (FPPI)
 - b. AGF Mfg. Inc.
 - c. Nibco
 - d. Or approved equivalent.
- 8. Automatic Air Release Valve:
 - a. Potter Electric Signal Co.

- b. Or approved equivalent.
 - 9. Ball Valve:
 - a. Victaulic
 - b. Apollo Valves
 - c. Fire Protection Products Inc. (FPPI)
 - d. Nibco
 - e. Or approved equivalent.
 - O. Backflow Prevention Devices:
 - 1. Double Check Valve Assembly:
 - a. Ames
 - b. Febco
 - c. Zurn Wilkins
 - d. Apollo Valves
 - e. Or approved equivalent.
 - P. Pipe, Valve, and Fire Protection Equipment Identification:
 - 1. Fire Protection Products, Inc. (FPPI)
 - 2. Allied Rubber and Gasket Co., Inc., dba ARGCO
 - 3. Or approved equivalent.
 - Q. Signs:
 - 1. Tyco Fire Products
 - 2. Reliable Automatic Sprinkler
 - 3. Viking Corp.
 - 4. Allied Rubber and Gasket Co., Inc., dba ARGCO
 - 5. Or approved equivalent.
 - R. Drains:
 - 1. Reference Aboveground Black Steel Pipe and Fittings.
 - 2. AGF
 - 3. Victaulic
 - 4. Or approved equivalent.
- 2.2 BURIED DUCTILE IRON PIPE AND FITTINGS
- A. Pipe:
 - 1. Thickness: Class 52 ductile iron, AWWA C151.
 - 2. Pressure: 150 psi or 10.34 bar.
 - 3. Cement mortar lined per AWWA C104, field encased with 8 mil polyethylene bag per AWWA C105. Coat all bolts, restraining rods, and the like with bitumastic prior to encasement in the polyethylene bag.
 - B. Fittings: AWWA C110, 350 psi or 24.13 bar. Cement mortar lined per AWWA C104, field encased with 8 mil polyethylene bag per AWWA C105. Coat all bolts, restraining rods, and the like with bitumastic prior to encasement in the polyethylene bag.
 - C. Fittings restrained with thrust blocks or restraining rods per NFPA 24.

- D. Underground Valves: Factory coated with powdered epoxy or equivalent corrosion resistant coating. Bolts coated with bitumastic in the field. Encase the entire valve in 8-mil polyethylene bag in accordance with AWWA C-105.
- E. Flexible Underground Expansion Joints:
 - 1. AWWA C153, AWWA C116, AWWA C105.
 - 2. Expansion joint designed and cast as an integral part of a ball and socket type flexible joint.
 - 3. Internal and external epoxy lined.
 - 4. Sealing Gasket: EPDM.
 - 5. Polyethylene sleeve.

2.3 JOINT RESTRAINTS

- A. Mechanical joint wedge action for ductile iron pipe.
- B. Gland: Ductile Iron.
- C. Wedges: Ductile iron.
- D. Full restraint pressure rating of pipe with minimum safety factor of 2:1.

2.4 ABOVEGROUND BLACK STEEL PIPE AND FITTINGS

- A. Wet Pipe Systems:
 - 1. Pipe Size 2-inch Diameter and Smaller: ASTM A53, ASTM A135, or ASTM A795; minimum of Schedule 40.
 - 2. Pipe Size 2-1/2-inch Diameter and Larger: ASTM A53, ASTM A135, or ASTM A795; minimum of Schedule 10.
 - 3. Exposed pipe 8-feet or less above finished floor: A minimum of Schedule 40.
- B. Joints:
 - 1. Threaded, flanged or bevel welded.
 - 2. Piping installed in plenums or shafts to have welded joints.
- C. Fittings:
 - 1. Threaded:
 - a. Malleable Iron: Class 150 and Class 300, ANSI B16.3.
 - b. Cast Iron: Class 125 and 250, ANSI B16.3.
 - 2. Flanged:
 - a. Cast iron; Class 125 and 250, ASME B16.1.
 - b. Raised ground face, bolt holes spot faced.
 - 3. Welded:
 - a. Carbon Steel: Long radius, standard weight or extra strong.
 - b. Factory Wrought Steel Buttweld Fittings: ASME B16.9.
 - c. Buttwelding Ends for Pipe, Valves, Flanges and Fittings: ASME B16.25.
 - d. Specification for Piping Fittings of Wrought Carbon Steel and Alloy Steel for Moderate and Elevated Temperatures: ASTM A234.
 - e. Steel Pipe Flanges and Flanged Fittings: ASME B16.5.

- f. Forged Steel Fittings, Socket Welded and Threaded: ASME B16.11.
 - 4. Mechanical Fittings and Grooved Couplings:
 - a. Couplings: UL 213, AWWA C606, ASTM A536 ductile iron or ASTM A47 malleable iron, with enamel finish and grooves or shoulders designed to accept grooved couplings. Synthetic-rubber gasket with central-cavity, pressure-responsive design and ASTM A183 carbon-steel bolts and nuts.
 - b. FM Global approved.
 - D. Anti-Microbial Coating: Factory-applied coating to inhibit corrosion from microbiological organisms.
- 2.5 WALL AND FLOOR PENETRATIONS AND SLEEVES
- A. Below Grade and High Water Table Areas: Waterproof elastomeric compound.
- 2.6 SWITCHES, VALVE SUPERVISORY
- A. Provide to mount on applicable, compatible valve (OS&Y gate, or PIV), with SPDT switches to match requirements of fire alarm system. Provide with cover tamper switch where required by AHJ.
- 2.7 SWITCHES, WATER DETECTOR
- A. Provide with cover tamper switch where required by AHJ.
 - B. Water Flow Switches:
 - 1. Vane-type; SPDT switches; electronic retard, adjustable time delay (0 to 75 seconds).
 - 2. Wet Sprinkler Systems, NFPA 13: 450 PSI, 18-feet per second, 4-10 gpm.
 - C. Pressure Operated Alarm Switches: Pressure actuated with SPDT electrical switches and adjustable time delay (0 to 75 seconds).
- 2.8 HANGERS AND SUPPORTS
- A. General: Select size of hangers and supports to exactly fit pipe size for bare piping.
 - B. Hangers: Ferrous.
 - C. Hanger Rods: Zinc electroplated carbon steel.
 - D. Finishes: Use hangers and supports with galvanized metallic coatings for piping and equipment that will not have field-applied finish.
 - E. Materials:
 - 1. Use carbon steel pipe hangers and supports, metal trapeze pipe hangers and attachments for general service applications.
 - 2. Use stainless steel hangers, rods and attachments for corrosive environment applications. Examples of corrosive environment applications include, but are not limited to: swimming pools and spas, pool and spa equipment rooms and adjacent areas, chemical rooms, kidney dialysis areas, marine and beach environments, commercial laundries and the like.

- F. Anti-Scratch Padding: Use padded hangers for piping subject to scratching.

2.9 STRUTS AND STRUT CLAMPS

- A. Electro-galvanized steel.
- B. Designed for supporting pipe runs from strut supports.
- C. Strut clamps UL listed for fire protection.
- D. Stainless steel for corrosive environment applications. Examples of corrosive environment applications include, but are not limited to: swimming pools and spas, pool and spa equipment rooms and adjacent areas, chemical rooms, kidney dialysis areas, marine and beach environments, commercial laundries and the like.

2.10 ANCHORS AND ATTACHMENTS

- A. General: Anchor supports to masonry, concrete and block walls per anchoring system manufacturer's recommendations, or as modified by project Structural Engineer.
- B. Materials:
 - 1. Ferrous.
 - 2. Stainless steel for corrosive environment applications. Examples of corrosive environment applications include, but are not limited to: swimming pools and spas, pool and spa equipment rooms and adjacent areas, chemical rooms, kidney dialysis areas, marine and beach environments, commercial laundries, and the like.
- C. Cast in Place Anchors for Hangers: Verify listing is for hangers, braces, or both.

2.11 PIPE STANDS

- A. Adjustable Pipe Saddle Support with Yoke:
 - 1. Designed to support horizontal pipe from floor stanchion.
 - 2. U-bolt and hex nuts to hold pipe securely to saddle or pipe clamp type.
 - 3. ANSI/MSS SP-69; SP-58. Type 37.
 - 4. Steel pipe with steel saddle.
- B. Base Stand:
 - 1. Steel pipe welded to steel base plate.
 - 2. Meet requirements of 12X anchor diameter hole spacing for seismic applications.

2.12 GAUGES

- A. Pressure Gauges: 3.5-inch, dial type, bronze bourdon tube or spring type, stainless steel case. 0 to 300 PSI.

2.13 BELLS

- A. Exterior Alarm Bells: Minimum weatherproof backbox, typical 90 dBA at 10-feet.

2.14 FIRE DEPARTMENT CONNECTION

- A. General:
 - 1. Thread to match fire department hardware; automatic drip connected to drain; threaded dust cap and chain of same material and finish as body.
 - 2. Provide with individual clappers.
- B. Type: Free-Standing Type
- C. Finish: Ductile Iron
- D. Inlet Size: 2-1/2-inch.
- E. Number of Inlets: Two.
- F. Outlet Size: 4-inch.
- G. Size of Pipe between Fire Department Connection and Sprinkler System: 4-inch.
- H. Drain: 3/4-inch automatic ball drip, to outside.
- I. Sign: Auto Sprinkler Fire Department Connection.

2.15 VALVES

- A. OS&Y Gate:
 - 1. 2-1/2-inches and Larger: Iron body.
 - 2. 2-inches and Smaller: Bronze body.
- B. NRS Gate:
 - 1. Iron body. Non-rising stem with indicator post.
 - 2. Underground Butterfly Valves: Telescopic barrel type.
- C. Swing Check: Iron body, rubber and bronze faced checks.
- D. Butterfly Valves: Ductile iron body with factory-installed tamper switches. Use lug body next to pumps.
- E. Pressure Relief: Bronze body, stainless steel spring.
- F. Automatic Ball Drip Drain Valve: Bronze, spring-type.
- G. Three-Way Gauge Valve: Brass; rated to 300 psi.
- H. Automatic Air-Release Valve for Wet Systems:
 - 1. Rated to 175 psi.
 - 2. Automatic float-type with shutoff mounted in a water retention pan.
 - 3. Single set 24VAC@2A for electronic supervision.
 - 4. Ball valve switch with cover tamper.

- I. Ball Valves: Brass body, brass stem; forged brass ball disc.

2.16 BACKFLOW PREVENTION DEVICES

- A. Double Check Valve Assembly:
 - 1. Two check valves in series with OS&Y gate or butterfly valves at each end.
 - 2. Provide detector if required by local utility.
 - 3. UL listed or FM Global Approved for fire suppression service as an assembly.
 - 4. Approved by local and state authorities, including project's State Department of Health for the position in which it is installed.
- B. Provide Water Bureau approved Bypass-Meter and compatible Touch-Pad. Touch-Pad unit must be accessible from right-of-way.

2.17 PIPE, VALVE, AND FIRE PROTECTION EQUIPMENT IDENTIFICATION

- A. Engraved plastic laminate or corrosion resistant metal sign or plastic equipment marker.
- B. Corrosion-resistant chain or permanent adhesive.

2.18 SIGNS

- A. Engraved plastic laminate or corrosion resistant metal sign or plastic equipment marker.
- B. Corrosion-resistant chain or permanent adhesive.

2.19 DRAINS

- A. Reference Aboveground Black Steel Pipe and Fittings.

PART 3 - EXECUTION

3.1 GENERAL INSTALLATION REQUIREMENTS

- A. Install in conformance with UL Listing, FM Approval or ICC-ES requirements and restrictions.

3.2 BURIED DUCTILE IRON PIPE AND FITTINGS

- A. Pipe Sleeves:
 - 1. Lay out work in advance of pouring concrete and furnish and set sleeves necessary to complete work.
 - 2. Floor Sleeves: Provide sleeves on pipes passing through concrete or masonry construction. Extend sleeve 1-inch above finished floor. Caulk pipes passing through floor with nonshrinking firestopping, smokestopping and water stopping grout or approved equivalent caulking compound. Caulk/seal piping passing through fire rated building assembly with UL rated assemblies.
 - 3. Wall Sleeves: Provide sleeves on pipes passing through concrete or masonry construction. Provide sleeve flush with finished face of wall. Caulk pipes passing through walls with nonshrinking caulking compound. Caulk/seal piping passing through fire-rated

building assemblies with UL Listed or FM approved fire-rated firestopping compound. Provide fire-rated assemblies per local AHJ requirements.

4. Coordinate with trades for locations of pipe sleeves in reinforced concrete and steel beams. Penetrations must be indicated on structural shop drawings. See Drawings and Specifications for specific sleeve location limitations.

B. Buried Pipe:

1. Hydraulically calculated pipe to be of sufficient size as to deliver the required flow while not exceeding a flow velocity of 15-feet per second or as required in accordance with the water department requirements, whichever is less.
2. Excavation and Backfill:
 - a. General: Perform necessary excavation and backfill required for installation of mechanical work. Repair piping or other work damaged by Contractor's operations.
 - b. Water: Keep excavations free of standing water. Re-excavate and fill back excavations damaged or softened by water or frost to original level with sand, crushed rock or other approved material at no expense to Owner.
 - c. Tests: During progress of work for compacted fill, Owner reserves right to request compaction tests made under direction of a testing laboratory.
 - d. Trench Excavation: Excavate trenches to necessary depth and width, removing rocks, unstable soil (i.e. muck, peat and the like), roots and stumps. Excavation material is classified as "base fill" and "native." Base fill excavation material consisting of placed crushed rock may be used as backfill above "Pipe Zone." Remove and dispose off site native excavation material at no expense to Owner. Adequate width of trench for proper installation of piping or conduit.
 - e. Support Foundations:
 - 1) Foundations: Excavate trenches located in unstable ground areas below elevation required for installation of piping to a depth which is determined by Architect as appropriate for conditions encountered. Place and compact approved foundation material in excavation up to "Bedding Zone." Dewatering, placement, compaction and disposal of excavated materials to conform to requirements contained in other Sections of Specifications or Drawings.
 - 2) Over-Excavations: Where trench excavation exceeds required depths, provide, place and compact suitable bedding material to proper grade or elevation at no additional cost to Owner.
 - 3) Foundation Material: Where native material has been removed, place and compact necessary foundation material to form a base for replacement of required thickness of bedding material.
 - 4) Bedding Material: Full bed site piping on sand, pea gravel or 3/4-inch minus crushed rock. Place a minimum 4-inch deep layer of sand or crushed rock on leveled trench bottom for this purpose. Remove bedding to necessary depth for piping bells and couplings to maintain contact of pipe on bedding for its entire length. Provide additional bedding in excessively wet, unstable, or solid rock trench bottom conditions as required to provide a firm foundation.
 - f. Backfilling:
 - 1) Following installation and successful completion of required tests, backfill piping in lifts.
 - (a) In "Pipe Zone," place backfill material and compact in lifts not to exceed 6-inches in depth to a height of 12-inches above top of pipe.

- Place backfill material to obtain contact with entire periphery of pipe, without disturbing or displacing pipe.
- (b) Place and compact backfill above "Pipe Zone" in layers not to exceed 12-inches in depth.
- 2) Backfill Material:
 - (a) Backfill Material in "Pipe Zone": 3/4-inch minus crushed rock, sand or pea gravel.
 - (b) Crushed rock, fill sand or other backfill material approved elsewhere in Specifications may be used above "Pipe Zone."
- g. Compaction of Trench Backfill:
 - 1) Where compaction of trench backfill material is required, use one of following methods or combination thereof:
 - (a) Mechanical tamper,
 - (b) Vibratory compacter, or
 - (c) Other approved methods appropriate to conditions encountered.
 - 2) Architect to have right to change methods and limits to better accommodate field conditions. Compaction sufficient to attain 95 percent of maximum density at optimum moisture content unless noted otherwise on Drawings or elsewhere in Specifications. Water "puddling" or "washing" is prohibited.
- C. Keep pipe openings closed by means of plugs or caps to prevent entrance of foreign matter. Protect piping and fittings against dirty water, chemicals, and mechanical damage both before and after installation. Restore to original condition or replace damaged pipe and fittings prior to final acceptance of work.

3.3 JOINT RESTRAINTS

- A. Install per manufacturer's instructions and recommendations.
- B. Reference 3.01, General Installation Requirements.

3.4 ABOVEGROUND BLACK STEEL PIPE AND FITTINGS

- A. Piping Routing:
 - 1. Route piping, except as otherwise indicated, vertically and horizontally (sloped to drain). Avoid diagonal runs wherever possible. Orient horizontal routes parallel with walls and beam lines.
 - 2. Install piping as shown or described by diagrams, details and notations on Drawings or, if not indicated, install piping to provide the shortest route which does not obstruct usable space or block access for servicing the building and its equipment.
 - 3. Install piping in concealed spaces above finished ceilings. Prior to design and installation, obtain pre-approval by Architect for exposed piping.
 - 4. In open-to-structure areas which are open to public view, route exposed piping to minimize visual impact. Obtain Architect's and Engineer's approval of exposed piping installation.
 - 5. Coordinate installation with other trades. Route piping as required to avoid building structure, equipment, plumbing piping, HVAC piping, ductwork, lighting fixtures, electrical conduits and bus ducts and similar work. Final location of lighting will have priority over final sprinkler locations. Provide drains to trapped sections of system which result from such routing. Other trades take precedence for installation space.

6. Support piping adjacent to walls, overhead construction, columns and other structural and permanent enclosure elements of the building. Limit clearance to 2-inches wherever furring is indicated for concealment of piping. Allow for insulation thickness. Locate insulated piping to provide minimum 1-inch clearance outside insulation.
7. Wherever possible in finished and occupied spaces, conceal piping from view by locating within column or beam enclosures, hollow wall construction, or above suspended ceilings. Do not encase horizontal routes in solid partitions, except where approved.
8. General Electrical Equipment Clearances: Do not route piping through electrical rooms, transformer vaults, elevator equipment rooms and other electrical or electronic equipment spaces and enclosures. Do not route piping above electric power or lighting panel, switchgear, low voltage panel, or similar electric device.
9. Rooms Protected by Alternative Systems: Route water filled and dry system piping around rooms protected by pre-action systems, clean agent systems, gaseous suppression systems and other alternative fire suppression systems.
10. Install pipe runs to minimize obstruction to other work.
11. Pitch all dry and pre-action system piping 1/4-inch per 10-feet for mains and 1/2-inch per 10-feet for branch lines, including pipe passing through both warm and cold areas.

B. Couplings:

1. Install where indicated on Drawings and on each side of pieces of equipment to permit easy removal of equipment.
2. Deburr cut edges.

C. Pipe Penetrations: Wire pipe cutout coupon at point of pipe penetration.

D. Pipe and Pipe Fittings:

1. Expansion and Flexibility: Install work with due regard for expansion and contraction to prevent damage to the piping, equipment, building and its contents. Provide piping offsets, loops, approved type expansion joints, sway bracing, wire restraints, vertical restraints, flexible couplings or other means to control pipe movement and to minimize pipe forces.
2. Coordinate support of pipe 4-inches and larger with Structural Engineer.
3. Provide clearances around piping per NFPA 13.
4. Install dry and pre-action welded pipe with welds facing vertically up, or where this is not possible, as close as possible to vertical between 46 degrees and 234 degrees. Intent is to minimize corrosion caused by moisture in the bottom of pipes.

3.5 WALL AND FLOOR PENETRATIONS AND SLEEVES

A. Escutcheons: Install on exposed pipes passing through walls or floors.

1. Pipe Sleeves: Lay out work in advance of pouring concrete and furnish and set sleeves necessary to complete work.
2. Floor Sleeves: Provide sleeves on pipes passing through concrete or masonry construction. Extend sleeve 1-inch above finished floor. Caulk pipes passing through floor with nonshrinking fire and water resistant grout or approved equivalent caulking compound. Caulk/seal piping passing through fire rated building assembly with UL rated assemblies. Provide fire-rated assemblies per local AHJ requirements.
3. Wall Sleeves: Provide sleeves on pipes passing through concrete or masonry construction. Provide sleeve flush with finished face of wall. Caulk pipes passing through walls with non-shrinking caulking compound. Caulk/seal piping passing through

fire-rated building assemblies with UL Listed or FM Approved fire-rated firestopping compound. Provide fire-rated assemblies per local AHJ requirements.

4. Beam Sleeves: Coordinate with trades for locations of pipe sleeves in reinforced concrete and steel beams. Penetrations must be indicated on structural shop drawings. See Drawings and Specifications for specific sleeve location limitations. Pipe sleeve locations must be indicated on reinforced concrete and steel beam shop drawings. Field cutting of beams not allowed without written approval of structural engineer. No extra costs allowed for failure to coordinate beam penetrations prior to reinforced concrete and steel beam shop drawing submittal.
5. Penetrations in Fire-Rated Wall/Floor Assemblies:
 - a. Reference Division 07, Thermal and Moisture Protection.
 - b. Coordinate with Drawings location of fire rated walls, ceilings and floors. When these assemblies are penetrated, seal around piping and equipment with approved firestopping material.
 - c. Provide proper sizing when providing sleeves or core-drilled holes to accommodate the penetration. Firestop voids between sleeve or core-drilled hole and pipe passing through to meet the requirements of ASTM E814 and NFPA.
 - d. Install firestopping material complete as directed by manufacturer's installation instructions. Meet requirements of ASTM E814.

3.6 SWITCHES, VALVE SUPERVISORY

- A. Coordinate with Division 28, Electronic Safety.

3.7 SWITCHES, WATER DETECTOR

- A. Wire pipe cutout coupon at point of connection of switch to pipe.
- B. Flow switches: Connect to system side of valves and drain connections.
- C. Coordinate with Division 28, Electronic Safety.

3.8 HANGERS AND SUPPORTS

- A. Installation of pipe hangers, inserts and supports to conform to NFPA 13. Provide adjustable hangers, inserts, brackets, clamps, supplementary steel and other accessory materials required for proper support of pipe lines and equipment. Provide supplementary materials for proper support and attachment of hangers.

3.9 STRUTS AND STRUT CLAMPS

- A. Install per manufacturer's listed orientation.

3.10 ANCHORS AND ATTACHMENTS

- A. In post-tension construction, determine location of post-tension cables and install anchors to avoid contact or interference with post-tension cables. Coordinate with Structural.
- B. Do not use powder-driven attachments.

- C. Building Attachments and Inserts: Install building attachments within concrete slabs or attach to structural steel. Install additional attachments at concentrated loads, including valves and flanges, for sizes NPS 2-1/2 and larger. Install concrete inserts before concrete is placed; fasten inserts to forms and install reinforcing bars through openings at top of inserts.
- D. Hanger and Support Attachments:
 - 1. Concrete:
 - a. Before Pouring: Prior to installation, coordinate locations of cast in place concrete inserts with other trades. Install in accordance with manufacturer's instructions.
 - b. After Pouring:
 - 1) Where supports in slabs are required after concrete has been poured, provide drilled-in threaded inserts (mechanical-expansion anchors), installed in accordance with manufacturer's recommendations.
 - 2) Install mechanical-expansion anchors after concrete is completely cured and in accordance with manufacturer's installation instructions.
 - 3) Where anchors are to be installed in post-tension construction, determine and avoid locations of post-tension cables prior to drilling.
 - 2. Metal Floor Deck: Support hangers per UL Listing or FM Approval for selected concrete insert before pouring of concrete topping, or from beam clamps fastened to structural steel.
 - 3. Steel Joists: Support hangers from beam clamps fastened to bar joists or to auxiliary steel between bar joists as required.
 - 4. C-Clamp Hangers: Do not attach to one side of double-angle bottom members.
 - 5. Locate and install hangers, supports and attachments connecting to I-joists, structural insulated panels (SIPs), cross laminated timber and similar engineered structural products according to the structural product manufacturer specifications.
- E. Make available to the Architect information required to verify the anchorage, sway bracing and restraint of fire protection systems.

3.11 PIPE STANDS

- A. Secure to floor.
- B. Install to maintain pipe level and plumb.
- C. Securely attach to supported pipe by u-bolt.

3.12 GAUGES

- A. Install gauges conveniently and accessibly located with reference to finished building for repairs, removal and service.
- B. Install with dial positioned for maximum visibility.

3.13 BELLS

- A. Locate exterior alarm bells at 8-feet above finished grade. Coordinate with Architect.
- B. Coordinate with Divisions 26, Electrical and Division 28, Electronic Safety.

3.14 FIRE DEPARTMENT CONNECTION

- A. Locate with sufficient clearance from walls, obstructions, or adjacent siamese connectors to allow full swing of fire department wrench handle.
- B. Provide method of draining FDC piping. Drain to sanitary sewer by indirect connection, or to exterior where damage, including damage to landscaping and staining of concrete, will not occur.
- C. Locate away from building egress paths. Coordinate location with Fire Marshal.

3.15 VALVES

- A. General:
 - 1. Provide post indicator on buried control valves.
 - 2. Inspect valves for leaks. Adjust or replace packing to stop leaks. Replace valve if leak persists.
- B. Installation:
 - 1. Install valves where required for proper operation, testing and drainage. Locate valves so as to be accessible and so that separate support can be provided when necessary. Install conveniently and accessibly located with reference to finished building for repairs, removal and service.
 - 2. Swing Check Valves: Install in horizontal position with hinge pin horizontally perpendicular to centerline of pipe. Install for proper direction of flow.
- C. Pressure Relief Valves: Provide piping to permanent drain.

3.16 BACKFLOW PREVENTION DEVICES

- A. Install conveniently and accessibly located with reference to finished building for repairs, removal and service.
- B. Provide listed backflow assembly at sprinkler system water source connection. Coordinate with local utility; conform to their installation requirements.
- C. Provide method of forward flow testing at full system demand without dismantling any part of the system. Indicate location, method of testing and location of test drain discharge on submittal and As-Built Drawings. Provide signage as required by NFPA 13. Locate drainage for forward testing where damage will not occur, including damage to landscaping.
- D. Chain and padlock in "open" position. Provide two sets of keys.
- E. Provide control valve supervisory switches connected to the fire alarm system.

3.17 PIPE, VALVE, AND FIRE PROTECTION EQUIPMENT IDENTIFICATION

- A. Install engraved plastic laminate or corrosion resistant metal sign or plastic equipment marker, secured with corrosion-resistant chain or permanent adhesive on or near each Item of fire

suppression equipment and each operational device, as specified in this specification if not otherwise specified for each Item or device.

- B. Provide signs for the following general categories of equipment and operational devices: Valves, drains, pumps, standpipes, tanks and similar equipment.
- C. Each new piece of equipment to bear a permanently attached identification plate, listing manufacturer's name, capacities, sizes and characteristics.
- D. Piping to bear the manufacturer's name, schedule of thickness, size and ASTM identification number
- E. Provide valve tag on every valve, control device, main drain, auxiliary drain, and drum drip in each system. Exclude check valves and valves within factory fabricated equipment units. List each tagged valve in valve schedule for each piping system.
- F. List each tagged item and its location in valve schedule; identify on fire suppression drawings.
- G. Install framed, glass or rigid transparent plastic covered, mounted valve schedule and valve location drawing in main riser or fire pump room.
- H. Provide identification sign on ceiling tile below valve location.
- I. Provide permanent identification sign at pressure regulating valves stating required setting of pressure regulator.
- J. Adjusting: Relocate fire suppression identification device which has become visually blocked.
- K. Cleaning: Clean face of identification devices and glass frames of valve charts.

3.18 SIGNS

- A. General Information Signs: Provide a general information sign used to determine system design basis and information relevant to the inspection, testing and maintenance requirements required by NFPA 25, Standard for the Inspection, Testing and Maintenance of Water-Based Fire Protection Systems. Such general information is to be provided with a permanently marked weatherproof metal or rigid plastic sign, secured with corrosion-resistant wire, chain, or other acceptable means. Such signs are to be placed at each system control rise loop and auxiliary system control valve. The sign is to include the following information:
 - 1. Name and Location of the Facility Protected
 - 2. Presence of High-Piled and/or Rack Storage
 - 3. Maximum Height of Storage Planned
 - 4. Flow Test Data
 - 5. Location of Auxiliary Drains and Low Point Drains
 - 6. Original Results of Main Drain Flow Test
 - 7. Name of Installing Contractor or Designer
 - 8. Indication of presence and location of other auxiliary systems.

3.19 DRAINS

- A. Locate drain connections within 7-feet of floor. Provide piping capable of being fully drained.

- B. Provide a drain vent at top of vertical drains. Coordinate with Division 22, Plumbing.
- C. Coordinate location of auxiliary drains with Architect. Architect to approve location before drain is installed.
- D. Protect drains from tampering and accidental operation.
- E. Protect drain discharge at the exterior with a turned-down 45 degree elbow.

END OF SECTION

SECTION 21 1300 - FIRE SUPPRESSION SPRINKLER SYSTEMS

PART 1 - GENERAL

1.1 SUMMARY

- A. Work Included:
 - 1. Sprinklers
 - 2. Riser Manifold
 - 3. Inspector's Test Connection
 - 4. Wet System Air Vent
 - 5. Spare Sprinkler Cabinet
 - 6. Sprinkler Guards
- B. This is a contractor designed system. Contact AHJ prior to bid to verify fire system requirements. Provide design compliant with codes as interpreted by AHJ.
- C. Scope:
 - 1. Wet-Pipe Sprinkler System.
 - 2. Private fire service main running from 5-feet outside the building to the inlet connection inside the building. Provide required valves and appurtenances.
- D. Coordinate location and type of tamper, flow and pressure switches and fire alarm system.
- E. Provide electrical connections and wiring as required for a complete and operable system. Includes but is not limited to bells, air compressors, and sump pumps.

1.2 RELATED SECTIONS

- A. Contents of Division 21, Fire Suppression and Division 01, General Requirements apply to this Section.
- B. In addition, reference the following:
 - 1. Division 22, Plumbing
 - 2. Division 23, Heating, Ventilating and Air-Conditioning
 - 3. Division 26, Electrical
 - 4. Division 28, Electronic Safety
 - 5. Section 21 00 00, Fire Suppression Basic Requirements
 - 6. Section 21 05 00, Common Work Results for Fire Suppression

1.3 REFERENCES AND STANDARDS

- A. References and Standards as required by Section 21 00 00, Fire Suppression Basic Requirements and Division 01, General Requirements.

1.4 SUBMITTALS

- A. Submittals as required by Section 21 00 00, Fire Suppression Basic Requirements and Division 01, General Requirements.

- B. In addition, provide:
 - 1. Hydraulic calculations.
 - 2. Trapeze hanger details and calculations, including size, length and material. Additionally, provide size, weight and number of pipes to be carried on the trapeze.
 - 3. On submittal and As-Built drawings, provide text of sprinkler list to be installed in the spare sprinkler cabinet.

1.5 QUALITY ASSURANCE

- A. Quality assurance as required by Section 21 00 00, Fire Suppression Basic Requirements and Division 01, General Requirements.

1.6 WARRANTY

- A. Warranty of materials and workmanship as required by Section 21 00 00, Fire Suppression Basic Requirements and Division 01, General Requirements.

1.7 SYSTEM DESCRIPTION

- A. Provide coverage for entire building. Field verify field conditions prior to submittal of bid. Adjust bid to provide protection features in accordance with applicable codes and interpretations by AHJ. Provide design and installation based on more stringent requirements if this specification and AHJ requirements differ from Code.
- B. Design Parameters:
 - 1. Building Areas: Residential Areas and Adjoining Spaces.
 - a. Occupancy Classification: See requirements of NFPA 13R.
 - 2. Design parameters above are NFPA 13 minimums. Provide increased design densities, design areas and hose allowances to meet requirements of AHJ.
- C. Sprinkler system design to include a 10 percent pressure and flow cushion between system demand point and available water supplies.
- D. Extend hydraulic calculations from hydraulically most remote design area back to location of pressure hydrant or flow test or effective point of water supply where characteristics of water supply are known.

1.8 EXTRA STOCK

- A. Provide extra sprinklers per code.
- B. Provide suitable wrenches for each sprinkler type and metal storage cabinet in riser room.

1.9 CONTROL VALVES

- A. Sprinkler system control valves to be OS&Y or butterfly valves located inside building in a room with outside door.

PART 2 - PRODUCTS

2.1 MANUFACTURERS

A. Sprinklers:

1. Finished Areas:
 - a. Victaulic
 - b. Viking
 - c. Tyco
 - d. Reliable
 - e. Globe
 - f. Senju
 - g. Or approved equivalent.
2. Nonfinished Areas:
 - a. Victaulic
 - b. Viking
 - c. Tyco
 - d. Reliable
 - e. Globe
 - f. Or approved equivalent.
3. Dry Sprinklers:
 - a. Victaulic
 - b. Viking
 - c. Tyco
 - d. Reliable
 - e. Or approved equivalent.

B. Riser Manifold:

1. Viking EasyPac
2. Reliable; Model CR.
3. AGF; Model 8011.
4. Tyco; Model RM-1
5. Or approved equivalent.

C. Inspector's Test Connection:

1. Combination Test and Drain:
 - a. Victaulic; Series 720 TestMaster II Alarm Test Module with pressure relief valve.
 - b. AGF; Model 1011, 2511, 3011, with pressure relief valve.
 - c. Or approved equivalent.

D. Wet System Air Vent:

1. Potter Electric Signal Company; Model PAV
2. Or approved equivalent.

E. Spare Sprinkler Cabinet:

1. Victaulic
2. Fire Protection Products, Inc. (FPPI).
3. Tyco Fire & Building Products

4. Allied Rubber and Gasket Co.
5. Potter Roemer Fire Pro.
6. Or approved equivalent.

F. Sprinkler Guards:

1. Victaulic
2. Viking
3. Tyco
4. Reliable
5. Globe
6. Senju
7. Or approved equivalent.

2.2 SPRINKLERS

A. Finished Areas:

1. Type: Glass-Bulb
2. Style: Recessed
3. Response:
 - a. Quick-Response
4. Finish: Architect to select from standard available finishes.
5. Escutcheon: Architect to select from standard available finishes.

B. Nonfinished Areas:

1. Type: Glass-Bulb
2. Response: Quick-Response
3. Finish: Brass

C. Residential Sprinklers:

1. Type: Glass-Bulb
2. Style: Concealed
3. Response: Residential
4. Finish: Architect to select from standard available finishes.
5. Coverplate for Concealed Sprinklers: Flat Plate

D. Dry Sprinklers:

1. Type: Glass-Bulb
2. Style: Recessed
3. Response: Quick-Response
4. Finish: Architect to select from standard available finishes.
5. Escutcheon: Architect to select from standard available finishes.
6. Dry Sprinkler Boot: Manufactured for use with the dry sprinkler it protects.

2.3 RISER MANIFOLD

- A. Water-flow alarm, gauge, integral pressure relief valve connected to drain, pressure gauge with 3-way gauge control valve and drain valve, integral pressure relief valve connected to drain, sight glass, smooth bore orifice union of same size as smallest orifice sprinkler installed. Provide cover tamper switch when required by AHJ.

2.4 INSPECTOR'S TEST CONNECTION

- A. Combination Test and Drain: Bronze body, brass stem, impregnated Teflon seat, chrome coated brass ball, steel handle with positive stops, tamper resistant test orifice, integral tamper resistant sight glasses, tapped and plugged port for system access, steel identification plate. Provide with pressure relief valve and drainage piping with bronze body and stainless steel spring.

2.5 WET SYSTEM AIR VENT

- A. Brass, UL 2573 with ball valve supervisory switch.

2.6 SPARE SPRINKLER CABINET

- A. NFPA 13 Systems: Sized to accommodate a minimum of two spare sprinklers of each Sprinkler Identification Number (SIN), manufacturer, model, orifice, deflector type, temperature and thermal sensitivity, or a minimum of six sprinklers for facilities having under 300 sprinklers, or a minimum of 12 sprinklers for facilities having 300 to 1000 sprinklers, or a minimum of 24 sprinklers for facilities having over 1000 sprinklers, whichever is more.
- B. Welded steel with hinged steel cover.
- C. Red enamel or polyester coated finish inside and out.

2.7 SPRINKLER GUARDS

- A. Metal.
- B. Listed for use with sprinkler model to which it is attached.

PART 3 - EXECUTION

3.1 GENERAL INSTALLATION REQUIREMENTS

- A. Install per manufacturer's requirements and recommendations.

3.2 SPRINKLERS

- A. Center sprinklers in center or quarter points of suspended ceiling tile.
- B. Align sprinklers with architectural column lines, lighting, diffusers and other ceiling features. In unfinished ceilings, route piping to minimize visual impact. Sprinklers and piping not so aligned are to be removed and replaced at no additional cost to Owner.
- C. Install dry sprinklers in a manner which does not trap water.

3.3 RISER MANIFOLD

- A. Install so valves and gauges are conveniently and accessibly located with reference to finished building for repairs, removal and service.

- B. Provide connection to drain.
- C. Pipe pressure relief valve to drain.
- D. Install with supervised control valve(s) and check valve.

3.4 INSPECTOR'S TEST CONNECTION

- A. Locate where full flow discharge or pressure relief valve discharge will not do damage, including damage to landscaping and will not cause dangerous conditions to walking surfaces or discoloration to building surfaces.
- B. Locate within 5-feet of finished floor.

3.5 WET SYSTEM AIR VENT

- A. Locate at a point in the system that will vent the most air.
- B. Connect at top of pipe.
- C. Locate so as not to interfere with sprinkler spray pattern.
- D. Locate where it can be easily accessed for inspection and cleaning.
- E. Pipe output of air vent to drain with an indirect connector or to exterior where it will not cause damage.

3.6 SPARE SPRINKLER CABINET

- A. Attach to wall at the main sprinkler system riser.
- B. Locate so cover is easy to open and readily accessible.
- C. Locate in an area with a temperature between 40 and 100 degrees Fahrenheit (4 and 38 degrees Celsius).
- D. Locate sprinkler wrenches inside cabinet.
- E. Inside the cabinet, provide a list of sprinklers installed in the property, including sprinkler identification number, manufacturer, model, orifice, deflector type, thermal sensitivity and pressure rating, quantity of each type to be contained in the cabinet and issue or revision date of the list.

3.7 SPRINKLER GUARDS

- A. Install per manufacturer's instructions and recommendations.

END OF SECTION

SECTION 22 0000 - PLUMBING BASIC REQUIREMENTS

PART 1 - GENERAL

1.1 SECTION INCLUDES

- A. Work included in 22 00 00, Plumbing Basic Requirements applies to Division 22, Plumbing work to provide materials, labor, tools, permits, incidentals, and other services to provide and make ready for Owner's use of plumbing systems for proposed project.
- B. Contract Documents include, but are not limited to, Specifications including Division 00, Procurement and Contracting Requirements and Division 01, General Requirements, Drawings, Addenda, Owner/Architect Agreement, and Owner/Contractor Agreement. Confirm requirements before commencement of work.
- C. Definitions:
 - 1. Provide: To furnish and install, complete and ready for intended use.
 - 2. Furnish: Supply and deliver to project site, ready for unpacking, assembly and installation.
 - 3. Install: Includes unloading, unpacking, assembling, erecting, installation, applying, finishing, protecting, cleaning and similar operations at project site as required to complete items of work furnished.
 - 4. Approved or Approved Equivalent: To possess the same performance qualities and characteristics and fulfill the utilitarian function without any decrease in quality, durability or longevity. For equipment/products defined by the Contractor as "equivalent", substitution requests must be submitted to Engineer for consideration, in accordance with Division 01, General Requirements, and approved by the Engineer prior to submitting bids for substituted items.
 - 5. Authority Having Jurisdiction (AHJ): Indicates reviewing authorities, including local fire marshal, Owner's insurance underwriter, Owner's Authorized Representative, and other reviewing entity whose approval is required to obtain systems acceptance.

1.2 RELATED SECTIONS

- A. Contents of Section applies to Division 22, Plumbing Contract Documents.
- B. Related Work:
 - 1. Additional conditions apply to this Division including, but not limited to:
 - a. Specifications including Division 00, Procurement and Contracting Requirements and Division 01, General Requirements.
 - b. Drawings
 - c. Addenda
 - d. Owner/Architect Agreement
 - e. Owner/Contractor Agreement
 - f. Codes, Standards, Public Ordinances and Permits

1.3 REFERENCES AND STANDARDS

- A. References and Standards per Division 00, Procurement and Contracting Requirements, Division 01, General Requirements, individual Division 22, Plumbing Sections and those listed in this Section.
- B. Codes to include latest adopted editions, including current amendments, supplements and local jurisdiction requirements in effect as of the date of the Contract Documents, of/from:
1. State of Virginia:
 - a. 2012 International Building Code (IBC) with corresponding Virginia Construction Code Supplement
 - b. 2012 International Mechanical Code (IMC) with corresponding Virginia Construction Code Supplement
 - c. 2012 International Plumbing Code (IPC) with corresponding Virginia Construction Code Supplement
 - d. 2012 International Fuel Gas Code (IFGC) with corresponding Virginia Construction Code Supplement
 - e. 2012 National Electric Code (NFPA 70-2011) with corresponding Virginia Construction Code Supplement
 - f. 2012 International Energy Conservation Code (IECC) with corresponding Virginia Construction Code Supplement
- C. Reference standards and guidelines include but are not limited to the latest adopted editions from:
1. ABA - Architectural Barriers Act
 2. ADA - Americans with Disabilities Act
 3. AHRI - Air-Conditioning Heating & Refrigeration Institute
 4. ANSI - American National Standards Institute
 5. ASCE - American Society of Civil Engineers
 6. ASHRAE - American Society of Heating, Refrigerating and Air-Conditioning Engineers
 7. ASHRAE Guideline 0, the Commissioning Process
 8. ASME - American Society of Mechanical Engineers
 9. ASPE - American Society of Plumbing Engineers
 10. ASSE - American Society of Sanitary Engineering
 11. ASTM - ASTM International
 12. AWWA - American Water Works Association
 13. CFR - Code of Federal Regulations
 14. CGA - Compressed Gas Association
 15. CISPI - Cast Iron Soil Pipe Institute
 16. ETL - Electrical Testing Laboratories
 17. EPA - Environmental Protection Agency
 18. FM - FM Global
 19. IAPMO - International Association of Plumbing and Mechanical Officials
 20. GAMA - Gas Appliance Manufacturers Association
 21. HI - Hydraulic Institute Standards
 22. ISO - International Organization for Standardization
 23. MSS - Manufacturers Standardization Society
 24. NEC - National Electric Code

25. NEMA - National Electrical Manufacturers Association
26. NFGC - National Fuel Gas Code
27. NFPA - National Fire Protection Association
28. NRCA - National Roofing Contractors Association
29. NSF - National Sanitation Foundation
30. OSHA - Occupational Safety and Health Administration
31. SMACNA - Sheet Metal and Air Conditioning Contractors' National Association, Inc.
32. TEMA - Tubular Exchanger Manufacturers Association
33. TIMA - Thermal Insulation Manufacturers Association
34. UL - Underwriters Laboratories Inc.

D. See Division 22, Plumbing individual Sections for additional references.

1.4 SUBMITTALS

- A. See Division 01, General Requirements for Submittal Procedures as well as specific individual Division 22, Plumbing Sections.
- B. Provide drawings in format and software release equal to the design documents. Drawings to be the same sheet size and scale as the Contract Documents.
- C. In addition:
 1. "No Exception Taken" constitutes that review is for general conformance with the design concept expressed in the Contract Documents for the limited purpose of checking for conformance with information given. Any action is subject to the requirements of the Contract Documents. Contractor is responsible for the dimensions and quantity and will confirm and correlate at the job site, fabrication processes and techniques of construction, coordination of the work with that of all other trades, and the satisfactory performance of the work.
 2. Provide product submittals and shop drawings in electronic format only. Electronic format must be submitted via zip file via e-mail. For electronic format, provide one file per division containing one bookmarked PDF file with each bookmark corresponding to each Specification Section. Arrange bookmarks in ascending order of Specification Section number. Individual submittals sent piecemeal in a per Specification Section method will be returned without review or comment. All transmissions/submissions to be submitted to Architect. At Contractor's option, two separate submittals may be provided, consisting of underground work and building work. Deviations will be returned without review.
 3. Product Data: Provide Manufacturer's descriptive literature for products specified in Division 22, Plumbing Sections.
 4. Identify/mark each submittal in detail. Note what differences, if any, exist between the submitted item and the specified item. Failure to identify the differences will be considered cause for disapproval. If differences are not identified and/or not discovered during the submittal review process, Contractor remains responsible for providing equipment and materials that meet the Specifications and Drawings.
 - a. Label submittal to match numbering/references as shown in Contract Documents and schedules. Highlight and label applicable information to individual equipment or cross out/remove extraneous data not applicable to submitted model. Clearly note options and accessories to be provided, including field installed items. Highlight connections by/to other trades.

- b. Include technical data, installation instructions and dimensioned drawings for products, fixtures, equipment and devices installed, furnished or provided. Reference Division 22, Plumbing Sections for specific items required in product data submittal outside of these requirements.
 - c. Provide pump curves, operation characteristics, capacities, ambient noise criteria, etc. for equipment.
 - d. For vibration isolation of equipment, list make and model selected with operating load and deflection. Indicate frame type where required. Submit manufacturer's product data.
 - e. See Division 22, Plumbing Sections for additional submittal requirements outside of these requirements.
5. Maximum of two reviews of complete submittal package. Arrange for additional reviews and/or early review of long-lead items; Bear costs of additional reviews at Engineer's hourly rates. Incomplete submittal packages/submittals will be returned to contractor without review.
6. Resubmission Requirements: Make corrections or changes in submittals as required, and in consideration of Engineer's comments. Identify Engineer's comments and provide an individual response to each of the Engineer's comments. Cloud changes in the submittals and further identify changes which are in response to Engineer's comments.
7. Trade Coordination: Include physical characteristics, electrical characteristics, device layout plans, wiring diagrams, and connections as required per Division 22, Plumbing Coordination Documents. For equipment with electrical connections, furnish copy of approved submittal for inclusion in Division 26, Electrical submittals.
8. Make provisions for openings in building for admittance of equipment prior to start of construction or ordering of equipment.
9. Substitutions and Variation from Basis of Design:
 - a. The Basis of Design designated product establishes the qualities and characteristics for the evaluation of any comparable products by other listed acceptable manufacturers if included in this Specification or included in an approved Substitution Request as judged by the Design Professional.
 - b. If substitutions and/or equivalent equipment/products are being proposed, it is the responsibility of parties concerned, involved in, and furnishing the substitute and/or equivalent equipment to verify and compare the characteristics and requirements of that furnished to that specified and/or shown. If greater capacity and/or more materials and/or more labor is required for the rough-in, circuitry or connections than for the item specified and provided for, then provide compensation for additional charges required for the proper rough-in, circuitry and connections for the equipment being furnished. No additional charges above the Base Bid, including resulting charges for work performed under other Divisions, will be allowed for such revisions. Coordinate with the requirements of "Submittals". For any product marked "or approved equivalent", a substitution request must be submitted to Engineer for approval prior to purchase, delivery or installation.
10. Shop Drawings: Provide coordinated Shop Drawings which include physical characteristics of all systems, equipment and piping layout plans, and control wiring diagrams. Reference individual Division 22, Plumbing Sections for additional requirements for Shop Drawings outside of these requirements.
 - a. Provide Shop Drawings indicating sanitary and storm cleanout locations and type to Architect for approval prior to installation.

- b. Provide Shop Drawings indicating access panel locations, size and elevation for approval prior to installation.
11. Samples: Provide samples when requested by individual Sections.
12. Resubmission Requirements:
 - a. Make any corrections or change in submittals when required. Provide submittals as specified. The engineer will not be required to edit and/or interpret the Contractor's submittals. Indicate changes for the resubmittal in a cover letter with reference to page(s) changed and reference response to comment. Cloud changes in the submittals.
 - 1) Resubmit for review until review indicates no exception taken or "make corrections as noted".
 - 2) When submitting drawings for Engineers re-review, clearly indicate changes on drawings and "cloud" any revisions. Submit a list describing each change.
13. Operation and Maintenance Manuals, Owner's Instructions:
 - a. Submit, at one time, electronic files (PDF format) of manufacturer's operation and maintenance instruction manuals and parts lists for equipment or items requiring servicing. Include valve charts. Submit data when work is substantially complete and in same order format as submittals. Include name and location of source parts and service for each piece of equipment.
 - 1) Include copy of approved submittal data along with submittal review letters received from Engineer. Data to clearly indicate installed equipment model numbers. Delete or cross out data pertaining to other equipment not specific to this project.
 - 2) Include copy of manufacturer's standard Operations and Maintenance for equipment. At front of each tab, provide routine maintenance documentation for scheduled equipment. Include manufacturer's recommended maintenance schedule and highlight maintenance required to maintain warranty. Furnish list of routine maintenance parts, including part numbers, sizes, quantities, relevant to each piece of equipment: belts, motors, lubricants, and filters.
 - 3) Include copy of complete parts list for equipment. Include available exploded views of assemblies and sub assemblies.
 - 4) Include copy of startup and test reports specific to each piece of equipment.
 - 5) Include copy of final water systems balancing log along with pump operating data.
 - 6) Include commissioning reports.
 - 7) Include copy of pressure, flow, leakage and purity test data and air and water systems test data, as applicable. Include copy of third-party and state and local jurisdiction inspection reports.
 - 8) Include copy of valve charts/schedules.
 - 9) Include Warranty per Division 00, Procurement and Contracting Requirements and Division 01, General Requirements, Section 22 00 00, Plumbing Basic Requirements and individual Division 22, Plumbing Sections.
 - 10) Include product certificates of warranties and guarantees.
 - 11) Engineer will return incomplete documentation without review. Engineer will provide one set of review comments in Submittal Review format. Contractor must arrange for additional reviews; Contractor to bear costs for additional reviews at Engineer's hourly rates.

- b. Thoroughly instruct Owner in proper operation of equipment and systems. Where noted in individual Sections, training will include classroom instruction with applicable training aids and systems demonstrations. Field instruction per Section 22 00 00, Plumbing Basic Requirements article titled "Demonstration".
 - c. Copies of certificates of code authority inspections, acceptance, code required acceptance tests, letter of conformance and other special guarantees, certificates of warranties, specified elsewhere or indicated on Drawings.
14. Record Drawings:
- a. Maintain at site at least one set of drawings for recording "As-constructed" conditions. Indicate on Drawings changes to original documents by referencing revision document, and include buried elements, location of cleanouts, and location of concealed mechanical items. Include items changed by field orders, supplemental instructions, and constructed conditions.
 - b. Record Drawings are to include equipment and fixture/connection schedules that accurately reflect "as constructed or installed" for project.
 - c. At completion of project, input changes to original project on Revit Model and make one set of black-line drawings created from Revit Model in version/release equal to contract drawings. Submit Revit disk and drawings upon substantial completion.
 - d. Provide Invert elevations and dimensioned locations for water services, building waste, and storm drainage piping below grade extending to 5-feet outside building line.
 - e. See Division 22, Plumbing individual Sections for additional items to include in record drawings.

1.5 QUALITY ASSURANCE

- A. Regulatory Requirements: Work and materials installed to conform with all local, State and Federal codes, and other applicable laws and regulations. Where code requirements are at variance with Contract Documents, meet code requirements as a minimum requirement and include costs necessary to meet these in Contract. Machinery and equipment are to comply with OSHA requirements, as currently revised and interpreted for equipment manufacturer requirements. Install equipment provided per manufacturer recommendations.
- B. Whenever this Specification calls for material, workmanship, arrangement or construction of higher quality and/or capacity than that required by governing codes, higher quality and/or capacity take precedence.
- C. Drawings are intended to be diagrammatic and reflect the Basis of Design manufacturers equipment. They are not intended to show every item in its exact dimensions, or details of equipment or proposed systems layout. Verify actual dimensions of systems (i.e., piping) and equipment proposed to assure that systems and equipment will fit in available space. Contractor is responsible for design and construction costs incurred for equipment other than Basis of Design, including, but not limited to, architectural, structural, electrical, HVAC, fire sprinkler, and plumbing systems.
- D. Manufacturer's Instructions: Follow manufacturer's written instructions. If in conflict with Contract Documents, obtain clarification. Notify Engineer/Architect, in writing, before starting work.

- E. Items shown on Drawings are not necessarily included in Specifications or vice versa. Confirm requirements in all Contract Documents.
- F. Provide products that are UL listed.
- G. Piping Insulation products to contain less than 0.1 percent by weight PBDE in all insulating materials.
- H. All potable water system components, devices, material, or equipment containing a weighted average of greater than 0.25 percent lead are prohibited, and shall be certified in accordance with current editions of the Safe Drinking Water Act (SDWA), NSF 61 & NSF 372. Endpoint devices used to dispense water for drinking shall meet the requirements of NSF 61.
- I. ASME Compliance: ASME listed water heaters and boilers with an input of 200,000 BTUH and higher, hot water storage tanks which exceed 120 gallons, and hot water expansion tanks which are connected to ASME rated equipment or required by code or local jurisdiction.
- J. Provide safety controls required by National Boiler Code (ASME CSD 1) for boilers and water heaters with an input of 400,000 BTUH and higher.

1.6 WARRANTY

- A. Provide written warranty covering the work for a period of one year from date of Substantial Completion in accordance with Division 00, Contracting and Procurement Requirements, Division 01, General Requirements, Section 22 00 00, Plumbing Basic Requirements and individual Division 22, Plumbing Sections.
- B. Sections under this Division can require additional and/or extended warranties that apply beyond basic warranty in Division 01, General Requirements and the General Conditions. Confirm requirements in all Contract Documents.

1.7 COORDINATION DOCUMENTS

- A. Prior to construction, coordinate installation and location of HVAC equipment, ductwork, grilles, diffusers, piping, plumbing equipment/fixtures, fire sprinklers, plumbing, cable trays, lights, and electrical services with architectural and structural requirements, and other trades (including ceiling suspension, and tile systems), and provide maintenance access requirements. Coordinate with submitted architectural systems (i.e. roofing, ceiling, finishes) and structural systems as submitted, including footings and foundation. Identify zone of influence from footings and ensure systems are not routed within the zone of influence.
- B. Advise Architect in the event a conflict occurs in location or connection of equipment. Bear costs resulting from failure to properly coordinate installation or failure to advise Architect of conflict.
- C. Verify in field exact size, location, invert, and clearances regarding existing material, equipment and apparatus, and advise Architect of discrepancies between that indicated on Drawings and that existing in field prior to installation related thereto.
- D. Submit final Coordination Drawings with changes as Record Drawings at completion of project.

1.8 VIRIDIANT REQUIREMENTS

- A. Project seeks Net-Zero ready, as outlined by Viridiant's Residential Net-Zero program.
- B. Obtain list of credits sought by project. Be familiar with requirements for credits. See Division 00, Procurement and Contracting Requirements and Division 01, General Requirements for requirements.
- C. Provide materials and services as outlined in appropriate Viridiant Residential Net-Zero Reference Guide.
- D. Provide documentation as outlined in appropriate Viridiant Residential Net-Zero Reference Guide.
- E. Coordinate start-up, testing, training, and installation with Commissioning Agent as required to meet commissioning requirements.
- F. Provide adequate schedule for construction activities such as building flush out.

1.9 WORK INCLUDED

- A. Furnish and install sleeves, inserts and anchorage required for the installation, which are embedded in work of other trades. Sleeve, wrap and seal piping in concrete.
- B. Electrical: For plumbing trim/devices/equipment, provide, from the line voltage connection by Division 26, the low voltage electrical connections and wiring as required for complete and operable system. Includes, but is not limited to: Low voltage electrical raceway, wiring and accessories, such as step-down transformers as necessary for function of sensors and automatic valve and faucet controls. Supply step-down transformers and size wiring as recommended by manufacturer of plumbing trim/faucets requiring electrical low voltage connection.

PART 2 - PRODUCTS

2.1 MANUFACTURERS

- A. Articles, fixtures, and equipment of a kind to be standard product of one manufacturer, including but not limited to fixtures, pumps, drains and equipment.

2.2 STANDARDS OF MATERIALS AND WORKMANSHIP

- A. Base contract upon furnishing materials as specified. Materials, equipment, and fixtures used for construction are to be new, latest products as listed in manufacturer's printed catalog data and are to be UL approved or have adequate approval or be acceptable by State, County, and City authorities.
- B. Names and manufacturer's names denote character and quality of equipment desired and are not to be construed as limiting competition.
- C. Hazardous Materials:

1. Comply with local, State of Virginia, and Federal regulations relating to hazardous materials.
2. Comply with Division 00, Procurement and Contracting Requirements and Division 01, General Requirements for this project relating to hazardous materials.
3. Do not use any materials containing a hazardous substance. If hazardous materials are encountered, do not disturb; immediately notify Owner and Architect. Hazardous materials will be removed by Owner under separate contract.

PART 3 - EXECUTION

3.1 ACCESSIBILITY AND INSTALLATION

- A. Confirm Accessibility and Installation requirements in Division 00, Procurement and Contracting Requirements, Division 01, General Requirements, Section 22 00 00, Plumbing Basic Requirements and individual Division 22, Plumbing Sections.
- B. Install equipment requiring access (i.e., drain pans, drains, control operators, valves, motors, cleanouts and water heaters) so that they may be serviced, reset, replaced or recalibrated by service people with normal service tools and equipment. Do not install equipment in obvious passageways, doorways, scuttles or crawlspaces which would impede or block intended usage.
- C. Install equipment and products complete as directed by manufacturer's installation instructions. Obtain installation instructions from manufacturer prior to rough-in of equipment and examine instructions thoroughly. When requirements of installation instructions conflict with Contract Documents, request clarification from Architect prior to proceeding with installation. This includes proper installation methods, sequencing, and coordination with other trades and disciplines.
- D. Earthwork:
 1. Confirm Earthwork requirements in Contract Documents. In absence of specific requirements, comply with individual Division 22, Plumbing Sections and the following:
 - a. Perform excavation, dewatering, shoring, bedding, and backfill required for installation of work in this Division in accordance with the provisions of related earthwork Sections/divisions. Contact utilities and locate existing utilities prior to excavation. Repair any work damaged during excavation or backfilling.
 - b. Excavation: Do not excavate under footings, foundation bases, or retaining walls.
 - c. Provide protection of underground systems. Review the project Geotechnical Report for references to corrosive or deleterious soils which will reduce the performance or service life of underground systems materials.
- E. Firestopping:
 1. Confirm Firestopping requirements in Division 07, Thermal and Moisture Protection. In absence of specific requirements, comply with individual Division 22, Plumbing Sections and the following:
 - a. Coordinate location and protection level of fire and/or smoke rated walls, ceilings, and floors. When these assemblies are penetrated, seal around piping, ductwork and equipment with approved firestopping material. Install firestopping material complete as directed by manufacturer's installation instructions. Meet requirements of ASTM E814, Standard Test Method for Fire Tests of Through-Penetration Fire Stops.

- F. Pipe Installation:
1. Provide installation of piping systems coordinated to account for expansion and contraction of piping materials and building as well as anticipated settlement or shrinkage of building. Install work to prevent damage to piping, equipment, and building and its contents. Provide piping offsets, loops, expansion joints, sleeves, anchors or other means to control pipe movement and minimize forces on piping. Verify anticipated settlement and/or shrinkage of building with Project Structural Engineer. Verify construction phasing, type of building construction products and rating for coordinating installation of piping systems.
 2. Include provisions for servicing and removal of equipment without dismantling piping.
- G. Plenums:
1. Provide plenum rated materials that meet the requirements to be installed in plenums. Immediately notify Architect/Engineer of discrepancy.

3.2 REVIEW AND OBSERVATION

- A. Confirm Review and Observation requirements in Division 00, Procurement and Contracting Requirements, Division 01, General Requirements, Section 22 00 00, Plumbing Basic Requirements and individual Division 22, Plumbing Sections.
- B. Notify Architect, in writing, at following stages of construction so that they may, at their option, visit site for review and construction observation:
1. Underground piping installation prior to backfilling.
 2. Prior to covering walls.
 3. Prior to ceiling cover/installation.
 4. When main systems, or portions of, are being tested and ready for inspection by AHJ.
- C. Bear responsibility and cost to make piping accessible, to expose concealed lines, or to demonstrate acceptability of the system. If Contractor fails to notify Architect at times prescribed above, costs incurred by removal of such work are the responsibility of the Contractor.
- D. Final Punch:
1. Prior to requesting a final punch visit from the Engineer, request from Engineer the Plumbing Precloseout Checklist, complete the checklist confirming completion of systems' installation, and return to Engineer. Request a final punch visit from the Engineer, upon Engineer's acceptance that the plumbing systems are ready for final punch.
 2. Costs incurred by additional trips required due to incomplete systems will be the responsibility of the Contractor.

3.3 CONTINUITY OF SERVICE

- A. Confirm requirements in Division 00, Procurement and Contracting Requirements and Division 01, General Requirements. In absence of specific requirements, comply with individual Division 22, Plumbing Sections and the following:

1. During remodeling or addition to existing structures, while existing structure is occupied, current services to remain intact until new construction, facilities or equipment is installed.
2. Prior to changing over to new service, verify that every item is thoroughly prepared. Install new piping, and wiring to point of connection.
3. Coordinate transfer time to new service with Owner. If required, perform transfer during off peak hours. Once changeover is started, pursue to its completion to keep interference to a minimum.
 - a. If overtime is necessary, there will be no allowance made by Owner for extra expense for such overtime or shift work.
4. Organize work to minimize duration of power interruption.

3.4 CUTTING AND PATCHING

- A. Confirm Cutting and Patching requirements in Division 01, General Requirements. In absence of specific requirements, comply with individual Division 22, Plumbing Sections and the following:
 1. Proposed floor cutting/core drilling/sleeve locations to be approved by Project Structural Engineer. Submit proposed locations to Architect/Project Structural Engineer. Where slabs are of post tension construction, perform x-ray scan of proposed penetration locations and submit scan results including proposed penetration locations to Project Structural Engineer/Architect for approval. Where slabs are of waffle type construction, show column cap extent and cell locations relative to proposed penetration(s).
 2. Cutting, patching and repairing for work specified in this Division including plastering, masonry work, concrete work, carpentry work, and painting included under this Section will be performed by skilled craftsmen of each respective trade in conformance with appropriate Division of Work.
 3. Additional openings required in building construction to be made by drilling or cutting. Use of jack hammer is specifically prohibited. Patch openings in and through concrete and masonry with grout.
 4. Restore new or existing work that is cut and/or damaged to original condition. Patch and repair specifically where existing items have been removed. This includes repairing and painting walls, ceilings, etc. where existing piping and devices are removed as part of this project. Where alterations disturb lawns, paving, and walks, surfaces to be repaired, refinished and left in condition matching existing prior to commencement of work.
 5. Additional work required by lack of proper coordination will be provided at no additional cost to the Owner.

3.5 EQUIPMENT SELECTION AND SERVICEABILITY

- A. Replace or reposition equipment which is too large or located incorrectly to permit servicing, at no additional cost to Owner.

3.6 DELIVERY, STORAGE AND HANDLING

- A. Confirm requirements in Division 00, Procurement and Contracting Requirements and Division 01, General Requirements. In absence of specific requirements, comply with individual Division 22, Plumbing Sections and the following:
 1. Handle materials delivered to project site with care to avoid damage. Store materials on site inside building or protected from weather, dirt and construction dust. Insulation and

lining that becomes wet from improper storage and handling to be replaced before installation. Products and/or materials that become damaged due to water, dirt and/or dust as a result of improper storage to be replaced before installation.

2. Protect equipment and pipe to avoid damage. Close pipe openings with caps or plugs. Keep motors and bearings in watertight and dustproof covers during entire course of installation.
3. Protect bright finished shafts, bearing housings and similar items until in service.

3.7 DEMONSTRATION

- A. Confirm Demonstration requirements in Division 00, Procurement and Contracting Requirements, Division 01, General Requirements, Section 22 00 00, Plumbing Basic Requirements and individual Division 22, Plumbing Sections.
- B. Upon completion of work and adjustment of equipment and test systems, demonstrate to Owner's Authorized Representative, Architect and Engineer that equipment furnished and installed or connected under provisions of these Specifications functions in manner required. Provide field instruction to Owner's Maintenance Staff as specified in Division 01, General Requirements, Section 22 00 00, Plumbing Basic Requirements and individual Division 22, Plumbing Sections.
- C. Manufacturer's Field Services: Furnish services of a qualified person at time approved by Owner, to instruct maintenance personnel, correct defects or deficiencies, and demonstrate to satisfaction of Owner that entire system is operating in satisfactory manner and complies with requirements of other trades that may be required to complete work. Complete instruction and demonstration prior to final job site observations.
- D. Training and Demonstration per Section 01 91 13, General Commissioning Requirements and 22 08 00, Commissioning of Plumbing.

3.8 CLEANING

- A. Confirm cleaning requirements in Division 00, Procurement and Contracting Requirements, Division 01, General Requirements, Section 22 00 00, Plumbing Basic Requirements and individual Division 22, Plumbing Sections.
- B. Upon completion of installation, thoroughly clean exposed portions of equipment, removing temporary labels and traces of foreign substances. Throughout work, remove construction debris and surplus materials accumulated during work.

3.9 INSTALLATION

- A. Confirm installation requirements in Division 00, Procurement and Contracting Requirements, Division 01, General Requirements, Section 22 00 00, Plumbing Basic Requirements and individual Division 22, Plumbing Sections.
- B. Install equipment and fixtures in accordance with manufacturer's installation instructions, plumb and level and firmly anchored to vibration isolators. Maintain manufacturer's recommended clearances.

- C. Start up equipment, in accordance with manufacturer's start-up instructions, and in presence of manufacturer's representative. Test controls and demonstrate compliance with requirements. Replace damaged or malfunctioning controls and equipment.
 - 1. Do not place equipment in sustained operation prior to initial balancing of plumbing systems.
 - 2. Provide pump impellers to obtain Basis of Design design capacities.
- D. Provide miscellaneous supports/metals required for installation of equipment and piping.

3.10 PAINTING

- A. Confirm requirements in Division 01, General Requirements and Division 09, Finishes. In absence of specific requirements, comply with individual Division 22, Plumbing Sections and the following:
 - 1. Ferrous Metal: After completion of plumbing work, thoroughly clean and paint exposed supports constructed of ferrous metal surfaces, i.e., hangers, hanger rods, equipment stands, with one coat of black asphalt for exterior or black enamel for interior, suitable for hot surfaces.
 - 2. In a mechanical room, on roof or other exposed areas, machinery and equipment not painted with enamel to receive two coats of primer and one coat of rustproof enamel, colors as selected by Architect.
 - 3. See individual equipment Specifications for other painting.
 - 4. Structural Steel: Repair damage to structural steel finishes or finishes of other materials damaged by cutting, welding or patching to match original.
 - 5. Piping: Clean, primer coat and paint exposed piping on roof or at other exterior locations with two coats paint suitable for metallic surfaces and exterior exposures. Color selected by Architect.
 - 6. Covers: Covers such as manholes, cleanouts and the like will be furnished with finishes which resist corrosion and rust.

3.11 DEMOLITION

- A. Confirm Demolition requirements in Division 01, General Requirements and Division 02, Existing Conditions. In absence of specific requirements, comply with individual Sections in Division 22, Plumbing and the following:
 - 1. Scope:
 - a. It is the intent of these documents to provide necessary information and adjustments to plumbing system required to meet code, and accommodate installation of new work.
 - b. Coordinate with Owner so that work can be scheduled not to interrupt operations, normal activities, building access or access to different areas.
 - c. Existing Conditions: Determine exact location of existing utilities and equipment before commencing work, compensate Owner for damages caused by failure to exactly locate and preserve underground utilities. Replace damaged items with new material to match existing. Promptly notify Owner if utilities are found which are not shown on Drawings.
 - 2. Equipment: Unless otherwise directed, equipment, fixtures, or fittings being removed as part of demolition process are Owner's property. Remove other items not scheduled to be reused or relocated from job site as directed by Owner.

3. Unless specifically indicated on Drawings, remove exposed, unused piping to behind finished surfaces (floor, walls, ceilings, etc.). Cap piping and patch surfaces to match surrounding finish.
4. Unless specifically indicated on Drawings, remove unused equipment, fixtures, fittings, rough-ins, and connectors. Removal is to be to a point behind finished surfaces (floors, walls, and ceilings).

3.12 ACCEPTANCE

- A. Confirm requirements in Division 00, Procurement and Contracting Requirements and Division 01, General Requirements. In absence of specific requirements, comply with individual Sections in Division 22, Plumbing and the following:
 1. System cannot be considered for acceptance until work is completed and demonstrated to Architect that installation is in strict compliance with Specifications, Drawings and manufacturer's installation instructions, particularly in reference to following:
 - a. Testing and Balancing Reports
 - b. Cleaning
 - c. Operation and Maintenance Manuals
 - d. Training of Operating Personnel
 - e. Record Drawings
 - f. Warranty and Guaranty Certificates
 - g. Start-up/Test Document and Commissioning Reports

3.13 FIELD QUALITY CONTROL

- A. Confirm Field Quality Control requirements in Division 00, Procurement and Contracting Requirements, Division 01, General Requirements, Section 22 00 00, Plumbing Basic Requirements and individual Division 22, Plumbing Sections.
- B. Tests:
 1. Conduct tests of equipment and systems to demonstrate compliance with requirements specified. Reference individual Specification Sections for required tests. Document tests and include in operation and maintenance manuals.
 2. During site evaluations by Architect or Engineer, provide appropriate personnel with tools to remove and replace trims, covers, and devices so that proper evaluation of installation can be performed.

3.14 LETTER OF CONFORMANCE

- A. Provide Letter of Conformance, copies of manufacturers' warranties and extended warranties with a statement that plumbing items were installed in accordance with manufacturer's recommendations, UL listings and FM Global approvals. Include Letter of Conformance, copies of manufacturers' warranties and extended warranties in Operation and Maintenance Manuals.

3.15 ELECTRICAL INTERLOCKS

- A. Where equipment motors are to be electrically interlocked with other equipment for simultaneous operation, utilize plumbing equipment wiring diagrams to coordinate with electrical systems so that proper wiring of equipment involved is affected.

END OF SECTION

SECTION 22 0516 - EXPANSION FITTINGS AND LOOPS FOR PLUMBING PIPING

PART 1 - GENERAL

1.1 SUMMARY

- A. Work Included:
 - 1. Flexible Pipe Connectors, Copper Piping
 - 2. Flexible Expansion Loop (for Thermal and Seismic Applications), Copper Piping
 - 3. Expansion Joints, Two-Ply Bellows Type Copper Pipe

1.2 RELATED SECTIONS

- A. Contents of Division 22, Plumbing and Division 01, General Requirements apply to this Section.

1.3 REFERENCES AND STANDARDS

- A. References and Standards as required by Section 22 00 00, Plumbing Basic Requirements and Division 01, General Requirements.

1.4 SUBMITTALS

- A. Submittals as required by Section 22 00 00, Plumbing Basic Requirements and Division 01, General Requirements. Include items listed below.
- B. In addition, provide:
 - 1. Shop drawings for review and approval by Engineer. Illustrate Design Data and Expansion Joints items below on the Shop Drawing Submittal.
 - 2. Design Data: Indicate selection calculations.
 - 3. Expansion Joints: Indicate maximum temperature and pressure rating, and maximum expansion compensation.
 - 4. Project Record Documents: Record installed locations of flexible pipe connectors, expansion joints, anchors, and guides.
 - 5. Maintenance Materials: Furnish the following for Owner's use in maintenance of project.
 - a. Extra Packing for Packed Expansion Joints: One set for each joint.

1.5 QUALITY ASSURANCE

- A. Quality assurance as required by Section 22 00 00, Plumbing Basic Requirements and Division 01, General Requirements.

1.6 WARRANTY

- A. Warranty of materials and workmanship as required by Section 22 00 00, Plumbing Basic Requirements and Division 01, General Requirements.

PART 2 - PRODUCTS

2.1 MANUFACTURERS

- A. Flexible Pipe Connectors, Copper Piping:
 - 1. Mercer Rubber Company
 - 2. Metraflex Company
 - 3. Mason
 - 4. Hyspan
 - 5. Or approved equivalent.

- B. Flexible Expansion Loop (for Thermal and Seismic Applications), Copper Piping:
 - 1. Mercer Rubber Company
 - 2. Metraflex Company
 - 3. Mason
 - 4. Hyspan
 - 5. Or approved equivalent.

- C. Expansion Joints, Two-Ply Bellows Type Copper Pipe:
 - 1. Mercer Rubber Company
 - 2. Metraflex Company
 - 3. Mason
 - 4. Hyspan
 - 5. Or approved equivalent.

2.2 FLEXIBLE PIPE CONNECTORS - COPPER PIPING

- A. Inner Hose: Bronze, close pitch, annular corrugated hose.
- B. Exterior Sleeve: Braided bronze (piping over 2-inches to be 3 pound braided stainless steel).
- C. Pressure Rating: 125 PSI at 70 degrees F with a 4 to 1 safety factor.
- D. Joint: Sweat ends.
- E. Size: Use pipe sized units.
- F. Maximum offset: 3/8-inch on each side of installed center line.
- G. Basis of Design: Metraflex Model BBS.

2.3 FLEXIBLE EXPANSION LOOP (FOR THERMAL AND SEISMIC APPLICATIONS) - COPPER PIPING

- A. Construction: Two flexible Sections of hose and braid, two 90 degree elbows and a 180 degree return designed so piping does not change direction, but maintains course along a single axis. Use Vee Loop where space is limited. System to import no thrust loads to system support anchors or building structure.

- B. Inner Hose: Bronze, close pitch, annular corrugated hose.
- C. Exterior Sleeve: Braided bronze.
- D. Pressure Rating: 125 PSI at 70 degrees F with a 4 to 1 safety factor.
- E. Joint: Sweat ends.
- F. Size: Use pipe sized units.
- G. Support: Center support at bottom of 180 degree return.
- H. Basis of Design: Metraflex Metraloop. Vee configuration Mason-Mercer VCPSB.

2.4 EXPANSION JOINTS - TWO PLY BELLOWS TYPE COPPER PIPE

- A. Construction: Laminated bellows ASTM A240 Type 321 stainless steel, copper tube ASTM B88, ASTM A240 Type 321 stainless steel housing and guide, anti torque device, limit stops, internal guides
- B. Working Pressure: 200 PSI.
- C. Maximum Temperatures: 500 degrees F.
- D. Maximum Compression: 2-inches.
- E. Maximum Extension: 1/2-inch.
- F. Joint: Sweat ends. ASME B16.22.
- G. Size: Use pipe sized units. Maximum 4-inch pipe.
- H. Basis of Design: Hyspan Model 8509, 8510.

PART 3 - EXECUTION

3.1 GENERAL INSTALLATION REQUIREMENTS

- A. Expansion/Contraction Fitting Installation:
 - 1. Install expansion/contraction fittings according to manufacturer's written instructions.
 - 2. Install expansion/contraction fittings in sizes matching pipe size in which they are installed.
 - 3. Align expansion/contraction fittings to avoid end-loading and torsional stress.
 - 4. Install in accordance with EJMA (Expansion Joint Manufacturer's Association) Standards.
 - 5. Wood structures: install expansion/contraction fittings and guides at every floor.
 - 6. Concrete structures: install expansion/contraction fittings and guides at interval spacing recommended by the manufacturers.
- B. Pipe Bend and Loop Installation:

1. Install pipe bends and loops cold-sprung in tension or compression as required to partly absorb tension or compression produced during anticipated change in temperature.
 2. Attach pipe bends and loops to anchors.
 - a. Steel Anchors: Attach by welding. Comply with ASME B31.9 and ASME Boiler and Pressure Vessel Code Section IX, "Welding and Brazing Qualifications."
 - b. Concrete Anchors: Attach by fasteners. Follow fastener manufacturer's written instructions.
- C. Swing Connections:
1. Connect risers and branch connections to mains with at least five pipe fittings, including tee in main.
 2. Connect mains, risers and branch connections to equipment with at least four pipe fittings, including tee in riser.
- D. Guide Installation:
1. Install guides on piping adjoining expansion fittings and loops.
 2. Attach guides to pipe and secure to building structure.
- E. Anchor Installation:
1. Install anchors at locations to prevent stresses from exceeding those permitted by ASME B31.9 and to prevent transfer of loading and stresses to connected equipment.
 2. Fabricate and install steel anchors by welding steel shapes, plates, and bars to piping and to structure. Comply with ASME B31.9 and AWS D1.1.
 3. Construct concrete anchors of poured-in-place concrete of dimensions indicated and include embedded fasteners.
 4. Install pipe anchors according to expansion fitting manufacturer's written instructions if expansion fittings are indicated.
 5. Use grout to form flat bearing surfaces for expansion fittings, guides, and anchors installed on or in concrete.
- F. Painting:
1. Touch Up: Clean field welds and abraded areas of shop paint. Paint exposed areas immediately after erecting hangers and supports. Use same materials as used for shop painting. Comply with SSPC-PA1 requirements for touching up field-painted surfaces.
 - a. Apply paint by brush or spray to provide a minimum dry film thickness of 2.0 mils.
 2. Galvanized Surfaces: Clean welds, bolted connections, and abraded areas and apply galvanizing-repair paint to comply with ASTM A780.
- 3.2 FLEXIBLE PIPE CONNECTORS, COPPER PIPING
- A. See General Installation Requirements above.
 - B. Install per manufacturers written recommendations and requirements.
- 3.3 FLEXIBLE EXPANSION LOOP (FOR THERMAL AND SEISMIC APPLICATIONS), COPPER PIPING
- A. See General Installation Requirements above.

B. Install per manufacturers written recommendations and requirements.

3.4 EXPANSION JOINTS, TWO-PLY BELLOWS TYPE COPPER PIPE

A. See General Installation Requirements above.

B. Install per manufacturers written recommendations and requirements.

END OF SECTION

SECTION 22 0519 - PLUMBING DEVICES

PART 1 - GENERAL

1.1 SUMMARY

- A. Work Included:
 - 1. Pressure Gauges
 - 2. Thermometers
 - 3. Water Hammer Arrestors (Shock Absorbers)
 - 4. Trap Primers

1.2 RELATED SECTIONS

- A. Contents of Division 22, Plumbing and Division 01, General Requirements apply to this Section.

1.3 REFERENCES AND STANDARDS

- A. References and Standards as required by Section 22 00 00, Plumbing Basic Requirements and Division 01, General Requirements.

1.4 SUBMITTALS

- A. Submittals as required by Section 22 00 00, Plumbing Basic Requirements and Division 01, General Requirements.

1.5 QUALITY ASSURANCE

- A. Quality assurance as required by Section 22 00 00, Plumbing Basic Requirements and Division 01, General Requirements apply to this Section.

1.6 WARRANTY

- A. Warranty of materials and workmanship as required by Section 22 00 00, Plumbing Basic Requirements and Division 01, General Requirements.

PART 2 - PRODUCTS

2.1 MANUFACTURERS

- A. Pressure Gauges:
 - 1. Dwyer Instruments, Inc.
 - 2. Moeller Instrument Co., Inc.
 - 3. Omega Engineering, Inc.
 - 4. Terice
 - 5. Or approved equivalent.
- B. Thermometers:
 - 1. Ashcroft
 - 2. Terice

3. Weiss
4. Marshalltown
5. Weksler
6. Or approved equivalent.

C. Water Hammer Arrestors (Shock Absorbers):

1. Bellows Type:
 - a. Amtrol
 - b. J.R. Smith
 - c. Wade
 - d. Zurn
 - e. Or approved equivalent.
2. Piston Type:
 - a. PPP
 - b. Sioux Chief
 - c. Or approved equivalent.

D. Trap Primers:

1. Wade
2. Zurn
3. J.R. Smith
4. PPP
5. Or approved equivalent.

2.2 PRESSURE GAUGES

A. Pressure Gauges: ASME B40.100, phosphor-bronze bourdon type, dry type.

1. Case: Cast aluminum, stem-mounted, flange less.
2. Size: 4-1/2-inch diameter.
3. Window: Clear glass.
4. Connector: Brass.
5. Scale: White aluminum with black graduation and markings.
6. Pointer: Black, adjustable.
7. Mid-Scale Accuracy: One percent.
8. Scale: PSI and KPa.
9. Basis of Design: Trerice Model 600CB.

2.3 THERMOMETERS

A. Thermometers - Adjustable Angle: Red or blue appearing organic liquid in glass, ASTM E 1; lens front tube, cast aluminum case with enamel finish, cast aluminum adjustable joint with positive locking device; adjustable 360 degrees in horizontal plane, 180 degrees in vertical plane.

1. Size: 9-inch scale.
2. Window: Acrylic.
3. Scale: Aluminum, white background, black graduations and markings.
4. Stem: 3/4-inch NPT brass (aluminum for installation in air ducts).
5. Accuracy: 2 percent, per ASTM E 77.
6. Calibration: 0-160 with 2 Degrees F graduations.

7. Basis of Design: Trerice BX9.

2.4 WATER HAMMER ARRESTORS (SHOCK ABSORBERS)

- A. Bellows-type, stainless steel casing and bellows, pressure rated, tested and certified in accordance with PDI WH-201 or ASSE 1010.
- B. Piston-type, copper, brass or stainless steel with O-ring piston, pressure rated, tested and certified in accordance with PDI WH-201 or ASSE 1010.

2.5 TRAP PRIMERS

- A. Trap automatic primer valve with integral anti siphon protection. Code approval required.
- B. Flush valve tail-piece trap primer. PPP FVP-1VB.
- C. Electronic trap seal automatic primer valve with integral anti siphon protection and timer. Coordinate quantity, locations and voltage characteristics for control points.
- D. Trap seal primer valve (low lead) with integral automatic anti-siphon protection. The priming valve to discharge on both pressure drop and pressure spike. PPP CPO 500.

PART 3 - EXECUTION

3.1 GENERAL INSTALLATION REQUIREMENTS

- A. For plumbing devices requiring access from access panels (i.e. trap primers, water hammer arrestors and the like) submit location/size of all access panels to Architect for approval prior to purchase and installation of access panel. See Section 22 00 00, Plumbing Basic Requirements for additional requirements.
- B. Provide instruments with scale ranges selected according to service with largest appropriate scale.
- C. Install per manufacturer recommendations.

3.2 PRESSURE GAUGES

- A. Install pressure gauge where exposure to heat and vibration are minimal and where the dial can be easily read. It is also important to install the gauge in a location with undisturbed and continuous flow of the pressure medium.
- B. Provide a needle valve or gauge cock, installed between the process and the pressure gauges.
- C. Install pressure gauges in piping tee with pressure gauge cock, in locations where they are easily read from normal operating level. Install vertical to 45 degrees off vertical.
- D. Locations: Install in the following locations, and elsewhere as indicated.
 - 1. At each pump inlet and outlet.
 - 2. At inlet and discharge of each pressure reducing valve.
 - 3. At make-up water service outlets.

- E. Adjust gauges to final angle, clean windows and lenses, and calibrate to zero.
- F. Install per manufacturer recommendations.
- G. Pressure Gauge Range/Graduations:
 - 1. Cold Water: 0-100 PSI; graduation 1 PSI
 - 2. Hot Water: 0-100 PSI; graduation 1 PSI

3.3 THERMOMETERS

- A. Install thermometers in piping systems in sockets in short couplings. Enlarge pipes smaller than 2-1/2-inch for installation of thermometer sockets. Ensure sockets allow clearance from insulation.
- B. Install thermometers in locations where they are easily read from normal operating level. Install vertical to 45 degrees off vertical.
- C. Adjust thermometers to final angle, clean windows and lenses, and calibrate to zero.
- D. Install per manufacturer recommendations.
- E. Thermometer Range/Graduations:
 - 1. Cold Water: 25-125 degrees F; graduation 1 degree F
 - 2. Hot Water: 30-240 degrees F; graduation 2 degrees F

3.4 WATER HAMMER ARRESTORS (SHOCK ABSORBERS)

- A. Install in upright position, in locations and of sizes in accordance with PDI WH-201 or ASSE 1010, and elsewhere as indicated.
- B. Locate shock absorbers in supply pipe in accordance with recommendations of Plumbing and Drainage Institute PDI-WH201 or ASSE 1010. Install ahead of solenoid operated valves. Determine size of absorber by fixture unit value of fixture supplied, using PDI symbols to designate sizes. Provide access panel for each shock absorber.
- C. Install per manufacturer recommendations.

3.5 TRAP PRIMERS

- A. Flush supply line prior to installation.
- B. Install valve plumb using caution to not over tighten. Tightening to more than 55 ft. lbs. can damage valve and void the warranty. Do not wrench on hex.
- C. Effective operating range 20 to 80 PSIG (138 to 552 kPa).
- D. Do not subject trap primer valve to pressure in excess of 125 PSI.

END OF SECTION

SECTION 22 0523 - GENERAL-DUTY VALVES FOR PLUMBING PIPING

PART 1 - GENERAL

1.1 SUMMARY

A. Work Included:

1. Valves, General
2. Balancing Valves
3. Ball Valves
4. Swing Check Valves
5. Backflow Prevention Assemblies
6. Pressure Regulating Valve-Domestic Water
7. Thermostatic Master Mixing Valves (ASSE 1017 Rated)
8. Thermostatic Point-of-Use Mixing Valves (ASSE 1070 Rated)

1.2 RELATED SECTIONS

- A. Contents of Division 22, Plumbing and Division 01, General Requirements apply to this Section.

1.3 REFERENCES AND STANDARDS

- A. References and Standards as required by Section 22 00 00, Plumbing Basic Requirements and Division 01, General Requirements.

1.4 SUBMITTALS

- A. Submittals as required by Section 22 00 00, Plumbing Basic Requirements and Division 01, General Requirements.

1.5 QUALITY ASSURANCE

- A. Quality assurance as required by Section 22 00 00, Plumbing Basic Requirements and Division 01, General Requirements.
- B. In addition, meet the following:
1. NSF 61, Annex G and/or NSF/ANSI 372 for potable water services. Valves must be 3rd-party certified.
 2. ISO 9001 Certified.
 3. IAPMO Certified for Low Lead.
- C. Source Limitations for Valves: Obtain each type of valve from a single source and from a single manufacturer.
- D. Model numbers indicated as Basis-of-Design indicate valve characteristics. All valves are to meet code Low Lead/Lead Free Standards.

1.6 WARRANTY

- A. Warranty of materials and workmanship as required by Section 22 00 00, Plumbing Basic Requirements and Division 01, General Requirements.

PART 2 - PRODUCTS

2.1 MANUFACTURERS

- A. Source Limitations for Valves: Obtain each type of valve from a single source and from a single manufacturer.
- B. Valves, General:
 - 1. Apollo
 - 2. Armstrong
 - 3. ASCO
 - 4. Cla-Val
 - 5. Conbraco
 - 6. Crane
 - 7. Clow
 - 8. Griswold
 - 9. Hammond
 - 10. Hays
 - 11. Jenkins
 - 12. Josam
 - 13. Kennedy
 - 14. Milwaukee
 - 15. Mueller
 - 16. Nibco
 - 17. Red-White Valve
 - 18. Smith
 - 19. Stockham
 - 20. Tour Anderson
 - 21. Wade
 - 22. Watts
 - 23. Wilkins
 - 24. Zurn
 - 25. Or approved equivalent.
- C. Balancing Valves:
 - 1. Caleffi
 - 2. Griswold
 - 3. Hays
 - 4. Armstrong CBV
 - 5. Tour Anderson
 - 6. Or approved equivalent.
- D. Ball Valves:
 - 1. See Valves General above.

2. NSF Valves:
 - a. Clow
 - b. Kennedy
 - c. Nibco
 - d. Or approved equivalent.

- E. Swing Check Valves:
 1. See Valves General above.

- F. Backflow Prevention Assemblies:
 1. Backflow Preventers:
 - a. Apollo
 - b. Cla-Val
 - c. Conbraco
 - d. Watts
 - e. Or approved equivalent.
 2. Backflow Prevention Assemblies - Reduced Pressure Zone Backflow Preventer (RPBP) for High Hazard Applications - 2-inches and Smaller:
 - a. Febco 860-with 650A.
 - b. Conbraco 40-210-AGD.
 - c. Wilkins 375-XL-SAG.
 - d. Watts 919-QT-S valve with 919AGC or 919AGF.
 - e. Or approved equivalent.
 3. Backflow Prevention Assemblies - Reduced Pressure Zone Backflow Preventer (RPBP) for High Hazard Applications - 2-1/2-inches and Larger:
 - a. Febco 860 with 758A.
 - b. Conbraco Apollo 40-700 with 758A.
 - c. Watts 909-S-NFA-NRS with AGC.
 - d. Wilkins 375-FSC.
 - e. Or approved equivalent.
 4. Backflow Prevention Assemblies - Double Check Valve Assembly (DCVA) for Low Hazard Applications - 2-inches and smaller:
 - a. Febco 850-650A
 - b. Conbraco Apollo 40-110-T2
 - c. Watts 007-QT-FDA-S
 - d. Wilkins 350-S-XL
 - e. Or approved equivalent.
 5. Backflow Prevention Assemblies - Double Check Valve Assembly (DCVA) for Low Hazard Applications - 2-1/2-inches and larger:
 - a. Conbraco Apollo 45-11-1
 - b. Watts LF-709 with 77F-01-FDA-12
 - c. Or approved equivalent.
 6. Spill Resistant Pressure Vacuum Breaker:
 - a. Febco
 - b. Conbraco
 - c. Watts
 - d. Wilkins
 - e. Or approved equivalent.
 7. Atmospheric Vacuum Breakers:

- a. Febco
- b. Conbraco
- c. Watts
- d. Wilkins
- e. Or approved equivalent.

G. Pressure Regulating Valve-Domestic Water:

1. Cash Acme
2. Cla-Val
3. Watts
4. Wilkins
5. Or approved equivalent.

H. Thermostatic Master Mixing Valves (ASSE 1017 Rated):

1. Holby Tempering Valve
2. Lawler Series 66
3. Leonard Type TM
4. Powers LFMM430 (Lead Free)
5. Symmons Temp Control Series 5
6. Or approved equivalent.

I. Thermostatic Point-of-Use Mixing Valves (ASSE 1070 Rated):

1. Lawler
2. Leonard
3. Powers Hydroguard
4. Or approved equivalent.

2.2 VALVES - GENERAL

A. General:

1. Sizes: Unless otherwise indicated, provide valves of same size as upstream pipe size.
2. Operators: Provide handwheels, fastened to valve stem, for valves other than quarter-turn. Provide lever handle for quarter-turn valves 6-inches and smaller. Provide gear operators for quarter-turn valves 8-inches and larger and plug valves installed over 5-feet above finished floor.
3. Valve Identification: Manufacturer's name (or trademark) and pressure rating clearly marked on valve body.

B. Valves in Insulated Piping: With 2-inch stem extension and following features:

1. Ball Valves: With extended operating handle of non-thermal-conductive material, and protective sleeve that allows operation on valve without breaking the vapor seal or disturbing insulation and memory stops that are fully adjustable after insulation is applied.

C. Valve-End Connections:

1. Flanged: With flanges according to ASME B16.1 for iron valves.
2. Solder Joint: With sockets according to ASME B16.18.
3. Threaded: With thread according to ASME B1.20.1.

D. Valve Bypass and Drain Connections: MSS SP-45.

- E. Building Service:
 - 1. Shutoff and Isolation Valves:
 - a. Pipe Sizes 3-inches and Smaller: Ball Valve.
 - 2. Drain Service: Ball Valves.
 - 3. Strainer Blow-Off: Ball Valve.
 - 4. Check Valves: Swing.

2.3 BALANCING VALVES

- A. Maximum 125 PSIG System Working Water Pressure.
- B. Manual Set Balancing Valves:
 - 1. Valves are to be of the "Y" pattern, equal percentage globe-style and provide three functions:
 - a. Precise flow measurement.
 - b. Precision flow balancing.
 - c. Positive drip-tight shut-off.
 - 2. Valve to provide multi-turn, 360 degree adjustment with micrometer type indicators located on the valve handwheel. Valves have a minimum of five full 360 degree handwheel turns. 90 degree circuit-setter style ball valves are not acceptable. Valve handle to have hidden memory feature, which will provide a means for locking the valve position after the system is balanced. Valves to be furnished with precision machined venturi built into the valve body to provide highly accurate flow measurement and flow balancing. The venturi to have two 1/4-inch threaded brass metering ports with check valves and gasketed caps located on the inlet side of the valve. Valves to be furnished with flow smoothing fins downstream of the valve seat and integral to the forged valve body to make the flow more laminar. The valve body, stem and plug to be brass. The handwheel to be high-strength resin.
 - 3. 2-1/2-inch and Larger: Valves are to be of the "Y" pattern, equal percentage globe-style and provide three functions:
 - a. Precise flow measurement.
 - b. Precision flow balancing.
 - c. Positive drip-tight shut off. Valve to provide multi-turn, 360 degree adjustment with micrometer type indicators location on the valve handwheel. Valves to have a minimum of five full 360 degree handwheel turns. 90 degree circuit-setter style ball valves are not acceptable. Valve handle to have hidden memory feature, which will provide a means for locking the valve position after the system is balanced. Valve body to be either cast iron with integrated cast iron flanges (2-1/2-inch to 12-inch) or ductile iron with industrial standard grooved ends (2-1/2-inch to 12-inch). Valve stem and plug disc to be bronze with handwheel that permits multi-turn adjustments. Sizes 2-1/2-inch and 3-inch - five turns, sizes 4-inch to 6-inch - 6 turns, sizes 8-inch to 10-inch - 12 turns and size 12-inch - 14 turns. Flange adapters to be provided to prevent rotation.

2.4 BALL VALVES

- A. All ball valves on brazed piping are to be three-piece.

- B. 2-1/2 Inches and Smaller: MSS SP-110, 400-600 PSI, two-piece full port ball configuration, bronze body, extended soldered ends for copper pipe and threaded ends for iron pipe, lead-free brass or stainless steel ball, lead-free brass stem, Teflon seat, extended steel handle. Apollo 77CLF 100 Series two-piece.
- C. 3 Inches and Larger: MSS SP-110, 400-600 PSI, three-piece full port ball configuration, bronze body, extended soldered ends for copper pipe and threaded ends for iron pipe, lead-free brass or stainless steel ball, lead-free brass stem, Teflon seat, extended steel handle. Apollo 82-100/82A 140 Series three-piece.
- D. Full Port Ball Valve: 2- to 4-inch ductile iron, ASTM A536, micro finish steel chrome plated or stainless steel ball and stem. TFE seats, 600 PSI.

2.5 SWING CHECK VALVES

- A. 2-inches and Smaller: Class 125, bronze body, horizontal swing, regrinding type, Y-pattern, renewable disc. Nibco 413. MSS SP-80.
- B. 2-1/2-inches and Larger: Class 125, iron body, bolted bonnet, horizontal swing, renewable seat and disc, flanged ends. Nibco F918. MMS SP-71.
- C. Rubber Flapper Check Valve: Horizontal or vertical upward flow installation. Working pressure to 175 PSI. Ductile iron or cast iron body. Steel reinforced Buna-N rubber flapper epoxy coating on wetted parts. MSS SP-80.
- D. Gruvlok Series 7800 Check Valve: Horizontal installation. Working pressure to 300 PSI, Type 304/302 Stainless Steel conforming to ASTM 167. Ductile body, ASTM A536, and stainless clapper, EPDM, nitrile or optional viton bumper and bonnet seals. Stainless wetted parts.

2.6 BACKFLOW PREVENTION ASSEMBLIES

- A. General: Assemblies model numbers listed below are for general comparison. Project specific model numbers to be verified contractor as approved by jurisdiction where project is located.
- B. Reduced Pressure Zone Backflow Preventer (RPBP) for High Hazard Applications:
 - 1. 2-inches and Smaller: Assembly consists of shutoff ball valves in inlet and outlet, and strainer on inlet. Assemblies include test cocks and pressure-differential relief valve located between two positive seating check valves and comply with requirements of ASSE Standard 1013 and AWWA C511. Bronze construction, threaded ends, stainless steel internal parts, FDA strainer, and air gap fitting. Route pipe from air gap fitting to approved waste receptor.
 - 2. 2-1/2-inches and Larger: Assembly consists of shutoff OS&Y gate valves in inlet and outlet, and strainer on inlet. Assemblies include test cocks and pressure-differential relief valve located between two positive seating check valves and comply with requirements of ASSE Standard 1015 and AWWA C511. Epoxy coated cast iron body construction, flanged ends, stainless steel internal parts, bronze seats, and FDA strainer.
- C. Double Check Valve Assembly (DCVA) for Low Hazard Applications:
 - 1. 2-inches and Smaller: Assembly consists of shutoff ball valves in inlet and outlet, and FDS strainer on inlet. Assemblies include test cocks and two positive seating check

valves and comply with requirements of ASSE Standard 1015 and AWWA C510. Bronze construction, threaded ends, and stainless steel internal parts.

2. 2-1/2-inches and Larger: Assembly consists of shutoff OS&Y gate valves in inlet and outlet, and strainer on inlet. Assemblies include test cocks and two positive seating check valves and comply with requirements of ASSE Standard 1015 and AWWA C510. Epoxy coat cast iron body construction, strainer flanged ends, and stainless steel internal parts.

- D. Spill Resistant Pressure Vacuum Breaker: Watts Model 800MCQT with 777S "Y" strainer.
- E. Atmospheric Vacuum Breaker: Assembly consists of a bronze vacuum breaker body with silicone disc, and full size orifice. Device to be IAPMO listed, meet ASSE standard 1001, and ANSI standard A113.1.1 rough chrome plate finish.

2.7 PRESSURE REGULATING VALVE-DOMESTIC WATER

- A. Water: Bronze body, diaphragm or piston type, spring actuated, with separate or integral stainless steel strainer, pressure range to suit conditions, approved for potable water use, low lead. Provide shutoff valves, pressure relief valves, unions, drain valve and bypass.
- B. Water: Automatic control pressure regulating valve, stainless steel seat, stem and spring, diaphragm actuated with brass body, hydraulic control pilots with effluent operating temperature range 32 degrees F to 180 degrees F, FDA and AWWA approved.
- C. Water: Bronze body construction, stainless steel strainer screen, thermal expansion bypass with renewable stainless steel seat and high temperature resisting diaphragm.

2.8 THERMOSTATIC MASTER MIXING VALVES (ASSE 1017 RATED)

- A. Thermostatic type with bronze body construction, corrosion resistant materials, union end stops, check inlets with strainers, 0-200 degree F dial thermometer and discharge shut-off valve. Mixing valves to meet ASSE 1017.
- B. Maximum required delta temperature differential between hot water supply temperature and delivery temperature is 15 degrees F. Set valve outlet temperature per drawing requirements.
- C. Flow from the tempered water circulating pump to be split to mixing valve and building hot water heating system.

2.9 THERMOSTATIC POINT-OF-USE MIXING VALVES (ASSE 1070 RATED)

- A. Thermostatic type with bronze body construction, corrosion resistant materials, union end stops, check inlets with strainers, 0-200 degree F dial thermometer and discharge shut-off valve. Mixing valves to meet ASSE 1070.
- B. Maximum required delta temperature differential between hot water supply temperature and delivery temperature is 15 degrees F. Set valve outlet temperature per drawing requirements.

PART 3 - EXECUTION

3.1 GENERAL INSTALLATION REQUIREMENTS

- A. Prepare valves for shipping as follows:
 - 1. Protect internal parts against rust and corrosion.
 - 2. Protect threads, flange faces, grooves, and weld ends.
 - 3. Set ball valves open to minimize exposure of functional surfaces.
 - 4. Block check valves in either closed or open position.
- B. Use the following precautions during storage:
 - 1. Maintain valve end protection.
 - 2. Store valves indoors and maintain at higher than ambient dew-point temperature. If outdoor storage is necessary, store valves off the ground in watertight enclosures.
- C. Inspect the shipping container before unpacking to look for damage that could have occurred during transport, and report it to the transportation company immediately. After visual inspection, remove the valve from the shipping container. Make sure the faces are free of any scratches and that there is not any obvious damage to the actuator assembly or valve body.
- D. Make sure to note the valve's model number during the unpacking process. The model number will need to be provided when purchasing replacement parts.
- E. Purge and clean all piping to be connected to valve.
- F. Install per manufacturer's recommendations.
- G. Determine that the valve and its plumbing piping is adequately supported when installed. If a valve is not adequately supported, this could prevent the valve from operating and sealing correctly. Be sure that all mating flanges are in line and parallel to minimize straining on joints and valve body.
- H. Use sling to handle large valves; rig sling to avoid damage to exposed parts. Do not use handwheels or stems as lifting or rigging points.
- I. Do not attempt to repair defective valves; replace with new valves.
- J. Install valves where required for proper operation of piping and equipment, including valves in branch lines where necessary to isolate sections of piping. Locate valves so as to be accessible and so that separate support can be provided when necessary.
- K. Install valves with stems pointed up, in vertical position where possible, but in no case with stems pointed downward from horizontal plane unless unavoidable. Install valve drains with hose end adapter and cap on chain for each valve that must be installed with stem below horizontal plane. Ensure installation provides full stem movement.
- L. Insulation: Where insulation is indicated, install extended stem valves, arranged in proper manner to receive insulation.

- M. Mechanical Actuators: Install with chain operators where indicated. Extend chains to 5-feet above floor and hook to clips to clear aisle passage.
 - N. Stem Selection: Outside screw and yoke stems, except provide inside screw, non-rising stem where space prevents full opening of OS&Y valves.
 - O. Seats: Renewable seats, except where otherwise indicated.
 - P. When soldering, use paste flux that are approved by the manufacturer for use with lead free alloys.
 - Q. If valve applications are not indicated on Drawings, use the following:
 - 1. Shutoff Service: Ball valves.
 - R. If valves with specified SWP classes or CWP ratings are not available, the same types of valves with higher SWP classes or CWP ratings may be substituted.
 - S. Valves, except wafer/butterfly types, with the following end connections:
 - 1. For Copper Tubing, 2-inches and Smaller. Threaded ends except where solder-joint valve-end.
 - 2. For Copper Tubing, 2-1/2-inches to NPS 4-inches. Flanged ends except where threaded valve-end.
 - 3. For Copper Tubing: 5-inches and Larger: Flanged ends.
 - 4. For Steel Piping, 2-inches and Smaller: Threaded ends.
 - 5. For Steel Piping, 2-1/2-inches to NPS 4-inches: Flanged ends except where threaded valve-end.
 - 6. For Steel Piping, 5-inches and Larger: Flanged ends.
 - T. Valve Adjusting and Cleaning:
 - 1. Inspect valves for leaks. Adjust or replace packing to stop leaks. Replace valve if leak persists.
 - 2. Valve Identification. Tag valves per Section 22 05 53, Identification for Plumbing Piping and Equipment.
- 3.2 BALANCING VALVES
- A. See General Installation Requirements above.
 - B. Install with flow in the direction of the arrow on the valve body and installed at least five pipe diameters downstream from any fitting, and at least ten pipe diameters downstream from any pump. Two pipe diameters downstream from the balancing valve should be free of any fittings. When installed, easy and unobstructed access to the valve handwheel and metering ports for adjustment and measurement are to be provided. Mounting of valve in piping must prevent sediment build-up in metering ports.
- 3.3 BALL VALVES
- A. See General Installation Requirements above.

3.4 SWING CHECK VALVES

- A. See General Installation Requirements above.
- B. Swing Check Valve Installation: Install in horizontal position with hinge pin horizontally perpendicular to centerline of pipe. Install for proper direction of flow. Only install where there are 10 pipe diameters of straight pipe upstream of valve.
- C. Ejector and Sump Pump-Discharge Check Valves:
 - 1. 2-inches and Smaller: Bronze swing or spring-loaded lift check valves with bronze disc.
 - 2. 2-1/2-inches and Larger: Rubber flapper swing check valves with lever and weight.
- D. Domestic Water and Circulation Pump Discharge Check Valves:
 - 1. 2-inches and Smaller: Bronze body, spring loaded, lead free, lift check.
 - 2. 2-1/2-inches and Larger: Wafer style, silent lift check valve, lead free.

3.5 BACKFLOW PREVENTION ASSEMBLIES

- A. See General Installation Requirements above.
- B. Install where indicated, and where required by code. Where practical, locate in same room as equipment being protected.
- C. Submit product cut sheets to local AHJ for approval prior to purchase and installation.
- D. Install as close to wall as possible with clearances for access and maintenance as required by AHJ.
- E. Coordinate exact location of installation and type of backflow device serving a particular piece of equipment with AHJ and Architect prior to purchase and installation.
- F. Provide wall/floor brackets that are of fully welded, hot dipped galvanized construction, fabricated to meet field conditions. Mount backflow preventer to brackets using cadmium plated "U" type bolts and nuts.
- G. Contact local water district/backflow specialist and request backflow installation requirements. Install backflow devices per UPC and local water district/backflow specialist requirements.
- H. Route waste piping from air gap waste fitting concealed within walls to point of air gap termination at indirect waste receptor.
- I. Follow local codes for installation requirements. Pipe lines should be thoroughly flushed to remove foreign material before installing the unit. Provide a strainer ahead of backflow preventer to prevent disc from unnecessary fouling. Install valve in line with arrow on valve body pointing in the direction of flow. It is important that the valve be easily accessible to facilitate testing and servicing. Do not install in a concealed location.

3.6 PRESSURE REGULATING VALVE-DOMESTIC WATER

- A. See General Installation Requirements above.

- B. Install valve in the line with arrow on valve body pointing in the direction of flow. This valve should be installed where it is accessible with sufficient clearance for cleaning, service or adjustment. Install the reducing valve before a sill cock line if possible. Before installing the reducing valve hose bibb, flush out the line to remove loose dirt and scale which might damage valve disc and seat.
 - C. Horizontal installation is recommended. However, valve can be installed in a vertical position. Regulator must be installed in an accessible location to facilitate servicing the regulator.
 - D. To readjust reduced pressures, loosen adjusting screw nut and turn adjusting screw clockwise to raise reduced pressure and counterclockwise to lower reduced pressure.
 - E. When reducing valve is used, it makes a closed system; therefore, pressure relief protection must be provided on the downstream side of the reducing valve to protect equipment.
 - F. Provide pressure relief valve and terminate discharge to indirect waste receiver.
 - G. Anytime a reducing valve is adjusted, the use of a pressure gauge is recommended to verify correct pressure setting. Do not bottom out adjusting screw or spring cage.
 - H. Provide inlet and outlet ball valves, and globe valve bypass. Provide pressure gauge on valve outlet.
 - I. Provide pressure relief valve piped full size to indirect waste receiver or floor drain.
 - J. Provide factory startup on automatic control valves.
- 3.7 THERMOSTATIC MASTER MIXING VALVES (ASSE 1017 RATED)
- A. See General Installation Requirements above.
 - B. Install mixing valve per manufacturer's instruction manual.
- 3.8 THERMOSTATIC POINT-OF-USE MIXING VALVES (ASSE 1070 RATED)
- A. See General Installation Requirements above.
 - B. Install mixing valve per manufacturer's instruction manual.

END OF SECTION

SECTION 22 0529 - HANGERS AND SUPPORTS FOR PLUMBING PIPING AND EQUIPMENT

PART 1 - GENERAL

1.1 SUMMARY

A. Work Included:

1. Pipe Hangers and Supports for Plumbing Piping and Equipment
2. Wall and Floor Sleeves
3. Building Attachments
4. Flashing
5. Miscellaneous Metal and Materials

1.2 RELATED SECTIONS

- ##### A. Contents of Division 22, Plumbing and Division 01, General Requirements apply to this Section.

1.3 REFERENCES AND STANDARDS

- ##### A. References and Standards as required by Section 22 00 00, Plumbing Basic Requirements and Division 01, General Requirements.
- ##### B. In addition, meet the following:
1. ASCE 7-10, Minimum Design Loads for Buildings and Other Structures.
 2. Hanger spacing installation and attachment to meet all manufacturer's requirements and MSS SP-58.
 3. Terminology: As defined in MSS SP-90 "Guidelines on Terminology for Pipe Hangers and Supports".
 4. Install piping per SMACNA's requirements.

1.4 SUBMITTALS

- ##### A. Submittals as required by Section 22 00 00, Plumbing Basic Requirements and Division 01, General Requirements.

1.5 QUALITY ASSURANCE

- ##### A. Quality assurance as required by Section 22 00 00, Plumbing Basic Requirements and Division 01, General Requirements.

1.6 WARRANTY

- ##### A. Warranty of materials and workmanship as required by Section 22 00 00, Plumbing Basic Requirements and Division 01, General Requirements.

1.7 PERFORMANCE REQUIREMENTS

- ##### A. General - Provide pipe and equipment hangers and supports in accordance with the following:

1. When supports, anchorages, and seismic restraints for equipment, and supports, anchorages, and seismic restraints for piping are not shown on the Drawings, the contractor is responsible for their design.
 2. Connections to structural framing are not to introduce twisting, torsion, or lateral bending in the framing members. Provide supplementary steel as required.
- B. Engineered Support Systems:
1. Support frames such as pipe racks or stanchions for piping and equipment which provide support from below.
 2. Equipment and piping support frame anchorage to supporting slab or structure.
- C. Provide channel support systems, for piping to support multiple pipes capable of supporting the combined weight of supported systems, system contents and test water.
- D. Provide heavy-duty steel trapezes for piping to support multiple pipes capable of supporting the combined weight of supported systems, system contents and test water.
- E. Provide seismic restraint hangers and supports for piping and equipment.
- F. Obtain approval from AHJ for seismic restraint hanger and support system to be installed for piping and equipment.

PART 2 - PRODUCTS

2.1 MANUFACTURERS

- A. Pipe Hangers and Supports for Plumbing Piping and Equipment:
1. Pipe Hangers/Supports:
 - a. B-Line Systems, Inc.
 - b. Anvil International
 - c. HOLDRITE
 - d. Erico Co., Inc.
 - e. Snappitz Thermal Pipe Shield Manufacturing
 - f. Rilco Manufacturing Co. Inc.
 - g. Nelson-Olson Inc.
 - h. Or approved equivalent.
 2. Channel Support Systems:
 - a. B-Line Systems, Inc.
 - b. Anvil International, Anvit-Strut
 - c. Erico Hanger Co., Inc.; O-Strut Div.
 - d. Unistrut Corp.
 - e. HOLDRITE EZ-Strut Systems
 - f. Or approved equivalent.
 3. Thermal-Hanger Shield Inserts:
 - a. Erico Hanger Co., Inc.
 - b. Pipe Shields, Inc.
 - c. Rilco Manufacturing Co., Inc.
 - d. HOLDRITE Insulation Couplings
 - e. Or approved equivalent.
 4. Freestanding Roof Supports:

- a. Erico Hanger Co., Inc.
 - b. Nelson-Olsen Inc.
 - c. B-Line
 - d. M. Fab
 - e. Or approved equivalent.
5. Pipe Alignment and Secondary Supports:
- a. HOLDRITE
 - b. Starquick
 - c. Or approved equivalent.
- B. Wall and Floor Sleeves:
1. Below Grade and High Water Table Areas:
 - a. Modular Link Sealing System at Pipe Sleeves:
 - 1) Thunderline Corporation
 - 2) Or approved equivalent.
 2. Pre-Engineered Firestop Pipe Penetration Systems:
 - a. HOLDRITE HydroFlame
 - b. Proset
 - c. Or approved equivalent.
- C. Building Attachments:
1. Anchor-It
 2. Gunnebo Fastening Corp.
 3. ITW Ramset/Red Head
 4. Masterset Fastening Systems, Inc.
 5. Or approved equivalent.
- D. Flashing:
1. Fastenal
 2. Or approved equivalent.
- E. Miscellaneous Metal and Materials:
1. See Miscellaneous Metal and Materials article below.
 2. Powder-Actuated Fastener Systems:
 - a. Gunnebo Fastening Corp.
 - b. Hilti, Inc.
 - c. ITW Ramset/Red Head.
 - d. Masterset Fastening Systems, Inc.
 - e. Or approved equivalent.
- 2.2 PIPE HANGERS AND SUPPORTS FOR PLUMBING PIPING AND EQUIPMENT
- A. Horizontal Piping Hangers and Supports - Horizontal and Vertical Piping, and Hanger Rod Attachments:
1. Factory fabricated horizontal piping hangers and supports to suit piping systems in accordance manufacturer's published product information.
 2. Use only one type by one manufacturer for each piping service.
 3. Select size of hangers and supports to exactly fit pipe size for bare piping and to exactly fit around piping insulation with saddle or shield for insulated piping.

4. Provide copper-plated hangers and supports for uninsulated copper piping systems.
 5. Provide padded pipe hangers, clamps and supports for thermoplastic piping system.
 6. Install no hub cast iron pipe and fittings per CISPI 301-09 Installation Procedures for Hubless Cast Iron Pipe and Fittings for Sanitary and Storm Drain Waste and Vent Piping Applications. Brace hubless cast iron pipe and fittings 5-inch and larger with HOLDRITE No Hub Pipe Restraints or approved equivalent.
- B. Pipe Hangers, Guides and Channel Systems:
1. Hanger Rods: Hanger rods continuously threaded or threaded ends only in concealed spaces and threaded ends only in exposed spaces; finish electro-galvanized or cadmium-plated in concealed spaces and prime painted in exposed spaces; sizes per MSS.
 2. Hanger Rod Couplings: Malleable iron rod coupling with elongated center sight gap for visual inspection; to have same finish as hanger rods.
 3. Pipe Rings for Hanger Rods: Pipe sizes 2-inch and smaller, MSS SP Type 6 or Type 10, or approved equivalent. Pipe sizes 2-1/2-inches and larger, clevis type hangers with adjustable nuts on rod. MSS SP Type 1. Pipe rings to have same finish as hanger rods.
 4. Pipe Slides: Type 35 reinforced Teflon slide material (3/32-inch minimum thickness) bonded to steel; highly finished steel or stainless steel contact surfaces to resist corrosion; 60-80 PSI maximum active contact surface loading; steel parts 3/16-inch minimum thickness; attachment to pipe and framing by welding.
 5. Pipe Guides:
 - a. Furnish and install pipe guides on continuous runs where pipe alignment must be maintained. Minimum two on each side of expansion joints, spaced per manufacturer's recommendations for pipe size. Fasten guides securely to pipe and structure. Any contact with chilled water pipe is not to permit heat to be transferred in sufficient quantity to cause condensation on any surface.
 - b. Furnish and install guides approximately 4 pipe diameters (first guide) and 14 diameters (second guide) away from each end of expansion joints. Guides are not to be used as supports and are in addition to other pipe hangers and supports.
 6. Channel Type Pipe Hanging System: Framing members No. 12 gauge formed steel channels, 1-5/8-inch square, conforming to ASTM A570 GR33; one side of channel to have a continuous slot with in-turned lips; framing nut with grooves and spring 1/2-inch size, conforming to ASTM 675 GR60; screws conforming to ASTM A307; fittings conforming to ASTM A575; parts enamel painted or electro-galvanized.
- C. Pipe Saddles and Shields:
1. Factory fabricated saddles or shields under piping hangers and supports for insulated piping.
 2. Size saddles and shields for exact fit to mate with pipe insulation. 1/2 round, 18 gauge, minimum 12-inches in length (4-inch pipe and larger to be three times longer than pipe diameter).
- D. Thermal-Hanger Shield Inserts: 100-PSI (690-kPa) minimum compressive strength insulation, encased in sheet metal shield.
1. Material for Cold Piping: Water-repellent-treated, ASTM C533, Type I calcium silicate with vapor barrier.
 2. Material for Hot Piping: Water-repellent-treated ASTM C533, Type 1 calcium silicate.
 3. For Trapeze or Clamped System: Insert and shield cover entire circumference of pipe.
 4. For Clevis or Band Hanger: Insert and shield to cover lower 180 degrees of pipe.

5. Insert Length: Extend 2-inches beyond sheet metal shield for piping operating below ambient air temperature.
 6. Thermal Hanger Shield Inserts should be provided at the hanger points and guide locations on pipes requiring insulation. The Inserts should consist of Polyisocyanurate (urethane or phenolic insulation) encircling the entire circumference of the pipe with a 360 degree PVC (1.524 mm thick) with a living hinge and J lock and installed during the installation of the piping system.
- E. Roller Hangers:
1. Adjustable roller hanger. Black steel yoke, cast iron roller. MSS Type 41.
- F. Concrete Inserts:
1. Malleable iron body, hot dipped galvanized finish. Lateral adjustment. MSS Type 18.
- G. Continuous Concrete Insert:
1. Steel construction, minimum 12 gauge. Electrogalvanized finish. Pipe clamps and insert nuts to match.
- H. Beam Clamps:
1. MSS Type 19 and 23, wide throat, with retaining clip.
 2. Universal Side Beam Clamp: MSS Type 20.
- I. Below Ground:
1. Pipe Hangers: Adjustable Clevis type, Federal Specification WW-H-171 (Type 1), UL listed, stainless steel Type 316. MSS Type 1. If PVC piping to be used, provide Type 1 hanger, coated for PVC piping.
 2. Rod: 5/8-inch stainless steel Type 316.
 3. Eyebolt: Stainless steel Type 316.
 4. Nuts and Washers: Stainless steel Type 316.
- J. Hangers for Pipe Size 2-inches and Smaller:
1. Adjustable swivel ring hanger, UL listed, Type 6 or Type 10.
- K. Hangers for Pipe Size 2-1/2-inches and Larger:
1. Adjustable clevis type, UL listed, Type 1.
- L. Riser Clamps:
1. Steel, UL listed. MSS Type 8.
- M. Plumbers Tape:
1. Not permitted as pipe hangers or pipe straps.
- N. Pipe Alignment and Secondary Support Systems:
1. Secondary Pipe supports for general applications (Non-Acoustical).
 - a. Supports will be manufactured in compliance with IAPMO Product Standard PS 42-96. All products provided will be listed by IAPMO for secondary pipe support.
 - b. Supports may be used when sound and/or vibration transfer is not a concern.
 2. Secondary pipe supports for sound and vibration attenuation (Acoustical).
 - a. Supports will be manufactured in compliance with IAPMO Product Standard PS 42-96. All products provided will be listed by IAPMO for secondary pipe support.

- b. Acoustical pipe supports will be manufactured and installed in compliance with International Organization for Standardization (ISO) 3822-1 with current amendments.
- c. Supports will be used when sound and/or vibration transfer is a concern. Locations where acoustical supports will be provided and include but are not limited to partition walls between living units, tenant spaces, retail units, mechanical rooms and lobbies.
- d. Support Products:
 - 1) Support to Wall Brace and Wall Stud Penetrations: HOLDRITE #261, #262, #263, and #264, or approved equivalent.
 - 2) Pipe Wrap for Pipe Clamps and Channel-Mounted Pipe Clamps: HOLDRITE #270, or approved equivalent.
 - 3) Pipe Wrap for Pipe Hangers: HOLDRITE #271, #272-2, and #272-4, or approved equivalent.
 - 4) Drop-Ear Fitting Support: HOLDRITE #265, or approved equivalent.
 - 5) Floor Riser Isolation Pads: HOLDRITE #275-T, or approved equivalent.
 - 6) Floor Isolation Pads (General Applications): HOLDRITE #274, #275, #276, and #278, or approved equivalent.

O. Freestanding Roof Pipe Supports:

- 1. Polyethylene high-density U.V. resistant quick "pipe" block with foam pad.
- 2. Recommended installation is for pipe blocks to be freestanding.
- 3. Piping 3-inches and larger mounted on block type supports.

2.3 WALL AND FLOOR SLEEVES

A. Below Grade and High Water Table Areas:

- 1. Modular Link Sealing System at Pipe Sleeves: Neoprene gasket links bolted together around an interior sleeve forming a watertight seal. Use a modular link sealing system at sleeves to continuously fill the annular space between the pipe and the wall opening. Provide Link-seal Type C unless otherwise noted. OS with S-316 stainless construction for continuous water/tank walls.
- 2. Sleeves through concrete foundation walls and floors. Ductile iron pipe. Class 50 or 51 pipe conforming to ANSI/AWWA C151/A21.51, cement lined. Pipe sleeve will extend a minimum of 6-inches beyond outside perimeter of foundation. Final placement of sleeve will be confirmed with project's structural engineer. In areas with a high water table, provide AWWA C900, Class 235 plastic pipe in lieu of ductile iron pipe.

B. Pre-Engineered Firestop Pipe Penetration Systems: UL listed assemblies for maintaining fire rating of piping penetrations through fire-rated assemblies. Comply with ASTM E814.

C. Insulating Caulking: Eagle or Pitcher Super 66 high temperature cement.

D. Fabricated Accessories:

- 1. Steel Pipe Sleeves: Fabricate from Schedule 40 black or galvanized steel pipe. Remove end burrs by grinding.
- 2. Sheet Metal Pipe Sleeves: Fabricate from G-90 galvanized sheets closed with lock-seam joints. Provide following minimum gauges for sizes indicated:
 - a. Sleeve Size 4-inches in Diameter and Smaller: 18 gauge.
 - b. Sleeve Sizes 5-inches to 6-inches: 16 gauge.

- c. Sleeve Sizes 7-inches and Larger: 14 gauge.
- d. Fire-Rated Safing Material:
 - 1) Rockwool Insulation: Complying with FS-HH-I-558, Form A, Class IV, 6 lbs./cu.ft. density with melting point of 1985 degrees F and K value of 0.24 at 75 degrees F.
 - 2) Calcium Silicate Insulation: Noncombustible, complying with FS-HH-I-523, Type II, suitable for 100 degrees F to 1200 degrees F service with K value of 0.40 at 150 degrees F.

2.4 BUILDING ATTACHMENTS

- A. General: Anchor supports to existing masonry, block and tile walls per anchoring system manufacturer's recommendations or as modified by project Structural Engineer. Provide anchor bolts suitable for cracked concrete.
- B. Anchor Bolts:
 - 1. Anchor Bolts (Cast-In-Place): Steel bolts, ASTM A307. Nuts to conform to ASTM A194. Design values for shear and tension not more than 80 percent of the allowable listed loads.
 - 2. Anchor (Expansion) Bolts: Carbon steel to ASTM A307; nut to conform to ASTM A194; drilled-in type. Design values for shear and tension not more than 80 percent of the allowable listed loads.
 - 3. Anchor (Adhesive) Bolts: Consisting of two-part adhesive cartridge and zinc-plated Type A307 steel anchor bolt rod assembly with ASTM A194 nut.
- C. Beam Clamps:
 - 1. MSS Type 19 and 23, wide throat, with retaining clip.
 - 2. Universal Side Beam Clamp: MSS Type 20.
- D. Powder-Actuated Drive Pin Fasteners:
 - 1. Powder-Actuated Drive-Pin Fasteners: Powder actuated type, drive pin attachments with pull-out and shear capacities appropriate for supported loads and building materials where used.
- E. Mechanical-Anchor Fasteners: Insert-type attachments with pull-out and shear capacities appropriate for supported loads and building materials where used.
- F. Grout: ASTM C1107, Grade B, factory mixed and packaged, nonshrink and nonmetallic, dry, hydraulic-cement grout.
 - 1. Characteristics: Post hardening and volume adjusting; recommended for both interior and exterior applications.
 - 2. Properties: Nonstaining, noncorrosive, and non-gaseous.
 - 3. Design Mix: 5000-PSI (34.5-MPa), 28-day compressive strength.

2.5 FLASHING

- A. Steel Flashing: 26 gauge galvanized steel.
- B. Safes: 8 mil thick neoprene.

- C. Caps: Steel, 22 gauge minimum, 16 gauge at fire-resistant structures.
- D. Provide hot dipped galvanized components for items exposed to weather.

2.6 MISCELLANEOUS METAL AND MATERIALS

- A. Miscellaneous Metal: Provide miscellaneous metal items specified hereunder, including materials, fabrication, fastenings and accessories required for finished installation, where indicated on Drawings or otherwise not shown on drawings, that are necessary for completion of the project. The Contractor is responsible for their design.
 - 1. Fabricate miscellaneous units to size, shapes and profiles indicated or, if not indicated, of required dimensions to receive adjacent other work to be retained by framing. Except as otherwise shown, fabricate from structural steel shapes and plates and steel bars, of welded construction using mitered joints for field connection. Cut, drill and tap units to receive hardware and similar items.
- B. Structural Shapes: Where miscellaneous metal items are needed to be fabricated from structural steel shapes and plates, provide members constructed of steel conforming with requirements of ASTM A36 or approved equivalent.
- C. Steel Pipe: Provide seamless steel pipe conforming to requirements of ASTM A53, Type S, Grade A, or Grade B. Weight and size required as specified.
- D. Fasteners: Provide fasteners of types as required for assembly and installation of fabricated items; surface-applied fasteners are specified elsewhere.
- E. Bolts: Low carbon steel externally and internally threaded fasteners conforming with requirements of ASTM A307; include necessary nuts and plain hardened washers. For structural steel elements supporting mechanical material or equipment from building structural members or connection thereto, use fasteners conforming to ASTM A325.
- F. Miscellaneous Materials: Provide incidental accessory materials, tools, methods and equipment required for fabrication.
- G. Provide hot dipped galvanized components for items exposed to weather.
- H. Use straps, threshold rods and wire with sizes required by SMACNA to support piping.
- I. Grout: ASTM C1107, Grade B, factory mixed and packaged, nonshrink and nonmetallic, dry, hydraulic-cement grout.
 - 1. Characteristics: Post hardening and volume adjusting; recommended for both interior and exterior applications.
 - 2. Properties: Nonstaining, noncorrosive, and non gaseous.
 - 3. Design Mix: 5000-PSI (34.5-MPa), 28-day compressive strength.

PART 3 - EXECUTION

3.1 GENERAL INSTALLATION REQUIREMENTS

- A. Examination:

1. Verify building materials to have hangers and attachments affixed in accordance with hangers to be used. Provide supporting calculations.
- B. Preparation:
 1. Examine Drawings and coordinate for verification of exact locations of fire and smoke rated walls, partitions, floors and other assemblies. Indicate, by shading and labeling on Record Drawings such locations and label as "1-Hour Wall," "2-Hour Fire/Smoke Barrier," and the like. Determine proper locations for piping penetrations. Set sleeves in place in new floors, walls or roofs prior to concrete pour or grouting.
- C. Install hangers, supports, anchors and sleeves after required building structural work has been completed in areas where the work is to be installed. Coordinate with project structural engineer proper placement of inserts, anchors and other building structural attachments.

3.2 PIPE HANGERS AND SUPPORTS FOR PLUMBING PIPING AND EQUIPMENT

- A. Hangers and Supports:
 1. Comply with MSS SP-58. Pipe Hanger and Support Installation: Install hangers, supports, clamps, and attachments as required to properly support piping from building structure. For horizontally hung grooved-end piping, provide a minimum of 2 hangers per pipe section.
 2. Pipe Ring Diameters:
 - a. Uninsulated and Insulated Pipe, except where oversized pipe rings are specified: Ring inner diameter to suit pipe outer diameter.
 - b. Insulated Piping Where Oversized Pipe Rings are Specified and Vibration Isolating Sleeves: Ring inner diameter to suit outer diameter of insulation or sleeve.
 3. Oversize Pipe Rings: Provide oversize pipe rings of 2-inch and larger size.
 4. Pipe Support Brackets: Support pipe with pipe slides.
 5. Steel Backing in Walls: Provide steel backing in walls to support fixtures and piping hung from steel stud walls.
 6. Channel Support System Installation: Arrange for grouping of parallel runs of piping and support together on field-assembled channel systems.
 - a. Field assemble and install according to manufacturer's written instructions.
 7. Pipe Guides:
 - a. Install on continuous runs where pipe alignment must be maintained. Provide a minimum of two on each side of expansion joints, spaced per manufacturer's recommendations for pipe size. Fasten guides to pipe structure. Any contact with chilled water pipe should not permit heat to be transferred in sufficient quantity to cause condensation on any surface.
 - b. Install approximately 4 pipe diameters (first guide) and 14 diameters (second guide) away from each end of expansion joints. Do not use as supports. Provide in addition to other required pipe hangers and supports.
 8. Heavy-Duty Steel Trapeze Installation: Arrange for grouping of parallel runs of horizontal piping and support together on field -fabricated, heavy-duty trapezes.
 - a. Pipes of Various Sizes: Support together and space trapezes for smallest pipe size or install intermediate supports for smaller diameter pipes as specified above for individual pipe hangers.
 - b. Field fabricate from ASTM A 36/A 36M, steel shapes selected for loads being supported. Weld steel according to AWS D-1.1

9. Group parallel runs of horizontal piping to be supported together on trapeze-type hangers.
10. Where piping of various sizes is to be supported together by trapeze hangers, space hangers for smallest pipe size or install intermediate supports for smaller diameter pipe.
11. Do not support piping from other piping.
12. Fire protection piping will be supported independently of other piping.
13. Prevent electrolysis in support of copper tubing by use of hangers and supports which are copper plated.
14. Install hangers and supports complete with necessary inserts, bolts, rods, nuts, washers and other accessories.
15. Install hangers and supports to allow controlled thermal and seismic movement of piping systems, to permit freedom of movement between pipe anchor, and to facilitate the action of expansion joints, expansion loops, expansion bends and similar units.
16. Load Distribution: Install hangers and supports so that piping live and dead loads and stresses from movement will not be transmitted to connected equipment.
17. Pipe Slopes: Install hangers and supports to provide indicated pipe slopes and so maximum pipe deflections allowed by ASME B31.9, "Building Services Piping" is not exceeded.
18. Insulated Piping: (comply with the following)
 - a. Attach clamps and spacers to piping.
 - 1) Piping Operating above Ambient Air Temperature: Clamp may project through insulation.
 - 2) Piping Operating below Ambient Air Temperature: Use thermal-hanger shield insert with clamp sized to match OD of insert.
 - 3) Do not exceed pipe stress limits according to ASME B31.9.
 - b. Install MSS SP-58, Type 39 protection saddles, if insulation without a vapor barrier is indicated. Fill interior voids with insulation that matches adjoining insulation.
 - 1) Option: Thermal-hanger shield inserts may be used. Include steel weight-distribution plate for pipe NPS 4 (DN100) and larger if pipe is installed on rollers.
 - c. Install MSS SP-58, Type 40 protective shields on cold piping having a vapor barrier. Shields to span arc of 180 degrees.
 - 1) Option: Thermal-hanger shield inserts may be used. Include steel weight-distribution plate for pipe NPS 4 (DN100) and larger if pipe is installed on rollers.
 - d. Shield Dimensions for Pipe, not less than the following:
 - 1) NPS 1/4 to NPS 3-1/2 (DN8 to DN 90): 12-inches long and 0.048-inch thick.
 - 2) NPS 4 (DN100): 12-inches long and 0.06-inch thick.
 - 3) NPS 5 and NPS 6 (DN125 and DN150): 18-inches long and 0.06-inch thick.
 - 4) NPS 8 to NPS 14 (DN200 to DN350): 24-inches long and 0.075-inch thick.
 - 5) NPS 16 to NPS 24 (DN400 to DN600): 24-inches long and 0.105-inch thick.
 - e. Pipes NPS 8 (DN200) and Larger: Include wood inserts.
 - f. Insert Material: Length at least as long as protective shield.
 - g. Thermal-Hanger Shields: Install with insulation same thickness as piping insulation.
19. Equipment Clearances: Do not route equipment or piping through electrical rooms, elevator equipment rooms, MPOE rooms, or other electrical or electronic equipment spaces and enclosures and the like. Within equipment rooms, provide minimum 3-feet

lateral clearance from all sides of electric switchgear panels. Do not route piping or equipment above any electric power or lighting panel, switchgear, or similar electric device. Coordinate with Electrical and coordinate exact equipment or pipe routing to provide proper clearance with such items.

20. Pipe supports and hanger spacing (pipe supported from structure or floor-supported) to meet the requirements of References and Standards Article in Part 1 above.

B. Pipe Curb Assemblies:

1. Provide for piping and electrical conduit which penetrates the structural roof deck to service equipment above the roof level (i.e., piping, electrical power and control wiring). Meet requirements of roof warranty.
2. Provide prefabricated units for roof membrane and insulation penetrations related to equipment. Coordinate with roofing system. Set supports on the structural deck. Do not set supports on insulation or roofing. Provide level supports by prefabricated pitch built into the curb.
3. Piping above roof to be supported with freestanding roof pipe supports unless detailed otherwise. At roofing applications, the adhesion mastic is to be specifically submitted to and approved by the roofing system manufacturer/installer to maintain the integrity of all warranties.
4. At concrete floors, install a polyurethane mastic to the support block and adhere in place.

C. Vertical Piping:

1. Support with U-clamps fastened to wall to hold piping away from wall unless otherwise approved.
2. Riser clamps to be directly under fitting or welded to pipe. Provide neoprene pads for all systems except natural gas.
3. Riser to be supported at each floor penetration.
4. Provide structural steel supports at the base of pipe risers. Size supports to carry forces exerted by piping system when in operation.

D. Adjusting and Painting:

1. Adjust hangers so as to distribute loads equally on attachments. Provide grout under supports to bring piping and equipment to proper level and elevations.
2. Prime paint ferrous nongalvanized hangers, accessories, and supplementary steel which are not factory painted.

3.3 WALL AND FLOOR SLEEVES

- A. "Link-Seal" Pipe Sleeves: Install at slab on grade floor/below grade piping penetrations. Provide manufacturer's sleeve appropriate to seal type for pre-cast penetrations (except for DWV piping at slab on grade). Provide manufacturer's sleeve appropriate to seal type for pre-cast penetrations.

B. Fabricated Pipe Sleeves:

1. Provide either steel or sheet metal pipe sleeves accurately centered around pipe routes. Size such that piping and insulation, if any, will have free movement within the sleeve, including allowance for thermal expansion. Sleeve diameter to be determined by local seismic clearance requirement, and by waterproofing requirements.
2. Length: Equal to thickness of construction penetrated, except extend floor sleeves 1-inch above floor finish.

3. Provide temporary support of sleeves during placement in concrete and other work around sleeves. Provide temporary end closures to prevent concrete and other materials from entering pipe sleeves.
4. Seal each end airtight with a resilient nonhardening sealer, UL listed and fire rated per ASTM 814.

3.4 BUILDING ATTACHMENTS

- A. Install within concrete slabs or attach to structural steel or wood. Install additional building attachments where support is required for additional concentrated loads, including valves, flanges, guides, strainers, expansion joints and at changes in direction of piping.
- B. Attachment to Wood Structure: Provide MSS Type 34 for attachment to wooden beam or approved attachment for a wood structure.
- C. Install mechanical-anchor fasteners in concrete after concrete is placed and completely cured. Install fasteners according to manufacturer's written instructions.
- D. Install concrete inserts before concrete is placed; fasten insert secure to forms. Where concrete with compressive strength less than 2500 PSI is indicated, install reinforcing bars through openings at top in inserts.
- E. Install powder-actuated drive pin fasteners in concrete after concrete is placed and completely cured. Use operators that are licensed by powder-actuated tool manufacturer. Install fasteners according to powder-actuated tool manufacturer's operating manual. Test powder-actuated insert attachments with a minimum load of 100 pounds.
- F. Bolting: Provide bored, drilled or reamed holes for bolting to miscellaneous structural metals, frames or for mounts or supports. Flame cut, punched or hand sawn holes will not be accepted.
- G. Anchor Bolts:
 1. Install anchor bolts for mechanical equipment and piping as required. Tightly fit and clamp base-supported equipment anchor bolts at equipment support points. Provide locknuts where equipment and piping are hung.
 2. Anchor Bolts (Cast-In-Place): Embed anchor bolts in new cast-in-place concrete to anchor equipment. Install a pipe sleeve around the anchor bolt for adjustment of the top 1/3 of the bolt embedment; sizes and patterns to suit the installation conditions of the equipment to be anchored.
- H. Pipe Anchors: Provide anchors to fasten piping which is subject to expansion and contraction, and adjacent to equipment to prevent loading high forces onto the equipment.
- I. Escutcheon Plates: Install around horizontal and vertical piping at visible penetrations through walls, partitions, floors, or ceilings, including penetrations through closets, through below ceiling corridor wall, and through equipment room walls and floors.
- J. Installation of metallic or plastic piping penetrations through non fire-rated walls and partitions and through smoke-rated walls and partitions:
 1. Install fabricated pipe sleeve.
 2. After installation of sleeve and piping, tightly pack entire annular void between piping or piping insulation and sleeve identification with specified material.

3. Seal each end airtight with a resilient nonhardening UL listed fire resistant ASTM 814 sealant.
- K. Piping Penetrations Through Fire-rated (1 to 3 hour) Assemblies:
1. Select and install pre-engineered pipe penetration system in accordance with the UL listing and manufacturer's recommendation.
 2. Provide proper sizing when providing sleeves or core-drilled holes to accommodate the penetration. Firestop voids between sleeve or core-drilled hole and pipe passing through to meet the requirements of ASTM E814. Use HOLDRITE HydroFlame or approved equivalent.
- L. Install hangers and supports complete with necessary inserts, bolts, rods, nuts, washers and other accessories.

3.5 FLASHING

- A. Flash and counterflash where piping passes through weather or waterproofed walls, floors and roofs.
- B. Flash vent soil pipes with flashings per Division 01, General Requirements.
- C. Flash floor drains over finished areas and roof drains, 10-inches clear on sides, minimum 36-inches x 36-inches sheet size. See Division 01, General Requirements. Fasten flashing to drain with clamping device.
- D. Install built up fixtures (mop sinks, shower stalls, shower floors) with water sealing systems/membranes to meet Code and as prescribed by Division 01, General Requirements and Section 22 00 00, Plumbing Basic Requirements. Meet all Code testing requirements. Provide drainage devices with appropriate flanges, clamps, etc. to meet these installation requirements and ensure a water-tight installation.

3.6 MISCELLANEOUS METAL AND MATERIALS

- A. Coordinate and furnish anchorages, setting drawings, diagrams, templates, instructions and directions for installation of anchorages, such as concrete inserts, sleeves, anchor bolts and miscellaneous items having integral anchors, which are to be embedded in concrete or masonry construction. Coordinate delivery of such items to project site.
- B. Fastening to In-Place Construction: Provide anchorage devices and fasteners where necessary for securing miscellaneous metal fabrications to in-place construction; including, threaded fasteners for concrete and masonry inserts, toggle bolts, through-bolts, lag bolts, wood screws and other connectors as required. Avoid cutting concrete reinforcing when drilling for inserts. Reference structural drawings and reinforcing shop drawings and determine locations of stirrups prior to drilling into concrete.
- C. Cutting, Fitting and Placement: Perform cutting, drilling and fitting required for installation of miscellaneous metal fabrications. Set work accurately in location, alignment and elevation, plumb, level, true and free of rack, measured from established lines and levels. Provide temporary bracing or anchors in formwork for items which are to be built into concrete masonry or similar construction.

- D. Field Welding: Comply with AWS Code for procedures of manual shielded metal-arc welding, appearance and quality of welds made, and methods used in correcting welding work.
- E. Setting Loose Plates: Clean concrete and masonry bearing surfaces of any bond reducing materials, and roughen to improve bond to surfaces. Clean bottom surface of bearing plates.
1. Set loose leveling and bearing plates on wedges or other adjustable devices. After the bearing members have been positioned and plumbed, tighten the anchor bolts. Do not remove wedges or shims, but if protruding, cut-off flush with edge of the bearing plate before packing with grout. Use metallic non-shrink grout in concealed locations where not exposed to moisture; use non-metallic non-shrink grout in exposed locations, unless otherwise indicated.
 2. Pack grout solidly between bearing surfaces and plates to ensure that no voids remain.
- F. Fabrication:
1. General: Verify dimensions prior to fabrication. Form metal items to accurate sizes and configurations as indicated on Drawings and otherwise required for proper installation; make with lines straight and angles sharp, clean and true; drill, countersink, tap, and otherwise prepare items for connections with work of other trades, as required. Fabricate to detail of structural shapes, plates and bars; weld joints where practicable; provide bolts and other connection devices required. Include anchorages; clip angles, sleeves, anchor plates and similar devices. Hot dip galvanize after fabrication items installed in exterior locations. Set accurately in position as required and anchor securely to building construction. Construct items with joints formed for strength and rigidity, accurately machining for proper fit; where exposed to weather, form to exclude water.
 2. Finishes:
 - a. Ferrous Metal: After fabrication, but before erection, clean surfaces by mechanical or chemical methods to remove rust, scale, oil, corrosion, or other substances detrimental to bonding of subsequently applied protective coatings. For metal items exposed to weather or moisture, galvanize in manner to obtain G90 zinc coating in accordance with ASTM A123. Provide other non-galvanized ferrous metal with 1 coat of approved rust-resisting paint primer, in manner to obtain not less than 1.0 mil dry film thickness. Touch-up damaged areas with primer of same material before installation. Apply zinc coatings and paint primers uniformly and smoothly; leave ready for finish painting as specified elsewhere.
 - b. Metal in contact with Concrete, Masonry and Other Dissimilar Materials:
 - 1) Where metal items are to be erected in contact with dissimilar materials, provide contact surfaces with coating of an approved zinc-chromate primer in manner to obtain not less than 1.0 mil dry film thickness, in addition to other coatings specified in these specifications.
 - c. For Galvanized Surfaces: Clean field welds, bolted connections, and abraded areas and apply galvanizing repair paint to comply with ASTM A780.
- G. Metal Fabrication:
1. Cut, drill, and fit miscellaneous metal fabrications for heavy-duty steel trapezes and equipment supports.
 2. Fit exposed connections together to form hairline joints. Field-weld connections that cannot be shop-welded because of shipping size limitations.

3. Field Welding: Comply with AWS D1.1 procedures for shielded metal arc welding, appearance and quality of weld and methods used in correcting welding work, and with the following:
 - a. Use materials and methods that minimize distortion and develop strength and corrosion resistance of base metals.
 - b. Obtain fusion without undercut or overlap.
 - c. Remove welding flux immediately.
 - d. Finish welds at exposed connections so no roughness shows after finishing and contours of welded surfaces match adjacent contours.
4. Provide hot dipped galvanized components for items exposed to weather.

END OF SECTION

SECTION 22 0553 - IDENTIFICATION FOR PLUMBING PIPING AND EQUIPMENT

PART 1 - GENERAL

1.1 SUMMARY

- A. Work Included:
 - 1. Plastic Nameplates
 - 2. Tags
 - 3. Plastic Pipe Markers

1.2 RELATED SECTIONS

- A. Contents of Division 22, Plumbing and Division 01, General Requirements apply to this Section.

1.3 REFERENCES AND STANDARDS

- A. References and Standards as required by Section 22 00 00, Plumbing Basic Requirements and Division 01, General Requirements.

1.4 SUBMITTALS

- A. Submittals as required by Section 22 00 00, Plumbing Basic Requirements and Division 01, General Requirements.
- B. In addition, submit Valve Schedule for each piping system, in tabular format using Microsoft Word or Excel software. Tabulate valve number, piping system, system abbreviation (as shown on tag), location of valve (room or space), and variations for identification (if any). Mark valves which are intended for emergency shutoff and similar special uses by special "flags" in margin of schedule. In addition to mounted copies, furnish extra copies for maintenance manuals. Provide schedules organized as follows:
 - 1. Equipment Type:
 - a. Identification:
 - b. Background:
 - 1) Size:
 - 2) Color:
 - c. Lettering:
 - 1) Size:
 - 2) Color:

1.5 QUALITY ASSURANCE

- A. Quality assurance as required by Section 22 00 00, Plumbing Basic Requirements and Division 01, General Requirements.
- B. In addition, meet the following:
 - 1. Manufacturer's Qualifications: Firms regularly engaged in manufacture of identification devices of types and sizes required.

2. Codes and Standards: Comply with ANSI A13.1 for lettering size, length of color field, colors, and viewing angles of identification devices unless otherwise indicated.

1.6 WARRANTY

- A. Warranty of materials and workmanship as required by Section 22 00 00, Plumbing Basic Requirements and Division 01, General Requirements.

PART 2 - PRODUCTS

2.1 MANUFACTURERS

- A. General: Manufacturer's standard products of categories and types required for each application as referenced in other Division 22, Plumbing Sections. Where more than a single type is specified for application, provide single selection for each product category.
- B. Plastic Nameplates:
 1. Brady Corporation
 2. Or approved equivalent.
- C. Tags:
 1. Brady Corporation
 2. Brimer
 3. Champion America Inc.
 4. Craftmark
 5. Seton Identification Products
 6. Or approved equivalent.
- D. Plastic Pipe Markers:
 1. Brady Corporation
 2. Brimer
 3. Champion America Inc.
 4. Craftmark
 5. Seton Identification Products
 6. Or approved equivalent.

2.2 PLASTIC NAMEPLATES

- A. Description: Engraving stock melamine plastic laminate 1/8-inch thick, engraved with engraver's standard letter style of the sizes and wording indicated.
 1. Letter Color: White.
 2. Letter Height: 1/2 inch.
 3. Background Color: Black.
 4. Fasteners: Self-tapping stainless steel screws, except contact-type permanent adhesive where screws cannot or should not penetrate the substrate.
 5. Access Panel Markers: Manufacturer's standard 1/16-inch thick engraved plastic laminate access panel markers, with abbreviations and numbers corresponding to concealed valve or devices/equipment. Include center hole to allow attachment.
 6. Signage for hot water outlets on 140 degree F hot water systems not protected by ASSE 1070 mixing valves; hose bibbs, janitor sinks, and fixtures used by trained personnel.

- a. Manufacturer's standard 1/8-inch thick engraved plastic laminate signage 4 by 4-inches.
- b. Letter Color: Red.
- c. Letter Height: 1/2 inch.
- d. Background Color: White.
- e. Fasteners: Self-tapping stainless steel screws, except contact-type permanent adhesive where screws cannot or should not penetrate the substrate.

2.3 TAGS

- A. Plastic Tags: Laminated three-layer plastic with engraved black letters on light contrasting background color. Tag size minimum 1-1/2-inch diameter.
- B. Metal Tags: Polished Brass with stamped letters; tag size minimum 1-1/2-inch diameter with smooth edges.
- C. Valve designations to be coordinated with existing valve identifications to ensure no repetitive designations are utilized.
- D. Chart/Schedules: Valve Schedule Frames. For each page of a valve schedule, provide glazed display frame with removable mounting as appropriate for wall construction upon which frame is to be mounted. Provide frames of finished hardwood or extruded aluminum, with SSB-grade sheet glass.
- E. Valve Tag Fasteners: Solid brass chain (wire link or beaded type), or solid brass S-hooks.
- F. Warning Tags: Preprinted or partially preprinted, accident-prevention tags; of plasticized card stock with matte finish suitable for writing.
 1. Size: Approximately 4 by 7-inches.
 2. Fasteners: Brass grommet and wire.
 3. Nomenclature: Large-size primary caption such as DANGER, CAUTION, or DO NOT OPERATE.
 4. Color: Yellow background with black lettering.

2.4 PLASTIC PIPE MARKERS

- A. Color: Conform to ASME A13.1 and ANSI Z535.1.
- B. Plastic Pipe Markers (for external diameters of 6-inches and larger including insulation): Factory fabricated, flexible, semi-rigid plastic, preformed to fit around pipe or pipe covering; minimum information indicating flow direction arrow and identification of fluid being conveyed.
- C. Plastic Tape Pipe Markers (for external diameters less than 6-inches including insulation): Flexible, vinyl film tape with pressure sensitive adhesive backing and printed markings. Minimum information indicating flow direction arrow and identification of fluid being conveyed.

PART 3 - EXECUTION

3.1 GENERAL INSTALLATION REQUIREMENTS

- A. Lettering and Graphics:
 - 1. General: Coordinate names, abbreviations and other designations used in plumbing identification work with corresponding designations shown, specified or scheduled. Provide numbers, lettering and wording as indicated or, if not otherwise indicated, as recommended by manufacturers or as required for proper identification and operation/maintenance of mechanical systems and equipment.
 - 2. Multiple Systems: Where multiple systems of same generic name are shown and specified, provide identification which indicates individual system number as well as service (as examples: Chiller No. 3, Air Handling Unit No. 42, Standpipe F12, and the like).
- B. Preparation: Degrease and clean surfaces to receive adhesive for identification materials.
- C. Coordination: Where identification is to be applied to surfaces which require insulation, painting or other covering or finish, including valve tags in finished mechanical spaces, install identification after completion of covering and painting. Install identification prior to installation of acoustical ceilings and similar removable concealment.
- D. Install valve schedule at each mechanical room.
- E. Access Doors: Provide markers on each access door and housings, indicating purpose of access (to what equipment) and other maintenance and operating instructions.

3.2 PLASTIC NAMEPLATES

- A. Identify pumps, heat transfer equipment, tanks, and water treatment devices with plastic nameplates riveted to equipment body.
- B. Identify control panels and major control components outside panels with plastic nameplates riveted to equipment body.
- C. Install plastic nameplates with corrosive-resistant mechanical fasteners.

3.3 TAGS

- A. Small devices, such as in-line pumps, may be identified with tags. Use metal tags on piping 3/4-inch diameter and smaller.
- B. Identify valves in main and branch piping with metal tags. Indicate valve function and the normally open or closed positions on the valve tag.
- C. Coordinate with the facility maintenance personnel to ensure consistency with the existing tagging system.
- D. Tag balancing valves with balanced GPM or CFM indicated after balancing is completed and accepted.

- E. Install tags with corrosion resistant chain.

3.4 PLASTIC PIPE MARKERS

- A. Install plastic pipe markers in accordance with manufacturer's instructions.
- B. Install plastic tape pipe markers complete around pipe in accordance with manufacturer's instructions.
- C. For exterior underground piping installations, install underground plastic pipe markers with tracer wire 6 to 8-inches below finished grade directly above buried pipe.
- D. Identify piping, concealed or exposed, with plastic tape pipe markers. Identify service, flow direction, and pressure. Install in clear view and align with axis of piping. Locate identification not to exceed 20-feet (reduced to 10-feet in congested areas and mechanical equipment rooms) on straight runs including risers and drops, adjacent to each valve and tee, at each side of penetration of structure or enclosure, and at each obstruction. Locate near branches, valves, control devices, equipment connections, access doors, floor/wall penetrations.

END OF SECTION

SECTION 22 0593 - TESTING, ADJUSTING, AND BALANCING FOR PLUMBING

PART 1 - GENERAL

1.1 SUMMARY

A. Work Included:

1. Balancing water flow within distribution systems of all Division 22, Plumbing Sections, including sub-mains, branches, and terminals, to indicated quantities according to specified tolerances.
2. Adjusting plumbing systems to provide indicated quantities.
3. Verifying that automatic control devices are functioning properly.
4. Reporting results of the activities and procedures specified in this Section.

1.2 RELATED SECTIONS

- A. Contents of Division 22, Plumbing and Division 01, General Requirements apply to this Section.

1.3 REFERENCES AND STANDARDS

- A. References and Standards as required by Section 22 00 00, Plumbing Basic Requirements and Division 01, General Requirements.

1.4 SUBMITTALS

- A. Submittals as required by Section 22 00 00, Plumbing Basic Requirements and Division 01, General Requirements.

1.5 QUALITY ASSURANCE

- A. Quality assurance as required by Section 22 00 00, Plumbing Basic Requirements and Division 01, General Requirements.
- B. In addition, meet the following:
1. Acceptable Balance Firm:
 - a. General:
 - 1) Procure services of independent Testing, Adjusting, and Balancing (TAB) agency to balance, adjust and test water circulating. Minimum Experience: 5 years.
 - b. Industry Standards: Testing and Balancing will conform to NEBB, American Society of Heating, Refrigerating, and Air Conditioning Engineers (ASHRAE), and American National Standards Institute (ANSI) as follows:
 - 1) NEBB: Comply with Procedural Standards for Testing, Adjusting Balancing of Environmental Systems.
 - 2) ASHRAE: Comply with recommendations pertaining to measurements, instruments, and TAB.
 - c. Test Observation: If requested, conduct tests in the presence of the Architect or the Architect's representative.

2. Provide proof of testing agency having successfully completed at least five projects of similar size and scope.
3. Code Compliance: Perform tests in the presence of the Authority Having Jurisdiction (AHJ) where required by the Authority Having Jurisdiction (AHJ).
4. Owner Witness: Perform tests in the presence of the Owners representative.
5. Engineer Witness: The engineer or engineer's representative reserves the right to observe tests or selected tests to assure compliance with the specifications.
6. Simultaneous Testing: Test observations by the Authority Having Jurisdiction (AHJ), the Owner's Authorized Representative and the engineer's representative need not occur simultaneously.
7. Do not perform TAB work until plumbing equipment has been completely installed and is operating continuously as required.
8. Conduct TAB with clean filters in place. Clean strainers prior to performing TAB.
9. Agent Qualifications: Engage a TAB Agent certified by AABC or NEBB.
10. TAB Conference: Meet with the Owner's and the Architect's representatives on approval of the TAB strategies and procedures plan to develop a mutual understanding of the details. Ensure the participation of TAB team members, equipment manufacturers' authorized service representatives, controls Installer, and other support personnel. Provide 7 days advance notice of scheduled meeting time and location.
 - a. Agenda Items: Include at least the following:
 - 1) Submittal distribution requirements.
 - 2) TAB plan.
 - 3) Work schedule and Project site access requirements.
 - 4) Coordination and cooperation of trades and subcontractors.
 - 5) Coordination of documentation and communication flow.
11. Certification of TAB Reports: Certify the TAB field data reports. This certification includes the following:
 - a. Review field data reports to validate accuracy of data and to prepare certified TAB reports.
 - b. Certify that the TAB team complied with the approved TAB plan and the procedures specified and referenced in this Specification.
12. TAB Reports: Use standard forms from AABC's "National Standards for Testing, Adjusting, and Balancing."
13. TAB Reports: Use standard forms from NEBB's "Procedural Standards for Testing, Adjusting, and Balancing of Environmental Systems."
14. Instrumentation Type, Quantity, and Accuracy: As described in AABC national standards.
15. Instrumentation Type, Quantity, and Accuracy: As described in NEBB's "Procedural Standards for Testing, Adjusting, and Balancing of Environmental Systems," Section II, "Required Instrumentation for NEBB Certification."
16. Instrumentation Calibration: Calibrate instruments at least every 6 months or more frequently if required by the instrument manufacturer.

1.6 WARRANTY

- A. Warranty of materials and workmanship as required by Section 22 00 00, Plumbing Basic Requirements and Division 01, General Requirements.

1.7 DEFINITIONS

- A. Adjust: To regulate fluid flow rate at the equipment.
- B. Balance: To proportion flows within the distribution system, including sub mains, branches, and terminals, according to design quantities.
- C. Procedure: An approach to and execution of a sequence of work operations to yield repeatable results.
- D. Report Forms: Test data sheets for recording test data in logical order.
- E. Static Head: The pressure due to the weight of the fluid above the point of measurement. In a closed system, static head is equal on both sides of the pump.
- F. Suction Head: The height of fluid surface above the centerline of the pump on the suction side.
- G. System Effect: A phenomenon that can create undesired or unpredicted conditions that cause reduced capacities in all or part of a system.
- H. System Effect Factors: Allowances used to calculate a reduction of the performance ratings of a fan when installed under conditions different from those presented when the fan was performance tested.
- I. TAB: Testing, Adjusting, and Balancing.
- J. Terminal: A point where the controlled medium, such as fluid or energy, enters or leaves the distribution system.
- K. Test: A procedure to determine quantitative performance of a system or equipment.
- L. Testing, Adjusting, and Balancing (TAB) Agent: The entity responsible for performing and reporting the TAB procedures.
- M. AABC: Associated Air Balance Council.
- N. AMCA: Air Movement and Control Association.
- O. CTI: Cooling Tower Institute.
- P. NEBB: National Environmental Balancing Bureau.
- Q. SMACNA: Sheet Metal and Air Conditioning Contractors' National Association.

1.8 COORDINATION

- A. Coordinate the efforts of factory-authorized service representatives for systems and equipment, controls installers, and other mechanics to operate systems and equipment to support and assist TAB activities.

- B. Notice: Provide 7 days advance notice for each test. Include scheduled test dates and times.
- C. Perform TAB after leakage and pressure tests on piping distribution systems have been satisfactorily completed.

PART 2 - PRODUCTS - NOT USED

PART 3 - EXECUTION

3.1 PROJECT CONDITIONS

- A. Full Owner Occupancy: The Owner will occupy the site and existing building during the entire TAB period. Cooperate with the Owner during TAB operations to minimize conflicts with the Owner's operations.
- B. Partial Owner Occupancy: The Owner may occupy completed areas of the building before Substantial Completion. Cooperate with the Owner during TAB operations to minimize conflicts with the Owner's operations.
- C. Non-Owner Occupancy: Complete balancing of building systems prior to Substantial Completion and owner occupancy.

3.2 EXAMINATION

- A. Examine Contract Documents to become familiar with project requirements and existing building record documents (if available) to discover conditions in systems' designs that may preclude proper TAB of systems and equipment.
 - 1. Contract Documents are defined in the General and Supplementary Conditions of the Contract.
 - 2. Verify that balancing devices, such as test ports, gauge cocks, thermometer wells, flow-control devices, balancing valves and fittings are required by the Contract Documents. Verify that quantities and locations of these balancing devices are accessible and appropriate for effective balancing and for efficient system and equipment operation.
- B. Examine approved submittal data of Plumbing systems and equipment.
- C. Examine equipment performance data including pump curves. Relate performance data to project conditions and requirements, including system effects that can create undesired or unpredicted conditions that cause reduced capacities in all or part of a system.
- D. Examine system and equipment installations to verify that they are complete and that testing, cleaning, adjusting, and commissioning specified in individual Specification Sections have been performed.
- E. Examine system and equipment installations to verify that indicated balancing devices, such as test ports, gauge cocks, thermometer wells, flow-control devices, balancing valves and fittings are properly installed, and their locations are accessible and appropriate for effective balancing and for efficient system and equipment operation.

- F. Examine systems for functional deficiencies that cannot be corrected by adjusting and balancing.
- G. Examine open-piping-system pumps to ensure absence of entrained air in the suction piping.
- H. Examine equipment for installation and for properly operating safety interlocks and controls.
- I. Examine automatic temperature system components to verify the following:
 - 1. Valves, and other controlled devices operate by the intended controller.
 - 2. Valves are in the position indicated by the controller.
 - 3. Integrity of valves for free and full operation and for tightness of fully closed and fully open positions.
 - 4. Automatic modulating and shutoff valves, including 2-way valves and 3-way mixing and diverting valves, are properly connected.
 - 5. Sensors are located to sense only the intended conditions.
 - 6. Sequence of operation for control modes is according to the Contract Documents.
 - 7. Controller set points are set at design values. Observe and record system reactions to changes in conditions. Record default set points if different from design values.
- J. Report deficiencies discovered before and during performance of TAB procedures.
- K. Beginning of work means acceptance of existing conditions.

3.3 PREPARATION

- A. Prepare a TAB plan that includes strategies and step-by-step procedures.
- B. Complete system readiness checks and prepare system readiness reports. Verify the following:
 - 1. Permanent electrical power wiring is complete.
 - 2. Systems are filled, clean, and free of air.
 - 3. Automatic temperature-control systems are operational.
 - 4. Isolating and balancing valves are open and control valves are operational.
- C. Hold a pre-balancing meeting at least one week prior to starting TAB work.
 - 1. Attendance is required by installers whose work will be tested, adjusted, or balanced.
- D. Provide instruments required for TAB operations. Make instruments available to Architect to facilitate spot checks during testing.

3.4 GENERAL TESTING AND BALANCING PROCEDURES

- A. Perform TAB procedures on each system according to the procedures contained in AABC national standards or NEBB's "Procedural Standards for Testing, Adjusting, and Balancing of Environmental Systems" and this Section.
- B. Cut insulation for pipes, and equipment cabinets for installation of test probes to the minimum extent necessary to allow adequate performance of procedures. After testing and balancing, close probe holes and patch insulation with new materials identical to those removed. Restore vapor barrier and finish according to the insulation Specifications for this Project.

- C. Mark equipment settings with paint or other suitable, permanent identification material, including control positions, valve indicators and similar controls and devices, to show final settings.

3.5 ADJUSTMENT TOLERANCES

- A. Piping Systems: Adjust to within plus or minus 10 percent of design.

3.6 RECORDING AND ADJUSTING

- A. Field Logs: Maintain written logs including:
 1. Running log of events and issues.
 2. Discrepancies, deficient or uncompleted work by others.
 3. Contract interpretation requests.
 4. Lists of completed tests.
- B. Ensure recorded data represents actual measured or observed conditions.
- C. Permanently mark settings of valves and other adjustment devices allowing settings to be restored. Set and lock memory stops.
- D. Mark on drawings locations where other critical measurements were taken and cross reference location in final report.

3.7 FUNDAMENTAL PROCEDURES FOR PIPING SYSTEMS

- A. Prepare test reports with pertinent design data and number in sequence starting at pump to end of system. Check the sum of branch-circuit flows against approved pump flow rate. Correct variations that exceed plus or minus 10 percent.
- B. Prepare schematic diagrams of systems' "as-built" piping layouts.
- C. Prepare systems for TAB according to the following, in addition to the general preparation procedures specified above:
 1. Open manual valves for maximum flow.
 2. Check expansion tank liquid level, or air charge if bladder type.
 3. Check makeup-water-station pressure gauge for adequate pressure.
 4. Check flow-control valves for specified sequence of operation and set at design flow.
 5. Check pump-motor load. If motor is overloaded, throttle main flow-balancing device so motor nameplate rating is not exceeded.

3.8 FINAL REPORT

- A. General: Computer printout in letter-quality font, on standard bond paper, in 3-ring binder, tabulated and divided into Sections by tested and balanced systems.
- B. Include a certification sheet in front of binder signed and sealed by the certified TAB engineer.
 1. Include a list of the instruments used for procedures, along with proof of calibration.
- C. Final Report Contents: In addition to the certified field report data, include the following:

1. Pump curves.
 2. Field test reports prepared by system and equipment installers.
 3. Other information relative to equipment performance, but do not include approved Shop Drawings and Product Data.
- D. General Report Data: In addition to the form titles and entries, include the following data in the final report, as applicable:
1. Title page.
 2. Name and address of TAB Agent.
 3. Project name.
 4. Project location.
 5. Architect's name and address.
 6. Engineer's name and address.
 7. Contractor's name and address.
 8. Report date.
 9. Signature of TAB Agent who certifies the report.
 10. Summary of contents, including the following:
 - a. Design versus final performance.
 - b. Notable characteristics of systems.
 - c. Description of system operation sequence if it varies from the Contract Documents.
 11. Nomenclature sheets for each item of equipment.
 12. Notes to explain why certain final data in the body of reports vary from design values.
- E. Pump Test Reports: For pumps, include the following data. Calculate impeller size by plotting the shutoff head on pump curves.
1. Unit Data: Include the following:
 - a. Unit identification.
 - b. Location.
 - c. Service.
 - d. Make and size.
 - e. Model and serial numbers.
 - f. Water flow rate in gpm (L/s).
 - g. Water pressure differential in feet of head or PSIG (kPa).
 - h. Required net positive suction head in feet of head or PSIG (kPa).
 - i. Pump rpm.
 - j. Impeller diameter in inches.
 - k. Motor make and frame size.
 - l. Motor horsepower and rpm.
 - m. Voltage at each connection.

END OF SECTION

SECTION 22 0700 - PLUMBING INSULATION

PART 1 - GENERAL

1.1 SUMMARY

- A. Work Included:
 - 1. Type 1, Glass Wool Pipe Insulation
 - 2. Type 2, Flexible Elastomeric Insulation
 - 3. Type 5, Glass Wool Equipment Insulation
 - 4. Type 7, ADA Accessible Lavatory/Sink Insulation Kit
 - 5. Accessories
 - 6. Pipe Fitting Insulation Covers

1.2 RELATED SECTIONS

- A. Contents of Division 22, Plumbing and Division 01, General Requirements apply to this Section.

1.3 REFERENCES AND STANDARDS

- A. References and Standards as required by Section 22 00 00, Plumbing Basic Requirements and Division 01, General Requirements.
- B. In addition, meet the following:
 - 1. Piping insulation products to contain less than 0.1 percent by weight PBDE in all insulating materials.

1.4 SUBMITTALS

- A. Submittals as required by Section 22 00 00, Plumbing Basic Requirements and Division 01, General Requirements.
- B. In addition, provide:
 - 1. Installer qualifications.
 - 2. Product Data: Identify thermal conductivity, thickness, and jackets (both factory and field applied, if any), for each type of product indicated.
 - 3. Material Test Reports: From a qualified testing agency acceptable to authorities having jurisdiction indicating, interpreting, and certifying test results for compliance of insulation materials, sealers, attachments, cements, and jackets with requirements indicated. Include dates of tests.
 - 4. Installer Certificates: Signed by the Contractor certifying that installers comply with requirements.
 - 5. Submit manufacturer's installation instructions.

1.5 QUALITY ASSURANCE

- A. Quality assurance as required by Section 22 00 00, Plumbing Basic Requirements and Division 01, General Requirements apply to this Section.
- B. In addition, meet the following:

1. Formaldehyde Free: Should be third-party certified with UL Environment Validation.
2. Recycled Content: A minimum of 40 percent post-consumer recycled glass content certified and UL validated.
3. Low Emitting Materials: For all thermal and acoustical applications of Glass Mineral Wool Insulation products, provide materials complying with the testing and products requirements of UL GREENGUARD Gold Certification.
4. Installer to have minimum 5 years' experience in the business of installing insulation.

1.6 WARRANTY

- A. Warranty of materials and workmanship as required by Section 22 00 00, Plumbing Basic Requirements and Division 01, General Requirements.

1.7 FIRE HAZARD CLASSIFICATION

- A. Maximum fire hazard classification of the composite insulation construction as installed to be not more than a Flame Spread Index (FSI) of 25 and Smoke Developed Index (SDI) of 50 as tested by current edition of ASTM E84 (NFPA 255) method.
- B. Test pipe insulation in accordance with requirements of current edition of UL "Pipe and Equipment Coverings".

PART 2 - PRODUCTS

2.1 MANUFACTURERS

- A. Type 1, Glass Wool Pipe Insulation:
 1. Owens-Corning
 2. Johns Manville
 3. Or approved equivalent.
- B. Type 2, Flexible Elastomeric Insulation:
 1. Insulation:
 - a. Armacell LLC Armaflex
 - b. K-Flex
 - c. Or approved equivalent.
 2. Glue:
 - a. Armacell LLC Armaflex Low VOC Adhesive
 - b. K-Flex
 - c. Or approved equivalent.
 3. Paint:
 - a. Armacell LLC Armaflex
 - b. K-Flex
 - c. Or approved equivalent.
- C. Type 5, Glass Wool Equipment Insulation:
 1. Knauf
 2. Owens-Corning
 3. Johns Manville
 4. Or approved equivalent.

D. Type 7, ADA Accessible Lavatory/Sink Insulation Kit:

1. IPS/Truebro
2. McGuire/Pro-Wrap
3. Plumberex/Pro-Extreme
4. Brocar Trap Wrap
5. Or approved equivalent.

E. Accessories:

1. ITW Insulation Systems
2. Or approved equivalent.

F. Pipe Fitting Insulation Covers:

1. Zeston Johns Manville
2. ITW Insulation Systems
3. Or approved equivalent.

2.2 TYPE 1, GLASS WOOL PIPE INSULATION

A. Glass Fiber: ASTM C547 Type I and IV; rigid molded, noncombustible.

1. Thermal Conductivity Value: 0.27 BTU*in/(hr*sf°F) at 75 degrees F.
2. Maximum Service Temperature: 850 degrees F to 1000 degrees F.
3. Vapor Retarder Jacket: White Kraft paper reinforced with glass fiber and bonded to aluminum foil, with self-sealing longitudinal laps and butt strips or vapor barrier mastic.

2.3 TYPE 2, FLEXIBLE ELASTOMERIC INSULATION

A. Elastomeric Foam: ASTM C534; flexible, cellular elastomeric, molded or sheet.

1. Thermal Conductivity Value: 0.25 BTU*in/(hr*sf°F) at 75 degrees F.
2. Maximum Service Temperature of 220 degrees F.
3. Maximum Flame Spread: 25.
4. Maximum Smoke Developed: 50 (3/4-inch thick and below).
5. Connection: Waterproof vapor retarder adhesive as needed.
6. UV Protection: UV outdoor protective coating per manufacturer's requirements.

B. Glue: Contact adhesive specifically manufactured for cementing flexible elastomeric foam.

C. Paint: Nonhardening high elasticity type, specifically manufactured as a protective covering of flexible elastomeric foam insulation for prevention of degradation due to exposure to sunlight and weather.

2.4 TYPE 5, GLASS WOOL EQUIPMENT INSULATION

A. Flexible Glass Wool Blanket: ASTM C612; flexible.

1. Thermal Conductivity Value: 0.24 BTU*in/(hr*sf°F) at 75 degrees F.
2. Maximum Service Temperature: 450 degrees F.

2.5 TYPE 7, ADA ACCESSIBLE LAVATORY/SINK INSULATION KIT

- A. P-traps, trap arms, tail pieces, hot water and cold water insulating guards meeting ASTM C1822. Molded closed cell insulation with vinyl cover and nylon fasteners, paintable. Thermal conductivity; $K = 1.17$ (BTU*in/(hr*sf*F) at 75 degrees F mean temperature. Provide accessories as required for complete installation covering all exposed waste piping, water piping, stops and supplies. Color white.

2.6 ACCESSORIES

- A. Equipment Insulation Compounds: Provide adhesives, cement, sealers, mastics and protective finishes as recommended by insulation manufacturer for applications indicated.
- B. Provide staples, bands, wire, wire netting, tape corner angles, anchors, stud pins and metal covers as recommended by insulation manufacturer for applications indicated. Accessories, i.e., adhesives, mastics, cements and tape to have same flame and smoke component ratings as insulation materials with which they are used. Shipping cartons to bear a label indicating that flame and smoke ratings do not exceed those listed above. Provide permanent treatment of jackets or facings to impart flame and smoke safety. Provide non-water soluble treatments. Provide UV protection recommended by manufacturer for outdoor installation.

2.7 PIPE FITTING INSULATION COVERS

- A. PVC Plastic Fitting Covers: Schuller Zeston 2000, Knauf Proto Fitting or approved equivalent. One-piece molded type fitting covers and jacketing material, gloss white. Connections: Tacks; pressure sensitive color matching vinyl tape.

PART 3 - EXECUTION

3.1 GENERAL INSTALLATION INFORMATION

- A. Verification of Conditions:
 - 1. Do not apply insulation until pressure testing and inspection of piping has been completed.
 - 2. Examine areas and conditions under which insulation will be installed. Do not proceed with work until unsatisfactory conditions have been corrected.
- B. Preparation: Clean and dry surfaces to be insulated.
- C. Installation:
 - 1. Insulation: Continuous through walls, floors and partitions except where noted otherwise.
 - 2. Piping and Equipment:
 - a. Install insulation over clean, dry surfaces with adjoining sections firmly butted together and covering surfaces. Fill voids and holes. Seal raw edges. Install insulation in a manner such that insulation may be split, removed, and reinstalled with vapor barrier tape on strainer caps and unions. Do not install insulation until piping has been leak tested and has passed such tests. Do not insulate manholes, equipment manufacturer's nameplates, handholes, and ASME stamps. Provide beveled edge at such insulation interruptions. Repair voids or tears.

- D. Provide accessories as required. See Part 2 Article "Accessories" above.
- E. Protection and Replacement: Protect installed insulation during construction. Replace damaged insulation which cannot be repaired satisfactorily, including units with vapor barrier damage and moisture saturated units.
- F. Labeling and Marking: Provide labels, arrows and color coding on piping. Attach labels and flow direction arrows to jacketing per Section 22 05 53, Identification for Plumbing Piping and Equipment.
- G. Insulation Shields: Provide hangers and shields (18 gauge minimum) outside of insulation for cold piping (<60 degrees F). Hot water piping hangers may penetrate insulation to contact pipe directly. Provide 18-inch long, noncompressible insulation section at insulation shields for lines 1-1/2-inches and larger (hot and cold piping).
- H. Piping Surfaces to be Insulated:

Item to be Insulated	System Insulation Type	Pipe Size	Insulation Thickness
Hot Water Piping Above Grade (105F to 140F)	1	Runouts up to 1-1/2-inch (uncirculated branches)	1-inch
		Mains =<1-1/4-inch	1-inch
		Mains >1-1/4-inch	1-1/2-inch
Hot Water Circulation Piping Above Grade (105F to 140F)	1	Runouts up to 1-1/2-inch	1-inch
		Mains =<1-1/4-inch	1-inch
		Mains >1-1/4-inch	1-1/2-inch
Hot Water Piping Above Grade (141F to 200F)	1	Runouts up to 1-1/2-inch	1-inch
		Mains =<1-1/4-inch	1-1/2-inch
		Mains >1-1/4-inch	2-inch
Hot Water Circulation Piping Above Grade (141F to 200F)	1	Runouts up to 1-1/2-inch	1-inch
		Mains =<1-1/4-inch	1-1/2-inch
		Mains >1-1/4-inch	2-inch
Cold Water Piping Above Grade	1	=<1-1/2-inch	1/2-inch
		>1-1/2-inch	1-inch
Hot Water Piping Below Grade	2	=<1-1/2-inch	1-inch
		>1-1/2-inch	1-1/2-inch

Hot Water Circulation Piping Below Grade	2	≤1-1/2-inch	1-inch
		>1-1/2-inch	1-1/2-inch
Water Piping Exposed to Weather	1, 2, 4	All	1-1/2-inch
Piping with Heat Tracing	1, 2, 4	≤1-1/2-inch	1-inch
		>1-1/2-inch	1-1/2-inch
Above Grade Roof Drain/Overflow Drain Piping	1, 2	All	1/2-inch
Roof Drain Underbodies	5, 6	N/A	1-inch
Overflow Roof Drain Underbodies	5, 6	N/A	1-inch
ADA Accessible Lavatory/Sink	7	All	As Listed
Storage Tanks	3, 5	All	2-inch
Condensate Drain Piping	1, 2	All	1/2-inch
Aboveground Refrigerated Water Systems	1, 2	All	1-inch
Solar Hot Water and Glycol Piping	1,4	≤1-1/2-inch	1-inch
		>1-1/2-inch	1-1/2-inch

3.2 TYPE 1, GLASS WOOL PIPE INSULATION

- A. See General Installation Requirements above.
- B. Install in accordance with manufacturer's instructions for below grade installation.
- C. Lap seal insulation with waterproof adhesive. Do not use staples or other methods of attachment which would penetrate vapor barrier. Apply fitting covers with seated tacks and vapor barrier tape.
- D. Apply insulation to pipe and seal with self-sealing lap. Use self-sealing butt strips to seal butt joints. Insulate fittings, valves and unions with single or multiple layers of insulation and cover to match pipe or use preformed PVC molded insulation covers.
- E. Above Grade Roof Drain/Overflow Drain Piping: Cover all roof drain piping and overflow drain piping with sectional pipe covering.

3.3 TYPE 2, FLEXIBLE ELASTOMERIC INSULATION

- A. See General Installation Requirements above.
- B. Install in accordance with manufacturer's instructions for below grade installation.

- C. Slip insulation on pipe prior to connection. Butt joints sealed with manufacturer's adhesive. Insulate fitting with miter-cut pieces. Cover insulation exposed to weather and undergrade with two coats of finish as recommended by manufacturer.
- D. Above Grade Roof Drain/Overflow Drain Piping: Cover all roof drain piping and overflow drain piping with sectional pipe covering.
- E. Flexible Elastomeric Tubing: Slip insulation over piping or if piping is already installed, it should be slit and snapped over piping. Joints and butt ends must be adhered with 520 adhesive.

3.4 TYPE 5, GLASS WOOL EQUIPMENT INSULATION

- A. See General Installation Requirements above.
- B. Apply insulation and accessories to roof drain underbodies per manufacturer's recommendations.
- C. Roof Drain/Overflow Drain Underbodies: Cover underside of drain body with glass wool insulation; attached with adhesive and supported externally with 26 gauge galvanized flat strapping anchored to structure.
- D. Storage Tanks: Cover with glass wool, 2-inches thick. Finish with canvas jacket and adhesive. Overlap joints minimum of 4-inches. Apply two coats latex paint; color selected by Architect.

3.5 TYPE 7, ADA ACCESSIBLE LAVATORY/SINK INSULATION KIT

- A. See General Installation Requirements above.
- B. Install in accordance with manufacturer's instructions.
- C. Provide lavatory/sink insulation kit. Install on waste fittings, hot and cold water stops and supplies.

3.6 ACCESSORIES

- A. See General Installation Requirements above.
- B. Install in accordance with manufacturer's instructions.
- C. Furnish and install accessories for all insulation types listed in this Section.

3.7 PIPE FITTING INSULATION COVERS

- A. See General Installation Requirements above.
- B. Install in accordance with manufacturer's instructions.

END OF SECTION

SECTION 22 0800 - COMMISSIONING OF PLUMBING

PART 1 - GENERAL

1.1 SUMMARY

A. Work Included:

1. See Division 01, General Requirements for overall objectives and comply with requirements.
 - a. This section covers the Contractor's responsibilities for commissioning; installer responsible for installation of a particular system or equipment item to be commissioned is responsible for commissioning activities relating to that system or equipment item.
 - b. Pre-Functional Checklist and Functional Test requirements specified in this Section are in addition to, not a substitute for, inspection or testing specified in other sections.

1.2 RELATED SECTIONS

- A. Contents of Division 22, Plumbing and Division 01, General Requirements apply to this section.

1.3 REFERENCES AND STANDARDS

- A. References and Standards as required by Section 22 00 00, Plumbing Basic Requirements and Division 01, General Requirements.
- B. Meet requirements of ASHRAE Guideline 0, The Commissioning Process.

1.4 SUBMITTALS

- A. Submittals as required by Section 22 00 00, Plumbing Basic Requirements and Division 01, General Requirements.
- B. In addition, provide Pressure Tests, Flushing Reports, and Startup Reports. Submit for approval of Commissioning Authority.

1.5 QUALITY ASSURANCE

- A. Quality assurance as required by Section 22 00 00, Plumbing Basic Requirements and Division 01, General Requirements.

1.6 WARRANTY

- A. Warranty of materials and workmanship as required by Section 22 00 00, Plumbing Basic Requirements and Division 01, General Requirements.
- B. In addition, provide:
 1. Commissioning, inspecting, and testing will not modify terms or time periods of mechanical equipment, systems, and controls warranties including related equipment and system, and adjacent work.

2. Control system warranty period starts from date of Commissioning Agent acceptance.

1.7 COORDINATION

- A. Reference Section 01 91 13, General Commissioning Requirements for requirements pertaining to coordination during the commissioning process.

1.8 PURPOSE

- A. Purpose of commissioning process is to provide Owner assurance that systems have been installed in prescribed manner and will operate within performance guidelines. Commissioning is intended to enhance quality of system startup and aid in orderly transfer of systems to beneficial use by Owner.
- B. Commissioning procedures and results will be observed by Commissioning Authority or Owner's staff. Contractor is expected to verify functional readiness of systems to be tested prior to performing the tests in presence of Owner's witness. A high rate of test failure will indicate that Contractor has not adequately verified readiness of systems.

PART 2 - PRODUCTS

2.1 TEST EQUIPMENT

- A. Provide standard testing equipment required to perform startup and initial checkout and required functional performance testing; unless otherwise noted such testing equipment will NOT become property of Owner.
- B. Specialized tools, test equipment, and instruments required to execute Start-up, checkout, and testing of equipment are to be of sufficient quality and accuracy to test and/or measure system performance within specified tolerances. A testing laboratory must have calibrated its test equipment within the previous 12 months. Calibration to be NIST traceable. Contractor must calibrate test equipment and instruments according to manufacturer's recommended intervals and whenever the test equipment is dropped or damaged. Calibration tags must be affixed to the test equipment or certificates readily available.
- C. Equipment-Specific Tools: Where special testing equipment, tools and instruments are specific to a piece of equipment, are only available from the vendor, and are required in order to accomplish startup or Functional Testing, provide such equipment, tools, and instruments as part of the work at no extra cost to Owner; such equipment, tools, and instruments are to become property of Owner.

PART 3 - EXECUTION

3.1 PREPARATION

- A. Cooperate with Commissioning Authority in development of the Pre-Functional Checklists and Functional Test Procedures.
- B. As part of required submittals for contract, within three months of award of contract, submit for each piece of equipment and controls, manufacturer's startup and installation procedures as well as controls point-to-point and sequence checkout and provide in check list format.

- C. Furnish additional information requested by the Commissioning Authority.
- D. Prepare a preliminary schedule for plumbing pipe systems testing, flushing and cleaning, equipment start-up and testing, adjusting, and balancing start and completion for use by the Commissioning Authority; update schedule as appropriate.
- E. Notify Commissioning Authority when pipe system testing, flushing, cleaning, startup of each piece of equipment and testing, adjusting, and balancing will occur; when commissioning activities not yet performed or not yet scheduled will delay construction notify ahead of time and be proactive in seeing that Commissioning Authority has scheduling information needed to efficiently execute commissioning process.
- F. Put equipment and systems into operation and continue operation during each working day of testing, adjusting, and balancing and commissioning, as required.
- G. Provide temperature and pressure taps in accordance with Contract Documents.
- H. Provide a pressure/temperature plug at each water sensor which is an input point to control system.

3.2 CONTRACTOR'S RESPONSIBILITIES

- A. Perform commissioning tests at the direction of the Commissioning Authority.
- B. Participate in Plumbing systems, assemblies, equipment, and component maintenance orientation and inspection as directed by the Commissioning Authority.
- C. Provide information requested by the Commissioning Authority for final commissioning documentation.
- D. Include requirements for submittal data, operation and maintenance data, and training in each purchase order or sub-contract written.
- E. Prepare preliminary schedule for Plumbing system orientations and inspections, operation and maintenance manual submissions, training sessions, pipe and duct system testing, flushing and cleaning, equipment startup, testing and balancing and task completion for Owner. Distribute preliminary schedule to commissioning team members.
- F. Update schedule as required throughout the construction period.
- G. During the startup and initial checkout process, execute the related portions of the Pre-Functional Checklists for commissioned equipment.
- H. Contractor to participate and complete checklists using the Commissioning Authority's web based commissioning software Facility Grid. A desktop, laptop, tablet, or iPad will be required.
- I. Assist the Commissioning Authority in verification and Functional Performance Tests.
- J. Gather operation and maintenance literature on equipment and assemble in binders as required by the Specifications. Submit to Commissioning Authority 45 days after substantial completion.

- K. Coordinate with the Commissioning Authority to provide 48 hour advance notice so that the witnessing of equipment and system startup and testing can begin.
- L. Notify the Commissioning Authority a minimum of one week in advance of the time for the start of the balancing work.
- M. Participate in, and schedule vendors and contractors to participate in the training sessions.
- N. Provide written notification to the CM/GC and Commissioning Authority that the following work has been completed in accordance with the Contract Documents, and that the equipment, systems, and sub-system are operating as required.
 - 1. Plumbing equipment including domestic water heaters, pumps, plumbing fixtures, and other equipment furnished under this Division.
 - 2. Gas piping, sanitary waste and vent piping, storm drainage piping, sump pumps and automatic sprinkler system.
- O. Provide training of the Owner's operating staff using expert qualified personnel, as specified.
- P. Reference Section 01 91 13, General Commissioning Requirements, for additional contractor responsibilities.

3.3 OWNER'S RESPONSIBILITIES

- A. Reference Section 01 91 13, General Commissioning Requirements for Owner's responsibilities.

3.4 DESIGN PROFESSIONAL'S RESPONSIBILITIES

- A. Reference Section 01 91 13, General Commissioning Requirements for the Architect, Mechanical, Electrical, and Plumbing Engineer's responsibilities.

3.5 COMMISSIONING AUTHORITY'S RESPONSIBILITIES

- A. Reference Section 01 91 13, General Commissioning Requirements for the Commissioning Authority's responsibilities.

3.6 TESTING PREPARATION

- A. Certify, in writing, to the Commissioning Authority that plumbing instrumentation and control systems have been completed and calibrated, that they are operating according to the Contract Documents, and that pre-test setpoints have been recorded.
- B. Certify, in writing, that discrepancies discovered during the test and balance process have been resolved and that testing, adjusting, and balancing is completed.
- C. Set systems, subsystems, and equipment into operating mode to be tested (e.g. normal auto position, normal manual position, unoccupied mode, emergency power and alarm conditions).
- D. Inspect and verify the position of each device and interlock identified on checklists.

- E. Check safety cutouts, alarms, and interlocks with smoke control and life-safety systems during each mode operation.

3.7 TAB COORDINATION

- A. TAB: Testing, adjusting, and balancing of Plumbing.
- B. Coordinate commissioning schedule with TAB schedule.
- C. Review the TAB plan to determine capabilities of the control system toward completing TAB.
- D. Provide necessary unique instruments and instruct TAB technicians in their use; such as handheld control system interface, etc.
- E. Have required Pre-Functional Checklists, calibrations, startup and component Functional Tests of the system completed and approved by Commissioning Authority prior to starting TAB.
- F. Provide a qualified control system technician to operate controls to assist TAB technicians or provide sufficient training for TAB technicians to operate system without assistance.

3.8 GENERAL TESTING REQUIREMENTS

- A. Provide technicians, instrumentation, and tools to perform commissioning test at the direction of Commissioning Authority.
- B. Scope of Plumbing testing to include entire Plumbing installation. Testing to include measuring capacities and effectiveness of operational and control functions.
- C. Test operating modes, interlocks, control responses, and responses to abnormal or emergency conditions, and verify proper response of building automation system controllers and sensors.
- D. The Commissioning Authority along with the Plumbing contractor, balancing subcontractor to prepare detailed testing plans, procedures, and checklists for Plumbing systems, subsystems, and equipment.
- E. Tests will be performed using design conditions whenever applicable.
- F. Simulated conditions may need to be imposed using an artificial load when it is not practical to test under design conditions. Before simulating conditions, calibrate testing instruments. Provide equipment to simulate loads. Set simulated conditions as directed by the Commissioning Authority and document simulated conditions and methods of simulation. After tests, return settings to normal operating conditions.
- G. The Commissioning Authority may direct that setpoints be altered when simulating conditions is not practical.
- H. The Commissioning Authority may direct that sensor values be altered with a signal generator when design or simulating conditions and altering setpoints are not practical.

- I. If tests cannot be completed because of a deficiency outside the scope of the Plumbing system, document the deficiency and report it to the Owner. After deficiencies are resolved, reschedule tests.

3.9 PLUMBING SYSTEMS, SUBSYSTEMS AND EQUIPMENT TESTING PROCEDURES

- A. Pipe system cleaning, flushing, hydrostatic tests, and chemical treatment: Test requirements are specified in Division 22, Plumbing Piping sections. Plumbing Contractor to prepare a pipe system cleaning, flushing, and hydrostatic testing plan. Provide cleaning, flushing, testing, and treating plan and final reports to the Commissioning Authority. Plan should include the following.
 1. Sequence of testing procedures for each section of pipe to be tested, identified by pipe zone or sector identifications marker. Markers to be keyed to Drawings for each pipe sector, showing the physical location of each designated pipe test section. Drawings keyed to pipe zones or sectors to be formatted to allow each section to be physically located and identified when referred to in pipe system cleaning, flushing, hydrostatic testing, and chemical treatment plan.
 2. Description of equipment for flushing operations.
 3. Minimum flushing velocity.
- B. Functional Performance Tests: Tests will be fully documented with test procedures, expected results for each procedure, and documented in either pass or fail. Tests are written by the Commissioning Authority and performed by the Contractor. The Commissioning Authority documents the results of the test.

3.10 DEFICIENCIES / NON-CONFORMANCE AND COST OF RETESTING

- A. The Commissioning Authority documents the results of the tests. Corrections of minor deficiencies identified are made during the tests at the discretion of the Commissioning Authority. The Commissioning Authority documents the testing results on the Functional Performance Testing document. Deficiencies or non-conformance issues are noted and reported to the GC and Owner via the Master Cx Issues/Resolutions Log. The Contractor with then correct deficiencies, notify the Commissioning Authority of the correction, and then schedule retesting of the issue with the GC and Commissioning Authority. For areas in dispute of the issue between the Commissioning Authority and Contractor to go directly to the A/E. A/E to provide direction of the design intent and expected result to clear up the dispute.
- B. If the Plumbing contractor fails to demonstrate proper sequence of operation in any of the second round of Functional Performance Tests, the Commissioning Authority's costs for witnessing further demonstration of that test procedure may be assigned to the Plumbing contractor by the Owner as a deduct to their contracted price. The Plumbing contractor will not be responsible for costs related to failure due to design or other factors beyond their control, though it is expected to call any design concerns (and other factors beyond their control that might cause failure) to the attention of the GC and Commissioning Authority.
- C. Reference Section 01 91 13, General Commissioning Requirements for additional contractor responsibilities

3.11 OPERATION AND MAINTENANCE MANUALS

- A. See Division 01, General Requirements for additional requirements.
- B. Submit manuals related to items that were commissioned to Commissioning Authority for review; make changes recommended by Commissioning Authority.
- C. Commissioning Authority will add commissioning records to manuals after submission to Owner.

3.12 DEMONSTRATION AND TRAINING

- A. See Division 01, General Requirements for additional requirements.
- B. Demonstrate operation and maintenance of Plumbing systems to Owner's personnel; if during any demonstration, system fails to perform in accordance with information included in Operations and Maintenance (O&M) manual, stop demonstration, repair or adjust, and repeat demonstration. Demonstrations may be combined with training sessions if appropriate.
- C. These demonstrations are in addition to, and not a substitute for, Pre-Functional Checklists and demonstrations to Commissioning Authority during Functional Testing.
- D. Training:
 - 1. Submit a written training plan to the Owner and Architect/Engineer for review and approval. Contractor's training plan to cover the following elements:
 - a. Equipment included in training.
 - 1) Intended audience.
 - 2) Location of training.
 - 3) Objectives.
 - b. Subjects covered.
 - c. Duration of training on each subject.
 - d. Instructor for each subject.
 - e. Methods (classroom lecture, video, Site walk-through, actual operational demonstrations, written hand outs, etc.).
 - f. Instructors and qualifications.
 - 2. Contractor is to have the following training responsibilities:
 - a. Provide a training plan ten calendar days prior to the scheduled training, in accordance with Division 01, General Requirements.
 - b. Provide Owner personnel with comprehensive training in the understanding of the systems and the operation and maintenance of each major piece of commissioned mechanical equipment or system.
 - c. Training to start with classroom sessions, if necessary, followed by hands-on training on each piece of equipment, which will illustrate the various modes of operation, including start-up, shutdown, fire/smoke alarm, power failure, etc.
 - d. During any demonstration, should the system fail to perform in accordance with the requirements of the O&M manual or sequence of operations, the system will be repaired or adjusted as necessary and the demonstration repeated.
 - e. The appropriate trade or manufacturer's representative will provide the instructions on each major piece of equipment. This representative may be the Start-up

technician for the piece of equipment, the installing contractor, or the manufacturer's representative. Practical building operating expertise, as well as in-depth knowledge of modes of operation of the specific piece of equipment, is required. More than one party may be required to execute the training.

- E. Provide the services of manufacturer representatives to assist instructors where necessary.

END OF SECTION

SECTION 22 1000 - PLUMBING PIPING

PART 1 - GENERAL

1.1 SUMMARY

A. Work Included:

1. Sanitary, Drainage (Rain/Stormwater) DWV Piping, Buried Within 5-feet of Building
2. Sanitary, Drainage (Rain/Stormwater) DWV Piping, Above Grade
3. Pump Waste Pressure Piping (Pumped Discharge)
4. Water Piping, Buried Within 5-feet of Building
5. Hot and Cold Domestic Water Above Grade
6. Condensate Piping
7. Primer Piping
8. Cleanouts

1.2 RELATED SECTIONS

- A. Contents of Division 22, Plumbing and Division 01, General Requirements apply to this Section.

1.3 REFERENCES AND STANDARDS

- A. References and Standards as required by Section 22 00 00, Plumbing Basic Requirements and Division 01, General Requirements.
- B. In addition, meet the following:
 1. NSF 61, Annex G.
 2. Steel pipe to conform to ASTM and ANSI Standards as specified in this Section.
 3. Copper piping to conform to ASTM B88, B306 and B208 and the standards of Copper Development Association (CDA), and American Welding Society, (AWS).
 4. Cast Iron Piping to conform to standards of ASTM A-74, CISPI 301 and FM 1680.
 5. Manufacturer's Standards Society (MSS) for valving and support reference standard.
 6. American Water Works Association (AWWA) for Valving Assembly Standards.
 7. American Society of Sanitation Engineers (ASSE) for Valving Standards.
 8. American National Standards Institute (ANSI) for Piping Standards.
 9. NFPA Standard 51B - "Fire Prevention in Use of Cutting and Welding Processes".
 10. Crosslinked polyethylene (PEX) pipe conforming to ASTM F876, F877 and CSA B1375, or DIN 16892 and 16893.

1.4 SUBMITTALS

- A. Submittals as required by Section 22 00 00, Plumbing Basic Requirements and Division 01, General Requirements.

1.5 QUALITY ASSURANCE

- A. Quality assurance as required by Section 22 00 00, Plumbing Basic Requirements and Division 01, General Requirements.

1.6 WARRANTY

- A. Warranty of materials and workmanship as required by Section 22 00 00, Plumbing Basic Requirements and Division 01, General Requirements.

PART 2 - PRODUCTS

2.1 MANUFACTURERS

- A. See component manufacturers listed in individual articles below.
- B. ADS
- C. American-USA
- D. Cerro
- E. Charlotte
- F. Clamp-All
- G. Elkhart
- H. Enfield
- I. Fusesal
- J. Gruvlok
- K. Husky
- L. Ideal
- M. Mission
- N. Mueller
- O. Nibco
- P. Orion
- Q. Sioux Chief
- R. Spears
- S. Tyler
- T. Uponor
- U. Viega

- V. Or approved equivalent.
- W. Cleanouts:
 - 1. J.R. Smith
 - 2. Zurn
 - 3. Wade
 - 4. Watts
 - 5. Sioux Chief
 - 6. Or approved equivalent.
- X. Firestopping Penetrations in Fire Rated Wall Floor Assemblies:
 - 1. Hilti
 - 2. Proset
 - 3. Or approved equivalent.

2.2 GENERAL

- A. Provide pipe, tube and fittings of the same type, fitting requirements, grade, class and the size and weight indicated or required for each service, as indicated in other Division 22, Plumbing Specifications. Where type, grade, or class is not indicated, provide proper selection as determined by installer for installation requirements, and comply with governing regulations and industry standards.
- B. Manufactured materials delivered, new to the project site and stored in their original containers.
- C. Product Marking: Furnish each item with legible markings indicating name brand and manufacturer, manufacturing process, heat number and markings as required per ASTM and UL/FM Standards.

2.3 SANITARY, DRAINAGE (RAIN/STORMWATER) DWV PIPING, BURIED WITHIN 5-FEET OF BUILDING

- A. Cast Iron Pipe: ASTM A888/CISPI 301 hubless.
 - 1. Fittings: Cast iron.
 - 2. Coupling Assembly:
 - a. Heavy Duty: ASTM C1540, Clamp-All Hi-Torq 125, Husky SD 4000, Mission HeavyWeight couplings.
- B. Copper Tube: ASTM B 306, DWV
 - 1. Fittings: ASME B16.29, wrought copper.
 - 2. Joints: ASTM B32, ASTM B-828 and alloy Sn50 solder.
 - 3. Flux: ASTM B813-91, water soluble.
- C. PVC Pipe: ASTM D 2665 IPS Schedule 40, **SOLID WALL** piping for drainage/waste and vent (DWV).
 - 1. Fittings: PVC DWV ASTM D2665.
 - 2. Joints: Solvent welded, with ASTM D2564 solvent cement, 2-step glue (primer and glue) is required.

2.4 SANITARY, DRAINAGE (RAIN/STORMWATER) DWV PIPING, ABOVE GRADE

- A. Cast Iron Pipe: ASTM A888/CISPI 301 hubless.
 - 1. Fittings: Cast iron.
 - 2. Coupling Assembly:
 - a. Standard Duty: ASTM C1277 or CISPI 310.
- B. Copper Tube: ASTM B 306, DWV
 - 1. Fittings: ASME B16.29, wrought copper.
 - 2. Joints: ASTM B32, alloy Sn50 solder.

2.5 PUMP WASTE PRESSURE PIPING (PUMPED DISCHARGE)

- A. Above Grade : Type "L" copper with solder joints.
- B. Below Grade: Type "L" copper with brazed joints.

2.6 WATER PIPING, BURIED WITHIN 5-FEET OF BUILDING

- A. Copper Pipe: ASTM B88, hard drawn, Type K (A).
 - 1. Fittings: ASME B16.18, cast copper alloy or ASME B16.22 wrought copper and bronze.
 - 2. Joints: Brazed - BCuP2.
- B. Ductile Iron Pipe: AWWA C151/A21.51.
 - 1. Fittings: Ductile or gray iron, standard thickness.
 - 2. Joints: AWWA C111/A21.11, rubber gasket with 3/4-inch diameter rods, mega lug type.

2.7 HOT AND COLD DOMESTIC WATER ABOVE GRADE

- A. Copper Tube: 3-inches and above. ASTM B88 (ASTM BA88m), Type K (A), Drawn.
 - 1. Fittings: ASME B16.18, cast copper alloy or ASME B16.22, wrought copper and bronze.
 - 2. Joints: Brazed BCuP2.
- B. Copper Tube: 2-1/2-inches and smaller. ASTM B88 (ASTM B88M), Type L (B), Drawn.
 - 1. Fittings: ASME B16.18 copper.
 - 2. Joints: ASTM B32, alloy Sn95 solder.
- C. Copper Tube: Water pressures up to 250 PSI gauge. ASTM B 88 (ASTM BA 88m), Type K (A), Drawn.
 - 1. Fittings: ASME B16.18, cast copper alloy or ASME B16.22, wrought copper and bronze.
 - 2. Joints: Brazed BCuP2.
- D. Stainless Tube:
 - 1. Piping 3-inch and Larger: Grade H, ASTM A268/A268M-91, roll-grooved joint.
 - 2. Fittings: Schedule 10S Type 304L stainless steel fittings, ISO 9001, ASTM A-403.
 - 3. Couplings: Anvil or Gruvlok grooved system, IPS stainless steel grooved coupling with EPDM gasket, stainless steel nuts and bolts, ASTM-A351, A743 AND A744-CF-8M, ISO 9001.

- E. Copper Tube: ASTM B88 (ASTM B88M), Type K (A), Drawn.
 - 1. Fittings: ASME B16.22, wrought copper.
 - 2. Joints: Roll grooved mechanical coupling. ASTM A536.

- F. Cross-Linked Polyethylene Tubing, Fittings and Accessories (except exposed locations).
 - 1. Tubing:
 - a. Cross-linked polyethylene (PEX) tubing complies with requirements of ASTM F876 and F877, and cross-linking method must be Type A (hot)method.
 - b. PEX tubing to have minimum working pressure of not less than 160 PSI for water at 73.4 degrees F, 100 PSI for water at 180 degrees F and 80 PSI for water at 200 degrees F determined in accordance with Plastic Pipe Institute Technical Report TR-3/92, and listed in Plastic Pipe Institute Technical Report TR-4/95.
 - 2. Fittings:
 - a. Fittings: Engineered Plastic Fittings for above grade applications. Engineered plastic fittings for below grade applications. Serrated type with reinforcement rings.
 - b. Reinforcement Rings: Manufactured using "Engel Method" to ensure that viscoelastic stress regenerative properties are sufficient to produce pressure tight seal.
 - c. Fitting Insert: Of such dimension in that tubing must be expanded in order to facilitate insertion of fitting into tube.
 - d. Accomplish expansion of tubing and ring by an expansion tool designed expressly for that purpose.
 - e. Fittings complies with requirements of ASTM F877.
 - 3. Manifolds: Provide premanufactured copper manifolds of same manufacturer as piping.
 - 4. Stub-out Ells and Stub-out Brackets: Provide premanufactured Type L copper stub-out ells and copper stub-out brackets.

2.8 CONDENSATE PIPING

- A. Copper Tube: ASTM B 88 (ASTM B898M), Type K (A), L (B), or M (C).
 - 1. Fittings: ASME B16.29, wrought copper.
 - 2. Joints: ASTM B32, alloy Sn50 solder.

- B. Use chemical resistant piping for drainage of condensate from combustion fuel sources (such as condensing boilers and water heaters), as noted in this Section for area of application.

- C. CPVC (Chlorinated Poly Vinyl Chloride) Pipe and Fittings:
 - 1. Pipe and Fittings: Schedule 40, NSF-14, ASTM 439, IAPMO IS20-96, socket fittings, solvent weld.

2.9 PRIMER PIPING

- A. Above Ground: Type L hard-drawn copper tubing with wrought sweat fittings and soldered joints.

- B. Below Ground: Type L soft annealed copper tubing with wrought sweat fittings and brazed joints.

- C. Below Ground: Cross-linked polyethylene (PEX) and engineered plastic fittings.

2.10 CLEANOUTS

- A. Locate cleanouts as shown on Drawings and as required by local code. Cleanouts same size as pipe except that greater than 4-inches will not be required. Plastic components not allowed, except unless specifically noted.
- B. Types:
 - 1. Tile Floor Cleanouts: J. R. Smith 4020 with round heavy-duty nickel bronze top, taper thread, ABS plug and standard screws.
 - 2. Carpeted Floor Cleanout: J. R. Smith 4020-X with carpet clamping frame, round heavy-duty nickel bronze top, taper thread, ABS plug, carpet clamping device and standard screws.
 - 3. Concrete Floor Cleanout (General): J. R. Smith 4020 with round heavy-duty nickel bronze top, taper thread and ABS plug with standard screws.
 - 4. Parking, Drives and Concrete Floor Cleanouts (Heavy Load): J. R. Smith 4100 with round heavy-duty nickel bronze top, taper thread and ABS plug with standard screws.
 - 5. Wall Cleanout: J. R. Smith 4472-U, countersunk bronze taper thread plug, stainless steel shallow cover and vandalproof screws.
 - 6. Outside Area Walks: J. R. Smith 4020-U with round heavy-duty nickel bronze top, taper thread, ABS plug and top secured with vandalproof screws. Install in 18- by 18- by 6-inch deep concrete pad flush with grade.

PART 3 - EXECUTION

3.1 GENERAL INSTALLATION REQUIREMENTS

- A. Underground Piping Systems:
 - 1. Examination: Verify that excavations are to required grade, dry, and not over-excavated.
 - 2. Perform necessary excavation and backfill required for installation of plumbing work. Repair piping or other work at no expense to Owner.
 - 3. Water: Keep excavations free of standing water. Re-excavate and fill back excavations damaged or softened by water or frost to original level with sand, crushed rock or other approved material at no expense to Owner.
 - 4. Tests: During progress of work for compacted fill, Owner reserves right to request compaction tests made under direction of testing laboratory.
 - 5. Trench Excavation: Excavate trenches to necessary depth and width, removing rocks, unstable soil (muck, peat), roots and stumps. Excavation material is classified as "base fill" and "native." Base fill excavation material consisting of placed crushed rock may be used as backfill above "Pipe Zone." Remove and dispose off site native excavation material. Adequate width of trench for proper installation of piping or conduit.
 - 6. Support Foundations:
 - a. Foundations: Excavate trenches located in unstable ground areas below elevation required for installation of piping to depth which is determined by Architect as appropriate for conditions encountered. Place and compact approved foundation material in excavation up to "Bedding Zone." Dewatering, placement, compaction and disposal of excavated materials to conform to requirements contained in other Specification Sections or Drawings.

- b. Over-Excavations: Where trench excavation exceeds required depths, provide, place and compact suitable bedding material to proper grade or elevation at no additional cost to Owner.
- c. Foundation Material: Where native material has been removed, place and compact necessary foundation material to form base for replacement of required thickness of bedding material.

	Class A		Class B	
Material Passing	Min.	Max.	Min.	Max.
3/4-inch Square Opening	27	47	0	1

- d. Bedding Material: Full bed piping on sand, pea gravel, or 3/4-inch minus crushed rock. Place minimum 4-inch deep layer of sand, pea gravel, or crushed rock on leveled trench bottom for this purpose. Remove bedding to necessary depth for piping bells and couplings to maintain contact of pipe on bedding for its entire length. Provide additional bedding in excessively wet, unstable, or solid rock trench bottom conditions as required to provide firm foundation.
7. Backfilling:
- a. Following installation and successful completion of required tests, backfill piping in lifts.
 - 1) In "Pipe Zone" place backfill material and compact in lifts not to exceed 6-inches in depth to height of 12-inches above top of pipe. Place backfill material to obtain contact with entire periphery of pipe, without disturbing or displacing pipe.
 - 2) Place and compact backfill above "Pipe Zone" in layers not to exceed 12-inches in depth.
 - b. Backfill Material:
 - 1) Backfill Material in "Pipe Zone": 3/4-inch minus crushed rock, sand or pea gravel.
 - 2) Crushed rock, fill sand or other backfill material approved elsewhere in Specifications may be used above "Pipe Zone."
8. Compaction of Trench Backfill:
- a. Where compaction of trench backfill material is required, use one of following methods or combination thereof:
 - 1) Mechanical tamper,
 - 2) Vibratory compactor, or
 - 3) Other approved methods appropriate to conditions encountered.
 - b. Architect to have right to change methods and limits to better accommodate field conditions. Compaction sufficient to attain 95 percent of maximum density at optimum moisture content unless noted otherwise on Drawings or elsewhere in Specifications. Water "puddling" or "washing" is prohibited.

B. General Installation:

- 1. Work performed by experienced journeyman plumbers. No exceptions.
- 2. Provide access panels for concealed valves, shock arrestors, trap primers and the like.

3. Install pipes and pipe fittings in accordance with recognized industry practices and manufacturer's recommendations.
4. Align piping accurately at connections, within 3/32-inch misalignment tolerance. Comply with ANSI B31 Code for Pressure Piping.
5. Locate piping runs, as indicated, vertically and horizontally (pitched to drain) and avoid diagonal runs wherever possible. Orient horizontal runs parallel with walls and column lines. Locate runs as shown or described by diagrams, details, and notations or, if not otherwise indicated, run piping in shortest route which does not obstruct space or block access for servicing building and its equipment. Hold piping close to walls, overhead construction, and other structural and permanent-enclosure elements of building. Limit clearance to 1/2-inch where furring is shown for enclosure or concealment of piping, but allow for insulation thickness, if any. Where possible, locate insulated piping for 1-inch clearance outside insulation. Whenever possible in finished and occupied spaces, conceal piping from view by locating it in column enclosures, hollow wall construction or above suspended ceilings. Do not encase horizontal runs in solid partitions, except as indicated.
 - a. Do not run piping through transformer vaults, telephone, elevator, electrical or electronic equipment spaces or enclosures unless indicated on Drawings.
 - b. Concealed Piping Above Suspended Ceiling: Plan and coordinate to avoid interferences; install to maintain suspended ceiling heights shown on Architectural Drawings. Allow sufficient space above removable ceiling panels for panel removal. Locate piping so that valves are visible and accessible within 24-inches horizontally and vertically from point of access to the ceiling space. Provide plenum rated materials for ceiling spaces which are being used as plenums.
 - c. Exposed Work: Run pipes parallel to the closest wall unless otherwise shown on Drawings; maintain maximum headroom; avoid light fixtures.
 - d. Insulation Space Allowance: In piping work, allow space for pipe insulation and jackets. If interferences occur, move the piping to accommodate insulation thickness specified.
 - e. Pipe Lengths: Do not use short lengths or nipples at locations where a full length of pipe will fit.
 - f. Alignment Prior to Supporting and Anchoring: Place piping in proper alignment and position prior to connection to anchors, expansion loops, and equipment. Furnish jacking devices, temporary steel structural members, and assembled structures as necessary. Remove temporary equipment and structures supplied by contractor at completion; such items to remain Contractor property.
 - g. Valve and Equipment Connections: Piping not to place undue stress on flanged valves and equipment connections. Install mating flange faces true and parallel to each other and not requiring springing of piping for assembly. Pipe hangers and supports to carry the full weight of the pipe and fluid.
 - h. Piping Leaks: Correct immediately; use new materials; leak-sealing compounds or peening not permitted.
 - i. Pressure Ratings of Fittings, Valves, and Devices in Piping Systems: Pressure rating to be equal to, or greater than, the maximum working pressure of the system.
 - j. Equipment Vents and Drains: Provide for coils and vessels which contain water. Provide isolation valves and outlet valves at piping high and low points to permit venting and draining of the vessel without venting and draining connected piping. Provide hose connections and caps on drain lines.
 - k. Escutcheon Plates: Where exposed insulated and uninsulated piping passes through walls, floors or ceilings; provide spring clip type. Provide plates on both sides of wall or floor.

- C. Testing:
1. General:
 - a. Provide temporary equipment for testing, including pumps, compressors, tanks, and gauges, as required. Test piping systems before insulation (if any) is installed and remove or disengage control devices before testing. Where necessary, test sections of each piping system independently, but do not use piping valves to isolate sections where test pressures exceed local valve operating pressure rating. Fill each section with water, compressed air, or nitrogen and pressurize for the indicated pressure and time.
 - b. Notify Architect and local Plumbing Inspector 2 days before tests.
 - c. Drainage, Waste and Vent Piping: Test in accordance with governing plumbing code or as follows: Test drainage and venting systems, with necessary openings plugged, to permit system to be filled with water and subjected to water pressure of minimum of 5 PSI head. System to hold water without water level drop greater than 1/2 pipe diameter of largest nominal pipe size within 24-hour period. Test system in sections if minimum head cannot be maintained in each section. 5 PSI head to be minimum pressure at highest joint.
 - d. Water Piping: Eliminate air from system. Fill and test at 125 PSIG or minimum 1-1/2 times static pressure at connection to serving utility main for period of two hours with no loss in pressure.
 - e. Send test results to Architect for review and approval and include in Operation and Maintenance Manual.
 2. Testing of Pressurized Systems:
 - a. Test each pressurized piping system at 150 percent of operating pressure indicated, but not less than 125 PSIG test pressure.
 - b. Observe each test section for leakage at end of test period. Test fails if leakage is observed or if pressure drop exceeds 2 percent of test pressure.
 3. Test hot and cold domestic water piping systems upon completion of rough-in and before connection to fixtures at hydrostatic pressure of 125 PSIG.
- D. Corrosive Soil Conditions:
1. Wrap steel, iron, copper or other metal piping materials/fittings with Protecto Wrap 200, 30 mils or greater. Maintain a 1/2-inch overlap and install per manufacturer's recommendations.
 2. Provide epoxy coated cast iron pipe and fittings for drainage systems.
 3. Obtain and review project soils report for verification of requirements concerning corrosive soils.
- E. Protection:
1. Keep pipe openings closed by means of plugs or caps to prevent entrance of foreign matter. Protect piping, ductwork, fixtures, equipment and apparatus against dirty water, chemical or mechanical damage both before and after installation. Restore to its original condition or replace fixtures, equipment or apparatus damaged prior to final acceptance of work.
- F. Firestopping Penetrations in Fire-Rated Wall/Floor Assemblies:
1. Provide proper sizing when providing sleeves or core-drilled holes to accommodate penetration. Firestop voids between sleeve or core-drilled hole and pipe passing through to meet requirements of ASTM E814.

- G. Cut piping squarely, free of rough edges and reamed to full bore. Insert piping fully into fittings.
- H. Provide joints of type indicated in each piping system.
- I. Thread pipe in accordance with ANSI/ASME B1.20.1. Cut threads full and clean using sharp dies. Ream threaded ends to remove burrs and restore full inside diameter. Remove excess cutting oil from piping prior to assembly. Apply pipe joint compound, or pipe joint tape (Teflon) where recommended by pipe/fitting manufacturer, on male threads at each joint and tighten joint to leave not more than 3 threads exposed.
- J. Sleeves:
 - 1. Pipe Sleeves:
 - a. Layout work in advance of pouring concrete, furnish, and set sleeves necessary to complete work.
 - b. Floor Sleeves: Provide sleeves on pipes passing through concrete or masonry construction. Extend sleeve 1-inch above finished floor. Caulk pipes passing through floor with non-shrinking grout or approved caulking compound (Except DWV Piping penetrating a concrete slab set on finish grade), provide "Link-Seal" sleeve sealing system for concrete/slab penetrations which are below grade. Caulk/seal piping passing through fire rated building assembly with UL rated assemblies. Provide fire-rated assemblies per local AHJ requirements
 - c. Wall Sleeves: Provide sleeves on pipes passing through concrete or masonry construction. Provide sleeve flush with finished face of wall. Caulk pipes passing through walls with non-shrinking caulking compound. Provide modular link sealing system for concrete penetrations which are below grade. Caulk/seal piping passing through fire-rated assemblies per local AHJ requirements.
 - d. Beam Sleeves: Coordinate with trades for locations of pipe sleeves in reinforced concrete and steel beams. Indicate penetrations on structural shop drawings. See Drawings and Specifications for specific sleeve location limitations. Plumbing Drawings are diagrammatic. Offset piping as required to meet these limitations. Pipe sleeve locations must be indicated on reinforced concrete and steel beam shop drawings. Field cutting of beams not allowed without written approval of structural engineer. No extra costs allowed for failure to coordinate beam penetrations prior to reinforced concrete and steel beam shop drawing submittal.
 - 2. Installation of metallic or plastic piping penetrations through non fire-rated walls and partitions and through smoke-rated walls and partitions:
 - a. Install fabricated pipe sleeve.
 - b. After installation of sleeve and piping, tightly pack entire annular void between piping or piping insulation and sleeve identification.
 - c. Seal each end airtight with a resilient nonhardening seal per code.
 - 3. Piping penetrations through fire-rated (1 to 3 hour) assemblies:
 - a. Select and install pre-engineered pipe penetration system in accordance with UL listing and manufacturer's recommendation.
 - b. Provide proper sizing when providing sleeves or core-drilled holes to accommodate penetration. Firestop voids between sleeve or core-drilled hole and pipe passing through to meet requirements of ASTM E84.

- 3.2 SANITARY, DRAINAGE (RAIN/STORMWATER) DWV PIPING, BURIED WITHIN 5-FEET OF BUILDING
- A. Excavation and Backfill:
 - 1. See 3.01 above.
 - B. Drainage, Waste and Vent Piping: Test in accordance with governing plumbing code or as follows: Test drainage and venting systems, with necessary openings plugged, to permit system to be filled with water and subjected to water pressure of minimum of 5 PSI head. System to hold water without water level drop greater than 1/2 pipe diameter of largest nominal pipe size within 24-hour period. Test system in sections if minimum head cannot be maintained in each section. 5 PSI head to be minimum pressure at highest joint.
 - C. Corrosive Soil Conditions:
 - 1. Wrap steel, iron, copper or other metal piping materials/fittings with Protecto Wrap 200, 30 mils or greater. Maintain a 1/2-inch overlap and install per manufacturer's requirements.
 - 2. Provide epoxy coated cast iron pipe and fittings for drainage systems.
 - D. Cast-Iron Joints: Comply with coupling manufacturer's Cast Iron Soil Pipe Institute Standards and installation instructions.
 - E. Sanitary and Storm Drainage:
 - 1. Grade piping at a uniform pitch of 2 percent unless otherwise noted on Drawings.
 - 2. Indirect Waste or Drain Piping: Extend piping to discharge as shown on Drawings. Maintain minimum air gap. Provide traps on indirect waste or drain piping exceeding 60-inches.
 - 3. Fixture Carriers: Concealed fixture carriers for wall hung plumbing fixtures are specified in Section 22 40 00, Plumbing Fixtures.
 - 4. Drains:
 - a. Install drains to suit finished floor. Install drains and components per manufacturer's instructions. Slope flooring to floor drain or sink a minimum of 1/2-inch below finished floor elevation.
 - b. Install P-traps for hub drains, floor drains and floor sinks. P-traps to be of the same materials as soil and waste piping. Provide trap primer assembly for each drain or floor sink.
 - 5. Wall Access Panel: Secure to wall framing and install so that flange forms a close fitting joint with the finished wall surface.
 - 6. Heat trace and insulate P-traps exposed to freezing conditions. Provide heat trace and electronic components to Division 26 for installation.
 - 7. Insulate horizontal branch lines from floor sinks, receptors and drains receiving cold discharge from equipment and appliances.
 - F. Epoxy Coated Cast Iron Pipe and Fittings: Coat the piping terminus of any cut piping with an applied epoxy per manufacturer's instructions. Denso Protal 7200 fast-cure epoxy repair coating.

3.3 SANITARY, DRAINAGE (RAIN/STORMWATER) DWV PIPING, ABOVE GRADE

- A. Drainage, Waste and Vent Piping: Test in accordance with governing plumbing code or as follows: Test drainage and venting systems, with necessary openings plugged, to permit system to be filled with water and subjected to water pressure of minimum of 5 PSI head. System to hold water without water level drop greater than 1/2 pipe diameter of largest nominal pipe size within 24-hour period. Test system in sections if minimum head cannot be maintained in each section. 5 PSI head to be minimum pressure at highest joint.
- B. Firestopping Penetrations in Fire-Rated Wall/Floor Assemblies:
1. Provide proper sizing when providing sleeves or core-drilled holes to accommodate penetration. Firestop voids between sleeve or core-drilled hole and pipe passing through to meet requirements of ASTM E814.
- C. Solder copper tube and fitting joints with lead free nickel/silver bearing solder meeting ASTM Std. B-32, in accordance with IAPMO Is 3-93, ASTM B-828 and Copper Development Association recommended procedures. Clean joints by other than chemical means prior to assembly. "Shock" cooling is prohibited. Fluxes to be water soluble for copper and brass potable water applications, and meeting CDA standard test method 1.0 and ASTM B813-91. Apply solder until a full fillet is present around the joint. Do not apply solder and flux in such excessive quantities as to run down interior of pipe. Lead solder or corrosion flux not to be present at the jobsite.
- D. Cast-Iron Joints: Comply with coupling manufacturer's Cast Iron Soil Pipe Institute Standards and installation instructions.
- E. Sanitary and Storm Drainage:
1. Grade piping at a uniform pitch of 2 percent unless otherwise noted on Drawings.
 2. Indirect Waste or Drain Piping: Extend piping to discharge as shown on Drawings. Maintain minimum air gap. Provide traps on indirect waste or drain piping exceeding 60-inches.
 3. Fixture Carriers: Concealed fixture carriers for wall hung plumbing fixtures are specified in Section 22 40 00, Plumbing Fixtures.
 4. Drains:
 - a. Install drains to suit finished floor or roof surface. Install drains and components per manufacturer's instructions. Slope flooring to floor drain or sink a minimum of 1/2-inch below finished floor elevation.
 - b. Install P-traps for hub drains, floor drains and floor sinks. P-traps to be of the same materials as soil and waste piping. Provide trap primer assembly for each drain or floor sink.
 5. Wall Access Panel: Secure to wall framing and install so that flange forms a close fitting joint with the finished wall surface.
 6. Heat trace and insulate P-traps exposed to freezing conditions. Provide heat trace and electronic components to Division 26 for installation.
 7. Insulate horizontal branch lines from floor sinks, receptors and drains receiving cold discharge from equipment and appliances.

3.4 PUMP WASTE PRESSURE PIPING (PUMPED DISCHARGE)

- A. Excavation and Backfill:
1. See 3.01 above.
- B. Testing of Pressurized Systems:
1. Test each pressurized piping system at 150 percent of operating pressure indicated, but not less than 125 PSIG test pressure.
 2. Observe each test section for leakage at end of test period. Test fails if leakage is observed or if pressure drop exceeds 2 percent of test pressure.
- C. Firestopping Penetrations in Fire-Rated Wall/Floor Assemblies:
1. Provide proper sizing when providing sleeves or core-drilled holes to accommodate penetration. Firestop voids between sleeve or core-drilled hole and pipe passing through to meet requirements of ASTM E814.
- D. Braze copper tube and fitting socket with BCuP series filler metal without flux. Use listed brazing flux for joining of copper tube to brass or bronze fittings, meeting AWS FB3A or FB3C. "Shock" cooling is prohibited. A continuous fillet is to be visible around the completed joint. After cooling, thoroughly remove flux residue with warm water and a brush prior to testing. Do not use BCuP filler on copper alloys containing over 10 percent nickel. Cap or plug piping during construction to prevent entry of foreign material.
- E. Welders performing work under this Contract to be certified and qualified in accordance with tests prescribed by the National Certified Welding Bureau (NCWB) or by other approved test procedures using methodology and procedures covered in the ASME Boiler and Pressure Vessel Code, Section IX, "Qualification Standard for Welding and Brazing Procedures, Welders, Brazers, and Welding and Brazing Operators". Installation to conform to ANSI 31.1 "Power Piping".
1. Submit for approval the names, identification, and welder's assigned number, letter or symbol for welders assigned to this project.
 2. Use the assigned identification symbol to identify the work of each welder and indelibly stamp immediately upon completion of each weld.
 3. Welders to be tested and certified for all positions.
 4. Submit identifying stenciled test coupons made by each operator.
 5. Welders may be required to retake welding certification tests without additional expense.
 6. When so requested, a welder will not be permitted to work as a welder on this project until he has been recertified in accordance with NCWB.
 7. Recertification of the welder to be made after the welder has taken and passed the required tests.
- F. Weld pipe joints in accordance with recognized industry practice and as follows:
1. Weld pipe joints only when ambient temperature is above 0F.
 2. Bevel pipe ends at a 37.5 degree angle where possible, smooth rough cuts, and clean to remove slag, metal particles, and dirt.
 3. Use pipe clamps or tack-weld joints with 1-inch long welds, 4 welds for pipe sizes to 10-inches, 8 welds for pipe sizes 12-inches to 20-inches.
 4. Build up welds with a stringer-bead pass, followed by a hot pass, followed by a cover or filler pass. Eliminate valleys at center and at edges of each weld. Weld by procedures

which will ensure elimination of unsound or unfused metal, cracks, oxidation, blow-holes, and non-metallic inclusions.

5. Do not weld out piping system imperfections by tack-welding procedures. Re-fabricate to comply with requirements.
6. At Installer's option, install forged branch-connection fittings whenever branch pipe is indicated, or install a regular T-fitting.

3.5 WATER PIPING, BURIED WITHIN 5-FEET OF BUILDING

A. Excavation and Backfill:

1. See 3.01 above.

B. Water Piping: Eliminate air from system. Fill and test at 125 PSIG or minimum 1-1/2 times static pressure at connection to serving utility main for period of two hours with no loss in pressure.

C. Domestic Water:

1. "Piping" to include pipes, fittings, nipples, valves and accessories connected thereto.
2. Run piping generally parallel to the axis of the building, arranged to conform to the building requirements and to suit the necessities of clearance for other mechanical ducts, flues, conduits and work of other trades, and as close to ceiling or other construction as practical, free of unnecessary traps or bends.
3. Grade water supply piping for complete drainage of the system. Install hose bibbs at low points.
4. Use unions for piping connections to equipment.
5. Provide sufficient elbows, swings and offsets to permit free expansion and contraction.
6. Use reducers or increasers. Use no bushings.
7. Ream or file each pipe to remove burrs. Inspect each length of pipe and each fitting for workmanship and clear passageways.
8. Cover, cap or otherwise protect open ends of piping during construction to prevent damage to threads or flanges and prevent entry of foreign matter. Disinfect and sterilize water supply piping as specified. Furnish written report on final water quality results.
9. Install exposed connections to equipment with special care, showing no tool marks or threads at fittings and piping. No bowed or bent piping permitted.
10. Make ferrous to non-ferrous connections with dielectric fittings.
11. Use extra heavy pipe for nipples, where unthreaded portion is less than 1-1/2-inches. Use no close nipples. Use only shoulder-type nipples.
12. Through-Wall Pipes: Type 'L' copper tubing for through-wall pipes which connect to exposed stops at wall surface. Anchor the pipes in the wall; attach pipe with U-bolts to steel back-up plates or steel angles anchored in the wall. Provide wrought copper elbow which securely anchors ears in wall at through-wall pipes.
13. Provide drain valves at base of risers and at low points on the system.
14. Backflow Preventers: Pipe relief to nearest drain. Slope at 2 percent.

D. Sterilization of Domestic Water System:

1. General: Upon completion of tests and necessary replacements, thoroughly flush and disinfect domestic water piping.
2. Method: After thoroughly flushing system with water to remove sediment, fill system with a solution containing 50 parts per million of chlorine for not less than 24 hours or

- 200 parts per million of chlorine for not less than 3 hours. After retention, drain, reflush and return system to service.
 3. Certification: Provide copy of domestic water chlorination certificate in each operations and maintenance manual.
 4. Provide water line disinfections performed by a licensed contractor with training in potable water line disinfections.
- E. Buried Pre-Insulated Pipe Installation:
1. Installation and Testing: Install and test products in accordance with manufacturer's installation instructions.
 2. Manufacturer's installation instructions are to describe the following:
 - a. Storage and handling of pipes.
 - b. Trench preparation.
 - c. Installing pipe.
 - d. Installing accessories.
 - e. Installing fittings.
 - f. Building penetrations.
 - g. Field insulation kits.
 - h. Testing.

3.6 HOT AND COLD DOMESTIC WATER ABOVE GRADE

- A. Water Piping: Eliminate air from system. Fill and test at 125 PSIG or minimum 1-1/2 times static pressure at connection to serving utility main for period of two hours with no loss in pressure.
- B. Testing of Pressurized Systems:
1. Test each pressurized piping system at 150 percent of operating pressure indicated, but not less than 125 PSIG test pressure.
 2. Observe each test section for leakage at end of test period. Test fails if leakage is observed or if pressure drop exceeds 2 percent of test pressure.
- C. Test hot and cold domestic water piping systems upon completion of rough-in and before connection to fixtures at hydrostatic pressure of 125 PSIG.
- D. Firestopping Penetrations in Fire-Rated Wall/Floor Assemblies:
1. Provide proper sizing when providing sleeves or core-drilled holes to accommodate penetration. Firestop voids between sleeve or core-drilled hole and pipe passing through to meet requirements of ASTM E814.
- E. Solder copper tube and fitting joints with lead free nickel/silver bearing solder meeting ASTM Std. B-32, in accordance with IAPMO Is 3-93, ASTM B-828 and Copper Development Association recommended procedures. Clean joints by other than chemical means prior to assembly. "Shock" cooling is prohibited. Fluxes to be water soluble for copper and brass potable water applications, and meeting CDA standard test method 1.0 and ASTM B813-91. Apply solder until a full fillet is present around the joint. Do not apply solder and flux in such excessive quantities as to run down interior of pipe. Lead solder or corrosion flux not to be present at the jobsite.

- F. Braze copper tube and fitting socket with BCuP series filler metal without flux. Use listed brazing flux for joining of copper tube to brass or bronze fittings, meeting AWS FB3A or FB3C. "Shock" cooling is prohibited. A continuous fillet is to be visible around the completed joint. After cooling, thoroughly remove flux residue with warm water and a brush prior to testing. Do not use BCuP filler on copper alloys containing over 10 percent nickel. Cap or plug piping during construction to prevent entry of foreign material.
- G. Domestic Water:
1. "Piping" to include pipes, fittings, nipples, valves and accessories connected thereto.
 2. Run piping generally parallel to the axis of the building, arranged to conform to the building requirements and to suit the necessities of clearance for other mechanical ducts, flues, conduits and work of other trades, and as close to ceiling or other construction as practical, free of unnecessary traps or bends.
 3. Grade water supply piping for complete drainage of the system. Install hose bibbs at low points.
 4. Use unions for piping connections to equipment.
 5. Provide sufficient elbows, swings and offsets to permit free expansion and contraction.
 6. Use reducers or increasers. Use no bushings.
 7. Ream or file each pipe to remove burrs. Inspect each length of pipe and each fitting for workmanship and clear passageways.
 8. Cover, cap or otherwise protect open ends of piping during construction to prevent damage to threads or flanges and prevent entry of foreign matter. Disinfect and sterilize water supply piping as specified. Furnish written report on final water quality results.
 9. Install exposed connections to equipment with special care, showing no tool marks or threads at fittings and piping. No bowed or bent piping permitted.
 10. Make ferrous to non-ferrous connections with dielectric fittings.
 11. Use extra heavy pipe for nipples, where unthreaded portion is less than 1-1/2-inches. Use no close nipples. Use only shoulder-type nipples.
 12. Through-Wall Pipes: Type 'L' copper tubing for through-wall pipes which connect to exposed stops at wall surface. Anchor the pipes in the wall; attach pipe with U-bolts to steel back-up plates or steel angles anchored in the wall. Provide wrought copper elbow which securely anchors ears in wall at through-wall pipes.
 13. Provide drain valves at base of risers and at low points on the system.
 14. Backflow Preventers: Pipe relief to nearest drain. Slope at 2 percent.
- H. Sterilization of Domestic Water System:
1. General: Upon completion of tests and necessary replacements, thoroughly flush and disinfect domestic water piping.
 2. Method: After thoroughly flushing system with water to remove sediment, fill system with a solution containing 50 parts per million of chlorine for not less than 24 hours or 200 parts per million of chlorine for not less than 3 hours. After retention, drain, reflush and return system to service.
 3. Certification: Provide copy of domestic water chlorination certificate in each operations and maintenance manual.
 4. Provide water line disinfections performed by a licensed contractor with training in potable water line disinfections.

3.7 CONDENSATE PIPING

- A. Firestopping Penetrations in Fire-Rated Wall/Floor Assemblies:
 - 1. Provide proper sizing when providing sleeves or core-drilled holes to accommodate penetration. Firestop voids between sleeve or core-drilled hole and pipe passing through to meet requirements of ASTM E814.

3.8 PRIMER PIPING

- A. Excavation and Backfill:
 - 1. See 3.01 above.
- B. Testing:
 - 1. See 3.01 above.

3.9 CLEANOUTS

- A. Install in aboveground piping and building drain piping as indicated, as required by code; at each change in direction of piping greater than 135 degrees; at minimum intervals of 100-feet; and at base of each vertical soil or waste stack. Install floor and wall cleanout covers for concealed piping. Select type to match adjacent building finish. Provide shop drawings to Architect to coordinate locations and types of cleanouts with Architect prior to installation.
- B. Drainage, Waste and Vent Piping: Test in accordance with governing plumbing code or as follows: Test drainage and venting systems, with necessary openings plugged, to permit system to be filled with water and subjected to water pressure of minimum of 5 PSI head. System to hold water without water level drop greater than 1/2 pipe diameter of largest nominal pipe size within 24-hour period. Test system in sections if minimum head cannot be maintained in each section. 5 PSI head to be minimum pressure at highest joint.
- C. Corrosive Soil Conditions:
 - 1. Wrap steel, iron, copper or other metal piping materials/fittings with Protecto Wrap 200, 30 mils or greater. Maintain a 1/2-inch overlap and install per manufacturer's requirements.
 - 2. Provide epoxy coated cast iron pipe and fittings for drainage systems.
- D. Cast-Iron Joints: Comply with coupling manufacturer's Cast Iron Soil Pipe Institute Standards and installation instructions.

END OF SECTION

SECTION 22 3000 - PLUMBING EQUIPMENT

PART 1 - GENERAL

1.1 SUMMARY

- A. Work Included:
 - 1. Elevator Simplex Sump Pump System
 - 2. Garbage Disposal

1.2 RELATED SECTIONS

- A. Contents of Division 22, Plumbing and Division 01, General Requirements apply to this Section.

1.3 REFERENCES AND STANDARDS

- A. References and Standards as required by Section 22 00 00, Plumbing Basic Requirements and Division 01, General Requirements.

1.4 SUBMITTALS

- A. Submittals as required by Section 22 00 00, Plumbing Basic Requirements and Division 01, General Requirements.

1.5 QUALITY ASSURANCE

- A. Quality assurance as required by Section 22 00 00, Plumbing Basic Requirements and Division 01, General Requirements.
- B. In addition, meet the following:
 - 1. NSF 61, Annex G compliant.
 - 2. ISO 9001 Certified.
 - 3. IAPMO Low Lead Certification
- C. Products approved for installation by state authorizing agency, no exceptions.

1.6 WARRANTY

- A. Warranty of materials and workmanship as required by Section 22 00 00, Plumbing Basic Requirements and Division 01, General Requirements.

PART 2 - PRODUCTS

2.1 MANUFACTURERS

- A. Elevator Simplex Sump Pump System - Oil Filled:
 - 1. Bell and Gossett switch.
 - 2. Weil
 - 3. Goulds
 - 4. Hydromatic

5. Liberty
6. Zoeller
7. Or approved equivalent.

B. Garbage Disposal:

1. In-Sink-Erator
2. Salvajor
3. Hobart
4. Waste King
5. Or approved equivalent.

2.2 GENERAL

- A. Reference drawings for capacities and specific model numbers.

2.3 ELEVATOR SIMPLEX SUMP PUMP SYSTEM

- A. System: Sanitary Sewer.
- B. Entire unit is to be delivered complete with operating controls and require only plumbing and electrical service connections.
- C. Provide submersible sump pump with 2-inch I.P.S. discharge, bronze fitted construction with submersible sealed motor, stainless steel shaft, bronze impeller, mechanical seal, waterproof 20-foot power cord and fully submersible float switch for mounting on pump discharge pipe.
- D. Provide check valve and shut-off valve on discharge side of pump.
- E. Provide perforated steel basin cover for sump in elevator pit.

2.4 GARBAGE DISPOSAL

A. Residential Duty:

1. General: Complete food waste disposal to include a stainless steel sink flange adapter assembly to match fixture. Dishwasher connection. Stainless steel or galvanized grind chamber, shredder ring, and two 360 degree swivel impellers/lugs. Continuous feed.
2. Single phase, permanently lubricated motor with manual reset, corrosion protection shield, and sound absorbing upper shell. UL listed.
3. Warranty: 2 year parts and in-home service.

B. Commercial Light Duty:

1. General: Complete food waste disposal to include a stainless steel sink flange adapter assembly to match fixture. Stainless steel grind chamber, shredder ring, and two 360° swivel impellers. Continuous feed, automatic
2. Stainless steel grind chamber, shredder ring, and two 360° swivel impellers. Continuous feed, automatic.
3. Reversing split-phase motor, corrosion protection shield, and sound absorbing upper shell. UL listed.
4. Warranty: Commercial 1 year parts and service.

- C. Commercial Heavy Duty:
 - 1. General: Complete food waste disposal to include a stainless steel sink flange adapter assembly to match fixture. Stainless steel grind chamber, shredder ring, and two 360° swivel impellers. Continuous feed, automatic.
 - 2. Reversing split-phase motor, corrosion protection shield, and sound absorbing upper shell. UL listed.
 - 3. Controller: Stainless steel, NEMA 4, auto-reversing with automatic drop out (in case of power loss). Disconnect switch, post water flush, timed or continuous run
 - 4. Warranty: commercial 1 year parts and service.

PART 3 - EXECUTION

3.1 GENERAL

- A. Examine areas and conditions under which equipment is to be installed. Do not proceed with work until unsatisfactory conditions have been corrected.
- B. Install equipment in accordance with manufacturer's installation instructions. Install units plumb and level, firmly anchored in locations indicated, and maintain manufacturer's recommended clearances.
- C. Orients so controls and devices needing service and maintenance have adequate access.
- D. Certificates: Submit appropriate Certificates of Shop Inspection and Data Report as required by provisions of ASME Boiler and Pressure Vessel Code.
- E. Connect water piping to units with shutoff valves and unions.
- F. Equipment Rigging: Heavy duty rigging eye bolts for Crosby Group swivel hoist rings installed over pump access covers for removal or maintenance.
- G. Equipment Start-Up:
 - 1. Start-up, test, and adjust equipment in accordance with manufacturer's start-up instructions. Check and calibrate controls.
 - 2. Start-up performed by authorized manufacturer's representative or agent. Provide credentials of start-up personnel to Architect and Owner's Authorized Representative for approval.
 - 3. Remove and replace filters when start-up testing is executed.
 - 4. Manufacturer adjusts operating parameters of equipment to compensate to elevation of 500-feet above sea level.
 - 5. Architect, Commissioning Agent, and Owner's Authorized Representative will be notified 10 days prior to start-up and will be present at start-ups.
 - 6. Provide written report from manufacturer's representative on results of start-up within 48 hours.
 - 7. Technical Training of maintenance staff includes two hours minimum per each piece of equipment.
 - 8. Seismic Verification:

- a. Contractor will retain structural engineer who will submit stamped and signed anchoring and restraint details on plumbing equipment with submittal data in accordance with Division 22, Plumbing requirements.
- b. Contractor's Structural Engineer will test and verify in writing that seismic restraints have been installed in accordance with their details.

3.2 ELEVATOR SIMPLEX SUMP PUMP SYSTEM

- A. Examine areas and conditions under which equipment is to be installed. Do not proceed with work until unsatisfactory conditions have been corrected.
- B. Install equipment in accordance with manufacturer's installation instructions. Install units plumb and level, firmly anchored in locations indicated, and maintain manufacturer's recommended clearances.
- C. Orients so controls and devices needing service and maintenance have adequate access.
- D. Certificates: Submit appropriate Certificates of Shop Inspection and Data Report as required by provisions of ASME Boiler and Pressure Vessel Code.
- E. Connect piping to units with shutoff valves, check valves and unions.

3.3 GARBAGE DISPOSAL

- A. Examine areas and conditions under which equipment is to be installed. Do not proceed with work until unsatisfactory conditions have been corrected.
- B. Install complete food waste disposal system including water, waste connections, and electrical connection, including associated control devices. Install equipment in accordance with manufacturer's installation instructions. Install units plumb and level, firmly anchored in locations indicated, and maintain manufacturer's recommended clearances. Set devices and adjust any support or mounting assemblies per manufacturer's recommendations.
- C. Water supplies, as applicable are to be provided with shut-off valves, solenoid valves, backflow preventers and water hammer arrestors.
- D. Coordinate power requirements and connection methods with Division 26.
- E. Equipment Start-Up:
 1. Start-up, test, and adjust equipment in accordance with manufacturer's start-up instructions. Check and calibrate controls.
 2. Start-up performed by authorized manufacturer's representative or agent. Provide credentials of start-up personnel to Architect and Owner's Authorized Representative for approval.

END OF SECTION

SECTION 22 4000 - PLUMBING FIXTURES

PART 1 - GENERAL

1.1 SUMMARY

- A. Work Included:
 - 1. General Plumbing Fixtures:
 - a. China Fixtures, White Only
 - b. Enameled Steel Fixtures, White Only
 - c. Faucet Fittings
 - d. Fiberglass Fixtures, White Only
 - e. Hose Reels
 - f. Molded Resin or Stone Fixtures
 - g. Shower Valves
 - h. Stainless Steel Fixtures
 - i. Thermostatic Mixing Valves
 - j. Wash Fountains
 - 2. Carriers
 - 3. Catch Basins
 - 4. Downspout Boot/Nozzle/Cover
 - 5. Fixture Trim
 - 6. Floor Drains
 - 7. Flushometers - Water Closet/Urinal
 - 8. Hose Bibbs
 - 9. Kitchen Equipment
 - 10. Water Closet Seats
 - 11. Drain Boxes
 - 12. Water Supply Boxes

1.2 RELATED SECTIONS

- A. Contents of Division 22, Plumbing and Division 01, General Requirements apply to this Section.

1.3 REFERENCES AND STANDARDS

- A. References and Standards as required by Section 22 00 00, Plumbing Basic Requirements and Division 01, General Requirements.

1.4 SUBMITTALS

- A. Submittals as required by Section 22 00 00, Plumbing Basic Requirements and Division 01, General Requirements.

1.5 QUALITY ASSURANCE

- A. Quality assurance as required by Section 22 00 00, Plumbing Basic Requirements and Division 01, General Requirements.

- B. In addition, meet the following:
1. Comply with lead free (less than or equal to 0.25 percent) products in drinking water systems.
 2. NSF 61, Annex G, Drinking Water System Components, Compliant.
 3. ISO 9001, Quality Management Standard Certified.
 4. IAPMO Low Lead Certification.
 5. Provide fixtures, faucets and accessories to meet barrier free requirements of the governing code with respect to plumbing fixtures provided for the physically handicapped.

1.6 WARRANTY

- A. Warranty of materials and workmanship as required by Section 22 00 00, Plumbing Basic Requirements and Division 01, General Requirements.

PART 2 - PRODUCTS

2.1 MANUFACTURERS

- A. "Or approved equivalent" as defined in 22 00 00, Plumbing Basic Requirements. Substitution process requirements apply to approved equivalent products.
- B. General Plumbing Fixtures: See Schedule on Drawings for type.
1. China Fixtures - White Only:
 - a. American Standard
 - b. Briggs
 - c. Crane
 - d. Eljer
 - e. Kohler
 - f. Universal-Rundle
 - g. Or approved equivalent.
 2. Enameled Steel Fixtures - White Only:
 - a. American Standard
 - b. Briggs
 - c. Crane
 - d. Eljer
 - e. Kohler
 - f. Universal-Rundle
 - g. Or approved equivalent.
 3. Faucet Fittings:
 - a. Private:
 - 1) Chicago
 - 2) Delta Commercial
 - 3) Moen
 - 4) Speakman
 - 5) Symmons
 - 6) T&S Brass
 - 7) Or approved equivalent.
 - b. Public:

- 1) American Standard
 - 2) Chicago
 - 3) Delta Commercial
 - 4) Moen Commercial
 - 5) Sloan
 - 6) Symmons
 - 7) T & S Brass
 - 8) Or approved equivalent.
4. Fiberglass Fixtures - White Only:
 - a. Aqua-Glass
 - b. Briggs
 - c. Crane
 - d. Comfort Designs
 - e. Florestone
 - f. Hytec
 - g. Mustee
 - h. Universal-Rundle
 - i. Or approved equivalent.
 5. Hose Reels:
 - a. Balcrank
 - b. Reelcraft
 - c. Lincoln
 - d. Or approved equivalent.
 6. Molded Resin or Stone Fixtures:
 - a. Fiat
 - b. Mustee
 - c. Stern Williams
 - d. Or approved equivalent.
 7. Shower Valves:
 - a. Acorn
 - b. Chicago
 - c. Delta
 - d. Moen
 - e. Powers
 - f. Symmons
 - g. Or approved equivalent.
 8. Stainless Steel Fixtures:
 - a. Elkay
 - b. Haws
 - c. Just
 - d. Or approved equivalent.
 9. Thermostatic Mixing Valves:
 - a. Bradley
 - b. Powers
 - c. Symmons
 - d. Holby
 - e. Or approved equivalent.
 10. Wash Fountains:
 - a. Acorn

- b. Bradley
 - c. Or approved equivalent.

- C. Carriers:
 - 1. JR Smith
 - 2. Zurn
 - 3. Or approved equivalent.

- D. Catch Basins:
 - 1. Lynch
 - 2. Or approved equivalent.

- E. Downspout Boot/Nozzle/Cover:
 - 1. JR Smith
 - 2. Mifab
 - 3. Sioux Chief
 - 4. Zurn
 - 5. Or approved equivalent.

- F. Fixture Trim:
 - 1. McGuire
 - 2. Dearborn Brass
 - 3. Oatey
 - 4. Or approved equivalent.

- G. Floor Drains:
 - 1. Mifab
 - 2. Sioux Chief
 - 3. Smith
 - 4. Wade
 - 5. Watts
 - 6. Zurn

- H. Flushometers - Water Closet/Urinal:
 - 1. Delaney
 - 2. Sloan
 - 3. Zurn
 - 4. Or approved equivalent.

- I. Hose Bibbs:
 - 1. Chicago
 - 2. JR Smith
 - 3. Mifab
 - 4. Wade
 - 5. Woodford
 - 6. Zurn
 - 7. Or approved equivalent.

- J. Kitchen Equipment:

1. No products specified. See Part 3 "Kitchen Equipment" article below for additional information.
- K. Water Closet Seats:
1. Bemis
 2. Or approved equivalent.
- L. Drain Boxes:
1. Sioux Chief
 2. Or approved equivalent.
- M. Water Supply Boxes:
1. Sioux Chief
 2. Or approved equivalent.

2.2 GENERAL PLUMBING FIXTURES

- A. Review substitution request requirements in Division 01, General Requirements and 22 00 00, Plumbing General Requirements.
- B. Reference Architectural Details for mounting height and location of fixtures.
- C. Provide factory fabricated fixtures of type, style and material indicated on the plumbing fixture connection schedule shown on the Drawings. For each type fixture, provide fixture manufacturer's standard trim, carrier, seats, and valves as indicated by their published product information; either as designed and constructed, or as recommended by manufacturer, or required for complete installation. Where more than one type is indicated, selection is installer's option; but, fixtures of same type must be furnished by a single manufacturer. Where type is not otherwise indicated, provide fixtures complying with governing regulations.
- D. Provide fixtures complete with fittings, supports, fastening devices, bolt caps, faucets, valves, traps, stops and appurtenances.
- E. Plumbing Fixture Thermostatic Mixing Valves:
1. Lavatories provide ASSE 1070 compliant mixing valves or multiple lavatories served by a single ASSE 1070 compliant mixing valve.
 2. Sinks serviced with a single ASSE 1070 mixing valve or multiple sinks served by a single ASSE 1070 mixing valve.
 3. Commercial kitchen handsinks provide ASSE 1070 mixing valves.
 4. Janitor sinks or process/maintenance type sinks do not require ASSE 1070 mixing valves if operated by trained personnel. Provide signage per Section 22 05 53, Identification for Plumbing Piping and Equipment.
 5. Hot water hose bibbs do not require ASSE 1070 mixing valves if operated by trained personnel. Provide signage per Section 22 05 53, Identification for Plumbing Piping and Equipment.

2.3 CARRIERS

- A. Wall Hung Water Closets:

1. Vertical: Zurn Z-1204-N4-XH-50 or Z-1204-ND4-XH-50 (JR Smith 230y-MS4-M12/230DY-M54-M12). Adjustable vertical load siphon jet with 300 lb. capacity.
 2. Horizontal: Zurn ZE-1203-N4-XH-50 or ZE-1203-ND4-XH-50 (JR Smith 220 R/L-Y-M54-M12/220DY-M5-M12). Adjustable horizontal siphon jet with 300 lb. load capacity.
- B. Wall Hung Urinal: Zurn Z-1218-WS. (JR Smith 637). Coupling type or plate type with bearing plate 200 lb. capacity.
- C. Wall Hung Lavatory: Zurn Z-1231 (D). (JR Smith 700). Concealed arm or Plate type, 250 lb. capacity.
- D. Wall Hung Service Sink: Zurn Z-1218. (JR Smith 913/914). Coupling type. 300 lb. capacity.
- E. Wall Hung Drinking Fountain: Zurn Z-1225-BL (JR Smith 834-97-98). Plate type. 300 lb. capacity.
- F. Wall Hung Flushing Rim Clinic Sink: Zurn Z-1217 (JR Smith 0915-Y4-98). Coupling Type. 300 lb. capacity.
- G. 750 lb. Carrier for Water Closet:
1. Adjustable vertical type.
 2. Adjustable horizontal type.
- 2.4 CATCH BASINS
- A. See Schedule on Drawings for type.
- 2.5 DOWNSPOUT BOOT/NOZZLE/COVER
- A. See Schedule on Drawings for type.
- 2.6 FIXTURE TRIM
- A. Traps: Provide heavy duty commercial grade traps on fixtures except fixtures with integral traps. Exposed traps will be chromium plated cast brass or 17 gauge chromium plated brass tubing.
1. Sink: McGuire 8912-C-DF.
 2. Lavatory: McGuire 8902-C-DF.
- B. Supplies and Stops: Lead free heavy duty commercial grade, chrome plated with brass stems. Stops: T-handle or Loose Key type.
1. Lavatory: McGuire LFH 2165 CK
 2. Sink: McGuire LFH 2167 LK
 3. Water Closets: McGuire
- C. Lavatory Grid Strainer: McGuire 155A.
- D. Sink Grid Strainer: McGuire 152N.

- E. Shower Grid Strainer: McGuire 1266.
- F. Sink Basket Strainer: McGuire 151.
- G. Trim barrier-free wrap for P-traps and supplies by McGuire, Pro-Wrap, Plumberex or True-bro.
- H. Escutcheons: McGuire wrought brass deep bell.
- I. Wax Rings and Toilet Bolts: WM Harvey No Seep No. 1 053065-N.

2.7 FLOOR DRAINS

- A. See Schedule on Drawings for types.

2.8 FLUSHOMETERS - WATER CLOSET/URINAL

- A. See Schedule on Drawings for types.

2.9 HOSE BIBBS

- A. See Schedule on Drawings for types.

2.10 KITCHEN EQUIPMENT

- A. No products specified. See Part 3 "Kitchen Equipment" article below for additional information.

2.11 WATER CLOSET SEATS

- A. See Schedule on Drawings for type.

2.12 DRAIN BOXES

- A. See Schedule on Drawings for Type.
- B. Provide fire rated ASTM E-84 rated boxes where required by building construction.

2.13 WATER SUPPLY BOXES

- A. See Schedule on Drawings for Type.
- B. Provide fire rated ASTM E-84 rated boxes where required by building construction.

PART 3 - EXECUTION

3.1 GENERAL PLUMBING FIXTURE INSTALLATION INFORMATION

- A. Verification of Conditions:
 - 1. Examine rough-in work of water supply and waste piping systems to verify actual locations of piping connections prior to installing fixtures. Examine floors and substrates, and conditions under which fixture work is to be accomplished. Correct any incorrect

- locations of piping and other unsatisfactory conditions for installation of plumbing fixtures.
2. Examine walls, floors and cabinets for suitable conditions where fixtures are to be installed.
 3. Install plumbing fixtures level and plumb, in accordance with fixture manufacturer's written instructions, rough-in drawings and pertinent codes and regulations, design and referenced standards.
 4. Fasten plumbing fixtures securely to supports or building structure. Secure supplies behind or within wall construction to provide rigid installation.
 5. Install a stop valve in a readily accessible location in water connection to each fixture.
 6. Install escutcheons at each wall, floor and ceiling penetration in exposed finished locations and within cabinets and millwork.
 7. Seal fixtures to walls and floors using silicone sealant Dow Corning No. 780 or approved equivalent. Match sealant color to fixture color.
 8. Test fixtures to demonstrate proper operation upon completion of installation and after units are water pressurized. Replace malfunctioning units, then retest.
 9. Inspect each unit for damage prior to installation. Replace damaged fixtures.
 10. Replace washers or cartridges of leaking or dripping faucets and stops.
 11. Clean fixtures, trim and strainers using manufacturer's recommended cleaning methods and materials.
 12. During construction, cover installed fixtures, drains, sinks and water coolers with cardboard and wrap with sheet plastic.
 13. Provide trap primers for floor drains, floor sinks, trench drains and hub drains.
 14. Install roof and overflow roof drains per architectural details. Cover drains during roof construction to protect drain. Provide offsets or expansion joints at each roof/overflow drain.
 15. Do not use lead flashing.
- B. Owner Furnished Equipment:
1. Rough-in and make final connections to Owner furnished equipment. Provide necessary items to complete installation.
 2. Comply with requirements of this Section and Drawings for installation procedures.
- C. Adjusting and Cleaning: Clean plumbing fixtures, trim, and strainers of dirt and debris upon completion of installation. Adjust water pressure at drinking fountains, faucets, shower valves and flush valves to provide proper flow stream and specified GPM. Repair leaks at faucets and stops.
- D. Extra Stock: Furnish special wrenches and other devices necessary for servicing plumbing fixtures and trim to Owner.
- E. Field Quality Control: Upon completion of installation of plumbing fixtures, test fixtures to demonstrate capability and compliance with Specifications. Correct or replace malfunctioning units at site, then retest to demonstrate compliance.
- F. Protection: Protect fixtures and equipment from damage. Cover finished fixtures with cardboard and sheet plastic. Fixtures are not to be used during construction. Replace damaged items with new.

- G. Signage: For fixtures that do not have ASSE 1070 mixing valve protection for hot water temperature, provide signage per Section 22 05 53, Identification for Plumbing Piping and Equipment.

3.2 CARRIERS INSTALLATION

- A. Install components in accordance with manufacturer's instructions and approved product data submittals.
- B. Set plumb, level and rigid.
- C. Coordinate wall thickness so carrier has adequate depth to be concealed.

3.3 CATCH BASINS INSTALLATION

- A. Install components in accordance with manufacturer's instructions and approved product data submittals.
- B. Set plumb and level.
- C. Backfill with 3/4-inch crushed rock and compact.

3.4 DOWNSPOUT BOOT/NOZZLE/COVER INSTALLATION

- A. Install components in accordance with manufacturer's instructions and approved product data submittals.
- B. Set plumb, level and rigid.

3.5 FIXTURE TRIM INSTALLATION

- A. Install components in accordance with manufacturer's instructions and approved product data submittals.
- B. Set plumb, level and rigid.

3.6 FLOOR DRAINS INSTALLATION

- A. Install components in accordance with manufacturer's instructions and approved product data submittals.
- B. Set plumb, level and rigid.

3.7 FLUSHOMETERS - WATER CLOSET/URINAL INSTALLATION

- A. Install components in accordance with manufacturer's instructions and approved product data submittals.
- B. Set plumb, level and rigid.

3.8 HOSE BIBB INSTALLATION

- A. Install components in accordance with manufacturer's instructions and approved product data submittals.
- B. Set plumb, level and rigid.

3.9 KITCHEN EQUIPMENT INSTALLATION

- A. Install components in accordance with manufacturer's instructions and approved product data submittals.
- B. Furnish and install shutoff valves, pressure regulators, shock arrestors, vacuum breakers, strainers, indirect waste piping, backflow preventers, and other devices or piping which are not furnished with kitchen equipment or shown on Drawings.
- C. Set plumb, level and rigid.

3.10 WATER CLOSET SEAT INSTALLATION

- A. Install components in accordance with manufacturer's instructions and approved product data submittals.
- B. Set plumb, level and rigid.

3.11 DRAIN BOX INSTALLATION

- A. Install components in accordance with manufacturer's instructions and approved product data submittals.
- B. Set plumb, level and rigid.

3.12 WATER SUPPLY BOX INSTALLATION

- A. Install components in accordance with manufacturer's instructions and approved product data submittals.
- B. Set plumb, level and rigid.

END OF SECTION

SECTION 23 0000 - HEATING, VENTILATING AND AIR CONDITIONING (HVAC) BASIC REQUIREMENTS

PART 1 - GENERAL

1.1 SECTION INCLUDES

- A. Work included in 23 00 00, HVAC Basic Requirements applies to Division 23, HVAC work to provide materials, labor, tools, permits, incidentals, and other services to provide and make ready for Owner's use of heating, ventilating and air conditioning systems for proposed project.
- B. Contract Documents include, but are not limited to, Specifications including Division 00, Procurement and Contracting Requirements and Division 01, General Requirements, Drawings, Addenda, Owner/Architect Agreement, and Owner/Contractor Agreement. Confirm requirements before commencement of work.
- C. Definitions:
 - 1. Provide: To furnish and install, complete and ready for intended use.
 - 2. Furnish: Supply and deliver to project site, ready for unpacking, assembly and installation.
 - 3. Install: Includes unloading, unpacking, assembling, erecting, installation, applying, finishing, protecting, cleaning and similar operations at project site as required to complete items of work provided.
 - 4. Approved or Approved Equivalent: To possess the same performance qualities and characteristics and fulfill the utilitarian function without any decrease in quality, durability or longevity. For equipment/products defined by the Contractor as "equivalent", substitution requests must be submitted to Engineer for consideration, in accordance with Division 01, General Requirements, and approved by the Engineer prior to submitting bids for substituted items.
 - 5. Authority Having Jurisdiction (AHJ): Indicates reviewing authorities, including local fire marshal, Owner's insurance underwriter, Owner's Authorized Representative, and other reviewing entity whose approval is required to obtain systems acceptance.

1.2 RELATED SECTIONS

- A. Contents of Section applies to Division 23, HVAC Contract Documents.
- B. Related Work:
 - 1. Additional conditions apply to this Division including, but not limited to:
 - a. Specifications including Division 00, Procurement and Contracting Requirements and Division 01, General Requirements.
 - b. Drawings
 - c. Addenda
 - d. Owner/Architect Agreement
 - e. Owner/Contractor Agreement
 - f. Codes, Standards, Public Ordinances and Permits

1.3 REFERENCES AND STANDARDS

- A. References and Standards per Division 01, General Requirements, individual Division 23, HVAC Sections and those listed in this Section.
- B. Codes to include latest adopted editions, including current amendments, supplements and local jurisdiction requirements in effect as of the date of the Contract Documents, of/from:
1. State of Virginia:
 - a. 2012 International Building Code (IBC) with corresponding Virginia Construction Code Supplement
 - b. 2012 International Mechanical Code (IMC) with corresponding Virginia Construction Code Supplement
 - c. 2012 International Plumbing Code (IPC) with corresponding Virginia Construction Code Supplement
 - d. 2012 International Fuel Gas Code (IFGC) with corresponding Virginia Construction Code Supplement
 - e. 2012 National Electric Code (NFPA 70-2011) with corresponding Virginia Construction Code Supplement
 - f. 2012 International Energy Conservation Code (IECC) with corresponding Virginia Construction Code Supplement
- C. Reference standards and guidelines include but are not limited to the latest adopted editions from:
1. ABA - Architectural Barriers Act
 2. ABMA - American Bearing Manufacturers Association
 3. ADA - Americans with Disabilities Act
 4. AHRI - Air-Conditioning Heating & Refrigeration Institute
 5. AMCA - Air Movement and Control Association
 6. ANSI - American National Standards Institute
 7. ASCE - American Society of Civil Engineers
 8. ASHRAE - American Society of Heating, Refrigeration and Air-Conditioning Engineers
 9. ASHRAE Guideline 0, The Commissioning Process
 10. ASME - American Society of Mechanical Engineers
 11. ASPE - American Society of Plumbing Engineers
 12. ASSE - American Society of Sanitary Engineering
 13. ASTM - ASTM International
 14. AWWA - American Water Works Association
 15. CFR - Code of Federal Regulations
 16. CGA - Compressed Gas Association
 17. CISPI - Cast Iron Soil Pipe Institute
 18. EPA - Environmental Protection Agency
 19. ETL - Electrical Testing Laboratories
 20. FM - FM Global
 21. GAMA - Gas Appliance Manufacturers Association
 22. HI - Hydraulic Institute Standards
 23. IAPMO - International Association of Plumbing & Mechanical Officials
 24. IFGC - International Fuel Gas Code
 25. ISO - International Organization for Standardization

26. MSS - Manufacturers Standardization Society
27. NEC - National Electric Code
28. NEMA - National Electrical Manufactures Association
29. NFPA - National Fire Protection Association
30. NFGC - National Fuel Gas Code
31. NRCA - National Roofing Contractors Association
32. NSF - National Sanitation Foundation
33. OSHA - Occupational Safety and Health Administration
34. SMACNA - Sheet Metal and Air Conditioning Contractors' National Association, Inc.
35. TEMA - Tubular Exchanger Manufactures Association
36. TIMA - Thermal Insulation Manufactures Association
37. UL - Underwriters Laboratories, Inc.

D. See Division 23, HVAC individual Sections for additional references.

1.4 SUBMITTALS

- A. See Division 01, General Requirements for Submittal Procedures as well as specific individual Division 23, HVAC Sections.
- B. Provide drawings in format and software release equal to the design documents. Drawings to be the same sheet size and scale as the Contract Documents.
- C. In addition:
 1. "No Exception Taken" constitutes that review is for general conformance with the design concept expressed in the Contract Documents for the limited purpose of checking for conformance with information given. Any action is subject to the requirements of the Contract Documents. Contractor is responsible for the dimensions and quantity and will confirm and correlate at the job site, fabrication processes and techniques of construction, coordination of the work with that of all other trades, and the satisfactory performance of the work.
 2. Provide product submittals and shop drawings in electronic format only. Electronic format must be submitted via zip file via e-mail. For electronic format, provide one file per division containing one bookmarked PDF file with each bookmark corresponding to each Specification Section. Arrange bookmarks in ascending order of Specification Section number. Individual submittals sent piecemeal in a per Specification Section method will be returned without review or comment. All transmissions/submissions to be submitted to Architect. At Contractor's option, four separate submittals may be provided, consisting of long lead items, underground/site work, building work, and building automation system. Deviations will be returned without review.
 3. Product Data: Provide Manufacturer's descriptive literature for products specified in Division 23, HVAC Sections.
 4. Identify/mark each submittal in detail. Note what differences, if any, exist between the submitted item and the specified item. Failure to identify the differences will be considered cause for disapproval. If differences are not identified and/or not discovered during the submittal review process, Contractor remains responsible for providing equipment and materials that meet the Specifications and Drawings.
 - a. Label submittal to match numbering/references as shown in Contract Documents. Highlight and label applicable information to individual equipment or cross out/remove extraneous data not applicable to submitted model. Clearly note

- options and accessories to be provided, including field installed items. Highlight connections by/to other trades.
- b. Include technical data, installation instructions and dimensioned drawings for products, fixtures, equipment and devices installed, furnished or provided. Reference individual Division 23, HVAC Specification Sections for specific items required in product data submittal outside of these requirements.
 - c. Provide pump curves, operation characteristics, capacities, ambient noise criteria, etc. for equipment.
 - d. For vibration isolation of equipment, list make and model selected with operating load and deflection.
 - e. See Division 23, HVAC individual Sections for additional submittal requirements outside of these requirements.
5. Maximum of two reviews of submittal package. Arrange for additional reviews and/or early review of long-lead items; Bear costs of these additional reviews at Engineer's hourly rates. Incomplete submittal packages/submittals will be returned to contractor without review.
 6. Resubmission Requirements: Make corrections or changes in submittals as required, and in consideration of Engineer's comments. Identify Engineer's comments and provide an individual response to each of the Engineer's comments. Cloud changes in the submittals and further identify changes which are in response to Engineer's comments.
 7. Trade Coordination: Include physical characteristics, electrical characteristics, device layout plans, wiring diagrams, and connections as required by Division 23, HVAC Coordination Documents. For equipment with electrical connections, furnish copy of approved submittal for inclusion in Division 26, Electrical submittals.
 8. Make provisions for openings in building for admittance of equipment prior to start of construction or ordering of equipment.
 9. Substitutions and Variation from Basis of Design:
 - a. The Basis of Design designated product establishes the qualities and characteristics for the evaluation of any comparable products by other listed acceptable manufacturers if included in this Specification or included in an approved Substitution Request as judged by the Design Professional.
 - b. If substitutions and/or equivalent equipment/products are being proposed, it is the responsibility of parties concerned, involved in, and furnishing the substitute and/or equivalent equipment to verify and compare the characteristics and requirements of that furnished to that specified and/or shown. If greater capacity and/or more materials and/or more labor is required for the rough-in, circuitry or connections than for the item specified and provided for, then provide compensation for additional charges required for the proper rough-in, circuitry and connections for the equipment being furnished. No additional charges above the Base Bid, including resulting charges for work performed under other Divisions, will be allowed for such revisions. Coordinate with the requirements of "Submittals". For any product marked "or approved equivalent", a substitution request must be submitted to Engineer for approval prior to purchase, delivery or installation.
 10. Shop Drawings: Provide coordinated shop drawings which include physical characteristics of all systems, equipment, ductwork and piping layout plans, and control wiring diagrams. Reference individual Division 23, HVAC Specification Sections for additional requirements for shop drawings outside of these requirements.
 - a. Provide Shop Drawings indicating access panel locations for items that require Code or maintenance access, size and elevation for approval prior to installation.

11. Samples: Provide samples when requested by individual Sections.
12. Resubmission Requirements:
 - a. Make any corrections or change in submittals when required. Provide submittals as specified. The engineer will not be required to edit and/or interpret the Contractor's submittals. Indicate changes for the resubmittal in a cover letter with reference to page(s) changed and reference response to comment. Cloud changes in the submittals.
 - 1) Resubmit for review until review indicates no exception taken or make "corrections as noted".
 - 2) When submitting drawings for Engineers re-review, clearly indicate changes on drawings and "cloud" any revisions. Submit a list describing each change.
13. Operation and Maintenance Manuals, Owner's Instructions:
 - a. Submit, at one time, electronic files (PDF format) of manufacturer's operation and maintenance instruction manuals and parts lists for equipment or items requiring servicing. Include valve charts. Submit data when work is substantially complete and in same order format as submittals. Include name and location of source parts and service for each piece of equipment.
 - 1) Include copy of approved submittal data along with submittal review letters received from Engineer. Data to clearly indicate installed equipment model numbers. Delete or cross out data pertaining to other equipment not specific to this project.
 - 2) Include copy of manufacturer's standard Operations and Maintenance for equipment. At front of each tab, provide routine maintenance documentation for scheduled equipment. Include manufacturer's recommended maintenance schedule and highlight maintenance required to maintain warranty. Furnish list of routine maintenance parts, including part numbers, sizes, quantities, relevant to each piece of equipment: belts, motors, lubricants, and filters.
 - 3) Include Warranty per Division 00, Procurement and Contracting Requirements and Division 01, General Requirements, Section 23 00 00, HVAC Basic Requirements and individual Sections.
 - 4) Include product certificates of warranties and guarantees.
 - 5) Include copy of complete parts list for equipment. Include available exploded views of assemblies and sub assemblies.
 - 6) Include copy of startup and test reports specific to each piece of equipment.
 - 7) Include copy of final air and water systems balancing log along with pump, fan and distribution system operating data.
 - 8) Include commissioning reports.
 - 9) Include copy of valve charts/schedules.
 - 10) Engineer will return incomplete documentation without review. Engineer will provide one set of review comments in Submittal Review format. Contractor must arrange for additional reviews; Contractor to bear costs for additional reviews at Engineer's hourly rates.
 - b. Thoroughly instruct Owner in proper operation of equipment and systems. Where noted in individual Sections, training will include classroom instruction with applicable training aids and systems demonstrations. Field instruction per Section 23 00 00, HVAC Basic Requirements Article titled "Demonstration".
 - c. Copies of certificates of code authority inspections, acceptance, code required acceptance tests, letter of conformance and other special guarantees, certificates of warranties, specified elsewhere or indicated on Drawings.

14. Record Drawings:
 - a. Maintain at site at least one set of drawings for recording "As-constructed" conditions. Indicate on drawings changes to original documents by referencing revision document, and include buried elements, location of cleanouts, and location of concealed mechanical items. Include items changed by field orders, supplemental instructions, and constructed conditions.
 - b. Record Drawings are to include equipment and fixture/connection schedules, control dampers, fire smoke dampers, fire dampers, valves, bottom of pipe, duct and equipment elevations and dimensioned locations for all distribution systems (hydronic and air). Invert elevations and dimensioned locations for underground systems below grade to 5-feet outside building that accurately reflect "as constructed or installed" for project.
 - c. At completion of project, input changes to original project Revit Model and make one set of black-line drawings created from Revit Model in version/release equal to contract drawings. Submit Revit disk and drawings upon substantial completion.
 - d. See Division 23, HVAC individual Sections for additional items to include in record drawings.

1.5 QUALITY ASSURANCE

- A. Regulatory Requirements: Work and materials installed to conform with all local, State and Federal codes, and other applicable laws and regulations. Where code requirements are at variance with Contract Documents, meet code requirements as a minimum requirement and include costs necessary to meet these in Contract. Machinery and equipment are to comply with OSHA requirements, as currently revised and interpreted for equipment manufacturer requirements. Install equipment provided per manufacturer recommendations.
- B. Whenever this Specification calls for material, workmanship, arrangement or construction of higher quality and/or capacity than that required by governing codes, higher quality and/or capacity take precedence.
- C. Drawings are intended to be diagrammatic and reflect the Basis of Design manufacturer's equipment. They are not intended to show every item in its exact dimensions, or details of equipment or proposed systems layout. Verify actual dimensions of systems (i.e., piping) and equipment proposed to assure that systems and equipment will fit in available space. Contractor is responsible for design and construction costs incurred for equipment other than Basis of Design, including, but not limited to, architectural, structural, electrical, HVAC, fire sprinkler, and plumbing systems.
- D. Manufacturer's Instructions: Follow manufacturer's written instructions. If in conflict with Contract Documents, obtain clarification. Notify Engineer/Architect, in writing, before starting work.
- E. Items shown on Drawings are not necessarily included in Specifications or vice versa. Confirm requirements in all Contract Documents.
- F. Provide products that are UL listed.
- G. Piping and duct insulation products to contain less than 0.1 percent by weight PBDE in all insulating materials.

- H. ASME Compliance: ASME listed water heaters and boilers with an input of 200,000 BTUH and higher, hot water storage tanks which exceed 120 gallons, and hot water expansion tanks which are connected to ASME rated equipment or required by code or local jurisdiction.
- I. Provide safety controls required by National Boiler Code (ASME CSD 1) for boilers and water heaters with an input of 400,000 BTUH and higher.

1.6 WARRANTY

- A. Provide written warranty covering the work for a period of one year from date of Substantial Completion in accordance with Division 00, Contracting and Procurement Requirements, Division 01, General Requirements, Section 23 00 00, HVAC Basic Requirements and individual Division 23, HVAC Sections.
- B. Sections under this Division can require additional and/or extended warranties that apply beyond basic warranty under Division 01, General Requirements and the General Conditions. Confirm requirements in all Contract Documents.

1.7 COORDINATION DOCUMENTS

- A. Prior to construction, coordinate installation and location of HVAC equipment, ductwork, grilles, diffusers, piping, equipment, fire sprinklers, plumbing, cable trays, lights, and electrical services with architectural and structural requirements, and other trades (including ceiling suspension, and tile systems), and provide maintenance access requirements. Coordinate with submitted architectural systems (i.e. roofing, ceiling, finishes) and structural systems as submitted, including footings and foundation. Identify zone of influence from footings and ensure systems are not routed within the zone of influence.
- B. Advise Architect in event a conflict occurs in location or connection of equipment. Bear costs resulting from failure to properly coordinate installation or failure to advise Architect of conflict.
- C. Verify in field exact size, location, invert, and clearances regarding existing material, equipment and apparatus, and advise Architect of discrepancies between that indicated on Drawings and that existing in field prior to installation related thereto.
- D. Submit final Coordination Drawings with changes as Record Drawings at completion of project.

1.8 VIRIDIANT REQUIREMENTS

- A. Project seeks Net-Zero ready, as outlined by Viridiant's Residential Net Zero Program.
- B. Obtain list of credits sought by project. Be familiar with requirements for credits. See Division 00, Procurement and Contracting Requirements and Division 01, General Requirements for additional requirements.
- C. Provide materials and services as outlined in appropriate Viridiant Residential Net-Zero Reference Guide.

- D. Provide documentation as outlined in appropriate Viridiant Residential Net-Zero Reference Guide.
- E. Coordinate start-up, testing, training, and installation with Commissioning Agent as required to meet commissioning requirements.
- F. Provide adequate schedule for construction activities such as building flush out.

PART 2 - PRODUCTS

2.1 MANUFACTURERS

- A. Articles, fixtures, and equipment of a kind to be standard product of one manufacturer, including but not limited to pumps, fans, valves, control devices, air handlers, vibration isolation devices, etc.

2.2 STANDARDS OF MATERIALS AND WORKMANSHIP

- A. Base contract upon furnishing materials as specified. Materials, equipment, and fixtures used for construction are to be new, latest products as listed in manufacturer's printed catalog data and are to be UL or ETL approved or have adequate approval or be acceptable by State, County, and City authorities.
- B. Names and manufacturer's names denote character and quality of equipment desired and are not to be construed as limiting competition.
- C. Hazardous Materials:
 - 1. Comply with local, State of Virginia, and Federal regulations relating to hazardous materials.
 - 2. Comply with Division 00, Procurement and Contracting Requirements and Division 01, General Requirements for this project relating to hazardous materials.
 - 3. Do not use any materials containing a hazardous substance. If hazardous materials are encountered, do not disturb; immediately notify Owner and Architect. Hazardous materials will be removed by Owner under separate contract.

PART 3 - EXECUTION

3.1 ACCESSIBILITY AND INSTALLATION

- A. Confirm Accessibility and Installation requirements in Division 00, Procurement and Contracting Requirements and Division 01, General Requirements, Section 23 00 00, HVAC Basic Requirements and individual Division 23, HVAC Sections.
- B. Install equipment having components requiring access (i.e., drain pans, drains, control operators, valves, motors and vibration isolation devices) so that they may be serviced, reset, replaced or recalibrated by service people with normal service tools and equipment. Do not install equipment in obvious passageways, doorways, scuttles or crawlspaces which would impede or block intended usage.

- C. Install equipment and products complete as directed by manufacturer's installation instructions including all appurtenances recommended in manufacturer's installation instructions, at no additional charge to Owner. Obtain installation instructions from manufacturer prior to rough-in of equipment and examine instructions thoroughly. When requirements of installation instructions conflict with Contract Documents, request clarification from Architect prior to proceeding with installation. This includes proper installation methods, sequencing and coordination with other trades and disciplines.
- D. Earthwork:
1. Confirm Earthwork requirements in Contract Documents. In absence of specific requirements, comply with individual Division 23, HVAC Sections and the following:
 - a. Perform excavation, dewatering, shoring, bedding, and backfill required for installation of work in this Division in accordance with related earthwork Sections. Contact utilities and locate existing utilities prior to excavation. Repair any work damaged during excavation or backfilling.
 - b. Excavation: Do not excavate under footings, foundation bases, or retaining walls.
 - c. Provide protection of underground systems. Review the project Geotechnical Report for references to corrosive or deleterious soils which will reduce the performance or service life of underground systems materials.
- E. Firestopping:
1. Confirm Firestopping requirements in Division 07, Thermal and Moisture Protection. In absence of specific requirements, comply with individual Division 23, HVAC Sections and the following:
 - a. Coordinate location and protection level of fire and/or smoke rated walls, ceilings, and floors. When these assemblies are penetrated, seal around piping, ductwork and equipment with approved firestopping material. Install firestopping material complete as directed by manufacturer's installation instructions. Meet requirements of ASTM E814, Standard Test Method for Fire Tests of Through-Penetration Fire Stops.
- F. Pipe Installation:
1. Provide installation of piping systems coordinated to account for expansion and contraction of piping materials and building, as well as anticipated settlement or shrinkage of building. Install work to prevent damage to piping, equipment, and building and its contents. Provide piping offsets, loops, seismic flexible joints, expansion joints, sleeves, anchors or other means to control pipe movement and minimize forces on piping. Verify anticipated settlement and/or shrinkage of building with Project Structural Engineer. Verify construction phasing, type of building construction products and rating for coordinating installation of piping systems.
 2. Include provisions for servicing and removal of equipment without dismantling piping.
- G. Plenums:
1. Plenums: Materials within plenums shall be noncombustible or shall have a flame spread index of not more than 25 and a smoke-developed index of not more than 50 when tested in accordance with ASTM E 84 or UL 723. Immediately notify Architect / Engineer of any discrepancy.

3.2 REVIEW AND OBSERVATION

- A. Confirm Review and Observation requirements in Division 00, Procurement and Contracting Requirements, Division 01, General Requirements, Section 23 00 00, HVAC Basic Requirements and individual Division 23, HVAC Sections.
- B. Notify Architect, in writing, at following stages of construction so that they may, at their option, visit site for review and construction observation:
 - 1. Underground system installation prior to backfilling.
 - 2. Prior to covering walls.
 - 3. Prior to ceiling cover/installation.
 - 4. After major equipment is installed.
 - 5. When main systems, or portions of, are being tested and ready for inspection by AHJ.
- C. Final Punch:
 - 1. Prior to requesting a final punch visit from the Engineer, request from Engineer the Mechanical Precloseout Checklist, complete the checklist confirming completion of systems' installation, and return to Engineer. Request a final punch visit from the Engineer, upon Engineer's acceptance that the mechanical systems are ready for final punch.
 - 2. Costs incurred by additional trips required due to incomplete systems will be the responsibility of the Contractor.

3.3 CONTINUITY OF SERVICE

- A. Confirm requirements in Division 00, Procurement and Contracting Requirements and Division 01, General Requirements. In absence of specific requirements, comply with individual Division 23, HVAC Sections and the following:
 - 1. During remodeling or addition to existing structures, while existing structure is occupied, current services to remain intact until new construction, facilities or equipment is installed.
 - 2. Prior to changing over to new service, verify that every item is thoroughly prepared. Install new piping and ductwork, and wiring to point of connection. Where existing systems are being utilized, clean existing distribution systems (ductwork, piping, fans, air handlers) prior to connecting new ductwork or piping.
 - 3. Coordinate transfer time to new service with Owner. If required, perform transfer during off peak hours. Once changeover is started, pursue to its completion to keep interference to a minimum.
 - a. If overtime is necessary, there will be no allowance made by Owner for extra expense for such overtime or shift work.
 - 4. Organize work to minimize duration of power interruption.

3.4 CUTTING AND PATCHING

- A. Confirm Cutting and Patching requirements in Division 00, Procurement and Contracting Requirements and Division 01, General Requirements. In absence of specific requirements, comply with individual Division 23, HVAC Sections and the following:
 - 1. Proposed floor cutting/core drilling/sleeve locations to be approved by Project Structural Engineer. Submit proposed locations to Architect/Project Structural Engineer. Where

slabs are of post tension construction, perform x-ray scan of proposed penetration locations and submit scan results including proposed penetration locations to Project Structural Engineer/Architect for approval. Where slabs are of waffle type construction, show column cap extent and cell locations relative to proposed penetration(s).

2. Cutting, patching and repairing for work specified in this Division including plastering, masonry work, concrete work, carpentry work, and painting included under this Section will be performed by skilled craftsmen of each respective trade in conformance with appropriate Division of Work.
3. Additional openings required in building construction to be made by drilling or cutting. Use of jack hammer is specifically prohibited. Patch openings in and through concrete and masonry with grout.
4. Restore new or existing work that is cut and/or damaged to original condition. Patch and repair specifically where existing items have been removed. This includes repairing and painting walls, ceilings, etc. where existing conduit and devices are removed as part of this project. Where alterations disturb lawns, paving, and walks, surfaces to be repaired, refinished and left in condition matching existing prior to commencement of work.
5. Additional work required by lack of proper coordination will be provided at no additional cost to the Owner.

3.5 EQUIPMENT SELECTION AND SERVICEABILITY

- A. Replace or reposition equipment which is too large or located incorrectly to permit servicing, at no additional cost to Owner.
- B. Maintain design intent where equipment other than as shown as Basis of Design in Contract Documents is provided. Where equipment requires ductwork or piping arrangement, controls/control diagrams, or sequencing different from that indicated in Contract Documents, provide at no additional cost to Owner.

3.6 DELIVERY, STORAGE AND HANDLING

- A. Confirm requirements in Division 00, Procurement and Contracting Requirements and Division 01, General Requirements. In absence of specific requirements, comply with individual Division 23, HVAC Sections and the following:
 1. Handle materials delivered to project site with care to avoid damage. Store materials on site inside building or protected from weather, dirt and construction dust. Insulation and lining that becomes wet from improper storage and handling to be replaced before installation. Products and/or materials that become damaged due to water, dirt, and/or dust as a result of improper storage to be replaced before installation.
 2. Protect equipment and pipe to avoid damage. Close pipe openings with caps or plugs. Keep motors and bearings in watertight and dustproof covers during entire course of installation.
 3. Protect bright finished shafts, bearing housings and similar items until in service.

3.7 DEMONSTRATION

- A. Confirm Demonstration requirements in Division 00, Procurement and Contracting Requirements and Division 01, General Requirements, Section 23 00 00, HVAC Basic Requirements and individual Division 23, HVAC Sections.

- B. Upon completion of work and adjustment of equipment and test systems, demonstrate to Owner's Authorized Representative, Architect and Engineer that equipment furnished and installed or connected under provisions of these Specifications functions in manner required. Provide field instruction to Owner's Maintenance Staff as specified in Division 01, General Requirements, Section 23 00 00, HVAC Basic Requirements and individual Division 23, HVAC Sections.
- C. Manufacturer's Field Services: Furnish services of a qualified person at time approved by Owner, to instruct maintenance personnel, correct defects or deficiencies, and demonstrate to satisfaction of Owner that entire system is operating in satisfactory manner and complies with requirements of other trades that may be required to complete work. Complete instruction and demonstration prior to final job site observations.

3.8 CLEANING

- A. Confirm Cleaning requirements in Division 00, Procurement and Contracting Requirements, Division 01, General Requirements, Section 23 00 00, HVAC Basic Requirements and individual Division 23, HVAC Sections.
- B. Upon completion of installation, thoroughly clean exposed portions of equipment, removing temporary labels and traces of foreign substances. Throughout work, remove construction debris and surplus materials accumulated during work.

3.9 INSTALLATION

- A. Confirm Installation requirements in Division 00, Procurement and Contracting Requirements, Division 01, General Requirements, Section 23 00 00, HVAC Basic Requirements and individual Division 23, HVAC Sections.
- B. Install equipment and fixtures in accordance with manufacturer's installation instructions, plumb and level and firmly anchored to vibration isolators. Maintain manufacturer's recommended clearances.
- C. Start up equipment, in accordance with manufacturer's start-up instructions, and in presence of manufacturer's representative. Test controls and demonstrate compliance with requirements. Replace damaged or malfunctioning controls and equipment.
 - 1. Do not place equipment in sustained operation prior to initial balancing of HVAC systems.
- D. Provide miscellaneous supports/metals required for installation of equipment, piping and ductwork.

3.10 PAINTING

- A. Confirm Painting requirements in Division 01, General Requirements and Division 09, Finishes. In absence of specific requirements, comply with individual Division 23, HVAC Sections and the following:
 - 1. Ferrous Metal: After completion of work, thoroughly clean and paint exposed supports constructed of ferrous metal surfaces in mechanical rooms, i.e., hangers, hanger rods,

- equipment stands, with one coat of black asphalt varnish for exterior or black enamel for interior, suitable for hot surfaces.
2. After acceptance by Authority Having Jurisdiction (AHJ), In a mechanical room, on roof or other exposed areas, machinery and equipment not painted with enamel to receive two coats of primer and one coat of rustproof enamel, colors as selected by Architect.
 3. See individual equipment Specifications for other painting.
 4. Structural Steel: Repair damage to structural steel finishes or finishes of other materials damaged by cutting, welding or patching to match original.
 5. Piping and Ductwork: Clean, primer coat and paint exposed piping and ductwork on roof or at other exterior locations with two coats paint suitable for metallic surfaces and exterior exposures. Color selected by Architect.
 6. Covers: Covers such as manholes, cleanouts and the like will be furnished with finishes which resist corrosion and rust.

3.11 DEMOLITION

- A. Confirm requirements in Division 01, General Requirements and Division 02, Existing Conditions. In absence of specific requirements, comply with individual Division 23, HVAC Sections and the following:
 1. Scope:
 - a. It is the intent of these documents to provide necessary information and adjustments to the HVAC system required to meet code, and accommodate installation of new work.
 - b. Coordinate with Owner so that work can be scheduled not to interrupt operations, normal activities, building access or access to different areas.
 - c. Existing Conditions: Determine exact location of existing utilities and equipment before commencing work, compensate Owner for damages caused by failure to exactly locate and preserve utilities. Replace damaged items with new material to match existing. Promptly notify Owner if utilities are found which are not shown on Drawings.
 2. Equipment: Unless otherwise directed, equipment, fixtures, or fittings being removed as part of demolition process are Owner's property. Remove other items not scheduled to be reused or relocated from job site as directed by Owner.
 3. Unless specifically indicated on Drawings, remove exposed, unused ductwork and piping to behind finished surfaces (floor, walls, ceilings, etc.). Cap and patch surfaces to match surrounding finish.
 4. Unless specifically indicated on Drawings, remove unused equipment, fixtures, fittings, rough-ins, and connectors. Removal is to be to a point behind finished surfaces (floors, walls, and ceilings).

3.12 ACCEPTANCE

- A. Confirm requirements in Division 00, Procurement and Contracting Requirements and Division 01, General Requirements. In absence of specific requirements, comply with individual Division 23, HVAC Sections and the following:
 1. System cannot be considered for acceptance until work is completed and demonstrated to Architect that installation is in strict compliance with Specifications, Drawings and manufacturer's installation instructions, particularly in reference to following:
 - a. Testing and Balancing Reports
 - b. Cleaning

- c. Operation and Maintenance Manuals
- d. Training of Operating Personnel
- e. Record Drawings
- f. Warranty and Guaranty Certificates
- g. Start-up/Test Document
- h. Commissioning Reports

3.13 FIELD QUALITY CONTROL

- A. Confirm Field Quality Control requirements in Division 01, General Requirements, Section 23 00 00, HVAC Basic Requirements and individual Division 23, HVAC Sections.
- B. Tests:
 - 1. Conduct tests of equipment and systems to demonstrate compliance with requirements specified. Reference individual Specification Sections for required tests. Document tests and include in Operation and Maintenance Manuals.
 - 2. During site evaluations by Architect or Engineer, provide appropriate personnel with tools to remove and replace trims, covers, and devices so that proper evaluation of installation can be performed.

3.14 LETTER OF CONFORMANCE

- A. Provide Letter of Conformance, copies of manufacturers' warranties and extended warranties with a statement that HVAC items were installed in accordance with manufacturer's recommendations, UL listings and FM Global approvals. Include Letter of Conformance, copies of manufacturers' warranties and extended warranties in Operation and Maintenance Manuals.

3.15 ELECTRICAL INTERLOCKS

- A. Where equipment motors are to be electrically interlocked with other equipment for simultaneous operation, utilize equipment wiring diagrams to coordinate with electrical systems so that proper wiring of equipment involved is affected.

3.16 TEMPORARY HEATING, COOLING AND HUMIDITY CONTROL

- A. Provide temporary heating, cooling, controls, humidification and dehumidification as required to facilitate the construction of the project. Size and select temporary system based on the requirements of the various trades during construction. This includes, but is not limited to, drywall, case work, wood flooring and wood finishes that are subject to warping. Size and install system to prevent mold growth. Coordinate the location of the temporary system. The house system can be used. Develop a procedure for how the house system will be used including a sketch depicting the house system, how filtration will be used to prevent construction debris from entering the system and how often the filters will be changed, how the ductwork will be cleaned after use to ensure a clean system is turned over to the Owner and how the units are sized. Submit this procedure to the Mechanical Engineer for review. Follow National Air Duct Cleaners Association (NADCA) duct cleaning procedures and guidelines. Warranties for the house system, if new, to commence when the Owner moves in if house system is used as the means to maintain the climate within the building during construction. Include this warranty requirement in the original bid or proposal amount. Coordinate and provide any temporary power, controls, ductwork, piping, plumbing anchorage, miscellaneous steel and structural supports required to support the temporary system. Installation of the system to comply with all applicable codes and be acceptable to the Authority Having Jurisdiction (AHJ).

END OF SECTION

SECTION 23 0513 - COMMON MOTOR REQUIREMENTS FOR HVAC EQUIPMENT

PART 1 - GENERAL

1.1 SUMMARY

- A. Work Included:
 - 1. Starters
 - 2. Shaft Grounding

1.2 RELATED SECTIONS

- A. Contents of Division 23, HVAC and Division 01, General Requirements apply to this Section.

1.3 REFERENCES AND STANDARDS

- A. References and Standards as required by Section 23 00 00, HVAC Basic Requirements and Division 01, General Requirements.
- B. In addition, meet the following:
 - 1. NEMA Premium Efficiency
 - 2. Energy Policy Act (EPACT), latest applicable version(s) for minimum motor efficiencies.

1.4 SUBMITTALS

- A. Submittals as required by Section 23 00 00, HVAC Basic Requirements and Division 01, General Requirements.

1.5 QUALITY ASSURANCE

- A. Quality assurance as required by Section 23 00 00, HVAC Basic Requirements and Division 01, General Requirements.
- B. In addition, meet the following:
 - 1. Field Installed Motors: Installed motors to be of single type, from one source and from a single manufacturer.
 - 2. Electrical components and materials to be UL and ETL listed/labeled as suitable for location and use.

1.6 WARRANTY

- A. Warranty of materials and workmanship as required by Section 23 00 00, HVAC Basic Requirements and Division 01, General Requirements.
- B. In addition, provide:
 - 1. For motors 50 HP and larger, provide 5-year manufacturer's limited warranty from date of substantial completion.

PART 2 - PRODUCTS

2.1 MANUFACTURERS

A. Starters:

1. Cerus
2. Eaton Electrical
3. General Electric
4. Siemens
5. Schneider Electric/Square D
6. Or approved equivalent.

B. Shaft Grounding:

1. Shaft Grounding Inc.
2. Aegis SGR Bearing Protection Ring
3. Or approved equivalent.

2.2 STARTERS

A. Single Phase Motors:

1. Manual across-the-line starting switch having toggle-operated switch pilot running light and built-in thermal overload device with heating element rated not more than 115 percent motor full load current indicated on name plate of motor to be protected. Surface mount starters. Provide NEMA-1 enclosure.
2. Overload relays to be melting alloy type with a replaceable control circuit module. Thermal units to be interchangeable. Starter to be non operative if thermal unit is removed.
3. Single-phase motors with automatic controls. Provide motor-rated relay with coils rated for control voltage.

B. Starters up to Size 8 to be suitable for the addition of a minimum of three external auxiliary contacts (normally open or normally closed). Contactor, coils, and relays to perform the control functions of the associated equipment and control sequence.

C. Three Phase Motors up to and Including 15 HP:

1. Provide enclosed type magnetic across-the-line starter with thermal overload and undervoltage protection.
2. Operator: "Start-Stop" pushbutton, except where automatic control is indicated on Drawings or specified. Then provide "Hand-Off-Auto" selector switch.
3. Starters for 3-phase motors to have overload protection in each of the three legs, with external manual reset.
4. Unless indicated on Drawings or in Specifications, furnish motor starters with a neon pilot light. Neon lights are required for exhaust fan switches.
5. Equip starters with integral transformer and coil for control circuit. Coordinate coil voltage with control voltage.

D. For Three Phase Motors Greater than 15 HP:

1. Provide combination starter and fused safety disconnect integral in the same enclosure. Utilize Type 'RK' or 'L' fuses. Provide fuse block with rejection type fuse holders. Size fuses per motor manufacturer's recommendations.
2. Provide a solid-state reduced voltage starter, consisting of power section, one-piece removable printed circuit logic board and field wiring interface terminals. Logic board uses quick disconnect plug-in connectors for current transformers inputs, line-and-load voltage inputs, SCR gate firing output circuits and status panel. 3-phase current sensing via current transformers. Class 10 electronic overload protection.
3. Motor starters to include the following protections:
 - a. Inverse time running overcurrent protection.
 - b. 250 percent to 500 percent current limit adjustment.
 - c. Minimum and maximum voltage adjustments.
 - d. Voltage stability adjustment.
 - e. Single-phase protection with built-in short-time delay.
 - f. Undervoltage protection with built-in short time delay.
 - g. MOV surge suppression protection of SCRs rated 10 percent above the rated voltage.
 - h. Phase sequence protection.
4. Display: Door-mounted status LCD alphanumeric or LED display indicating run, undervoltage, phase loss, phase current unbalance, overcurrent trip, overtemperature, current limit, end of ramp, and incorrect phase rotation.
5. Enclosure: NEMA 12. Operator: "Start-Stop" pushbutton, except where automatic control is indicated on Drawings or specified, then provide "Hand-Off-Auto" selector switch
6. Input/Output Relays: Provide relays as required to provide the control sequence.
7. UL 508 listed.

2.3 SHAFT GROUNDING

- A. Variable Speed Motor Shaft Grounding: Shaft grounding ring; solid ring type.
- B. Provide shaft grounding assembly on motors controlled by variable frequency drive. Shaft grounding device to be in the form of brush that resides on the motor shaft. Brush assembly shall be capable of tolerating misalignment and maintaining rotating contact throughout the motors life.
- C. Material: Material used in the grounding assembly shall be stable material commonly used within industry that is not believed to constitute a hazardous material under Occupational Safety & Health Administration (OSHA) regulations.
- D. Brushes: Specifically developed carbon compounds of sustained performance with wear life expectancy of 3 years minimum.
- E. Seals: Sealed type to keep contaminants from entering the shaft grounding system in wet or severe environment applications.
- F. Shaft Grounding Assembly: For clean room air handling systems, use the type that contains the wear products within a special enclosure within the shaft grounding system.

PART 3 - EXECUTION

3.1 GENERAL INSTALLATION

- A. Coordinate location of disconnect and starter or motor controller. Combination starter/disconnects may be used in lieu of separate items.
- B. Explosion-Proof Motors: UL approved and labeled for hazard classification, with over temperature protection.
- C. Provide inverter ready motors per NEMA MG1-30 for variable speed drive or soft-start starter use. Provide shaft grounding for motors over 2 HP serving variable speed drives. Provide shaft grounding and insulated bearings on motors 25 HP and larger serving variable speed drives. Shielded cable required for power wiring from variable speed drive to motor connection.
- D. Unless otherwise indicated, motors 1-HP and larger to meet/exceed NEMA Premium Efficiency and latest EPACK.
- E. Vertical in-line pump motors per NEMA MG1 vertical motor requirements.
- F. Exception: Motors less than 250 watts, for intermittent service, motors furnished with equipment manufacturer's standard package equipment need not conform to these specifications.
- G. Single phase motors for air compressors and pumps: Capacitor start type.
- H. Motors located in exterior locations or wet air streams are to be of totally enclosed type.
- I. Motors located in outdoor, wet/wash-down locations: Totally enclosed weatherproof epoxy-sealed type. Provide protective covering for electronically commutated motors located in outdoor or wet/wash-down locations.
- J. Disconnects: Provided by Division 26, Electrical unless specified otherwise.
- K. After completing equipment installation, inspect unit components. Remove paint splatters and other spots, dirt, and debris. Repair damaged finish to match original finish.

3.2 STARTER INSTALLATION

- A. Install starters in accordance with manufacturer's instructions.
- B. Coordinate disconnect requirements and location with Division 26, Electrical if not integral to starter. If starter is installed out of line of sight of motor, provide additional disconnect at motor per code.
- C. Provide NEMA housing appropriate to installation location.
- D. Provide supports and install securely, in neat and workmanlike manner, as specified in NECA 1.
- E. Meet mounting height and accessible location requirements per local code.

- F. Provide fuses for fusible switches.
- G. Select and install overload heater elements in motor starters to match installed motor characteristics.
- H. Single phase 120 Volt starter: if not furnished as single packaged controller/disconnect, provide contactors, relays, wiring and devices necessary to match sequence of operation for equipment.

3.3 SHAFT GROUNDING INSTALLATION

- A. Shaft grounding assembly installation not to affect the motor manufacturer warranty. Where the severe environment conditions require application of the shaft grounding types that are screwed into the motor shaft, the installation of the shaft grounding system performed either by the motor manufacturer or by the motor manufacturer authorized facility.
- B. Bond the brush to the closest ground point using code sized green insulated stranded copper conductor per manufacturer instructions.
- C. Test and verify the performance of the assembly to ensure that under no conditions the shaft exceeds 3 volts.
- D. Install securely on firm foundation. Mount ball bearing motors with shaft in any position.
- E. Check line voltage and phase and ensure agreement with nameplate.
- F. Verify motor rotation.

END OF SECTION

SECTION 23 0519 - METERS AND GAUGES FOR HVAC PIPING

PART 1 - GENERAL

1.1 SUMMARY

- A. Work Included:
 - 1. Pressure Gauges
 - 2. Thermometers
 - 3. Dial Thermometers
 - 4. Separable Sockets
 - 5. Thermometer Wells
 - 6. Duct Thermometer Support Flanges
 - 7. Differential and Filter Pressure Gauges
 - 8. Pressure-Gauge Fittings
 - 9. Test Plugs

1.2 RELATED SECTIONS

- A. Contents of Division 23, HVAC and Division 01, General Requirements apply to this Section.

1.3 REFERENCES AND STANDARDS

- A. References and Standards as required by Section 23 00 00, HVAC Basic Requirements and Division 01, General Requirements.

1.4 SUBMITTALS

- A. Submittals as required by Section 23 00 00, HVAC Basic Requirements and Division 01, General Requirements.
- B. In addition, provide:
 - 1. Maintenance Materials:
 - a. Extra gauge Oil for Inclined Manometers: One Bottle.
 - b. Extra Pressure Gauges: One.

1.5 QUALITY ASSURANCE

- A. Quality assurance as required by Section 23 00 00, HVAC Basic Requirements and Division 01, General Requirements.

1.6 WARRANTY

- A. Warranty of materials and workmanship as required by Section 23 00 00, HVAC Basic Requirements and Division 01, General Requirements.

PART 2 - PRODUCTS

2.1 MANUFACTURERS

- A. Pressure Gauges:

1. Terrice Model 600CB.
 2. Dwyer Instruments, Inc.
 3. Moeller Instrument Co., Inc.
 4. Omega Engineering, Inc.
 5. Or approved equivalent.
- B. Thermometers:
1. Terrice Model BX9.
 2. Ashcroft
 3. Weiss
 4. Marshaltown
 5. Weksler
 6. Or approved equivalent.
- C. Dial Thermometers:
1. Terrice Model 80742.
 2. Ashcroft
 3. Weiss
 4. Marshaltown
 5. Weksler
 6. Or approved equivalent.
- D. Separable Sockets:
1. Kimray
 2. Weiss
 3. Terrice
 4. Or approved equivalent.
- E. Thermometer Wells:
1. Ashcroft
 2. Omega
 3. Weiss
 4. Or approved equivalent.
- F. Duct Thermometer Support Flanges:
1. Terrice
 2. Ashcroft
 3. Weiss
 4. Marshaltown
 5. Weksler
 6. Or approved equivalent.
- G. Differential and Filter Pressure Gauges:
1. Orange Gauges
 2. Midwest
 3. Or approved equivalent.
- H. Pressure-Gauge Fittings:
1. Omega

2. Weiss
3. Trerice
4. Or approved equivalent.

- I. Test Plugs:
 1. Petes Plug
 2. Or approved equivalent.

2.2 PRESSURE GAUGES

- A. ASME B40.100, phosphor-bronze bourdon type, dry type.
 1. Case: Cast aluminum, stem-mounted, flangeless.
 2. Size: 4-1/2 inch diameter.
 3. Window: Clear glass.
 4. Connector: Brass.
 5. Scale: White aluminum with black graduation and markings.
 6. Pointer: Black, adjustable.
 7. Mid-Scale Accuracy: One percent.
 8. Scale: Psi.

2.3 THERMOMETERS

- A. Adjustable Angle: Red-or blue-appearing organic liquid in glass: ASTM E 1; lens front tube, cast aluminum case with enamel finish, cast aluminum adjustable joint with positive locking device; adjustable 360 degrees in horizontal plane, 180 degrees in vertical plane.
 1. Size: 9-inch scale.
 2. Window: Acrylic.
 3. Scale: Aluminum, white background, black graduations and markings.
 4. Stem: 3/4-inch NPT brass (aluminum for installation in air ducts).
 5. Accuracy: 2 percent, per ASTM E 77.
 6. Calibration: 0-160 with 2 Degrees F. graduations.

2.4 DIAL THERMOMETERS

- A. ASTM E 1, cast aluminum case, vapor or liquid actuated with brass or copper bulb, copper or bronze braided capillary, white with black markings and black pointer, glass lens, adjustable 360 degrees in horizontal plane. 180 degrees in vertical plane.
 1. Size: 4-1/2-inch diameter dial.
 2. Lens: Clear glass.
 3. Length of Capillary: Minimum 6-feet (for remote reading if required).
 4. Accuracy: 2 percent.
 5. Calibration: 2 Degrees F. graduations.

2.5 SEPARABLE SOCKETS

- A. Description: Fitting with protective socket for installation in threaded pipe fitting to hold fixed thermometer stem.
 1. Material: Brass, for use in copper piping.
 2. Material: Stainless steel, for use in steel piping.

3. Extension-Neck Length: Nominal thickness of 2-inches, but not less than thickness of insulation. Omit extension neck for sockets for piping not insulated.
4. Insertion Length: To extend to center of pipe.
5. Cap: Threaded, with chain permanently fastened to socket.
6. Heat Transfer Fluid: Oil or graphite.

2.6 THERMOMETER WELLS

- A. Description: Fitting with protective well for installation in threaded pipe fitting to hold test thermometer.
1. Material: Brass for use in copper piping.
 2. Material: Stainless steel, for use in steel piping.
 3. Extension Neck Length: Nominal thickness of 2-inches, but not less than thickness of insulation. Omit extension neck for wells for piping not insulated.
 4. Insertion Length: To extend to center of pipe.
 5. Cap: Threaded, with chain permanently fastened to socket.
 6. Heat Transfer Fluid: Oil or graphite.

2.7 DUCT THERMOMETER SUPPORT FLANGES

- A. Description: Flanged fitting bracket for mounting in hole of duct, with threaded end for attaching thermometer.
1. Extension Neck Length: Nominal thickness of 2-inches, but not less than thickness of exterior insulation.
 2. Insertion-Neck Length: Nominal thickness of 2-inches, but not less than thickness of insulation lining.

2.8 DIFFERENTIAL AND FILTER PRESSURE GAUGES

- A. Service: Air and non-combustible, compatible gases (Natural Gas option available.)
- B. Wetted Materials: Consult factory.
- C. Housing: Die cast aluminum case and bezel, with acrylic cover. Exterior finish is coated gray to withstand 168 hour salt spray corrosion test.
- D. Accuracy: Plus or minus 2 percent of full scale throughout range at 70 degrees F.
- E. Pressure Limits: Minus 20 Hg to 15 PSIG.
- F. Overpressure: Relief plug opens at approximately 25 PSIG standard gauges only.
- G. Temperature Limits: 20 to 140 degrees F.
- H. Size: 4-inch diameter dial face.
- I. Mounting Orientation: Diaphragm in vertical position. Consult factory for other position orientation.
- J. Process Connections: 1/8-inch female NPT duplicate high and low pressure taps, one pair side and one pair back.

- K. Standard Accessories: Two 1/8-inch NPT plugs for duplicate pressure taps, two 1/8-inch pipe thread to rubber tubing adapter and three flush mounting adapters with screws.

2.9 PRESSURE-GAUGE FITTINGS

- A. Valves: NPS 1/4 (DN8) brass or stainless-steel needle type.
- B. Syphons: NPS 1/4 (DN8) coil of brass turbine with threaded ends.
- C. Snubbers: ASME B40.5, NPS 1/4 (DN8) brass bushing with corrosion-resistant porous-metal disc of material suitable for system fluid and working pressure.

2.10 TEST PLUGS

- A. Description: Nickel-plated, brass-body test plug in NPS 1/2 (DN15) fitting.
- B. Body: Length as required to extend beyond insulation.
- C. Pressure Rating: 500 PSIG (3450 kPa) minimum.
- D. Core Inserts: One or two self-sealing valves, suitable for inserting 1/8-inch OD probe from dial-type thermometer or pressure gauge.
- E. Core Material for Air, Water, Oil and Gas: 20 to 200 degrees F (Minus 7 to plus 93 Degrees Celsius), chlorosulfonated polyethylene synthetic rubber.
- F. Test Plug Cap: Gasketed and threaded cap, with retention chain or strap.
- G. Test Kit: Pressure gauge and adapter with probe, two bimetal dial thermometers, and carrying case.
 - 1. Pressure Gauge and Thermometer Ranges: Approximately two times the system's operating conditions.

PART 3 - EXECUTION

3.1 GENERAL INSTALLATION REQUIREMENTS

- A. Provide instruments with scale ranges selected according to service with largest appropriate scale.

3.2 PRESSURE GAUGES

- A. Install pressure gauges in piping tee with pressure gauge cock, located on pipe at most readable position, visible from floor.
- B. Locations: Install in the following locations as a minimum, and elsewhere as indicated.
 - 1. At each pump inlet and outlet.
 - 2. At inlet and discharge of each pressure reducing valve.
 - 3. At makeup water service outlets.
 - 4. At inlet and discharge of each chiller and boiler.

- C. Install in locations where they are easily read from normal operating level. Install vertical to 45 degrees off vertical.
- D. Adjust to final angle, clean windows and lenses, and calibrate to zero.
- E. Pressure Gauge Range/Graduations:

System	Pressure (PSI)	Graduations (PSI)
Chilled Water	0-100	1
Heating Water	0-100	1
Condenser Water	0-100	1
Compressed Air	0-160	1
Steam	0-30	0.2

3.3 THERMOMETERS

- A. Install thermometers in piping systems in sockets in short couplings. Enlarge pipes smaller than 2-1/2-inch for installation of thermometer sockets. Ensure sockets allow clearance from insulation.
- B. Install in locations where they are easily read from normal operating level. Install vertical to 45 degrees off vertical.
- C. Adjust to final angle, clean windows and lenses, and calibrate to zero.
- D. Thermometer Range/Graduations:

System	Temperature (degree F)	Graduations (degrees F)
Chilled Water	25-125	1
Condenser Water	25-125	1
Heating Water	30-240	2
Steam and Condensate	50-400	5

3.4 DIAL THERMOMETERS

- A. Install in vertical upright position, tilted so as to be easily read at floor.

3.5 SEPARABLE SOCKETS

- A. Inspect the openings in the vessel for foreign material and clean the connection ports to remove scale, chips and debris.
- B. Install thermostats with separable sockets. Install the separable socket using good piping practice. Be sure to use TFE tape or pipe thread sealant on external pipe threads.
- C. Never stand directly over or in front of a valve or controller when the system is pressurized.

- D. Assure the separable socket is completely submerged in liquid or flow stream. Partial submersion will give erratic temperature transfer to thermostat.
- E. Pack separable socket full with high temp bearing grease. This helps in heat transfer and prevents air space.

3.6 THERMOMETER WELLS

- A. Install in piping in vertical upright position. Fill well with oil or graphite, secure cup.

3.7 DUCT THERMOMETER SUPPORT FLANGES

- A. Install in wall of duct where duct thermometers are indicated. Attach to duct with screws.

3.8 DIFFERENTIAL AND FILTER PRESSURE GAUGES

- A. Install pressure gauge where exposure to heat and vibration are minimal and where the dial can be easily read. It is also important to install the gauge in a location with undisturbed and continuous flow of the pressure medium.
- B. Provide a needle valve or gauge cock, installed between the process and the pressure gauges.
- C. General: Install pressure gauges in piping tee with pressure gauge cock, located on pipe at most readable position, visible from floor.
- D. Locations: Install in the following locations, and elsewhere as indicated.
 1. At each pump inlet and outlet.
 2. At inlet and discharge of each pressure reducing valve.
 3. At make-up water service outlets.
- E. Install gauges and thermometers in locations where they are easily read from normal operating level. Install vertical to 45 degrees off vertical.

3.9 PRESSURE-GAUGE FITTINGS

- A. Install per manufacturer's instructions and recommendations.
- B. Reference "Pressure Gauges" Article above.

3.10 TEST PLUGS

- A. Locate test plugs adjacent to thermometers and thermometer sockets, adjacent to pressure gauges and pressure gauge taps, adjacent to control device sockets, or where indicated.

END OF SECTION

SECTION 23 0523 - GENERAL-DUTY VALVES FOR HVAC PIPING

PART 1 - GENERAL

1.1 SUMMARY

- A. Work Included:
 - 1. Balancing Valves
 - 2. Ball Valves
 - 3. Butterfly Valves
 - 4. Swing Check Valves
 - 5. Wafer Check Valves

1.2 RELATED SECTIONS

- A. Contents of Division 23, HVAC and Division 01, General Requirements apply to this Section.

1.3 REFERENCES AND STANDARDS

- A. References and Standards as required by Section 23 00 00, HVAC Basic Requirements and Division 01, General Requirements.

1.4 SUBMITTALS

- A. Submittals as required by Section 23 00 00, HVAC Basic Requirements and Division 01, General Requirements.

1.5 QUALITY ASSURANCE

- A. Quality assurance as required by Section 23 00 00, HVAC Basic Requirements and Division 01, General Requirements.

1.6 WARRANTY

- A. Warranty of materials and workmanship as required by Section 23 00 00, HVAC Basic Requirements and Division 01, General Requirements.

PART 2 - PRODUCTS

2.1 MANUFACTURERS

- A. Source Limitations for Valves: Obtain each type of valve from a single source and from a single manufacturer.
- B. Valves, General:
 - 1. Apollo
 - 2. Armstrong
 - 3. ASCO
 - 4. Cla-Val
 - 5. Conbraco
 - 6. Crane

7. Clow
8. Griswold
9. Hammond
10. Hays
11. Jenkins
12. Josam
13. Kennedy
14. Milwaukee
15. Mueller
16. Nibco
17. Red-White Valve
18. Smith
19. Stockham
20. Tour Anderson
21. Wade
22. Watts
23. Wilkins
24. Zurn
25. Or approved equivalent.

C. Balancing Valves:

1. Griswold
2. Hays
3. Armstrong CBV
4. Tour Anderson
5. Or approved equivalent.

D. Ball Valves:

1. See Valves General above.
2. NSF Valves:
 - a. Clow
 - b. Kennedy
 - c. Nibco
 - d. Or approved equivalent.

E. Butterfly Valves:

1. See Valves General above.

F. Swing Check Valves:

1. See Valves General above.

G. Wafer Check Valves:

1. See Valves General above.

2.2 VALVES - GENERAL

A. General:

1. Sizes: Unless otherwise indicated, provide valves of same size as upstream pipe size.

2. Operators: Provide handwheels, fastened to valve stem, for valves other than quarter-turn. Provide lever handle for quarter-turn valves 6 inches and smaller. Provide gear operators for quarter-turn valves 8 inches and larger and plug valves 5 inches and larger. Provide chain-operated sheaves and chains for overhead valves installed over 5 feet above finished floor.
 3. Valve Identification: Manufacturer's name (or trademark) and pressure rating clearly marked on valve body.
- B. Valves in Insulated Piping: With 2-inch stem extension and following features:
1. Ball Valves: With extended operating handle of non-thermal-conductive material, and protective sleeve that allows operation of valve without breaking the vapor seal or disturbing insulation and memory stops that are fully adjustable after insulation is applied.
 - a. Basis of Design Product: Subject to compliance with requirements. Provide NIBCO NIB-SEAL handle extension or comparable product by one of the following.
 - 1) Conbraco Industries, Inc.: Apollo Div.
- C. Valve-End Connections:
1. Flanged: With flanges according to ASME B16.1 for iron valves, ASME B16.5 for steel valves.
 2. Grooved: With grooves according to AWWA C606.
 3. Solder Joint: With sockets according to ASME B16.18.
 4. Threaded: With thread according to ASME B1.20.1.
- D. Valve Bypass and Drain Connections: MSS SP-45.
- E. Building Service:
1. Shutoff and Isolation Valves:
 - a. Pipe Sizes 3 Inches and Smaller: Ball valve.
 2. Drain Service: Ball valves.
 3. Strainer Blow-Off: Ball valve.
 4. Check Valves: Swing or Wafer.

2.3 BALANCING VALVES

- A. Maximum 125 PSIG System Working Water Pressure.
- B. Manual Set Balancing Valves:
1. Valves are to be of the "Y" pattern, equal percentage globe-style and provide three functions:
 - a. Precise flow measurement.
 - b. Precision flow balancing.
 - c. Positive drip-tight shutoff.
 2. Valve to provide multi-turn, 360 degree adjustment with micrometer type indicators located on the valve handwheel. Valves have a minimum of five full 360 degree handwheel turns. 90 degree style ball valves are not acceptable. Valve handle to have hidden memory feature, which will provide a means for locking the valve position after the system is balanced. Valves to be furnished with precision machined venturi built into the valve body to provide highly accurate flow measurement and flow balancing. The

venturi to have two 1/4-inch threaded brass metering ports with check valves and gasketed caps located on the inlet side of the valve. The valve body, stem and plug to be brass. The handwheel to be high-strength resin.

3. 2-1/2 Inches and Larger: Valve body to be either cast iron with integrated cast iron flanges (2-1/2-inch to 12-inch) or ductile iron with industrial standard grooved ends (2-1/2-inch to 12-inch). Valve stem and plug disc to be bronze with handwheel that permits multi-turn adjustments. Sizes 2-1/2-inch and 3-inch: five turns; sizes 4-inch to 6-inch: 6 turns; sizes 8-inch to 10-inch: 12 turns; and size 12-inch: 14 turns. Provide flange adapters to prevent rotation.

C. Automatic Balance Valve:

1. 1/2 Inch and Larger: Construction and attachment style as required by piping system. Internal working parts and removable flow cartridge to be stainless steel. Valves be factory set and automatically limit flow to specified capacities with 5 percent plus or minus accuracy over entire operating pressure differential.

2.4 BALL VALVES

- A. Ball valves on brazed piping are to be three-piece.
- B. 2-1/2 Inches and Smaller: MSS SP-110, 400-600 PSI, two-piece full port ball configuration, bronze body, extended soldered ends for copper pipe and threaded ends for iron pipe, lead-free brass or stainless steel ball, lead-free brass stem, Teflon seat, extended steel handle. Apollo 77CLF 100 Series two-piece.
- C. 3 Inches and Larger: MSS SP-110, 400-600 PSI, three-piece full port ball configuration, bronze body, extended soldered ends for copper pipe and threaded ends for iron pipe, lead-free brass or stainless steel ball, lead-free brass stem, Teflon seat, extended steel handle. Apollo 82-100/82A 140 Series three-piece.
- D. Full Port Ball Valve: 2- to 4-inch ductile iron, ASTM A536, micro finish steel chrome plated or stainless steel ball and stem. TFE seats, 600 PSI.

2.5 BUTTERFLY VALVES

- A. Select lug type valves.
- B. 6 Inches and Smaller: 200 PSI, ductile iron body, extended neck, stainless steel stem with stainless steel disc, reinforced resilient EPDM seat, memory stop control, lever handle through 5 inches, size and worm gear operator for 6 inches and larger. Mount stem in horizontal position. Manual lever and lock Nibco LD2000, Gruvlok 7700 for mechanical coupling fittings. MSS SP-67, Type 1.
- C. 8 Inches and Larger: 200 PSI, ductile iron body, extended neck, stainless steel disc and stem reinforced resilient EPDM seat, memory stop control, lever handle through 5 inches, size and worm gear operator for 6 inches and larger. Mount stem in horizontal position. Manual lever and Gruvlok Series 7700 for mechanical coupling fittings. MSS SP-67, Type 1.

2.6 SWING CHECK VALVES

- A. 2 Inches and Smaller: Class 125, bronze body, horizontal swing, regrinding type, Y-pattern, renewable disc. Nibco 413. MSS SP-80, Type 4.
- B. 2-1/2 Inches and Larger: Class 125, iron body, bolted bonnet, horizontal swing, renewable seat and disc, flanged ends. Nibco F918. MSS SP-71, Type 1.
- C. Gruvlok Check Valve: Horizontal installation. Working pressure to 300 PSI. Ductile body, ASTM A536, and stainless clapper, EPDM, nitrile or optional viton bumper and bonnet seals. Stainless wetted parts.

2.7 WAFER CHECK VALVES

- A. Twin disc, Class 125 spring actuated designed to be installed with gaskets between two standard Class 125 flanges. 200 PSI, cast iron body, aluminum bronze disc. Nibco W-920-W.
- B. Check Valve: PPS coated ductile iron body, ASTM A536, aluminum bronze nonslamming disc, stainless steel spring and shaft. Rubber seat for intended service.

PART 3 - EXECUTION

3.1 GENERAL VALVE INSTALLATION REQUIREMENTS

- A. Prepare valves for shipping as follows:
 - 1. Protect internal parts against rust and corrosion.
 - 2. Protect threads, flange faces, grooves, and weld ends.
 - 3. Set angle valves closed to prevent rattling.
 - 4. Set ball open to minimize exposure of functional surfaces.
 - 5. Block check valves in either closed or open position.
- B. Inspect the shipping container before unpacking to look for damage that could have occurred during transport, and report it to the transportation company immediately. After visual inspection, remove the valve from the shipping container. Make sure the faces are free of any scratches and that there is not any obvious damage to the actuator assembly or valve body.
- C. Make sure to note the valve's model number during the unpacking process. The model number will need to be provided when purchasing replacement parts.
- D. Use the following precautions during storage:
 - 1. Maintain valve end protection.
 - 2. Store valves indoors and maintain at higher than ambient dew-point temperature. If outdoor storage is necessary, store valves off the ground in watertight enclosures.
- E. Use sling to handle large valves; rig sling to avoid damage to exposed parts. Do not use handwheels or stems as lifting or rigging points.
- F. Do not attempt to repair defective valves; replace with new valves.
- G. Install valves per manufacturer's recommendations.

- H. Install valves where required for proper operation of piping and equipment, including valves in branch lines where necessary to isolate sections of piping. Locate valves so as to be accessible and so that separate support can be provided when necessary.
- I. Purge and clean piping to be connected to valve.
- J. Install valves with stems pointed up, in vertical position where possible, but in no case with stems pointed downward from horizontal plane unless unavoidable. Install valve drains with hose end adapter and cap on chain for each valve that must be installed with stem below horizontal plane. Ensure installation provides full stem movement.
- K. Determine that the valve and its piping is adequately supported when installed. If a valve is not adequately supported, this could prevent the valve from operating and sealing correctly. Be sure that mating flanges are in line and parallel to minimize straining on joints and valve body.
- L. Insulation: Where insulation is indicated, install extended stem valves, arranged in proper manner to receive insulation.
- M. Mechanical Actuators: Install with chain operators where indicated. Extend chains to 5-feet above floor and hook to clips to clear aisle passage.
- N. Stem Selection: Outside screw and yoke stems, except provide inside screw, nonrising stem where space prevents full opening of OS&Y valves.
- O. Seats: Renewable seats, except where otherwise indicated.
- P. When soldering, use paste flux that is approved by the manufacturer for use with lead-free alloys.
- Q. Boiler isolation valves with adjustable packing gland per CSD-1 requirements.
- R. Valve Adjusting and Cleaning:
 - 1. Inspect valves for leaks. Adjust or replace packing to stop leaks. Replace valve if leak persists.
 - 2. Valve Identification: Tag valves per Section 23 05 53, Identification for HVAC Piping, Ductwork and Equipment.
- S. General Requirements for Valve Applications:
 - 1. If valve applications are not indicated, use the following:
 - a. Shutoff Service: Ball valves.
 - b. Throttling Service: Balancing valves.
 - c. Pump-Discharge Check Valves:
 - 1) 2 Inches and Smaller: Swing or spring-loaded lift check valves with bronze disc.
 - 2) 2-1/2 Inches and Larger: Swing check valves with lever and weight or with spring or wafer - seat check valves.
 - d. Provide isolation valve, check valve, automatic flow control valve and balancing valve on discharge side of pumps where indicated. Combination triple duty valves not allowed. Provide isolation valve and strainer on suction side of pump.

2. If valves with specified SWP classes or CWP ratings are not available, the same types of valves with higher SWP classes or CWP ratings may be substituted.
3. Valves, except wafer types, with the following end connections.
 - a. For Copper Tubing 2 Inches and Smaller: Threaded ends.
 - b. For Copper Tubing 2-1/2 Inches to NPS 4 Inches: Flanged ends.
 - c. For Copper Tubing 5 Inches and Larger: Flanged ends.
 - d. For Steel Piping 2 Inches and Smaller: Threaded ends.
 - e. For Steel Piping 2-1/2 inches to NPS 4 Inches: Flanged ends.
 - f. For Steel Piping 5 Inches and Larger: Flanged ends.
 - g. For Grooved-End Copper Tubing and Steel Piping: Valve ends may be grooved.

3.2 BALANCING VALVE INSTALLATION

- A. See General Installation Requirements above.
- B. Install with flow in the direction of the arrow on the valve body and install at least five pipe diameters downstream from any fitting, and at least ten pipe diameters downstream from any pump. Two pipe diameters downstream from the balancing valve should be free of any fittings. When installed, easy and unobstructed access to the valve handwheel and metering ports for adjustment and measurement are to be provided. Install devices in accordance with manufacturer's recommendations to automatically balance flow in piping loops as indicated.
- C. For venturi valves less than 1-1/2-inch pipe size, provide valve sized for flow to coil. Provide transitions on both inlet and outlet of valve if valve is less than line size.

3.3 BALL VALVE INSTALLATION

- A. See General Installation Requirements above.

3.4 BUTTERFLY VALVE INSTALLATION

- A. See General Installation Requirements above.

3.5 SWING CHECK VALVE INSTALLATION

- A. See General Installation Requirements above.
- B. Install in the horizontal or vertical position with upward flow. Install for proper direction of flow. Install with minimum three pipe diameters of straight pipe upstream of valve.

3.6 WAFER CHECK VALVE INSTALLATION

- A. See General Installation Requirements above.
- B. Install between two flanges in horizontal or vertical position, position for proper direction of flow.

END OF SECTION

SECTION 23 0529 - HANGERS AND SUPPORTS FOR HVAC PIPING, DUCTWORK AND EQUIPMENT

PART 1 - GENERAL

1.1 SUMMARY

A. Work Included:

1. Hangers and Supports for HVAC Piping, Ductwork and Equipment
2. Wall and Floor Sleeves
3. Building Attachments
4. Flashing
5. Miscellaneous Metal and Materials

1.2 RELATED SECTIONS

- A. Contents of Division 23, HVAC and Division 01, General Requirements apply to this Section.

1.3 REFERENCES AND STANDARDS

- A. References and Standards as required by Section 23 00 00, HVAC Basic Requirements and Division 01, General Requirements.

B. In addition, meet the following:

1. ASCE 7-10, Minimum Design Loads for Buildings and Other Structures.
2. Terminology: As defined in MSS SP-90 "Guidelines on Terminology for Pipe Hangers and Supports".
3. Install ductwork and piping per SMACNA's requirements.
4. Hanger spacing installation and attachment to meet all manufacturer's requirements and MSS SP-58.

1.4 SUBMITTALS

- A. Submittals as required by Section 23 00 00, HVAC Basic Requirements and Division 01, General Requirements.

1.5 QUALITY ASSURANCE

- A. Quality assurance as required by Section 23 00 00, HVAC Basic Requirements and Division 01, General Requirements.

B. In addition, meet the following:

1. Welding:
 - a. Qualify processes and operators according to ASME Boiler and Pressure Vessel Code: Section IX, "Welding and Brazing Qualifications".
2. Welding for Hangers:
 - a. Qualify procedures and personnel according to AWS D9.1, Sheet Metal Welding Code for duct joint and seam welding.
3. Engineering Responsibility:

- a. Design and preparation of Shop Drawings and calculations for each multiple pipe support, trapeze, duct support equipment hangers/supports, and seismic restraint by a qualified Structural Professional Engineer.
 - 1) Professional Engineer Qualifications: A professional engineer who is legally qualified to practice in jurisdiction where project is located and who is experienced in providing engineering services of the kind indicated. Engineering services are defined as those performed for installations of hangers and supports that are similar to those indicated for this Project in material, design, and extent.
4. Manufacturers regularly engaged in the manufacture of bolted metal framing support systems, whose products have been in satisfactory use in similar service for not less than 10 years.
5. Support systems to be supplied by a single manufacturer.

1.6 WARRANTY

- A. Warranty of materials and workmanship as required by Section 23 00 00, HVAC Basic Requirements and Division 01, General Requirements.

1.7 PERFORMANCE REQUIREMENTS

- A. Provide pipe, ductwork and equipment hangers and supports in accordance with the following:
 1. When supports, and anchorages, and restraints for equipment, and supports, anchorages, and restraints for conduit, piping, and ductwork are not shown on the Drawings, the contractor is responsible for their design.
 2. Connections to structural framing not to introduce twisting, torsion, or lateral bending in the framing members. Provide supplementary steel as required.
- B. Engineered Support Systems:
 1. Support frames such as pipe racks or stanchions for piping, ductwork, and equipment which provide support from below.
 2. Equipment, ductwork and piping support frame anchorage to supporting slab or structure.
- C. Provide channel support systems, for piping to support multiple pipes capable of supporting combined weight of supported systems, system contents, and test water.
- D. Provide heavy-duty steel trapezes for piping to support multiple pipes capable of supporting combined weight of supported systems, system contents, and test water.
- E. Provide restraint hangers and supports for piping, ductwork and equipment. See Section 23 0548, Vibration Controls for HVAC Equipment.
- F. Obtain approval from AHJ for restraint hanger and support system to be installed for piping and equipment. See Section 23 0548, Vibration Controls for HVAC Equipment.

PART 2 - PRODUCTS

2.1 MANUFACTURERS

- A. Hangers and Supports for HVAC Piping, Ductwork and Equipment:
 1. Anvil International

2. B-Line Systems, Incorporated
3. Erico Company, Incorporated
4. Nelson-Olsen Incorporated
5. Rilco Manufacturing Company, Incorporated
6. Snappitz Thermal Pipe Shield Manufacturing
7. Unistrut Corporation

B. Wall and Floor Sleeves:

1. Thunderline Corporation "Link Seal".
2. Or approved equivalent.

C. Building Attachments:

1. Anchor-It
2. Gunnebo Fastening Corporation
3. Hilti Corporation
4. ITW Ramset/Red Head
5. Masterset Fastening Systems, Incorporated

2.2 HANGERS AND SUPPORTS FOR HVAC PIPING, DUCTWORK AND EQUIPMENT

A. Hanger Rods: Hanger rods continuously threaded or threaded ends only in concealed spaces and threaded ends only in exposed spaces; finish electro-galvanized or cadmium-plated in concealed spaces and prime painted in exposed spaces; sizes per MSS.

B. Hanger Rod Couplings: Anvil Figure 136, B-Line Figure B3220, or approved equivalent; malleable iron rod coupling with elongated center sight gap for visual inspection; to have same finish as hanger rods.

C. Channel Hanging System:

1. Framing members No. 12 gauge formed steel channels, 1-5/8-inch square, conforming to ASTM A570 GR33, one side of channel to have a continuous slot within turned lips; framing nut with grooves and spring 1/2-inch size, conforming to ASTM 675 GR60; screws conforming to ASTM A307; fittings conforming to ASTM A575; parts enamel painted or electro-galvanized.
2. Concrete Inserts: Malleable iron body, hot dipped galvanized finish. Lateral adjustment. MSS Type 18.

D. Continuous Concrete Insert: Steel construction, minimum 12 gauge. Electrogalvanized finish. Pipe clamps and insert nuts to match.

E. Pipe Hangers:

1. Pipe Rings for Hanger Rods:
 - a. Pipe Sizes 2-inches and Smaller: Adjustable swivel ring hanger, UL listed. Erico 100 or 101, Anvil Figures 69 or 104, or approved equivalent.
 - b. Pipe Sizes 2-1/2-inches and Larger: Clevis type hangers with adjustable nuts on rod, UL listed. Anvil figure 260, Erico 400, or approved equivalent.
 - c. Pipe hangers to have same finish as hanger rods.

F. Pipe Saddles and Shields:

1. Factory fabricated saddles or shields under piping hangers and supports for insulated piping.
 2. Size saddles and shields for exact fit to mate with pipe insulation. 1/2 round, 18 gauge, minimum 12-inches in length (4-inch pipe and larger to be three times longer than pipe diameter).
- G. Riser Clamps: Steel, UL listed. MSS Type 8. Erico 510 or 511. Copper coated; Erico 368.
- H. Pipe Slides: Anvil, reinforced Teflon slide material (3/32-inch minimum thickness) bonded to steel; highly finished steel or stainless steel contact surfaces to resist corrosion; 60-80 PSI maximum active contact surface loading; steel parts 3/16-inch minimum thickness; attachment to pipe and framing by welding.
- I. Pipe Guides:
1. Furnish and install pipe guides on continuous runs where pipe alignment must be maintained. Minimum two on each side of expansion joints, spaced per manufacturer's recommendations for pipe size. Fasten guides securely to pipe and structure. Contact with chilled water pipe not to permit heat to be transferred in sufficient quantity to cause condensation on any surface.
 2. Furnish and install guides approximately four pipe diameters (first guide) and 14 diameters (second guide) away from each end of expansion joints. Guides are not to be used as supports and are in addition to other pipe hangers and supports.
- J. Pipe Roller Hangers: Adjustable roller hanger. Black steel yoke, cast iron roller. MSS Type 41.
- K. Below Ground Pipe Supports:
1. Pipe Hangers All Sizes: Adjustable Clevis type, Federal Specification WW-H-171 (Type 1), UL listed, stainless steel Type 304. MSS Type 1. Erico 406.
 2. Rod: 5/8-inch stainless steel Type 18-8.
 3. Eyebolt: Stainless steel Type 18-8.
 4. Nuts and Washers: Stainless steel Type 18-8.
- L. Thermal Hanger Shield Inserts:
1. 100-PSI (690-kPa) minimum compressive strength calcium silicate insulation, encased in sheet metal shield or polyisocyanurate rigid foam exceeding the load bearing weight of the pipe at the hanger point with a PVC vapor barrier.
 2. Material for Cold Piping: Water-repellent-treated, ASTM C533, Type I calcium silicate with vapor barrier or polyisocyanurate rigid foam with a PVC vapor barrier.
 3. Material for Hot Piping: Water-repellent-treated ASTM C533, Type 1 calcium silicate or polyisocyanurate rigid foam with a PVC vapor barrier.
 4. For Trapeze or Clamped System: Insert and shield cover entire circumference of pipe.
 5. For Clevis or Band Hanger: Insert and shield cover lower 180 degrees of pipe.
 6. Insert Length: Extend 2-inches beyond sheet metal shield for piping operating below ambient air temperature.
 7. Thermal Hanger Shield Insulation Operating Temperature: Meet or exceed fluid temperature in pipe.
- M. Freestanding Roof Supports: Polyethylene high-density UV resistant quick "pipe" block with foam pad.

2.3 WALL AND FLOOR SLEEVES

- A. Below Grade or High Water Table Areas:
 - 1. "Link-Seal" Pipe Sleeves: Neoprene gasket links bolted together around an interior sleeve forming a watertight seal.
 - 2. Provide Type S unless otherwise noted.
- B. Pre-Engineered Firestop Pipe Penetration Systems: UL listed assemblies for maintaining fire rating of piping penetrations through fire-rated assemblies. Comply with ASTM E814.
- C. Fabricated Accessories:
 - 1. Steel Pipe Sleeves: Fabricate from Schedule 40 black or galvanized steel pipe. Remove end burrs by grinding.
 - 2. Sheet Metal Pipe Sleeves: Fabricate from G-90 galvanized sheets closed with lock-seam joints. Provide the following minimum gauges for the sizes indicated:
 - a. Sleeve Size 4-inches in Diameter and Smaller: 18 gauge.
 - b. Sleeve Sizes 5-6-inches: 16 gauge.
 - c. Sleeve Sizes 7-inches and Larger: 14 gauge.
 - d. Fire-Rated Safing Material.
 - 1) Rockwool Insulation: Complying with FS-HH-I-558, Form A, Class IV, 6 pounds per cubic foot density with melting point of 1985 degrees F and K value of 0.24 at 75 degrees F.
 - 2) Calcium Silicate Insulation: Noncombustible, complying with FS-HH-I-523, Type II, suitable for 100 degrees F to 1200 degrees F service with K value of 0.40 at 150 degrees F.

2.4 BUILDING ATTACHMENTS

- A. Beam Clamps:
 - 1. MSS Type 19 and 23, wide throat, with retaining clip.
 - 2. Universal Side Beam Clamp: MSS Type 20.
- B. Powder-Actuated Drive Pin Fasteners: Powder actuated type, drive pin attachments with pull-out and shear capacities appropriate for supported loads and building materials where used.
- C. Anchor Bolts:
 - 1. Anchor supports to existing masonry, block and tile walls per anchoring system manufacturer's recommendations or as modified by project structural engineer. Insert-type attachments with pull-out and shear capacities appropriate for supported loads and building materials where used.
 - 2. Anchor Bolts (Cast-In-Place): Steel bolts, ASTM A307. Nuts to conform to ASTM A194. Design values for shear and tension not more than 80 percent of the allowable listed loads.
 - 3. Anchor (Expansion) Bolts: Carbon steel to ASTM A307; nut to conform to ASTM A194; drilled-in type. Design values for shear and tension not more than 80 percent of the allowable listed loads.
 - 4. Anchor (Adhesive) Bolts: Consisting of two-part adhesive cartridge and zinc-plated Type A307 steel anchor bolt rod assembly with ASTM A194 nut.

2.5 FLASHING

- A. Steel Flashing: 26 gauge galvanized steel.
- B. Safes: 8 mil thick neoprene.
- C. Caps: Steel, 22 gauge minimum, 16 gauge at fire-resistant structures.

2.6 MISCELLANEOUS METAL AND MATERIALS

- A. General:
 - 1. Provide miscellaneous metal items specified, including materials, fabrication, fastenings and accessories required for finished installation, where indicated on drawings or otherwise not shown on drawings that are necessary for completion of the project. Contractor is responsible for their design.
 - 2. Fabricate miscellaneous units to size shapes and profiles indicated or, if not indicated, of required dimensions to receive adjacent other work to be retained by framing. Except as otherwise shown, fabricate from structural steel shapes and plates and steel bars, of welded construction using mitered joints for field connection. Cut, drill and tap units to receive hardware and similar items.
- B. Structural Shapes: Where miscellaneous metal items are needed to be fabricated from structural steel shapes and plates, provide members constructed of steel conforming with requirements of ASTM A36 or approved equivalent.
- C. Steel Pipe: Provide seamless steel pipe conforming to requirements of ASTM A53, Type S, Grade A, or Grade B. Weight and size required as specified.
- D. Fasteners: Provide fasteners of types as required for assembly and installation of fabricated items; surface-applied fasteners are specified elsewhere.
- E. Bolts: Low carbon steel externally and internally threaded fasteners conforming with requirements of ASTM A307; include necessary nuts and plain hardened washers. For structural steel elements supporting mechanical material or equipment from building structural members or connection thereto, use fasteners conforming to ASTM A325.
- F. Miscellaneous Materials: Provide incidental accessory materials, tools, methods, and equipment required for fabrication.
- G. Provide hot dipped galvanized components for items exposed to weather. Cold galvanize field-welded joints and components. Use materials compatible with system being supported (i.e. aluminum for aluminum ductwork, stainless steel for stainless steel ductwork).
- H. Use straps, threshold rods and wire with sizes required by SMACNA to support ductwork.
- I. Grout:
 - 1. ASTM C1107, Grade B, factory mixed and packaged, nonshrink and nonmetallic, dry, hydraulic-cement grout.
 - 2. Characteristics: Post hardening and volume adjusting; recommended for both interior and exterior applications.

3. Properties: Nonstaining, noncorrosive, and non gaseous.
4. Design Mix: 5000-PSI (34.5-MPa), 28-day compressive strength.

PART 3 - EXECUTION

3.1 GENERAL INSTALLATION REQUIREMENTS

- A. Verify building materials to have hangers and attachments affixed in accordance with hangers to be used. Provide supporting calculations.
- B. Examine Drawings and coordinate for verification of exact locations of fire and smoke rated walls, partitions, floors and other assemblies. Indicate, by shading and labeling on Record Drawings such locations and label as "1-Hour Wall", "2-Hour Fire/Smoke Barrier", and the like. Determine proper locations for piping penetrations. Set sleeves in place in new floors, walls or roofs prior to concrete pour or grouting.
- C. Install hangers, supports, anchors and sleeves after required building structural work has been completed in areas where the work is to be installed. Coordinate proper placement of inserts, anchors and other building structural attachments.
- D. Equipment Clearances: Do not route ductwork, equipment, or piping through electrical rooms, transformer vaults, elevator equipment rooms, IT rooms, MPOE rooms, or other electrical or electronic equipment spaces and enclosures and the like. Within equipment rooms, provide minimum 3-feet lateral clearance from all sides of electric switchgear panels. Do not route ductwork, equipment, or piping above any electric power or lighting panel, switchgear, or similar electric device. Coordinate with Electrical and coordinate exact ductwork, equipment or pipe routing to provide proper clearance with such items.

3.2 HANGERS AND SUPPORTS FOR HVAC PIPING, DUCTWORK AND EQUIPMENT

- A. Hang rectangular sheet-metal ducts with a cross sectional area of less than 7 SF with galvanized strips of No. 16 USS gauge steel 1-inch wide, and larger ducts with steel angles and adjustable hanger rods similar to piping hangers. Support at a maximum of 8-feet on center.
- B. Support horizontal ducts within 24-inches of each elbow and within 48-inches of each branch intersection.
- C. Design hangers and supports to allow for expansion and contraction.
- D. Provide aluminum supports for aluminum ductwork.
- E. Provide stainless steel supports for stainless steel ductwork.
- F. Support vertical ducts at maximum intervals of 16-feet and at each floor.
- G. Install upper attachments to structures with an allowable load not exceeding one-fourth of failure (proof-test) load.
- H. Install flexible ductwork per the more stringent of SMACNA HVAC Duct Construction Standards or the following:
 1. Support horizontal duct runs at not more than 4 feet intervals.

2. Support vertical risers at not more than 6 feet intervals.
 3. Limit sag between support hangers to 1/2-inch per foot of spacing support.
 4. Supports shall be rigid and shall be not less than 1.5-inches wide at point of contact with the duct surface.
 5. Duct bends shall be not less than 1.5 duct diameter bend radius.
- I. Use double nuts and lock washers on threaded rod supports.
- J. Floor supports in mechanical rooms to be elevated 1-inch above finish floor and void space filled with masonry grout.
- K. Anchor ducts securely to building in such a manner as to prevent transmission of vibration to structure. Do not connect duct hanger straps directly to roof deck. Do not support ducts from other ducts, piping or equipment.
- L. Attach strap hangers installed flush with end of sheet-metal duct run to duct with sheet-metal screws.
- M. Construct exterior ductwork or ductwork which is otherwise exposed to weather watertight and slope 1/4-inch per foot to avoid standing water.
- N. Exposed ductwork hung in clean areas such as sanitary areas, pharmaceutical areas, wash down areas or food process areas to be installed using double end, food grade trapeze hanger rods suitable for use with food grade strut.
- O. Channel Support System Installation:
 1. Arrange for grouping of parallel runs of piping and support together on field-assembled channel systems.
 2. Field assemble and install according to manufacturer's written instructions.
- P. Install hangers and supports complete with necessary inserts, bolts, rods, nuts, washers, and other accessories.
- Q. Install hangers and supports to allow controlled thermal and seismic movement of piping systems, to permit freedom of movement between pipe anchors, and to facilitate action of expansion joints, expansion loops, expansion bends, and similar units.
- R. Load Distribution: Install hangers and supports so that piping live and dead loads and stresses from movement will not be transmitted to connected equipment.
- S. Adjust hangers so as to distribute loads equally on attachments. Provide grout under supports to bring piping, ductwork and equipment to proper level and elevations.
- T. Prime paint ferrous nongalvanized hangers, accessories, and supplementary steel which are not factory painted.
- U. Horizontal Piping Hangers and Supports; Horizontal and Vertical Piping, and Hanger Rod Attachments:
 1. Factory fabricated horizontal piping hangers and supports complying with MSS SP-58, to suit piping systems and in accordance with manufacturer's published product information.
 2. Use only one type by one manufacturer for each piping service.

3. Select size of hangers and supports to exactly fit pipe size for bare piping, and to exactly fit around piping insulation with saddle or shield for insulated piping.
 4. Pipe support spacing (pipe supported in ceiling or floor-supported) to meet latest applicable Code and manufacturer's requirements.
 5. Provide copper-plated hangers and supports for uninsulated copper piping systems.
- V. Plumber's Tape not permitted as pipe hangers or pipe straps.
- W. Comply with MSS SP-58. Install hangers, supports, clamps, and attachments as required to properly support piping from building structure. For horizontally hung grooved-end piping, provide a minimum of 2 hangers per pipe section.
- X. Pipe Ring Diameters:
1. Uninsulated and Insulated Pipe, Except Where Oversized Pipe Rings are Specified: Ring inner diameter to suit pipe outer diameter.
 2. Insulated Piping Where Oversized Pipe Rings are Specified and Vibration Isolating Sleeves: Ring inner diameter to suit outer diameter of insulation or sleeve.
- Y. Oversize Pipe Rings: Provide oversize pipe rings of 2-inch and larger size.
- Z. Pipe Support Brackets: Support pipe with pipe slides.
- AA. Steel Backing in Walls: Provide steel backing in walls to support fixtures and piping hung from steel stud walls.
- AB. Pipe Guides:
1. Install on continuous runs where pipe alignment must be maintained. Minimum two on each side of expansion joints, spaced per manufacturer's recommendations for pipe size. Fasten guides to pipe structure. Contact with chilled water pipe does not permit heat to be transferred in sufficient quantity to cause condensation on any surface.
 2. Install approximately four pipe diameters (first guide) and 14 diameters (second guide) away from each end of expansion joints. Do not use as supports. Provide in addition to other required pipe hangers and supports.
- AC. Heavy-Duty Steel Trapeze Installation:
1. Arrange for grouping of parallel runs of horizontal piping and support together on field fabricated, heavy-duty trapezes.
 2. Pipes of Various Sizes: Support together and space trapezes for smallest pipe size or install intermediate supports for smaller diameter pipes as specified above for individual pipe hangers.
 3. Field fabricate from ASTM A 36/A 36M, steel shapes selected for loads being supported. Weld steel according to AWS D-1.1.
- AD. Group parallel runs of horizontal piping to be supported together on trapeze-type hangers. Maximum spacings: MSS SP-58.
- AE. Where piping of various sizes is to be supported together by trapeze hangers, space hangers for smallest pipe size or install intermediate supports for smaller diameter pipe.
- AF. Do not support piping from other piping.

- AG. Fire protection piping will be supported independently of other piping.
- AH. Prevent electrolysis in support of copper tubing by use of hangers and supports which are copper plated.
- AI. Pipe Slopes: Install hangers and supports to provide indicated pipe slopes and so maximum pipe deflections allowed by ASME B31.9, "Building Services Piping" is not exceeded.
- AJ. Insulated Piping:
1. Attach clamps and spacers to piping.
 - a. Piping Operating Above Ambient Air Temperature: Clamp may project through insulation.
 - b. Piping Operating Below Ambient Air Temperature: Use thermal-hanger shield insert with clamp sized to match OD of insert.
 2. Do not exceed pipe stress limits according to ASME B31.9.
 3. Install MSS SP-58, Type 39 protection saddles, if insulation without vapor barrier is indicated. Fill interior voids with insulation that matches adjoining insulation.
 4. Install MSS SP-58, Type 40 protective shields on cold piping with vapor barrier. Shields to span arc of 180 degrees.
 5. Option: Thermal-hanger shield inserts may be used. Include steel weight-distribution plate for pipe NPS 4 (DN100) and larger if pipe is installed on rollers.
 6. Shield Dimensions for Pipe, not less than the following:
 - a. NPS 1/4 to NPS 3-1/2 (DN8 to DN 90): 12-inches long and 0.048-inch thick.
 - b. NPS 4 (DN100): 12-inches long and 0.06-inch thick.
 - c. NPS 5 and NPS 6 (DN125 and DN150): 18-inches long and 0.06-inch thick.
 - d. NPS 8 to NPS 14 (DN200 to DN350): 24-inches long and 0.075-inch thick.
 - e. NPS 16 to NPS 24 (DN400 to DN600): 24-inches long and 0.105-inch thick.
 7. Pipes NPS 8 (DN200) and Larger: Include wood inserts.
 - a. Insert Material: Length at least as long as protective shield.
 8. Thermal-Hanger Shields: Install with insulation same thickness as piping insulation.
- AK. Pipe Anchors: Provide anchors to fasten piping which is subject to expansion and contraction, and adjacent to equipment to prevent loading high forces onto the equipment.
- AL. Pipe Curb Assemblies:
1. Provide prefabricated units for roof membrane and insulation penetrations related to equipment. Coordinate with roofing system. Set supports on the structural deck. Do not set supports on insulation or roofing. Provide level supports by prefabricated pitch built into the curb.
 2. Provide for piping and electrical conduit which penetrates the structural roof deck to service equipment above the roof level (i.e., piping, electrical power and control wiring). Meet requirements of roof warranty.
- AM. Escutcheon Plates: Install around horizontal and vertical piping at visible penetrations through walls, partitions, floors, or ceilings, including penetrations through closets, through below ceiling corridor walls, and through equipment room walls and floors.
- AN. Vertical Piping:

1. Support with U-clamps fastened to wall to hold piping away from wall unless otherwise approved.
 2. Riser clamps to be directly under fitting or welded to pipe.
 - a. Riser to be supported at each floor of penetration.
 - b. Provide structural steel supports at the base of pipe risers. Size supports to carry forces exerted by piping system when in operation.
- AO. Piping above roof to be supported with freestanding roof pipe supports unless detailed otherwise.

3.3 WALL AND FLOOR SLEEVES

- A. "Link-Seal" Pipe Sleeves: Install at floor/below grade piping penetrations. Provide manufacturer's sleeve appropriate to seal type for pre-cast penetrations.
- B. Fabricated Pipe Sleeves:
1. Provide either steel or sheet metal pipe sleeves accurately centered around pipe routes. Size such that piping and insulation, if any, will have free movement within the sleeve, including allowance for thermal expansion. Sleeve diameter to be determined by local seismic clearance requirements, and by waterproofing requirements.
 2. Length: Equal to thickness of construction penetrated, except extend floor sleeves 1-inch above floor finish.
 3. Provide temporary support of sleeves during placement in concrete and other work around sleeves. Provide temporary end closures to prevent concrete and other materials from entering pipe sleeves.
 4. Seal each end airtight with a resilient nonhardening sealer, UL listed, fire rated ASTM 814.
- C. Installation of metallic or plastic piping penetrations through non fire-rated walls and partitions and through smoke-rated walls and partitions:
1. Install fabricated pipe sleeve.
 2. After installation of sleeve and piping, tightly pack entire annular void between piping or piping insulation and sleeve identification with specified material.
 3. Seal each end airtight with a resilient nonhardening UL listed fire resistant ASTM 814.
- D. Piping Penetrations Through Fire-Rated (One to Three Hour) Assemblies:
1. Select and install pre-engineered pipe penetration system in accordance with the UL listing and manufacturer's recommendation.
 2. Provide proper sizing when providing sleeves or core-drilled holes to accommodate the penetration. Firestop voids between sleeve or core-drilled hole and pipe passing through to meet the requirements of ASTM E814.

3.4 BUILDING ATTACHMENTS

- A. Factory fabricated attachments complying with MSS SP-58, selected to suit building substructure conditions and in accordance manufacturer's published product information.
- B. Select size of building attachments to suit hanger rods.
- C. Space attachments within maximum piping span length indicated in MSS SP-58.

- D. Install building attachments within concrete slabs or attach to structural steel or wood. Install additional building attachments where support is required for additional concentrated loads, including valves, flanges, guides, strainers, expansion joints, and at changes in direction of piping.
- E. Attachment to Wood Structure: Anvil side beam bracket Figure 202 for attachment to wooden beam or approved attachment for a wood structure.
- F. Install mechanical-anchor fasteners in concrete after concrete is placed and completely cured. Install fasteners according to manufacturer's written instructions.
- G. Install concrete inserts before concrete is placed; fasten inserts to forms. Where concrete with compressive strength less than 2500 PSI is indicated, install reinforcing bars through openings at top in inserts.
- H. Install powder-actuated drive-pin fasteners in concrete after concrete is placed and completely cured. Use operators that are licensed by powder-actuated tool manufacturer. Install fasteners according to powder-actuated tool manufacturer's operating manual. Test powder-actuated insert attachments with a minimum load of 100 pounds.
- I. Do not use powder-actuated concrete fasteners for lightweight aggregate concretes or for slabs less than 4-inches thick.
- J. Bolting: Provide bored, drilled or reamed holes for bolting to miscellaneous structural metals, frames or for mounts or supports. Flame cut, punched or hand sawn holes will not be accepted.
- K. Anchor Bolts:
 - 1. Install anchor bolts for mechanical equipment, piping and ductwork as required. Tightly fit and clamp base-supported equipment anchor bolts at equipment support points. Provide locknuts where equipment, piping and ductwork are hung.
 - 2. Anchor Bolts (Cast-In-Place): Embed anchor bolts in new cast-in-place concrete to anchor equipment. Install a pipe sleeve around the anchor bolt for adjustment of the top 1/3 of the bolt embedment; sizes and patterns to suit the installation conditions of the equipment to be anchored.

3.5 FLASHING

- A. Flash and counterflash where piping, ductwork and equipment passes through weather or waterproofed walls, floors, and roofs.
- B. Provide 12-inch minimum height curbs for roof-mounted mechanical equipment. Flash and counter flash with galvanized steel, soldered and waterproofed.

3.6 MISCELLANEOUS METAL AND MATERIALS

- A. General: Verify dimensions prior to fabrication. Form metal items to accurate sizes and configurations as indicated on drawings and otherwise required for proper installation; make with lines straight and angles sharp, clean and true; drill, countersink, tap, and otherwise prepare items for connections with work of other trades, as required. Fabricate to detail of structural shapes, plates and bars; weld joints where practicable; provide bolts and other connection

devices required. Include anchorages; clip angles, sleeves, anchor plates, and similar devices. Hot dipped galvanize after fabrication items installed in exterior locations. Set accurately in position as required and anchor securely to building construction. Construct items with joints formed for strength and rigidity, accurately machining for proper fit; where exposed to weather, form to exclude water.

B. Finishes:

1. Ferrous Metal: After fabrication, but before erection, clean surfaces by mechanical or chemical methods to remove rust, scale, oil, corrosion, or other substances detrimental to bonding of subsequently applied protective coatings. For metal items exposed to weather or moisture, galvanize in manner to obtain G90 zinc coating in accordance with ASTM A123. Provide other non-galvanized ferrous metal with 1 coat of approved rust-resisting paint primer, in manner to obtain not less than 1.0 mil dry film thickness. Touch-up damaged areas in primer with same material, before installation. Apply zinc coatings and paint primers uniformly and smoothly; leave ready for finish painting as specified elsewhere.
2. Metal in Contact with Concrete, Masonry and Other Dissimilar Materials: Where metal items are to be erected in contact with dissimilar materials, provide contact surfaces with coating of an approved zinc-chromate primer in manner to obtain not less than 1.0 mil dry film thickness, in addition to other coatings specified in these specifications.
3. For Galvanized Surfaces: Clean field welds, bolted connections, and abraded areas and apply galvanizing repair paint to comply with ASTM A780.

- C. Coordinate and furnish anchorages, setting drawings, diagrams, templates, instructions, and directions for installation of anchorages, such as concrete inserts, sleeves, anchor bolts and miscellaneous items having integral anchors, which are to be embedded in concrete or masonry construction. Coordinate delivery of such items to project site.
- D. Fastening to In-Place Construction: Provide anchorage devices and fasteners where necessary for securing miscellaneous metal fabrications to in-place construction; including, threaded fasteners for concrete and masonry inserts, toggle bolts, through-bolts, lag bolts, wood screws and other connectors as required. Avoid cutting concrete reinforcing when drilling for inserts. Reference structural drawings and reinforcing shop drawings and determine locations of stirrups prior to drilling into concrete.
- E. Cutting, Fitting and Placement: Perform cutting, drilling and fitting required for installation of miscellaneous metal fabrications. Set work accurately in location, alignment and elevation, plumb, level, true and free of rack, measured from established lines and levels. Provide temporary bracing or anchors in formwork for items, which are to be built into concrete masonry or similar construction.
- F. Field Welding: Comply with AWS Code for procedures of manual shielded metal-arc welding, appearance and quality of welds made, and methods used in correcting welding work.
- G. Setting Loose Plates: Clean concrete and masonry bearing surfaces of any bond reducing materials, and roughen to improve bond to surfaces. Clean bottom surface of bearing plates.
- H. Set loose leveling and bearing plates on wedges, or other adjustable devices. After the bearing members have been positioned and plumbed, tighten the anchor bolts. Do not remove wedges or shims, but if protruding, cut-off flush with edge of the bearing plate before packing with grout.

Use metallic non-shrink grout in concealed locations where not exposed to moisture; use non-metallic non-shrink grout in exposed locations, unless otherwise indicated.

- I. Pack grout solidly between bearing surfaces and plates to ensure that no voids remain.
- J. Cut, drill, and fit miscellaneous metal fabrications for heavy-duty steel trapezes and equipment supports.
- K. Fit exposed connections together to form hairline joints. Field-weld connections that cannot be shop-welded because of shipping size limitations.
- L. Field Welding: Comply with AWS D1.1 procedures for shielded metal arc welding, appearance and quality of welds, and methods used in correcting welding work, and with the following:
 - 1. Use materials and methods that minimize distortion and develop strength and corrosion resistance of base metals.
 - 2. Obtain fusion without undercut or overlap.
 - 3. Remove welding flux immediately.
 - 4. Finish welds at exposed connections so no roughness shows after finishing and contours of welded surfaces match adjacent contours.
- M. Provide galvanized components for items exposed to weather.

3.7 FIRE RATED SUPPORTS

- A. Provide fire rated support as required by Codes.

END OF SECTION

SECTION 23 0548 - VIBRATION CONTROLS FOR HVAC EQUIPMENT

PART 1 - GENERAL

1.1 SUMMARY

A. Work Included:

1. Vibration Isolation
2. Factory Finishes

B. General:

1. Vibration isolation for mechanical ductwork, piping and equipment.
2. Special inspections for systems.

C. Scope of Work:

1. Vibration isolation restraint of new equipment and systems within project boundary defined in architectural drawings.
2. Vibration isolation restraint of new equipment and systems in existing buildings to points of connection with existing systems.

1.2 RELATED SECTIONS

- A. Contents of Division 23, HVAC and Division 01, General Requirements apply to this Section.

1.3 REFERENCES AND STANDARDS

- A. References and Standards as required by Section 23 00 00, HVAC Basic Requirements and Division 01, General Requirements.

1.4 SUBMITTALS

- A. Submittals as required by Section 23 00 00, HVAC Basic Requirements and Division 01, General Requirements.

B. In addition, provide:

1. Vibration Isolation:
 - a. Product Data: Provide catalog data indicating size, type, load and deflection of each isolator; and percent of vibration transmitted based on lowest disturbing frequency of equipment.
 - b. Shop Drawings: Showing complete details of construction for steel and concrete bases including:
 - 1) Fabrication, including anchorages and attachments to structure and to supported equipment. Include auxiliary motor slides and rails, base weights, equipment static loads, power transmission, component misalignment and cantilever loads.
 - 2) Equipment mounting holes.
 - 3) Dimensions.
 - 4) Size and location of concrete and steel bases and curbs.
 - 5) Isolation selected for each support point.
 - 6) Details of mounting brackets for isolator.

- 7) Weight distribution for each isolator.
- 8) Details of seismic snubbers.
- 9) Code number assigned to each isolator.
- c. Design calculations: Provide calculations for selecting vibration isolators and for designing vibration isolation bases.
2. Riser Supports: Include riser diagrams and calculations showing anticipated expansion and contraction at each support point, initial and final loads on building structure, spring deflection changes and seismic loads. Include certification that riser system has been examined for excessive stress and that none will exist.
3. Submittals for Interlocking Snubbers: Include load deflection curves up to 1/2-inch deflection in x, y and z planes.
4. Welding certificates.

1.5 QUALITY ASSURANCE

- A. Quality assurance as required by Section 23 00 00, HVAC Basic Requirements and Division 01, General Requirements.
- B. In addition, meet the following:
 1. Vibration Isolation:
 - a. Except for packaged equipment with integral isolators, single manufacturer selects and furnishes isolation required.
 - b. Deflections indicated on drawings are minimum actual static deflections for specific equipment supported.
 - c. Isolator Stability:
 - 1) Size springs of sufficient diameter to maintain stability of equipment being supported. Spring diameters not less than 0.8 of compressed height at rated load.
 - 2) Springs have minimum additional travel to solid equal to 50 percent of rated deflection.
 - 3) Springs support 200 percent of rated load, fully compressed, without deformation or failure.
 - d. Maximum Allowable Vibration Levels: Peak vibration velocities not exceed 0.08 in/sec. Correct equipment operating at vibration velocities that exceed this criteria.

1.6 WARRANTY

- A. Warranty of materials and workmanship as required by Section 23 00 00, HVAC Basic Requirements and Division 01, General Requirements.

1.7 EXTRA MATERIALS

- A. Furnish extra materials described below that match products installed and that are packaged with protective covering for storage and identified with labels describing contents.
- B. Seismic Snubber Units: Furnish replacement neoprene inserts for snubbers.

PART 2 - PRODUCTS

2.1 MANUFACTURERS

- A. Vibration Isolation:
1. The VMC Group
 2. B-Line Systems, Inc.
 3. Kinetics Noise Control, Inc.
 4. Mason Industries, Inc.
 5. M.W. Saussé - Vibrex
 6. Where Mason numbers are specified, equivalent products by listed manufacturers are acceptable.
 7. Or approved equivalent.
- B. Factory Finishes:
1. Kynar 500 Fluoropolymer Coating
 2. Or approved equivalent.

2.2 VIBRATION ISOLATION

- A. Type 1 - Neoprene Pad: Natural rubber waffle pads, arranged in single or multiple layers, 3/4-inch thick per layer with pattern repeating on 1/2-inch centers; 50 durometer hardness; maximum loading 60 PSI. Minimum 1/4-inch thick steel load distribution plate and 1/16-inch shim plates between layers, factory cut to sizes matching requirements of supported equipment. Molded bridge with neoprene anchor bolt bushing and flat washer face to prevent metal to metal contact. Number of layers required for equipment scheduled. Mason Type: Super WMH.
- B. Type 2 - Neoprene Mount: Double-deflection type, with ductile-iron housing containing two separate and opposing, oil-resistant natural rubber or bridge bearing neoprene elements, factory-drilled, encapsulated top plate for bolting to equipment and with baseplate for bolting to structure. Neoprene elements to prevent metal to metal contact during normal operation. Minimum static deflection of 0.20-inches. Mason Type: BR.
- C. Type 3 - Spring: Freestanding, laterally stable, open-spring isolators.
1. Outside Spring Diameter: Not less than 80 percent of compressed height of spring at rated load.
 2. Minimum Additional Travel: 50 percent of required deflection at rated load.
 3. Lateral Stiffness: More than 80 percent of rated vertical stiffness.
 4. Overload Capacity: Support 200 percent of rated load, fully compressed, without deformation or failure.
 5. Baseplates: Factory drilled for bolting to structure and bonded to 1/4-inch- thick, natural rubber or bridge bearing neoprene isolator pad attached to baseplate underside. Baseplates limit floor load to 100 PSIG (690 kPa).
 6. Top Plate and Adjustment Bolt: Threaded top plate with adjustment bolt and cap screw to fasten and level equipment.
 7. Brackets: Manufacturer's standard bracket, utilize height saving brackets to accommodate height restrictions.
 8. Mason Type: SLFH or SLF.

- D. Type 4a - Restrained Spring Isolators: Freestanding, steel, open-spring isolators with seismic restraint.
1. Housing: Steel with resilient vertical-limit stops (out of contact during normal operation) to prevent spring extension due to wind loads or if weight is removed; factory-drilled baseplate bonded to 1/4-inch thick, natural rubber or bridge bearing neoprene isolator pad attached to baseplate underside; and adjustable equipment mounting and leveling bolt that acts as blocking during installation. Restraining bolts have large rubber grommets to provide cushioning in vertical and horizontal directions. A minimum clearance of 3/8-inch maintained around restraining bolts so as not to interfere with spring action.
 2. Outside Spring Diameter: Not less than 80 percent of compressed height of spring at rated load.
 3. Minimum Additional Travel: 50 percent of required deflection at rated load.
 4. Lateral Stiffness: More than 80 percent of rated vertical stiffness.
 5. Overload Capacity: Support 200 percent of rated load, fully compressed, without deformation or failure.
 6. Brackets: Manufacturer's standard bracket, utilize height saving brackets to accommodate height restrictions.
 7. Mason Type: SLR.
- E. Type 4b - Housed Spring Mounts: Housed spring isolator with integral seismic snubbers.
1. Housing: Ductile-iron or steel housing to provide all-directional seismic restraint with neoprene acoustical cup, spring inspection ports and rebound adjustment ports.
 2. Base: Factory drilled for bolting to structure.
 3. Snubbers: Vertically adjustable to allow a maximum of 1/4-inch travel before contacting a resilient collar.
 4. Brackets: Manufacturer's standard bracket, utilize height saving brackets to accommodate height restrictions.
 5. Mason Type: SSLFH.
- F. Type 5a - Restrained Elastomeric Hangers: Double-deflection type, with molded, oil-resistant natural rubber or bridge bearing neoprene isolator elements bonded to steel housings with threaded connections for hanger rods. Color-code or otherwise identify to indicate capacity range. Seismic rebound steel and bonded LDS rubber washer to limit upward seismic movement. Mason Type: RWHD.
- G. Type 5b- Spring Hangers: Combination coil-spring and elastomeric-insert hanger with spring and insert in compression.
1. Frame: Steel, fabricated for connection to threaded hanger rods and to allow for a maximum of 15 degrees of angular hanger-rod misalignment from vertical without binding or reducing isolation efficiency.
 2. Outside Spring Diameter: Not less than 80 percent of compressed height of spring at rated load.
 3. Minimum Additional Travel: 50 percent of required deflection at rated load.
 4. Lateral Stiffness: More than 80 percent of rated vertical stiffness.
 5. Overload Capacity: Support 200 percent of rated load, fully compressed, without deformation or failure.
 6. Elastomeric Element: Molded, oil-resistant rubber or neoprene. Steel-washer-reinforced cup to support spring and bushing projecting through bottom of frame.
 7. Mason Type: 30N.

- H. Type 5c - Spring Hangers with Vertical-Limit Stop: Combination coil-spring and elastomeric-insert hanger with spring and insert in compression and with a vertical-limit stop.
1. Frame: Steel, fabricated for connection to threaded hanger rods and to allow for a maximum of 15 degrees of angular hanger-rod misalignment from vertical without binding or reducing isolation efficiency.
 2. Outside Spring Diameter: Not less than 80 percent of compressed height of spring at rated load.
 3. Minimum Additional Travel: 50 percent of required deflection at rated load.
 4. Lateral Stiffness: More than 80 percent of rated vertical stiffness.
 5. Overload Capacity: Support 200 percent of rated load, fully compressed, without deformation or failure.
 6. Elastomeric Element: Molded, oil-resistant rubber or neoprene.
 7. Adjustable Vertical Stop: Steel washer with neoprene washer "up-stop" on lower threaded rod.
 8. Mason Type: RW30.
- I. Type 6 - Horizontal Thrust Restraints: Combination coil spring and elastomeric insert with spring and insert in compression and with a load stop. Include rod and angle-iron brackets for attaching to equipment.
1. Frame: Steel, fabricated for connection to threaded rods and to allow for a maximum of 30 degrees of angular rod misalignment without binding or reducing isolation efficiency.
 2. Outside Spring Diameter: Not less than 80 percent of compressed height of spring at rated load.
 3. Minimum Additional Travel: 50 percent of required deflection at rated load.
 4. Lateral Stiffness: More than 80 percent of rated vertical stiffness.
 5. Overload Capacity: Support 200 percent of rated load, fully compressed, without deformation or failure.
 6. Elastomeric Element: Molded, oil-resistant rubber or neoprene.
 7. Coil Spring: Factory set and field adjustable for a maximum of 1/4-inch movement at start and stop.
 8. Mason Type: WBI or WBD.
- J. Type 7 - Pipe Riser Resilient Support: All-directional, acoustical pipe anchor consisting of 2 steel tubes separated by a minimum of 1/2-inch thick, 60-durometer neoprene. Include steel and neoprene vertical-limit stops arranged to prevent vertical travel in both directions. Design support for a maximum load on isolation material of 500 PSIG (3.45 MPa) and for equal resistance in all directions. Mason Type: ADA.
- K. Type 8 - Resilient Pipe Vertical Sliding Guide: Telescopic arrangement of 2 steel tubes separated by a minimum of 1/2-inch thick, 60-durometer neoprene. Factory set guide height with a shear pin to allow vertical motion due to pipe expansion and contraction. Shear pin be removable and reinsertable to allow for selection of pipe movement. Guides be capable of motion to meet location requirements. Mason Type: VSG. Provide pipe expansion hangers to control load shifts as the riser expands or contracts, Mason HES.
- L. Type FC-1, Flexible duct connectors. See Specification Section 23 33 00 Air Duct Accessories.
- M. Type FC-2A, Flexible Pipe Connector, Steel:
1. 321 stainless steel, close pitch, annular corrugated hose.

2. Exterior Sleeve: 304 stainless steel, braided.
 3. Pressure Rating: 125 PSI at 70 degrees F for 12-inch and smaller pipe.
 4. Joint: ANSI Class 150 carbon steel flanges.
 5. Size: Use pipe sized units.
 6. Minimum Allowable Offset: 3/4-inch on each side of installed center line.
 7. Basis of Design: Metraflex Model MLP.
- N. Type FC-2B, Flexible Pipe Connector, Copper:
1. Inner Hose: Bronze, close pitch, annular corrugated hose.
 2. Exterior Sleeve: Braided bronze (for piping over 2-inches, to be 3 pound braided stainless steel).
 3. Minimum Allowable Pressure Rating: 125 PSI at 70 degrees F.
 4. Joint: Sweat ends.
 5. Size: Use pipe sized units.
 6. Minimum Allowable Offset: 3/8-inch on each side of installed center line.
 7. Basis of Design: Metraflex Model BBS.
- O. Type FC-2C, Flexible Pipe Connector, Gas:
1. Inner Hose: 304 stainless steel.
 2. Exterior Sleeve: Braided, 304 stainless steel.
 3. Minimum Allowable Pressure Rating: 150 PSI at 70 degrees F up to 4-inch pipe.
 4. Joint: Threaded carbon steel.
 5. Minimum Allowable Offset: 3/4-inch on each side of installed center line.
 6. Basis of Design: Metraflex GASCT.
- P. Type FC-3, Flexible Compensator, Double Sphere:
1. Body: Molded twin spherical type. Neoprene with internal cord or wire.
 2. Minimum Pressure Rating, Sizes 2-inch to 12-inch: 225 PSI at 170 degrees F.
 3. Minimum Pressure Rating, Sizes 14-inch to 20-inch: 125 PSI at 170 degrees F.
 4. Minimum Allowable Compression: 1-1/2 inches.
 5. Minimum Allowable Elongation: 1-1/8 inches.
 6. Minimum Allowable Offset: 1-1/8 inches.
 7. Minimum Allowable Angular Movement: 20 degrees.
 8. Joint: Steel flanges.
 9. Accessories: Galvanized aircraft-type cable or control rods to prevent over extension.
 10. Basis of Design: Metraflex Doublesphere.

2.3 FACTORY FINISHES

- A. Provide manufacturer's standard prime-coat finish ready for field painting. Units mounted outdoors exposed to weather: Epoxy powder coated, with 1000 hour salt spray rating per ASTM B-117. For high levels of corrosion protection utilize:
1. Conform to AAMA 605.2.
 2. Apply coating following cleaning and pretreatment.
 3. Cleaning: AA-C12C42R1X.
 4. Dry system before final finish application.
 5. Total Dry Film Thickness: Approximately 1.2 mils, when baked at 450 degrees F for 10 minutes.

- B. Finish:
1. Manufacturer's standard paint applied to factory-assembled and factory-tested equipment before shipping.
 2. Powder coating on springs and housings.
 3. Hardware be electrogalvanized. Hot-dip galvanize metal components for exterior use.
 4. Baked enamel for metal components on isolators for interior use.
 5. Color-code or otherwise mark vibration isolation and seismic-control devices to indicate capacity range.

PART 3 - EXECUTION

3.1 GENERAL INSTALLATION REQUIREMENTS

- A. Set floor-mounted equipment with steel base rails on minimum 4-inch-high concrete housekeeping pads. Extend pad minimum 6-inches beyond footprint of equipment in each direction, but not less than twice the embedment depth of concrete anchors.
- B. Provide mounts for equipment installed outdoors for wind loads of 30 lbs. psf applied to any exposed surface of isolated equipment.
- C. Do not install equipment or pipe which makes rigid contact with building slabs, beams, studs, walls, etc.
- D. Anchor baseplate to floor or structure. Provide rubber grommets and washers to isolate bolt from base plate. Under no circumstances is isolation efficiency to be destroyed when bolting isolators to floor.
- E. Building Penetrations: Isolate water piping and ductwork penetrating wall, ceilings, floors or shafts from structure by piping isolator or by 3/8-inch thick foamed rubber insulation. Install units flush with finished structure face, using one for each side as required. Cut units to length if longer than structure thickness. Caulk around pipe or duct at equipment room wall.
- F. Provide roof curbs, equipment supports and roof penetrations. Work to maintain roof warranty. Coordinate location, size, structural connections/requirements and flashing prior to installation.
- G. Install Type 6 horizontal thrust restraints at centerline of thrust, symmetrical on either side of equipment.
- H. Vibration isolators must not cause change of position of equipment or piping which would stress piping connections or misalignment shafts or bearings. Isolated equipment is to be level and in proper alignment with connecting ducts and pipes.
- I. Pipe Hangers in Equipment Rooms: Support water and gas piping connected to rotating equipment within equipment rooms on spring and neoprene hangers. The first three hangers from a piece of vibrating equipment are to have a minimum of 1/2 static deflection of equipment isolators. Other isolators should have a minimum of 1/4 static deflection of equipment isolators.
- J. Examination:

1. Examine areas and equipment to receive vibration isolation and seismic-control devices for compliance with requirements, installation tolerances and other conditions affecting performance.
 2. Examine roughing-in of reinforcement and cast-in-place anchors to verify actual locations before installation.
 3. Proceed with installation only after unsatisfactory conditions have been corrected.
- K. Testing: Perform following field quality-control testing:
1. Isolator deflection.
 2. Snubber minimum clearances.
- L. Adjusting:
1. Adjust snubbers according to manufacturer's written recommendations.
 2. Torque anchor bolts according to equipment manufacturer's written recommendations to resist seismic forces.
- M. Cleaning: After completing equipment installation, inspect vibration isolation and control devices. Remove paint splatters and other spots, dirt and debris.
- N. Demonstration: Engage factory-authorized service representative to train Owner's maintenance personnel to adjust, operate and maintain air-mounting systems. Reference Division 01, General Requirements.

3.2 VIBRATION ISOLATION

- A. Reference 3.01, General Installation Requirements.
- B. Install per manufacturer's instructions and recommendations.
- C. Vibration isolators must be installed in strict accordance with manufacturer's written instructions and certified submittal data.
- D. Install isolation as indicated on drawings by type and location and where indicated below.
- E. Equipment Vibration Isolation Schedule:

Equipment	Size	Vibration Isolator Type	Minimum Deflection (in)
Chillers/Heat Pumps: Reciprocating, Water or Air-Cooled	All	Type 4A or 4B, FC-3	2.5
Chillers/Heat Pumps: Centrifugal, Screw or Scroll, Water or Air-Cooled	All	Type 4A or 4B, FC-3	1.5
Cooling Towers	All	B-1, Type 4A, FC-3	3.5
Boilers	All	Type 1 or 2, FC-2	0.2
Base-Mounted Pumps	0 to 5 HP	B-1, Type 1, FC-3	0.2
Base-Mounted Pumps	7.5+ HP	B-2, Type 1, FC-3	1.5

Inline Pumps	All	Type 4A, 4B, 5B, or 5C, FC-2	1.5
Fan-coils, Unit Heaters, Fan-Powered Terminal Units	All	Type 5B, or 5C, FC-1,2	0.75
Condensing Units	0 to 4.5 tons	Type 1 or 2	0.2
Condensing Units	5+ tons	Type 4A	2.5
Rooftop Air Handlers, AC, Heat Pump Units	0 to 19.5 tons	RC-1, FC-1,2	0.75
Rooftop Air Handlers, AC, Heat Pump Units	20+ tons	RC-2, FC-1,2	1.5
Utility Set Centrifugal Fans	All	4A	1.5
Axial, Cabinet, Centrifugal Inline Fans	0 to 23.5-inch diameter	Type 3, 4A, 4B, 5B, or 5C, FC-1	0.75
Axial, Cabinet, Centrifugal Inline Fans	24-inch+ diameter	Type 3, 4A, 4B, 5B, or 5C, FC-1	1.5
Propeller Fans	All	Type 2 or 5A, FC-1	0.25

F. Isolation Mounts:

1. Install minimum of four seismic snubbers on isolated equipment. Locate snubbers as close as possible to vibration isolators and bolt to equipment base and supporting structure.
2. Install resilient bolt isolation washers on equipment anchor bolts.
3. Provide flexible piping connection and flexible ductwork connection to equipment with isolation mounts or bases.

G. Isolating Hangers:

1. Support piping and ductwork connected to isolated equipment within equipment rooms on isolating hangers as scheduled on drawings. Unless otherwise noted, first three hangers from isolated equipment to have a minimum of 1/2 static deflection of equipment isolators. Other isolating hangers to have a minimum of 1/4 static deflection of equipment isolators.
2. Position isolating hanger elements as high as possible in hanger rod assembly, but not in contact with building structure. Install hangers so that hanger housing may rotate full 360 degrees about rod axis without contacting any object.
3. Unless otherwise noted, air supply units with internally isolated fans do not require isolating hangers for connecting pipes and ductwork.
4. Where parallel running pipes are hung together on an isolated trapeze, provide isolator deflections for largest determined by provisions for pipe isolation. Do not mix isolated and non-isolated pipes in same trapeze.
5. Install limit stops so they are out of contact during normal operation.

H. Adjusting:

1. Adjust isolators after piping systems have been filled and equipment is at operating weight.

2. Adjust limit stops on restrained spring isolators to mount equipment at normal operating height. After equipment installation is complete, adjust limit stops so they are out of contact during normal operation.
3. Attach thrust limits at centerline of thrust and adjust to a maximum of 1/4-inch movement during start and stop.

3.3 FACTORY FINISHES

- A. Reference 3.01, General Installation Requirements.
- B. Install per manufacturer's instructions and recommendations.
- C. Finishes to be factory-applied. No field patching or holidays allowed.

END OF SECTION

SECTION 23 0553 - IDENTIFICATION FOR HVAC PIPING, DUCTWORK AND EQUIPMENT

PART 1 - GENERAL

1.1 SUMMARY

- A. Work Included:
 - 1. Plastic Nameplates
 - 2. Tags
 - 3. Plastic Pipe Markers
 - 4. Ceiling Tags

1.2 RELATED SECTIONS

- A. Contents of Division 23, HVAC and Division 01, General Requirements apply to this Section.

1.3 REFERENCES AND STANDARDS

- A. References and Standards as required by Section 23 00 00, HVAC Basic Requirements and Division 01, General Requirements.

1.4 SUBMITTALS

- A. Submittals as required by Section 23 00 00, HVAC Basic Requirements and Division 01, General Requirements.
- B. In addition, provide:
 - 1. Schedules:
 - a. Submit valve schedule for each piping system, in tabular format using Microsoft Word or Excel software. Tabulate valve number, piping system, system abbreviation (as shown on tag), location of valve (room or space), and variations for identification (if any). Mark valves which are intended for emergency shutoff and similar special uses by special "flags" in margin of schedule. In addition to mounted copies, furnish extra copies for maintenance manuals.

1.5 QUALITY ASSURANCE

- A. Quality assurance as required by Section 23 00 00, HVAC Basic Requirements and Division 01, General Requirements.
- B. In addition, meet the following:
 - 1. Manufacturer's Qualifications: Firms regularly engaged in manufacture of identification devices of types and sizes required.
 - 2. Codes and Standards: Comply with ANSI A13.1 for lettering size, length of color field, colors, and viewing angles of identification devices unless otherwise indicated.

1.6 WARRANTY

- A. Warranty of materials and workmanship as required by Section 23 00 00, HVAC Basic Requirements and Division 01, General Requirements.

PART 2 - PRODUCTS

2.1 MANUFACTURERS

- A. General: Manufacturer's standard products of categories and types required for each application as referenced in other Division 23, HVAC Sections. Where more than a single type is specified for application, provide single selection for each product category.
- B. Plastic Nameplates:
1. Brady Corporation
 2. Brimar
 3. Champion America
 4. Craftmark
 5. Seton
 6. Or approved equivalent.
- C. Tags:
1. Brady Corporation
 2. Brimar
 3. Champion America
 4. Craftmark
 5. Seton
 6. Or approved equivalent.
- D. Plastic Pipe Markers:
1. Brady Corporation
 2. Brimar
 3. Champion America
 4. Craftmark
 5. Seton
 6. Or approved equivalent.
- E. Ceiling Tags:
1. Brady Corporation
 2. Brimar
 3. Champion America
 4. Craftmark
 5. Seton
 6. Or approved equivalent.

2.2 PLASTIC NAMEPLATES

- A. Description: Engraving stock melamine plastic laminate in the size and thicknesses indicated, engraved with engraver's standard letter style of the sizes and wording indicated, black with white core (letter color), punched for mechanical fastening except where adhesive mounting is necessary because of substrate. Provide 1/8-inch thick material.
1. Letter Color: White.
 2. Letter Height: 1/2-inch.
 3. Background Color: Black.

4. Fasteners: Self-tapping stainless steel screws, except contact-type permanent adhesive where screws cannot or should not penetrate the substrate.
5. Access Panel Markers: Manufacturer's standard 1/16-inch thick engraved plastic laminate access panel markers, with abbreviations and numbers corresponding to concealed valve or devices/equipment. Include center hole to allow attachment.

2.3 TAGS

- A. Plastic Tags: Laminated three-layer plastic with engraved black letters on light contrasting background color. Tag size minimum 2-inch diameter.
- B. Metal Tags: Polished Brass with stamped letters; tag size minimum 2-inch diameter with smooth edges.
- C. Valve designations to be coordinated with existing valve identifications to ensure no repetitive designations are utilized.
- D. Chart/Schedules: Valve Schedule Frames. For each page of a valve schedule, provide glazed display frame with removable mounting as appropriate for wall construction upon which frame is to be mounted. Provide frames of finished hardwood or extruded aluminum, with SSB-grade sheet glass.
- E. Valve Tag Fasteners: Solid brass chain (wire link or beaded type), or solid brass S-hooks.
- F. Warning Tags: Preprinted or partially preprinted, accident-prevention tags; of plasticized card stock with matte finish suitable for writing.
 1. Size: Approximately 4 by 7-inches.
 2. Fasteners: Brass grommet and wire.
 3. Nomenclature: Large-size primary caption such as DANGER, CAUTION, or DO NOT OPERATE.
 4. Color: Yellow background with black lettering.

2.4 PLASTIC PIPE MARKERS

- A. Color: Conform to ASME A13.1 and ANSI Z535.1.
- B. Plastic Pipe Markers (for external diameters of 6-inches and larger including insulation): Factory fabricated, flexible, semi-rigid plastic, preformed to fit around pipe or pipe covering; minimum information indicating flow direction arrow and identification of fluid being conveyed.
- C. Plastic Tape Pipe Markers (for external diameters less than 6-inches including insulation): Flexible, vinyl film tape with pressure sensitive adhesive backing and printed markings. Minimum information indicating flow direction arrow and identification of fluid being conveyed.
- D. Lettering:
 1. 3/4-inch to 1-1/4-inch Outside Diameter of Insulation or Pipe: 8-inch long color field, 1/2-inch high letters.
 2. 1-1/2-inch to 2-inch Outside Diameter of Insulation or Pipe: 8-inch long color field, 3/4-inch high letters.

3. 2-1/2-inch to 6-inch Outside Diameter of Insulation or Pipe: 12-inch long color field, 1-1/4-inch high letters.
4. 8-inch to 10-inch Outside Diameter of Insulation or Pipe: 24-inch long color field, 2-1/2-inch high letters.
5. Over 10-inch Outside Diameter of Insulation or Pipe: 32-inch long color field, 3-1/2-inch high letters.

2.5 CEILING TAGS

- A. Description: Steel with 3/4-inch diameter color coded head.
- B. Color code as follows:
 1. Yellow - HVAC equipment.
 2. Red - Fire dampers/smoke dampers.
 3. Blue - Heating/cooling valves.
 4. Ceiling tile labels, machine generated, adhesive backed tape labels with black letters, clear tape.

PART 3 - EXECUTION

3.1 GENERAL - INSTALLATION

- A. Identify air handling units, pumps, heat transfer equipment, tanks, and water treatment devices with plastic nameplates riveted to equipment body.
- B. Identify piping, concealed or exposed, with plastic pipe markers.
- C. Coordinate names, abbreviations and other designations used in mechanical identification work with corresponding designations shown, specified or scheduled. Provide numbers, lettering and wording as indicated or, if not otherwise indicated, as recommended by manufacturers or as required for proper identification and operation/maintenance of mechanical systems and equipment.
- D. Multiple Systems: Where multiple systems of same generic name are shown and specified, provide identification which indicates individual system number as well as service (as examples: Chiller No. 3, Air Handling Unit No. 42, Standpipe F12, and the like).
- E. Degrease and clean surfaces to receive adhesive for identification materials.
- F. Coordination: Where identification is to be applied to surfaces which require insulation, painting or other covering or finish, including valve tags in finished mechanical spaces, install identification after completion of covering and painting. Install identification prior to installation of acoustical ceilings and similar removable concealment.
- G. Coordinate with the facility maintenance personnel to ensure consistency with the existing tagging system.
- H. Install all products in accordance with manufacturer's instructions.
- I. Manual Balancing Dampers: Provide 12-inch long orange marker ribbon to end of balancing damper handle.

3.2 PLASTIC NAMEPLATES

- A. Install plastic nameplates with corrosive-resistant mechanical fasteners.
- B. Identify control panels and major control components outside panels with plastic nameplates riveted to equipment body.
- C. Identify thermostats with nameplates.

3.3 TAGS

- A. Use metal tags on piping 3/4-inch diameter and smaller.
- B. Tag balancing valves and major dampers with balanced GPM or CFM indicated after balancing is completed and accepted.
- C. Install tags with corrosion resistant chain.
- D. Small devices, such as in-line pumps, may be identified with tags.
- E. Identify valves in main and branch piping with metal tags. Indicate valve function and the normally open or closed positions on the valve tag.
- F. Identify air terminal units and radiator valves with numbered plastic tags.
- G. Tag automatic controls, instruments, and relays. Key to control schematic.
- H. Install valve schedule at each mechanical room.

3.4 PLASTIC PIPE MARKERS

- A. Install plastic pipe markers complete around pipe in accordance with manufacturer's instructions.
- B. Identify service, flow direction, and pressure. Install in clear view and align with axis of piping. Locate identification not to exceed 20-feet (reduced to 10-feet in congested areas and mechanical equipment rooms) on straight runs including risers and drops, adjacent to each valve and Tee, at each side of penetration of structure or enclosure, and at each obstruction. Locate near branches, valves, control devices, equipment connections, access doors, floor/wall penetrations.

3.5 CEILING TAGS

- A. Provide ceiling tags to locate valves, dampers, and equipment above accessible ceilings. Locate in corner of ceiling tee grid closest to equipment.

END OF SECTION

SECTION 23 0593 - TESTING, ADJUSTING, AND BALANCING FOR HVAC

PART 1 - GENERAL

1.1 SUMMARY

A. Work Included:

1. General Requirements and Procedures
2. Fundamental Air Systems Balancing Procedures
3. Temperature Control Verification
4. Constant Volume Air Systems Balancing Procedures
5. Fundamental Procedures for Hydronic Systems
6. Pump Balancing Procedures
7. Pre-Balance Reporting
8. Final Reports:
 - a. Report Requirements
 - b. General Report Data
 - c. System Diagrams
 - d. Air Handling Units
 - e. Hydronic Coils
 - f. Fans
 - g. Duct Traverses
 - h. Diffusers/Registers/Grilles
 - i. Pumps
 - j. Instrument Calibration
9. Additional Tests

1.2 RELATED SECTIONS

- A. Contents of Division 23, HVAC and Division 01, General Requirements apply to this Section.

1.3 REFERENCES AND STANDARDS

- A. References and Standards as required by Section 23 00 00, HVAC Basic Requirements and Division 01, General Requirements.

1.4 SUBMITTALS

- A. Submittals as required by Section 23 00 00, HVAC Basic Requirements and Division 01, General Requirements.
- B. In addition, provide:
 1. Quality-Assurance Submittals: Submit two copies of evidence that the Testing, Adjusting, and Balancing (TAB) Agent and this Project's TAB team members meet the qualifications specified in the "Quality Assurance" Article below.
 2. Pre-Construction Phase Report:
 - a. Provide a pre-construction phase TAB Plan at least two weeks prior to the commencement of TAB work. This report is to include:
 - 1) A complete set of report forms intended for use on the project, with data filled in except for the field readings. Forms to be Project-specific.

- 2) Marked up shop drawings identifying all HVAC equipment to be balanced, and associated outlets and terminal devices.
 - 3) Identification of the type, manufacturer, and model of the actual instruments to be used, and clear indication of which instrument will be used to take each type of reading. Calibration certifications are to be included.
 - 4) A narrative of any project specific and/or non-standard TAB procedures to be used, and the equipment or systems they apply to.
3. Contract Documents Examination Report: Within 45 days from the Contractor's Notice to Proceed, submit two copies of the Contract Documents review report as specified in Part 3 of this Section.
 4. Strategies and Procedures Plan: Submit two copies of the TAB strategies and step-by-step procedures as specified in Part 3 below. Include a complete set of report forms intended for use on this Project.
 5. Specify reports required because of editing procedures in Part 3 of this Section.
 6. Certified TAB Reports: Submit two copies of reports prepared, as specified in this Section, on approved forms certified by the TAB Agent.
 7. Sample Report Forms: Submit two sets of sample TAB report forms.
 8. Test Instrument Calibration: Submit proof of calibration within the last 6 months.
 9. Final Report.
 10. Provide additional submittals to commissioning authority as dictated in commissioning specifications.

1.5 QUALITY ASSURANCE

- A. Quality Assurance as required by Section 23 00 00, HVAC Basic Requirements and Division 01, General Requirements.
- B. In addition, meet the following:
 1. Balance Firm Qualifications:
 - a. General:
 - 1) Procure services of independent TAB agency to balance, adjust and test water circulating and air moving equipment and air distribution or exhaust systems. Minimum experience: 5 years.
 - 2) Provide proof of testing agency having successfully completed at least five projects of similar size and scope.
 - b. Testing and Balancing firm is certified by NEBB or AABC and has a NEBB Certified Professional (CP) or a AABC Test and Balancer Engineer (TBE) on staff.
 - c. Industry Standards: Testing and Balancing will conform to NEBB or AABC, and American National Standards Institute (ANSI) as follows:
 - 1) NEBB: Comply with Procedural Standards for Testing, Adjusting, and Balancing of Environmental Systems.
 - 2) AABC: Comply with National Standards for Total System Balance.
 - 3) ANSI:
 - (a) S1.4 Specifications for sound level meters.
 - (b) S1.11 Specifications for Octave-Band and Fractional-Octave-Band analog and digital filters.
 - (c) ANSI S1.13 Methods for the Measurement of Sound Pressure Levels.
 - d. Test Observation: If requested, conduct tests in the presence of the Commissioning Authority, AHJ, Architect or the Architect's representative.
 2. Noise Criteria:

- a. Noise levels in all 8 octave bands due to equipment and duct systems are not to exceed the following NC levels:

TYPE OF ROOM	NC LEVEL
Bathrooms and Toilet Rooms	35-40
Conference Room	30-35
Corridors (Public)	35-40
Lobbies, Waiting Areas	35-40
Offices, Large Open (3 or more occupants)	35-40
Offices, Small Private (2 or fewer occupants)	30-35
Kitchens	40-45
Classrooms (Small, Medium, Large)	30-35
Cafeteria/Dining	35-40
All Others	35-40

- b. An allowance, not to exceed 5db, may be added to the measured value to compensate for the variation of the room attenuating effect between room test condition prior to occupancy and design condition after occupancy which may include the addition of sound absorbing material, such as furniture. This allowance may not be taken after occupancy. The room attenuating effect is defined as the difference between sound power level emitted to room and sound pressure level in room.
 - c. In absence of specified measurement requirements, measure equipment noise levels three feet from equipment and at an elevation of maximum noise generation.
3. Code Compliance: Perform tests in the presence of the Authority Having Jurisdiction (AHJ) where required by the Authority Having Jurisdiction (AHJ).
 4. Owner Witness: Perform tests in the presence of the Commissioning Authority, Architect, Architect's Representative, or Owner's representative.
 5. Engineer Witness: The engineer or engineer's representative reserves the right to observe tests or selected tests to assure compliance with the specifications.
 6. Simultaneous Testing: Test observations by the AHJ, the Owner's Authorized Representative and the engineer's representative need not occur simultaneously.
 7. Do not perform TAB work until heating, ventilating, and air conditioning equipment has been completely installed and is operating continuously as required.
 8. Conduct air testing and balancing with clean filters in place. Clean strainers prior to performing hydronic testing and balancing.
 9. TAB Conference: Meet with the Commissioning Authority, Owner's and the Architect's representatives on approval of the TAB strategies and procedures plan to develop a mutual understanding of the details. Ensure the participation of TAB team members, equipment manufacturers' authorized service representatives, HVAC controls Installer, and other support personnel. Provide 7 days advance notice of scheduled meeting time and location.
 - a. Agenda Items: Include at least the following:
 - 1) Submittal distribution requirements.
 - 2) Contract Documents examination report.
 - 3) TAB plan.
 - 4) Work schedule and Project site access requirements.

- 5) Coordination and cooperation of trades and subcontractors.
- 6) Coordination of documentation and communication flow.
10. Certification of TAB Reports: This certification includes the following:
 - a. Review field data reports to validate accuracy of data and to prepare certified TAB reports.
 - b. Certify that the TAB team complied with the approved TAB plan and the procedures specified and referenced in this Specification.
11. TAB Reports: Use standard forms from AABC or NEBB.
12. Instrumentation Type, Quantity, and Accuracy: As described in AABC or NEBB.
13. Instrumentation Calibration: Calibrate instruments at least every 6 months or more frequently if required by the instrument manufacturer.

1.6 WARRANTY

- A. Warranty of materials and workmanship as required by Section 23 00 00, HVAC Basic Requirements and Division 01, General Requirements.
- B. In addition, provide:
 1. TAB Agency provides warranty for a period of 90 days following submission of completed report, during which time, Owner may request a recheck of up to 10 percent of total number of terminals, or resetting of any outlet, coil, or device listed in the final TAB report.
 2. Guarantee: Meet the requirements of the following programs:
 - a. Provide a guarantee on AABC or NEBB forms stating that the agency will assist in completing the requirements of the Contract Documents if the TAB Agent fails to comply with the Contract Documents. Guarantee includes the following provisions:
 - 1) The certified Agent has tested, adjusted, and balanced systems according to the Contract Documents.
 - 2) Systems are balanced to optimum performance capabilities within design and installation limits.

1.7 DEFINITIONS

- A. Adjust: To regulate fluid flow rate and air patterns at the terminal equipment, such as to reduce fan speed or adjust a damper.
- B. Balance: To proportion flows within the distribution system, including submains, branches, and terminals, according to design quantities.
- C. Draft: A current of air, when referring to localized effect caused by one or more factors of high air velocity, low ambient temperature, or direction of airflow, whereby more heat is withdrawn from a persons skin than is normally dissipated.
- D. Procedure: An approach to and execution of a sequence of work operations to yield repeatable results.
- E. Report Forms: Test data sheets for recording test data in logical order.

- F. Static Head: The pressure due to the weight of the fluid above the point of measurement. In a closed system, static head is equal on both sides of the pump.
- G. Suction Head: The height of fluid surface above the centerline of the pump on the suction side.
- H. System Effect: A phenomenon that can create undesired or unpredicted conditions that cause reduced capacities in all or part of a system.
- I. System Effect Factors: Allowances used to calculate a reduction of the performance ratings of a fan when installed under conditions different from those presented when the fan was performance tested.
- J. TAB: Testing, Adjusting, and Balancing.
- K. Terminal: A point where the controlled medium, such as fluid or energy, enters or leaves the distribution system.
- L. Test: A procedure to determine quantitative performance of a system or equipment.
- M. Testing, Adjusting, and Balancing (TAB) Agent: The entity responsible for performing and reporting the TAB procedures.
- N. AABC: Associated Air Balance Council.
- O. NEBB: National Environmental Balancing Bureau.
- P. AMCA: Air Movement and Control Association.
- Q. CTI: Cooling Tower Institute.
- R. SMACNA: Sheet Metal and Air Conditioning Contractors' National Association.

1.8 COORDINATION

- A. Coordinate the efforts of factory-authorized service representatives for systems and equipment, HVAC controls installers, and other mechanics to operate HVAC systems and equipment to support and assist TAB activities.
- B. Notice: Provide 7 days advance notice for each test. Include scheduled test dates and times.
- C. Witness leakage and pressure tests carried out by Section 233100.
- D. Perform TAB after leakage and pressure tests on air and water distribution systems have been satisfactorily completed.

PART 2 - PRODUCTS - NOT USED

PART 3 - EXECUTION

3.1 GENERAL REQUIREMENTS AND PROCEDURES

A. Project Conditions:

1. Full Owner Occupancy: The Owner will occupy the site and existing building during the entire TAB period. Cooperate with the Owner during TAB operations to minimize conflicts with the Owner's operations.
2. Partial Owner Occupancy: The Owner may occupy completed areas of the building before Substantial Completion. Cooperate with the Owner during TAB operations to minimize conflicts with the Owner's operations.
3. Non-Owner Occupancy: Complete balancing of building systems prior to Substantial Completion and owner occupancy.

B. General Requirements:

1. Where HVAC systems and/or components interface with life safety systems, including fire and smoke detection, alarm, and controls, coordinate scheduling and testing and inspection procedures with authorities having jurisdiction.
2. Perform TAB work with doors, closed windows, and ceilings installed etc., to obtain simulated or project operating conditions. Do not proceed until systems scheduled for TAB are clean and free from debris, dirt and discarded building materials.
3. Where Owner occupies building during the testing period, cooperate with Owner to minimize conflicts with Owner's operations.

C. Examination:

1. Examine Contract Documents to become familiar with project requirements and existing building record documents (if available) to discover conditions in systems' designs that may preclude proper TAB of systems and equipment.
 - a. Contract Documents are defined in the General and Supplementary Conditions of the Contract.
 - b. Verify that balancing devices, such as test ports, gauge cocks, thermometer wells, flow-control devices, balancing valves and fittings, and manual volume dampers, are required by the Contract Documents. Verify that quantities and locations of these balancing devices are accessible and appropriate for effective balancing and for efficient system and equipment operation.
2. Examine approved submittal data of HVAC systems and equipment.
3. Examine project record documents described in Division 01, General Requirements.
4. Examine Architect's and Engineer's design data, including Basis of Design, HVAC system descriptions, statements of design assumptions for environmental conditions and systems' output, and statements of philosophies and assumptions about HVAC system and equipment controls.
5. Examine equipment performance data, including fan and pump curves. Relate performance data to project conditions and requirements, including system effects that can create undesired or unpredicted conditions that cause reduced capacities in all or part of a system. Calculate system effect factors to reduce the performance ratings of HVAC equipment when installed under conditions different from those presented when the equipment was performance tested at the factory. To calculate system effects for air

systems, use tables and charts found in AMCA 201, "Fans and Systems," Sections 7 through 10; or in SMACNA's "HVAC Systems--Duct Design," Sections 5 and 6.

Compare this data with the design data and installed conditions.

6. Coordinate requirements in system and equipment with this Section.
7. Examine system and equipment installations to verify that they are complete and that testing, cleaning, adjusting, and commissioning specified in individual Specification Sections have been performed.
8. Examine system and equipment test reports.
9. Examine HVAC system and equipment installations to verify that indicated balancing devices, such as test ports, gauge cocks, thermometer wells, flow-control devices, balancing valves and fittings, and manual volume dampers, are properly installed, and their locations are accessible and appropriate for effective balancing and for efficient system and equipment operation.
10. Examine systems for functional deficiencies that cannot be corrected by adjusting and balancing.
11. Examine equipment for installation and for properly operating safety interlocks and controls.
12. Report deficiencies discovered before and during performance of TAB procedures.

D. Preparation:

1. Prepare a TAB plan that includes strategies and step-by-step procedures.
2. Complete system readiness checks and prepare system readiness reports. Verify the following:
 - a. Permanent electrical power wiring is complete.
 - b. Hydronic systems are filled, clean, and free of air.
 - c. Automatic temperature-control systems are operational.
 - d. Equipment and duct access doors are securely closed.
 - e. Balance, smoke, and fire dampers are open.
 - f. Isolating and balancing valves are open and control valves are operational.
 - g. Ceilings are installed in critical areas where air-pattern adjustments are required and access to balancing devices is provided.
 - h. Windows, doors and other portions of the building envelope can be closed so design conditions for system operations can be met.
3. Hold a pre-balancing meeting at least one week prior to starting TAB work.
 - a. Attendance is required by installers whose work will be tested, adjusted, or balanced.
4. Provide instruments required for TAB operations. Make instruments available to Architect to facilitate spot checks during testing.

E. General TAB Procedures:

1. Perform TAB procedures on each system according to the procedures contained in AABC or NEBB and this Section.
2. Coordinate location of test probes prior to start of TAB procedures and make test probes available for Owner's tests after start of occupancy. Where required, cut insulation, ducts, pipes, and equipment cabinets for installation of test probes to the minimum extent necessary to allow adequate performance of procedures. After testing and balancing, close probe holes and patch insulation with new materials identical to those removed. Restore vapor barrier and finish according to the insulation Specifications for this Project.

3. Mark equipment settings with paint or other suitable, permanent identification material, including damper-control positions, valve indicators, fan-speed-control levers, and similar controls and devices, to show final settings.

F. Adjustment Tolerances:

1. Air Handling Systems: Adjust to within plus or minus 5 percent of design for supply systems and plus or minus 5 percent of design for return and exhaust systems.
2. Air Outlets and Inlets: Adjust total to within plus 10 percent and minus 5 percent of design. Adjust outlets and inlets in space to within plus or minus 10 percent of design.
3. Hydronic Systems: Adjust to within plus or minus 10 percent of design at coils and plus or minus 5 percent at system pumps and equipment.
4. Adjust supply, return, and exhaust air quantities to maintain pressurization in spaces indicated on Drawings. Note and document room-to-room pressurization and maintain these relationships. Adjust pressure controlled spaces to within plus or minus 0.01 in WC.

G. Recording and Adjusting:

1. Field Logs: Maintain written logs including:
 - a. Running log of events and issues.
 - b. Discrepancies, deficient or uncompleted work by others.
 - c. Contract interpretation requests.
 - d. Lists of completed tests.
2. Ensure recorded data represents actual measured or observed conditions.
3. Permanently mark settings of valves, dampers, and other adjustment devices allowing settings to be restored. Set and lock memory stops.
4. Mark on drawings locations where traverse and other critical measurements were taken and cross reference location in final report.
5. After adjustment, take measurements to verify balance has not been disrupted or that such disruption has been rectified.
6. Leave systems in proper working order, replacing belt guards, closing access doors, closing doors to electrical switch boxes, and restoring thermostats to specified settings.
7. At final inspection, recheck random selections of data recorded in report. Recheck points or areas as selected and witnessed by Owner's Authorized Representative, or Commissioning Agent.

3.2 FUNDAMENTAL AIR SYSTEMS BALANCING PROCEDURES

- A. Examine air-handling equipment to ensure clean filters have been installed, bearings are greased, belts are aligned and tight, and equipment with functioning controls is ready for operation.
- B. Examine terminal units, such as variable-air-volume boxes and mixing boxes, to verify that they are accessible and their controls are connected and functioning.
- C. Examine heat-transfer coils for correct piping connections and for clean and straight fins.
- D. Prepare test reports for both fans and inlets and outlets. Obtain manufacturer's outlet factors and recommended testing procedures. Cross check the summation of required outlet volumes with required fan volumes.

- E. Prepare schematic diagrams of systems' "as-built" duct layouts.
- F. Determine the best locations in main and branch ducts for accurate duct airflow measurements.
- G. Check the airflow patterns from the outside-air louvers and dampers and the return- and exhaust-air dampers, through the supply-fan discharge and mixing dampers.
- H. Locate start-stop and disconnect switches, electrical interlocks, and motor starters.
- I. Verify that motor starters are equipped with thermal protection, sized for the connected load.
- J. Check dampers for proper position to achieve desired airflow path.
- K. Check for airflow blockages.
- L. Check that condensate drains are installed, trapped and primed and routed to drain.
- M. Check for readily observable leaks in air-handling unit components and ductwork.
- N. Use sheaves and pulleys to adjust the speed of belt drive fans to achieve design flow with motors running at 60 Hertz unless noted otherwise.

3.3 TEMPERATURE CONTROL VERIFICATION

- A. Examine automatic temperature system components to verify the following:
 - 1. Dampers, valves, and other controlled devices operate by the intended controller.
 - 2. Dampers and valves are in the position indicated by the controller.
 - 3. Integrity of valves and dampers for free and full operation and for tightness of fully closed and fully open positions. This includes dampers in multizone units, mixing boxes, and variable-air-volume terminals.
 - 4. Automatic modulating and shutoff valves, including 2-way valves and 3-way mixing and diverting valves, are properly connected.
 - 5. Thermostats and humidistats are located to avoid adverse effects of sunlight, equipment, drafts, and cold walls.
 - 6. Sensors are located to sense only the intended conditions.
 - 7. Sequence of operation for control modes is according to the Contract Documents.
 - 8. Controller set points are set at design values. Observe and record system reactions to changes in conditions. Record default set points if different from design values.
 - 9. Interlocked systems are operating.
 - 10. Changeover from heating to cooling mode occurs according to design values.
- B. Verify that controllers are calibrated and commissioned.
- C. Check transmitter and controller locations and note conditions that would adversely affect control functions.
- D. Record controller settings and note variances between set points and actual measurements.
- E. Verify operation of limiting controllers (i.e., high- and low-temperature controllers).

- F. Verify free travel and proper operation of control devices such as damper and valve operators.
- G. Verify sequence of operation of control devices. Note air pressures and device positions and correlate with airflow and water-flow measurements. Note the speed of response to input changes.
- H. Confirm interaction of electrically operated switch transducers.
- I. Confirm interaction of interlock and lockout systems.
- J. Verify main control supply-air pressure and observe compressor and dryer operations.
- K. Note operation of electric actuators using spring return for proper fail-safe operations.

3.4 CONSTANT VOLUME AIR SYSTEMS BALANCING PROCEDURES

- A. Adjust fans to deliver total design airflows within the maximum allowable rpm listed by the fan manufacturer. Adjust fans to deliver design airflow at the lowest possible speed.
 - 1. Measure fan static pressures to determine actual static pressure as follows:
 - a. Measure outlet static pressure as far downstream from the fan as practicable and upstream from restrictions in ducts such as elbows and transitions.
 - b. Measure static pressure directly at the fan outlet or through the flexible connection.
 - c. Measure inlet static pressure of single-inlet fans in the inlet duct as near the fan as possible, upstream from flexible connection and downstream from duct restrictions.
 - d. Measure inlet static pressure of double-inlet fans through the wall of the plenum that houses the fan.
 - 2. Measure static pressure across each air-handling unit component under final balanced condition.
 - 3. Compare design data with installed conditions to determine variations in design static pressures versus actual static pressures. Recommend corrective action to align design and actual conditions.
 - 4. Make required adjustments to pulley sizes, motor sizes, and electrical connections to accommodate fan-speed changes.
 - 5. Do not make fan-speed adjustments that result in motor loading greater than full load amps. Do not increase fan speed beyond fan class rating. Modulate dampers and measure fan-motor amperage to ensure no overload will occur. Measure amperage in full cooling, full heating, and economizer modes to determine the maximum required brake horsepower.
 - 6. Adjust volume dampers for main duct, submain ducts, and major branch ducts to design airflows within specified tolerances.
 - 7. Calibrate airflow measuring stations.

3.5 FUNDAMENTAL PROCEDURES FOR HYDRONIC SYSTEMS

- A. Examine strainers for clean screens and proper perforations.
- B. Examine 3-way valves for proper installation for their intended function of diverting or mixing fluid flows.

- C. Examine open-piping-system pumps to ensure absence of entrained air in the suction piping.
- D. Prepare test reports with pertinent design data and number in sequence starting at pump to end of system. Check the sum of branch-circuit flows against approved pump flow rate. Correct variations that exceed plus or minus 5 percent.
- E. Prepare schematic diagrams of systems' "as-built" piping layouts.
- F. Prepare hydronic systems for TAB according to the following, in addition to the general preparation procedures specified above:
 - 1. Open manual valves for maximum flow.
 - 2. Check expansion tank liquid level, or air charge if bladder type.
 - 3. Check makeup-water-station pressure gauge for adequate pressure for highest vent.
 - 4. Check flow-control valves for specified sequence of operation and set at design flow.
 - 5. Set differential-pressure control valves at the specified differential pressure.
 - 6. Set system controls so automatic valves are wide open to heat exchangers and coils.
 - 7. Check pump-motor load. If motor is overloaded, throttle main flow-balancing device so motor nameplate rating is not exceeded.
 - 8. Check air vents for a forceful liquid flow exiting from vents when manually operated.
- G. Calibrate waterflow measuring stations.

3.6 PUMP BALANCING PROCEDURES

- A. Determine water flow at pumps. Use the following procedures:
 - 1. Verify impeller size by operating the pump with the discharge valve closed. Read pressure differential across the pump. Convert pressure to head and correct for differences in gauge heights. Note the point on the manufacturer's pump curve at zero flow and confirm that the pump has the intended impeller size.
 - 2. Check system resistance. With valves open, read pressure differential across the pump and mark the pump manufacturer's head-capacity curve. Adjust pump discharge valve until design water flow is achieved. Report flow rates that are not within plus or minus 5 percent of design.
 - 3. Verify pump-motor amperage. Report conditions where actual amperage exceeds motor nameplate amperage.
 - 4. Set calibrated balancing valves, if installed, at calculated presettings.
 - 5. Measure flow at stations and adjust, where necessary, to obtain first balance. System components that have Cv rating or an accurately cataloged flow-pressure-drop relationship may be used as a flow-indicating device.
 - 6. Measure flow at main balancing station and set main balancing device or adjust pump speed to achieve flow that is 5 percent greater than design flow.
 - 7. Adjust balancing stations to within specified tolerances of design flow rate as follows:
 - a. Determine the balancing station with the highest percentage over design flow.
 - b. Adjust each station in turn, beginning with the station with the highest percentage over design flow and proceeding to the station with the lowest percentage over design flow.
 - c. Record settings and mark balancing devices.
 - 8. Measure pump flow rate and make final measurements of pump amperage, voltage, rpm, pump heads, and systems' pressures and temperatures, including outdoor-air temperature.

9. Measure the differential-pressure control valve settings existing at the conclusions of balancing.

3.7 PRE-BALANCE REPORTING

A. Pre-Construction Phase Report:

1. Provide a pre-construction phase TAB Plan at least 2 weeks prior to the commencement of TAB work. This report is to include:
 - a. A complete set of report forms intended for use on the project, with all data filled in except for the field readings. Forms to be project specific.
 - b. Marked up shop drawings identifying all HVAC equipment to be balanced, and associated outlets and terminal devices.
 - c. Identification of the type, manufacturer, and model of actual instruments to be used, and clear indication of which instrument will be used to take each type of reading. Calibration certifications are to be included.
 - d. A narrative of any project specific and/or non-standard TAB procedures to be used, and the equipment or systems they apply to.

- #### B. Initial Construction-Phase Report: Based on examination of the Contract Documents as specified in "Examination" Article above, prepare a report on the adequacy of design for systems' balancing devices. Recommend changes and additions to systems' balancing devices to facilitate proper performance measuring and balancing. Recommend changes and additions to HVAC systems and general construction to allow access for performance measuring and balancing devices.

- #### C. Status Reports: As Work progresses, prepare reports to describe completed procedures, procedures in progress, and scheduled procedures. Include a list of deficiencies and problems found in systems being tested and balanced.

3.8 FINAL REPORTS

A. Report Requirements:

1. General:
 - a. Computer generated in PDF format and tabulated, divided, and bookmarked into sections by tested and balanced systems.
 - b. Include a certification sheet in front of binder signed and sealed by the certified TAB engineer.
 - 1) Include a list of the instruments used for procedures, along with proof of calibration.
 - c. Final Report Contents: In addition to the certified field report data, include the following:
 - 1) Pump curves.
 - 2) Fan Curves
 - 3) Manufacturers Test Data
 - 4) Field test reports prepared by system and equipment installers.
 - 5) Other information relative to equipment performance, but do not include approved Shop Drawings and Product Data.

B. General Report Data:

1. In addition to the form titles and entries, include the following data in the final report, as applicable:
 - a. Title Page
 - b. Name and Address of TAB Agent
 - c. Project Name
 - d. Project Location
 - e. Architect's Name and Address
 - f. Engineer's Name and Address
 - g. Contractor's Name and Address
 - h. Report Date
 - i. Signature of TAB Agent who Certifies the Report
 - j. Summary of Contents, Including the Following:
 - 1) Design versus Final Performance
 - 2) Notable Characteristics of Systems
 - 3) Description of System Operation Sequence if it varies from the Contract Documents
 - k. Nomenclature Sheets for Each Item of Equipment
 - l. Data for Terminal Units, including Manufacturer, Type Size, and Fittings
 - m. Notes to explain why certain final data in the body of reports vary from design values.
 - n. Test Conditions for Fans and Pump Performance Forms, Including the Following:
 - 1) Settings for Outside-, Return-, and Exhaust-air Dampers
 - 2) Conditions of Filters
 - 3) Cooling Coil, Wet- and Dry-bulb Conditions
 - 4) Face and Bypass Damper Settings at Coils
 - 5) Fan Drive Settings, including Settings and Percentage of Maximum Pitch Diameter
 - 6) Inlet Vane Settings for Variable-Air-Volume Systems
 - 7) Settings for Supply-air, Static-pressure Controller
 - 8) Other System Operating Conditions that affect Performance
- C. System Diagrams:
 1. Include schematic layouts of air and hydronic distribution systems. Present with single-line diagrams and include the following:
 - a. Quantities of Outside, Supply, Return, and Exhaust Airflows
 - b. Water and Steam Flow Rates
 - c. Duct, Outlet, and Inlet Sizes
 - d. Pipe and Valve Sizes and Locations
 - e. Terminal Units
 - f. Balancing Stations
- D. Air Handling Units:
 1. For air-handling units, split systems, fan coils, pumps, and evaporator units with coils, include the following:
 - a. Unit Data: Include the following:
 - 1) Unit Identification
 - 2) Location
 - 3) Make and Type
 - 4) Model Number and Unit Size

- 5) Manufacturer's Serial Number
- 6) Unit Arrangement and Class
- 7) Discharge Arrangement
- 8) Sheave Make, Size in inches, and Bore
- 9) Sheave Dimensions, Center-to-center and Amount of Adjustments in Inches
- 10) Number of Belts, Make, and Size
- 11) Number of Filters, Type, and Size
- b. Motor Data: Include the following:
 - 1) Make and Frame Type and Size
 - 2) Horsepower and rpm
 - 3) Volts, Phase, and Hertz
 - 4) Full-load Amperage and Service Factor
 - 5) Sheave Make, Size in Inches, and Bore
 - 6) Sheave Dimensions, Center-to-center and Amount of Adjustments in Inches
- c. Test Data: Include design and actual values for the following:
 - 1) Total Airflow Rate in cfm (L/s)
 - 2) Total System Static Pressure in Inches wg (Pa)
 - 3) Fan rpm
 - 4) Discharge Static Pressure in Inches wg (Pa)
 - 5) Filter Static-pressure Differential in Inches wg (Pa)
 - 6) Preheat Coil Static-pressure Differential in Inches wg (Pa)
 - 7) Cooling Coil Static-pressure Differential in Inches wg (Pa)
 - 8) Heating Coil Static-pressure Differential in Inches wg (Pa)
 - 9) Outside Airflow in cfm (L/s)
 - 10) Return Airflow in cfm (L/s)
 - 11) Outside-air Damper Position
 - 12) Return-air Damper Position
 - 13) Vortex Damper Position

E. Hydronic Coils:

1. For hydronic coils in all equipment with coils, include the following:
 - a. Coil Data: Include the following:
 - 1) System Identification
 - 2) Location and Zone
 - 3) Room or Riser Served
 - 4) Coil Type
 - 5) Number of Rows
 - 6) Fin Spacing in Fins per Inch o.c.
 - 7) Make and Model Number
 - 8) Face Area in SF
 - 9) Tube Size in NPS (DN)
 - 10) Tube and fin Materials
 - 11) Circuiting Arrangement
 - b. Test Data: Include design and actual values for the following:
 - 1) Airflow Rate in cfm
 - 2) Average Face Velocity in fpm
 - 3) Air Pressure Drop in Inches wg
 - 4) Outside-air, Wet- and Dry-bulb Temperatures in Degrees F
 - 5) Return-air, Wet- and Dry-bulb Temperatures in Degrees F

- 6) Entering-air, Wet- and Dry-bulb Temperatures in Degrees F
- 7) Leaving-air, Wet- and Dry-bulb Temperatures in Degrees F
- 8) Water Flow Rate in gpm
- 9) Water Pressure Differential in Feet of Head or PSIG
- 10) Entering-water Temperature in Degrees F
- 11) Leaving-water Temperature in Degrees F

F. Fans:

1. Fan Test Reports: For supply, return, and exhaust fans, include the following:
 - a. Fan Data: Include the following:
 - 1) System Identification
 - 2) Location
 - 3) Make and Type
 - 4) Model Number and Size
 - 5) Manufacturer's Serial Number
 - 6) Arrangement and Class
 - 7) Sheave Make, Size in Inches, and Bore
 - 8) Sheave Dimensions, Center-to-center and Amount of Adjustments in Inches.
 - b. Motor Data: Include the following:
 - 1) Make and Frame Type and Size
 - 2) Horsepower and rpm
 - 3) Volts, Phase, and Hertz
 - 4) Full-load Amperage and Service Factor
 - 5) Sheave Make, Size in Inches, and Bore
 - 6) Sheave Dimensions, Center-to-center and Amount of Adjustments in Inches
 - 7) Number of Belts, Make, and Size
 - c. Test Data: Include design and actual values for the following:
 - 1) Total Airflow Rate in cfm
 - 2) Total System Static Pressure in Inches wg
 - 3) Fan rpm
 - 4) Discharge Static Pressure in Inches wg
 - 5) Suction Static Pressure in Inches wg

G. Duct Traverses:

1. Include a diagram with a grid representing the duct cross-section and record the following:
 - a. Report Data: Include the following:
 - 1) System and Air-handling Unit Number
 - 2) Location and Zone
 - 3) Duct Static Pressure in Inches wg
 - 4) Duct Size in Inches
 - 5) Duct Area in SF
 - 6) Design Airflow Rate in cfm
 - 7) Design Velocity in fpm
 - 8) Actual Airflow Rate in cfm
 - 9) Actual Average Velocity in fpm

H. Diffusers/Registers/Grilles:

1. For diffusers, registers and grilles, include the following:

- a. Unit Data: Include the following:
 - 1) System and Air-handling Unit Identification
 - 2) Location and Zone
 - 3) Test Apparatus Used
 - 4) Area Served
 - 5) Air-terminal-device Make
 - 6) Air-terminal-device Number from System Diagram
 - 7) Air-terminal-device Type and Model Number
 - 8) Air-terminal-device Size
 - 9) Air-terminal-device Effective Area in SF
- b. Test Data: Include design and actual values for the following:
 - 1) Airflow Rate in cfm
 - 2) Air Velocity in fpm
 - 3) Final Airflow Rate in cfm
 - 4) Final Velocity in fpm
 - 5) Space Temperature in Degrees F

I. Pumps:

1. For pumps, include the following data. Calculate impeller size by plotting the shutoff head on pump curves.
 - a. Unit Data: Include the following:
 - 1) Unit Identification
 - 2) Location
 - 3) Service
 - 4) Make and Size
 - 5) Model and Serial Numbers
 - 6) Water Flow Rate in gpm
 - 7) Water Pressure Differential in Feet of Head or PSIG
 - 8) Required Net Positive Suction Head in Feet of Head or PSIG
 - 9) Pump rpm
 - 10) Impeller Diameter in Inches
 - 11) Motor Make and Frame Size
 - 12) Motor Horsepower and rpm
 - 13) Voltage at Each Connection
 - 14) Amperage for Each Phase
 - 15) Full-load Amperage and Service Factor
 - 16) Seal Type
 - b. Test Data: Include design and actual values for the following:
 - 1) Static Head in Feet of Head or PSIG
 - 2) Pump Shutoff Pressure in Feet of Head or PSIG
 - 3) Actual Impeller Size in Inches
 - 4) Full-open Flow Rate in gpm
 - 5) Full-open Pressure in Feet of Head or PSIG
 - 6) Final Discharge Pressure in Feet of Head or PSIG
 - 7) Final Suction Pressure in Feet of Head or PSIG
 - 8) Final Total Pressure in Feet of Head or PSIG
 - 9) Final Water Flow Rate in gpm
 - 10) Voltage at Each Connection
 - 11) Amperage for Each Phase

- J. Instrument Calibration:
 - 1. For instrument calibration, include the following:
 - a. Report Data: Include the following:
 - 1) Instrument Type and Make
 - 2) Serial Number
 - 3) Application.
 - 4) Dates of Use
 - b. Dates of Calibration.

3.9 ADDITIONAL TESTS

- A. Within 90 days of completing TAB, perform additional testing and balancing to verify that balanced conditions are being maintained throughout and to correct unusual conditions.
- B. Seasonal Periods: If initial TAB procedures were not performed during near-peak summer and winter conditions, perform additional inspections, testing, and adjusting during near-peak summer and winter conditions.

END OF SECTION

SECTION 23 0700 - HVAC INSULATION

PART 1 - GENERAL

1.1 SUMMARY

- A. Work Included:
 - 1. Type A, Flexible Glass Wool Blanket
 - 2. Type B, Duct Liner
 - 3. Type 1, Glass Wool Pipe Insulation
 - 4. Type 2, Flexible Elastomeric Pipe Insulation
 - 5. Jacketing
 - 6. Accessories
 - 7. Duct Insulation Accessories
 - 8. Duct Insulation Compounds
 - 9. Outdoor Ducting Cover

1.2 RELATED SECTIONS

- A. Contents of Division 23, HVAC and Division 01, General Requirements apply to this Section.

1.3 REFERENCES AND STANDARDS

- A. References and Standards as required by Section 23 00 00, HVAC Basic Requirements and Division 01, General Requirements.
- B. In addition, meet the following:
 - 1. Piping and duct insulation products to contain less than 0.1 percent by weight PBDE in all insulating materials.

1.4 SUBMITTALS

- A. Submittals as required by Section 23 00 00, HVAC Basic Requirements and Division 01, General Requirements.
- B. In addition, provide:
 - 1. Installer qualifications.
 - 2. Product Data: Identify thermal conductivity, thickness, and jackets (both factory and field applied, if any) for each type of product indicated.
 - 3. Material Test Reports: From a qualified testing agency acceptable to authorities having jurisdiction indicating, interpreting, and certifying test results for compliance of insulation materials, sealers, attachments, cements, and jackets with requirements indicated. Include dates of tests.
 - 4. Installer Certificates: Signed by the Contractor certifying that installers comply with requirements.
 - 5. Submit manufacturer's installation instructions.

1.5 QUALITY ASSURANCE

- A. Quality assurance as required by Section 23 00 00, HVAC Basic Requirements and Division 01, General Requirements.
- B. In addition, meet the following:
 - 1. Formaldehyde Free: Should be third-party certified with UL Environment Validation.
 - 2. Recycled Content: A minimum of 40 percent post-consumer recycled glass content certified and UL validated.
 - 3. Low Emitting Materials: For all thermal and acoustical applications of Glass Mineral Wool Insulation products, provide materials complying with the testing and products requirements of UL GREENGUARD Gold Certification.
 - 4. Installer to have minimum 5 years' experience in the business of installing insulation.

1.6 WARRANTY

- A. Warranty of materials and workmanship as required by Section 23 00 00, HVAC Basic Requirements and Division 01, General Requirements.

1.7 FIRE HAZARD CLASSIFICATION

- A. Maximum fire hazard classification of the composite insulation construction as installed to be not more than a Flame Spread Index (FSI) of 25 and Smoke Developed Index (SDI) of 50 as tested by current edition of ASTM E84 (NFPA 255) method.
- B. Test pipe insulation in accordance with the requirements of current edition of UL "Pipe and Equipment Coverings R5583 400 8.15".
- C. Test duct insulation in accordance with current edition of ASTM E84, UL 723, NFPA 255, NFPA 90A and NFPA 90B.

PART 2 - PRODUCTS

2.1 MANUFACTURERS

- A. Type A, Flexible Glass Wool Blanket:
 - 1. Certainteed
 - 2. Johns Manville
 - 3. Knauf
 - 4. Owens-Corning
- B. Type B, Duct Liner:
 - 1. Certainteed
 - 2. Johns Manville
 - 3. Knauf
 - 4. Owens-Corning
- C. Type 1, Glass Wool Pipe Insulation:
 - 1. Certainteed

2. Johns Manville
3. Knauf
4. Owens-Corning

D. Type 2, Flexible Elastomeric Pipe Insulation:

1. Insulation:
 - a. Armacell LLC Armaflex
 - b. K-Flex
 - c. Or approved equivalent.
2. Glue:
 - a. Armacell LLC Armaflex Low VOC Adhesive
 - b. K-Flex
 - c. Or approved equivalent.
3. Paint:
 - a. Armacell LLC Armaflex
 - b. K-Flex
 - c. Or approved equivalent.

E. Jacketing:

1. ITW Insulation Systems
2. General Insulation Company
3. Or approved equivalent.

F. Accessories:

1. ITW Insulation Systems
2. Or approved equivalent.

G. Duct Insulation Accessories:

1. Certainteed
2. Johns Manville
3. Owens-Corning

H. Duct Insulation Compounds:

1. Certainteed
2. Johns Manville
3. Owens-Corning

I. Outdoor Ducting Cover:

1. Certainteed
2. Johns Manville
3. Owens-Corning

2.2 TYPE A, FLEXIBLE GLASS WOOL BLANKET

- A. ASTM C553, Type 1, Class B-2; flexible blanket.
- B. 'K' Value: 0.27 BTU*in/(hr*sf*F) at 75 degrees F installed, maximum service temperature: 250 degrees F.
- C. Density: 0.75 pounds per cubic foot.

- D. DBDE-free. UL/E validated to be formaldehyde-free.
- E. Vapor Barrier Jacket: FSK aluminum foil reinforced with glass wool yarn and laminated to fire resistant Kraft, secured with UL listed pressure sensitive tape or outward clinched expanded staples and vapor barrier mastic as needed.

2.3 TYPE B, DUCT LINER

- A. ASTM C1071; flexible blanket.
- B. 'K' Value: ASTM C518, 0.25 BTU*in/(hr*sf°F) at 75 degrees F, maximum service temperature: 250 degrees F.
- C. Noise Reduction Coefficient: 0.65 or higher based on ASTM C 423 "Type A mounting."
- D. Maximum Velocity on Mat or Coated Air Side: 5,000 FPM.
- E. Adhesive: UL listed waterproof type.
- F. Fasteners: Duct liner galvanized steel pins, welded or mechanically fastened.
- G. Erosion-Resistant Surfaces: UL 181.
- H. ASTM G21 and ASTM G22 Microbial Growth Resistance.
- I. UL GREENGUARD Certified does not support the growth of mold, fungi, or bacteria per ASTM C 1338 and meets UL Environment GREENGUARD Microbial Resistance Listing per UL 2824-"GREENGUARD Certification Program Method for Measuring Microbial Resistance". DBDE-free. UL/E validated to be formaldehyde-free.

2.4 TYPE 1, GLASS WOOL PIPE INSULATION

- A. Glass Wool: ASTM C547 Type I and IV; rigid molded, noncombustible.
 - 1. Thermal Conductivity Value: As indicated in the insulation tables below.
 - 2. Maximum Service Temperature: 850 degrees F to 1000 degrees F.
- B. Vapor Retarder Jacket: White Kraft paper reinforced with glass wool and bonded to aluminum foil, secure with self-sealing longitudinal laps and butt strips or vapor barrier mastic.

2.5 TYPE 2, FLEXIBLE ELASTOMERIC PIPE INSULATION

- A. Elastomeric Foam: ASTM C534; flexible, cellular elastomeric, molded or sheet.
 - 1. Thermal Conductivity Value: As indicated in the insulation tables below.
 - 2. Maximum Service Temperature of 220 degrees F.
 - 3. Maximum Flame Spread: 25.
 - 4. Maximum Smoke Developed: 50 (1-inch thick and below).
 - 5. Connection: Waterproof vapor retarder adhesive as needed.
 - 6. UV Protection: UV outdoor protective coating per manufacturer's requirements.
- B. Glue: Contact adhesive specifically manufactured for cementing flexible elastomeric foam.

- C. Paint: Nonhardening high elasticity type, specifically manufactured as protective covering of flexible elastomeric foam insulation for prevention of degradation due to exposure to sunlight and weather.

2.6 JACKETING

- A. Canvas Jacket: UL listed fabric, 6 ounce/sq.yd., plain weave cotton treated with dilute fire retardant lagging adhesive.
- B. PVC preformed molded insulation covers. Zeston or approved equivalent.
- C. Aluminum Jacket: 0.016-inch-thick sheet, (smooth/embossed) finish, with longitudinal slip joints and 2-inch laps, die-shaped fitting covers with factory attached protective liner.
- D. Stainless Steel Jacket: Type 304 stainless steel, 0.010-inch, smooth finish.
- E. Insulated Jacketing Tape: Venture Tape VentureClad Plus 1579CW Insulation Cladding, or approved equal.

2.7 ACCESSORIES

- A. Equipment Insulation Jacketing: Presized glass cloth, not less than 7.8 ounces/sq.yd., except as otherwise indicated. Coat with gypsum based cement.
- B. Equipment Insulation Compounds: Provide adhesives, cement, sealers, mastics and protective finishes as recommended by insulation manufacturer for applications indicated.
- C. General: Provide staples, bands, wire, wire netting, tape corner angles, anchors, stud pins and metal covers as recommended by insulation manufacturer for applications indicated. Accessories, i.e., adhesives, mastics, cements and tape to have the same flame and smoke component ratings as the insulation materials with which they are used. Shipping cartons to bear a label indicating that flame and smoke ratings do not exceed those listed above. Provide permanent treatment of jackets or facings to impart flame and smoke safety. Provide nonwater soluble treatments. Provide UV protection recommended by manufacturer for outdoor installation.

2.8 DUCT INSULATION ACCESSORIES

- A. Staples, bands, wires, tape, anchors, corner angles and similar accessories as recommended by insulation manufacturer for applications indicated.

2.9 DUCT INSULATION COMPOUNDS

- A. Cements, adhesives, coatings, sealers, protective finishes and similar accessories as recommended by insulation manufacturer for applications indicated.

2.10 OUTDOOR DUCTING COVER

- A. Aluminum Jacket: 0.016-inch-thick sheet, smooth/embossed finish, with longitudinal slip joints and 2-inch laps.

- B. Nonwater vapor retarder, nonburning, weatherproof coating for use over insulation where "breathing" is required.
- C. UV resistant polyvinyl chloride covering with joints secured and sealed.

PART 3 - EXECUTION

3.1 GENERAL INSTALLATION REQUIREMENTS

- A. Verification of Conditions:
 - 1. Do not apply insulation until pressure testing and inspection of ducts and piping has been completed.
 - 2. Examine areas and conditions under which duct and pipe insulation will be installed. Do not proceed with work until unsatisfactory conditions have been corrected.
- B. Preparation: Clean and dry surfaces to be insulated.
- C. Installation:
 - 1. Insulation: Continuous through walls, floors and partitions except where noted otherwise.
 - 2. Piping and Equipment:
 - a. Install insulation over clean, dry surfaces with adjoining sections firmly butted together and covering surfaces. Fill voids and holes. Seal raw edges. Install insulation in a manner such that insulation may be split, removed, and reinstalled with vapor barrier tape on strainer caps and unions. Do not install insulation until piping has been leak tested and has passed such tests. Do not insulate manholes, equipment manufacturer's nameplates, handholes, and ASME stamps. Provide beveled edge at such insulation interruptions. Repair voids or tears.
 - b. Cover insulation on pipes above ground, outside of building, with aluminum jacketing. Position seam on bottom of pipe.
- D. Provide accessories as required. See Part 2 Article "Accessories" above.
- E. Protection and Replacement: Installed insulation during construction. Replace damaged insulation which cannot be repaired satisfactorily, including units with vapor barrier damage and moisture saturated units.
- F. Labeling and Marking: Provide labels, arrows and color on piping and ductwork. Attach labels and flow direction arrows to the jacketing per Section 23 05 53, Identification for HVAC Piping, Ductwork and Equipment.
- G. Ductwork:
 - 1. Install insulation in conformance with manufacturer's recommendations to completely cover duct.
 - 2. Butt insulation joints firmly together and install jackets and tapes smoothly and securely.
 - 3. Apply duct insulation continuously through sleeves and prepared openings, except as otherwise specified. Apply vapor barrier materials to form complete unbroken vapor seal over insulation.
 - 4. Coat staples and seals with vapor barrier coating.

5. Cover breaks in jacket materials with patches of same material as vapor barrier. Extend patches not less than 2-inches beyond break or penetration on all directions and secure with adhesive and staples. Seal staples and joints with vapor barrier coating.
 6. Fill jacket penetrations. i.e., hangers, thermometers and damper operating rods, and other voids in insulation with vapor barrier coating. Seal penetration with vapor barrier coating. Insulate hangers and supports for cold duct in un-conditioned spaces to extent to prevent condensation on surfaces.
 7. Seal and flash insulation terminations and pin punctures with reinforced vapor barrier coating.
 8. Continue insulation at fire dampers and fire/smoke dampers up to and including those portions of damper frame visible at outside of the rated fire barrier. Insulating terminations at fire dampers in accordance with this Section.
 9. Do not conceal duct access doors with insulation. Install insulation terminations at access door in accordance with this Section.
- H. Insulated Pipe Exposed to Weather: Where piping is exposed to weather, cover insulation with aluminum jacket. Seal watertight jacket per manufacturer's recommendations. Install metal jacket with 2-inch overlap at longitudinal and butt joints with exposed lap pointing down. Secure jacket with stainless-steel draw bands 12-inches on center and at butt joints.
- I. Insulation Shields: Provide hangers and shields (18 gauge minimum) outside of insulation for cold piping (<60 degrees F). Hot water piping hangers may penetrate insulation to contact pipe directly. Provide 18-inch long, noncompressible insulation section at insulation shields for lines 2-inches and larger (hot and cold) piping.
- J. Ductwork Surfaces to be Insulated:

Item to be Insulated	System Insulation Type	Duct Size	Insulation Thickness
Supply ductwork where duct is not specified to be lined.	A	All	1.5-inch
Return ductwork where duct is not specified to be lined.	--	All	None
Supply ductwork (exposed to weather, in crawl space and in unheated attics)	A	All	3-inch
Return ductwork (exposed to weather, in crawl space and in unheated attics)	A	All	3-inch
Duct Silencers	C	All	1.5-inch
Outside Air Ducts	A	All	3-inch
HVAC plenums and unit housings not preinsulated	B	All	1.5-inch
Grease Exhaust	E	All	Per rating level

Exhaust ducts within 10-feet of exterior	A	All	3-inch
Exposed insulation in mechanical rooms or areas subject to damage	C, D	All	1.5-inch

- Note: Insulation thickness shown is a minimum. If state codes require additional thickness, then provide insulation thickness per code requirements.

K. Piping Surfaces to be Insulated:

Item to be Insulated	System Insulation Type	Conductivity Range (Btu-inch per hour per SF per degrees F)	Pipe Size (Inches)	Insulation Thickness (Inches)
Heating, Steam, and Steam Condensate (above 350F)	1, 4	0.32-0.34 at a mean rating temperature of 250 degrees F	<1	4.5
			1 to <1.5	5.0
			1.5 to <4	5.0
			4 to <8	5.0
			>= 8	5.0
Heating, Steam, and Steam Condensate (251F to 350F)	1, 4	0.29-0.32 at a mean rating temperature of 200 degrees F	<1	3.0
			1 to <1.5	4.0
			1.5 to <4	4.5
			4 to <8	4.5
			>= 8	4.5
Heating, Steam, and Condensate (201F to 250F)	1, 4	0.27-0.30 at a mean rating temperature of 150 degrees F	<1	2.5
			1 to <1.5	2.5
			1.5 to <4	2.5
			4 to <8	3.0
			>= 8	3.0

Heating, Steam, and Steam Condensate (141F to 200F)	1, 4	0.25-0.29 at a mean rating temperature of 125 degrees F	<1	1.5
			1 to <1.5	1.5
			1.5 to <4	2.0
			4 to <8	2.0
			>= 8	2.0
Heating, Steam, and Steam Condensate (105F to 140F)	1, 4	0.21-0.28 at a mean rating temperature of 100 degrees F	<1	1.0
			1 to <1.5	1.0
			1.5 to <4	1.5
			4 to <8	1.5
			>= 8	1.5
Chilled Water (40F to 60F)	1, 4	0.21-0.27 at a mean rating temperature of 75 degrees F	<1	0.5
			1 to <1.5	0.5
			1.5 to <4	1.0
			4 to <8	1.0
			>= 8	1.0
Chilled Water (<40F)	1, 4	0.20-0.26 at a mean rating temperature of 50 degrees F	<1	0.5
			1 to <1.5	1.0
			1.5 to <4	1.0
			4 to <8	1.0
			>= 8	1.5
Refrigerant Suction Piping (40F to 60F)	2	0.21-0.27 at a mean rating temperature of 75 degrees F	<1	0.5
			1 to <1.5	0.5
			1.5 to <4	1.0
			4 to <8	1.0
			>= 8	1.0

Refrigerant Suction Piping (<=40F)	2	0.20-0.26 at a mean rating temperature of 50 degrees F	<1	0.5
			1 to <1.5	1.0
			1.5 to <4	1.0
			4 to <8	1.0
			>= 8	1.5
Breeching, Generator Exhaust	3	0.52-0.58 at a mean rating temperature of 500 degrees F	All	4.0
Heating Water Storage and Air Separation Tanks	2, 5	0.24-0.28 at a mean rating temperature of 75 degrees F	N/A	2.0
Chilled Water Storage and Air Separation Tanks	2, 5	0.24-0.28 at a mean rating temperature of 75 degrees F	N/A	1.0
Heat Exchangers (Steam)	2, 5	0.24-0.28 at a mean rating temperature of 75 degrees F	N/A	4.0
Heat Exchangers (Hydronic)	2, 5	0.24-0.28 at a mean rating temperature of 75 degrees F	N/A	2.0
Condenser Water (Exterior)	1, 2, aluminum jacketing	0.21-0.27 at a mean rating temperature of 75 degrees F	1 to 6	1.0
			>=8	1.5

1. Note: Insulation thickness shown is a minimum. If state code requires additional thickness, then provide insulation thickness per code requirements.

3.2 TYPE A, FLEXIBLE GLASS WOOL BLANKET

- A. Install insulation in conformance with manufacturer's recommendations and requirements.
- B. Duct Wrap: Cover air ducts per insulation table except ducts internally lined where internal duct lining is adequate to achieve adequate insulating values to meet local Energy Codes (indicate on shop drawings, locations where duct wrap is planned to be omitted and indicate internal duct lining insulating values to confirm they will meet the Energy Code.) Wrap tightly with circumferential joints butted and longitudinal joints overlapped minimum of 2-inches. On ducts over 24-inches wide, additionally secure insulation with suitable mechanical fasteners at 18-inches on center. Circumferential and longitudinal joints stapled with flare staples 6-inches on center and covered with 3-inch wide, foil reinforced tape.

3.3 TYPE B, DUCT LINER

- A. Install insulation in conformance with manufacturer's recommendations and requirements.
- B. Duct Liners: Mat finish surface on air stream side. Secure insulation to cleaned sheet metal duct with continuous (minimum 90) percent coat of adhesive. Secure liner with mechanical fasteners 15-inches on center or per manufacturer requirements. Accurately cut liner and thoroughly coat ends with adhesive. Butt joints tightly. Top and bottom Sections of insulation overlap sides. Factory/field coat exposed edges. Metal nosing for exposed leading or transverse edges and when velocity exceeds 3500 FPM or manufacturer rating on exposed edges. Keep duct liner clean and free from dust. At completion of project, vacuum duct liner if it is dirty or dusty. Do not use small pieces. If insulation is installed without horizontal, longitudinal, and end joints butted together, installation will be rejected and work removed and replaced with work that conforms to this Specification.

3.4 TYPE 1, GLASS WOOL PIPE INSULATION

- A. See General Installation Requirements above.
- B. Install insulation in conformance with manufacturer's recommendations and requirements.
- C. Lap seal insulation with waterproof adhesive. Do not use staples or other methods of attachment which would penetrate vapor barrier. Apply fitting covers with seated tacks and vapor barrier tape.
- D. Apply insulation to pipe and seal with self-sealing lap. Use self-sealing butt strips to seal butt joints. Insulate fittings, valves and unions with single or multiple layers of insulation and cover to match pipe or use preformed PVC molded insulation covers.

3.5 TYPE 2, FLEXIBLE ELASTOMERIC PIPE INSULATION

- A. Flexible Elastomeric Insulation:
 - 1. Slip insulation on pipe prior to connection. Butt joints sealed with manufacturer's adhesive. Insulate fitting with miter-cut pieces. Cover insulation exposed to weather and below grade with two coats of finish as recommended by manufacturer.
- B. Flexible Elastomeric Tubing:
 - 1. Flexible Elastomeric Tubing: Slip insulation over piping or, if piping is already installed, slit insulation and snap over piping. Joints and butt ends must be adhered with 520 adhesive.
- C. See General Installation Requirements above.
- D. Install insulation in conformance with manufacturer's recommendations and requirements.
- E. Slip insulation on pipe prior to connection. Butt joints sealed with manufacturer's adhesive. Insulate fitting with miter-cut pieces. Cover insulation exposed to weather and undergrade with two coats of finish as recommended by manufacturer.
- F. Install in accordance with manufacturer's instructions for below grade installation.

3.6 JACKETING

- A. See General Installation Requirements above.
- B. Install in accordance with manufacturer's instructions.

3.7 ACCESSORIES

- A. Install insulation in conformance with manufacturer's instructions, recommendations and requirements.
- B. See General Installation Requirements above.
- C. Furnish and install accessories for all insulation types listed in this Section.

3.8 DUCT INSULATION ACCESSORIES

- A. Install insulation in conformance with manufacturer's recommendations and requirements.

3.9 DUCT INSULATION COMPOUNDS

- A. Install insulation in conformance with manufacturer's recommendations and requirements.

3.10 OUTDOOR DUCTING COVER

- A. Install insulation in conformance with manufacturer's recommendations and requirements.
- B. Outdoor Duct Exposed to Weather:
 - 1. Install jacket with brakes/slope to prevent standing water on duct. Use weatherable components.
 - 2. Weatherproof seal at joints and seams. Minimum 2-inch overlap.
 - 3. Label jacket every 6-feet and within 2-feet of building penetrations and equipment connections: "Do not stand or place equipment on duct."

END OF SECTION

SECTION 23 0800 - COMMISSIONING OF HVAC

PART 1 - GENERAL

1.1 SUMMARY

- A. Work Included:
 - 1. Definitions, warranties, test equipment requirements, and mechanical commissioning requirements.

1.2 RELATED SECTIONS

- A. Contents of Division 23, HVAC and Division 01, General Requirements apply to this Section.
- B. In addition, reference the following:
 - 1. Section 01 91 13, General Commissioning Requirements.

1.3 REFERENCES AND STANDARDS

- A. References and Standards as required by Section 23 00 00, HVAC Basic Requirements and Division 01, General Requirements.
- B. In addition, meet the following:
 - 1. Current edition of ASHRAE Guideline 0, The Commissioning Process.

1.4 SUBMITTALS

- A. Submittals as required by Section 23 00 00, HVAC Basic Requirements and Division 01, General Requirements.
- B. In addition, provide:
 - 1. Certificates of readiness.
 - 2. Certificates of completion of installation, prestart, and startup activities.
 - 3. Operation and Maintenance Manuals.
 - 4. Test reports.
 - 5. Control Drawings Submittal
 - a. Provide a key to abbreviations.
 - b. Provide graphic schematic depictions of the systems and each component.
 - c. Include the system and component layout of any equipment that the control system monitors, enables or controls, even if the equipment is primarily controlled by packaged or integral controls.
 - d. Provide a full points list with at least the following included for each point:
 - 1) Controlled system
 - 2) Point abbreviation
 - 3) Point description
 - 4) Display unit
 - 5) Control point or set point (Yes / No)
 - 6) Monitoring point (Yes / No)
 - 7) Intermediate point (Yes / No)
 - 8) Calculated point (Yes / No)

6. Architect forwards one set of submittals for systems to be commissioned to Commissioning Agent at same time as design team.
7. Commissioning Agent forwards comments to design team for consideration in their submittal response.
8. Design team sends consolidated response to submittals and copies to Commissioning Agent.

1.5 QUALITY ASSURANCE

- A. Quality assurance as required by Section 23 00 00, HVAC Basic Requirements and Division 01, General Requirements.
- B. Test Equipment Calibration Requirements: Contractors will comply with test manufacturer's calibration procedures and intervals. Recalibrate test instruments immediately after instruments have been repaired resulting from being dropped or damaged. Affix calibration tags to test instruments. Furnish calibration records to Commissioning Authority upon request.

1.6 WARRANTY

- A. Warranty of materials and workmanship as required by Section 23 00 00, HVAC Basic Requirements and Division 01, General Requirements.
- B. In addition, provide:
 1. Commissioning, inspecting, and testing will not modify terms or time periods of mechanical equipment, systems, and controls warranties including related equipment and systems, and adjacent work.
 2. Control system warranty period starts from date of Commissioning Agent acceptance.

1.7 COORDINATION

- A. Reference Section 01 91 13, General Commissioning Requirements, for requirements pertaining to coordination during the commissioning process.

1.8 PURPOSE

- A. Purpose of commissioning process is to provide Owner assurance that systems have been installed in prescribed manner and will operate within performance guidelines. Commissioning is intended to enhance quality of system startup and aid in orderly transfer of systems to beneficial use by Owner.
- B. Commissioning procedures and results will be observed by Commissioning Authority or Owner's staff. Contractor is expected to verify functional readiness of systems to be tested prior to performing the tests in presence of Owner's witness. A high rate of test failure will indicate that Contractor has not adequately verified readiness of systems.

PART 2 - PRODUCTS

2.1 TEST EQUIPMENT

- A. Provide standard testing equipment required to perform startup, initial checkout and functional performance testing for the equipment being tested. For example, the mechanical contractor of

Division 23, HVAC will ultimately be responsible for standard testing equipment for the HVAC&R system and controls system in Division 23, HVAC, except for the equipment specific to and used by TAB in their commissioning responsibilities. Provide a sufficient quantity of two-way radios by each subcontractor.

- B. Include special equipment, tools and instruments (specific to a piece of equipment and only available from vendor) required for testing in the base bid price to the Owner and leave on site, except for stand-alone data logging equipment that may be used by the Commissioning Authority.
- C. Manufacturer of equipment to provide proprietary test equipment and software required for programming and/or start-up, whether specified or not. Manufacturer provides the test equipment, demonstrates its use, and assists in the commissioning process as needed. Proprietary test equipment (and software) become the property of the Owner upon completion of the commissioning process.
- D. Data logging equipment and software required to test equipment will be provided by the Commissioning Authority, and will not become the property of the Owner.
- E. Use only testing equipment of sufficient quality and accuracy to test and/or measure system performance with the tolerances specified in the specifications. If not otherwise noted, the following minimum requirements apply: Temperature sensors and digital thermometers have a certified calibration within the past year to an accuracy of 0.5 degree F and a resolution of plus or minus 0.1 degree F. Pressure sensors have an accuracy of plus or minus 2.0 percent of the value range being measured (not full range of meter) and have been calibrated within the last year.

PART 3 - EXECUTION

3.1 GENERAL DOCUMENTATION REQUIREMENTS

- A. With assistance from the installing contractors, the Commissioning Authority will prepare prefunctional checklists for commissioned components, equipment, and systems
- B. Red-Lined Drawings:
 - 1. Verify equipment, systems, instrumentation, wiring and components are shown correctly on red-lined drawings.
 - 2. Preliminary red-lined drawings must be made available to the Commissioning Team for use prior to the start of Functional Performance Testing.
 - 3. Changes, as a result of Functional Testing, must be incorporated into the final as-built drawings, which will be created from the red-lined drawings.
 - 4. The contracted party, as defined in the Contract Documents will create the as-built drawings.
- C. Operation and Maintenance (O&M) Data:
 - 1. Contractor will provide a copy of O&M literature within 45 days of each submittal acceptance for use during the commissioning process for commissioned equipment and systems.
 - 2. The Commissioning Authority will review the O&M literature once for conformance to project requirements.

3. The Commissioning Authority will receive a copy of the final approved O&M literature once corrections have been made by the Contractor.

D. Demonstration and Training:

1. Contractor will provide demonstration and training as required by the specifications.
2. A complete training plan and schedule must be submitted by the contractor to the Commissioning Authority four weeks prior to any training.
3. A training agenda for each training session must be submitted to the Commissioning Authority one week prior the training session.
4. Notify the Commissioning Authority at least 72 hours in advance of scheduled tests so that testing may be observed by the Commissioning Authority and Owner's Authorized Representative. Provide a copy of the test record to the Commissioning Authority, Owner, and Architect.
5. Engage a factory-authorized service representative to train Owner's maintenance personnel to adjust, operate, and maintain specific equipment.
6. Train Owner's maintenance personnel on procedures and schedules for starting and stopping, trouble shooting, servicing, and maintaining equipment.
7. Review data in O&M Manuals.

E. Systems Manual Requirements:

1. The Systems Manual is intended to be a usable information resource containing the information related to the systems, assemblies, and Commissioning Process in one place with indexes and cross references.
2. Include final approved versions of the following information for the Systems Manual:
 - a. Facility Description.
 - b. Basis of Design (A/E).
 - c. A list of contractors, subcontractors, suppliers, architects, and engineers involved in the project along with their contact information.
 - d. Overview of each commissioned system including operational schedules and sequence of operations.
 - e. General maintenance recommendations and procedures.
 - f. Recommendations for recalibration frequency of sensors and actuators
 - g. Recommended best practices for keeping the system running efficiently.
 - h. Blank Functional Performance Tests so the Owner can recommission the facility at a later date.
3. Organize and arrange information by building system, such as fire alarm, chilled water, heating hot water, etc.
4. Provide Information in an electronic version to the extent possible. Legible, scanned images are acceptable for non-electronic documentation to facilitate this deliverable.

3.2 CONTRACTOR'S RESPONSIBILITIES

- A. Mechanical, Controls and TAB Contractors. The commissioning responsibilities applicable to each of the mechanical, controls and TAB contractors of Division 23, HVAC are as follows (references apply to commissioned equipment only):
1. Perform commissioning tests at the direction of the Commissioning Authority.
 2. Attend construction phase controls coordination meetings.
 3. Attend testing, adjusting, and balancing review and coordination meetings.
 4. Participate in HVAC&R systems, assemblies, equipment, and component maintenance orientation and inspection as directed by the Commissioning Authority.

5. Provide information requested by the Commissioning Authority for final commissioning documentation.
 6. Include requirements for submittal data, operation and maintenance data, and training in each purchase order or subcontract written.
 7. Prepare preliminary schedule for mechanical system orientations and inspections, operation and maintenance manual submissions, training sessions, pipe and duct system testing, flushing and cleaning, equipment start-up, testing and balancing and task completion for owner. Distribute preliminary schedule to commissioning team members.
 8. Update schedule as required throughout the construction period.
 9. During the startup and initial checkout process, execute the related portions of the prefunctional checklists for commissioned equipment.
 10. Contractor to participate and complete checklists using the Commissioning Authority's web based commissioning software Facility Grid. A desktop, laptop, tablet, or iPad will be required.
 11. Assist the Commissioning Authority in verification and functional performance tests.
 12. Gather operation and maintenance literature on equipment, and assemble in binders as required by the specifications. Submit to Commissioning Authority 45 days after submittal acceptance.
- B. Coordinate with the Commissioning Authority to provide 48 hour advance notice so that the witnessing of equipment and system start-up and testing can begin.
- C. Notify the Commissioning Authority a minimum of two weeks in advance of the time for start of the testing and balancing work. Attend the initial testing and balancing meeting for review of the official testing and balancing procedures.
- D. Participate in, and schedule vendors and contractors to participate in the training sessions.
- E. Provide written notification to the Construction Manager/General Contractor (CM/GC) and Commissioning Authority that the following work has been completed in accordance with the Contract Documents, and that the equipment, systems, and sub-system are operating as required.
1. HVAC&R equipment including fans, air handling units, ductwork, dampers, terminals, and other equipment furnished under this Division.
 2. Fire stopping in the fire rated construction, including fire and smoke damper installation, caulking, gasketing and sealing of smoke barriers.
 3. Fire detection and smoke detection devices furnished under other divisions of the specification.
- F. Equipment supplier to document the performance of his equipment.
- G. Test, Adjust and Balance Contractor:
1. Attend initial commissioning coordination meeting scheduled by the Commissioning Authority.
 2. Participate in verification of the testing and balancing report, which will consist of repeating measurements contained in the testing and balancing reports. Assist in diagnostic purposes when directed.
- H. Provide training of the Owner's operating staff using expert qualified personnel, as specified.

- I. Equipment Suppliers:
 - 1. Provide requested submittal data, including detailed start-up procedures and specific responsibilities of the Owner, to keep warranties in force.
 - 2. Assist in equipment testing per agreements with contractors.
 - 3. Provide information requested by Commissioning Authority regarding equipment sequence of operation and testing procedures.
- J. Reference Section 01 91 13, General Commissioning Requirements for additional contractor responsibilities.

3.3 OWNER'S RESPONSIBILITIES

- A. Reference Section 01 91 13, General Commissioning Requirements for Owner's Responsibilities.

3.4 DESIGN PROFESSIONAL'S RESPONSIBILITIES

- A. Reference Section 01 91 13, General Commissioning Requirements for Design Professional's Responsibilities.

3.5 COMMISSIONING AUTHORITY'S RESPONSIBILITIES

- A. Reference Section 01 91 13, General Commissioning Requirements for Commissioning Authority's Responsibilities.

3.6 TESTING PREPARATION

- A. Certify in writing to the Commissioning Authority that HVAC&R systems, subsystems, and equipment have been installed, calibrated, and started and are operating according to the Contract Documents.
- B. Certify in writing to the Commissioning Authority that HVAC&R instrumentation and control systems have been completed and calibrated, that they are operating according to the Contract Documents, and that pretest set points have been recorded.
- C. Certify in writing that testing, adjusting, and balancing procedures have been completed and that testing, adjusting, and balancing reports have been submitted, discrepancies corrected, and corrective work approved.
- D. Place systems, subsystems, and equipment into operating mode to be tested (e.g., normal shutdown, normal auto position, normal manual position, unoccupied cycle, emergency power, and alarm conditions).
- E. Inspect and verify the position of each device and interlock identified on checklists.
- F. Check safety cutouts, alarms, and interlocks with smoke control and life-safety systems during each mode of operation.
- G. Testing Instrumentation: Install measuring instruments and logging devices to record test data as directed by the Commissioning Authority.

3.7 TESTING, ADJUSTING AND BALANCING VERIFICATION

- A. Prior to performance of Testing, Adjusting and Balancing work, provide copies of reports, sample forms, checklists, and certificates to the Commissioning Authority.
- B. Notify the Commissioning Authority at least 10 days in advance of testing and balancing Work, and provide access for the Commissioning Authority to witness testing and balancing Work.
- C. Provide technicians, instrumentation, and tools to verify testing and balancing of HVAC&R systems at the direction of the Commissioning Authority.
 - 1. The Commissioning Authority will notify testing and balancing subcontractor 10 days in advance of the date of field verification. Notice will not include data points to be verified.
 - 2. Testing and balancing subcontractor to use the same instruments (by model and serial number) that were used when original data were collected.
 - 3. Failure of an item includes, other than sound, a deviation of more than 10 percent. Failure of more than 10 percent of selected items to result in rejection of final testing, adjusting, and balancing report. For sound pressure readings, a deviation of 3 dB to result in rejection of final testing. Variations in background noise must be considered.
 - 4. Remedy the deficiency and notify the Commissioning Authority so verification of failed portions can be performed.

3.8 GENERAL TESTING REQUIREMENTS

- A. Provide technicians, instrumentation, and tools to perform commissioning test at the direction of the Commissioning Authority.
- B. Scope of HVAC&R testing to include entire HVAC&R installation, from central equipment for heat generation and refrigeration through distribution systems to each conditioned space. Testing to include measuring capacities and effectiveness of operational and control functions.
- C. Test operating modes, interlocks, control responses, and responses to abnormal or emergency conditions, and verify proper response of building automation system controllers and sensors.
- D. The Commissioning Authority along with the HVAC&R contractor, testing and balancing Subcontractor, and HVAC&R Instrumentation and Control Subcontractor to prepare detailed testing plans, procedures, and checklists for HVAC&R systems, subsystems, and equipment.
- E. Tests will be performed using design conditions whenever possible.
- F. Simulated conditions may need to be imposed using an artificial load when it is not practical to test under design conditions. Before simulating conditions, calibrate testing instruments. Provide equipment to simulate loads. Set simulated conditions as directed by the Commissioning Authority and document simulated conditions and methods of simulation. After tests, return settings to normal operating conditions.
- G. The Commissioning Authority may direct that set points be altered when simulating conditions is not practical.
- H. The Commissioning Authority may direct that sensor values be altered with a signal generator when design or simulating conditions and altering set points are not practical.

- I. If tests cannot be completed because of a deficiency outside the scope of the HVAC&R system, document the deficiency and report it to the Owner. After deficiencies are resolved, reschedule tests.
- J. If the testing plan indicates specific seasonal testing, complete appropriate initial performance tests and documentation and schedule seasonal tests.

3.9 HVAC&R SYSTEMS, SUBSYSTEMS, AND EQUIPMENT TESTING PROCEDURES

- A. Equipment Testing and Acceptance Procedures: Testing requirements are specified in individual Division 23, HVAC Sections. Provide submittals, test data, inspector record, and certifications to the Commissioning Authority.
- B. HVAC&R Instrumentation and Control System Testing: Field testing plans and testing requirements are specified in Division 23, HVAC Sections "Instrumentation and Control for HVAC" and "Sequence of Operations for HVAC Controls." Assist the Commissioning Authority with preparation of testing plans.
- C. Pipe System Cleaning, Flushing, Hydrostatic Tests, and Chemical Treatment: Test requirements are specified in Division 23, HVAC Piping Sections. HVAC&R Contractor to prepare a pipe system cleaning, flushing, and hydrostatic testing plan. Provide cleaning, flushing, testing, and treating plan and final reports to the Commissioning Authority. Plan to include the following:
 1. Sequence of testing and testing procedures for each section of pipe to be tested, identified by pipe zone or sector identification marker. Markers keyed to Drawings for each pipe sector, showing the physical location of each designated pipe test section. Provide drawings keyed to pipe zones or sectors formatted to allow each section of piping to be physically located and identified when referred to in pipe system cleaning, flushing, hydrostatic testing, and chemical treatment plan.
 2. Description of equipment for flushing operations.
 3. Minimum flushing water velocity.
 4. Tracking checklist for managing and ensuring that pipe sections have been cleaned, flushed, hydrostatically tested, and chemically treated.
- D. The work included in the commissioning process involves a complete and thorough evaluation of the operation and performance of components, systems and sub-systems. Evaluate the following equipment and systems:
 1. HVAC Equipment and Systems (all)
 2. Boiler
 3. Building Automation System
 4. Chilled Water System
 5. Computer Room AC
 6. Domestic Hot Water Systems
 7. Renewable Energy Systems
 8. Pumps
 9. VFDs

3.10 DEFICIENCIES/NONCONFORMANCE, COST OF RETESTING, FAILURE DUE TO MANUFACTURER DEFECT

- A. Reference Division 01, General Requirements for requirements pertaining to deficiencies/nonconformance, cost of retesting, or failure due to manufacturer defect.

3.11 OPERATION AND MAINTENANCE MANUALS

- A. The Operation and Maintenance Manuals to conform to Contract Documents requirements as stated in Division 23, HVAC.
- B. Provide an updated as-built version of the control drawings and sequences of operation in the final controls O&M manual submittal.

3.12 TRAINING OF OWNER PERSONNEL

- A. Mechanical Contractor's Training Responsibilities:
 1. Provide the Commissioning Authority with a training plan two weeks before the planned training.
 2. Provide designated Owner personnel with comprehensive orientation and training in the understanding of the systems and the operation and maintenance of each piece of HVAC equipment including, but not limited to, HVAC equipment (i.e., pumps, heat exchangers, chillers, heat rejection equipment, air conditioning units, air handling units, fans, terminal units, controls and water treatment systems, etc.).
 3. Training starts with classroom sessions followed by hands-on training on each piece of equipment to illustrate the various modes of operation, including startup, shutdown, fire/smoke alarm, power failure, etc.
 4. During any demonstration, should the system fail to perform in accordance with the requirements of the O&M manual or sequence of operations, the system will be repaired or adjusted as necessary and the demonstration repeated.
 5. The appropriate trade or manufacturer's representative provides the instructions on each major piece of equipment. This person may be the start-up technician for the piece of equipment, the installing contractor or manufacturer's representative. Practical building operating expertise as well as in-depth knowledge of modes of operation of the specific piece of equipment are required. More than one party may be required to execute the training.
 6. Controls contractor to attend sessions other than the controls training, as requested, to discuss the interaction of the controls system as it relates to the equipment being discussed.
 7. The training sessions follow the outline in the Table of Contents of the operation and maintenance manual and illustrate whenever possible the use of the O&M manuals for reference.
 8. Training Includes:
 - a. Use of the printed installation, operation and maintenance instruction material included in the O&M manuals.
 - b. A review of the written O&M instructions emphasizing safe and proper operating requirements, preventative maintenance, special tools needed and spare parts inventory suggestions. Training to include start-up, operation in all modes possible, shut-down, seasonal changeover and any emergency procedures.

- c. Discussion of relevant health and safety issues and concerns.
 - d. Discussion of warranties and guarantees.
 - e. Common troubleshooting problems and solutions.
 - f. Explanatory information included in the O&M manuals and the location of plans and manuals in the facility.
 - g. Discussion of any peculiarities of equipment installation or operation.
9. Schedule training after functional testing is complete, unless approved otherwise by the Owner.

B. Controls Contractor's Training Responsibilities:

1. Provide the Commissioning Authority and A/E with a training plan four weeks before the planned training.
2. Provide designated Owner personnel training on the control system in this facility. The intent is to clearly and completely instruct the Owner on the capabilities of the control system.
3. Training manuals. The standard operating manual for the system and any special training manuals will be provided for each trainee, with three extra copies left for the O&M manuals. In addition, copies of the system technical manual will be demonstrated during training and three copies submitted with the O&M manuals. Manuals include detailed description of the subject matter for each session. Manuals to cover control sequences and have a definitions section that fully describes relevant words used in the manuals and in software displays. Manuals will be approved by the Commissioning Authority and A/E. Deliver copies of audiovisuals to the Owner.
4. The trainings will be tailored to the needs and skill-level of the trainees.
5. The trainers will be knowledgeable on the system and its use in buildings. For the on-site sessions, the most qualified trainer(s) will be used. Owner to approve the instructor prior to scheduling the training.
6. During any demonstration, should the system fail to perform in accordance with the requirements of the O&M manual or sequence of operations, the system will be repaired or adjusted as necessary and the demonstration repeated.
7. Attend sessions other than the controls training, as requested, to discuss the interaction of the controls system as it relates to the equipment being discussed.
8. Three Training Sessions, as Follows:
 - a. Training I - Control System. The first training consists of eight hours of actual training. This training may be held on-site or in the supplier's facility. If held off-site, the training may occur prior to final completion of the system installation. Upon completion, each student, using appropriate documentation, should be able to perform elementary operations and describe general hardware architecture and functionality of the system.
 - b. Training II - Building Systems. The second session held on-site for a period of eight hours of actual hands-on training after the completion of system commissioning. The session includes instruction on:
 - 1) Specific hardware configuration of installed systems in this building and specific instruction for operating the installed system, including HVAC systems, lighting controls and any interface with security and communication systems.
 - 2) Security levels, alarms, system start-up, shut-down, power outage and restart routines, changing set points and alarms and other typical changed parameters, overrides, freeze protection, manual operation of equipment, optional control strategies that can be considered, energy savings strategies

- and set points that if changed will adversely affect energy consumption, energy accounting, procedures for obtaining vendor assistance, etc.
- 3) Trending and monitoring features (values, change of state, totalization, etc.), including setting up, executing, downloading, viewing both tabular and graphically and printing trends. Trainees will actually set-up trends in the presence of the trainer.
 - 4) Completely discuss every screen, allowing time for questions.
 - 5) Use of keypad or plug-in laptop computer at the zone level.
 - 6) Use of remote access to the system via phone lines or networks.
 - 7) Setting up and changing an air terminal unit controller.
 - 8) Graphics generation.
 - 9) Point database entry and modifications.
 - 10) Understanding DDC field panel operating programming (when applicable).
- c. Training III - The third training will be conducted on-site six months after occupancy and consist of eight hours of training. The session will be structured to address specific topics that trainees need to discuss and to answer questions concerning operation of the system.

END OF SECTION

SECTION 23 0913 - VARIABLE FREQUENCY DRIVES

PART 1 - GENERAL

1.1 SUMMARY

- A. Work Included:
 - 1. Variable Frequency Drive
 - 2. Protection Circuits
 - 3. Display and Control Interface
 - 4. Adjustments

1.2 RELATED SECTIONS

- A. Contents of Division 23, HVAC and Division 01, General Requirements apply to this Section.

1.3 REFERENCES AND STANDARDS

- A. References and Standards as required by Section 23 00 00, HVAC Basic Requirements and Division 01, General Requirements.
- B. In addition, meet the following:
 - 1. Current edition of IEEE Standard 519, Recommended Practices and Requirements for Harmonic Control in Electrical Power Systems.
 - 2. Current edition of UL 508, Industrial Control Equipment.
 - 3. Current edition of NEMA ICS 7, Industrial Control and Systems: Adjustable-Speed Drives; National Electrical Manufacturers Association, latest edition.
 - 4. Current edition of IEC 16800 parts 1, 2 and 3
 - 5. Current edition of NEC 430.120, Adjustable-Speed Drive Systems.

1.4 SUBMITTALS

- A. Submittals as required by Section 23 00 00, HVAC Basic Requirements and Division 01, General Requirements.
- B. In addition, provide:
 - 1. Product Data: Indicate voltage, controller size, ratings and size of switching and overcurrent protection devices, short circuit ratings, dimensions, weights and enclosure details.
 - 2. Shop Drawings: Indicate front and side views of enclosures with overall dimensions and weights shown; conduit entrance locations and requirements; and name plate legends.
 - 3. Test Reports: Subject VFD to preliminary functional test, and final test at 104 degrees F, at full rated load. Indicate field test and inspection procedures and test results.
 - 4. Manufacturer's Instructions: Include installation instructions for starting and operating controllers, and describe operating limits that may result in hazardous or unsafe conditions.
 - 5. Maintenance Data: Include routine preventive maintenance schedule.
 - 6. Rated input: Maximum electric load rating in amperes and line reactor impedance.

1.5 QUALITY ASSURANCE

- A. Quality assurance as required by Section 23 00 00, HVAC Basic Requirements and Division 01, General Requirements.
- B. In addition, meet following:
 - 1. Qualifications:
 - a. Provide VFDs and options UL listed as a complete assembly. Base VFD UL listed for 100 KAIC without the need for input fuses.
 - b. CE Mark: VFD to meet product standard EN 61800-3 for the First Environment restricted level. (RFI/EMI Filter specification.)
 - c. Entire VFD enclosure, including the bypass, seismically certified and labeled in accordance with the International Building Code:
 - 1) VFD manufacturer to provide Seismic Certification and Installation requirements at time of submittal.
 - 2) Seismic importance factor of 1.5 rating is required, and based upon actual shake test data as defined by International Code Council AC-156.
 - 3) Seismic ratings based upon calculations alone are not acceptable. Certification of Seismic rating must be based on testing done in all three axis of motion by a certified lab.

1.6 WARRANTY

- A. Warranty of materials and workmanship as required by Section 23 00 00, HVAC Basic Requirements and Division 01, General Requirements.

PART 2 - PRODUCTS

2.1 MANUFACTURERS

- A. ABB
- B. Allen Bradley
- C. Cerus
- D. Danfoss
- E. Eaton
- F. Emerson
- G. General Electric
- H. Siemens
- I. Schneider Electric/Square D
- J. Toshiba

K. Yaskawa

L. Or approved equivalent.

2.2 VARIABLE FREQUENCY DRIVE

A. Description:

1. Variable Frequency Drive: Solid state, with Pulse Width Modulated (PWM) output waveform in a UL listed enclosure (enclosures with only NEMA ratings are not acceptable), completely assembled and tested by manufacturer. Employ full wave rectifier, AC or DC Line Reactor, capacitors, and Insulated Gate Bipolar Transistors (IGBTs) as output switching device.
2. Enclosure: UL rated and UL listed as a plenum rated VFD with NEMA 1 enclosure (indoors), NEMA 3R (outdoors), NEMA 12 (for indoor dusty locations), NEMA 8 (hazardous, Class I, Div I) and NEMA 9 (Class II, Div I). Manufacturers standard enamel.
3. Drive manufacturer to supply the drive and necessary options specified. VFD's that are manufactured by a third party and "brand labeled" are not acceptable. Provide VFD's installed on this project from the same manufacturer.

B. Operating Requirements:

1. Rated Input Voltage: VAC as scheduled on drawings, plus or minus 10 percent, 3 phase, 48 to 63 Hz.
2. Rated Output Voltage: 0 to input voltage, 3 phase, 0 to 120 Hz.
3. Fundamental Power Factor: Between 1.0 and 0.97, lagging, over entire range of operating speed and load.
4. Minimum Efficiency at Full Speed and Full Load: 97 percent or better.
5. Volts Per Hertz Adjustment: Plus or minus 10 percent.
6. Current Adjustment: 60 to 110 percent or rated.
7. Acceleration Rate Adjustment: 0.5 to 300 seconds.
8. Deceleration Rate Adjustment: 1 to 300 seconds.
9. Transient protection against normal transients and surges in incoming power line.
10. Environmental Conditions: 32 degrees F to 104 degrees F at 4kHz switching frequency, 0 to 3000-feet above sea level, less than 95 percent RH, noncondensing. Circuit boards to have conformal coating.
11. Seismic Testing: Tested to ICC AS-156. Submit certificate of compliance.

C. Standard Features:

1. VFD's to have the same customer interface, including digital display, and keypad, regardless of horsepower rating. Provide removable keypad, capable of remote mounting and allow for uploading and downloading of parameter settings as an aid for start-up of multiple VFD's.
2. Fault Mode on Loss of Input:
 - a. Display fault.
 - b. Run at programmable preset speed as selected by user.
3. Utilize English digital display (code numbers are not acceptable). Digital Display: Three configurable lines of LCD display, backlit, adjustable contrast. Setup parameters, indications, faults, warnings, status indicators and other information in words without use of manual or cross reference table.

4. Automatic restart after overcurrent, overvoltage, undervoltage, or loss of input signal protective trip. Programmable number of restart attempts, trial time, and time between reset attempts.
5. Capable of starting into rotating load (forward or reverse) and accelerate or decelerate to setpoint without safety tripping or component damage (flying start).
6. Automatic extended power loss ride-through circuit.
7. Customer terminal strip isolated from line and ground.
8. Keypad Hand-Off-Auto switch. When in "Off" VFD will be stopped. When in "Auto" VFD will start via external contact closure and its speed will be controlled via external speed reference. When in "Hand" VFD will be controlled via keypad up and down arrows.
9. Safety Interlocks: Furnish terminals for remote contact to inhibit starting under both manual and automatic mode.
10. Input Line Reactor or DC Line Choke: Five percent impedance AC or DC, to reduce harmonics to power line and to add protection from AC line transients.
11. Output filters for VFD's located more than 350 conductor feet from motor served.
12. Optimized for 4 kHz carrier frequency to reduce motor noise.
13. Disconnecting Means: Include door interlocked, UL 508C listed circuit breaker or fused disconnect switch.
14. Control circuit transformer with fused primary and secondary circuits.
15. Motor overload protection: Fused disconnects and thermal overloads for each motor when serving multiple motors from one drive.
16. Input current rating of the VFD to be no more than 3 percent greater than the output current rating. VFD's with higher input current ratings require the upstream wiring, protection devices, and source transformers to be oversized per NEC 430.120.
17. VFD to provide a programmable loss-of-load (broken belt/broken coupling) Form-C relay output. Provide programmable drive to signal the loss-of-load condition via a keypad warning, Form-C relay output, and / or over the serial communications bus.

2.3 PROTECTION CIRCUITS

- A. Overload Rating: 110 percent of its variable torque current rating for 1 minute every 10 minutes at 104 degrees F, and 140 percent of its H torque current rating for 2 seconds every 15 seconds.
- B. 350 percent instantaneous overcurrent trip.
- C. 130 percent to 65 percent over and under voltage trip.
- D. Over temperature trip at 115 degrees F.
- E. Short circuit protection, either running or at start, for phase to phase and phase to ground faults, phase rotation insensitive.
- F. Adaptable Electronic Motor Overload (I²t).
- G. EMI/RFI Filters: VFD's to include EMI/RFI filters. Onboard filters to allow the entire VFD assembly to be CE Marked and the VFD to meet product standard EN 61800-3 for the First Environment restricted. No Exceptions.

- H. Orderly Shutdown: In event of any of above conditions, shutdown drive safely without component failure.

2.4 DISPLAY AND CONTROL INTERFACE

- A. Serial Communications:
 - 1. VFD to have an EIA-485 port as standard. Standard protocols: Modbus, Johnson Controls N2, Siemens Building Technologies FLN, and BACnet MS/TP. The use of third party gateways and multiplexers is not acceptable. Protocols “certified” by the governing authority (i.e. BTL Listing for BACnet).
- B. Display operating information at VFD and provide separate interface signal for Building Automation System (BAS) via communications port to display and control following:
 - 1. Frequency Output - Hz
 - 2. Output voltage - Volts
 - 3. Current - Amps
 - 4. Speed - RPM
 - 5. Runtime - Hours
 - 6. System Fault
 - 7. Input Speed Setpoint - RPM
 - 8. On/Off Control Signal
 - 9. Calculated Motor Power - percentage or kW
 - 10. kWh meter

2.5 ADJUSTMENTS

- A. Three programmable critical frequency lockout ranges.
- B. Two programmable analog inputs. Analog inputs to include filters programmable from 0.01 to 10 seconds to remove any oscillation in input signal.
- C. Six programmable digital inputs for maximum flexibility in interfacing with external devices.
- D. Three remote contacts for fault including on/off status, fault and future configuration.
- E. Two programmable analog outputs proportional to frequency, motor speed, output voltage, output current, or scalable parameter selected by Owner.
- F. Run permissive circuit: Provide a run permissive circuit for damper or valve control. Regardless of the source of a run command (keypad command, input contact closure, time-clock control, or serial communications), the VFD to provide a dry contact closure that will signal the damper to open (VFD motor does not operate). When the damper is fully open, a normally open dry contact (end-switch) to close. The closed end-switch is wired to a VFD digital input and allows VFD motor operation. Provide a minimum of two separate safety interlock inputs. When any safety is opened, the motor commanded to coast to stop and the damper commanded to close.
- G. The VFD control to include a programmable time delay for VFD start and a keypad indication that this time delay is active. A Form C relay output provides a contact closure to signal the VAV boxes open. This will allow VAV boxes to be driven open before the motor operates.

- H. The VFD to include a fireman's override input. Mode to override other inputs (analog/digital, serial communication, and keypad commands), except customer defined safety run interlocks, and force the motor to run at a preset speed or in a separate PID mode.

PART 3 - EXECUTION

3.1 GENERAL INSTALLATION REQUIREMENTS

- A. Install in accordance with manufacturers installation instructions. Maintain manufacturer's and NEC service clearances.
- B. Install on strut support stand and brace for seismic.
- C. Select and install overload heater elements in motor controllers to match installed motor characteristics.
- D. Power wiring completed by the contractor, to NEC code 430.122 wiring requirements based on the VFD input current.
- E. Factory certified service representative to supervise start-up in accordance with manufacturer's instructions.
- F. Make final adjustments to assure proper operation of load system. Demonstrate final set-up and programming to Owner.
- G. Test unit in modes of operation and demonstrate compliance with requirements. Replace damaged or malfunctioning controls and equipment.
- H. Adjust ramp times to provide stable control during the balancing and commissioning process.

END OF SECTION

SECTION 23 0933 - ELECTRIC AND ELECTRONIC CONTROL SYSTEM FOR HVAC

PART 1 - GENERAL

1.1 SUMMARY

A. Work Included:

1. Room Thermostats
2. Smoke Detection for Projects with a Building Fire Alarm System
3. Relays and Contactors
4. Transformers
5. Wiring
6. Damper Operators
7. Motorized Control Valves
8. Electric Valve Actuators

1.2 RELATED SECTIONS

- A. Contents of Division 23, HVAC and Division 01, General Requirements apply to this Section.
- B. In addition, reference the following:
 1. Power wiring per Division 26, Electrical.

1.3 REFERENCES AND STANDARDS

- A. References and Standards as required by Section 23 00 00, HVAC Basic Requirements and Division 01, General Requirements.

1.4 SUBMITTALS

- A. Submittals as required by Section 23 00 00, HVAC Basic Requirements and Division 01, General Requirements.
- B. In addition, provide:
 1. Drawings: complete control diagram, including written description of control sequences.
 2. Operation and Maintenance Manual: Include record wiring drawings showing installed condition and operating changes made during start-up.

1.5 QUALITY ASSURANCE

- A. Quality assurance as required by Section 23 00 00, HVAC Basic Requirements and Division 01, General Requirements.

1.6 WARRANTY

- A. Warranty of materials and workmanship as outlined in Section 23 00 00, HVAC Basic Requirements and Division 01, General Requirements.
- B. In addition, provide:
 1. Within 30 days prior to warranty expiration date, control supplier to visit job site and check calibration, operation, and adjustment of temperature, pressure and humidity

sensors, valves, dampers, thermostats and other devices installed by control supplier. Make repair or replacement of defective control equipment as required at no charge to Owner.

2. Submit letter to Architect certifying that this work has been completed.
3. Attach copy of service report signed by Owner's Authorized Representative.

PART 2 - PRODUCTS

2.1 MANUFACTURERS

- A. Room Thermostats:
 1. Trane Tracer
 2. Siemens
 3. Or approved equivalent.
- B. Duct/Spot-Type Smoke Detectors (Project with Fire Alarm System):
 1. See Division 28 for Products.
- C. Damper Operators:
 1. Trane Tracer
 2. Siemens
 3. Or approved equivalent.
- D. Motorized Control Valves:
 1. Trane Tracer
 2. Siemens
 3. Or approved equivalent.
- E. Electric Valve Actuators:
 1. Trane Tracer
 2. Siemens
 3. Or approved equivalent.

2.2 BUILDING MANAGEMENT SYSTEM

- A. System Description
 1. Control system referenced throughout specifications and drawings as Building Management System (BMS), Building Automation System (BAS), or Energy Management System (EMS) interchangeably consists of high-speed, peer-to-peer network of DDC controllers, control system server, and/or operator workstation. System to be UUKL listed if used for smoke control.
 2. Control system server and/or operator workstation provides for overall system supervision and configuration, graphical user interface, management report generation, and alarm annunciation.
 3. System supports web browser access to building data. Remote user using standard web browser be able to access control system graphics and change adjustable set points with proper password.
 4. Local Area Network (LAN) either 10 or 100 Mbps Ethernet network
 5. System will consist of open architecture that is capable of:
 - a. Web-enabled system connecting all HVAC equipment indicated on the drawings.

- 1) High speed Ethernet communication using TCP/IP protocol
- 2) Access to system via any mobile phone or computer shall not require any dedicated server or project specific hardware.
- 3) Native BACnet communications according to ANSI / ASHRAE™ Standard 135-2004.
- 4) Provide necessary BACnet-compliant hardware and software to meet the system's functional specifications. Controller devices must be BTL tested and listed by an official BACnet Testing Laboratory and have the BTL mark issued.

B. Operator Interface

1. Local Operator Interface:

- a. A wall mounted touch screen display, or similar device, shall be provided to allow local access to the BMS.

- 1) Display shall provide a single point of control from which set point for multiple pieces of equipment can be changed.
- 2) Equipment operation and setpoint scheduling shall be via the interface.
- 3) Include pin (password) control and temperature adjustments.

- b. Building Operator Interface:

- 1) The operator interface shall be accessible via a web browser and shall not require any “plug-ins”.
- 2) Support of the following internet browsers:
 - (a) Chrome
 - (b) Safari
 - (c) Internet Explorer
 - (d) Firefox
- 3) Support for the following mobile operating systems:
 - (a) iOS (iPhone/iPad)
 - (b) Android (Phone/Tablet)

- c. Mobil App Operator Interface

- 1) The operator interface shall support system access to the following on a mobile device application (app):
 - (a) System Status
 - (b) Space Status
 - (c) Equipment Status
 - (d) Equipment Graphics
 - (e) Alarm Log
- 2) The operator interface shall support the following actions on a mobile device application (app):
 - (a) Override set points
 - (b) Override occupancy and/or schedule
 - (c) Acknowledge alarms

- d. System Applications: Provide following applications at each controller:

- 1) Database Save and Restore: System operator shall be able to save the database. If desired the operator shall also be able to clear the database and initiate download of specified database from/to any panel.
- 2) System Configuration: Controller software provides method of configuring system to allow for changes or additions by users and performs following tasks:

- (a) Create, delete or modify control strategies.
 - (b) Add/delete objects to system.
 - (c) Tune control loops through adjustment of control loop parameters.
 - (d) Enable or disable control strategies.
 - (e) Select points to be alarmed and define alarm state.
 - (f) Select points to be trended and initiate automatic recording of values.
 - (g) Start/Stop binary objects and adjust analog objects.
- 3) Security: Operator required to log on to system with user name and password in order to view, edit, add, or delete data. System security selectable for each operator.
 - 4) System Diagnostics: System automatically monitor operation of all network connections, building management panels, and controllers. Failure of any device to be annunciated to the operators.
 - 5) Alarm Indication and Handling:
 - (a) Controller provides visual means of alarm indication. Alarm indication becomes highest priority regardless of application(s) running.
 - (b) System provides and archive log of alarm messages to hard drive. Alarm messages to include description of event-initiating object, source, location and time/date of alarm.
 - 6) Trend Logs: Operator able to define custom trend log for any data object and include interval, start time, and stop time. Trend data sampled and stored on building controller panel, be archived on hard disk, and be retrievable for use in spreadsheets and standard database programs.
 - (a) Operator shall be able to view trend data in text-based (time-stamp/value) format.
 - (b) Operator interface is capable of graphing the trend logged object data. Software capable of creating two-axis (x,y) graphs that display object values relative to time.
 - (c) Operator able to change trend log setup information. This includes the information to be logged as well as the interval at which it is to be logged. Input, output, and value object types in the system may be logged. Provide operations password protected. Setup and viewing may be accessed directly from any and all graphics on which object is displayed.
 - (d) BMS Contractor to enable trending for any and all system points (physical or virtual) as directed by the Engineer, Owner or Commissioning Authority (Commissioning Authority). There will be no limit on the number of trended points the BMS Contractor is to set up. BMS Contractor will modify trend setup parameters as directed by the Commissioning Authority during testing. BMS Contractor to be proactive and enable trending for all major system points during system startup/programming. BMS Contractor is not to wait for direction to begin trending points. Trend data for each point to be archived on the main server for a minimum of one year. Trend data archiving to be enabled immediately upon trend setup, or as soon as communication between the field panel and sever is established. Trend data uploads from field panel to server set up to be automatically performed with sufficient frequency to ensure no data gaps or loss of trend data.

- 7) Standard Reports: Standard system reports provided for this project. Provide ability for Owner to readily customize these reports for this project:
 - (a) Objects: System (or subsystem) objects and their current values.
 - (b) Logs:
 - (1) Alarm History
 - (2) System Messages
 - (3) System Events
 - (4) Trends
- 8) Interfaces to Third Party Systems: BMS connects to third party systems (VFDs, rooftop AC units, VRF system, etc.). Communication protocol specified for third party system, and BMS provides compatible protocol to assure proper two way communication. Points, alarms, and commands displayed on BMS as indicated.

C. Controller Software

1. Furnish following applications software for building and energy management. Software applications reside and operate in system controllers. All software to be manufacturer's most current version at the time of installation. All software and associated functions (scheduling, optimum start/stop, etc.) noted in this specification are to be configured and enabled for this project. Incorporate into sequence of operation submittals for review prior to installation.
2. System Security:
 - a. User access secured using individual security passwords and user names.
 - b. Restrict user passwords to objects, applications, and system functions as assigned by system manager.
 - c. Record user Log On/Log Off attempts.
 - d. Provide passwords, user names, and access assignments adjustable at the operator's terminal.
 - e. System to include an Auto Logout Feature that will automatically logout user when there has been no activity for a set period of time. Time period to be adjustable by system administrator. Auto Logout may be enabled and disabled by system administrator. Operator terminal to display message on screen that user is logged out after Auto Logout occurs.
3. Scheduling: Provide capability to schedule each object or group of objects in system. Coordinate schedule with Owner and program accordingly. Each schedule consists of:
 - a. Operator's workstation to show information in easy-to-read daily format. Priority for scheduling: Events, holidays and daily with events being the highest.
 - b. Holiday and special event schedules to display data in calendar format. Operator able to schedule holidays and special events directly from these calendars.
 - c. All holiday and special even schedules shall override the standard schedule for that day(s) of the week.
 - d. Operator able to change information for a given weekly or exception schedule if logged on with the appropriate security access.
 - e. Provide separate schedules for each day of the week.
4. Optimum Start/Stop: Provide software and program system to start equipment on sliding schedule based upon indoor and outdoor conditions. Determine minimum time of HVAC system operation needed to satisfy space environmental requirements and also determine earliest possible time to stop mechanical systems (i.e. shut down cooling/heating one hour prior to scheduled unoccupied period.) Optimum start/stop program operates in conjunction with scheduled start/stop and night setback programs.

5. Alarms:
 - a. Controller to provide visual means of alarm indication. The alarm dialog box to always become the top dialog box regardless of the application(s), currently running.
 - b. System to provide log of alarm messages. Alarm log to be archived to the hard disk of the system operator's terminal. Each entry to include a description of the event-initiating object generating the alarm. Entry to include time and date of alarm occurrence.
 - c. Alarm messages in user-definable text and entered either at the operator's terminal or via remote communication.
 - d. Alarms must be able to be automatically and manually disabled.
 - e. An alarm shall be capable of triggering any of the following actions:
 - 1) Route an e-mail message to an operator(s)
 - 2) Route the alarm to an alarm log
 - 3) Run a custom control program.
 6. Maintenance Management: System monitors equipment status and generate maintenance messages based upon user-designated run-time, starts, and/or calendar date limits. Coordinate settings with Owner.
 7. Sequencing: Provide application software based upon sequences of operation specified to properly sequence designated systems. Provide all points to achieve specified sequences.
 8. Staggered Start: This application prevents controlled equipment from simultaneously restarting after a power outage. Order in which equipment (or groups of equipment) is started, along with time delay between starts to be user-selectable.
 9. Energy Calculations: Provide software to allow instantaneous power (e.g. kW) or flow rates (e.g. L/s (gpm)) to be accumulated and converted to energy usage data.
 10. Anti-Short Cycling: Binary output objects protected from short cycling by allowing minimum on-time and off-time to be selected.
 11. On/Off Control with Differential: Provide algorithm that allows binary output to be cycled based on controlled variable and set point. Algorithm direct-acting or reverse-acting and incorporate adjustable differential.
 12. Run-Time Totalization: Provide software to totalize run-times for binary input objects.
- D. Web Based Access
1. General Description: BMS supplier to provide web-based access to the system as part of standard installation. Provide access to user of displays of real-time data that are part of the BMS via a standard Web browser. Web browser to tie into the network via Ethernet network connection. Provide web-page host that resides on the BMS network. Web-page software not to require a per user licensing fee or annual fees. The web-page host must be able to support at least 50 simultaneous users with the ability to expand the system to accommodate an unlimited number of users. Software to be manufacturer's most current version at time of installation.
 2. Browser Technology: No special vendor-supplied software needed on computers running browser. Displays viewable and the Web-page host to directly access real-time data from the BMS network. Data displayed in real time and update automatically without user interaction. User able to change data on displays if logged in with the appropriate user name and password.
 3. Display of Data: Web page graphics shown on browser to be replicas of the BMS displays. User to need no additional training to understand information presented on Web pages when compared to what is shown on BAS displays. Web page displays to include animation just as BMS displays. Fans to turn, pilot lights to blink, and coils to change

colors, and so on. Real-time data shown on browser Web pages. This data must be directly gathered via the BACnet network and automatically updated on browser Web page displays without any user action. Data on the browser to automatically refresh as changes are detected without re-drawing the complete display. User to be able to change data from browser Web page to if the user is logged on with the appropriate password. Clicking on a button or typing in a new value to change digital data. Using pull-down menus or typing in a new value to change analog data. Data displays navigated using pushbuttons on the displays that are simply clicked on with the mouse to select a new display. Alternatively, the standard back and forward buttons of the browser can be used for display navigation.

4. Password Security and Activity Log: Access via Web browser to utilize the same hierarchical security scheme as BMS system. User asked to log in once the browser makes connection to Web-page host. Once the user logs in, any and all changes that are made to be tracked by the BMS system. User able to change only those items that the user has authority to change. A user activity report to show any and all activity of the users that have logged in to the system regardless of whether those changes were made using a browser or via the BMS workstation.
5. Communication: Web-page host to communicate using the specified protocol standard to devices on the BMS network.

E. System Graphics

1. Operator interface shall be graphically based and shall include at least one graphic per piece of equipment or occupied zone and graphics that summarize conditions on each floor of each building.
2. Indicate thermal comfort on floor plan summary graphics using colors to represent zone temperature relative to zone set point.
3. Allow the operator to monitor system status, to view a summary data for each controlled zone or piece of equipment, to navigate between zones or equipment, and to edit set points and other parameters.
4. Use 3D images for all standard and custom graphics. The only allowable exceptions will be photo images, maps, schematic drawings, and selected floor plans.
5. Indicate areas or equipment in an alarm condition using color or other visual indicator.
6. Saved in an industry-standard format such as BMP, JPEG, PNG, or GIF. Web-based system graphics shall be viewable on browsers compatible with World Wide Web Consortium browser standards.

2.3 ROOM THERMOSTATS

A. Electronic Thermostat:

1. Seven day programmable, PI control.
2. Occupied/unoccupied heat and cool setpoints.
3. Automatic heat/cool changeover and fan control.
4. Touch screen display.
5. Cooling Stages: Provide as required to match in air conditioner.

B. Electric Thermostat: Wall mounted thermostat with heat anticipation, automatic changeover and standard Fahrenheit slide switch with thermometer 1 stage heat, 2 stage cooling. Heat/auto/cool and continuous fan switch.

- C. Line Voltage, Electric Heater Thermostat: Wall mounted thermostat, non-programmable, dial adjustment between 50 degrees F and 80 degrees F, white color.
- D. Line Voltage, Cooling Thermostat: Wall mounted thermostat, non-programmable, dial adjustment between 44 degrees F and 86 degrees F, gold color.
- E. Electronic BACnet Thermostat/Controller: Wall mounted, 24 VAC, LED display, up to three universal inputs, up to four outputs, dedicated temperature sensor, up to four pre-programmed control strategies.
- F. Provide opaque locking guards on new and existing thermostats. Provide matching key for covers.

2.4 SMOKE DETECTION (FOR PROJECTS WITH A FIRE ALARM SYSTEM)

- A. See Division 28 for Products.

2.5 RELAYS AND CONTACTORS

- A. Provide relays and contactors where required or as shown on Drawing to meet operating sequence where not internal to manufacturer's equipment.
- B. Furnish relays or contactors with required coil voltage and contact amperage rating for use specified on Drawing and in manufacturer's equipment.
- C. Mount relays in single control cabinet with hinge door and latch.
- D. Control cabinet contains relays and numbered terminal strips for connection of relays and field wiring. Mount cabinet on painted plywood panel securely attached to wall framing. Mount time clock, transformer and motor contactors (if required) on plywood adjacent to control panel.

2.6 TRANSFORMERS

- A. Transformers selected and sized for appropriate VAC capacity and installed and fused according to applicable codes. Provide wiring to nearest suitable power source as required.

2.7 WIRING

- A. In accordance with Division 26, Electrical and applicable codes.
- B. Provide line and low voltage wiring relating to control system. Includes wiring of contactors, relays, circuits, and incidental power wiring: operation power for time clock, power when run through stat/timeclock/relay, transformers.

2.8 DAMPER OPERATORS

- A. Size operators to operate dampers properly against system pressures, pressure differentials and velocities. Damper operators sized for 150 percent of damper forces normally encountered. Spring return closed for outside air applications.

2.9 MOTORIZED CONTROL VALVES

- A. Body pressure rating and connection type construction conforms to pipe, fitting and valve schedules.
- B. Fluid valve close-off ratings and spring ranges operates at maximum flows and maximum available pump heads scheduled without leakage.
- C. Screwed ends except 2-1/2-inch and larger valves with flanged ends.
- D. Fluid two-way modulating valves:
 - 1. 2-inches and smaller pressure independent valves as specified in Section 23 21 13, HVAC Piping.
 - 2. 2-1/2-inches and larger pressure independent Delta P valves as specified in Section 23 21 13, HVAC Piping.
 - 3. 2-inches and smaller fail-in-place characterized ball valves; ANSI 250 body rating; bronze body and stainless steel trim.
 - 4. 2-1/2-inch and larger cast iron ANSI Class 125, Other with guided equal percentage plug; PTFE packing.
- E. Fluid three-way valves globe valves with linear plug with composition disc for tight shutoff.
- F. Pressure drop equal to twice pressure drop through heat exchanger (load), 50 percent of pressure difference between supply and return mains, or 5 PSI, whichever is greater, except two-position valves be line size.
- G. Bubble-tight line size butterfly valves acceptable on 2-1/2-inch lines and above for two-position action only; cast iron body; aluminum bronze disc; EPDM seat, 200 PSI wg.
- H. For modulating service that require valve sizes above 6-inch, butterfly or v-port ball valves are allowed.

2.10 ELECTRIC VALVE ACTUATORS

- A. Provide mechanical or electronic stall protection for each actuator.
- B. Where indicated provide internal mechanical, spring-return mechanism or provide uninterruptible power supply (UPS). Non-spring-return actuators have external manual gear release to position damper/valve when actuator is not powered.
- C. Proportional actuators accepts 0 to 10 VDC or 0 to 20 mA control signal and provide 2 to 10 VDC or 4 to 20 mA operating range.
- D. Actuator sized for torque required plus 25 percent; UL or CSA listed; electronic current overload protection.
- E. Actuators for emergency generator damper control rated for 350 degree F. maximum operating temperature and capable to drive fully open and close within 15 seconds.

PART 3 - EXECUTION

3.1 SMOKE DETECTION (FOR PROJECTS WITH A FIRE ALARM SYSTEM)

- A. Smoke detector furnished and powered/wired under Division 28, Electronic Safety and Security. Coordinate with fire alarm equipment supplier. Installation of duct smoke detector housing and sampling tube under Division 23, HVAC.
- B. Install smoke detectors in return air systems greater than 2000 CFM.
- C. Install smoke detectors at each story prior to connection to return air riser in systems greater than 15,000 CFM and serving more than one story.

3.2 INSTALLATION OF AUXILIARY CONTROL DEVICES

- A. General:
 - 1. Install sensors and thermostats in accordance with manufacturer's recommendations.
 - 2. Room sensors and thermostats installed at 48-inches AFF to midline of sensor on concealed junction boxes properly supported by wall framing at the locations shown on the Drawings.
- B. Actuators:
 - 1. General:
 - a. Mount and link control damper actuators according to manufacturer's instructions.
 - b. Check operation of damper/actuator combination to confirm that actuator modulates damper smoothly throughout stroke to both open and closed positions.
 - 2. Actuator Mounting for Damper and Valve arrangements to comply to the following:
 - a. Damper Actuators: Do not install in the air stream.
 - b. Use a weather proof enclosure (clear and see through) if actuators are located outside.
 - c. Damper or valve actuator ambient temperature not-to-exceed 122 degrees F through any combination of medium temperature or surrounding air. Provide appropriate air gaps, thermal isolation washers or spacers, standoff legs, or insulation as necessary. Mount per manufacturer's recommendations.
 - d. Actuator cords or conduit to incorporate a drip leg if condensation is possible. Do not allow water to contact actuator or internal parts. Location of conduits in temperatures dropping below dew point to be avoided to prevent water from condensing in conduit and running into actuator.
- C. Control Valve:
 - 1. Valves installed in accordance with manufacturer's recommendations.
 - 2. Slip-stem control valves installed so that stem position is not more than 60 degrees from vertical up position. Ball type control valves installed with stem in horizontal position.
 - 3. Control valves accessible and serviceable.
 - 4. Install isolation valves so that control valve may be serviced without draining supply/return side piping system. Install unions at connections to screw-type control valves.
 - 5. Valve Sizing for Water Coil:
 - a. On/Off Control Valves: Line size.

- b. Modulating control valve body size may be reduced, at most, two pipe sizes from the line size or not less than 1/2 the pipe size. BAS contractor to size all water coil control valves for the application as follows:
 - 1) Booster-heat valves sized not-to-exceed 4-9 PSI differential pressure. Size valve for 50 percent valve authority. Valve design pressure drop is equal to the sum of coil drop plus the balance valve drop.
 - 2) Primary valves sized not-to-exceed 5-15 PSI differential pressure. Size valve for 50 percent valve authority. Valve design pressure drop is equal to the sum of coil drop plus the balance valve drop.
 - 3) Butterfly valves sized for modulating service at 60 to 70 degree rotation. Design velocity 12-feet per second or less when used with standard EPDM seats.
- 6. Valve Mounting arrangements to comply to the following:
 - a. Provide unions on all ports of two-way and three-way valves.
 - b. Install three-way equal percentage Characterized Control valves in a mixing configuration with the "A" port piped to the coil.
 - c. Install 2-1/2-inch and above, three-way globe valves, as manufactured for mixing or diverting service to the coil.

END OF SECTION

SECTION 23 2113 - HVAC PIPING

PART 1 - GENERAL

1.1 SUMMARY

- A. Work Included:
 - 1. Condenser Water Piping, Buried
 - 2. Condenser Water Piping, Above Ground
 - 3. Equipment Drains and Overflows
 - 4. Unions

1.2 RELATED SECTIONS

- A. Contents of Division 23, HVAC and Division 01, General Requirements apply to this Section.

1.3 REFERENCES AND STANDARDS

- A. References and Standards as required by Section 23 00 00, HVAC Basic Requirements and Division 01, General Requirements.

1.4 SUBMITTALS

- A. Submittals as required by Section 23 00 00, HVAC Basic Requirements and Division 01, General Requirements.
- B. In addition, provide:
 - 1. Welding Certificates: Copies of certificates for welding procedures and personnel.
 - 2. Field Test Reports: Written reports of tests specified in Part 3 of this Section. Include the following:
 - a. Test procedures used.
 - b. Test results that comply with requirements.
 - c. Failed test results and corrective action taken to achieve requirements.
 - 3. Water Analysis: Submit a copy of the water analysis to illustrate water quality available at project site.
 - 4. Buried piping manufacturer to submit thrust block (chilled water) and anchor plate (heating hot water) layout and details including anchorage and seismic calculations.

1.5 QUALITY ASSURANCE

- A. Quality assurance as required by Section 23 00 00, HVAC Basic Requirements and Division 01, General Requirements.
- B. In addition, meet the following:
 - 1. Installer Qualifications: Company specializing in performing work of the type specified in this Section, with documented experience.
 - 2. Welder Qualifications: Certify in accordance with ASME (BPV IX).
 - 3. ASME Compliance: Comply with ASME B31.9 "Building Services Piping" for materials, products, and installation. Provide safety valves and pressure vessels with the appropriate

ASME label. Fabricate and stamp air separators and expansion tanks to comply with the ASME Boiler and Pressure Vessel Code, Section VIII, Division 01.

1.6 WARRANTY

- A. Warranty of materials and workmanship as required by Section 23 00 00, HVAC Basic Requirements and Division 01, General Requirements, General Requirements.

PART 2 - PRODUCTS

2.1 CONDENSER WATER PIPING, BURIED

- A. Steel Pipe Smaller Than 12-inches: ASTM A 53/A 53M, Schedule 40, black with AWWA C105/A21.5 polyethylene jacket, or double layer, half-lapped polyethylene tape.
 - 1. Fittings: ASTM A 234/A 234M, wrought steel welding type with double layer, half-lapped polyethylene tape.
 - 2. Joints: Threaded for pipe 2-inch and under; AWS D1.1, welded for pipe over 2-inch.
- B. Steel Pipe Sizes 12-inch and Over: ASTM A 53/A 53M, 0.375-inch wall, black with AWWA C105/A21.5 polyethylene jacket, or double layer, half-lapped polyethylene tape.
 - 1. Fittings: ASTM A 234/A 234M, wrought steel welding type with double layer, half-lapped polyethylene tape.
 - 2. Joints: Welded in accordance with AWS D1.1.
- C. Copper Tube: ASTM B 88 (ASTM B 88M), Type K annealed.
 - 1. Fittings: ASME B16.22, wrought copper.
 - 2. Joints: Solder, lead free, 95-5 tin-antimony, or tin and silver.
- D. PVC Pipe Smaller than 8-inches: ASTM D 1785, Schedule 40, or ASTM D 2241, SDR 21 or 26.
 - 1. Fittings: ASTM D 2466 or ASTM D 2467, PVC.
 - 2. Joints: Solvent welded.
- E. PVC Pipe sizes 8-inch and larger: ASTM D 1785, Schedule 80, or ASTM D 2241, SDR 21 or 26.
 - 1. Fittings: ASTM D 2466 or ASTM D 2467, PVC.
 - 2. Joints: Solvent welded.
- F. HDPE Pipe Size 2-inch to 12-inch:
 - 1. Carrier Pipe: HDPE, ASTM-3350, SDR-11.
 - 2. Insulation: Closed cell polyurethane, thermal conductivity 0.16, ASTM C-591.
 - 3. Jacketing: HDPE, minimum wall thickness of 100 mils.
 - 4. Joints: Butt fusion welded.

2.2 CONDENSER WATER PIPING, ABOVE GROUND

- A. Grooved Mechanical Joint Fittings and Couplings - Approved Manufacturers:
 - 1. Tyco Grooved Piping Products
 - 2. Grinnell Corporation
 - 3. Shurjoint Piping Products

4. Or approved equivalent.
- B. Steel Pipe: ASTM A53/A 53M, Schedule 40, black, Type E (electric resistance welded), Grade B.
1. Fittings: ASME B16.3, malleable iron or ASTM A 234/A 234M, wrought steel welding type.
 2. Wrought Cast and Forged Steel Flanges and Flanged Fittings: ASME B16.5 including bolts, nuts, and gaskets of the following material group, end connections, and facings:
 - a. Material Group: 1.1.
 - b. End Connections: Butt welding.
 - c. Facings: Raised face.
 3. Joints: Threaded or AWS D1.1 welded.
- C. Grooved Mechanical Joint Fittings: ASTM A536, Grade 65-45-12 ductile iron; ASTM A47 (ASTM A47M), Grade 32510 malleable iron; ASTM A53, Type F, E, or S, Grade B fabricated steel; or ASTM A 106, Grade B steel fittings with grooves or shoulders designed to accept grooved end couplings.
1. Grooved Mechanical-Joint Couplings: Ductile or malleable iron housing and synthetic rubber gasket of central cavity pressure-responsive design for operating temperature range from -30 degrees F to 230 degrees F. Gasket material as recommended by manufacturer for design conditions.
- D. Copper Tube: ASTM B 88 (ASTM B 88M), Type L (B), drawn.
1. Fittings: ASME B16.18, cast brass, or ASME B16.22, solder wrought copper.
 2. Joints: Solder, lead free, ASTM B32, HB alloy (95-5 tin-antimony), or tin and silver.
 3. Joints: Brazed, AWS A5.8, Classification BAg-1 (silver). Pipes 2-1/2-inch or larger or piping routed over food preparation centers, food serving facilities, food storage areas, computer rooms, telecommunications rooms, and electrical rooms.

2.3 EQUIPMENT DRAINS AND OVERFLOWS

- A. Copper Tube: ASTM B 88 (ASTM B 88M), Type L (B), drawn.
1. Fittings: ASME B16.18, cast brass, or ASME B16.22 solder wrought copper.
 2. Joints: Solder, lead free, ASTM B 32, HB alloy (95-5 tin-antimony), or tin and silver.
 3. Joints: Brazed, AWS A5.8, Classification BAg-1 (silver). Pipes 2-1/2-inch or larger or piping routed over food preparation centers, food serving facilities, food storage areas, computer rooms, telecommunications rooms, and electrical rooms.

2.4 UNIONS

- A. Unions for Pipe 2-inches and Under:
1. Ferrous Piping: 150, 250, and 300 PSIG malleable iron, threaded, ASME B16.39.
 2. Copper Pipe: Bronze, soldered joints, ASME B16.22.
- B. Dielectric Connections: Provide dielectric waterway or brass nipple fitting with threaded ends. Dielectric unions are not allowed.

PART 3 - EXECUTION

3.1 GENERAL INSTALLATION REQUIREMENTS

- A. Install per manufacturer's written instructions and requirements.
- B. Preparation:
 - 1. Ream pipe and tube ends. Remove burrs. Bevel plain end ferrous pipe.
 - 2. Remove scale and dirt on inside and outside before assembly.
 - 3. Prepare piping connections to equipment with flanges or unions.
 - 4. Keep open ends of pipe free from scale and dirt. Protect open ends with temporary plugs or caps.
- C. Buried Piping Installation:
 - 1. Install in accordance with Drawings, specifications, and manufacturer's installation instructions. Provide a field service instructor on site to train the Contractor in all phases of installation.
 - 2. Underground Systems: Buried in a trench of not less than 2-feet deeper than the top of the pipe and not less than 18-inches wider than the combined outside diameter of all piping systems. A minimum thickness of 24-inches of compacted backfill over the top of the pipe is required. System installation must meet H-20 highway loading.
 - 3. Trench bottom to have a minimum of 6-inch of sand, pea gravel, or specified backfill material, as approved by the engineer, as a cushion for the piping. Field cutting of the pipe performed in accordance with the manufacturer's installation instructions.
 - 4. Provide thrust blocking, anchor plates, and concrete.
 - 5. Cast a concrete block over anchor plates as recommended by manufacturer. Block to sit on undisturbed trench sidewalls and/or the bottom of the trench. Concrete block to be at least the length as recommended by manufacturer and extend a minimum distance as recommended by manufacturer beyond the top and bottom of anchor plate.
 - 6. Pressure test buried piping.
 - 7. Field Service: Provided by a certified manufacturer's representative or company field service technician. The technician will be available at the job to check unloading, storing, and handling of pipe, joint installation, pressure testing and backfilling techniques.
 - 8. Provide identification and tracer wire, per Section 23 0553, Identification for HVAC Piping, Ductwork and Equipment.
 - 9. Clean piping systems thoroughly. Purge pipe of construction debris and contamination before placing the piping systems in service. Provide temporary connections for cleaning, purging, and circulating fluids through the piping system.
 - 10. Use temporary strainers and temporary pumps that can create fluid velocities up to 10 feet per second to flush and clean the piping systems. Do not use Owner's permanent strainers to trap debris during pipe flushing operations. Fit the temporary construction strainers with a line size blowoff valve.
 - 11. When constructing minor piping modifications or additions, verify with Owner if the Owner's pumps and strainers can be used for flushing and chemical cleaning operations. When the flushing and cleaning operations are complete, ensure the strainer baskets and screens installed in the piping systems permanent strainers are replaced with clean elements. Keep temporary strainers in service until the equipment has been tested, then replace straining element with a new strainer and clean and deliver the old straining elements to Owner. Fit the Owner's strainers with a line size blowoff valve.

12. Install bypass piping or hoses at the supply and return piping connections at heat exchangers, chillers, cooling towers, pumps, and cooling coils, etc., to prevent debris from being caught or causing damage to equipment which will be connected to the piping system.
13. Circulate a chemical cleaner in chilled and heating water piping systems to remove mill scale, grease, oil, and silt. Cleaner to be selected by chemical treatment vendor on project. Circulate for 48 hours, flush system and replace with clean water. Dispose of chemical solution in accordance with local codes. The chilled and heating water system should then be treated with chemicals and inhibitors to be selected by chemical treatment vendor on project. When the chemical cleaning is complete, remove, clean, and reinstall all permanent screens. Notify Owner so that the reinstallation of clean strainer screens may be witnessed.
14. Do not install underground piping when bedding is wet or frozen.

D. Above Ground Piping Installation:

1. Install per manufacturer's written instructions and requirements.
2. Install heating water, glycol, condenser water, piping to ASME B31.9 requirements. Install chilled water piping to ASME B31.5 requirements.
3. PVC Pipe: Make solvent-welded joints in accordance with ASTM D 2855.
4. Route piping in orderly manner, parallel to building structure, and maintain gradient.
5. Install piping to conserve building space and to avoid interference with use of space.
6. Install groups of pipes parallel to each other, spaced to permit applying insulation and servicing of valves.
7. Sleeve pipe passing through partitions, walls and floors allowing adequate space for pipe insulation.
8. Slope piping at 0.2 percent upward in direction of flow and arrange to drain at low points.
9. Install piping to allow for expansion and contraction without stressing pipe, joints, or connected equipment.
10. Install drains, consisting of a tee fitting, NPS 3/4 ball valve, and short NPS 3/4 threaded nipple with cap, at low points in piping system mains and elsewhere as required for system drainage.
11. Drawings are diagrammatic and do not necessarily show top connections in all cases. Install branch connections to mains using tee fittings in main, with takeoff coming out of the top unless trade coordination conditions preclude it.
12. Anchor piping for proper direction of expansion and contraction.
13. Inserts:
 - a. Provide inserts for placement in concrete formwork.
 - b. Provide inserts for suspending hangers from reinforced concrete slabs and sides of reinforced concrete beams.
 - c. Provide hooked rod to concrete reinforcement section for inserts carrying pipe over 4-inches.
 - d. Where concrete slabs form finished ceiling, locate inserts flush with slab surface.
 - e. Where inserts are omitted, drill through concrete slab from below and provide through-bolt with recessed square steel plate and nut flush with top of slab.
14. Pipe Hangers and Supports:
 - a. Install in accordance with Division 23, HVAC, Hangers and Supports.
 - b. Install hangers to provide minimum 1/2-inch space between finished covering and adjacent work.
 - c. Place hangers within 12-inches of each horizontal elbow.

- d. Use hangers with 1-1/2-inch minimum vertical adjustment. Design hangers for pipe movement without disengagement of supported pipe.
 - e. Support vertical piping at every floor. Support riser piping independently of connected horizontal piping.
 - f. Where several pipes can be installed in parallel and at same elevation, provide multiple or trapeze hangers.
 - g. Prepare unfinished pipe, fittings, supports, and accessories, ready for finish painting.
 - h. Provide copper plated hangers and supports for copper piping.
 - i. Prime coat exposed steel hangers and supports. Hangers and supports located in crawl spaces, pipe shafts, and suspended ceiling spaces are not considered exposed.
15. Provide clearance in hangers and from structure and other equipment for installation of insulation and access to valves and fittings.
 16. Provide access where valves and fittings are not exposed.
 17. Use eccentric reducers to maintain top of pipe level.
 18. Where pipe support members are welded to structural building framing, scrape, brush clean, and apply one coat of zinc rich primer to welds.
 19. Prepare unfinished pipe, fittings, supports, and accessories, ready for finish painting.
- E. Field Quality Control:
1. Leave joints, including welds, uninsulated and exposed for examination during test.
 2. Provide temporary restraints for expansion joints that cannot sustain reactions due to test pressure. If temporary restraints are impractical, isolate expansion joints from testing.
 3. Flush system with clean water. Clean strainers.
 4. Isolate equipment from piping. If a valve is used to isolate equipment, provide closure capable of sealing against test pressure without damage to valve. Install blinds in flanged joints to isolate equipment.
 5. Install safety valve, set at a pressure no more than one-third higher than test pressure, to protect against damage by expanding liquid or other source of overpressure during test.
 6. Perform the following tests on hydronic piping:
 - a. Use ambient temperature water as a testing medium unless there is risk of damage due to freezing. Another liquid that is safe for workers and compatible with piping may be used.
 - b. While filling system, use vents installed at high points of system to release trapped air. Use drains installed at low points for complete draining of liquid.
 - c. Check expansion tanks to determine that they are not air bound and that system is full of water.
 - d. Subject piping system to hydrostatic test pressure that is not less than 1.5 times the design pressure. Test pressure not-to-exceed maximum pressure for any vessel, pump, valve, or other component in system under test. Verify that stress due to pressure at bottom of vertical runs does not exceed either 90 percent of specified minimum yield strength or 1.7 times "SE" value in Appendix A of ASME B31.9, "Building Services Piping."
 - e. After hydrostatic test pressure has been applied for at least four hours, examine piping, joints and connections for leakage. Eliminate leaks by tightening, repairing, or replacing components, and repeat hydrostatic test until there are no leaks.
 - f. Prepare written report of testing.
- F. Flushing and Cleaning of Piping Systems:

1. Clean piping systems thoroughly. Purge pipe of construction debris and contamination before placing the piping systems in service. Provide temporary connections for cleaning, purging, and circulating fluids through the piping system.
2. Use temporary strainers and temporary pumps that can create fluid velocities up to 10 feet per second to flush and clean the piping systems. Do not use Owner's permanent strainers to trap debris during pipe flushing operations. Fit the temporary construction strainers with a line size blowoff valve.
3. When constructing minor piping modifications or additions, verify with Owner if the Owner's pumps and strainers can be used for flushing and chemical cleaning operations. When the flushing and cleaning operations are complete, ensure the strainer baskets and screens installed in the piping systems permanent strainers are replaced with clean elements. Keep temporary strainers in service until the equipment has been tested, then replace straining element with a new strainer and clean and deliver the old straining elements to Owner. Fit the Owner's strainers with a line size blowoff valve.
4. Install bypass piping or hoses at the supply and return piping connections at heat exchangers, chillers, cooling towers, pumps, and cooling coils, etc., to prevent debris from being caught or causing damage to equipment which will be connected to the piping system.
5. Circulate a chemical cleaner in chilled and heating water piping systems to remove mill scale, grease, oil, and silt. Cleaner to be selected by chemical treatment vendor on project. Circulate for 48 hours, flush system and replace with clean water. Dispose of chemical solution in accordance with local codes. The chilled and heating water system should then be treated with chemicals and inhibitors to be selected by chemical treatment vendor on project. When the chemical cleaning is complete, remove, clean, and reinstall all permanent screens. Notify Owner so that the reinstallation of clean strainer screens may be witnessed.

G. Pipe Painting Requirements:

1. Paint all ferrous metal pipe including flanges. Do not paint flange bolts, washers and nuts. At flexible coupling the only the flanges are to be painted. All rubber portions are to remain unpainted.
2. Paint exterior uninsulated steel piping with exterior latex, semi-gloss (AE), Master Painters Institute MPI 11, suitable for metallic surfaces B, Haze Gray color.
3. Use ready-mixed (including colors) paint. Prime paint with pigment and vehicle, compatible with substrate and finish coats specified. Volatile Organic Compounds (VOC) content of paint materials shall not exceed 50g/l for exterior latex paints and primers. Lead-based paint is not permitted.
4. Do not apply coating when air or substrate conditions are:
 - a. Less than 5 degrees F above dew point.
 - b. Below 50 degrees F or over 95 degrees F, unless specifically pre-approved by the product manufacturer.
5. Do no exterior painting when it is windy and dusty. Do not paint in direct sunlight or on surfaces that the sun will soon warm.
6. Apply only on clean, dry and frost-free surface. Remove all materials the will affect the ability of the paint to adhere to the pipe including painted pipe identification labels.
7. Remove oil, grease, soil, drawing and cutting compounds, flux and other detrimental foreign. Remove loose mill scale, rust, and paint, by hand or power tool cleaning. All surfaces are to be dry at the time paint is applied.

8. Apply paint in two coats; prime, and finish. Apply each coat evenly and cover substrate completely. Allow not less than 48 hours between application of succeeding coats, except as allowed by manufacturer's printed instructions.
9. Finish surfaces to show solid even color, free from runs, lumps, brushmarks, laps, holidays, or other defects. Apply by brush, roller or spray.

END OF SECTION

SECTION 23 2113.33 - GROUND-LOOP HEAT-PUMP PIPING

PART 1 - GENERAL

1.1 SUMMARY

- A. Work Included:
 - 1. Heat Exchanger
 - 2. Materials
 - 3. Thermally Enhanced Bentonite Grout
 - 4. Horizontal Backfill Material
 - 5. Polyethylene Valve Vault

1.2 RELATED SECTIONS

- A. Contents of Division 23, HVAC and Division 01, General Requirements apply to this Section.
- B. In addition, reference the following:
 - 1. Division 31, Earthwork
 - 2. Section 23 21 13 - HVAC Piping
 - 3. Section 23 23 00 - Refrigerant Piping
 - 4. Section 22 30 00 - Plumbing Equipment

1.3 REFERENCES AND STANDARDS

- A. References and Standards as required by Section 23 00 00, HVAC Basic Requirements and Division 01, General Requirements.
- B. In addition, meet the current edition of the following:
 - 1. 49 CFR 192.285 - Plastic Pipe: Qualifying Persons to Make Joints; current edition.
 - 2. APHA (EWWW) - Standard Methods for the Examination of Water and Wastewater; American Public Health Association.
 - 3. ASHRAE (HVACA) - ASHRAE Handbook - HVAC Applications, Chapter 32, Geothermal Energy; American Society of Heating, Refrigerating and Air-Conditioning Engineers, Inc.
 - 4. ASTM B 88 - Standard Specification for Seamless Copper Water Tube.
 - 5. ASTM B 88M - Standard Specification for Seamless Copper Water Tube (Metric).
 - 6. ASTM B 280 - Standard Specification for Seamless Copper Tube for Air Conditioning and Refrigeration Field Service.
 - 7. ASTM D 92 - Standard Test Method for Flash and Fire Points by Cleveland Open Cup Tester.
 - 8. ASTM D 1177 - Standard Test Method for Freezing Point of Aqueous Engine Coolants.
 - 9. ASTM D 2447 - Standard Specification for Polyethylene (PE) Plastic Pipe, Schedules 40 and 80, Based on Outside Diameter.
 - 10. ASTM D 2683 - Standard Specification for Socket-Type Polyethylene Fittings for Outside Diameter-Controlled Polyethylene Pipe and Tubing.
 - 11. ASTM D 2837 - Standard Test Method for Obtaining Hydrostatic Design Basis for Thermoplastic Pipe Materials or Pressure Design Basis for Thermoplastic Pipe Products.

12. ASTM D 3035 - Standard Specification for Polyethylene (PE) Plastic Pipe (DR-PR) Based on Controlled Outside Diameter.
13. ASTM D 3261 - Standard Specification for Butt Heat Fusion Polyethylene (PE) Plastic Fittings for Polyethylene (PE) Plastic Pipe and Tubing.
14. ASTM D 3350 - Standard Specification for Polyethylene Plastics Pipe and Fittings Material.
15. ASTM F 714 - Standard Specification for Polyethylene (PE) Plastic Pipe (SDR-PR) Based on Outside Diameter.
16. ASTM F 1055 - Standard Specification for Electrofusion Type Polyethylene Fittings for Outside Diameter Controlled Polyethylene Pipe and Tubing.
17. ASTM F 1105 - Standard Test Method for Preparing Aircraft Cleaning Compounds, Liquid-Type, Temperature-Sensitive, or Solvent-Based, for Storage Stability Testing.
18. EPA 712-C-02-190 - Health Effects Test Guidelines OPPTS 870.1100 Acute Oral Toxicity; United States Environmental Protection Agency.
19. IGSHA (GROUT) - Grouting Procedures for GHP Systems; International Ground Source Heat Pump Association.
20. IGSHA (GVERT) - Grouting for Vertical GHP Systems; International Ground Source Heat Pump Association.
21. IGSHA (INSTALL) - Closed-Loop/Ground-Source Heat Pump Systems: Installation Guide; International Ground Source Heat Pump Association.
22. IGSHA (SLINKY) - Closed-Loop Geothermal Systems Slinky Installation Guide; International Ground Source Heat Pump Association.
23. NFPA 704 - Standard System for the Identification of the Hazards of Materials for Emergency Response; National Fire Protection Association.
24. PPI TR4 - PPI Listing of Hydrostatic Design Basis (HDB), Strength Design Basis, Pressure Design Basis (PDB) and Minimum Required Strength (MRS) Ratings for Thermoplastic Piping Materials or Pipe; Plastics Pipe Institute.
25. USGS (FMWQ) - National Field Manual for the Collection of Water-Quality Data; United States Geological Survey; current edition.

1.4 SUBMITTALS

- A. Submittals as required by Section 23 00 00, HVAC Basic Requirements and Division 01, General Requirements.
- B. In addition, provide:
 1. Product Data, Polyethylene Piping: Provide manufacturer's data for piping and pipe fittings, showing compliance with specified requirements.
 - a. Provide manufacturer's recommendations for fusion jointing.
 - b. Include certification of long term hydrostatic basis, or test reports.
 2. Product Data, Heat Exchange Fluid: Provide data showing compliance with specified requirements.
 - a. Provide manufacturer's Material Data Safety Sheets.
 - b. Provide results of biodegradability studies conducted in accordance with APHA (EWWW):
 - 1) Statement of ecological behavior.
 - 2) Total oxygen demand, in pounds of oxygen per pound of fluid.
 - 3) Percent of fluid degraded in five days.
 3. Product Data, Grout and Slurry: Provide information on thermal conductivity of proposed materials.

4. Shop Drawings: Show complete piping layout, water table, water level, depths of excavation, final depths of piping, backfill placement, point of entrance to building, point of connection to equipment, test point locations, and fittings used for joints and connections.
5. Design Calculations: Submit design calculations along with drawings.
6. Pipe Samples: Provide one 2-inch length of pipe in selected size.
7. Soil and Rock Samples: Provide one sample from the area of proposed installation.
8. Georexchange Sample Test Bore Reports:
 - a. Thermal Response Testing: Not less than 80 hours; indicate dates and times on Test Report.
 - b. Test Results:
 - 1) Tested formation thermal conductivity: BTU/(hr. x ft. x degrees F).
 - 2) Tested undisturbed ground temperature at 100 feet: Degrees F.
 - 3) Tested borehole thermal resistance: hr. x ft. x degrees F/BTU.
 - 4) Calculated formation thermal diffusivity: sq.ft./day.
 - c. Drilling Results:
 - 1) Contractor Name:
 - 2) License Number:
 - 3) Bore Diameter:
 - 4) Drilling Technique Used:
 - 5) Static Water Level:
 - 6) Productivity Time:
 - 7) Adverse Drilling Conditions:
 - 8) Sample Log of Drilling:

Formation Log	Color	Hardness of Formation	Depth from (ft.)	Depth to (ft.)
			0	20
			21	40
			41	100
			101	200
			201	400

- d. Vertical Heat Exchanger Installation:
 - 1) Active depth of installation: ft.
 - 2) Pipe Type: (See specifications).
 - 3) Field pressure testing: Pass/Fail.
 - 4) Pipe diameter and SDR: inches/SDR.
 - 5) Grout Type: (See specifications.)
 - 6) Grout volume required to fill grade:
 - 7) Installation record filed with:
 - 8) Record identification number:
- e. Testing and Data Collection Procedures: Follow International Ground Source Heat Pump Association (IGSHPA) Standards (latest edition). Identify complete testing procedures in report.
- f. Soil Temperature Measurement: IGSHPA Standards (latest edition).
- g. Provide graphs indicating:
 - 1) Control quality of testing: Time (hours) versus Temperature (degrees F).

- 2) Temperature vs. Linear Time: Logarithmic Time (LN(hr)) vs. Temperature (degrees F).
 - 3) Borehole Saturation Time: Time (hrs) vs. Borehole Thermal Resistance.
 - 4) Temperature vs. Time: Test Duration vs. Fluid Temperature (degrees F) over 80 hours.
 - 5) Fluid Delta T vs. Time: Test Duration vs. Delta T (degrees F) over 80 hours.
 - h. Provide graph depicting heat rate and consistency of power applied to each test. Provide heat development to comply with ASHRAE/IGSHPA recommendations.
 - i. Thermal Conductivity Calculation: Heat transfer model such as a line source method analysis. IGSHPA/ASHRAE calculation methods to be used.
 - j. Thermal Diffusivity Calculations: Provide results that relate to each formation.
 - k. Borehole Thermal Resistance: Use formula provided by Gehlin (2002).
 - l. For horizontal directional drilling samples, provide data for soil formations at: 15 feet, 30 feet, and 45 feet below grade.
9. Record Documents: Record actual locations of underground piping installed relative to Owner's permanent structure on same property.
 10. Grout Sampling: Loop Field Contractor to take at least three separate grout samples from the grout mixing/holding tank and provide results as submittals. Samples to be taken from the actual grouting process. Samples to be taken after ten percent of bores, 50 percent of the bores and 80 percent of the bores are completed. Loop Field Contractor to submit the samples to an independent testing agency to determine permeability and thermal conductivity. Loop Field Contractor to indicate to the Engineer what laboratory will be used to perform the tests. Grout composition to be changed as needed to bring non-compliant grout into specification compliance. The Owner reserves the right to take independent grout samples and have them tested during the process to confirm what the contractor testing finds.
 11. Geothermal Bore Log Submittal: Loop Field Contractor to keep daily bore logs that document the history of each bore as it is installed and provide as a submittal. The log to include but is not limited to the following information.
 - a. Number bore, and depth of installation.
 - b. Date and time bore was finished.
 - c. Grouting information for each bore.
 - d. Sign off on bore log each day by the installing contractor's representative and the Owner's Authorized Representative and the Mechanical Contractor site representative.
 - e. Loop Field Contractor to provide a copy of the log to the Engineer, Owner, and the Mechanical Contractor.
 12. Operation and Maintenance Data: Provide procedures for pressurizing, charging, and isolation for equipment replacement.

1.5 QUALITY ASSURANCE

- A. Quality assurance as required by Section 23 00 00, HVAC Basic Requirements and Division 01, General Requirement.
- B. In addition, meet the following:
 1. Designer Qualifications: Licensed Professional Engineer, regularly engaged in the design of systems of the type and capacity specified in this Section, with not less than five years of documented experience, and accredited by IGSHPA.

2. Installer Qualifications: Company specializing in performing the work of this Section with minimum five years of documented experience and accredited by IGSHPA. Supply with the bid information on past jobs of similar scope. The following information must be supplied:
 - a. Name of Project/Customer
 - b. Location of Project
 - c. Customer Contact Name (Reference) with Phone Numbers
 - d. Project Designer/Engineer
 - e. Date of Installation
 - f. Number of Wells
 - g. Depth of Wells
 - h. Grout Used
3. The Engineer will be the sole judge whether a specific contractor is qualified based on the qualifications submitted.
4. Heat Fusion Technician Certification: IGSHPA training and certification, certified within three years from the date of project commencement.

1.6 WARRANTY

- A. Warranty of materials and workmanship as required by Section 23 00 00, HVAC Basic Requirements and Division 01, General Requirements.
- B. In addition, provide:
 1. The pipe manufacturer to provide a minimum warranty of twenty-five years. The warranty to be transferable.

1.7 DELIVERY, STORAGE, AND HANDLING

- A. Deliver piping and fittings to project site in shipping containers with labeling in place.
 1. Comply with local and state regulations.
 2. Verify that labels on piping indicate manufacturer's name, pipe or tube size, and PE cell classification.
 3. Verify that piping complies with specifications and is undamaged.
- B. Deliver chemicals for heat exchange fluid to project site in unopened shipping containers with labeling in place; comply with local and state regulations.
- C. Protect from weather, humidity and temperature variations, dirt and dust, and other environmental contaminants.
- D. Store piping capped or plugged until time of installation.

1.8 PRICE AND PAYMENT PROCEDURES

- A. See Division 01, General Requirements.
- B. Piping:
 1. Basis of Measurement: By the linear foot (meter).
 2. Basis of Payment: Includes excavating.

1.9 ADMINISTRATIVE REQUIREMENTS

- A. Preinstallation Meeting: Convene one week before starting work of this Section. Require attendance by installers involved with site work and HVAC work.

1.10 SITE RESTORATION AND CLEANUP

- A. Keep the premises clean and orderly at all times during the Work. Upon completion of the Work, repair damage caused by equipment, remove equipment, tools, materials, containers and debris and leave the project and staging area free of rubbish, protective materials or excess materials of any kind.
- B. Wastes generated to be properly contained and disposed of in accordance with local State and Federal regulations.

PART 2 - PRODUCTS

2.1 MANUFACTURERS

- A. Materials:
 - 1. GEM Products, Ground Energy Manufacturing Products, Phone: 515-758-3920
 - 2. HDPE Fabricator
 - 3. Performance Pipe
 - 4. Centennial Plastics
 - 5. Or approved equivalent.
- B. Thermally Enhanced Bentonite Grout:
 - 1. GedPro Inc.
 - 2. Or approved equivalent.
- C. Horizontal Backfill Material:
 - 1. Reference "Horizontal Backfill Material" article below.
- D. Polyethylene Valve Vault:
 - 1. Geothermal Sales Company Inc., Horse Cave, Kentucky, Phone: 270-786-3010
 - 2. Or approved equivalent.

2.2 HEAT EXCHANGER

- A. Contractor is responsible for design and execution of the closed-system ground-coupled heat exchanger, to the requirements of and within the limitations of the Contract Documents.
 - 1. Design in accordance with methodology in IGSHPA Closed-Loop/Ground-Source Heat Pump Systems: Installation Guide.
 - 2. Design heat exchanger to comply with heat pump manufacturer's specifications and operating requirements.
 - 3. Circulator pumps, utilization equipment, gauges, and sensors are specified elsewhere and are the responsibility of this designer.
 - 4. If the Drawings do not indicate the interface between the heat exchanger and the equipment, provide three valves and a by-pass to isolate the heat exchanger from the equipment plus at least one charging valve.
 - 5. Provide an IGSHPA registered system, with certificate and label.

- B. Heat Exchanger Performance:
1. Heat Transfer Capacity for Heating: 53,200 Btuh.
 2. Heat Transfer Capacity for Cooling: 77,7000 Btuh.
 3. Maximum Working Pressure: 100 PSIG.
 4. Design Operating Pressure: 45 PSIG.
 5. Minimum Winter Temperature of Fluid (Winter Inlet Temperature): 32 degrees F.
 6. Maximum Summer Temperature of Fluid (Summer Inlet Temperature): 77 degrees F.

2.3 MATERIALS

- A. Pipe: High density polyethylene pipe, Type PE3408, PE3608, or PE4710, with minimum ASTM D 3350 cell classification of PE345364C.
1. Markings: Sufficient information, including numerical markings every two (2)-feet, to be permanently marked on the length of the pipe. This information is defined by the appropriate ASTM pipe standard. Fittings to be similarly marked. Marked information to include:
 - a. Manufacturer's name
 - b. Nominal size
 - c. Pressure rating
 - d. Relevant ASTM standards
 - e. Cell classification number
 - f. Date of manufacture
 2. Pipe Used in Vertical Bore Applications: Comply with ASTM D 3035 with minimum working pressure rating of 160 PSI (DR-11).
 3. Piping used for the u-bend heat exchanger (pipe located in the borehole) will have factory hot-stamped lengths impressed on the side of the piping indicating the length of the heat exchanger to that point. The length to read "0" (zero) on one end and the actual heat exchanger total length on the other end.
 4. The u-bend assembly for the vertical bore hole to be factory- manufactured or shop-fabricated in a controlled environment and randomly tested at 100 PSI under quality control conditions and be constructed of the same material designation prior to delivery to the Site. The vertical heat exchanger to have a factory-fused u-bend with pipe lengths long enough to reach grade from the bottom of the bore so no field fusion welds are required below the header pit.
 5. Other Pipe of 3-inches Diameter and Larger: Comply with ASTM D 3035 or ASTM F 714, with minimum working pressure rating of 100 PSI, or ASTM D 2447 Schedule 40.
 6. Other Pipe 1-1/4-inches But Less Than 3-inches In Diameter (Nominal): Comply with ASTM D 3035 with minimum working pressure rating of 110 PSI, or ASTM D 2447 Schedule 40.
 7. Other Pipe Less Than 1-1/4-inches in Diameter (Nominal): Comply with ASTM D 3035 with minimum working pressure rating of 160 PSI.
 8. Infield Extended Header: Infield extended headers to be manufactured by a geothermal HDPE fabrication company. Approved geothermal HDPE fabricator for headers is Ground Energy Manufacturing Products (GEM Products) or Engineer approved equivalent. The Loop Field Contractor may field fabricate the extended headers from HDPE piping as long as actual fabrication personnel are certified in HDPE fusion welding as indicated by certifications included in submittal. Ground Energy Manufacturing Products; phone 515-758-3920.
 9. Long Term Hydrostatic Design Basis: 1600 PSI at 73 degrees F, when tested in accordance with ASTM D 2837; appropriate listing in current edition of PPI TR-4 will

- constitute evidence of compliance with this requirement; otherwise, submit independent test results.
10. Joints and Fittings: Polyethylene of same type as pipe, of sizes and types suitable for the pipe being used; use only heat fusion or stab-type mechanical fittings that are quality controlled to provide a leak-free union between piping ends that is stronger than the piping itself. Do not use other barbed fittings or hose clamps.
 - a. Electrofusion Type Fittings: Comply with ASTM F 1055.
 - b. Butt Fusion Fittings: Comply with ASTM D 3261.
 - c. Socket Type Fittings: Comply with ASTM D 2683.
 - d. Where threaded fittings must be used for connection to equipment or dissimilar piping, use fittings and thread sealant compatible and effective with antifreeze used.
- B. Pipe, Fittings, and Jointing: Copper, as specified in Section 23 23 00, coated with polyethylene for corrosion protection.
1. Pipe Over 7/8-inches Outside Diameter: Copper tubing, refrigeration grade, ASTM B 280, H58 hard drawn.
 2. Pipe of 7/8-inches Outside Diameter or Less: Copper tubing, refrigeration grade, ASTM B 88 (ASTM B 88M) Type K annealed.
- C. Heat Exchange Fluid: Water and antifreeze solution, 20 percent propylene glycol by weight.
- D. Antifreeze:
1. Antifreeze solutions to meet local and state requirements and be USDA approved food grade and be acceptable by component manufacturers.
 2. Geothermal heat pump systems to be labeled and identified at the loop charging valves:
 - a. Antifreeze type and concentration
 - b. Service date
 - c. Company name
 - d. Company phone number and responsible party or person
 3. Form: These standards are intended to cover corrosion-inhibited, biodegradable, food grade, propylene glycol liquid antifreeze materials as received at the job site.
 4. Application: For used in closed-loop geothermal heat pump systems for the transfer of energy to provide heating and cooling in residential and commercial applications.
 5. Safety: While these standards attempt to define antifreeze materials characteristics that are safe to environment and personnel, it is the sole responsibility of the user to become familiar with the safe and proper used of materials provided under these standards and to take necessary precautionary measures to ensure the health and safety of personnel involved.
 6. Technical requirements:
 - a. Material: The composition of the fluid to be at the option of the manufacturer. The fluid may contain corrosion inhibitors, etc., as required to produce a product meeting the specified requirements.
 - 1) Biodegradability: Provide fluid not be less than 90 percent biodegradable. Results of the biodegradable studies conducted in accordance with “Standard Methods of the Examination of Water and Waste Water: for biodegradability and bioassay to, when requested by the Owner, be provided by the fluid manufacturer to the Owner and contain not less than the following information:
 - (a) A statement of ecological behavior of the fluid.

- (b) The total oxygen demand (TOD) of the fluid, expressed in pounds of oxygen per pound of fluid.
 - (c) The percent of the fluid demonstrate low corrosion to internal surface of materials found in geothermal heat pump systems.
 - 2) Corrosion: Fluid to demonstrate low corrosion to internal surface of materials found in geothermal heat pump systems.
 - 3) The propylene glycol water mixture to be 25 percent glycol/75 percent water nominally. The heat pump system has been designed on this ratio. The glycol water mixture to be premixed and contain de-mineralized or de-ionized water.
 - b. Properties: Fluid to conform to the following requirements, and tests performed in accordance with specified test methods on the fluid:
 - 1) Flash point: Not lower than 194 degrees F. determined in accordance with ASTM D92.
 - 2) Biological oxygen demand; Five days BOD at 50 degrees F. not-to-exceed 0.2 gram oxygen per gram nor be less than 0.1 gram oxygen per gram.
 - 3) Freezing point: Not-to-exceed +18 degrees F. determined in accordance with ASTM D1177.
 - 4) Toxicity: Not less than LD 50 (oral-rats) of 5 grams per kilogram. The NFPA hazardous material rating for health not more than 1 (slight).
 - 5) Storage stability: The fluid, tested in accordance with ASTM F1105, to show neither separation from exposure to heat or cold, nor show increase in turbidity.
 - c. Quality: The fluid, as received by the Owner, to be homogenous, uniform in color and free from skins, lumps, and foreign materials detrimental to usage of the fluid.
 - 7. Packaging and identification:
 - a. Fluid delivered in bulk. Make up fluid packaged in container and size agreed upon by the Owner.
 - b. Containers of fluid prepared for shipment in accordance with commercial practice and in compliance with applicable rules and regulations pertaining to the handling, packaging and transportation of the fluid to ensure carrier acceptance and safe delivery.
 - c. An up-to-date Material Safety Data Sheet to be supplied to the Owner upon request and concurrent with each delivery.
 - 8. The propylene water mixture to be provided by Interstate Chemical, Barsol, Houghton, Dow, or Engineer approved equal.
- E. Good quality threaded fittings and a thread sealant specified for use with the antifreeze selected to be used. Some antifreeze solutions require more fittings torque than others to prevent leaks and corrosion of external surfaces when the antifreeze is exposed to oxygen.
- F. Pipe Insulation: Closed cell, water resistant plastic foam with thermal resistance of at least R2.
- G. Detectable Underground Tape: Warning tape to be foil backed, 2" wide or greater with a continuous message printed every 36" or less reading: "CAUTION GEOTHERMAL PIPELINE BURIED BELOW". Tape to be highly resistant to alkalis, acids and other destructive agents found in the ground. Provide warning tape to indicate the location of the horizontal and vertical portions of the entire geothermal loop field. Provide heat exchanger loop piping location using GPS technology.

H. Backfill for Vertical Boreholes: Thermally enhanced Bentonite grout.

2.4 THERMALLY ENHANCED BENTONITE GROUT

A. General:

1. Summary: Thermally-enhanced bentonite grout to be used to seal and backfill each vertical u-bend well bore of the closed-loop ground heat exchanger to ensure proper thermal contact with the earth and to ensure the environmental integrity of each vertical bore column. Grouting material to remain in a plastic state (moldable) throughout the life of the system and not generate heat during the hydration process. No other backfill material accepted.
2. Submittals: Manufacturer's published data sheets including thermal conductivity, permeability, percent solids, grout weight, linear shrinkage potential, maximum particle size and unit yield along with verification of the required listing(s).
3. Quality Assurance: Grouting compound (bentonite-based and silica sand additive) to be certified and listed by NSF (National Sanitation Foundation International) to ANSI/NSF Standard 60, "Drinking Water Treatment Chemicals - Health Effects".

B. Product:

1. Manufacturer/Product: Grouting material to be one of Black Hills Bentonite's Thermal Grout products as supplied by GeoPro, Inc. or pre-approved equivalent. The thermal enhancement compound (high-grade silica sand) to be specified and supplied by the developer and supplier of the bentonite base material. Approved supplier is GeoPro, Inc. or pre-approved equivalent.
2. Thermal Conductivity: The thermal conductivity of the grouting compound must be 1.00 Btu/hr-ft-°F or greater as determined when tested in accordance to ASTM D-5334, "Standard Test Method for Determination of Thermal Conductivity of Soils and Soft Rock by Thermal Needle Probe Procedure". The reported thermal conductivity value to be verified by an independent company which has a minimum of 5 years experience in measuring thermal conductivity using this method. A copy of the verification report to be supplied upon request from the engineer.
3. Permeability: The grout mixture to have a maximum permeability rate of less than 8.0×10^{-8} cm/s as determined by using ASTM D-5084, "Measurement of Hydraulic Conductivity of Saturated Porous Materials using a Flexible Wall Permeameter, Method C - test with increasing tailwater level". The reported permeability to be verified by an independent lab with a copy of the report being supplied upon request from the engineer. Credentials of the independent laboratory to also be supplied upon request from the design engineer.
4. Total Solids and Enhancement Compound Percentage: The thermally enhanced bentonite grout used to have a minimum manufacturer's recommended mixture of 65.1 percent solids. The thermal enhancement compound (high-grade silica compound) to constitute a minimum of 54.2 percent by weight of the aqueous slurry.
5. Installed Material Set: The installed grouting material to be fully set into a putty consistency within a minimum of 4 hours after being pressure pumped in the vertical bore annulus.

C. Packaging: Provide Bentonite and thermal enhancement compound pre-manufactured and pre-packaged prior to delivery to the job site.

2.5 HORIZONTAL BACKFILL MATERIAL

- A. Earth Fill: Approved type of soil classified, in accordance with ASTM D-2487, as GW, GP, GM, SW, SP, SM, SC, ML or CL and free of foreign substances, obtained from excavation on this project, or other approved source, and having a plasticity index between 7.5 and 17.

2.6 POLYETHYLENE VALVE VAULT

- A. Polyethylene valve vault constructed from 1" high-density polyethylene sheet stock material and manufactured from the same material as the ground heat exchanger pipe and fittings. Pipe penetrations through the vault wall to be heat welded both on the inside and outside of the vault. Vault constructed as shown on the Drawings.

PART 3 - EXECUTION

3.1 GENERAL INSTALLATION REQUIREMENTS

- A. Examination and Preparation:
 - 1. Verify location of existing structures and utilities prior to excavation.
 - 2. Verify soil composition and rock depth, if any, before beginning excavation.
 - 3. Protect adjacent structures from the effects of excavation.
 - 4. Verify that layout dimensions are correct and that available land is sufficient for design.
 - 5. Notify Architect of unsatisfactory conditions.
 - 6. Do not proceed with installation until unsatisfactory conditions have been corrected.
 - 7. Coordinate work with site grading, site backfilling, and foundation construction.
 - 8. Loop Field Contractor to obtain permission from adjacent property owners if needed, to setup boring and grouting equipment. Loop Field Contractor responsible for any repairs and cleanup of these adjacent properties required as a consequence of installing the loop field.

- B. Excavation:
 - 1. Excavate in accordance with requirements of authorities having jurisdiction.
 - 2. Remove rock as specified in Division 31.
 - 3. Vertical Boreholes: Drill to depths required:
 - a. Drill bore hole in accordance with local, State or Federal requirements.
 - b. Follow requirements for bore hole drilling as prescribed by the AHJ. Receive permission in writing from the AHJ prior to proceeding and be responsible for maintaining any drilling logs that may be required. Bore hole installation cannot proceed until written proof of permission given by the AHJ has been provided.
 - c. Minimize over-drilling; fill over-drilled areas with backfill or excavated materials.
 - 4. Trenches: Excavate trenches for piping to lines and grades shown on drawings.
 - a. Minimize over-excavation; fill over-excavated areas with backfill or excavated materials.
 - b. Excavate to accommodate grade changes.
 - c. Excavate using the procedures specified in Division 31, Trenching for Site Utilities.
 - d. Maintain trenches free of debris, material, and obstructions that may damage pipe.
 - e. General: The horizontal ditches for the closed-loop ground heat exchanger header may be dug with a chain type trenching machine or a backhoe. Perform excavation of every description and of whatever substance encountered to the depths indicated

on drawings. During excavation, deposit material suitable for backfill in an orderly manner, a sufficient distance from the excavation banks to avoid overloading and to prevent slides or cave-ins. Grade as necessary to prevent surface water from flowing into trenches or other excavations, and remove water accumulating therein by pumping or other acceptable method. Unless otherwise indicated, excavation to be by open cut. Keep banks of trenches and excavation for structures as nearly vertical as practicable and where required, properly sheet and brace. Fill unauthorized excavation below levels indicated for pipe with sand.

- f. Trench Excavation: Excavate true to line to a depth to provide at least 5-feet above top of pipe and to provide clear space of not less than two (2)-inches on either side of pipe. Grade bottom of trenches accurately to provide uniform bearing and support for each Section of pipe on six (6)-inches of sand along its entire length.
 - g. Shoring Requirements: Perform shoring and sheeting that is required to protect the excavation and to safeguard employees in accordance with OSHA. Widen excavation to provide for space occupied by shoring and sheeting. Shoring to meet the requirements of applicable codes and regulations.
 - h. De-watering: Prevent surface water and subsurface or ground water from flowing into excavations and from flooding project Site and surrounding area. Do not allow water to accumulate in excavations. Remove water to prevent softening of foundation bottoms, undercutting footings and soil changes detrimental to stability of sub-grades and foundations. Provide and maintain pumps, well points, sumps, suction and discharge lines and other de-watering system components necessary to convey water away from excavations. Establish and maintain temporary drainage ditches and other diversions outside excavation limits to convey rain water and water removed from excavations to collecting or runoff areas. Do not use trench excavations as temporary ditches.
5. Install in compliance with local authorities having jurisdiction.
 6. Vertical Boreholes: Backfill after pipe installation in accordance with IGSHPA Grouting Procedures for GHP Systems.
 7. Trenches:
 - a. Provide minimum 60-inch cover over piping.
 - b. Backfill trenches after pipe has been installed and tested, using fill free of rocks and other debris.
 - c. Backfill: Prepare dimensioned drawings of the complete ground heat ex-changer piping system before backfilling. Trench backfilled by hand with a minimum of six (6)-inches of sand or fine soil material on each side and on top of the pipes. A horizontal underground-type metallic tracer warning tape placed twelve (12)-inches to eighteen (18)-inches below grade for the entire length of each header pipe. After piping is installed, tested, purged, inspected and approved, the remaining trench fill may be excavated material, free of boulders, large rocks, general debris or foreign matter. Care taken to avoid driving construction equipment over newly filled trenches unless bridging is provided to support load over trenches. Reference ASTM D-2321 for backfill procedures. Compact trenches to 90 percent dry density.
 - d. Backfill spiral pipe installation ("Slinky") in accordance with ISGHPA Slinky Installation Guide.
 8. Protect piping from displacement.
- C. Cleaning:
1. Leave adjacent paved areas broom clean.

2. Clear debris, including excess backfill and excavated dirt and rock, from heat exchanger area.
- D. Protection:
1. Protect area during excavation from excess runoff and erosion.
 2. Protect pipe protrusions from damage until connections to building systems are installed.
- E. Flushing and Purging:
1. Before backfilling the trenches, systems flushed and purged of air and flow tested to ensure portions of the closed-loop ground heat exchanger are properly flowing. A portable temporary purging unit to be utilized and consist of the following:
 - a. Purge pump - high volume and high head
 - b. Open reservoir
 - c. Filter assembly with by-pass
 - d. Flow meter
 - e. Pressure gauge
 - f. Connecting piping
 - g. Connecting hoses
 2. Using the purging unit described above, flush and purge each Section free of air, dirt and debris. A minimum velocity of 2-feet/second in each piping Section must be maintained for a minimum of fifteen (15) minutes to remove air. A change of more than one (1)-inch in the level of fluid in the purge pump tank during pressurization indicates air still trapped in the system. The flushing and purging operation conducted with the supply and return lines to the building capped and sealed at the flange termination connection within the building. Supply and return lines to the building filled as full as possible with water. Building mechanical contractor will be responsible for flushing and purging the interior portion of the system and a final purging of the entire system. Refill 100 percent of the piping installed with a mixture of water and food grade (USP grade) propylene glycol (20 percent by volume, polypropylene glycol or water.

3.2 HEAT EXCHANGER

- A. Solder/sweat connections utilize 45 percent silver solder AWS grade BAg-24 or equivalent brazing flux to be AWS specification FB3C AMS No. 3411 or equivalent.
- B. Use a wetted rag (soaked with water around base of connector. Do not overheat purge unit with nitrogen.
- C. Do not braze unit in horizontal, sitting flat position.
- D. Install per manufacturers written instructions and guidelines.

3.3 MATERIALS

- A. Polyethylene Piping Installation:
 1. Join piping and fittings using heat fusion or electrofusion; do not use solvents, adhesives, or mechanical fittings.
 2. Provide flanges or unions to connect heat exchanger piping to equipment or piping of different type; locate transitions between piping of different types inside the building or otherwise accessible (i.e. above grade).

3. Keep dirt, water, and debris out of pipe assemblies; cap or plug open ends until connected to adjacent piping.
4. Do not bend piping to shorter radius than recommended by pipe manufacturer; do not kink piping; use elbow or other fittings for sharp bends.
5. Partially backfill radius bends in narrow trenches by hand to ensure that piping is properly supported and to prevent kinking.
6. Installation (Header System):
 - a. Connections: Header pipes to be installed and fusion connected to the vertical u-bend assembly. The pipe and fittings must be joined using the socket, butt fusion or electrofusion process. No other method is acceptable. The quantity of fusion joints in the system to be kept to an absolute minimum. Reduction fittings to be used at pipe reductions to eliminate trapped air. Use reducing tees and pre-fabricated reducing type close headers. Consult pipe and/or fitting manufacturer for available fittings and headers.
 - b. Avoid sharp bends in piping runs. Minimum bend radius determined by the following:
 - 1) Minimum Radius = Pipe O.D. (actual) x 25
 - (a) Use only continuous lengths of pipe in bends. Install elbows fittings for required bends which are tighter radii than calculated above.
 - (b) Lateral piping supply and return lines or bundles separated to minimize thermal interference between the two. The number of points where the supply and return lines cross one another to be minimized.
 - c. Testing: After headers have been laid in the trenches and prior to backfill, the system to be pressurized with water and “back-up” air to a minimum of 100 PSI with no loss of pressure for a minimum of thirty (30) minutes. Each joint to be visually and physically inspected, using industry standards, for cold joints. Any joints failing the test to be completely removed from the system and a new joint or fitting installed with the test being repeated.
7. Installation (U-Bend)
 - a. Immediately after completion of the borehole and full removal of drilling equipment, the pre-tested, water filled u-bend assembly inserted into the borehole, u-bend first. A stiffener which does not present potential damage to the assembly may be use to straighten the leading Section of the assembly and to add counter weight for easier insertion.
 - b. Care to be taken so that the sealed pipe ends do not “drop” into the open borehole below graded surface.
 - c. When bore holes are drilled with a mud-rotary system, the u-bend to be staked and tied to prevent the assembly from “floating” out of the bore prior to the “setting” of the bentonite grout.
8. Test piping to be installed in boreholes after assembly but before installation in boreholes; re-cap tested assemblies before installation.
9. Testing (U-Bend): Perform hydrostatic test on piping; portions of assembled piping may be tested separately.
 - a. Prior to testing, isolate piping from connections to building systems.
 - b. Flush dirt and debris using potable water flowing at twice the normal operating flow rate for a minimum of four hours or until no dirt or debris is visible, whichever is longer.
 - c. Plug or cap piping.
 - d. Just prior to the u-bend assembly being placed in the borehole, it is ti be flow tested to ensure that there are no kinks, bends of pinches. The test to consist of

forcing clean water into one end of the assembly, and visually inspecting the discharge. If it is visible that an obstruction exists, the obstructed Section of pipe to be removed and replaced with an equal length Section which is free of obstructions and re-attached by heat fusion.

- e. Assembly to be pressurized with water and “back-up” with air as needed to achieve a minimum of 100 PSI. Assembly to have no significant loss in pressure for a minimum of 30 minutes. Allowances in pressure loss to be made for expansion per pipe manufacturer’s recommendations. At the conclusion of the test, the pipe ends to be sealed with a cap, plug or tape.
 - f. Circuits of closed-loop ground heat exchanger system to be water filled and pressure tested to 100 PSI for a minimum of one (1) hour prior to backfill of the trenched. Every weld to be visually and physically examined. If any leaks are detected at a fusion joint, they are to be cut out and replaced at which time that Section will be re-tested according to this Section.
 - g. Repeat test until there is no loss of pressure for the duration of the test.
10. Insulation: Insulate the following heat exchanger piping:
- a. Above ground piping: Insulate similar to chilled water.
 - b. Belowground but within 36-inches of ground surface. Insulate with a 1-inch closed-cell adhesive backed insulation.
 - c. Belowground running parallel with and within 5-feet of walls, structures, or water pipes.
 - d. Indoor piping that will be colder than ambient air temperature. Insulate similar to chilled water.

B. Copper Piping:

1. Install and test piping as specified in Section 23 23 00.
2. Join pipe and fittings by brazing. Do not bend pipe, use fittings. Provide flanges or unions to connect to equipment and building piping system.
3. Keep dirt, water, and debris out of assembled piping; plug or cap open ends immediately.
4. Provide for thermal movement of components in system.
5. Insulation: Insulate the following heat exchanger piping:
 - a. Immediately after completion of the borehole and full removal of drilling equipment, the pre-tested, water filled u-bend assembly to be inserted into the borehole, u-bend first. A stiffener which does not present potential damage to the assembly may be use to straighten the leading Section of the assembly and to add counter weight for easier insertion.
 - b. Care taken so that the sealed pipe ends do not “drop” into the open borehole below graded surface.
 - c. When bore holes are drilled with a mud-rotary system, the u-bend to be staked and tied to prevent the assembly from “floating” out of the bore prior to the “setting” of the bentonite grout.
6. Where piping passes through foundation walls, provide sleeves sealed with non-hardening, waterproof material.
7. Coordinate charging of piping with refrigerant with Section 23 23 00.

3.4 THERMALLY ENHANCED BENTONITE GROUT

- A. Mixing:** Thermally enhanced bentonite grouting material mixed according to manufacturer's written instructions.

- B. Installation: Grout material pressure pumped through a one (1)-inch, one and one-quarter (1-1/4)-inch or a one and one-half (1-1/2)-inch inside diameter tremie pipe and placed in the bore column from the bottom to the top. Grouting process to conform to the manufacturer's instructions and "Grouting for Vertical Geothermal Heat Pump Systems -- Engineering Design and Field Procedures Manual", as published by the International Ground Source Heat Pump Association (IGSHPA), Oklahoma State University (OSU), latest edition. Completed grouted surface placed at ground level to ensure complete fill of the bore column.
- C. Inspection: Since some settling may occur after initial placement of the grout material, the installer to monitor each borehole and continue adding grout as required for a period of no less than thirty (30) minutes and no longer than two (2) hours.
1. Grouting manufacturer to provide testing of site mixed grouting material in accordance to ASTM D-5334 to verify thermal conductivity. Manufacturer to provide a minimum of three, sample analysis for this project.
 2. At a minimum, sampling to be taken once at the beginning of the project, once at approximately one-third of completion, and finally at approximately two-thirds of completion. In the event that the analysis indicates a thermal conductivity value below the minimum specified value, corrective action to be taken to increase thermal conductivity value back to minimum specified requirement. A written report will be submitted defining corrective action taken.

3.5 HORIZONTAL BACKFILL MATERIAL

- A. For Horizontal Piping Systems:
1. Sharp bending of pipe around trench corners must be prevented by using a shovel to round corners, or by installing an appropriate elbow fitting. Manufacturer's procedures must be followed.
 2. Backfilling procedures will include prevention of any sharp-edged rocks from coming into contact with the pipe by removal of the rocks before backfilling. Use the IGSHPA Slinky backfilling procedures found in IGSHPA's Slinky Installation Guide to assure elimination of air pocket around the pipes.
 3. Return bends in narrow trenches must be partially backfilled by hand to properly support the pipes and prevent kinking.
 4. All buried GHP pipes in systems containing an antifreeze and passing parallel within 5-feet of any wall, structure, or water pipe shall be insulated with R2 minimum closed cell insulation.

3.6 POLYETHYLENE VALVE VAULT

- A. Polyethylene valve vault to be installed according to the diagram found on the Ground-Loop Heat Exchanger Site Plan drawings. Manufacturer's written installation procedures and instructions to be followed. A copy of these procedures to be supplied with other submittal data.

END OF SECTION

SECTION 23 2116 - HYDRONIC PIPING SPECIALTIES

PART 1 - GENERAL

1.1 SUMMARY

- A. Work Included:
 - 1. Diaphragm Type Expansion Tanks
 - 2. Air Vents
 - 3. Centrifugal Air Separator
 - 4. Pressure Reducing Valves
 - 5. Liquid Flow Switches
 - 6. Instrument Probe Fittings
 - 7. Strainers
 - 8. Relief Valves

1.2 RELATED SECTIONS

- A. Contents of Division 23, HVAC and Division 01, General Requirements apply to this Section.

1.3 REFERENCES AND STANDARDS

- A. References and Standards as required by Section 23 00 00, HVAC Basic Requirements and Division 01, General Requirements.
- B. In addition, meet the following:
 - 1. ASME (BPV VIII, 1) - Boiler and Pressure Vessel Code, Section VIII, Division 01 - Rules for Construction of Pressure Vessels; The American Society of Mechanical Engineers.

1.4 SUBMITTALS

- A. Submittals as required by Section 23 00 00, HVAC Basic Requirements and Division 01, General Requirements.
- B. In addition, provide:
 - 1. Product Data: Provide product data for manufactured products and assemblies required for this project. Include component sizes, rough-in requirements, service sizes, and finishes. Include product description, model and dimensions.
 - 2. Certificates: Inspection certificates for pressure vessels from Authority Having Jurisdiction (AHJ).
 - 3. Manufacturer's Installation Instructions: Indicate hanging and support methods, joining procedures.
 - 4. Project Record Documents: Record actual locations of flow controls.
 - a. Maintenance Data: Include installation instructions, assembly views, lubrication instructions, and replacement parts list.

1.5 QUALITY ASSURANCE

- A. Quality assurance as required by Section 23 00 00, HVAC Basic Requirements and Division 01, General Requirements.
- B. In addition, meet the following:
 - 1. Manufacturer Qualifications: Company specializing in manufacturing the type of products specified in this Section, with minimum three years of documented experience.

1.6 WARRANTY

- A. Warranty of materials and workmanship as required by Section 23 00 00, HVAC Basic Requirements and Division 01, General Requirements.

1.7 DELIVERY, STORAGE, AND HANDLING

- A. Accept valves on site in shipping containers with labeling in place. Inspect for damage.
- B. Provide temporary protective coating on cast iron and steel valves.
- C. Provide temporary end caps and closures on piping and fittings. Maintain in place until installation.
- D. Protect piping systems from entry of foreign materials by temporary covers, completing sections of the work, and isolating parts of completed system.

PART 2 - PRODUCTS

2.1 MANUFACTURERS

- A. Diaphragm Type Expansion Tanks:
 - 1. Amtrol Inc.
 - 2. ITT Bell & Gossett
 - 3. Taco, Inc.
 - 4. Armstrong
 - 5. Wessels
- B. Air Vents:
 - 1. Armstrong International, Inc.
 - 2. ITT Bell & Gossett.
 - 3. Taco, Inc.
 - 4. Hoffman
 - 5. Amtrol
 - 6. Metraflex
- C. Centrifugal Air Separator:
 - 1. Armstrong
 - 2. ITT Bell and Gossett
 - 3. Taco, Inc.

4. Amtrol

D. Pressure Reducing Valves:

1. Armstrong
2. ITT Bell and Gossett
3. Taco, Inc.
4. Amtrol
5. Kunkle

E. Liquid Flow Switches:

1. McDonnell & Miller
2. Dwyer
3. Or approved equivalent.

F. Instrument Probe Fittings:

1. Pete's Plug
2. Or approved equivalent.

G. Strainers:

1. Armstrong International
2. Mueller
3. Keckley
4. Hoffman

H. Relief Valves:

1. Armstrong
2. ITT Bell & Gossett
3. Taco
4. Amtrol

2.2 DIAPHRAGM-TYPE EXPANSION TANKS

- A. Construction: Welded steel, tested and stamped in accordance with ASME (BPV VIII, 1); supplied with National Board Form U-1, rated for working pressure of 125 PSI, with flexible EPDM diaphragm sealed into tank, and steel support stand.
- B. Accessories: Pressure gauge and air-charging fitting, tank drain.

2.3 AIR VENTS

- A. Manual Type: Short vertical sections of pipe to form air chamber, with 1/8-inch brass needle valve at top of chamber.
- B. Automatic Float Type: Brass or semi-steel body, copper, polypropylene, or solid non-metallic float, stainless steel valve and valve seat; suitable for system operating temperature and pressure; with isolating valve.

2.4 CENTRIFUGAL AIR SEPARATOR

- A. Description: Fabricated steel tank stamped in accordance with Section VIII of ASME Boiler and Pressure Vessel Code for Unfired Vessels, stamped for 150 PSI, with tangential inlet and outlet connections, internal perforated stainless steel air collector tube and blowdown connection. Provide steel support stand.

2.5 PRESSURE REDUCING VALVES

- A. Brass body, adjustable range, inlet check valves, removable inlet strainer, noncorrosive valve seat and stem, 3/4-inch size unless otherwise shown, factory set at fill pressure as indicated on drawings.

2.6 LIQUID FLOW SWITCHES

- A. Description: Brass for wetted parts with packless construction, paddle with removable segments for pipe size and flow velocity, vapor proof electrical compartment for switches mounted on cold hydronic piping systems, switches for 115V, 60 Hz, 1-phase with 7.4A rating.

2.7 INSTRUMENT PROBE FITTINGS

- A. Brass or stainless steel body and cap, high pressure rated, valve material neoprene, Nordan or Viton to suit temperature range, 1/4-inch or 1/2-inch NPT tailpiece.

2.8 STRAINERS

- A. Size 2-inches and Under: Screwed brass or iron body for 175 PSI working pressure, Y pattern with 1/16-inch stainless steel perforated screen.
- B. Size 2-1/2-inches and Larger: Flanged or grooved and above: iron body for 175 PSI working pressure, Y pattern with 1/16 stainless steel perforated screen.
- C. Basket Pattern: Flanged iron body for 175 PSI working pressure, basket pattern with 1/8-inch stainless steel perforated screen, clamped or bolted cover.

2.9 RELIEF VALVES

- A. Size and capacity as selected by installer for proper relieving capacity, in accordance with ASME Boiler and Pressure Vessel Code.
- B. Combined Pressure-Temperature Relief Valves: Bronze body, test lever, thermostat, complying with ANSI Z21.22 listing requirements for temperature discharge capacity. Provide temperature relief at 210F, and pressure relief at 125 PSI.
- C. Pressure Relief Valves: Bronze body, test lever, ASME rated. Provide pressure relief as indicated on drawings.

PART 3 - EXECUTION

3.1 GENERAL INSTALLATION REQUIREMENTS

- A. Install specialties in accordance with manufacturer's instructions.
- B. Support pump fittings with floor mounted pipe and flange supports. Provide vibration isolation, same as pump, to avoid short circuiting.

3.2 DIAPHRAGM TYPE EXPANSION TANKS

- A. Install tank in accordance with manufacturer's instructions. Charge tank with air per manufacturer's instructions. Prior to making connection from the tank to the system, check the air charge. Valve is to be opened to the system when it is determined that the air pressure is equal to the minimum system pressure at the tank location.

3.3 AIR VENTS

- A. Where large air quantities can accumulate, provide enlarged air collection standpipes.
- B. Automatic: Furnish and install automatic air vents in mechanical equipment rooms and outdoors only. Install at high points of system piping, at heat transfer coils, and elsewhere as required for system air venting. Vents: 3/4-inch with 1/2-inch IPS drain piping to the nearest floor drain or other approved location. Provide a ball valve and union ahead of all automatic air vents. Do not install above ceilings or locations where discharge may occur and cause damage.
- C. Manual Vents: Provide at high points of system piping, at heat transfer coils, and elsewhere as required for system venting where automatic air vents are not to be installed. Provide 10-inch length of 1/4-inch copper tube with 180 degree bend down to discharge into hand-held bucket.

3.4 CENTRIFUGAL AIR SEPARATOR

- A. Install in pump suction lines and as indicated. Run piping to expansion tank with 1/4-inch per foot (2 percent) upward slope towards tank. Install drain valve on units 2-inches and over.

3.5 PRESSURE REDUCING VALVES

- A. Install as indicated, and in accordance with manufacturer's instructions with three valve bypass.

3.6 LIQUID FLOW SWITCHES

- A. Install on inlet to water chiller and on other equipment as indicated. Install in horizontal pipe with switch mounted in tee on top of pipe with minimum of 24 inches of straight pipe with no fitting both upstream and downstream of switch. Remove segments of paddle to fit in accordance with manufacturer's instructions.

3.7 INSTRUMENT PROBE FITTINGS

- A. Test Plugs: Install where indicated and in accordance with the manufacturer's recommendations.

3.8 STRAINERS

- A. Provide valved drain and hose connection on strainer blow down connection.

3.9 RELIEF VALVES

- A. Select system relief valve capacity so that it is greater than make-up pressure reducing valve capacity. Select equipment relief valve capacity to exceed rating of connected equipment.
- B. Pipe relief valve outlet to nearest floor drain.
- C. Where one line vents several relief valves, make cross-sectional area equal to sum of individual vent areas.
- D. Water Relief Valves: Install as indicated, and on expansion tanks, hot water tanks and pressure vessels. Pipe discharge to floor drain. Comply with ASME Boiler and Pressure Vessel Code.

END OF SECTION

SECTION 23 2123 - HYDRONIC PUMPS

PART 1 - GENERAL

1.1 SUMMARY

- A. Work Included:
 - 1. General Pump Requirements
 - 2. In-Line Circulators
 - 3. Vertical In-Line Pumps

1.2 RELATED SECTIONS

- A. Contents of Division 23, HVAC and Division 01, General Requirements apply to this Section.

1.3 REFERENCES AND STANDARDS

- A. References and Standards as required by Section 23 00 00, HVAC Basic Requirements and Division 01, General Requirements.
- B. In addition, meet the following:
 - 1. NEMA MG 1 - Motors and Generators; National Electrical Manufacturers Association, current edition.
 - 2. NEMA OS 1 - Sheet Steel Outlet Boxes, Device Boxes, Covers, and Box Supports; National Electrical Manufacturers Association, current edition.
 - 3. NFPA 70 - National Electrical Code; National Fire Protection Association, current edition.
 - 4. UL 778 - Standard for Motor-Operated Water Pumps; Underwriters Laboratories Inc., current edition.

1.4 SUBMITTALS

- A. Submittals as required by Section 23 00 00, HVAC Basic Requirements and Division 01, General Requirements.
- B. In addition, provide:
 - 1. Product Data: Provide certified pump curves showing performance characteristics with pump and system operating point plotted. Include NPSH curve when applicable. Include electrical characteristics and connection requirements.
 - 2. Manufacturer's Installation Instructions: Indicate hanging and support requirements and recommendations.
 - 3. Millwright's Certificate: Certify that base mounted pumps have been aligned.
 - 4. Operation and Maintenance Data: Include installation instructions, assembly views, lubrication instructions, and replacement parts list.

1.5 QUALITY ASSURANCE

- A. Quality assurance as required by Section 23 00 00, HVAC Basic Requirements and Division 01, General Requirement.
- B. In addition, meet the following:

1. Manufacturer Qualifications: Company specializing in manufacture, assembly, and field performance of pumps, with minimum three years of documented experience.
2. Alignment: Base mounted pumps will be aligned by qualified millwright.

1.6 WARRANTY

- A. Warranty of materials and workmanship as required by Section 23 00 00, HVAC Basic Requirements and Division 01, General Requirements.

1.7 DELIVERY, STORAGE, AND HANDLING

- A. Manufacturer's Preparation for Shipping: Clean flanges and exposed machined metal surfaces and treat with anticorrosion compound after assembly and testing. Protect flanges, pipe openings, and nozzles with wooden flange covers or with screwed-in plugs.
- B. Store pumps in dry location.
- C. Retain protective covers for flanges and protective coatings during storage.
- D. Protect bearings and couplings against damage from sand, grit, and other foreign matter.
- E. Comply with pump manufacturer's written rigging instructions.

1.8 COORDINATION

- A. Coordinate size and location of concrete bases. Cast anchor-bolt inserts into bases.

1.9 EXTRA MATERIALS

- A. Furnish extra materials described below that match products installed and that are packaged with protective covering for storage and identified with labels describing contents.
- B. Mechanical Seals: One mechanical seal for each pump.

1.10 PERFORMANCE REQUIREMENTS

- A. Ensure pumps operate at specified system fluid temperatures without vapor binding and cavitation, are non-overloading in parallel or individual operation, and operate within 25 percent of midpoint of published maximum efficiency curve.

PART 2 - PRODUCTS

2.1 MANUFACTURERS

- A. Armstrong Pumps, Inc.
- B. ITT Bell & Gossett
- C. Taco
- D. Paco

- E. Grundfos
- F. Wilo
- G. Weil
- H. Xylem
- I. Or approved equivalent.

2.2 GENERAL PUMP REQUIREMENTS

- A. Pump Units: Factory assembled and tested.
- B. Motors: Include built-in, thermal-overload protection and grease-lubricated ball bearings. Select each motor to be nonoverloading over full range of pump performance curve.
- C. Motors Indicated to Be Energy Efficient: Minimum efficiency as indicated according to IEEE 112, Test Method B. Provide premium efficiency motors according to IEEE 112, Test Method.

2.3 IN-LINE CIRCULATORS

- A. Type: Horizontal shaft, single stage, direct connected, with resiliently mounted motor for in-line mounting, oil lubricated, for 125 PSI maximum working pressure.
- B. Casing: Cast iron, with threaded companion flanges for piping connections, and threaded gauge tappings at inlet and outlet connections.
- C. Impeller: Cast bronze keyed to shaft, statically and dynamically balanced, closed, overhung, single suction, and keyed to shaft.
- D. Motor Bearings: Oil lubricated bronze sleeve.
- E. Pump Bearings: Oil-lubricated, bronze journal and thrust type.
- F. Shaft: Alloy steel with copper sleeve, integral thrust collar.
- G. Seal: Mechanical seal maximum continuous operating temperature. Include carbon-steel rotating ring, stainless-steel spring, ceramic seat, and flexible bellows and gasket.
- H. Drive: Flexible coupling, capable of absorbing torsional vibration and shaft misalignment.
- I. Motor: Resiliently mounted to pump casing.
- J. Performance Electrical Characteristics:
 - 1. As Scheduled. 1750 RPM motors unless specified otherwise; reference Section 23 05 13, Common Motor Requirements for HVAC Equipment.
 - 2. Wiring Terminations: Provide terminal lugs to match branch circuit conductor quantities, sizes and materials indicated. Enclose terminal lugs in terminal box sized to NFPA 70.

- K. Variable Flow Controller: Provide integral pump speed controller. Pump control based on:
 - 1. Pressure.

2.4 VERTICAL IN-LINE PUMPS

- A. Type: Vertical in-line, centrifugal, single stage, flexible coupled, radially split casing, for in-line mounting, for 125 psi working pressure.
- B. Casing: Cast iron, with suction and discharge gauge port, casing wear ring, seal flush connection, drain plug at low point of volute, flanged suction and discharge.
- C. Impeller: ASTM B584 cast bronze, fully enclosed, keyed directly to motor shaft or extension, statically and dynamically balanced, closed, overhung, single suction.
- D. Shaft: Stainless steel with stainless steel impeller cap screw or nut and bronze sleeve.
- E. Wear Rings: Replaceable, bronze casing ring.
- F. Seal: Mechanical seal, 225 degrees F maximum continuous operating temperature, with carbon-steel rotating ring, stainless-steel spring, ceramic seat, and flexible bellows and gasket.
- G. Seal: Packing gland with minimum four rings graphite impregnated packing and bronze lantern rings, 250 degrees F maximum continuous operating temperature.
- H. Motor: Directly mounted to pump casing and with lifting and supporting lugs in top of motor enclosure.
- I. Performance Electrical Characteristics:
 - 1. As Scheduled. 1750 RPM motors unless specified otherwise; reference Section 23 05 13, Common Motor Requirements for HVAC Equipment.
 - 2. Wiring Terminations: Provide terminal lugs to match branch circuit conductor quantities, sizes, and materials indicated. Enclose terminal lugs in terminal box sized to NFPA 70.
- J. Variable Flow Controller: Provide integral pump speed controller. Pump control based on:
 - 1. Pressure.

PART 3 - EXECUTION

3.1 GENERAL PUMP INSTALLATION

- A. Install in accordance with manufacturer's instructions according to ANSI/HI 1.1-1.5 "Centrifugal Pumps for Nomenclature, Definitions, Application and Operation.
- B. Provide access space around pumps for service including removing motors, impellers, couplings, and accessories. Provide no less than minimum space recommended by manufacturer.
- C. Decrease from line size with long radius reducing elbows or reducers. Eccentric reducers where necessary to prevent air entrapment. Support piping adjacent to pump such that no weight is carried on pump casings. For close coupled or base mounted pumps, provide supports under

elbows on pump suction and discharge line sizes 4-inches and over. Provide vibration isolation to ensure there is no short circuiting of pump vibration isolator.

- D. Unless indicated otherwise on drawings, provide line sized shut-off valve and strainer on pump suction, and line sized soft seat check valve and balancing valve and shut off valve on pump discharge. Triple duty valves not allowed.
- E. Provide totally enclosed fan cooled motors when motor is located outdoors, whether under a cover or not, or exposed to moisture. Provide protective covering for electronically commutated motors located in outdoor or wet/wash-down locations.
- F. Lubricate pumps before start-up.
- G. Piping installation requirements are specified in other Division 23, HVAC Sections. Drawings indicate general arrangement of piping, fittings, and specialties.
- H. Install piping adjacent to pumps to allow service and maintenance.
- I. Connect piping to pumps. Install valves that are the same size as piping connected to pumps.
- J. Install suction and discharge pipe sizes equal to or greater than diameter of pump nozzles.
- K. Install flexible connectors on suction and discharge sides of base-mounted pumps between pump casing and valves.
- L. Install pressure gauges and temperature gauges on pump suction and discharge. Install at integral pressure-gauge tappings where provided.
- M. Install temperature and pressure-gauge connector plugs in suction and discharge piping around each pump.
- N. Install electrical connections for power, controls, and devices.
- O. Electrical power and control wiring and connections are specified in Division 26, Electrical Sections.
- P. Ground equipment.
- Q. Tighten electrical connectors and terminals according to manufacturer's published torque-tightening values. If manufacturer's torque values are not indicated, use those specified in UL 486A and UL 486B.
- R. Engage a factory-authorized service representative to train Owner's maintenance personnel to adjust, operate, and maintain hydronic pumps as specified below:
 - 1. Train Owner's maintenance personnel on procedures and schedules for starting and stopping, troubleshooting, servicing, and maintaining pumps.
 - 2. Review data in maintenance manuals. Reference Division 01, General Requirements.
 - 3. Schedule training with Owner, through Architect, with at least seven days' advance notice.

- S. Examine equipment foundations and anchor -bolt locations for compliance with requirements for installation.
 - 1. Examine roughing-in for piping systems to verify actual locations of piping connections before pump installation.
 - 2. Examine foundations and inertia bases for suitable conditions where pumps are to be installed.
- T. Proceed with installation only after unsatisfactory conditions have been corrected.

3.2 IN-LINE CIRCULATORS INSTALLATION

- A. Install per manufacturer's written instructions and requirements.

3.3 VERTICAL IN-LINE PUMPS INSTALLATION

- A. Install per manufacturer's written instructions and requirements.

END OF SECTION

SECTION 23 2500 - HVAC WATER TREATMENT

PART 1 - GENERAL

1.1 SUMMARY

- A. Work Included:
 - 1. Chemical Feed Description
 - 2. Chemical Feeding Equipment
 - 3. Chemical Treatment Test Equipment
 - 4. Chemicals
 - 5. Glycol-Water System
 - 6. Supplemental Services/Components

1.2 RELATED SECTIONS

- A. Contents of Division 23, HVAC and Division 01, General Requirements apply to this Section.

1.3 REFERENCES AND STANDARDS

- A. References and Standards as required by Section 23 00 00, HVAC Basic Requirements and Division 01, General Requirements.

1.4 SUBMITTALS

- A. Submittals as required by Section 23 00 00, HVAC Basic Requirements and Division 01, General Requirements.
- B. In addition, provide:
 - 1. Product Data: Include rated capacities; water-pressure drops; shipping, installed, and operating weights; and furnished products listed below:
 - a. Pumps
 - b. Chemical Solution Tanks
 - c. Agitators
 - d. Control Equipment and Devices
 - e. Test Equipment
 - f. Chemicals
 - g. Filters
 - h. Chemical Feeders
 - i. Glycol-Water System Materials and Equipment
 - j. Shop Drawings: Detail equipment assemblies indicating dimensions, weights, loads, required clearances, method of field assembly, components, and location and size of each field connection.
 - k. Wiring Diagrams: Detail power and control wiring and differentiate between manufacturer-installed and field-installed wiring.
 - l. Water Analysis: Submit a copy of the water analysis to illustrate water quality available at Project site.
 - m. Field Test Reports: Indicate and interpret test results for compliance with performance requirements.

- n. Maintenance Data: For pumps, agitators, filters, system controls, and accessories to include in maintenance manuals specified in Division 01, General Requirements.

1.5 QUALITY ASSURANCE

- A. Quality assurance as required by Section 23 00 00, HVAC Basic Requirements and Division 01, General Requirements.
- B. In addition, meet the following:
 1. Qualifications: Firms regularly engaged in manufacture of components of types and sizes required.
 2. Installer Qualifications: An experienced installer who is an authorized representative of the chemical treatment manufacturer for both installation and maintenance of chemical treatment equipment required for this Project.
 3. Electrical Components, Devices, and Accessories: Listed and labeled as defined in NFPA by a testing agency acceptable to authorities having jurisdiction, and marked for intended use.

1.6 WARRANTY

- A. Warranty of materials and workmanship as required by Section 23 00 00, HVAC Basic Requirements and Division 01, General Requirements.

1.7 PERFORMANCE REQUIREMENTS

- A. Maintain water quality for HVAC systems that controls corrosion and build-up of scale and biological growth for maximum efficiency of installed equipment without posing a hazard to operating personnel or the environment.
- B. Base chemical treatment performance requirements on quality of water available at Project site, HVAC system equipment material characteristics and functional performance characteristics, operating personnel capabilities, and requirements and guidelines of authorities having jurisdiction. Consult equipment manufacturer prior to acceptance of values noted below.
 1. Closed System: Maintain system essentially free of scale, corrosion, and fouling to sustain the following water characteristics:
 - a. pH: Maintain a value within 9.0 to 10.5.
 - b. "P" Alkalinity: Maintain a value within 100 to 500 ppm.
 - c. Boron: Maintain a value within 100 to 200 ppm.
 - d. Chemical Oxygen Demand: Maintain a maximum value of 100 ppm.
 - e. Soluble Copper: Maintain a maximum value of 0.20 ppm.
 - f. TDS: Maintain a maximum value of 10ppm.
 - g. Ammonia: Maintain a maximum value of 20 ppm.
 - h. Free Caustic Alkalinity: Maintain a maximum value of 20 ppm.
 - i. Microbiological Limits:
 - 1) Total Aerobic Plate Count: Maintain a maximum value of 1000 organisms/ml.
 - 2) Total Anaerobic Plate Count: Maintain a maximum value of 100 organisms/ml.
 - 3) Nitrate Reducers: Maintain a maximum value of 100 organisms/ml.
 - 4) Sulfate Reducers: Maintain a maximum value of 0 organisms/ml.

- 5) Iron Bacteria: Maintain a maximum value of 0 organisms/ml.
2. Steam and Condensate Piping System: Maintain system essentially free of scale, corrosion, total suspended solids, and fouling to sustain the following water characteristics:
 - a. pH: Maintain a value within 7 to 8.
 - b. Calcium Carbonate Hardness: Maintain a value within 100 to 300 ppm.
 - c. Calcium Carbonate Alkalinity: Maintain a value within 100 to 300 ppm.
3. Small, Open Systems for Humidifiers, Air Washers, Evaporative Condensers, and Cooling Towers smaller than 50 tons: Maintain system essentially free of scale, total suspended solids, and fouling to sustain the following water characteristics:
 - a. pH: Maintain a value within 8.0 to 9.1.
 - b. "P" Alkalinity: Maintain a maximum value of 100 ppm.
 - c. Chemical Oxygen Demand: Maintain a maximum value of 100 ppm.
 - d. Soluble Copper: Maintain a maximum value of 0.20 ppm.
 - e. TDS: Maintain a maximum value of 10 ppm.
 - f. Ammonia: Maintain a maximum value of 20 ppm.
 - g. Free "OH" Alkalinity: Maintain a maximum value of 0 ppm.
 - h. Microbiological Limits:
 - 1) Total Aerobic Plate Count: Maintain a maximum value of 10,000 organisms/ml.
 - 2) Total Anaerobic Plate Count: Maintain a maximum value of 1000 organisms/ml.
 - 3) Nitrate Reducers: Maintain a maximum value of 100 organisms/ml.
 - 4) Sulfate Reducers: Maintain a maximum value of 0 organisms/ml.
 - 5) Iron Bacteria: Maintain a maximum value of 0 organisms/ml.
 - i. Polymer Testable: Maintain a minimum value within 10 to 40.
4. Condenser Water, Medium-to-Large Cooling Tower System (over 50 tons): Maintain system essentially free of scale and total suspended solids to sustain the following water characteristics:
 - a. pH: Maintain a value within 8.0 to 9.1.
 - b. "P" Alkalinity: Maintain a maximum value of 100 ppm.
 - c. Chemical Oxygen Demand: Maintain a maximum value of 100 ppm.
 - d. Soluble Copper: Maintain a maximum value of 0.20 ppm.
 - e. TDS: Maintain a maximum value of 10 ppm.
 - f. Ammonia: Maintain a maximum value of 20 ppm.
 - g. Free "OH" Alkalinity: Maintain a maximum value of 0 ppm.
 - h. Microbiological Limits:
 - 1) Total Aerobic Plate Count: Maintain a maximum value of 10,000 organisms/ml.
 - 2) Total Anaerobic Plate Count: Maintain a maximum value of 1000 organisms/ml.
 - 3) Nitrate Reducers: Maintain a maximum value of 100 organisms/ml.
 - 4) Sulfate Reducers: Maintain a maximum value of 0 organisms/ml.
 - 5) Iron Bacteria: Maintain a maximum value of 0 organisms/ml.
 - i. Polymer Testable: Maintain a minimum value within 10 to 40.
5. Passivation for Galvanized Steel (for the first 60 days of operation):
 - a. pH: Maintain a value within 7 to 8.
 - b. Calcium Carbonate Hardness: Maintain a value within 100 to 300 ppm.
 - c. Calcium Carbonate Alkalinity: Maintain a value within 100 to 300 ppm.

1.8 MAINTENANCE

- A. Scope of Service: Provide chemicals and service program for maintaining optimum conditions in the circulating water for inhibiting corrosion, scale, and organic growths in the cooling, chilled-water piping, heating hot-water piping, heating, steam and condensate piping, steam and condensate system for humidifier and cooking appliance applications, and condenser water piping and equipment. Services and chemicals provided for a period of one year from date of Substantial Completion, including the following:
1. Initial water analysis and recommendations.
 2. Startup assistance.
 3. Periodic field service and consultation.
 4. Customer report charts and log sheets.
 5. Laboratory technical assistance.
 6. Analyses and reports of chemical items concerning safety and compliance with government regulations.

1.9 EXTRA MATERIALS

- A. Furnish extra materials described below that match products installed and that are packaged with protective covering for storage and identified with labels describing contents.
1. Chemicals: Furnish quantity equal to 50 percent of amount initially installed.

PART 2 - PRODUCTS

2.1 ACCEPTABLE MANUFACTURERS

- A. Aqua-Chem, Inc.; Cleaver-Brooks Div.
- B. Betz Dearborn, Inc.
- C. Calgon Corp., ECC International
- D. ITOH2 Industrial Treatment of Water
- E. Nalco Chemical Co.
- F. US Water Services
- G. Chemcoa
- H. Cleaver-Brooks
- I. Sarco
- J. Or approved equivalent.

2.2 CHEMICAL FEED DESCRIPTION

- A. Closed-Loop System: One bypass feeder on each system with isolating and drain valves downstream from circulating pumps, unless otherwise indicated.

1. Introduce chemical treatment through bypass feeder when required or indicated by test.
 2. Where a switch-over HVAC system is being utilized, coordinate treatment of both closed loop systems (chilled water and heating water) to verify compatibility of chemicals and longevity of piping distribution system. Dual hot/chilled water systems treated with borax/nitrite to be treated with a biocide.
- B. Closed-Loop, Heating Steam and Condensate Piping: Lead-lag switch controls the sequence of boilers and introduces the chemical to the boiler through a bypass feeder.
1. Chemical feed pump introduces sequestering agent and base from solution tank into boiler, steam header, condensate tank, or feedwater line close to boiler, with minimum of one pump per boiler. Use agitator as required.
 2. Select required location for oxygen scavenger feed below. Feed can be into deaerator storage tank, feedwater tank, or feedwater line as far as possible from boiler.
 3. Pump oxygen scavenger feed from solution tank into deaerator storage tank, feedwater tank, or feedwater line as far as possible from boiler. Use agitator as required.
 4. Select required location for solution feed of neutralizing amine below. Feed can be into boiler, steam header, condensate tank, or feedwater line close to boiler.
 5. Feed carbon dioxide, neutralizing amine from solution tank directly into boiler, steam header, condensate tank, or feedwater line close to boiler, or filming amine into steam header. Use agitator as required.
 6. Activate chemical solution pump when feedwater pumps are running.
 7. Activate chemical solution pump from meter on makeup water line only when one boiler is used.
 8. Continuously run pump for feeding chemical when multiple boilers are used.
 9. Liquid-level switch, in each solution tank, deactivates chemical solution pump and signals alarm.
 10. Conductivity controller samples boiler water on timed cycle and operates solenoid blowdown valve.
- C. Open-Loop Systems for Humidifiers, Air Washers, Evaporative Condensers, and Cooling Towers: Drip feeders, Polypropylene mesh bags, or PVC tubing with hole to feed chemical.
1. Conductivity controller samples sump water when activated by pump and operates solenoid bleed-off valve in line to drain.
- D. Open-Loop, Condenser Water Piping: Pump sequestering agent and corrosion inhibitor from solution tank into condenser water supply to tower. Use agitator as required.
1. Intermittently feed biocide to condenser water to achieve a toxic level of the chemical to kill the organism present.
 2. Change biocides periodically to avoid chemical immunity.
 3. Activate chemical solution pump from water meter in makeup water line to cooling tower when condenser water pumps are running.
 4. Automatically feed chemical with electronic solid-state controllers.
 5. Deactivate solution pump and signal alarm by a liquid-level switch in each solution tank on low chemicals.
- E. Existing Systems:
1. Prior to filling new hydronic distribution systems, verify existing chemical treatment system is adequate for installed system pipe longevity.
 2. Confirm existing chemical compatibility. Where a switch-over HVAC system is being utilized, coordinate treatment of both closed loop systems (chilled water and heating

water) to verify compatibility of chemicals and longevity of piping distribution system.
Dual hot/chilled water systems treated with borax/nitrite to be treated with a biocide

2.3 CHEMICAL FEEDING EQUIPMENT

- A. Bypass Feeders: Cast iron or steel, for introducing chemicals into system; with funnel shutoff valve on top, air-release valve on top, drain valve on bottom, and recirculating shutoff valves on sides.
 - 1. Capacity: 1.8 gallon for systems with less than 1,000 gallon volume and 5 gallon for systems with more than 1,000 gallon volume.
 - 2. Working Pressure: 125 PSIG or 175 PSIG.
- B. Drip Feeders: Plastic reservoir with capillary tubing probe, weight, charging syringe, and clip.
- C. Positive-Displacement Diaphragm Pump: Simplex, self-priming, rated for intended chemical with 25 percent safety factor for design pressure and temperature.
 - 1. Adjustable flow rate.
 - 2. Thermoplastic construction.
 - 3. Fully enclosed, continuous-duty, 120-V, 60-Hz, single-phase motor.
 - 4. Built-in relief valve.
 - 5. Retain pump type in paragraph above or below. Use diaphragm pump for normal operating pressures. Use piston pump for higher operating pressures.
- D. Positive-Displacement Piston Pump: Metal and thermoplastic construction.
 - 1. Fully enclosed, continuous-duty, 120-V, 60-Hz, single-phase motor.
 - 2. Built-in relief valve.
- E. Chemical Solution Tanks: Chemical-resistant reservoirs fabricated from high-density opaque polyethylene with graduated markings.
 - 1. Molded fiberglass cover with recess for mounting pump, agitator, and liquid-level switch.
 - 2. Capacity: 30 gallon or 50 gallon.
 - 3. Secondary containment spill pallets for chemical solution tanks:
 - a. Material: Polyethylene.
 - b. Capacity: 66 gallons each.
 - c. Provide each pallet with grating and drain plug.
 - d. Provide one portable loading ramp.
 - e. Quantity: Two.
- F. Agitator: Direct drive, 1750 rpm, mounted on tank with angle adjustment.
 - 1. Fully enclosed, continuous-duty, 120-V, 60-Hz, single-phase motor.
 - 2. Stainless-steel clamp and motor mount, with stainless-steel shaft and propeller.
- G. Liquid-Level Switch: Polypropylene housing, integrally mounted PVC air trap, receptacles for connection to metering pump, and low-level alarm.
- H. Packaged Conductivity Controller: Solid-state circuitry, 5 percent accuracy, linear dial adjustment, built-in calibration switch, on-off switch and light, control-function light, output to control circuit, and recorder.

- I. Cold-Water Meter: Positive-displacement type with sealed, tamperproof magnetic drive; impulse contact register; single-pole, double-throw, dry-contact switch.
 - 1. Rotating-disc or Turbine type with bronze or cast-iron body rated for 125 PSIG (860 kPa).
 - 2. Magnetic-drive or mechanical-impulse contactor matched to signal receiver.
 - 3. At least six-digit totalizers.
 - 4. 120-V ac.
- J. Solenoid Valves: Forged-brass body, globe pattern, and general-purpose solenoid enclosure with 120-V, continuous-duty coil.
- K. Electronic Timers: 150-second and 5-minute ranges, with infinite adjustment over full range, and mounted in cabinet with hand-off-auto switches and status lights.
- L. Chemical Tubing: Schedule 40, PVC with solvent-cement joints; or polypropylene tubing with heat fusion.
- M. Plastic Ball Valves: Rigid PVC or CPVC body, integral union ends, and polytetrafluoroethylene seats and seals.
- N. Plastic-Body Strainer: Rigid PVC or CPVC with cleanable stainless-steel strainer element.
- O. Condenser Water-Treatment Control Panel: Incorporate solid-state integrated circuits and digital LED displays, in NEMA 250, Type 12 enclosure with gasketed and lockable door. Provide alarm outputs to building automation system.
 - 1. Control dissolved solids, based on conductivity, and include the following:
 - a. Digital readout display.
 - b. Temperature-compensated sensor probe adaptable to sample stream manifold.
 - c. High, low, and normal conductance indicator lights.
 - d. High or low conductance alarm light, trip points field adjustable; with silence switch.
 - e. Hand-off-auto switch for solenoid bleed-off valve.
 - f. Bleed-off light to indicate valve operation.
 - g. Internal adjustable hysteresis or dead band.
 - 2. Control inhibitor feeding, based on makeup volume, and include the following:
 - a. Solid-state reset counter (accumulator), with selections from 1 to 15.
 - b. Solid-state timer, adjustable from 15 to 300 seconds.
 - c. Test switch.
 - d. Hand-off-auto switch for chemical pump.
 - e. Illuminated legend to indicate feed when pump is activated.
 - f. Solid-state lockout timer, adjustable from 15 to 180 minutes, with indicator light. Lockout timer to deactivate the pump and activate alarm circuits.
 - g. Electromechanical-type, panel-mounted makeup totalizer to measure amount of makeup water.
 - 3. Control biocide with an adjustable time programmer and include the following:
 - a. 24-hour timer with 14-day skip feature to permit activation any hour of day.
 - b. Precision, solid-state, bleed-off lockout timer (zero to nine hours) and clock-controlled biocide pump timer (zero to two and one-half hours). Prebleed and bleed lockout.

- c. Solid-state alternator to enable the use of two different formulations.
- d. 24-hour digital display of time of day.
- e. 14-day LED display of day of week.
- f. Fast and slow internal clock set controls.
- g. Battery backup so clock is not disturbed by power outages.
- h. Quartz timekeeping accuracy.
- i. Hand-off-auto switches for biocide pumps.
- j. Biocide A and Biocide B illuminated legends to indicate pump is running.

2.4 CHEMICAL TREATMENT TEST EQUIPMENT

- A. Test Kit: Manufacturer recommended equipment and chemicals, in a carrying case, for testing pH, total dissolved solids, dissolved oxygen, biocount, chloride, and total alkalinity and for calcium hardness field tests.
- B. Corrosion Test Coupon Assembly: Constructed of corrosion material, complete with piping, valves, and mild steel and copper coupons. Locate copper coupon downstream from mild steel coupon in the test coupon assembly.
 - 1. Two station rack for closed-loop systems.
 - 2. Four station rack for open condenser water systems.

2.5 CHEMICALS

- A. Furnish chemicals recommended by water-treatment system manufacturer that are compatible with piping system components and connected equipment.
- B. System Cleaner: Liquid alkaline compound with emulsifying agents and detergents to remove grease and petroleum products.
- C. Biocide: Chlorine release agents or microbiocides.
- D. Closed-Loop, Water Piping Chemicals: Sequestering agent to reduce deposits and adjust pH, corrosion inhibitors, and conductivity enhancers.
- E. Heating Steam and Condensate Piping Chemicals: Sequestering agent to reduce hardness and prevent feedline congestion and to provide alkalinity, oxygen scavenger, carbon-dioxide neutralizer, and filming amines.
- F. Open-Loop, Condenser Water Piping Chemicals: Sequestering agent to inhibit scaling, acid to reduce alkalinity and pH, corrosion inhibitor, and biocide.
- G. Open-Loop Piping Chemicals Serving Humidifiers, Air Washers, Evaporative Condensers, Small Cooling Towers, and Liquid Coolers: Sequestering agent to inhibit scaling, corrosion inhibitor, and biocide nonoxidizing.

2.6 GLYCOL-WATER SYSTEM

- A. Propylene glycol to be inhibited with 1.75 percent dipotassium phosphate. Do not use automotive anti-freeze because the inhibitors used are not needed and can cause sludge precipitate that interferes with heat transfer.

- B. Provide required amount of glycol to obtain the percent by volume for glycol-water systems as follows and to provide one-half tank reserve supply: 25 percent for run-around coil systems, chilled water system, or hydronic system.
- C. Pot Feeder Make-up Unit: By pass type for chemical treatment, schedule 10 gauge heads, 3/4-inch system connections and large neck opening for chemical addition. Feeders to be 5 gallons minimum size.
- D. Glycol-Water Make-up System:
 - 1. Glycol-Water storage tank: Self supporting polyethylene, minimum 90 mil thickness, with removable cover or black steel with 90 mil polyethylene insert. Capacity to be 55 gallons, with approximate diameter of 23-inches and height of 36-inches. Reinforced threaded pipe connections to be provided for connections. Provide identification for tank showing name of the contents.
 - 2. Glycol-Water make-up pump: Bronze fitted, self priming, high head type suitable for pumping a 33 percent to 50 percent glycol-water solution in intermittent service. The pump to be provided with a mechanical shaft seal and be flange connected to a 1750 rpm NEMA Type C motor. The pump capacity to be 3 gpm or 50 PSIG discharge pressure with a suction lift capability of 5-inches of mercury, with a 1/3 horsepower drip proof motor. The pump may be a "gear-within-a-gear" positive displacement type with built-in relief valve set for 43 PSIG, or the pump may be a regenerative turbine type providing self-priming with built-in relief valve set for 43 PSIG, or the pump may be a regenerative turbine type providing self-priming with built-in or external relief valve set for design head of the pump.
 - 3. Back pressure regulating valve: Spring loaded, diaphragm actuated type with bronze or steel body, stainless steel trim with capacity to relieve 100 percent of pump flow with an allowable rise in the regulated pressure of 10 PSIG above the set point. Set point to be 15 PSIG above system PRV setting.
 - 4. Low water level control: Steel or plastic float housing, stainless steel or plastic float, positive snap acting SPST switch mechanism, rated 10 amps-120 volt AC, in General Purpose (NEMA 1) enclosure. the control to be rated for pressures to 150 PSIG and make alarm circuit on low water level. The alarm circuit to be wired to an alarm light on the nearest local Temperature Control panel (LTCP). Provide remote output relay to indicate alarm condition at the Building Control System.

2.7 SUPPLEMENTAL COMPONENTS/SERVICES

- A. Drain and makeup water piping to comply with the requirements of Division 22, Plumbing. Drains which connect to sanitary sewer systems to be connected by means of an indirect waste.

PART 3 - EXECUTION

3.1 GENERAL INSTALLATION REQUIREMENTS

- A. Water Analysis:
 - 1. Perform an analysis of supply water to determine the type and quantities of chemical treatment needed to maintain the water quality as specified in "Performance Requirements" Article.
 - 2. Existing Systems:

- a. Prior to filling new hydronic distribution systems, verify existing chemical treatment system is adequate for installed system pipe longevity.
 - b. Confirm existing chemical compatibility. Where a switch-over HVAC system is being utilized, coordinate treatment of both closed loop systems (chilled water and heating water) to verify compatibility of chemicals and longevity of piping distribution system.
- B. Installation:
1. Install treatment equipment level and plumb. Provide power to all system devices.
 2. Add cleaning chemicals as recommended by manufacturer.
 3. To prevent dirt and solids from lodging the coils, before adding cleaning chemical to the closed system, air handling coils and fan coil units to be isolated by closing the inlet and outlet valves and opening the bypass valves. Do not valve in or operate system pumps until after system has been cleaned.
 4. After chemical cleaning is satisfactorily completed, open the inlet and outlet valves to each coil and close the by-pass valves. Also, clean strainers.
- C. Connections:
1. Piping installation requirements are specified in other Division 23, HVAC Sections. Drawings indicate general arrangement of piping, fittings, and specialties.
 2. Provide a by-pass line around water meters and bleed off piping assembly. Provide ball valves to allow for bypassing, isolation, and servicing of components.
 3. Bleed off water piping with bleed off piping assembly to be piped from pressure side of circulating water piping to a convenient drain. Bleed off connection to main circulating water piping to be upstream of chemical injection nozzles.
 4. Provide piping for the flow assembly piping to the main control panel and accessories.
 - a. The inlet piping to connect to the discharge side of the circulating water pump.
 - b. Piping to connect to the water piping service the cooling tower downstream of the heat source.
 - c. Provide inlet Y-strainer and ball valves to isolate and service main control panel and accessories.
 - d. Install injection nozzles with corporation stops in the water piping service the cooling tower downstream of the heat source.
 - e. Provide piping for corrosion monitor rack per manufacturer's installation instructions. Provide ball valves to isolate and service rack.
 - f. Provide piping for erosion chemical feeder per manufacturer's installation instructions. Provide ball valves to isolate and service feeder.
 5. Install piping adjacent to equipment to allow service and maintenance.
 6. Confirm applicable electrical requirements in Division 26, Electrical Sections for connecting electrical equipment.
 7. Ground equipment.
 - a. Tighten electrical connectors and terminals according to manufacturer's published torque-tightening values. If manufacturer's torque values are not indicated, use those specified in UL 486A and UL 486B.
- D. Field Quality Control:
1. Inspect field-assembled components and equipment installation, including piping and electrical connections. Report results in writing.

- a. Inspect piping and equipment to determine that systems and equipment have been cleaned, flushed, and filled with water, and are fully operational before introducing chemicals for water-treatment system.
 - b. Place HVAC water-treatment system into operation and calibrate controls during the preliminary phase of HVAC systems' startup procedures.
 2. Test chemical feed piping as follows:
 - a. Do not enclose, cover, or put piping into operation until it is tested and satisfactory test results are achieved.
 - b. Test for leaks and defects. If testing is performed in segments, submit separate report for each test, complete with diagram of portion of piping tested.
 - c. Leave uncovered and unconcealed new, altered, extended, and replaced water piping until it has been tested and approved. Expose work that has been covered or concealed before it has been tested and approved.
 - d. Cap and subject piping to static water pressure of 50 PSIG (345 kPa) above operating pressure, without exceeding pressure rating of piping system materials. Isolate test source and allow test pressure to stand for four hours. Leaks and loss in test pressure constitute defects.
 - e. Repair leaks and defects with new materials and retest piping until satisfactory results are obtained.
 - f. Prepare test reports, including required corrective action.
- E. Adjusting:
1. Sample boiler water at one-week intervals after boiler startup for a period of five weeks, and prepare certified test report for each required water performance characteristic. Where applicable, comply with ASTM D 3370 and the following standards:
 - a. Silica: ASTM D 859.
 - b. Steam System: ASTM D 1066.
 - c. Acidity and Alkalinity: ASTM D 1067.
 - d. Iron: ASTM D 1068.
 - e. Water Hardness: ASTM D 1126.
 2. Occupancy Adjustments: Within 12 months of Substantial Completion, perform two separate water analyses to prove that automatic chemical feed systems are maintaining water quality within performance requirements specified in this Section. Perform analyses at least 60 days apart. Submit written reports of water analysis.
- F. Gauge Adjusting and Cleaning:
1. Adjust faces of meters and gauges to proper angle for best visibility.
 2. Clean windows of meters and gauges and factory finished surfaces. Replace cracked or broken windows, repair scratched or marred surfaces with manufacturer's touch-up paint.
- G. Demonstration:
1. Engage a factory-authorized service representative to train Owner's maintenance personnel to adjust, operate, and maintain HVAC water-treatment systems and equipment.
 - a. Train Owner's maintenance personnel on procedures and schedules for starting and stopping, troubleshooting, servicing, and maintaining equipment and schedules.
 2. Review manufacturer's safety data sheets for handling of chemicals.
 3. Review data in maintenance manuals, especially data on recommended parts inventory and supply sources and on availability of parts and service.

4. Schedule at least four hours of training with Owner, through Architect, with at least seven days' advance notice.

END OF SECTION

SECTION 23 3100 - HVAC DUCTS AND CASINGS

PART 1 - GENERAL

1.1 SUMMARY

- A. Work Included:
 - 1. Ductwork, Joints and Fittings
 - 2. Laundry Clothes Dryer Vent
 - 3. Insulated Flexible Duct
 - 4. Drain Pans
 - 5. Ductwork Joint Sealers and Sealants

1.2 RELATED SECTIONS

- A. Contents of Division 23, HVAC and Division 01, General Requirements apply to this Section.
- B. In addition, reference the following:
 - 1. Section 23 05 29, Hangers and Supports for HVAC Piping, Ductwork and Equipment.
 - 2. Section 23 05 93, Testing, Adjusting, and Balancing for HVAC.

1.3 REFERENCES AND STANDARDS

- A. References and Standards as required by Section 23 00 00, HVAC Basic Requirements and Division 01, General Requirements.

1.4 SUBMITTALS

- A. Submittals as required by Section 23 00 00, HVAC Basic Requirements and Division 01, General Requirements.
- B. In addition, provide:
 - 1. Welding Certificates
 - 2. Field Quality Control Reports

1.5 QUALITY ASSURANCE

- A. Quality assurance as required by Section 23 00 00, HVAC Basic Requirements and Division 01, General Requirements.
- B. In addition, meet the following:
 - 1. NFPA Compliance:
 - a. NFPA 90A Installation of Air Conditioning and Ventilating Systems.
 - b. NFPA 90B, Installation of Warm Air Heating and Air Conditioning Systems.
 - 2. Comply with NFPA 96, Ventilation Control and Fire Protection of Commercial Cooking Operations, Ch. 3, Duct System for range hood ducts, unless otherwise indicated.
 - 3. Comply with SMACNA's HVAC Duct Construction Standards - Metal and Flexible for acceptable materials, material thicknesses, and duct construction methods, unless otherwise indicated. Provide sheet metal materials free of pitting, seam marks, roller marks, stains, discolorations, and other imperfections.

4. Provide ductwork pressure testing and leakage testing per Section 23 05 93, Testing, Adjusting and Balancing for HVAC.

1.6 WARRANTY

- A. Warranty of materials and workmanship as required by Section 23 00 00, HVAC Basic Requirements and Division 01, General Requirements.

1.7 SYSTEM DESCRIPTION

- A. Duct system design, as indicated, has been used to select size and type of air-moving and distribution equipment and other air system components. Duct design is generally diagrammatic and is not meant to be scaled. Major changes to layout or configuration of duct system must be specifically approved in writing by Architect. Accompany requests for layout modifications with calculations showing that proposed layout will provide original design results without increasing system total pressure.

PART 2 - PRODUCTS

2.1 MANUFACTURERS

- A. Ductwork, Joints, and Fittings:
 1. Ductmate
 2. Lindab Inc
 3. Nexus Inc
 4. SEMCO
 5. United McGill Corporation
 6. Ward Industries
- B. Insulated Flexible Duct:
 1. ATCO
 2. Flexmaster
 3. J.P. Lamborn Co.
 4. Hart and Cooley
- C. Ductwork Joint Sealers and Sealants
 1. Ductmate
 2. Durodyne
 3. Hardcast
 4. United McGill Corporation
 5. Vulkem
 6. Foster
 7. Childer

2.2 DUCTWORK, JOINTS AND FITTINGS

- A. Materials:
 1. Galvanized Steel Ducts: Hot-dipped galvanized steel sheet, lock-forming quality, ASTM A 653/A 653M FS Type B, with G90/Z275 coating. Ducts to have mill phosphatized finish for surfaces exposed to view.

2. Aluminum Ducts: ASTM B 209 (ASTM B 209M); aluminum sheet, alloy 3003-H14. Aluminum Connectors and Bar Stock: Alloy 6061-T651 or of equivalent strength with mill finish for concealed ducts and standard, 1-side bright finish for exposed ducts with liquid-tight joints when containing condensate vapor or liquids in suspension.
 3. Stainless Steel: Fabricated in accordance with ASTM A167 and A480 with liquid-tight joints when containing condensate vapor or liquids in suspension.
- B. Fabricate ducts, elbows, transitions, offsets, branch connections, and other construction according to SMACNA's HVAC Duct Construction Standards - Metal and Flexible and complying with requirements for metal thickness, reinforcing types and intervals, tie-rod applications, and joint types and intervals.
1. Lengths: Fabricate rectangular ducts in lengths appropriate to reinforcement and rigidity class required for pressure class.
 2. Deflection: Duct systems not-to-exceed deflection limits according to SMACNA's HVAC Duct Construction Standards - Metal and Flexible.
 3. Transverse Joints: Prefabricated slide-on joints and components constructed using manufacturer's guidelines for material thickness, reinforcement size and spacing, and joint reinforcement.
- C. Formed-On Flanges: construct according to SMACNA's HVAC Duct Construction Standards - Metal and Flexible, Figure 1-4, using corner, bolt, cleat, and gasket details.
1. Duct Size: Maximum 30-inches wide and up to 2-inch wg pressure class.
 2. Longitudinal Seams: Pittsburgh lock sealed with noncuring polymer sealant.
 3. Cross Breaking or Cross Beading: Cross break or cross bead duct sides 19-inches and larger and 0.0359-inch thick or less, with more than 10 SF of nonbraced panel area unless ducts are lined.
- D. Round, Spiral Lock-Seam Ducts: Fabricate supply ducts of material specified in this Section according to SMACNA's HVAC Duct Construction Standards - Metal and Flexible.
1. Ducts up to 20-inches in Diameter: Interior, center-beaded slip coupling, sealed before and after fastening, attached with sheet metal screws.
 2. Ducts 21- to 72-inches in Diameter: Three-piece, gasketed, flanged joint consisting of two internal flanges with sealant and one external closure band with gasket.
 3. Ducts Larger than 72-inches in Diameter: Companion angle flanged joints per SMACNA HVAC Duct Construction Standards-Metal and Flexible, Figure 3-2.
 4. Round Ducts: Prefabricated connection system consisting of double-lipped, EPDM rubber gasket. Manufacture ducts according to connection system manufacturer's tolerances.
- E. 90-Degree Tees and laterals and Conical Tees: Fabricate to comply with SMACNA's HVAC Duct Construction Standards-Metal and Flexible, with metal thicknesses specified for longitudinal-seam straight ducts.
- F. Diverging-Flow Fittings: Fabricate with reduced entrance to branch taps and with no excess material projecting from fitting onto branch tap entrance.
- G. Fabricate elbows using die-formed, gored, pleated, or mitered construction. Bend radius of die-formed, gored, and pleated elbows to be 1.5 times duct diameter. Unless elbow construction type is indicated, fabricate elbows as follows:

1. Mitered-Elbow Radius and Number of Pieces: Welded construction complying with SMACNA's HVAC Duct Construction Standards-Metal and flexible, unless otherwise indicated.
2. Round Mitered Elbows: Welded construction with the following metal thickness for pressure classes from minus 2- to plus 2-inch wg (minus 500 to plus 500 Pa):
 - a. Ducts 3- to 36-inches in Diameter: 0.034-inch .
 - b. Ducts 37- to 50-inches in Diameter: 0.040-inch.
 - c. Ducts 52- to 60-inches in Diameter5: 0.052-inch.
 - d. Ducts 62- to 84-inches in diameter: 0.064-inch.
3. Round Mitered Elbows: Welded construction with the following metal thickness for pressure classes from 2- to 10-inch wg:
 - a. Ducts 3- to 26-inches in Diameter: 0.034-inch.
 - b. Ducts 27- to 50-inches in Diameter: 0.040-inch.
 - c. Ducts 52- to 60-inches in Diameter: 0.052-inch.
 - d. Ducts 62- to 84-inches in Diameter: 0.064-inch.
4. 90-Degree, Two-Piece, Mitered Elbows: Use only for supply systems or for material-handling Class A or B exhaust systems and only where space restrictions do not permit using radius elbows. Fabricate with single-thickness turning vanes.
5. Round Elbows
 - a. 8-inches and Less in Diameter: Fabricate die-formed elbows for 45 and 90-degree elbows and pleated elbows for 30, 45, 60 and 90 degrees only. Fabricate nonstandard bend-angle configurations or non-standard diameter elbows with gored construction.
 - b. 9 through 14-inches in Diameter: Fabricate gored or pleated elbows for 30, 45, 60 and 90 degrees unless space restrictions require mitered elbows. Fabricate nonstandard bend-angle configurations or nonstandard diameter elbows with gored construction.
 - c. Larger than 14-inches in Diameter and All Flat-Oval Elbows: Fabricate gored elbows unless space restrictions require mitered elbows.
6. Die-Formed Elbows for Sizes through 8-inches in Diameter and Pressures 0.040-inch thick with two-piece welded construction.
7. Round Gored-Elbow Metal Thickness: Same as non-elbow fittings specified above.
8. Pleated Elbows for Sizes through 14-inches in Diameter and Pressures through 10-inch wg (2500 Pa): 0.022-inch.
9. Not acceptable:
 - a. Corrugated or flexible metal duct.
 - b. Adjustable elbows.

2.3 LAUNDRY CLOTHES DRYER VENT

- A. Aluminum sheet metal, minimum 24 gauge. Substantially airtight duct except for openings required for operation and maintenance. Duct to have smooth interior surface. Do not assemble with sheet metal screens or other devices that extend into the airstream.

2.4 INSULATED FLEXIBLE DUCT

- A. Construction: Standard factory fabricated product. Inner wall: Impervious vinyl or chlorinated polyethylene, permanently bonded to a vinyl or zinc-coated spring steel helix.

- B. Insulation: Fiberglass blanket insulation covered by an outer wall of vinyl or fiberglass-reinforced metalized vapor barrier.
- C. Listing: UL 181 listed Class 1 flexible air duct material. Overall thermal transmission: No more than 0.25 BTU/in or hr/sq. degrees F at 75 degrees F differential, per ASTM C335.
- D. Vapor transmission value no more than 0.10 perm, per ASTM E96
- E. Pressure Rating: 4-inch wg positive pressure and 1-inch wg negative pressure.
- F. Performance Air Friction Correction Factor: 1.3 maximum at 95 percent extension. Working air velocity: Minimum 2000 FPM.
- G. Flame Spread Rating: No more than 25.
- H. Smoke Development Rating: No more than 50 as tested per ASTM E84.
- I. Insertion Loss: Minimum attenuation of 29 DB for 10-foot straight length at 8-inch diameter at 500 Hz.

2.5 DRAIN PANS

- A. Primary Drain Pans: Stainless Steel, Fabricated in accordance with ASTM A167 and A480.
- B. Secondary Drain Pans: Galvanized Steel: Hot-dipped galvanized steel sheet, ASTM A 653/A 653M FS Type B, with G90/Z275 coating.

2.6 DUCTWORK JOINT SEALERS AND SEALANTS

- A. Joint Sealers and Sealants: Non-hardening, water resistant, mildew and mold resistant.
- B. Low Emitting Materials Requirement: Adhesives, sealants and sealant primers must comply with South Coast Air Quality Management District (SCAQMD) Rule #1168.
- C. Type: Heavy mastic or liquid used alone or with tape, suitable for joint configuration and compatible with substrates, and recommended by manufacturer for pressure and leakage class of ducts.
- D. Surface Burning Characteristics: Flame spread of zero, smoke developed of zero, when tested in accordance with ASTM E 84.
- E. Water Based Sealant for Brush-On Application: Flexible, adhesive sealant, resistant to UV light, UL-181A, and UL-181-B listed, complying with NFPA requirements for Class 1 ducts. Min. 69 percent solids, nonflammable. Hardcast Versa-Grip 181; Childers CP-146; Foster 32-19 for SMACNA 1/2, 1, 2, 3, 4, 6, and 10-inch WG duct classes, and SMACNA Seal Class A, B, or C.
- F. Flanged Joint Mastic: One-part, acid-curing, silicone, elastomeric joint sealant complying with ASTM C920, Type S, Grade NS, Class 25, Use O.

- G. Flange Gaskets: Butyl rubber or EPDM polymer with polyisobutylene plasticizer.
- H. Polyurethane Sealant: General-purpose, exterior use, non-brittle sealant for gunned application. Vulkem 616 or equal.

PART 3 - EXECUTION

3.1 GENERAL INSTALLATION REQUIREMENTS

- A. General: Use the following pressure seal, and leakage class(es) in design of ductwork specified in this section unless otherwise noted on Drawings.

SYSTEM	PRESSURE CLASS (Inches of Water)	SEAL CLASS	LEAKAGE CLASS ROUND DUCTS	LEAKAGE CLASS RECTANGULAR DUCTS
Medium pressure supply (fan to terminal unit)	0.5-inch higher than air handlers discharge pressure (min 4-inch pressure class).	A	3	6
Low pressure (downstream of terminal unit)	+ 1-inch	A	3	6
Return main (>24-inch)	0.5-inch more negative than return/exhaust fan pressure or -2-inch pressure class, whichever is more negative.	A	3	6
Return branch (<24-inch)	0.5-inch more negative than return/exhaust fan pressure or -2-inch pressure class, whichever is more negative.	A	3	6
General exhaust	0.5-inch more negative than return/exhaust fan pressure or -2-inch pressure class, whichever is more negative.	A	3	6
Kitchen grease exhaust	-6-inch	N/A	N/A	N/A
Lab medium pressure exhaust (lab valve/terminal unit to fan)	-6-inch	A	3	6
Lab low pressure exhaust (upstream of lab valve/terminal unit)	-1-inch	A	3	6

Hazardous exhaust	-6-inch	A	3	6
Cryogen relief vent	+10-inch	N/A	N/A	N/A

B. Ductwork Installation:

1. General: Install entire duct system in accordance with drawings, Specifications, and latest issues of local Mechanical Code, NFPA 90A, and SMACNA Duct Construction Manual. At Contractor's option, rectangular ductwork may be resized to maintain an equivalent air velocity and friction rate, while maintaining a maximum aspect ratio of 3. Remove markings and tagging from ductwork exterior surface in mechanical rooms and other locations where ductwork is exposed.
2. The duct layout shown on the Contract Drawings is diagrammatic in nature. Coordinate the ductwork routing and layout, and make alterations to the ductwork routing and layout to eliminate physical interferences. Where deviations in the ductwork routing as shown in the Contract Drawings are required, alterations may be made so as not to compromise the air flow, pressure drop, and sound characteristics of the duct fitting or duct run as shown on the Contract Drawings. In the event Architect determines that the installed ductwork is inconsistent with the above mentioned criteria, remove and replace at no additional cost to the Owner.
3. Install ducts with fewest possible joints.
4. Install fabricated fittings for changes in directions, size, shape, and for connections.
5. Install couplings tight to duct wall surface with a minimum of projections into duct. Secure couplings with sheet metal screws. Install screws at intervals of 12-inches, with a minimum of 3 screws in each coupling.
6. Install ducts, unless otherwise indicated, vertically and horizontally and parallel and perpendicular to building lines; avoid diagonal runs.
7. Install ducts close to walls, overhead construction, columns, and other structural and permanent enclosure elements of building.
8. Install ducts with a clearance of 1-inch, plus allowance for insulation thickness. Allow for easy removal of ceiling tile.
9. Conceal ducts from view in finished spaces. Do not encase horizontal runs in solid partitions unless specifically indicated.
10. Coordinate layout with suspended ceiling, air duct accessories, lighting layouts, and similar finish work.
11. Electrical and IT Equipment Spaces: route ducts to avoid passing through transformer vaults, electrical equipment spaces, IDF/MPOE rooms, and enclosures.
12. Boiler Rooms and Refrigeration Machinery Rooms: Only route ducts serving these rooms through these rooms.
13. Non-Fire-Rated Partition Penetrations: Where ducts pass through interior partitions and exterior walls and are exposed to view, conceal spaces between construction openings and ducts or duct insulation with sheet metal flanges of same metal thickness as ducts. Overlap openings on 4 sides by at least 1-1/2-inches.
14. Fire- and Smoke-Rated Partition Penetrations: Where ducts pass through interior partitions and exterior walls, install appropriately rated fire, smoke or combination fire and smoke dampers as governed by Building Code and AHJ, including sleeves, and firestopping sealant.
15. Install ducts with hangers and braces designed to withstand, without damage to equipment, seismic force required by applicable building codes. Reference SMACNA's

Seismic Restraint Manual: Guidelines for Mechanical Systems, Mason Seismic Restraint and Support Systems.

16. Protect duct interiors from the elements and foreign materials until building is enclosed. Follow SMACNA's Duct Cleanliness for New Construction Advanced Level.
17. Paint interiors of metal ducts, that do not have duct liner, for 24-inches upstream of registers and grilles. Apply one coat of flat, black, latex finish coat over a compatible duct material.
18. Install ductwork in the location and manner shown and detailed. Review deviations required by job conditions with Architect prior to any fabrication. Provide fittings for construction per SMACNA.
19. Install flexible ductwork to limit sag between support hangers to 1/2-inch per foot of spacing support.

C. Flanged Take-Offs:

1. Install at branch takeoffs to outlets using round or flex duct.
2. Flanged take-offs secured with minimum 8-inch screw spacing (three screws minimum).
3. Provide ductwork taps and branches off of main ducts at 45 degrees whether shown on Drawings or not (drawings are diagrammatic).

D. Cleaning:

1. Clean duct systems with high power vacuum machines. Protect equipment that could be harmed by excessive dirt with filters, or bypass during cleaning. Provide adequate access into ductwork for cleaning purposes.
2. Grille and Exposed Duct Cleaning:
 - a. After completion of ductwork installation, operate each fan system (excluding exhaust fans) for a minimum of 30 minutes prior to installation of ceiling grilles and diffusers. After grilles and diffusers are installed, clean out accumulation of particles from grilles and diffusers prior to acceptance.
 - b. Clean exterior surface of ducts exposed to public view of chalk, pencil and pen marks, labels, sizing tags, dirt, dust, etc., so that upon completion of installation, ducts are left in clean and unblemished manufactured conditions.
 - c. Exposed duct and grilles to remain free of dust entrained streaks due to leakage at joints and grille connections during warranty period. Clean leaks, seal and refinish to match existing if visible streaks develop.

3.2 DUCTWORK, JOINTS AND FITTINGS INSTALLATION

A. Duct Materials - Applied Locations:

1. General: Use the following materials in design of ductwork specified in this Section unless otherwise noted on the Drawings.

Location or Application	Material
Supply, Return, Transfer, and Exhaust - Low Pressure (downstream of terminal units)	Single Wall, Galvanized Steel
Supply, Return, and Exhaust - Medium Pressure (upstream of terminal units)	Single Wall, Galvanized Steel
General Exhaust Branch Serving Air Inlet in Shower Room or Toilet Room with Shower	Single Wall, Aluminum or Type 304 Stainless Steel
Supply, Return, Exhaust serving Natatorium, Pool, or Spa Area	Single Wall, Aluminum or Type 304 Stainless Steel

Fume Hood Exhaust	Single Wall, Type 316 Stainless Steel
Ductwork for the First 15-feet Downstream of Humidifier	Single Wall, Type 316 Stainless Steel

B. Ductwork Installation:

1. Fabricate radius elbows with centerline radius not less than 1-1/2 duct diameters.
2. Do not install duct size transition pitch angles which exceed 30 degrees for reductions in duct size in the direction of airflow, and 15 degrees for expansions in duct size in the direction of airflow.
3. Install fixed turning vanes in square throat rectangular elbows and in tees.
4. Fabricate duct turns with the inside (smallest) radius at least equal to the duct width (supply ducts) and 1.5 times radius (return and exhaust ducts). Where necessary, square elbows may be used, with maximum available inside radius and with fixed turning vanes. In healthcare settings such as hospitals and medical office buildings, square elbows and turning vanes allowed on supply ductwork only.

3.3 LAUNDRY CLOTHES DRYER VENT

- A. Install vent in accordance with manufacturer's instructions and recommendations.

3.4 INSULATED FLEXIBLE DUCT INSTALLATION

- A. Provide sheet metal plenum or rigid elbow and connect to diffusers and grilles with ductwork connections. Refer to Drawings for more information. Provide straight section of flexible duct with minimum length of 2-feet and maximum length of 5-feet and connect to sheet metal plenums and rigid elbows connected to diffusers and grilles, unless noted otherwise.
1. Provide round neck grilles/diffusers or square-to-round transitions. Flexible duct connections directly to diffuser and grilles is not allowed.
 2. Flexible duct allowed in concealed spaces above lay-in ceilings only.

3.5 DRAIN PANS INSTALLATION

- A. Install where shown on Drawings. Drain provided by Division 22, Plumbing. Provide drain (sized per code) connection from each drain pan and pipe to nearest floor drain through trap and 10-inch air gap. Drain pans over 6-feet in length require drain connections from both ends. Pitch drain pans in direction of air flow and to drain. Support secondary drain pan independently from equipment.

3.6 DUCTWORK JOINT SEALERS AND SEALANTS INSTALLATION

- A. Joints and Seam Joint Sealing:
1. Seal duct seams and joints according to SMACNA's HVAC Duct Construction Standards - Metal and Flexible, for duct pressure class indicated.
 2. Seal transverse joints, longitudinal seams and duct wall penetrations including screw, fastener, pipe, rod, and wire.
 3. Seal ducts before external insulation is applied.
 4. Tape joints of PVC coated metal ductwork with PVC tape.
 5. Fasteners such as sheet-metal screws, machine screws or rivets to be cadmium plated.

6. Rectangular Ductwork: Where intermediate joint reinforcement is required for duct of negative pressure class, pre-drill stiffening flange and provide fastener maximum 8-inches on center. Where retaining flanges are welded to duct wall, paint welds with zinc coating.
7. Single Wall Round Ductwork: Joint to incorporate beaded slip collar with minimum #8 sheet metal screws 8-inches on center. Seal ductwork as specified in this Section.
8. Seal joints and seams. Apply sealant to make end connectors before insertion, and afterward to cover entire joint and sheet metal screws.
9. Double Wall Round Ductwork: Joint to incorporate beaded slip collar or flanged connection, with minimum #8 sheet metal screws 8-inches on center. Seal ductwork as specified in this Section.
10. Duct sizes indicated are inside clear dimensions. For lined ducts, maintain sizes inside lining.
11. Provide openings in ductwork where required to accommodate thermometers and control devices. Provide pitot tube openings where required for testing of systems, complete with metal can with spring device or screw to ensure against air leakage. Where openings are provided in insulated ductwork, install insulation material inside a metal ring.
12. Locate ducts with sufficient space around equipment to allow normal operating and maintenance activities as well as Code required clearances.

END OF SECTION

SECTION 23 3300 - AIR DUCT ACCESSORIES

PART 1 - GENERAL

1.1 SUMMARY

- A. Work Included:
1. Sheet Metal Materials
 2. Backdraft Dampers
 3. Dampers
 4. Concealed Damper Hardware
 5. Access Doors
 6. Duct Test Holes
 7. Dynamic Fire Dampers
 8. Ceiling Fire Dampers
 9. Smoke Dampers
 10. Combination Fire and Smoke Dampers
 11. Turning Vanes
 12. Flexible Connectors

1.2 RELATED SECTIONS

- A. Contents of Division 23, HVAC and Division 01, General Requirements apply to this Section.

1.3 REFERENCES AND STANDARDS

- A. References and Standards as required by Section 23 00 00, HVAC Basic Requirements and Division 01, General Requirements.

1.4 SUBMITTALS

- A. Submittals as required by Section 23 00 00, HVAC Basic Requirements and Division 01, General Requirements.
- B. In addition, provide:
1. Manufacturer's catalog data and fabrication/installation drawings for each factory fabricated duct accessory. Include leakage, pressure drop and maximum back pressure data.
 2. Shop Drawings: Indicate air duct accessories.
 3. Manufacturer's installation instructions: Provide instructions for each factory fabricated duct accessory.
 4. Maintenance Materials: Furnish the following for Owner's use in maintenance of project.
 - a. See Division 01, General Requirements, Product Requirements for additional provisions.
 - b. Extra Fusible Links: One of each type and size.

1.5 QUALITY ASSURANCE

- A. Quality assurance as required by Section 23 00 00, HVAC Basic Requirements and Division 01, General Requirements.

- B. In addition, meet the following:
1. Manufacturer Qualifications: Company specializing in manufacturing the type of products specified in this Section, with minimum five years of documented experience.
 2. Products Requiring Electrical Connection: Listed and classified by Underwriters Laboratories Inc. as suitable for the purpose specified and indicated.
 3. AMCA 500 - Test Methods for Louvers, Dampers and Shutters.
 4. AMCA 511 - Certified Ratings Program for Air Control Devices.
 5. AMCA 611, latest edition - Certified Ratings Program - Product Rating Manual for Airflow Measurement Stations.
 6. AMCA 610, latest edition - Laboratory Methods of Testing Airflow Measurement Stations for Performance Rating.
 7. NFPA 90A - Installation of Air Conditioning and Ventilating Systems.
 8. NFPA 92A - Smoke-Control Systems.
 9. NFPA 92B - Smoke Control Systems in Atria, Covered Malls and Large Areas.
 10. NFPA 101 - Life Safety Code.
 11. UL 555 - Standard for Safety; Fire Dampers.
 12. UL 555S - Standard for Safety; Leakage Rated Dampers for Use in Smoke Control Systems.

1.6 WARRANTY

- A. Warranty of materials and workmanship as required by Section 23 00 00, HVAC Basic Requirements and Division 01, General Requirements.

PART 2 - PRODUCTS

2.1 MANUFACTURERS

- A. Backdraft Dampers:
1. Air Balance
 2. Cesco
 3. Greenheck
 4. Nailor
 5. Ruskin
- B. Dampers:
1. Air Balance
 2. Cesco
 3. Greenheck
 4. Nailor
 5. Ruskin
- C. Concealed Damper Hardware, Cable System:
1. Young Regulator Company
- D. Access Doors:
1. Ductmate
 2. Cesco
 3. Ruskin

4. Nailor
 5. Outdoor Installation: Karp MX insulated exterior access door.
- E. Duct Test Holes:
1. Ventlok
- F. Dynamic Fire Dampers:
1. Ruskin
 2. Greenheck
 3. Nailor
- G. Ceiling Fire Dampers:
1. Ruskin
 2. Greenheck
 3. Nailor
- H. Smoke Dampers:
1. Ruskin
 2. Greenheck
 3. Nailor
- I. Combination Fire and Smoke Dampers:
1. Ruskin
 2. Greenheck
 3. Nailor
 4. Pottorff
- J. Turning Vanes:
1. Aerodyne
 2. Ductmate Industries
 3. Duro Dyne Corp
 4. Metalaire Inc.
- K. Flexible Connectors:
1. Duro Dyne Corp.
 2. Ventfabrics Inc.
 3. Ductmate Industries
 4. Hardcast
- 2.2 SHEET METAL MATERIALS
- A. Comply with SMACNA's "HVAC Duct Construction Standards--Metal and Flexible" for acceptable materials, material thicknesses, and duct construction methods, unless otherwise indicated.
- B. Galvanized Sheet Steel: Lock-forming quality; complying with ASTM A 653/A 653M. Galvanizing: 1-1/4 ounces per square foot total both sides; ducts to have mill-phosphatized finish for surfaces exposed to view.
- C. Stainless Steel: ASTM A 480/A 480M.

- D. Aluminum Sheets: ASTM B 209 (ASTM B 209M), alloy 3003, temper H14; with mill finish for concealed ducts and standard, 1-side bright finish for exposed ducts.
- E. Extruded Aluminum: ASTM B 221 (ASTM B 221M), alloy 6063, temper T6.
- F. Reinforcement Shapes and Plates: Galvanized-steel reinforcement where installed on galvanized sheet metal ducts; compatible materials for aluminum and stainless-steel ducts.
- G. Tie Rods: Galvanized steel, 1/4-inch minimum diameter for lengths 36-inches or less; 3/8-inch minimum diameter for lengths longer than 36-inches.

2.3 BACKDRAFT DAMPERS

- A. Basis-of-Design: Ruskin CB D6.
- B. Description: Multiple-blade gravity balanced with center pivoted blades with sealed edges, assembled in rattle free manner with 90-degree stop, adjustment device to permit setting for varying differential static pressure.
- C. Frame: 0.125-inch thick 6063-T5 extruded aluminum channel with galvanized steel braces at mitered corners. Provide mounting flange.
- D. Blades: Single piece, overlap frame, parallel action, horizontal orientation, minimum 0.07-inch 6063-T5 extruded aluminum material, maximum 6-inch width.
- E. Bearings: Corrosion-resistant synthetic, formed as single piece with axles.
- F. Blade Seals: Extruded vinyl, mechanically attached to blade edge.
- G. Blade Axles: Corrosion-resistant, synthetic formed as single piece with bearings, locked to blade.
- H. Tie Bars and Brackets: Galvanized steel.
- I. Return Spring: Adjustable tension.
- J. Damper Capacity:
 - 1. Closed Position: Maximum back pressure of 16-inches water gauge.
 - 2. Open Position: Maximum air velocity of 2,500-feet per minute.
- K. Counterbalances: Adjustable zinc plated steel weights mechanically attached to blade. Must be capable of operating over wide range of pressures.
- L. Finish: Mill aluminum.
- M. Temperature Rating: -40 degrees F to 200 degrees F.
- N. Operation of Blade:
 - 1. Start to Open: 0.01-inch wg
 - 2. Fully Open: 0.05-inch.

- O. Pressure Drop: Maximum 0.15-inch wg at 1,500-feet per minute through 24-inch by 24-inch damper.
- P. Factory Sleeve: Minimum 20 gauge thickness, 12-inches in length.
- Q. Screen: At outdoor intake or discharge. 1/4-inch aluminum.

2.4 DAMPERS

- A. Basis-of-Design: Ruskin MD 35.
- B. General Description: Factory fabricated, with required hardware and accessories. Stiffen damper blades for stability. Include locking device to hold single-blade dampers in a fixed position without vibration. Close duct penetrations for damper components to seal duct consistent with pressure class.
 - 1. Pressure Classes of 3-Inch wg (750 Pa) or Higher: End bearings or other seals for ducts with axles full length of damper blades and bearings at both ends of operating shaft.
- C. Rectangular Volume Dampers: Multiple- or single-blade, parallel- or opposed-blade design with linkage concealed in frame and suitable for horizontal or vertical applications.
 - 1. Steel Frames: Hat-shaped, galvanized sheet steel channels, minimum 16 gauge thick, with mitered and welded corners; frames with flanges where indicated for attaching to walls and flangeless frames where indicated for installing in ducts.
 - a. Roll-Formed Steel Blades: 16 gauge thick, galvanized sheet steel.
 - b. Aluminum Frames: Hat-shaped, 10 gauge thick, aluminum sheet channels; frames with flanges where indicated for attaching to walls; and flangeless frames where indicated for installing in ducts.
 - c. Roll-Formed Aluminum Blades: 10 gauge thick aluminum sheet.
 - d. Extruded-Aluminum Blades: 16 gauge thick extruded aluminum.
 - e. Blade Axles: Minimum 1/2-inch diameter, plated steel, hex shaped, mechanically attached to blade.
 - f. Bearings: Molded synthetic sleeve, turning in extruded hole in frame.
 - g. Tie Bars and Brackets: Galvanized steel.
 - h. Mill galvanized.
 - i. Capacity:
 - 1) Closed Position: Maximum pressure of 3-inches wg.
 - 2) Open Position: Maximum air velocity of 1,500-feet per minute across 24-inch by 24-inch damper.
- D. Round Volume Dampers: Single-blade suitable for horizontal or vertical applications.
 - 1. Steel Frames: Galvanized, roll formed, minimum of 20 gauge thick with beads at each end.
 - 2. Blades: Minimum 20 gauge thick, galvanized sheet steel, round, single-piece.
 - 3. Aluminum Frames: Minimum 10 gauge thick aluminum sheet.
 - 4. Aluminum Blades: Minimum 10 gauge thick aluminum sheet.
 - 5. Extruded-Aluminum Blades: Minimum 16 gauge thick extruded aluminum.
 - 6. Blade Axles: Minimum 3/8-inch square, plated steel, mechanically attached to blade.
 - 7. Bearings: Molded synthetic sleeve, turning in hole in frame.
 - 8. Finish: Mill galvanized.

9. Capacity:
 - a. Closed Position: Maximum pressure of 3-inches wg
 - b. Open Position: Maximum air velocity of 1,500-feet per minute.
 10. Leakage: Maximum 40 cfm at 1-inch wg for 20-inches diameter damper.
 11. Pressure Drop: Maximum 0.02-inch wg at 1,500-feet per minute through 20-inch diameter dampers.
- E. Jackshaft: 1-inch diameter, galvanized-steel pipe rotating within pipe-bearing assembly mounted on supports at each mullion and at each end of multiple-damper assemblies.
1. Length and Number of Mountings: Appropriate to connect linkage of each damper in multiple-damper assembly.
 2. Damper Hardware: Zinc-plated, die-cast core with dial and handle made of 3/32-inch thick zinc-plated steel, and a 3/4-inch hexagon locking nut. Include center hole to suit damper operating-rod size. Include 2-inch elevated platform for insulated duct mounting.

2.5 CONCEALED DAMPER HARDWARE

- A. Concealed Damper Hardware: For dampers above non-removable ceilings (gyp, plaster, decorative, etc.) where access panels have not been shown on Architectural drawings or in locations where dampers are more than 2-feet above the ceiling, provide:
1. Concealed Damper Regulator: Young Regulator Company Model 315 or approved equivalent.
 2. Cable System: Young Regulator Company or approved equivalent.
 3. Controller: Young Regulator Company 270-275 or approved equivalent.
 4. Control wrenches, wire stops, casing nuts, and stainless steel wire.
 5. Paint cover plate to match ceiling color or as directed by Architect.

2.6 ACCESS DOORS

- A. Duct Pressure Class 2-inch WC and Greater: Sandwich-type design with threaded locking bolt assembly. Closed cell neoprene gasket permanently bonded to inside panel. Zinc-coated steel wing nuts or polypropylene molded knobs with threaded metal inserts - zinc coated bolts sealed to inner panel.
- B. Duct Pressure Class 1-1/2-inch WC and Less: Galvanized steel assembly incorporating frame, door, hinges, and latch(es). Frame tabbed for attachment to duct panel. Double wall door panel with 1-inch insulation. Open cell neoprene gasket attached to frame. Cam latches for tight closure.
- C. Plenum Doors: Extruded aluminum frames with extruded santoprene seals. Double-wall 20 gauge galvanized steel door panel with fiberglass insulation.
- D. Size: Maximum size available to fit rectangular duct panel dimension or round duct diameter. Plenum doors minimum 2-feet wide by 4-feet high.
- E. For outdoor installation, only provide waterproof access doors installed vertically.

2.7 DUCT TEST HOLES

- A. Temporary Test Holes: Cast iron or cast aluminum to suit duct material, including screw cap and gasket. Size to allow insertion of pitot tube and other testing instruments and of length to suit duct insulation thickness.
- B. Permanent Test Holes: Factory fabricated, air tight flanged fittings with screw cap. Provide extended neck fittings to clear insulation.

2.8 DYNAMIC FIRE DAMPERS

- A. Basis-of Design:
 - 1. Ruskin Model DIBD2, 1-1/2 hour rated
 - 2. Ruskin Model DIBD23, 3 hour rated
- B. Ratings:
 - 1. Fire Resistance: UL 555 classified and provide fire dampers with UL label for fire rating as appropriate for wall rating and in conformance with NFPA 90A.
 - 2. Dynamic Closure Rating: Dampers classified for dynamic closure to 2000-feet per minute and 4-inches wg static pressure.
- C. Construction:
 - 1. Frame: Roll formed, galvanized steel channel.
 - 2. Sleeves: Damper to be supplied as a single assembly with an integral factory sleeve.
 - 3. Retaining Angles: Damper to be supplied with factory retaining angles sized to provide installation overlap in accordance with manufacturer's UL listing.
 - 4. Blades: Galvanized curtain type.
 - 5. Closure Springs: Type 301 stainless steel, constant force or spring clip type.
 - 6. Temperature Release Device: 165 degrees F, 212 degrees F, or 285 degrees F.
 - 7. Mounting: Vertical or Horizontal based on application.
 - 8. Finish: Mill galvanized for installation in galvanized sheet metal and Type 304 stainless steel for installation in stainless steel ductwork.
- D. Indicator Switches: Not Required.
- E. Factory mounting angles and breakaway connections
- F. Factory Tests: Factory cycle damper to assure proper operation.

2.9 CEILING FIRE DAMPERS

- A. Basis-of-Design:
 - 1. Ruskin Model CFD(R)2, 1-1/2 hour rated up to 324 square inches.
 - 2. Ruskin Model CFD(R)3, 3 hour rated up to 324 square inches.
 - 3. Ruskin Model CFD (R)4, 3 hour rated, larger than 324 square inches and smaller than 576 square inches.
 - 4. Ruskin Model CFD(R)5, 3 hour rated for lay-in ceiling diffusers.
 - 5. Ruskin Model CFD7T, Wood truss floor/ceiling and roof/ceiling application.

B. Fabrication:

1. Fire Rating: UL 555C classified and provide fire dampers with UL label for fire rating as appropriate for ceiling rating, opening size, ceiling construction, and in conformance with NFPA 90A.
2. Air Flow Rating: UL approved for dual directional air flow.
3. Frame: 20 gauge galvanized steel with roll formed ridge for blade stop.
4. Blades:
 - a. Style: Two-piece, single-thickness with blade insulation, hinged in center, and held open with fusible link.
 - b. Action: Butterfly.
 - c. Orientation: Horizontal.
 - d. Material: Minimum 20 gauge galvanized steel.
5. Hinge: Spring stainless steel, mechanically attached to blades.
6. Mounting: Horizontal.
7. Temperature Release Device: 165 degrees F or 212 degrees F.
8. Finish: Mill galvanized for installation in galvanized sheet metal and Type 304 stainless steel for installation in stainless steel ductwork.
9. Assembly: Factory assemble damper and accessories and furnish as a single unit conforming to UL 555C.

C. Performance Data:

1. Pressure Drop: Maximum 0.1-inch wg at 500-feet per minute across 18- by 18-inch damper.

D. Fusible Volume Adjust:

1. UL classified.
2. Permits adjustment of damper blades to balance airflow.
3. Closes damper in fire conditions.

E. Extended Frame.

F. Factory Tests: Factory cycle damper assembly to assure proper operation.

2.10 SMOKE DAMPERS

A. Basis-of-Design:

1. Ruskin Model SDRS25, Leakage Class I, round ductwork up to 24-inch diameter.
2. Ruskin Model SD60, Leakage Class I, for rectangular ducts or round ductwork larger than 24-inch diameter. Provide duct transition between round and rectangular connections.
3. - SS, Stainless steel models for use in stainless steel ductwork.
4. - M, Modulating.

B. Ratings:

1. Smoke Rating: Leakage Class Smoke Damper in accordance with UL555S. Leakage class at 4-inch wg
2. Elevated Temperature Rating: 250 degrees F or 350 degrees F.
3. Air Flow Rating: 2000-feet per minute.
 - a. Differential Pressure Rating: 4-inch wg.

- C. Construction:
1. Frame: 16 gauge roll formed, galvanized steel hat-shaped channel, reinforced at corners. Structurally equivalent to 13 gauge U-channel type frame.
 2. Blades (Leakage Class II):
 - a. Style: Single skin with three longitudinal grooves.
 - b. Action: Opposed.
 - c. Material: Minimum 16 gauge galvanized steel.
 - d. Width: Maximum 6-inches.
 3. Blades (Leakage Class I):
 - a. Style: True airfoil-shaped, single piece, double skin.
 - b. Action: Opposed.
 - c. Material: Minimum 14 gauge equivalent thickness, galvanized steel.
 - d. Width: Maximum 6-inches.
 4. Bearings: Self-lubricating stainless steel sleeve type, turning in extruded hole in frame.
 5. Seals:
 - a. Blade: Inflatable silicone fiberglass material to maintain smoke leakage rating to a minimum of 450 degrees F and galvanized steel for flame seal to 1,900 degrees F. Mechanically attached to blade edge (glue-on or grip type seals are not acceptable).
 - b. Jamb: Stainless steel, flexible metal compression type.
 6. Linkage: Concealed in frame.
 7. Axles: Minimum 1/2-inch diameter plated steel, hex-shaped, mechanically attached to blade.
 8. Mounting: Vertical or Horizontal, based on application.
 9. Actuator: Electric, two-position, fail close.
 10. Finish: Mill galvanized.
- D. Factory mounting angles.
- E. Factory Sleeve:
1. Minimum 20 gauge thickness.
 - a. Silicone caulk factory applied to sleeve at damper frame to comply with leakage rating requirements.
- F. Factory Breakaway Connections.
- G. Factory Tests: Factory cycle damper and actuator assembly to assure proper operation.

2.11 COMBINATION FIRE AND SMOKE DAMPERS

- A. Basis-of-Design:
1. Ruskin Model FSD25R, Leakage Class 1, 1-1/2 hour rated, for round ductwork up to 24-inch diameter.
 2. Ruskin Model FSD60, Leakage Class I, 1-1/2 hour rated, for rectangular ducts or round ductwork larger than 24-inch diameter. Provide duct transition between round and rectangular connections. Pressure drop of a 24-inch by 24-inch damper at 1,000 and 2,000 fpm face velocity shall not exceed 0.03 and 0.16 in-wc., respectively.
 3. - C, for use in tunnel corridor applications.
 4. - FA, front access models.

5. - SS, Stainless Steel Models for use in stainless steel ductwork.
6. - M, modulating.
7. - VALR, for use in validated systems.
8. - XP, for use in explosion proof applications.
9. - 3, for use in 3-hour rated assemblies.

B. Ratings:

1. Fire Resistance: UL 555 classified and provide combination fire and smoke dampers with UL label for fire rating as appropriate for construction rating and in conformance with NFPA 90A.
2. Smoke Rating: Leakage Class Smoke Damper in accordance with UL555S. Leakage class at 4-inch wg
3. Elevated Temperature Rating: 250 degrees F or 350 degrees F.
4. Air Flow Rating: 2,000 feet per minute.
5. Differential Pressure Rating: 4-inch wg.

C. Construction:

1. Frame: 16 gauge roll formed, galvanized steel hat-shaped channel, reinforced at corners. Structurally equivalent to 13 gauge U-channel type frame.
2. Blades (Leakage Class II):
 - a. Style: Single skin with 3 longitudinal grooves.
 - b. Action: Opposed.
 - c. Material: Minimum 16 gauge galvanized steel.
 - d. Width: Maximum 6-inches.
3. Blades (Leakage Class I):
 - a. Style: True airfoil-shaped, single piece, double skin.
 - b. Action: Opposed.
 - c. Material: Minimum 14 gauge equivalent thickness, galvanized steel.
 - d. Width: Maximum 6-inches.
4. Bearings: Self-lubricating stainless steel sleeve type, turning in extruded hole in frame.
5. Seals:
 - a. Blade: Inflatable silicone fiberglass material to maintain smoke leakage rating to a minimum of 450 degrees F and galvanized steel for flame seal to 1,900 degrees F. Mechanically attached to blade edge (glue-on or grip type seals are not acceptable).
 - b. Jamb: Stainless steel, flexible metal compression type.
6. Linkage: Concealed in frame.
7. Axles: Minimum 1/2-inch diameter plated steel, hex-shaped, mechanically attached to blade.
8. Mounting: Vertical or Horizontal, based on application.
9. Temperature Release Device: Heat actuated, Quick Detect.
 - a. Close (in a controlled manner) and lock damper during test, smoke detection, power failure, or fire conditions through actuator closure spring. Actuator, at no time, to disengage from damper blades.
 - b. Allow damper to be automatically and remotely reset after test or power failure conditions. After exposure to high temperature or fire, inspect damper before reset to ensure proper operation.
 - c. Controlled closing and locking of damper in 7 to 15 seconds to allow duct pressure to equalize. Instantaneous closure is not acceptable.

10. Release Temperature: 165 degrees F, 212 degrees F, 250 degrees F, 285 degrees F, or 350 degrees F.
11. Actuator: Electric, two-position, fail close.
12. Finish: Mill galvanized for installation in galvanized sheet metal and Type 304 stainless steel for installation in stainless steel ductwork.
13. Firestat:
 - a. UL classified dual temperature device allows the damper to be re-opened after initial closure from high heat.
 - b. Electrically and mechanically locks damper in closed position when duct temperatures exceed 165 degrees F or 212 degrees F.
 - c. Allow damper to remain operable through a high limit temperature sensor for smoke management purposes while temperature is below 250 degrees F or 350 degrees F.
 - d. Replaces EFL or PFL Ruskin Controlled Closure heat actuated temperature release devices on standard dampers.
 - e. Blade position indicator switches: Two position indicator switches linked directly to damper blade in order to allow remote indication of damper blade position. Provide separate switches for indication of closed and open position.
14. Indicator or Auxiliary Switch Packages: Not required.

D. Factory mounting angles.

E. Factory Sleeve:

1. Minimum 20 gauge thickness.
 - a. Silicone caulk factory applied to sleeve at damper frame to comply with leakage rating requirements.
 - b. Factory breakaway connections.
 - c. Factory Tests: Factory cycle damper and actuator assembly to assure proper operation.

2.12 TURNING VANES

- A. Fabricate to comply with SMACNA's "HVAC Duct Construction Standards--Metal and Flexible" for vanes and vane runners. Vane runners to automatically align vanes.
- B. Manufactured Turning Vanes: For medium pressure ductwork, ductwork upstream of terminal units, and in ductwork with equal inlet width and height dimensions and outlet width and height dimension, provide double thickness airfoil turning vanes. Low pressure ductwork and ductwork downstream of terminal units use either single thickness or double thickness turning vanes. For mitered rectangular elbows with changes in size from inlet to outlet, only use single thickness turning vanes. Use 2-inch radius vanes spaced on centers of 1.5-inches for single thickness. Use 2-inch radius vanes spaced on centers of 2.125-inches for double thickness.
- C. Acoustic Turning Vanes: Fabricate airfoil-shaped aluminum extrusions with perforated faces and fibrous-glass fill.

2.13 FLEXIBLE CONNECTORS

- A. General Description: Flame-retardant or noncombustible fabrics, coatings, and adhesives complying with UL 181, Class 1.

- B. Metal-Edged Connectors: Factory fabricated with a fabric strip 4-inches wide attached to two strips of 2-3/4-inch wide, 0.028-inch thick, galvanized sheet steel or 0.032-inch thick aluminum sheets. Select metal compatible with ducts.
- C. Provide a spring and bracket assembly to reinforce the fabric with sufficient tension to prevent connector collapse under negative or positive pressure. Number and positioning of spring-link fixture to be determined by the manufacturer to maintain straight axis and without kinks between two sections of duct, or between duct and the moving element. Hardcast Spring-Link SL-200, or equal.
- D. Indoor System, Flexible Connector Fabric (FC-I): Glass fabric double coated with neoprene.
 - 1. Minimum Weight: 26 ounces per square yard.
 - 2. Tensile Strength: 300 pounds of force per inch in the warp and 225 pounds of force per inch in the filling.
 - 3. Service Temperature: -40 degrees F to 200 degrees F.
- E. Outdoor System, Flexible Connector Fabric (FC-O): Glass fabric double coated with weatherproof, synthetic rubber resistant to UV rays and ozone.
 - 1. Minimum Weight: 30 ounces per square yard.
 - 2. Tensile Strength: 475 pounds of force per inch in the warp and 375 pounds of force per inch in the filling.
 - 3. Service Temperature: -40 degrees F to 200 degrees F.
- F. High-Temperature System, Flexible Connectors (FC-HT): Glass fabric coated with silicone rubber.
 - 1. Minimum Weight: 16 ounces per square yard.
 - 2. Tensile Strength: 285 pounds of force per inch in the warp and 185 pounds of force per inch in the filling.
 - 3. Service Temperature: -67 degrees F to 500 degrees F.
- G. High-Corrosive-Environment System, Flexible Connectors (FC-HC): Glass fabric with chemical-resistant coating.
 - 1. Minimum Weight: 14 ounces per square yard.
 - 2. Tensile Strength: 450 pounds of force per inch in the warp and 340 pounds of force per inch in the filling.
 - 3. Service Temperature: -67 degrees F to 500 degrees F.

PART 3 - EXECUTION

3.1 DUCT ACCESSORIES GENERAL INSTALLATION

- A. Inspect areas to receive air duct accessories. Notify Engineer of conditions that would adversely affect the installation of the dampers. Do not proceed until conditions are corrected.
- B. Install duct accessories according to applicable details in SMACNA's "HVAC Duct Construction Standards--Metal and Flexible" for metal ducts.

- C. Provide duct accessories of materials suited to duct materials; use galvanized-steel accessories in galvanized-steel, stainless-steel accessories in stainless-steel ducts, and aluminum accessories in aluminum ducts.
- D. Do not compress or stretch damper frames into duct or opening.
- E. Handle dampers using sleeve or frame. Do not lift dampers using blades, actuators, or jack shafts.
- F. Adjust duct accessories for proper settings.

3.2 SHEET METAL MATERIALS INSTALLATION

- A. Install bracing for multiple sections to support assembly weights and hold against system pressure. Install bracing as needed.

3.3 BACKDRAFT DAMPERS INSTALLATION

- A. Install backdraft dampers on exhaust fans or exhaust ducts nearest to outside and where indicated. Provide at outside air intakes where motorized dampers are not shown on drawings.

3.4 DAMPERS INSTALLATION

- A. Where installing volume dampers in ducts with liner, avoid damage to and erosion of duct liner.
- B. Provide balancing dampers at points on supply, return, and exhaust systems where branches lead from larger ducts for air balancing. Install at a minimum of two duct widths from each branch takeoff. Provide balancing dampers for all air inlets and outlets.
- C. Install dampers square and free from racking with blade running horizontally.

3.5 CONCEALED DAMPER HARDWARE INSTALLATION

- A. Coordinate location in Reflected Ceiling Plan and color of concealed damper hardware with Architect prior to installation.

3.6 ACCESS DOORS INSTALLATION

- A. Install duct access doors to allow for inspecting, adjusting, and maintaining accessories and terminal units as follows:
 - 1. On both sides of duct coils.
 - 2. Downstream from volume dampers, turning vanes and equipment.
 - 3. Adjacent to fire or smoke dampers, providing access to reset or reinstall fusible links.
 - 4. To interior of ducts for cleaning; before and after each change in direction, at maximum 50-foot (15-m) spacing.
 - 5. Install the following sizes for duct-mounting, rectangular access doors:
 - a. One-Hand or Inspection Access: 8-inches by 5-inches.
 - b. Two-Hand Access: 12-inches by 6-inches.
 - c. Head and Hand Access: 18-inches by 10-inches.
 - d. Head and Shoulders Access: 21-inches by 14-inches.

- e. Body Access: 25-inches by 14-inches.
- f. Body Plus Ladder Access: 25-inches by 17-inches.
- 6. Install the following sizes for duct-mounting, round access doors:
 - a. One-Hand or Inspection Access: 8-inches in diameter.
 - b. Two-Hand Access: 10-inches in diameter.
 - c. Head and Hand Access: 12-inches in diameter.
 - d. Head and Shoulders Access: 18-inches in diameter.
 - e. Body Access: 24-inches in diameter.
- 7. Label access doors.

3.7 DUCT TEST HOLES INSTALLATION

- A. Provide test holes at fan inlets and outlets where indicated and where required for air testing and balancing.

3.8 DYNAMIC FIRE DAMPERS INSTALLATION

- A. Adjust fire dampers for proper action.
- B. Install fire dampers, with fusible links, and in accordance with manufacturer's UL approved written instructions.

3.9 CEILING FIRE DAMPERS INSTALLATION

- A. Adjust fire dampers for proper action.
- B. Install fire dampers, with fusible links, and in accordance with manufacturer's UL approved written instructions.

3.10 SMOKE DAMPERS INSTALLATION

- A. Verify that electric power is available and of correct characteristics.
- B. Coordinate smoke dampers with fire alarm system.
- C. Install smoke dampers, with fusible links, and in accordance with manufacturer's UL-approved written instructions.
- D. Adjust fire dampers for proper action.

3.11 COMBINATION FIRE AND SMOKE DAMPERS INSTALLATION

- A. Verify that electric power is available and of correct characteristics.
- B. Coordinate combination fire and smoke dampers with fire alarm system.
- C. Install combination fire and smoke dampers, with fusible links, and in accordance with manufacturer's UL-approved written instructions.
- D. Adjust fire and smoke dampers for proper action.

3.12 TURNING VANES INSTALLATION

- A. Vanes must be installed, eliminating every other vane is not allowed.
- B. Single thickness vanes cannot be over 36-inches long without intermediate vane runner.
- C. Install per SMACNA and fasten/support to prevent vibration, noise, and to maintain proper alignment at design velocity.

3.13 FLEXIBLE CONNECTORS INSTALLATION

- A. Install flexible connectors immediately adjacent to equipment in ducts associated with fans and motorized equipment supported by vibration isolators. Provide sheet metal weather cover over flexible connections located outdoors. Attach sheet metal to either equipment side or ductwork side, but not both.
- B. Per NFPA, do not use flexible connectors on grease exhaust fans.
- C. Securely attach spring-lock brackets to the metal strips of the connector collar using No. 8 sheet metal screws.
- D. For fans developing static pressures of 5-inch wg and higher, cover flexible connectors with loaded vinyl sheet held in place with metal straps.
- E. Adjust the following types in the following locations:
 - 1. FC-I: Indoors.
 - 2. FC-O: Outdoors.
 - 3. FC-HT: High temperature exhaust systems and smoke removal systems.
 - 4. FC-HC: High corrosive systems inclusive of all laboratory exhaust systems.

END OF SECTION

SECTION 23 3400 - HVAC FANS

PART 1 - GENERAL

1.1 SUMMARY

- A. Work Included:
 - 1. Centrifugal Fans
 - 2. Ceiling Exhaust Fans

1.2 RELATED SECTIONS

- A. Contents of Division 23, HVAC and Division 01, General Requirements apply to this Section.

1.3 REFERENCES AND STANDARDS

- A. References and Standards as required by Section 23 00 00, HVAC Basic Requirements and Division 01, General Requirements.

1.4 SUBMITTALS

- A. Submittals as required by Section 23 00 00, HVAC Basic Requirements and Division 01, General Requirements.
- B. In addition, provide:
 - 1. Certified fan performance curves with system operating conditions indicated.
 - 2. Certified fan sound-power ratings.
 - 3. Motor ratings and electrical characteristics, plus motor and electrical accessories.
 - 4. Material gauges and finishes, including color charts.
 - 5. Dampers, including housings, linkages, and operators.

1.5 QUALITY ASSURANCE

- A. Quality assurance as required by Section 23 00 00, HVAC Basic Requirements and Division 01, General Requirements.
- B. In addition, meet the following:
 - 1. Motors: Premium efficiency per Section 23 05 13, Common Motor Requirements for HVAC Equipment. Electrically Commutated Motors (ECM) where scheduled on Drawings.
 - 2. Sound power levels as scheduled on Drawings. If not scheduled, within 5 percent of Basis of Design at design flow.
 - 3. Project Altitude: Base air ratings on sea-level conditions for project sites below 2,000 feet in elevation. Base air ratings on actual site elevations for project sites above 2,000 feet in elevation.
 - 4. Operating Limits: Classify according to AMCA 99.
 - 5. Electrical Components, Devices, and Accessories: Listed and labeled as defined in NFPA 70, Article 100, by a testing agency acceptable to authorities having jurisdiction, and marked for intended use.

6. AMCA Compliance: Products are to comply with performance requirements and are to be licensed to use the AMCA-Certified Ratings Seal.
7. NEMA Compliance: Motors and electrical accessories are to comply with NEMA standards.
8. UL Standard: HVAC Fans are to comply with UL 705. Fans used in grease exhaust applications are to be UL 762 listed for grease exhaust.

1.6 WARRANTY

- A. Warranty of materials and workmanship as required by Section 23 00 00, HVAC Basic Requirements and Division 01, General Requirements.

1.7 DELIVERY, STORAGE, AND HANDLING

- A. Deliver fans as factory-assembled unit, to the extent allowable by shipping limitations, with protective crating and covering.
- B. Disassemble and reassemble units, as required for moving to final location, according to manufacturer's written instructions.
- C. Lift and support units with manufacturer's designated lifting or supporting points.

1.8 COORDINATION

- A. Coordinate size and location of structural-steel support members.
- B. Coordinate size and location of concrete bases. Cast anchor-bolt inserts into bases.
- C. Coordinate installation of roof curbs, equipment supports, and roof penetrations.

1.9 EXTRA MATERIALS

- A. Furnish extra materials described below that match products installed and that are packaged with protective covering for storage and identified with labels describing contents. Belts: One set for each belt-driven unit.

PART 2 - PRODUCTS

2.1 MANUFACTURERS

- A. Centrifugal Fans:
 1. Greenheck
 2. Cook
 3. Twin City
- B. Ceiling Exhaust Fans:
 1. Greenheck
 2. Cook
 3. Broan
 4. Twin City

2.2 CENTRIFUGAL FANS

- A. Description: Centrifugal or utility type centrifugal fans, as indicated, standard factory finish, AMCA rated, single width, single inlet, double width, double inlet, forward curved, backward inclined, or airfoil blades as scheduled.
- B. Wheel and Inlet:
1. Backward Inclined: Steel or aluminum construction with smooth curved inlet flange, heavy back plate, backwardly curved blades welded or riveted to flange and back plate; cast iron or cast steel hub riveted to back plate and keyed to shaft with set screws.
 2. Airfoil Wheel: Steel construction with smooth curved inlet flange, heavy back plate die formed hollow airfoil shaped blades continuously welded at tip flange, and back plate; cast iron or cast steel hub riveted to back plate and keyed to shaft with set screws.
 3. Statically and dynamically balance wheel within its own bearings with maximum balance quality grade at bearings of G16 (0.20 in/sec peak velocity, filter-in as measured at fan RPM) for 5 hp and below and G6.3 (0.15 in/sec peak velocity, filter-in as measured at fan RPM) for 7.5 hp and above per ANSI S2.19. AMCA 210 rated.
- C. Housing:
1. Heavy gauge steel, spot welded for AMCA 99 Class I and II fans, and continuously welded for Class III, adequately braced, designed to minimize turbulence with spun inlet bell and shaped cut.
 2. Finish: Factory finish to manufacturer's standard (Permatector) or Factory finish to manufacturer's standard with Hi-Pro polyester finish exceeding 1,000 hours of salt spray under ASTM B117 test method. For fans handling air downstream of humidifiers, provide two additional coats of paint or fabricate of galvanized steel. Prime coating of aluminum parts is not allowed.
 3. Removable angles and bolts for attaching flexible connections and discharge dampers on fan outlet.
 4. Housing Discharge Arrangement: Adjustable to eight standard positions.
- D. Bearings and Drives
1. Bearings: Heavy duty pillow block type, self-greasing ball bearings, with ABMA 9 L-10 life at 100,000 hours.
 2. Shafts: Hot rolled steel, ground and polished, with keyway, protectively coated with lubricating oil, and shaft guard. Provide anti-corrosive coating.
 3. Drive: Cast iron or steel sheaves, dynamically balanced, keyed. Variable and adjustable pitch sheaves for motors 5 hp and under, selected so required rpm is obtained with sheaves set at mid-position fixed sheave for 7.5 hp and over, matched belts, and drive rated as recommended by manufacturer or minimum 1.5 times nameplate rating of motor.
 4. Belts: Oil resistant, nonsparking, and nonstatic; matched sets for multiple belt drives.
 5. Belt Guard: Fabricate to SMACNA Duct Construction Standards - Metal and Flexible; 0.106-inch thick, 3/4-inch diamond mesh wire screen welded to steel angle frame or equivalent, prime coated. Secure to fan or fan supports without short circuiting vibration isolation, with provision for adjustment of belt tension, lubrication, and use of tachometer with guard in place.
- E. Motor: Integrally mounted, 1800 RPM maximum, with pre-lubricated sealed ball bearings. ODP for motors located indoors and TEFC for motors exposed to moisture.

- F. Accessories:
1. Inlet/Outlet Screens: Galvanized steel welded grid, removable, at unit outlet for outdoor installation, and unit inlet for unducted conditions.
 2. Access Doors: Shaped to conform to scroll, with quick opening latch type handles and gaskets.
 3. Scroll Drain: 1/2-inch steel pipe coupling welded to low point of fan scroll for outdoor installation.
 4. AMCA 99 Type B spark proof construction where scheduled.
 5. Protective coating on fan wheel and interior of fan housing where scheduled. Apply coating before balancing fans and repair any breaks in coating which occur during balancing. One 6-mil coat of white plastic #7122 and one 6-mil coat of black plastic #7122.
 6. Vibration isolation as scheduled and specified. Reference Section 23 05 48, Vibration and Seismic Controls for HVAC Piping and Equipment.

2.3 CEILING EXHAUST FANS

- A. Description: Centrifugal fan, direct drive, cabinet and exhaust grille. AMCA rated. Sound level as scheduled. Fan shrouds, motor, and fan wheel are to be removable for service.
- B. Wheel: Double width, double inlet, forward curved blades:
- C. Housing: Acoustically insulated steel casing, factory standard finish, bottom access through grille, ducted outlet, egg crate inlet grille. Provide stainless steel grille where scheduled.
- D. Drives: Direct drive.
- E. Back draft damper.
- F. Accessories:
1. Disconnect plug.
 2. Flat roof cap.
 3. Hooded wall cap.
 4. Pitched roof cap.
 5. Elbow discharge with grille.
 6. Louvered wall discharge with bird screen.
- G. Motor: Integrally mounted with pre-lubricated sealed ball bearings.
1. Variable-Speed Controller: Where scheduled on Drawings, provide solid-state control to reduce speed from 100 percent to less than 50 percent.
 2. Disconnect Switch: Where not shown on Division 26, Electrical Drawings, provide nonfusible type, with thermal-overload protection mounted inside fan housing factory wired through an internal aluminum conduit.
 3. Manual Starter Switch: Single-pole rocker switch assembly with cover and pilot light.
 4. Time-Delay Switch: Assembly with single-pole rocker switch, timer, and cover plate.
 5. Motion Sensor: Motion detector with adjustable shutoff timer.
 6. Electrically Commutated Motor (ECM) where indicated on Fan Schedule on Drawings.
- H. Filter: Washable aluminum to fit between fan and grille.

- I. Isolation: Rubber-in-shear vibration isolators.

PART 3 - EXECUTION

3.1 GENERAL INSTALLATION REQUIREMENTS

- A. Install in accordance with manufacturer's instructions.
- B. Install power ventilators level and plumb.
- C. Fans used for exhaust of kitchen grease hoods are to be UL 762 listed for grease exhaust. Provide fans with grease terminator. Pipe from grease terminator to Code approved location.
- D. Fans used for exhaust of moist air are to be constructed of aluminum construction and be warranted for their application in moist conditions.
- E. Fans used in welding, chemical, and/or fume exhaust applications are to be of spark-proof construction and are to be protected with coatings as required to protect parts in the air stream from the chemicals and materials the fan will be exposed to.
- F. Install floor-mounting units on concrete bases.
- G. Units using vibration isolation devices are scheduled on Drawings.
- H. Support suspended units from structure threaded steel rods and vibration isolation device scheduled on Drawings.
- I. In seismic zones, restrain support units.
- J. Install units with clearances for service and maintenance.
- K. Provide fixed sheaves required for final air balance.
- L. Provide safety screen where inlet or outlet is exposed.
- M. Pipe scroll drains to nearest floor drain.
- N. Provide backdraft dampers on discharge of exhaust fans and as indicated on Drawings.
- O. Duct installation and connection requirements are specified in other Division 23, HVAC Sections. Drawings indicate general arrangement of ducts and duct accessories. Make final duct connections with flexible connectors per Section 23 33 00, Air Duct Accessories.
- P. Install ducts adjacent to power ventilators to allow service and maintenance.
- Q. Ground equipment.
- R. Tighten electrical connectors and terminals according to manufacturer's published torque-tightening values. If manufacturer's torque values are not indicated, use those specified in UL 486A and UL 486B.

- S. Equipment Startup Checks:
1. Verify that shipping, blocking, and bracing are removed.
 2. Verify that unit is secure on mountings and supporting devices and that connections to ducts and electrical components are complete. Verify that proper thermal-overload protection is installed in motors, starters, and disconnect switches.
 3. Verify that cleaning and adjusting are complete.
 4. Disconnect fan drive from motor, verify proper motor rotation direction, and verify fan wheel free rotation and smooth bearing operation. Reconnect fan drive system, align and adjust belts, and install belt guards.
 5. Verify lubrication from bearings and other moving parts.
 6. Verify that manual and automatic volume control and fire and smoke dampers in connected ductwork systems are in fully open position.
 7. Disable automatic temperature-control operators.
- T. Starting Procedures:
1. Energize motor and adjust fan to indicated rpm.
 2. Measure and record voltage and amperage.
- U. Operational Test: After electrical circuitry has been energized, start units to confirm proper motor rotation and unit operation. Remove malfunctioning units, replace with new units, and retest.
- V. Test and adjust controls and safeties. Replace damaged and malfunctioning controls and equipment.
- W. Shut unit down and reconnect automatic temperature-control operators.
- X. Replace fan and motor pulleys as required to achieve design airflow.
- Y. Provide totally enclosed fan cooled motors when motor is located outdoors, whether under a cover or not, or exposed to moisture. Provide protective covering for electronically commutated motors located in outdoor or wet/wash-down locations.
- Z. Repair or replace malfunctioning units. Retest as specified above after repairs or replacements are made.
- AA. Adjust damper linkages for proper damper operation.
- AB. Adjust belt tension.
- AC. Lubricate bearings.
- AD. On completion of installation, internally clean fans according to manufacturer's written instructions. Remove foreign material and construction debris. Vacuum fan wheel and cabinet.
- AE. After completing system installation, including outlet fitting and devices, inspect exposed finish. Remove burrs, dirt, and construction debris and repair damaged finishes.
- AF. Engage a factory-authorized service representative to train Owner's maintenance personnel to adjust, operate, and maintain HVAC fans. Train Owner's maintenance personnel on procedures

and schedules for starting and stopping, troubleshooting, servicing, and maintaining equipment and schedules.

3.2 CEILING EXHAUST FANS

- A. Suspend units from structure; use steel wire or metal straps.

END OF SECTION

SECTION 23 3700 - AIR OUTLETS AND INLETS

PART 1 - GENERAL

1.1 SUMMARY

- A. Work Included:
 - 1. Grilles, Registers, Diffusers
 - 2. Louvers
 - 3. Roof Vents
 - 4. Goosenecks

1.2 RELATED SECTIONS

- A. Contents of Division 23, HVAC and Division 01, General Requirements apply to this Section.

1.3 REFERENCES AND STANDARDS

- A. References and Standards as required by Section 23 00 00, HVAC Basic Requirements and Division 01, General Requirements.

1.4 SUBMITTALS

- A. Submittals as required by Section 23 00 00, HVAC Basic Requirements and Division 01, General Requirements.
- B. In addition, provide:
 - 1. Data Sheet: For each type of air outlet and inlet, and accessory furnished; indicate construction, finish, and mounting details.
 - 2. Performance Data: Include throw and drop, static-pressure drop, and noise ratings for each type of air outlet and inlet.
 - 3. Schedule of diffusers, registers, and grilles indicating drawing designation, room location, quantity, model number, size and accessories furnished.

1.5 QUALITY ASSURANCE

- A. Quality assurance as required by Section 23 00 00, HVAC Basic Requirements and Division 01, General Requirements.
- B. In addition, meet the following:
 - 1. Air Distribution Diffuser, Register, and Grille Schedule lists Basis of Design, with any specialty accessories, construction, finish or other criteria noted on schedule. Submitted air distribution must match criteria of Basis of Design:
 - a. Construction materials and appearance.
 - b. Frame/installation method.
 - c. Isothermal throw plus or minus 5 percent at design flows shown on drawings.
 - d. Noise Criteria: NC value plus or minus 1 at design flows shown on drawings.
 - e. Accessories: Equal to Basis of Design.

1.6 WARRANTY

- A. Warranty of materials and workmanship as required by Section 23 00 00, HVAC Basic Requirements and Division 01, General Requirements.

PART 2 - PRODUCTS

2.1 MANUFACTURERS

- A. General: Manufacturer's standard products of categories and types required for each application as referenced in other Division 23, HVAC sections, where more than a single type is specified for the application, provide single selection for each product category.
- B. Grilles, Registers, Diffusers:
 - 1. Anemostat
 - 2. Carnes
 - 3. Environmental Air Products
 - 4. Krueger
 - 5. Metalaire
 - 6. Nailor
 - 7. Price Co.
 - 8. Shoemaker
 - 9. Titus
 - 10. Tuttle & Bailey
 - 11. Seiho
 - 12. Or approved equivalent.
- C. Louvers:
 - 1. Ruskin Manufacturing
 - 2. Pottorff
 - 3. Carnes
 - 4. Cesco
 - 5. Greenheck
 - 6. Or approved equivalent.
- D. Roof Vents:
 - 1. Western
 - 2. Or approved equivalent.

2.2 GRILLES, REGISTERS, DIFFUSERS

- A. Diffuser, Register and Grille Schedule lists Basis of Design, with specialty accessories, construction, finish or other criteria noted on schedule. Submitted air distribution must match criteria of Basis of Design, including accessories and finish:
 - 1. Matching construction materials and appearance. Equal installation method/frame.
 - 2. Pressure drop equal to or less than Basis of Design at CFM on Drawings.
 - 3. Throw: Isothermal jet throw plus or minus 5 percent of Basis of Design at CFM listed on Drawings.

4. Noise Criteria: Plus or minus 1 NC of Basis of Design at CFM listed on Drawings. If Basis of Design NC is below registered level, submitted must match. NC rating with 10 dB room factor or less.
- B. Provide 1-, 2-, 3-, or 4-way deflection as indicated on Drawings.
- C. Provide pattern controllers for linear supply air diffusers.
- D. Register Dampers: Dampers utilized with grilles. Opposed blade dampers utilizing a side operated worm drive which provides external duct operation. Slot the end of the shaft to receive a screwdriver. Factory assembled side operator. Construct of the same material as the grille. Manufacturer same as grilles/diffuser.
- E. Coordinate mounting frames with ceiling construction type. Verify per reflected ceiling plans.

2.3 LOUVERS

- A. General: Frame and sill styles compatible with adjacent substrate, specifically manufactured to fit into construction openings with accurate fit and adequate support for weatherproof installation. Reference Drawings and Specifications for types of substrate which will contain each type of louver. Construct of aluminum extrusions, ASTM B221, Alloy 6063-T5. Weld units or use stainless steel fasteners. On inside face of exterior louvers, provide anodized aluminum wire bird screen mounted in removable extruded aluminum frames. AMCA licensed performance ratings.
- B. Blades set 3 to 5-inches on center, 37.5 degree angle with rain hook on blade, minimum blade thickness 0.080-inch, drainable blade style. Minimum 57 percent free area for 48-by 48-inch unit. Maximum water penetration 0.01 ounce water psf free area at 1000 FPM. Maximum intake pressure drop of 0.10-inch wg at 750 FPM free velocity. Provide downspouts in jambs, designed to drain water from louver for minimum water cascade from blade to blade. Provide drain gutter in head frame and each blade.
- C. Reference Drawings for free area required.
- D. Provide access door in duct to clean birdscreen.
- E. Finish: Factory Kynar 500 fluoropolymer spray finish; color to be selected by Architect. Conform to AAMA 605.2. Apply coating following cleaning, and pretreatment. Dry louvers before final finish application. 1.2 mils total dry film thickness when baked at 450 degrees F for ten minutes.

2.4 ROOF VENTS

- A. Standard Type: Furnish and install to match roof exhaust fan hoods. Sizes shown on Drawings. Provide accessories, such as inlet motorized damper, curb, screens per drawings and schedule.
- B. Turbine Type: Furnish and install Turbine Roof Ventilator.

2.5 GOOSENECKS

- A. Fabricate in accordance with SMACNA HVAC Duct Construction Standards - Metal and Flexible, of minimum 18 gauge galvanized steel.
- B. Mount on minimum 12-inch high curb base where size exceeds 9 x 9-inch.
- C. Provide backdraft damper on outlet per local code.
- D. Aluminum bird screen on outlet; 1/4-inch mesh unless noted on Drawings. Coordinate flashing with roofing type.

PART 3 - EXECUTION

3.1 GENERAL INSTALLATION

- A. Install in accordance with manufacturer's instructions. Provide seismic supports, clips, and bracing per local code. Coordinate installation of framing. Provide complete coverage of rough openings by integral device flanges or auxiliary frames. Where above ceiling location is unconditioned space, caulk rough openings; repair and re-paint locations where dust entrainment streaks develop due to unsealed openings.
- B. Damp locations, such as lockers, restrooms, showers, natatoriums, whirlpool/spas, to have aluminum construction even if scheduled otherwise; mounting hardware to be stainless steel.
- C. Check location of outlets and inlets and make necessary adjustments in position to conform with architectural features, symmetry, and lighting arrangement.
- D. Unless otherwise shown on drawings, for ceiling mounted air outlets with adjustable airflow pattern controllers mounted at a height of 12 feet or less, adjust the air outlets for horizontal air distribution, and adjust to vertical air distribution for ceiling height above 12 feet.
- E. Exterior color of grilles per Architect. White finish if not otherwise scheduled or noted by Architect. Paint ductwork visible behind air outlets and inlets matte black.
- F. Ceiling Membrane: Protect ceiling membrane per code. Fire caulk around openings. Provide listed radiation damper in rated roof/ceiling or floor/ceiling assemblies as required per code.
- G. After installation of diffusers, registers, and grilles, inspect exposed finish. Clean exposed surfaces to remove burrs, dirt, and smudges. Replace diffusers, registers, and grilles that have damaged finishes.

3.2 GRILLES, REGISTERS AND DIFFUSERS INSTALLATION

- A. Coordinate with Architectural Reflected Ceiling Plan(s). Reflected ceiling plans determine final locations.
- B. Install diffusers to ductwork with air tight connection. 18-inch straight duct section or acoustic plenum at connection. Provide square to round adapters where required for connection to round ducts.

- C. Provide integral balancing dampers for diffusers, and grilles and registers where duct manual balancing dampers are not shown or specified.

- D. Linear Slot Diffusers:
 - 1. Coordinate connection plenum dimensions with linear slot final dimensions to conform with manufacturer's recommendations, or as indicated. Total and active lengths as noted on drawings. Blank off unused sections. Coordinate frame type with Architect.
 - 2. Paint surfaces visible behind air outlets and inlets, including blank-off sections, matte black unless otherwise called for on drawings.

END OF SECTION

SECTION 23 4000 - HVAC AIR CLEANING DEVICES

PART 1 - GENERAL

1.1 SUMMARY

- A. Work Included:
 - 1. Disposable Panel Filters
 - 2. Medium Efficiency Pleated Filters
 - 3. High Efficiency Pleated Filters
 - 4. Filter Gauges

1.2 RELATED SECTIONS

- A. Contents of Division 23, HVAC and Division 01, General Requirements apply to this Section.
- B. In addition, reference the following:
 - 1. Division 01, General Requirements, Temporary Facilities and Controls: Filters for temporary heating and ventilating.
 - 2. Division 26, Electrical, Equipment Wiring: Electrical characteristics and wiring connections.

1.3 REFERENCES AND STANDARDS

- A. References and Standards as required by Section 23 00 00, HVAC Basic Requirements and Division 01, General Requirements.
- B. In addition, meet the following:
 - 1. ANSI/AHRI 850 I-P - Performance Rating of Commercial and Industrial Air Filter Equipment.
 - 2. ASHRAE Std 52.1 - Gravimetric and Dust-Spot Procedures for Testing Air Cleaning Devices Used in General Ventilation for Removing Particulate Matter; American Society of Heating, Refrigerating and Air-Conditioning Engineers, Inc.
 - 3. ASHRAE Std 52.2 - Method of Testing General Ventilation Air-Cleaning Devices for Removal Efficiency by Particle Size; American Society of Heating, Refrigerating and Air-Conditioning Engineers, Inc.
 - 4. Standard 52.2 - Method of testing general ventilation air-cleaning devices for removal efficiency by particle size.
 - 5. MIL-STD-282 - Filter Units, Protective Clothing, Gas-Mask Components, and Related Products: Performance-Test Methods; Military Specifications and Standards.
 - 6. UL 586 - High Efficiency, Particulate, Air Filter Units; Underwriters Laboratories Inc.
 - 7. UL 867 - Electrostatic Air Cleaners; Underwriters Laboratories Inc.
 - 8. UL 900 - Standard for Air Filter Units; Underwriters Laboratories Inc.

1.4 SUBMITTALS

- A. Submittals as required by Section 23 00 00, HVAC Basic Requirements and Division 01, General Requirements.
- B. In addition, provide:

1. Product Data: Provide data on filter media, filter performance data, filter assembly and filter frames, dimensions, motor locations and electrical characteristics and connection requirements.
2. Shop Drawings: Indicate filter assembly and filter frames, dimensions, motor locations, and electrical characteristics and connection requirements.
3. Samples: Submit two samples of replacement filter media of each type and each filter frame.
4. Manufacturer's Installation Instructions: Indicate assembly and change-out procedures.
5. Operation and Maintenance Data: Include instructions for operation, changing, and periodic cleaning.
6. Maintenance Materials: Furnish the following for Owner's use in maintenance of project.
 - a. See Division 01, General Requirements for additional provisions.
 - b. Extra Filters: One set of each type and size.

1.5 QUALITY ASSURANCE

- A. Quality assurance as required by Section 23 00 00, HVAC Basic Requirements and Division 01, General Requirements.
- B. In addition, meet the following:
 1. Products Requiring Electrical Connection: Listed and classified by Underwriters Laboratories Inc. as suitable for the purpose specified and indicated.

1.6 WARRANTY

- A. Warranty of materials and workmanship as required by Section 23 00 00, HVAC Basic Requirements and Division 01, General Requirements.

1.7 PERFORMANCE REQUIREMENTS

- A. Conform to ANSI/AHRI 850 I-P - Performance Rating of Commercial and Industrial Air Filter Equipment, Section 7.4.
 1. Dust Spot Efficiency: Plus or minus 5 percent.

PART 2 - PRODUCTS

2.1 MANUFACTURERS

- A. Filters:
 1. American Filtration Inc.
 2. AAF International/American Air Filter
 3. Camfil Farr Company
 4. Eco-Air Products
 5. Filtration Group
 6. Flanders Corporation
 7. Or approved equivalent.
- B. Filter Gauges:
 1. Dwyer Instruments
 2. H.O. Treric Co.

3. Weiss Instruments
4. Or approved equivalent.

2.2 DISPOSABLE PANEL FILTERS

- A. Media: UL 900 Class 2, fiber blanket, factory sprayed with flameproof, non-drip, non-volatile adhesive.
 1. Nominal Size: 12 x 24-inches.
 2. Thickness: 1-inch.
- B. Performance Rating:
 1. Face Velocity: 500 FPM.
 2. Face Velocity: 350 FPM (2.54 m/sec).
 3. Initial Resistance: 0.15-inch WG.
 4. Initial Resistance: 0.23-inch WG (37 Pa).
 5. Recommended Final Resistance: 0.50-inches WG.
 6. MERV Rating: 6.
- C. Casing: Cardboard frame.
- D. Holding Frames: 20 gauge minimum galvanized steel frame with expanded metal grid on outlet side and steel rod grid on inlet side, hinged with pull and retaining handles.

2.3 MEDIUM EFFICIENCY PLEATED FILTERS

- A. Media: Blend of cotton and polyester fiber, pleated, support grid, enclosing frame, UL 900.
 1. Thickness 2-inch.
- B. Performance Rating per ASHRAE Standard 52.2:
 1. MERV 7.
 2. Dust Spot Efficiency: 25 to 30 percent.
 3. Face Velocity: 500 FPM.
 4. Initial Resistance: 0.30-inch WG.
 5. Recommended Final Resistance: 0.90-inches WG.
- C. Frame: Provide galvanized steel frame, including support hardware with air tight seal around frame, upstream servicing.

2.4 HIGH EFFICIENCY PLEATED FILTERS

- A. Media: Microfine glass fiber laminated to reinforcing backing, pleated, support grid, mechanically and chemically bonded to enclosing frame, UL Class 1.
 1. Thickness: 12-inch.
- B. Performance Rating per ASHRAE Standard 52.1 and Standard 52.2:
 1. MERV 9.
 2. Dust Spot Efficiency: 40 to 45 percent.
 3. Face Velocity: 500 FPM.
 4. Initial Resistance: 0.25 inch WG.
 5. Recommended Final Resistance: 1.50-inches WG.

- C. Frame: Provide galvanized steel frame, including support hardware with air tight seal around frame, upstream servicing.

2.5 FILTER GAUGES

- A. Direct Reading Dial: 3-1/2-inch diameter diaphragm actuated dial in metal case, vent valves, black figures on white background, front recalibration adjustment, range 0-0.5-inch WG, 2 percent of full scale accuracy.
- B. Direct Reading Dial: 2-inch diameter diaphragm actuated dial in metal case, vent valves, black figures on white background, front recalibration adjustment, range 2.0-inch WG, 3 percent of full scale accuracy.
- C. Inclined Manometer: One piece molded plastic with epoxy coated aluminum scale, inclined-vertical indicating tube and built-in spirit level, range 0-3-inch WG, 3 percent of full scale accuracy.
- D. Accessories: Static pressure tips with integral compression fittings, 1/4-inch aluminum tubing, 2-way or 3-way vent valves.

PART 3 - EXECUTION

3.1 GENERAL INSTALLATION REQUIREMENTS

- A. Install air cleaning devices in accordance with manufacturer's instructions.
- B. Prevent passage of unfiltered air around filters with felt, rubber, or neoprene gaskets.
- C. Furnish and install filter gauge static pressure tips upstream and downstream of filters. Mount filter gauges on outside of filter housing or filter plenum, in accessible position/location. Adjust and level.
- D. Operation During Construction: If air handlers are operated during construction, provide treated 2-inch media construction filter in front of prefilters and replace periodically to prevent dirt carryover. Install clean prefilters prior to air balancing.
- E. Do not operate fan system until filters (temporary or permanent) are in place. Replace temporary filters used during construction and testing, with clean set.
- F. Provide filter gauges on filter banks, installed with separate static pressure tips upstream and downstream of filters.

3.2 SCHEDULES

- A. Air Filter Schedule
- B. Drawing Code
- C. Location

- D. Type
- E. Number
- F. Size
- G. Air Flow
- H. Face Velocity
- I. Overall Height
- J. Overall Width
- K. Initial Resistance
- L. Final Resistance

END OF SECTION

SECTION 23 8126 - SMALL SPLIT SYSTEM AND UNITARY HVAC EQUIPMENT

PART 1 - GENERAL

1.1 SUMMARY

- A. Work Included: Materials, installation and testing of:
 - 1. Water Source Heat Pumps (Under 6-Tons)

1.2 RELATED SECTIONS

- A. Contents of Section 23 00 00, HVAC Basic Requirements and Division 1, General Requirements apply to this Section.

1.3 REFERENCES AND STANDARDS

- A. References and Standards as required by Section 23 00 00, HVAC Basic Requirements and Division 1, General Requirements.
- B. In addition, meet the following:
 - 1. AHRI 210/240 - Performance Rating of Unitary Air-Conditioning and Air-Source Heat Pump Equipment.

1.4 SUBMITTALS

- A. Submittals as required by Section 23 00 00, HVAC Basic Requirements and Division 1, General Requirements.

1.5 QUALITY ASSURANCE

- A. Quality assurance as required by Section 23 00 00, HVAC Basic Requirements and Division 1, General Requirements.
- B. In addition, meet the following:
 - 1. Efficiency ratings, cooling/heating performance, fan performance, sound performance to meet or exceed Basis of Design as scheduled on Drawings.

1.6 WARRANTY

- A. Warranty of materials and workmanship as required by Section 23 00 00, HVAC Basic Requirements and Division 1, General Requirements.
- B. In addition, provide:
 - 1. Refrigeration compressor(s): 5-year warranty.
 - 2. Furnace heat exchanger: 5-year warranty.

PART 2 - PRODUCTS

2.1 MANUFACTURERS

- A. Water Source Heat Pumps (Under 6-Tons):

1. Bosch (Florida Heat Pump)
2. Climate Master
3. Trane
4. Daikin Applied
5. Water Furnace Intl.
6. Or approved equivalent.

2.2 WATER SOURCE HEAT PUMPS (UNDER 6-TONS)

- A. Description: Packaged water source unit for use with fluid source, type and temperatures as scheduled. Self contained unit factory-tested and assembled, factory wired, refrigerant-to-water heat exchanger, air-to-refrigerant heat exchanger, fan/motor assembly, compressor, reversing refrigerant circuit, metering device, filter, controls and safety devices, control circuit transformer, shipped in one piece with AHRI certification and UL listing. Provide access to all serviceable components and to permit field servicing and replacement.
- B. Components:
1. Casing and Cabinet: heavy-gauge galvanized steel finished; minimum 1/2-inch thick, 1-1/2# liner with cleanable facing on all surfaces in air stream. Insulated compressor housing. Easily removed access panels. Filter housing suitable for two-inch thick filters.
 2. Internal secondary pump.
 3. Supplemental Heat: Electric Heat.
 4. Hoses: Stainless Steel braid over nontoxic synthetic polymer.
 5. Schedule expected radiated sound level at full load operation.
 6. Electrical: Control box with magnetic contactors, separate fusing for compressors, and evaporator fans, and control transformer. Solid state control with all safeties/shutdown, sequencing and flow control. Arrange unit for single point electrical connection. Provide field wiring for thermostat.
 7. Epoxy coated evaporator coil; Cupro-nickel water-refrigerant heat exchanger.
 8. Energy Star labeled.
- C. Refrigeration System:
1. Refrigerant: HFC Refrigerant or other refrigerant with zero ozone depletion potential (ODP).
 2. Compressor: High Efficiency rotary or scroll type, reversing valves, thermostatic expansion valve, full vibration isolation, high low pressure switch.
 3. Heat Exchanger: Water-to-refrigerant rated at minimum 400 PSIG, insulated, corrosion-resistant materials/coatings.
- D. Air System:
1. Supply Fan: Forward curve, direct drive, draw through, corrosion resistant galvanized steel.
 2. Supply Fan Motor: Permanent split capacitor (PSC) with thermal overload protection, permanently lubricated bearings.
 3. Evaporator Coil: Seamless copper tubes expanded into aluminum fins.
 4. Filter: MERV 8 or MERV 13, two-inch thick, pleated, throw-away.
- E. Condensate Drain:
1. Condensate pump kit.
 2. Secondary drain pan; Condensate overflow shut-off float switch and external alarm.

3. Provide evaporator drain pan sloped to drain away from unit.
- F. Controls: Include low/high pressure switch with compressor lockout, and condensate overflow detection, normally closed two position valve wired to open when compressor runs. Controls are to be capable of communication to/from building DDC control system. BAS system interface for Lonworks, BACnet, Modbus, Johnson Controls N2, or programmable thermostat.

PART 3 - EXECUTION

3.1 GENERAL INSTALLATION REQUIREMENTS

- A. Install with required clearances and access for maintenance.
- B. Install factory furnished devices for field installation.
- C. Inspect for and remove shipping bolts, blocks and tie-down straps.
- D. After energizing units: Test units for proper fan rotation. Test and adjust controls and internal safeties. Replace malfunctioning units and retest.
- E. Thoroughly clean exposed portions of equipment. Install new filters prior to final test and balance and again prior to final acceptance.
- F. Provide vibration isolation: As scheduled.
- G. Provide seismic restraint.
- H. Condensate drain per manufacturer's piping diagram.
- I. Condensate piped to indirect waste connection; cleanouts at changes of direction; sized and sloped to drain per Code. Secondary drain routed to visible location.
- J. Shut-off/hose kits for all hydronic connections.

END OF SECTION

SECTION 26 0000 - ELECTRICAL BASIC REQUIREMENTS

PART 1 - GENERAL

1.1 SECTION INCLUDES

- A. Work included in 26 00 00, Electrical Basic Requirements applies to Division 26, Electrical work to provide materials, labor, tools, permits, incidentals, and other services to provide and make ready for Owner's use of electrical systems for proposed project.
- B. Contract Documents include, but are not limited to, Specifications including Division 00, Procurement and Contracting Requirements and Division 01, General Requirements, Drawings, Addenda, Owner/Architect Agreement, and Owner/Contractor Agreement. Confirm requirements before commencement of work.
- C. Definitions:
 - 1. Provide: To furnish and install, complete and ready for intended use.
 - 2. Furnish: Supply and deliver to project site, ready for unpacking, assembly and installation.
 - 3. Install: Includes unloading, unpacking, assembling, erecting, installation, applying, finishing, protecting, cleaning and similar operations at project site as required to complete items of work furnished.
 - 4. Approved or Approved Equivalent: To possess the same performance qualities and characteristics and fulfill the utilitarian function without any decrease in quality, durability or longevity. For equipment/products defined by the Contractor as "equivalent", substitution requests must be submitted to Engineer for consideration, in accordance with Division 01, General Requirements, and approved by the Engineer prior to submitting bids for substituted items.
 - 5. Authority Having Jurisdiction (AHJ): Indicates reviewing authorities, including local fire marshal, Owner's insurance underwriter, Owner's Authorized Representative, and other reviewing entity whose approval is required to obtain systems acceptance.

1.2 RELATED SECTIONS

- A. Contents of Section applies to Division 26, Electrical Contract Documents.
- B. Related Work:
 - 1. Additional conditions apply to this Division including, but not limited to:
 - a. Specifications including Division 00, Procurement and Contracting Requirements and Division 01, General Requirements.
 - b. Drawings
 - c. Addenda
 - d. Owner/Architect Agreement
 - e. Owner/Contractor Agreement
 - f. Codes, Standards, Public Ordinances and Permits

1.3 REFERENCES AND STANDARDS

- A. References and Standards per Division 00, Procurement and Contracting Requirements and Division 01, General Requirements, individual Division 26, Electrical Sections and those listed in this Section.
- B. Codes to include latest adopted editions, including current amendments, supplements and local jurisdiction requirements in effect as of the date of the Contract Documents, of/from:
1. State of Virginia:
 - a. 2012 International Building Code (IBC) with corresponding Virginia Construction Code Supplement
 - b. 2012 International Mechanical Code (IMC) with corresponding Virginia Construction Code Supplement
 - c. 2012 International Plumbing Code (IPC) with corresponding Virginia Construction Code Supplement
 - d. 2012 International Fuel Gas Code (IFGC) with corresponding Virginia Construction Code Supplement
 - e. 2012 National Electric Code (NFPA 70-2011) with corresponding Virginia Construction Code Supplement
 - f. 2012 International Energy Conservation Code (IECC) with corresponding Virginia Construction Code Supplement
- C. Reference standards and guidelines include but are not limited to the latest adopted editions from:
1. ABA - Architectural Barriers Act
 2. ADA - Americans with Disabilities Act
 3. ANSI - American National Standards Institute
 4. APWA - American Public Works Association
 5. ASCE - American Society of Civil Engineers
 6. ASHRAE Guideline 0, the Commissioning Process
 7. ASTM - ASTM International
 8. CFR - Code of Federal Regulations
 9. EPA - Environmental Protection Agency
 10. ETL - Electrical Testing Laboratories
 11. FCC - Federal Communications Commission
 12. FM - FM Global
 13. IBC - International Building Code
 14. IEC - International Electrotechnical Commission
 15. IEEE - Institute of Electrical and Electronics Engineers
 16. IES - Illuminating Engineering Society
 17. ISO - International Organization for Standardization
 18. MSS - Manufacturers Standardization Society
 19. NEC - National Electric Code
 20. NECA - National Electrical Contractors Association
 21. NEMA - National Electrical Manufacturers Association
 22. NETA - National Electrical Testing Association
 23. NFPA - National Fire Protection Association
 24. OSHA - Occupational Safety and Health Administration

25. UL - Underwriters Laboratories Inc.

D. See Division 26, Electrical individual Sections for additional references.

1.4 SUBMITTALS

A. See Division 01, General Requirements for Submittal Procedures as well as individual Division 26, Electrical Sections.

B. Provide drawings in format and software release equal to the design documents. Drawings to be the same sheet size and scale as the Contract Documents.

C. In addition:

1. "No Exception Taken" constitutes that review is for general conformance with the design concept expressed in the Contract Documents for the limited purpose of checking for conformance with information given. Any action is subject to the requirements of the Contract Documents. Contractor is responsible for the dimensions and quantity and will confirm and correlate at the job site, fabrication processes and techniques of construction, coordination of the work with that of all other trades, and the satisfactory performance of the work.
2. Provide product submittals and shop drawings in electronic format only. Electronic format must be submitted via zip file via e-mail. For electronic format, provide one file per division containing one bookmarked PDF file with each bookmark corresponding to each Specification Section. Arrange bookmarks in ascending order of Specification Section number. Individual submittals sent piecemeal in a per Specification Section method will be returned without review or comment. All transmissions/submissions to be submitted to Architect. Deviations will be returned without review.
 - a. Provide separate submittals for power system study (per Specification Section 26 05 73) and electrical equipment (for example, switchboards and panelboards).
 - b. Provide separate submittals for lighting control cutsheets, and for lighting control shop drawings.
3. Product Data: Provide manufacturer's descriptive literature for products specified in Division 26, Electrical Sections.
4. Identify/mark each submittal in detail. Note what differences, if any, exist between the submitted item and the specified item. Failure to identify the differences will be considered cause for disapproval. If differences are not identified and/or not discovered during the submittal review process, Contractor remains responsible for providing equipment and materials that meet the specifications and drawings.
 - a. Label submittal to match numbering/references as shown in Contract Documents. Highlight and label applicable information to individual equipment or cross out/remove extraneous data not applicable to submitted model. Clearly note options and accessories to be provided, including field installed items. Highlight connections by/to other trades.
 - b. Include technical data, installation instructions and dimensioned drawings for products, fixtures, equipment and devices installed, furnished or provided. Reference individual Division 26, Electrical specification Sections for specific items required in product data submittal outside of these requirements.
 - c. See Division 26, Electrical individual Sections for additional submittal requirements outside of these requirements.

5. Maximum of two reviews of complete submittal package. Arrange for additional reviews and/or early review of long-lead items; Bear costs of these additional reviews at Engineer's hourly rates. Incomplete submittal packages/submittals will be returned to contractor without review.
6. Resubmission Requirements: Make corrections or changes in submittals as required, and in consideration of Engineer's comments. Identify Engineer's comments and provide an individual response to each of the Engineer's comments. Cloud changes in the submittals and further identify changes which are in response to Engineer's comments.
7. Trade Coordination: Include physical characteristics, electrical characteristics, device layout plans, wiring diagrams, and connections as required per Division 26, Electrical Coordination Documents. For equipment with electrical connections, furnish copy of approved submittal for inclusion in Division 26, Electrical submittals. Electric motors are supplied and installed by Division 23 unless otherwise specified. During shop drawing stage of the project, verify correct disconnect sizes, conductor sizes, etc., and bring any discrepancies to the attention of the Mechanical trade. Be responsible for any modifications to electrical equipment or installations as a result of equipment incompatibility discovered after shop drawing review.
8. Make provisions for openings in building for admittance of equipment prior to start of construction or ordering of equipment.
9. Substitutions and Variation from Basis of Design:
 - a. The Basis of Design designated product establishes the qualities and characteristics for the evaluation of any comparable products by other listed acceptable manufacturers if included in this Specification or included in an approved Substitution Request as judged by the Design Professional.
 - b. If substitutions and/or equivalent equipment/products are being proposed, it is the responsibility of parties concerned, involved in, and furnishing the substitute and/or equivalent equipment to verify and compare the characteristics and requirements of that furnished to that specified and/or shown. If greater capacity and/or more materials and/or more labor is required for the rough-in, circuitry or connections than for the item specified and provided for, then provide compensation for additional charges required for the proper rough-in, circuitry and connections for the equipment being furnished. No additional charges above the Base Bid, including resulting charges for work performed under other Divisions, will be allowed for such revisions. Coordinate with the requirements of "Submittals". For any product marked "or approved equivalent", a substitution request must be submitted to Engineer for approval prior to purchase, delivery or installation.
10. Shop Drawings: Provide coordinated shop drawings which include physical characteristics of all systems, device layout plans, and control wiring diagrams. Reference individual Division 26, Electrical specification Sections for additional requirements for shop drawings outside of these requirements.
 - a. Provide Shop Drawings indicating access panel locations, size and elevation for approval prior to installation.
11. Samples: Provide samples when requested by individual Sections.
12. Resubmission Requirements:
 - a. Make any corrections or change in submittals when required. Provide submittals as specified. The engineer will not be required to edit and/or interpret the Contractor's submittals. Indicate changes for the resubmittal in a cover letter with reference to page(s) changed and reference response to comment. Cloud changes in the submittals.

- b. Resubmit for review until review indicates no exception taken or "make corrections as noted".
13. Operation and Maintenance Manuals, Owner's Instructions:
- a. Submit, at one time, electronic files (PDF format) of manufacturer's operation and maintenance instruction manuals and parts lists for equipment or items requiring servicing. Submit data when work is substantially complete and in same order format as submittals. Include name and location of source parts and service for each piece of equipment.
 - 1) Include copy of approved submittal data along with submittal review letters received from Engineer. Data to clearly indicate installed equipment model numbers. Delete or cross out data pertaining to other equipment not specific to this project.
 - 2) Include copy of manufacturer's standard Operations and Maintenance for equipment. At front of each tab, provide routine maintenance documentation for scheduled equipment. Include manufacturer's recommended maintenance schedule and highlight maintenance required to maintain warranty. Furnish list of routine maintenance parts, including part numbers, sizes, quantities, relevant to each piece of equipment.
 - 3) Include Warranty per Division 00, Procurement and Contracting Requirements and Division 01, General Requirements, Section 26 00 00, Electrical Basic Requirements and individual Division 26, Electrical Sections.
 - 4) Include product certificates of warranties and guarantees.
 - 5) Include copy of complete parts list for equipment. Include available exploded views of assemblies and sub assemblies.
 - 6) Include commissioning reports.
 - 7) Include copy of startup and test reports specific to each piece of equipment.
 - 8) Engineer will return incomplete documentation without review. Engineer will provide one set of review comments in Submittal Review format. Contractor must arrange for additional reviews; Contractor to bear costs for additional reviews at Engineer's hourly rates.
 - b. Thoroughly instruct Owner in proper operation of equipment and systems. Where noted in individual Sections, training will include classroom instruction with applicable training aids and systems demonstrations. Field instruction per Section 26 00 00, Electrical Basic Requirements, Demonstration.
 - c. Copies of certificates of code authority inspections, acceptance, code required acceptance tests, letter of conformance and other special guarantees, certificates of warranties, specified elsewhere or indicated on Drawings.
14. Record Drawings:
- a. Maintain at site at least one set of drawings for recording "As-constructed" conditions. Indicate on drawings changes to original documents by referencing revision document, and include buried elements, location of conduit, and location of concealed electrical items. Include items changed by field orders, supplemental instructions, and constructed conditions.
 - b. Record Drawings are to include equipment and fixture/connection schedules that accurately reflect "as constructed or installed" for project.
 - c. At completion of project, input changes to original project on Revit Model and make one set of black-line drawings created from Revit Model in version/release equal to contract drawings. Submit Revit disk and drawings upon substantial completion.

- d. See Division 26, Electrical individual Sections for additional items to include in record drawings.

1.5 QUALITY ASSURANCE

- A. Regulatory Requirements: Work and materials installed to conform with all local, State and Federal codes, and other applicable laws and regulations. Where code requirements are at variance with Contract Documents, meet code requirements as a minimum requirement and include costs necessary to meet these in Contract. Machinery and equipment are to comply with OSHA requirements, as currently revised and interpreted for equipment manufacturer requirements. Install equipment provided per manufacturer recommendations.
- B. Whenever this Specification calls for material, workmanship, arrangement or construction of higher quality and/or capacity than that required by governing codes, higher quality and/or capacity take precedence.
- C. Drawings are intended to be diagrammatic and reflect the Basis of Design manufacturer's equipment. They are not intended to show every item in its exact dimensions, or details of equipment or proposed systems layout. Verify actual dimensions of systems (i.e. distribution equipment, duct banks, light fixtures, etc.) and equipment proposed to assure that systems and equipment will fit in available space. Contractor is responsible for design and construction costs incurred for equipment other than Basis of Design, including, but not limited to, architectural, structural, electrical, HVAC, fire sprinkler, and plumbing systems.
- D. Manufacturer's Instructions: Follow manufacturer's written instructions. If in conflict with Contract Documents, obtain clarification. Notify Engineer/Architect, in writing, before starting work.
- E. Items shown on Drawings are not necessarily included in Specifications or vice versa. Confirm requirements in all Contract Documents.
- F. Provide products that are UL listed.

1.6 WARRANTY

- A. Provide written warranty covering the work for a period of one year from date of Substantial Completion in accordance with Division 00, Procurement and Contracting Requirements and Division 01, General Requirements, Section 26 00 00, Electrical Basic Requirements and individual Division 26, Electrical Sections.
- B. Sections under this Division can require additional and/or extended warranties that apply beyond basic warranty under Division 01, General Requirements and the General Conditions. Confirm requirements in all Contract Documents.

1.7 COORDINATION DOCUMENTS

- A. Prior to construction, coordinate installation and location of HVAC equipment, ductwork, grilles, diffusers, piping, plumbing equipment/fixtures, fire sprinklers, plumbing, lights, cable tray and electrical services with architectural and structural requirements, and other trades (including ceiling suspension and tile systems), and provide maintenance access requirements. Coordinate with submitted architectural systems (i.e. roofing, ceiling, finishes) and structural

systems as submitted, including footings and foundation. Identify zone of influence from footings and ensure systems are not routed within the zone of influence.

- B. Advise Architect in event a conflict occurs in location or connection of equipment. Bear costs resulting from failure to properly coordinate installation or failure to advise Architect of conflict.
- C. Verify in field exact size, location, and clearances regarding existing material, equipment and apparatus, and advise Architect of discrepancies between that indicated on Drawings and that existing in field prior to installation related thereto.
- D. Submit final Coordination Drawings with changes as Record Drawings at completion of project.

1.8 VIRIDIANT REQUIREMENTS

- A. Obtain list of credits sought by project. Be familiar with requirements for credits. See Division 00, Procurement and Contracting Requirements and Division 01, General Requirements for requirements.
- B. Provide materials and services as outlined in appropriate Viridiant Residential Net-Zero Reference Guide.
- C. Provide documentation as outlined in appropriate Viridiant Residential Net-Zero Reference Guide.
- D. Coordinate start-up, testing, training, and installation with Commissioning Agent as required to meet commissioning requirements.
- E. Provide adequate schedule for construction activities such as building flush out.

PART 2 - PRODUCTS

2.1 MANUFACTURERS

- A. Articles, fixtures, and equipment of a kind to be standard product of one manufacturer.

2.2 STANDARDS OF MATERIALS AND WORKMANSHIP

- A. Base contract upon furnishing materials as specified. Materials, equipment, and fixtures used for construction are to be new, latest products as listed in manufacturer's printed catalog data and are to be UL approved or have adequate approval or be acceptable by state, county, and city authorities. Equipment/fixture supplier is responsible for obtaining State, County, and City acceptance on equipment/fixtures that are not UL approved or are not listed for installation.
- B. Names and manufacturer's names denote character and quality of equipment desired and are not to be construed as limiting competition.
- C. Hazardous Materials:
 - 1. Comply with local, State of Virginia, and Federal regulations relating to hazardous materials.

2. Comply with Division 00, Procurement and Contracting Requirements and Division 01, General Requirements for this project relating to hazardous materials.
3. Do not use any materials containing a hazardous substance. If hazardous materials are encountered, do not disturb; immediately notify Owner and Architect. Hazardous materials will be removed by Owner under separate contract.

PART 3 - EXECUTION

3.1 ACCESSIBILITY AND INSTALLATION

- A. Confirm Accessibility and Installation requirements in Division 00, Procurement and Contracting Requirements, Division 01, General Requirements, Section 26 00 00, Electrical Basic Requirements and individual Division 26, Electrical Sections.
- B. Install equipment requiring access (i.e., junction boxes, light fixtures, power supplies, motors, etc.) so that they may be serviced, reset, replaced or recalibrated by service people with normal service tools and equipment. Do not install equipment in passageways, doorways, scuttles or crawlspaces which would impede or block the intended usage.
- C. Install equipment and products complete as directed by manufacturer's installation instructions. Obtain installation instructions from manufacturer prior to rough-in of equipment and examine instructions thoroughly. When requirements of installation instructions conflict with Contract Documents, request clarification from Architect prior to proceeding with installation. This includes proper installation methods, sequencing, and coordination with other trades and disciplines.
- D. Earthwork:
 1. Confirm Earthwork requirements in Contract Documents. In the absence of specific requirements, comply with individual Division 26, Electrical Sections and the following:
 - a. Perform excavation, dewatering, shoring, bedding, and backfill required for installation of work in this Division in accordance with related earthwork Sections. Contact utilities and locate existing utilities prior to excavation. Repair any work damaged during excavation or backfilling.
 - b. Excavation: Do not excavate under footings, foundation bases, or retaining walls.
 - c. Provide protection of underground systems. Review the project Geotechnical Report for references to corrosive or deleterious soils which will reduce the performance or service life of underground systems materials.
- E. Firestopping:
 1. Confirm requirements in Division 07, Thermal and Moisture Protection. In the absence of specific requirements, comply with individual Division 26, Electrical Sections and the following:
 - a. Coordinate location and protection level of fire and/or smoke rated walls, ceilings, and floors. When these assemblies are penetrated, seal around piping and equipment with approved firestopping material. Install firestopping material complete as directed by manufacturer's installation instructions. Meet requirements of ASTM E814, Standard Test Method for Fire Tests of Through-Penetration Fire Stops.
- F. Plenums:

1. In plenums, provide plenum rated materials that meet the requirements to be installed in plenums. Immediately notify Architect/Engineer of discrepancy.
 - G. Start up equipment, in accordance with manufacturer's start-up instructions, and in presence of manufacturer's representative. Test controls and demonstrate compliance with requirements. Replace damaged or malfunctioning controls and equipment.
 - H. Provide miscellaneous supports/metals required for installation of equipment and conduit.
- 3.2 REVIEW AND OBSERVATION
- A. Confirm Review and Observation requirements in Division 00, Procurement and Contracting Requirements, Division 01, General Requirements, Section 26 00 00, Electrical Basic Requirements and individual Division 26, Electrical Sections.
 - B. Notify Architect, in writing, at following stages of construction so that they may, at their option, visit site for review and construction observation:
 1. Underground conduit installation prior to backfilling.
 2. Prior to covering walls.
 3. Prior to ceiling cover/installation.
 4. When main systems, or portions of, are being tested and ready for inspection by AHJ.
 - C. Final Punch:
 1. Prior to requesting a final punch visit from the Engineer, request from Engineer the Electrical Precloseout Checklist, complete the checklist confirming completion of systems' installation, and return to Engineer. Request a final punch visit from the Engineer, upon Engineer's acceptance that the electrical systems are ready for final punch.
 2. Costs incurred by additional trips required due to incomplete systems will be the responsibility of the Contractor.
- 3.3 CONTINUITY OF SERVICE
- A. Confirm requirements in Division 00, Procurement and Contracting Requirements and Division 01, General Requirements. In the absence of specific requirements in Division 01, General Requirements, comply with individual Division 26, Electrical Sections and the following:
 1. During remodeling or addition to existing structure, while existing structure is occupied, present services to remain intact until new construction, facilities or equipment is installed.
 2. Prior to changing over to new service, verify that every item is thoroughly prepared. Install new wiring, and wiring to point of connection.
 3. Coordinate transfer time to new service with Owner. If required, perform transfer during off-peak hours. Once changeover is started, pursue to its completion to keep interference to a minimum.
 - a. If overtime is necessary, there will be no allowance made by Owner for extra expense for such overtime or shift work.
 4. No interruption of services to any part of existing facilities will be permitted without express permission in each instance from Owner. Requests for outages must state specific dates, hours and maximum durations, with outages kept to these specific dates, hours and

maximum durations. Obtain written permission from Owner for any interruption of power, lighting or signal circuits and systems.

- a. Organize work to minimize duration of power interruption.
- b. Coordinate utility service outages with utility company.

3.4 CUTTING AND PATCHING

- A. Confirm requirements in Division 00, Procurement and Contracting Requirements and Division 01, General Requirements. In the absence of specific requirements in Division 01, General Requirements, comply with individual Division 26, Electrical Sections and the following:
1. Proposed floor cutting/core drilling/sleeve locations to be approved by Project Structural Engineer. Submit proposed locations to Architect/Project Structural Engineer. Where slabs are of post tension construction, perform x-ray scan of proposed penetration locations and submit scan results including proposed penetration locations to Project Structural Engineer/Architect for approval. Where slabs are of waffle type construction, show column cap extent and cell locations relative to proposed penetration(s).
 2. Cutting, patching and repairing for work specified in this Division including plastering, masonry work, concrete work, carpentry work, and painting included under this Section will be performed by skilled craftsmen of each respective trade in conformance with appropriate Division of Work.
 3. Additional openings required in building construction to be made by drilling or cutting. Use of jack hammer is specifically prohibited. Patch openings in and through concrete and masonry with grout.
 4. Restore new or existing work that is cut and/or damaged to original condition. Patch and repair specifically where existing items have been removed. This includes repairing and painting walls, ceilings, etc. where existing conduit and devices are removed as part of this project. Where alterations disturb lawns, paving, and/or walks, surfaces to be repaired, refinished and left in condition matching existing prior to commencement of work.
 5. Additional work required by lack of proper coordination will be provided at no additional cost to the Owner.

3.5 EQUIPMENT SELECTION AND SERVICEABILITY

- A. Replace or reposition equipment which is too large or located incorrectly to permit servicing, at no additional cost to Owner.

3.6 DELIVERY, STORAGE AND HANDLING

- A. Confirm requirements in Division 00, Procurement and Contracting Requirements and Division 01, General Requirements. In the absence of specific requirements, comply with individual Division 26, Electrical Sections and the following:
1. Handle materials delivered to project site with care to avoid damage. Store materials on site inside building or protected from weather, dirt and construction dust. Products and/or materials that become damaged due to water, dirt, and/or dust as a result of improper storage and handling to be replaced before installation.
 2. Protect equipment to avoid damage. Close conduit openings with caps or plugs. Keep motors and bearings in watertight and dustproof covers during entire course of installation.
 3. Protect bus duct and similar items until in service.

3.7 DEMONSTRATION

- A. Confirm Demonstration requirements in Division 00, Procurement and Contracting Requirements, Division 01, General Requirements, and individual Division 26, Electrical Sections.
 - 1. Also confirm Demonstration requirements in Section 26 08 00, Commissioning of Electrical.
- B. Upon completion of work and adjustment of equipment, test systems and demonstrate to Owner's Authorized Representative, Architect, and Engineer that equipment furnished and installed or connected under provisions of these Specifications functions in manner required. Provide field instruction to Owner's Maintenance Staff as specified in Division 01, General Requirements, Section 26 00 00, Electrical Basic Requirements and individual Division 26, Electrical Sections.
- C. Manufacturer's Field Services: Furnish services of a qualified person at time approved by Owner, to instruct maintenance personnel, correct defects or deficiencies, and demonstrate to satisfaction of Owner that entire system is operating in satisfactory manner and complies with requirements of other trades that may be required to complete work. Complete instruction and demonstration prior to final job site observations.
- D. Training and Demonstration per Section 01 91 13, General Commissioning Requirements and 26 08 00, Commissioning of Electrical.

3.8 CLEANING

- A. Confirm Cleaning requirements in Division 01, General Requirements, Section 26 00 00, Electrical Basic Requirements and individual Division 26, Electrical Sections.
- B. Upon completion of installation, thoroughly clean electrical equipment, removing dirt, debris, dust, temporary labels and traces of foreign substances. Throughout work, remove construction debris and surplus materials accumulated during work.

3.9 INSTALLATION

- A. Confirm Installation requirements in Division 00, Procurement and Contracting Requirements and Division 01, General Requirements, Section 26 00 00, Electrical Basic Requirements and individual Division 26, Electrical Sections.
- B. Install equipment and fixtures in accordance with manufacturer's installation instructions, plumb and level and firmly anchored to vibration isolators. Maintain manufacturer's recommended clearances.
- C. Start up equipment, in accordance with manufacturer's start-up instructions, and in presence of manufacturer's representative. Test controls and demonstrate compliance with requirements. Replace damaged or malfunctioning controls and equipment.
- D. Provide miscellaneous supports/metals required for installation of equipment.

3.10 PAINTING

- A. Confirm requirements in Division 01, General Requirements and Division 09, Finishes. In the absence of specific requirements, comply with individual Division 26, Electrical Sections and the following:
1. Ferrous Metal: After completion of work, thoroughly clean and paint exposed supports constructed of ferrous metal surfaces (i.e., hangers, hanger rods, equipment stands, etc.) with one coat of black asphalt varnish for exterior or black enamel for interior, suitable for hot surfaces.
 2. In Electrical Room, on roof or other exposed areas, equipment not painted with enamel to receive two coats of primer and one coat of rustproof enamel, colors as selected by Architect.
 3. See individual equipment Specifications for other painting.
 4. Structural Steel: Repair damage to structural steel finishes or finishes of other materials damaged by cutting, welding or patching to match original.
 5. Conduit: Clean, primer coat and paint interior/exterior conduit exposed in public areas with two coats paint suitable for metallic surfaces. Color selected by Architect.
 6. Covers: Covers such as manholes, vaults and the like will be furnished with finishes which resist corrosion and rust.

3.11 DEMOLITION

- A. Confirm requirements in Division 01, General Requirements and Division 02, Existing Conditions. In the absence of specific requirements, comply with individual Division 26, Electrical Sections and the following:
1. It is the intent of these documents to provide necessary information and adjustments to electrical system required to meet code, and accommodate installation of new work.
 2. Coordinate with Owner so that work can be scheduled not to interrupt operations, normal activities, building access or access to different areas. Owner will cooperate to best of their ability to assist in coordinated schedule, but will remain final authority as to time of work permitted.
 3. Examination:
 - a. Determine exact location of existing utilities and equipment before commencing work, compensate Owner for damages caused by failure to locate and preserve utilities. Replace damaged items with new material to match existing.
 - b. Verify that abandoned wiring and equipment serve only abandoned facilities.
 - c. Demolition drawings are based on casual field observation and existing record documents.
 - 1) Verify accuracy of information shown prior to bidding and provide such labor and material as is necessary to accomplish work.
 - 2) Verify location and number of electrical outlets, luminaires, panels, etc. in field.
 - d. Report discrepancies to Architect before disturbing existing installation.
 - 1) Promptly notify Owner if utilities are found which are not shown on Drawings.
 4. Execution:
 - a. Remove existing luminaires, switches, receptacles, and other electrical equipment and devices and associated wiring from walls, ceilings, floors, and other surfaces

- scheduled for remodeling, relocation, or demolition unless shown as retained or relocated on Drawings.
- b. Provide temporary wiring and connections to maintain electrical continuity of existing systems during construction. Remove or relocate electrical boxes, conduit, wiring, equipment, and luminaires, as encountered in removed or remodeled areas in existing construction affected by this work.
 - c. Remove and restore wiring which serves usable existing outlets clear of construction or demolition.
 - d. If existing junction boxes will be made inaccessible, or if abandoned outlets serve as feed through boxes for other existing electrical equipment which is being retained, provide new conduit and wire to bypass inaccessible junction boxes and abandoned outlets.
 - e. If existing conduits pass through partitions or ceiling which are being removed or remodeled, provide new conduit and wire to reroute clear of construction or demolition and maintain service to existing load.
 - f. Extend circuiting and devices in existing walls to be furred out.
 - g. Remove abandoned wiring to source of supply.
 - h. Remove exposed abandoned conduit, including abandoned conduit above accessible ceiling finishes. Cut conduit flush with walls and floors, and patch surfaces.
 - i. Disconnect abandoned outlets and remove devices. Remove abandoned outlets if conduit servicing them is abandoned and removed. Provide blank cover for abandoned outlets which are not removed.
 - j. Disconnect and remove abandoned panelboards and distribution equipment.
 - k. Disconnect and remove electrical devices and equipment serving utilization equipment that has been removed.
 - l. Existing lighting which is to remain, leave luminaires in proper working order.
 - m. Repair adjacent construction and finishes damaged during demolition work.
 - n. Maintain access to existing electrical installations which remain active. Modify installation or provide access panel as appropriate.

3.12 ACCEPTANCE

- A. Confirm requirements in Division 00, Procurement and Contracting Requirements and Division 01, General Requirements. In the absence of specific requirements, comply with individual Division 26, Electrical Sections and the following:
 1. System cannot be considered for acceptance until work is completed and demonstrated to Architect that installation is in strict compliance with Specifications, Drawings and manufacturer's installation instructions, particularly in reference to following:
 - a. Cleaning
 - b. Operation and Maintenance Manuals
 - c. Training of Operating Personnel
 - d. Record Drawings
 - e. Warranty and Guaranty Certificates
 - f. Start-up/Test Document and Commissioning Reports

3.13 FIELD QUALITY CONTROL

- A. Confirm Field Quality Control requirements in Division 01, General Requirements, Section 26 00 00, Electrical Basic Requirements and individual Division 26, Electrical Sections.

- B. Tests:
1. Conduct tests of equipment and systems to demonstrate compliance with requirements specified. Reference individual Specification Sections for required tests. Document tests and include in operation and maintenance manuals.
 2. During site evaluations by Architect or Engineer, provide appropriate personnel with tools to remove and replace trims, covers, and devices so that proper evaluation of installation can be performed.

3.14 LETTER OF CONFORMANCE

- A. Provide Letter of Conformance, copies of manufacturers' warranties and extended warranties with a statement that Electrical items were installed in accordance with manufacturer's recommendations, UL listings and FM Global approvals. Include Letter of Conformance, copies of manufacturers' warranties and extended warranties in Operation and Maintenance Manuals.

3.15 SALVAGED EQUIPMENT AND RECYCLED MATERIAL

- A. Salvage the following equipment not being reused and return to Owner:
1. Luminaires
 2. Panelboards
 3. Breakers
 4. Transformers
- B. Electrical equipment that cannot be salvaged for reuse, sell/give to recycling company. Recycle following excess, removed, or demolished electrical material:
1. Copper or aluminum conductors, buses, and motor/transformer windings.
 2. Steel and aluminum from raceways, boxes, enclosures, and housings.
 3. Acrylic and glass from luminaire lenses/refractors.
- C. Provide separate on-site storage space for recycled and salvaged material. Clearly label space.
- D. Confirm additional salvaged equipment and recycled materials in the Contract Documents.

END OF SECTION

SECTION 26 0509 - EQUIPMENT WIRING

PART 1 - GENERAL

1.1 SUMMARY

A. Work Included:

1. Equipment connections, whether furnished by Owner or other Divisions of the Contract.

1.2 RELATED SECTIONS

- A. Contents of Division 26, Electrical and Division 01, General Requirements apply to this Section.

1.3 REFERENCES AND STANDARDS

- A. References and Standards as required by Section 26 00 00, Electrical Basic Requirements and Division 01, General Requirements.

1.4 SUBMITTALS

- A. Submittals as required by Section 26 00 00, Electrical Basic Requirements and Division 01, General Requirements.

B. In addition:

1. Verify mechanical and utilization equipment electrical characteristics with Drawings and equipment submittals prior to ordering equipment. Submit confirmation of this verification as a part of, or addendum to, the electrical product submittals.

1.5 QUALITY ASSURANCE

- A. Quality assurance as required by Section 26 00 00, Electrical Basic Requirements and Division 01, General Requirements apply to this Section.

1.6 WARRANTY

- A. Warranty of materials and workmanship as required by Section 26 00 00, Electrical Basic Requirements and Division 01, General Requirements.

PART 2 - PRODUCTS

2.1 MATERIALS

- A. Materials and Equipment for Equipment Wiring: As specified in individual Sections.

2.2 GENERAL

- A. Unless otherwise noted, the following voltage and phase characteristics apply to motors:

1. 3/4 HP and Under: 120 volt, 1 phase.
2. 1 HP and Less than 5 HP Loads: 480 volt, 3 phase.
3. 5 HP and Over: 480 volt, 3 phase.

PART 3 - EXECUTION

3.1 EXAMINATION

- A. Prior to submittal of product data for electrical distribution equipment, obtain and examine product data and shop drawings for equipment furnished by the Owner and by other trades on the project. Update the schedule of equipment electrical connections accordingly, noting proper ratings for overcurrent devices, fuses, safety disconnect switches, conduit and wiring, and the like. As a minimum, this requirement applies to equipment furnished by Owner and equipment furnished under the following divisions of work under this contract:
1. Division 8, Openings
 2. Division 11, Equipment
 3. Division 14, Conveying Equipment
 4. Division 21, Fire Suppression
 5. Division 22, Plumbing
 6. Division 23, HVAC, Heating, Ventilating and Air Conditioning
 7. Division 27, Communications
 8. Division 28, Electronic Safety and Security

3.2 INSTALLATION

- A. Do not install unrelated electrical equipment or wiring on mechanical equipment without prior approval of Engineer.
- B. Provide moisture tight equipment wiring and switches in ducts or plenums used for environmental air.
- C. Connect motor and appliance/utilization equipment complete from panel to motor/equipment as required by code.
- D. Install motor starters and controllers for equipment furnished by others.
- E. Appliance/Utilization Equipment:
1. Provide appropriate cable and cord cap for final connection unless equipment is provided with same. Provide receptacle configured to receive cord cap.
 2. Verify special purpose outlet NEMA configuration and ampere rating with equipment supplier prior to ordering wiring devices and coverplates.

3.3 FIELD QUALITY CONTROL

- A. Perform field inspection and testing in accordance with Division 01, General Requirements.

3.4 SYSTEMS STARTUP

- A. Provide field representative to prepare and start equipment.
1. Test and correct for proper rotation of polyphase motors.
- B. Adjust for proper operation within manufacturer's published tolerances.

- C. Demonstrate proper operation of equipment to Owner's Authorized Representative.

END OF SECTION

SECTION 26 0519 - LOW-VOLTAGE ELECTRICAL POWER CONDUCTORS AND CABLES

PART 1 - GENERAL

1.1 SUMMARY

- A. Work Included:
 - 1. Lugs and Pads
 - 2. Wires and Cables
 - 3. Connectors

1.2 RELATED SECTIONS

- A. Contents of Division 26, Electrical and Division 01, General Requirements apply to this Section.

1.3 REFERENCES AND STANDARDS

- A. References and Standards as required by Section 26 00 00, Electrical Basic Requirements and Division 01, General Requirements.

1.4 SUBMITTALS

- A. Submittals as required by Section 26 00 00, Electrical Basic Requirements and Division 01, General Requirements.
- B. In addition, provide:
 - 1. Cable insulation test reports in project closeout documentation.

1.5 QUALITY ASSURANCE

- A. Quality assurance as required by Section 26 00 00, Electrical Basic Requirements and Division 01, General Requirements.

1.6 WARRANTY

- A. Warranty of materials and workmanship as required by Section 26 00 00, Electrical Basic Requirements and Division 01, General Requirements.

PART 2 - PRODUCTS

2.1 MANUFACTURERS

- A. Lugs and Pads:
 - 1. Anderson
 - 2. IlSCO
 - 3. Panduit
 - 4. Thomas & Betts
 - 5. 3M
 - 6. Or approved equivalent.

- B. Wires and Cables:
 - 1. General:
 - a. General Cable
 - b. Okonite
 - c. Southwire
 - d. Encore Wire
 - e. Or approved equivalent.
 - 2. Metal Clad Cable - Type MC:
 - a. Alflex
 - b. AFC
 - c. General Cable
 - d. Southwire
 - e. Encore Wire
 - f. Or approved equivalent.

- C. Connectors:
 - 1. Anderson Power Products
 - 2. Burndy
 - 3. IlSCO
 - 4. 3M
 - 5. Thomas & Betts
 - 6. Or approved equivalent.

2.2 LUGS AND PADS

- A. Ampacity: Cross-sectional area of pad for multiple conductor terminations to match ampere rating of panelboard bus or equipment line terminals.
- B. Copper Pads: Drilled and tapped for multiple conductor terminals.
- C. Lugs: Compression type for use with stranded branch circuit or control conductors; mechanical lugs for use with solid branch and feeder circuit conductors.

2.3 WIRES AND CABLES

- A. Building Wires:
 - 1. Copper: Soft-drawn with conductivity of not less than 98 percent IACS at 20 degrees C (68 degrees F). 600 volt rated throughout. Conductors 12 AWG and 10 AWG, solid. Conductors 8 AWG and larger, stranded. 12 AWG minimum conductor size. Minimum insulation rating of 90 degrees C. Insulation Type: THHN/THWN-2.
- B. Phase color to be consistent at feeder terminations; A-B-C, top to bottom, left to right, front to back.
- C. Color Code Conductors as Follows:

PHASE	208 VOLT WYE	240 VOLT DELTA	480 VOLT
A	Black	Black	Brown
B	Red	Orange (High Leg)	Orange

C	Blue	Blue	Yellow
Neutral	White	White	Gray or White w/colored strip
Ground	Green	Green	Green
Isolated Ground	Green w/yellow trace	N/A	N/A

D. MC Cable:

1. Standard: High strength galvanized steel flexible armor. Full length minimum size No. 12 copper ground wire, copper dual rated THHN/THWN-2, full length tape marker phase/circuit identification on cable armor. Short circuit throat insulators, mechanical compression termination.

E. AC Cable (Armored Cable): Not allowed.

F. NMB Cable: Not allowed.

2.4 CONNECTORS

A. Split bolt connectors not allowed.

B. Conductor Branch Circuits: Wire nuts with integral spring connectors for conductors 12 AWG through 8 AWG. Push-in type connectors where conductors are not required to be twisted together are not acceptable.

PART 3 - EXECUTION

3.1 GENERAL INSTALLATION REQUIREMENTS

A. Install per manufacturer instructions and NEC.

B. Field Quality Control:

1. Test conductor insulation on feeders of 100 amp and greater for conformity with 1000 volt megohmmeter. Use Insulated Cable Engineers Association testing procedures. Minimum insulation resistance acceptable is 1 megohm for systems 600 volts and below. Notify Architect if insulation resistance is less than 1 megohm.
2. Test Report: Prepare a typed tabular report indicating the testing instrument, the feeder tested, amperage rating of the feeder, insulation type, voltage, the approximate length of the feeder, conduit type, and the measured resistance of the megohmmeter test. Submit test reports with project closeout documents.
3. Inspect and test in accordance with NETA Standard ATS, except Section 4.
4. Perform inspections and tests listed in NETA Standard ATS, Section 7.3.2.

3.2 LUGS AND PADS

A. Thoroughly clean surfaces to remove all dirt, oil, grease or paint.

B. Use torque wrench to tighten per manufacturer's directions.

3.3 WIRES AND CABLES

A. General:

1. Do not install or handle thermoplastic insulated wire and cable in temperatures below -10 degrees C (14 degrees F). Do not handle thermoset insulated wire and cable in temperatures below -40 degrees C (-40 degrees F). All wire and cable must be acclimated to temperatures above freezing for no less than 24 hours prior to installation.
2. Install conductors in raceways having adequate, code size cross-sectional area for wires indicated.
3. Install conductors with care to avoid damage to insulation.
4. Do not apply greater tension on conductors than recommended by manufacturer during installation.
5. Use of pulling compounds is permitted. Clean residue from exposed conductors and raceway entrances after conductor installation. Do not use pulling compounds for installation of conductors connected to GFCI circuit breakers or GFCI receptacles.
6. Conductor Size and Quantity:
 - a. Install no conductors smaller than 12 AWG unless otherwise shown.
 - b. Provide required conductors for a fully operable system.
 - c. Power Circuits: No. 12 AWG minimum, except as follows:
 - 1) No. 10 AWG for 15A, 120V circuits longer than 100 ft.
 - 2) No. 8 AWG for 15A, 120V circuits longer than 150 ft.
 - 3) No. 10 AWG for 20A, 120V circuits longer than 70 ft.
 - 4) No. 8 AWG for 20A, 120V circuits longer than 100 ft.
 - d. When exact run lengths are determined for all branch circuits, and prior to installation of the conductors, ensure that the maximum voltage drop, based on 80 percent of the circuit protective device, does not exceed 3 percent. Increase wire size from #12AWG, if necessary, to ensure that the 3 percent voltage drop is not exceeded.
7. Provide dedicated neutrals (one neutral conductor for each phase conductor) in all 120V circuits.

B. Conductors in Cabinets:

1. Cable and tree wires in panels and cabinets for power and control. Use plastic ties in panels and cabinets.
2. Tie and bundle feeder conductors in wireways of panelboards.
3. Hold conductors away from sharp metal edges.

C. Homeruns:

1. Do not change intent of branch circuit homeruns without approval. Homeruns for 20A branch circuits may be combined to a maximum of six current carrying conductors including neutral conductors in homeruns. Apply derating factors as required per NEC. Increase conductor size as needed.
2. MC cable homeruns are not allowed unless indicated on drawings.

D. Identify wire and cable under the provisions of Section 26 05 53, Identification for Electrical Systems. Identify each conductor with its panel and circuit number as indicated.

E. Exposed cable is not allowed.

- F. All cable must be run parallel or perpendicular to building lines and hidden from view when possible. Where installed in tray each power cable is to be identified with Lamacoid nametag engraved with identification of equipment being fed. Tag to be fastened to cable using tie-wraps. Provide nametag at each floor level.
- G. Do not install PVC jacketed cables in return air plenums, unless they are specially rated plenum cables.
- H. Use of MC Cable is limited to the following conditions. Installations that do not comply with the following conditions are to be removed and replaced with no additional expense to the Owner.
 - 1. 15 and 20 amp branch wiring where following conditions apply:
 - a. MC cable is allowed for branch circuits, including both lighting and power outlets, as allowed by code and restricted below.
 - b. Use MC cable for final flexible connections from junction or outlet boxes to recessed fixtures. Do not use MC cables to loop between fixtures, except where it is not practical to provide conduit connections between boxes or where existing inaccessible ceilings prevent installation of conduit runs. Each individual luminaire is to be serviced by an individual cable drop from the associated junction box in the ceiling space. Maximum length 6-feet of MC cable. Luminaire drops secured to, and supported by, the building structure with nylon tie wraps. The use of the ceiling suspension system for support of any type of cabling is not permitted.
 - c. MC cable may be routed in the void space above hard lid ceilings, and routed within wall cavities below glazing, provided NEC requirements are otherwise met, and a minimum one 0.75-inch conduit is routed from nearest accessible ceiling space to inaccessible location, terminating in a j-box with blank faceplate, for future circuits.

3.4 CONNECTORS

- A. Install to assure a solid and safe connection.
- B. Select hand twist connectors for wire size and install tightly on conductors.
- C. Install compression connectors using methods and tools recommended by the manufacturer.
- D. Do not install stranded conductors under screw terminals unless compression lugs are installed.
- E. Do not connect wiring without UL listed connectors that are listed for the purposes.

END OF SECTION

SECTION 26 0526 - GROUNDING AND BONDING FOR ELECTRICAL SYSTEMS

PART 1 - GENERAL

1.1 SUMMARY

- A. Work Included:
 - 1. Grounding Electrodes
 - 2. Connectors and Accessories
 - 3. Grounding Busbar
 - 4. Grounding Conductor

1.2 RELATED SECTIONS

- A. Contents of Division 26, Electrical and Division 01, General Requirements apply to this Section.

1.3 REFERENCES AND STANDARDS

- A. References and Standards as required by Section 26 00 00, Electrical Basic Requirements and Division 01, General Requirements.

1.4 SUBMITTALS

- A. Submittals as required by Section 26 00 00, Electrical Basic Requirements and Division 01, General Requirements.
- B. In addition, provide:
 - 1. Test reports of ground resistance for service and separately derived system grounds.

1.5 QUALITY ASSURANCE

- A. Quality assurance as required by Section 26 00 00, Electrical Basic Requirements and Division 01, General Requirements.
- B. In addition, meet the following:
 - 1. Comply with the requirements of ANSI/NFPA 70.

1.6 WARRANTY

- A. Warranty of materials and workmanship as required by Section 26 00 00, Electrical Basic Requirements and Division 01, General Requirements.

PART 2 - PRODUCTS

2.1 MANUFACTURERS

- A. Grounding Electrodes:
 - 1. Erico
 - 2. Thomas & Betts
 - 3. Talley

4. Or approved equivalent.

B. Connectors and Accessories:

1. Burndy Hyground Compression System
2. Erico/Cadweld
3. Amp Ampact Grounding System
4. Pipe Grounding Clamp:
 - a. Burndy GAR Series
 - b. O Z Gedney
 - c. Thomas & Betts
 - d. Or approved equivalent.

C. Grounding Busbar:

1. Chatsworth
2. Erico
3. Schneider Electric/Square D
4. Panduit
5. Or approved equivalent.

D. Grounding Conductor

1. General Cable
2. Okonite
3. Southwire
4. Or approved equivalent

2.2 GROUNDING ELECTRODES

- A. Ground Rods: Copper-clad steel, minimum 3/4-inch diameter, 10-feet long, tapered point, chamfered top.

2.3 CONNECTORS AND ACCESSORIES

- A. Grounding Connectors: Hydraulic compression tool applied connectors or exothermic welding process connectors or powder actuated compression tool applied connectors.
- B. Pipe Grounding Clamp: Mechanical ground connector with cable parallel or perpendicular to pipe.

2.4 GROUNDING BUSBAR

- A. Grounding Busbar: 1/4-inch thick by 4-inch high by 10-inch long copper grounding busbar with insulators that meet ANSI J-STD-607-A specifications. UL 467 listed. Hole patterns in busbar to accommodate two-hole lugs, four-hole configuration.

2.5 GROUNDING CONDUCTOR

- A. Grounding Electrode Conductor: Soft-draw bare stranded copper for wire sizes larger than #10 AWG Bare. Solid copper for wire sizes #10 AWG and smaller.

- B. Equipment Grounding Conductor: Green insulated, insulation type to match that of associated feeder or branch circuit wiring, size as indicated on drawings.

PART 3 - EXECUTION

3.1 GENERAL INSTALLATION REQUIREMENTS

- A. Verify site conditions prior to beginning work.
- B. Bond Sections of service equipment enclosure to service ground bus.
- C. Separately Derived Systems: Ground each separately derived system per NEC Article 250.
- D. Corrosion inhibitors: Apply a corrosion inhibitor to contact surfaces when making grounding and bonding connections. Use corrosion inhibitor appropriate for protecting a connection between metals used.
- E. Grounding system resistance to ground not to exceed 5 ohms. Make necessary modifications or additions to grounding electrode system for compliance. Submit final tests to assure that this requirement is met.
- F. Resistance of grounding electrode system: measure using a four-terminal fall-of-potential method as defined in IEEE 81. Take ground resistance measurements before electrical distribution system is energized and in normally dry conditions, not less than 48 hours after last rainfall. Take resistance measurements of separate grounding electrode systems before systems are bonded together below grade. Combined resistance of separate systems may be used to meet required resistance, but specified number of electrodes must still be provided.
- G. Inspect and test in accordance with NETA Standard ATS, Except Section 4.
- H. Perform inspections and tests listed in NETA Standard AB, Section 7.13.

3.2 GROUNDING ELECTRODES INSTALLATION

- A. Concrete-Encased Electrode (“Ufer Ground”):
 - 1. From service equipment ground bus provide grounding electrode conductor to footing/foundation rebar.
 - 2. Bond #4 grounding electrode conductor to one minimum 20-foot long, 3/4-inch diameter independent steel rebar(s).
 - 3. Protect grounding electrode conductor from footing/foundation to service equipment grounding bus with rigid PVC conduit where grounding electrode conductor passes through concrete floor or other concrete structure. Do not use rigid metal conduit for grounding electrode conductor protection.
 - 4. Coordinate bonding of rebar in base of building concrete footing with installer prior to placement of concrete.
- B. Ground Rod Electrode:
 - 1. Verify that final backfill and compaction have been completed before driving rod electrodes.
 - 2. Bond #6 grounding electrode conductor to driven ground rods as indicated on Drawings.

3. Tap at center ground rod and extend grounding electrode conductor to service grounding bus. Install grounding electrode conductor to service grounding bus in rigid PVC conduit for physical protection where grounding electrode conductor passes through concrete floor or other concrete structure.
 - C. Metal Underground Water Service: Bond water service pipe to service equipment ground bus or to the grounding electrode system. Connect to water pipe on utility side of isolating fittings or meters, bond across water meters.
 - D. Other Metal Piping Systems: Bond gas piping system, fire sprinkler piping system and other metal piping systems to service equipment ground bus or to the grounding electrode system.
 - E. Bond together metal siding not attached to grounded structure; bond to grounding electrode system.
- 3.3 CONNECTORS AND ACCESSORIES INSTALLATION
- A. Install per manufacturer's instructions.
- 3.4 GROUNDING BUSBAR INSTALLATION
- A. Install per manufacturer's instructions.
- 3.5 GROUNDING CONDUCTOR INSTALLATION
- A. Raceways:
 1. Ground metallic raceway systems. Bond to ground terminal with code size jumper except where code size or larger equipment grounding conductor is included with circuit, use grounding bushing with lay-in lug.
 2. Connect metal raceways, which terminate within an enclosure but without mechanical connection to enclosure, by grounding bushings and ground conductor to grounding bus.
 3. Where equipment supply conductors are in flexible metallic conduit, install stranded copper equipment grounding conductor from outlet box to equipment frame.
 4. Install equipment grounding conductor, code size minimum unless noted on drawings, in metallic and nonmetallic raceway systems.
 - B. Feeders and Branch Circuits:
 1. Provide continuous green insulated copper equipment grounding conductors for feeders and branch circuits.
 2. Where installed in a continuous solid metallic raceway system and larger sizes are not detailed, provide insulated equipment grounding conductors for feeders and branch circuits sized in accordance with the latest adopted edition of NEC Article 250, Table 250-122.
 - C. Bond boxes, cabinets, enclosures and panelboard equipment grounding conductors to enclosure with specified conductors and lugs. Install lugs only on thoroughly cleaned contact surfaces.
 - D. Motors, Equipment and Appliances: Install code size equipment grounding conductor to (motor) equipment frame or manufacturer's designated ground terminal.

- E. Receptacles: Connect ground terminal of receptacle and associated outlet box to equipment grounding conductor. Self grounding nature of receptacle devices does not eliminate equipment grounding conductor bolted to outlet box.

END OF SECTION

SECTION 26 0529 - HANGERS AND SUPPORTS FOR ELECTRICAL SYSTEMS AND EQUIPMENT

PART 1 - GENERAL

1.1 SUMMARY

- A. Work Included:
 - 1. Anchors, Threaded Rod and Fasteners
 - 2. Support Channel, Hangers and Supports
 - 3. Rooftop Conduit Supports

1.2 RELATED SECTIONS

- A. Contents of Division 26, Electrical and Division 01, General Requirements apply to this Section.

1.3 REFERENCES AND STANDARDS

- A. References and Standards as required by Section 26 00 00, Electrical Basic Requirements and Division 01, General Requirements.

1.4 SUBMITTALS

- A. Submittals not required for this Section.

1.5 QUALITY ASSURANCE

- A. Quality assurance as required by Section 26 00 00, Electrical Basic Requirements and Division 01, General Requirements.
- B. In addition, meet the following:
 - 1. Manufacturers regularly engaged in the manufacture of bolted metal framing support systems, whose products have been in satisfactory use in similar service for not less than 10 years.
 - 2. Support systems to be supplied by a single manufacturer.
 - 3. Engineering Responsibility: Design and preparation of Shop Drawings and calculations for each multiple pipe support, trapeze, equipment hangers/supports, and seismic restraint by a qualified Structural Professional Engineer.
 - a. Professional Engineer Qualifications: A professional engineer who is legally qualified to practice in jurisdiction where Project is located and who is experienced in providing engineering services of the kind indicated. Engineering services are defined as those performed for installations of hangers and supports that are similar to those indicated for this Project in material, design, and extent.

1.6 WARRANTY

- A. Warranty of materials and workmanship as required by Section 26 00 00, Electrical Basic Requirements and Division 01, General Requirements.

1.7 PERFORMANCE REQUIREMENTS

- A. General: Provide conduit and equipment hangers and supports in accordance with the following:
 - 1. When supports, anchorages, and seismic restraints for equipment and supports, anchorages and seismic restraints for conduit, cable tray and equipment are not shown on the Drawings, the Contractor is responsible for their design.
 - 2. Connections to structural framing shall not introduce twisting, torsion, or lateral bending in the framing members. Provide supplementary steel as required.
- B. Engineered Support Systems: The following support systems to be designed, detailed, and bear the seal of a professional engineer registered in the State of Virginia.
 - 1. Support frames such as conduit racks or stanchions for conduit and equipment which provide support from below.
 - 2. Equipment and piping support frame anchorage to supporting slab or structure.
- C. Provide channel support systems, for conduits to support multiple conduits capable of supporting combined weight of support systems and system contents.
- D. Provide heavy-duty steel trapezes for piping to support multiple conduit capable of supporting combined weight of supported systems and system contents.
- E. Obtain approval from AHJ for seismic restraint hanger and support system to be installed for piping and equipment.

PART 2 - PRODUCTS

2.1 MANUFACTURERS

- A. Anchors, Threaded Rod and Fasteners:
 - 1. Anchor It
 - 2. Epcon System
 - 3. Hilti-Hit System
 - 4. Power Fast System
 - 5. Or approved equivalent.
- B. Support Channel, Hangers and Supports:
 - 1. B-Line
 - 2. Kindorf
 - 3. Superstrut
 - 4. Unistrut
 - 5. Or approved equivalent.
- C. Rooftop Conduit Supports:
 - 1. Cooper B-Line Dura-Block Rooftop Support Base
 - 2. Or approved equivalent.

2.2 ANCHORS, THREADED ROD AND FASTENERS

- A. Anchors, Threaded Rod and Fasteners - General: Corrosion-resistant materials of size and type adequate to carry the loads of equipment and conduit, including weight of wire in conduit.
- B. Concrete Inserts: Cast in concrete for support fasteners for loads up to 800 lbs.
- C. Anchors and Fasteners:
 - 1. Do not use powder-actuated anchors.
 - 2. Concrete Structural Elements: Use precast inserts.
 - 3. Steel Structural Elements: Use beam clamps.
 - 4. Concrete Surfaces: Use self-drilling anchors.
 - 5. Hollow Masonry, Plaster, and Gypsum Board Partitions: Use toggle bolts.
 - 6. Solid Masonry Walls: Use expansion anchors.
 - 7. Sheet Metal: Use sheet metal screws.
 - 8. Wood Elements: Use wood screws.
- D. Fasteners: Provide fasteners of types as required for assembly and installation of fabricated items; surface-applied fasteners are specified elsewhere.
- E. Bolts: Low carbon steel externally and internally threaded fasteners conforming with requirements of ASTM A307; include necessary nuts and plain hardened washers. For structural steel elements supporting mechanical material or equipment from building structural members or connection thereto, use fasteners conforming to ASTM A325.
- F. Miscellaneous Materials: Provide incidental accessory materials, tools, methods, and equipment required for fabrication.

2.3 SUPPORT CHANNEL, HANGERS AND SUPPORTS

- A. Hangers and Supports - General: Corrosion-resistant materials of size and type adequate to carry the loads of equipment and conduit, including weight of wire in conduit.
 - 1. Channel Material: Carbon steel.
 - 2. Coating: Hot dip galvanized.
- B. Pipe Straps: Two-hole galvanized or malleable iron.
- C. Luminaire Chain: 90 lb. test with steel hooks.
- D. Miscellaneous Metal: Provide miscellaneous metal items specified hereunder, including materials, fabrication, fastenings and accessories required for finished installation, where indicated on Drawings or otherwise not shown on drawings that are necessary for completion of the project. The Contractor is responsible for their design.
 - 1. Fabricate miscellaneous units to size shapes and profiles indicated or, if not indicated, of required dimensions to receive adjacent other work to be retained by framing. Except as otherwise shown, fabricate from structural steel shapes and plates and steel bars, of welded construction using mitered joints for field connection. Cut, drill and tap units to receive hardware and similar items.

- E. Structural Shapes: Where miscellaneous metal items are needed to be fabricated from structural steel shapes and plates, provide members constructed of steel conforming with requirements of ASTM A36 or approved equivalent.
- F. Steel Pipe: Provide seamless steel pipe conforming to requirements of ASTM A53, Type S, Grade A, or Grade B. Weight and size required as specified.
- G. Miscellaneous Materials: Provide incidental accessory materials, tools, methods, and equipment required for fabrication.

2.4 ROOFTOP CONDUIT SUPPORTS

- A. Curb base made of 100 percent recycled rubber and polyurethane prepolymer with a uniform load
- B. Capacity of 500 pounds per linear foot of support.
- C. UV resistant.
- D. Steel Frame: Steel, 14 gauge strut galvanized per ASTM A653 or 12 gauge strut galvanized per ASTM A653 for bridge series.
- E. Continuous block channel supports with 1-inch gaps to allow water flow, bridge channel supports, extendable height channel supports and elevated single conduit supports.
- F. Attaching Hardware: Zinc-plated threaded rod, nuts and attaching hardware per ASTM B633 fastened directly into rubber material with weather resistant Type 12 lag screws.
- G. Provide load distribution plates when required for heavy loads.
- H. Finish: Black with safety yellow striping.
- I. Provide hot dipped galvanized components for items exposed to weather.

PART 3 - EXECUTION

3.1 GENERAL INSTALLATION REQUIREMENTS

- A. Fabrication - Miscellaneous Metals
 - 1. General: Verify dimensions prior to fabrication. Form metal items to accurate sizes and configurations as indicated on Drawings and otherwise required for proper installation; make with lines straight and angles sharp, clean and true; drill, countersink, tap, and otherwise prepare items for connections with work of other trades, as required. Fabricate to detail of structural shapes, plates and bars; weld joints where practicable; provide bolts and other connection devices required. Include anchorages; clip angles, sleeves, anchor plates, and similar devices. Hot dipped galvanize after fabrication items installed in exterior locations. Set accurately in position as required and anchor securely to building construction. Construct items with joints formed for strength and rigidity, accurately machining for proper fit; where exposed to weather, form to exclude water.
 - 2. Finishes:

- a. Ferrous Metal: After fabrication, but before erection, clean surfaces by mechanical or chemical methods to remove rust, scale, oil, corrosion, or other substances detrimental to bonding of subsequently applied protective coatings. For metal items exposed to weather or moisture, galvanize in manner to obtain G90 zinc coating in accordance with ASTM A123. Provide other non-galvanized ferrous metal with one coat of approved rust-resisting paint primer, in manner to obtain not less than 1.0 mil dry film thickness. Touch-up damaged areas in primer with same material, before installation. Apply zinc coatings and paint primers uniformly and smoothly; leave ready for finish painting as specified elsewhere.
- b. Metal in contact with Concrete, Masonry and Other Dissimilar Materials: Where metal items are to be erected in contact with dissimilar materials, provide contact surfaces with coating of an approved zinc-chromate primer in manner to obtain not less than 1.0 mil dry film thickness, in addition to other coatings specified in these specifications.
- c. For Galvanized Surfaces: Clean field welds, bolted connections, and abraded areas and apply galvanizing repair paint to comply with ASTM A780.

3.2 ANCHORS, THREADED ROD AND FASTENERS INSTALLATION

- A. Safety factor of 4 required for every fastening device or support for equipment installed. Supports to withstand four times the weight of equipment it supports.
- B. Do not use other trade's fastening devices as supporting means for luminaires, equipment or materials.
- C. Do not fasten supports to pipes, ducts, mechanical equipment, or conduit.
- D. Do not use supports or fastening devices to support other than one particular item.
- E. Securely suspend junction boxes, pull boxes or other conduit terminating housings located above suspended ceiling from floor above or roof structure to prevent sagging and swaying.
- F. Provide seismic bracing per IBC requirements.
- G. Install surface-mounted cabinets and panelboards with minimum of four anchors.
- H. Use spring lock washers under fastener nuts for strut.
- I. Cutting and Drilling
 1. Do not drill or cut structural members without prior permission from Architect.

3.3 SUPPORT CHANNEL, HANGERS AND SUPPORTS INSTALLATION

- A. Install hangers and supports as required to adequately and securely support electrical system components, in a neat and workmanlike manner, as specified in NECA 1.
- B. Safety factor of 4 required for every fastening device or support for equipment installed. Supports to withstand four times the weight of equipment it supports.
- C. Verify mounting height of luminaires prior to installation when heights are not detailed.

- D. Install vertical support members for equipment and luminaires, straight and parallel to building walls.
- E. Install horizontal support members straight and parallel to ceilings or finished floor unless otherwise noted.
- F. Provide independent supports to structural member for luminaires, materials, or equipment installed in or on ceiling, walls or in void spaces or over suspended ceilings.
- G. Do not use other trade's fastening devices as supporting means for luminaires, equipment or materials.
- H. Do not fasten supports to pipes, ducts, mechanical equipment, or conduit.
- I. Do not use supports or fastening devices to support other than one particular item.
- J. Support conduits within 18-inches of outlets, boxes, panels, cabinets and deflections unless more stringently required by NEC.
- K. Maximum distance between supports not to exceed 8 foot spacing unless otherwise required by NEC.
- L. Support flexible conduits and metal clad cable within 12-inches of outlets, boxes, panels, cabinets and deflections unless otherwise required by NEC.
- M. Maximum distance between supports for flexible conduits and metal clad cable not to exceed 48-inches spacing unless otherwise required by NEC.
- N. Maximum distance between supports for rigid PVC conduits unless otherwise required by NEC is as follows:
 - 1. 1/2-inch or 3/4-inch and 1-inch conduit, 3-feet apart.
 - 2. 1-1/4-inch or 1-1/2-inch and 2-inch conduit, 4-feet apart.
 - 3. 2-1/2-inch and 3-inch conduit, 5-feet apart.
 - 4. 4-inch and 5-inch conduit, 6-feet apart.
 - 5. 6-inch conduit, 7-feet apart.
- O. Maximum distance between supports for auxiliary gutters and wireways unless otherwise required by NEC is as follows:
 - 1. Sheet metal auxiliary gutters and wireways - 4-feet apart horizontally and 10-feet vertically.
 - 2. Non-metallic auxiliary gutters and wireways - 30-inches apart horizontally and 3-feet vertically.
- P. Install strut hangers as instructed by strut manufacturer. Suspend strut hangers as instructed by strut manufacturer for the load, with a maximum spacing of 8-feet on center and within 2-feet of outlet box, cabinet, junction box or other channel raceway termination unless otherwise required by NEC.

- Q. Coordinate routing of conduit racks with materials and equipment installed by other trades. Where conduit racks are exposed to view, coordinate location and installation with Architect for optimal appearance.
- R. Securely suspend junction boxes, pull boxes or other conduit terminating housings located above suspended ceiling from floor above or roof structure to prevent sagging and swaying.
- S. Provide seismic bracing per IBC requirements.
- T. Where service disconnects are mounted on building exterior, physically attach service disconnect to the building or structure served.
- U. Install surface-mounted cabinets and panelboards with minimum of four anchors.
- V. Use sheet metal channel to bridge studs above and below cabinets and panelboards recessed in hollow partitions.
- W. Wet and Damp Locations:
 - 1. In wet and damp locations use steel channel supports to stand cabinets and panelboards 1-inch off wall.

3.4 ROOFTOP CONDUIT SUPPORTS INSTALLATION

- A. Consult roofing manufacturer for roof membrane compression capacities. If necessary, provide a compatible sheet of roofing material (rubber pad) under rooftop support to disperse concentrated loads and add further membrane protection.
- B. Do not use supports that will void roof warranty.
- C. Install supports per manufacturer's instructions and recommendations.
- D. Use properly sized clamps to suit conduit sizes.
- E. Install supports for rooftop raceways to raise raceways a minimum of 7/8-inches above the roof structure unless otherwise noted.

END OF SECTION

SECTION 26 0533 - RACEWAYS

PART 1 - GENERAL

1.1 SUMMARY

- A. Work Included:
 - 1. Rigid Metal Conduit (RMC)
 - 2. Polyvinyl Chloride (PVC) Externally Coated Galvanized Rigid Metal Conduit
 - 3. Electrical Metallic Tubing (EMT)
 - 4. Flexible Metal Conduit (FMC)
 - 5. Liquidtight Flexible Metal Conduit (LFMC)
 - 6. Electrical Polyvinyl Chloride (PVC) Conduit
 - 7. Conduit Fittings

- B. Provide a complete system of conduit and fittings, with associated couplings, connectors, and fittings, as shown on drawings and described in these specifications.

1.2 RELATED SECTIONS

- A. Contents of Division 26, Electrical and Division 01, General Requirements apply to this Section.

- B. In addition, reference the following:
 - 1. Section 26 05 29, Hangers and Supports for Electrical Systems and Equipment
 - 2. Section 26 05 34, Boxes

1.3 REFERENCES AND STANDARDS

- A. References and Standards as required by Section 26 00 00, Electrical Basic Requirements and Division 01, General Requirements.

1.4 SUBMITTALS

- A. Submittals as required by Section 26 00 00, Electrical Basic Requirements and Division 01, General Requirements.

1.5 QUALITY ASSURANCE

- A. Quality assurance as required by Section 26 00 00, Electrical Basic Requirements and Division 01, General Requirements.

1.6 WARRANTY

- A. Warranty of materials and workmanship as required by Section 26 00 00, Electrical Basic Requirements and Division 01, General Requirements.

1.7 DEFINITIONS

- A. Raceway system is defined as consisting of conduit, tubing, duct, and fittings including but not limited to connectors, couplings, offsets, elbows, bushings, expansion/deflection fittings, and

other components and accessories. Complete electrical raceway installation before starting the installation of conductors and cables.

PART 2 - PRODUCTS

2.1 MANUFACTURERS

- A. Rigid Metal Conduit (RMC):
 - 1. Allied Tube & Conduit
 - 2. Beck Manufacturing Inc.
 - 3. Picoma
 - 4. Wheatland Tube Company
 - 5. Or approved equivalent.

- B. Polyvinyl Chloride (PVC) Externally Coated Galvanized Rigid Steel Conduit:
 - 1. Allied Tube & Conduit
 - 2. Thomas & Betts Corporation
 - 3. Robroy Industries
 - 4. O'kote Inc.
 - 5. Or approved equivalent.

- C. Electrical Metallic Tubing (EMT):
 - 1. Allied Tube & Conduit
 - 2. Beck Manufacturing WL
 - 3. Picoma
 - 4. Wheatland Tube Company
 - 5. Or approved equivalent.

- D. Flexible Metal Conduit (FMC):
 - 1. AFC Cable Systems Inc.
 - 2. Electri-Flex Company
 - 3. International Metal Hose
 - 4. Or approved equivalent.

- E. Liquidtight Flexible Metal Conduit (LFMC):
 - 1. AFC Cable Systems Inc.
 - 2. Electri-Flex Company
 - 3. International Metal Hose
 - 4. Or approved equivalent.

- F. Electrical Polyvinyl Chloride (PVC) Conduit:
 - 1. AFC Cable Systems Inc.
 - 2. Electri-Flex Company
 - 3. International Metal Hose
 - 4. JM Eagle
 - 5. Or approved equivalent.

- G. Conduit Fittings:
 - 1. Bushings:

- a. Insulated Type for Threaded Raceway Without Factory Installed Plastic Throat Conductor Protection:
 - 1) Thomas & Betts 1222 Series
 - 2) O-Z Gedney B Series
 - 3) Or approved Equivalent.
 - 2. Raceway Connectors and Couplings:
 - a. Thomas & Betts Series
 - b. O-Z Gedney Series
 - c. Or approved Equivalent.
 - 3. Expansion/Deflection Fittings:
 - a. EMT: O-Z Gedney Type TX
 - b. RMC: O-Z Gedney Type AX, DX and AXDX, Crouse & Hinds XD
 - c. PVC: O-Z Gedney Type DX with PVC adapters, Carlon E945 Series, Kraloy OPEJ Series
 - d. Or approved equivalent.
- 2.2 RIGID METAL CONDUIT (RMC)
- A. UL 6, ANSI C80.1. Hot dipped galvanized steel conduit after thread cutting.
 - 1. Fittings: NEMA FB2.10.
- 2.3 POLYVINYL CHLORIDE (PVC) EXTERNALLY COATED GALVANIZED RIGID METAL CONDUIT
- A. Description: UL 6, ANSI C80.1, and NEMA RN 1; rigid steel conduit with external PVC coating.
 - 1. PVC Coating: Minimum 40 mils in thickness.
 - B. Fittings and Conduit Bodies: NEMA FB 1; steel fittings with external PVC coating to match conduit.
- 2.4 ELECTRICAL METALLIC TUBING (EMT)
- A. Description: UL 797, ANSI C80.3; steel galvanized tubing.
 - B. Fittings: NEMA FB 1; steel, compression type.
- 2.5 FLEXIBLE METAL CONDUIT (FMC)
- A. Description: UL 1, Interlocked steel construction.
 - B. Fittings: NEMA FB 2.20.
- 2.6 LIQUIDTIGHT FLEXIBLE METAL CONDUIT (LFMC)
- A. Description: UL 360, inner core made from spiral wound strip of heavy gauge, hot dipped galvanized low carbon steel. 3/4-inch through 1-1/4-inch trade sizes to have a square lock core and contain an integral bonding strip of copper. 1-1/2-inch and larger to have fully interlocked core. Jacket material to be moisture, oil and sunlight resistant flexible PVC.

- B. Fittings: NEMA FB 2.20.

2.7 ELECTRICAL POLYVINYL CHLORIDE (PVC) CONDUIT

- A. Description: UL 651, NEMA TC 2; Schedule 40 PVC.
- B. Fittings: NEMA TC 3.

2.8 CONDUIT FITTINGS

- A. Bushings:
 - 1. Insulated type for threaded raceway connectors without factory-installed plastic throat conductor protection.
 - 2. Insulated grounding type for threaded raceway connectors.
- B. Raceway Connectors and Couplings:
 - 1. Steel connectors, couplings, and conduit bodies, hot-dip galvanized.
 - 2. Connector locknuts to be steel, with threads meeting ASTM tolerances. Locknuts to be hot-dip galvanized.
 - 3. Connector throats (EMT, flexible conduit, metal clad cable and cordset connectors) to have factory installed plastic inserts permanently installed. For normal cable or conductor exiting angles from raceway, the cable jacket or conductor insulation to bear only on plastic throat insert.
 - 4. Steel gland, Tomic or Breagle connectors and couplings are recognized for this Contract as having acceptable raceway to fitting electrical conductance.
 - 5. Set screw connectors and couplings, without integral compression glands, are recognized for this Contract as not having acceptable raceway to fitting electrical conductance. A ground conductor sized per this Specification must be included and bonded within raceway assembly utilizing this type connector or coupling.
- C. Provide expansion/deflection fittings for EMT.

PART 3 - EXECUTION

3.1 GENERAL INSTALLATION REQUIREMENTS

- A. Finished Surfaces: Schedule raceway installation to avoid conflict with installed wall and ceiling surfaces. If unavoidable, coordinate work and repairs with Architect.
- B. Conduit Size:
 - 1. Minimum Size: 3/4-inch for power and control, unless otherwise noted. 3/4-inch for communication/data, unless otherwise noted. 3/4-inch for signal systems, unless otherwise noted.
- C. Underground Installations:
 - 1. More than 5-feet from Foundation Wall: Use PVC.
 - 2. Within 5-feet from Foundation Wall: Use PVC coated RMC.
 - 3. In or Under Slab on Grade: Use PVC.
 - 4. Minimum Size: 1-inch.

- D. In Slab Above Grade:
 - 1. Use PVC.
 - 2. Maximum Size Conduit in Slab: Contact Structural Engineer for maximum outside diameter of conduit.
- E. Provide two pull strings/tapes in empty conduits. Types:
 - 1. Feeders: Polyester measure/pulling tape, Greenlee 4436 or approved.
 - 2. Branch Circuits and Low Voltage: Greenlee Poly Line 431 or approved.
 - 3. If fish tape is used for pulling line or low voltage wiring, fiberglass type to be used. Metal fish tapes will not be allowed.
 - 4. Secure pull string/tape at each end.
 - 5. Provide caps on ends of empty conduit to be used in future.
 - 6. Label both ends of empty conduits with location of opposite end.
- F. Elbows: Use fiberglass or PVC coated RMC for underground installations.
- G. Elbow for Low Energy Signal Systems: Use long radius factory ells where linking sections of raceway for installation of signal cable.
- H. Verify that field measurements are as shown on drawings.
- I. Plan locations of conduit runs in advance of the installation and coordinate with ductwork, plumbing, ceiling and wall construction in the same areas.
- J. Locate penetrations and holes in advance where they are proposed in the structural sections such as footings, beams, and walls. Penetrations are acceptable only when the following occurs:
 - 1. Where shown on the structural drawings.
 - 2. As approved by the Structural Engineer prior to construction, and after submittal of drawing showing location, size, and position of each penetration.
- K. Verify routing and termination locations of conduit prior to rough-in.
- L. Conduit routing is shown on drawings in approximate locations unless dimensioned. Route as required to complete wiring system.
- M. Install raceways securely, in neat and workmanlike manner, as specified in NECA 1, Standard Practices for Good Workmanship in Electrical Construction.
- N. Install steel conduit as specified in NECA 101, Standard for Installing Steel Conduits.
- O. Install nonmetallic conduit in accordance with manufacturer's instructions.
- P. Inserts, anchors and sleeves.
 - 1. Coordinate location of inserts and anchor bolts for electrical systems prior to concrete pour.
 - 2. Coordinate location of sleeves with consideration for other building systems prior to concrete pour.
- Q. Conduit Supports:

1. Arrange supports to prevent misalignment during wiring installation.
 2. Support conduit using coated steel or malleable iron straps, lay-in adjustable hangers, clevis hangers, and split hangers.
 3. Group related conduits; support using conduit rack. Construct rack using steel channel. Provide space on each for 25 percent additional conduits.
 4. Do not support conduit with wire or perforated pipe straps. Remove wire used for temporary supports.
 5. Do not attach conduit to ceiling support wires.
- R. Flexible steel conduit length not-to-exceed 6-feet, 3-feet in concealed walls. Provide sufficient slack to reduce the effect of vibration.
- S. Install conduit seals at boundaries where ambient temperatures differ by 10 degrees F or more as shown on the drawings. Install seals on warm side of partition.
- T. Seal raceways stubbing up into electrical equipment. Plug raceways with conductors with duct-seal. Cap spare raceways and plug PVC raceway products with plastic plugs as made by Underground Products, or equal, shaped to fit snugly into the stubup.
- U. Seal raceways penetrating an exterior building wall to prevent moisture and vermin from entering into the electrical equipment.
- V. Use suitable caps on spare and empty conduits to protect installed conduit against entrance of dirt and moisture.
- W. Keep 277/480 volt wiring independent of 120/208 volt wiring. Keep power wiring independent of communication system wiring.
- X. Keep emergency system wiring independent of other wiring systems per NEC 700.
- Y. Arrange conduit to maintain headroom and present neat appearance.
- Z. Do not install conduits on surface of building exterior, along vapor barrier, across roof, on top of parapet walls, or across floors, unless otherwise noted on drawings.
- AA. Exposed conduits are permitted only in following areas:
1. Mechanical rooms, electrical rooms or spaces where walls, ceilings and floors will not be covered with finished material.
 2. Existing walls that are concrete or block construction.
 3. Where specifically noted on Drawings.
 4. Route exposed conduit parallel and perpendicular to walls, tight to finished surfaces and neatly offset into boxes.
- AB. Do not install conduits or other electrical equipment in obvious passages, doorways, scuttles or crawl spaces which would impede or block area passage's intended usage.
- AC. Install continuous conduit and raceways for electrical power wiring and signal systems wiring.
- AD. Route conduit installed above accessible ceilings parallel and perpendicular to walls.
- AE. Maintain adequate clearance between conduit and piping.

- AF. Keep conduits a minimum of 12-inches away from steam or hot water radiant heating lines (at or above 104 degrees F) or 3-inches away from waste or water lines.
- AG. Cut conduit square using saw or pipecutter; deburr cut ends.
- AH. Bring conduit to shoulder of fittings; fasten securely.
- AI. Use conduit hubs to fasten conduit to cast boxes in damp and wet locations.
- AJ. Install no more than the equivalent of three 90 degree bends between boxes. Use conduit bodies to make sharp changes in direction, as around beams.
- AK. Use hydraulic one shot bender to fabricate elbows for bends in metal conduit larger than 2-inch size.
- AL. Avoid moisture traps; provide junction box with drain fitting at low points in conduit system.
- AM. Provide suitable fittings to accommodate expansion and deflection where conduit crosses seismic, control, and expansion joints.
- AN. Conduit Terminations for Signal Systems: Provide a plastic bushing on the end of conduit used for signal system wiring.
- AO. Feeders: Do not combine or change feeder runs.
- AP. Install conduit to preserve fire resistance rating of partitions and other elements, using materials and methods specified in Division 07, Thermal and Moisture Protection.
- AQ. Route conduit through roof openings for piping and ductwork wherever possible. Where separate roofing penetration is required, coordinate location and installation method with roofing installation and installer.

3.2 RIGID METAL CONDUIT (RMC) INSTALLATION

- A. Outdoor Locations Above Grade: RMC.
- B. Damp Locations: RMC.
- C. In areas exposed to mechanical damage: RMC.
- D. For security conduits installed exposed and subject to tampering: RMC.

3.3 POLYVINYL CHLORIDE (PVC) EXTERNALLY COATED GALVANIZED RIGID METAL CONDUIT INSTALLATION

- A. Use PVC coated RMC 36-inch radius ells for power service conduits and 48-inch radius ells for telephone service conduits.

3.4 ELECTRICAL METALLIC TUBING (EMT) INSTALLATION

- A. Dry Locations:
 - 1. Concealed: EMT.
 - 2. Exposed: EMT.
- B. Dry, Protected: EMT.

3.5 FLEXIBLE METAL CONDUIT (FMC) INSTALLATION

- A. Dry Locations: Motors, recessed luminaires and equipment connections subject to movement or vibration, use flexible metallic conduit.
- B. Install 12-inch minimum slack loop on flexible metallic conduit.

3.6 LIQUIDTIGHT FLEXIBLE METAL CONDUIT (LFMC) INSTALLATION

- A. Use PVC coated liquidtight flexible metallic conduit for motors and equipment connections subject to movement or vibration and subjected to any of following conditions: Exterior location, moist or humid atmosphere, corrosive environments, water spray, oil, or grease.
- B. Install 12-inch minimum slack loop on liquidtight flexible metallic conduit.

3.7 ELECTRICAL POLYVINYL CHLORIDE (PVC) CONDUIT INSTALLATION

- A. Install in accordance with manufacturer's instructions.
- B. Provide equipment grounding conductor in PVC conduit runs containing power conductors.
- C. Underground Installation:
 - 1. Areas subject to vehicular traffic: Schedule 80 PVC.
 - 2. Other underground applications: Schedule 40 PVC, except where prohibited by the NEC or local codes.
- D. Convert PVC conduit to Rigid Metal Conduit (RMC) prior to emerging from underground, concrete encasement, or concrete slab.
- E. Provide expansion fittings to compensate for expansion and contraction per NEC 352.44.
- F. PVC elbows are not acceptable. Use fiberglass or PVC coated RMC.
- G. Trim cut ends inside and outside to remove rough edges.
- H. Provide bushings when entering a box, fitting or other enclosure.

3.8 CONDUIT FITTINGS INSTALLATION

- A. Conduit Joints: Assemble conduits continuous and secure to boxes, panels, luminaires and equipment with fittings to maintain continuity. Provide watertight joints where embedded in concrete, below grade or in damp locations. Seal metal conduit with metal thread primer. Rigid

conduit connections to be threaded, clean and tight (metal to metal). Threadless connections are not permitted for RMC.

- B. Join nonmetallic conduit using cement as recommended by manufacturer. Wipe nonmetallic conduit dry and clean before joining. Apply full even coat of cement to entire area inserted in fitting. Allow joint to cure for 20 minutes, minimum.
- C. Use set screw type fittings only in dry locations. When set screw fittings are utilized provide insulated continuous equipment ground conductor in conduit, from overcurrent protection device to outlet.
- D. Use compression fittings in dry locations, damp and rain-exposed locations. Maximum size permitted in damp locations and locations exposed to rain is 2-inches in diameter.
- E. Use threaded type fittings in wet locations, hazardous locations, and damp or rain-exposed locations where conduit size is greater than 2-inches.
- F. Use PVC coated, threaded type fittings in corrosive environments.
- G. Use insulated type bushings with ground provision at switchboards, panelboards, safety disconnect switches, junction boxes that have feeders 60 amperes and greater.
- H. Condulets and Conduit Bodies:
 - 1. Do not use condulets and conduit bodies in conduits for signal wiring, in feeders 100 amp and larger, or for conductor splicing.
- I. Sleeves and Chases - Floor, Ceiling and Wall Penetrations: Provide necessary rigid conduit sleeves, openings and chases where conduits or cables are required to pass through floors, ceilings or walls.
- J. Expansion Joints:
 - 1. Provide conduits crossing expansion joints where cast in concrete with expansion-deflection fittings, installed per manufacturer's recommendations.
 - 2. Secure conduits 3-inches and larger to building structure on opposite sides of a building expansion joint with an expansion-deflection fitting across joint installed per manufacturer's recommendations.
 - 3. Provide conduits less than 3-inches where not cast in concrete with junction boxes securely fastened on both sides of expansion joint, connected together with 15-inches of slack (minimum of 15-inches longer than straight line length) flexible conduit and copper green ground bonding jumper. In lieu of this flexible conduit, an expansion-deflection fitting, as indicated for conduits 3-inch and larger may be installed.
 - 4. Verify expansion/deflection requirements with Structural Engineer prior to installation.
- K. Seismic Joints:
 - 1. No conduits cast in concrete allowed to cross seismic joint.
 - 2. Provide conduits with junction boxes securely fastened on both sides of seismic joint, connected together with 15-inches of slack (minimum of 15-inches longer than straight line length) flexible conduit and copper green ground bonding jumper. Prior to installation, verify with Architect that 15-inches is adequate for designed movement, and if not, increase this length as required.

3. Provide conduits less than 3-inches where not cast in concrete with junction boxes securely fastened on both sides of expansion joint, connected together with 15-inches of slack (minimum of 15-inches longer than straight line length) flexible conduit and copper green ground bonding jumper. In lieu of this flexible conduit, an expansion-deflection fitting, as indicated for conduits 3-inch and larger may be installed.

- L. Provide rigid conduit coupling flush with surface of slab or wall for conduit stubbed in concrete slab or wall to serve electrical equipment or an outlet under table or to supply shop tool, etc. Provide plug where conduit is to be used in future.

END OF SECTION

SECTION 26 0534 - BOXES

PART 1 - GENERAL

1.1 SUMMARY

A. Work Included:

1. Outlet Boxes
2. Outdoor Flush Grade Outlet Box
3. Pull and Junction Boxes
4. Box Extension Adapter
5. Weatherproof Outlet Boxes

- B. Provide electrical boxes and fittings for a complete installation. Include but not limited to outlet boxes, junction boxes, pull boxes, bushings, locknuts and other necessary components.

1.2 RELATED SECTIONS

- A. Contents of Division 26, Electrical and Division 01, General Requirements apply to this Section.

B. In addition, reference the following:

1. Section 26 05 33, Raceways
2. Section 26 05 53, Identification for Electrical Systems

1.3 REFERENCES AND STANDARDS

- A. References and Standards as required by Section 26 00 00, Electrical Basic Requirements and Division 01, General Requirements.

1.4 SUBMITTALS

- A. Submittals as required by Section 26 00 00, Electrical Basic Requirements and Division 01, General Requirements.

1.5 QUALITY ASSURANCE

- A. Quality assurance as required by Section 26 00 00, Electrical Basic Requirements and Division 01, General Requirements.

1.6 WARRANTY

- A. Warranty of materials and workmanship as required by Section 26 00 00, Electrical Basic Requirements and Division 01, General Requirements.

PART 2 - PRODUCTS

2.1 MANUFACTURERS

A. Outlet Boxes:

1. Hubbell

2. Thomas & Betts
 3. Eaton/Crouse-Hinds
 4. Or approved equivalent.
- B. Outdoor Flush Grade Outlet Box
1. Legrand (Wiremold)
 2. Or approved equivalent.
- C. Pull and Junction Boxes:
1. Eaton/Crouse-Hinds
 2. Hoffman
 3. Or approved equivalent.
- D. Box Extension Adapter:
1. Hubbell
 2. Thomas & Betts
 3. Eaton/Crouse-Hinds
 4. Or approved equivalent.
- E. Weatherproof Outlet Boxes:
1. Legrand (Pass & Seymour)
 2. Hubbell
 3. Thomas & Betts
 4. Eaton/Crouse-Hinds
 5. Intermatic
 6. Or approved equivalent.

2.2 OUTLET BOXES

- A. Luminaire Outlet: 4-inch octagonal box, 1-1/2-inches deep with 3/8-inch luminaire stud if required. Provide raised covers on bracket outlets and on ceiling outlets.
- B. Device Outlet: Installation of one or two devices at common location, minimum 4-inches square, minimum 1-1/2-inches deep for non-USB type devices. Installation of one or two devices at common locations, minimum 4-inches square, minimum 2-inches deep for USB type devices. Single- or two-gang flush device raised covers.
- C. Telecom Outlet: Provide 4-inches square, minimum 2-1/8-inch deep box with two-gang plaster ring.
- D. Multiple Devices: Three or more devices at common location. Install one-piece gang boxes with one-piece device cover. Install one device per gang.
- E. Masonry Boxes: Outlets in concrete.
- F. Construction: For interior locations, provide galvanized steel outlet wiring boxes, of the type, shape and size, including depth of box, to suit each respective location and installation; constructed with stamped knockouts in back and sides, and with threaded holes with screws for securing box covers or wiring devices. All surface mounted outlet boxes are to be drawn. Welded boxes are not acceptable.

- G. Accessories: Provide outlet box accessories for each installation, including mounting brackets, wallboard hangers, extension rings, luminaire studs, cable clamps and metal straps for supporting outlet boxes, compatible with outlet boxes being used and meeting requirements of individual wiring situations.
- H. Noise Control: Provide acoustic putty pad to back side of each outlet box installed in acoustic rated walls.

2.3 OUTDOOR FLUSH GRADE OUTLET BOX

- A. Gangable, Outdoor, Flush Mounted In Ground, Outlet Box Basis of Design: Legrand (Wiremold) XB814 series UV and chemical-resistant F1 rated nonmetallic housing with gray, black, or brown XB814C series cover assembly and built-in cable guides to organize cables. NEMA Type 6P and 4X, and IP 65 and 68 ratings. Uses air gap to prevent water intrusion; in-use design to allow installation in all weather conditions.
- B. Outlet Insert: 2-gang, 20 amp, duplex receptacles, single 30 amp locking L5-30R (125V) receptacle, single 30 amp locking L6-30R (250V) receptacle, or 2-gang low voltage box for communication and/or AV.
- C. Cover: UV-resistant; ANSI/SCTE 77 Tier 5 rating capable of withstanding 5000lb load.
- D. Cover Finish: Gray, Black, or Brown.

2.4 PULL AND JUNCTION BOXES

- A. Construction: Provide ANSI 49 gray enamel painted sheet steel junction and pull boxes, with screw-on covers; of type shape and size, to suit each respective location and installation; with welded seams and equipped with stainless steel nuts, bolts, screws and washers.
- B. Location:
 - 1. Provide junction boxes above accessible ceilings for drops into walls for receptacle outlets from overhead.
 - 2. Provide junction boxes and pull boxes to facilitate installation of conductors and limiting accumulated angular sum of bends between boxes, cabinets and appliances to 270 degrees.
- C. In-Ground Cast Metal Box: NEMA 250, Type 6, outside flanged, recessed cover box for flush mounting:
 - 1. Construction: Galvanized cast iron.
 - 2. Cover: Smooth cover with neoprene gasket and stainless steel cover screws.
 - 3. Cover Legend: ELECTRIC.
- D. Fiberglass Handholes: Die molded glass fiber hand holes:
 - 1. Cable Entrance: Pre-cut 6- x 6-inch cable entrance at center bottom of each side.
 - 2. Cover: Fiberglass weatherproof cover with nonskid finish.
 - 3. Cover Legend: ELECTRIC.

2.5 BOX EXTENSION ADAPTER

- A. Construction: Diecast aluminum.
- B. Location: Install over flush wall outlet boxes to permit flexible raceway extension from flush outlet to fixed or movable equipment.

2.6 WEATHERPROOF OUTLET BOXES

- A. Construction: Provide corrosion-resistant cast metal weatherproof outlet wiring boxes, of the type, shape and size, including depth of box, with threaded conduit ends, cast metal faceplate with spring-hinged waterproof cap suitably configured for each application, including faceplate, gasket, blank plugs and corrosion proof fasteners. Weatherproof boxes to be constructed to have smooth sides, gray finish.

PART 3 - EXECUTION

3.1 GENERAL INSTALLATION REQUIREMENTS

- A. Coordinate locations of floor boxes and wall mounted wiring device boxes with architectural and structural floor plans prior to rough-in.
- B. Install boxes securely, in a neat and workmanlike manner, as specified in NECA 1, Standard Practice of Good Workmanship in Electrical Construction.
- C. Secure boxes rigidly to substrate upon which they are being mounted, or solidly embed boxes in concrete or masonry.
- D. Install in locations as shown on Drawings, and as required for splices, taps, wire pulling, equipment connections, and as required by NEC. Locate boxes and conduit bodies so as to ensure accessibility of electrical wiring.
- E. Set wall mounted boxes at elevations to accommodate mounting heights shown on Architectural Elevations.
- F. Electrical boxes are shown on drawings in approximate locations unless dimensioned.
 - 1. Adjust box locations up to 10-feet if required to accommodate intended purpose.
- G. Install boxes to preserve fire resistance rating of partitions and other elements, using materials and methods specified in Division 07, Thermal and Moisture Protection.
- H. Locate flush mounting box in masonry wall to require cutting of masonry unit corner only. Coordinate masonry cutting to achieve neat opening.
- I. Install flush mounting box without damaging wall insulation or reducing its effectiveness.
- J. Support boxes independently of conduit, except cast box that is connected to two rigid metal conduits both supported within 12-inches of box.

- K. Adjust boxes to be parallel with building lines. Boxes not plumb to building lines are not acceptable.
- L. Install knockout closures in unused box openings.
- M. Clean interior of boxes to remove dust, debris, and other material.
- N. Clean exposed surfaces and restore finish.

3.2 OUTLET BOXES INSTALLATION

- A. Mount outlet boxes, unless otherwise required by ADA, or noted on drawings, following distances above finished floor:
 - 1. Control Switches:
 - a. 48-inches to the top of outlet box.
 - b. 4-inches above top of backsplash at countertops/workstations, not-to-exceed 44-inches above finished floor to the top of outlet box per ADA requirements.
 - 2. Receptacles: 15-inches to the bottom of outlet box.
 - 3. Telecom Outlets: 15-inches to the bottom of outlet box.
 - 4. Other Outlets: As indicated in other sections of specifications or as detailed on drawings.
- B. Inaccessible Ceiling Areas: Install outlet and junction boxes no more than 6-inches from ceiling access panel or from removable recessed luminaire.
- C. Flush Outlets in Insulated Spaces: Maintain integrity of insulation and vapor barrier.
- D. Coordinate electrical device locations and elevations (switches and receptacles) with architectural drawings to prevent mounting devices in mirrors, back splashes, and behind cabinets.
- E. Locate outlet boxes to allow luminaires positioned as shown on reflected ceiling plan.
- F. Align adjacent wall mounted outlet boxes for switches, thermostats, and similar devices. Adjacent boxes not aligned vertically to be adjusted at no additional cost to Owner.
- G. Use flush mounting outlet box in finished areas.
- H. Do not install flush mounting box back-to-back in walls; provide minimum 6-inches separation. Provide minimum 24-inches in acoustic rated walls.
- I. In acoustical walls, apply acoustic putty pad on outlet box prior to installation of acoustical blanket.
- J. Secure flush mounting box to interior wall and partition studs. Accurately position to allow for surface finish thickness.
- K. Use stamped steel bridges to fasten flush mounting outlet box between studs.
- L. Use adjustable steel channel fasteners for hung ceiling outlet box.

- M. Use gang box where more than one device is mounted together. Do not use sectional box.
- N. Use gang box with plaster ring for single device outlets.
- O. Adjust flush-mounting outlets to make front flush with finished wall material.

3.3 OUTDOOR FLUSH GRADE OUTLET BOX INSTALLATION

- A. Install per manufacturer's instructions and recommendations.
- B. Install in well drained areas only. Do not use in areas with seasonal standing water.
- C. Do not install in permafrost areas.
- D. Do not install in areas where grade is not within 1 percent of level.
- E. Connect outlet to upstream GFCI breaker when using a 120 volt, 20 amp outlet.

3.4 PULL AND JUNCTION BOXES INSTALLATION

- A. Install pull boxes and junction boxes above accessible ceilings and in unfinished areas only.
- B. Inaccessible Ceiling Areas: Install outlet and junction boxes no more than 6-inches from ceiling access panel or from removable recessed luminaire.
- C. Do not fasten boxes to ceiling support wires.
- D. Large Pull Boxes: Use hinged enclosure in interior dry locations, surface-mounted cast metal box in other locations.

3.5 BOX EXTENSION ADAPTER INSTALLATION

- A. Match material to box.
- B. Install gaskets at exterior and wet locations.

3.6 WEATHERPROOF OUTLET BOXES INSTALLATION

- A. Use cast outlet box in exterior locations exposed to weather and wet locations.
- B. Install gaskets.

END OF SECTION

SECTION 26 0553 - IDENTIFICATION FOR ELECTRICAL SYSTEMS

PART 1 - GENERAL

1.1 SUMMARY

- A. Work Included:
 - 1. Equipment Nameplates
 - 2. Device Labels
 - 3. Wire Markers

1.2 RELATED SECTIONS

- A. Contents of Division 26, Electrical and Division 01, General Requirements apply to this Section.

1.3 REFERENCES AND STANDARDS

- A. References and Standards as required by Section 26 00 00, Electrical Basic Requirements and Division 01, General Requirements.

1.4 SUBMITTALS

- A. Submittals not required for this Section.

1.5 QUALITY ASSURANCE

- A. Quality assurance as required by Section 26 00 00, Electrical Basic Requirements and Division 01, General Requirements.
- B. In addition, meet the following:
 - 1. Manufacturer's Qualifications: Firms regularly engaged in manufacture of identification devices of types and sizes required.
 - 2. Manufacturer's standard products of categories and types required for each application as referenced in other Division 26, Electrical Sections. Where more than a single type is specified for application, provide single selection for each product category.
 - 3. Codes and Standards: Comply with ANSI A13.1 for lettering size, length of color field, colors, and viewing angles of identification devices unless otherwise indicated.

1.6 WARRANTY

- A. Warranty of materials and workmanship as required by Section 26 00 00, Electrical Basic Requirements and Division 01, General Requirements.

PART 2 - PRODUCTS

2.1 MANUFACTURERS

- A. Equipment Nameplates:
 - 1. B & I Nameplates
 - 2. Intellicum

3. JBR Associates
 4. Or approved equivalent.
- B. Device Labels:
1. Kroy
 2. Brady
 3. Or approved equivalent.
- C. Wire Markers:
1. Brady
 2. Panduit
 3. Sumitomo
 4. Or approved equivalent.

2.2 EQUIPMENT NAMEPLATES

- A. Engraved phenolic plastic, laminate, minimum 1/8-inch thick in the size indicated, with beveled edge border matching letter color. Federal specification L-P-387. All upper case letters in engraver standard letter style of the size and wording indicated. Punched for mechanical fastening, except where adhesive mounting is necessary due to substrate. Embossed tape style labels are not acceptable.
- B. Color:
1. Normal (Utility): White letters on black background.
 2. Life Safety/Critical (Emergency Systems): Black letters on orange background.
 3. Equipment Branch (Legally Required Standby Systems): Black letters on yellow background.
- C. Letter Size:
1. Use 1/2-inch letters minimum for identifying major equipment and loads, including switchgear, switchboards, etc.
 2. Use 1/4-inch or 1/2-inch letters minimum for identifying panels, breakers, etc.
 3. Use 3/16-inch minimum for identifying source, voltage, current, phase, and wire configurations.
- D. Fasteners: Self-tapping stainless steel screws, except contact-type permanent adhesive where screws cannot or should not penetrate the substrate.
- E. The Architect, Engineer, Commissioning Agent and Owner reserve the right to make modifications to the nameplates as necessary.
- F. Locations:
1. Switchgear, switchboards, sub-distribution switchboards, distribution panels, and branch panels.
 2. Main breakers and distribution breakers in switchgear, switchboards, and distribution panels.
 3. Equipment including, but not limited to, motor controllers, disconnects, and VFDs.
 4. Low-voltage equipment enclosures including, but not limited to, fire alarm panels, access control panels, and lighting control panels.
 5. Distribution transformers.

2.3 DEVICE LABELS

- A. Extra strength, laminated adhesive tape, with 3/16-inch black letters on clear background. Use only for identification of individual wall switches and receptacles. Indicate device name, source panel, and source circuits. Panel and circuit designation written in permanent marker on the back of the plate and inside the back-box. Do not provide punch tape style labels.
- B. Label all junction boxes to show system identification, source circuit, or raceway origin. In finished areas, utilize device label. In unfinished areas or above ceilings, use of permanent ink marker is acceptable.

2.4 WIRE MARKERS

- A. Description: Vinyl-cloth self-adhesive type wire markers.
- B. Locations: Each conductor at panelboard gutters, pull boxes, outlet boxes, junction boxes, and each load connection.
- C. Power and Lighting Circuits: Branch circuit or feeder number as indicated on drawings and source panel.
- D. Control Circuits: control wire number indicated on schematic and interconnection diagrams on drawings or shop drawings.

PART 3 - EXECUTION

3.1 GENERAL INSTALLATION REQUIREMENTS

- A. Coordinate designations used on Drawings with equipment nameplates and device labels.
- B. Install nameplates and labels parallel to equipment lines.
- C. Identify empty conduit and boxes with intended use.
- D. Provide typewritten branch panel schedules with protective clear transparent covers accounting for every breaker installed. Use actual room designations assigned by name or number near completion of the work, and not the designations shown on drawings.
- E. Provide color coded boxes as follows:
 - 1. Fire Alarm: Red.

3.2 EQUIPMENT NAMEPLATES

- A. Degrease and clean surfaces to receive nameplates.
- B. Secure equipment nameplates to equipment front using self-tapping stainless steel screws.
- C. Secure equipment nameplates to inside surface of door on panelboard that is recessed in finished locations.

- D. Verify emergency system distribution equipment nameplate colors with Architect/Owner.
- E. Switchgear, switchboards, and panels to include name source, voltage, current phase, wire configuration and fault current rating. Transformers to include source KVA, and secondary voltage, phase, and wire configuration.
- F. Provide nameplates for flush mounted branch panelboards identifying name on front door. On inside of door provide nameplate as noted above. Verify with Architect/Owner if nameplate on outside of door is required.
- G. Provide a second label at branch panelboards listing the means of identification of branch circuit conductors. This identification legend to consist of the color code used for each voltage system (208Y/120V and 480Y/277V). Include identification of both voltage systems on each label, regardless of the voltage of the panelboard to which the label is affixed. Comply with requirements of NEC 210.5.
 - 1. See Specification Section 26 05 19, Low-Voltage Electrical Power Conductors and Cables, for required conductor color code for this project.

3.3 DEVICE LABELS

- A. Reference 3.01, General Installation Requirements.
- B. Install per manufacturer's instructions and recommendations.
- C. Degrease and clean surfaces to receive labels.

3.4 WIRE MARKERS

- A. Reference 3.01, General Installation Requirements.
- B. Install per manufacturer's instructions and recommendations.
- C. Provide wire markers on each conductor for power, control, signalling and communications circuits.
- D. Where switches control remote lighting or power outlets, or where switches or outlets in same location serve different purposes, such as light, power, intercom, etc. or different areas, such as corridor and outside, provide plates with 1/8-inch black letters indicating function of each switch or outlet. Also label the function of light switches where two or more are mounted in same locations.

END OF SECTION

SECTION 26 0573 - ELECTRICAL DISTRIBUTION SYSTEM STUDIES

PART 1 - GENERAL

1.1 SUMMARY

- A. Work Included:
 - 1. Protective Devices
 - 2. Short Circuit Study
 - 3. Protective Device Study
 - 4. Selective Coordination Study
 - 5. Arc Flash Labels
 - 6. Arc Flash Risk Assessment

1.2 RELATED SECTIONS

- A. Contents of Division 26, Electrical and Division 01, General Requirements apply to this Section.

1.3 REFERENCES AND STANDARDS

- A. References and Standards as required by Section 26 00 00, Electrical Basic Requirements and Division 01, General Requirements.
- B. In addition, meet the following:
 - 1. IEEE 242, Recommended Practice for Protection and Coordination of Industrial and Commercial Power Systems.
 - 2. IEEE 399, Recommended Practice for Industrial and Commercial Power Systems Analysis.
 - 3. IEEE 1584, Guide for Performing Arc Flash Calculation.

1.4 SUBMITTALS

- A. Submittals as required by Section 26 00 00, Electrical Basic Requirements and Division 01, General Requirements.
- B. In addition provide:
 - 1. Power system studies required under this Section with submittals for electrical equipment, including overcurrent protective devices.
 - 2. Electrical equipment ordered prior to submittal of power system studies are not compliant with these specifications, and are subject to removal and replacement at no cost to Owner where not in compliance with Code and Contract Documents for selective coordination.
 - a. Provide written verification with Stamp or Seal and signature of preparing Engineer.
 - 3. Provide samples of NFPA 70E compliant arc flash hazard labeling for electrical equipment.

1.5 QUALITY ASSURANCE

- A. Quality assurance as required by Section 26 00 00, Electrical Basic Requirements and Division 01, General Requirements.
- B. In addition, meet the following:
 - 1. Study Preparer Qualifications: Qualified engineer of switchgear manufacturer or approved professional engineer.
 - a. Experienced in preparation of studies of similar type and magnitude.
 - b. Familiar with software analysis products specified.
 - 2. Computer Software for Study Preparation: Use latest edition of commercially available software utilizing specified methodologies.
 - a. Acceptable Software Products:
 - 1) EasyPower
 - 2) Operation Technology, Inc; ETAP.
 - 3) SKM Systems Analysis, Inc; Power Tools for Windows.
 - 3. Contractor Responsibility: Provide project-related data needed by study preparer, including equipment, wire sizes, insulation types, conduit types, actual circuit lengths and available fault currents from utility. Provide information in a timely matter to allow studies to be completed prior to release of equipment.

1.6 WARRANTY

- A. Warranty of materials and workmanship as required by 26 00 00, Electrical Basic Requirements and Division 01, General Requirements.

PART 2 - PRODUCTS

2.1 GENERAL

- A. Analyze specific electrical and utilization equipment (according to NEC definition), actual protective devices to be used, and actual feeder lengths to be installed.
 - 1. Scope of Studies: New and existing distribution wiring and equipment, from primary source to buses and branch circuit panelboards.
 - 2. Primary Source, for Purposes of Studies: Utility company primary protective devices.
 - 3. Study Methodology: Comply with requirements and recommendations of NFPA 70, IEEE 399, and IEEE 242.
 - 4. Report: State methodology and rationale employed in making each type of calculation; identify computer software package(s) used.
- B. One-Line Diagrams: Prepare schematic drawing of electrical distribution system, with electrical equipment and wiring to be protected by protective devices; identify nodes on diagrams for reference on report that includes:
 - 1. Calculated fault impedance, X/R ratios, utility contribution, and short circuit values (asymmetric and symmetric) at main switchboard bus and downstream devices containing protective devices.
 - 2. Breaker and fuse ratings.
 - 3. Generator kW and voltage ratings, percent impedance, X/R ratios, and wiring connections.

4. Transformer kVA and voltage ratings, percent impedance, X/R ratios, and wiring connections.
5. Identification of each bus, with voltage.
6. Conduit materials, feeder sizes, actual lengths, and X/R ratios.

2.2 PROTECTIVE DEVICES

- A. Provide protective devices of ratings and settings as required so that protective device closest to fault will open first.
- B. Replace existing protective devices to achieve specified performance.
- C. Analyze and determine ratings and settings of protective devices to minimize damage caused by fault and so that protective device closest to fault will open first.
 1. Required Ratings and Settings: Derive required ratings and settings of protective devices in consideration of upstream protective device settings and optimize system to ensure selective coordination.
 2. Motors with Solid-State Protective Modules: Select settings for best possible motor protection, taking into consideration actual installed motor torque and current and thermal characteristics.
 3. Identify any equipment that is underrated as specified.
 4. Identify specified protective devices that will not achieve required protection or coordination but with minor changes can be made to do so; provide such modified devices at no additional cost to Owner and identify them on submittals as "revised in accordance with Protective Device Coordination Study"; minor changes include different trip sizes in same frame, time curve characteristics of induction relays, CT ranges, etc.
 5. Identify specified protective devices that will not achieve required protection or coordination and cannot be field adjusted to do so, and for which adequate devices would involve change to contract sum.
 6. In all cases where adequate protection or coordination cannot be achieved at no extra cost to Owner, provide a discussion of alternatives and logical compromises for best achievable coordination.
 7. Do not order, furnish, or install protective devices that do not meet performance requirements unless specifically approved by Engineer.
- D. Protective Device Rating and Setting Chart: Summarize in tabular format required characteristics for each protective device based on analysis; include:
 1. Device identification.
 2. Relay CT ratios, tap, time dial, and instantaneous pickup.
 3. Circuit breaker sensor rating, long-time, short-time, and instantaneous settings, and time bands.
 4. Fuse rating and type.
 5. Ground fault pickup and time delay.
 6. Input level and expected response time at two test points that are compatible with commonly available test equipment and ratings of protective device.
 7. Highlight devices that as furnished by Contractor will not achieve required protection.
- E. Specified equipment has been designed and selected to achieve specified performance; ensure that equipment actually installed provides that performance.

- F. In addition to requirements specified elsewhere, provide overcurrent protective devices having ratings and settings in accordance with results of system studies.

2.3 SHORT CIRCUIT STUDY

- A. Calculate fault impedance to determine available 3-phase short circuit and ground fault currents at each bus and piece of equipment during normal conditions, alternate operations, emergency power conditions, and other operations that could result in maximum fault conditions.
 - 1. Show fault currents available at key points in system down to fault current of 1,000 A at 480 V and 208 V.
 - 2. Include motor contributions in determining momentary and interrupting ratings of protective devices.
 - 3. Primary Fault Level Assumptions: Obtain data from utility company.

2.4 PROTECTIVE DEVICE STUDY

- A. Analyze and determine ratings and settings of protective devices to minimize damage caused by fault and so that protective device closest to fault will open first.
 - 1. Required Ratings and Settings: Derive required ratings and settings of protective devices in consideration of upstream protective device settings and optimize system to ensure selective coordination.
 - 2. Motors with Solid-State Protective Modules: Select settings for best possible motor protection, taking into consideration actual installed motor torque and current and thermal characteristics.
 - 3. Identify any equipment that is underrated as specified.
 - 4. Identify existing protective devices that will not achieve required coordination and cannot be field adjusted to do so.
 - 5. Identify specified protective devices that will not achieve required protection or coordination but with minor changes can be made to do so; provide such modified devices at no additional cost to Owner and identify them on submittals as "revised in accordance with Protective Device Coordination Study"; minor changes include different trip sizes in same frame, time curve characteristics of induction relays, CT ranges, etc.
 - 6. Identify specified protective devices that will not achieve required protection or coordination and cannot be field adjusted to do so, and for which adequate devices would involve change to contract sum.
 - 7. In all cases where adequate protection or coordination cannot be achieved at no extra cost to Owner, provide a discussion of alternatives and logical compromises for best achievable coordination.
 - 8. Do not order, furnish, or install protective devices that do not meet performance requirements unless specifically approved by Architect.
- B. Protective Device Rating and Setting Chart: Summarize in tabular format required characteristics for each protective device based on analysis; include:
 - 1. Device identification.
 - 2. Relay CT ratios, tap, time dial, and instantaneous pickup.
 - 3. Circuit breaker sensor rating, long-time, short-time, and instantaneous settings, and time bands.
 - 4. Fuse rating and type.
 - 5. Ground fault pickup and time delay.

6. Input level and expected response time at two test points that are compatible with commonly available test equipment and ratings of protective device.
7. Highlight devices that as furnished by Contractor will not achieve required protection.

2.5 SELECTIVE COORDINATION STUDY

- A. For all emergency, legally required standby and critical operations systems over current devices, perform an organized time-current analysis of each protective device in series from individual device back to source, under normal and emergency power conditions.
 1. Graphically illustrate that adequate time separation exists between series devices, including upstream primary device.
 2. Plot specific time-current characteristics of each protective device on log-log paper.
 3. Organize plots so that upstream devices are clearly depicted on one sheet.
 4. Also show following on curve plot sheets:
 - a. Device identification.
 - b. Voltage and current transformer ratios for curves.
 - c. 3-phase and 1-phase ANSI damage curves for each transformer.
 - d. No-damage, melting, and clearing curves for fuses.
 - e. Cable damage curves.
 - f. Transformer inrush points.
 - g. Maximum short circuit cutoff point.
 - h. Simple one-line diagram for portion of system that each curve plot illustrates.
 - i. Software report for each curve plot, labeled for identification.
- B. Devices to coordinate down to 0.01 seconds. Coordination required for emergency systems, legally required systems, and elevators.

2.6 ARC FLASH LABELS

- A. Provide label compliant with NFPA 70E guidelines indicating personal protective equipment (PPE) recommended for servicing of electrical equipment while energized, as well as calculated incident energy levels and arc flash protective boundary distance.

2.7 ARC FLASH RISK ASSESSMENT

- A. Calculate arc flash incident energy (AFIE) levels and flash protection boundary distances to determine required level of personal protective equipment (PPE) at each bus and piece of equipment during normal conditions, emergency power conditions, and other operations that could result in maximum arc flash incident energy levels.
 1. Show flash protection boundary distance.
 2. Include incident energy levels.

PART 3 - EXECUTION

3.1 FIELD QUALITY CONTROL

- A. Provide services of qualified field engineer and necessary tools and equipment to test, calibrate, and adjust installed protective devices to conform to requirements determined by coordination analysis.

- B. Adjust installed protective devices having adjustable settings to conform to requirements determined by coordination analysis.
- C. Submit report showing final adjusted settings of protective devices.

3.2 ELECTRICAL POWER SYSTEM STUDIES

A. Short Circuit Analysis Study:

1. Provide complete short circuit study, equipment interrupting and withstand evaluation. Study to include complete electrical distribution system, including contributions from normal source of power without alternative sources of power. Include complete low voltage distribution systems as specified in this Section.
2. Study Basis: thoroughly cover normal and alternative operation modes that can produce maximum fault conditions, including simultaneous motor contributions.
3. Perform study in accordance with applicable ANSI/IEEE Standards.
4. Study Input Data: Utility company short circuit single and three phase contribution, and X/R ratio; resistance and reactance components of each feeder, busway and branch impedance; motor and generator contributions; applicable circuit parameters and contribute to short circuit duty.
5. Calculate short circuit momentary duties and interrupting duties on basis of maximum available fault current at each switchgear bus, switchboard, motor control center, panelboards, transfer switches, busway plug connection point, dry-type transformer primary and secondary locations, other significant locations throughout system affected by available fault current (including large HVAC units, uninterruptible power supplies, etc.).
6. Perform equipment evaluation study to determine adequacy of overcurrent protection devices by tabulating and comparing short circuit ratings of these devices with available fault current. Notify Owner in writing where problem areas or inadequacies appear in electrical equipment.
7. Study Report: In bound final report, include sheets listing tabulated information from study, including feeder impedances, motor, utility and generator impedances and fault contributions, and resulting short circuit current including asymmetrical, symmetrical, three, five and eight cycle fault current levels, and line-to-neutral and three-phase-bolted-fault current levels at each calculated point in electrical distribution system.

B. Protective Device Study:

1. Perform time-current coordination analysis with aid of computer software intended for this purpose. Include determination of settings, ratings, or types for overcurrent protective devices supplied.
2. Where necessary, make an appropriate compromise between system protection and service continuity with service continuity considered more important than system protection.
3. Provide sufficient number of computer generated log-log plots to indicate degree of system protection and coordination by displaying time-current characteristics of series connected overcurrent devices and other pertinent system parameters.
4. Computer printouts accompany log-log plots and will contain descriptions for each of devices shown, settings of adjustable devices, short-circuit current availability at device

- location when known, and device identification numbers to aid in locating devices on log-log plots and system one-line diagram.
5. Study includes separate, tabular computer printout containing suggested device settings of adjustable overcurrent protective devices, equipment where device is located, and device number corresponding to device on system one-line diagram.
 6. Provide computer generated system one-line diagram which clearly identifies individual equipment buses, bus numbers, device identification numbers and maximum available short-circuit current at each bus when known.
 7. Discussion Section which evaluates degree of system protection and service continuity with overcurrent devices, along with recommendations as required for addressing system protection or device coordination deficiencies.
 8. Call significant deficiencies in protection and/or coordination to attention of Engineer and recommendations made for improvements as soon as they are identified.
 9. Contractor responsible for supplying pertinent electrical system conductor, circuit breaker, generator, and other component and system information in timely manner to allow time-current analysis to be completed prior to final installation.
- C. Selective Coordination Study:
1. Perform time-current coordination analysis with aid of computer software intended for this purpose. Include determination of settings, ratings, or types for overcurrent protective devices supplied.
 2. Where necessary, make an appropriate compromise between system protection and service continuity with service continuity considered more important than system protection.
 3. Provide sufficient number of computer generated log-log plots to indicate degree of system protection and coordination by displaying time-current characteristics of series connected overcurrent devices and other pertinent system parameters.
 4. Time-Current Coordination Curves: Determine settings of overcurrent protective devices to achieve selective coordination. Graphically illustrate that adequate time separation exists between devices installed in series, including power utility company's upstream devices. Prepare separate sets of curves for the switching schemes and for emergency periods where the power source is local generation. Show the following information:
 - a. Device tag and title, one-line diagram with legend identifying the portion of the system covered.
 - b. Terminate device characteristic curves at a point reflecting maximum symmetrical fault current to which the device is exposed.
 - c. Identify the device associated with each curve by manufacturer type, function, and, if applicable, tap, time delay, and instantaneous settings recommended.
 - d. No more than 3 devices per TCC.
 - e. Plot the following listed characteristic curves, as applicable:
 - 1) Power utility's overcurrent protective device.
 - 2) Medium-voltage equipment overcurrent relays.
 - 3) Medium- and low-voltage fuses including manufacturer's minimum melt, total clearing, tolerance, and damage bands.
 - 4) Low-voltage equipment circuit-breaker trip devices, including manufacturer's tolerance bands.
 - 5) Transformer full-load current, magnetizing inrush current, and ANSI through-fault protection curves.
 - 6) Cables and conductors damage curves.
 - 7) Ground-fault protective devices.

- 8) Generator short-circuit decrement curve and generator damage point.
 - 9) The largest feeder circuit breaker in each motor-control center and panelboard.
5. Study includes separate, tabular computer printout containing suggested device settings of adjustable overcurrent protective devices, equipment where device is located, and device number corresponding to device on system one-line diagram.
 6. Provide computer generated system one-line diagram which clearly identifies individual equipment buses, bus numbers, device identification numbers and maximum available short-circuit current at each bus when known.
 7. Discussion Section which evaluates degree of system protection and service continuity with overcurrent devices, along with recommendations as required for addressing system protection or device coordination deficiencies.
 8. Call significant deficiencies in protection and/or coordination to attention of Engineer and recommendations made for improvements as soon as they are identified.
 9. Contractor responsible for supplying pertinent electrical system conductor, circuit breaker, generator, and other component and system information in timely manner to allow time-current analysis to be completed prior to final installation.
- D. Arc Flash Risk Assessment:
1. Perform arc flash risk assessment with aid of computer software intended for this purpose.
 2. Perform arc flash risk assessment in conjunction with short-circuit analysis and time-current coordination analysis.
 3. Submit results of assessment in tabular form, and include device or bus name, bolted fault and arcing fault current levels, flash protection boundary distances, personal-protective equipment classes and AFIE levels.
 4. Perform analysis under worst-case arc flash conditions, and final report describes, when applicable, how these conditions differ from worst-case bolted fault conditions.
 5. Arc flash risk assessment includes recommendations for reducing AFIE levels and enhancing worker safety.
 6. Proposed vendor demonstrates experience with arc flash risk assessment by submitting names of at least ten actual arc flash risk assessments it has performed in past year.
 7. Proposed vendor demonstrates capabilities in providing equipment, services, and training to reduce arc flash exposure and train workers in accordance with NFPA 70E and other applicable standards.
 8. Proposed vendor demonstrates experience in providing equipment labels in compliance with NEC and ANSI Z535.4 to identify AFIE and appropriate Personal Protective Equipment classes.
- E. Load-Flow And Voltage Drop Study:
1. Perform a load-flow and voltage drop study to determine the steady state loading profile of the system. Determine load-flow and voltage drop based of full load current shown in the design. The model should include all loads indicated in the panel schedules, one-line diagram, and equipment connection schedules, as applicable.
 2. Prepare the load-flow and voltage-drop analysis and report to show power system components that are overloaded; indicate voltage drop for all buses in the system.
 3. Provide recommendations for areas that have voltage drop values higher than 2-percent for feeders.

4. Indicate the recommended fixed transformer taps that might be used to solve the voltage drop issues.

END OF SECTION

SECTION 26 0800 - COMMISSIONING OF ELECTRICAL

PART 1 - GENERAL

1.1 SUMMARY

- A. Section includes: Definitions, warranties, test equipment requirements, and electrical commissioning requirements as required by the Owner's Project Requirements.

1.2 RELATED SECTIONS

- A. Contents of Division 26, Electrical and Division 01, General Requirements apply to this section.
- B. Reference Section 01 91 13, General Commissioning Requirements.

1.3 WARRANTY

- A. Manufacturer's Warranty:
 - 1. Commissioning, inspecting, and testing not to modify terms or time periods of electrical equipment, systems, and controls warranties including related equipment and systems, and adjacent work.
 - 2. Electrical system warranties to start from date of Commissioning Agent acceptance.

1.4 REFERENCES AND STANDARDS

- A. References and Standards as required by Section 26 00 00, Electrical Basic Requirements and Division 01, General Requirements.
- B. In addition, reference:
 - 1. ASHRAE Guideline 0, The Commissioning Process.
 - 2. NECA 90, Commissioning Building Electrical Systems.

1.5 SUBMITTALS

- A. Reference Section 01 91 13, General Commissioning Requirements, for specific submittal requirements.
- B. In addition, submit the following:
 - 1. Certificates of readiness.
 - 2. Certificates of completion of installation, prestart, and startup activities.
 - 3. Operations and Maintenance (O&M) manuals.
 - 4. Test reports.

1.6 COORDINATION

- A. Reference Section 01 91 13, General Commissioning Requirements, for requirements pertaining to coordination during the commissioning process.

1.7 DEFINITIONS

- A. Commissioning Authority: Commissioning Agent, representing the Owner and directing commissioning activities.

PART 2 - PRODUCTS

2.1 TEST EQUIPMENT

- A. Provide testing equipment required to perform startup, initial checkout and functional performance testing for the equipment being tested under Division 26, Electrical. Furnish two-way radios for each testing participant.
- B. Furnish special equipment, tools and instruments (specific to tested equipment and only available from vendor) required for testing. At conclusion of commissioning, turn equipment over to the Owner except for stand-alone data logging equipment that may be used by the Commissioning Authority.
- C. Manufacturer: Furnish proprietary test equipment and software required by equipment manufacturer procedures for programming and/or start-up. Demonstrate its use, and assist in the commissioning process as needed. Proprietary test equipment (and software) to become the property of the Owner upon completion of the commissioning process.
- D. Data logging equipment and software required to test equipment will be furnished by the Commissioning Authority during commissioning.
- E. Testing equipment to be of sufficient quality and accuracy to test and/or measure system performance with the tolerances specified in the Specifications.

PART 3 - EXECUTION

3.1 GENERAL DOCUMENTATION REQUIREMENTS

- A. With assistance from the installing contractors, the Commissioning Authority will prepare Pre-Functional Checklists for commissioned components, equipment, and systems.
- B. Red-lined Drawings:
 - 1. Verify equipment, systems, instrumentation, wiring and components are shown correctly on red-lined drawings.
 - 2. Record the red-lined drawing changes, as a result of Functional Testing and incorporate into the final as-built drawings.
- C. Operation and Maintenance Data:
 - 1. Submit a copy of O&M literature within 45 days of each submittal acceptance for use during the commissioning process for commissioned equipment and systems.
 - 2. The Commissioning Authority will review the O&M literature once for conformance to project requirements.
 - 3. The Commissioning Authority will receive a copy of the final approved O&M literature once corrections have been made by the Contractor.

- D. Demonstration and Training:
1. Provide demonstration and training as required by the specifications.
 2. Submit complete training plan and schedule to the Commissioning Authority four weeks prior to training.
 3. Submit training agenda for each training session to the Commissioning Authority one week prior the training session.
 4. Notify the Commissioning Authority at least 72 hours in advance of scheduled tests so that testing may be observed by the Commissioning Authority and Owner's Authorized Representative. Submit copies of the test record to the Commissioning Authority, Owner, and Architect.
 5. Engage a Factory-authorized service representative to train Owner's maintenance personnel to adjust, operate, and maintain specific equipment.
 6. Train Owner's maintenance personnel on procedures and schedules for starting and stopping, trouble shooting, servicing, and maintaining equipment.
 7. Review data in O&M Manuals.

3.2 CONTRACTOR'S RESPONSIBILITIES

- A. Perform commissioning tests at the direction of the Commissioning Authority.
- B. Attend construction phase controls coordination meetings.
- C. Participate in Electrical systems, assemblies, equipment, and component maintenance orientation and inspection as directed by the Commissioning Authority.
- D. Provide information requested by the Commissioning Authority for final commissioning documentation.
- E. Include requirements for submittal data, operation and maintenance data, and training in each purchase order or sub-contract written.
- F. Prepare preliminary schedule for Electrical system orientation and inspections, operation and maintenance manual submissions, training sessions, equipment start-up and task completion for owner. Distribute preliminary schedule to commissioning team members.
- G. Update schedule as required throughout the construction period.
- H. During the startup and initial checkout process, execute the related portions of the prefunctional checklists for commissioned equipment.
- I. Contractor to participate and complete checklists using the Commissioning Authority's web based commissioning software Facility Grid. A desktop, laptop, tablet, or iPad will be required.
- J. Assist the Commissioning Authority in verification and functional performance tests.
- K. Provide measuring instruments and logging devices to record test data, and provide data acquisition equipment to record data for the complete range of testing for the required test period.

- L. Gather operation and maintenance literature on equipment, and assemble in binders as required by the specifications. Submit to Commissioning Authority 45 days after submittal acceptance.
- M. Coordinate with the Commissioning Authority to provide 48-hour advance notice so that the witnessing of equipment and system start-up and testing can begin.
- N. Participate in, and schedule vendors and contractors to participate in the training sessions.
- O. Provide written notification to the CM/GC and Commissioning Authority that the following work has been completed in accordance with the Contract Documents, and that the equipment, systems, and sub-system are operating as required.
 - 1. Electrical equipment including switchgear, panel boards, motor control centers, lighting, receptacles, dimmers and other equipment furnished under this Division.
 - 2. Automatic Lighting Controls.
 - 3. Emergency generators, ATS switches and emergency power systems.
 - 4. Fire Alarm System.
 - 5. UPS Systems.
 - 6. Photovoltaic Energy Systems.
- P. Obtain performance documentation from equipment supplier.
- Q. Provide training of the Owner's operating staff using expert qualified personnel.
- R. Equipment Suppliers
 - 1. Submit requested submittal data, including detailed start-up procedures and specific responsibilities of the Owner, to keep warranties in force.
 - 2. Assist in equipment testing per agreements with contractors.
 - 3. Provide information requested by Commissioning Authority regarding equipment sequence of operation and testing procedures.

3.3 TESTING PREPARATION

- A. Certify in writing to the Commissioning Authority that Electrical systems, subsystems, and equipment have been installed and started and are operating according to the Contract Documents.
- B. Certify in writing to the Commissioning Authority that Electrical instrumentation and control systems have been completed and that they are operating according to the Contract Documents.
- C. Certify in writing that testing procedures have been completed and that testing reports have been submitted, discrepancies corrected, and corrective work approved.
- D. Place systems, subsystems, and equipment into operating mode to be tested (e.g., normal shutdown, normal auto position, normal manual position, emergency power, and alarm conditions).
- E. Inspect and verify the position of each device and interlock identified on checklists.
- F. Testing Instrumentation: Install measuring instruments and logging devices to record test data as directed by the Commissioning Authority.

3.4 GENERAL TESTING REQUIREMENTS

- A. Provide technicians, instrumentation, and tools to perform commissioning test at the direction of the Commissioning Authority.
- B. Scope of Electrical testing includes the entire Electrical installation, from the incoming power equipment throughout the distribution system. Testing includes measuring, but is not limited to resistance, voltage, and amperage of system(s) and devices.
- C. Test operating modes, interlocks, control responses, and responses to abnormal or emergency conditions, and verify proper response of building automation system controllers and sensors.
- D. The Commissioning Authority along with the Electrical contractor and other contracted subcontractors, including the fire alarm Subcontractor to prepare detailed testing plans, procedures, and checklists for Electrical systems, subsystems, and equipment.
- E. Tests will be performed using design conditions whenever possible.
- F. Simulated conditions may need to be imposed using an artificial load when it is not practical to test under design conditions. Before simulating conditions, calibrate testing instruments. Provide equipment to simulate loads. Set simulated conditions as directed by the Commissioning Authority and document simulated conditions and methods of simulation. After tests, return settings to normal operating conditions.
- G. The Commissioning Authority may direct that set points be altered when simulating conditions is not practical.
- H. The Commissioning Authority may direct that sensor values be altered with a signal generator when design or simulating conditions and altering set points are not practical.
- I. If tests cannot be completed because of a deficiency outside the scope of the Electrical system, document the deficiency and report it to the Owner. After deficiencies are resolved, reschedule tests.
- J. If the testing plan indicates specific seasonal testing, complete appropriate initial performance tests and documentation and schedule seasonal tests.

3.5 ELECTRICAL SYSTEMS, SUBSYSTEMS, AND EQUIPMENT TESTING PROCEDURES

- A. Equipment Testing and Acceptance Procedures: Testing requirements are specified in individual Division 26, Electrical Sections. Provide submittals, test data, inspector record and certifications to the Commissioning Authority.
- B. Electrical Instrumentation and Control System Testing: Field testing plans and testing requirements are specified in Division 26, Electrical Controls Sections. Assist the Commissioning Authority with preparation of testing plans.
- C. Emergency Generator Testing and Acceptance Procedures: Provide technicians, load banks, infrared cameras, instrumentation, tools and equipment to test performance of designated systems and devices at the direction of the Commissioning Authority.

- D. Electrical Distribution System Testing: Provide technicians, load banks, infrared cameras, instrumentation, tools and equipment to test performance of designated systems and devices at the direction of the Commissioning Authority.
- E. The work included in the commissioning process involves a complete and thorough evaluation of the operation and performance of components, systems and sub-systems. Evaluate the following equipment and systems:
 - 1. Automatic Lighting Controls (LCP, Occupancy Sensors, Daylighting Controls)

3.6 PHOTOVOLTAIC ENERGY SYSTEM TESTING AND ACCEPTANCE PROCEDURES

- A. Provide technicians, tools, instrumentation and equipment to test performance of panels, inverters, combined panels and monitoring equipment of designated solar PV systems and components at the direction of the Commissioning Authority.

3.7 DEFICIENCIES/NON-CONFORMANCE, COST OF RETESTING, FAILURE DUE TO MANUFACTURER DEFECT

- A. Reference Section 01 91 13, General Commissioning Requirements, for requirements pertaining to deficiencies/non-conformance, cost of retesting, or failure due to manufacturer defect.

3.8 OPERATION AND MAINTENANCE (O&M) MANUALS

- A. The Operation and Maintenance Manuals to conform to Contract Documents requirements as stated in Division 26, Electrical.

3.9 TRAINING OF OWNER PERSONNEL

- A. Electrical Contractor's training responsibilities:
 - 1. Provide the Commissioning Authority with a training plan two weeks before the planned training.
 - 2. Provide designated Owner personnel with comprehensive training in the understanding of the systems and the operation and maintenance of each major piece of commissioned electrical equipment or system.
 - 3. Training starts with classroom sessions, if necessary, followed by hands on training on each piece of equipment, which illustrates the various modes of operation, including startup, shutdown, fire/smoke alarm, power failure, etc.
 - 4. During any demonstration, should the system fail to perform in accordance with the requirements of the O&M manual or sequence of operations, the system will be repaired or adjusted as necessary and the demonstration repeated.
 - 5. The appropriate trade or manufacturer's representative provides the instructions on each major piece of equipment. This person may be the start-up technician for the piece of equipment, the installing contractor or manufacturer's representative. Practical building operating expertise as well as in-depth knowledge of modes of operation of the specific piece of equipment are required. More than one party may be required to execute the training.
 - 6. The training sessions follows the outline in the Table of Contents of the operation and maintenance manual and illustrate whenever possible the use of the O&M manuals for reference.
 - 7. Training includes:

- a. Use the printed installation, operation and maintenance instruction material included in the O&M manuals.
- b. Include a review of the written O&M instructions emphasizing safe and proper operating requirements, preventative maintenance, special tools needed and spare parts inventory suggestions. The training includes start-up, operation in modes possible, shut-down, seasonal changeover and any emergency procedures.
- c. Discuss relevant health and safety issues and concerns.
- d. Discuss warranties and guarantees.
- e. Cover common troubleshooting problems and solutions.
- f. Explain information included in the O&M manuals and the location of plans and manuals in the facility.
- g. Discuss any peculiarities of equipment installation or operation.
8. Hands-on training includes start-up, operation in modes possible, including manual, shut-down and any emergency procedures and preventative maintenance of pieces of equipment.
9. Fully explain and demonstrate the operation, function and overrides of any local packaged controls, not controlled by the central control system.
10. Schedule training after functional testing is complete, unless approved otherwise by the Owner.

END OF SECTION

SECTION 26 0923 - OCCUPANCY AND VACANCY SENSORS

PART 1 - GENERAL

1.1 SUMMARY

- A. Work Included:
 - 1. Occupancy/Vacancy Sensors (Ceiling Mounted)
 - 2. Combined Occupancy Sensor/Wall Switches ("Sensor/Switches")
 - 3. Automatic Switches

1.2 RELATED SECTIONS

- A. Contents of Division 26, Electrical and Division 01, General Requirements apply to this Section.

1.3 REFERENCES AND STANDARDS

- A. References and Standards as required by Section 26 00 00, Electrical Basic Requirements and Division 01, General Requirements.

1.4 SUBMITTALS

- A. Submittals as required by Section 26 00 00, Electrical Basic Requirements and Division 01, General Requirements.
- B. In addition, provide:
 - 1. Provide wiring diagrams indicating low voltage and line voltage wiring requirements.
 - 2. Provide, on reproducible architectural floor plan, a layout of sensors indicating their sensing distribution.

1.5 QUALITY ASSURANCE

- A. Quality assurance as required by Section 26 00 00, Electrical Basic Requirements and Division 01, General Requirements.
- B. In addition, meet the following:
 - 1. Use manufacturer's published testing and adjusting procedures to adjust sensors time delay, daylight sensitivity, and passive infrared sensitivity to satisfaction of the Owner.
 - 2. Prepare and complete report of test procedures and results. Submit these test procedures and results to Owner and Architect.

1.6 WARRANTY

- A. Warranty of materials and workmanship as required by Section 26 00 00, Electrical Basic Requirements and Division 01, General Requirements.

PART 2 - PRODUCTS

2.1 MANUFACTURERS

- A. Occupancy/Vacancy Sensors (Ceiling Mounted):
1. Passive Infrared Occupancy/Vacancy Sensors:
 - a. Acuity Controls
 - b. WattStopper
 - c. Leviton
 - d. Hubbell
 - e. Greengate
 - f. Or approved equivalent.
 2. Ultrasonic Occupancy/Vacancy Sensors:
 - a. WattStopper
 - b. Leviton
 - c. Hubbell
 - d. Greengate
 - e. Acuity Controls
 - f. Or approved equivalent.
 3. Dual Technology Occupancy/Vacancy Sensors:
 - a. WattStopper
 - b. Leviton
 - c. Hubbell
 - d. Greengate
 - e. Acuity Controls
 - f. Or approved equivalent.
- B. Combined Occupancy/Vacancy Sensor:
1. Lutron
 2. Acuity Controls
 3. WattStopper
 4. Leviton
 5. Hubbell
 6. Greengate
 7. Or approved equivalent.
- C. Automatic Switches:
1. Acuity Controls
 2. WattStopper
 3. Leviton
 4. Hubbell
 5. Greengate
 6. Or approved equivalent.
- D. Basis of Design: Occupancy/Vacancy sensor layout on Drawings are designed based on WattStopper product line. Approved manufacturers listed are allowed on condition of meeting the specified conditions including complete sensor coverage of the area controlled and switching of luminaires in the area controlled. Provide additional sensors and power switch

packs as needed to provide the same level of functionality as shown on Drawings or required in Specifications. Remove and replace electrical equipment installed not meeting these conditions at no cost to Owner.

2.2 GENERAL

- A. Occupancy sensor designation indicates sensors automatically turn lights ON when the sensor detects the presence of a person and will automatically turn lights OFF when no presence is detected for a specified amount of time (automatic-on and automatic-off).
- B. Vacancy sensor designation requires someone to manually turn the lights ON. The sensor will then automatically turn the lights OFF when no presence is detected for a specified amount of time (manual-on and automatic-off).
- C. Provide occupancy sensors to sense presence of human activity within desired space and enable or disable on/off manual lighting control function provided by local switches.
- D. Upon detection of human activity by detector, sensor initiates time delay to maintain lights on for present period of time. Field adjustable time delay setting from 30 seconds to 15 minutes.
- E. Factory set sensors for maximum sensitivity.
- F. LED lamp built into sensor indicates when occupant is detected.
- G. Provide zero cross relay control with sensors and sensor/switched; relay contacts close and open with AC voltage signal is at zero.
- H. Where line voltage sensors and sensor/switches are used, provide to match voltage of controlled circuit.
- I. Line Voltage Sensors, Control Units, and Relays: UL listed.

2.3 OCCUPANCY/VACANCY SENSORS (CEILING MOUNTED)

- A. Passive Infrared Sensors:
 - 1. Sensor Function: Detects human presence in floor area being controlled by detecting changes in Infrared energy. Sensor detects small movements, i.e., when people are writing while seated at a desk.
 - 2. Provide temperature compensated dual element pyro-electric sensor and with multi element Fresnel lens.
 - 3. Sensor utilizes DIP switches for adjustment to time delay and override. Field adjustable settings for sensitivity.
 - 4. Provide daylight filter to ensure that sensor is insensitive to short-wavelength infrared waves, i.e., those emitted by sun.
 - 5. Adjustments and mounting hardware under removable cover to prevent tampering with adjustments and hardware.
 - 6. Sensor utilizes advanced digital signal processing technology to reduce false offs without reducing sensitivity.
 - 7. Ceiling-Mounted Sensor:
 - a. Programmable to operate as an occupancy sensor (automatic-on and automatic-off) or a vacancy sensor (manual-on and automatic-off).

- b. 360 degree sensor range; coverage: 1200 SF, unless otherwise noted on drawings.
 - c. Low Voltage Sensor: 24VDC power. Sensor operates remote power switch packs. Multiple sensors can be wired in parallel allow coverage of large areas.
 - d. Basis of Design: Wattstopper CI-300 Series.
8. Building Exterior Sensor:
- a. Capable of mounting on walls, eaves or ceilings.
 - b. On/off control based on daylight levels via adjustable light level setting.
 - c. Line Voltage: provide sensor to match voltage of lighting controlled; capable of switching up to 1000 watts ballast and incandescent load.
 - d. Adjustable time delay from 15 seconds to 15 minutes.
 - e. Silicon gasketed to prevent water and dust intrusion. UL listed raintight.
 - f. Rated to operate in temperatures from -40 degrees F to 130 degrees F.
 - g. Provide each sensor with manufacturer supplied wire-guard.
 - h. Provide isolated relay for monitoring by security system
 - i. Coverage:
 - 1) Narrow beam up to 100 foot distance.
 - 2) 90 degree beam up to 50 foot distance.
 - j. Finish: White.
 - k. Basis of Design: Wattstopper EN Series.
- B. Ultrasonic Occupancy/Vacancy Sensors:
1. Sensor Function: Detects human presence in controlled floor area by detecting Doppler shifts in 40kHz ultrasound created by sensor.
 2. Sensors are precision crystal controlled and do not interfere with each other when two or more are placed in same area. Sensor includes advanced digital signal processing to reduce false on signals without decreasing sensitivity, as well as immunity to RFI/EMI sources.
 3. Sensor utilizes DIP switches for adjustment to time delay and override. Field adjustable settings for sensitivity.
 4. Low Voltage Sensor: 24VDC power. Sensor operates remote power switch packs. Multiple sensors can be wired in parallel allow coverage of large areas.
 5. Provide adjustments and mounting hardware under removable cover to prevent tampering.
 6. Ceiling-Mounted Sensor:
 - a. Programmable to operate as an occupancy sensor (automatic-on and automatic-off) or a vacancy sensor (manual-on and automatic-off).
 - b. Maximum protrusion of 1.1-inches and blend in aesthetically with ceiling.
 - c. Coverage: 360 degree sensor range; coverage: 2,000 SF, unless otherwise noted on Drawings.
 - d. Basis of Design: Wattstopper WT Series.
 7. Ceiling Mounted Sensor - Hallway Sensor Coverage:
 - a. Programmable to operate as an occupancy sensor (automatic-on and automatic-off) or a vacancy sensor (manual-on and automatic-off).
 - b. Maximum protrusion of 1.5-inches and blend in aesthetically with ceiling.
 - c. Coverage: 90 linear feet.
 - d. Basis of Design: Wattstopper UT-300-3 Series.
- C. Dual Technology Sensors:

1. Sensor Function: Combined capability of passive infrared with ultrasonic or microphonic technology as described above.
2. Function: Upon a person entering a space, motion must be sensed by both technologies before lighting will be turned on. After this has occurred, detection by either technology will hold lighting on. Sensors retrigger time delay where only one motion is necessary to turn on lights within 5 seconds after turning off.
3. Ceiling-Mounted Sensor:
 - a. Programmable to operate as an occupancy sensor (automatic-on and automatic-off) or a vacancy sensor (manual-on and automatic-off).
 - b. 360 degree sensor range; coverage: 1000 SF for half-step motion, unless otherwise noted on Drawings.
 - c. Low Voltage Sensor: 24VDC power. Sensor operates remote power switch packs. Multiple sensors can be wired in parallel allow coverage of large areas.
 - d. Basis of Design: Wattstopper DT-300 Series.

2.4 COMBINED OCCUPANCY/VACANCY SENSOR/WALL SWITCHES ("SENSOR/SWITCHES")

- A. Completely self-contained sensor system that fits into standard single gang box. Internal transformer power supply, latching dry contact relay switching mechanism compatible with electronic ballasts, compact fluorescent, and inductive loads. Triac and other harmonic generating devices are not allowed.
- B. Passive infrared sensor technology includes advanced signal processing to reduce false triggers without increasing sensitivity. LED indicator blinks when occupant sensed.
- C. Rated to switch loads: 800 watts incandescent or 120-volt ballast; 1000 watts 277 volt ballast. Zero-crossing technology switches lighting off when AC voltage is at zero, minimizes contact wear.
- D. Provide adjustable daylight feature that holds lighting "off" when desired footcandle level is present.
- E. Provide integral off override switch with no leakage current to load or ground.
- F. Vandal-resistant lens.
- G. Includes neutral wire to meet NEC.
- H. Finish: White.
- I. Alerts for impending shut-off: light flash, audible, both or none.
- J. Standard Sensor/Switch:
 1. Programmable to operate as an occupancy sensor (automatic-on and automatic-off) or a vacancy sensor (manual-on and automatic-off). Factory set to manual on/auto off.
 2. 180 degree sensor range; coverage: 150 SF for desktop activity.
 3. Basis of Design: Wattstopper PW-301 Series.
- K. Dual Relay Sensor/Switch:

1. Programmable to operate as an occupancy sensor (automatic-on and automatic-off) or a vacancy sensor (manual-on and automatic-off).
 2. Dual auto-off buttons on face of switch allow end-user to turn off two switch legs in room space. Built-in light adjustable level sensor only turns off second of two relays when desired footcandle level is present. Otherwise similar to specifications above for single-zone sensor/switch.
 3. Defaults to Manual-ON to 50% operation for maximum energy savings.
 4. 180 degree sensor range; coverage: 150 SF for desktop activity.
 5. Finish: White.
 6. Basis of Design: Wattstopper PW-302.
- L. Sensor/Slide Dimmer:
1. Line voltage slider dimmer allows for manual adjustment of lighting levels from 100 percent to 10 percent; compatible with two-wire line voltage 100 percent to 10 percent electronic dimming ballasts. Separate manual button for override 'off' control.
 2. 180 degree sensor range; coverage: 300 SF for desktop activity.
 3. Basis of Design: Wattstopper PW-100D/101D Series.
- M. Passive Infrared Wall Switch Vacancy-Only Sensors:
1. Operates only as a vacancy sensor (manual-on and automatic-off).
 2. Adjustable sensitivity (high, low presets).
 3. Basis of Design: Lutron Maestro MS Series.
- N. Dual Technology Wall Switch Vacancy-Only Sensors:
1. Operates only as a vacancy sensor (manual-on and automatic-off).
 2. Adjustable sensitivity (high, medium, low, and off presets) individually for passive infrared and ultrasonic sensing.
 3. Basis of Design: Lutron Maestro MS Series.
- O. Passive Infrared Wall Dimmer Vacancy-Only Sensors:
1. Operates only as a vacancy sensor (manual-on and automatic-off).
 2. Basis of Design: Lutron Maestro MSCL Series.
- P. Passive Infrared 0-10 V Wall Dimmer Vacancy-Only Sensors:
1. Operates only as a vacancy sensor (manual-on and automatic-off).
 2. Basis of Design: Lutron Maestro 0-10V Dimmer Sensor MS Series.
- ## 2.5 AUTOMATIC SWITCHES
- A. Automatic ("Sentry") Switch:
1. Programmable to operate as an occupancy sensor (automatic-on and automatic-off) or a vacancy sensor (manual-on and automatic-off).
 2. Controls up to 1800 watts at 120-volt, 4100-watts at 277-volt, suitable for ballast and motor loads.
 3. Compatible with Decora style faceplate.
 4. Zero crossing circuitry.
 5. Finish: Match wiring devices unless selected otherwise by Architect.
 6. Capable of being connected with other sentry switches to produce 3 and 4 way switching.
 7. Based on power interruptions of following durations from an upstream control panel, produces following effects:

- a. 5 Seconds: Turns lighting off with no delay.
 - b. 3 Seconds: Turns lighting on with no delay.
 - c. 1 to 2 Seconds: Delayed off. Blinks lights and provides audible signal to room occupant. If switch push button is not pressed within 5 minutes, lights are turned off.
8. Basis of Design: Wattstopper AS-100 Series.
- B. Digital Timer Switch:
1. Controls up to 1800 watts at 120 volt, 4100 watts at 277 volt, suitable for ballast and motor loads.
 2. Compatible with Decora style faceplate.
 3. Provide low voltage (24VAC/VDC) version where used as input to lighting relay panel; includes single-pole, double-throw isolated relay rated for 1A at 30VDC.
 4. Electroluminescent LCD display shows timer countdown.
 5. Time out setting range from 5 minutes to 12 hours. Lights can be turned off before time-out setting by holding down on/off button.
 6. Timer countdown can be reset to beginning by holding down push button for 2 seconds.
 7. Zero crossing circuitry.
 8. Finish: White.
 9. Room lighting flashed and switch beeps 5 minutes and 1 minute prior to switching room lighting off. Either visible or audible features can be disabled.
 10. Basis of Design: Wattstopper TS-400 Series.

PART 3 - EXECUTION

3.1 GENERAL INSTALLATION REQUIREMENTS

- A. Install occupancy/vacancy sensors as directed by manufacturer's instructions. Complete connections to control circuits, occupancy sensors, power supply pack and low voltage wiring.
- B. Provide power packs for sensor to control number of circuits and/or switch legs within its area of coverage.
- C. Field adjust each sensor to maximize its coverage of room space.
- D. Relocate sensors with ultrasonic technology to avoid being closer to HVAC diffusers and power packs than recommended by manufacturer.
- E. Field set time delay for each device as noted below:
 1. Restrooms: 15 minutes.
 2. Storage Rooms, Janitor's Closets, Unisex Restrooms: 5 minutes.
 3. All Other Spaces: 15 minutes.
 4. Time Switches: 2-hours.
- F. Coordinate HVAC control requirements with controls contractor prior to installation.
- G. Lighting System Testing and Commissioning:
 1. Test lighting controls to ensure that control devices, components, equipment and systems are calibrated, adjusted and operate in accordance with Drawings and Specifications. Provide functional testing of sequences of operation to ensure operation in accordance

with Drawings and Specifications. Provide complete report of test procedures and results to engineer and insert approved copy into project closeout documents.

2. Testing includes:
 - a. Daylight Automatic Controls
 - b. Occupant Sensing Automatic Controls
 - c. Automatic Time and Override Controls for Interior Lighting
 - d. Automatic Time and Photo Controls for Exterior Lighting

END OF SECTION

SECTION 26 2416 - PANELBOARDS

PART 1 - GENERAL

1.1 SUMMARY

- A. Work Included:
 - 1. Power Distribution Panelboards
 - 2. Panelboards

1.2 RELATED SECTIONS

- A. Contents of Division 26, Electrical and Division 01, General Requirements apply to this Section.
- B. In addition, reference the following:
 - 1. Section 26 05 73, Electrical Distribution System Studies.
 - 2. Section 26 24 13, Switchboards.
 - 3. Section 26 28 00, Overcurrent Protective Devices.

1.3 REFERENCES AND STANDARDS

- A. References and Standards as required by Section 26 00 00, Electrical Basic Requirements and Division 01, General Requirements.
- B. In addition, meet the following:
 - 1. UL 67, Standards for Panelboards.

1.4 SUBMITTALS

- A. Submittals as required by Section 26 00 00, Electrical Basic Requirements and Division 01, General Requirements.

1.5 QUALITY ASSURANCE

- A. Quality assurance as required by Section 26 00 00, Electrical Basic Requirements and Division 01, General Requirements.

1.6 WARRANTY

- A. Warranty of materials and workmanship as required by Section 26 00 00, Electrical Basic Requirements and Division 01, General Requirements.

PART 2 - PRODUCTS

2.1 MANUFACTURERS

- A. Power Distribution Panelboards:
 - 1. Eaton
 - 2. ABB/General Electric
 - 3. Basis of Design: Schneider Electric/Square D

4. Or approved equivalent.
- B. Panelboards:
1. Eaton
 2. ABB/General Electric
 3. Basis of Design: Schneider Electric/Square D
 4. Or approved equivalent.
- C. Manufacturers listed above are allowed on condition of meeting specified conditions including available space for equipment, Code required working clearances, selective coordination per Section 26 0573, Electrical Distribution System Studies, and amps interrupting capacity (AIC) per short circuit study in Section 26 0573, Electrical Distribution System Studies. Prior to submitting bid, manufacturer to provide documentation to Engineer verifying specific conditions, including those mentioned above, can be met. Remove and replace electrical equipment installed, at no cost to the Owner, that does not meet these conditions.

2.2 POWER DISTRIBUTION PANELBOARDS

- A. Description: NEMA PB 1 Type 1 or as indicated on drawings, circuit breaker type.
- B. Integrated Equipment Rating: Provide fully rated integrated equipment rating greater than the available fault current. Series rated panelboards are not acceptable. Reference drawings for available fault currents. If drawings do not have available fault current shown, then coordinate with serving electrical utility. Final rating based on the protective device study completed under the provisions of Division 26, Electrical Distribution System Studies.
- C. Panelboard Bus: Non-reduced copper, ratings as indicated on drawings. Bus bar with suitable electroplating (tin) for corrosion control at connection. Provide copper ground bus in each panelboard.
- D. Lugs: Mechanical type for both aluminum and copper conductors. All device terminals/lugs shall be rated for a minimum of 75 degrees C to facilitate the use of 75 degrees C conductor ampacity rating.
- E. Molded Case Circuit Breakers: With integral thermal and instantaneous magnetic trip in each pole; UL listed. For air conditioning equipment branch circuits provide circuit breakers UL listed as Type HACR.
- F. Molded Case Circuit Breakers with Current Limiters: With replaceable current limiting elements, in addition to integral thermal and instantaneous magnetic trip in each pole; UL listed.
- G. Circuit Breaker Accessories: Trip units and auxiliary switches as indicated.
- H. Circuit Breakers 1200 Amp and Greater: Provide breaker with energy-reducing maintenance switching with local status indicator per NEC Article 240.87(B).
- I. Fully equip unused spaces for future devices, including manufacturer required connections and mounting hardware.
- J. Cabinet Front: Surface type hinged door with flush lock, metal directory frame, finished in manufacturer's standard gray enamel.

2.3 PANELBOARDS

- A. Description: Panelboards 400 amps or less. NEMA PB1, Type 1 or as indicated on drawings, circuit breaker type. Maximum enclosure depth: 6-inches for surface mounted, 5-3/4-inches for flush mounted.
- B. Maximum Width: 20-inches.
- C. Integrated Equipment Rating: Provide fully rated integrated equipment rating greater than the available fault current. Series rated panelboards are not acceptable. Reference drawings for available fault current. If drawings do not have available fault current shown, then coordinate with serving electrical utility. Final rating based on the protective device study completed under the provisions of Division 26, Electrical Distribution System Studies.
- D. Panelboard Bus Non-Reduced: Copper, ratings as indicated on drawings. Bus bar with suitable electroplating (tin) for corrosion control at connection. Provide copper ground bus in each panelboard.
- E. Lugs: Mechanical type for both aluminum and copper conductors. All device terminals/lugs shall be rated for a minimum of 75 degrees C to facilitate the use of 75 degrees C conductor ampacity rating.
- F. Provide double lugs and/or feed-through lugs for feed through feeders.
- G. Molded Case Circuit Breakers: Thermal magnetic trip circuit breakers, bolt-on type, with common trip handle for poles; UL listed. Predrill bus for bolt-on breakers.
 - 1. Type SWD for lighting circuits.
 - 2. Type HACR for air conditioning equipment circuits.
 - 3. Class A ground fault interrupter circuit breakers where scheduled.
 - 4. Class B ground fault equipment protection circuit breakers for heat trace and other circuits as required by Code. Provide shunt trip circuit breakers where scheduled; provide wiring to remote trip switch/contacts as indicated on Drawings.
 - 5. Do not use tandem circuit breakers.
- H. Accessories: Provide where indicated: shunt trip, arc-fault circuit interrupter (AFCI), Class A ground fault circuit interrupter (GFCI), auxiliary switch, and alarm switch.
- I. Cabinet Front: Provide flush or surface mounting as shown on the schedules, drawings, or otherwise noted. Cabinet front with concealed hinged front cover construction, metal directory frame with heavy clear plastic protector, flush lift latch and lock, two keys per panel all keyed alike.
- J. Provide boxes with removable blank end walls and interior mounting studs. Provide interior support bracket for ease of interior installation.
- K. Furnish surface mounted cabinet boxes without knockouts.

PART 3 - EXECUTION

3.1 GENERAL INSTALLATION REQUIREMENTS

- A. Install panelboards in accordance with NEMA PB 1.1, NECA 1 and manufacturers installation instructions.
- B. Install panelboards level and plumb. Install recessed panelboards flush with wall finishes.
- C. Height: 6-feet 6-inches to top of panelboard; install panelboards taller than 6-feet 6-inches with bottom no more than 4-inches above floor.
- D. Provide filler plates for unused spaces in panelboards.
- E. Provide typed circuit directory for each branch circuit panelboard. Include all "spaces" and "spares." Revise directory to reflect circuiting changes and as-installed conditions. Use final Owner designated room names and numbers, and not designations shown on drawings.
- F. Provide engraved plastic nameplates per Section 26 05 53, Identification for Electrical Systems.
- G. Provide arc flash labels per Section 26 0573, Electrical Distribution System Studies.
- H. Provide concrete housekeeping pad for floor-mounted distribution panelboards. Extend 6-inches beyond distribution panel width and depth dimensions. Minimum 3-inches above finished floor. Install plumb and level.
- I. Provide two 1-inch spare conduits out of each recessed panelboard to an accessible location above ceiling. Identify each as SPARE.
- J. Provide permanent identification number in or on panelboard dead-front adjacent to each breaker pole position. Horizontal centerline of numbers to correspond with centerline of circuit breaker pole position.
- K. Ground and bond panelboard enclosure per NEC.
- L. Paint:
 - 1. Standard factory finish unless noted otherwise.
 - 2. Panelboards located in finished interior areas in view of building occupants; paint to match adjacent wall surface. Color and paint preparation as specified by Architect. Covers to be painted off wall, then installed over dried, painted wall surface.
- M. Provide handle guards on each circuit supplying obviously constant loads such as fire alarm, security, lighting controls, refrigerators and freezers, fire protection, etc.
- N. Provide interior wiring diagram, neutral wiring diagram, UL label, and short circuit rating on interior or in booklet format inserted in sleeve inside panel cover.
- O. Verify available recessing depth and coordinate wall framing with other divisions.
- P. Maintain fire rating of wall where panels are installed flush in fire rated walls.

- Q. Perform inspections and tests in accordance with manufacturer's requirements.
- R. Thoroughly clean exterior and interior of each panelboard in accordance with manufacturer's installation instructions.
- S. Vacuum construction dust, dirt, and debris out of each panelboard.
- T. Where enclosure finish is damaged, touch up finish with matching paint in accordance with manufacturer's specifications and installation instructions.
- U. Reference Section 26 08 05, Electrical Acceptance Testing for testing requirements.

3.2 POWER DISTRIBUTION PANELBOARDS INSTALLATION

- A. Breakers being added to existing panelboards: Coordinate breaker type and short circuit rating with existing panelboard. Breakers to match existing in manufacturer's type and AIC rating. Provide new typed circuit directory.
- B. Provide handle tie to branch circuit breakers of multiwire branch circuits for simultaneous disconnection of circuits. Handle tie will be identified for use with circuit breakers provided. Reconfigure assigned circuits as necessary so that circuit breakers associate with multiwire branch circuits are physically adjacent, record changes in panelboard schedules and circuiting plans for record drawings.
- C. Shunt Trip Circuit Breakers: Provide wiring to remote trip switch/contacts as indicated on Drawings.
- D. Measure steady state load currents at each panelboard feeder; rearrange circuits in panelboard to balance phase loads to within 20 percent of each other. Maintain proper phasing for multi-wire branch circuits.

3.3 PANELBOARDS INSTALLATION

- A. Breakers being added to existing panelboards: Coordinate breaker type and short circuit rating with existing panelboard. Breakers to match existing in manufacturer's type and AIC rating. Provide new typed circuit directory.
- B. Provide handle tie to branch circuit breakers of multiwire branch circuits for simultaneous disconnection of circuits. Handle tie will be identified for use with circuit breakers provided. Reconfigure assigned circuits as necessary so that circuit breakers associate with multiwire branch circuits are physically adjacent, record changes in panelboard schedules and circuiting plans for record drawings.
- C. Shunt Trip Circuit Breakers: Provide wiring to remote trip switch/contacts as indicated on Drawings.

- D. Measure steady state load currents at each panelboard feeder; rearrange circuits in panelboard to balance phase loads to within 20 percent of each other. Maintain proper phasing for multi-wire branch circuits.

END OF SECTION

SECTION 26 2713 - ELECTRICAL METERING

PART 1 - GENERAL

1.1 SUMMARY

- A. Work Included:
 - 1. Utility Metering Equipment
 - 2. Energy Metering
 - 3. Power Quality Metering

1.2 RELATED SECTIONS

- A. Contents of Division 26, Electrical and Division 01, General Requirements apply to this Section.

1.3 REFERENCES AND STANDARDS

- A. References and Standards as required by Section 26 00 00, Electrical Basic Requirements and Division 01, General Requirements.

1.4 SUBMITTALS

- A. Submittals as required by Section 26 00 00, Electrical Basic Requirements and Division 01, General Requirements.

1.5 QUALITY ASSURANCE

- A. Quality assurance as required by Section 26 00 00, Electrical Basic Requirements and Division 01, General Requirements.

1.6 WARRANTY

- A. Warranty of materials and workmanship as required by Section 26 00 00, Electrical Basic Requirements Division 01, General Requirements.

PART 2 - PRODUCTS

2.1 MANUFACTURERS

- A. Manufacturers:
 - 1. Utility Metering Equipment
 - a. Meter Base:
 - 1) Circle AW.
 - 2) Or approved equivalent.
 - b. Metering Equipment Enclosure:
 - 1) ABB/General Electric
 - 2) Schneider Electric/Square D
 - 3) Eaton Electrical
 - 4) Or approved equivalent.
 - 2. Energy Metering

- a. E-Mon D-Mon Class 2000D or 3000 with ModBus Communications Series.
 - b. Or approved equivalent.
3. Power Quality Metering
- a. Schneider Electric/Square D Powerlogic Series
 - b. Or approved equivalent.

2.2 UTILITY METERING EQUIPMENT

- A. Meter Base: Surface or Flush mounted meter socket enclosure. Provide meter base(s) for energy/demand and reactive energy/demand bases as required by serving electric utility.
- B. Terminal Cabinet: Provide terminal cabinet that meets serving utility company's requirements. Construct as an integral part of main distribution switchboard.
- C. Provide fault withstand rating greater than utility determined available fault current.
- D. C.T. Enclosure: Provide enclosure that meets serving utility company's requirements. Construct as an integral part of main distribution switchboard.

2.3 ENERGY METERING

- A. Provide fully electronic meter with cycling 8-digit LCD display for energy consumption (kWh), current and peak load (kW). Meter includes rate of consumption indication and segment test button to ensure integrity of display.
- B. Energy Consumption: Meter to indicate real time power consumption levels for field-testing and certification. Manually reset to zero.
- C. Enclosure: Heavy duty JIC steel enclosure suitable for indoor installation, lockable for preventing unauthorized access.
- D. Operating Parameters:
 1. Voltage: Up to 600 volts rms AC available.
 2. Current: Up to 3200 amps rms AC available.
 3. Power Factor: 0.5 lagging to 0.5 leading.
 4. Frequency: 50 to 60 Hz.
 5. Voltage Operating Range: Plus or minus 25 percent of rated voltage.
 6. Temperature Range: Minus 20C to plus 50C.
 7. Humidity: 0 to 95 percent non-condensing.
 8. Voltage Overload: Plus 25 percent continuous, plus 100 percent for 20 cycles.
 9. Current Overload: Plus 100 percent without damaging meter.
- E. Current and Peak Load: Supply meter with demand (Kw) reading. Demand reading to show highest peak demand and date and time peak occurred.
- F. Sampling: 15 or 30 minute demand interval (factory default: 15 minutes).
- G. Integral self-contained back-up system to maintain memory and display during power failures.

- H. 0-2V voltage output current sensors to allow paralleling and/or mounting up to 2000-feet from meter. Split core type sensor configuration to allow installation without powering down.
- I. Standards: UL listed; compliant with ANSI C12.1 and C12.16 specifications with split-core current sensors.
- J. Provide meter with following auxiliary device for interfacing to energy management system: digital to analog converter: 0 to 10Vdc or 4 to 20mA, pulser module: 4.5 to 28Vdc, or ModBus communications.
- K. Include a submeter with voltage, current and wire-configuration (2-, 3- or 4-wire, single or three-phase, grounded and undergrounded) as required on drawings.
- L. Conductors from current sensors and conductors for monitoring line voltage can be run in same conduit.

2.4 POWER QUALITY METERING

- A. Power Meters:
 - 1. Current/Voltage Inputs:
 - a. Energy Monitoring System (EMS) power meter with no less than 4 voltage inputs and 5 current inputs
 - b. EMS power meter in its standard configuration capable of accepting 600VAC LL / 347VAC LN without using potential transformers.
 - c. EMS power meter is capable of withstanding 1500 VAC RMS continuously without damaging device.
 - d. EMS power meter is capable of nominal current ratings of 1A, 2A, 5A, 10A, and/or 20A and an overcurrent rating of 500A for 1s (5A nominal model) or 200A for 1s (1A nominal model).
 - 2. Measured Values:
 - a. Minimum Voltage Values:
 - 1) Voltage L-L Per-Phase.
 - 2) Voltage L-L 3-Phase Avg.
 - 3) Voltage L-N Per-Phase.
 - 4) Voltage 3-Phase Avg.
 - 5) Voltage percent unbalanced.
 - b. Minimum Current Values:
 - 1) Current Per-Phase.
 - 2) Current, Neutral (measured).
 - 3) Current 3-Phase Avg.
 - 4) Current percent Unbalanced.
 - c. Minimum Power Values:
 - 1) Real Power (Per-Phase, 3-Phase Total).
 - 2) Reactive Power (Per-Phase, 3-Phase Total).
 - 3) Apparent Power (Per-Phase, 3-Phase Total).
 - 4) Power Factor - True (Per-Phase, 3-Phase Total).
 - 5) Power Factor - Displacement (Per-Phase, 3-Phase Total).
 - d. Minimum Energy Values:

- 1) Accumulated Energy (Real kWh, Reactive kVARh, Apparent kVAh) (Signed/Absolute).
 - 2) Incremental Energy (Real kWh, Reactive kVARh, Apparent kVAh) (Signed/Absolute).
 - 3) Conditional Energy (Real kWh, Reactive kVARh, Apparent kVAh) (Signed/Absolute).
 - 4) Reactive Energy by Quadrant.
 - e. Minimum/maximum value for any measured parameter.
 - f. Capable of deriving values for any combination of measured or calculated parameter, using following arithmetic, trigonometric, and logic functions (or equivalent PLC capabilities):
 - 1) Arithmetic functions: division, multiplication, addition, subtraction, power, absolute value, square root, average, max, min, RMS, sum, sum-of-squares, unary minus, integer ceiling, integer floor, modulus, exponent, PI.
 - 2) Trigonometric functions: COS, SIN, TAN, ARCCOS, ARCSIN, ARCTAN, LN, LOG10.
 - 3) Logic functions: =, =>, <=, , <, >, AND, OR, NOT, IF.
 - 4) Thermocouple linearization functions: Type J, Type K, Type R, Type RTD, Type T.
 - 5) Temperature conversion functions: C to F, F to C.
3. Demand:
 - a. Minimum/maximum demand, present demand interval, running average demand, and predicted demand on multiple demand channels.
 - b. Perform multiple accepted demand calculation methods including block, rolling block, and thermal demand with user-programmable demand period lengths.
 4. Accuracy:
 - a. Meeting ANSI C12.20 accuracy class 0.2.
 - b. Meeting IEC62053-22: Electricity metering equipment (AC) -particular requirements -part 22: Static meters for active energy, accuracy class 0.2S.
 - c. Meeting IEC62053-23: Electricity metering equipment (AC) - particular requirements -part 23: Static meters for reactive energy, accuracy class 1.
 - d. 4-quadrant metering.
 5. Sampling:
 - a. Sample at 256 samples/cycle.
 - b. Perform high speed sag/swell detection of voltage disturbances on a cycle-by-cycle basis, providing duration of disturbance, minimum, maximum, and average value of voltage for each phase during disturbance. Disturbances less than one cycle in duration can be detected.
 6. Logging:
 - a. Minimum 5MB of user programmable onboard data logging.
 - b. EMS store all critical internal and revenue data upon sudden power loss.
 - c. Non-volatile memory.
 - d. Time-stamped event log with following features:
 - 1) Supports at least 500 events.
 - 2) Number of records in log is programmable.
 - 3) Each event is recorded with date and time of event, cause and effect of event, and priority of event.
 - 4) Events relating to setpoint activity, relay operation and self-diagnostics is recorded in event log.

- 5) Time stamps have a resolution of 1 millisecond.
 - 6) Time stamps can be synchronized to within 100 ms between devices on same serial communications medium.
 - 7) Minimum event recording response time is 1/2 cycle (8.3ms 60Hz, 10ms 50Hz) for high speed events and 1 second for other events.
 - 8) Priority of setpoint events is programmable.
 - e. Log any parameter in meter including min/max and waveforms.
7. Alarming:
- a. Setpoint driven alarming capability.
 - b. Generates an email on an alarm condition.
 - c. Millisecond timestamp resolution on alarm entries.
 - d. Capable readjusting alarm setpoints based on alarm quantity (Alarm Setpoint Learning).
 - e. Support consecutive high-speed alarm conditions which trigger on a cycle-by-cycle basis with no “dead” time between events (i.e., no need for a rearming delay time between events).
 - f. Capable of operating relays on alarm conditions.
 - g. Capable of initiating datalog captures on alarm conditions.
 - h. Capable of controlling digital output relays in an AND or an OR configuration, using pulse mode or latch mode operation, for control and alarm purposes.
 - i. Capable of combing any logical combination of any number of available setpoint conditions to control any internal or external function or event.
8. Communications:
- a. Capable of communications methods simultaneously and independently: Ethernet over Fiber or copper media.
 - b. Can support any one of following communications protocols on any one port at any one time:
 - 1) ION
 - 2) Ethergate
 - 3) Modemgate
 - 4) DNP 3.0
 - 5) SMTP
 - 6) SNTTP
 - 7) MV-90 compatibility
 - 8) XML compatibility
 - 9) SNMP
 - 10) HTTP (web pages)
 - c. Can support GPS time synchronization.
 - d. Equipped with an Ethernet port are internet enabled and supports following functions:
 - 1) Automatically e-mail alarm notifications or scheduled system status updates. E-mail messages sent by EMS power meters can be received like any ordinary e-mail message. Data logs can also be sent on an event-driven or scheduled basis.
 - 2) Built in web pages in EMS power meters enables access to real-time values and basic power quality information using a standard web browser. Basic configuration of EMS power meters can also be performed through browser.
 - 3) Integration with custom reporting, spreadsheet, database and other applications with XML compatible data.

9. I/O Options:
 - a. Capable of having 16 digital inputs capable of 1/2 cycle timing resolution.
 - b. Digital outputs that support pulse output relay operation for kWh total, kWh imported, kWh exported, kVARh total, kVARh imported, kVARh exported, and kVAh values.
 - c. 3 Form C relays which are isolated for up to 5000 VAC for 1 minute and 10A continuous for 30VDC and up to 240VAC.
 - d. 4 Form A analog inputs which are optically isolated.
 - e. 4 analog outputs with a 0-20mA range.
10. Display:
 - a. 320 x 240 pixel LCD display.
 - b. Capable of supporting direct display of all parameters on front panel.
 - c. Capable of adding trend display of any parameter internally recorded at regular intervals.
 - d. User programmable custom display that is capable of displaying up to 20 quantities on single screen.
 - e. Capable of displaying advanced graphical representations of metering information including at minimum spectral components, phasor diagrams, and trending charts.
 - f. Capable of displaying measurements in either IEC or IEEE formats.
 - g. Capable of displaying following front panel screens:
 - 1) Numeric: Display 2, 3, 3 with timestamp, 4, 8, 10, or 20 parameters at a time.
 - 2) Event Log: Display recent events written to EMS power meter's event log, including diagnostic events.
 - 3) Nameplate: Display information in tabular format (default nameplates show Owner, meter and power system details).
 - 4) Trend Bar: Display up to 4 real time numeric parameters along with their upper and lower extremes.
 - 5) Histogram: Display harmonics content in histogram format, including 2nd to 63rd harmonic, THD (total, even, odd); current harmonics histogram screens display K Factor and Crest Factor.
 - 6) Phasor: Display phase information in phasor diagram format, including phase, voltage and current magnitudes; phasors that are too small in magnitude are shown as table entries only.
11. Field Programmability:
 - a. Capable of being field programmable as follows:
 - 1) Basic parameters: Voltage input scale, voltage mode (Wye, Delta, single phase), current input scale, auxiliary input and output scales, and communications setup parameters are programmable from front panel.
 - 2) Basic parameters described above, plus additional setpoint/relay and data log setup parameters may be programmed via communications port using portable or remotely located computer terminal.
 - 3) Custom configuration of operating parameters is possible through graphical, flexible programming language.
 - 4) Configuration of device using programmable modules. Modules can be linked together in an arbitrary manner to create arbitrary functionality. Some example module types include min, max, setpoint, digital input, and digital output.
 - 5) Programming through computer secured by user ID and password.

- 6) Programming through front panel is secured by password.
 - 7) Programmability sectioned such that when meter is sealed, meter can still be configurable to an extent that does not affect accumulation of revenue metering related data.
12. Advanced Features:
- a. Field upgradeable.
 - b. Onboard meter clock can be paced by a choice of sources including GPS, power line, or internal clock.
 - c. Multi-level security which supports customized access for up to 16 users.
 - d. Revenue security capabilities including but not limited to following:
 - 1) Password protected, no hardware lock, or
 - 2) Password protected and hardware locked, or
 - 3) Following data is protected from alteration when locked:
 - (a) kWh and kVARh (import, export, net and total)
 - (b) kVAh (total)
 - (c) kW, kVAR, kVA demand (thermal and sliding window)
 - (d) kWh, kVARh, kVAh pulse outputs
 - e. Provisions for conformal coating of its internal circuitry for installations exposed to high degrees of humidity. (Tropicalization treatment).
 - f. Provisions for creating periodic or non-periodic schedules for up to two (2) years. These schedules may be used to perform following functions:
 - 1) Time of Use (TOU)
 - 2) Demand Control
 - 3) Load Scheduling
 - 4) Logging
 - 5) Periodic Resetting
 - 6) Alarm Gating
 - g. Multiple tariffs and Time-of-Use (TOU) functionality to store and monitor up to 20 years of seasonal rate schedules. TOU feature allows four seasons, four day types (each one capable of at least eight switch times, with resolution of one minute). TOU feature supports four rate tariffs, and at least twelve holidays per year, and allows periodic self-read capability.
 - h. Capable of determining (with a level of confidence) whether a disturbance event occurred upstream or downstream of meter. (Disturbance Direction Detection).
 - i. Supporting two languages without having to upgrade its firmware.
 - j. Supporting trending and forecasting of logged data values feature both on meter display and via webpages.
- B. Factory-Assembled Meter Enclosures:
1. UL listed pad-lockable NEMA 12 enclosure.
 2. Engraved nameplates: White lettering on black phenol background. Example: "Meter M7."
 3. Dimensions: 20-inches high by 16-inches wide by 12-inches deep. Exception: provide larger enclosure as required to integrate main meter and sub-meters where more than one meter is used in an area to monitor total power consumption for one building.
 4. Three-pole fusible disconnect for protection of meters in enclosure.
 5. Control power for meter derived directly from meter voltage inputs.
 6. CT shorting block: Six pole CT shorting block to accommodate 3 CTs per meter.

7. Digital and Analog I/O wiring: 8 DI's, 4 DO's and 3 relay outputs wired to terminal blocks.
8. Communication wiring: one 100BaseT Ethernet and one 100BaseFL equipped meter. COM1 and COM2 wired to 6 terminal blocks (3-IN, 3-OUT each COM port) for 12TBs total.

C. Split-Core CTs:

1. Construction: Directional silicon steel used for flexible core. Open split-core with manual twisting motion. Secondary windings: Copper. Unit enclosed in silicone rubber. Remains flexible from minus 45C to 200C.
2. Output at rated current: 5 amps AC.
3. Insulation level: 600VAC, BIL 10kV full wave.
4. Frequency: 50 to 60Hz.
5. Temperature range: minus 15C to 60C.
6. Humidity range: 0 to 95 percent non-condensing
7. Leads: UL 1015, 105C, 18-AWG, 24-inches long.
8. Thermal factor: 1.00 at 30C.
9. Accuracy: 1 percent for 200:5 to 1600:5 ratio.
10. Burden capacity: 2.5VA at 200:5 ratio; 22.5VA at 1600:5 ratio.
11. Basis of Design: Veris H6810 series.

D. Software:

1. Data base software with graphic user interface (GUI) to allow Owner to query for electrical power and energy consumption information, and steam consumption on mass flow rate, on building-by-building basis for requested time periods. Program software to allow Owner to direct compare buildings on tabular and graphical basis. Hyperlinks within software to allow Owner to then see meter-by-meter contribution to total building energy consumption.
2. Data queries that require Owner to determine total building energy consumption by reading separate meters and summing their results by hand or in Excel is not acceptable.
3. Example of required data queries:
 - a. Query for March 2008 to April 2009:
 - 1) Peak power demand (kW) for Gentle, Barnam and Landers Halls.
 - 2) Total energy consumption (kW-hr) for Gentle, Barnam and Landers Halls.
 - 3) Total steam consumption (lbs) for Gentle, Barnam and Landers Halls.
 - 4) Temperature (F) for return steam condensate for Gentle, Barnam and Landers Halls.
 - 5) Tabular and bar/line graph representation of peak power demand on day-by-day basis for each of these buildings. Provide overlay of three halls.
 - 6) Tabular and bar/line graph representation of total energy consumption on day-by-day basis for each of these buildings. Provide overlay of three halls.
 - 7) Tabular and bar/line graph representation of steam condensate flow rates on day-by-day basis for each of these buildings. Provide overlay of three halls.
 - 8) Tabular and bar/line graph representation of steam condensate temperature on day-by-day basis for each of these buildings. Provide overlay of three halls.
 - 9) Point-and-click to see hourly or 15-minute window power demand, energy consumption, steam consumption, condensate return temperature information for same three halls.

- 10) Building sites can be selected for cross-comparison using a selection menu. Owner should not have to type building names by hand with exact spelling.
- b. Query for 30 March 2009:
 - 1) Tabular and bar/line graph representation of total, real and reactive power, current and voltage for meter at Barnam Hall on 15-minute window basis over 24-hour period. Be capable of switching between different electrical parameters using hyperlinks or pull down menus.
 - 2) Switch to viewing another date by entering value at hyperlink or pull down menu.
 - 3) Change to another date range (weekly, monthly, annual or specified range) by using hyperlink or pull down menu.
- c. Reports: Provide report results output to HTML, Excel, and PDF formats for queries for Owner use.
- d. Interaction screen for a given building, when doing single building queries, will also show:
 - 1) Partial building floor plan indicating meter location(s).
 - 2) Partial building one-line diagram indicating meter location(s) in power distribution system.
4. Software Licenses: Provide following:
 - a. ION Enterprise base, device and client licenses.
 - b. Integrated SQL server 2005 option: processor license for one CPU.
5. Software Development: Provide 3-4 weeks factory programming for following tasks:
 - a. Screen development for main menu.
 - b. Screen development for site plan.
 - c. Screen development for one-lines.
 - d. Steam meter integration.

PART 3 - EXECUTION

3.1 UTILITY METERING INSTALLATION

- A. Meter Bases: Locate to provide acceptable access for meter reading and maintenance. Locate to minimize risk of physical damage.
- B. Metering Equipment: Install current transformers supplied by serving electric utility.
- C. Verify utility requirements prior to bidding and provide associated work required by local utility including but not limited to:
 1. Service underground primary including conduit, pull cord, excavation and backfill.
 2. Underground pull vaults.
 3. Pole risers.
 4. Transformer pads, and vaults.
 5. Secondary service lateral raceways.
 6. Grounding of transformers.
 7. Service metering equipment.

3.2 ENERGY METERING INSTALLATION

- A. Submetering Equipment:
 1. Cabling between current and voltage sensors and meter display enclosure.

2. One-hour video recorded training period for Owner in use of meter.
3. Blank engraved phenol label with white lettering for each meter, listing load monitored (e.g., "Panel A," "Chiller #3," etc.). Use red label with white lettering where load is on generator backup.
4. Commons multiple meter unit cabinet with blank spaces where multiple meters are mounted as shown on one-line diagram and/or floor plans (e.g., 8 meter cabinet with 3 blank spaces where 5 meters are shown in common location).
5. Cabling between meter display enclosure and auxiliary device for communication to energy management system.
6. ModBus cabling between meters, and from meter to energy management system.

3.3 POWER QUALITY METERING INSTALLATION

- A. Install PTs and CTs in accordance with manufacturer instructions. Separate NEMA 1 enclosure for CTs and splicing and extension of existing feeder cables where existing power distribution equipment has insufficient space for installation of split-core CTs.
- B. Use irreversible compression long-barrel butt splices for splicing of feeder cables where needed; tape splices in minimum of three layers of electrical tape with 1000VAC insulation rating.
- C. Field Quality Control:
 1. Provide on-site testing and startup of metering led by factory technician. Field testing by electrician is not acceptable and will be repeated by factory technician at no cost to Owner.
 2. Provide Owner with copy of factory test report.
 3. Factory-approved testing of metering equipment is required prior to start of software commissioning phase. Commissioning work performed prior to completed testing and troubleshooting of power meters will be repeated at no cost to Owner.
- D. Software Configuration and Commissioning: Minimum of 40-hours of on-site software configuration and commissioning with direct Owner involvement. Use time to configure presentation of data in response to queries to satisfaction of Owner.
- E. System Training:
 1. Onsite customer system training for minimum 8-hour duration. Provide Owner with minimum 30-days notice prior to scheduled training so Owner has time to notify staff of training date, and provide videotaped coverage of training. Training must be by factory technician; training by installing electrician is not acceptable.
 2. Schedule this training for no less than 30 days after date of Owner signed acceptance of installation, including software.
 3. Provide Owner with minimum 30-days notice prior to scheduled training so Owner has time to notify staff of training date, and provide videotaped coverage of training.
 4. Provide transcript of factory training for Owner's staff.

END OF SECTION

SECTION 26 2726 - WIRING DEVICES

PART 1 - GENERAL

1.1 SUMMARY

- A. Work Included: Provision of materials, installation and testing of:
 - 1. Wall Switches
 - 2. Receptacles
 - 3. Finish Plates
 - 4. Wall Dimmers
 - 5. Surface Covers

1.2 RELATED SECTIONS

- A. Contents of Division 26, Electrical and Division 01, General Requirements apply to this Section.

1.3 REFERENCES AND STANDARDS

- A. References and Standards as required by Section 26 00 00, Electrical Basic Requirements and Division 01, General Requirements.

1.4 SUBMITTALS

- A. Submittals as required by Section 26 00 00, Electrical Basic Requirements and Division 01, General Requirements.
- B. In addition, provide:
 - 1. Wall switches
 - 2. Receptacles
 - 3. Wall Plates
 - 4. Dimmers
 - 5. In-Use Cover

1.5 QUALITY ASSURANCE

- A. Quality assurance as required by Section 26 00 00, Electrical Basic Requirements and Division 01, General Requirements.

1.6 WARRANTY

- A. Warranty of materials and workmanship as required by Section 26 00 00, Electrical Basic Requirements and Division 01, General Requirements.

PART 2 - PRODUCTS

2.1 MANUFACTURERS

- A. Wall Switches:
 - 1. Toggle Type Characteristics:

- a. Cooper AH1201
 - b. Hubbell HBL1221
 - c. Leviton 1221
 - d. Legrand P&S PS20AC1
 - e. Or approved equivalent.
2. Decorative AC Rocker Switch Characteristics:
 - a. Cooper
 - b. Hubbell
 - c. Leviton
 - d. Legrand P&S
 - e. Or approved equivalent.
- B. Receptacles:
1. Industrial Grade:
 - a. Cooper 5362
 - b. Hubbell HBL5362
 - c. Bryant BRY5362
 - d. Leviton 5362
 - e. Legrand P&S 5362A
 - f. Or approved equivalent.
 2. Commercial Grade:
 - a. 20 Amp:
 - 1) Cooper 5362
 - 2) Hubbell 5362
 - 3) Bryant CBRS20
 - 4) Leviton 5362S
 - 5) Legrand P&S 5362
 - 6) Or approved equivalent.
 3. Ground Fault Circuit Interrupter (GFCI) Receptacle - 20 Amp:
 - a. Cooper WRSGF20W
 - b. Hubbell GFR5362SGW
 - c. Legrand P&S 2097TRWR
 - d. Or approved equivalent.
- C. Finish Plates:
1. Bryant
 2. Cooper
 3. Hubbell
 4. Leviton
 5. Legrand P&S
 6. Or approved equivalent.
- D. Wall Dimmers:
1. Lutron Maestro Series
 2. Or approved equivalent.
- E. Surface Covers:
1. Aluminum with Gasket, Blanks, Single Gang:
 - a. Bell 240-ALF

- b. Carlon
- c. Or approved equivalent.
- 2. 2-Gang:
 - a. Bell 236-ALF
 - b. Carlon
 - c. Or approved equivalent.
- 3. While-in-Use Weatherproof Cover:
 - a. Die Cast Cover:
 - 1) Intermatic
 - 2) Hubbell
 - 3) Cooper
 - 4) Or approved equivalent.

F. Provide lighting switches and receptacles of common manufacturer and appearance.

2.2 WALL SWITCHES

- A. Characteristics: Toggle type, quiet acting, 20 amp, 120/277 volt, UL listed for motor loads up to 80 percent of rated amperage, extra heavy duty.
- B. Finish: White.

2.3 RECEPTACLES

- A. Duplex Receptacles Characteristics: Straight parallel blade, 125 volt, 2 pole, 3 wire grounding.
 - 1. Commercial Grade: Riveted. Back and side wired. Brass ground contact on steel strap. Nylon face and nylon base. 20 amp.
- B. Ground Fault Circuit Interrupter (GFCI) Receptacle: Feed through type, back-and-side wired, tamper-resistant, weather resistant self-testing, 20 amp, 125VAC.
- C. Special Purpose Receptacles: Reference Drawings for NEMA Standard Specification.
- D. Finish:
 - 1. Same exposed finish as switches.
 - 2. Receptacles installed in surface raceway to match raceway finish. See Section 26 05 33, Raceways.
 - 3. All automatically controlled, nonlocking type, 125 volt, 15 amp and 20 amp rated receptacles to be permanently marked by the manufacturer with the "universal power" symbol and the word "controlled."

2.4 FINISH PLATES

- A. Finish Plates: Type 302 stainless steel with smooth satin finish.
- B. Provide telephone/signal device plates; activated outlets to have coverplates to match modular jack.

2.5 WALL DIMMERS

- A. Provide wall dimmers compatible with type of load controlled (i.e. line voltage, low voltage, 2-wire, 3-wire, 0-10v). Finish to match wall switches. Size dimmers to accept connected load. Do not cut fins. Where dimmers are ganged together, provide a single multi gang coverplate.
- B. LED indicator dots show by what percentage controlled lighting is dimmed. Programmable settings for maximum and minimum trim settings, and rate of change in lighting levels.

2.6 SURFACE COVERS

- A. Material: Galvanized steel, drawn, 1/2-inch raised industrial type with openings appropriate for devices installed on surface receptacles.
- B. Cast Box and Extension Adaptors: Aluminum with gasket, blanks single gang or 2-gang.
- C. While-in-Use Weatherproof Cover: NEMA 3R when closed over energized plug. Vertical mount for duplex receptacle. Provide continuous use cover with cover capable of closing over energized cord cap with bottom aperture for cord exit.
 - 1. Die cast cover with closed cell neoprene foam gasket: Capable of being locked closed to prevent tampering or unauthorized use.

PART 3 - EXECUTION

3.1 GENERAL INSTALLATION REQUIREMENTS

- A. See Architectural elevations for location and mounting height of wiring devices. Review Architectural elevations prior to rough-in and contact Architect immediately if conflicts are found between Architectural and Electrical Drawings. Do not rough-in devices until conflicts are resolved.
- B. Install wiring devices and finish plates plumb with building lines, equipment cabinets and adjacent devices. Devices not plumb will be fixed at no additional cost to Owner.
- C. Orientation:
 - 1. Install wiring devices with long dimension oriented vertically at centerline height shown on drawings or as specified.
 - 2. Vertical Alignment: When more than one device is shown on drawings in close proximity to each other, but at different elevations, align devices on a common vertical center line for best appearance. Verify with Architect.
 - 3. Horizontal Alignment: When more than one device is shown on drawings in close proximity to each other with same elevation, align devices on a common horizontal center line for best appearance. Verify with Architect.
- D. Provide labeling per Section 26 05 53, Identification for Electrical Systems.
- E. Test wiring devices to ensure electrical continuity of grounding connections, and after energizing circuitry, to demonstrate compliance with requirements. Test receptacles for line to neutral, line to ground and neutral to ground faults. Correct any defective wiring.

3.2 WALL SWITCHES INSTALLATION

- A. At time of substantial completion, replace those items which have been damaged.

3.3 RECEPTACLES INSTALLATION

- A. Upon installation, adhere to proper and cautious use of convenience receptacles. At time of substantial completion, replace those items which have been damaged, including those burned and scored by faulty receptacles or cord caps.
- B. GFCI Receptacles: One GFCI receptacle may not be used to provide GFCI protection to downstream duplex receptacles on the same branch circuit.

3.4 FINISH PLATES INSTALLATION

- A. Do not install items until finish painting is complete. Replace scratched and paint splattered finish plates and wiring devices.

3.5 WALL DIMMERS INSTALLATION

- A. Install per manufacturer's recommendations and wiring diagrams.

3.6 SURFACE COVERS INSTALLATION

- A. Do not install items until finish painting is complete. Replace scratched and paint splattered finish plates and wiring devices.

END OF SECTION

SECTION 26 2800 - OVERCURRENT PROTECTIVE DEVICES

PART 1 - GENERAL

1.1 SUMMARY

- A. Work Included:
 - 1. Fuses
 - 2. Molded Case Circuit Breakers
 - 3. Fuse Cabinets

1.2 RELATED SECTIONS

- A. Contents of Division 26, Electrical and Division 01, General Requirements apply to this Section.

1.3 REFERENCES AND STANDARDS

- A. References and Standards as required by Section 26 00 00, Electrical Basic Requirements and Division 01, General Requirements.

1.4 SUBMITTALS

- A. Submittals as required by Section 26 00 00, Electrical Basic Requirements and Division 01, General Requirements.
- B. In addition, provide:
 - 1. Product data and instantaneous let-through current curves and average melting time current curves for fuses supplied to project.
 - 2. Product data and time/current trip curves for circuit breakers supplied to project.

1.5 QUALITY ASSURANCE

- A. Quality assurance as required by Section 26 00 00, Electrical Basic Requirements and Division 01, General Requirements apply to this Section.

1.6 WARRANTY

- A. Warranty of materials and workmanship as required by Section 26 00 00, Electrical Basic Requirements and Division 01, General Requirements.

PART 2 - PRODUCTS

2.1 MANUFACTURERS

- A. Fuses:
 - 1. Bussmann
 - 2. Ferraz-Shawmut
 - 3. Littelfuse
 - 4. McGraw-Edison
 - 5. Or approved equivalent.

- B. Molded Case Circuit Breakers:
 - 1. Eaton Electrical
 - 2. ABB/General Electric
 - 3. Schneider Electric/Square D
 - 4. Or approved equivalent.

- C. Fuse Cabinet:
 - 1. Bussmann
 - 2. Circle AW
 - 3. Ferraz-Shawmut
 - 4. Littelfuse
 - 5. Schneider Electric/Square D
 - 6. Or approved equivalent.

2.2 FUSES

- A. Characteristics:
 - 1. Dual element, time delay, current limiting, nonrenewable type, rejection feature.
 - 2. Combination Loads: UL Class RK1, RK5, or J, 1/10 to 600 amp. UL Class L, above 600 amps.
 - 3. Motor Loads: UL Class RK5, 1/10 to 600 amp.
 - 4. Fuse pullers for complete range of fuses.

2.3 MOLDED CASE CIRCUIT BREAKERS

- A. 1-, 2- or 3-pole bolt-on, single handle common trip, 600VAC or 250VAC as indicated on Drawings.
- B. Overcenter toggle-type mechanism, quick-make, quick-break action. Trip indication is by handle position.
- C. Calibrate for operation in 40 degrees C ambient temperature.
- D. 15 to 150 Amp Breakers: Permanent trip unit containing individual thermal and magnetic trip elements in each pole.
- E. 151 to 400 Amp Breakers: Adjustable magnetic trip elements. Provide push-to-trip button on cover of breaker for mechanical tripping.
- F. Greater than 401 Amp: Electronic trip type with adjustments for long-time, instantaneous, and short-time functions.
- G. Circuit breakers 1200 Amp and Greater: Provide breaker with energy-reducing maintenance switching with local status indicator per NEC Article 240.87(B).
- H. Provide ground fault function for breakers greater than 800 amps where applied at 480 volts line-to-line; and where indicated on drawings.

2.4 FUSE CABINET

- A. Enclosure:
 - 1. Metallic cabinet surface mounted, with internal shelves, trim cover with hinged and latched door.
 - 2. Size cabinet such that spare fuses required by these Documents do not exceed 50 percent of cabinet volume.
- B. Label: Provide engraved label to identify as spare fuse cabinet.

PART 3 - EXECUTION

3.1 GENERAL INSTALLATION REQUIREMENTS

- A. Coordination:
 - 1. Obtain and review the submitted product data for equipment furnished by the Owner, and furnished under other Divisions of this contract, particularly under Divisions 22 and 23.
 - 2. Confirm the equipment nameplate maximum overcurrent protection (MOCP) and make accommodations and adjustments to overcurrent protective devices as necessary to coordinate with the nameplate rating.
- B. Install all items in accordance with manufacturers written instructions.

3.2 FUSES

- A. Fuses: For each class and ampere rating of fuse installed, provide the following quantities of spares for quantity of fuses installed:
 - 1. 0 to 24: Provide 6 spare.
 - 2. 25 to 48: Provide 9 spare.
 - 3. 49 and Above: Provide 12 spare.

3.3 MOLDED CASE CIRCUIT BREAKERS

- A. Provide testing of ground fault interrupting breakers.
- B. Provide circuit breakers, as specified and on Drawings, for installation in panelboards, individual enclosures or combination motor starters.
- C. Provide ground fault interrupter circuit breakers for equipment in damp or wet locations.
- D. Provide device on handle to lock breaker in "ON" position for breakers feeding time switches, night lights and similar circuits required to be continuously energized.
- E. Shunt Trip Circuit Breakers: Provide wiring to remote trip switch/contacts as indicated on Drawings.
- F. Provide multi-pole branch circuit breakers for multiwire branch circuits for simultaneous disconnection of circuits.

3.4 FUSE CABINETS

- A. Install fuse cabinet on wall in the Electrical Room in coordination with electrical equipment.

END OF SECTION

SECTION 26 3100 - PHOTOVOLTAIC SYSTEMS

PART 1 - GENERAL

1.1 SUMMARY

- A. Work Included:
 - 1. PV Module and Array
 - 2. Communications

1.2 RELATED SECTIONS

- A. Contents of Division 26, Electrical and Division 01, General Requirements apply to this Section.

1.3 REFERENCES AND STANDARDS

- A. References and Standards as required by Section 26 00 00, Electrical Basic Requirements and Division 01, General Requirements.

1.4 SUBMITTALS

- A. Submittals as required by Section 26 00 00, Electrical Basic Requirements and Division 01, General Requirements.
- B. In addition provide:
 - 1. Overview of major system components and principals of operation.
 - 2. Complete parts lists, including electrical components, mechanical hardware and other equipment required for installing the systems. (Must include description, make, model/part number and source for the equipment provided.)
 - 3. Diagram indicating overall layout of entire system, including PV array, and location of GII and combiner boxes with respect to the array.
 - 4. Electrical schematics and diagrams showing major components and devices, including conductor types and sizes, connections of individual modules and array source circuits, terminations at junction boxes, connection to surge suppression devices and the GII, and the GII interface with the utility grid.
 - 5. Mechanical drawings showing details of module/array mechanical support structure and instructions for assembling and installing arrays on rooftops.
 - 6. Complete assembly and installation instructions for mounting array, junction boxes and enclosures, routing conduit, wiring arrays, and terminating conductors at array, combiner boxes and GII.
 - 7. Procedures for operating, disconnecting, servicing and maintaining complete system and individual components.
 - 8. Warranty information on individual components as required in this bid document.
 - 9. Equipment manufacturer's specifications and operations manuals, including those for PV modules, GII, overcurrent devices, disconnects and optional equipment
 - 10. Qualifications for installer(s), including minimum 5 grid-interactive PV projects of minimum 15 kilowatts at STC within 200 miles of the project site.

1.5 QUALITY ASSURANCE

- A. Quality assurance as required by Section 26 00 00, Electrical Basic Requirements and Division 01, General Requirements.
- B. In addition, meet the following:
 - 1. IEEE Standards Coordinating Committee 21, IEEE 1547 Standard for Interconnecting Distributed Resources with Electrical Power Systems.
 - 2. Underwriters Laboratories, Standard for Safety: Flat-Plate Photovoltaic Modules and Panels, Standard UL 1703.
 - 3. Underwriters Laboratories, Standard for Safety: Inverters, Converters, Controllers and Interconnection System Equipment for Use with Distributed Energy Resources, Standard UL 1741.
 - 4. System designed and installed by a qualified installer with a minimum of 5 years of experience in installation of commercial photovoltaic systems.

1.6 WARRANTY

- A. Warranty of materials and workmanship as required by Section 26 00 00, Electrical Basic Requirements and Division 01, General Requirements.
- B. In addition, provide:
 - 1. Provide minimum 20 year warranty on power output of PV modules.
 - 2. Provide GII with minimum 10 year replacement warranty from the manufacturer covering parts and labor.

PART 2 - PRODUCTS

2.1 MANUFACTURERS

- A. Modules
 - 1. Monocrystalline or Polycrystalline Modules (60-cell):
 - a. SolarWorld (Basis of Design)
 - b. Basis of Design: SunPower
 - c. Canadian Solar
 - d. Trina Solar
 - e. LG
 - f. Or approved equivalent.
- B. Inverters
 - 1. Micro-Inverters
 - a. Enphase Energy (Basis of Design)
 - b. APsystems
 - c. Or approved equivalent.
- C. Combiner/Rapid Shutdown Boxes
 - 1. SolarBOS
 - 2. Yaskawa Solectria RSDCOM
 - 3. Basis of Design: Enphase Combiner Box

4. Or approved equivalent.

D. Power Optimizers

1. Tigo
2. Or approved equivalent.

2.2 PV MODULE AND ARRAY

A. PV Modules: Monocrystalline or Polycrystalline.

B. Non-Thin Film Modules Include: Tempered glass, EVA laminate, weatherproof film. Black, anodized aluminum frames and trim strips. Rated for 1-inch diameter hailstones at 52 mph.

C. Performance requirements:

1. Module Maximum Power (STC): 370 Wp.
2. Minimum Module Efficiency: 22%.
3. Maximum System Voltage: 600 Vdc.
4. Minimum Array Size (STC): 14.8 kW.

D. Physical/mechanical characteristics:

1. Dimensions 61.3-inches by 41.2-inches by 1.8-inches.
2. Weight: _____ pounds.
3. Operating temperature: ____ degrees F to ____ degrees F.

2.3 GRID-INTERACTIVE INVERTER (GII) AND UTILITY INTERCONNECTION

A. Design with GII built specifically for grid-interactive connection photovoltaic arrays to utility, and capable of automatic, continuous, and stable operation over the range of voltages, currents, and power levels for the size and type of arrays used.

B. Provide each GII to be compliant with IEEE 1547 (Standard for Interconnecting Distributed Resources with Electric Power Systems) and meet UL1741 (Inverters, Converters, Controllers and Interconnection System Equipment for Use with Distributed Energy Resources) or equivalent product listing. GII to comply with the latest applicable ANSI and FCC standards and addenda dated prior to the award of the purchase order for this procurement.

C. Provide GII with communications connection for remote monitoring of inverter operation through the internet. Provide and configure software for receiving and tabulating this information through a graphic user interface accessible over the internet. Provide communications card in each GII to allow daisy-chained RS-485 connection between GII's, and interface card for internet communications. Software to provide DC voltage, current, power and energy production, AC voltage, current, power and energy production, operational status of the GII, and graphical record of past production for minimum of 365 previous days on 15 minute increments. Prior to construction, determine location and accessibility to LAN connection point.

D. Provide GII with minimum 10 year replacement warranty from the manufacturer covering parts and labor.

E. Base Bid Inverter _____:

1. GII Performance Criteria:

- a. Maximum Array Input Power: ___ W.
- b. Maximum Input Voltage: ___ Vdc.
- c. Maximum AC Output Current: ___ A at ___ V, 3-phase.

2.4 COMMUNICATIONS

- A. Provide internet portal account through inverter manufacturer to allow real time monitoring of total system and individual inverter power and energy production, with logs going back to at least 365 days.
- B. Portal interface:
 1. In bar graph, show power (watts) and energy (kilowatt-hours) production on hourly basis for one day, daily basis for one month, and daily basis for one year. Provide means to examine past power and energy production for at least the previous 365 days.
 2. Program interface to allow end user to examine power and energy production for the total site, as well as for each individual GII.
 3. Supplemental Display Information: Show PV system size in KW, maximum output production in KW, quantity and manufacturer/model of GII and quantity and manufacturer of PV modules, installation date.
 4. Lifetime Energy Production: Show lifetime total equivalents (e.g. number of typical residences that could be powered for one day, number of cups of coffee that could be brewed with same energy, gallons of gasoline offset, etc.).
 5. Greenhouse Gas Offsets: Show offset quantities for clean energy produced (example: weight of carbon dioxide, nitrogen oxides, sulfur oxides).
 6. Environmental Information: Show current ambient temperature, cell temperature, irradiance, wind speed and direction.
 7. Integration of Other Meters: Show power and energy consumption from sub-metering on main electrical service; see Drawings for locations. Provide and connect to Veris H8163 Series and matching split-core CT.
- C. Basis of Design:
 1. Tie inverters to internet-based data logger via RS-485 connection.
 2. Tie data logger to internet portal via TCP/IP connecting via building local area network. Fronius Interface Card or approved equivalent.
 3. Provide RS-485 and telecommunications cabling and connectivity under Division 27, Communications as required to fulfill Basis of Design.
 4. Provide tele/data outlet in Main Electrical Room where directed by Owner to allow Owner to add flat screen monitor and/or computer for remote monitoring of PV power and energy production through kiosk, remote internet portal site.
 5. Display Package: Provide internet gateway compatible with GII communications, including: Full weather station for display of environmental information specified in this Article, lobby kiosk display software and connectivity as required by Owner, system installer support portal for commissioning system, electrical demand measurement and connection from main electrical sub-meter to internet gateway. Fat Spaniel Insight Views Package, or approved equivalent.

PART 3 - EXECUTION

3.1 SYSTEM DESCRIPTION

- A. These specifications cover the design and procurement of equipment, hardware and documentation required for the installation of grid-connected PV systems.
- B. Provide complete system installation, in addition to documentation on the design, configuration, permit acquisition, installation, operation and maintenance of the complete system and individual components.
- C. System designed for installation in Arlington, VA . Supplied equipment must be rated and warranted to withstand and operate under normal weather conditions at the site.
- D. Each PV system will be connected to the utility electric grid through a grid-interactive power conditioner (inverter). The design and functional specification of the PV modules, power conditioners, utility interconnections, PV system electrical design, and PV array mechanical design are described in the following articles.
- E. Utility Coordination: Coordinate with local Utility Company prior to start of work for location of their net metering equipment, including CT enclosure provided under this Contract per the Drawings, and any additional utility required disconnects which will also be provided under this Contract.
- F. Basis of Design: Provide PV system designed to meet or exceed the performance requirements of the equipment, listed in this specification, while staying under the physical size and weight requirements listed. Costs to allow approved alternative manufacturers and models to meet the performance requirements as specified are part of the scope of this Contract.

3.2 PV SYSTEM ELECTRICAL DESIGN

- A. Provide electrical design and installation instructions for the PV systems conforming to the NEC. Article 690 of the NEC applies specifically to photovoltaic system safety, protection, control and interface with other sources. Other articles of NEC also apply. Comply with IEEE 1547, Standard for Interconnecting Distributed Resources with Electric Power Systems.
- B. Electrical components, including overcurrent protection, disconnects, surge suppression devices, conduit, wiring and terminals must have UL or equivalent listing and have appropriate voltage, current and temperature ratings for the application. Special attention should be given to appropriate ratings for components used in DC circuits.
- C. Wiring must be listed for 600VDC and 600VAC, and a temperature rating of 90C in wet locations. The use of exposed conductors or cabling (excluding grounds) is not acceptable, except MC cable connectors installed under PV modules. Exposed conduit to be painted to match surrounding area. Confirm color with Architect.
- D. Ampacity calculations must take into account appropriate deratings as required. Conductors in the system are subject to a 125 percent NEC derate, and DC source circuit conductors and overcurrent devices must include an additional 125 percent derate for solar radiation enhancements. Appropriate temperature deratings for conductors used in module junction boxes

must be considered for peak module operating temperatures, as well as deratings for instances where more than three current-carrying conductors are enclosed in a conduit.

- E. Voltage drop in array DC source circuits should be limited to no more than 2 percent, including losses in conductors, and through all fuses, blocking diodes and termination points.
- F. Overcurrent devices must have trip ratings no greater than the derated ampacity of the conductors that it protects.
- G. Series connected strings of modules (source circuits) must include a series fuse as required by UL and NEC to prevent excessive reverse current flow through modules in source circuits. Parallel connections of modules in individual source circuits are not permitted. Parallel-connected cells within individual modules are allowable as long as the module listing allows for the series fuse required for this configuration.
- H. Series connected strings of modules (source circuits) must also include a blocking diode to minimize overall array losses due to partial shading of source circuits. These diodes should have low voltage drop to meet the requirements above, and have a voltage and current ratings (at temperature) at least twice the open circuit voltage and short-circuit ratings of the source circuits.
- I. Terminations must use listed box terminal or compression type connections. Twist on wire splices, crimped, soldered or taped connections are not permitted for the required field installed wiring. Proper torque specifications should be provided for the required field connections.
- J. Module frames, metal enclosures, panel boards and the grid-interactive inverter (GII) should be provided with connections for bonding to a common grounding conductor and terminating at the ground electrode system at the utility service entrance point. In addition, provide for grounding the neutral of the GII output. The DC negative circuit may be common to the AC neutral in the GII design and under no circumstances should multiple connections to ground be specified for current carrying conductors in the system.
- K. Provide a weathertight, vented, locking, pad mountable enclosure, suitable for housing the GII, AC/DC disconnect devices, and source circuit combiner boxes (as required). Enclosure rating: NEMA 4, 3R or better and have superior strength and corrosion resistance properties based on the project location.

3.3 PV ARRAY MECHANICAL DESIGN

- A. Provide hardware as required for assembling the photovoltaic modules and panels, and structurally attaching them to the base support structure.
- B. Coordinate PV array and equipment mounting with PV system mounting structures shown on Structural Drawings. Where array and supporting equipment deviate from Basis of Design, include cost of engineering services to update Structural Drawings and Structural Installation for submitted design. Array design that requires modification of building structure in addition to structure supporting PV array and equipment is not acceptable under this Contract.
- C. Provide panel layout design with firefighter access and egress paths per local Codes.

- D. Include a 36-inch wide pathway maintained along three sides of the solar roof. Exceptions to comply with Oregon Solar Installation Specialty Code. For arrays larger than 150-feet, measured in length or width, to have a 36-inch intermediate pathway for service, maintenance and egress. Disconnects, junction boxes, combiner boxes or gutters not to be located in any required pathway or cutout.
- E. Array mounting hardware supplied by the bidder to be compatible with the site considerations and environment. Minimize risk from exposed fasteners, sharp edges, and potential damage to the modules or support structure. Emphasize corrosion resistance and durability of the mechanical hardware. Avoid use of ferrous metals, contact of dissimilar metals or wood or plastic components.
- F. As these are high profile, publicly visible installations, the aesthetics of the overall installation is extremely important to the Owner. To create a uniform appearance of the array, spacing between individual modules and panels should be kept to a minimum. As much as possible, conceal mechanical hardware, conduit, junction boxes and other equipment beneath and/or behind the array.
- G. Be consistent with the ordering and labeling of source circuits in the array combiner boxes. Ease of access for array troubleshooting and maintenance is desired by allowing access to the back of the array for module junction box servicing, and removal/replacement of individual source circuits and modules if necessary.

3.4 INSTALLATION

- A. Grid-Interactive Inverter:
 - 1. Provide fusing for incoming strings.
 - 2. Clean interiors and ensure airways for convective cooling are clear and debris-free.
 - 3. Verify that inverter display measures for AC voltage match measurement from a true-RMS AC digital voltmeter.
 - 4. Check that maximum power point tracking circuit is operational. Monitor array voltage from open circuit condition until it reaches a point where system power peaks and then starts to drop again. Provide chart of field measurements input and output voltage and current through the day as part of O&M manual.
 - 5. Provide factory required clearances and air space for cooling and ventilation.
- B. Photovoltaic System Wiring:
 - 1. Field connections: Use crimp-on connectors that maintain connection even when screw loosens.
 - 2. Size wiring from inverter to PV modules based on less than 2 percent voltage drop in any string.
 - 3. Conceal flexible conduit and MC cable to underneath the PV modules. Outside of the PV modules, use rooftop conduit per Division 26, Electrical.
 - 4. PV module wiring to be secured to run parallel and perpendicular to module frame lines, as well as be secured to module and module support structure. Do not allow PV module wiring to rest unsupported against the roof surface.
 - 5. Provide strain reliefs and cable clamps on cable and cords for PV modules.
 - 6. Retorque terminations prior to completion of construction.

- C. Grounding:
1. Verify that one connection to DC circuits and one connection to AC circuits is being used for system grounding referenced to the same point. Bond to buildings main grounding system.
 2. Provide bonding for non-current carrying metal parts to ensure they are grounded properly.
 3. Grounding electrode to be installed in accordance with NEC Article 250.122 (AC) but not smaller than #6 AWG copper or #4 AWG Aluminum.
 4. Provide grounding electrodes at the location of ground and pole mounted arrays as close as possible. Bond to buildings main grounding system.
- D. Signage:
1. Post an "Interactive Point of Connection" sign per NEC Article 690.
 2. Place a sign at building service entrance indicating type and location of on-site interactive electric power production sources and disconnects per NEC Article 705.
 3. At each inverter, post a sign indicating:
 - a. Label for Inverter.
 - b. Operating current and voltage.
 - c. Maximum system voltage.
 - d. Short circuit current.
- E. Install PV panels, inverter, wiring, protection device as per written installation instructions from the manufacturer.
- F. Coordinate mounting of panels with structural engineer and roof system installer prior to submitting design documents.

3.5 TESTING

- A. Test each PV panel per manufacturer's written instructions prior to connection to inverter. String level testing is allowed. Document test results and submit in O&M manuals.
- B. Test inverters per manufacturer's written instructions. Document test results and submit results with O&M manuals.

3.6 DISPLAY COMMISSIONING AND TRAINING

- A. Coordinate with Owner for TCP/IP address for PV communications gateway prior to start of programming.
- B. Provide manufacturer supported programming and commissioning services as required for functionality of system as described above. Provide Owner minimum two 2-hour training sessions on separate days with factory support, for use of both internet portal and review installation of communications system. Provide audio/video record of both sessions. Hold either session no less than 30 days from date of substantial completion of the project.

END OF SECTION

SECTION 26 3214 - GAS FIRED ENGINE GENERATORS

PART 1 - GENERAL

1.1 SUMMARY

A. Work Included:

1. Packaged Engine Generator System
2. Engine
3. Fuel System
4. Lubrication
5. Inlet Air System
6. Exhaust System
7. Cooling System
8. Heaters
9. Engine Speed Governing System
10. Batteries and Charger System
11. Automatic Starting System
12. Generator
13. Generator Control Panel
14. Generator Remote Annunciation Panel
15. Accessories

B. System Description:

1. Engine generator set, in conjunction with the necessary control and accessories, will comprise complete operating package for KW ratings as shown on Drawings for installation at local elevation and ambient temperature extremes (average maximum and average minimum) as recorded by local U.S. Weather Bureau meteorological station.
2. Provide engine generator set and transfer switches compliant with Level 1 Emergency Power Supply System (EPSS) under NFPA 110.
3. Provisions and connection of automatic transfer switches to comply with NFPA-70 requirements and requirements of Section 26 3600, Transfer Switches. Include control wiring with transfer switch for automatic start/stop control to generator control panel equipment.
4. Provide connection to natural gas. Gas cock, strainer pressure regulator system as shown on Division 23, HVAC Drawings. Piping, fittings and connections for natural gas fuel delivery are executed in accordance with Division 23, HVAC Specifications. This Contract supplies cascaded fuel solenoid valves and local stop cock valve.
5. Provide propane backup, unless otherwise noted, including storage, pumps, sensors, piping, venting and other associated equipment.
6. Provide as part of generator assembly, pressure switches, solenoid valves, and engine timing as required to change automatically from natural gas to propane source, and vice versa, based on adequate line pressure of natural gas source.
7. Provide exhaust system in compliance with current federal EPA tier for exhaust emissions, and any state and local environmental air quality standards.

1.2 RELATED SECTIONS

- A. Contents of Division 26, Electrical and Division 01, General Requirements apply to this Section.

- B. In addition, reference the following:
 - 1. Section 26 05 73, Electrical Distribution System Studies.
 - 2. Section 26 28 00, Overcurrent Protective Devices.

1.3 REFERENCES AND STANDARDS

- A. References and Standards as required by Section 26 00 00, Electrical Basic Requirements and Division 01, General Requirements.
- B. In addition, meet the following:
 - 1. Conform to requirements of the following generator set installation and on-site testing to codes and standards, as applicable. Include necessary features to meet requirements of these standards.
 - a. IEEE 446, Recommended Practice for Emergency and Standby Power Systems for Commercial and Industrial Applications.
 - b. NFPA 37, Standard for Installation and Use of Stationary Combustion Engines and Gas Turbines.
 - c. NFPA 70, National Electrical Code. Equipment suitable for use in systems compliant to Articles 700, 701, and 702.
 - d. NFPA 110, Standard for Emergency and Standby Power Systems. Generator set will meet requirements for Level 1 systems. Level 1 prototype tests required by this standard will have been performed on a complete and functional unit, component level type tests will not substitute for this requirement.
 - 2. Generator set and supplied accessories to meet the requirements of the following standards:
 - a. NEMA MG1. Alternator to comply with requirements of this standard.
 - b. UL 142, Steel Aboveground Tanks for Flammable and Combustible Liquids.
 - c. UL 1236, Battery Chargers for Charging Engine-Starter Batteries.
 - d. UL 2200, Stationary Engine Generator Assemblies. List generator set to UL 2200 or submit to an independent third party certification process to verify compliance as installed.
 - 3. Comply with the following control system requirements:
 - a. EN50082-2, Electromagnetic Compatibility - Generic Immunity Requirements, Part 2: Industrial.
 - b. EN55011, Limits and Methods of Measurement of Radio Interference Characteristics of Industrial, Scientific and Medical Equipment.
 - c. FCC Part 15, Subpart B.
 - d. UL 508, Industrial Control Equipment. Entire control system of generator set UL 508 listed and labeled.
 - e. UL 1236, Battery Chargers for Charging Engine-Starter Batteries.

1.4 SUBMITTALS

- A. Submittals as required by Section 26 00 00, Electrical Basic Requirements and Division 01, General Requirements.
- B. In addition, provide:
 - 1. Shop Drawings: Indicate electrical characteristics and connection requirements. Show plan and elevation views with overall and interconnection point dimensions, fuel

- consumption rate curves at various loads, ventilation and combustion air requirements, electrical diagrams including schematic and interconnection diagrams.
2. Product Data: Provide data showing dimensions, weights, ratings, interconnection points, and internal wiring diagrams for engine, generator, control panel, battery, battery rack, battery charger, exhaust silencer, vibration isolators, remote alarm annunciators, auxiliary equipment. Technical literature describing natural gas engine generator set performance including certified engine horsepower curves and deratings for project site altitude and ambient temperature conditions.
 3. Test Reports: Indicate results of factory testing showing minimum 1-hour test with 1/2-hour at continuous 100 percent load at 0.8 power factor. Record voltage stability, frequency stability, and transient response at 1/4, 1/2, full load, and 90 percent single step.
 4. Manufacturer's Installation Instructions: Indicate application conditions and limitations of use stipulated by product testing agency. Include instructions for storage, handling, protection, examination, preparation, installation, and starting of product.
 5. Manufacturer's Certificate: Certify that products meet or exceed specified requirements.
 6. Manufacturer Seismic Qualification Certification:
 - a. Submit certification that engine-generator set, batteries, battery racks, accessories, and components will withstand seismic forces defined in ASCE 7-10, Chapter 13, Seismic Design Requirements for Nonstructural Components. Include the following:
 - 1) Basis of Certification: Indicate whether withstand certification is based on actual test of assembled components or on calculation.
 - 2) Term "withstand" means "the unit will remain in place without separation of any parts from device when subjected to seismic forces specified and unit will be fully operational after seismic event."
 - 3) Dimensioned Outline Drawings of Equipment Unit: Identify center of gravity and locate and describe mounting and anchorage provisions.
 - 4) Detailed description of equipment anchorage devices on which certification is based on their installation requirements.
 7. Manufacturer's Field Reports: Indicate procedures and findings.
 8. Operation Data: Include instructions for normal operation, with description and illustration of engine and generator controls and indicators.
 9. Maintenance Data: Include instructions for routine maintenance and testing requirements, service manuals for engine, analysis for engine wear, and emergency maintenance procedures.
 10. Maintenance Agreement: Provide optional authorized dealer service contract to perform routine maintenance and service for a period of 5 years to Owner for comment and/or approval.
 11. Maintenance Materials: Furnish the following for Owner's use in maintenance of engine generator.
 - a. Extra Filter Elements: One of each type, including fuel, oil and air.
 - b. Parts books which illustrate and list assemblies, subassemblies and components, except standard fastening hardware (nuts, bolts and washers).
 - c. Preventative maintenance instructions on complete system that cover daily, weekly, monthly, biannual, and annual maintenance requirements and include complete lubrication chart.
 - d. Routine Test Procedures for electronic and electrical circuits and for main AC generator.

- e. Troubleshooting Chart covering complete generator set showing description of trouble, probable cause and suggested remedy.
 - f. Recommended Spare Parts List showing consumables required during routine maintenance and testing.
12. Completed emergency generator and automatic transfer switch training checklist.

1.5 QUALITY ASSURANCE

- A. Quality assurance as required by Section 26 00 00, Electrical Basic Requirements and Division 01, General Requirements.
- B. In addition, meet the following:
 1. Manufacturer Qualifications: Company specializing in manufacturing products specified in this Section with minimum ten years documented experience with a local supplier and service organization.
 2. Supplier Qualifications: Authorized distributor of specified manufacturer with minimum five years documented experience. Generator supplier is responsible for engine, generator, automatic transfer switches, battery charger, engine block heater, automatic start/stop control equipment and circuitry, and seismic bracing, so that there is one source of supply and responsibility. Authorized distributor must have 24-hour service facilities within 25 miles of Project and maintain qualified, factory trained service personnel that can respond to an emergency call within 4 hours notification.

1.6 WARRANTY

- A. Warranty of materials and workmanship as required by Section 26 00 00, Electrical Basic Requirements and Division 01, General Requirements.

PART 2 - PRODUCTS

2.1 MANUFACTURERS

- A. Packaged Engine Generator:
 1. Caterpillar
 2. Cummins
 3. Kohler
 4. Generac
 5. MTU Onsite Energy
 6. Or approved equivalent.
- B. Approved manufacturers listed are allowed on condition of meeting specified conditions including available space for equipment (including Code required working clearances). Remove and replace electrical equipment installed not meeting these conditions at no cost to Owner.

2.2 PACKAGED ENGINE GENERATOR SYSTEM

- A. Generator set to meet requirements for Level 1, Type 10 systems as per NFPA 110. System to be capable of providing power within 10 seconds following loss or failure of normal power supply and accept full load at each level of priority in single step.

- B. Voltage and load rating of generator set is as indicated on drawings. Load rating to be for standby service at 0.8 power factor and derated to allow for operation of accessories (cooling fan, pumps, radiator, fan, air cleaners, lubricating oil pump, fuel injection pump, jacket water pump, governor, charging generator, alternating current generator, exciter regulator and alternator) and for service at an altitude of ___-feet, in ___ degrees F to _____ ambient temperature.
- C. Unit Mounting:
 - 1. Provide engine and generator equipped with common steel weldment/sub-base for mounting engine generator unit to concrete slab or foundation.
 - 2. Unit to be mounted on structural steel base and be provided with pad type vibration isolators and seismic restraints as required. Restraints/isolators to be in accordance with seismic design category and importance factor as indicated on structural documents, and to be adjusted per manufacturer's recommendations at start-up.
 - 3. Isolators (Pad Type): Resistant to heat and age, impervious to oil, water antifreeze, and cleaning compounds.

2.3 ENGINE

- A. Natural gas driven, spark ignition engine, liquid cooled producing 1.5 HP per KW to operate at 1800 rpm for full electrical output rating. Engine to be mounted to continuous structural steel frame under complete unit.
- B. Emissions: Comply with current Federal EPA Tier for Exhaust Emissions and possess Best Available Current Technology to provide absolute minimum smoke, fumes, and exhaust emissions discharge.
- C. Engine Speed: 1800 rpm.
- D. Safety Devices: Engine shutdown on high engine temperature, low oil pressure, overspeed, and engine overcrank. Limits as selected by manufacturer.
- E. Engine Starting: DC starting system with positive engagement, number and voltage of starter motors in accordance with manufacturer's instructions. Include remote starting control circuit, with MANUAL-OFF-REMOTE selector switch on engine-generator control panel.
- F. Engine Jacket Heater: Thermal circulation type water heater with integral thermostatic control, sized to maintain engine jacket water at 90 degrees F.
- G. Engine Accessories: Fuel filter, lube oil filter, intake air filter, lube oil cooler, gear-driven water pump. Include water temperature gauge, and lube oil pressure gauge on engine/generator control panel.

2.4 FUEL SYSTEM

- A. Provide the engine with a complete fuel system consisting of two cascaded 12VDC valves, manual gas cock valve, carburetor, fuel strainer, flexible piping and associated piping. Pressure regulator setting and fuel flow criteria is to be coordinated with Division 23, HVAC prior to installation of gas lines.

- B. Provide fully automatic dual fuel system natural gas/propane vapor.
- C. Provide flexible fuel supply lines.
- D. Provide a fuel pressure switch on supply side of cascaded solenoid valves. Connect switch as a low fuel supply alarm on pressure drop below minimum supply criteria for engine.
- E. Connect solenoid valves so valves are closed (no fuel flow) when solenoids are deenergized.
 - 1. Solenoids are energized (fuel flows) when engine start is signaled (both automatically and manually).
 - 2. Solenoids are deenergized when:
 - a. Engine stop is signaled (both automatically and manually).
 - b. Engine is stopped on wait periods of overcrank protection.
- F. The engines meet the requirements specified herein when operating on natural gas fuel.

2.5 LUBRICATION

- A. Meet requirements as specified using lubricating oil conforming to MIL-L-2104, viscosity grade as recommended by engine manufacturer.
- B. Provide engine with gear-type lubricating oil pump for supplying oil under pressure to main bearings, pistons, piston points, timing gears, camshaft bearings and valve rocker mechanism.
- C. Provide full flow oil filters, conveniently located for servicing. Equip filter with spring loaded bypass valve to ensure oil circulation if filters are clogged. Provide suitable oil cooler as recommended by engine manufacturer.
- D. Provide an oil drain line extension with manual shutoff valve as part of engine oil pan.

2.6 INLET AIR SYSTEM

- A. Engine air cleaner to be engine mounted with dry element and restriction indicator to visually indicate to facility staff the need for filter replacement.

2.7 EXHAUST SYSTEM

- A. Engine manufacturer to ensure generator set will meet all applicable exhaust emission requirements at time of start-up.
- B. Critical grade silencer, companion flanges, and flexible stainless steel exhaust fitting properly sized to be furnished by generator manufacturer. Silencer to be mounted so that its weight is not supported by engine nor will exhaust system growth due to thermal expansion be imposed on engine. Exhaust pipe size to be sufficient to ensure that exhaust back pressure does not exceed maximum limitations specified by engine manufacturer.

2.8 COOLING SYSTEM

- A. Equip generator set with rail-mounted, engine-driven radiator with blower type fan and accessories. Size cooling system to maintain safe engine temperature at full load conditions in

an ambient temperature of 104 degrees F (40 degrees C) without de-rating unit and 50/50 anti-freeze mixture. Fill radiator with an extended life coolant with minimum estimated life of 6,000 hours or 6 years. Coolant formula to contain no phosphates or silicates, and be recyclable. Generator set supplier is responsible for providing properly sized cooling system.

- B. Engine jacket water cooling system to be closed circuit design with provision for filling, expansion, and deaeration, rated for 104 degrees F (40 degrees C) ambient at project elevation. Equip engine with an engine driven, centrifugal-type water circulating pump and thermostatic valve to maintain engine at manufacturers recommended temperature level. Coolant temperature to be internally regulated to disconnect external cooling systems until operating temperature is achieved.

2.9 HEATERS

- A. Engine jacket heater: Heated by unit mounted auxiliary electric liquid heater, sized as recommended by the engine manufacturer to ensure a minimum coolant temperature of 120 degrees F in an ambient temperature of 20 degrees F.
- B. Provide engine jacket heater with an automatic control thermostat and oil pressure disconnect switch.
- C. Incorporate manual shutoff valves to isolate heater during servicing.

2.10 ENGINE SPEED GOVERNING SYSTEM

- A. Governor to control engine speed while optimizing both steady state and transient engine performance and provide automatic frequency regulation. Control will monitor significant engine parameters, and adjust engine performance according to speed, altitude, temperature, aftercooler temperature, and engine condition. Incorporate revisable control software capable of reconfiguring engine operation to desired performance levels.

2.11 BATTERIES AND CHARGER SYSTEM

- A. Provide heavy-duty lead-acid batteries having sufficient capacity for cranking engine for at least 90 seconds at firing speed in ambient temperatures specified in these Specifications and with capacity for starting natural gas engine a minimum of four times.
- B. Provide batteries complete with intercell connections and mounted in metal tray of corrosion resisting metal conforming to NEC 480.8. Construct tray such that spillage or boil-over battery electrolyte will be contained within tray to prevent direct path to ground.
- C. Provide battery charger enclosed (weatherproof if exterior), wall mounted, constant voltage, heavy duty, industrial type designed for operation from 120 volt, 1 phase, 60 Hz, AC power. Charger suitable for keeping engine starting batteries in charged condition during periods when engine is idle. Rectifier Elements: Silicon diodes capable of continuous operation at full rated load using convection cooling in ambient temperatures up to 125 degrees F. Charger automatically adjusts from full rated output to trickle charge and from trickle charge to full rated output, depending on state of charge of battery. Provide charger equipped with DC voltmeter, DC ammeter, AC and DC circuit protection, voltage surge suppression. Charger to have LED annunciator for low dc volts, rectifier failure, loss of ac power, and high dc volts.

2.12 AUTOMATIC STARTING SYSTEM

- A. Engine Starting System: 24 volt DC, including dual starting motors, starter relay, and automatic reset circuit breaker to protect against butt engagement.

2.13 GENERATOR

A. Rating:

1. Generator to be capable of producing rated voltage and output at 0.8 power factor, based upon site conditions of altitude and ambient temperatures.
2. Provide generator rating applicable for continuous service in standby power application. Maximum voltage dip on full load and power factor is 25 percent.
3. Temperature Rise: 80 degrees C above 40 degrees C ambient.
4. The generator stator windings are heated via a direct current flow in two of the 3 phase winding sets while the generator is off. An Allen Bradley Model 1410 motor winding heater is installed on the generator stator windings. Control relays and contactors are provided to disconnect the heating current when the fuel solenoids are energized and to display reconnecting the heating current for 15 minutes after fuel solenoid deenergization.

B. Construction:

1. Provide generator with revolving field, single bearing type, coupled directly to engine flywheel through a flexible driving disc for positive alignment. Provide rotor dynamically balanced up to 25 percent overspeed.
2. Provide generator of heavy duty, compact design. Insulation is Class H or better on stator and rotor, as recognized by NEMA MG-1 and both to be further protected with 100 percent epoxy coating to reduce possible fungus and/or abrasion deterioration.
3. Permanent magnet or AREP excitation system to derive excitation current from pilot exciter mounted on rotor shaft. System to enable alternator to sustain 300 percent of rated current for ten seconds during fault condition.
4. Digital Voltage Regulator: Microprocessor based with fully programmable operating and protection characteristics. Regulator capable of sensing true RMS in three phases of alternator output voltage, or operating in single phase sensing mode. Exhibit the following operational characteristics:
 - a. Voltage regulation from no load to rated load within plus or minus 0.25 percent of rated voltage.
 - b. Steady state voltage stability within plus or minus 0.25 percent of rated voltage.
 - c. Alternator output voltage drift no more than plus or minus 0.25 percent of rated value at constant temperature.
 - d. Alternator output voltage drift no more than plus or minus percent of rated value within 40 degrees C change over ambient temperature range of -40 degrees C to 70 degrees C.
 - e. Steady state voltage modulation not to exceed 1 cycle per second.
 - f. Voltage buildup with alternator output as low as 6 volts.
 - g. At full throttle engine starting, output voltage overshoot no more than 5 percent of its rated value, with respect to volts/Hz curve. Meet ISO 8325-3 class G2 specifications.
 - h. Telephone Influence Factor (TIF) of less than 50.

- i. Electronic Interference/Radio Frequency Interference (EMI/RFI) suppressed to MIL STD 461C Part 9 and VDE 875 level N.
5. Voltage regulator to include the following features:
 - a. Voltage Level Rheostat: Provide alternator output voltage adjustment of minus 10 percent to plus 10 percent of nominal, in addition to programmable output voltage level of minus 25 percent to plus 10 percent.
 - b. Automatic Gain Adjustment: Provide output voltage compensation for changes in load or frequency.
 - c. Manual Gain Adjustment: 0 to 10 percent to provide compensation for line losses between alternator output terminals and load.

C. Generator Set Performance:

1. For addition of load up to and including 100 percent of rated load, voltage dip not to exceed 15 percent of rated voltage. Voltage to recover to and maintain within steady band in not more than 1.5 seconds.
2. Frequency Regulation: Steady state no load to steady state rated load. Random frequency variation with any steady load not to exceed plus or minus 0.5 percent. For addition of load up to 90 percent of rated load, frequency to recover to steady state frequency band within 5 seconds.

2.14 GENERATOR CONTROL PANEL

- A. Generator Set Control: Provide generator set with microprocessor-based control system that is designed to provide automatic starting, monitoring, and control functions for generator set. Design control system also to allow local monitoring and control of generator set, and remote monitoring and control as described in this specification.
- B. Generator set mounted control to include the following features and functions:
 1. Control Switches:
 - a. Mode Select Switch: Mode select switch to initiate the following control modes. When in RUN or MANUAL position generator set starts, and accelerate to rated speed and voltage as directed by operator. Separate push-button to initiate starting is acceptable. In OFF position generator set to immediately stop, bypassing time delays. In AUTO position generator set to be ready to accept signal from remote device to start and accelerate to rated speed and voltage.
 - b. EMERGENCY STOP Switch: Red "mushroom-head" pushbutton. Depressing emergency stop switch to cause generator set to immediately shut down, and be locked out from automatic restarting.
 - c. RESET Switch: Switch to clear fault and allow restarting generator set after it has shut down for any fault condition.
 - d. PANEL LAMP Test Switch: Depressing panel lamp switch to cause entire panel to be lighted.
- C. Generator Set AC Output Metering: Provide generator set with metering set including the following features and functions:
 1. Digital Metering Set: Indicate generator RMS voltage and current, frequency, output current, output KW, KW-hours, and power factor within 1 percent accuracy at rated output. Generator output voltage to be available in line-to-line and line-to-neutral voltages, and display 3-phase voltages (line to neutral or line to line) simultaneously.

- D. Generator Set Alarm and Status Display:
1. Generator Set Control: Include LED alarm and status indication lamps. Lamps to be high-intensity LED type. Lamp condition clearly apparent under bright room lighting conditions. Indicate existence of warning and shutdown conditions on control panel and comply with protection and diagnostic requirements of NFPA 110 for a Level 1 EPSS. Conditions indicated below for warning to be field-configurable for shutdown. Conditions required to be annunciated include:
 - a. Control Switch Not in Auto (Warning)
 - b. Emergency Stop Depressed (Warning)
 - c. Battery Charger AC Failure (Warning)
 - d. Low Oil Pressure (Warning)
 - e. Low Oil Pressure (Shutdown)
 - f. Low Coolant Temperature (Warning)
 - g. High Coolant Temperature (Warning)
 - h. High Coolant Temperature (Shutdown)
 - i. High Oil Temperature (Warning)
 - j. Low Coolant Level (Warning)
 - k. Fail to Start/Overcrank (Shutdown)
 - l. Overspeed (Shutdown)
 - m. Low DC Voltage (Warning)
 - n. High DC Voltage (Warning)
 - o. Low Fuel Level (Warning)
 - p. High AC Voltage (Shutdown)
 - q. Low AC Voltage (Shutdown)
 - r. Under Frequency (Shutdown)
 - s. Overcurrent (Warning)
 - t. Overcurrent (Shutdown)
 - u. Short Circuit (Shutdown)
 - v. Generator Powering Load
- E. Engine Status Monitoring: The following information to be available at digital status panel on generator set control:
1. Engine Oil Pressure (PSI or kPa)
 2. Engine Coolant Temperature (degrees F or C)
 3. Engine Oil Temperature (degrees F or C)
 4. Engine Speed (rpm)
 5. Engine Running Time Meter
 6. Battery Voltage (DC Volts)
- F. Engine Control Functions:
1. Include cycle cranking system, which allows for user selected crank time, rest time, and number of cycles. Initial Settings: 3 cranking periods of 15 seconds each, with 15-second rest period between cranking periods.
 2. Include an idle mode control, which allows engine to run in idle mode in RUN position only. In this mode, alternator excitation system disabled.
 3. Include an engine governor control, which functions to provide steady state frequency regulation as noted elsewhere in this specification. Governor control to include

adjustments for gain, damping, and a ramping function to control engine speed and limit exhaust smoke while unit is starting.

2.15 GENERATOR REMOTE ANNUNCIATION PANEL

- A. Provide LED type remote alarm annunciator with horn. Provide audible and visual alarms called for by NFPA Standard 110 for Level 1 systems for local generator control panel. Provide spare lamps to allow future addition of other alarm and status functions to annunciator. Make provisions for labeling of annunciator in fashion consistent with specified functions. Provide alarm silence and lamp test switch(es). LED lamps to be replaceable, and indicating lamp color capable of changes needed for specific application requirements. Alarm horn to be switchable for annunciation points. Alarm horn (when switched on) to sound for first fault, and subsequent faults, regardless of whether first fault has been cleared, in compliance with NFPA 110. Interconnecting wiring between annunciator and other system components to be monitored and failure of interconnection between components to be displayed on annunciator panel.
- B. Annunciator to include the following alarm labels, audible annunciation features, and lamp colors:

Condition	Lamp Color	Audible Alarm
Genset Supplying Load	Amber	No
Not in Auto	Red	Yes
High Battery Voltage	Red	Yes
Low Battery Voltage	Red	Yes
Charger AC Failure	Red	Yes
Fail to Start/Overcrank	Red	Yes
Low Engine Temperature	Amber	Yes
Pre-High Engine Temperature	Amber	Yes
High Engine Temperature	Red	Yes
Pre-Low Oil Pressure	Amber	Yes
Low Oil Pressure	Red	Yes
Overspeed	Red	Yes
Low Coolant Level	Amber	Yes
Low Fuel Level	Amber	Yes
Genset Shutdown	Red	Yes
(4) Spares	Configurable	Configurable

- C. Low battery voltage lamps to also be lighted for low cranking voltage or weak battery alarm.
- D. Provide surface mounted enclosure.

2.16 ACCESSORIES

- A. Unit Mounted Circuit Breaker:
 - 1. Provide generator set with mounted main line circuit breaker, sized to carry rated output current of generator set and comply with selective coordination per Section 26 0573, Electrical Distribution System Studies.

2. Circuit breaker to incorporate an electronic trip unit that operates to protect alternator under overcurrent conditions, or thermal-magnetic trip with other overcurrent protection devices that positively protect alternator under overcurrent conditions. Supplier to submit time overcurrent characteristic curves and thermal damage for alternator, demonstrating effectiveness of protection provided. Provide auxiliary contact to report to remote annunciator panel in event of an open breaker condition.
3. Circuit breaker to be provided by the same manufacturer as Section 26 24 13, Switchboards.
4. Provide circuit breaker equipped with bus stub connections for compression fittings by Contractor.
5. Remote annunciator panel to monitor breaker and report trouble signal when open.

PART 3 - PRODUCTS

3.1 GENERAL INSTALLATION REQUIREMENTS

- A. Concrete Pad: Provide concrete pad of 2500 to 3000 PSI concrete reinforced with 8 gauge wire fabric or No. 6 reinforcing bars on 12-inch centers. Provide 10-inch thick base of gravel below pad for support. Extend pad 6-inches on all sides from the exterior unit dimensions. Provide 8-inch thick pad.
- B. Verify piping requirements for natural gas and propane to engine.
- C. Reference Section 26 05 26, Grounding and Bonding for Electrical Systems, for grounding requirements.
- D. Install in accordance with manufacturer's instructions.
- E. Install securely and in neat and workmanlike manner.
- F. Provide all wiring required for a complete and operable system.
- G. Provide branch circuits and power and control connections for accessories.
- H. Install signaling and control circuiting as required for remote annunciation, battery charger alarm, automatic start-stop of generator set, etc.
- I. Provide arc flash labels per Section 26 05 73, Electrical Distribution System Studies.
- J. Provide services of manufacturer's representative to prepare and start system.
- K. Perform field inspection and testing in accordance with these specifications.

3.2 PACKAGED ENGINE GENERATOR SYSTEM

- A. Coordinate mounting requirements with generator concrete slab pour (or mounting foundation) to eliminate vibration movement, per manufacturer's specifications.

3.3 HEATERS

- A. Prior to running circuits and ordering branch circuit breakers, contractor to confirm that block heater electrical characteristics match branch circuits shown.

3.4 ENGINE SPEED GOVERNING SYSTEM

- A. Configure engine control to avoid interruption of power whenever possible. In event of system faults which do not require immediate shutdown, program engine to continue operation at power levels sufficient to remain within performance limits. Display real time and historical data to allow user to optimize operation and provide accurate service information in event of malfunction. Information to be accessible through data link for remote monitoring. Data link failure is not to cause an interruption of engine operation. Governing system to include programmable warm-up at idle and cool down at idle function. While operating in idle state, control system to disable alternator excitation system.

3.5 BATTERIES AND CHARGER SYSTEM

- A. Prior to running circuits and ordering branch circuit breakers, contractor to confirm that battery charger electrical characteristics match branch circuits shown.

3.6 AUTOMATIC STARTING SYSTEM

- A. Provide wiring within transfer switches in accordance to NFPA-76A and NEC requirements.
- B. Install and connect automatic transfer switch components of essential electrical system so that within 10 seconds of power supply drop in Utility Company's normal service, generator starts and automatically transfer loads to generator source.

3.7 GENERATOR CONTROL PANEL

- A. Mount control on generator set, or may be mounted in free-standing panel next to generator set if adequate space and accessibility is available. Control will be vibration isolated and prototype tested to verify durability of components in system under vibration conditions encountered.

3.8 GENERATOR REMOTE ANNUNCIATION PANEL

- A. Install at location shown on drawings or in location that can be conveniently monitored by facility personnel.

3.9 TESTING

- A. Reference Section 26 08 05, Electrical Acceptance Testing.
- B. Before equipment is installed, submit to Architect factory certified test log of generator set, showing minimum one hour test with generator run continuously at full load at 0.8 power factor. Provide normal preliminary engine and generator tests before unit assembly.
- C. Upon installation completion and prior to acceptance of installation, perform following tests by system manufacturer's local dealer representative(s) in presence of Architect, Authority Having

Jurisdiction (AHJ), as well as Owner's engineer or designated appointee from each. Each individual generator will be tested:

1. Pre-Start Checks.
 2. Cycle Crank Test (per manufacturer's recommendations).
 3. Fuel Tank Level.
 4. Oil Level.
 5. Engine Generator Intake Obstructions.
 6. Engine Generator Exhaust Obstructions.
 7. Water Level.
 8. Batteries Connection and Charge Condition.
 9. Air Start Supply Pressure (if so equipped).
 10. Transfer Switch Settings (in compliance with NFPA 110 and Owner direction).
 11. Engine to Control Interconnects.
 12. Engine Room Ventilation Obstructions.
 13. Removal of Packing Materials.
 14. Load Bank Testing: Provide load bank with sufficient capacity to operate single generator at full load. Do not use building loads for these tests.
 - a. Full Load Bank Test: Run each generator for minimum of 2 hours at 100 percent of nameplate rating of the generator. Record the following system characteristics: Cranking time, time to operating speed, voltage overshoot, frequency overshoot, time to steady-state, voltage, frequency, amps, oil pressure, engine coolant temperature, and battery charge rate.
 - b. One Step Full Load Test: Upon completion of the above 2-hour test, turn off load bank. Turn load bank on again as single step and record voltage and frequency stability with power line analyzer to show how generator reacted during first 10 seconds following addition of load.
 - c. 50 Percent Load Step Test: Reduce load bank by approximately 40 to 60 percent as single step, and then re-add the load. Record voltage and frequency stability at each step with power line analyzer.
 - d. Full Building Load Test: Open all breakers supplying primary power to site and allow emergency power system to run for minimum of 2 hours. Record the following system characteristics: time delay on start, cranking time, time to operating speed, voltage overshoot, frequency overshoot, time to steady-state with switches transferred to emergency position, voltage, frequency, amps, oil pressure, engine coolant temperature, battery charge rate, and time delay on retransfer to normal power. Comply with installation acceptance requirements for Level 1 Emergency Power Supply System (EPSS) under Chapter 7, NFPA 110.
 - 1) Test individual generator safety switches.
 15. After all testing is complete, top off the propane fuel tank to its full capacity before turning over to the Owner.
- D. Provide separate maintenance contract for specified maintenance service.
- E. Provide service and maintenance of engine generator for one year from Date of Substantial Completion
- F. Engine generator set supplier is to be an authorized dealer of engine generator set manufacturer and fully qualified and authorized to provide service and parts for both engine generator and such auxiliary equipment as may be required.

- G. Provide manufacturer's warranty of a 2-year term, based on date of occupancy of facility.
- H. Training to be provided by manufacturer's technical representative to instruct Owner's personnel in operation and maintenance of equipment provided. Completed emergency generator Owner's training checklist to be submitted with final shop drawings and O&M manuals. Checklist at end of this Section is to be used as an alternate if no formal training checklist is provided by manufacturer's technical representative. Note that some sections like paralleling switchgear, bypass isolation transfer switches and load shedding may not apply to this project.
- I. EMERGENCY GENERATOR/OWNER'S TRAINING CHECKLIST

Item	Description
1	Identify equipment model, serial numbers, and location of identifying markings on the physical equipment.
2	Review system interface with other systems including fire alarm, elevator controllers, automatic transfer switches, HVAC, UPS systems, etc.
3	Describe product warranty requirements: Who to contact and contact numbers. Indicate owner obligations for warranty satisfaction and ongoing service.
4	Demonstrate system operation and describe design intent of system.
5	Describe system operation which would include, but not be limited to, checking propane fuel levels, systems functions, alarms, adjusting system setpoints, and general maintenance procedures.
6	Describe system fluid capacities for fuel/lube/coolant, change intervals and procedures for checking, draining, refilling fluids.
7	Describe remote annunciator features, alarm points reset procedures status and how to interpret the display.
8	Describe control panel features, alarms, troubleshooting, status, and how to interpret the display.
9	Review ATS location, quantity, logic controllers, shutdown functions, and interface with genset. For bypass isolations Type ATS's, demonstrate actual bypass isolation functional procedure.
10	Explain purpose and proper setting of the various timers in the automatic transfer switches.
11	Describe complete operation of load shedding system.
12	Explain full operation of the paralleling board controls including manual paralleling during emergencies.
13	Describe proper operation of the propane tank(s).
14	For paralleling switchgear, specifically go through operating principals of manual operation procedures including manual paralleling, load controls, generator priority, logic/automation, and event logging.
15	Specifically go through cooling system operating principals and maintenance, including airflow, engine jacket heaters, and associated hoses.
16	Specifically go through operating principals and maintenance of starting system, batteries, and chargers.
17	Specifically go through fuel system, including filters.
18	Describe troubleshooting, programming, and manual operation procedures.
19	Review safety and emergency shutdown procedures as applicable.

20	Describe product maintainability, spare parts provided, and resources for parts support.
21	Describe the use of O & M manuals and provide input on best practices.

Trainer	Company	Total Req'd Hours	Hours Trained	Date

J. TRAINING ATTENDEES:

Name/Role	Company

END OF SECTION

SECTION 26 3600 - TRANSFER SWITCHES

PART 1 - GENERAL

1.1 SUMMARY

- A. Work included: Materials, installation and testing of:
 - 1. Open Transition Transfer Switch
 - 2. Closed Transition Transfer Switches
 - 3. Delayed Transition Transfer Switches
 - 4. Non-automatic Transfer Switches
 - 5. Microprocessor Controller
 - 6. Accessories
 - 7. Automatic Sequence of Operation

1.2 RELATED SECTIONS

- A. Contents of Division 26, Electrical, and Division 01, General Requirements apply to this Section.

1.3 REFERENCES AND STANDARDS

- A. References and Standards as required by Section 26 00 00, Electrical Basic Requirements and Division 01, General Requirements.
- B. In addition, meet the following:
 - 1. UL 1008, Automatic Transfer Switches.
 - 2. NECA 1 - Standard for Good Workmanship in Electrical Construction; National Electrical Contractors Association
 - 3. NEMA 250 - Enclosures for Electrical Equipment (1000 Volts Maximum); National Electrical Manufacturers Association
 - 4. NEMA ICS 10 Part 1 - Industrial Control and Systems Part 1: Electromechanical AC Transfer Switch Equipment; National Electrical Manufacturers Association
 - 5. NETA ATS - Acceptance Testing Specifications for Electrical Power Equipment and Systems; International Electrical Testing Association (ANSI/NETA ATS)
 - 6. NFPA 70 - National Electrical Code; National Fire Protection Association
 - 7. NFPA 110 - Standard for Emergency and Standby Power Systems; National Fire Protection Association

1.4 SUBMITTALS

- A. Submittals as required by Section 26 00 00, Electrical Basic Requirements and Division 01, General Requirements
- B. In addition, provide:
 - 1. Product Data: Provide catalog sheets showing voltage, switch size, ratings and size of switching and overcurrent protective devices, operating logic, withstand current ratings, dimensions, and enclosure details.
 - 2. Operation Data: Instructions for operating equipment under emergency conditions when engine generator is running.

3. Maintenance Data: Routine preventative maintenance and lubrication schedule. List special tools, maintenance materials, and replacement parts.

1.5 QUALITY ASSURANCE

- A. Quality assurance as required by Section 26 00 00, Electrical Basic Requirements and Division 01, General Requirements.
- B. In addition, meet the following:
 1. NFPA 70, National Electrical Code
 2. NFPA 110, Standard for Emergency and Standby Power Systems
- C. Manufacturer Qualifications: Company specializing in manufacturing the products specified in this section with minimum three years documented experience.
- D. Authorized service facilities located within 200 miles of project site.
- E. Installer Qualifications: Company specializing in performing the work of this section with minimum three years documented experience with power transfer systems of similar size, type, and complexity; manufacturer's authorized installer.
- F. Product Listing Organization Qualifications: An organization recognized by OSHA as a Nationally Recognized Testing Laboratory (NRTL) and acceptable to authorities having jurisdiction.
- G. Field Conditions: Maintain field conditions within manufacturer's required service conditions during and after installation

1.6 WARRANTY

- A. Warranty of materials and workmanship as required by Section 26 00 00, Electrical Basic Requirements and Division 01, General Requirements.
- B. Provide a comprehensive warranty that includes parts, labor, and travel to the site.

1.7 COORDINATION

- A. Coordinate the work with other trades to avoid placement of ductwork, piping, equipment, or other potential obstructions within the dedicated equipment spaces and working clearances required by NFPA 70.
- B. Coordinate arrangement of equipment with the dimensions and clearance requirements of the actual equipment to be installed.
- C. Coordinate the work with placement of supports, anchors, etc. required for mounting.
- D. Notify Architect of any conflicts with or deviations from the contract documents. Obtain direction before proceeding with work.

1.8 DELIVERY, STORAGE AND HANDLING

- A. Receive, inspect, handle, and store transfer switches in accordance with manufacturer's instructions.
- B. Store in a clean, dry space. Maintain factory wrapping or provide an additional heavy canvas or heavy plastic cover to protect units from dirt, water, construction debris, and traffic.
- C. Handle carefully in accordance with manufacturer's instructions to avoid damage to transfer switch components, enclosure, and finish.

PART 2 - PRODUCTS

2.1 MANUFACTURERS

- A. Approved manufacturers listed below are allowed on condition of meeting the specified conditions including available space allocated for the equipment (including code required working clearances) and functionality of system as described in drawings and specifications. Remove and replace electrical equipment installed and not meeting these conditions at no cost to Owner.
 - 1. ASCO Power Technologies
 - 2. Caterpillar
 - 3. Cummins
 - 4. Eaton Corporation
 - 5. Russelectric
 - 6. Or approved equivalent.
- B. Non-automatic Transfer Switches:
 - 1. ASCO
 - 2. Eaton Corporation
 - 3. ABB/General Electric
 - 4. Generac Power Systems
 - 5. Or approved equivalent.
- C. Basis of Design: Transfer switches on drawings are designed based on ASCO product line.
- D. Source Limitations: Furnish transfer switches and accessories produced by a single manufacturer and obtained from a single supplier.

2.2 OPEN TRANSITION TRANSFER SWITCH

- A. Provide open transition transfer switches where indicated on the drawings.
- B. Provide type, number of poles, amperage, voltage, withstand, and close-on ratings as indicated on drawings.
- C. Provide transfer switch rated for available fault with upstream overcurrent protection.

- D. Minimum 3-cycle (0.05 seconds) Withstand Current Rating (WCR). If required, provide 18-cycle (0.3 seconds) or 30-cycle (0.5 seconds) to accommodate selective coordination and available fault current at the installed location as indicated on the drawings.
- E. Provide NEMA Type 1 - Indoor enclosure.
- F. Transfer switch electrically operated and mechanically held. Electrical operator momentarily energized, single-solenoid mechanism. Mechanically interlocked to ensure only two possible positions, normal or emergency.
- G. Use only one type of main operator for ease of maintenance and commonality of parts.
- H. Lugs to be mechanical or tool applied compression type.
- I. Equip transfer switch(es) with bus stubs for compression lug connectors. Size and quantity of lugs as required.
- J. Positively locked and unaffected by momentary outages, so that contact pressure is maintained at constant value and contact temperature rise is minimized for maximum reliability and operating life.
- K. Contact structure to consist of main current carrying contact, silver alloy with minimum 50 percent silver content. Contacts protected by silver tungsten arching contacts on sizes above 400 amps.
- L. Inspection of contacts to be possible from front of switch without disassembly of operating linkages and without disconnection of power conductors.
- M. Designs utilizing components of molded-case circuit breakers, contactors, or parts thereof, which are not intended for continuous duty, repetitive switching or transfer between two active power sources are not acceptable.
- N. Each switch to have time delay in neutral position. Time delay adjustable from 0-5 seconds and initially set at 2 seconds. Provide means to permit neutral delay transfer switches to be driven to neutral position and held there.
- O. Construction Type: Only "contactor type" (open contact) transfer switches are acceptable. Do not use "breaker type" (enclosed contact) transfer switches.
- P. Non-Automatic Transfer Switch:
 - 1. Transfer Switch Type: As indicated on the drawings.
 - 2. Transition Configuration: As indicated on the drawings.
 - 3. Voltage: As indicated on the drawings.
 - 4. Ampere Rating: As indicated on the drawings.
 - 5. Neutral Configuration: Solid neutral (unswitched), except as indicated.
 - 6. Load Served: As indicated on the drawings.
 - 7. Primary Source: As indicated on the drawings.
 - 8. Alternate Source: As indicated on the drawings.
- Q. Switching Methods:

1. Open Transition:
 - a. Provide break-before-make transfer without a neutral position that is not connected to either source, and with interlocks to prevent simultaneous connection of the load to both sources.
 - b. Where in-phase transfer is indicated, utilize in-phase monitor to initiate transfer when phase angle difference between sources is near zero to limit in-rush currents.

- R. Enclosures:
 1. Environment Type per NEMA 250: Unless otherwise indicated, as specified for the following installation locations:
 - a. Outdoor Locations: Type 3R or Type 4.
 - b. Indoor Locations: Type 12.
 2. Provide lockable door(s) for outdoor locations.
 3. Finish: Manufacturer's standard unless otherwise indicated.

- S. Short Circuit Current Rating:
 1. Withstand and Closing Rating: Provide transfer switches, when protected by the supply side overcurrent protective devices to be installed, with listed withstand and closing rating not less than the available fault current at the installed location as indicated on the drawings.
 2. Short Time Rating: Minimum 3-cycle (0.05 seconds) Withstand Current Rating (WCR). If required, provide 18-cycle (0.3 seconds) or 30-cycle (0.5 seconds) to accommodate selective coordination and available fault current at the installed location as indicated on the drawings.

- T. Control Functions:
 1. Manual source selection.
 2. Outputs:
 - a. Auxiliary contacts; one set for each switch position.

- U. Status Indications:
 1. Connected to alternate/emergency source.
 2. Connected to primary/normal source.
 3. Alternate/emergency source available.
 4. Primary/normal source available.

- V. Remote Annunciators:
 1. Remote Annunciator Mounting: Wall-mounted; Provide flush-mounted annunciator for finished areas and surface-mounted annunciator for non-finished areas unless otherwise indicated.
 2. Transfer Switch Status Indications:
 - a. Connected to alternate/emergency source.
 - b. Connected to primary/normal source.
 - c. Alternate/emergency source available.
 - d. Primary/normal source available.

- W. Source Quality Control:
 1. See Division 01, Quality Requirements for additional requirements.

2. Perform production tests on transfer switches at factory to verify operation and performance characteristics prior to shipment. Include certified test report with submittals.

- X. Basis of Design: ASCO Power Technologies Series 7000 Open Transition Automatic Transfer Switch.

2.3 CLOSED TRANSITION TRANSFER SWITCHES

- A. Provide closed transition transfer mode for transfers between live sources, where indicated on drawings.
- B. Transfer loads without interruption (closed transition) by momentarily connecting both sources of power only when both sources are present and acceptable. Maximum interconnection time is 100 milliseconds. Closed transition transfer switch operates as conventional break-before-make (open transition) switch when power source serving load fails.
- C. Provide source differential sensing for closed transition operating mode. Sensor enables transfer/re-transfer between live sources in closed transition mode only when two sources have maximum voltage differential of 5 percent, frequency differential of 0.2 Hz and are within 5 electrical degrees. If these criteria are not met by expiration of an adjustable "fail to synch" time delay, transfer switch will default to delayed transition transfer with an adjustable off delay between sources.
- D. Include contacts to signal if ATS is in extended parallel with two sources. This alarm contact to be wired to 24 VDC shunt trips located in corresponding normal power feeder breakers as noted on drawings. 24 VDC power from trip units supplied from generator 24 VDC source battery system.
- E. Construction Type: Only "contactor type" (open contact) transfer switches are acceptable. Do not use "breaker type" (enclosed contact) transfer switches.
- F. Non-Automatic Transfer Switch:
 1. Transfer Switch Type: As indicated on the drawings.
 2. Transition Configuration: As indicated on the drawings.
 3. Voltage: As indicated on the drawings.
 4. Ampere Rating: As indicated on the drawings.
 5. Neutral Configuration: Solid neutral (unswitched), except as indicated.
 6. Load Served: As indicated on the drawings.
 7. Primary Source: As indicated on the drawings.
 8. Alternate Source: As indicated on the drawings.
- G. Switching Methods:
 1. Open Transition:
 - a. Provide break-before-make transfer without a neutral position that is not connected to either source, and with interlocks to prevent simultaneous connection of the load to both sources.
 - b. Where in-phase transfer is indicated, utilize in-phase monitor to initiate transfer when phase angle difference between sources is near zero to limit in-rush currents.

- H. Enclosures:
1. Environment Type per NEMA 250: Unless otherwise indicated, as specified for the following installation locations:
 - a. Outdoor Locations: Type 3R or Type 4.
 - b. Indoor Locations: Type 12.
 2. Provide lockable door(s) for outdoor locations.
 3. Finish: Manufacturer's standard unless otherwise indicated.
- I. Short Circuit Current Rating:
1. Withstand and Closing Rating: Provide transfer switches, when protected by the supply side overcurrent protective devices to be installed, with listed withstand and closing rating not less than the available fault current at the installed location as indicated on the drawings.
 2. Minimum 3-cycle (0.05 seconds) Withstand Current Rating (WCR). If required, provide 18-cycle (0.3 seconds) or 30-cycle (0.5 seconds) to accommodate selective coordination and available fault current at the installed location as indicated on the drawings.
- J. Control Functions:
1. Manual source selection.
 2. Outputs:
 - a. Auxiliary contacts; one set for each switch position.
- K. Status Indications:
1. Connected to alternate/emergency source.
 2. Connected to primary/normal source.
 3. Alternate/emergency source available.
 4. Primary/normal source available.
- L. Remote Annunciators:
1. Remote Annunciator Mounting: Wall-mounted; Provide flush-mounted annunciator for finished areas and surface-mounted annunciator for non-finished areas unless otherwise indicated.
 2. Transfer Switch Status Indications:
 - a. Connected to alternate/emergency source.
 - b. Connected to primary/normal source.
 - c. Alternate/emergency source available.
 - d. Primary/normal source available.
- M. Source Quality Control:
1. See Division 01, Quality Requirements for additional requirements.
 2. Perform production tests on transfer switches at factory to verify operation and performance characteristics prior to shipment. Include certified test report with submittals.
- N. Basis of Design: ASCO Power Technologies Series 7000 Closed Transition Automatic Transfer Switch.

2.4 DELAYED TRANSITION TRANSFER SWITCHES

- A. Provide delayed transition where indicated on drawings.
- B. Each switch to have time delay in neutral position. Time delay adjustable from 0-5 seconds and be initially set at 2 seconds. Provide means to permit neutral delay transfer switches to be driven to neutral position and held there.
- C. Construction Type: Only "contactor type" (open contact) transfer switches are acceptable. Do not use "breaker type" (enclosed contact) transfer switches.
- D. Non-Automatic Transfer Switch:
 - 1. Transfer Switch Type: As indicated on the drawings.
 - 2. Transition Configuration: As indicated on the drawings.
 - 3. Voltage: As indicated on the drawings.
 - 4. Ampere Rating: As indicated on the drawings.
 - 5. Neutral Configuration: Solid neutral (unswitched), except as indicated.
 - 6. Load Served: As indicated on the drawings.
 - 7. Primary Source: As indicated on the drawings.
 - 8. Alternate Source: As indicated on the drawings.
- E. Switching Methods:
 - 1. Open Transition:
 - a. Provide break-before-make transfer without a neutral position that is not connected to either source, and with interlocks to prevent simultaneous connection of the load to both sources.
 - b. Where in-phase transfer is indicated, utilize in-phase monitor to initiate transfer when phase angle difference between sources is near zero to limit in-rush currents.
- F. Enclosures:
 - 1. Environment Type per NEMA 250: Unless otherwise indicated, as specified for the following installation locations:
 - a. Outdoor Locations: Type 3R or Type 4.
 - b. Indoor Locations: Type 12.
 - 2. Provide lockable door(s) for outdoor locations.
 - 3. Finish: Manufacturer's standard unless otherwise indicated.
- G. Short Circuit Current Rating:
 - 1. Withstand and Closing Rating: Provide transfer switches, when protected by the supply side overcurrent protective devices to be installed, with listed withstand and closing rating not less than the available fault current at the installed location as indicated on the drawings.
 - 2. Short Time Rating: Minimum 3-cycle (0.05 seconds) Withstand Current Rating (WCR). If required, provide 18-cycle (0.3 seconds) or 30-cycle (0.5 seconds) to accommodate selective coordination and available fault current at the installed location as indicated on the drawings.
- H. Control Functions:
 - 1. Manual source selection.

2. Outputs:
 - a. Auxiliary contacts; one set for each switch position.
 - I. Status Indications:
 1. Connected to alternate/emergency source.
 2. Connected to primary/normal source.
 3. Alternate/emergency source available.
 4. Primary/normal source available.
 - J. Remote Annunciators:
 1. Remote Annunciator Mounting: Wall-mounted; Provide flush-mounted annunciator for finished areas and surface-mounted annunciator for non-finished areas unless otherwise indicated.
 2. Transfer Switch Status Indications:
 - a. Connected to alternate/emergency source.
 - b. Connected to primary/normal source.
 - c. Alternate/emergency source available.
 - d. Primary/normal source available.
 - K. Source Quality Control:
 1. See Division 01, Quality Requirements for additional requirements.
 2. Perform production tests on transfer switches at factory to verify operation and performance characteristics prior to shipment. Include certified test report with submittals.
 - L. Basis of Design: ASCO Power Technologies Series 7000 Delayed Transition Automatic Transfer Switch.
- 2.5 NON-AUTOMATIC TRANSFER SWITCHES
- A. Provide non-automatic transfer switches where indicated on drawings.
 - B. Description: Transfer switches with manually initiated transfer between sources; electrically operated and mechanically held.
 - C. Applications: Utilize open transition transfer unless otherwise indicated or required.
 - D. Construction Type: Only "contactor type" (open contact) transfer switches are acceptable. Do not use "breaker type" (enclosed contact) transfer switches.
 - E. Non-Automatic Transfer Switch:
 1. Transfer Switch Type: As indicated on the drawings.
 2. Transition Configuration: As indicated on the drawings.
 3. Voltage: As indicated on the drawings.
 4. Ampere Rating: As indicated on the drawings.
 5. Neutral Configuration: Solid neutral (unswitched), except as indicated.
 6. Load Served: As indicated on the drawings.
 7. Primary Source: As indicated on the drawings.
 8. Alternate Source: As indicated on the drawings.

- F. Switching Methods:
1. Open Transition:
 - a. Provide break-before-make transfer without a neutral position that is not connected to either source, and with interlocks to prevent simultaneous connection of the load to both sources.
 - b. Where in-phase transfer is indicated, utilize in-phase monitor to initiate transfer when phase angle difference between sources is near zero to limit in-rush currents.
- G. Enclosures:
1. Environment Type per NEMA 250: Unless otherwise indicated, as specified for the following installation locations:
 - a. Outdoor Locations: Type 3R or Type 4.
 - b. Indoor Locations: Type 12.
 2. Provide lockable door(s) for outdoor locations.
 3. Finish: Manufacturer's standard unless otherwise indicated.
- H. Short Circuit Current Rating:
1. Withstand and Closing Rating: Provide transfer switches, when protected by the supply side overcurrent protective devices to be installed, with listed withstand and closing rating not less than the available fault current at the installed location as indicated on the drawings.
 2. Short Time Rating: Minimum 3-cycle (0.05 seconds) Withstand Current Rating (WCR). If required, provide 18-cycle (0.3 seconds) or 30-cycle (0.5 seconds) to accommodate selective coordination and available fault current at the installed location as indicated on the drawings.
- I. Control Functions:
1. Manual source selection.
 2. Outputs:
 - a. Auxiliary contacts; one set for each switch position.
- J. Status Indications:
1. Connected to alternate/emergency source.
 2. Connected to primary/normal source.
 3. Alternate/emergency source available.
 4. Primary/normal source available.
- K. Remote Annunciators:
1. Remote Annunciator Mounting: Wall-mounted; Provide flush-mounted annunciator for finished areas and surface-mounted annunciator for non-finished areas unless otherwise indicated.
 2. Transfer Switch Status Indications:
 - a. Connected to alternate/emergency source.
 - b. Connected to primary/normal source.
 - c. Alternate/emergency source available.
 - d. Primary/normal source available.
- L. Source Quality Control:
1. See Division 01, Quality Requirements for additional requirements.

2. Perform production tests on transfer switches at factory to verify operation and performance characteristics prior to shipment. Include certified test report with submittals.

M. Basis-of-Design: ASCO Power Technologies Series 7NTS Non-Automatic Transfer Switch.

2.6 MICROPROCESSOR CONTROLLER

- A. Proved sensing and logic by single built-in microprocessor for maximum reliability, minimum maintenance, and ability to communicate serially through an optional serial communication module.
- B. Single controller to provide twelve selectable nominal voltages for maximum application flexibility and minimal spare part requirements.
 1. Voltage sensing to be true RMS type, accurate to ± 1 percent of nominal voltage.
 2. Frequency sensing accurate to ± 0.2 percent.
- C. Connect controller to transfer switch by an interconnecting wiring harness. Include keyed disconnect plug to enable controller to be disconnected from transfer switch for routine maintenance. Provide sensing and control logic on multi-layer printed circuit boards. Interfacing relays to be industrial grade plug-in type with dust covers. Enclose panel with protective cover, mounted separately from transfer switch unit for safety and ease of maintenance. Protective cover to include built-in pocket for storage of operator's manuals.
- D. Customer connections to be wired to common terminal block to simplify field-wiring connections.
- E. Controller Display and Keypad:
 1. A four line, 20 character LCD display and keypad to be an integral part of controller for viewing available data and setting desired operational parameters. Operational parameters to also be available for viewing and limited control through serial communications input port. Following parameters only to be adjustable via DIP switches on controller:
 - a. Nominal line voltage and frequency
 - b. Single or three phase sensing
 - c. Operating parameter protection
 - d. Transfer operating mode configuration (Open transition, Closed transition, or Delayed transition)
 2. Instructions and controller settings to be easily accessible, readable and accomplished without use of codes, calculations, or instruction manuals.
 3. Provide source status screens for both normal and emergency to provide digital readout of voltage on all 3 phases, frequency, and phase rotation.

2.7 ACCESSORIES

- A. Equip new transfer switches with the following time delays. Adjustable in 1 second increments, except extended parallel time which will be adjustable in 0.01 second increments.
 1. Time Delay - Adjustable 0 to 30 seconds on signal to start.
 2. Time Delay - Adjustable 0 to 60 minutes on transfer to emergency.
 3. Time Delay - Adjustable 0 to 60 minutes on re-transfer to normal after normal source failure.

4. Time Delay - Adjustable 0 to 60 minutes on re-transfer to normal after a system test.
5. Time Delay - Adjustable 0 to 60 minutes for unloaded cool down of engine generator.
6. Time Delay - Adjustable 1 to 5 minute time delay on failure to synchronize normal and emergency sources prior to closed transition transfer.
7. Time Delay - Adjustable 0.1 to 9.99 second time delay on an extended parallel condition of both power sources during closed transition operation.

- B. Continuously monitor voltage and frequency on both normal and emergency sources, with the following pickup, dropout, and trip setting capabilities (values shown as percentage of nominal unless otherwise specified):

Parameter	Sources	Dropout/Trip	Pickup/Reset
Undervoltage	N&E, 3	70 to 98%	85 to 100%
Overvoltage	N&E, 3	102 to 115%	2% below trip
Underfrequency	N&E	85 to 98%	90 to 100%
Overfrequency	N&E	102 to 110%	2% below trip
Voltage unbalance	N&E	5 to 20%	1% below dropout

- C. Provide three position momentary-type test switch for test/automatic/reset modes. Test position will simulate normal source failure. Reset position bypasses time delays on either transfer to emergency or retransfer to normal.
- D. Provide SPDT contact, rated 5 amps at 30 VDC, for a low-voltage engine start signal. Start signal prevents dry cranking of engine by requiring generator set to reach proper output, and run for duration of cool down setting, regardless of whether normal source restores before load is transferred.
- E. Provide auxiliary contacts, rated 10 amps, 250 VAC, consisting of two contacts, closed when ATS is connected to normal source and two contacts closed, when ATS is connected to emergency source, two contacts closed when normal source is available, two contacts closed when emergency source is available.
- F. Where indicated in documents, provide means to drive ATS to a center/off position upon receipt off a dry contact signal from the load shed controller.
- G. Provide signal to test transfer switches with elevator loads to prevent interruption of power during elevator operation.
- H. Provide LED indicating lights (16 mm industrial grade, type 12); one to indicate when ATS is connected to normal source (green) and one to indicate when ATS is connected to emergency source (red).
- I. Provide LED indicating lights (16 mm industrial grade, type 12), energized by controller outputs. Lights to provide true source availability of normal and emergency sources, as determined by voltage sensing trip and reset settings for each source.
- J. Data Logging - Controller to have ability to log data and to maintain last 99 events, even in event of total power loss. Following events to be time and date stamped and maintained in non-volatile memory:

1. Event Logging
 - a. Data and time and reason for transfer normal to emergency.
 - b. Data and time and reason for transfer emergency to normal.
 - c. Data and time and reason for engine start.
 - d. Data and time engine stopped.
 - e. Data and time emergency source available.
 - f. Data and time emergency source not available.
 2. Statistical Data
 - a. Total number of transfers.
 - b. Total number of transfers due to source failure.
 - c. Total number of days controller is energized.
 - d. Total number of hours both normal and emergency sources are available.
- K. Digital Power Meter: Provide a digital demand power meter at each transfer switch where indicated on plans. Install on the load side of the switch with the following functionality:
1. Provide 1 percent metering accuracy and data for the following:
 - a. Line-to-neutral voltages (VAN, VBN, VCN)
 - b. Line-to-neutral voltage average (VAVE)
 - c. Line-to-line voltages (VAB, VBC, VCA)
 - d. Line-to-line voltage average (VLAVE)
 - e. Current on each phase (IA, IB, IC)
 - f. Current in the neutral conductor (IN)
 - g. Average current (IAVE)
 - h. Active power, kW per phase and total (WA, WB, WC, WT)
 - i. Demand recording of peak kW; in intervals of: 15 minute, 30 minute, 1 hour, 1 day, 1, week, 1 month, and past 24 months
 - j. Reactive power, kVAR per phase and total (VARA, VARB, VARC, VART)
 - k. Apparent power, kVA per phase and total (VAA, VAB, VAC, VAT)
 - l. kWhours importing, exporting and net (kWhIMP, kWhEXP, kWhNET)
 - m. kVARhours leading, lagging and net (kVARhLEAD, kVARhLAG, kVARhNET)
 - n. kVAhours net (kVAhNET)
 - o. Power factor (PF)
 - p. Signal frequency (Hz)

2.8 AUTOMATIC SEQUENCE OF OPERATION

- A. Initiate Time Delay to Start Alternate Source Engine Generator: Upon initiation by normal source monitor.
- B. Time Delay To Start Alternate Source Engine Generator: 0 to 30 seconds, adjustable.
- C. Initiate Transfer Load to Alternate Source: Upon initiation by normal source monitor and permission by alternate source monitor.
- D. Time Delay Before Transfer to Alternate Power Source: 0 to 60 minutes, adjustable.
- E. Initiate Retransfer Load to Normal Source: Upon permission by normal source monitor.
- F. Time Delay Before Retransfer to Normal Power: 0 to 60 minutes, adjustable; bypass time delay in event of alternate source failure.

- G. Time Delay Before Engine Shut Down: 0 to 60 minutes, adjustable, of unloaded operation.

PART 3 - EXECUTION

3.1 GENERAL INSTALLATION REQUIREMENTS

- A. Install in accordance with manufacturer's instructions and recommendations.
- B. Provide engraved plastic nameplates under provisions of Section 26 05 53, Identification for Electrical Systems.
- C. Install arc flash labels. See Section 26 05 73, Electrical Distribution System Studies.
- D. Transfer Switches:
 - 1. Perform work in a neat and workmanlike manner in accordance with NECA 1.
 - 2. Install transfer switches in accordance with manufacturer's instructions.
 - 3. Arrange equipment to provide minimum clearances and required maintenance access.
 - 4. Provide required support and attachment in accordance with Section 26 05 29, Hangers and Supports for Electrical Systems and Equipment.
 - 5. Install transfer switches plumb and level.
 - 6. Unless otherwise indicated, mount floor-mounted transfer switches on properly sized 3 inch high concrete pad constructed in accordance with Section 03 3000, Cast-in-Place Concrete.
 - 7. Provide grounding and bonding in accordance with Section 26 05 26, Grounding and Bonding for Electrical Systems.
- E. Transfer Switch Settings:
 - 1. Time delay on signal to start: 2 seconds
 - 2. Time delay on transfer to emergency: 0 seconds
 - 3. Time delay on retransfer to normal: 10 minutes
 - 4. Time delay for engine cool down: 15 minutes
 - 5. Time delay on failure to synchronize: 30 seconds
 - 6. Time delay on extended parallel: 0.1 seconds.
- F. Examination:
 - 1. Verify that field measurements are as shown on the drawings.
 - 2. Verify that the ratings and configurations of transfer switches are consistent with the indicated requirements.
 - 3. Verify that rough-in for field connections are in the proper locations.
 - 4. Verify that mounting surfaces are ready to receive transfer switches.
 - 5. Verify that conditions are satisfactory for installation prior to starting work.
- G. Acceptance and Inspection:
 - 1. Factory test complete ATS to ensure proper operation of individual components and correct overall sequence of operation and to ensure that operating transfer time, voltage, frequency and time delay settings are in compliance with specification requirements.
 - 2. Record the following for each switch:
 - a. Time delay on retransfer to normal.

- b. Transfer switch time in neutral position during retransfer to normal for each switch with neutral delay.
 - c. Time delay to engine shut down for entire system.
 3. If transfer switch feeds UPS system, verify that voltage threshold for transfer switch is set to start generator before UPS would switch to battery power. This is to prevent running UPS on battery power during brownout that doesn't start generator.
 4. Prior to acceptance of installation, inspect and test equipment on site by equipment supplier and service tech employed and bonded by manufacturer, to show it is free of any defects and placed in service.
- H. Field Quality Control:
 1. Perform field inspection and testing in accordance with Division 01, General Requirements.
 2. Inspect and test in accordance with NETA STD ATS, except Section 4.
 3. Perform inspections and tests listed in NETA STD ATS, Section 7.22.3.
 4. See Section 01 40 00, Quality Requirements, for additional requirements.
 5. Provide services of a manufacturer's authorized representative to observe installation and assist in inspection and testing. Include manufacturer's detailed testing procedures and field reports with submittals.
 6. Prepare and start system in accordance with manufacturer's instructions.
 7. Correct defective work, adjust for proper operation, and retest until entire system complies with contract documents.
 8. Submit detailed reports indicating inspection and testing results and corrective actions taken.
- I. Closeout:
 1. Demonstrate operation of transfer switch in normal and emergency modes.
 2. See Division 01 for additional requirements for closeout submittals, demonstration and training.
 3. Demonstration: Demonstrate proper operation of transfer switches to Owner, and correct deficiencies or make adjustments as directed.
 4. Training: Train Owner's personnel on operation, adjustment, and maintenance of transfer switches.
 - a. Use operation and maintenance manual as training reference, supplemented with additional training materials as required.
 - b. Provide minimum of four hours of training.
 - c. Instructor: Manufacturer's authorized representative.
 - d. Location: At project site.
 - e. Date and Time: As selected by Owner.
- J. Cleaning and Maintenance:
 1. See Division 01, General Requirements, for additional requirements relating to maintenance service.
 2. Clean exposed surfaces to remove dirt, paint, or other foreign material and restore to match original factory finish.
- K. Testing:
 1. Reference Section 26 08 05, Electrical Acceptance Testing.

END OF SECTION

SECTION 26 5100 - LIGHTING

PART 1 - GENERAL

1.1 SUMMARY

- A. Work Included:
 - 1. Luminaires
 - 2. LED Drivers
 - 3. Lamps
- B. Provide wiring for complete and operating lighting system.

1.2 RELATED SECTIONS

- A. Contents of Division 26, Electrical and Division 01, General Requirements apply to this Section.

1.3 REFERENCES AND STANDARDS

- A. References and Standards as required by Section 26 00 00, Electrical Basic Requirements and Division 01, General Requirements.
- B. In addition, meet the following:
 - 1. NECA 500 - Commercial Lighting.
 - 2. UL 8750 – Light Emitting Diode (LED) equipment for use in lighting products.

1.4 SUBMITTALS

- A. Submittals as required by Section 26 00 00, Electrical Basic Requirements and Division 01, General Requirements.
- B. In addition, provide:
 - 1. Submit product data for:
 - a. LED Luminaires: Electrical ratings, dimensions, mounting, material, clearances, terminations, wiring, connection diagram, LM-79 photometric data, LM-80 lumen depreciation data.
 - b. LED Drivers
 - c. Lamps
 - 2. Submittal Cutsheets: Highlight, circle or otherwise graphically indicate which option(s) are being selected for the products submitted. Cutsheets that are not edited to indicate which products and options are submitted for this project or that list only catalog numbers to identify submitted options are not acceptable.
 - 3. Specified manufacturers are approved to submit bid. However, inclusion does not relieve manufacturer from supplying product as described.
 - 4. Provide the following operating and maintenance instructions as required by Section 26 00 00, Electrical Basic Requirements:
 - a. Luminaires
 - b. LED Drivers
 - c. Lamps

1.5 QUALITY ASSURANCE

- A. Quality assurance as required by Section 26 00 00, Electrical Basic Requirements and Division 01, General Requirements.
- B. In addition, meet the following:
 - 1. Provide luminaires acceptable to code authority for application and location installed.
 - 2. Comply with applicable ANSI standards.
 - 3. Comply with applicable NEMA standards.
 - 4. Provide luminaires and lampholders that comply with UL standards and have been listed and labeled for location and use indicated by a testing agency acceptable by the AHJ (e.g., UL, ETL, and the like).
 - 5. Comply with NEC as applicable to installation and construction of luminaires.
 - 6. Comply with fallout and retention requirements of IBC for diffusers, baffles, and louvers.
 - 7. Provide LED luminaires from the same manufacturer and manufacturing LED source batch for similar applications (e.g., all LED downlights from a single manufacturer and batch, all linear LED products from single manufacturer and batch).

1.6 WARRANTY

- A. Warranty as required by Section 26 00 00, Electrical Basic Requirements and Division 01, General Requirements.
- B. In addition, provide:
 - 1. LED Luminaire Manufacturer's Warranty: Not less than 5 years for luminaire based on date of substantial completion. Includes normal cost of labor to replace luminaire. Replacement luminaire will match physical dimensions, physical appearance, chromaticity, lumen output and photometric characteristics of original installed equipment.

PART 2 - PRODUCTS

2.1 MANUFACTURERS

- A. Luminaires:
 - 1. Reference description and manufacturers in Luminaire Schedule on Drawings.
 - 2. Or approved equivalent.
- B. LED Drivers:
 - 1. Indoor Drivers:
 - a. eldoLED Series
 - b. Advance/Philips
 - c. Osram Sylvania
 - d. Or approved equivalent.
 - 2. Outdoor Drivers:
 - a. Advance/Philips
 - b. Osram Sylvania
 - c. LG
 - d. Or approved equivalent.

- C. Lamps:
1. LED (Light Emitting Diode) Lamps:
 - a. Nichia
 - b. Cree
 - c. Osram Sylvania
 - d. GE Lumination
 - e. Or approved equivalent.
 2. Unless specific manufacturer not shown on this list is indicated in the Luminaire Schedule.
 3. Special types as indicated in Luminaire Schedule.
 4. Or approved equivalent.

2.2 LUMINAIRES

- A. Luminaires: Reference description and manufacturers in Luminaire Schedule on drawings.
- B. Where recessed luminaires are installed in cavities intended to be insulated, provide IC rated luminaires or other code approved installation.
- C. UL label luminaires installed under canopies, roof or open porches, and similar damp or wet locations, as suitable for damp or wet location.
- D. Suspended luminaires: Provide minimum 24-inch adjustability in aircraft cable length where used.
- E. Recessed Luminaires: Frame compatible with ceiling material installed at particular luminaire location. Provide proper factory trim and frame for luminaire to fit location and ceiling material. Verify with Architectural Reflected Ceiling Plan prior to submittals.
- F. Finishes:
1. Manufacturer's standard finish (unless otherwise indicated) over corrosion resistant primer.
 2. Interior Light Reflecting Finishes: White or specular finish with not less than 85 percent reflectance.
 3. Exterior Finishes: As detailed in Luminaire Schedule or on drawings. Refer cases of uncertain applicability to Architect for resolution prior to release for fabrication.
- G. Light Transmitting Components:
1. Plastic diffusers, molded or extruded of 100 percent virgin acrylic.
 2. Prismatic acrylic, extruded, flat diffusers, 0.125-inch overall thickness, unless otherwise noted.
- H. LED Luminaires:
1. UL listing of luminaire includes drivers, transformers, enclosures, rated wire, communications devices and accessories needed for a complete and functional system.
 2. LM-79: Testing and measurement of absolute photometry, chromaticity (CCT) and luminaire power. Report provided by DOE certified independent testing laboratory. CCT as specified in Luminaire Schedule.

3. Standards: ANSI C78.377, LM-79 and LM-82 compliant for performance characteristics, photometry, colorimetry, efficacy and thermal characteristics.
4. LM-80 + TM-21: Testing and measurement, and statistical prediction of LED lamp life. Report provided by DOE certified independent testing laboratory.
5. LEDs in one module/luminaire: Supplied from same batch/bin and fall within 3-step MacAdam Ellipse, or as described in Luminaire Schedule, whichever is the more stringent requirement.
6. Provide luminaires with integral LED thermal management system (heat sinking).
7. Luminaires to be equipped with an LED driver that accepts 120V through 277V, 50Hz to 60Hz (universal). Component-to-component wiring within the luminaire will carry no more than 80 percent of rated current and be listed by UL for use at 600VAC at 302 degrees F/150 degrees C or higher. Plug disconnects to be listed by UL for use at 600VAC, 15A or higher.
8. Provide luminaires with individual LED arrays/modules and drivers that are accessible and replaceable from exposed side of the luminaire.

2.3 LED DRIVERS

A. General:

1. Performance: Meet dimming range called out in Luminaire Schedule, free from perceived flicker or visible stroboscopic flicker, smooth and continuous change in level (no visible steps in transitions), natural square law response to control input, and stable when input voltage conditions fluctuate over what is typically experienced in a commercial environment. Demonstration of this compliance to dimming performance will be necessary for substitutions or prior approval.
2. Ten-year expected life while operating at maximum case temperature and 90 percent non-condensing relative humidity.
3. Minimum efficiency of 85 percent, power factor greater than or equal to 0.90, compliance with reduction of hazardous substances (RoHS). Rated for operating temperature range of area in which driver is installed.
4. Limit inrush current to minimize breaker tripping.
 - a. Base specification: NEMA 410 standard for inrush current for electronic drivers.
 - b. Preferred Specification: Meet or exceed 30 milliamp-squared-seconds at 277VAC for up to 50 watts of load and 75 amps at 240 microseconds at 277VAC for 100 watts of load.
5. Withstand up to a 1,000 volt surge without impairment of performance as defined by ANSI C62.41 Category A.
6. No visible change in light output with a variation of plus/minus 10 percent line voltage input.
7. Total Harmonic Distortion less than 10 percent and meet ANSI C82.11 maximum allowable THD requirements at full output. THD at no point in the dimming curve allows imbalance current to exceed full output THD.
8. Support automatic adaptation, allowing for future luminaire upgrades and enhancements and deliver improved performance:
 - a. Adjustment of forward LED voltage, supporting 3V through 55V.
 - b. Adjustment of LED current from 150mA to 1.4A at the 100 percent control input point in increments of 1mA.
 - c. Adjustment for operating hours to maintain constant lumens (within 5 percent) over the 50,000 hour design life of the system, and deliver up to 20 percent energy savings early in the life cycle.

9. Operate for a (+/- 10 percent) supply voltage of 120V through 277VAC at 60Hz.
10. UL Recognized under the component program and modular for simple field replacement. Drivers that are not UL Recognized or not suited for field replacement will not be considered.
11. Ability to provide no light output when the analog control signal drops below 0.3 V, or the DALI/DMX digital signal calls for light to be extinguished and consume 0.5 watts or less in this standby. Control dead band between 0.3V and 0.65V included to allow for voltage variation of incoming signal without causing noticeable variation in luminaire to luminaire output.

B. Light Quality:

1. Over the entire range of available drive currents, driver to provide step-free, continuous dimming to black from 100 percent to 0.1 percent and 0 percent relative light output, or 100 percent to 1 percent light output and step to 0 percent where indicated. Driver to respond similarly when raising from 0 percent to 100 percent.
 - a. Driver must be capable of 20 bit dimming resolution for white light LED drivers or 15 bit resolution for RGBW LED drivers.
2. Driver must be capable of configuring a linear or logarithmic dimming curve, allowing fine grained resolution at low light levels.
3. Drivers to track evenly across multiple luminaires at all light levels, and must have an input signal to output light level that allows smooth adjustment over the entire dimming range.
4. Driver and luminaire electronics to deliver illumination that is free from objectionable flicker as measured by flicker index (ANSI/IES RP-16-10). At all points within the dimming range from 100 percent to 0.1 percent luminaire will have:
 - a. LED dimming driver to provide continuous step-free, flicker free dimming similar to incandescent source.
 - b. Base specification: Based on IEEE PAR1789, minimum output frequency should be greater than 1250 Hz.
 - c. Preferred specification: Flicker index to be equal to incandescent, less than 1 percent at all frequencies below 1000 Hz.

C. Control Input:

1. Provide control protocol to match lighting control system specified for use with luminaire.
2. 4-Wire (0-10V DC Voltage Controlled) Dimming Drivers:
 - a. Meet IEC 60929 Annex E for General White Lighting LED drivers.
 - b. Connect to devices compatible with 0 to 10V Analog Control Protocol, Class 2, capable of sinking 0.6 ma per driver at a low end of 0.3V. Limit the number of drivers on each 0-10V control output based on voltage drop and control capacity.
 - c. Meet ESTA E1.3 for RGBW LED drivers.

2.4 LAMPS

- A. Provide lamps for luminaires.
- B. Provide lamp catalogued for specified luminaire type.
- C. Incandescent Lamps: Not allowed unless noted in Luminaire Schedule.

- D. LED (Light Emitting Diode):
1. LED manufacturer will include, but not be limited to, light source, luminaire, power supply and control interface with added components as needed for complete and functioning system.
 - a. Comply with ANSI chromaticity standard for classifications of color temperature. See Luminaire Schedule for specified LED lamp color and color temperature. UL or ETL listed and labeled.
 - b. Luminaire testing per IESNA LM-79 and LM-80 procedures.
 - c. Lamp life for white LEDs: 50,000 plus hours with lamp failure occurring when LED produces 70 percent of initial rated lumens.
 - d. Lamp life for color LEDs: 30,000 plus hours with lamp failure occurring when LED produces 50 percent of its initial rated lumens.
 - e. LED Drivers: Reverse polarity protection, open circuit protection, require no minimum load. Minimum 80 percent efficiency. Class A noise rating.
 - f. Dimming: LED system capable of full and continuous dimming.
 - g. Correlated Color Temperature (CCT): See Luminaire Schedule for selection of color temperature for each luminaire. Ranges given below reflect maximum allowable tolerances for color temperature range for each nominal CCT.
 - 1) Nominal CCT:
 - (a) 2700 K (2725 ± 145)
 - (b) 3000 K (3045 ± 175)
 - (c) 3500 K (3465 ± 245)
 - (d) 4000 K (3985 ± 275)
 - h. Color Rendering Index (CRI) to be greater than or equal to 80.
 2. Special types as indicated in Luminaire Schedule.

PART 3 - EXECUTION

3.1 GENERAL INSTALLATION REQUIREMENTS

- A. Install per manufacturer's written installation instructions and requirements.
- B. Install luminaires securely, in neat and workmanlike manner.
- C. Install luminaires of types indicated where shown and at indicated heights in accordance with manufacturer's written instructions and with recognized industry practices to ensure that luminaires comply with requirements and serve intended purposes.
- D. Wiring:
 1. Recessed luminaires to be installed using flexible metallic conduit or MC Cable as allowed by Section 26 0519 with luminaire conductors spliced to branch circuit conductors in nearby accessible junction box over ceiling. Junction box fastened to building structural member within 6-feet of luminaire.
 2. Luminaires for lift out and removal from ceiling pattern without disconnecting conductors or defacing ceiling materials.
 3. Flexible connections where permitted to exposed luminaires; neat and straight, without excess slack, attached to support device.
 4. Install junction box, flexible conduit and high temperature insulated conductors for through wiring of recessed luminaires.

- E. Relamp luminaires which have failed lamps at substantial completion.
- F. Replace LED drivers deemed as excessively noisy by Architect, Engineer, or Owner.
- G. Install suspended luminaires and exit signs using pendants supported from swivel hangers. Provide pendant length required to suspend luminaire at indicated height.
- H. Support luminaires larger than 2- by 4-foot size independent of ceiling framing.
- I. Locate recessed ceiling luminaires as indicated on architectural reflected ceiling plan.
- J. Install surface mounted luminaires and exit signs plumb and adjust to align with building lines and with each other. Secure to prevent movement.
- K. Exposed Grid Ceilings:
 - 1. Support surface mounted luminaires in grid ceiling directly from building structure.
 - 2. Provide auxiliary members spanning ceiling grid members to support surface mounted luminaires.
 - 3. Fasten surface mounted luminaires to ceiling grid members using bolts, screws, rivets, or suitable clips.
- L. Install recessed luminaires to permit removal from below.
- M. Install recessed luminaires using accessories and firestopping materials to meet regulatory requirements for fire rating.
- N. Install clips to secure recessed grid-supported luminaires in place.
- O. Install wall mounted luminaires, emergency lighting units, and exit signs at height as indicated on Architectural Drawings.
- P. Install accessories furnished with each luminaire.
- Q. Make wiring connections to branch circuit using building wire with insulation suitable for temperature conditions within luminaire.
- R. Bond products and metal accessories to branch circuit equipment grounding conductor.
- S. Install specified lamps in each emergency lighting unit, exit sign, and luminaire.
- T. Where manufactured wiring assemblies are used, ensure that wiring assembly manufacturer sends components to appropriate luminaire manufacturer for respective installation of proper components.
- U. Coordination:
 - 1. Coordination of Conditions: Coordinate ceiling construction, recessing depth and other construction details prior to ordering luminaires for shipment. Refer cases of uncertain applicability to Architect for resolution prior to release of luminaires for shipment. Where luminaires supplied do not match ceiling construction, replace luminaires at no cost to Owner.

2. Electrical drawings are schematic, identifying quantity and type of luminaires used and their approximate location, but are not to be used for dimensional purposes. Reference architectural drawings for exact locations, including mounting heights.
3. Provide lighting indicated on drawings with luminaire of the type designated and appropriate for location.
4. Provide LED luminaires with driver compatible to lighting control system as shown in drawings and as specified.
5. Where remote drivers are required, ensure adequate accessibility to driver. Upsize conductors between luminaire and driver to accommodate voltage drop.

V. Field Quality Control:

1. Perform field inspection in accordance with Division 01, General Requirements.
2. Operate each luminaire after installation and connection. Inspect for proper connection and operation.

W. Cleaning:

1. Clean electrical parts to remove conductive and deleterious materials.
2. Remove dirt and debris from enclosures.
3. Clean paint splatters, dirt, dust, fingerprints, and debris from luminaires.
4. Clean photometric control surfaces as recommended by manufacturer.
5. Clean finishes and touch up damaged finishes per by manufacturer's instructions.

X. Demonstrate luminaire operation for minimum of two hours.

3.2 LUMINAIRES

- A. Install per manufacturer's written installation instructions and requirements.
- B. Align, mount and level luminaires uniformly. Use ball hangers for suspended stem mounted luminaires.
- C. Avoid interference with and provide clearance from equipment. Where indicated locations for luminaires conflict with locations for equipment, change locations for luminaire by minimum distance necessary as directed by Architect.
- D. Suspended Luminaires: Mounting heights indicate clearances between bottom of luminaire and finished floors.
- E. Emergency Egress Luminaires: Provide unswitched circuit for battery charging and autotransfer circuiting for exit signs. Where test switch cannot be integral to luminaire, mount remote test switch flush-to-ceiling and adjacent to egress luminaire.
- F. Interior Luminaire Supports:
 1. Support Luminaires: Anchor supports to structural slab or to structural members within a partition, or above a suspended ceiling.
 2. Maintain luminaire positions after cleaning and relamping.
 3. Support luminaires without causing ceiling or partition to deflect.
 4. Provide mounting supports for recessed and pendant mounted luminaires as required by IBC.

G. Adjusting:

1. Aim and adjust luminaires as indicated.
2. Focus and adjust floodlights, spotlights and other adjustable luminaires, with Architect, at such time of day or night as required.
3. Align luminaires that are not straight and parallel/perpendicular to structure.
4. Position exit sign directional arrows as indicated.

3.3 LED DRIVERS

- A. Install lamps per manufacturer's installation instructions and requirements.
- B. Where driver is remote mounted, size wiring based on type of driver, driver distance from luminaire, and voltage/power level, and manufacturer's installation instructions.
- C. Protect 0-10V input from line voltage mis-connection, and so it will be immune and the output unresponsive to induced AC voltage on the control leads.

END OF SECTION

SECTION 28 0001 - ELECTRONIC SAFETY BASIC REQUIREMENTS

PART 1 - GENERAL

1.1 DESIGN-BUILD SUMMARY

- A. Work included in 28 00 01 applies to Division 28, Electronic Safety work to provide materials, labor, tools, permits and incidentals to make electronic safety systems ready for Owner's use for proposed project.

1.2 DESIGN-BUILD INSTRUCTIONS

- A. This document is issued to give Bidders a basis for preparing a proposal to design and install a complete Electronic Safety system for this project.
- B. Alternates to this Document may be offered as a separate proposal.

1.3 DESIGN-BUILD DESIGN APPROACH

- A. Use this Specification as a guide for design/engineering requirements, workmanship and materials or construction. Utilize design-build concept throughout construction phase of project.
- B. Investigate and be apprised of applicable codes, rules, and regulations as enforced by AHJ.
- C. Visit the Site of the proposed construction. Verify and inspect the existing site to determine conditions that affect this work.

1.4 DESIGN-BUILD DESIGN CRITERIA/CALCULATIONS

- A. Related Work Specified Elsewhere:
 - 1. Contents of Section apply to Division 28, Electronic Safety Specifications.
 - 2. Requirements of Section are a minimum for Division 28, Electronic Safety Sections, unless otherwise stated in each Section, in which case that Section's requirements take precedence.
- B. Fire Alarm Design Criteria: Refer to Section 28 31 00, Fire Detection and Alarm, for fire alarm system design criteria.
- C. Fire Alarm Equipment: Refer to Section 28 31 00, Fire Detection and Alarm, for fire alarm equipment requirements.

1.5 SECTION INCLUDES

- A. Work included in 28 00 01, Electronic Safety Basic Requirements applies to Division 28, Electronic Safety work to provide materials, labor, tools, permits, incidentals, and other services to provide and make ready for Owner's use of electronic safety systems for proposed project.
- B. Contract Documents include, but are not limited to, Specifications including Division 00, Procurement and Contracting Requirements and Division 01, General Requirements, Drawings, Addenda, Owner/Architect Agreement, and Owner/Contractor Agreement. Confirm requirements before commencement of work.

C. Definitions:

1. Provide: To furnish and install, complete and ready for intended use.
2. Furnish: Supply and deliver to project site, ready for unpacking, assembly and installation.
3. Install: Includes unloading, unpacking, assembling, erecting, installing, applying, finishing, protecting, cleaning and similar operations at project site as required to complete items of work furnished.
4. Approved or Approved Equivalent: To possess the same performance qualities and characteristics and fulfill the utilitarian function without any decrease in quality, durability or longevity. For equipment/products defined by the Contractor as "equivalent," substitution requests must be submitted to Engineer for consideration, in accordance with Division 01, General Requirements, and approved by the Engineer prior to submitting bids for substituted items.
5. Authority Having Jurisdiction (AHJ): Indicates reviewing authorities having jurisdiction, including local fire marshal, Owner's insurance underwriter, Owner's Authorized Representative, and other reviewing entity whose approval is required to obtain systems acceptance.

1.6 RELATED SECTIONS

- A. Contents of Section apply to Division 28, Electronic Safety Contract Documents.
- B. Related Work:
 1. Additional conditions apply to this Division including, but not limited to:
 - a. Specifications including Division 00, Procurement and Contracting Requirements and Division 01, General Requirements.
 - b. Drawings
 - c. Addenda
 - d. Owner/Architect Agreement
 - e. Owner/Contractor Agreement
 - f. Codes, Standards, Public Ordinances and Permits
- C. Contents of Division 26, Electrical apply to this Section.

1.7 REFERENCES AND STANDARDS

- A. References and Standards per Division 00, Procurement and Contracting Requirements and Division 01, General Requirements, individual Division 28, Electronic Safety Sections and those listed in this Section.
- B. Codes to include latest adopted editions, including current amendments, supplements and local jurisdiction requirements in effect as of the date of the Contract Documents, of/from:
 1. State of Virginia:
 - a. 2012 International Building Code (IBC) with corresponding Virginia Construction Code Supplement
 - b. 2012 International Mechanical Code (IMC) with corresponding Virginia Construction Code Supplement
 - c. 2012 International Plumbing Code (IPC) with corresponding Virginia Construction Code Supplement

- d. 2012 International Fuel Gas Code (IFGC) with corresponding Virginia Construction Code Supplement
 - e. 2012 National Electric Code (NFPA 70-2011) with corresponding Virginia Construction Code Supplement
 - f. 2012 International Energy Conservation Code (IECC) with corresponding Virginia Construction Code Supplement
- C. Reference standards and guidelines include but are not limited to the latest adopted editions from:
1. ABA - Architectural Barriers Act
 2. ADA - Americans with Disabilities Act
 3. ANSI - American National Standards Institute
 4. ASCE - American Society of Civil Engineers
 5. ASHRAE - American Society of Heating, Refrigerating and Air-Conditioning Engineers
 6. ASHRAE Guideline 0, the Commissioning Process
 7. ASME - American Society of Mechanical Engineers
 8. ASTM - ASTM International
 9. CFR - Code of Federal Regulations
 10. EPA - Environmental Protection Agency
 11. ETL - Electrical Testing Laboratories
 12. FM - FM Global
 13. ISO - International Organization for Standardization
 14. NEC - National Electric Code
 15. NEMA - National Electrical Manufacturers Association
 16. NFPA - National Fire Protection Association
 17. OSHA - Occupational Safety and Health Administration
 18. SMACNA - Sheet Metal and Air Conditioning Contractors' National Association
 19. UL - Underwriters Laboratories Inc.
- D. See Division 28, Electronic Safety individual Sections for additional references.

1.8 SUBMITTALS

- A. See Division 01, General Requirements for Submittal Procedures.
- B. Provide drawings in format and software release equal to the design documents. Drawings to be the same sheet size and scale as the Contract Documents.
- C. "No Exception Taken" constitutes that review is for general conformance with the design concept expressed in the Contract Documents for the limited purpose of checking for conformance with information given. Any action is subject to the requirements of the Contract Documents. Contractor is responsible for the dimensions and quantity and will confirm and correlate at the job site, fabrication processes and techniques of construction, coordination of the work with that of all other trades, and the satisfactory performance of the work.
- D. Provide product submittals and shop drawings in electronic format only. Electronic format must be submitted via zip file via e-mail. For electronic format, provide one file per division containing one bookmarked PDF file with each bookmark corresponding to each Specification Section. Arrange bookmarks in ascending order of Specification Section number. Individual

submittals sent piecemeal in a per Specification Section method will be returned without review or comment. Copy Architect on all transmissions/submissions.

- E. Product Data: Provide manufacturer's descriptive literature for products specified in Division 28, Electronic Safety Sections.
- F. Identify/mark each submittal in detail. Note what difference, if any, exist between the submitted item and the specified item. Failure to identify the differences will be considered cause for disapproval. If differences are not identified and/or not discovered during the submittal review process, Contractor remains responsible for providing equipment and materials that meet the specifications and drawings.
 - 1. Label submittal to match numbering/references as shown in Contract Documents. Highlight and label applicable information to individual equipment or cross out/remove extraneous data not applicable to submitted model. Clearly note options and accessories to be provided, including field installed items. Highlight connections by/to other trades.
 - 2. Include technical data, installation instructions and dimensioned drawings for products, equipment and devices installed, furnished or provided. Reference individual Division 28, Electronic Safety specification Sections for specific items required in product data submittal outside of these requirements.
 - 3. See Division 28, Electronic Safety individual Sections for additional submittal requirements outside of these requirements.
- G. Maximum of two reviews of complete submittal package. Arrange for additional reviews and/or early review of long-lead items; Bear costs of additional reviews at Engineer's hourly rates. Incomplete submittal packages/submittals will be returned to contractor without review.
- H. Resubmission Requirements: Make corrections or changes in submittals as required, and in consideration of Engineer's comments. Identify Engineer's comments and provide an individual response to each of the Engineer's comments. Cloud changes in the submittals and further identify changes which are in response to Engineer's comments.
- I. Trade Coordination: Include physical characteristics, electrical characteristics, device layout plans, wiring diagrams, and connections as required per Division 28, Electronic Safety Coordination Documents. For equipment with electrical connections, furnish copy of approved submittal for inclusion in Division 26, Electrical and Division 28, Electronic Safety submittals.
- J. Make provisions for openings in building for admittance of equipment prior to start of construction or ordering of equipment.
- K. Substitutions and Variation from Basis of Design:
 - 1. The Basis of Design designated product establishes the qualities and characteristics for the evaluation of any comparable products by other listed acceptable manufacturers if included in this Specification or included in an approved Substitution Request as judged by the Design Professional.
 - 2. If substitutions and/or equivalent equipment/products are being proposed, it is the responsibility of parties concerned, involved in, and furnishing the substitute and/or equivalent equipment to verify and compare the characteristics and requirements of that furnished to that specified and/or shown. If greater capacity and/or more materials and/or more labor are required for the rough-in, circuitry or connections than for the item specified and provided for, then provide compensation for additional charges required for the proper rough-in, circuitry and connections for the equipment being furnished. No

additional charges above the Base Bid, including resulting charges for work performed under other Divisions, will be allowed for such revisions. Coordinate with the requirements of "Submittals." For any product marked "or approved equivalent," a substitution request must be submitted to Engineer for approval prior to purchase, delivery or installation.

3. Where manufacturer equipment or model numbers are indicated with no exceptions, substitutions will be rejected.
- L. Shop Drawings:
1. Provide coordinated shop drawings which include physical characteristics of all systems, device layout plans, and control wiring diagrams. Reference individual Division 28, Electronic Safety specification Sections for additional requirements for shop drawings outside of these requirements.
 2. Provide Shop Drawings indicating access panel locations, size and elevation for approval prior to installation.
- M. Samples: Provide samples when requested by individual Sections.
- N. Resubmission Requirements:
1. Make any corrections or change in submittals when required by Architect/Engineer review comments. Provide submittals as specified. The engineer will not be required to edit and/or interpret the Contractor's submittals. Indicate changes for the resubmittal in a cover letter with reference to page(s) changed and reference response to comment. Cloud changes in the submittals.
 2. Resubmit for review until review indicates no exception taken or "make corrections noted."
 3. When submitting drawings for Engineers re-review, clearly indicate changes on drawings and "cloud" any revisions. Submit a list describing each change.
- O. Operation and Maintenance Manuals, Owner's Instructions:
1. Reference individual Division 28, Electronic Safety Specification Sections for additional requirements for operations and maintenance manuals.
 2. Submit, at one time, electronic files (PDF format) of manufacturer's operation and maintenance instruction manuals and parts lists for equipment or items requiring servicing. Submit data when work is substantially complete and in same order format as submittals. Include name and location of source parts and service for each piece of equipment.
 - a. Include copy of approved submittal data along with submittal review letters received from Engineer. Data to clearly indicate installed equipment model numbers. Delete or cross out data pertaining to other equipment not specific to this project.
 - b. Include copy of manufacturer's standard Operations and Maintenance for equipment. At front of each tab, provide routine maintenance documentation for scheduled equipment. Include manufacturer's recommended maintenance schedule and highlight maintenance required to maintain warranty. Furnish list of routine maintenance parts, including part numbers, sizes and quantities relevant to each piece of equipment.
 - c. Include copy of complete parts list for equipment. Include available exploded views of assemblies and sub-assemblies.

- d. Include Warranty per Division 00, Procurement and Contracting Requirements, Division 01, General Requirements, Section 28 00 01, Electronic Safety Basic Requirements and individual Sections.
 - e. Include product certificates of warranties and guarantees.
 - f. Include copy of start-up and test reports specific to each piece of equipment.
 - g. Include commissioning reports.
 - h. Engineer will return incomplete documentation without review.
 - i. Engineer will provide one set of review comments in Submittal Review format. Arrange for additional reviews; Bear costs for additional reviews at Engineer's hourly rates.
3. Thoroughly instruct Owner in proper operation of equipment and systems. Where noted in individual Sections, training will include classroom instruction with applicable training aids and systems demonstrations. Field instruction per Section 28 00 01, Electronic Safety Basic Requirements Article titled "Demonstration."
 4. Copies of certificates of code authority inspections, acceptance, code required acceptance tests, letter of conformance and other special guarantees, certificates of warranties, specified elsewhere or indicated on Drawings.
- P. Record Drawings:
1. Maintain at site at least one set of drawings for recording "as-constructed" conditions. Indicate on drawings changes to original documents by referencing revision document, and include buried elements and location of concealed items. Include items changed by addenda, field orders, supplemental instructions, and constructed conditions.
 2. Record Drawings are to include equipment locations, calculations, and schedules that accurately reflect "as constructed or installed" for project.
 3. At completion of project, input changes to original project on Revit Model and make one set of black-line drawings created from Revit Model in version/release equal to contract drawings. Submit Revit disk and drawings upon substantial completion.
 4. See Division 28, Electronic Safety individual Sections for additional items to include in Record Drawings.

1.9 QUALITY ASSURANCE

- A. Regulatory Requirements: Work and materials installed to conform with all local, State and Federal codes, and other applicable laws and regulations. Where code requirements are at variance with Contract Documents, meet code requirements as a minimum requirement and include costs necessary to meet these in Contract. Machinery and equipment are to comply with OSHA requirements, as currently revised and interpreted for equipment manufacturer requirements. Install equipment provided per manufacturer recommendations.
- B. Whenever this Specification calls for material, workmanship, arrangement or construction of higher quality and/or capacity than that required by governing codes, higher quality and/or capacity take precedence.
- C. Drawings are intended to be diagrammatic and reflect the Basis of Design manufacturer's equipment. They are not intended to show every item in its exact dimensions, or details of equipment or proposed systems layout. Verify actual dimensions of systems (e.g. cable tray, panels, etc.) and equipment proposed to assure that systems and equipment will fit in available space. Contractor is responsible for design and construction costs incurred for equipment other

than Basis of Design, including, but not limited to, architectural, structural, electrical, HVAC, fire sprinkler, and plumbing systems.

- D. Manufacturer's Instructions: Follow manufacturer's written instructions. If in conflict with Contract Documents, obtain clarification. Notify Engineer/Architect, in writing, before starting work.
- E. Items shown on Drawings are not necessarily included in Specifications or vice versa. Confirm requirements in all Contract Documents.
- F. Provide products that are UL listed.

1.10 WARRANTY

- A. Provide written warranty covering the work for a period of one year from date of Substantial Completion in accordance with Division 00, Procurement and Contracting Requirements and Division 01, General Requirements, Section 28 00 01, Electronic Safety Basic Requirements and individual Division 28, Electronic Safety Sections.
- B. Sections under this Division can require additional and/or extended warranties that apply beyond basic warranty under Division 01, General Requirements and the General Conditions. Confirm requirements in all Contract Documents.

1.11 COORDINATION DOCUMENTS

- A. Prior to construction, coordinate installation and location of HVAC equipment, ductwork, grilles, diffusers, piping, plumbing equipment/fixtures, fire sprinklers, plumbing, cable trays, lights, and electrical services with architectural and structural requirements, and other trades (including ceiling suspension and tile systems), and provide maintenance access requirements. Coordinate with submitted architectural systems (i.e. roofing, ceiling, finishes) and structural systems as submitted, including footings and foundation. Identify zone of influence from footings and ensure systems are not routed within the zone of influence.
- B. Advise Architect in event a conflict occurs in location or connection of equipment. Bear costs resulting from failure to properly coordinate installation or failure to advise Architect of conflict.
- C. Verify in field exact size, location, and clearances of existing material, equipment and apparatus, and advise Architect of discrepancies between that indicated on Drawings and that existing in field prior to installation related thereto.
- D. Submit final Coordination Drawings with changes as Record Drawings at completion of project.

1.12 VIRIDIANT REQUIREMENTS

- A. Project seeks Net-Zero ready, as outlined by Viridiant's Residential Net-Zero program.
- B. Obtain list of credits sought by project. Be familiar with requirements for credits. See Division 00, Procurement and Contracting Requirements and Division 01, General Requirements for requirements.

- C. Provide materials and services as outlined in appropriate Viridiant Residential Net-Zero Reference Guide.
- D. Provide documentation as outlined in appropriate Viridiant Residential Net-Zero Reference Guide.
- E. Coordinate start-up, testing, training, and installation with Commissioning Agent as required to meet commissioning requirements.
- F. Provide adequate schedule for construction activities such as building flush out.

PART 2 - PRODUCTS

2.1 MANUFACTURERS

- A. Articles, fixtures, and equipment of a kind to be standard product of one manufacture, including but not limited to panels, devices and equipment unless otherwise specified in individual Division 28, Electronic Safety Sections.

2.2 STANDARDS OF MATERIALS AND WORKMANSHIP

- A. Base contract upon furnishing materials as specified. Materials, equipment, and fixtures used for construction are to be new, latest products as listed in manufacturer's printed catalog data and are to be UL or FM approved or have adequate approval or be acceptable by state, county, and city authorities.
- B. Names and manufacturer's names denote character and quality of equipment desired and are not to be construed as limiting competition.
- C. Hazardous Materials:
 - 1. Comply with local, State of Virginia, and Federal regulations relating to hazardous materials.
 - 2. Comply with Division 00, Procurement and Contracting Requirements and Division 01, General Requirements for this project relating to hazardous materials.
 - 3. Do not use any materials containing a hazardous substance. If hazardous materials are encountered, do not disturb; immediately notify Owner and Architect. Hazardous materials will be removed by Owner under separate contract.

PART 3 - EXECUTION

3.1 ACCESSIBILITY AND INSTALLATION

- A. Confirm Accessibility and Installation requirements in Division 00, Procurement and Contracting Requirements, Division 01, General Requirements, Section 28 00 01, Electronic Safety Basic Requirements and individual Division 28, Electronic Safety Sections.
- B. Install equipment having components requiring access (i.e., devices, equipment, electrical boxes, panels, etc.) so that they may be serviced, reset, replaced or recalibrated by service people with normal service tools and equipment. Do not install equipment in obvious passageways, doorways, scuttles or crawlspaces which would impede or block intended usage.

- C. Install equipment and products complete as directed by manufacturer's installation instructions. Obtain installation instructions from manufacturer prior to rough-in of equipment and examine instructions thoroughly. When requirements of installation instructions conflict with Contract Documents, request clarification from Architect prior to proceeding with installation. This includes proper installation methods, sequencing and coordination with other trades and disciplines.
- D. Earthwork:
 - 1. Confirm Earthwork requirements in Contract Documents. In absence of specific requirements, comply with individual Division 28, Electronic Safety Sections and the following:
 - a. Perform excavation, dewatering, shoring, bedding, and backfill required for installation of work in this Division in accordance with related earthwork divisions. Contact utilities and locate existing utilities prior to excavation. Repair any work damaged during excavation or backfilling.
 - b. Excavation: Do not excavate under footings, foundation bases, or retaining walls.
 - c. Provide protection of underground systems. Review the project Geotechnical Report for references to corrosive or deleterious soils which will reduce the performance or service life of underground systems materials.
- E. Firestopping:
 - 1. Confirm Firestopping requirements in Division 07, Thermal and Moisture Protection.
 - 2. In absence of specific requirements, comply with individual Division 28, Electronic Safety Sections and coordinate location and protection level of fire and/or smoke rated walls, ceilings, and floors. When these assemblies are penetrated, seal around conduit, raceway and equipment with approved firestopping material. Install firestopping material complete as directed by manufacturer's installation instructions. Meet requirements of ASTM E814, Standard Test Method for Fire Tests of Through-Penetration Fire Stops.
- F. Plenums: In plenums, provide plenum rated materials that meet the requirements to be installed in plenums.

3.2 REVIEW AND OBSERVATION

- A. Confirm Review and Observation requirements in Division 00, Procurement and Contracting Requirements, Division 01, General Requirements, Section 28 00 01, Electronic Safety Basic Requirements and individual Division 28, Electronic Safety Sections.
- B. Notify Architect, in writing, at following stages of construction so that they may, at their option, visit site for review and construction observation:
 - 1. Underground conduit and wire installation prior to backfilling.
 - 2. Prior to covering walls when electronic safety systems installation is started.
 - 3. Prior to ceiling cover/installation.
 - 4. When main systems, or portions of, are being tested and ready for inspection by AHJ.
- C. Final Punch: Costs incurred by additional trips required due to incomplete systems will be the responsibility of the Contractor.

3.3 CONTINUITY OF SERVICE

- A. Confirm requirements in Division 00, Procurement and Contracting Requirements and Division 01, General Requirements. In absence of specific requirements in Division 01, General Requirements, comply with individual Division 28, Electronic Safety Sections and the following:
1. During remodeling or addition to existing structures, while existing structure is occupied, current services to remain intact until new construction, facilities or equipment is installed.
 2. Prior to changing over to new system, verify that every item is thoroughly prepared. Install new wiring to point of connection.
 3. Coordinate transfer time to new service with Owner. If required, perform transfer during off peak hours. Once changeover is started, pursue to its completion to keep interference to a minimum. If overtime is necessary, there will be no allowance made by Owner for extra expense for such overtime or shift work.
 4. Organize work to minimize duration of power interruption.

3.4 CUTTING AND PATCHING

- A. Confirm Cutting and Patching Requirements in Division 00, Procurement and Contracting Requirements and Division 01, General Requirements. In absence of specific requirements, comply with individual Division 28, Electronic Safety Sections and the following:
1. Proposed floor cutting/core drilling/sleeve locations to be approved by Project Structural Engineer. Submit proposed locations to Architect/Project Structural Engineer. Where slabs are of post tension construction, perform x-ray scan of proposed penetration locations and submit scan results including proposed penetration locations to Project Structural Engineer/Architect for approval. Where slabs are of waffle type construction, show column cap extent and cell locations relative to proposed penetration(s).
 2. Cutting, patching and repairing for work specified in this Division including plastering, masonry work, concrete work, carpentry work, and painting included under this Section will be performed by skilled craftsmen of each respective trade in conformance with appropriate Division of Work.
 3. Additional openings required in building construction to be made by drilling or cutting. Use of jack hammer is specifically prohibited. Patch openings in and through concrete and masonry with grout.
 4. Restore new or existing work that is cut and/or damaged to original condition. Patch and repair specifically where existing items have been removed. This includes repairing and painting walls, ceilings, etc. where existing conduit and devices are removed as part of this project. Where alterations disturb lawns, paving, and walks, repair, refinish and leave in condition matching existing prior to commencement of work.
 5. Additional work required by lack of proper coordination will be provided at no additional cost to the Owner.

3.5 EQUIPMENT SELECTION AND SERVICEABILITY

- A. Replace or reposition equipment which is too large or located incorrectly to permit servicing, at no additional cost to Owner.

3.6 DELIVERY, STORAGE AND HANDLING

- A. Confirm requirements in Division 00, Procurement and Contracting Requirements and Division 01, General Requirements. In absence of specific requirements, comply with the individual Division 28, Electronic Safety Sections and the following:
 - 1. Handle materials delivered to project site with care to avoid damage. Store materials on site inside building or protected from weather, dirt and construction dust.
 - 2. Protect equipment and pipe to avoid damage. Close conduit openings with caps or plugs. Keep motors and bearings in watertight and dustproof covers during entire course of installation.
 - 3. Protect devices, panels and similar items until in service.
 - 4. Products and/or materials that become damaged due to water, dirt and/or dust as a result of improper storage to be replaced before installation.

3.7 DEMONSTRATION

- A. Confirm Demonstration requirements in Division 00, Procurement and Contracting Requirements and Division 01, General Requirements, Section 28 00 01, Electronic Safety Basic Requirements and individual Division 28, Electronic Safety Sections.
- B. Upon completion of work and adjustment of equipment, test systems, demonstrate to Owner's Authorized Representative, Architect and Engineer that equipment furnished and installed or connected under provisions of these Specifications functions in manner required. Provide field instruction to Owner's Staff as specified in Division 01, General Requirements, Section 28 00 01, Electronic Safety Basic Requirements and individual Division 28, Electronic Safety Sections.
- C. Manufacturer's Field Services: Furnish services of a qualified factory certified instructor at time approved by Owner, to instruct maintenance personnel, correct defects or deficiencies, and demonstrate to satisfaction of Owner that entire system is operating in satisfactory manner and complies with requirements of other trades that may be required to complete work. Complete instruction and demonstration prior to final job site observations.

3.8 CLEANING

- A. Confirm cleaning requirements in Division 00, Procurement and Contracting Requirements, Division 01, General Requirements, Section 28 00 01, Electronic Safety Basic Requirements and individual Division 28 Sections.
- B. Upon completion of installation, thoroughly clean exposed portions of equipment, removing temporary labels and traces of foreign substances. Throughout work, remove construction debris and surplus materials accumulated during work.

3.9 INSTALLATION

- A. Confirm Installation requirements in Division 00, Procurement and Contracting Requirements, Division 01, General Requirements, Section 28 00 01, Electronic Safety Basic Requirements and individual Division 28, Electronic Safety Sections.

- B. Install equipment in accordance with manufacturer's installation instructions, plumb and level and firmly anchored to building structure. Maintain manufacturer's recommended clearances.
- C. Start up equipment, in accordance with manufacturer's start-up instructions, and in presence of manufacturer's representative. Test controls and demonstrate compliance with requirements. Replace damaged or malfunctioning controls and equipment.
- D. Provide miscellaneous supports required for installation of equipment, conduit and wiring.

3.10 PAINTING

- A. Confirm Painting requirements in Division 01, General Requirements and Division 09, Finishes. In absence of specific requirements, comply with individual Division 28, Electronic Safety Sections and the following:
 - 1. Ferrous Metal: After completion of work, thoroughly clean and paint exposed supports constructed of ferrous metal surfaces, i.e. hangers, hanger rods, equipment stands, with one coat of black asphalt varnish for exterior or black enamel for interior, suitable for hot surfaces.
 - 2. In electrical and mechanical room, on roof or other exposed areas, equipment not painted with enamel to receive two coats of primer and one coat of rustproof enamel, colors as selected by Architect.
 - 3. See individual equipment Specifications for other painting.
 - 4. Structural Steel: Repair damage to structural steel finishes or finishes of other materials damaged by cutting, welding or patching to match original.
 - 5. Conduit: Clean, primer coat and paint interior conduit exposed in finished areas with two coats paint suitable for metallic surfaces. Color selected by Architect.

3.11 ACCEPTANCE

- A. Confirm requirements in Division 00, Procurement and Contracting Requirements and Division 01, General Requirements. In absence of specific requirements, comply with individual Division 28, Electronic Safety Sections and the following:
 - 1. System cannot be considered for acceptance until work is completed and demonstrated to Architect that installation is in strict compliance with Specifications, Drawings and manufacturer's installation instructions, particularly in reference to following:
 - a. Cleaning
 - b. Operation and Maintenance Manuals
 - c. Training of Operating Personnel
 - d. Record Drawings
 - e. Warranty and Guaranty Certificates
 - f. Start-up/test Documents and Commissioning Reports

3.12 FIELD QUALITY CONTROL

- A. Confirm requirements in Division 00, Procurement and Contracting Requirements and Division 01, General Requirements. In absence of specific requirements, comply with individual Division 28, Electronic Safety Sections and the following:
 - 1. Tests:

- a. Conduct tests of equipment and systems to demonstrate compliance with requirements specified. Reference individual Specification Sections for required tests. Document tests and include in Closeout Documents.
- b. During site evaluations by Architect or Engineer, provide appropriate personnel with tools to remove and replace trims, covers, and devices so that proper evaluation of installation can be performed.

3.13 LETTER OF CONFORMANCE

- A. Provide Letter of Conformance, copies of manufacturers' warranties and extended warranties with a statement in letter that electronic safety systems were installed in accordance with manufacturer's recommendations, UL listings and FM Global approvals. Include Letter of Conformance, copies of manufacturers' warranties and extended warranties in operating and maintenance manuals.

END OF SECTION

SECTION 28 3100 - FIRE DETECTION AND ALARM

PART 1 - GENERAL

1.1 SUMMARY

A. Work Included:

1. Fire Alarm Control Units
2. Fire Alarm Transmitters
3. Manual Pull Stations
4. Input Modules
5. Fault Isolation Modules
6. Single/Multiple Station Smoke Alarms
7. Single/Multiple Station Combination Carbon Monoxide and Smoke Alarms
8. Miscellaneous Accessories

B. Scope:

1. Provide a new fire alarm system.
2. Provide a new fire alarm transmitter communication system.
3. Provide new residential unit smoke and carbon monoxide detection and alarm.

C. In addition, provide design for the following as required in these Contract Documents:
Residential Units Smoke and Carbon Monoxide detection and alarm.

D. System Design:

1. Design Criteria: These are Contractor designed systems. Contact AHJ prior to bid to verify systems' requirements. Design systems in compliance with code as interpreted by the AHJ.
2. Design of Fire Alarm System:
 - a. Provide design of the fire alarm system as required by code.
 - b. Fire Alarm Sequence of Operation: Activation of manual fire alarm box, automatic fire detector, or fire extinguishing system causes system to enter "alarm" mode including the following operations:
 - 1) Local English language annunciation of device location, address and condition and audible and visual alarm signal at control panel and remote annunciators.
 - 2) Manual "acknowledge" function at control panel and remote annunciators to silence audible alarm signal, visual signal remains displayed until initiating alarm is cleared.
 - 3) Transmit "alarm" signal to off-premises equipment, i.e., to local fire department or Owner's selected vendor. Provide necessary connections to transmitter.
 - c. Supervisory Sequence of Operation: Fire sprinkler tamper or supervisory pressure switch activation, or duct-mounted smoke detector activation causes system to enter "supervisory" mode including the following operations:
 - 1) Local English language annunciation of device location, address and condition and audible and visual supervisory signal at control panel and remote annunciators.

- 2) Manual "acknowledge" function at control panel and remote annunciators to silence audible supervisory signal, visual signal remains displayed until initiating supervisory is cleared.
- 3) Transmit "supervisory" signal to off-premises equipment.
- d. Trouble Sequence of Operation: System trouble, including single ground or open of supervised circuit, or power or system failure, causes system to enter "trouble" mode including the following operations:
 - 1) Local English language annunciation of device location, address and condition and audible and visual trouble signal at control panel and remote annunciators.
 - 2) Manual "acknowledge" function at control panel and remote annunciators to silence audible trouble signal, visual signal remains displayed until initiating trouble is cleared.
 - 3) Transmit "trouble" signal to off-premises equipment.
3. Design of Fire Alarm Transmitter Communication System: Provide design of the fire alarm transmitter communication system as required by code.
4. Design of Residential Units Smoke and Carbon Monoxide Alarms:
 - a. Provide design of the residential units smoke and carbon monoxide alarm system as required by code.
 - b. Smoke Alarm Sequence of Operation: Smoke alarm operation causes other smoke alarms within the dwelling unit to operate.
 - c. Carbon Monoxide Detector Sequence of Operation:
 - 1) Carbon Monoxide detector operation in dwelling unit causes other carbon monoxide alarms within the dwelling unit to operate.
 - 2) Where the carbon monoxide detector is located in a building common space, the individual detector will activate.

1.2 RELATED SECTIONS

- A. Contents of Division 28, Electronic Safety and Division 01, General Requirements apply to this Section.
- B. Division 26, Electrical requirements apply to this section.

1.3 REFERENCES AND STANDARDS

- A. References and Standards as required by Division 28, Electronic Safety and Division 01, General Requirements.
- B. In addition, meet the following:
 1. NFPA 72, National Fire Alarm and Signaling Code, adopted edition.
 2. NFPA 70, National Electrical Code, adopted edition.

1.4 SUBMITTALS

- A. Submittals as required by Division 28, Electronic Safety and Division 01, General Requirements.
- B. In addition, provide:
 1. Shop drawings to include the following:

- a. Provide system designer NICET certification number or Engineer's signature and seal on shop drawings.
 - b. Identification of system designer and evidence of qualification or certification of designer as required by AHJ.
 - c. Floor plans indicating walls, doors, partitions, room descriptions, device/component locations.
 - d. Ceiling height and ceiling construction details.
 - e. A symbol legend with device catalog number, description, back box size and mounting requirements.
 - f. Detailed riser diagram.
 - g. Device address adjacent to each device symbol. Notification appliance circuit and number adjacent to each notification appliance symbol.
 - h. Point to point wiring indicating the quantity and gauge of the conductors and size of conduit/raceway used.
 - i. Wiring connection diagrams for control equipment, annunciators, power supplies, chargers, initiating devices, notification appliances, components being connected to the system and interfaces to associated equipment.
 - j. Battery calculations for each battery backed fire alarm control unit.
 - k. Voltage drop calculations for each notification appliance circuit, indicating individual appliance current draw, conductor run length and size.
 - l. Complete sequence of operation.
2. Prior to final acceptance, submit a letter confirming that inspections have been completed and system is installed and functioning in accordance with Specifications. Include manufacturer representative's certification of installation and letter of warranty.
 3. Operation and Maintenance Manuals. Provide manuals containing the following:
 - a. Catalog Cut Sheets
 - b. System Components, Initiating Devices and Notification Appliances' Installation Sheets
 - c. Manufacturer's Installation, Operation and Maintenance Manual
 - d. Record Drawings
 - e. Record Drawings on Electronic Storage Media
 - f. One year warranty agreement including parts and labor. Warranty period begins upon date of completion.
 - g. Record of Completion
 - h. Test Reports
 - i. Instruction Chart

1.5 QUALITY ASSURANCE

- A. Quality assurance as required by Division 28, Electronic Safety and Division 01, General Requirements.
- B. In addition, meet City of Arlington, Virginia requirements, ordinances and amendments.

1.6 WARRANTY

- A. Warranty of materials and workmanship as required by Division 28, Electronic Safety and Division 01, General Requirements.

PART 2 - PRODUCTS

2.1 MANUFACTURERS

- A. Fire Alarm Control Units:
 - 1. EST
 - 2. Farenhyt
 - 3. Gamewell-FCI
 - 4. Johnson Controls
 - 5. Notifier
 - 6. Potter
 - 7. Siemens
 - 8. Silent Knight
 - 9. Simplex
 - 10. Or approved equivalent.
- B. Fire Alarm Transmitters:
 - 1. Same manufacturer as fire alarm control equipment.
 - 2. Or approved equivalent.
- C. Manual Pull Stations:
 - 1. Same manufacturer as fire alarm control equipment.
 - 2. No substitutions permitted.
- D. Input Modules:
 - 1. Same manufacturer as fire alarm control equipment.
 - 2. No substitutions permitted.
- E. Fault Isolation Modules:
 - 1. Same manufacturer as fire alarm control equipment.
 - 2. No substitutions permitted.
- F. Single/Multiple Station Smoke Alarms:
 - 1. BRK
 - 2. Gentex
 - 3. Kidde
 - 4. Or approved equivalent.
- G. Single/Multiple Station Combination Carbon Monoxide and Smoke Alarms:
 - 1. BRK
 - 2. Gentex
 - 3. Kidde
 - 4. Or approved equivalent.
- H. Miscellaneous Accessories:
 - 1. Circuit Conductors:
 - a. Allied Wire and Cable
 - b. Belden
 - c. CCI

- d. West Penn Wire
 - e. Or approved equivalent.
 2. Surge Protection:
 - a. Ditek
 - b. Transtector
 - c. Or approved equivalent.
 3. Batteries:
 - a. Same manufacturer as fire alarm control equipment.
 - b. Power-Sonic
 - c. Werker
 - d. Or approved equivalent.
 4. Locks and Keys:
 - a. Same manufacturer as fire alarm control equipment.
 - b. Or approved equivalent.
 5. Document Storage Cabinet:
 - a. Same manufacturer as fire alarm control equipment.
 - b. Meir Products
 - c. Space Age
 - d. Or approved equivalent.
 6. Instruction Charts: Confirm make and model with architect prior to ordering.
- I. Substitutions:
1. For other acceptable manufacturers of specified control units, submit product data showing equivalent features and compliance with Contract Documents.
 2. For substitution of products by manufacturers not listed, submit product data showing features and certification by Contractor that the design will comply with contract documents.
- J. Equipment to be supplied by a certified manufacturer representative.
- ## 2.2 FIRE ALARM CONTROL UNITS
- A. Provide flush mounted units where installed in finished areas; in unfinished areas, surface mounted units are acceptable, unless otherwise noted.
- B. Multiprocessor Based: Configurable as an addressable, point identified system.
- C. Central Processing Unit (CPU):
1. CPU continuously monitors the communications and data processing cycles of microprocessor. CPU failure generates an audible and visual trouble signal on control panel and remote annunciators.
 2. House the CPU in fire alarm cabinet with sufficient space to allow maximum system expansion and to enclose alphanumeric display.
 3. Retain basic life safety software in field programmable non-volatile memory. Provide CPU with capacity of minimum of 50 addressable points.
 4. Equip CPU with software to provide a control-by-event feature, whereby receipt of an alarm point is programmed to operate control points within system. Provide control-by-event actions for life safety functions in programmable non-volatile memory. CPU software programming for control of systems defined in this Section is installed as part of this Section.

- D. System Capabilities:
1. System capable of addressing and operating smoke detectors, manual pull stations, open contact devices and addressable auxiliary control relays on the same communication loop.
 2. System capable of displaying value of each smoke detector, address and condition of fire alarm monitoring points.
- E. Program Software:
1. Field configuration program provides programmable operating instructions for system. Store resident program in non-volatile memory.
 2. Programmed control point activation includes selective control of HVAC, fire door release, elevator recall, elevator shunt trip, and other fire safety and auxiliary functions.
 3. Devices meet criterion specified under materials.
 4. Verification and display of sensitivity of each addressable smoke detector can be read using the operating software. Replace devices with readings outside of allowed value at time of system check out.
- F. Control Panel Display Modules:
1. Provide keyboard display module 80-character backlit LCD. Each alarm/trouble condition appears in English language with description and location of alarm/supervisory/trouble.
 2. Alarm/supervisory/trouble may be acknowledged, silenced and system reset from control panel or remote annunciator(s).
- G. Power Supply: Provide power supply(s), adequate to serve control panel modules, remote annunciators, addressable devices, notification appliances and other connected devices.
- H. Power Requirements:
1. Loss of 120VAC power automatically causes system to transfer to battery power. Indicate battery power operation by yellow lamp and audible annunciation at control panel and remote annunciator panels. Upon return of 120VAC power, unit recharges batteries to full capacity and maintains battery on float charge. Provide trickle charge adequate capacity to maintain battery fully charged with automatic rate charge.
 2. Provide batteries in locking cabinet manufactured for purpose.
- I. Auxiliary Relays: Provide sufficient SPDT auxiliary relay contacts for each function in this portion of the Specifications and for equipment interconnections required under electrical and mechanical specifications.
- J. Auxiliary Switches: Provide auxiliary equipment control switches with labeled status indicating lights for each switch.
- K. System Reset:
1. Key-accessible control function returns system to normal, non-alarm state, if initiating circuits have cleared.
 2. Provide reset on both main fire alarm control panel and remote annunciators.

- L. Lamp Test: Manual "lamp test" function causes the annunciation lamps to illuminate at fire alarm control and remote annunciator panels. Provide "lamp test" function at each annunciator panel.
- M. Addressing: Provide each initiating device with its own discrete address.

2.3 FIRE ALARM TRANSMITTERS

- A. Provide flush mounted units where installed in finished areas; in unfinished areas, surface mounted units are acceptable, unless otherwise noted.
- B. Electrically supervised, capable of transmitting alarm, supervisory and trouble signals over RF, GSM, Cellular, or Ethernet lines to off-premises receiver. Signal transmitter interfaces fully with receiver station of local fire department or Owner's selected vendor.
- C. Verify requirements and provide call sequence and message as directed by Owner and the AHJ.

2.4 MANUAL PULL STATIONS

- A. Provide flush mounted units where installed in finished areas; in unfinished areas, surface mounted units are acceptable, unless otherwise noted.
- B. Semi-flush, red finish, nongrasping operation; maximum pull strength as allowed per ADA criteria.
- C. Stations do not allow closure without keyed reset.

2.5 INPUT MODULES

- A. Signaling line circuit interface module that provides initiating device circuits for connection to contact closure initiating devices.
- B. Module powered from control panel.

2.6 FAULT ISOLATION MODULES

- A. Signaling line circuit interface modules that provide isolation of wire-to-wire shorts on a signaling line circuit with automatic reconnection upon correction of short circuit.
- B. Provide module with status indicator LED.

2.7 SINGLE/MULTIPLE STATION SMOKE ALARMS

- A. 120VAC, direct wired, photoelectric smoke alarm/detector with 9VDC battery backup as an auxiliary power source in the event of an electrical failure. Include 90dB piezo solid-state, non-latching sounder. Temporal 3 evacuation sounding device.
- B. Tandem connection up to 12 units. Three-position test switch.

2.8 SINGLE/MULTIPLE STATION COMBINATION CARBON MONOXIDE AND SMOKE ALARMS

- A. 120VAC photoelectric smoke alarm/detector with 9VDC battery backup as an auxiliary power source in the event of an electrical failure. Commercial grade, electro-chemical carbon monoxide sensor, end-of-sensor life monitoring. Include 90dB piezo solid-state, non-latching sounder. Temporal 3 evacuation sounding device for smoke alarm and Temporal 4 for Carbon Monoxide Alarm.
- B. Tandem connection up to 12 units.

2.9 MISCELLANEOUS ACCESSORIES

- A. Circuit Conductors: Copper or optical fiber; color code and label. Type FPL, FPLR and FPLP as required by NEC. Minimum signaling line circuit and initiating device circuit wire size: AWG18. Minimum notification appliance circuit wire size: AWG14, or as approved by Engineer. Fiber optic cable as required by manufacturer.
- B. Surge Protection: In accordance with IEEE C62.41 B3 combination waveform and NFPA 70; except for optical fiber conductors.
- C. Batteries: Sealed lead acid type. Provide additional cabinet, if required due to space limitations in control panels.
- D. Locks and Keys:
 - 1. Deliver keys to Owner.
 - 2. Provide same standard lock and key for each key operated switch and lockable panel and cabinet; provide five keys of each type.
- E. Document Storage Cabinet:
 - 1. Suitable for as-built drawings, operation and maintenance manual, system data file disk and tools.
 - 2. Constructed from steel with baked enamel finish; size adequate for full size drawings, operation and maintenance manual, spare parts and tools.
- F. Instruction Charts:
 - 1. Printed instruction chart for operators, showing steps to be taken when signal is received (normal, alarm, supervisory and trouble); easily readable from normal operator's station.
 - 2. Frame: Stainless steel or aluminum with polycarbonate or glass cover.
- G. Framed Floor Map:
 - 1. Provide framed floor plan of facility.
 - 2. Frame: Stainless steel or aluminum with polycarbonate or glass cover.

PART 3 - EXECUTION

3.1 GENERAL INSTALLATION REQUIREMENTS

- A. Obtain Architect's approval of locations of devices, appliances and annunciators before installation.

- B. Circuits:
 - 1. Signaling Line Circuits (SLC): Class B
 - 2. Notification Appliance Circuits (NAC): Class B.
- C. Spare Capacity:
 - 1. Notification Appliance Circuits: Minimum 25 percent spare current capacity. Utilize UL maximum current draw values for notification appliances. Maximum 10 percent voltage drop.
 - 2. Signaling Line Circuit: Minimum 25 percent spare capacity.
- D. Primary Power Source: Dedicated branch circuits of facility power distribution system.
 - 1. Secondary: Storage batteries.
 - 2. Capacity: Sufficient to operate fire alarm system under normal supervisory condition for 24 hours and operate alarm signals for five minutes at end of standby period.
- E. Obtain approval of system design from AHJ prior to installation. Do not begin installation without approval from AHJ and submittal review comments from Engineer.
- F. Install in accordance with applicable codes, NFPA 72, NFPA 70 and the Contract Documents.
- G. In accordance with manufacturer's instructions, provide wiring, conduit and outlet boxes required for the erection of a complete system as described in these specifications, as shown on Drawings and as required by AHJ.
- H. Conceal wiring, conduit, boxes and supports where installed in finished areas.
- I. Provide raceway system for cabling concealed in walls and hard ceilings and in locations where cabling is exposed. Where exposed, provide surface raceway in finished areas and surface mounted EMT in non-finished areas.
- J. At junction boxes and termination points, provide identification tags on wires and cables.
- K. Route wiring to avoid blocking access to equipment requiring service, access, or adjustment.
- L. Fire Safety Systems Interfaces:
 - 1. Provide conduit, wiring, boxes and terminations from fire alarm system to monitored components.
 - a. Alarm Inputs: Provide connection in accordance with NFPA 72 for the following systems and components:
 - 1) Fire sprinkler water flow switches.
 - 2) Fire sprinkler dry-pipe alarm pressure switches.
 - 3) Other alarm inputs.
 - b. Supervisory Inputs: Provide connection in accordance with NFPA 72 for the following systems and components:
 - 1) Fire sprinkler water control valve tamper switches.
 - 2) Fire sprinkler dry-pipe system low air pressure switches.
 - 3) Other supervisory inputs.
 - c. Trouble Inputs: Provide connection in accordance with NFPA 72 for the following systems and components:

1) Other trouble inputs.

M. Inspection and Testing for Completion:

1. System testing and commissioning to be performed by a certified manufacturer representative.
2. Perform inspection and testing in accordance with NFPA 72 and requirements of local authorities; document each inspection and test.
3. Provide the services of the installer's supervisor or person with equivalent qualifications to supervise inspection and testing, correction and adjustments.
4. Provide tools, software and supplies required to accomplish inspection and testing.
5. Prepare for testing by ensuring that work is complete and correct; perform preliminary tests as required to test system.
6. Correct defective work, adjust for proper operation and retest until entire system complies with Contract Documents.
7. Notify Owner seven days prior to beginning completion inspections and tests.
8. Notify authorities having jurisdiction and comply with their requirements for scheduling inspections and tests and for observation by their personnel.
9. Diagnostic Period: After successful completion of inspections and tests, operate system in normal mode for at least 14 days without any system or equipment malfunctions.
 - a. Record all system operations and malfunctions.
 - b. If a malfunction occurs, start diagnostic period over after correction of malfunction.
 - c. Owner will provide attendant operator personnel during diagnostic period; schedule training to allow Owner personnel to perform normal duties.
 - d. At end of successful diagnostic period, complete and submit NFPA 72 "Inspection and Testing Form."

N. Owner Personnel Instruction:

1. Provide hands-on instruction to designated Owner personnel, on-site, using operational system.
2. Basic Operation: One-hour sessions for attendant personnel, security officers and engineering staff. Combination of classroom and hands-on initial training; one session pre-closeout.

O. Closeout:

1. Closeout Demonstration:
 - a. Demonstrate proper operation of functions to Owner.
 - b. Be prepared to conduct any of the required tests.
 - c. Have at least one copy of operation and maintenance data, copy of project record drawings, input/output matrix and operator instruction chart(s) available during demonstration.
 - d. Have authorized technical representative of control unit manufacturer present during demonstration.
 - e. Demonstration may be combined with inspection and testing required by AHJ. Notify AHJ in time to schedule demonstration.
 - f. Repeat demonstration until successful.
2. Substantial Completion of the project cannot be achieved until inspection and testing is successful and:
 - a. Specified diagnostic period without malfunction has been completed.
 - b. Approved operating and maintenance data has been delivered.

- c. Spare parts, extra materials and tools have been delivered.
- d. All aspects of operation have been demonstrated to Architect.
- e. Final acceptance of the fire alarm system has been given by authorities having jurisdiction.
- f. Occupancy permit has been granted.

3.2 FIRE ALARM CONTROL UNITS

- A. Reference 3.01, General Installation Requirements.
- B. Install per manufacturer's instructions and recommendations.
- C. Provide control units with 120VAC dedicated circuit per NFPA requirements.
- D. Do not install cabinets or equipment below the battery cabinet. Do not locate battery and charging system cabinets in ceiling space.
- E. Provide instruction charts at each control unit where system operations are performed. Obtain approval from the Architect prior to mounting.
- F. Perform system programming at the fire alarm control panel. Program the system without shutting the system down. Programming is done off line. Update and maintain hard copy and CD-ROM copy of program at the site.
- G. Room Name Labeling: Control unit schedules, programming and labeling for electrical equipment, to use the room names and room numbers that the Architect adopts at the date of substantial completion of construction. This work is to be done at no added cost to the Owner.
- H. Programmable Function Keys: Provide control panel accessible function keys for the notification bypass, fire drill, fire door bypass, elevator control bypass, and supervising station bypass.

3.3 FIRE ALARM TRANSMITTERS

- A. Reference 3.01, General Installation Requirements.
- B. Install per manufacturer's instructions and recommendations.
- C. Provide conduit and wiring for connections to the transmitter as required for fire alarm system off site supervision.

3.4 MANUAL PULL STATIONS

- A. Reference 3.01, General Installation Requirements.
- B. Install per manufacturer's instructions and recommendations.
- C. Provide machine printed address labels on addressable devices. Labels to be visible from the floor without magnification.
- D. Provide protective guard where device is subject to abuse and where required by AHJ.

3.5 INPUT MODULES

- A. Reference 3.01, General Installation Requirements.
- B. Install per manufacturer's instructions and recommendations.
- C. Provide machine printed address labels on addressable devices. Labels to be visible from the floor without magnification.

3.6 FAULT ISOLATION MODULES

- A. Reference 3.01, General Installation Requirements.
- B. Install per manufacturer's instructions and recommendations.
- C. Provide machine printed address labels on addressable devices. Labels to be visible from the floor without magnification.
- D. Provide Fault Isolator Modules for signaling line circuit per code requirements and manufacturer instructions.

3.7 SINGLE/MULTIPLE STATION SMOKE ALARMS

- A. Reference 3.01, General Installation Requirements.
- B. Install per manufacturer's instructions and recommendations.
- C. Provide machine printed address labels on addressable devices. Labels to be visible from the floor without magnification.
- D. Provide smoke alarms with 120VAC power from building power systems.

3.8 SINGLE/MULTIPLE STATION COMBINATION CARBON MONOXIDE AND SMOKE ALARMS

- A. Reference 3.01, General Installation Requirements.
- B. Install per manufacturer's instructions and recommendations.
- C. Provide machine printed address labels on addressable devices. Labels to be visible from the floor without magnification.
- D. Provide carbon monoxide detectors and smoke alarms with 120VAC power from building power systems.

3.9 MISCELLANEOUS ACCESSORIES

- A. Reference 3.01, General Installation Requirements.
- B. Install per manufacturer's instructions and recommendations.

- C. Document Storage Cabinet: Provide document storage cabinet adjacent to fire alarm control panel.
- D. Instruction Charts: Install chart adjacent to fire control unit.
- E. Framed Floor Map: Provide framed floor plan of facility adjacent to the annunciator panel identifying room names/numbers, device/addresses or fire zone number and description as utilized on the annunciator panel, as required by local AHJ. Check with the local fire department for size and approved mounting location.

END OF SECTION

SECTION 311000 - SITE CLEARING

PART 1 - GENERAL

1.1 SUMMARY

A. Section Includes:

1. Protecting existing vegetation to remain.
2. Removing existing vegetation.
3. Clearing and grubbing.
4. Stripping and stockpiling topsoil.
5. Removing above- and below-grade site improvements.
6. Disconnecting, capping, or sealing site utilities.
7. Temporary erosion and sedimentation control.

1.2 PREINSTALLATION MEETINGS

- A. Preinstallation Conference: Conduct conference at Project site.

1.3 MATERIAL OWNERSHIP

- A. Except for materials indicated to be stockpiled or otherwise remain Owner's property, cleared materials shall become Contractor's property and shall be removed from Project site.

1.4 FIELD CONDITIONS

- A. Traffic: Minimize interference with adjoining roads, streets, walks, and other adjacent occupied or used facilities during site-clearing operations.
1. Do not close or obstruct streets, walks, or other adjacent occupied or used facilities without permission from Owner and authorities having jurisdiction.
 2. Provide alternate routes around closed or obstructed trafficways if required by Owner or authorities having jurisdiction.
- B. Utility Locator Service: Notify utility locator service for area where Project is located before site clearing.
- C. Do not commence site clearing operations until temporary erosion- and sedimentation-control and plant-protection measures are in place.
- D. Tree- and Plant-Protection Zones: Protect according to requirements in Section 015639 "Temporary Tree and Plant Protection."

PART 2 - PRODUCTS

2.1 MATERIALS

- A. Satisfactory Soil Material: Requirements for satisfactory soil material are specified in Section 312000 "Earth Moving."
 - 1. Obtain approved borrow soil material off-site when satisfactory soil material is not available on-site.

PART 3 - EXECUTION

3.1 PREPARATION

- A. Protect and maintain benchmarks and survey control points from disturbance during construction.
- B. Verify that trees, shrubs, and other vegetation to remain or to be relocated have been flagged and that protection zones have been identified and enclosed.
- C. Protect existing site improvements to remain from damage during construction.
 - 1. Restore damaged improvements to their original condition, as acceptable to Owner.

3.2 TEMPORARY EROSION AND SEDIMENTATION CONTROL

- A. Provide temporary erosion- and sedimentation-control measures to prevent soil erosion and discharge of soil-bearing water runoff or airborne dust to adjacent properties and walkways, according to erosion- and sedimentation-control Drawings and requirements of authorities having jurisdiction.
- B. Verify that flows of water redirected from construction areas or generated by construction activity do not enter or cross protection zones.
- C. Inspect, maintain, and repair erosion- and sedimentation-control measures during construction until permanent vegetation has been established.
- D. Remove erosion and sedimentation controls, and restore and stabilize areas disturbed during removal.

3.3 TREE AND PLANT PROTECTION

- A. Protect trees and plants remaining on-site.
- B. Repair or replace trees, shrubs, and other vegetation indicated to remain or be relocated that are damaged by construction operations.

3.4 EXISTING UTILITIES

- A. Locate, identify, disconnect, and seal or cap utilities indicated to be removed or abandoned in place.
 - 1. Arrange with utility companies to shut off indicated utilities.
- B. Interrupting Existing Utilities: Do not interrupt utilities serving facilities occupied by Owner or others, unless permitted under the following conditions and then only after arranging to provide temporary utility services according to requirements indicated:
 - 1. Notify Owner not less than two days in advance of proposed utility interruptions.
 - 2. Do not proceed with utility interruptions without Architect's written permission.
- C. Removal of underground utilities is included in applicable fire suppression, plumbing, HVAC, electrical, communications, electronic safety and security, and utilities sections and on Site - Civil Drawings..

3.5 CLEARING AND GRUBBING

- A. Remove obstructions, trees, shrubs, and other vegetation to permit installation of new construction.
 - 1. Grind down stumps and remove roots larger than 3 inches (75 mm) in diameter, obstructions, and debris to a depth of 18 inches (450 mm) below exposed subgrade.
 - 2. Use only hand methods or air spade for grubbing within protection zones.
- B. Fill depressions caused by clearing and grubbing operations with satisfactory soil material unless further excavation or earthwork is indicated.
 - 1. Place fill material in horizontal layers not exceeding a loose depth of 8 inches (200 mm), and compact each layer to a density equal to adjacent original ground.

3.6 TOPSOIL STRIPPING

- A. Remove sod and grass before stripping topsoil.
- B. Strip topsoil to depth of 6 inches (150 mm) in a manner to prevent intermingling with underlying subsoil or other waste materials.
- C. Stockpile topsoil away from edge of excavations without intermixing with subsoil or other materials. Grade and shape stockpiles to drain surface water. Cover to prevent windblown dust and erosion by water.

3.7 SITE IMPROVEMENTS

- A. Remove existing above- and below-grade improvements as indicated and necessary to facilitate new construction.

3.8 DISPOSAL OF SURPLUS AND WASTE MATERIALS

- A. Remove surplus soil material, unsuitable topsoil, obstructions, demolished materials, and waste materials including trash and debris, and legally dispose of them off Owner's property.
- B. Separate recyclable materials produced during site clearing from other nonrecyclable materials. Store or stockpile without intermixing with other materials, and transport them to recycling facilities. Do not interfere with other Project work.

END OF SECTION 311000

SECTION 312000 - EARTH MOVING

PART 1 - GENERAL

1.1 SUMMARY

A. Section Includes:

1. Excavating and filling for rough grading the Site.
2. Preparing subgrades for slabs-on-grade, walks, pavements, turf and grasses, and plants.
3. Excavating and backfilling for buildings and structures.
4. Drainage course for concrete slabs-on-grade.
5. Subbase course for concrete walks and pavements.
6. Subbase course and base course for asphalt paving.
7. Excavating and backfilling trenches for utilities and pits for buried utility structures.

1.2 DEFINITIONS

A. Backfill: Soil material used to fill an excavation.

1. Initial Backfill: Backfill placed beside and over pipe in a trench, including haunches to support sides of pipe.
2. Final Backfill: Backfill placed over initial backfill to fill a trench.

B. Base Course: Aggregate layer placed between the subbase course and hot-mix asphalt paving.

C. Bedding Course: Aggregate layer placed over the excavated subgrade in a trench before laying pipe.

D. Borrow Soil: Satisfactory soil imported from off-site for use as fill or backfill.

E. Drainage Course: Aggregate layer supporting the slab-on-grade that also minimizes upward capillary flow of pore water.

F. Excavation: Removal of material encountered above subgrade elevations and to lines and dimensions indicated.

1. Authorized Additional Excavation: Excavation below subgrade elevations or beyond indicated lines and dimensions as directed by Architect. Authorized additional excavation and replacement material will be paid for according to Contract provisions for changes in the Work.
2. Unauthorized Excavation: Excavation below subgrade elevations or beyond indicated lines and dimensions without direction by Architect. Unauthorized excavation, as well as remedial work directed by Architect, shall be without additional compensation.

G. Fill: Soil materials used to raise existing grades.

- H. Structures: Buildings, footings, foundations, retaining walls, slabs, tanks, curbs, mechanical and electrical appurtenances, or other man-made stationary features constructed above or below the ground surface.
- I. Subbase Course: Aggregate layer placed between the subgrade and base course for hot-mix asphalt pavement, or aggregate layer placed between the subgrade and a cement concrete pavement or a cement concrete or hot-mix asphalt walk.
- J. Subgrade: Uppermost surface of an excavation or the top surface of a fill or backfill immediately below subbase, drainage fill, drainage course, or topsoil materials.
- K. Utilities: On-site underground pipes, conduits, ducts, and cables as well as underground services within buildings.

1.3 PREINSTALLATION MEETINGS

- A. Preinstallation Conference: Conduct preexcavation conference at Project site.

1.4 INFORMATIONAL SUBMITTALS

- A. Material test reports.

1.5 FIELD CONDITIONS

- A. Utility Locator Service: Notify utility locator service for area where Project is located before beginning earth-moving operations.
- B. Do not commence earth-moving operations until plant-protection measures are in place.

PART 2 - PRODUCTS

2.1 SOIL MATERIALS

- A. General: Provide borrow soil materials when sufficient satisfactory soil materials are not available from excavations.
- B. Satisfactory Soils: Soil Classification Groups GW, GP, GM, SW, SP, and SM according to ASTM D 2487, or a combination of these groups; free of rock or gravel larger than **3 inches (75 mm)** in any dimension, debris, waste, frozen materials, vegetation, and other deleterious matter.
- C. Unsatisfactory Soils: Soil Classification Groups GC, SC, CL, ML, OL, CH, MH, OH, and PT according to ASTM D 2487, or a combination of these groups.
 - 1. Unsatisfactory soils also include satisfactory soils not maintained within 2 percent of optimum moisture content at time of compaction.

- D. Subbase Material: Naturally or artificially graded mixture of natural or crushed gravel, crushed stone, and natural or crushed sand; ASTM D 2940/D 2940M; with at least 90 percent passing a 1-1/2-inch (37.5-mm) sieve and not more than 12 percent passing a No. 200 (0.075-mm) sieve.
- E. Base Course: Naturally or artificially graded mixture of natural or crushed gravel, crushed stone, and natural or crushed sand; ASTM D 294/D 2940M 0; with at least 95 percent passing a 1-1/2-inch (37.5-mm) sieve and not more than 8 percent passing a No. 200 (0.075-mm) sieve.
- F. Engineered Fill: Naturally or artificially graded mixture of natural or crushed gravel, crushed stone, and natural or crushed sand; ASTM D 2940/D 2940M; with at least 90 percent passing a 1-1/2-inch (37.5-mm) sieve and not more than 12 percent passing a No. 200 (0.075-mm) sieve.
- G. Bedding Course: Naturally or artificially graded mixture of natural or crushed gravel, crushed stone, and natural or crushed sand; ASTM D 2940/D 2940M; except with 100 percent passing a 1-inch (25-mm) sieve and not more than 8 percent passing a No. 200 (0.075-mm) sieve.
- H. Drainage Course: Narrowly graded mixture of crushed stone, or crushed or uncrushed gravel; ASTM D 448; coarse-aggregate grading Size 57; with 100 percent passing a 1-1/2-inch (37.5-mm) sieve and zero to 5 percent passing a No. 8 (2.36-mm) sieve.

2.2 ACCESSORIES

- A. Warning Tape: Acid- and alkali-resistant, polyethylene film warning tape manufactured for marking and identifying underground utilities, 6 inches (150 mm) wide and 4 mils (0.1 mm) thick, continuously inscribed with a description of the utility; colored to comply with local practice or requirements of authorities having jurisdiction.
- B. Detectable Warning Tape: Acid- and alkali-resistant, polyethylene film warning tape manufactured for marking and identifying underground utilities, a minimum of 6 inches (150 mm) wide and 4 mils (0.1 mm) thick, continuously inscribed with a description of the utility, with metallic core encased in a protective jacket for corrosion protection, detectable by metal detector when tape is buried up to 30 inches (750 mm) deep; colored to comply with local practice or requirements of authorities having jurisdiction.

PART 3 - EXECUTION

3.1 PREPARATION

- A. Protect structures, utilities, sidewalks, pavements, and other facilities from damage caused by settlement, lateral movement, undermining, washout, and other hazards created by earth-moving operations.
- B. Protect and maintain erosion and sedimentation controls during earth-moving operations.
- C. Protect subgrades and foundation soils from freezing temperatures and frost. Remove temporary protection before placing subsequent materials.

3.2 EXCAVATION, GENERAL

- A. Unclassified Excavation: Excavate to subgrade elevations regardless of the character of surface and subsurface conditions encountered. Unclassified excavated materials may include rock, soil materials, and obstructions. No changes in the Contract Sum or the Contract Time will be authorized for rock excavation or removal of obstructions.
 - 1. If excavated materials intended for fill and backfill include unsatisfactory soil materials and rock, replace with satisfactory soil materials.

3.3 EXCAVATION FOR STRUCTURES

- A. Excavate to indicated elevations and dimensions within a tolerance of plus or minus **1 inch (25 mm)**. If applicable, extend excavations a sufficient distance from structures for placing and removing concrete formwork, for installing services and other construction, and for inspections.
 - 1. Excavations for Footings and Foundations: Do not disturb bottom of excavation. Excavate by hand to final grade just before placing concrete reinforcement. Trim bottoms to required lines and grades to leave solid base to receive other work.
 - 2. Excavation for Underground Tanks, Basins, and Mechanical or Electrical Utility Structures: Excavate to elevations and dimensions indicated within a tolerance of plus or minus 1 inch (25 mm). Do not disturb bottom of excavations intended as bearing surfaces.
- B. Excavations at Edges of Tree- and Plant-Protection Zones:
 - 1. Excavate by hand or with an air spade to indicated lines, cross sections, elevations, and subgrades. If excavating by hand, use narrow-tine spading forks to comb soil and expose roots. Do not break, tear, or chop exposed roots. Do not use mechanical equipment that rips, tears, or pulls roots.

3.4 EXCAVATION FOR WALKS AND PAVEMENTS

- A. Excavate surfaces under walks and pavements to indicated lines, cross sections, elevations, and subgrades.

3.5 EXCAVATION FOR UTILITY TRENCHES

- A. Excavate trenches to indicated gradients, lines, depths, and elevations.
- B. Excavate trenches to uniform widths to provide the following clearance on each side of pipe or conduit. Excavate trench walls vertically from trench bottom to 12 inches (300 mm) higher than top of pipe or conduit unless otherwise indicated.
 - 1. Clearance: 12 inches (300 mm) each side of pipe or conduit.

- C. Trench Bottoms: Excavate and shape trench bottoms to provide uniform bearing and support of pipes and conduit. Shape subgrade to provide continuous support for bells, joints, and barrels of pipes and for joints, fittings, and bodies of conduits. Remove projecting stones and sharp objects along trench subgrade.
 - 1. Excavate trenches 6 inches (150 mm) deeper than elevation required in rock or other unyielding bearing material to allow for bedding course.
- D. Trenches in Tree- and Plant-Protection Zones:
 - 1. Hand-excavate to indicated lines, cross sections, elevations, and subgrades. Use narrow-tine spading forks to comb soil and expose roots. Do not break, tear, or chop exposed roots. Do not use mechanical equipment that rips, tears, or pulls roots.
 - 2. Do not cut main lateral roots or taproots; cut only smaller roots that interfere with installation of utilities.

3.6 SUBGRADE INSPECTION

- A. Proof-roll subgrade below the building slabs and pavements with a pneumatic-tired dump truck to identify soft pockets and areas of excess yielding. Do not proof-roll wet or saturated subgrades.
- B. Reconstruct subgrades damaged by freezing temperatures, frost, rain, accumulated water, or construction activities, as directed by Architect, without additional compensation.

3.7 UNAUTHORIZED EXCAVATION

- A. Fill unauthorized excavation under foundations or wall footings by extending bottom elevation of concrete foundation or footing to excavation bottom, without altering top elevation. Lean concrete fill, with 28-day compressive strength of 2500 psi (17.2 MPa), may be used when approved by Architect.
 - 1. Fill unauthorized excavations under other construction, pipe, or conduit as directed by Architect.

3.8 STORAGE OF SOIL MATERIALS

- A. Stockpile borrow soil materials and excavated satisfactory soil materials without intermixing. Place, grade, and shape stockpiles to drain surface water. Cover to prevent windblown dust.
 - 1. Stockpile soil materials away from edge of excavations. Do not store within drip line of remaining trees.

3.9 UTILITY TRENCH BACKFILL

- A. Place backfill on subgrades free of mud, frost, snow, or ice.

- B. Place and compact bedding course on trench bottoms and where indicated. Shape bedding course to provide continuous support for bells, joints, and barrels of pipes and for joints, fittings, and bodies of conduits.
- C. Trenches under Footings: Backfill trenches excavated under footings and within 18 inches (450 mm) of bottom of footings with satisfactory soil; fill with concrete to elevation of bottom of footings. Concrete is specified in Section 033000 "Cast-in-Place Concrete."
- D. Trenches under Roadways: Provide 4-inch- (100-mm-) thick, concrete-base slab support for piping or conduit less than 30 inches (750 mm) below surface of roadways. After installing and testing, completely encase piping or conduit in a minimum of 4 inches (100 mm) of concrete before backfilling or placing roadway subbase course. Concrete is specified in Section 033000 "Cast-in-Place Concrete."
- E. Initial Backfill: Place and compact initial backfill of subbase material, free of particles larger than 1 inch (25 mm) in any dimension, to a height of 12 inches (300 mm) over the pipe or conduit.
 - 1. Carefully compact initial backfill under pipe haunches and compact evenly up on both sides and along the full length of piping or conduit to avoid damage or displacement of piping or conduit. Coordinate backfilling with utilities testing.
- F. Final Backfill: Place and compact final backfill of satisfactory soil to final subgrade elevation.
- G. Warning Tape: Install warning tape directly above utilities, 12 inches (300 mm) below finished grade, except 6 inches (150 mm) below subgrade under pavements and slabs.

3.10 SOIL FILL

- A. Plow, scarify, bench, or break up sloped surfaces steeper than 1 vertical to 4 horizontal so fill material will bond with existing material.
- B. Place and compact fill material in layers to required elevations as follows:
 - 1. Under grass and planted areas, use satisfactory soil material.
 - 2. Under walks and pavements, use satisfactory soil material.
 - 3. Under steps and ramps, use engineered fill.
 - 4. Under building slabs, use engineered fill.
 - 5. Under footings and foundations, use engineered fill.

3.11 SOIL MOISTURE CONTROL

- A. Uniformly moisten or aerate subgrade and each subsequent fill or backfill soil layer before compaction to within 2 percent of optimum moisture content.
 - 1. Do not place backfill or fill soil material on surfaces that are muddy, frozen, or contain frost or ice.

2. Remove and replace, or scarify and air dry, otherwise satisfactory soil material that exceeds optimum moisture content by 2 percent and is too wet to compact to specified dry unit weight.

3.12 COMPACTION OF SOIL BACKFILLS AND FILLS

- A. Place backfill and fill soil materials in layers not more than 8 inches (200 mm) in loose depth for material compacted by heavy compaction equipment and not more than 4 inches (100 mm) in loose depth for material compacted by hand-operated tampers.
- B. Place backfill and fill soil materials evenly on all sides of structures to required elevations and uniformly along the full length of each structure.
- C. Compact soil materials to not less than the following percentages of maximum dry unit weight according to ASTM D 1557:
 1. Under structures, building slabs, steps, and pavements, scarify and recompact top 12 inches (300 mm) of existing subgrade and each layer of backfill or fill soil material at 95 percent.
 2. Under walkways, scarify and recompact top 6 inches (150 mm) below subgrade and compact each layer of backfill or fill soil material at 92 percent.
 3. Under turf or unpaved areas, scarify and recompact top 6 inches (150 mm) below subgrade and compact each layer of backfill or fill soil material at 85 percent.
 4. For utility trenches, compact each layer of initial and final backfill soil material at 90 percent.

3.13 GRADING

- A. General: Uniformly grade areas to a smooth surface, free of irregular surface changes. Comply with compaction requirements and grade to cross sections, lines, and elevations indicated.
- B. Site Rough Grading: Slope grades to direct water away from buildings and to prevent ponding. Finish subgrades to elevations required to achieve indicated finish elevations, within the following subgrade tolerances:
 1. Turf or Unpaved Areas: Plus or minus 1 inch (25 mm).
 2. Walks: Plus or minus 3/4 inch (19 mm).
 3. Pavements: Plus or minus 1/2 inch (13 mm).
- C. Grading inside Building Lines: Finish subgrade to a tolerance of 1/2 inch (13 mm) when tested with a 10-foot (3-m) straightedge.

3.14 SUBBASE AND BASE COURSES UNDER PAVEMENTS AND WALKS

- A. Place subbase course and base course on subgrades free of mud, frost, snow, or ice.

- B. On prepared subgrade, place subbase course and base course under pavements and walks as follows:
1. Shape subbase course and base course to required crown elevations and cross-slope grades.
 2. Place subbase course and base course that exceeds 6 inches (150 mm) in compacted thickness in layers of equal thickness, with no compacted layer more than 6 inches (150 mm) thick or less than 3 inches (75 mm) thick.
 3. Compact subbase course and base course at optimum moisture content to required grades, lines, cross sections, and thickness to not less than 95 percent of maximum dry unit weight according to ASTM D 1557.

3.15 DRAINAGE COURSE UNDER CONCRETE SLABS-ON-GRADE

- A. Place drainage course on subgrades free of mud, frost, snow, or ice.
- B. On prepared subgrade, place and compact drainage course under cast-in-place concrete slabs-on-grade as follows:
1. Place drainage course that exceeds 6 inches (150 mm) in compacted thickness in layers of equal thickness, with no compacted layer more than 6 inches (150 mm) thick or less than 3 inches (75 mm) thick.
 2. Compact each layer of drainage course to required cross sections and thicknesses to not less than 95 percent of maximum dry unit weight according to ASTM D 698.

3.16 FIELD QUALITY CONTROL

- A. Special Inspections: Owner will engage a qualified special inspector to perform inspections:
- B. Testing Agency: Owner will engage a qualified geotechnical engineering testing agency to perform tests and inspections.
- C. Allow testing agency to inspect and test subgrades and each fill or backfill layer. Proceed with subsequent earth moving only after test results for previously completed work comply with requirements.
- D. Footing Subgrade: At footing subgrades, at least one test of each soil stratum will be performed to verify design bearing capacities. Subsequent verification and approval of other footing subgrades may be based on a visual comparison of subgrade with tested subgrade when approved by Architect.
- E. When testing agency reports that subgrades, fills, or backfills have not achieved degree of compaction specified, scarify and moisten or aerate, or remove and replace soil materials to depth required; recompact and retest until specified compaction is obtained.

3.17 PROTECTION

- A. Protecting Graded Areas: Protect newly graded areas from traffic, freezing, and erosion. Keep free of trash and debris.
- B. Repair and reestablish grades to specified tolerances where completed or partially completed surfaces become eroded, rutted, settled, or where they lose compaction due to subsequent construction operations or weather conditions.
- C. Where settling occurs before Project correction period elapses, remove finished surfacing, backfill with additional soil material, compact, and reconstruct surfacing.
 - 1. Restore appearance, quality, and condition of finished surfacing to match adjacent work, and eliminate evidence of restoration to greatest extent possible.

3.18 DISPOSAL OF SURPLUS AND WASTE MATERIALS

- A. Remove surplus satisfactory soil and waste materials, including unsatisfactory soil, trash, and debris, and legally dispose of them off Owner's property.

END OF SECTION 312000

THIS PAGE INTENSIONALLY LEFT BLANK

SECTION 313116 - TERMITE CONTROL

PART 1 - GENERAL

1.1 SUMMARY

A. Section Includes:

1. Soil treatment.

1.2 ACTION SUBMITTALS

- A. Product Data: For each type of product. Include the EPA-Registered Label for termiticide products.

1.3 INFORMATIONAL SUBMITTALS

- A. Product certificates.

- B. Soil Treatment Application Report: Include the following:

1. Date and time of application.
2. Moisture content of soil before application.
3. Termiticide brand name and manufacturer.
4. Quantity of undiluted termiticide used.
5. Dilutions, methods, volumes used, and rates of application.
6. Areas of application.
7. Water source for application.

1.4 QUALITY ASSURANCE

- A. Installer Qualifications: A specialist who is licensed according to regulations of authorities having jurisdiction to apply termite control treatment and products in jurisdiction where Project is located and who employs workers trained and approved by manufacturer to install manufacturer's products.

1.5 WARRANTY

- A. Soil Treatment Special Warranty: Manufacturer's standard form, signed by Applicator and Contractor, certifying that termite control work consisting of applied soil termiticide treatment will prevent infestation of subterranean termites. If subterranean termite activity or damage is discovered during warranty period, re-treat soil and repair or replace damage caused by termite infestation.

1. Warranty Period: Five years from date of Substantial Completion.

PART 2 - PRODUCTS

2.1 SOIL TREATMENT

- A. Termiticide: EPA-Registered termiticide acceptable to authorities having jurisdiction, in an aqueous solution formulated to prevent termite infestation.
 1. Service Life of Treatment: Soil treatment termiticide that is effective for not less than five years against infestation of subterranean termites.

PART 3 - EXECUTION

3.1 PREPARATION

- A. Remove extraneous sources of wood cellulose and other edible materials, such as wood debris, tree stumps and roots, stakes, formwork, and construction waste wood from soil within and around foundations.
- B. Soil Treatment Preparation: Remove foreign matter and impermeable soil materials that could decrease treatment effectiveness on areas to be treated.

3.2 APPLYING SOIL TREATMENT

- A. Application: Mix soil treatment termiticide solution to a uniform consistency. Distribute treatment uniformly. Apply treatment at the product's EPA-Registered Label volume and rate for maximum specified concentration of termiticide to the following so that a continuous horizontal and vertical termiticidal barrier or treated zone is established around and under building construction.
 1. Slabs-on-Grade and Basement Slabs: Under ground-supported slab construction, including footings, building slabs, and attached slabs as an overall treatment. Treat soil materials before concrete footings and slabs are placed.
 2. Foundations: Soil adjacent to and along the entire inside perimeter of foundation walls; along both sides of interior partition walls; around plumbing pipes and electric conduit penetrating the slab; around interior column footers, piers, and chimney bases; and along the entire outside perimeter, from grade to bottom of footing.
 3. Crawlspace: Soil under and adjacent to foundations. Treat adjacent areas, including around entrance platform, porches, and equipment bases. Apply overall treatment only where attached concrete platform and porches are on fill or ground.
 4. Masonry: Treat voids.
 5. Penetrations: At expansion joints, control joints, and areas where slabs and below-grade walls will be penetrated.

- B. Post warning signs in areas of application.
- C. Reapply soil treatment solution to areas disturbed by subsequent excavation, grading, landscaping, or other construction activities following application.

END OF SECTION 313116

THIS PAGE INTENSIONALLY LEFT BLANK

SECTION 321316 - DECORATIVE CONCRETE PAVING

PART 1 - GENERAL

1.1 SUMMARY

- A. Section includes colored, stamped concrete paving.

1.2 PREINSTALLATION MEETINGS

- A. Preinstallation Conference: Conduct conference at Project site.

1.3 ACTION SUBMITTALS

- A. Product Data: For each type of product.
- B. Samples: For each type of exposed color, pattern, or texture indicated.

1.4 QUALITY ASSURANCE

- A. Installer Qualifications: An employer of workers trained and approved by manufacturer of decorative concrete paving systems.
- B. Ready-Mix-Concrete Manufacturer Qualifications: A firm experienced in manufacturing ready-mixed concrete products and that complies with ASTM C94/C94M requirements for production facilities and equipment.
- C. Mockups: Build mockups to verify selections made under Sample submittals and to demonstrate aesthetic effects and set quality standards for materials and execution.
 - 1. Build mockups of each decorative concrete paving in the permanent locations and approximately 72 inches (1830 mm) by 72 inches (1830 mm) in size.
 - 2. Approval of mockups does not constitute approval of deviations from the Contract Documents contained in mockups unless Architect specifically approves such deviations in writing.
 - 3. Subject to compliance with requirements, approved mockups may become part of the completed Work if undisturbed at time of Substantial Completion.

PART 2 - PRODUCTS

2.1 MANUFACTURERS

- A. Subject to compliance with performance requirements, provide concrete color pigment and stamping tool products by the following manufacturer:
1. Sika Corporation, Sika Scofield Sales Office, Douglasville, GA, 800-800-9900, www.scofield.com.
 2. Stamping Tool: Provide LITHOTEX Pavecrafters Concrete Patterns and Textures. Refer to Exterior Finish Materials schedule, Drawing Sheet #A300.
 3. Concrete Pigment: Provide LITHOCHROME products and Scofield cure and seal. Refer to Exterior Finish Materials schedule, Drawing Sheet #A300.

2.2 CONCRETE, GENERAL

- A. ACI Publications: Comply with ACI 301 (ACI 301M).

2.3 FORMS

- A. Form Materials: Plywood, metal, metal-framed plywood, or other approved panel-type materials to provide full-depth, continuous, straight, and smooth exposed surfaces.

2.4 STEEL REINFORCEMENT

- A. Plain-Steel Welded-Wire Reinforcement: ASTM A1064/A1064M, fabricated from as-drawn steel wire into flat sheets.
- B. Reinforcing Bars: ASTM A615/A615M, Grade 60 (Grade 420); deformed.
- C. Steel Bar Mats: ASTM A184/A184M; with ASTM A615/A615M, Grade 60 (Grade 420) deformed bars; assembled with clips.
- D. Bar Supports: Bolsters, chairs, spacers, and other devices for spacing, supporting, and fastening reinforcing bars, welded-wire reinforcement, and dowels in place. Manufacture bar supports according to CRSI's "Manual of Standard Practice" from steel wire, plastic, or precast concrete of greater compressive strength than concrete specified, and as follows:

2.5 CONCRETE MATERIALS

- A. Cementitious Materials:
1. Portland Cement: ASTM C150/C150M, white portland cement Type I/II.
- B. Normal-Weight Aggregates: ASTM C33/C33M, uniformly graded. Provide aggregates from a single source.

1. Maximum Coarse-Aggregate Size: 3/4 inch (19 mm) nominal.
2. Fine Aggregate: Free of materials with deleterious reactivity to alkali in cement.

C. Air-Entraining Admixture: ASTM C260/C260M.

D. Chemical Admixtures: Admixtures certified by manufacturer to be compatible with other admixtures and to contain not more than 0.1 percent water-soluble chloride ions by mass of cementitious material.

E. Water: Potable and complying with ASTM C94/C94M.

2.6 RELATED MATERIALS

A. Joint Fillers: ASTM D1752, cork or self-expanding cork in preformed strips.

B. Polyethylene Film: ASTM D4397, 1 mil (0.025 mm) thick, clear.

2.7 CONCRETE MIXTURES

A. Prepare design mixtures, proportioned according to ACI 301 (ACI 301M).

B. Add air-entraining admixture at manufacturer's prescribed rate to result in normal-weight concrete at point of placement having an air content as follows:

1. Air Content: **5-1/2** percent plus or minus 1.5 percent.

C. Chemical Admixtures: Use admixtures according to manufacturer's written instructions.

D. Color Pigment: Add color pigment to concrete mixture according to manufacturer's written instructions and to result in hardened concrete color consistent with approved mockup.

E. Concrete Mixtures: Normal-weight concrete.

1. Compressive Strength (28 Days): 3000 psi (20.7 MPa).
2. Maximum W/C Ratio at Point of Placement: 0.45.
3. Slump Limit: 4-1/2 inches (112.5 mm), plus or minus 1 inch (25 mm).

2.8 CONCRETE MIXING

A. Ready-Mixed Concrete: Measure, batch, and mix concrete materials and concrete according to ASTM C94/C94M. Furnish batch certificates for each batch discharged and used in the Work.

PART 3 - EXECUTION

3.1 EXAMINATION

- A. Proof-roll prepared subbase surface below decorative concrete paving to identify soft pockets and areas of excess yielding.

3.2 PREPARATION

- A. Remove loose material from compacted subbase surface immediately before placing concrete.

3.3 EDGE FORMS AND SCREED CONSTRUCTION

- A. Set, brace, and secure edge forms, bulkheads, and intermediate screed guides to required lines, grades, and elevations. Install forms to allow continuous progress of work and so forms can remain in place at least 24 hours after concrete placement.

3.4 STEEL REINFORCEMENT INSTALLATION

- A. Comply with CRSI's "Manual of Standard Practice" for fabricating, placing, and supporting reinforcement.

3.5 JOINTS

- A. General: Form construction, isolation, and contraction joints and tool edges true to line, with faces perpendicular to surface plane of concrete. Construct transverse joints at right angles to centerline unless otherwise indicated.
- B. Construction Joints: Set construction joints at side and end terminations of paving and at locations where paving operations are stopped for more than one-half hour unless paving terminates at isolation joints.
- C. Isolation Joints: Form isolation joints of preformed joint-filler strips abutting concrete curbs, catch basins, manholes, inlets, structures, walks, other fixed objects, and where indicated.
- D. Contraction Joints: Form weakened-plane contraction joints, sectioning concrete into areas as indicated. Construct contraction joints for a depth equal to at least one-fourth of the concrete thickness.
- E. Edging: After initial floating, tool edges of paving, gutters, curbs, and joints in concrete with an edging tool to a 1/4-inch (6-mm) radius. Repeat tooling of edges after applying surface finishes. Eliminate edging-tool marks on concrete surfaces.

3.6 CONCRETE PLACEMENT

- A. Moisten subbase to provide a uniform dampened condition at time concrete is placed. Do not place concrete around manholes or other structures until they are at required finish elevation and alignment.
- B. Comply with ACI 301 (ACI 301M) requirements for measuring, mixing, transporting, and placing concrete.
- C. Deposit and spread concrete in a continuous operation between transverse joints. Do not push or drag concrete into place or use vibrators to move concrete into place.
- D. Screed paving surface with a straightedge and strike off.
- E. Commence initial floating using bull floats or darbies to impart an open-textured and uniform surface plane before excess moisture or bleedwater appears on the surface. Do not further disturb concrete surfaces before beginning finishing operations or spreading surface treatments.

3.7 FLOAT FINISHING

- A. General: Do not add water to concrete surfaces during finishing operations.
- B. Float Finish: Begin the second floating operation when bleedwater sheen has disappeared and concrete surface has stiffened sufficiently to permit operations. Float surface with power-driven floats or by hand floating if area is small or inaccessible to power units. Finish surfaces to true planes. Cut down high spots and fill low spots. Refloat surface immediately to uniform granular texture.

3.8 STAMPING

- A. Tool Stamping: After floating and while concrete is plastic, apply mat-stamped finish in accordance with manufacturer's written requirements.

3.9 CONCRETE PROTECTION AND CURING

- A. General: Protect freshly placed concrete from premature drying and excessive cold or hot temperatures.
- B. Comply with ACI 306.1 for cold-weather protection.
- C. Begin curing after finishing concrete but not before free water has disappeared from concrete surface.
- D. Curing and Sealing Compound: Apply immediately after final finishing. Apply uniformly in continuous operation by power spray according to manufacturer's written instructions. Recoat areas subjected to heavy rainfall within three hours after initial application. Maintain continuity of coating, and repair damage during curing period.

3.10 PAVING TOLERANCES

- A. Comply with tolerances in ACI 117 (ACI 117M).

3.11 REPAIR AND PROTECTION

- A. Remove and replace decorative concrete paving that is broken or damaged or does not comply with requirements in this Section. Remove work in complete sections from joint to joint unless otherwise approved by Architect.
- B. Detailing: Grind concrete "squeeze" left from tool placement. Color ground areas with slurry of color hardener mixed with water and bonding agent. Remove excess release agent with high-velocity blower.
- C. Protect decorative concrete paving from damage. Exclude traffic from paving for at least 14 days after placement. When construction traffic is permitted, maintain paving as clean as possible by removing surface stains and spillage of materials as they occur.
- D. Maintain decorative concrete paving free of stains, discoloration, dirt, and other foreign material. Sweep paving not more than two days before date scheduled for Substantial Completion inspections.

END OF SECTION 321316

SECTION 329200 - TURF AND GRASSES

PART 1 - GENERAL

1.1 SUMMARY

A. Section Includes:

1. Seeding.
2. Sodding.

1.2 DEFINITIONS

- A. Pesticide: A substance or mixture intended for preventing, destroying, repelling, or mitigating a pest. This includes insecticides, miticides, herbicides, fungicides, rodenticides, and molluscicides. It also includes substances or mixtures intended for use as a plant regulator, defoliant, or desiccant.
- B. Planting Soil: Existing, on-site soil; imported soil; or manufactured soil that has been modified with soil amendments and perhaps fertilizers to produce a soil mixture best for plant growth.

1.3 PREINSTALLATION MEETINGS

- A. Preinstallation Conference: Conduct conference at Project site.

1.4 INFORMATIONAL SUBMITTALS

- A. Certification of grass seed.
 1. Certification of each seed mixture for turfgrass sod.
- B. Product certificates.

1.5 QUALITY ASSURANCE

- A. Installer Qualifications: A qualified landscape Installer whose work has resulted in successful turf establishment.
 1. Installer's Field Supervision: Require Installer to maintain an experienced full-time supervisor on Project site when work is in progress.
 2. Personnel Certifications: Installer's field supervisor shall have certification in one of the following categories from the Professional Landcare Network:
 - a. Landscape Industry Certified Technician - Exterior.

- b. Landscape Industry Certified Lawncare Manager.
 - c. Landscape Industry Certified Lawncare Technician.
3. Pesticide Applicator: State licensed, commercial.

1.6 DELIVERY, STORAGE, AND HANDLING

- A. Seed and Other Packaged Materials: Deliver packaged materials in original, unopened containers showing weight, certified analysis, name and address of manufacturer, and indication of compliance with state and Federal laws, as applicable.
- B. Sod: Harvest, deliver, store, and handle sod according to requirements in "Specifications for Turfgrass Sod Materials" and "Specifications for Turfgrass Sod Transplanting and Installation" sections in TPI's "Guideline Specifications to Turfgrass Sodding." Deliver sod within 24 hours of harvesting and in time for planting promptly. Protect sod from breakage and drying.

PART 2 - PRODUCTS

2.1 SEED

- A. Grass Seed: Fresh, clean, dry, new-crop seed complying with AOSA's "Rules for Testing Seeds" for purity and germination tolerances.
- B. Seed Species:
 - 1. Quality: State-certified seed of grass species as listed below for solar exposure.

2.2 TURFGRASS SOD

- A. Turfgrass Sod: State Certified or Approved, complying with "Specifications for Turfgrass Sod Materials" in TPI's "Guideline Specifications to Turfgrass Sodding." Furnish viable sod of uniform density, color, and texture that is strongly rooted and capable of vigorous growth and development when planted.
- B. Turfgrass Species: Sod of grass species as follows:
 - 1. Sun and Partial Shade: Provide proportion and species as selected by certified landscaper that is formulated for geographic location, soil conditions and solar exposure.

2.3 FERTILIZERS

- A. Commercial Fertilizer: Commercial-grade complete fertilizer of neutral character, consisting of fast- and slow-release nitrogen, 50 percent derived from natural organic sources of urea formaldehyde, phosphorous, and potassium in the following composition:

1. Composition: 1 lb/1000 sq. ft. (0.45 kg/92.9 sq. m) of actual nitrogen, 4 percent phosphorous, and 2 percent potassium, by weight.
- B. Slow-Release Fertilizer: Granular or pelleted fertilizer consisting of 50 percent water-insoluble nitrogen, phosphorus, and potassium in the following composition:
 1. Composition: 20 percent nitrogen, 10 percent phosphorous, and 10 percent potassium, by weight.

2.4 MULCHES

- A. Straw Mulch: Provide air-dry, clean, mildew- and seed-free, salt hay or threshed straw of wheat, rye, oats, or barley.

2.5 PESTICIDES

- A. General: Pesticide, registered and approved by the EPA, acceptable to authorities having jurisdiction, and of type recommended by manufacturer for each specific problem and as required for Project conditions and application. Do not use restricted pesticides unless authorized in writing by authorities having jurisdiction.

PART 3 - EXECUTION

3.1 TURF AREA PREPARATION

- A. General: Prepare planting area for soil placement and mix planting soil according to landscaping and planting requirements as shown on drawings.
- B. Reduce elevation of planting soil to allow for soil thickness of sod.
- C. Moisten prepared area before planting if soil is dry. Water thoroughly and allow surface to dry before planting. Do not create muddy soil.
- D. Before planting, obtain Architect's acceptance of finish grading; restore planting areas if eroded or otherwise disturbed after finish grading.

3.2 SEEDING

- A. Sow seed with spreader or seeding machine. Do not broadcast or drop seed when wind velocity exceeds 5 mph (8 km/h).
 1. Evenly distribute seed by sowing equal quantities in two directions at right angles to each other.
 2. Do not use wet seed or seed that is moldy or otherwise damaged.
 3. Do not seed against existing trees. Limit extent of seed to outside edge of planting saucer.

- B. Sow seed at a total rate of 3 to 4 lb/1000 sq. ft. (1.4 to 1.8 kg/92.9 sq. m).
- C. Rake seed lightly into top 1/8 inch (3 mm) of soil, roll lightly, and water with fine spray.
- D. Protect seeded areas with slopes not exceeding 1:6 by spreading straw mulch. Spread uniformly at a minimum rate of 2 tons/acre (42 kg/92.9 sq. m) to form a continuous blanket [1-1/2 inches (38 mm) in loose thickness over seeded areas.

3.3 SODDING

- A. Lay sod within 24 hours of harvesting. Do not lay sod if dormant or if ground is frozen or muddy.
- B. Lay sod to form a solid mass with tightly fitted joints. Butt ends and sides of sod; do not stretch or overlap. Stagger sod strips or pads to offset joints in adjacent courses. Avoid damage to soil or sod during installation. Tamp and roll lightly to ensure contact with soil, eliminate air pockets, and form a smooth surface. Work sifted soil or fine sand into minor cracks between pieces of sod; remove excess to avoid smothering sod and adjacent grass.
 - 1. Lay sod across slopes exceeding 1:3.
 - 2. Anchor sod on slopes exceeding 1:6 with wood pegs or steel staples spaced as recommended by sod manufacturer but not less than two anchors per sod strip to prevent slippage.
- C. Saturate sod with fine water spray within two hours of planting. During first week after planting, water daily or more frequently as necessary to maintain moist soil to a minimum depth of 1-1/2 inches (38 mm) below sod.

3.4 TURF MAINTENANCE

- A. General: Maintain and establish turf by watering, fertilizing, weeding, mowing, trimming, replanting, and performing other operations as required to establish healthy, viable turf. Roll, regrade, and replant bare or eroded areas and remulch to produce a uniformly smooth turf. Provide materials and installation the same as those used in the original installation.
- B. Mow turf as soon as top growth is tall enough to cut. Repeat mowing to maintain specified height without cutting more than one-third of grass height. Remove no more than one-third of grass-leaf growth in initial or subsequent mowings.

3.5 SATISFACTORY TURF

- A. Turf installations shall meet the following criteria as determined by Architect:
 - 1. Satisfactory Seeded Turf: At end of maintenance period, a healthy, uniform, close stand of grass has been established, free of weeds and surface irregularities, with coverage exceeding 90 percent over any 10 sq. ft. (0.92 sq. m) and bare spots not exceeding 5 by 5 inches (125 by 125 mm).

2. Satisfactory Sodded Turf: At end of maintenance period, a healthy, well-rooted, even-colored, viable turf has been established, free of weeds, open joints, bare areas, and surface irregularities.
 - B. Use specified materials to reestablish turf that does not comply with requirements, and continue maintenance until turf is satisfactory.

END OF SECTION 329200

THIS PAGE INTENTIONALLY LEFT BLANK

SECTION 329300 - PLANTS

PART 1 - GENERAL

1.1 SUMMARY

A. Section Includes:

1. Plants.
2. Landscape edgings.

1.2 DEFINITIONS

- A. Backfill: The earth used to replace or the act of replacing earth in an excavation.
- B. Pesticide: A substance or mixture intended for preventing, destroying, repelling, or mitigating a pest. Pesticides include insecticides, miticides, herbicides, fungicides, rodenticides, and molluscicides. They also include substances or mixtures intended for use as a plant regulator, defoliant, or desiccant. Some sources classify herbicides separately from pesticides.
- C. Planting Soil: Existing, on-site soil; imported soil; or manufactured soil that has been modified with soil amendments and perhaps fertilizers to produce a soil mixture best for plant growth. See drawing designations for planting soils.
- D. Root Flare: Also called "trunk flare." The area at the base of the plant's stem or trunk where the stem or trunk broadens to form roots; the area of transition between the root system and the stem or trunk.

1.3 PREINSTALLATION MEETINGS

- A. Preinstallation Conference: Conduct conference at Project site.

1.4 ACTION SUBMITTALS

- A. Product Data: For each type of product.
- B. Samples of each type of mulch.

1.5 INFORMATIONAL SUBMITTALS

- A. Product certificates.
- B. Sample warranty.

1.6 CLOSEOUT SUBMITTALS

- A. Maintenance Data: Recommended procedures to be established by Owner for maintenance of plants during a calendar year.

1.7 QUALITY ASSURANCE

- A. Installer's Field Supervision: Require Installer to maintain an experienced full-time supervisor on Project site when work is in progress.
 - 1. Pesticide Applicator: State licensed, commercial.
- B. Provide quality, size, genus, species, and variety of plants indicated, complying with applicable requirements in ANSI Z60.1.

1.8 DELIVERY, STORAGE, AND HANDLING

- A. Deliver bare-root stock plants within 36 hours of digging. Immediately after digging up bare-root stock, pack root system in wet straw, hay, or other suitable material to keep root system moist until planting. Transport in covered, temperature-controlled vehicles, and keep plants cool and protected from sun and wind at all times.
- B. Do not prune trees and shrubs before delivery. Protect bark, branches, and root systems from sun scald, drying, wind burn, sweating, whipping, and other handling and tying damage. Do not bend or bind-tie trees or shrubs in such a manner as to destroy their natural shape. Provide protective covering of plants during shipping and delivery. Do not drop plants during delivery and handling.
- C. Handle planting stock by root ball.
- D. Store bulbs, corms, and tubers in a dry place at 60 to 65 deg F (16 to 18 deg C) until planting.
- E. Deliver plants after preparations for planting have been completed, and install immediately. If planting is delayed more than six hours after delivery, set plants and trees in their appropriate aspect (sun, filtered sun, or shade), protect from weather and mechanical damage, and keep roots moist.

1.9 WARRANTY

- A. Special Warranty: Installer agrees to repair or replace plantings and accessories that fail in materials, workmanship, or growth within specified warranty period.
 - 1. Failures include, but are not limited to, the following:
 - a. Death and unsatisfactory growth, except for defects resulting from abuse, lack of adequate maintenance, or neglect by Owner.
 - b. Structural failures including plantings falling or blowing over.

2. Warranty Periods: From date of Substantial Completion.
 - a. Trees, Shrubs, Vines, and Ornamental Grasses: 12 months.
 - b. Ground Covers, Biennials, Perennials, and Other Plants: 12 months.
 - c. Annuals: Three months.

PART 2 - PRODUCTS

2.1 PLANT MATERIAL

- A. General: Furnish nursery-grown plants true to genus, species, variety, cultivar, stem form, shearing, and other features indicated in Plant List, Plant Schedule, or Plant Legend indicated on Drawings and complying with ANSI Z60.1; and with healthy root systems developed by transplanting or root pruning. Provide well-shaped, fully branched, healthy, vigorous stock, densely foliated when in leaf and free of disease, pests, eggs, larvae, and defects such as knots, sun scald, injuries, abrasions, and disfigurement.
- B. Root-Ball Depth: Furnish trees and shrubs with root balls measured from top of root ball, which begins at root flare according to ANSI Z60.1. Root flare shall be visible before planting.
- C. Annuals and Biennials: Provide healthy, disease-free plants of species and variety shown or listed, with well-established root systems reaching to sides of the container to maintain a firm ball, but not with excessive root growth encircling the container. Provide only plants that are acclimated to outdoor conditions before delivery.

2.2 FERTILIZERS

- A. Planting Tablets: Tightly compressed chip-type, long-lasting, slow-release, commercial-grade planting fertilizer in tablet form. Tablets shall break down with soil bacteria, converting nutrients into a form that can be absorbed by plant roots.
 1. Size: 10-gram] [21-gram tablets.
 2. Nutrient Composition: 20 percent nitrogen, 10 percent phosphorous, and 5 percent potassium, by weight plus micronutrients.

2.3 MULCHES

- A. Organic Mulch: Shredded hardwood.

2.4 WEED-CONTROL BARRIERS

- A. Nonwoven Geotextile Filter Fabric: Polypropylene or polyester fabric, 3 oz./sq. yd. (101g/sq. m) minimum, composed of fibers formed into a stable network so that fibers retain their relative position. Fabric shall be inert to biological degradation and resist naturally encountered chemicals, alkalis, and acids.

2.5 PESTICIDES

- A. General: Pesticide registered and approved by the EPA, acceptable to authorities having jurisdiction, and of type recommended by manufacturer for each specific problem and as required for Project conditions and application. Do not use restricted pesticides unless authorized in writing by authorities having jurisdiction.

2.6 LANDSCAPE EDGINGS

- A. Plastic Edging: Standard black polyethylene or vinyl edging, horizontally grooved, extruded in standard lengths, with 9-inch (225-mm) plastic stakes.
 - 1. Manufacturers: Subject to compliance with requirements, provide products by one of the following:
 - a. Oly-Ola Edgings, Inc.
 - b. Permaloc Corporation.
 - c. Sure-loc Edging Corporation.
 - d. Valley View Industries.
 - e. Villa Root Barrier.
 - 2. Edging Size: 0.1 inch (2.5 mm) thick by 5 inches (125 mm) deep.

PART 3 - EXECUTION

3.1 PLANTING AREA ESTABLISHMENT

- A. General: Prepare planting area for soil placement and mix planting soil according to Section 312000 "Earthwork" and drawings.
- B. Placing Planting Soil: Place and mix planting soil in-place over exposed subgrade.
- C. Before planting, obtain Architect's acceptance of finish grading; restore planting areas if eroded or otherwise disturbed after finish grading.

3.2 EXCAVATION FOR TREES AND SHRUBS

- A. Planting Pits and Trenches: Excavate circular planting pits.
 - 1. Excavate planting pits with sides sloping inward at a 45-degree angle. Excavations with vertical sides are unacceptable. Trim perimeter of bottom leaving center area of bottom raised slightly to support root ball and assist in drainage away from center. Do not further disturb base. Ensure that root ball will sit on undisturbed base soil to prevent settling. Scarify sides of planting pit smeared or smoothed during excavation.
 - 2. Excavate approximately three times as wide as ball diameter.

3. Excavate at least 12 inches (300 mm) wider than root spread and deep enough to accommodate vertical roots for bare-root stock.
 4. Do not excavate deeper than depth of the root ball, measured from the root flare to the bottom of the root ball.
- B. Backfill Soil: Topsoil removed from excavations may be used as backfill soil unless otherwise indicated.

3.3 TREE, SHRUB, AND VINE PLANTING

- A. Inspection: At time of planting, verify that root flare is visible at top of root ball according to ANSI Z60.1. If root flare is not visible, remove soil in a level manner from the root ball to where the top-most root emerges from the trunk. After soil removal to expose the root flare, verify that root ball still meets size requirements.
- B. Roots: Remove stem girdling roots and kinked roots. Remove injured roots by cutting cleanly; do not break.
- C. Set each plant plumb and in center of planting pit or trench with root flare 1 inch (25 mm) above adjacent finish grades.
1. Backfill: Planting soi. For trees, use excavated soil may be used for backfill.
 2. Balled and Burlapped Stock: After placing some backfill around root ball to stabilize plant, carefully cut and remove burlap, rope, and wire baskets from tops of root balls and from sides, but do not remove from under root balls. Remove pallets, if any, before setting. Do not use planting stock if root ball is cracked or broken before or during planting operation.
 3. Balled and Potted and Container-Grown Stock: Carefully remove root ball from container without damaging root ball or plant.
 4. Fabric Bag-Grown Stock: Carefully remove root ball from fabric bag without damaging root ball or plant. Do not use planting stock if root ball is cracked or broken before or during planting operation.
 5. Bare-Root Stock: Support stem of each plant and spread roots without tangling or turning toward surface. Plumb before backfilling, and maintain plumb while working. Carefully work backfill around roots by hand. Bring roots into close contact with the soil.
 6. Backfill around root ball in layers, tamping to settle soil and eliminate voids and air pockets. When planting pit is approximately one-half filled, water thoroughly before placing remainder of backfill. Repeat watering until no more water is absorbed.
 7. Place planting tablets equally distributed around each planting pit when pit is approximately one-half filled. Place tablets beside the root ball about **1 inch (25 mm)** from root tips; do not place tablets in bottom of the hole.
 - a. Bare-Root Stock: Place tablets beside soil-covered roots; do not place tablets touching the roots.
 - b. Quantity: Two per plant.
 8. Continue backfilling process. Water again after placing and tamping final layer of soil.

- D. Slopes: When planting on slopes, set the plant so the root flare on the uphill side is flush with the surrounding soil on the slope; the edge of the root ball on the downhill side will be above the surrounding soil. Apply enough soil to cover the downhill side of the root ball.

3.4 TREE, SHRUB, AND VINE PRUNING

- A. Remove only dead, dying, or broken branches. Do not prune for shape.
- B. Prune, thin, and shape trees, shrubs, and vines as directed by Architect.
- C. Prune, thin, and shape trees, shrubs, and vines according to standard professional horticultural and arboricultural practices. Unless otherwise indicated by Architect, do not cut tree leaders; remove only injured, dying, or dead branches from trees and shrubs; and prune to retain natural character.
- D. Do not apply pruning paint to wounds.

3.5 GROUND COVER AND PLANT PLANTING

- A. Set out and space ground cover and plants other than trees, shrubs, and vines as indicated on Drawings but not less than 12 inches (300 mm) apart in even rows with triangular spacing.
- B. Use planting soil for backfill.
- C. Dig holes large enough to allow spreading of roots.
- D. Work soil around roots to eliminate air pockets and leave a slight saucer indentation around plants to hold water.
- E. Water thoroughly after planting, taking care not to cover plant crowns with wet soil.
- F. Protect plants from hot sun and wind; remove protection if plants show evidence of recovery from transplanting shock.

3.6 PLANTING AREA MULCHING

- A. Install weed-control barriers before mulching according to manufacturer's written instructions. Completely cover area to be mulched, overlapping edges a minimum of 6 inches (150 mm) and secure seams with galvanized pins.
- B. Mulch backfilled surfaces of planting areas and other areas indicated.
 - 1. Trees in Turf Areas: Apply organic mulch ring of 3-inch (75-mm) average thickness, with 24-inch (600-mm) radius around trunks or stems. Do not place mulch within 3 inches (75 mm) of trunks or stems.
 - 2. Organic Mulch in Planting Areas: Apply 2-inch (50-mm) average thickness of organic mulch extending 12 inches (300 mm) beyond edge of individual planting pit or trench

and over whole surface of planting area, and finish level with adjacent finish grades. Do not place mulch within 3 inches (75 mm) of trunks or stems.

3.7 EDGING INSTALLATION

- A. Plastic Edging: Install plastic edging where indicated according to manufacturer's written instructions. Anchor with steel stakes spaced approximately 48 inches (1200 mm) apart, driven through upper base grooves or V-lip of edging.

3.8 PLANT MAINTENANCE

- A. Maintain plantings by pruning, cultivating, watering, weeding, fertilizing, mulching, restoring planting saucers, resetting to proper grades or vertical position, and performing other operations as required to establish healthy, viable plantings.
- B. Fill in, as necessary, soil subsidence that may occur because of settling or other processes. Replace mulch materials damaged or lost in areas of subsidence.
- C. Apply treatments as required to keep plant materials, planted areas, and soils free of pests and pathogens or disease. Use integrated pest management practices when possible to minimize use of pesticides and reduce hazards. Treatments include physical controls such as hosing off foliage, mechanical controls such as traps, and biological control agents.
- D. Apply pesticides and other chemical products and biological control agents according to authorities having jurisdiction and manufacturer's written recommendations. Coordinate applications with Owner's operations and others in proximity to the Work. Notify Owner before each application is performed.
- E. Protect plants from damage due to landscape operations and operations of other contractors and trades. Maintain protection during installation and maintenance periods. Treat, repair, or replace damaged plantings.
- F. At time of Substantial Completion, verify that tree-watering devices are in good working order and leave them in place. Replace improperly functioning devices.

3.9 MAINTENANCE SERVICE

- A. Maintenance Service: Provide maintenance by skilled employees of landscape Installer. Maintain as required in "Plant Maintenance" Article. Begin maintenance immediately after plants are installed and continue until plantings are acceptably healthy and well established, but for not less than maintenance period below:
 - 1. Maintenance Period for Trees, Shrubs, Ground Cover and Other Plants: Three months from date of Substantial Completion.

END OF SECTION 329300

THIS PAGE INTENSIONALLY LEFT BLANK

SECTION 330500 - COMMON WORK RESULTS FOR UTILITIES

PART 1 - GENERAL

1.1 RELATED DOCUMENTS

- A. Drawings and general provisions of the Contract, including General and Supplementary Conditions and Division 01 Specification Sections, apply to this Section.

1.2 SUMMARY

- A. This Section includes the following:
 - 1. Piping joining materials.
 - 2. Transition fittings.
 - 3. Dielectric fittings.
 - 4. Sleeves.
 - 5. Piped utility demolition.
 - 6. Piping system common requirements.
 - 7. Concrete bases.
 - 8. Appendix – Arlington County Conduit Construction Standards

1.3 DEFINITIONS

- A. Exposed Installations: Exposed to view outdoors or subject to outdoor ambient temperatures and weather conditions.
- B. Concealed Installations: Concealed from view and protected from weather conditions and physical contact by building occupants but subject to outdoor ambient temperatures. Examples include installations within unheated shelters.
- C. ABS: Acrylonitrile-butadiene-styrene plastic.
- D. CPVC: Chlorinated polyvinyl chloride plastic.
- E. PE: Polyethylene plastic.
- F. PVC: Polyvinyl chloride plastic.
- G. HDPE: High density polyethylene corrugated drainage pipe.

1.4 SUBMITTALS

- A. Product Data: For the following:

1. Dielectric fittings.

- B. Contractor shall supply all design, details and specifications for the relocation of the existing light fixtures, including pole bases and anchorage, electrical conduit, wiring, connections, etc for owner and engineer review and approval prior to installation.

1.5 QUALITY ASSURANCE

- A. Comply with ASME A13.1 for lettering size, length of color field, colors, and viewing angles of identification devices.

1.6 DELIVERY, STORAGE, AND HANDLING

- A. Deliver pipes and tubes with factory-applied end caps. Maintain end caps through shipping, storage, and handling to prevent pipe end damage and to prevent entrance of dirt, debris, and moisture.
- B. Store plastic pipes protected from direct sunlight. Support to prevent sagging and bending.

1.7 COORDINATION

- A. Coordinate installation of required supporting devices and set sleeves in poured-in-place concrete and other structural components as they are constructed.
- B. Coordinate installation of identifying devices after completing covering and painting if devices are applied to surfaces.
- C. Coordinate size and location of concrete bases. Formwork, reinforcement, and concrete requirements are specified in Division 03.

PART 2 - PRODUCTS

2.1 PIPING JOINING MATERIALS

- A. Flange Bolts and Nuts: ASME B18.2.1, carbon steel, unless otherwise indicated.
- B. Plastic, Pipe-Flange Gasket, Bolts, and Nuts: Type and material recommended by piping system manufacturer, unless otherwise indicated.
- C. Solvent Cements for Joining Plastic Piping:
1. ABS Piping: ASTM D 2235.
 2. CPVC Piping: ASTM F 493.
 3. PVC Piping: ASTM D 2564. Include primer according to ASTM F 656.
 4. PVC to ABS Piping Transition: ASTM D 3138.

2.2 TRANSITION FITTINGS

- A. Transition Fittings, General: Same size as, and with pressure rating at least equal to and with ends compatible with, piping to be joined.
- B. Transition Couplings NPS 1-1/2 (DN 40) and Smaller:
1. Underground Piping: Manufactured piping coupling or specified piping system fitting.
 2. Aboveground Piping: Specified piping system fitting.
- C. Plastic-to-Metal Transition Fittings:
1. Available Manufacturers: Subject to compliance with requirements, manufacturers offering products that may be incorporated into the Work include, but are not limited to, the following:
 2. Manufacturers: Subject to compliance with requirements, provide products by one of the following:
 - a. Spears Manufacturing Co.
 - b. Conforming to Owner standards.
 3. Description: CPVC and PVC one-piece fitting with manufacturer's Schedule 80 equivalent dimensions; one end with threaded brass insert, and one solvent-cement-joint or threaded end.
- D. Plastic-to-Metal Transition Unions:
1. Available Manufacturers: Subject to compliance with requirements, manufacturers offering products that may be incorporated into the Work include, but are not limited to, the following:
 2. Manufacturers: Subject to compliance with requirements, provide products by one of the following:
 - a. Colonial Engineering, Inc.
 - b. NIBCO INC.
 - c. Spears Manufacturing Co.
 - d. Conforming to Owner standards.
 3. Description: MSS SP-107, CPVC CPVC and PVC four-part union. Include brass threaded end, solvent-cement-joint or threaded plastic end, rubber O-ring, and union nut.
- E. Flexible Transition Couplings for Underground Nonpressure Drainage and Conduit Piping:
1. Available Manufacturers: Subject to compliance with requirements, manufacturers offering products that may be incorporated into the Work include, but are not limited to, the following:
 2. Manufacturers: Subject to compliance with requirements, provide products by one of the following:
 - a. Cascade Waterworks Mfg. Co.

- b. Fernco, Inc.
 - c. Mission Rubber Company.
 - d. Plastic Oddities.
 - e. Conforming to Owner standards
3. Description: ASTM C 1173 with elastomeric sleeve, ends same size as piping to be joined, and corrosion-resistant metal band on each end.

2.3 DIELECTRIC FITTINGS

A. Dielectric Fittings, General: Assembly of copper alloy and ferrous materials or ferrous material body with separating nonconductive insulating material suitable for system fluid, pressure, and temperature.

B. Dielectric Unions:

1. Available Manufacturers: Subject to compliance with requirements, manufacturers offering products that may be incorporated into the Work include, but are not limited to, the following:
2. Manufacturers: Subject to compliance with requirements, provide products by one of the following:
 - a. Capitol Manufacturing Co.
 - b. Central Plastics Company.
 - c. Epcos Sales, Inc.
 - d. Hart Industries, International, Inc.
 - e. Watts Water Technologies, Inc.
 - f. Zurn Plumbing Products Group; Wilkins Div.
 - g. Conforming to Owner standards.
3. Description: Factory fabricated, union, NPS 2 (DN 50) and smaller.
 - a. Pressure Rating: 150 psig (1035 kPa) minimum at 180 deg F (82 deg C).
 - b. End Connections: Solder-joint copper alloy and threaded ferrous; threaded ferrous.

C. Dielectric Flanges:

1. Available Manufacturers: Subject to compliance with requirements, manufacturers offering products that may be incorporated into the Work include, but are not limited to, the following:
2. Manufacturers: Subject to compliance with requirements, provide products by one of the following:
 - a. Capitol Manufacturing Co.
 - b. Central Plastics Company.
 - c. Epcos Sales, Inc.
 - d. Watts Water Technologies, Inc.
 - e. Conforming to Owner standards.

3. Description: Factory-fabricated, bolted, companion-flange assembly, NPS 2-1/2 to NPS 4 (DN 65 to DN 100) and larger.
 - a. Pressure Rating: Conforming to Fairfax County PFM standards.
 - b. End Connections: Solder-joint copper alloy and threaded ferrous; threaded solder-joint copper alloy and threaded ferrous.

D. Dielectric-Flange Kits:

1. Available Manufacturers: Subject to compliance with requirements, manufacturers offering products that may be incorporated into the Work include, but are not limited to, the following:
2. Manufacturers: Subject to compliance with requirements, provide products by one of the following:
 - a. Advance Products & Systems, Inc.
 - b. Calpico, Inc.
 - c. Central Plastics Company.
 - d. Pipeline Seal and Insulator, Inc.
 - e. Conforming to Owner standards.
3. Description: Nonconducting materials for field assembly of companion flanges, NPS 2-1/2 (DN 65) and larger.
 - a. Pressure Rating: Conforming to Owner standards.
 - b. Gasket: Neoprene or phenolic.
 - c. Bolt Sleeves: Phenolic or polyethylene.
 - d. Washers: Phenolic with steel backing washers.

E. Dielectric Couplings:

1. Available Manufacturers: Subject to compliance with requirements, manufacturers offering products that may be incorporated into the Work include, but are not limited to, the following:
2. Manufacturers: Subject to compliance with requirements, provide products by one of the following:
 - a. Calpico, Inc.
 - b. Lochinvar Corporation.
 - c. Conforming to Owner standards.
3. Description: Galvanized-steel coupling with inert and noncorrosive, thermoplastic lining, NPS 3 (DN 80) and smaller.
 - a. Pressure Rating: 300 psig (2070 kPa) at 225 deg F (107 deg C).
 - b. End Connections: Threaded.

F. Dielectric Nipples:

1. Available Manufacturers: Subject to compliance with requirements, manufacturers offering products that may be incorporated into the Work include, but are not limited to, the following:
2. Manufacturers: Subject to compliance with requirements, provide products by one of the following:
 - a. Perfection Corporation.
 - b. Precision Plumbing Products, Inc.
 - c. Victaulic Company.
 - d. Conforming to Owner standards.
3. Description: Electroplated steel nipple with inert and noncorrosive, thermoplastic lining.
 - a. Pressure Rating: Conforming to Fairfax County PFM standards.
 - b. End Connections: Threaded or grooved.

2.4 SLEEVES

- A. Galvanized-Steel Sheet Sleeves: 0.0239-inch (0.6-mm) minimum thickness; round tube closed with welded longitudinal joint.
- B. Steel Pipe Sleeves: ASTM A 53/A 53M, Type E, Grade B, Schedule 40, galvanized, plain ends.
- C. PVC Pipe Sleeves: ASTM D 1785, Schedule 40.

2.5 GROUT

- A. Description: ASTM C 1107, Grade B, nonshrink and nonmetallic, dry hydraulic-cement grout.
 1. Characteristics: Post hardening, volume adjusting, nonstaining, noncorrosive, nongaseous, and recommended for interior and exterior applications.
 2. Design Mix: 5000-psi (34.5-MPa), 28-day compressive strength.
 3. Packaging: Premixed and factory packaged.

PART 3 - EXECUTION

3.1 PIPED UTILITY DEMOLITION

- A. Refer to Division 01 Section "Cutting and Patching" and Division 02 Section "Site Demolition" for general demolition requirements and procedures.
- B. Disconnect, demolish, and remove piped utility systems, equipment, and components indicated to be removed.
 1. Piping to Be Removed: Remove portion of piping indicated to be removed and cap or plug remaining piping with same or compatible piping material.

2. Piping to Be Abandoned in Place: Drain piping. Fill abandoned piping with flowable fill, and cap or plug piping with same or compatible piping material.
 3. Equipment to Be Removed: Disconnect and cap services and remove equipment.
 4. Equipment to Be Removed and Reinstalled: Disconnect and cap services and remove, clean, and store equipment; when appropriate, reinstall, reconnect, and make operational.
 5. Equipment to Be Removed and Salvaged: Disconnect and cap services and remove equipment and deliver to Owner.
- C. If pipe, insulation, or equipment to remain is damaged in appearance or is unserviceable, remove damaged or unserviceable portions and replace with new products of equal capacity and quality.

3.2 DIELECTRIC FITTING APPLICATIONS

- A. Dry Piping Systems: Connect piping of dissimilar metals with the following:
1. NPS 2 (DN 50) and Smaller: Dielectric unions.
 2. NPS 2-1/2 to NPS 12 (DN 65 to DN 300): Dielectric flanges or dielectric flange kits.
- B. Wet Piping Systems: Connect piping of dissimilar metals with the following:
1. NPS 2 (DN 50) and Smaller: Dielectric couplings or dielectric nipples.
 2. NPS 2-1/2 to NPS 4 (DN 65 to DN 100): Dielectric nipples.
 3. NPS 2-1/2 to NPS 8 (DN 65 to DN 200): Dielectric nipples or dielectric flange kits.
 4. NPS 10 and NPS 12 (DN 250 and DN 300): Dielectric flange kits.

3.3 PIPING INSTALLATION

- A. Install piping according to the following requirements and Division 33 Sections specifying piping systems.
- B. Contractor to supply drawing plans, schematics, and diagrams to indicate general location and arrangement of lighting conduit piping systems. Install piping as indicated unless deviations to layout are approved on the Coordination Drawings.
- C. Install piping at indicated slopes.
- D. Install piping free of sags and bends.
- E. Install fittings for changes in direction and branch connections.

3.4 PIPING JOINT CONSTRUCTION

- A. Join pipe and fittings according to the following requirements.
- B. Ream ends of pipes and tubes and remove burrs. Bevel plain ends of steel pipe.

- C. Remove scale, slag, dirt, and debris from inside and outside of pipe and fittings before assembly.
- D. Threaded Joints: Thread pipe with tapered pipe threads according to ASME B1.20.1. Cut threads full and clean using sharp dies. Ream threaded pipe ends to remove burrs and restore full ID. Join pipe fittings and valves as follows:
 - 1. Apply appropriate tape or thread compound to external pipe threads unless dry seal threading is specified.
 - 2. Damaged Threads: Do not use pipe or pipe fittings with threads that are corroded or damaged. Do not use pipe sections that have cracked or open welds.
- E. Flanged Joints: Select appropriate gasket material, size, type, and thickness for service application. Install gasket concentrically positioned. Use suitable lubricants on bolt threads.
- F. Grooved Joints: Assemble joints with grooved-end pipe coupling with coupling housing, gasket, lubricant, and bolts according to coupling and fitting manufacturer's written instructions.
- G. Soldered Joints: Apply ASTM B 813 water-flushable flux, unless otherwise indicated, to tube end. Construct joints according to ASTM B 828 or CDA's "Copper Tube Handbook," using lead-free solder alloy (0.20 percent maximum lead content) complying with ASTM B 32.
- H. Brazed Joints: Construct joints according to AWS's "Brazing Handbook," "Pipe and Tube" Chapter, using copper-phosphorus brazing filler metal complying with AWS A5.8.
- I. Pressure-Sealed Joints: Assemble joints for plain-end copper tube and mechanical pressure seal fitting with proprietary crimping tool to according to fitting manufacturer's written instructions.
- J. Plastic Piping Solvent-Cemented Joints: Clean and dry joining surfaces. Join pipe and fittings according to the following:
 - 1. Comply with ASTM F 402 for safe-handling practice of cleaners, primers, and solvent cements.
 - 2. ABS Piping: Join according to ASTM D 2235 and ASTM D 2661 appendixes.
 - 3. CPVC Piping: Join according to ASTM D 2846/D 2846M Appendix.
 - 4. PVC Pressure Piping: Join schedule number ASTM D 1785, PVC pipe and PVC socket fittings according to ASTM D 2672. Join other-than-schedule-number PVC pipe and socket fittings according to ASTM D 2855.
 - 5. PVC Nonpressure Piping: Join according to ASTM D 2855.
 - 6. PVC to ABS Nonpressure Transition Fittings: Join according to ASTM D 3138 Appendix.
- K. Plastic Nonpressure Piping Gasketed Joints: Join according to ASTM D 3212.
- L. Plastic Piping Heat-Fusion Joints: Clean and dry joining surfaces by wiping with clean cloth or paper towels. Join according to ASTM D 2657.
 - 1. Plain-End PE Pipe and Fittings: Use butt fusion.
 - 2. Plain-End PE Pipe and Socket Fittings: Use socket fusion.

- M. Bonded Joints: Prepare pipe ends and fittings, apply adhesive, and join according to pipe manufacturer's written instructions.

3.5 PIPING CONNECTIONS

- A. Make connections according to the following, unless otherwise indicated:
 1. Install unions, in piping NPS 2 (DN 50) and smaller, adjacent to each valve and at final connection to each piece of equipment.
 2. Install flanges, in piping NPS 2-1/2 (DN 65) and larger, adjacent to flanged valves and at final connection to each piece of equipment.
 3. Install dielectric fittings at connections of dissimilar metal pipes.

3.6 EQUIPMENT INSTALLATION

- A. Install equipment level and plumb, unless otherwise indicated.
- B. Install equipment to facilitate service, maintenance, and repair or replacement of components. Connect equipment for ease of disconnecting, with minimum interference with other installations. Extend grease fittings to an accessible location.
- C. Install equipment to allow right of way to piping systems installed at required slope.

3.7 CONCRETE BASES

- A. Concrete Bases: Anchor equipment to concrete base according to equipment manufacturer's written instructions and according to seismic codes at Project.
 1. Construct concrete bases of dimensions indicated, but not less than 4 inches (100 mm) larger in both directions than supported unit.
 2. Install dowel rods to connect concrete base to concrete floor. Unless otherwise indicated, install dowel rods on 18-inch (450-mm) centers around the full perimeter of base.
 3. Install epoxy-coated anchor bolts for supported equipment that extend through concrete base, and anchor into structural concrete floor.
 4. Place and secure anchorage devices. Use supported equipment manufacturer's setting drawings, templates, diagrams, instructions, and directions furnished with items to be embedded.
 5. Install anchor bolts to elevations required for proper attachment to supported equipment.
 6. Install anchor bolts according to anchor-bolt manufacturer's written instructions.
 7. Use 3000-psi (20.7-MPa), 28-day compressive-strength concrete and reinforcement as specified in Division 03 Section "Cast-in-Place Concrete."

3.8 GROUTING

- A. Mix and install grout for equipment base bearing surfaces, pump and other equipment base plates, and anchors.

- B. Clean surfaces that will come into contact with grout.
- C. Provide forms as required for placement of grout.
- D. Avoid air entrapment during placement of grout.
- E. Place grout, completely filling equipment bases.
- F. Place grout on concrete bases and provide smooth bearing surface for equipment.
- G. Place grout around anchors.
- H. Cure placed grout.

END OF SECTION 330500

ARLINGTON COUNTY CONDUIT CONSTRUCTION STANDARDS
Appendix to Section 330500 follows

ARLINGTON COUNTY CONDUIT CONSTRUCTION STANDARDS

DRAFT – September 2020

Appendix to Section 330500 “Common Work Results for Utilities” Communications Conduit

1. Materials:

- (a) Polyvinyl chloride (PVC) conduit shall be schedule 40, schedule 80, or high-density polyethylene (HDPE) as determined on the plan set or as directed by the County Representative. All couplings, elbows, bushings, and other conduit fittings shall be of the same quality, strength, and grade of workmanship as the conduit and shall be manufactured expressly for use with the conduit
- (b) Steel conduit and fittings shall be galvanized and heavy wall and shall meet ANSI C80.1, American National Standard for Electrical Rigid Steel Conduit, and UL 6, Electrical Rigid Metal Conduit-Steel. All couplings, elbows, bushings, and other conduit fittings shall be of the same quality, strength, and grade of workmanship as the conduit and shall be manufactured expressly for use with the conduit.
- (c) All transitions from HDPE pipe to PVC shall be by means of an aluminum threaded coupling or ETCO E-LOC coupling. These couplings are the only approved method for connecting the 90 degree sweep.

2. Execution:

(a) General conduit installation

- (1) Conduit direction changes shall be accomplished by using sweeping elbows or field bends. All bends shall meet the requirements in NEC Article 346 for rigid metallic conduit or NEC Article 347 for rigid non-metallic conduit.
- (2) There shall be no more than the equivalent of three quarter or 90 degree bends (270 degrees total) between pull points (e.g., buildings to boxes, poles to boxes and boxes to boxes).
- (3) Sequentially numbered pull tape with distance marked in feet shall be install in all conduits. The line shall be firmly secured at each end of the conduit run. The purpose of the pull tape is to provide a means of pulling future cable through the existing conduit runs.
- (4) Tracer wire (solid copper 14 AWG with thermoplastic high-heat-resistant nylon-coated (THHN) green shall be installed from junction box to junction box.

- Multiple conduit runs in the same trench shall have tracer wire in at least one conduit. Tracer wire shall be one continuous run without any splices.
- (5) Conduits shall always enter a junction box/ handhole, or any other type of structure from the direction of the run only. Conduit connections at junction boxes shall be tightly secured.
 - (6) Conduits terminating in the sides of a junction box/ handhole shall extend approximately 2-3 into junction box from direction of trench or boring.
 - (7) Existing underground conduit to be incorporated into a new system shall be cleaned with a mandrel or blown out with compressed air.
 - (8) The opening of any spare or unused conduits shall be sealed with reusable, mechanical expansion duct plugs. Each duct plugs for empty conduit shall be have a loop nut and rope tie.
 - (9) All conduit, including HDPE pipe, shall be installed at full depth for the entire conduit run until rising to enter the side of the handhole.
 - (10) All conduits in junction boxes shall extend from the HH sides, a minimum of 3 inches above crushed rock.

(b) Trenching

- (1) Unless otherwise shown or approved by the Engineer or authorized representative, conduits shall be placed at a minimum cover of 36 inches. In accordance with VDOT regulations, all conduits shall be buried with a minimum of 36 inches of cover until rising to enter into sides of HH's. Entry into HH sides to be 3-6" from gravel bottom.
- (2) Conduit with a depth less than 24 inches shall be encased in concrete.
- (3) Concrete-encased PVC conduit shall have a minimum of 3 inches of concrete on the top, bottom, and sides of the conduit, with 1-1/2 inches of spacing between conduits.
- (4) All trenching shall conform to Arlington County Construction Standards and Specifications; Section 02200, Earthwork; and Section 02650, Restoration of Roadway.
- (5) Where multiple conduits are installed in a single trench, the conduits shall be separated by 1 inch of sand or by prefabricated conduit spacing units.
- (6) Trenches shall be free of cinders, broken concrete, and other hard, abrasive, or sharp materials before conduit placement.
- (7) The Contractor shall take measures to preserve the existing landscaping. When trenching in earth, the Contractor shall carefully remove the existing sod and then put the new sod into place when the work is complete. The Contractor shall put all earth that has been excavated on a plastic sheet to protect the existing landscaping.

- (8) The Contractor shall secure the trench at the end of every workday with back fill or steel plates when needed. Restoration shall include backfilling, compacting, and placing the sod.
- (9) Test holes shall be dug in accordance with the Virginia Professional Excavator's Manual and Miss Utility guidelines for test pits.

(c) Horizontal Directional Drilling

- (1) The Contractor shall be required to dig test pits where new conduit crosses underground utilities, as specified on the plans or as directed by the Engineer to ensure that adequate utility clearances are met.
- (2) Test holes shall be dug in accordance with the Virginia Professional Excavator's Manual and Miss Utility guidelines for test pits.
- (3) Bored conduits shall adhere to the same depth requirements as trenched conduits 36" and shall adhere to appropriate clearances from utilities. The nominal depth for directional drilling is between 40 and 48 inches.
- (4) Boring depth of less than 36" will need approval from county engineer.
- (5) Boring depth to rise to 30" below final grade prior to HH entry HH sides to be 3-6" from gravel bottom.

THIS PAGE INTENSIONALLY LEFT BLANK