

ADDENDUM NO. 1
BENJAMIN HILL LINEAR PARK
CITY OF LAGRAGE
LAGRANGE, GEORGIA

DRAWINGS

Replace sheets L1.01 – L1.03 with attached.

Sheet C1.03 KEYED NOTES: NOTE 2

Replace

“TACTILE” with “DETECTABLE”

Sheet C2.01

Change Callout

“CORE EXIST. CB @ INV 704.50”

To

“CORE EXIST. CB @ INV 704.80”

Sheet L1.00 SITE FURNISHINGS SCHEDULE; STANDART BACKED BENCH

Change QTY from

“2” to “4”

Sheet L3.00 Detail 2; Note 1;

Remove

“SEE DETAIL 3. SHEET L7.05”

Sheet L3.00 Detail 3A Callout

“CAST STONE CAP W/ EQUALLY SPACED JOINTS (4'MAX); SEE MATERIALS SCHEDULE /L1.00”

Remove

“SEE SCHEDULE

SPECIFICATIONS

Section 01 57 13;1.2; A

Change

“Section 01 33 23”

to

“Section 01 33 00”

Section 01 57 13;3.2; E;1

Change

“Refer to Specification 32 92 19 Permanent Seeding and 32 92 23 Permanent Sodding...”

to

“Refer to Specification 32 90 00 Exterior Landscape...”

Section 04 22 00

Remove Section

1.2 Related Sections.

Section 32 31 19

Remove Section

1.2; C. Related Requirements

Section 32 90 00

Remove Section

2.8 Miscellaneous Landscape Materials; G. Mulch, as indicated on plans;
1. Shredded Hardwood Bark Mulch

Bidder Must Acknowledge Receipt of this Addendum on Bid Form

May 19, 2021
Barge Design Solutions, Inc.
1201 Front Ave, Suite F
Columbus, Georgia 31901
706-321-4590

USER:LELOVE
 FILE:G:\36\3643207\04_CAD\LAND\PIAS\3643207L101.dwg
 SAVE:4/30/2021
 PLOTTED:5/12/2021

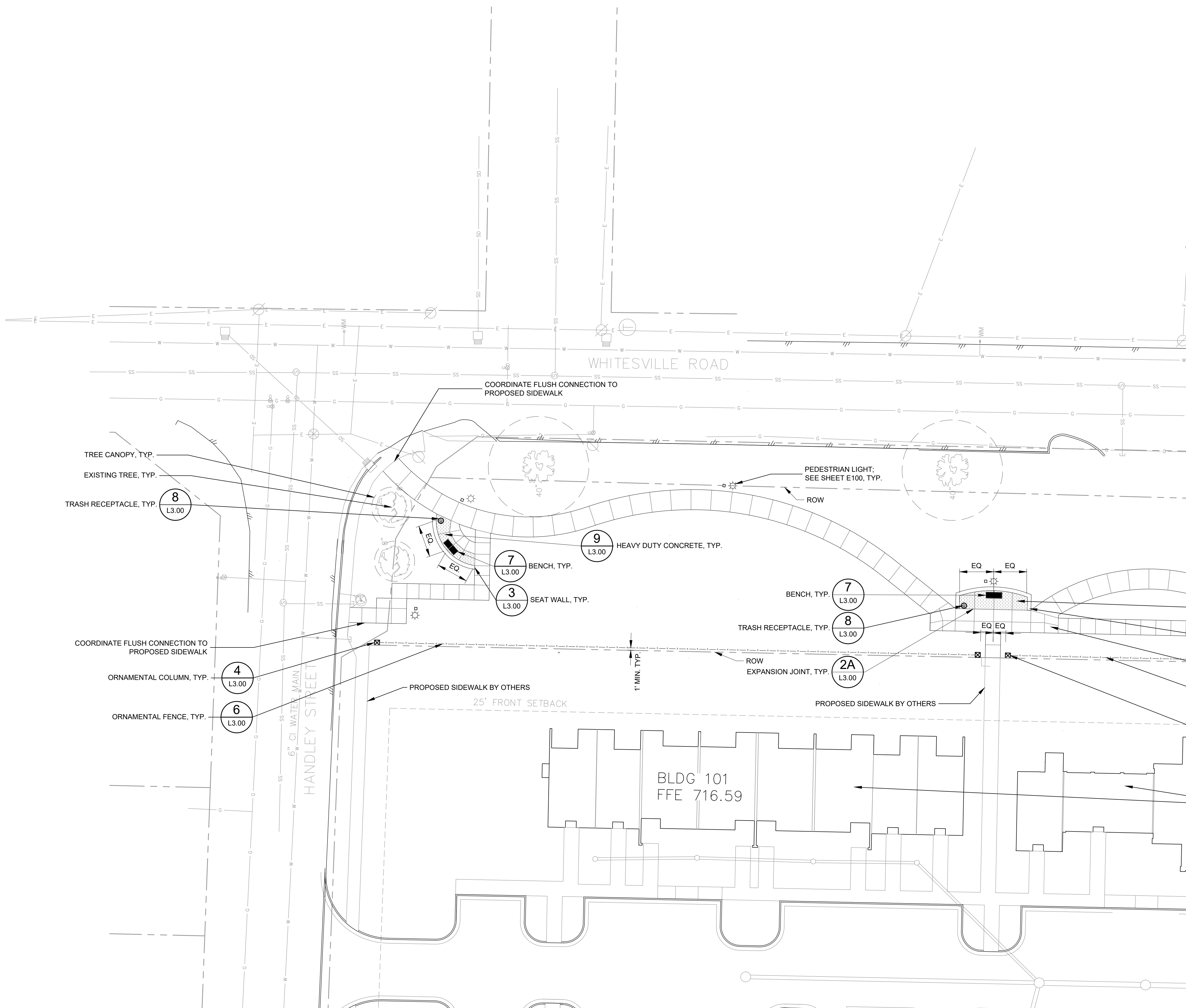

NOTES:

1. SEE SHEET L1.00 FOR GENERAL NOTES AND SITE AMENITIES SCHEDULE
2. SEE SHEET L3.00 FOR SITE DETAILS

BARGE
 DESIGN SOLUTIONS

1201 Front Avenue // Suite F // Columbus, GA 31901
 Phone (706) 321-1690



SITE MATERIALS PLAN
 CITY OF LAGRANGE
 BENJAMIN HILL
 LINEAR PARK
 LAGRANGE, GEORGIA

MATCH LINE - SEE SHEET L1.02

- 9 L3.00 HEAVY DUTY CONCRETE, TYP.
- 3 L3.00 SEAT WALL, TYP.
- 1 L3.00 CONCRETE WALK, TYP.
- 6 L3.00 ORNAMENTAL FENCE, TYP.; PLACEMENT TO BE CENTERED ON COLUMN
- 4 L3.00 ORNAMENTAL COLUMN, TYP.

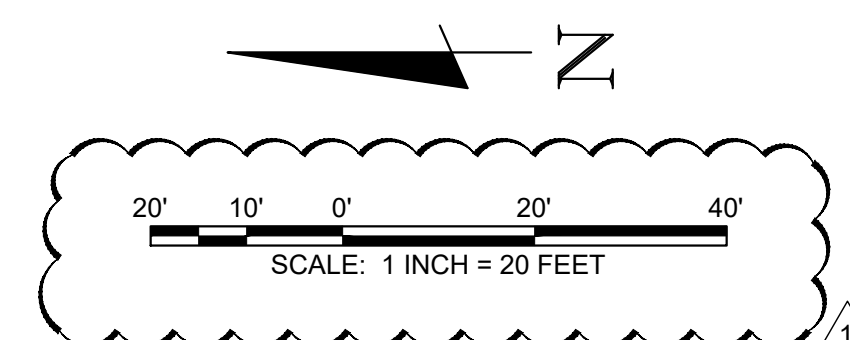

REVISION INFORMATION	
REV.	DESCRIPTION
1	INITIAL ISSUE
2	ADDENDUM NO. 1

L1.01
 PROJ. NO. 3643207

USER:LELOVE
 FILE: \\36\3643207\04_CAD\LAND\PI\6163\3643207L1.01.dwg
 SAVED: 4/19/2021
 PLOTTED: 5/12/2021

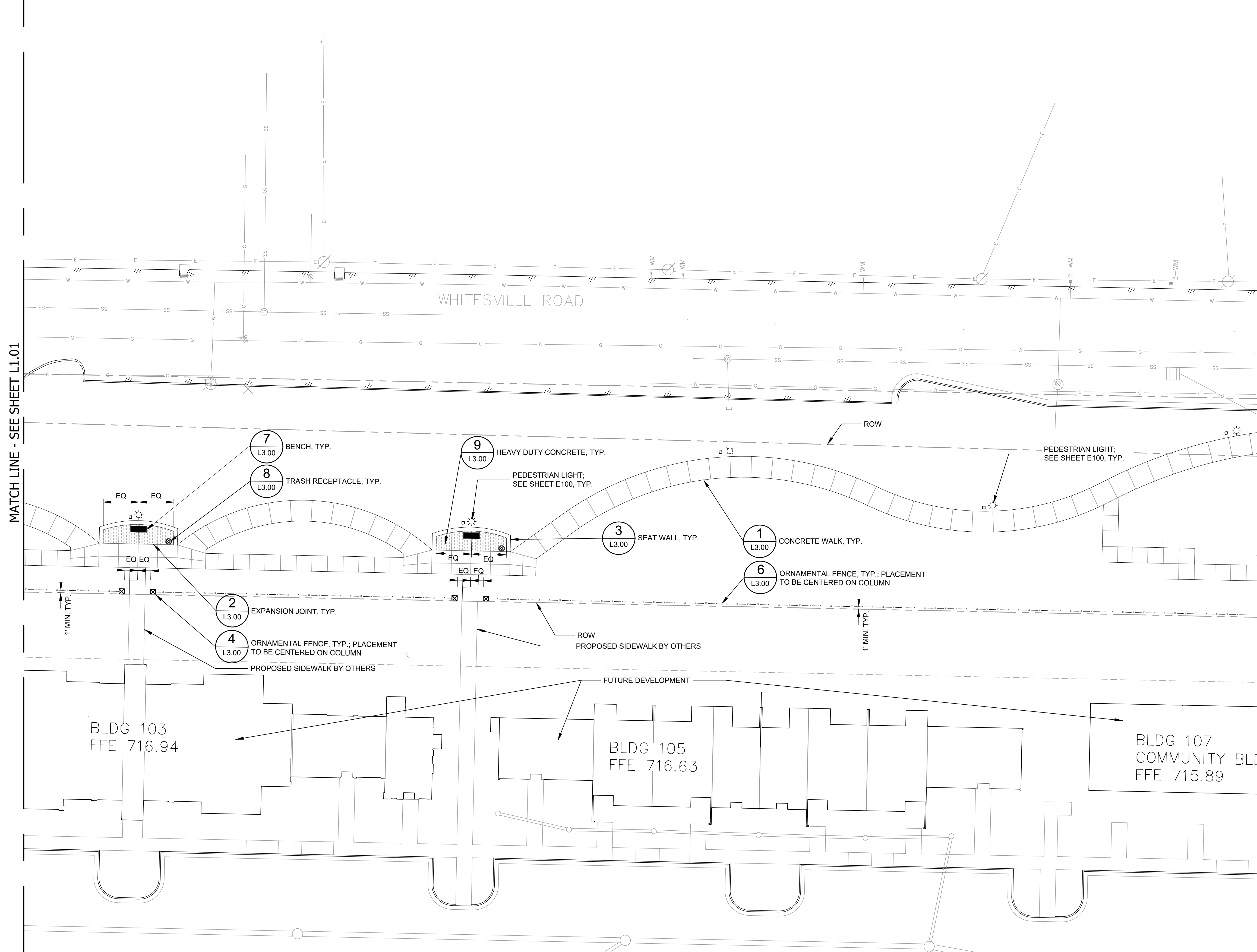

- NOTES:**
- SEE SHEET L1.00 FOR GENERAL NOTES AND SITE AMENITIES SCHEDULE
 - SEE SHEET L3.00 FOR SITE DETAILS



SITE MATERIALS PLAN
 CITY OF LAGRANGE
 BENJAMIN HILL
 LINEAR PARK
 LAGRANGE, GEORGIA

REVISION INFORMATION		DATE	DESCRIPTION
REV.	DR.	CHK.	DATE
1	LJL	JS	05-12-21
			INITIAL ISSUE
			ADDENDUM NO. 1

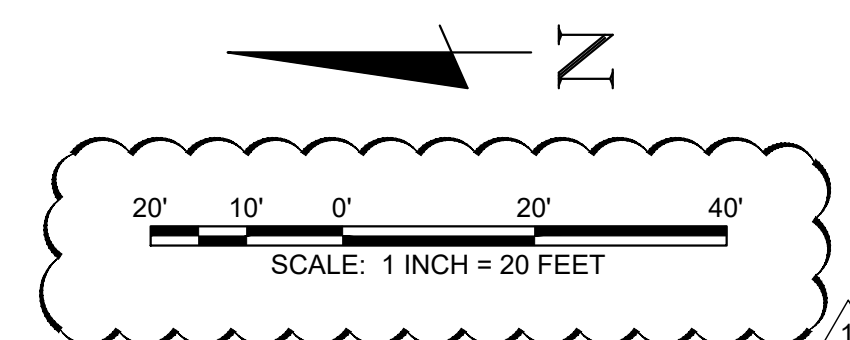

L1.02
 PROJ. NO. 3643207



SITE MATERIALS PLAN
CITY OF LAGRANGE
BENJAMIN HILL
LINEAR PARK
LAGRANGE, GEORGIA

NOTES:

- SEE SHEET L1.00 FOR GENERAL NOTES AND SITE AMENITIES SCHEDULE
- SEE SHEET L3.00 FOR SITE DETAILS

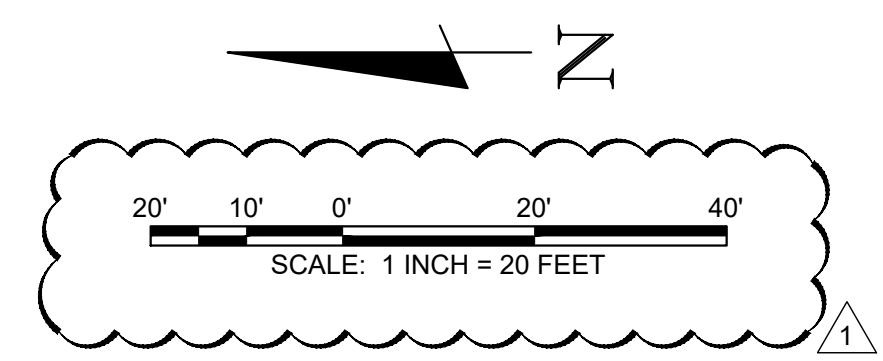
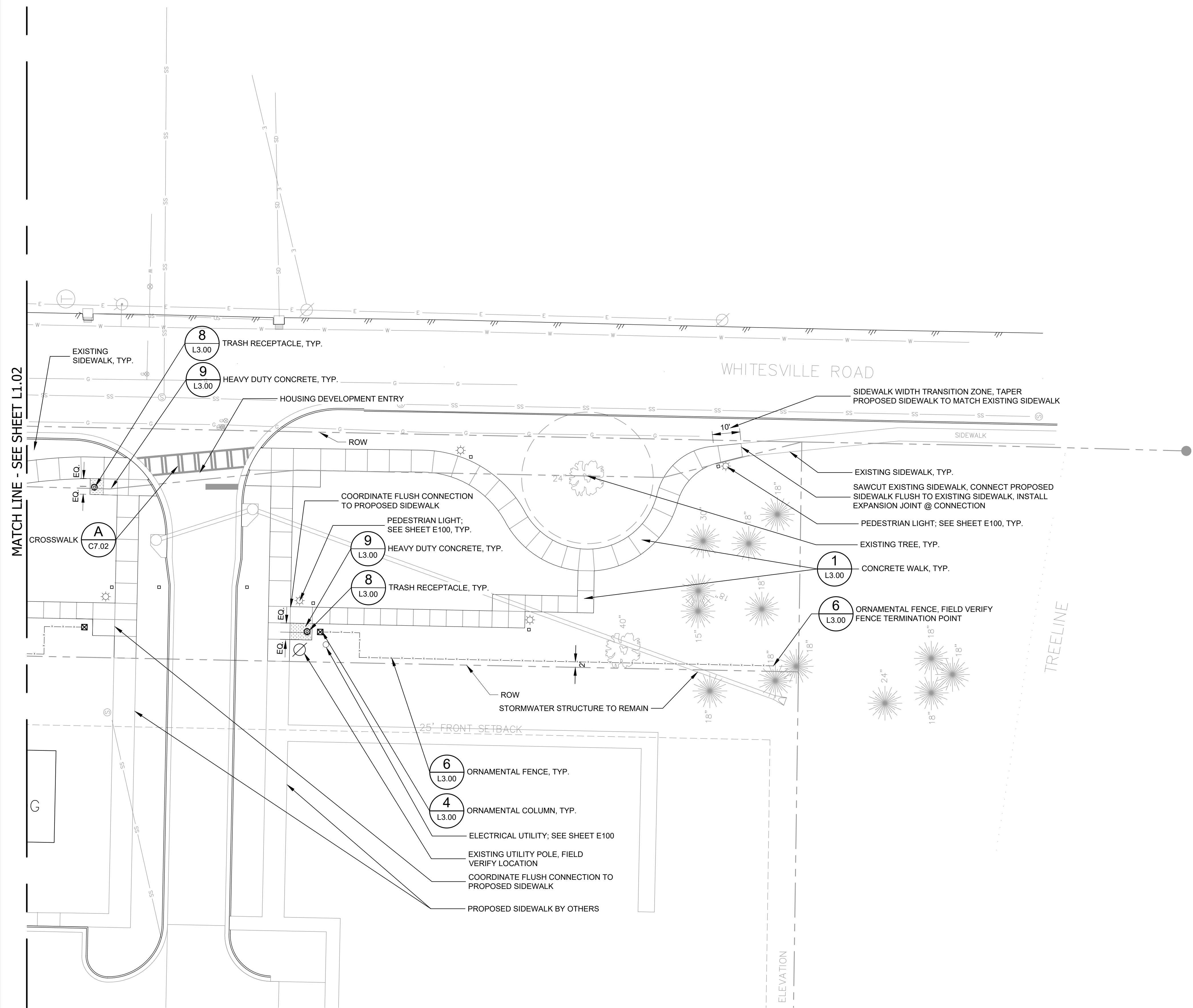

REVISION INFORMATION		DATE	DESCRIPTION
REV.	CHK.	DATE	DESCRIPTION
1	JS	05-12-21	ADDDENDUM NO. 1

L1.03
PROJ. NO. 3643207