

1 TYPICAL CONCRETE PAVING SECTION  
C2.1 NOT TO SCALE

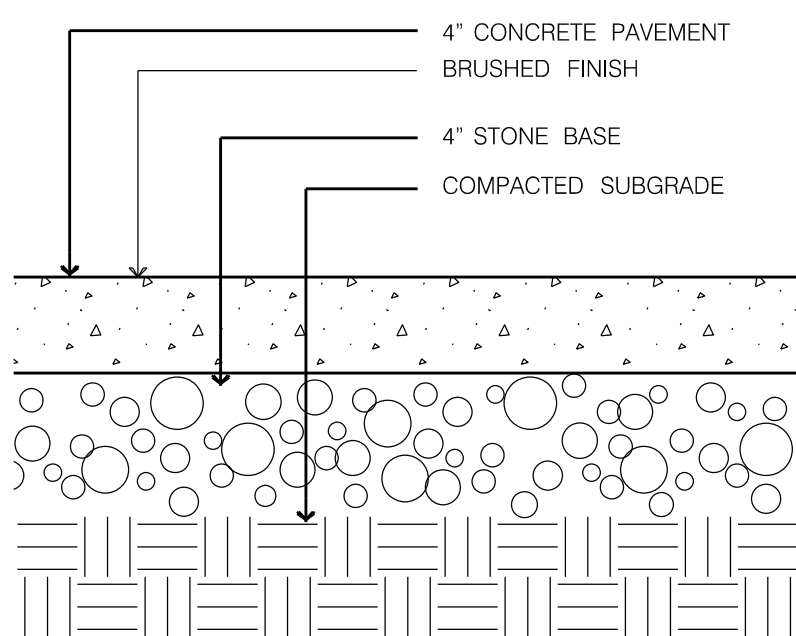

2 TYPICAL SIDEWALK SECTION  
C2.1 NOT TO SCALE

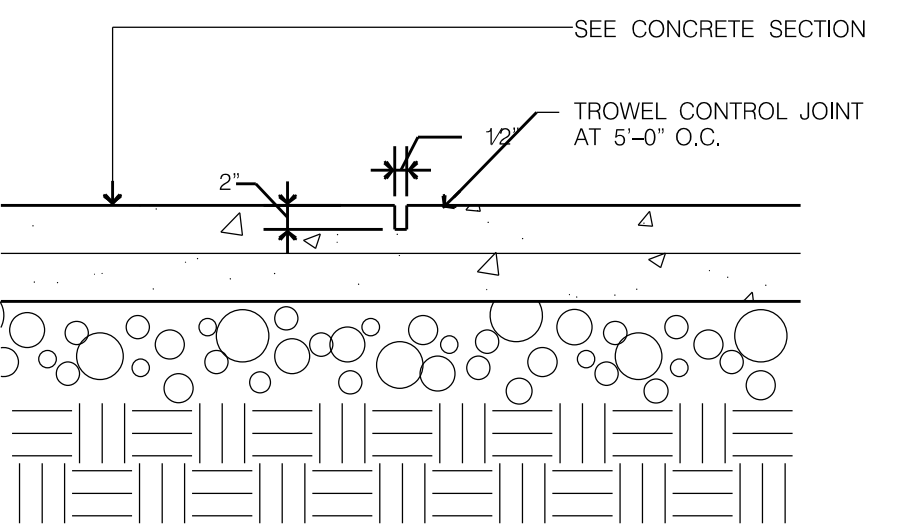

3 CONTROL JOINT DETAIL  
C2.1 NOT TO SCALE

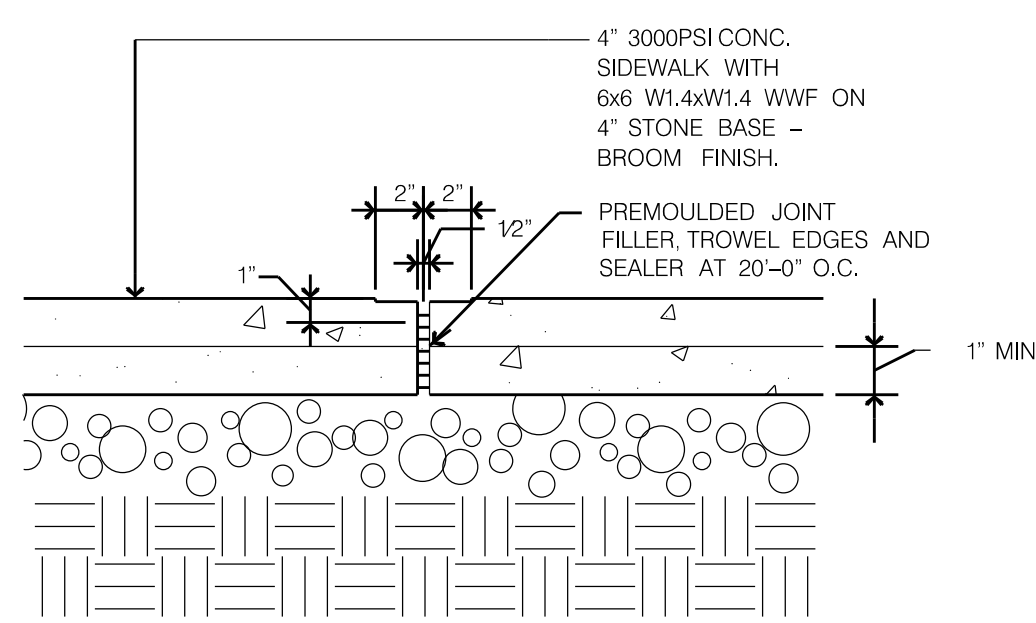

4 EXPANSION JOINT DETAIL  
C2.1 NOT TO SCALE

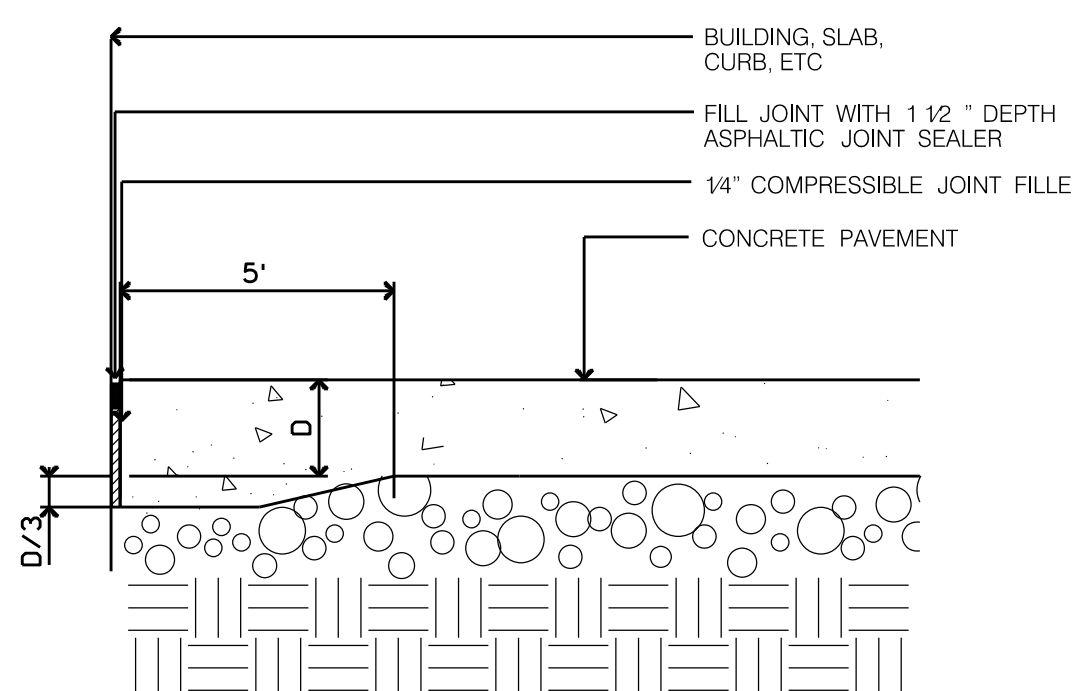

5 THICKENED EDGE DETAIL  
C2.1 NOT TO SCALE

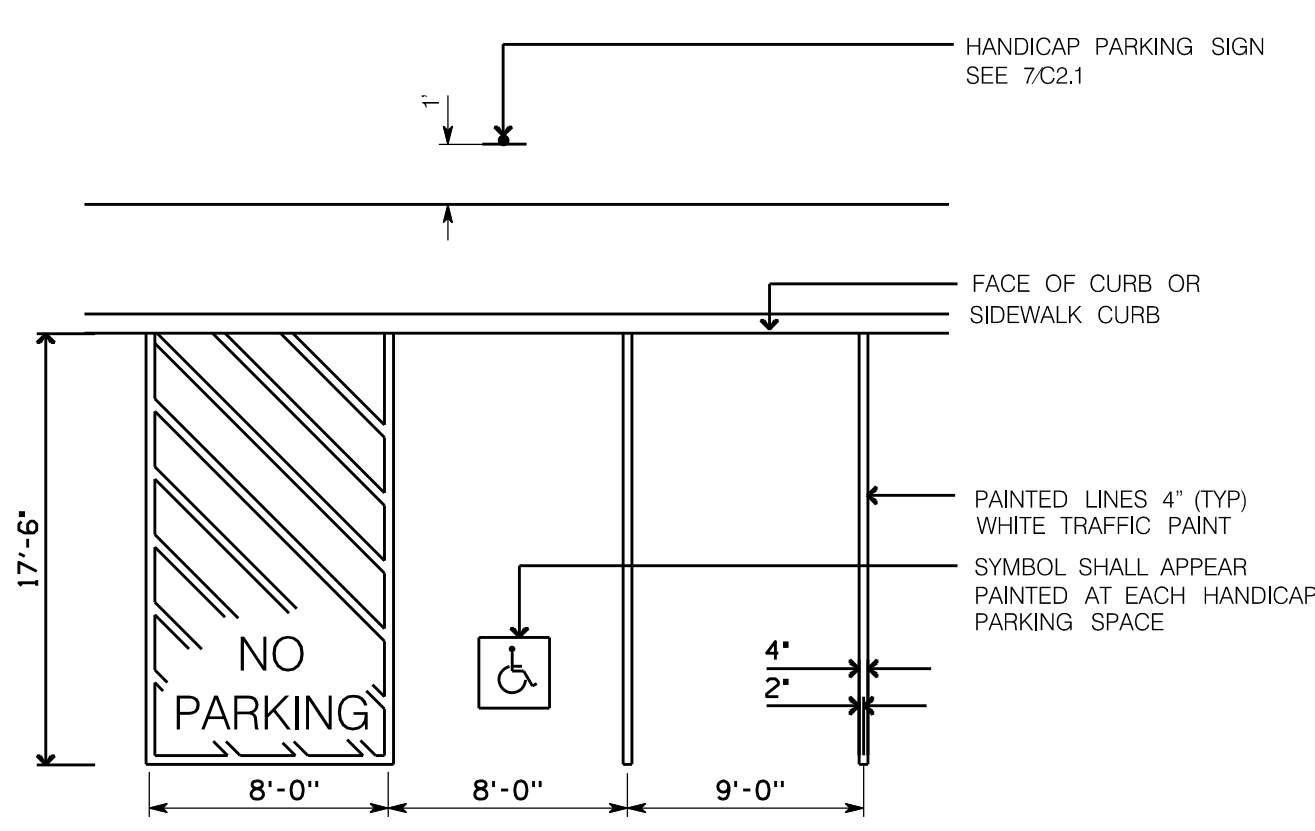

6 TYPICAL PARKING SPACE DETAIL  
C2.1 NOT TO SCALE

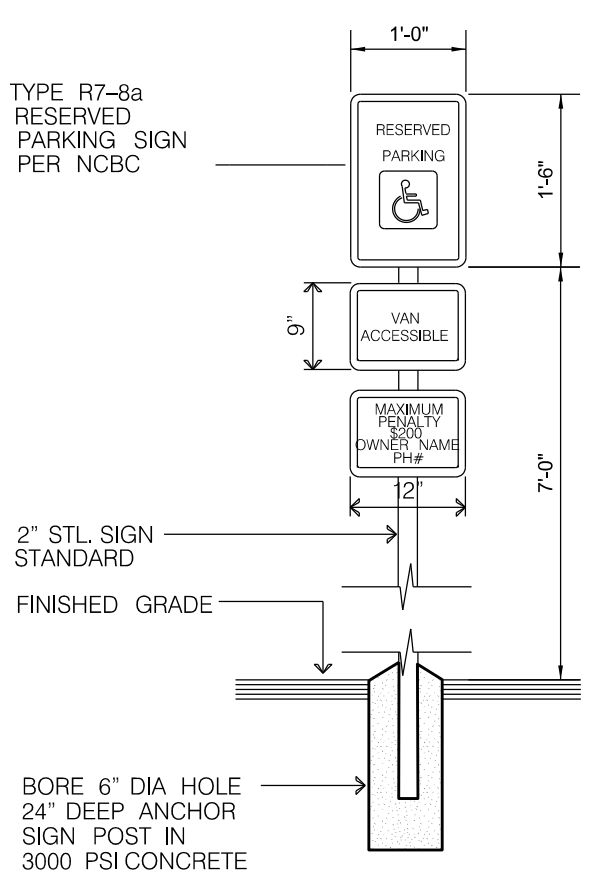

7 HANDICAP SIGN  
C2.1 NOT TO SCALE

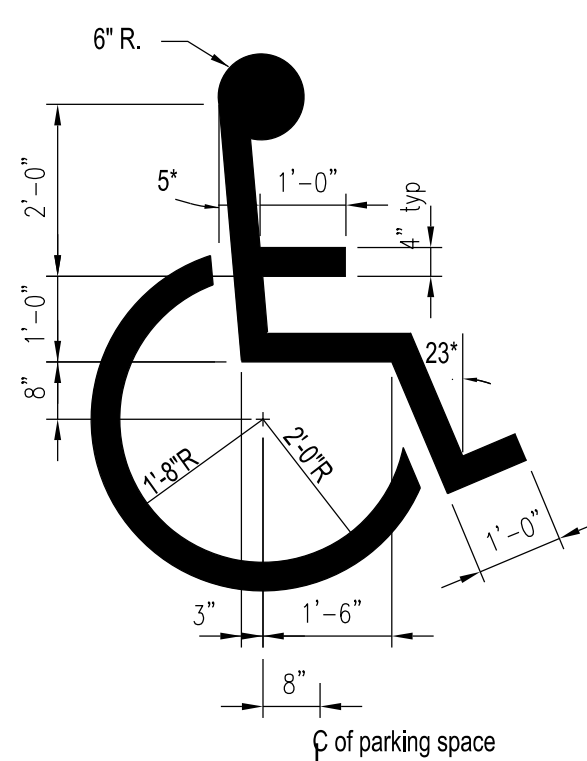

8 ACCESSIBILITY SYMBOL  
C2.1 NOT TO SCALE

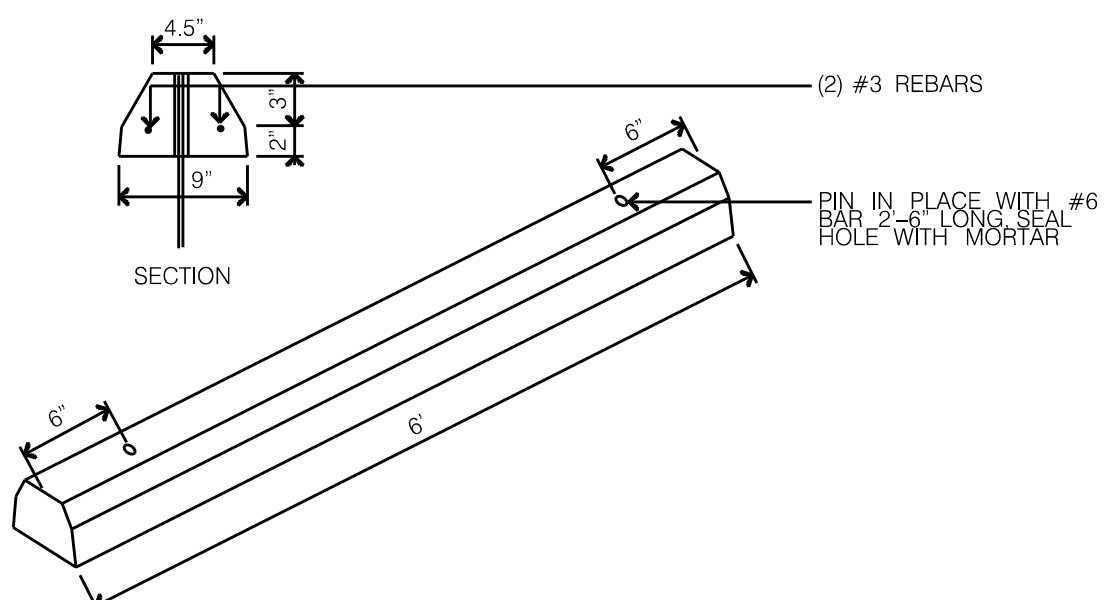

9 PRECAST CONCRETE WHEEL STOP  
C2.1 NOT TO SCALE

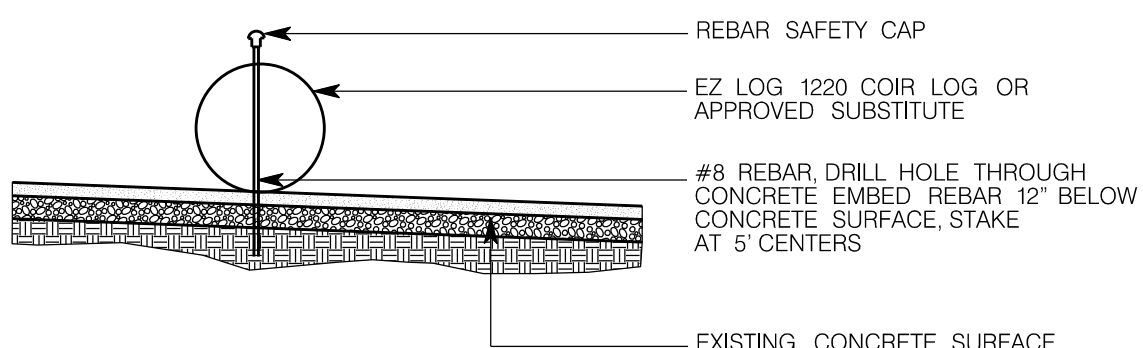

10 COIR LOG DETAIL  
C2.1 NOT TO SCALE

**WILL ROBINSON  
& ASSOCIATES**

1248 N. Shorewood Ln  
Caryville, TN 37714  
(865) 386-4200  
wrassociates@bellsouth.net

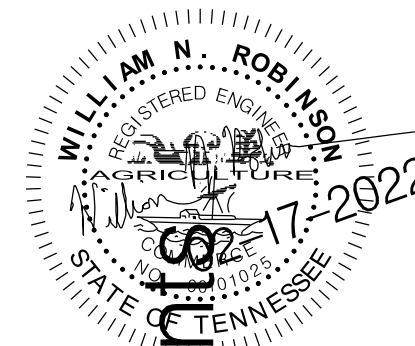

ADA Improvements to:  
**Cagle Terrace Apartments**

515 Renford Rd  
Knoxville, Tennessee

REVISIONS:

DRAWN: WNR  
CHECKED: WNR  
DATE: 02-17-2022  
FILE NAME:  
PROJECT NO:

**C2.1**  
SITE DETAILS - 1  
DRAWING