

**ADDENDUM NUMBER THREE**

**RESPONSE TO BIDDER'S REQUEST FOR INFORMATION  
BROWNFIELD CLEANUP AT THE FORMER GLOVER TRACT – RIVERWALK TRAIL  
FOR THE CITY OF CHATTANOOGA, TENNESSEE  
Contract Number D-17-008-201**

**RFI #1:**

*How are stations 4+00-8+00 being dealt with? While making a site visit we noticed the area had a soft sub-grade and is low, which poses a stability issue. The sewer manhole appears to be an overflow and has been discharging raw sewage for a substantial amount of time. How is the contractor to address this?*

Response:

If soft or unstable soils are encountered during construction, no undercutting or excavation shall take place. Geotextile Type IV and TDOT Class B riprap will be placed at the direction of the Engineer. See Addendum #3.

The Moccasin Bend WWTP has visited the site and determined that regular overflows are not occurring. However, any overflows or flooding from large rain events will result in a rain delay and the contractor will return after conditions at the site have stabilized.

**RFI #2:**

*Roller compacted concrete (RCC) minimum paving width is 11'. Will the trail be acceptable 11' width through its entirety if RCC is the best option?*

Response:

Stations 2+00 through 4+00 must be 8 feet in width to minimize the impact to the wetland. An alternate method to place concrete on this section of trail, such as a narrow width paver, shall be used. Other methods may be used if approved by the Engineer.

**RFI #3**

*When modeling the scope of work the 60 day duration seems to be insufficient. Will there be considerations to lengthen the project duration?*

Response: The City is currently looking into a project extension. A contract extension will be considered after contract award.

**RFI #4**

*Where in the bid schedule does the contractor absorb export cost or is all soils to be dispersed amongst site? Keep in mind we have identified areas that in are professional opinion will need undercuts.*

Response:

See response to RFI #1.

The following changes shall be incorporated into the requirements for the above referenced project:

I. BIDDING AND CONTRACTING DOCUMENTS

a. Section 00301 Bid Schedule

i. Added Item #13 – Rip Rap TDOT Class B

ii. Added Item #14 – Geotextile Type IV

II. PLANS

a. Drawing C501: Added “Detail – Trail Stabilization”

May 24, 2019

---

/s/Justin C. Holland, Administrator  
City Of Chattanooga  
Department of Public Works

**Bid Schedule**  
**City of Chattanooga**  
**Brownfield Cleanup at the Former Glover Tract - Riverwalk Trail**

Item No.	Description	Units	Est. No. of Units	Bid Unit Price	Bid Price
<b>Earthwork</b>					
1	Transport and Placement of Fill including excavation, loading, and redressing at the fill stockpile located at 3501 Central Ave Chattanooga TN	CY	1500		
2	Removal of vegetation to include herbicide, tree removal, and clearing within work limits as indicated on the Drawings	LS	1		
<b>Slope Protection and Erosion Control</b>					
3	Type "A" silt fence, complete-in-place, as required or directed by the engineer	LF	1,500		
4	Stream by-pass pump around	LS	1		
5	Temporary Construction Entrance	EA	2		
<b>Concrete</b>					
6	Roller Compacted Concrete (6 inches)	CY	640		
7	TDOT Approved Mineral Aggregate Base (plus fine grading)	CY	710		
<b>Culverts</b>					
8	6" dia. smooth steel pipe, 1/4" thickness, length varies (see Drawings)	EA	38		
9	Precast Concrete Box Culvert (4'h x 5'w) including TDOT approved granular foundation and filter fabric	LF	30		
10	Precast Concrete Endwalls	EA	2		
<b>Misc. (trail entrance at Workman Rd)</b>					
11	Mountable curb island	LF	25		Deleted
12	Removable Steel Bollards	EA	3		
<b>Trail Stabilization (placed as needed at the direction of the Engineer)</b>					
13	Rip Rap TDOT Class B	TON	245		
14	Geotextile Type IV	SY	650		
<b>Total of All Unit Price Bid Items (Base Bid)</b>					
<b>ALT (Required): Asphalt Surface (in lieu of items 6 and 7)</b>					
a	Asphaltic Concrete Binder (2.5 inches)	CY	270		
b	Asphaltic Concrete Surface (1.5 inches)	CY	160		
c	TDOT Approved Mineral Aggregate Base (8 inches) plus fine grading	CY	940		
<b>Alternate Total</b>					
<b>ADD ALT (Required): Concrete Sidewalk (5' wide) installed and in-place including handicap ramp, bike ramp, curbs, tactile pavers, all formwork, base stone, and reinforcement as indicated on the Drawings in addition to the removal of existing sidewalk and curb. See detail Sheet C107.</b>		<b>LS</b>	<b>1</b>		

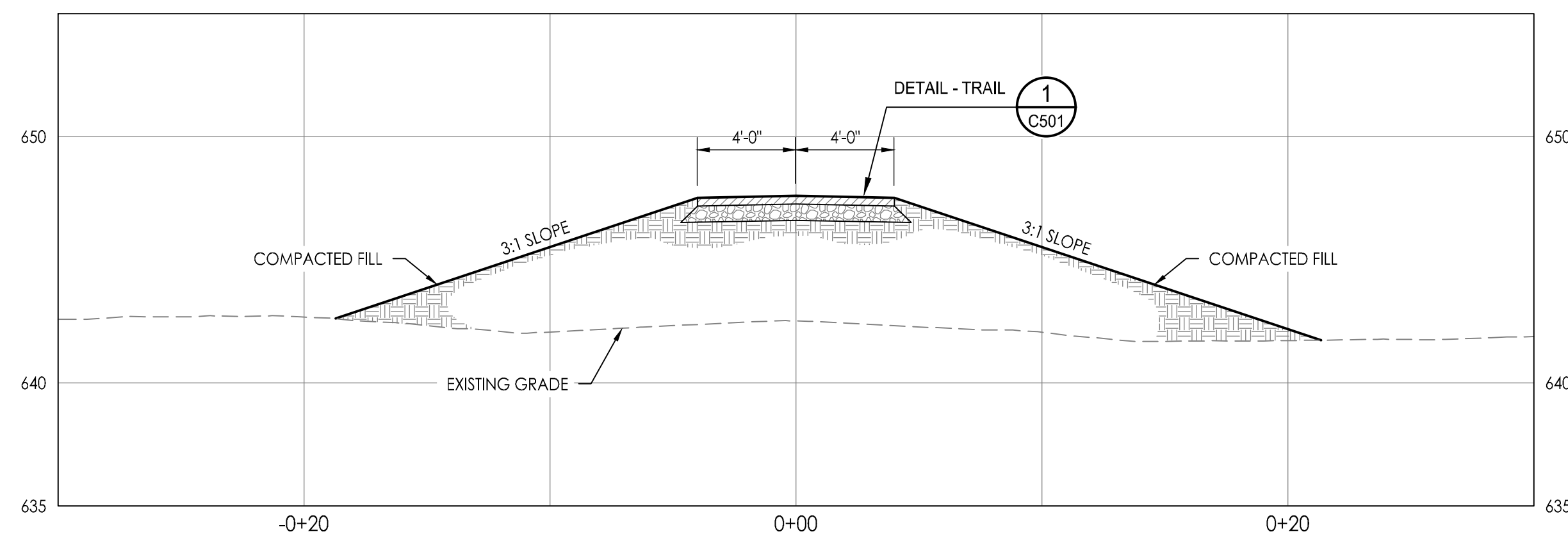

**A** SECTION A-A  
C101  
1"=5'  
0 5' 10'

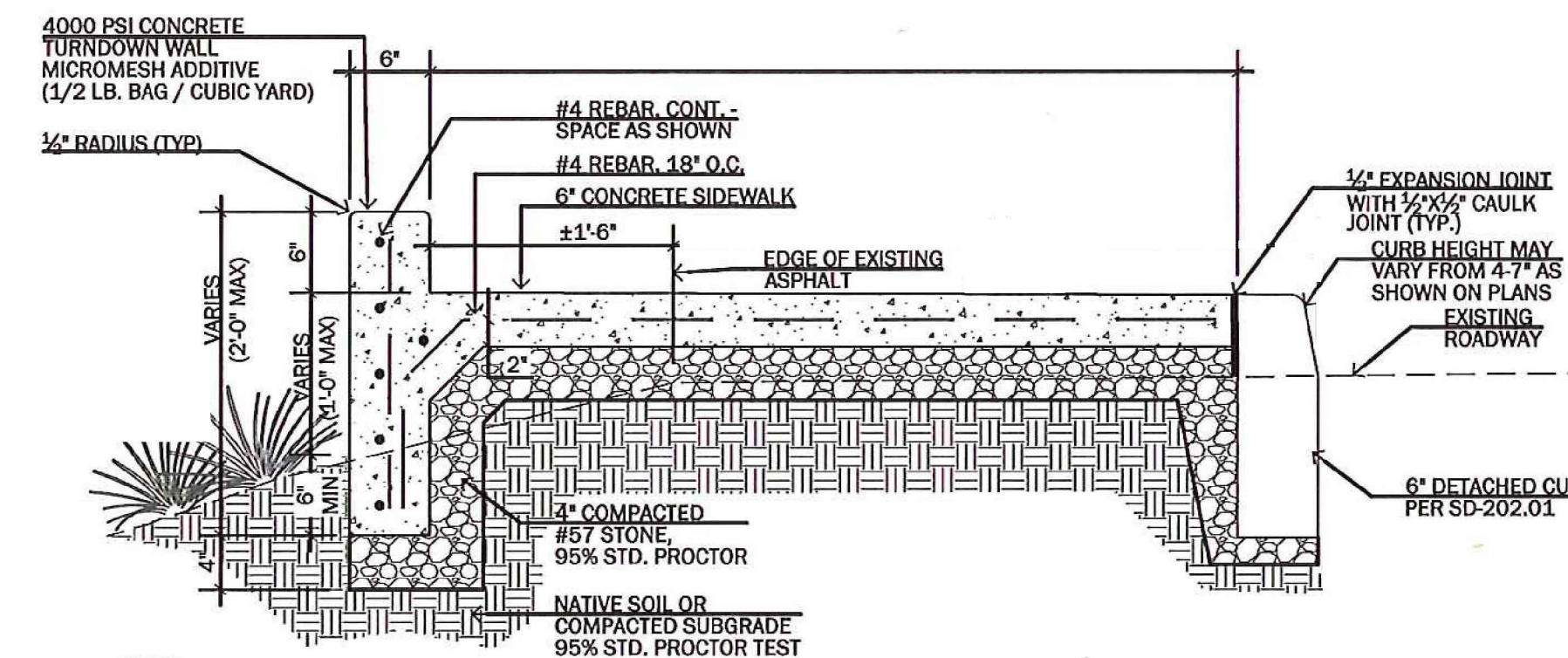

- NOTES:**
- THE ADJACENT EXISTING SURFACE VARIES PER PLANS. REFER TO DRAWINGS FOR LOCATIONS AND MATERIALS.
  - WALL HEIGHTS VARY PER LOCATION BUT SHALL NOT EXCEED 18" ABOVE ADJACENT SURFACE. THE CONTRACTOR SHALL NOTIFY THE OWNER'S REPRESENTATIVE IF HEIGHT DIFFERENTIALS EXCEED THOSE SHOWN.
  - THE CONTRACTOR SHALL INCLUDE #57 STONE, REINFORCEMENT, AND ALL NECESSARY FORM WORK WITHIN THE COST FOR CONCRETE SIDEWALK.

**B** SECTION B-B  
C107  
N.T.S.

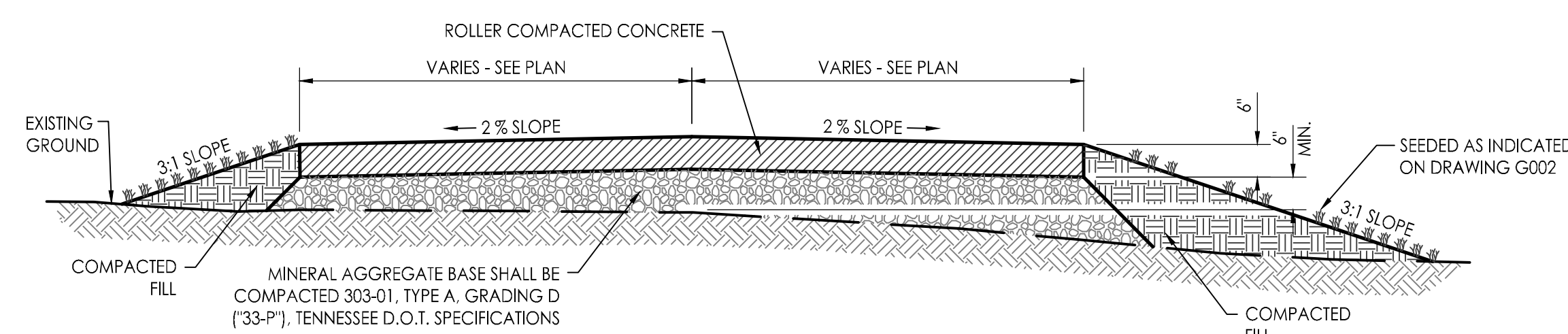

**1** DETAIL - ROLLER COMPACTED CONCRETE TRAIL  
1/2"=1'

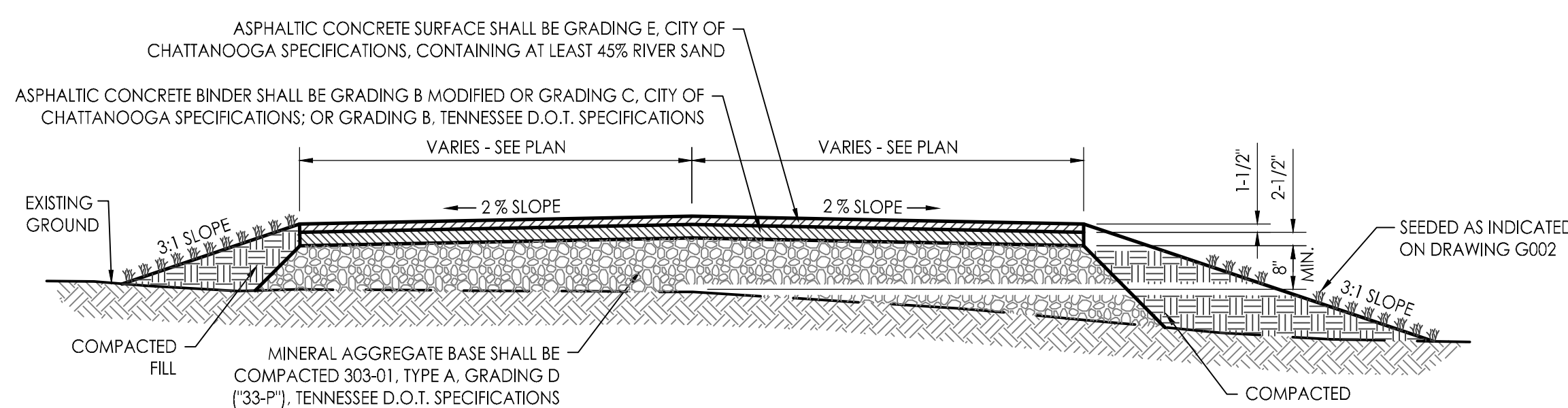

**1** DETAIL - ASPHALT TRAIL (ALTERNATE)  
1/2"=1'

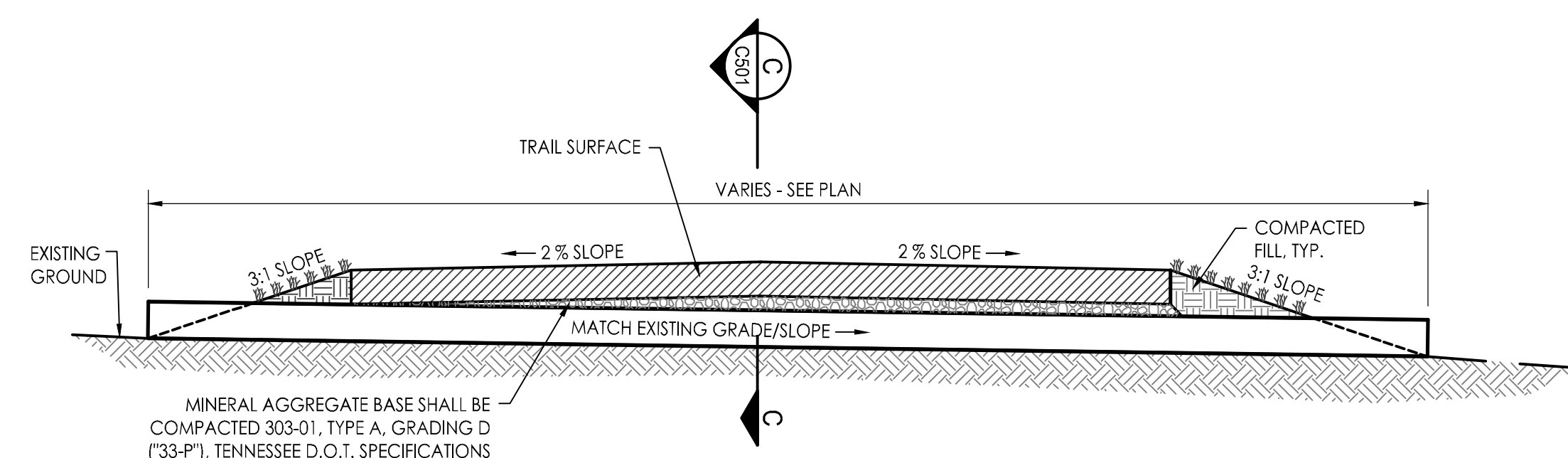

**2** DETAIL - 6" DIAMETER STEEL PIPE  
1/2"=1'

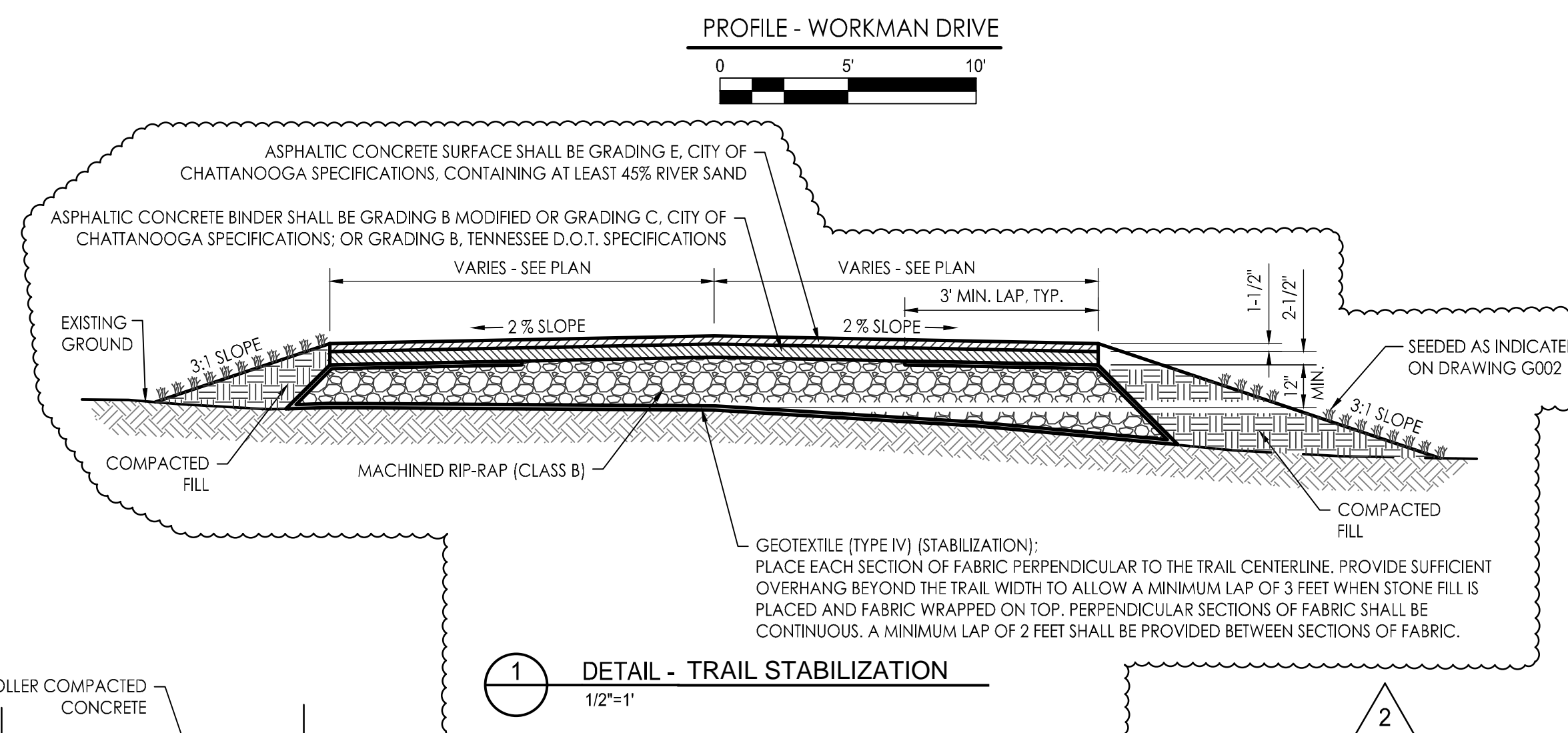

PROFILE - WORKMAN DRIVE  
0 5' 10'

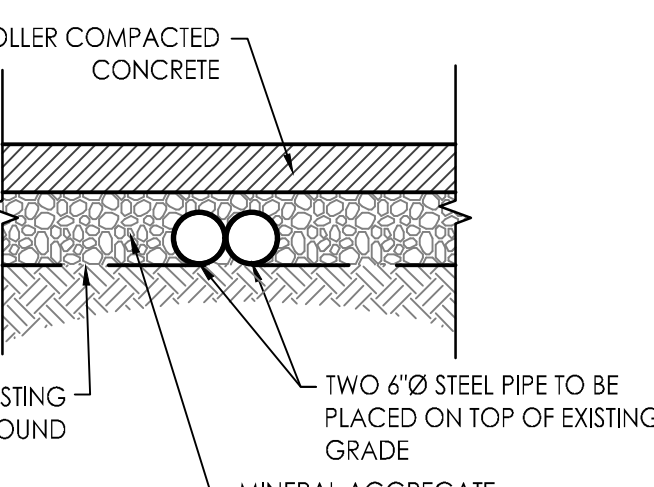

**C** SECTION - 6" DIAMETER STEEL PIPE  
C501  
1/2"=1'

Revision	By	App'd	YYYY.MM.DD
2	JFB	MWA	2019.05.28
1	JFB	MA	2019.05.13
0	MWA	JS	2019.04.19

File Name: 18801C-501-DT  
Dwn. JFB Dsgn. MWA LP Chkd. 2019.04.19  
YYYY.MM.DD

Permit/Seal

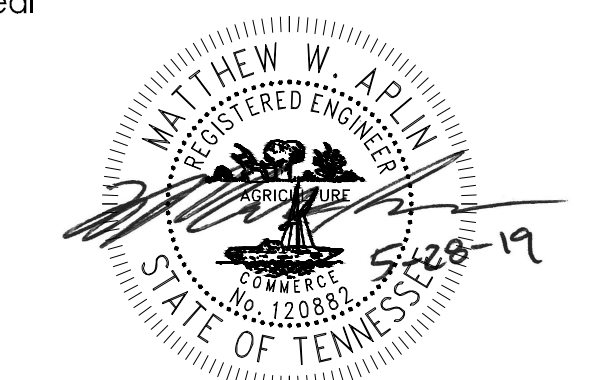

Client/Project Logo



Client/Project  
CITY OF CHATTANOOGA

BROWNFIELD CLEANUP AT THE FORMER  
GLOVER TRACT - RIVERWALK TRAIL  
CHATTANOOGA, TN

Title  
DETAILS, SECTIONS AND WORKMAN  
DRIVE PROFILE

Project No. 175618801	Scale AS NOTED
Revision Sheet 2 10 of 11	Drawing No. <b>C501</b>