ADDENDUM NUMBER ONE
TO THE CONTRACT DOCUMENTS FOR CONSTRUCTION OF
ORANGE BEACH RECREATION COMPLEX NEW GYMNASIUM
CITY OF ORANGE BEACH

Bid Date / Time: Thursday, March 14th at 11 am Central local time.

This addendum forms a part of the Contract Documents and modifies the Bid Documents dated February 18, 2018.

This Addendum consists of one (1) page Addendum, one (1) page Current Bidders list, two (2) Specifications & three (3) full-size sheets.

GENERAL

ITEM 01 Current Bidders List
Please see the attached bidders list.

SPECIFICATIONS

ITEM 01 SECTION 001113 – C-1 ADVERTISEMENT FOR BIDS
Add New Specification in its entirety.

ITEM 02 SECTION 133419 – METAL BUILDING SYSTEM
Add New Specification in its entirety.

DRAWINGS

ITEM 01 SHEET A3.01 – EXTERIOR ELEVATIONS
Reissue Sheet in its entirety.
1. Revise Legend – Exterior Materials and Fabrications

ITEM 02 SHEET S1.02 – TYPICAL DETAILS
Reissue Sheet in its entirety.
1. Revised Column footing Detail

ITEM 03 SHEET S2.01 – FLOOR PLANS
Reissue Sheet in its entirety.
1. Revised foundation floor plan and pedestal schedule

END OF ADDENDUM



**ORANGE BEACH RECREATION COMPLEX
NEW GYMNASIUM
CURRENT PRE-BID BIDDER'S LIST**

Thursday, March 14, 2019

11:00 AM

KNOWN BIDDER'S LIST:

THE HIGHLAND GROUP - (Ryan Long, rlong@highlandgroup.org)

P: [\(888\) 585-8564](tel:(888)585-8564)

TRIP TEK CONSTRUCTION, LLC - (Miles Smith, miltes@triptekllc.com)

P: [\(251\) 583-1170](tel:(251)583-1170)

GATES CONSTRUCTION – (Ken Gates, kengates@gatesbuilders.com)

P: [\(251\) 233-3029](tel:(251)233-3029)

STUART CONSTRUCTION – (Ben Harris, bharris@stuartcontracting.com)

P: [\(251\) 421-9175](tel:(251)421-9175)

ADVERTISEMENT FOR BIDS

Sealed proposals will be received by the City of Orange Beach at the office of the City Clerk located at Orange Beach City Hall 4099 Orange Beach Blvd Orange Beach, AL 36561 until 2:00 PM, CST March 21, 2019 for

PROJECT: ORANGE BEACH RECREATION COMPLEX NEW GYMNASIUM
CITY OF ORANGE BEACH
Resolution No. 18-167

at which time and place they will be publicly opened and read. General Contractor's License number and type must be on the envelope.

A cashier's check or bid bond payable to City of Orange Beach in an amount not less than five (5) percent of the amount of the bid, but in no event more than \$10,000.00, must accompany the bidder's proposal. Performance and Payment Bonds and evidence of insurance required in the bid documents will be required at the signing of the Contract.

Bid Drawings and specifications will be available and can be examined at the office of the Architect on and after February 26, 2019.

Name of Architect: Jim Hartsell / Jeff Menasco
Name of Company: Davis Architects, Inc.
Address: 120 Twenty Third Street South, Birmingham, Alabama 35233
Phone No.: (205) 322-7482 Fax No.: (205) 322-7485

Bid Documents can also be reviewed at F.W. Dodge Plan Rooms, Construction Market Data Plan Room and obtained from Alabama Graphic Digital Plan Room. Cost of printing plans and specifications are non-refundable.

General Contractor Bidders may obtain a digital copy of the documents from Davis Architects, Jeff Menasco - jmensaco@dadot.com. Also, hard copy sets of drawings and specifications will be available to qualified General Contractors and others for the cost of printing and handling directly from the documents printer: Alabama Graphics (2801 Fifth Avenue South, Birmingham, Alabama 35233; phone 205/252-8505). Addenda and other bidding information will be issued only to holders of drawings and specifications distributed by the Architect. Release of the Bid Documents to the bidder does not imply acceptance of the bidder's qualifications by the Owner or Architect.

Bids must be submitted on proposal forms furnished by the Architect or copies thereof. All bidders bidding in amounts exceeding that established by the State Licensing Board for General Contractors must be licensed under the provisions of Title 34, Chapter 8, Code of Alabama, 1975, and must show evidence of license before bidding or bid will not be received or considered by the Architect; the bidder shall show such evidence by clearly displaying his or her current license number on the outside of the sealed envelope in which the proposal is delivered. The Owner reserves the right to reject any or all proposals and to waive technical errors if, in the Owner's judgment, the best interests of the Owner will thereby be promoted.

Nonresident bidders must accompany any written Bid Documents with a written opinion of an attorney at law licensed to practice law in such nonresident bidder's state or domicile, as to the preferences, if any or none, granted by the law of that state to its own business entities whose principal places of business are in that state in the letting of any or all public contracts.

A Pre-Bid Conference will be held at the City of Orange Beach at the office of the City Clerk located at Orange Beach City Hall, 4099 Orange Beach Blvd Orange Beach, AL 36561 at 11:00 A.M. Thursday, March 14, 2019. **Attendance by General Contractor Bidders at Pre-Bid Conference is mandatory.**

Awarding Authority:
City of Orange Beach
Ken Grimes, Jr., City Administrator

Architect:
McCollough Architecture: Sted McCollough, President

Davis Architects: Jim Hartsell, Vice President / Jeff Menasco, Project Architect

ALL BIDS MUST BE RETURNED AS FOLLOW:

All bidders must use the bid form provided in the bid documents and show on the envelope "SEAL BID", the bid title, the bidder's name, and the opening date and time.

Mailed Bids via U.S. Postal Service

City of Orange Beach
Attention: City Clerk
P.O. Box 458
Orange Beach, AL 36561

Hand Delivered Bids

City of Orange Beach
Attention: City Clerk
4099 Orange Beach Blvd.
Orange Beach, AL 36561

The Birmingham News, Mobile Press-Register and Montgomery Advertiser Publication Dates:

1. March 3, 2019
2. March 10, 2019
3. March 17, 2019

**SECTION 13 3419
METAL BUILDING SYSTEMS**

PART 1 GENERAL

1.01 SECTION INCLUDES

- A. Provide complete metal building system including but not limited to:
 - 1. Design.
 - 2. Materials.
 - 3. Fabrication.
 - 4. Shipment.
 - 5. Erection.
 - 6. Other components as specified.
- B. Manufacturer-engineered, shop-fabricated structural steel building frame.
- C. Metal wall panels, metal roof panels, metal joist, metal beams, metal deck, metal gutters, metal downspouts, wall insulation system and roof insulation system.
- D. Interior wall liner panels where indicated; both at perimeter walls and interior partitions, and to include all necessary furring.

1.02 RELATED REQUIREMENTS

- A. Section 05 4000 - Cold Formed Metal Framing
- B. Section 05 5000 - Metal Fabrications.
- C. Section 05 5113 – Metal Pan Stairs
- D. Section 06 6100 - Rough Carpentry: Wood blocking and nailers.
- E. Section 07 9200 - Joint Sealants: Sealing joints between accessory components and wall system.
- F. Section 08 1113 - Hollow Metal Doors and Frames.
- G. Section 09 9600 - High Performance Coatings: Metal building structural framing and bracing
- H. Section 11 6623 - Gymnasium Equipment: Equipment to be hung from structure.
- I. Section 11 6643 - Interior Scoreboards: Equipment to be hung from structure.
- J. Section 11 6653 - Gymnasium Dividers: Equipment to be hung from structure.

1.03 DEFINITIONS

- A. Code: The word "code" refers to the Building Code.
- B. Installer, Erector or Applicator:
 - 1. Installer, erector or applicator is the person actually installing, erecting or applying the product in the field at the Project site.
 - 2. Installer, erector and applicator are synonymous.
- C. PVDF: Polyvinylidene fluoride.
 - 1. Nomenclature as listed in Bibliography of the MBMA Low Rise Building Systems Manual.

1.04 REFERENCE STANDARDS

- A. AISC 303 - Code of Standard Practice for Steel Buildings and Bridges; 2016.
- B. AISC 360 - Specification for Structural Steel Buildings; 2016.
- C. ASHRAE Std 90.1 I-P - Energy Standard for Buildings Except Low-Rise Residential Buildings; 2013, Including All Amendments and Errata.
- D. ASTM A36/A36M - Standard Specification for Carbon Structural Steel; 2014.ASTM
- E. A153/A153M - Standard Specification for Zinc Coating (Hot-Dip) on Iron and Steel Hardware; 2016a.
- F. ASTM A307 - Standard Specification for Carbon Steel Bolts, Studs, and Threaded Rod 60 000 PSI Tensile Strength; 2014 (Editorial 2017).
- G. ASTM A500/A500M - Standard Specification for Cold-Formed Welded and Seamless Carbon Steel Structural Tubing in Rounds and Shapes; 2013.
- H. ASTM A501/A501M - Standard Specification for Hot-Formed Welded and Seamless Carbon Steel Structural Tubing; 2014.
- I. ASTM A529/A529M - Standard Specification for High-Strength Carbon-Manganese Steel of Structural Quality; 2014.
- J. ASTM A792/A792M - Standard Specification for Steel Sheet, 55% Aluminum-Zinc Alloy-Coated by the Hot-Dip Process; 2010 (Reapproved 2015).
- K. ASTM C665 - Standard Specification for Mineral-Fiber Blanket Thermal Insulation for Light Frame Construction and Manufactured Housing; 2012.
- L. ASTM C827/C827M - Standard Test Method for Change in Height at Early Ages of Cylindrical

- Specimens of Cementitious Mixtures; 2016.
- M. ASTM C920 - Standard Specification for Elastomeric Joint Sealants; 2014a.
 - N. ASTM C991 - Standard Specification for Flexible Fibrous Glass Insulation for Metal Buildings; 2016.
 - O. ASTM C1107/C1107M - Standard Specification for Packaged Dry, Hydraulic-Cement Grout (Nonshrink); 2014a.
 - P. ASTM F3125/F3125M - Standard Specification for High Strength Structural Bolts, Steel and Alloy Steel, Heat Treated, 120 ksi (830 MPa) and 150 ksi (1040 MPa) Minimum Tensile Strength, Inch and Metric Dimensions; 2015a. ding, Brazing, and Nondestructive Examination; 2012.
 - Q. AWS D1.1/D1.1M - Structural Welding Code - Steel; 2015 (with March 2016 Errata).
 - R. IAS AC472 - Accreditation Criteria for Inspection Programs for Manufacturers of Metal Building Systems; 2012.
 - S. ICC (IBC) - International Building Code; 2018.
 - T. ICC (IECC) - International Energy Conservation Code; 2018.
 - U. MBMA (MBSM) - Metal Building Systems Manual; 2012.
 - V. SSPC-Paint 20 - Zinc-Rich Primers (Type I, "Inorganic," and Type II, "Organic"); 2002 (Ed. 2004).
 - W. UL 580 - Standard for Tests for Uplift Resistance of Roof Assemblies; Current Edition, Including All Revisions.

1.05 ADMINISTRATIVE REQUIREMENTS

- A. Coordination:
 - 1. Coordinate the installation of wood blocking, bridging and nailers where necessary for attachment of equipment and other elements.
 - 2. Coordinate the installation of structural elements and components necessary for support and attachment of canopies, overhead doors and other elements requiring attachment to building structure.
 - 3. Coordinate primers for compatibility with proposed field-applied topcoats.
- B. Pre-installation Meeting: Convene one week before starting work of this section.
 - 1. Review preparation and installation procedures and coordinating and scheduling required with related work.
 - 2. Attendance: Architect, Building Commission Inspector, Owner's Insurer (if applicable), General Contractor, metal building manufacturer and metal building erector. If rooftop equipment is to be placed on roof, mechanical contractor shall also attend.
 - 3. Architect will prepare written report indicating actions taken, decisions made, and items discussed. Report will become a part of the record.
 - 4. Distribution: General Contractor (for further distribution to subcontractors); Owner.
- C. Project Record Documents: Record actual locations of concealed components and utilities.

1.06 SUBMITTALS

- A. See Section 01 3000 - Administrative Requirements, for submittal procedures.
- B. Product Data: Provide data on profiles, component dimensions, fasteners and energy code compliant roof and wall insulation systems.
- C. Shop Drawings: Indicate assembly dimensions, locations of structural members, connections; wall and roof system dimensions, panel layout, general construction details, anchorages and method of anchorage, installation, and structural bracing; Provisions for equipment and other building element loads to be hung from structure: framing anchor bolt settings, sizes, and locations from datum, foundation loads; indicate welded connections with AWS A2.4 welding symbols; indicate net weld lengths; provide professional seal and signature.
- D. Samples: Submit two samples of precoated metal panels for each color selected, 16 by 16 inch in size illustrating color and texture of finish.
- E. Manufacturer's Instructions: Indicate preparation requirements, anchor bolt placement, and foundation requirements.
- F. Erection Drawings: Indicate members by label, assembly sequence, and temporary erection bracing.
- G. Manufacturer Qualification Statement: Provide documentation showing metal building manufacturer is accredited under IAS AC472.
 - 1. Include statement that manufacturer designs and fabricates metal building system as integrated components and assemblies, including but not limited to primary structural members, secondary members, interior walls, raised floor systems, joints, roof, and wall cladding components specifically designed to support and transfer loads and properly assembled components form a complete or partial building shell.

H. Informational Submittals:

1. Manufacturer's and Erector's Qualifications.
2. Manufacturer's approval of erector.
3. Structural calculations stamped and signed by a professional Structural Engineer licensed in the State where Project is located.
 - i. Include list of design loads and loads transmitted to foundation through columns or walls and location where loads occur.
 - ii. Submit calculations for information only.
4. Certificate of compliance by fabricator that steel was fabricated in accordance with the approved construction documents.

I. Project Record Documents: Record actual locations of concealed components and utilities.

1.07 QUALITY ASSURANCE

- A. Design structural components, develop shop drawings, and perform shop and site work under direct supervision of a Professional Structural Engineer experienced in design of this Work.
 1. Design Engineer Qualifications: Licensed in the State in which the Project is located.
 2. Conform to applicable code for submission of design calculations as required for acquiring permits.
 3. Coordinate equipment loads with equipment manufacturers to support all applicable loads.
 4. Cooperate with regulatory agency or authority and provide data as requested.
- B. Perform work in accordance with ASHRAE 90.1 as applicable and MBMA (MBSM) and ICC (IBC).
- C. Perform welding in accordance with AWS D1.1/D1.1M.
- D. Manufacturer Qualifications: Company specializing in the manufacture of products similar to those required for this project.
 1. Not less than 5 years of documented experience
 2. Member in good standing of the MBMA.
 3. Accredited by IAS in accordance with IAS AC472.
- E. Erector Qualifications: Company specializing in performing the work of this section with minimum 10 years documented experience and approved by manufacturer.
 1. Installer's Field Supervisor: Experienced mechanic certified by metal building system manufacturer supervising work on site whenever work is underway.

1.08 WARRANTY

- A. See Section 01 7800 - Closeout Submittals, for additional warranty requirements.
- B. Correct defective Work within a five year period after Date of Substantial Completion.
- C. Provide 20 year manufacturer warranty for factory applied finishes and weather-tightness.
 1. Include coverage for exterior pre-finished surfaces to cover pre-finished color coat against chipping, cracking or crazing, blistering, peeling, chalking, or fading. Include coverage for weather tightness of building enclosure elements after installation.
- D. Special Installer's and General Contractor's Warranty: Submit roofing installer's and General Contractor's warranty, on warranty form ABC Form C-9 signed by installer and General Contractor, covering Work of this Section, including all components of membrane roofing system such as roof membrane, base flashings, roof insulation, adhesives and fasteners, cover boards, substrate boards, vapor retarders, roof pavers and walkway products for the following warranty period:
 1. Warranty Period: Five (5) years from date of Substantial Completion.
 2. Warranty Note: This shall not deprive the Owner of other rights the Owner may have under other provisions of the Contract Documents and shall be in addition to, and run concurrent with other warranties made by the Contractor under requirements of the Contract Documents.

PART 2 PRODUCTS

201 MANUFACTURERS

- A. Basis of Design Metal Building: MESCO Building Solutions: www.mescobuildingsolutions.com.
- B. Other Acceptable Metal Buildings:
 1. ACI Building Systems, LLC: www.acibuildingsystems.com.
 2. American Buildings Company: www.americanbuildings.com.
 3. Bigbee Steel Buildings Inc.: www.bigbee.com.
 4. Butler Manufacturing Company: www.butlermfg.com.
 5. Ceco Building Systems: www.cecobuildings.com.

6. Inland Buildings: www.inlandbuildings.com.
7. Nucor Building Systems: www.nucorbuildingsystems.com.
8. VP Buildings: www.vp.com.
9. Vulcan Steel Structures: www.vulcansteel.com.
10. Substitutions: See Section 01 6000 - Product Requirements.

202 METAL BUILDING

- A. Single and multi span rigid frame as indicated on Drawings. See Drawings.
- B. Exterior bay spacing: See Drawings.
- C. Interior bay spacing: See Drawings.
- D. Interior partition framing
- E. Primary Framing: Rigid frame of rafter beams and columns, canopy beams, intermediate columns, equipment platform beams, equipment platform joist, metal Joist, end wall columns, and wind bracing.
- F. Secondary Framing: Purlins, Girts, Equipment platform Metal Decking, Equipment Platform metal angles, Equipment platform metal channels, hat Channels (Max 7/8") at reverse roof paneling, Eave struts, Flange bracing, Sill supports, and Clips, and other items detailed in this specification or construction drawings.
- G. Wall System: Preformed metal panels of vertical profile, with sub-girt framing/anchorage assembly, insulation, liner sheets, and structural framing for canopies, and accessory components.
- H. Roof System: Preformed metal panels oriented parallel to slope, with sub-girt framing/anchorage assembly, insulation, and canopies where shown on Drawings, and accessory components.
- I. Roof Slope: 3 inches in 12 inches.

203 MATERIALS - FRAMING

- A. Structural Steel Members: ASTM A36/A36M.
- B. Structural Tubing: ASTM A500/A500M, Grade B cold-formed.
- C. Plate or Bar Stock: ASTM A529/A529M, Grade 50.
- D. Anchor Bolts: ASTM A307, galvanized to ASTM A153/A153M.
Bolts, Nuts, and Washers: ASTM F3125/F3125M, Type 1; galvanized to ASTM A153/A153M.
- E. Welding Materials: Type required for materials being welded.
- F. Primer: SSPC-Paint 20, zinc rich.
- G. Grout: ASTM C1107/C1107M; Non-shrink; premixed compound consisting of non-metallic aggregate, cement, water reducing and plasticizing agents.
 1. Minimum Compressive Strength at 48 Hours: 2,000 pounds per square inch.
 2. Minimum Compressive Strength at 28 Days: 7,000 pounds per square inch.
 3. Height Change, Plastic State; when tested according to ASTM C827/C827M:
 - a. Maximum: Plus 4 percent.
 - b. Minimum: Plus 1 percent.

204 MATERIALS - WALLS AND ROOF

- A. Steel Sheet: ASTM A792/A792M aluminum-zinc alloy coated to AZ50/AZM150.
- B. Basis of Design Roof Insulation System: Linear banded, filled cavity system with continuous vapor barrier below the purlins at roof construction and meeting the following levels of performance.
 1. R-5 thermal block on purlins; Not less than R-13 unfaced fiberglass on minimum R-25 unfaced fiberglass filled cavity insulation.
 2. Fabric liner facing/vapor barrier composed of woven high-density polyethylene coated on both sides with polyethylene. Complies with the following:
 - a. ASTM C1136, Types I through Type VI
 - i. Type I-IV exception for dimensional stability (value is < 2.0%.)
 - b. Perm rating: 0.02 when tested in accordance with ASTM E 96 Procedure A.
 - c. Flame Spread Index < 25 and Smoke Developed Index < 50 when tested in accordance with ASTM E 84.
 - d. Color: White

3. Vapor barrier adhesive. Complies with the following:
 - a. Application temperature 10°F to 110° F
4. Double sided vapor barrier tape. Complies with the following:
 - a. Width 0.75
 - b. Rubber based and free film
5. Patch tape. Complies with the following:
 - a. Adhesive added to one side
 - b. Installation temperature from 10°F to 110°F
 - c. 3" width
6. Metal Banding/Straps. Complies with the following:
 - a. Coated steel
 - b. 1.0" wide
 - c. Structural Steel Grade 50 per ASTM C 653
 - d. Exposed color to match vapor barrier
 - e. Backing – White
7. Thermal spacer blocks. Complies with the following:
 - a. Extruded polystyrene.
 - b. Minimum width 3.0"
 - c. Thickness 1.0"
 - d. Light gage steel fasteners
 - i. Zinc plated cold forged steel
 - ii. Head color to match vapor barrier
 - iii. Contain rubber sealing washer
 - e. Heavy gage steel fasteners
 - i. Zinc plated cold forged steel
 - ii. Head color to match vapor barrier
 - iii. Contain rubber sealing washer
8. All materials used in OptiLiner Insulation System shall be approved by insulation system manufacturer.
9. Basis of Design Product: OptiLiner Insulation System manufactured by Owens Corning Insulation Systems: www.owenscorning.com.
- C. Wall Insulation System:
 1. Glass fiber blanket metal building insulation, R-19 vinyl vapor retarder faced fiberglass, vapor barrier facing to interior.
 - a. Thermal break
 - i. Closed cell polyethylene foam tape for wall applications. Complies with the following:
 - a) 0.375" thick
 - b) 3.0" wide
 - c) Minimum R-value: 1.5
 - ii. Thermal separation:
 - iii. Vapor Retarder Color: White.
- D. Insulation Vapor Retarder Facing at Wall Insulation: Polypropylene/Fiberglass-Polyester blend fabric.
 1. Weight: 36 pounds per 1000 square feet.
 2. Permeance (ASTM E96 Procedure A): 0.02 perm.
 3. Bursting Strength (ASTM D774): 250 psi.
 4. Puncture Resistance (ASTM C1136): 650 Beach Units.
 5. Tensile Strength (ASTM C1136): 195 lb/in width (MD).
150 lb/in width (XD).
 6. Thickness: 0.007 inch.
 7. Accelerated Aging (30 days @ 95% RH, 120 degrees F): No corrosion, no delamination.
 8. Low Temperature Resistance (ASTM D1790, -40 degrees F): Remains flexible, no delamination.
 9. High Temperature Resistance (4 hours @ 240 degrees F): Remains flexible, no delamination.
 10. Water Immersion (24 hours @ 73 degrees F): No delamination.

11. Mold Resistance (ASTM C665/C1338): No growth.
12. Dimensional Stability (ASTM D1204): 0.25%.
13. Fire Testing:
 - a. Flame Spread (ASTM E84/UL 723): Film Side - 0 Fabric Side - 5.
 - b. Smoke Developed (ASTM #84/UL 723): Film Side - 30 Fabric Side - 40.
14. Basis of Design: Gymguard manufactured by Lamtec Corporation.
- E. Joint Seal Gaskets: Manufacturer's standard type.
- F. Fasteners: Manufacturer's standard type, galvanized to comply with requirements of ASTM A153/A153M, finish to match adjacent surfaces when exterior exposed.
- G. Bituminous Paint: Asphaltic type.
- H. Sealant: ASTM C920, elastomeric sealant with movement capability of at least plus/minus 50 percent; 100 percent silicone; for exposed applications, match adjacent colors as closely as possible.
- I. Metal Mesh: Galvanized steel wire, woven.
- J. Trim, Closure Pieces, Caps, Flashings, Gutters, Downspouts, Rain Water Diverter, Fascias, and Infills: Same material, thickness and finish as exterior sheets; brake formed to required profiles.

205 ACCESSORY COMPONENTS

- A. Doors and Frames: Specified in Section 08 1113.

206 DESIGN CRITERIA

- A. Minimum Thermal Standards: In accord with ICC (IECC) requirements.
 1. Roof: Maximum U-value 0.035.
 2. Wall: Maximum U-value 0.071
- B. Maximum Air Leakage: Provide properly sealed air barrier membrane in accord with C402.5 of ICC (IECC).
- C. Design members to withstand dead load, applicable snow load, and design loads due to pressure and suction of wind calculated in accordance with applicable code.
- D. Design members to withstand loads imposed by suspended gymnasium equipment, scoreboards, divider curtains and other applied loads.
- E. Design members to withstand Uplift Per IBC 2018.
- F. Exterior wall system shall withstand imposed loads with maximum allowable deflection of L/240 of span.
- G. Exterior Roof system shall withstand imposed loads with maximum allowable deflection of L/180 of span.
- H. Provide Hat Channel behind Reverse Roll Paneling
 1. Provide Hat Channel to meet Building Supplier Required Deflection and gauge thickness.
 2. Provide Hat Channel with 7/8" Maximum depth.
- I. Design and provide all necessary framing for equipment platform, including but not limited to the columns, girts, joist, metal deck, angle, channels, accessories, trim, etc. Metal building Designer to coordinate metal building design to support all necessary loads for the equipment platform and concrete pad.
 - a. Equipment Platform Live Load min. 180 PSF; See drawings & Equipment for dead load.
 - b. Equipment Platform Collateral Load of 6 PSF
- J. GC to install Poured reinforced concrete slab on metal building deck. Metal Building designer to coordinate with GC for all necessary bracing, framing and terminate framing.
- K. Metal Building Designer to provide all necessary terminations and connection at the point where the GC installed Metal Pan Stair is to secure back to the metal building structure. Metal pan stair to be designed by GC to be self supported, but must attach to metal building slab and equipment platform framing to create a seamless stair egress assembly for the occupants. GC and Metal Building Designer to coordinate all necessary elements to create a working stair condition.
- L. Provide support framing for support of canopies and canopy tie-backs
- M. Provide drainage to exterior for water entering or condensation occurring within wall or roof system.
- N. Permit movement of components without buckling, failure of joint seals, undue stress on fasteners or other detrimental effects, when subject to temperature range of not less than 100 degrees F.
- O. Size and fabricate wall and roof systems free of distortion or defects detrimental to appearance or performance.

207 FABRICATION - FRAMING

- A. Fabricate members in accordance with AISC 360 for plate, bar, tube, or rolled structural shapes.
- B. Anchor Bolts: Formed with bent shank, assembled with template for casting into concrete.
- C. Provide wall opening framing for doors, windows, and other accessory components.
- D. Design and provide all necessary framing for equipment platform, including but not limited to the columns, girts, joist, metal deck, angle, channels, accessories, trim, etc. Metal building Designer to coordinate metal building design to support all necessary loads for the equipment platform and concrete pad.
- E. Design requirements per the design documents, with GC and design documents for poured concrete pad to be installed on equipment platform.

208 FABRICATION - WALL AND ROOF PANELS

- A. Pre-Finished Exposed Vertical Siding Panels: Aluminum-zinc alloy coated steel, minimum 0.028 inch metal thickness, Vertical PBR Panel profile indicated, 1-1/4 inch deep, lapped edges.
 - 1. Provide stand-off semi-concealed fasteners to minimize insulation compression.
 - 2. Basis of Design: PBR Wall Panel, manufactured by Mesco Building Solutions
- B. Pre-Finished Exposed Vertical Reverse Roll Siding Panels: Aluminum-zinc alloy coated steel, minimum 0.028 inch metal thickness, Vertical Reverse Roll PBR Panel profile indicated, 1-1/4 inch deep, lapped edges.
 - 1. Provide stand-off semi-concealed fasteners to minimize insulation compression.
 - 2. Basis of Design: Reverse Roll PBR Panel, manufactured by Mesco Building Solutions
- C. Pre-Finished Exposed Horizontal Siding Panels: Aluminum-zinc alloy coated steel, minimum 0.028 inch metal thickness, Horizontal PBU Panel profile indicated, 3/4 inch deep, lapped edges.
 - 1. Provide stand-off semi-concealed fasteners to minimize insulation compression.
 - a. Provide Hat Channel behind Reverse Roll Paneling to meet Building Supplier Required Deflection and gauge thickness with a 7/8" Maximum depth.
 - 2. Basis of Design: PBU Wall Panel, manufactured by Mesco Building Solutions
- D. Pre-Finished Metal Roofing Panels: Aluminum-zinc alloy, minimum 0.0299 inch metal thickness, Superlok, SSR profile, 2 inch deep, lapped and machine crimped edges fitted with continuous gaskets.
 - 1. Width: 16 inches.
 - 2. Provide 2 inch sliding clip - High to provide minimum 1-1/2 inch clear space between bottom of roof panel and perlin and thermal block as applicable to minimize insulation compression.
 - 3. Basis of Design: Superlok, SSR Roof Panel, manufactured by Mesco Building Solutions
- E. Pre-Finished Ceiling Liner: NOT USED
- F. Pre-Finished Wall Liner:
 - 1. Basis of Design: ILM-240-2 with Beads Liner Panel, manufactured by Mesco Building Solutions
 - 2. Minimum 0.019 inch metal thickness.
- G. Girts/Purlins: Rolled formed structural shape to receive siding, roofing and liner sheet.
 - 1. Girts/Purlins designed to meet design criteria deflection
 - 2. Stiffened Girts to be used at North and South Walls where Double Girt conditions occur where façade bumps occurs. See design drawings.
- H. Internal and External Corners: Same material thickness and finish as adjacent material, profile brake formed to required angles. Back brace mitered internal corners with same material thickness and finish as adjacent material.
- I. Expansion Joints: Same material and finish as adjacent material where exposed, 0.028 inch thick, manufacturer's standard brake formed type, of profile to suit system.
- J. Flashings, Closure Pieces, Fascia: Same material and finish as adjacent material, profile to suit system.
- K. Fasteners: To maintain load requirements and weather tight installation, same finish as cladding, non-corrosive type.

209 FABRICATION - GUTTERS AND DOWNSPOUTS

- A. Fabricate of same material and finish as roofing metal.
- B. Form gutters and downspouts and scuppers of rectangular profile and size to collect and remove water. Fabricate with connection pieces.
- C. Form sections in maximum possible lengths. Hem exposed edges. Allow for expansion at joints.
- D. Fabricate support straps of same material and finish as roofing metal, color as selected.

210 FINISHES

- A. Framing Members: Clean, prepare, and shop prime. Do not prime surfaces to be field welded.
- B. Exterior Surfaces of Wall Components and Accessories: Precoated enamel on steel of manufacturer's standard PVDF finish, coating color as selected from manufacturer's standard range.
- C. Interior Surfaces of Wall Components and Accessories: Precoated enamel on steel of manufacturer's standard polyester finish, coating color as selected from manufacturer's standard range.

PART 3 EXECUTION

3.01 EXAMINATION

- A. Verify that foundation, floor slab, mechanical and electrical utilities, and placed anchors are in correct position

3.02 ERECTION - FRAMING

- A. Erect framing in accordance with AISC 360.
- B. Provide for erection and wind loads. Provide temporary bracing to maintain structure plumb and in alignment until completion of erection and installation of permanent bracing. Locate braced bays as indicated.
- C. Set column base plates with non-shrink grout to achieve full plate bearing.
- D. Do not field cut or alter structural members without approval.
- E. After erection, prime welds, abrasions, and surfaces not shop primed.

3.03 ERECTION - WALL AND ROOF PANELS

Install in accordance with manufacturer's instructions.

Exercise care when cutting prefinished material to ensure cuttings do not remain on finish surface.

Fasten cladding system to structural supports, aligned level and plumb.

Panel End Laps: Minimum of 6 IN, sealed with sealant (weather sealing compound), and fastened together by clamping plates.

Sealants: Contain hard nylon beads, which prevent mastic from flowing out due to clamping actions. Join panel laps by 2-piece clamped connection consisting of a bottom reinforcing plate and a top panel strap.

Locate panel end laps directly over, but not fastened to, supporting secondary roof structural member and stagger, to avoid 4-panel lap-splice condition.

Metal Wall System Installation:

Install wall system in accordance with metal building system manufacturer's instructions at locations indicated on the Drawings.

Install wall system weathertight.

Verify structural system is plumb before wall panels are attached.

Apply foam single-sided thermal separation tape to outside face of girts.

Seal wall panels with molded-foam closure block that fits panel configuration at top and bottom of wall panels.

Exterior Trim: Match exterior color and embossing of wall panel system.

Interior Trim: Painted.

Flashings, Trim, Closures, and Similar Items: Install as indicated on erection drawings furnished by metal building system manufacturer.

Provide expansion joints where indicated.

Install insulation and vapor retarder utilizing manufacturer's standard detail for attachment.

Place wire mesh under vapor retarder for support between framing members.

Install sealant and gaskets, providing weather tight installation.

3.04 INSTALLATION - INSULATION

- A. Instructions and approved Shop Drawings.

1. Refer to the Owens Corning publications listed below for product information, including uses, descriptions, physical properties, performance, specification compliance and application recommendations. Copies of these documents can be found at www.owenscorning.com.
 - a. OptiLiner® Banded Liner System Product Data Sheet - Owens Corning Publication 10011681
 - b. OptiLiner® Wall Installation Instructions - Owens Corning Publication 10011266
 - c. OptiLiner® Roof Installation Instructions - Owens Corning Publication 10011267
 - d. OptiLiner® Bi-Directional Banding Option - Owens Corning Publication 10011602
- B. Purlin and girt attachment surfaces should be clean and dry prior to attaching two-faced tape or sealing adhesive.
- C. Installed fiberglass insulation should fit snugly against purlin and girt walls in the cavity space. Avoid gaps, voids and any excess compression.

3.05 ERECTION - GUTTERS AND DOWNSPOUTS

- A. Rigidly support and secure components. Join lengths with formed seams sealed watertight. Flash and seal gutters to downspouts.
- B. Slope gutters minimum 1/8 inch/ft.
- C. Connect downspouts to storm sewer system.

3.06 INSTALLATION - ACCESSORY COMPONENTS IN WALL SYSTEM

- A. Install door frames, doors, overhead doors, and windows and glass in accordance with manufacturer's instructions.
- B. Install liner panels where indicated on Drawings. Provide wall liner panels both at perimeter (exterior) walls and at interior partitions, including light gage metal furring where required.

3.07 TOLERANCES

- A. Framing Members: 1/4 inch from level; 1/8 inch from plumb.
- B. Siding and Roofing: 1/8 inch from true position.

3.08 FIELD QUALITY CONTROL

All inspections and tests are to be performed at the Project site by a third party independent testing agency.

Inspect field welding in accordance with AWS D1.1/D1.1M, Section 6 including the following non-destructive testing:

Visually inspect all welds.

Test 50 PCT of full penetration welds and 10 PCT of fillet welds with liquid dye penetrant.

Test 20 PCT of full penetration welds with ultrasonic or radiographic testing.

Inspect high-strength bolting in accordance with the RCSC Specification for Structural Joints, Section 9.

Inspect while work is in progress.

Inspect structural steel which has been erected.

Prepare and submit test reports to Engineer.

END OF SECTION

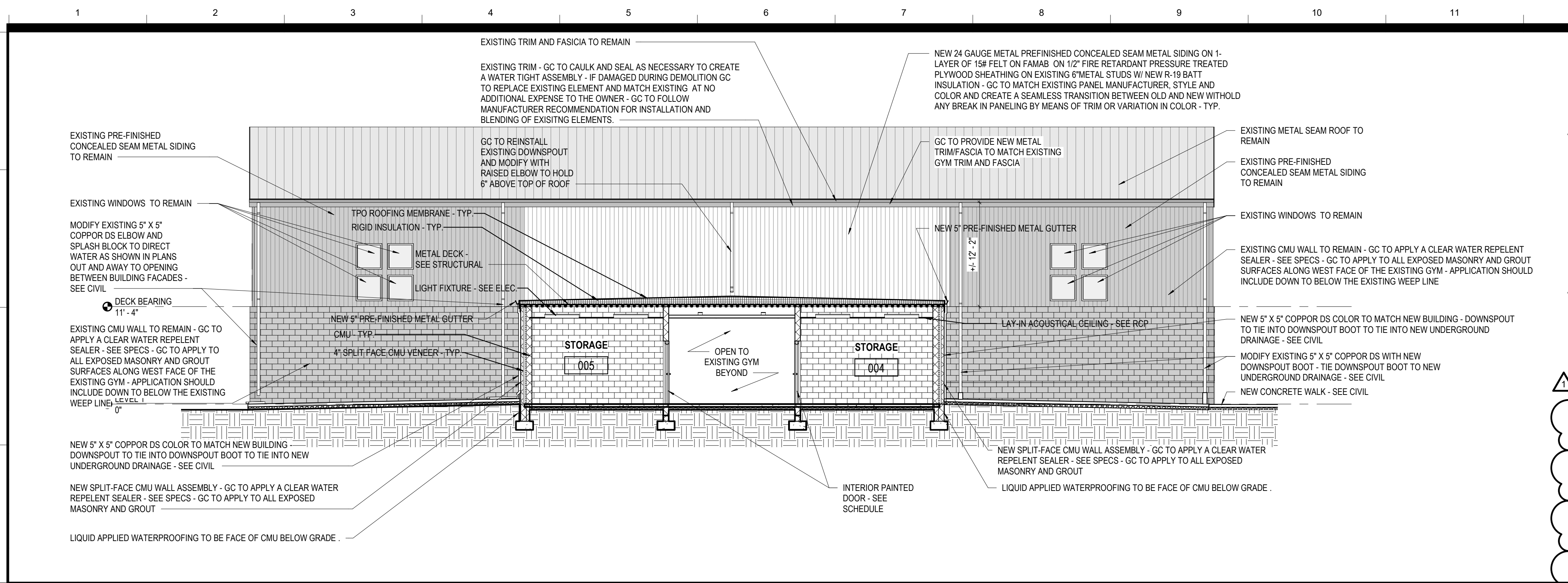

LEGEND - EXTERIOR MATERIALS AND FABRICATIONS			
MARK	PRODUCT	COLOR	COMMENTS
◇	VERTICAL PBR PANEL (1 1/4")	MESCO - ALMOND (300 STANDARD)	SEE GENERAL NOTE 1, 2, 4 & 6
◇	VERTICAL REVERSE ROLL PBR PANEL (1 1/4")	MESCO - MIDNIGHT BRONZE (300 STANDARD)	SEE GENERAL NOTE 1, 2, 4, 5 & 6
◇	HORIZONTAL PBU PANEL (3/4")	MESCO - PACIFIC BLUE (300 STANDARD)	SEE GENERAL NOTE 1, 2, 4 & 6
◇	SSR SUPER LOK (2")	MESCO - SNOW WHITE (300 STANDARD)	SEE GENERAL NOTE 7
◇	SPLIT FACE 4" VENEER CMU (COLOR 1)	TBD SELECTION BY ARCHITECT	SEE GENERAL NOTE 3, 8, 10 & 11
◇	SPLIT FACE 4" VENEER CMU (COLOR 2)	TBD SELECTION BY ARCHITECT	SEE GENERAL NOTE 3, 8, 10 & 11
◇	SPLIT FACE 4" VENEER CMU (COLOR 3)	TBD SELECTION BY ARCHITECT	SEE GENERAL NOTE 3, 8, 10 & 11
◇	PRE-FINISHED METAL CANOPY W/ LIGHT BELOW	CUSTOM COLOR SELECTED BY ARCHITECT	SEE GENERAL NOTE 9
◇	PRE-FINISH ALUMINUM BAHAMA STYLE SHUTTER	LARSON SHUTTER COMPANY - HAMILTON BLUE	SEE GENERAL NOTE 9 & 12
◇	PRE-FINISHED METAL CAPS	MESCO - ALMOND	
◇	ROOF RIDGE	MESCO - WHITE SNOW	
◇	GUTTERS, DOWNSPOUTS, TYPICAL & RAKE TRIM	MESCO - ALMOND	

- GENERAL NOTES
- ALL FRAMED OPENINGS TRIM COLOR TO MATCH SURROUNDING METAL PANEL COLOR.
 - ALL PENETRATIONS THROUGH PEMB BUILDING BY OTHERS TO BE COORDINATED WITH THE PEMB MANUFACTURER RECOMMENDATION FOR FLASHING AND SEALING THE CONDITIONS PRIOR TO INSTALLATION. GC TO PROVIDE FLASHING AND SEAL ALL PENETRATIONS AS RECOMMENDED TO MAINTAIN A LONG LASTING WATER TIGHT FACADE AND PROPER DRAINAGE.
 - ALL EXPOSED LOCATIONS OF NEW MASONRY ASSEMBLIES TO BE TREATED WITH CLEAR WATER REPELLENT AS LISTED PER THE UNIT MASONRY SPECIFICATION.
 - ALL METAL WALL PANEL ASSEMBLIES SHOULD BE DESIGN TO MEET A MINIMUM OF L/240 DEFLECTION.
 - PEMB TO DESIGN METAL WALL PANEL ASSEMBLY WITH 7/8" GALVANIZED HAT CHANNEL FURRING BEHIND METAL PANEL ATTACHED TO FACE OF GIRT.
 - PEMB METAL PANEL TO HAVE SEMI-CONCEALED FASTENERS.
 - PEMB METAL PANEL TO BE FULLY CONCEALED AND MECHANICALLY SEALED.
 - 8" SPLIT FACE CMU @ EXTERIOR MECHANICAL ENCLOSURE IN LIEU OF 4" SPLIT FACE CMU VENEER.
 - PEMB MANUFACTURER TO PROVIDE ADDITIONAL GIRT REINFORCEMENT AND BRACING AS NEEDED (SHOWN AS DASHED WITH DIAGONAL HATCH FOR SIGNAGE - GC TO COORDINATE SIGNAGE LOCATION, STRUCTURAL REQUIREMENTS AND ATTACHMENT INFORMATION WITH THE PEMB MANUFACTURER PRIOR TO APPROVAL OF SHOP DRAWINGS.
 - PEMB METAL PANELS ARE TO EXTEND BEHIND ALL MASONRY AND BE TAKEN TO TOP OF CONCRETE SLAB CURB AND BE SEALED.
 - PEMB METAL PANELS BEHIND MASONRY ARE TO BE REVERSE ROLL PANELS INSTALLED FOR MASONRY TIE DIRECT ATTACHMENT.
 - SHUTTER TO INCLUDE: A CENTER MULLION, TWO (2) ADJUSTABLE ALUMINUM SUPPORTS AND A SELF DRAINING ALUMINUM HINGE.

K1 EXISTING GYM - WEST EXTERIOR WALL REWORK ELEVATION
 SCALE: 1/8" = 1'-0"

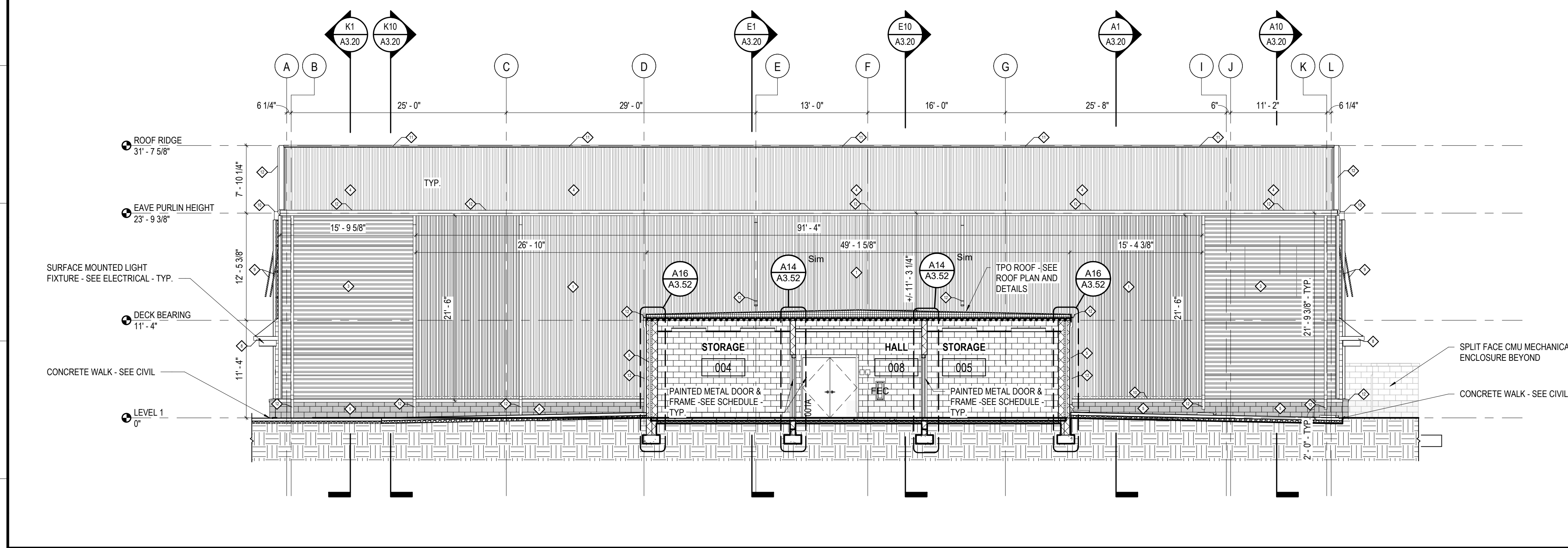

F1 EXTERIOR BUILDING ELEVATION - EAST
 SCALE: 1/8" = 1'-0"

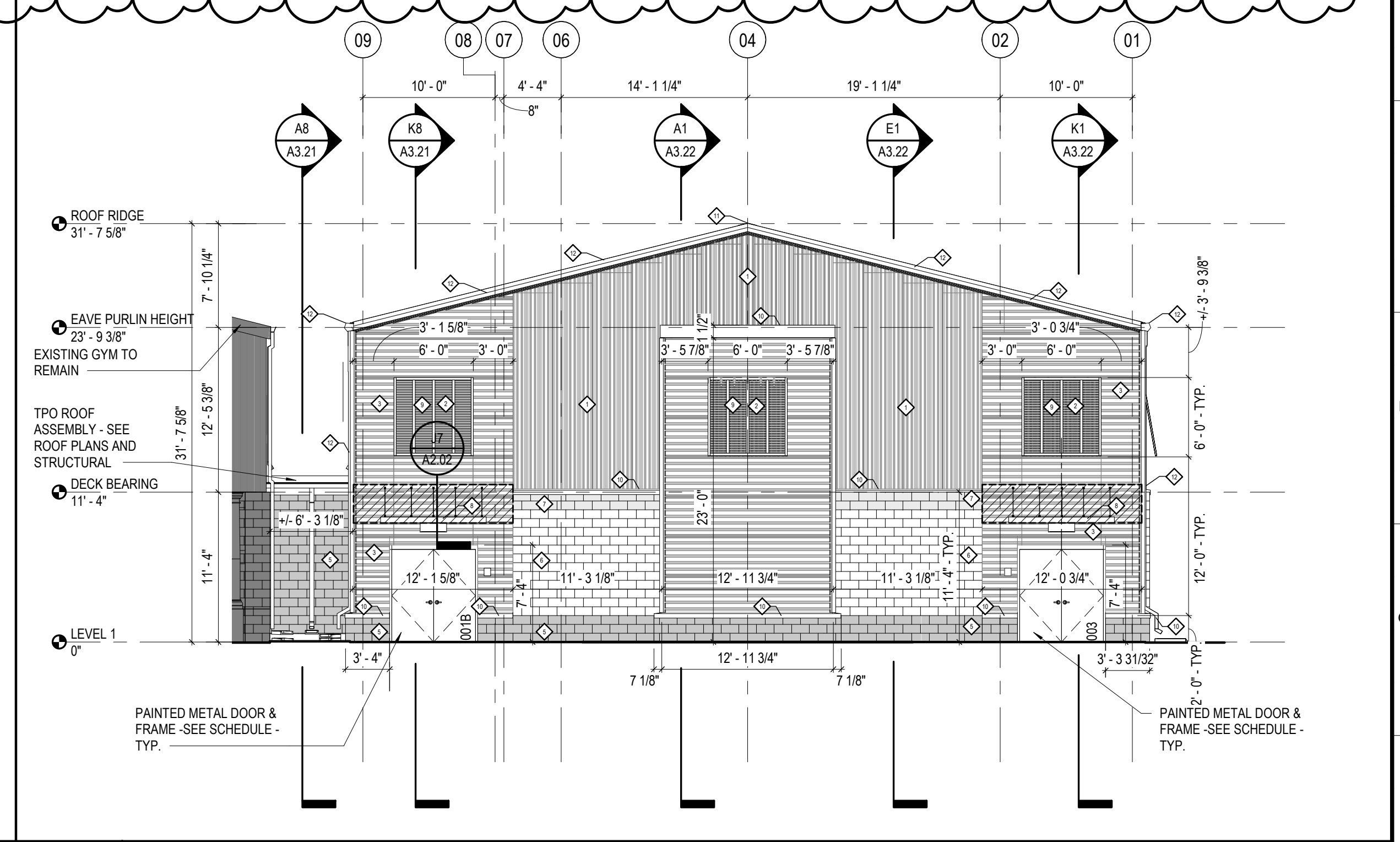

F12 EXTERIOR BUILDING ELEVATION - NORTH
 SCALE: 1/8" = 1'-0"

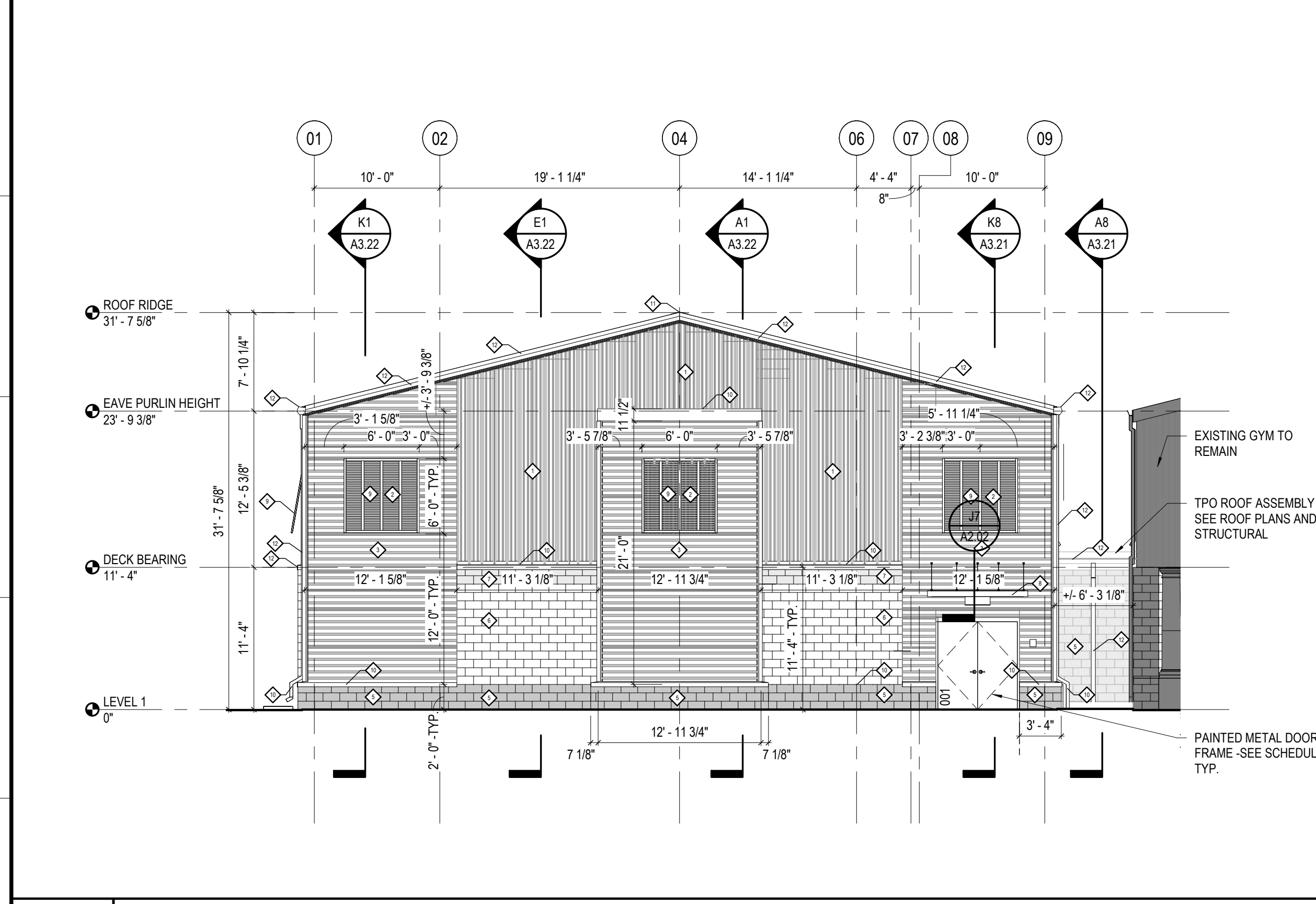

A1 EXTERIOR BUILDING ELEVATION - SOUTH
 SCALE: 1/8" = 1'-0"

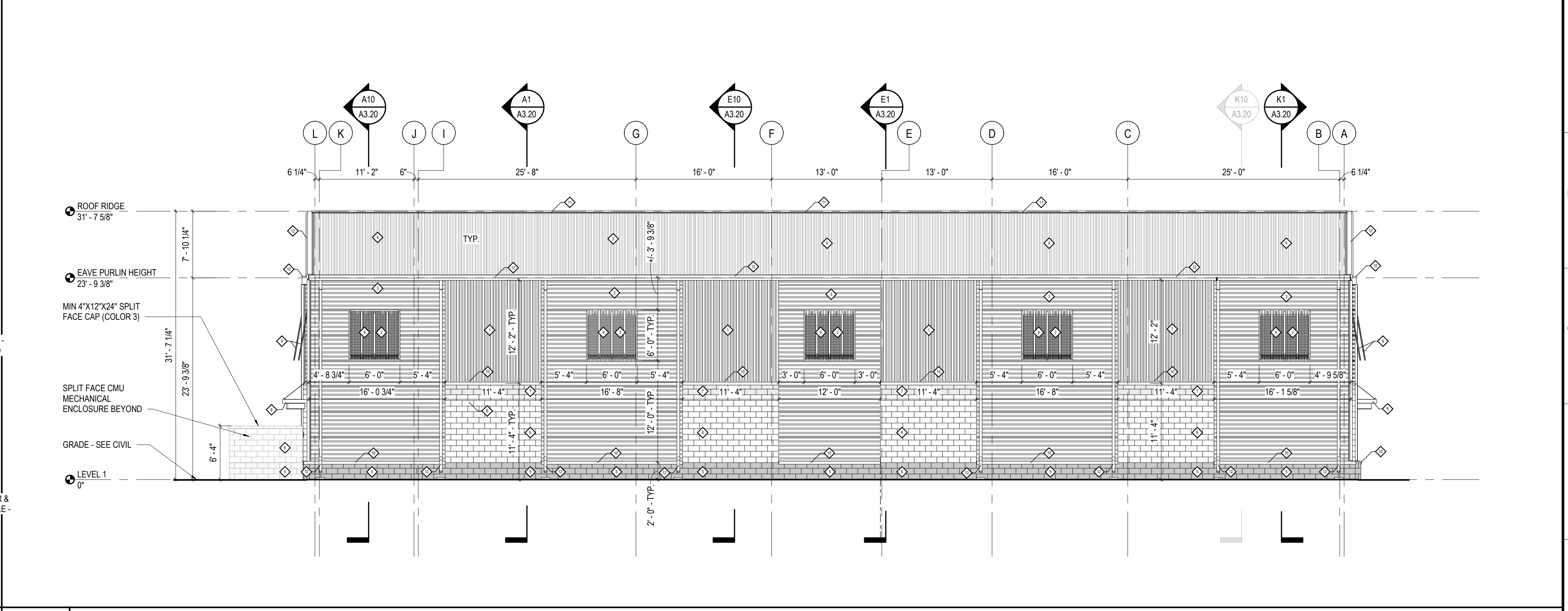

A7 EXTERIOR BUILDING ELEVATION - WEST
 SCALE: 1/8" = 1'-0"

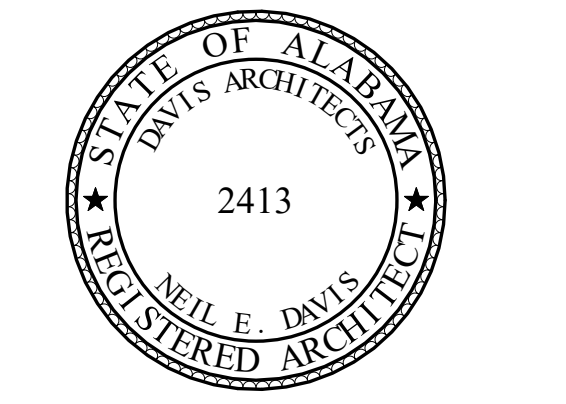

**ORANGE BEACH
 RECREATION COMPLEX
 NEW GYMNASIUM**



CITY OF ORANGE BEACH;
 ORANGE BEACH, AL

DAVIS ARCHITECTS

OWNER
 CITY OF ORANGE BEACH
 PO BOX 458
 ORANGE BEACH, ALABAMA 36561
 251-981-6979
 ATTN: KEN GRIMES, JR.

ASSOCIATE ARCHITECT
 MCCOLLUGH ARCHITECTURE
 4760 MAIN ST #209
 ORANGE BEACH, AL 36561
 ATTN: STEVE MCCOLLUGH

ARCHITECT
 DAVIS ARCHITECTS, INC.
 120 23RD STREET SOUTH
 BIRMINGHAM, AL 35233
 205-322-7482
 ATTN: JIM HARTSELL / JEFFREY MENASCO

CIVIL ENGINEER
 SAWGRASS CONSULTING, LLC
 11143 OLD HIGHWAY 31
 SPANISH FORT, AL 36527
 251-544-7900
 ATTN: ERIC E. GODWIN / DOUG CHAFFIN

STRUCTURAL ENGINEER
 M&A ENGINEERS
 300 20TH ST. N., SUITE 100
 BIRMINGHAM, AL 35203
 205-323-6386
 ATTN: KEITH OWENS / MARK BOGER

MECHANICAL / PLUMBING ENGINEER
 GULF STATES ENGINEERING
 600 AZALEA ROAD,
 MOBILE, AL 36609
 251-460-4648
 ATTN: CHRIS DEARMON / VAN SIMPSON

FIRE PROTECTION ENGINEER
 GULF STATES ENGINEERING
 600 AZALEA ROAD,
 MOBILE, AL 36609
 251-460-4648
 ATTN: TOM WADE / BRIAN DOVE

ELECTRICAL ENGINEER
 GULF STATES ENGINEERING
 600 AZALEA ROAD,
 MOBILE, AL 36609
 251-460-4648
 ATTN: JERRY ONWU / SID SNYDER

REV	DATE	DESCRIPTION
1	3/13/2019	ADDENDUM #1

DATE: 2-18-2019
 PHASE: 100% CONSTRUCTION DOCUMENTS
 SHEET NO: ADDENDUM #1
 DRAWN BY: DAVIS ARCHITECTS PROJECT NO: 3891.01
 SHEET TITLE: EXTERIOR ELEVATIONS

DRAWING NO. **A3.01**

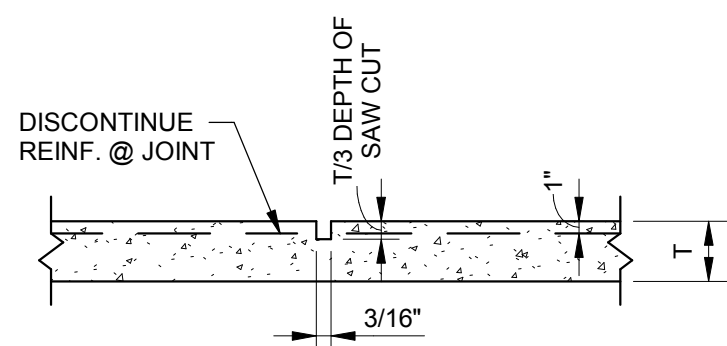

TYPICAL SAWED CONTROL JOINT

- NOTES:
 1. USE SAWS, BLADES AND SKID PLATES BY SOFF-CUT INTERNATIONAL OR EQUAL.
 2. SEE PLAN FOR JOINT LAYOUT.
 3. START CUTTING SAWED JOINTS AS SOON AS CONCRETE HAS HARDENED SUFFICIENTLY TO PREVENT RAVELING OR DISLODGING OF AGGREGATES. THIS WILL TYPICALLY BE FROM 1 HOUR IN HOT WEATHER TO 4 HOURS IN COLD WEATHER AFTER COMPLETING FINISHING OF SLAB IN THAT JOINT LOCATION.
 4. EXTEND SAWED JOINT TO THE SLAB BOUNDARIES AND ABUTMENTS, INCLUDING COLUMNS, DRAINS AND OTHER PENETRATIONS IN THE PATH OF A DEFINED JOINT. IMPLEMENT METHODS AND TIMING OF THE SAW CUT BEYOND THE LIMITS OF THE SOFF-CUT SAW REACH TO PROVIDE A CONSISTENT DEPTH OF CUT WITH MINIMAL RAVELING OF JOINT EDGES.
 5. T = SLAB THICKNESS (SEE PLAN)

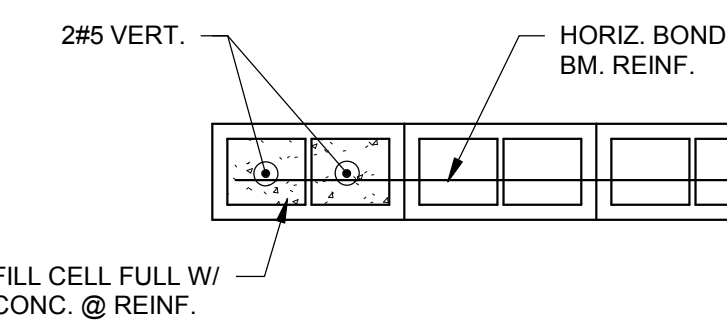

TYPICAL JAMB AND END OF MASONRY WALL REINF. DETAIL

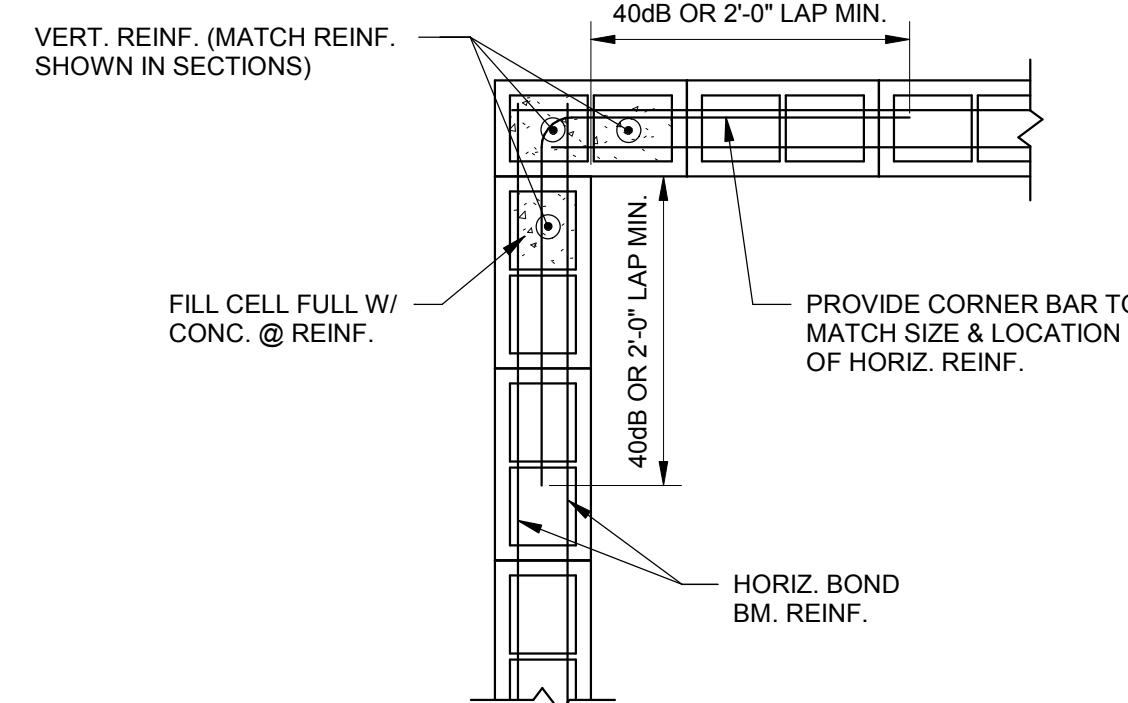

TYPICAL CORNER MASONRY WALL REINF. DETAIL

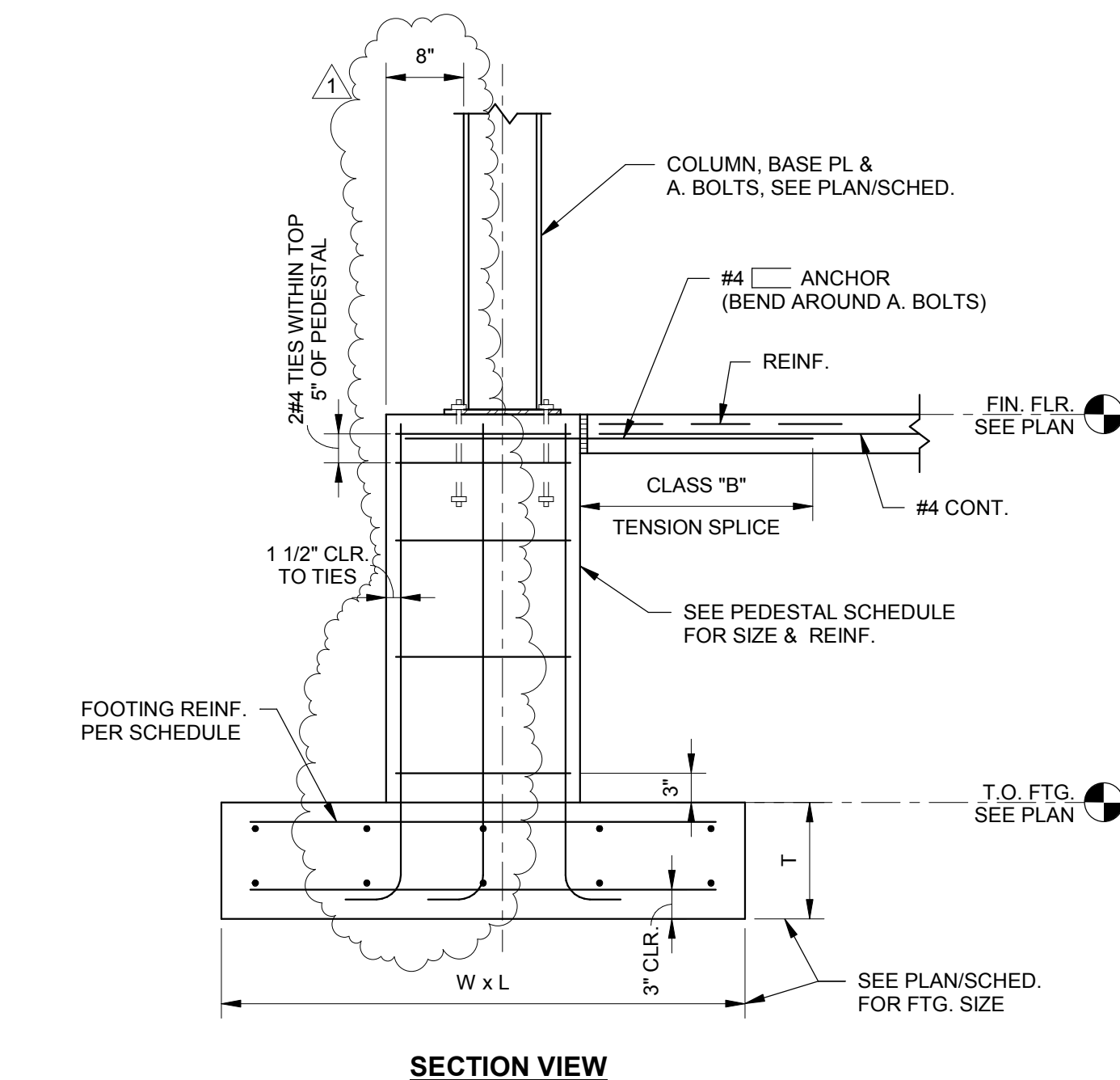
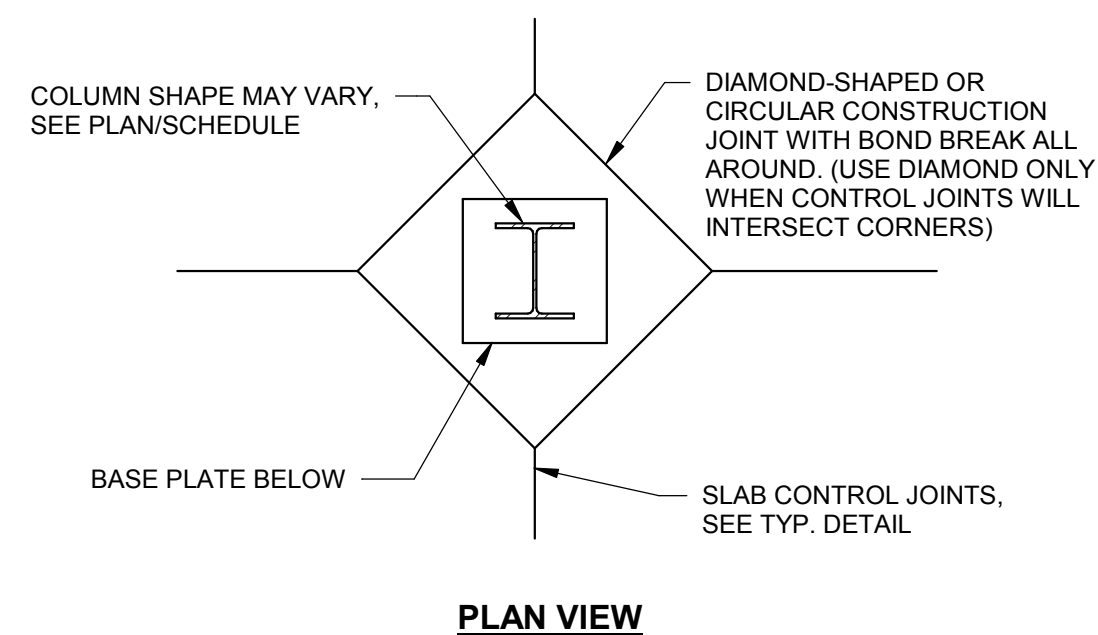

TYPICAL COLUMN FOOTING DETAILS

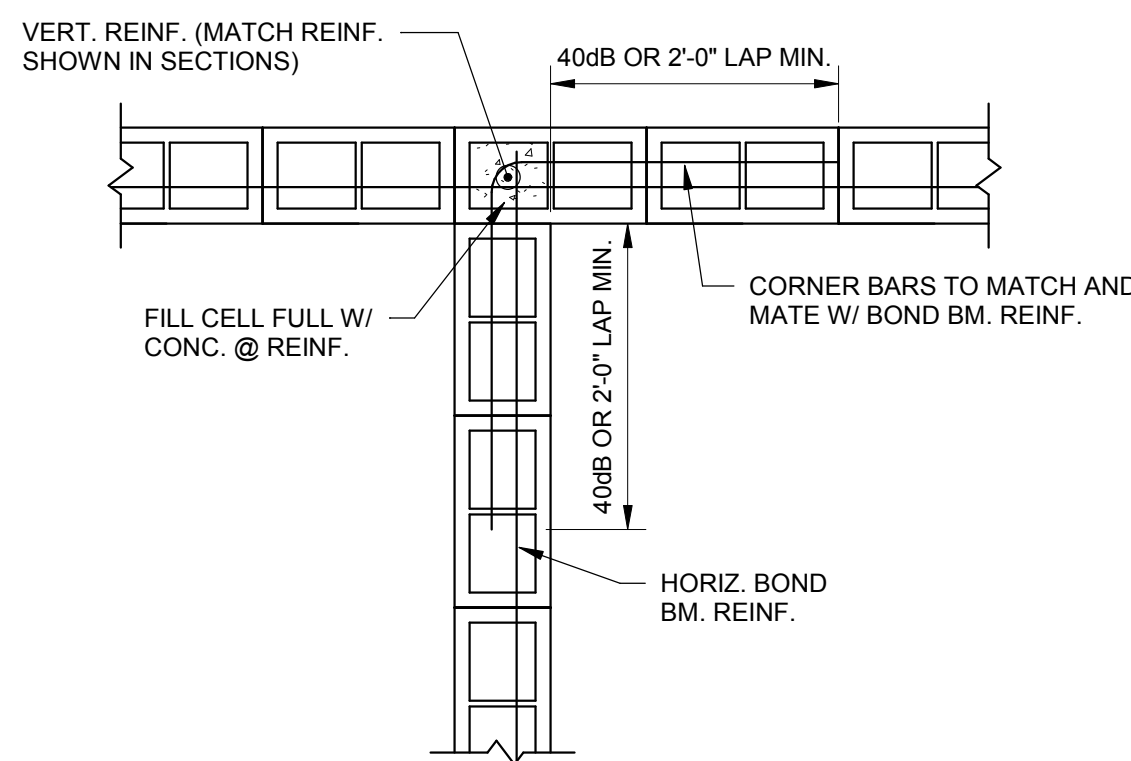

TYPICAL INTERSECTION MASONRY WALL REINF. DETAIL

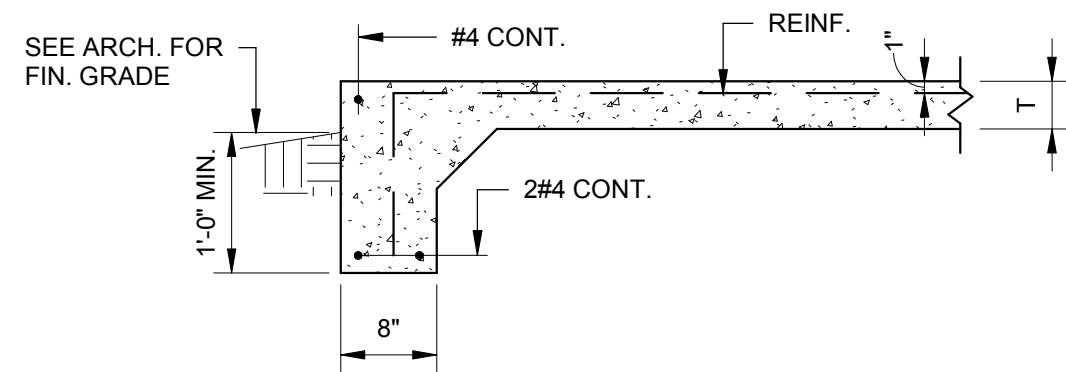

TYPICAL TURNDOWN SLAB DETAIL

NOTE:
 T = SLAB THICKNESS (SEE PLAN)

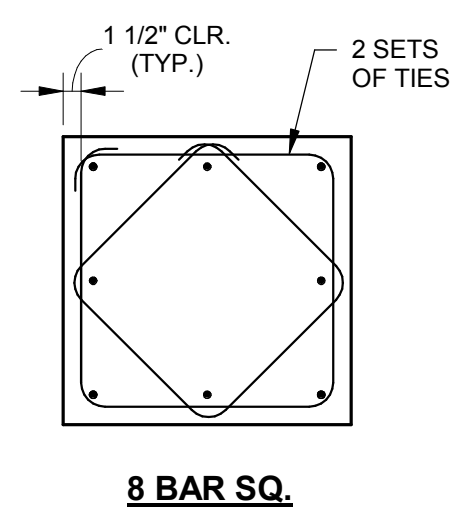

TYPICAL PEDESTAL TIE ARRANGEMENTS

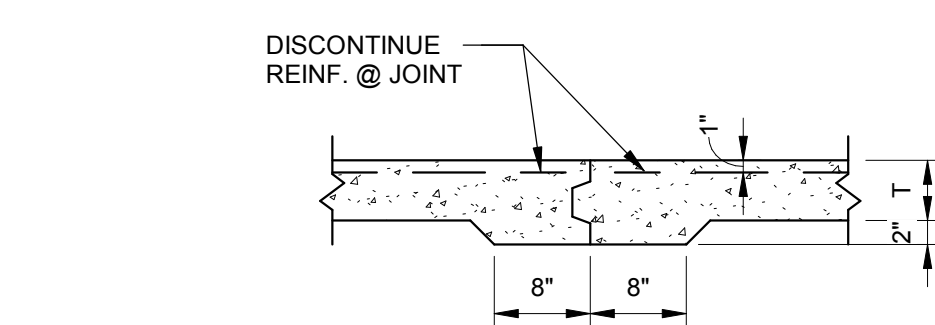

TYPICAL KEYED CONTROL JOINT

- NOTES:
 1. T=SLAB THICKNESS (SEE PLAN)
 2. SEE PLAN FOR LOCATION OF JOINTS

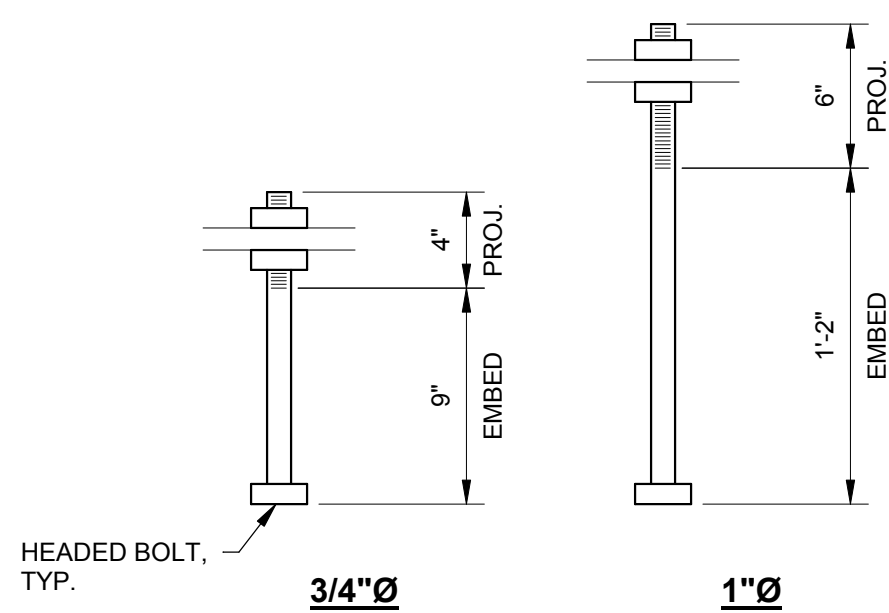

TYPICAL ANCHOR BOLT DETAILS

USE ASTM F1554 GRADE 55 WITH WELDABILITY SUPPLEMENT S1 FOR ALL ANCHOR BOLTS UNO.

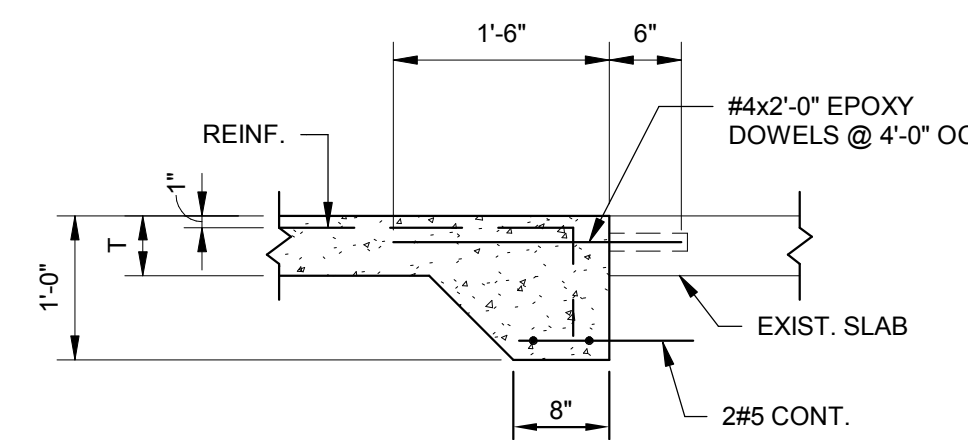

TYPICAL NEW SLAB ON GRADE TO EXIST. SLAB CONNECTION DETAIL

NOTE:
 T = SLAB THICKNESS (SEE PLAN)

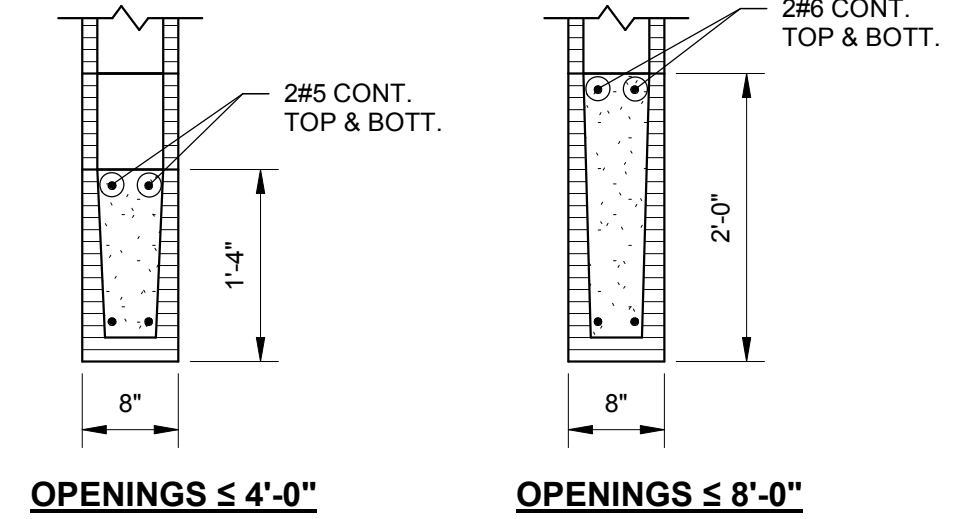

TYPICAL CMU WALL LINTEL DETAILS



ORANGE BEACH RECREATION COMPLEX NEW GYMNASIUM



CITY OF ORANGE BEACH;
 ORANGE BEACH, AL



OWNER
 CITY OF ORANGE BEACH
 PO BOX 458
 ORANGE BEACH, ALABAMA 36561
 251-981-6979
 ATTN: KEN GRIMES, JR.

ASSOCIATE ARCHITECT
 MCCOLLOUGH ARCHITECTURE
 4790 MAIN ST #205
 ORANGE BEACH, AL 36561
 251-988-7222
 ATTN: STED MCCOLLOUGH

ARCHITECT
 DAVIS ARCHITECTS, INC.
 120 23RD STREET SOUTH
 BIRMINGHAM, AL 35233
 205-322-7482
 ATTN: JIM HARTSELL / JEFFREY MENASCO

CIVIL ENGINEER
 SAWGRASS CONSULTING, LLC
 11143 OLD HIGHWAY 31
 SPANISH FORT, AL 36527
 251-544-7900
 ATTN: ERIC E. GODWIN / DOUG CHAFFIN

STRUCTURAL ENGINEER
 MBA ENGINEERS
 300 20TH ST. N., SUITE 100
 BIRMINGHAM, AL 35203
 205-323-6386
 ATTN: KEITH OWENS / MARK BOGER

MECHANICAL / PLUMBING ENGINEER
 GULF STATES ENGINEERING
 600 AZALEA ROAD,
 MOBILE, AL 36609
 251-460-4648
 ATTN: CHRIS DEARMON / VAN SIMPSON

FIRE PROTECTION ENGINEER
 GULF STATES ENGINEERING
 600 AZALEA ROAD,
 MOBILE, AL 36609
 251-460-4648
 ATTN: TOM WADE / BRIAN DOVE

ELECTRICAL ENGINEER
 GULF STATES ENGINEERING
 600 AZALEA ROAD,
 MOBILE, AL 36609
 251-460-4648
 ATTN: JERRY ONWU / SID SNYDER

REV	DATE	DESCRIPTION
1	3/3/2019	ADDENDUM #1

DATE	2-18-2019
TITLE	100% CONSTRUCTION DOCUMENTS
ISSUED FOR	Addendum #1
ISSUED BY	DAVIS ARCHITECTS
PROJECT NO.	3981.01

SHEET TITLE
 TYPICAL DETAILS

DRAWING NO.

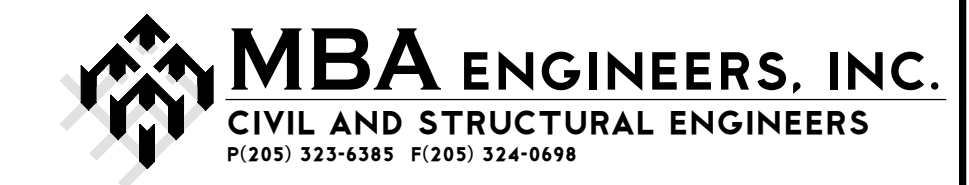

S1.02

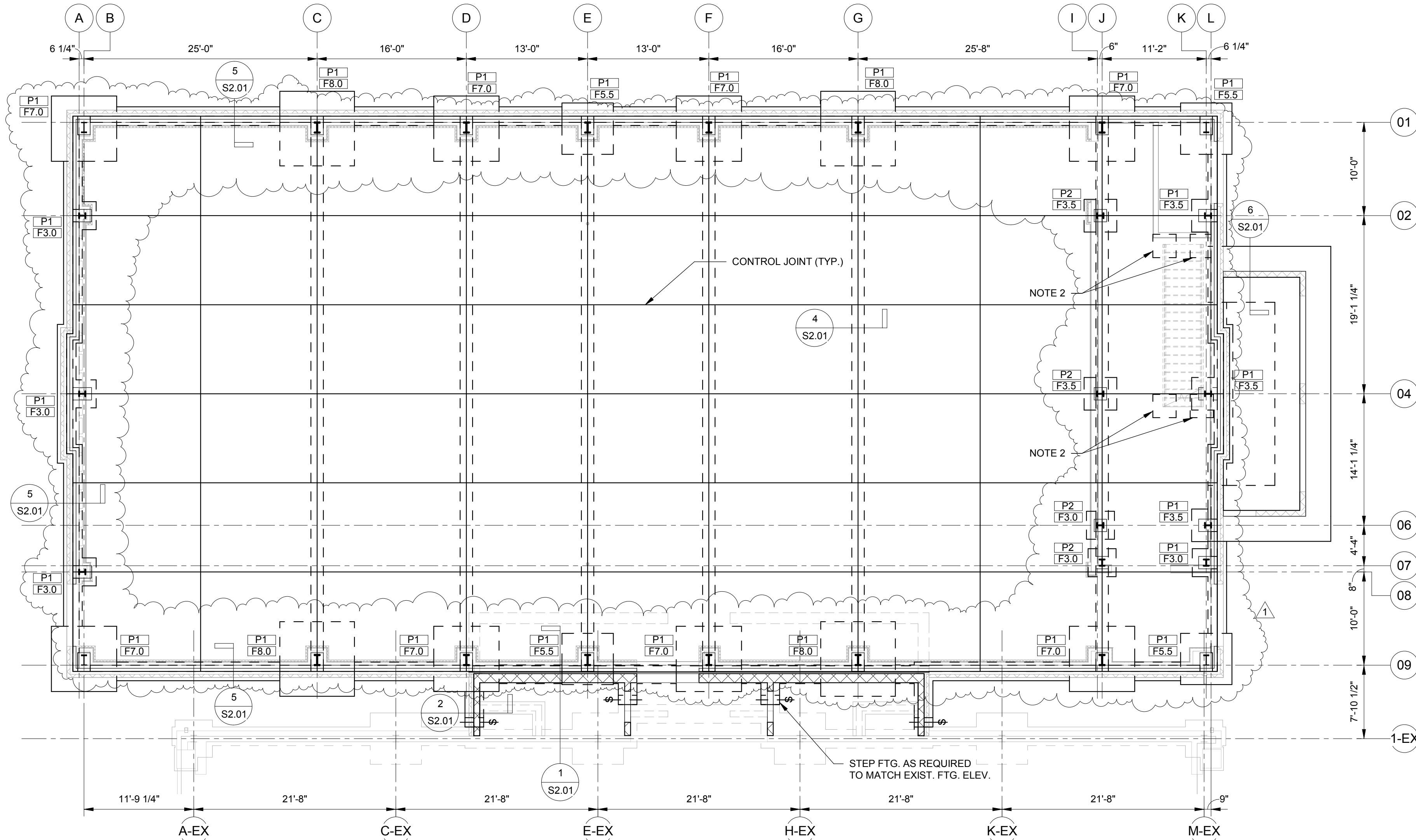

FOOTING SCHEDULE				
MARK	WIDTH	LENGTH	THICKNESS	REINFORCING
F3.0	3'-0"	3'-0"	1'-0"	3#5 EW, TOP & BOTT.
F5.5	3'-6"	3'-0"	1'-0"	4#5 EW, TOP & BOTT.
F7.0	5'-6"	5'-6"	2'-0"	10#5 EW, TOP & BOTT.
F8.0	7'-0"	7'-0"	2'-0"	9#5 EW, TOP & BOTT.
F8.0	8'-0"	8'-0"	2'-0"	10#5 EW, TOP & BOTT.

FOUNDATION AND FLOOR PLAN
 1/8" = 1'-0"
 FIN. FLR. ELEV. 0'-0"
FLOOR CONSTRUCTION:
 4" N.W. CONC. SLAB ON DRAINAGE FILL. REINF. W/ 6x6-W14xW14 WWR.
NOTES:
 1. TOP OF FOOTING ELEV. (-2'-0") BELOW FIN. FLR. UNLESS NOTED THUSLY (-X'-X").
 2. PROVIDE 2'-6" SQ. x 1'-0" DEEP THICKENED SLAB @ STAIR POSTS & STRINGER SUPPORTS.

PEDESTAL SCHEDULE					
MARK	WIDTH	HEIGHT	REINF.	TIES	REMARKS
P1	16"	24"	5#6	2#4 @ 12" OC.	
P2	16"	16"	6#6	2#4 @ 12" OC.	

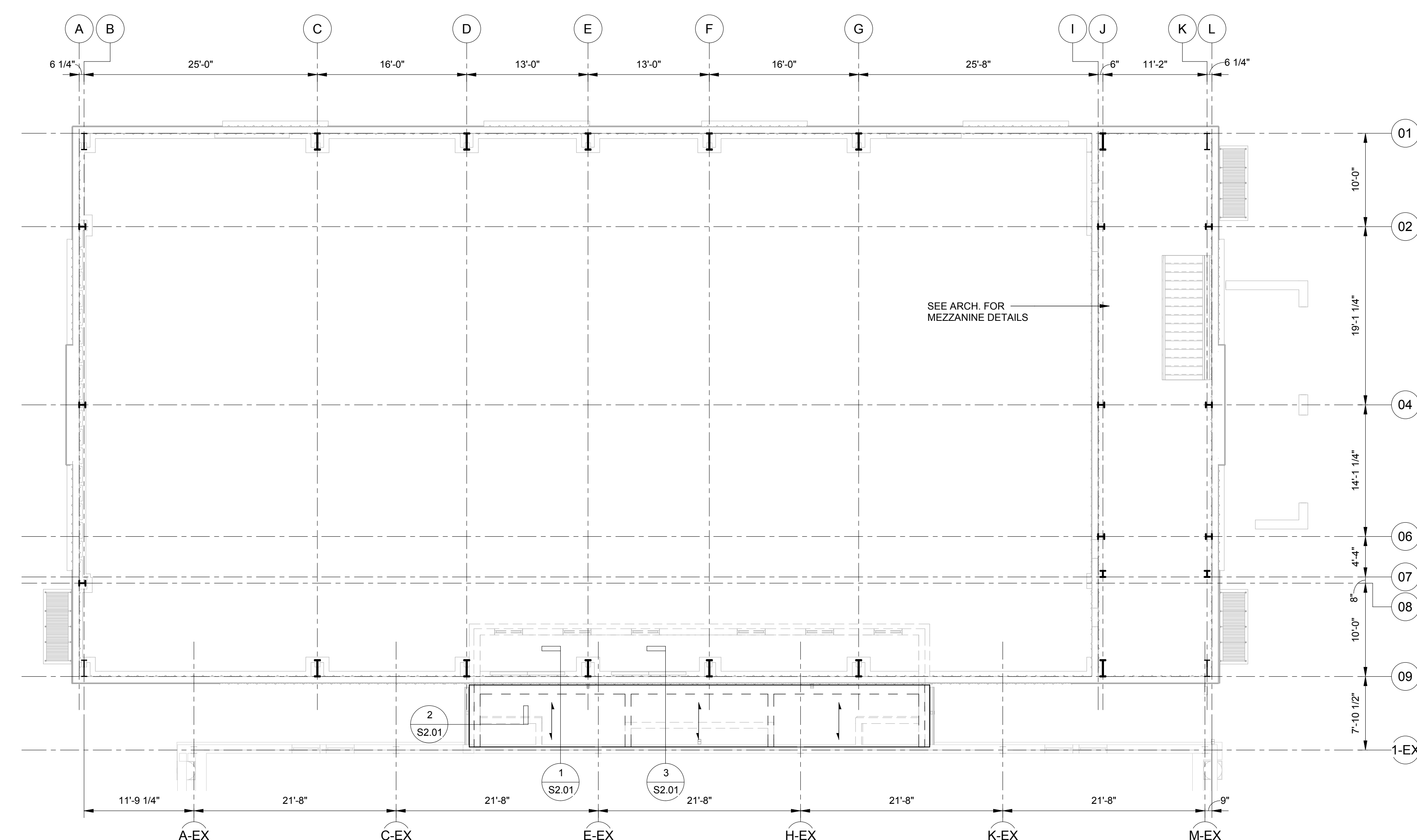

MEZZANINE & LOW ROOF FRAMING PLAN
 1/8" = 1'-0"
LOW ROOF CONSTRUCTION:
 3" DEEP, 22 GA. GALV. (TYPE 3N) METAL ROOF DECK

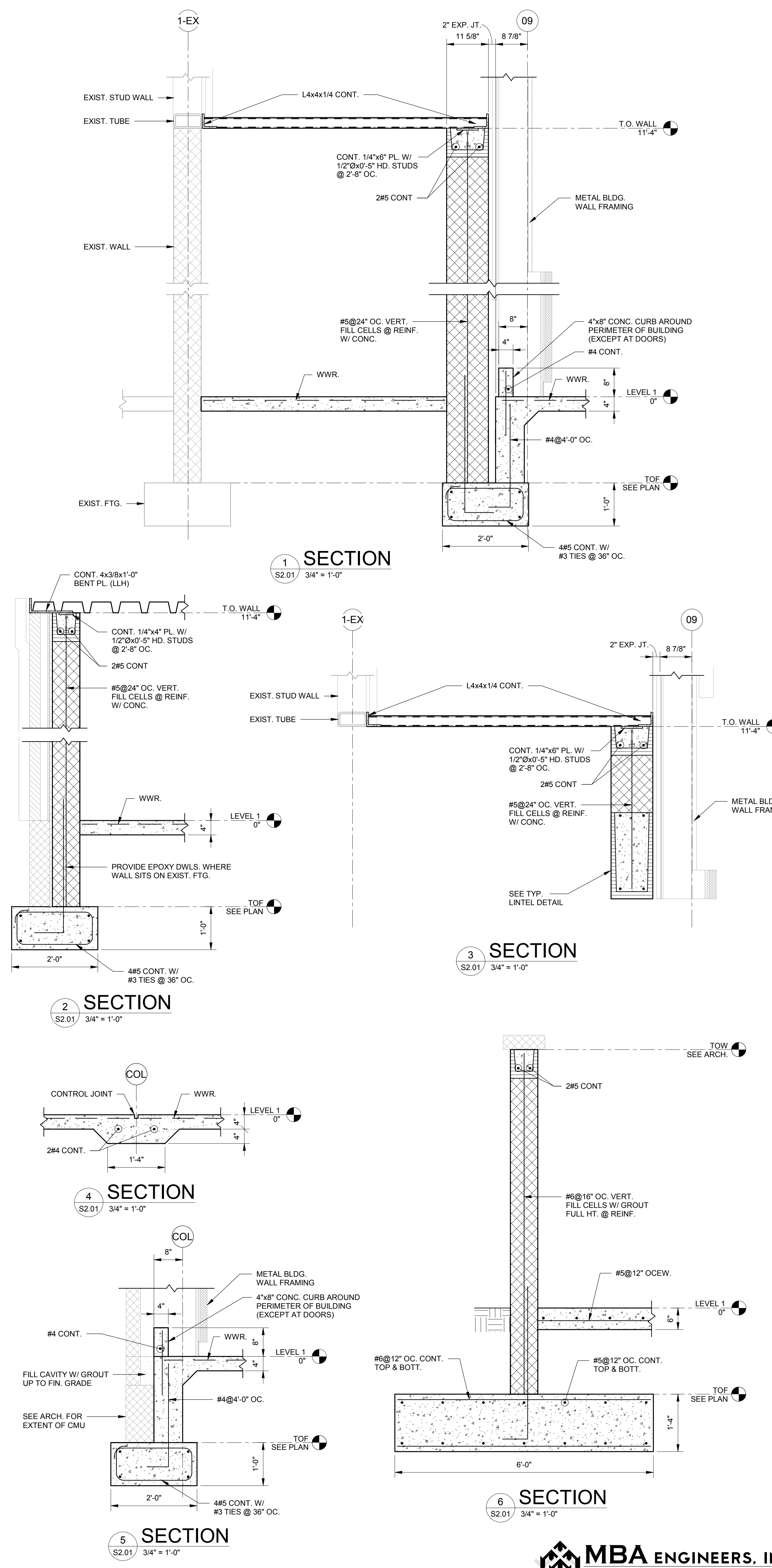

ORANGE BEACH RECREATION COMPLEX NEW GYMNASIUM
 CITY OF ORANGE BEACH, ALABAMA 36561
 ATTN: KEN GRIMES, JR.



OWNER
 CITY OF ORANGE BEACH
 PO BOX 455
 ORANGE BEACH, ALABAMA 36561
 251-981-6979
 ATTN: KEN GRIMES, JR.

ASSOCIATE ARCHITECT
 MCCOLLOUGH ARCHITECTURE
 4750 MAN ST #205
 ORANGE BEACH, AL 36561
 251-988-7222
 ATTN: STED MCCOLLOUGH

ARCHITECT
 DAVIS ARCHITECTS, INC.
 120 23RD STREET SOUTH
 BIRMINGHAM, AL 35233
 205-322-7482
 ATTN: JIM HARTSELL / JEFFREY MENASCO

CIVIL ENGINEER
 SAWGRASS CONSULTING, LLC
 11143 OLD HIGHWAY 31
 SPANISH FORT, AL 36527
 251-544-7900
 ATTN: ERIC L. E. GODWIN / DOUG CHAFFIN

STRUCTURAL ENGINEER
 MBA ENGINEERS
 300 20TH ST. N., SUITE 100
 BIRMINGHAM, AL 35203
 205-323-6385
 ATTN: KEITH OWENS / MARK BOGER

MECHANICAL / PLUMBING ENGINEER
 GULF STATES ENGINEERING
 600 AZALEA ROAD,
 MOBILE, AL 36609
 251-460-4648
 ATTN: CHRIS DEARMON / VAN SIMPSON

FIRE PROTECTION ENGINEER
 GULF STATES ENGINEERING
 600 AZALEA ROAD,
 MOBILE, AL 36609
 251-460-4648
 ATTN: TOM WADE / BRIAN DOVE

ELECTRICAL ENGINEER
 GULF STATES ENGINEERING
 600 AZALEA ROAD,
 MOBILE, AL 36609
 251-460-4648
 ATTN: JERRY ONWU / SID SNYDER

REV	DATE	DESCRIPTION
1	3-10-2019	ADDENDUM #1

DATE: 2-18-2019
 PROJECT: 100% CONSTRUCTION DOCUMENTS
 DRAWING FOR: Addendum #1
 DRAWN BY: DAVIS ARCHITECTS
 PROJECT NO: 3981.01

SHEET TITLE: FLOOR PLANS
 DRAWING NO.

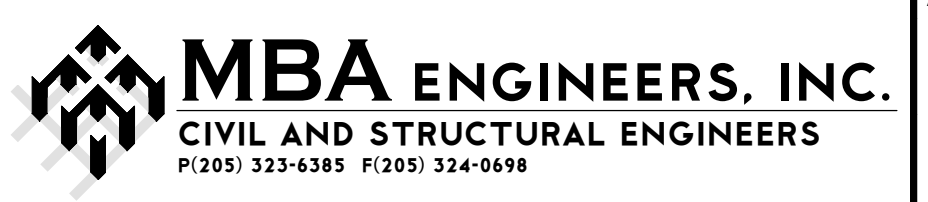

S2.01