

PUTNAM COUNTY BOARD OF COMMISSIONERS

REIDS RD/PONDER PINES RD UNPAVED

ROAD IMPROVEMENTS

REIDS ROAD

ROAD IMPROVEMENT PLAN

LAND LOTS 94, 95 & 81 - 4th DISTRICT
PUTNAM COUNTY, GEORGIA

1. PROJECT DESCRIPTION

2. PROJECT LOCATION

3. PROJECT PURPOSE

4. PROJECT SCOPE

5. PROJECT BOUNDARIES

6. PROJECT PHASES

7. PROJECT SCHEDULE

8. PROJECT COSTS

9. PROJECT BENEFITS

10. PROJECT RISKS

11. PROJECT CONTACTS

12. PROJECT APPROVALS



DATE: AUGUST 26, 2014

| NO. | DESCRIPTION | DATE | BY |
|-----|-------------|------|----|
| | | | |

13. PROJECT SPECIFICATIONS

14. PROJECT ESTIMATES

15. PROJECT NOTES

16. PROJECT COMMENTS

17. PROJECT SIGNATURES

18. PROJECT CHECKS

19. PROJECT RECORDS

20. PROJECT ARCHIVES

21. PROJECT SUMMARY

22. PROJECT CONCLUSION

23. PROJECT RECOMMENDATIONS

24. PROJECT FOLLOW-UP

25. PROJECT EVALUATION





Know what's below
Call before you dig





SHEET 14-112

CONSTRUCTION PLANS

PUTNAM COUNTY BOARD OF COMMISSIONERS
117 PUTNAM DRIVE
SUITE A
EATONTON, GEORGIA 31024
706-485-5826

TABLE OF CONTENTS
FOR
CONSTRUCTION DOCUMENTS

BIDDING DOCUMENTS

Page

| | |
|---|-------|
| Invitation to Bid | BD.2 |
| Notice to Bidders (Bid Rigging)..... | BD.3 |
| Notice to Contractors..... | BD.4 |
| Bid Proposal..... | BD.7 |
| Bid Bond..... | BD.10 |
| Certification by Contractor Regarding Non-Segregated Facilities..... | BD.12 |
| DBE Goals | BD.13 |
| Non-Collusion Affidavit of Prime Bidder | BD.14 |
| Non-Collusion Affidavit of Subcontractor..... | BD.15 |
| Affidavit Verifying Status for County Public Benefit Application..... | BD.17 |
| Certifications..... | BD.18 |
| Immigration and Security Form..... | BD.19 |
| Certification/Drug Free Work Place..... | BD.20 |
| Questionnaire..... | BD.23 |
| Subcontractor's Notification List..... | BD.27 |
| Bid Schedule of Items..... | BD.27 |

CONTRACT DOCUMENTS

SAMPLE CONTRACT AGREEMENT:

| | |
|---|-------|
| Sample Contract Agreement | CA.2 |
| 100% Performance Bond..... | CA.5 |
| 100% Labor and Material Payment Bond..... | CA.7 |
| Non-Collusion Affidavit of Subcontractor..... | CA.13 |
| Final Affidavit..... | CA.14 |
| Notice to Contractors (Compliance with Title VI)..... | CA.15 |
| Prime Contractors Work Authorization Certification..... | CA.17 |
| Subcontractors Notification List..... | CA.20 |
| Contract Schedule of Items..... | CA.21 |

GENERAL CONDITIONS:

GENERAL PROVISIONS

| | | |
|-------------|---|-------|
| Section 101 | Definition and Terms..... | GC.2 |
| Section 102 | Bidding Requirements and Conditions..... | GC.3 |
| Section 103 | Award and Execution of Contract..... | GC.6 |
| Section 105 | Control of Work..... | GC.10 |
| Section 106 | Control of Materials..... | GC.11 |
| Section 107 | Legal Regulations and Responsibility to the Public..... | GC.11 |
| Section 108 | Prosecution and Progress..... | GC.16 |
| Section 109 | Measurement and Payment..... | GC.18 |
| Section 149 | Construction Layout..... | GC.18 |
| Section 150 | Traffic Control..... | GC.19 |

CONSTRUCTION EROSION CONTROL

| | | |
|-------------|--|-------|
| Section 161 | Control of Soil Erosion and Sedimentation..... | GC.63 |
|-------------|--|-------|

SPECIAL PROVISIONS:

SCOPE OF WORK

| | |
|--------------------------|------|
| Roadways..... | SP.2 |
| Construction Issues..... | SP.2 |

SEQUENCE OF OPERATIONS

| | |
|-------------------------|------|
| General..... | SP.2 |
| Order of Work..... | SP.2 |
| Special Conditions..... | SP.3 |
| Utility Conflicts..... | SP.4 |
| Addendums..... | SP.5 |

APPENDICES:

| | |
|---|-----|
| Appendix A – Roadway Plan Set (located on county web site)..... | A.1 |
| Appendix B – Contractor’s Submitted Bidding Documents..... | A.2 |

**REIDS RD/PONDER PINES RD UNPAVED ROAD
IMPROVEMENTS**

BIDDING DOCUMENTS

For

Putnam County Board of Commissioners

INVITATION TO BID

9/16/2015

PUTNAM COUNTY, GEORGIA

REIDS RD/PONDER PINES RD UNPAVED ROAD IMPROVEMENTS

The Putnam County Board of Commissioners will be receiving sealed Bids for all material, labor, equipment and services to successfully accomplish the following work: "REIDS RD/PONDER PINES RD UNPAVED ROAD IMPROVEMENTS". Work required under the Contract includes grading, asphalt resurfacing, drainage, erosion & sedimentation control and all related materials as shown on the construction plans dated August 26th, 2014. Bids shall be on Unit Price Items.

The project shall be Substantially Complete within **120 calendar** days from the date of issuance of Notice to Proceed. Liquidated damages of \$100 per day will be assessed if work is not completed within 120 calendar days from the date of the Notice to Proceed.

Putnam County will receive bids until **2:00 PM on October 16th, 2015 at 117 Putnam Drive, Suite A, Eatonton, GA 31024; ATTN: Paul Van Haute – County Manager**. Bids received after this time will not be accepted. Bids will be opened and publicly read aloud in the Administration Building Conference Room (Room 301) at 2:15 PM on October 16th, 2015. All interested parties are invited to attend. A pre-bid conference will be held on **1:00PM, October 1st, 2015 at the Putnam County Administration Building; 117 Putnam Drive, Room 301, Eatonton, GA 31024**. All contractors are urged to attend. Apparent bid results will be available within three (3) business days on the county web site; <http://www.putnamcountyga.us>.

Bidding Documents and Construction Plans are available for download from the Putnam County Board of Commissioners web site; <http://www.putnamcountyga.us>.

Bids are legal and binding upon the bidder when submitted. All bids should be submitted in duplicate.

Award will be made to the vendor submitting the lowest responsive and responsible bid. The Putnam County Board of Commissioners reserves the right to reject any or all bids, to waive technicalities and to make an award as deemed in its best interest. The written bid documents supersede any verbal or written prior communications between the parties.

All contractors shall submit with bid, a bid bond, certified check or cashier's check in the amount of five percent (5%) of the total bid, made payable to Putnam County, Georgia. The successful contractor will be required to submit a one hundred percent (100%) performance bond and a one hundred percent (100%) payment bond. Insurance and Bonding Company must be authorized to do business in Georgia by The Georgia Insurance County, listed in the County of Treasury's Publication of Companies holding Certificates of Authority as Acceptable Surety on Federal Bonds and as acceptable reinsuring companies, and must have an A.M. Best rating of A-6 or higher.

Putnam County does not discriminate on the basis of disability in the admission or access to its programs or activities. Any requests for reasonable accommodations required by individuals to fully participate in any open meeting, program or activity of the Putnam County Government should be directed to Paul Van Haute, County Manager, Putnam County Administrative Offices, 706-485-5826.

All questions regarding the bid documents shall be made via email to the Project Manager; kaiser@co-infra-services.com. The Project Manager will acknowledge receipt of questions. If bidder does not receive acknowledgement, it's the bidder's responsibility to contact the Project Manager at 404-909-5619 to ensure questions are received. The deadline to submit questions is 5:00 PM on October 6th, 2015. The County will post "Response to Questions and/or Addendum", if applicable, on the County web site by 5:00PM on October 7th, 2015.

The **Putnam County Board of Commissioners** reserves the right to waive any informalities or irregularities, or to reject any or all bids and to re-advertise.

NOTICE TO ALL BIDDERS

To report bid rigging activities call:

1-800-424-9071

The U.S. County of Transportation (DOT) operates the above toll-free “hotline” Monday through Friday, 8:00 AM to 5:00 PM, Eastern Time. Anyone with the knowledge of possible bid rigging, bidder collusion, or other fraudulent activities should use the “hotline” to report such activities.

The “hotline” is part of the DOT’s continuing effort to identify and investigate highway construction contract fraud and abuse, and is operated under the direction of the DOT Inspector General. All information will be treated confidentially and caller anonymity will be respected.

NOTICE TO CONTRACTORS

The Putnam County Board of Commissioners will be receiving sealed Bids for all material, labor, equipment and services to successfully accomplish the following work: **“Reids Rd/Ponder Pines Rd Unpaved Improvement Project”**. Work required under the Contract includes grading, utility adjustments, asphalt resurfacing, drainage, erosion & sedimentation control and all related materials as shown on the construction plans dated March 26, 2014. Bids shall be on Unit Price Items.

The project shall be Substantially Complete within **120 calendar** days from the date of issuance of Notice to Proceed. Liquidated damages of \$200 per day will be assessed if work is not completed within 120 calendar days from the date of the Notice to Proceed.

Putnam County will receive bids until **2:00 PM on October 16th, 2015 at 117 Putnam Drive, Suite A, Eatonton, GA 31024; ATTN: Paul Van Haute – County Manager**. Bids received after this time will not be accepted. Bids will be opened and publicly read aloud in the Administration Building Conference Room (Room 301) at 2:15 PM on October 16th, 2015. All interested parties are invited to attend. A pre-bid conference will be held on **1:00PM, October 1st, 2015 at the Putnam County Administration Building; 117 Putnam Drive, Room 301, Eatonton, GA 31024**. All contractors are urged to attend. Apparent bid results will be available within three (3) business days on the county web site; <http://www.putnamcountyga.us>.

The **Work** to be done consists of the following:

Furnishing all labor, materials and equipment for the Reids Rd/Ponder Pines Rd Unpaved Road Improvement Project which includes the reconstruction of the unpaved roadway, grading, asphalt resurfacing, drainage, erosion & sedimentation control and other major construction details

The **Bidder** is required to submit the **Bid Proposal** with each part signed accordingly and the following:

1. Completed **Bid** Proposal Form Page
2. **Bid** Bond or Certified Check
3. Certification by Contractor Regarding Non-Segregated Facilities
4. Non-collusion Affidavit of Prime **Bidder**
5. Non-collision Affidavit of Subcontractor
6. Affidavit Verifying Status for County Public Benefit Application
7. Certifications
8. Immigration and Security Form
9. Certification/Drug Free Work Place
10. Questionnaire
11. Subcontractors Notification List
12. Completed **Bid** Schedule of Items

Three (3) hard copies will be required for review purposes.

All **Work** performed for this project will be in accordance with the Georgia County of Transportation (GDOT) Standard Specifications for Construction of Transportation Systems, 2001 Edition, and any modifications identified in the **Bid** or Contract documents.

This Project is funded with 100% local funds. No State or Federal funds are utilized on this project.

The **Bidder** shall be responsible for performing with his own organization at least Sixty percent (60%) of the **Work** in this contract. The **Bidder** shall not subcontract, transfer, assign, or otherwise dispose of the contract or any portion thereof, without the written consent of the County.

Bidders are NOT required to have pre-qualified with the Georgia County of Transportation to bid on this project although experience with similar projects that adhere to GDOT standards and regulations is highly recommended. **Bidder** shall possess a current Utility Contractors License with the Georgia Secretary of State.

The successful **Bidder** shall secure and pay for necessary approvals, permits, assessments, and changes required for the construction and installation of this project as required by local, state, and federal regulations.

Bidders must comply with Title VI of the Civil Rights Act of 1964, the Anti-Kickback Act, the Contract Work Hour Standard Act, and the National Occupational Safety and Health Act of 1970.

Bidders must certify that they do not and will not maintain or provide for their employees any facilities that are segregated on a basis of race, color, creed, or national origin.

The Putnam County Board of Commissioners reserves the right to reject all **Bids** and to waive formalities. Any claims for cost incurred by any **Bidder** in preparation of any part of or total package for this project will not be considered for reimbursement by Putnam County.

Bidders must complete the DBE Goals List in order to comply with the goal to provide a minimum of 5% Disadvantage Business Enterprise (DBE/WBE/MBE) participation on this project. A DBE Subcontractor must have a current DBE certification by GDOT in order to be considered as part of the 5% DBE goal. This is a goal and not a requirement, but an explanation stating reasons for not complying with the goal must be submitted.

The Construction Documents consist of the following, including all addenda issued therewith and forms referenced therein:

Bidding Documents
Sample Contract Agreement
General Conditions
Special Provisions
Appendices

The roadway plans, prepared by Patrick & Associates, Inc. and dated August 26th, 2014 are available for download from the Putnam County web site.

All questions concerning this invitation and all questions arising subsequent to award are to be addressed to the following address:

Collaborative Infrastructure Services, Inc.
Attn: Larry Kaiser, P.E.
945 Bank Street; Suite 200
Conyers, GA 30012
Phone: (404)909-5619
Email: kaiser@co-infra-services.com

TORT IMMUNITY:

No officer, employee, or agent of the County acting within the scope of his/her employment or function shall be held personally liable in tort or named as a defendant in any action for injury or damage suffered because of any act, event, or failure to act.

SILENCE OF SPECIFICATIONS

The apparent silence of these specifications and any supplemental specifications as to any details, or the omission from it of a detailed description concerning any point, shall be regarded as meaning that only the best commercial practices are to prevail and that only materials of first quality and correct type, size and design are to be used. All workmanship is to be first quality. All interpretations of this specification shall be made upon the basis of this statement, with County interpretation to prevail.

OPTION TO AUDIT

Successful bidder will be required to maintain complete records during the life of the contract and for a period of one year after completion of the contract. Such records are to be made available to the County if officially requested, to be audited by a designated County auditing staff. In such audits reveal overcharges and/or undercharges, such will be adjusted and compensation made by either party to correct charges.

BID PROPOSAL, page 1 of 3

Proposal of _____(hereinafter called "**Bidder**"), a contractor organized and existing under the laws of the State of Georgia, *an individual, a corporation, a partnership doing business as: _____ :

TO: Putnam County
(Hereinafter called "**County**")

Gentlemen:

The **Bidder** in compliance with your Notice to Contractors and all Bidding Documents for the following work:

Furnishing all labor, materials and equipment for the Reids Rd/Ponder Pines Rd Unpaved Road Improvement Project which includes the reconstruction of the unpaved roadway, grading, asphalt resurfacing, drainage, erosion & sedimentation control and other major construction details

Having examined the plans and specifications with related documents and the site of the proposed **Work**, and being familiar with all of the conditions surrounding the construction of the proposed projects, including the availability of materials and supplies to construct the projects in accordance with the contract documents, within the time set forth herein, and at the prices stated below, proposes to enter into a Contract with Putnam County to provide the necessary machinery, tools, apparatus, all materials and labor, and other means of construction necessary to complete the **Work**. The undersigned proposes to furnish and construct the items listed in the attached Schedule of Items for the unit prices stated.

Bidder agrees that the cost of any **Work** performed, materials furnished, services provided or expenses incurred, which are not specifically delineated in the Contract Documents, but which are incidental to the scope, intent, and completion of the Contract, shall be deemed to have been included in the prices **Bid** for the various items scheduled.

Bidder further proposes and agrees hereby to promptly commence the **Work** with adequate force and equipment within ten (10) calendar days from receipt of Notice to Proceed, or as may be specified by Special Provision, and to complete the **Work by 120 calendar days from the Notice to Proceed Date**, or as may be specified by Special Provisions.

BID PROPOSAL, page 2 of 3

Bidder assumes the responsibility to download all addenda published on the Putnam County website prior to submittal of his **Bid**, and accepts that failure to acknowledge receipt of each and every addendum individually is grounds for finding the **Bid** non-responsive. **Bidder** hereby acknowledges receipt of the following addenda:

The undersigned further agrees that in case of failure on his part to execute said contract and bond, or provide satisfactory proof of carriage of the insurance required, within ten (10) calendar days after the award thereof, the **Bid Bond** or certified check accompanying his **Bid** and the money payable thereon shall be forfeited to the **County** as liquidated damages; otherwise, the check or Bond accompanying this proposal shall be returned to the **Bidder**.

The **Bidder** declares that he understands that the quantities shown on the proposal are subject to adjustment by either increase or decrease, and that should the quantities of any of the items of **Work** be increased, the undersigned proposes to do the additional **Work** at the unit prices stated herein; and should the quantities be decreased, he also understands that payment will be made on actual quantities at the unit price **Bid** and will make no claim for anticipated profits for any decrease in the quantities, and that actual completed, final quantities will be determined upon completion of **Work** and acceptance by the **County**, at which time adjustment will be made to the Contract amount by direct increase or decrease.

Attached hereto is a **Bid** bond or certified check on the (Bank) _____ in the amount of _____, (Five percent (5%) of Total Amount **Bid**).

The full name and residence of persons or parties interested in the foregoing **Bid** as contractors are named as follows:

BID PROPOSAL, page 3 of 3

Putnam County, Georgia

Signed, sealed, and dated this _____ day of _____, 20____ .

Bidder: _____
(Company Name)

By: _____

Title: _____

Mailing Address:

BID BOND, page 1 of 2

Five Percent (5%) of **Bid**

KNOW ALL MEN BY THESE PRESENTS, that we, the undersigned

_____, as **Contractor**, and

_____, as **Surety**, are

hereby held and firmly bound unto PUTNAM COUNTY, GEORGIA, as **County**, in the penal sum of

(\$ _____) for the payment of which, well and truly to be made, we hereby

joint and severally bind ourselves, our heirs, executors, administrators, successors, and assigns

Signed this _____ day of _____, 20 _____.

The condition of the above obligation is such that whereas the **Contractor** has submitted to PUTNAM COUNTY, GEORGIA a certain **Bid** attached hereto and hereby made a part hereof to enter into a contract in writing for the following work:

Furnishing all labor, materials and equipment for the Reids Rd/Ponder Pines Rd Unpaved Road Improvement Project which includes the reconstruction of the unpaved roadway, grading, asphalt resurfacing, drainage, erosion & sedimentation control and other major construction details

NOW, THEREFORE,

- (a) If said **Bid** shall be rejected or in the alternate,
- (b) If said **Bid** shall be accepted and the **Contractor** shall execute and deliver a Contract in the Form of Contract attached hereto (properly complete in accordance with said **Bid**) and shall furnish a bond for his faithful performance of said Contract and for the payment of all persons performing labor or furnishing material in connection therewith, and shall in all other respects perform the agreement created by the acceptance of said **Bid**, then this obligation shall be void, otherwise the same shall remain in force and effect; it being expressly understood and agreed that the liability of the **Surety** for any and all claims hereunder shall, in no event, exceed the penal amount of this obligation as herein stated.

The **Surety**, for value received, hereby stipulates and agrees that the obligations of said **Surety** and its bond shall be in no way impaired or affected by any extension of the time within which the **County** may accept such **Bids**, and said **Surety** does hereby waive notice of any such extension.

BID BOND, page 2 of 2

IN WITNESS WHEREOF, the **Contractor** and the **Surety** have hereunto set their hands and seals, and such of them as are corporations have caused their corporate seals to be hereto affixed and these presents to be signed by their proper officers, the day and year first set forth above.

_____ (SEAL)
Contractor

By: _____

_____ (SEAL)
Surety_____

By: _____

CERTIFICATION BY CONTRACTOR
Regarding
NON-SEGREGATED FACILITIES

The **Bidder** certifies that he does not, and will not, provide and maintain segregated facilities for his employees at his establishments and, further that he does not, and will not, permit his employees to perform their services at those locations, under his control, where segregated facilities are provided and maintained. Segregated facilities include, but are not necessarily limited to, drinking fountains, transportation, parking, entertainment, recreation, and housing facilities; waiting, rest, wash, dressing, and locker rooms, and time clock, **Work**, storage, restaurant, and other eating areas which are set apart in fact, or by explicit directive, habit, local custom, or otherwise, on the basis of color, creed, national origin, and race. The **Bidder** agrees that, except where he has obtained identical certifications from proposed subcontractors for specific time periods, he will obtain identical certifications from proposed subcontractors prior to the award of subcontracts exceeding \$10,000.00 which are not exempt from the provisions of the Equal Opportunity clause, and that he will retain such certifications in his files.

The **Bidder** agrees that a breach of this certification is a violation of the Equal Opportunity clause in this Contract. The penalty for making false statements is prescribed in 18 U.S.C. 1001.

Bidder (Print)

(Signature)

Name of Signer (Print)

Title of Signer

Date

DBE GOALS

GDOT VENDOR ID: _____ BIDDER'S COMPANY NAME: _____

COUNTY: #15-1 PUTNAM COUNTY

LET NO: NA LET DATE: _____ TOTAL BID:

THE REQUIRED DBE GOAL ON THIS CONTRACT IS: 5%

PROPOSE TO UTILIZE THE FOLLOWING DBE'S:

LIST OF DBE PARTICIPANTS

| DBE NAME/ADDRESS (CITY, STATE) | TYPE OF WORK | DBE/WBE/MBE CERTIFICATION # (Georgia Department of Transportation) | AMOUNT |
|-----------------------------------|-----------------|---|--------|
| | | | |
| | | | |
| | | | |
| | | | |
| | | | |
| | | | |
| | | | |
| | | | |
| | | | |
| | | | |
| | | | |
| | | | |
| | | | |
| | | | |
| | | | |
| | | | |
| | | | |
| | | | |
| | | | |

TOTAL: \$ _____

NON-COLLUSION AFFIDAVIT OF PRIME BIDDER

State of _____)

County of _____)

_____, being first duly sworn, deposes and says that:

1. He is _____ (Owner, Partner, Officer, Representative, or Agent) of the **Bidder** that has submitted the attached **Bid**;
2. He is fully informed respecting the preparation and contents of the attached **Bid** and of all pertinent circumstances respecting such **Bid**;
3. Such **Bid** is genuine and is not a collusive or sham **Bid**;
4. Neither the said **Bidder** nor any of its officers, partners, owners, agents, representatives, employees, or parties in interest, including this affiant, has in any way colluded, conspired, connived, or agreed, directly or indirectly, with any other **Bidder**, firm or person to submit a collusive or sham **Bid** in connection with the Contract for which the attached **Bid** has been submitted to or refrain from bidding in connection with such Contract, or has in any collusion or communication or conference with any other **Bidder**, firm or person to fix the price or prices in the attached **Bid** or of any other **Bidder**, or to fix any overhead, profit or cost element of the **Bid** price or the **Bid** price of any other **Bidder**, or to secure through any collusion, conspiracy, connivance or unlawful agreement any advantage against Putnam County or any person interested in the proposed Contract; and,
5. The price or prices quoted in the attached **Bid** are fair and proper and are not tainted by any collusion, conspiracy, connivance, or unlawful agreement on the part of the **Bidder** or any of its agents, representatives, owners, employees, or parties in interest, including this affiant.

(Signed) _____

Name _____(Print)

Title _____(Print)

Subscribed and Sworn to before me
this _____ day _____ 20__ .

(SEAL)

Title

NON-COLLUSION AFFIDAVIT OF SUBCONTRACTOR

State of _____)

County of _____)

_____, being first duly sworn, deposes
and says that:

1. He is _____ (Owner, Partner, Officer, Representative, or Agent) of the **Bidder** that has submitted the attached **Bid**;
2. He is fully informed respecting the preparation and contents of the attached **Bid** and of all pertinent circumstances respecting such **Bid**;
3. Such **Bid** is genuine and is not a collusive or sham **Bid**;
4. Neither the said **Bidder** nor any of its officers, partners, owners, agents, representatives, employees, or parties in interest, including this affiant, has in any way colluded, conspired, connived, or agreed, directly or indirectly, with any other **Bidder**, firm or person to submit a collusive or sham **Bid** in connection with the Contract for which the attached **Bid** has been submitted to or refrain from bidding in connection with such Contract, or has in any collusion or communication or conference with any other **Bidder**, firm or person to fix the price or prices in the attached **Bid** or of any other **Bidder**, or to fix any overhead, profit or cost element of the **Bid** price or the **Bid** price of any other **Bidder**, or to secure through any collusion, conspiracy, connivance or unlawful agreement any advantage against Putnam County or any person interested in the proposed Contract; and,
5. The price or prices quoted in the attached **Bid** are fair and proper and are not tainted by any collusion, conspiracy, connivance, or unlawful agreement on the part of the **Bidder** or any of its agents, representatives, owners, employees, or parties in interest, including this affiant.

(Signed) _____

Name _____(Print)

Title _____(Print)

Subscribed and Sworn to before me
this _____ day of _____ 20_____ .

(SEAL)

Title

**Affidavit Verifying Status
for County Public Benefit Application**

By executing this affidavit under oath, as an applicant for the award of a contract with Putnam County Georgia, I _____ [Name of natural person applying on behalf of

individual, business, corporation, partnership, or other private entity] am stating the following as required by O.C.G.A. Section 50-36-1:

1) _____ I am a United States citizen

OR

2) _____ I am a legal permanent resident 18 years of age or older or I am an otherwise

qualified alien or non-immigrant under the Federal Immigration and Nationality Act 18 years of age or older and lawfully present in the United States.*

In making the above representation under oath, I understand that any person who knowingly and willfully makes a false, fictitious, or fraudulent statement or representation in an affidavit shall be guilty of a violation of Code Section 16-10-20 of the Official Code of Georgia.

Date

Signature of Applicant:

Printed Name:

*_____
Alien Registration number for non-citizens

SUBSCRIBED AND SWORN
BEFORE ME ON THIS THE
_____ DAY OF _____, 20____ .

Notary Public
My commission Expires:

***Note:** O.C.G.A. § 50-36-1(e)(2) requires that aliens under the federal Immigration and Nationality Act, Title 8 U.S.C., as amended, provide their registration number. Because legal permanent residents are included in the federal definition of "alien", legal permanent residents must also provide their alien registration number. Qualified aliens that do not have an alien registration number may supply another identifying number below.

CERTIFICATIONS**Page 1 of 2**

Failure to complete appropriate certification requirements identified below or submission of a false certification shall render the **Bid** non-responsive.

EXAMINATION OF PLANS AND SPECIFICATIONS

I certify that I have carefully examined the Construction Documents for this project and the Georgia County of Transportation Standard Specifications, 2001 Edition, and the Supplemental Specifications and Special Provisions included in and made a part of this Proposal, and have also personally examined the sites of the **Work**. On the basis of the said Specifications and Documents, I proposed to furnish all necessary labor, machinery, tools, apparatus and other means of construction, and do all the **Work** and furnish all the materials in the manner specified.

I understand that any quantities mentioned or provided are approximate only and are subject to either increase or decrease and hereby propose to perform any increased or decreased quantities of **Work** or extra **Work** on the basis provided for in the specifications.

I also hereby agree that Putnam County would suffer damages in a sum equal to at least the amount of the enclosed Proposal Guaranty, in the event my Proposal should be accepted and a Contract tendered me thereunder and I should refuse to execute same and furnish bond as herein required, in consideration of which I hereby agree that, in the event of such failure on my part to execute said Contract and furnish bond within ten (10) days after the date of the letter transmitting the Contract to me, the amount of said Proposal Guaranty shall be and is hereby, forfeited to Putnam County as liquidated damages as the result of such failure on my part.

I further propose to execute the Contract agreement described in the Specifications as soon as the **Work** is awarded to me, and to begin and complete the **Work** within the time limit provided. I also propose to furnish a Contract Bond, approved by the Putnam County Board of Commissioners as required by the laws of the State of Georgia. This bond shall not only service to guarantee the excellence of both workmanship and materials until the **Work** is finally accepted, as well as to fully comply with all the laws of the State of Georgia.

CERTIFICATIONS
page 2 of 2

CONFLICT OF INTEREST

By signing and submitting this Contract I hereby certify that employees of this company or employees of any company supplying material or subcontracting to do **Work** on this Contract will not engage in business ventures with employees of Putnam County or Consulting firm Collaborative Infrastructure Services, Inc., shall they provide gifts, gratuities, favors, entertainment, loans or other items of value to employees of this County.

Also, by signing and submitting this Contract, I hereby certify that I will notify Putnam County through its County Manager of any business ventures entered into between employees of this company or employees of any company supplying material or subcontracting to do **Work** on this Contract with a family member of Putnam County employees.

Contractor

(Signature)

Name of Signer

Title of Signer

Date

IMMIGRATION AND SECURITY FORM

O.C.G.A. § 13-10-91 requires contractors interested in public works contracts to file an affidavit that the contractor and its subcontractors have registered and participate in a federal work authorization program intended to insure that only lawful citizens or lawful immigrants are employed by the contractor or subcontractor.

In order to insure compliance with the Immigration Reform and Control Act of 1986 (IRCA), D.L. 99-603 and the Georgia Security and Immigration Compliance Act OCGA 13-10-90 et.seq., Contractor must warrant and affirm that Contractor has complied with the Immigration Reform and Control Act of 1986 (IRCA), D.L. 99-603 and the Georgia Security and Immigration Compliance Act by registering at <https://e-verify.uscis.gov/enroll/StartPage.aspx?JS=YES>; and verifying information of all new employees; and by executing any affidavits required by the rules and regulations issued by the Georgia County of Labor set forth at Rule 300-10-1-.01 et.seq.

By executing this affidavit, the undersigned Contractor verifies its compliance with O.C.G.A. § 13-10-91, stating affirmatively that the individual, firm, or corporation which is contracting with Putnam County, Georgia has registered with and is participating in a federal work authorization program [any of the electronic verification of work authorization programs operated by the United States County of Homeland Security or any equivalent federal work authorization program operated by the United States County of Homeland Security to verify information of newly hired employees, pursuant to the Immigration Reform and Control Act of 1986 (IRCA), P.L. 99-603], in accordance with the applicability provisions and deadlines established in O.C.G.A. § 13-10-91, and Contractor warrants that it will continue to use the federal work authorization program throughout the contract period.

The undersigned further agrees that, should it employ or contract with any subcontractor(s) in connection with the physical performance of services pursuant to this contract with Putnam County, Georgia, Contractor will secure from such subcontractor(s) similar verification of compliance with O.C.G.A. § 13-10-91 on the Subcontractor Affidavit provided in Georgia County of Labor Rule 300-10-01-.08 or a substantially similar form. Contractor further agrees to maintain records of such compliance and provide a copy of each such verification to Putnam County, Georgia at the time the subcontractor(s) is retained to perform such service.

Signature Title

Firm Name: _____

Street/Mailing Address: _____

City, State, Zip Code: _____

Telephone Number: _____

Email: _____

Employer Identification Number: _____

Date of Authorization: _____

CERTIFICATION OF SPONSOR DRUG-FREE WORKPLACE

I hereby certify that I am a principle and duly authorized representative or _____
_____ whose address is _____
_____ and it is also that:

1. The provisions of Section 50-24-1 through 50-24-6 of the Official Code of Georgia Annotated, relating to the "Drug-Free Workplace Act" have been complied with in full; and,
2. A drug-free workplace will be provided for the sponsor's employees during the performance or the contract; and,
3. Each subcontractor hired by the SPONSOR shall be required to ensure that the subcontractor's employees are provided a drug-free workplace. The SPONSOR shall secure from that subcontractor the following written certification: "As part of the subcontracting agreement with _____
_____ certifies to the SPONSOR that a drug-free workplace will be provided for the subcontractor's employees during the performance of this contract pursuant to paragraph (7) of subsection (b) of the Official Code of Georgia Annotated Section 50-24-3; and,
4. It is certified that the undersigned will not engage in unlawful manufacture, sale, distribution, dispensation, possession, or use of a controlled substance or marijuana during the performance of the contract.

Date: _____

Signature: _____

**DEPARTMENT OF TRANSPORTATION
STATE OF GEORGIA**

NON-COLLUSION CERTIFICATION

I hereby certify that I have not, nor has any member of the firm(s) or corporation(s), either directly or indirectly entered into any agreement, participated in any collusion, nor otherwise taken any action in restraint of free competitive bidding in connection with this submitted bid.

It is understood and agreed that this Proposal is one of several competitive bids made to the Department of Transportation, and in consideration of mutual agreements of the bidders, similar hereto, and in consideration of the sum of One Dollar cash in hand paid, receipt whereof is hereby acknowledged, the undersigned agrees that this Proposal shall be an option, which is hereby given by the undersigned to the Department of Transportation to accept or reject this Proposal at any time within thirty (30) calendar days from the date on which this sealed proposal is opened and read, unless a longer period is specified in the Proposal or the successful bidder agrees in writing to a longer period of time for the award, and in consideration of the premises, it is expressly covenanted and agreed that this Proposal is not subject to withdrawal by the Proposer or Bidder, during the term of said option.

I hereby acknowledge receipt of the following checked amendments of the Proposal, Plans, Specifications and/or other documents pertaining to the Contract.

Amendment Nos.: 1 2 3 4 5 . I understand that failure to confirm the receipt of amendments is cause for rejection of bids.

Witness my hand and seal this the _____ day of _____, 20_____.

The bidder(s) whose signature(s) appear on this document, having personally appeared before me, and being duly sworn, deposes and says that the above statements are true and correct.

Sworn to and subscribed before me this _____ day of _____, 20_____.

(Notary Public)

My Commission expires the _____ day of _____, 20_____.

(Federal ID No./IRS No.)

(Print Company Name)
By _____ (Seal)
Corporate President/Vice President or
Individual Owner or Partner (Strike
through all except the one which applies.)

Joint Bidder:

(Print Company Name)
By _____ (Seal)
Corporate President/Vice President or
Individual Owner or Partner (Strike
through all except the one which applies.)

Joint Bidder:

(Print Company Name)
By _____ (Seal)
Corporate President/Vice President or
or Individual Owner or Partner (Strike
through all except the one which applies.)

QUESTIONNAIRE

Project Name: Reids Rd/Ponder Pines Rd Unpaved Improvement Project

Date: _____
(PLEASE ATTACH SEPARATE SHEETS AS NECESSARY)

*****ALL QUESTIONS MUST BE ANSWERED THOROUGHLY BY THE BIDDER. DO NOT LEAVE ANY QUESTION BLANK. MARK N/A IF NOT APPLICABLE. FAILURE TO THOROUGHLY ANSWER ALL QUESTIONS MAY RESULT IN DELAY OF CONTRACT OR DISQUALIFICATION OF THE BIDDER. *****
PLEASE RETURN COMPLETED QUESTIONNAIRE WITH THE BID SUBMITTAL

A. GENERAL INFORMATION

1. How many years has your organization been in business as a Contractor performing roadway construction? _____
2. State the true and exact, correct, and complete name under which you do business.

3. How many years has your organization been in business under its present name? _____
4. Under what other or former names has your organization operated? _____

5. State the true and exact, correct, and complete address of facility where service will be provided from.

B. EXPERIENCE

1. Briefly describe the nature and contract value of projects typically executed by your organization.

2. On a separate sheet, list a minimum of three projects that you have completed similar in type, size, and nature as the one proposed. Preference should be given to county/state/federal projects. Provide the following information for each project:
 - Name of Project: _____
 - Owner: _____
 - Contact and Phone Number: _____
 - Address: _____
 - Engineer _____
 - Contact and Phone Number: _____
 - Address: _____
 - Date Started: _____
 - Date Completed: _____
 - Project Superintendent: _____
 - Value of Contract: _____
 - Description of Project: _____

3. Attach qualifications and experience for proposed key personnel who will be assigned to the project if awarded, including: Project Managers, Superintendents, Foreman, Technicians, and Engineer's, etc.
4. Describe the typical organization of staff assigned to a project executed by your firm (including the number/level of supervisory staff per number of workers).
5. What equipment do you own that you will use for this Work? Attach a detailed list. Include make, model and year of manufacture of each piece of equipment.
6. What equipment will be leased or rented for use on this Project? Attach a detailed list.
7. Attach a description of your firm's training program in Health and Safety for employees over the past year. Note dates, instructions, location and overall content of program.
8. Provide information on your organization's safety record for the past three years.
9. Provide at least three (3) references familiar with roadway construction projects you have completed in the past five (5) years. Preference should be given to county/city/state/federal projects. References should not be a current employee or subcontractor that will be utilized by your firm.

Reference #1

- a. Organization Name: _____
- b. Description of Project: _____
- c. Contract Period: _____
- d. Contact Person/Title: _____
- e. Phone Number: _____

Reference #2

- a. Organization Name: _____
- b. Description of Project: _____
- c. Contract Period: _____
- d. Contact Person/Title: _____
- e. Phone Number: _____

Reference #3

- a. Organization Name: _____
- b. Description of Project: _____
- c. Contract Period: _____
- d. Contact Person/Title: _____
- e. Phone Number: _____

C. PERFORMANCE AND COMMITMENTS

1. Has your organization ever failed to complete work awarded to you? If so, where, when, and why?

2. Has your organization filed a construction claim against the Owner on any work awarded to you within the last five years? If so, where, when, and why?

3. Has your organization filed a construction claim against CIS Inc. or Putnam County on any work awarded to you within the last five years? If so, where, when, and why?

4. Has your organization had to pay liquidated damages on any work awarded to you within the last five years? If so, where, when, and why?

5. Have you ever been involved in litigation regarding work awarded to you as a prime Contractor or Subcontractor?

6. On a separate sheet, list major projects your organization has in progress, giving the name of the project, owner, architect/CIS. Inc, contract amount, percent complete, and scheduled completion date.

D. FINANCIAL INFORMATION

1. If a private company, the Offeror shall provide a copy of their (2) two most recent year's internal financial statements, and a letter from their financial institution, on the financial institutions letterhead, stating the Offeror's financial stability.
2. If a public company, the Offeror shall provide a copy of their last (2) two years audited financial statements.

D. OTHER INFORMATION

Provide other information to illustrate your qualifications to do the Work (Include attachments as applicable).

The undersigned all statements and answers contained herein are true, complete, and accurate to the best of your knowledge.

Date Questionnaire Submitted: _____

Name of Organization _____

Authorized Signature _____

Name & Title of Signer (Printed) _____

Business Address _____

Phone Number

Fax Number _

END QUESTIONNAIRE

SUBCONTRACTORS NOTIFICATION LIST

Required information on Subcontractors doing work in Putnam County:

Please list any Subcontractors, the address, Business License number, scope of work and start date, and percent of work assigned for each Subcontractor who may be doing work in the County.

General Contractor: _____

State License Number: _____

Subcontractor: _

License Number:

Start Date: _

Scope of Work:

Percent of Work: _

Subcontractor: _

License Number:

Start Date: _

Scope of Work: _

Percent of Work: _

Subcontractor: _

License Number:

Start Date: _

Scope of Work: _

Percent of Work: _

Subcontractor: _

License Number:

Start Date: _

Scope of Work: _

Percent of Work: _

Subcontractor: _

License Number:

Start Date: _

Scope of Work: _

Percent of Work: _

REID ROAD/PONDER PINES ROAD UNPAVED ROAD IMPROVEMENT PROJECT

BID SCHEDULE OF ITEMS

Contract Scope: Furnishing all labor, materials and equipment for the Reids Rd/Ponder Pines Rd Unpaved Road Improvement Project which includes the reconstruction of the unpaved roadway, grading, asphalt resurfacing, drainage, erosion & sedimentation control and other major construction details

Vendor: _____

Signature: _____

PUTMAN COUNTY – SECTION A

| No. | Pay Item No. | Item | Approx. Quantity | Unit | Unit Price | Amount |
|------------------------|--------------|--|------------------|------|------------|--------|
| TRAFFIC CONTROL | | | | | | |
| 1 | 150-1000 | TRAFFIC CONTROL | 1.0 | LS | | |
| 2 | 151-1000 | MOBILIZATION | 1.0 | LS | | |
| EARTHWORK | | | | | | |
| 3 | 210-1500 | CLEARING AND GRUBBING | 1.0 | LS | | |
| 4 | 210-0100 | GRADING COMPLETE | 1.0 | LS | | |
| PAVEMENT ITEMS | | | | | | |
| 5 | 310-5040 | GRADED AGGREGATE BASE COURSE; 4 IN INCL MAT | 5528 | SY | | |
| 6 | 310-5060 | GRADED AGGREGATE BASE COURSE; 6 IN INCL MAT | 3785 | SY | | |
| 7 | 402-3113 | RECY ASPH CONC 9.5 mm SUPERPAVE, TYPE II, BLEND 1, INCL BIT, MATL AND H LIME | 777 | TN | | |
| 8 | 402-3141 | RECL ASPH CONC 12.5 mm SUPERPAVE, GP 1 OR GP 2 INCL BIT MATL AND H LIME | 1035 | TN | | |
| 9 | 402-3190 | RECL ASPH CONC 19 mm SUPERPAVE GP 1 OR GP 2, INCL BIT MATL AND H LIME | 1554 | TN | | |
| 10 | 413-1000 | BITUMINOUS TACK COAT | 2343 | GL | | |
| DRAINAGE ITEMS | | | | | | |

| | | | | | | |
|------------------------------|----------|---|-----------|----|--|--|
| 11 | 550-1240 | STORM DRAIN PIPE, 24 IN. H 1-10 FT. (RCP) | 95 | LF | | |
| 12 | 550-3324 | SAFETY END SECTION, 24 IN. STORM DRAIN, 4:1 SLOPE | 4 | EA | | |
| 13 | 610-1880 | REM STORM DRAIN PIPE | 71 | LF | | |
| SIGNING & MARKING | | | | | | |
| 14 | 636-1029 | HIGHWAY SIGNS, TP 2, MATL, REFL SHEETING, TP 3 | 3 | EA | | |
| 15 | 636-2010 | GALV STEEL POST, TP 1 | 3 | EA | | |
| 16 | 653-1501 | THERMOPLASTIC SOLID TRAFFIC STRIPE, 5 IN. WHITE | 6260 | LF | | |
| 17 | 653-1502 | THERMOPLASTIC SOLID TRAFFIC STRIPE, 5 IN. YELLOW | 6340 | LF | | |
| 18 | 653-1704 | THERMOPLASTIC SOLID TRAFFIC STRIPE, 24 IN. WHITE | 38 | LF | | |
| 19 | 653-2810 | THERMOPLASTIC SKIP TRAFFIC STRIPE, 10 IN. WHITE | 420 | LF | | |
| 20 | NA | RELOCATE SIGN ALL SIZES | 1 | EA | | |
| EROSION CONTROL | | | | | | |
| 21 | 163-0527 | CONSTRUCT & REMOVE RIP RAP CHECK DAMS | 8 | EA | | |
| 22 | 163-0232 | TEMPORARY GRASSING | 2.21 | AC | | |
| 23 | 165-0030 | MAINTENANCE OF TEMP SILT FENCE; TYPE C | 560 | LF | | |
| 24 | 165-0041 | MAINTENANCE OF RIP RAP CHECK DAMS; ALL TYPES | 8 | EA | | |
| 25 | 171-0010 | TEMPORARY SILT FENCE, TYPE A | 560 | LF | | |
| 26 | 603-1018 | STONE DUMPED RIP RAP, 18 IN. | 150 | SY | | |
| 27 | 700-6910 | PERMANENT GRASSING | 2.21 | AC | | |
| 28 | 700-7000 | AGRICULTURAL LIME (3000 LBS/AC) | 1.70 | TN | | |
| 29 | 700-8000 | MIXED GRADE FERTILIZER (1500 LBS/AC) | 1.70 | TN | | |
| 30 | 700-8100 | FERTILIZER NITROGEN CONTENT (100 LBS/AC) | 220 | | | |
| SUBTOTAL TOTAL | | | \$ | | | |

MORGAN COUNTY - SECTION B

| No. | Pay Item No. | Item | Approx. Quantity | Unit | Unit Price | Amount |
|------------------------------|--------------|--|------------------|------|------------|--------|
| TRAFFIC CONTROL | | | | | | |
| 1 | 150-1000 | TRAFFIC CONTROL | 1. | LS | | |
| 2 | 151-1000 | MOBILIZATION | 1. | LS | | |
| EARTHWORK | | | | | | |
| 3 | 210-1500 | CLEARING AND GRUBBING | 1. | LS | | |
| 4 | 210-0100 | GRADING COMPLETE | 1 | LS | | |
| PAVEMENT ITEMS | | | | | | |
| 5 | 310-5040 | GRADED AGGREGATE BASE COURSE; 4 IN INCL MAT | 222 | SY | | |
| 6 | 310-5060 | GRADED AGGREGATE BASE COURSE; 6 IN INCL MAT | 1195 | SY | | |
| 7 | 402-3113 | RECY ASPH CONC 9.5 mm SUPERPAVE, TYPE II, BLEND 1, INCL BIT, MATL AND H LIME | 118 | TN | | |
| 8 | 402-3141 | RECL ASPH CONC 12.5 mm SUPERPAVE, GP 1 OR GP 2 INCL BIT MATL AND H LIME | 158 | TN | | |
| 9 | 402-3190 | RECL ASPH CONC 19 mm SUPERPAVE GP 1 OR GP 2, INCL BIT MATL AND H LIME | 236 | TN | | |
| 10 | 413-1000 | BITUMINOUS TACK COAT | 357 | GL | | |
| SIGNING & MARKING | | | | | | |
| 11 | NA | SIGN RELOCATION; ALL SIZES | 1 | EA | | |
| 12 | 610-6515 | REM HIGHWAY SIGN, STD | 2 | EA | | |
| 13 | 636-1029 | HIGHWAY SIGNS, TP 2 MATL, REFL SHEETING, TP3 | 2 | EA | | |
| 14 | 636-2010 | GALV STEEL POSTS, TP1 | 2 | EA | | |
| 15 | 653-1501 | THERMOPLASTIC SOLID TRAFFIC STRIPE, 5 IN. WHITE | 1065 | LF | | |
| 16 | 653-1502 | THERMOPLASTIC SOLID TRAFFIC STRIPE, 5 IN. YELLOW | 1065 | LF | | |
| EROSION CONTROL | | | | | | |
| 17 | 163-0232 | TEMPORARY GRASSING | .34 | AC | | |
| 18 | 700-6910 | PERMANENT GRASSING | .34 | AC | | |
| 19 | 700-7000 | AGRICULTURAL LIME (3000 LBS/AC) | .25 | TN | | |
| 20 | 700-8000 | MIXED GRADE FERTILIZER (1500 LBS/AC) | .25 | TN | | |
| 21 | 700-8100 | FERTILIZER NITROGEN CONTENT (100 LBS/AC) | 33 | LB | | |

| | |
|------------------|----|
| SUB-TOTAL | \$ |
|------------------|----|

TOTAL BID (Section A + B) = \$ _____

Name of Contractor: _____ Company Repr: _____ Date: _____

PUTNAM COUNTY, GEORGIA

PROJECT #15-1

**REIDS RD/PONDER PINES RD UNPAVED
IMPROVEMENT PROJECT**

CONTRACT AGREEMENT

Putnam County Board of Commissioners

CONTRACT AGREEMENT

(page 1 of 2)

THIS AGREEMENT made by and between **PUTNAM COUNTY, GEORGIA**, hereinafter called "**County**", and _____, a contractor doing business as a corporation of the City of _____, County of _____ and State of Georgia, hereinafter called "**Contractor**".

WITNESSETH: that for and in consideration of the payments and agreements hereinafter mentioned, to be made and performed by the **County**, the **Contractor** hereby agrees to commence and complete the construction described as follows:

Furnishing all labor, materials and equipment for the Reids Rd/Ponder Pines Rd Unpaved Road Improvement Project which includes the reconstruction of the unpaved roadway, grading, asphalt resurfacing, drainage, erosion & sedimentation control and other major construction details

hereinafter called the "Project", for the sum of : _____ **And** _____ **Cents** (\$_____) and all extra work in connection therewith, under the terms as stated in the General Conditions, Special Provisions, Appendices and Detailed Specifications of the Contract, and at **Contractor's** own cost and expense necessary to furnish all materials, supplies, machinery, equipment, tools, superintendence, labor, insurance, and other accessories and services to complete the said project in accordance with the conditions and prices stated in the proposal, the General Conditions, Special Provisions, Appendices, and Detailed Specifications of the Contract, the plans (prepared by Patrick & Associates, Inc. dated 4/26/2014), which include all explanatory matter thereof, as prepared by Putnam County, the specifications and contract documents as enumerated in Section 105.04 of the General Conditions, hereinafter called the "**Work**", all of which are made a part hereof and collected constitute the Contract.

The **Contractor** shall promptly commence the Work with adequate force and equipment within TEN (10) calendar days from receipt of Notice to Proceed, or as may be specified by Special Provision, and to complete the Work by **120 CALENDAR DAYS FROM THE NOTICE TO PROCEED DATE** or as may be specified by Special Provision.

The **County** agrees to pay the **Contractor** in current funds for the performance of the Contract subject to additions and deductions as provided in the General Conditions of the Contract, and to make payments on account thereof as provided in Section 109 of the Specifications, as modified in the General Conditions and Special Provisions.

The **Contractor** and their subcontractors, material suppliers, vendors and other participates must complete the Lower Tier Contractor Certification Regarding Debarment, Suspension And Other Responsibility Matters form contained herein.

The **Contractor** must complete the DBE Goals List in order to comply with the goal to provide a minimum of 5% DBE participation on this project or complete the explanation sheet.

CONTRACT AGREEMENT

(page 2 of 2)

IN WITNESS WHEREOF, the parties to those presents have executed this Contract in two (2) counterparts, each of which shall be deemed an original.

Executed this ___ day of _____, 20____.

PUTNAM COUNTY, GEORGIA

ATTEST: _____
Ex-Officio Clerk

By: _____ (print)
Stephen J. Hersey
Chairman, Board of Commissioners

(s) _____

CONTRACTOR

ATTEST: By: _____
Secretary or Assistant
(seal)

Name of Firm

By: _____ (print)
President or Vice President

(s) _____

Approved as to Form:

County Attorney

100% PERFORMANCE BOND
page 1 of 2

KNOW ALL MEN BY THESE PRESENTS: that, _____, as Principal, hereinafter called **Contractor**, and _____, a corporation organized and existing under the laws of the State of Georgia, hereinafter called **Surety**, are held and firmly bound unto PUTNAM COUNTY, GEORGIA, as obligee, hereinafter called **County**, in the amount **Dollars And _____ Cents (\$_____)** for the

payment whereof **Contractor** and **Surety** bind themselves, their heirs, executors, administrators, successors and assigns, jointly and severally, firmly by these presents.

WHEREAS, **Contractor** has by written agreement dated _____, 20____, entered into a contract with **County** for:

Furnishing all labor, materials and equipment for the Reids Rd/Ponder Pines Rd Unpaved Road Improvement Project which includes the reconstruction of the unpaved roadway, grading, asphalt resurfacing, drainage, erosion & sedimentation control and other major construction details

in accordance with drawings prepared by Patrick & Associates, Inc. and specifications prepared by Collaborative Infrastructure Services, Inc., which contract is by reference made a part hereof, and is hereinafter referred to as the Contract.

NOW, THEREFORE, the condition of this obligation is such that, if **Contractor** shall promptly and faithfully perform said Contract, then this obligation shall be null and void, otherwise it will remain in full force and effect.

The **Surety** hereby waives notice of any alteration or extension of time made by the **County**.

Whenever **Contractor** shall be, and declared by **County** to be, in default under the Contract, the **County** having performed **County's** obligation thereunder, the **Surety** may promptly remedy the default, or shall promptly:

1. Complete the Contract in accordance with its terms and conditions; or,
2. Obtain a bid or bids for completing the Contract in accordance with its terms and conditions, and upon determination by **Surety** of the lowest bidder, or, if the **County** elects, upon determination by the **County** and **Surety** jointly of the lowest responsible bidder, arrange for a Contract between such Bidder and the **County**, and make available as work progresses (even though there should be a default or a succession of defaults under the Contract or Contract of Completion arranged under this paragraph) sufficient funds to pay the cost of completion less the balance of the Contract price; but not exceeding, including other costs and damages for which the **Surety** may be liable hereunder, the amount set forth in the first paragraph hereof. The term "Balance of the Contract Price", as used in this paragraph shall mean the total amount payable by **County** to **Contractor** under the Contract and any amendments hereto, less the amount properly paid by **County** to **Contractor**.

100% PERFORMANCE BOND
page 2 of 2

No action can be instituted on this bond after one year from the completion of the Contract and the acceptance by the **County** of the work thereunder.

Signed and sealed this ___ day of _____, 20 ____ .

in the presence of:

Contractor

By: _____ (SEAL)

-
Witness: _____

Surety

By: _____ (SEAL)

-
Witness: _____

100% LABOR AND MATERIAL PAYMENT BOND
page 1 of 2

KNOW ALL MEN BY THESE PRESENTS: that, _____, as Principal, hereinafter called **Contractor**, and _____, a corporation organized and existing under the laws of the State of Georgia, hereinafter called **Surety**, are held and firmly bound unto PUTNAM COUNTY, GEORGIA, as obligee, hereinafter called **County**, in the amount of _____

for the payment whereof **Contractor** and **Surety** bind themselves, their heirs, executors, administrators, successors and assigns, jointly and severally, firmly by these presents.

WHEREAS, Contractor as by written agreement dated _____, 20____, entered into a Contract with County for:

Furnishing all labor, materials and equipment for the Reids Rd/Ponder Pines Rd Unpaved Road Improvement Project which includes the reconstruction of the unpaved roadway, grading, asphalt resurfacing, drainage, erosion & sedimentation control and other major construction details

in accordance with drawings prepared by Patrick & Associates, Inc. and specifications prepared by Collaborative Infrastructure Services, Inc., which contract is by reference made a part hereof, and is hereafter referred to as the Contract.

NOW, THEREFORE, the condition of this obligation is such that if the Contractor shall promptly make payment to all claimants as is herein below defined, for all labor and materials used or reasonably required for use in the performance of the Contract, this obligation shall be null and void; otherwise, it shall remain in full force and effect subject, however, to the following conditions:

1. A claimant is defined as one having a direct contract with the Contractor or with a Subcontractor of the Contractor for labor, material, or both, used or reasonably required for use in the performance of the Contract; labor and material being construed to include that part of water, gas, power, light, heating oil, gasoline, telephone service, rental of equipment, or repair of equipment directly applicable to the Contract.
2. The above-named Contractor and Surety hereby jointly and severally agree with the County that every claimant as herein defined, who has not been paid in full before the expiration of a period of ninety (90) days after the date on which the last of such claimant's work or labor was done or performed, or materials were furnished by such claimant, may sue on this bond for the use of such claimant, prosecute the suit to final judgment for such sum or sums as may be justly due claimant, and have execution thereon. The County shall not be liable for the payment of any costs or expenses of any such suit.
3. No suit or action shall be commenced hereunder by any claimant:
 - A. Unless claimant, other than one having a direct contract with the Contractor, shall have given written notice to any two of the following: the Contractor, the County, or the Surety above-

100% LABOR AND MATERIAL PAYMENT BOND
page 2 of 2

named, within ninety (90) days after such claimant did or performed the last of the work or labor, or furnished the last of the materials for which said claim is made, stating with substantial accuracy the amount claimed and the name of the party to whom the materials were furnished, or for whom the work or labor was done or performed. Such notice shall be served by mailing the same by registered mail or certified mail, postage prepaid, in an envelope addressed to the Contractor, the County, or the Surety, at any place where an office is regularly maintained for the transaction of business, or served in any manner in which legal process may be served in the State in which the aforesaid project is located, save that such service need not be made by a public officer.

B. After one year from the completion of the Contract and the acceptance by County of the Work thereunder; it being understood, however, that if any limitation embodied in this bond is prohibited by any law controlling the construction hereof, such limitation shall be deemed to be amended so as to be equal to the minimum period of limitation permitted by such law.

C. Other than in a state court of competent jurisdiction in and for the County or other political subdivision of the State in which the Project, or any part thereof, is situated, or in the United States District Court for the district in which the Project, or any part thereof, is situated and not elsewhere.

4. The amount of this bond shall be reduced by and to the extent of any payment or payments made in good faith hereunder, inclusive of the payment by Surety for mechanics' liens which may be filed on record against improvement, whether or not claim for the amount of such lien be presented under and against this bond.

Signed and sealed this _____ day of _____, 20_____ .

Contractor

By: _____ (Seal)

Witness

Surety

By: _____ (Seal)
Georgia Representative

Witness

This bond is issued simultaneously with Performance Bond in favor of the County.

NON-COLLUSION AFFIDAVIT OF SUBCONTRACTOR

State of _____)

County of _____)

_____, being first duly sworn, deposes, and says that:

1. He is _____ (Owner, Partner, Officer, Representative, or Agent) of _____, hereinafter referred to as the "Subcontractor";
2. He is fully informed respecting the preparation and contents of the Subcontractor's Proposal submitted by the Subcontractor to _____, the Contractor, for certain work in connection with the _____ Contract pertaining to the Project in Putnam County, Georgia;
3. Such Subcontractor's Proposal is genuine and is not a collusive or sham Proposal;
4. Neither the Subcontractor nor any of its officers, partners, owners, agents, representatives, employees, or parties in interest, including this affiant, has in any way colluded, conspired, connived, or agreed, directly or indirectly, with any other Bidder, firm or person to submit a collusive or sham Proposal in connection with such Contract or to refrain from submitting a Proposal in connection with such Contract or has in any manner, directly or indirectly, sought by unlawful agreement or connivance with any other Bidder, firm, or person to fix the price or prices in said Subcontractor's Proposal, or to secure through collusion, conspiracy, connivance, or unlawful agreement any advantage against Putnam County or any person interested in the proposed Contract; and,
5. The price or prices quoted in the Subcontractor's Proposal are fair and proper and are not tainted by any collusion, conspiracy, connivance, or unlawful agreement on the part of the Bidder or any of its agents, representatives, owners, employees, or parties in interest, including this affiant.

(Signed) _____

Name _____ (Print)

Title _____

Subscribed and Sworn to before me

This _____ day of _____, 20 _____.

_____(SEAL)

Title

FINAL AFFIDAVIT

TO: PUTNAM COUNTY, GEORGIA

I, _____, hereby certify that all suppliers of materials, equipment and service, Subcontractors, mechanics, and laborers employed by _____ or any of his Subcontractors in connection with the construction of

Furnishing all labor, materials and equipment for the Reids Rd/Ponder Pines Rd Unpaved Road Improvement Project which includes the reconstruction of the unpaved roadway, grading, asphalt resurfacing, drainage, erosion & sedimentation control and other major construction details

in PUTNAM COUNTY have been paid and satisfied in full as of _____, 20____, and that

there are no outstanding obligations or claims of any kind for the payment of which Putnam County on the above named project might be liable, or subject to, in any lawful proceeding at law or in equity.

Signature : _____

Title : _____

Personally appeared before me this _____ day of _____, 20_____.

_____, who under oath deposes and says that he is of the firm of _____ that he has read the above statement and that to the best of his knowledge and belief same is an exact true statement.

Notary Public _____

My Commission Expires _____

Date _____

NOTICE TO CONTRACTORS**COMPLIANCE WITH TITLE VI OF THE CIVIL RIGHTS ACT OF 1964**

During the performance of this Agreement, the Contractor, for itself, its assignees and successors in interest (hereinafter referred to as the "Contractor"), agrees as follows:

1. Compliance with Regulations: The Contractor will comply with the Regulations of the County of Transportation relative to nondiscrimination in Federally-assisted programs of the County of Transportation (Title 49, Code of Federal Regulations, Part 21, hereinafter referred to as the Regulations [also 49 CFR Part 27]), which are herein incorporated by reference and made a part of this contract.
2. Nondiscrimination: The Contractor, with regard to the work performed by it after award and prior to completion of the contract work, will not discriminate on the grounds of race, color, national origin, or sex in the selection and retention of subcontractors including procurement of materials and leases of equipment. The Contractor will not participate either directly or indirectly in the discrimination prohibited by Section 21.5 of the Regulations, including employment practices when the contract covers a program, set forth in Appendix B of the Regulations. In addition, the Contractor will not participate either directly or indirectly in the discrimination prohibited by 23 CFR 710.405(b).
3. Solicitations for Subcontracts, Including Procurement of Materials and Equipment: In all solicitations, either by competitive bidding or negotiations made by the Contractor for work to be performed under a subcontract, including procurement of materials or equipment, each potential subcontractor or supplier shall be notified by the Contractor of the Contractor's obligations under this contract and the Regulations relative to nondiscrimination on the grounds of race, color, national origin or sex.
4. Information and Reports: The Contractor will provide all information and reports required by the Regulations, or orders and instructions issued pursuant thereto, and will permit access to its books, records, accounts, other sources of information, and its facilities as may be determined by the State County of Transportation or the Federal Highway Administration to be pertinent to ascertain compliance with such Regulations, orders, and instructions. Where any information required of a Contractor is in the exclusive possession of another who fails or refuses to furnish this information, the Contractor shall so certify to the State County of Transportation, or the Federal Highway Administration as appropriate, and shall set forth what efforts it has made to obtain the information.
5. Sanctions for Noncompliance: In the event of the Contractor's noncompliance with the nondiscrimination provisions of the contract, the State County of Transportation shall impose such contract sanctions as it or the Federal Highway Administration may determine to be appropriate, including, but no limited to
 - a. Withholding of payments to the Contractor under the contract until the Contractor complies, and/or
 - b. Cancellation, termination or suspension of the contract, in whole or in part.

6. Incorporation of Provisions: The Contractor will include the provision of paragraphs (1) through (6) in every subcontract, including procurement of materials and leases of equipment, unless exempt by the Regulations, order, or instructions issued pursuant thereto. The Contractor will take such action with respect to any subcontract or procurement as the State County of Transportation of the Federal Highway Administration may direct as a means of enforcing such provisions including sanctions for noncompliance. Provided, however, that in the event a Contractor becomes involved in, or is threatened with, litigation with a subcontractor or supplier as a result of such direction, the Contractor may request the State to enter into such litigation to protect the interests of the State, and, in addition, the Contractor may request the United States to enter into such litigation to protect the interests of the United States.

PRIME CONTRACTORS WORK AUTHORIZATION
CERTIFICATION

PRIME CONTRACTOR’S WORK AUTHORIZATION CERTIFICATION

Pursuant to O.C.G.A. § 13-10-91, all qualifying contractors and sub-contractors performing work within the State of Georgia on a contract with a public employer must register and participate in a federal work authorization program. Prime contractors may participate in any of the electronic verification of work authorization programs operated by the United States Department of Homeland Security or any equivalent federal work authorization program operated by the United States Department of Homeland Security to verify information of newly hired employees, pursuant to the Immigration Reform and Control Act of 1986 (“IRCA”).

The date by which a prime contractor must register and participate in a qualifying federal work authorization program depends on the number of employees in the prime contractor’s company. If the prime contractor’s company has 500 or more employees, it is required to register and participate in a qualifying federal work authorization program by July 1, 2007. If the prime contractor’s company has 100 or more employees, it is required to register for and participate in a qualifying federal work authorization program by July 1, 2008. If the prime contractor’s company has 99 employees or fewer, it is required to register for and participate in a qualifying federal work authorization program by July 1, 2009.

Certify compliance with O.C.G.A. § 13-10-91 by checking the appropriate line below:

_____ The undersigned has registered for and is participating in a qualifying federal work authorization program;

or,

_____ The undersigned is not required to register for or participate in a qualifying federal work authorization program at this time. But, if the undersigned becomes a qualifying prime contractor in the future, the undersigned agrees to register for and participate in a qualifying federal work authorization program.

The undersigned further agrees that, should it employ or contract with any subcontractor(s) in connection with the physical performance of services within this state pursuant to this contract with a public employer, the undersigned will secure from such subcontractor(s) a verification of compliance with O.C.G.A. § 13-10-91 using the form “Subcontractor’s Work Authorization Certification” or a substantially similar form. The undersigned will maintain records of compliance and provide a copy of each sub-contractor’s verification to the public employer at the time the sub-contractor is retained to perform such service.

[SIGNATURE ON NEXT PAGE]

BY: Authorized Officer or Agent

Date

Title of Authorized Officer or Agent

Basic Pilot User Identification Number
(if applicable)

Printed Name of Authorized Officer
or Agent

With express authority on behalf of:

Printed Name of Prime Contractor

SUBSCRIBED AND SWORN
BEFORE ME ON THIS THE
_____ DAY OF _____, 20__.

Notary Public

My Commission Expires: _____

SUBCONTRACTORS NOTIFICATION LIST

Required information on Subcontractors doing work in Putnam County:

Please list any Subcontractors, the address, Business License number, scope of work and start date, and percent of work assigned for each Subcontractor who may be doing work in the County.

General Contractor/Developer: _
License Number: _____

Subcontractor: _
License Number: _ Start Date: _
Scope of Work: _ Percent of Work: _

Subcontractor: _
License Number: _ Start Date: _
Scope of Work: _ Percent of Work: _

Subcontractor: _
License Number: _ Start Date: _
Scope of Work: _ Percent of Work: _

Subcontractor: _
License Number: _ Start Date: _
Scope of Work: _ Percent of Work: _

Subcontractor: _
License Number: _ Start Date: _
Scope of Work: _ Percent of Work: _

**REIDS ROAD/PONDER PINES ROAD UNPAVED ROAD
IMPROVEMENT PROJECT**

BID SCHEDULE OF ITEMS

Contract Scope: Furnishing all labor, materials and equipment for the Reids Rd/Ponder Pines Rd Unpaved Road Improvement Project which includes the reconstruction of the unpaved roadway, grading, asphalt resurfacing, drainage, erosion & sedimentation control and other major construction details

Vendor: _____

Signature: _____

**THE BID SCHEDULE WILL BE DULICATED AS PART OF THE
CONTRACT.**

END OF SECTION

PUTNAM COUNTY, GEORGIA

PROJECT #15-1

**REIDS ROAD/PONDER PINES ROAD
UNPAVED ROAD IMPROVEMENT
PROJECT**

GENERAL CONDITIONS

Putnam County Board of Commissioners

GENERAL CONDITIONS

Unless otherwise directed, all work performed under this contract shall be in accordance with the Georgia County of Transportation Standard Specifications, Construction of Transportation Systems, 2001 Edition, and any Supplemental Specifications modifying them, except as noted below and in the Special Provisions.

Modification of Standard Specifications

SECTION 101 - DEFINITION AND TERMS

Section 101.10 BOARD

Delete as written and substitute the following:

"BOARD OF COMMISSIONERS OF PUTNAM COUNTY, GEORGIA";

Section 101.13 CHIEF CIS. INC

Delete as written and substitute the following:

"THE PUTNAM COUNTY MANAGER" Section 101.14

Delete as written and substitute the following:

"THE CHAIRMAN OF THE BOARD OF COMMISSIONERS OF PUTNAM COUNTY"

Section 101.16 CONTRACT

Delete the second paragraph and substitute the following:

"The Contract Documents shall be composed of the Advertisement for Bid; Notice to **Contractors**; Form of Bid Proposal; General Conditions; Special Provisions; Detail Specifications, as identified in Section 105.04; Form of Contract; Form of Bond(s); Addenda; the drawings, including all changes incorporated herein before their execution; and also any Change Orders and Supplemental Agreements that are required to complete the construction of The Work in an acceptable manner, including authorized extensions thereof, all of which constitute one instrument. No oral agreement or orders are to be considered as valid or as a part of the Contract."

Section 101.22 COUNTY

Delete as written and substitute the following:

"THE PUTNAM COUNTY MANAGER" Section 101.24

CIS. INC

Delete as written and substitute the following:

"THE PUTNAM COUNTY MANAGER, ACTING DIRECTLY OR THROUGH HIS DULY AUTHORIZED REPRESENTATIVES."

Section 101.62 STATE HIGHWAY CIS. INC

Delete as written and substitute the following:

"THE PUTNAM COUNTY MANAGER, ACTING DIRECTLY OR THROUGH HIS DULY AUTHORIZED REPRESENTATIVES."

Section 101.74 SUPPLEMENTAL AGREEMENT

Retain as written and add the following:

"Any Supplemental Agreement that has a dollar value amount that is less than \$25,000.00 shall not require the assent of the Surety."

Section 101.81 TREASURER

Delete as written and substitute the following:

"THE PUTNAM COUNTY DIRECTOR OF FINANCE"

Add Section 101.84:

Section 101.84 "COUNTY: THE PUTNAM COUNTY BOARD OF COMMISSIONERS"

SECTION 102 - BIDDING REQUIREMENTS AND CONDITIONS

Section 102.01 PREQUALIFICATION OF BIDDERS

Delete in its entirety and substitute the following:

"Proposals will be considered only from experienced and well-equipped Contractors engaged in work of this type and magnitude. Contractors must be presently prequalified to do this type of work with the Georgia County of Transportation and have received a Certificate of Qualification in accordance with the Rules and Regulations approved and adopted by the State Transportation Board.

Bidders may be required to submit evidence setting forth qualifications which entitle him to considerations as a responsible Contractor. A list of work of similar character successfully completed within the last two years may be required giving the location, size and listing equipment available for use on this work. Before accepting any bid, the **County** may require evidence of the Contractor's financial ability to successfully perform the work to be accomplished under the contract.

The **County** may make such investigations as it deems necessary to determine the ability of the **Bidder** to perform the work, and the **Bidder** shall furnish to the **County** all such information and data for this purpose as the **County** may request. The **County** reserves the right to reject any bid if the evidence submitted by, or investigation of, such **Bidder** fails to satisfy the **County** that such **Bidder** is properly qualified to carry out the obligations of the Contract and to complete the work contemplated therein. Conditional bids will not be accepted."

Section 102.03 CONTENTS OF PROPOSAL FORMS

Delete in its entirety and add the following:

"Upon request, the **County** will furnish the prospective **Bidder** with a Proposal Form. This form will state the location and description of the contemplated construction and will show the approximate estimate of the various quantities and kinds of work to be performed or materials to be furnished, and will have a Schedule of Items for which Unit Bid prices are invited. The Proposal Form will state the time in which The Work must be completed, the amount of the Proposal Guaranty, and the date of the opening of Proposals. The form will also include any Special Provisions or requirements which vary from or are not contained in the Standard Specifications. All papers which are required to be submitted as part of the Proposal are identified in the Proposal Form, and those papers must not be altered except as directed by Addendum. The Plans, Specifications, and other documents designated in the Proposal Form will be considered a part of the Proposal whether attached or not. The prospective **Bidder** will be required to pay the sum stated in the Notice to Contractors for each copy of the Proposal Form and each set of Plans."

Section 102.05 EXAMINATION OF PLANS, SPECIFICATIONS, SPECIAL PROVISIONS, AND SITE OF THE WORK

Add the following:

"Each **Bidder** must inform himself fully of the conditions relating to the construction of the project and the employment of labor thereon. Failure to do so will not relieve a successful **Bidder** of his obligation to furnish all material and labor necessary to carry out the provisions of his Contract. Insofar as possible the **CONTRACTOR**, in carrying out his work, must employ such methods or means as will not cause any interruption of or interference with the work of any other contractor. Bidders, before making proposals, shall examine the plans and specifications and make such examinations on the ground as are necessary to thoroughly familiarize themselves with the nature and extent of the proposed construction and all local conditions affecting the same, as the **County** will not be responsible for **Bidder's** errors or misjudgment, nor for any information on local conditions or general laws or regulations.

No interpretation of the meaning of the plans and specifications or other pre-bid documents will be made to any bidder orally. Every request for such interpretations should be in writing and addressed to:

Putnam County Board of Commissioners
 Attn.: Paul Van Haute; County Manager
 117 Putnam Drive; Suite A
 Eatonton, GA 31064
 Phone: 770-485-5826
 Email: pyanhaute@putnamcountyga.us

and to be given consideration must be received at least six (6) calendar days prior to the date fixed for the opening of bids. Any and all such interpretations and any supplemental instructions will be in the form of written addenda to the Specifications which, if issued, will be mailed by registered mail, with return receipt requested, to all prospective **Bidders**, at the respective addresses furnished for such purposes, not later than three days prior to the date fixed for the opening of bids. Failure of any bidder to receive any such addendum or interpretation shall not relieve such **Bidder** from any obligation under his bid as submitted. All addenda so issued shall become part of the Contract Documents.

At the time of the opening of bids, each **Bidder** will be presumed to have inspected the site and to have read and to be thoroughly familiar with the plans and Contract Documents (including all addenda). The failure or omission of any **Bidder** to examine any form, instruments or documents shall in no way relieve any bidder from any obligation in respect to his bid."

Section 102.06 PREPARATION OF PROPOSAL

Retain as written except delete the sixth and seventh paragraphs, and add the following:

"If a proposal is made by an individual, his name and post office address must be shown. If made by a firm or partnership, the name and post office address of each member of the firm or partnership must be shown. If made by a corporation, the person or persons signing the proposal must show the name of the state under which the laws of the corporation are chartered and his or their authority for signing same; the names, titles, and address of their President, Secretary, and Treasurer, and the corporate authority for doing business in Georgia."

Section 102.07 REJECTION OF PROPOSALS

Add the following subparagraphs:

I. The **County** reserves the right to reject any and all bids, to waive formalities and to re-advertise. It is understood that all bids are made subject to this Contract Agreement, that the **County** reserves the right to award the bid to the lowest, responsible Bidder, and in arriving at this decision, full consideration will be given to the reputation of the Bidder, his financial responsibility, and work of this type successfully completed.

J. The **County** also reserves the right to reject any and all bids from any person, firm, or corporation who is in arrears in any debt or obligation to Putnam County, Georgia."

Section 102.08 PROPOSAL GUARANTY

Delete and substitute the following:

"No proposal will be considered unless it is accompanied by a certified check or acceptable Bid Bond in an amount not less than five percent (5%) of the amount bid and made payable to the Board of Commissioners of Putnam County. Such Bid Bond shall be on the forms provided by the **County**.

Each bid must be accompanied by a Bid Bond prepared on the form of Bid Bond attached hereto, duly executed by the **Bidder** as **Contractor**, and having as surety thereon a surety company approved by the **County** and accepted by the U. S. County of the Treasury and listed in County Circular 570. The surety must be licensed to conduct business in the State of Georgia. The Bid Bond must be in the amount of 5% of the bid. No Proposal Guaranty will be considered to cover any Bid except the one to which it is attached.

Attorneys-in-fact who sign Bid Bonds must file a certified and effectively dated copy of their power of attorney."

Section 102.09 DELIVERY OF PROPOSALS

Delete in its entirety and substitute the following:

"All bids must be on forms in conformity with the proposal form included herein and must be for labor and materials called for in the Specifications, shown on the plans and bulletins issued prior to bidding. Bids must be submitted in a sealed envelope of sufficient size with the following clearly typed or printed on the outside:

Putnam County County Board of Commissioners
Proposal for Construction
Project Name
Date and Hour of Bid Opening
Company Name

If forwarded by mail, the sealed envelope containing the bid must be enclosed in another envelope addressed as specified in the bid form.

The entire proposal package as designated in the Proposal Form must be submitted with the bid. Failure to do so could result in the omission of pertinent documents and the rejection of the apparent low bid."

Three (3) hard copies will be required for review purposes.

Section 102.10 WITHDRAWAL OR REVISION OF PROPOSALS

Add the following:

"Any **Bidder** may modify his bid by letter or facsimile transmission at any time prior to the scheduled closing time for receipt of bids, provided such communication is received by the **County** prior to the closing time and provided, further, the **County** is satisfied that a written confirmation of the transmitted modification over the signature of the bidder was mailed prior to the closing time. If written confirmation is not received within two days from the closing time, no consideration will be given to the transmitted modification."

SECTION 103 - AWARD AND EXECUTION OF CONTRACT

Section 103.01 CONSIDERATION OF PROPOSALS

Delete the third sentence in its entirety and substitute the following:

"In determining Unit Bid Prices, fractional parts of a cent less than one cent (\$0.01) will not be considered significant and will be dropped."

Section 103.02 AWARD OF CONTRACT

Delete in its entirety and substitute the following:

If prior to the award of a Contract, the **County** determines that because of errors in the bidding documents an unbalanced bid has been submitted and that such unbalanced bid is the lowest bid of the reliable bids received, the **County**, prior to its decision on the award of the Contract, may negotiate with the lowest reliable bidder to correct such errors and to correct the unbalanced bid provided that the lowest reliable bidder is not changed. Subject to the negotiations, the **County** may award the Contract or reject the Contract and re-advertise, abandon the project or perform the work itself.

If a Contract is awarded, it will be awarded to the lowest responsible **Bidder**. The **County** will determine that **Bidder**, and, in so doing, the following elements will be considered: (a) maintains permanent place of business; (b) has adequate plant equipment to do the work properly and expeditiously; (c) has a suitable financial status to meet obligations incident to the work; and (d) has appropriate technical experience (e) past performance on county contracts (ie: scheduling, coordination, cooperation, etc.) (f) past, pending, or threatened litigation, arbitration, or mediation with the County. The Contract will be awarded on the base bid only. Putnam County reserves the right to exercise its discretion as to the responsibility of any **Bidder**.

When notified by and of the County Manager's recommendation for award of this Contract, the **Contractor** shall immediately secure Performance and Payment Bonds as per the Contract, properly execute two (2) original Contract Documents and submit them to the **County**, with proof of insurance in accordance with the Special Provision in the Proposal, within five (5) calendar days of notification.

The Board shall have the right to hold bids after bid opening for a period of sixty (60) days and Contractor shall guarantee all unit prices during this period.

Section 103.04 RETURN OF PROPOSAL GUARANTY

Delete in its entirety and add the following:

"All Proposal Guaranties (Bid Bonds) will be returned to all except the three lowest **Bidders** within ten (1 0) days after the opening of the bids, and the remaining Bid Bonds will be returned promptly after the **County** and the accepted **Bidder** have executed the Contract, or, if no award has been made within 60 calendar days after the date of the opening of bids, upon demand of the **Bidder** at any time thereafter, so long as he has not been notified of the acceptance of this bid.

The **County** reserves the right to return all Proposal Guaranties by registered or certified mail and its responsibility pertaining to them will end when they are mailed."

Section 103.05 REQUIREMENTS OF PERFORMANCE AND PAYMENT BONDS

Delete in its entirety and substitute the following:

"Simultaneously with his delivery of the executed Contract, the **Contractor** shall furnish a surety bond or bonds, in a sum equal to the full amount of the Contract, as security for faithful performance of the Contract and for the payment of all persons performing labor on the project under this Contract, and furnishing material in connection with this Contract. The surety on such bond or bonds shall be a duly authorized surety company satisfactory to the **County** and be countersigned by the State of Georgia's representative/agent. The surety issuing the bonds must be accepted by the U.S. County of the Treasury and listed in County Circular 570 and approved by the **County**.

Attorneys-in-fact who sign performance and payment bonds must file a certified and effectively dated copy of their power of attorney."

Section 103.06 EXECUTION AND APPROVAL OF CONTRACT

Delete in its entirety and substitute the following:

"The Contract shall be signed by the successful bidder and returned within 7 calendar days after the date of the letter transmitting the Contract to the Bidder. If the Contract is not executed by County within 60 calendar days following receipt from the Bidder of the Signed Contract, unless a longer period is specified in the Proposal or the successful Bidder agrees in writing to a longer period, the Bidder shall have the right to withdraw his Bid without penalty. No Contract shall be considered as effective until it has been fully executed by all of the parties.

Execution of the Contract by **Contractor** shall not be considered complete unless **Contractor** submits proper proof of coverage of Insurance in compliance with the following requirements:

- A. **Contractor's** Liability Insurance: **Contractor** shall purchase and maintain such comprehensive general liability and other insurance as will provide protection from claims set forth below which may arise out of or result from **Contractor's** performance or non-performance of the work and **Contractor's** other obligations under the Contract Documents, whether such performance is by the **Contractor's** own organization, its subcontractors or suppliers, or any individual directly or indirectly employed by any of them, or by anyone for whose acts any of them may be liable.

The Contractor, at all times that this Contract is in force, agrees to provide, as a minimum, insurance coverages in accordance with the attached insurance requirements. The **County**, its subcontractors, and affiliated companies, their officers, directors, and employees shall be named on the Certificates of Insurance as additional insured and endorsed onto the policies for Comprehensive General Liability, Automobile Liability and Umbrella Liability Insurance maintained pursuant to this Contract in connection with liability

of the **County** and their officers, directors and employees arising out of Contractor's operations. Copies of the endorsements shall be furnished to the **County** prior to execution of the contract. Such insurance is primary insurance and shall contain a severability of interest clause as respects each insured.

- 1) Claims under workers' or workmen's compensation, disability benefits and other similar employees benefit acts;
- 2) Claims for damages because of bodily injury, occupational sickness or disease, or death of **Contractor's** employees;
- 3) Claims for damages because of bodily injury, sickness or disease, or death of any person other than **Contractor's** employees;
- 4) Claims for damages insured by personnel injury liability coverage which are sustained a) by any person as a result of an offense directly or indirectly related to the employment of such person by **Contractor**, or b) by any other person for any other reason;
- 5) Claims for damages, other than to work itself because of injury to or destruction of tangible property, including loss of use resulting therefrom; and,
- 6) Claims for damages because of bodily injury or death of any person or property damage arising out of the ownership, maintenance, or use of any motor vehicle.

The insurance required by this paragraph shall include the specific coverages and be written for not less than the limits of liability and coverages provided in these specifications, or required by law, whichever is greater. The comprehensive general liability insurance shall include completed operations insurance. All such insurance shall contain a provision that the coverage afforded will not be canceled, materially changed, or renewal refused until at least thirty (30) days prior written notice has been given to **County**. All such insurance shall remain in effect until final payment and at all times thereafter when **Contractor** may be correcting, removing, or replacing defective work. In addition, **Contractor** shall maintain such completed operations insurance for at least one year after final payment and furnish **County** with evidence of continuation of such insurance at final payment.

- B. **County** shall not be responsible for purchasing and maintaining any property insurance to protect the interests of **Contractor** or subcontractors in the work to the extent of any deductible amounts that are provided in the supplemental conditions. If **Contractor** wishes property insurance coverage within the limits of such amounts **Contractor** may purchase and maintain it at his own expense.
- C. If **County** has any objection to the coverage afforded by or other provisions of the insurance required to be purchased and maintained by **Contractor** in accordance with subparagraphs A through E, **County** will notify **Contractor** thereof within ten (10) days of the date of the delivery of such certificates to **County**. **Contractor** will provide to the **County** such additional information in respect of insurance provided by him as **County** may reasonably request. The right of the **County** to review and comment on Certificates of Insurance is not intended to relieve the **Contractor** of his responsibility to provide insurance coverage as specified nor to relieve the **Contractor** of his liability for any claims which might arise.
- D. The limits of liability for the insurance required by paragraph A of these General Conditions shall provide coverage for not less than the following amounts or greater where required by law.

For Claims under paragraphs A.1 and A.2, Workmen's Compensation

| | |
|--|--------------------|
| State | Statutory |
| Applicable Federal (e.g.) Longshoremen's | Statutory |
| Employer's Liability | \$1,000,000/person |

\$1,000,000/occurrence

For Claims under A.2 through A.5,

Bodily Injury:

| | |
|-------------|--|
| \$1,000,000 | Each Person |
| \$1,000,000 | Each Occurrence |
| \$1,000,000 | Annual Aggregate Products and Completed Operations |

Property Damage:

| | |
|-------------|-----------------|
| \$1,000,000 | Each Person |
| \$1,000,000 | Each Occurrence |

Property Damage Liability Insurance will provide explosion, collapse, and underground coverage where applicable.

Personal injury with employment exclusion deleted.

| | |
|-------------|------------------|
| \$1,000,000 | Annual Aggregate |
|-------------|------------------|

For Claims under A.6, Comprehensive Automobile Liability:

Bodily Injury:

| | |
|-------------|---------------|
| \$1,000,000 | Each Person |
| \$1,000,000 | Each Accident |

Property Damage:

| | |
|-------------|-----------------|
| \$1,000,000 | Each Occurrence |
|-------------|-----------------|

The Contractual Liability required by paragraph B shall provide coverage for not less than the following amounts:

Contractual Liability Insurance:

Bodily Injury:

| | |
|-------------|-----------------|
| \$1,000,000 | Each Occurrence |
|-------------|-----------------|

Property Damage:

| | |
|-------------|------------------|
| \$1,000,000 | Each Occurrence |
| \$1,000,000 | Annual Aggregate |

E. Scope of Insurance and Special Hazards

The amounts of insurance in subparagraph "D" above are minimum amounts of insurance to be carried. The **Contractor** shall carry such additional insurance as may be required to provide adequate protection of the **Contractor** and his subcontractors, respectively, against any and all damage claims which may arise from operations under this Contract, whether such operations may be by the insured or by anyone directly

or indirectly employed by him and, also, against any of the special hazards which may be encountered in the performance of this Contract.

The **Contractor's** and subcontractors' Public Liability and Property Damage Insurance shall provide adequate protection against the following special hazards: excavation, shoring, underpinning, blasting and explosion to the extent to which such risks are present."

Section 103.07 FAILURE TO EXECUTE CONTRACT

Delete in its entirety and substitute the following:

"Failure or refusal to execute and deliver the Contract, Contract Performance and Payment Bond, or furnish satisfactory proof of insurance coverage required within ten (10) days after the date of notice of the County's recommendation for award shall be just cause for the annulment of the award and for the forfeiture of the Proposal Guaranty to Putnam County, not as a penalty, but as liquidation of damages sustained for such failure or refusal. At the discretion of the **County**, the award may then be made to the next lowest responsible Bidder, or the Work may be re-advertised or constructed by County forces.

If the **County** re-advertises the project, the **County** may, at its discretion, not allow the Bidder who refused or failed to execute a contract, or who requested to withdraw any bid, to perform work on that contract or project as a contractor, subcontractor or in any other capacity for any function of construction. The Contract and Contract bonds shall be executed in two (2) original counterparts."

SECTION 105 - CONTROL OF WORK

Section 105.02 PLANS AND WORKING DRAWINGS

Add the following paragraphs:

"If, in the process of the Contract, discrepancies arise, the **Contractor** will be furnished additional instructions and detail drawings as necessary to carry out the work included in the Contract. The additional drawings and instructions thus supplied to the **Contractor** will coordinate with the Contract Documents and will be so prepared that they can be reasonably interpreted as part thereof.

The **Contractor** shall submit promptly to CIS, Inc. three (3) copies of each shop or setting drawing prepared in accordance with the schedule predetermined as aforesaid. After examination of such drawings by CIS Inc and the return thereof, the **Contractor** shall make such corrections to the drawings as have been indicated and shall furnish CIS Inc with two (2) corrected copies. If requested by CIS Inc, the **Contractor** must furnish additional copies. Regardless of corrections made in or approval given to such drawings by CIS Inc, the **Contractor** shall nevertheless be responsible for the accuracy of such drawings and for their conformity to the Plans and Specifications at the time he furnishes such drawings."

Delete Sub-Section 105.07 and substitute the following

105.07 Cooperation Between Contractors

The County reserves the right at any time to Contract for and perform other or additional work on or near The Work covered by the Contract.

When separate Contracts. Regardless of whether it's a County let project (i.e. utility contractors) are let within the limits of any one Project, each Contractor shall conduct his work so as not to interfere with or hinder progress or completion of The Work being performed by other Contractors. Contractors working on the same project shall cooperate with each other.

Each Contractor involved shall assume all liability, financial or otherwise, in connection with his Contract and shall protect and save harmless the County from any and all damages or claims

that may arise because of inconvenience, delay or loss experienced by him because of the presence and operations of other Contractors working within the limits of the same Project.

The Contractor shall arrange his work and shall place and dispose of the materials being used so as to not interfere with the operations of the other Contractors within the limits of the same Project. He shall join his work with that of the others in an acceptable manner and shall perform it in proper sequence to that of the others.

Section 105.14 MAINTENANCE DURING CONSTRUCTION

Retain in its entirety, but insert the following after the first paragraph:

"At all times, the **Contractor** shall perform work as may be required to protect the entire site, including both existing conditions and performed work, from damage. Furthermore, the **Contractor** shall be responsible for all damages to all persons and property due to the non-maintenance of the project site."

SECTION 106 - CONTROL OF MATERIALS

Section 106.03.A.3 SAMPLES, TESTS, CITED SPECIFICATIONS

Add the following paragraphs:

"The costs of any initial tests shall be borne by the **County**. Retesting due to failure of the initial test shall be billed to the **Contractor** by the County to include a ten percent (10%) administrative fee."

"Whenever a material, article, or piece of equipment is identified on the Plans or in the Specifications by reference to manufacturer's or vendor's names, catalog number, etc., it is intended merely to establish a standard; and any material, article, or equipment of the other manufacturers and vendors which will perform adequately the duties imposed by the general design will be considered equally acceptable provided the material, article, or equipment so proposed is, in the opinion of CIS Inc, of equal substance and function. It shall not be purchased or installed by the **Contractor** without CIS Inc's written approval."

SECTION 107 - LEGAL REGULATIONS AND RESPONSIBILITY TO THE PUBLIC

Section 107.02 PERMITS AND LICENSES

Add the following paragraphs:

"The **Contractor** shall provide the **County**, on the proper form, proof of being licensed to do business within Putnam County; proof of proper business licenses shall also be provided by the prime **Contractor** for any and all subcontractors coming under the jurisdiction of this Contract. (See Subcontractors' Notification List.)

Before any work proceeds along areas adjacent to the State Highway, the **Contractor** shall assure that a permit showing that the project is approved by the Georgia County of Transportation is posted. The **Contractor** shall notify CIS Inc. 72 hours before moving into a new area to begin construction."

Section 107.07 PUBLIC CONVENIENCE AND SAFETY

Retain as written and add the following:

"The **Contractor** shall distribute a notice to each residence or business adjacent to the roadway **within the limits** of the project. Notice letter shall also be sent to the Morgan County Board of Commissioners. The **Contractor** shall prepare this notice and obtain approval from **CIS, Inc.** of this letter before the **Contractor** delivers the notices. To ensure that that these notices will be timely, they shall be

distributed at least 72 hours prior to beginning construction activities.

The notices will be used to inform the affected parties of the activities that will be occurring and will identify the **Contractor** (name and 24 phone number of superintendent, and short description of project).

The notice will be in the form of a letter and are not to be placed in or on the mailboxes. The **Contractor** will notify **CIS, Inc.** upon completion of the deliveries. The **Contractor** may not work on the road without the letters being distributed.

Section 107.13 PROTECTION AND RESTORATION OF PROPERTY AND LANDSCAPE

Retain subparagraph C. and add the following paragraph:

"All chemicals used during project construction or furnished for project operation, whether herbicide, pesticide, disinfectant, polymer, reactant, or of other classification, must show approval of either EPA or USDA. Use of all such chemicals and disposal of residues shall be in strict conformance with instructions."

Delete subparagraph F in its entirety and substitute the following:

"The **Contractor** shall have the responsibility for removing and relocating all mailboxes to an area outside of the construction limits but still accessible for mail deliveries and convenient to the mail carrier and the patron during the entire time of construction. It may be necessary for the **Contractor** to confer with the Post Office serving the area.

As soon as construction has progressed to the stage that the mailbox may be erected in its permanent position, the **Contractor** shall coordinate the erection with the patron and the Post Office serving the area. Any damages to the posts or mailboxes due to the removal and/or relocations by the **Contractor** will remain the responsibility of the **Contractor**, all damaged posts and/or mailboxes shall be replaced and installed by the **Contractor** at his expense, including mailbox enclosures of masonry construction.

Any cost or costs to the **Contractor** for removing, relocating or installations of mailboxes as stated above shall be included in the overall bid price. Masonry mail boxes will not be relocated; however, if removed, a standard mail box will be installed."

Section 107.15 RESPONSIBILITY FOR DAMAGE CLAIMS

Add the following paragraph:

"**Contractor** shall indemnify and hold harmless the **County** and its agents, employees, successors, and assigns from and against all loss, cost, damage, claim, suit, and judgment, including attorney's fees, arising out of or resulting from the performance or non-performance of the work. **Contractor's** duty to indemnify applies in connection with, but is not limited to, injury to or death of any person or persons, loss of or damage to property caused by or in any way connected with **Contractor's** performance or non-performance of the work, whether such injury, death, loss, or damage results from any cause whatsoever. The **Contractor's** duty to indemnify shall extend to all claims, damage, loss, or expense caused in whole or in part by any act or omission of the **Contractor**, any subcontractor, or anyone directly or indirectly employed by any of them or anyone for whose acts any of them may be liable, regardless of whether or not it is caused in part by a party indemnified hereunder. The duty of the **Contractor** to indemnify, contained herein, shall not extend to any claim, damage, loss, or expense which results solely from the negligence of a party indemnified hereunder."

Section 107.17 CONTRACTOR'S RESPONSIBILITY FOR THE WORK

Retain in its entirety and add the following new paragraph:

"In case of an emergency which threatens loss or injury of property and/or safety of life, the **Contractor** will be allowed to act, without previous instruction from CIS Inc, in a diligent manner. He shall notify CIS Inc immediately thereafter. Any claim for compensation by the **Contractor** due to such extra work shall be promptly submitted to CIS Inc. for review and then CIS, Inc. will submit to the County for approval or denial of the claim Where the **Contractor** has not taken action but has notified CIS Inc of an emergency threatening injury to persons or damage to the work or any adjoining property, he shall act as instructed or authorized by CIS. Inc."

Section 107.18 AQUISITION OF RIGHT OF WAY

Delete in its entirety and substitute the following:

"The **County** shall furnish all land and right-of-way necessary for the carrying out of this Contract and the completion of the Work herein contemplated and will use due diligence in acquiring said land and rights-of-way as speedily as possible. But it is possible that all lands and rights-of-way as herein contemplated may not be completely secured before construction begins, in which event the **Contractor** shall begin his Work upon such land and rights-of-way as the **County** may have previously acquired, and no claim for damages whatsoever will be allowed by reason of the delay in obtaining the remaining land and rights-of-way. Should the **County** be prevented or enjoined from proceeding with the Work, or from authorizing its prosecution, either before or after the commencement, by reason of any litigation, or by reason of its inability to procure any lands or rights-of-way for the said Work, the **Contractor** shall not be entitled to make or assert claim for damage by reason of said delay, or, to withdraw from the Contract except by consent of the **County**, but time for completion of the Work will be extended to such time as the **County** determines will compensate for the time lost by such delay, such determination to be set forth in writing."

Section 107.20 NO WAIVER OF LEGAL RIGHTS

Retain in its entirety and add the following:

"The **Contractor** shall guarantee the work accomplished under this Contract for a period of twenty-four (24) months from the date of final acceptance. The **Contractor** shall remedy, at his own expense, and without additional cost to the **County**, all defects arising from either workmanship or materials, as determined by CIS Inc. The guarantee shall not cover any accidental or deliberate damage to the work, or any defects occurring due to normal wear and tear during the twenty-four (24) months.

All equipment of whatever nature incorporated in the work covered by this Contract shall carry the same guarantee as outlined above for construction. Failure of any equipment or part thereof within the specified time shall be corrected to the satisfaction of the **County**, at the **Contractor's** expense. This guarantee does not apply to manufacturing defects of equipment furnished by the **County**.

The Performance Bond shall remain in full force and effect through the guarantee period.

107.23 ENVIRONMENTAL CONSIDERATIONS

Delete Subsection 107.23.A and replace with the following:

All environmental considerations and clearances shall be the responsibility of the County or municipality to meet, including the requirements of Section 404 of the Clean Water Act (33 USC 1344).

After July 1, 1991, State funded projects must comply with the requirements of Chapter 16 of Title 12 of the Official Code of Georgia Annotated, the Georgia Environmental Policy Act (GEPA), of 1991. In the compliance with

GEPA, those projects for which Federal funding sought, and NEPA compliance is accomplished, are exempt from the requirements of GEPA.

GEPA requires that environmental documentation be accomplished for local government projects if more than 50 percent of the total project cost is funded by a grant of a State Agency or a grant of more than \$250,000.00 is made by the State Agency to the municipality or County. The “responsible official of the government agency shall determine if a proposed governmental action is a proposed governmental action which may significantly adversely affect the quality of the environment.”

A. The Following Project Would Not Significantly Adversely Affect The Quality Of The Environment:

Non-land disturbing activities and minor land disturbing activities that would not be anticipated to significantly affect the quality of the environment include the following list. These types of projects funded with state money would not be able to subject to environmental assessment of any kind. Hearing procedures outline in GEPA would not be applicable.

1. Minor roadway and non-historic bridge projects.
 - a. Modernization of an existing highway by resurfacing, restoration, rehabilitation, adding shoulders, widening a single lane or less in each direction and the addition of a median within previously disturbed existing right-of-way.
 - b. Adding auxiliary lanes for localized purposes (weaving, climbing, speed changes, etc.) and correction substandard curves and intersections within previously disturbed existing right-of-way.
 - c. Non-historic bridge replacement projects in existing alignment with no detour bridge.
2. Lighting, signing, pavement marking, signalization, freeway surveillance and control systems, and railroad protective devices.
3. Safety projects such as grooving, glazed screen, safety barriers, energy attenuators, median barriers, etc.
4. Highway landscaping and landscaping modification, rest area projects and truck weigh stations within previously disturbed existing right-of-way.
5. Construction of bus shelters and bays within existing right-of-way.
6. Temporary replacement of a highway facility that is commenced immediately after the occurrence of a natural disaster of catastrophic failure to restore the highway for the health, welfare, and safety of the public.

B. The Following Projects May Not Significantly Adversely Affect The Quality of The Environment:

For projects that will cause land disturbance and for which there is no anticipation that the project may significantly adversely affect the quality of the environment, certain studies will be undertaken. These studies would serve to document whether or not the County or municipality should anticipate that a project might significantly adversely affect the quality of the environment. Documentation of the studies will be accomplished through the use of the “GEPA Investigation Studies” checklist.

The types of projects that would fall under the category would include:

1. Bridge replacement projects on new location or with a detour bridge, where there are no significant adverse impacts to historic or archaeological resources, no involvement with Federally listed threatened and endangered species and no significant adverse impact to wetlands.
2. Passing lanes, median additions and widening projects, where there are no significant adverse impacts to historic or archaeological resources, no involvement with Federally listed threatened and endangered species and no significant adverse impact to wetlands.

3. Safety and intersection improvements where there are no significant adverse impacts to historic or archaeological resources, no involvement with Federally listed threatened and endangered species and no significant adverse impact to wetlands.
4. Rest area projects and truck weigh stations with no purchase of additional right-of-way.
5. New location projects where there are no significant adverse impacts to historic or archaeological resources, no involvement with Federally listed threatened and endangered species and no significant adverse impact to wetlands.

If studies demonstrate that the project will not significantly adversely affect the quality of the environment, project files will be documented. If studies demonstrate that the project may significantly adversely affect the quality of the environment, development of an environmental effects report (EER) will be undertaken along with full GEPA compliance.

C. The Following Projects May Not Significantly Adversely Affect The Quality of The Environment:

This category of projects may include major widening and new location projects. If such projects result in a significant adverse effect, an EER shall be prepared.

D. EER Procedure:

GEPA calls for consideration of the “cumulative effect of the proposed government actions on the environment...if a series of proposed government actions are related to either geographically or as logical parts in a chain of contemplated actions.” Therefore, EER’s for sections of roadways to be widened or built as new location facilities will include all projects that are connected geographically or as logical parts in a chain of contemplated actions.

1. During preparation of an environmental effect report, the County or Municipality will consult with and solicit comments from agencies that have jurisdiction by law, special expertise, or other interest with respect to environmental impacts.
2. In compliance with GEPA the following shall be contained in the EER, at a minimum:
 - a. Cover sheet;
 - b. Executive summary;
 - c. Alternatives, including the no-build;
 - d. Relevant environmental setting; Geology, soils, water supply and wetlands, floral fauna, archaeology/history, economic environment, energy, cultural resources;
 - e. The environmental impact of the proposed action of the relevant setting and mitigation measures proposed to avoid or minimize adverse impact;
 - f. Unavoidable adverse environmental effects;
 - g. Value of short-term uses of the environment and maintenance and enhancement of its long-term value;
 - h. Beneficial aspects, both long term and short tem and its economic advantages and disadvantages;
 - i. Comments of agencies which have jurisdiction by law, special expertise, or other interest with respect to any environmental impact or resource;

3. At least 45 days prior to making a decision as to whether to proceed with the undertaking, publish in the "legal organ of each County in which the proposed governmental action or any part thereof is to occur, notice that an environmental effects report has been prepared".
4. The County or Municipality shall send a copy of the EER and all other comments to the Director, EPD.
5. The County or Municipality shall make the document available to the public and agencies, upon request.
6. A public hearing will be held in each affected county if at least 100 residents of the State of Georgia request on within 30 days of publication in the legal organ of an affected County. The responsible official or his designee may hold a public hearing if less than 100 requests are received. (The county or municipality is not relieved of other State legal requirements of public hearings, however.)
7. Following the public notice period and/or public hearing, a summary of the document, comments received and recommendation as to whether to proceed with the action as originally prepared, to proceed with changes, or not to proceed will be prepared (Notice of Decision).
8. This decision document, when signed by the responsible official, will be sent to the director, EPD, and an abbreviated notice of the decision will be published in the legal organ of each County in which the proposed governmental action or any part thereof is to occur.
9. A copy of the decision document, the EER and public hearing comments (if any) will be sent to Putnam County County of Transportation, Georgia County of Transportation, Office of Environment and Location and the County of Natural Resources, Environmental Protection Division for their files.

**County of Transportation Office of
Environment and Location 3933
Aviation Circle
Atlanta, Georgia 30336**

**County of Natural Resources
Environmental Protection Division
205 Butler Street, SE
Suite 1152
Atlanta, Georgia 30334**

SECTION 108 - PROSECUTION AND PROGRESS

Section 108.01 SUBLETTING OF CONTRACT

Retain as written except as follows:

Delete the second and third paragraph and substitute the following:

In case such consent is given, the Contractor will be permitted to sublet a portion thereof, but shall perform, with his own organization, work amounting to not less than sixty percent (60%) of the total contract cost, including materials, equipment and labor.

All Subcontractors approved by CIS. Inc. must submit a "Noncollusion Affidavit for Subcontractors, before any work by that Subcontractor may proceed."

Add the following:

"In accordance with the provisions stated above, the following items are designated Specialty Items whenever they appear in the Contract:

- All Grassing Items
- All Fencing Items
- All Highway Lighting Items
- All Highway Sign Items
- All Guardrail Items (Except Bridge Handrail)
- All Utility Items
- All Comfort and Convenience Facilities in Rest Areas
- All Landscaping Items
- All Pressure Grouting, Slab Removal and Replacement
- All Permanent Traffic Markings
- All Signal Systems
- All Railroad Trackwork above Sub-ballast
- Construction Layout

The cost of the above items will be subtracted from the original Contract Amount and the subsequent balance used to determine the percent limitation mentioned above.

If the **Contractor** elects to sublet a Specialty Item, no work on any such Specialty Items shall be begun without prior approval of the necessary Subcontract.

The **Contractor's** cost for Construction Layout shall be fully documented prior to deduction from the original Contract amount.

108.03 PROSECUTION AND PROGRESS

Retain Subsection 108.03 except as modified below:

For this Project, the Progress Schedule required by Subsection 108.03 need not be submitted.

108.08 FAILURE OR DELAY IN COMPLETING WORK ON TIME

Retain Sub-Section 108.08 as written:

SECTION 109 - MEASUREMENT AND PAYMENT

Section 109.07 PARTIAL PAYMENTS

Delete Subsection 109.07.A in its entirety and substitute the following:

"A. General:

The Contractor shall on the first Business Day of each calendar month submit the estimated total value of items complete in place for the previous calendar month to CIS Inc for verification. If discrepancies are discovered by CIS Inc., a representative from CIS will contact the Contractor to make any necessary corrections as soon as possible. Such estimate is approximate only, and may not necessarily be based on detailed measurements. Value will be computed on the basis of Contract Unit Prices or on percentage of completion of any Lump Sum Item."

Add Subsection 109.07.I to read as follows:

"I. Retainage

5% Retainage will be withheld from payments under this Contract."

Section 109.08 FINAL PAYMENT

Delete in its entirety and substitute the following:

"Upon completion by the **Contractor** of The Work, including the receipt of any final written submission of the **Contractor** and the approval thereof by the CIS, Inc, the **County** will pay the **Contractor** a sum equal to 100 percent (100%) of the compensation set forth herein, less the total of all previous partial payments, paid or in the process of payment.

The **Contractor** agrees that acceptance of this final payment shall be in full and final settlement of all claims arising against the **County** for work done, materials furnished, costs incurred, or otherwise arising out of this Contract Agreement and shall release the **County** from any and all further claims of whatever nature, whether known or unknown for and on account of said Contract Agreement, and for any and all work done, and labor and materials furnished, in connection with same.

No final payment shall be made until the **Contractor AND his Subcontractors** furnish to the **County** a sworn affidavit to the effect that all bills are paid and no outstanding claims, suits and/or liens are pending in connection with the work done or labor and materials furnished under this Contract. Final payment will be made within sixty (60) days after approval by CIS Inc.

The **Contractor** will be required to maintain all work done in a first-class condition for sixty (60) days after the same has been completed as a whole, and CIS, Inc. has notified the **Contractor** in writing that the work has been finished to his satisfaction. The retained percentage will not be due or payable to the **Contractor** until the 60-day maintenance period has ended." The maintenance period is not the same as the two (2) year warranty period.

SECTION 149 - CONSTRUCTION LAYOUT

Section 149.3.05 CONSTRUCTION

Retain Subsection 149.3.05.I and add the following:

3. Denote the offset distance to the construction centerline on the station number stakes, when the station number is maintained in a location other than on the construction centerline.

Delete Subsection K, paragraph 2, which begins, "For new bridges ..." in its entirety.

SECTION 150 - TRAFFIC CONTROL

Add the following:

150.1 General

This section as supplemented by the Plans, Specifications, and Manual on Uniform Traffic Control Devices (MUTCD) shall be considered the Traffic Control Plan. Activities shall consist of furnishing, installing, maintaining, and removing necessary traffic signs, barricades, lights, signals, cones, pavement markings and other traffic control devices and shall include flagging and other means for guidance and protection of and vehicular pedestrian traffic through the Work Zone. This Work shall include both maintaining existing devices and installing additional devices as necessary in construction work zones.

When any provisions of this Specification or the Plans do not meet the minimum requirements of the MUTCD, the MUTCD shall control. The 2009 Edition of the MUTCD shall be in effect for the duration of the project.

The Worksite Traffic Control Supervisor (WTCS) shall have a copy of Part VI of the MUTCD on the job site. Copies of the current MUTCD may be obtained from the FHWA web page at <http://mutcd.fhwa.dot.gov>.

A. WORKER SAFETY APPAREL

All workers exposed to the risks of moving roadway traffic or construction equipment shall wear high-visibility safety apparel meeting the requirements of International Safety Equipment Association (ISEA) American National Standard for High-Visibility Safety Apparel, or equivalent revisions, and labeled as ANSI-2004 Class 2 or 3 risk exposure.

B. Worksite Traffic Control Supervisor

ALL HIGHWAYS (ADDITIONAL REQUIREMENTS BELOW FOR INTERSTATES): The Contractor shall designate a qualified individual as the Worksite Traffic Control Supervisor (WTCS) who shall be responsible for selecting, installing and maintaining all traffic control devices in accordance with the Plans, Specifications, Special Provisions and the MUTCD. A written resume documenting the experience and credentials of the WTCS shall be submitted and accepted by CIS Inc prior to beginning any work that involves traffic control. The WTCS shall be available on a twenty-four (24) hour basis to perform his duties. If the work requires traffic control activities to be performed during the daylight and nighttime hours it may be necessary for the Contractor to designate an alternate WTCS. An alternate WTCS must meet the same requirements and qualifications as the primary WTCS and be accepted by CIS. Inc. prior to beginning any traffic control duties. The Worksite Traffic Control Supervisor's traffic control responsibilities shall have priority over all other assigned duties.

As the representative of the Contractor, the WTCS shall have full authority to act on behalf of the Contractor in administering the Traffic Control Plan. The WTCS shall have appropriate training in safe traffic control practices in accordance with Part VI of the MUTCD. In addition to the WTCS all other individuals making decisions regarding traffic control shall meet the training requirements of the Part VI of the MUTCD.

The WTCS shall supervise the initial installation of traffic control devices. CIS. Inc., prior to the beginning of construction, will review the initial installation. Modifications to traffic control devices as required by sequence of operations or staged construction shall be reviewed by the WTCS.

The WTCS shall be available on a full-time basis to maintain traffic control devices with access to all personnel, materials, and equipment necessary to respond effectively to an emergency situation within forty-five (45) minutes of notification of the emergency.

The WTCS shall regularly perform inspections to ensure that traffic control is maintained. Unless modified by the special conditions or by CIS. Inc., routine deficiencies shall be corrected within a twenty-four (24) hour period. Failure to comply with these provisions shall be grounds for dismissal from the duties of WTCS and/or removal of the WTCS from the project. Failure of the WTCS to execute his duties shall be considered as non-performance under Subsection 150.08.

CIS. Inc., will periodically review the work for compliance with the requirements of the traffic control plan.

On projects where traffic control duties will not require full time supervision, CIS. Inc. may allow the Contractor's Project Superintendent to serve as the WTCS as long as satisfactory results are obtained.

CERTIFIED WORKSITE TRAFFIC CONTROL SUPERVISOR

ADDITIONAL REQUIREMENTS FOR INTERSTATE AND LIMITED ACCESS HIGHWAYS: In addition to the requirements above, the WTCS shall have a minimum of one year's experience directly related to work site traffic control in a supervisory or responsible capacity. The WTCS shall be currently certified by the American Traffic Safety Services Association (ATSSA) Work Site Traffic Supervisor Certification program, the National Safety Council Certification program or an equal approved by the County.

Any work performed on the interstate or limited access highway right-of-way that requires traffic control shall be supervised by the Certified Worksite Traffic Control Supervisor. No work requiring traffic control shall be performed unless the certified WTCS is on the worksite. Failure to maintain a Certified Worksite Traffic Control Supervisor on the work will be considered as non-performance under Subsection 150.08.

The WTCS shall perform, as a minimum, weekly traffic control inspections on all interstate and limited access highways. The inspection shall be reported to CIS. Inc on a TC-1 report. CIS. Inc will furnish a blank copy of the TC-1 report to the Contractor prior to the beginning of any work on the interstate or limited access right-of-way.

C. Traffic Control Devices

All traffic control devices used during the construction of a project shall meet the Standards utilized in the MUTCD, and shall comply with the requirements of these Specifications, Project Plans, and Special Provisions. All devices shall be tested at NCHRP Test Level III. Reference is made to Subsections 104.05, 107.07, and 107.09.

D. Reflectorization Requirements

All rigid fluorescent orange construction warning signs (black on fluorescent orange) shall meet the reflectorization and color requirements of ASTM Type VII, VIII, IX or X regardless of the mounting height.

Portable signs which have flexible sign blanks shall meet the reflectorization and color requirements of ASTM Type VI.

Warning signs (W3-1a) for stop conditions that have rumble strips located in the travel way shall be reflectorized with ASTM Type IX fluorescent yellow sheeting.

All other signs shall meet the requirements of ASTM Type III or IV except for "Pass With Care" and "Do Not Pass" signs which may be ASTM Type I unless otherwise specified.

CHANNELIZATION DEVICES: Channelization devices shall meet the requirements of ASTM Type III or IV high intensity sheeting.

E. Implementation Requirements

No work shall be started on any project phase until the appropriate traffic control devices have been placed in accordance with the Project requirements. Changes to traffic flow shall not commence unless all labor, materials, and equipment necessary to make the changes are available on the Project.

When any shift or change is made to the location of traffic or to the flow patterns of traffic, the permanent safety features shall be installed and fully operational before making the change. If staging or site conditions prevent the installation of permanent features then the equivalent interim devices shall be utilized.

Any section of the work that is on new location shall have all permanent safety features installed and fully operational before the work is opened to traffic. Safety features shall include but are not limited to the following items:

- Guardrail including anchors and delineation
- Impact attenuators
- Traffic signals
- Warning devices
- Pavement markings including words, symbols, stop bars, and crosswalks
- Roadway signs including regulatory, warning, and guide

Outdoor lighting shall be considered as a safety feature for welcome centers, rest areas, and weigh station projects. For typical roadway type projects new street lighting is not considered a safety feature unless specifically noted in the plans or in the special conditions.

F. Maintenance of Traffic Control devices

Traffic control devices shall be in acceptable condition when first erected on the project and shall be maintained in accordance with Subsection 104.05 throughout the construction period. All unacceptable traffic control devices shall be replaced within 24 hours. When not in use, all traffic control devices shall be removed, placed or covered so as not to be visible to traffic. All construction warning signs shall be removed within seven calendar days after time charges are stopped or pay items are complete. If traffic control devices are left in place for more than ten days after completion of the Work, the County shall have the right to remove such devices, claim possession thereof, and deduct the cost of such removal from any monies due, or which may become due, the Contractor.

G. Traffic Interruption Restrictions

The County reserves the right to restrict construction operations when, in the opinion of CIS Inc., the continuance of the Work would seriously hinder traffic flow, be needlessly disruptive or unnecessarily inconvenience the traveling public. The Contractor shall suspend and/or reschedule any work when CIS. Inc deems that conditions are unfavorable for continuing the Work.

Advanced notification requirements to the Contractor to suspend work will be according to the events and the time restrictions outlined below:

| | |
|---|-----------------------------|
| Incident management | No advanced notice required |
| Threatening/Inclement weather | 24 hours |
| Holidays, sporting events, unfavorable conditions | Three (3) calendar days |

If the work is suspended, the Contractor may submit a request for additional contract time as allowed under Section 108. The County will review the request and may grant additional contract time as justified by the impact to the Contractor's schedule. Compensation for loss of productivity, rescheduling of crews, rental of equipment or delays to the Contractor's schedule will not be considered for payment. Additional contract time will be the only consideration granted to the Contractor.

H. Sequence of Operations

Any Sequence of Operations provided in this Contract in conjunction with any staging details which may be shown in the plans, is a suggested sequence for performing the Work. It is intended as a general staging plan for the orderly execution of the work while minimizing the impact on the mainline, cross-streets and side streets. The Contractor shall develop detailed staging and traffic control plans for performing specific areas of the Work including but not limited to all traffic shifts, detours, bridge widenings, paces, or other activities that disrupt traffic flow. CIS. Inc. may require detailed staging and traffic control plans for lane closures. These plans shall be submitted for approval at least two weeks prior to the scheduled date of the activity. Activities that have not been approved at least seven (7) days prior to the scheduled date shall be rescheduled.

Where traffic is permitted through the work area under stage construction, the Contractor may choose to construct, at no additional expense to the County, temporary on-site bypasses or detours in order to expedite the work. Plans for such temporary bypasses or detours shall be submitted to CIS. Inc for review and approval 30 calendar days prior to the proposed construction. Such bypasses or detours shall be removed promptly when in the opinion of CIS. Inc; they are not longer necessary for the satisfactory progress of the Work. Bypasses and detours shall meet the minimum requirements of Subsection 150.02.B.4.

As an option to the Sequence of Operations in the Contract, the Contractor may submit an alternative Sequence of Operations for review and approval. A twenty calendar day lead time for the County's review shall be given to this submission so that a decision on its acceptability can be made and presented at the Preconstruction Conference. Insufficient lead time or no submission by the Contractor shall be construed as acceptance of the Sequence of Operations outlined in the Contract and the willingness of the Contractor to execute this as-bid plan.

The County will not pay, or in any way reimburse the Contractor for claims arising from the Contractor's inability to perform the Work in accordance with the Sequence of Operations provided in the Contract or from an approved Contractor alternate.

The Contractor shall secure CIS Inc's approval of the Contractor's proposed plan of operation, sequence of work and methods of providing for the safe passage of vehicular and pedestrian traffic before it is placed in operation. The proposed plan of operation shall supplement the approved traffic control plan. Any major changes to the approved traffic control plan, proposed by the Contractor, shall be submitted to the County for approval.

Some additional traffic control details will be required prior to any major shifts or changes in traffic. The traffic control details shall include, but not be limited to, the following:

1. A detailed drawing showing traffic locations and laneage for each step of the change.
 - a. The location, size, and message of all signs required by the MUTCD, Plan, Special Provisions and other signs as required to fit conditions. Any portable changeable message signs used shall be included in the details.
 - b. The method to be used in, and the limits of, the obliteration of conflicting lines and markings.
4. Type, location, and extent of new lines and markings.
5. Horizontal and vertical alignment and superelevation rates for detours, including cross-section and profile grades along each edge of existing pavement.
6. Drainage details for temporary and permanent alignments.

7. Location, length, and/or spacing of channelization and protective devices (temporary barrier, guardrail, barricades, etc.)
8. Starting time, duration and date of planned change.
9. For each traffic shift, a paving plan, erection plan, or work site plan, as appropriate, detailing workforce, materials, and equipment necessary to accomplish the proposed work. This will be the minimum resource allocation required in order to start the work.

A minimum of three copies of the above details shall be submitted to CIS Inc for approval at least 14 days prior to the anticipated traffic shift. The Contractor shall have traffic control details for a traffic shift which has been approved by CIS Inc prior to commencement of the physical shift. All preparatory work relative to the traffic shift, which does not interfere with traffic, shall be accomplished prior to the designated starting time. CIS Inc and the Contractor's representative will verify that all conditions have been met prior to the Contractor obtaining materials for the actual traffic shift.

I. Compliance dates for provisions of the MUTCD

Federal law requires that traffic control devices (temporary or permanent) installed on new highway or bikeway construction or reconstruction shall be compliant with the latest version of the MUTCD before the road is opened to the public for unrestricted travel. The latest version of the MUTCD is the 2009 Edition, which the Georgia County of Transportation has adopted. However, the FHWA, in the introduction to the MUTCD has established alternate compliance dates for some of the new provisions of the 2009 MUTCD. Below is a list of those compliance dates. The County may decide to require contractors to implement some or all of these provisions at an earlier date than the compliance dates noted below. However notice will be given in advance of the letting date if these provisions are to be implemented prior to the compliance dates. The contractor may also decide to implement the new provisions in the 2009 MUTCD earlier than required by the compliance dates below.

The target dates established by the FHWA shall be as follows:

Section 6D.03 Worker Safety Considerations – high-visibility apparel requirements – December 31, 2011

Section 6E.02 High-Visibility Safety Apparel – high-visibility apparel requirements for flaggers – December 31, 2011.

150.2 Temporary Traffic Control Zones

A. Devices and Materials

In addition to the other provisions contained herein, work zone traffic control shall be accomplished using the following means and materials:

1. Portable Advance Warning Signs

Portable advance warning signs shall be utilized as per the requirements of the traffic control plans. All signs shall meet the requirements of the MUTCD and shall be NCHRP 350 crashworthy compliant.

2. Arrow Panels

Portable sequential or flashing arrow panels as shown in the Plans or Specifications for use on Interstate or multi-lane highway lane closure only, shall be a minimum size of 48" high by 96" wide with not less than 15 lamps used for the arrow. The arrow shall occupy virtually the entire size of the arrow panel and shall have a minimum legibility distance of one mile. The minimum legibility distance is that distance at which the arrow panel can be comprehended by an observer on a sunny day, or clear night. Arrow panels shall be equipped with automatic dimming features for use during hours of darkness. The arrow panels shall also meet the requirements for a Type C panel as shown in the MUTCD. The sequential or flashing arrow panels shall not be used for lane

closure on two-lane, two-way highways when traffic is restricted to one-lane operations in which case, appropriate signing, flaggers and when required, pilot vehicles will be deemed sufficient.

The sequential or flashing arrow panels shall be placed on the shoulder at or near the point where the lane closing transition begins. The panels shall be mounted on a vehicle, trailer, or other suitable support. Vehicle mounted panels shall be provided with remote controls. Minimum mounting height shall be seven feet above the roadway to the bottom of the panel, except on vehicle mounted panels which should be as high as practical.

For emergency situations, arrow display panels that meet the MUTCD requirements for Type A or Type B panels may be used until Type C panels can be located and placed at the site. The use of Type A and Type B panels shall be held to the minimum length of time possible before having the Type C panel(s) in operation. CIS Inc shall determine when conditions and circumstances are considered to be emergencies. The Contractor shall notify CIS Inc, in writing, when any non-specification arrow display panel(s) is being used in the work.

3. **Portable Changeable Message Signs**

Portable changeable message signs meeting the requirements of [Section 632](#) and the MUTCD. Any PCMS in use that is not protected by positive barrier protection shall be delineated by a minimum of three drums that meet the requirement of Subsection 150.05.A.1. The drum spacing shall not exceed a maximum of ten (10') feet as shown in

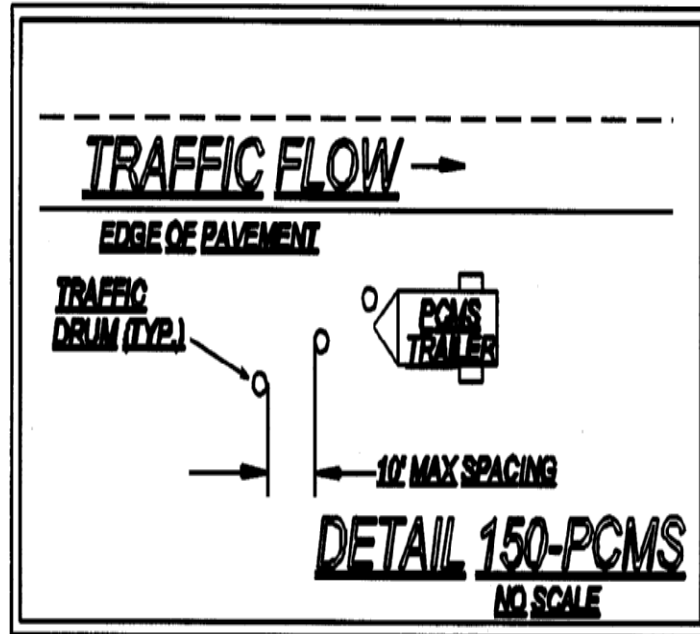

Detail 150-PCMS. When the PCMS is within twenty (20') feet of the opposing traffic flow, the trailing end of the PCMS shall be delineated with a minimum of three drums spaced in the same manner as the approach side of the PCMS.

When not in use the PCMS shall be removed from the roadway unless protected by positive barrier protection. If the PCMS is protected by positive barrier protection the sign panel shall be turned away from traffic when not in use.

4. **Channelization Devices**

Channelization devices shall meet the standards of the MUTCD and Subsection 150.05.

5. **Temporary Barrier**

Temporary barrier shall meet the requirements of Sections 620.

6. **Temporary Traffic Signals**

Temporary traffic signals shall meet the requirements of Section 647 and the MUTCD.

7. **Pavement Marking**

Pavement marking incorporated into the work shall comply with Subsections 150.04.A and 150.04.B.

8. **Portable Temporary Traffic Control Signals**

The use of Portable Temporary Traffic Control Signals shall meet the following minimum requirements:

Only two-lane two-way roadways will be allowed to utilize Portable Temporary Traffic Control Signals.

All portable traffic control signals shall meet the physical display and operational requirements of conventional traffic signals described in the MUTCD.

Each signal face shall have at least three lenses. The lenses shall be red, yellow, or green in color and shall give a circular type of indication. All lenses shall be twelve (12") inches nominal in diameter.

A minimum of two signal faces shall face each direction of traffic. A minimum of one signal head shall be suspended over the roadway travel lane in a manner that will allow the bottom of the signal head housing to be not less than seventeen (17') feet above and not more than nineteen (19') feet above the pavement grade at the center of the travel lane. The second signal head may be located over the travel lane with the same height requirements or the second signal head may be located on the shoulder. When the signal head is located on the shoulder the bottom of the signal head housing shall be at least eight (8') feet but not more than (15') feet above the pavement grade at the center of highway.

Advance warning signage and appropriate pavement markings shall be installed as part of the temporary signal operation.

The signals shall be operated in a manner consistent with traffic requirements. The signals may be operated in timed-mode or in a vehicle-actuated mode. The signals shall be interconnected in a manner to ensure that conflicting movements can not occur. To assure that the appropriate operating pattern including timing is displayed to the traveling public, regular inspections including the use of accurate timing devices shall be made by the Worksite Traffic Control Supervisor. If at any time any part of the system fails to operate within these requirements then the use of the signal shall be suspended and the appropriate flagging operation shall begin immediately.

The Worksite Traffic Control Supervisor (WTCS) shall continuously monitor the portable traffic control signal to insure compliance with the requirements for maintenance under the MUTCD. The signal shall be maintained in a manner consistent with the intention of the MUTCD, with

emphasis on cleaning of the optical system. Timing changes shall be made only by the WTCS. The WTCS shall keep a written record of all timing changes.

The portable temporary signal shall have two power sources and shall be capable of running for seven calendar days continuously.

The Contractor shall have an alternate traffic control plan in the event of failure of the signal.

9. **Rumble Strips**

Rumble strips incorporated into the work shall meet the requirements of Section 429 and the MUTCD. Existing rumble strips that are positioned in the traveled way to warn traffic of a stop condition shall be reinstalled based on the following requirements:

INTERMEDIATE SURFACES: Intermediate surfaces that will be in use for more than forty-five (45) calendar days shall have rumble strips reinstalled on the traveled way in the area of a stop condition. Non-refundable deductions in accordance with Subsection 150.08 will be assessed for any intermediate surface in place for greater than 45 days without rumble strips.

FINAL SURFACES: Rumble strips shall be installed on the final surface within fourteen (14) calendar days of the placement of the final surface in the area of the stop condition. Failure to install within fourteen (14) calendar days will result in assessment of non-refundable deductions in accordance with Subsection 150.08.

Prior to the removal of any rumble strips located in the travel way, stop ahead (W3-1a) warning signs shall be double indicated ahead of the stop condition. These warning signs shall be a minimum of 48 inches by 48 inches. The reflectorization of the warning signs shall be as required by Subsection 150.01.C. These warning signs shall remain in place until the rumble strips have been reinstalled on the traveled way. Any existing warning signs for the stop ahead condition shall be removed or covered while the 48" X 48" (W3-1a) signs are in place. When the rumble strips have been reinstalled these warning signs should be promptly removed and any existing signage placed back in service.

10. **Guardrail**

When the removal and installation of guardrail is required as a part of the work the following time restrictions shall apply unless modified by the special conditions:

MULTI-LANE HIGHWAYS: From the time that the existing guardrail or temporary positive barrier protection is removed the Contractor has fourteen (14) calendar days to install the new guardrail and anchors. During the interim, the location without guardrail shall be protected with drums spaced at a maximum spacing of twenty (20') feet. The maximum length of rail that can be removed at any time without being replaced with positive barrier protection is a total of 2000 linear feet of existing rail or the total length of one run of existing rail, whichever is greater.

ALL OTHER HIGHWAYS: From the time that the existing guardrail is removed or from the time that temporary positive barrier protection is removed the Contractor has thirty (30) calendar days to install the new guardrail and anchors. During the interim, the location without guardrail shall be protected with drums spaced at a maximum spacing of twenty (20') feet. The maximum length of rail that can be removed at any time without being replaced with positive barrier protection is a total of 1000 linear feet of existing rail or the total length of one run of existing rail, whichever is greater.

Based on existing field conditions, CIS Inc may review the work and require that the guardrail be installed earlier than the maximum time allowed above by giving written notification to the Contractor via the TC-1 traffic control report.

Failure to comply with the above time and quantity restrictions shall be considered as non-compliance under Subsection 150.08.

11. **Stop sign regulated intersections**

For intersections that utilize stop sign(s) to control the flow of traffic and to restrict the movement of vehicles, the stop sign(s) shall be maintained for the duration of the work or until such time that the stop condition is eliminated or until an interim or permanent traffic signal can be installed to provide proper traffic control. The traffic signal shall be installed and properly functioning before the removal of the existing stop sign(s) is permitted. If the existing intersection is enhanced traffic control features such as stop bars, double indicated stop signs, oversized signs, advanced warning stop ahead signs, rumble strips on the approaches or flashing beacons located overhead or on the shoulders then these features shall be maintained for the duration of the project or until the permanent traffic control plan has been implemented.

Whenever the staging of the work requires that the traveled-way be relocated or realigned the Contractor shall reinstall all enhanced traffic control features noted above on the newly constructed sections of the work. The cost of relocating the stop bars, stop signs, advanced warning signs, the rumble strips and the flashing beacons shall be included in the price bid for Lump-Sum-Traffic Control unless individual pay items are included in the contract for rumble strips and/or flashing beacons. When pay items are included in the contract for rumble strips or flashing beacons then these items will be paid per each.

When staging requires the relocation or realignment of an existing stop condition it may be necessary to consider the addition of enhanced traffic control features even though none existed at the original location. As a guide for enhanced traffic control features that may be considered, CIS Inc or the WTCS may refer to the County's guidelines for "Opening of New Roadways to Traffic" (Document #6635-2). Horizontal and vertical alignment changes at a new location may have decreased or restricted sight distance or the stop condition may occur sooner than in the previous alignment. If these conditions occur then CIS Inc and/or the WTCS should consider additional measures to enhance the motorist's awareness of the changes even though the staging plans may not address enhanced features. Stop signs should be a minimum of 36 inches for interim situations. The use of 48 inch stop signs may be warranted under project specific conditions. Flags may be used on interim/permanent stop signs that are mounted at seven (7') feet in height for a short duration in order to direct additional attention to a new or relocated stop sign(s). Flags should not be used for durations exceeding two weeks unless unusual or site specific conditions warrant a longer period of time. The use of Type "A" flashing red light(s) attached to the stop sign(s) may be appropriate during the same period that the flags are in use to increase attention.

The use of rumble strips and/or portable changeable message signs may be considered. The use of new rumble strips, where none previously existed, shall have the prior approval of District Traffic Operations before being included as part of the traffic control plan. The message(s) displayed on any PCMS shall have the prior approval of CIS Inc and the message(s) shall be included as part of the traffic control plan for the interim staging.

The placement of any additional interim ground-mounted signs and posts or stop bars shall be considered as incidental to the price bid for Lump Sum-Traffic Control. The installation of rumble strips, flashing beacons or the use of Portable Changeable Message Signs (PCMS) shall be considered as Extra Work unless pay items are included in the contract.

B. Work zone restrictions

1. **Interstate**

The Contractor shall not simultaneously perform work on both the inside shoulder and outside shoulder on either direction of traffic flow when the Work is within 12 feet of the travel-way, unless such areas are separated by at least one-half mile of distance.

2. **Non-Interstate Divided Highways**

The Contractor shall not simultaneously perform work on both the inside shoulder and outside shoulder on either direction of traffic flow when the Work is within 12 feet of the travel-way, unless such areas are separated by at least one-half mile distance in rural areas or at least 500 feet of distance in urban areas.

3. **Non-Divided Highways**

The Contractor shall not simultaneously perform work on opposite sides of the roadway when the work is within 12 feet of the travel-way, unless such areas are separated by at least one-half mile of distance in rural areas or at least 500 feet of distance in urban areas.

On two-lane projects where full width sections of the existing subgrade, base or surfacing are to be removed, and new base, subgrade, or surfacing are to be constructed, the Contractor shall maintain one-lane traffic through the construction area by removing and replacing the undesirable material for half the width of the existing roadway at a time. Replacement shall be made such that paving is completed to the level of the existing pavement in the adjacent lane by the end of the workday or before opening all the roadway to traffic.

4. **All Highways:**

a. There shall be no reduction in the total number of available traffic lanes that existed prior to construction except as specifically allowed by the Contract and as approved by CIS Inc.

b. Travel way Clearances: All portions of the work shall maintain the following minimum requirements:

Horizontal: The combined dimensions of the paved shoulder and the roadway surface remaining outside the Work Zone shall be no less than sixteen (16) feet in width at any location.

Vertical: The overhead clearance shall not be reduced to less than fifteen (15) feet at any location.

The restrictions above apply to all shifts, lane closures, on-site detours and off site detours whether shown in the contract or proposed by the Contractor. It shall be the responsibility of the Contractor to verify that these minimum requirements have been met before proceeding with any phase of the Work.

Two-lane two-way roadways may have temporary horizontal restrictions of less than sixteen (16) feet provided a flagger operation for one-way traffic is utilized to restrict access to the work area by over-width loads. The minimum horizontal clearance shall be restored before the flagging operation is removed.

c. Highway Work Zone: All sections or segments of the roadway under construction or reconstruction shall be signed as a Highway Work Zone except non-state highway two-lane two-way resurfacing projects. Two conditions can be applied to a Highway Work Zone. Condition 1 is when no reduction in the existing speed limit is required. Condition 2 is when worksite conditions require a reduction of the speed limit through the designated Work Zone. Properly marking a Highway Work Zone shall include the following minimum requirements:

1) **NO REDUCTION IN THE EXISTING POSTED SPEED LIMIT IN HIGHWAY WORK ZONE:**

a) Signage (Detail 150-HWZ-2) shall be posted at the beginning point of the Highway Work Zone warning the traveling public that increased penalties for speeding

violations are in effect. The HWZ-2 sign shall be placed a minimum of six hundred (600') feet in advance of the Highway Work Zone and shall not be placed more than one thousand (1000') feet in advance of the Work Zone. If no speed reduction is required it is recommended that the HWZ-2 be placed at 750 feet from the work area between the ROAD WORK 500 FT. and the ROAD WORK 1000 FT. signs.

HWZ-2 signs shall be placed at intervals not to exceed one mile for the length of the project. HWZ-2 signs should be placed on the mainline after all major intersections except State Routes. State Routes shall be signed as per the requirements for intersecting roadways below.

- b) The existing speed limit shall be posted at the beginning of the Work Zone. Existing Speed Limit signs (R2-1) shall be maintained.
 - c) INTERSECTING ROADWAYS: Intersecting state routes shall be signed in advance of each intersection with the Work Zone with a HWZ-2 sign to warn motorists that increased fines are in effect. All other intersecting roadways that enter into a designated Highway Work Zone may be signed in advance of each intersection with the Work Zone. When construction equipment and personnel are present in the intersection on the mainline of a multi-lane roadway, the intersecting side roads shall be signed in advance with HWZ-2 signs. As soon as the work operation clears the intersection the signage may be removed.
 - d) Signage (Detail 150-HWZ-3) shall be posted at the end of the Highway Work Zone indicating the end of the zone and indicating that increased penalties for speeding violations are no longer in effect.
 - e) When a designated Highway Work Zone is no longer necessary all signs shall be removed immediately.
2. REDUCING THE SPEED LIMIT IN A HIGHWAY WORK ZONE:
Highway Work Zone signs shall be posted as required in Condition 1 above.

For limited access (interstate) highways and controlled access multi-lane divided highways the posted speed limit shall be reduced as required below.

Speed Limit signage (R2-1) for the reduced speed limit shall be erected at the beginning of the work zone. Additional signs shall be placed to ensure that the maximum spacing of the reduced speed limit signs shall be no greater than one (1) mile apart. Existing speed limit signs shall be covered or removed. On multi-lane divided highways the speed limit signs shall be double indicated when the reduced speed is in use.

When any one or more of the following conditions exist and the existing speed limit is 65 mph or 70 mph, the speed limit shall be reduced by 10 mph. If the existing speed limit is 60 mph, the speed limit should be reduced by 5 mph. If the existing speed limit is 55 mph or less, the Contractor can only reduce the speed limit with the prior approval of CIS Inc. The reduction in the speed limit shall be no greater than 10 mph:

- a) Lane closure(s) of any type and any duration.
- b) The difference in elevation exceeds two inches adjacent to a travel lane as shown in Subsection 150.06, Detail 150-B, 150-C.
- c) Any areas where equipment or workers are within ten feet of a travel lane.
- d) Temporary portable concrete barriers located less than two (2') feet from the traveled way.
- e) As directed by CIS Inc for conditions distinctive to this project.

When the above conditions are not present the speed limit shall be immediately returned to the existing posted speed limit. A speed reduction shall not be put in place for the entire length of the project unless conditions warranting the speed reduction are present

for the entire project length. All existing speed limit signs within the temporary speed reduction zone shall be covered or removed while the temporary reduction in the speed limit is in effect. All signs shall be erected to comply with the minimum requirements of the MUTCD.

As a minimum the following records shall be kept by the WTCS:

- a) Identify the need for the reduction.
- b) Record the time of the installation and removal of the temporary reduction.
- c) Fully describe the location and limits of the reduced speed zone.
- d) Document any accident that occurs during the time of the reduction.

A copy of the weekly records for reduced speed zones shall be submitted to CIS Inc.

Reduced speed zones shall, as a minimum, be signed as per Detail 150-HWZ-1. Interim signs shall meet the requirements of Subsection 150.03.D. Additional signs may be necessary to adjust for actual field conditions.

When a pilot vehicle is used on a two-lane two-way roadway the speed limit should not be reduced. For special conditions specific to the work, on two-lane two-way roadways or multi-lane highways, the contractor may reduce the posted speed limit with the prior approval of CIS Inc.

5. **Milled surface restrictions:**

Unless modified by the special conditions, a milled surface on any asphaltic concrete surface shall not be allowed to remain open to traffic for a period of time that exceeds thirty (30) calendar days.

6. **Installation/Removal of work area signage:**

No payment will be made for Traffic Control-Lump Sum until the Work has actually started on the project. The installation of traffic control signage does not qualify as the start of work. Advanced warning signs shall not be installed until the actual beginning of work activities. Any permanent mount height signs installed as the work is preparing to start shall be covered until all signs are installed unless all signs are installed within seven (7) calendar days after beginning installation.

All temporary traffic control devices shall be removed as soon as practical when these devices are no longer needed. When work is suspended for short periods of time, temporary traffic control devices that are no longer appropriate shall be removed or covered.

All construction warning signs shall be removed within seven (7) calendar days after time charges are stopped or pay items are complete. If traffic control devices are left in place for more than ten (10) calendar days after completion of the Work, the County shall have the right to remove such devices, claim possession thereof, and deduct the cost of such removal from any monies due, or which may become due, the Contractor.

PUNCHLIST WORK: Portable signs shall be utilized to accomplish the completion of all punch list items. The portable signs shall be removed daily. All permanent mount height signs shall be removed prior to the beginning of the punch list work except "Low/Soft Shoulder" signs and any signs that have the prior written approval of CIS Inc to remain in place while the punch list work is in progress.

Failure to promptly remove the construction warning signs within the seven (7) calendar days after the completion of the Work or failure to remove or cover signs when work is suspended for short periods of time shall be considered as non-performance under Subsection 150.08.

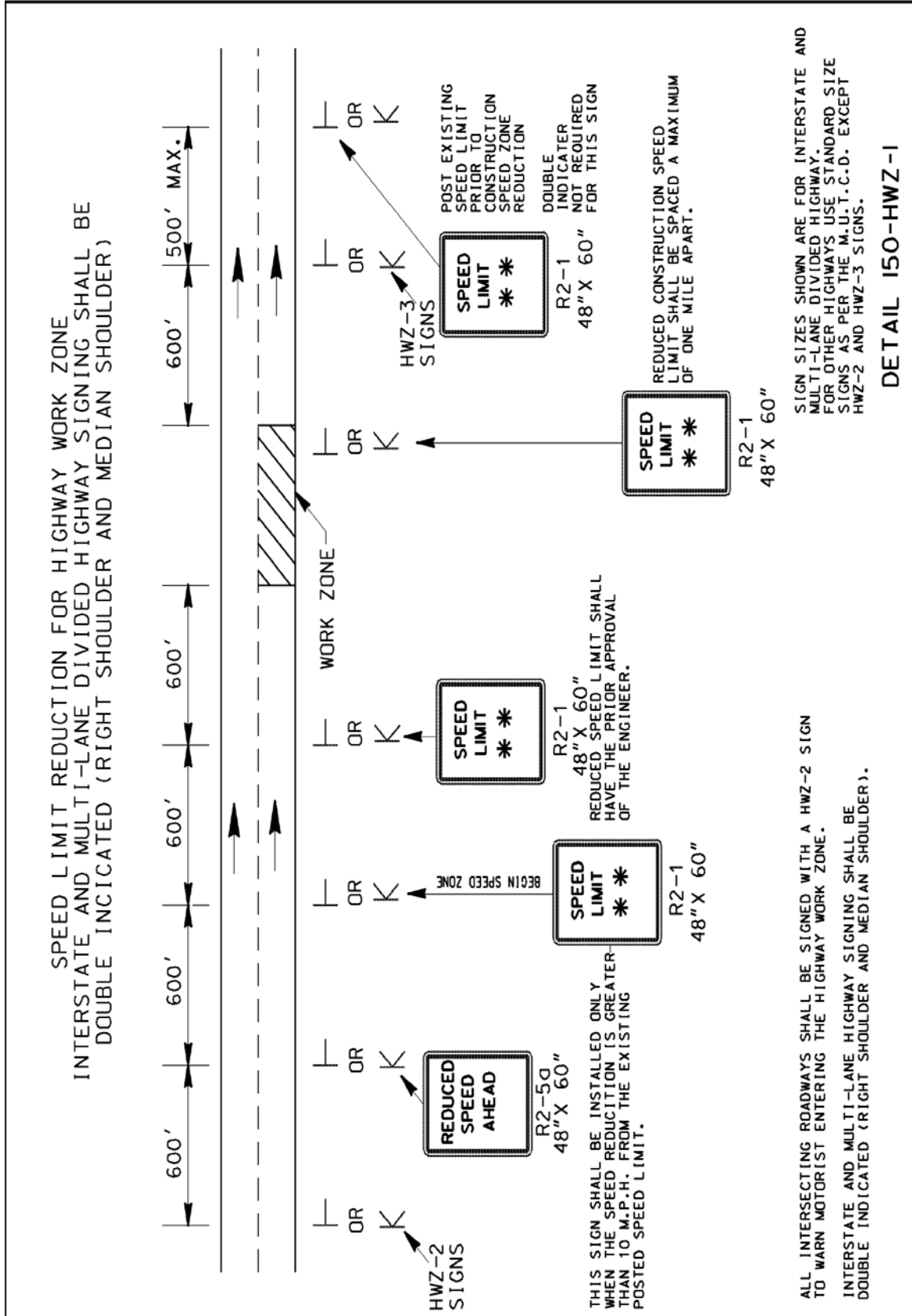

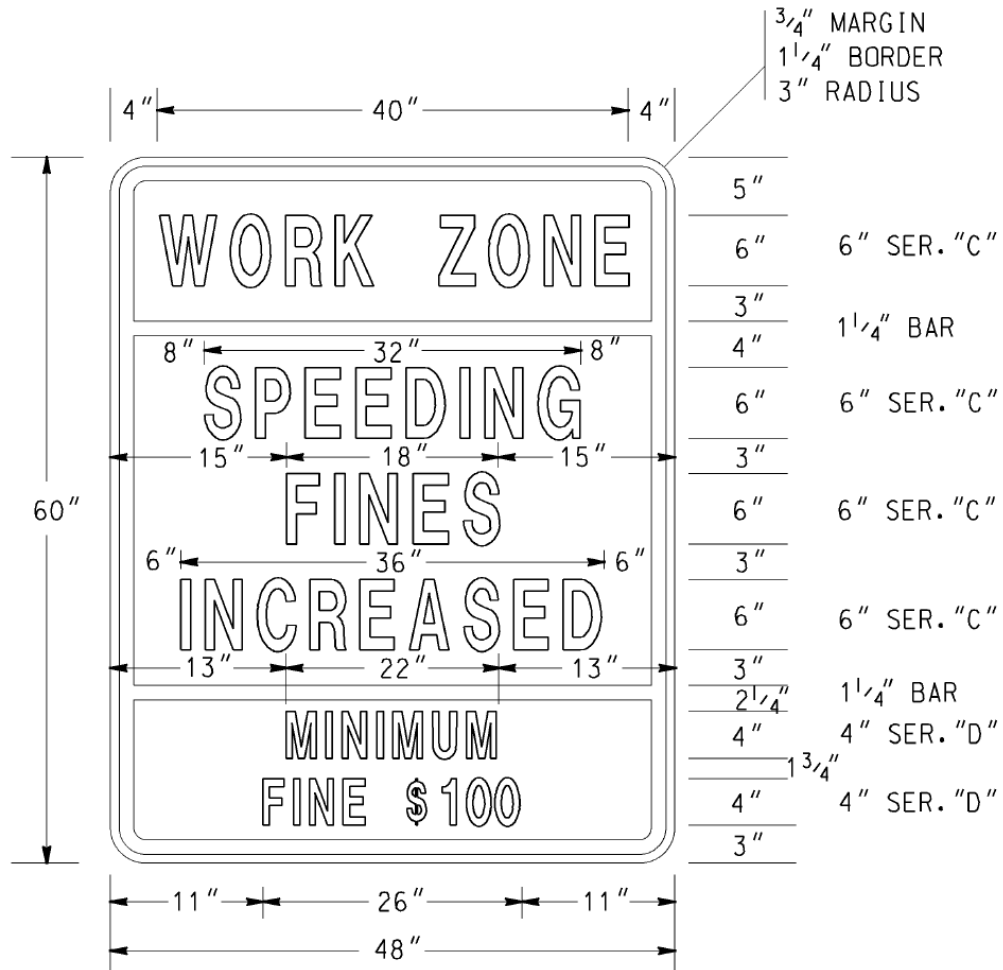

HWZ-2

COLORS
TOP PANEL

LEGEND & BORDER - BLACK (NON-REFL)
BACKGROUND - FLUORESENT ORANGE
(ASTM TYPE VII, VIII, IX or X)

MIDDLE & BOTTOM PANELS

LEGEND & BORDER - BLACK (NON-REFL)
BACKGROUND - WHITE (ASTM TYPE III OR IV REFL SHEETING)

NOTES:

1. ALL HWZ-2 SIGN PANELS SHALL BE RIGID.
2. THE SIZE OF THE HWZ-2 SIGN SHALL NOT BE REDUCED FOR USE ON TWO-LANE ROADWAYS.

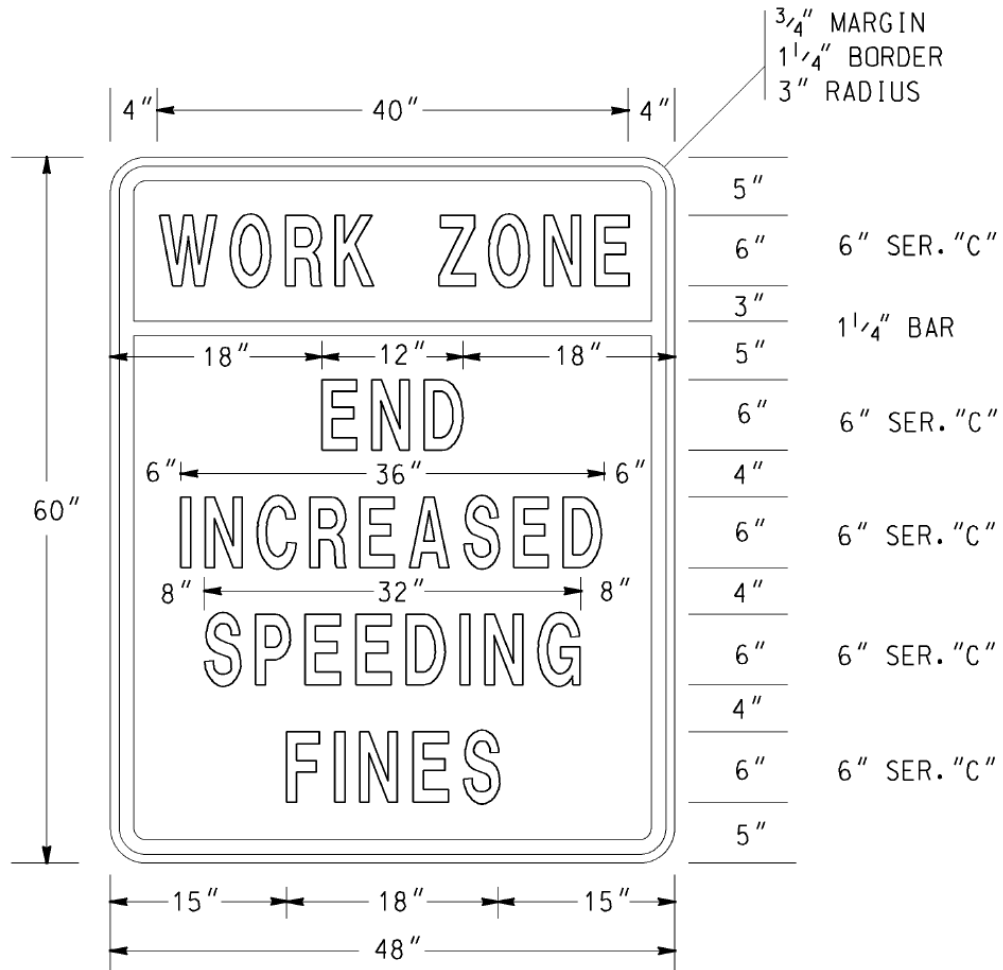

HWZ-3

COLORS

TOP PANEL

LEGEND & BORDER - BLACK (NON-REFL)
 BACKGROUND - FLUORESENT ORANGE
 (ASTM TYPE VII, VIII, IX or X)

BOTTOM PANEL

LEGEND & BORDER - BLACK (NON-REFL)
 BACKGROUND - WHITE (ASTM TYPE III OR IV REFL SHEETING)

NOTES:

1. ALL HWZ-3 SIGN PANELS SHALL BE RIGID.
2. THE SIZE OF THE HWZ-3 SIGN SHALL NOT BE REDUCED FOR USE ON TWO-LANE ROADWAYS.

C. Lane closures

1. Approval/Restrictions

All lane closures of any type or duration shall have the prior approval of CIS Inc.

- a. The length of a lane closure shall not exceed two (2) miles in length excluding the length of the tapers unless the prior approval of CIS Inc has been obtained. CIS Inc may extend the length of a lane closure based upon field conditions however the length of a work zone should be held to the minimum length required to accomplish the Work. Lane closures shall not be spaced closer than one mile. The advanced warning signs for the project should not overlap with the advanced warning signs for lane shifts, lane closures, etc.
- b. Lane closures that require same direction traffic to be split around the Work Area will not be approved for roadways with posted speeds of 35 mph or greater, excluding turn lanes.

2. Removal Of Lane Closures

To provide the greatest possible convenience to the public in accordance with Subsection 107.07, the Contractor shall remove all signs, lane closure markings, and devices immediately when lane closure work is completed or temporarily suspended for any length of time or as directed by CIS Inc. All portable signs and portable sign mounting devices shall be removed from the roadway to an area which will not allow the sign to be visible and will not allow the sign or sign mounting device to be impacted by traffic.

3. Exit And Entrance Ramps

On multilane highways where traffic has been shifted to the inside lanes, the exit and entrance ramps shall have channelization devices placed on both sides of the ramp. The temporary ramp taper length shall be greater than, or equal to, the existing taper length. Interim EXIT gore signs shall be placed at the ramp divergence. The "EXIT OPEN" sign shown in Figure TA-42 of the MUTCD shall be utilized. Channelization device spacing shall be 10 feet for 200 feet in advance of the temporary gore, and 10 feet for the first 100 feet of the temporary gore.

4. Lane Drop/Lane Closure

The first seven (7) calendar days of any lane closure shall be signed and marked as per Standard 9106 or 9107. However, lane closures that exist for a duration longer than seven (7) calendar days may be signed and marked as per the details in Standard 9121, provided the prior approval of CIS Inc is obtained. The approved lane drop shall utilize only the signs and markings shown for the termination end of the lane drop in Standard 9121. All warning signs in the lane drop sequence shall be used. Drums may be substituted for the Type I Crystal Delineators at the same spacing.

5. Termination Area

The transition to normal or full width highway at the end of a lane closure shall be a maximum of 150 feet.

D. Traffic pacing method

1. Pacing Of Traffic

With prior approval from CIS Inc, traffic may be paced allowing the Contractor up to ten (10) minutes maximum to work in or above all lanes of traffic for the following purposes:

- a. Placing bridge members or other bridge work.
- b. Placing overhead sign structures.
- c. Other work items requiring interruption of traffic.

The Contractor shall provide a uniformed police officer with patrol vehicle and blue flashing light for each direction of pacing. The police officer, CIS. Inc, and flaggers at ramps shall be provided with a radio which will provide continuous contact with the Contractor.

When ready to start the work activity, the police vehicle will act as a pilot vehicle slowing the traffic thereby providing a gap in traffic allowing the Contractor to perform the Work. Any on-ramps between the pace and the work area shall be blocked during pacing of traffic, with a flagger properly dressed and equipped with a Stop/Slow paddle. Each ramp should be opened after the police vehicle has passed.

Pilot vehicles shall travel at a safe pace speed, desirably not less than 20 mph interstate and 10 mph non-interstate. The Contractor shall provide a vehicle to proceed in front of the police vehicle and behind the other traffic in order to inform the Contractor's work force when all vehicles have cleared the area.

Traffic will not be permitted to stop during pacing except in extreme cases as approved by CIS Inc.

2. **Methods Of Signing For Traffic Pacing**

At a point not less than 1,000 feet in advance of the beginning point of the pace, the Contractor shall erect and cover a W-special sign (72 inch x 72 inch) with a Type "B" flashing light, with the legend "TRAFFIC SLOWED AHEAD SHORT DELAY" (See Detail 150-A). A portable changeable message sign may be used in lieu of the W-special sign. On divided highways this sign shall be double indicated. A worker with a two-way radio shall be posted at the sign, and upon notice that the traffic is to be paced shall turn on the flashing light and reveal the sign. When traffic is not being paced, the flashing light shall be turned off and the sign covered or removed. W-special signs are reflectorized black on orange, Series "C" letter and border of the size specified.

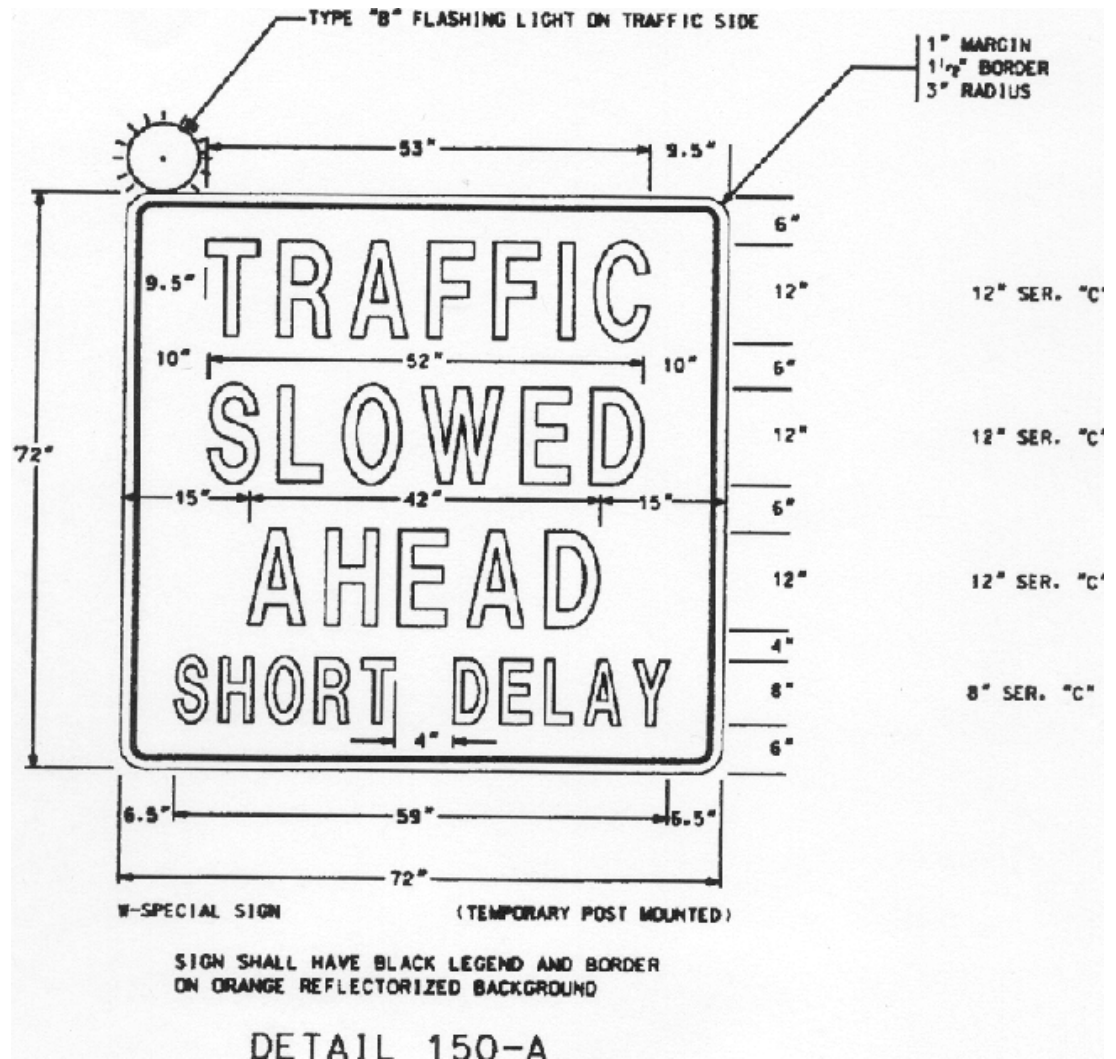

E. Construction vehicle traffic

The Contractor's vehicles shall travel in the direction of normal roadway traffic and shall not reverse direction except at intersections, interchanges, or approved temporary crossings. The Contractor may submit a plan requesting that construction traffic be allowed to travel in the opposite direction of normal traffic when it would be desirable to modify traffic patterns to accommodate specific construction activities.

Prior approval of CIS Inc shall be obtained before any construction traffic is allowed to travel in a reverse direction. If the Contractor's submittal is approved the construction traffic shall be separated from normal traffic by appropriate traffic control devices.

F. Environmental impacts to the traffic control plan

The Contractor shall ensure that dust, mud, and other debris from construction activities do not interfere with normal traffic operations or adjacent properties. All outfall ditches, special ditches, critical storm drain structures, erosion control structures, retention basins, etc. shall be constructed, where possible, prior to the beginning of grading operations so that the best possible drainage and erosion control will be in effect during the grading operations, thereby keeping the roadway areas as dry as possible.

Areas within the limits of the project which are determined by CIS Inc to be disturbed or damaged due either directly or indirectly from the progress or the lack of progress of the work shall be cleaned up, redressed, and regressed. All surplus materials shall be removed and disposed of as required. Surplus materials shall be disposed of in accordance with Subsection 201.02.E.3 of the Specifications.

G. Existing street lights

Existing street lighting shall remain lighted as long as practical and until removal is approved by CIS Inc.

H. Night work

Adequate temporary lighting shall be provided at all nighttime work sites where workers will be immediately adjacent to traffic. For their own protection, workers in or adjacent to traffic during nighttime operation shall wear reflectorized vests that meet the requirements of the MUTCD.

I. Construction vehicles in the work zone

The parking of Contractor's and/or workers personal vehicles within the work area or adjacent to traffic is prohibited. It shall be the responsibility of the Worksite Traffic Control Supervisor to ensure that any vehicle present at the worksite is necessary for the completion of the work.

J. Encroachments on the traveled-way

The Worksite Traffic Control Supervisor (WTCS) shall monitor the work to ensure that all the rocks, boulders, construction debris, stockpiled materials, equipment, tools and other potential hazards are kept clear of the travel way. These items shall be stored in a location, in so far as practical, where they will not be subject to a vehicle running off the road and striking them.

K. Pedestrian access to the work

All existing pedestrian walkways shall be maintained. Whenever changes to the worksite necessitate changes to existing walkways, temporary walkways shall be provided and maintained, with appropriate signs as necessary, to allow safe passage of pedestrian traffic.

L. Traffic Signals

If the sequence of operations, staging, or the traffic control plan requires the relocation or shifting of any components of an existing traffic signal system then any work on these traffic signals will be considered as part of Lump Sum- Traffic Control. The contractor becomes responsible for the maintenance of these traffic signals from the time that the system is modified until final acceptance. The maintenance of traffic signals that are not a part of the work and are not in conflict with any portion of the work shall not be the responsibility of the contractor.

When construction operations necessitate an existing traffic signal to be out of service, the Contractor shall furnish off-duty police officers to regulate and maintain traffic control at the site.

M. Removal/Reinstallation of miscellaneous items

In the prosecution of the Work, if it becomes necessary to remove any existing signs, markers, guardrail, etc. not covered by specific pay item, they shall be removed, stored and reinstalled, when directed by CIS Inc, to line and grade, and in the same condition as when removed.

150.3 Signs

A. Signing requirements of the traffic control plan

When existing regulatory, warning or guide signs are required for proper traffic control the Contractor shall maintain these signs in accordance with the traffic control plan. The Contractor shall review the status of all existing signs, interim signs added to the work, and permanent sign installations that are part of the work to eliminate any conflicting or non-applicable signage in the Traffic Control Plan. The

Contractor's review of all signs in the Traffic Control Plan shall establish compliance with the requirements of the MUTCD and Section 150. Any conflicts shall be reported to CIS Inc immediately and the WTCS shall take the necessary measures to eliminate the conflict.

The Contractor shall make every effort to eliminate the use of interim signs as soon as the Work allows for the installation of permanent signs.

All existing illuminated signs shall remain lighted and be maintained by the Contractor.

Existing street name signs shall be maintained at street intersections.

B. Conflicting or non-applicable signs

Any sign(s) or portions of a sign(s) that are not applicable to the traffic control plan shall be covered so as not to be visible to traffic or shall be removed from the roadway when not in use. The WTCS shall review all traffic shifts and changes in the traffic patterns to ensure that all conflicting signs have been removed. The review shall confirm that the highest priority signs have been installed and that signs of lesser significance are not interfering with the visibility of the high priority signs. High priority signs include signs for road closures, shifts, detours, lane closures and curves. Any signs, such as speed zones and speed limits, passing zones, littering fines and litter pick up, that reference activities that are not applicable due to the presence of the Work shall be removed, stored and reinstalled when the Work is completed.

Failure to promptly eliminate conflicting or non-applicable signs shall be considered as non-performance under Subsection 150.08.

C. Removal of existing signs and supports

The Contractor shall not remove any existing signs and supports without prior approval from CIS Inc. All existing signs and supports which are to be removed shall be stored and protected if this material will be required later in the work as part of the traffic control plan. If the signs are not to be utilized in the work then the signs will become the property of the Contractor unless otherwise specified in the contract documents.

D. Interim guide, warning and regulatory signs

Interim guide, warning, or regulatory signs required to direct traffic shall be furnished, installed, reused, and maintained by the Contractor in accordance with the MUTCD, the Plans, Special Provisions, Special Conditions, or as directed by CIS Inc. These signs shall remain the property of the Contractor. The bottom of all interim signs shall be mounted at least seven (7') feet above the level of the pavement edge when the signs are used for long-term stationary operations as defined by Section 6G.02 of the MUTCD. Special Conditions under Subsection 150.11 may modify this requirement.

Portable signs may be used when the duration of the work is less than three (3) days or as allowed by the special conditions in Subsection 150.11. Portable signs shall be used for all punch list work. All portable signs and sign mounting devices utilized in work shall be NCHRP 350 compliant. Portable interim signs shall be mounted a minimum of one (1') foot above the level of the pavement edge for directional traffic of two (2) lanes or less and a minimum of seven (7') feet for directional traffic of three (3) or more lanes. Signs shall be mounted at the height recommended by the manufacturer's crashworthy testing requirements. Portable interim signs which are mounted at less than seven (7') feet in height may have two 18 inch x 18 inch fluorescent red-orange or orange-red warning flags mounted on each sign.

All regulatory sign blanks shall be rigid whether the sign is mounted as a portable sign, on a Type III barricade or as a permanent mount height sign.

Any permanent mount height interim sign that is designed to fold in half to cover a non-applicable message on the sign shall have reflectorized material on the folded over portion of the sign. The reflectorized material shall be orange in color with a minimum of ASTM Type I .grade sheeting with a minimum area of six inches by six inches (6" x 6") facing the direction of traffic at all times when the sign is folded.

Interim signs must be in English dimensions.

E. Existing special guide signs

Existing special guide signs on the Project shall be maintained until conditions require a change in location or legend content. When change is required, existing signs shall be modified and continued in use if the required modification can be made within existing sign borders using design requirements (legend, letter size, spacing, border, etc.) equal to that of the existing signs, or of Sub-Section 150.03.E.2. Differing legend designs shall not be mixed in the same sign.

1. Special Guide Signs

Special guide signs are those expressway or freeway guide signs that are designed with a message content (legend) that applies to a particular roadway location. When an existing special guide sign is in conflict with work to be performed, the Contractor shall remove the conflicting sign and reset it in a new, non-conflicting location which has been approved by CIS Inc.

2. Interim Special Guide Signs

When it is not possible to utilize existing signs, either in place or relocated, the Contractor shall furnish, erect, maintain, modify, relocate, and remove new interim special guide signs in accordance with the Plans or as directed by CIS Inc. Interim special guide signs that may be required in addition to, or a replacement for, existing expressway and freeway (interstate) signs shall be designed and fabricated in compliance with the minimum requirements for guide signing contained in Part 2E "Guide Signs Expressway" and Part 2F "Guide Signs Freeways" of the MUTCD, except that the minimum size of all letters and numerals in the names and places, streets and highways on all signs shall be 16 inches Series "E" initial upper-case and 12 inches lower-case. All interstate shields on these signs shall be 48 inches and 60 inches for two-numeral and three-numeral routes, respectively.

The road name of the exit or route shield shall be placed on the exit gore sign.

3. Interim Overhead Guide Sign Structures

Interim overhead special guide sign structures are not required to be lighted unless specifically required by the Plans. If lighting is required the sign shall be lighted as soon as erected and shall remain lighted, during the hours of darkness, until the interim sign is no longer required. The Contractor shall notify the Power Company at least thirty (30) days prior to desired connection to the power source.

4. Permanent Special Guide Signs

The installation of new permanent special guide signs and the permanent modification or resetting of existing special guide signs, when included in the contract, shall be accomplished as soon as practical to minimize the use of interim special guide signs. If lighting is required by the Plans, all new permanent overhead special guide signs shall be lighted as soon as erected.

F. Materials-Interim signs

1. Posts

Permanent mounting height of seven (7') feet- Posts for all interim signs shall meet the requirements of Section 911 except that green or silver paint may be used in lieu of galvanization for steel posts or structural shape posts. Within the limits of a single project, all metal posts shall be the same color. Wood posts are not required to be pressure treated.

Interim posts must be in English dimensions.

Posts for all interim signs shall be constructed to yield upon impact unless the posts are protected by guardrail, portable barrier, impact attenuator or other type of positive barrier protection. Unprotected posts shall meet the breakaway requirements of the "1994 AASHTO Standard Specifications for Structural Support for Highway Signs, Luminaries and Traffic Signals". Unprotected interim posts shall be spliced as shown in Detail 150-F unless full length unspliced posts are used.

Unprotected post splices will not be permitted any higher than four inches above the ground line to lessen the possibility of affecting the undercarriage of a vehicle. Installation of posts may require establishment of openings in existing pavements, islands, shoulders etc.

2. **Sign Blanks And Panels- Permanent mounting height of seven (7') feet-**

All sign blanks and panels shall conform to Section 912 of the Specifications except that blanks and panels may be ferrous based or other metal alloys. Type 1 and Type 2 sign blanks shall have a minimum thickness of 0.08 inches regardless of the sign type used. Alternative sign blank materials (composites, poly carbonates, fiberglass reinforced plastics, recycled plastics, etc.) shall have a letter of approval from the Office of Materials and Research for use as interim construction signs before these materials are allowed to be incorporated into the work unless these rigid sign blanks are currently approved as a crashworthy sign blank material under QPL 34. The back side of sign panels shall be painted orange to prevent rust if other metals are used in lieu of aluminum. Plywood blanks or panels will not be permitted. The use of flexible signs will not be permitted for permanent mount height signs.

Interim blanks and panels may be either metric or English in dimensions.

3. **Portable Sign Mounting Devices, Portable Sign Blanks-**

All portable sign mounting devices and sign blanks utilized in the work shall be NCHRP 350 Test Level III compliant. All portable sign mounting devices and sign blanks shall be from the Qualified Products List. Any sign or sign mounting device shall have an identifying decal, logo, or manufacturer's stamping that clearly identifies the device as NCHRP 350 compliant. The Contractor may be required to provide certification from the Manufacturer as proof of NCHRP 350 compliance. All portable signs shall be mounted according to height requirements of Subsection 150.03.D.

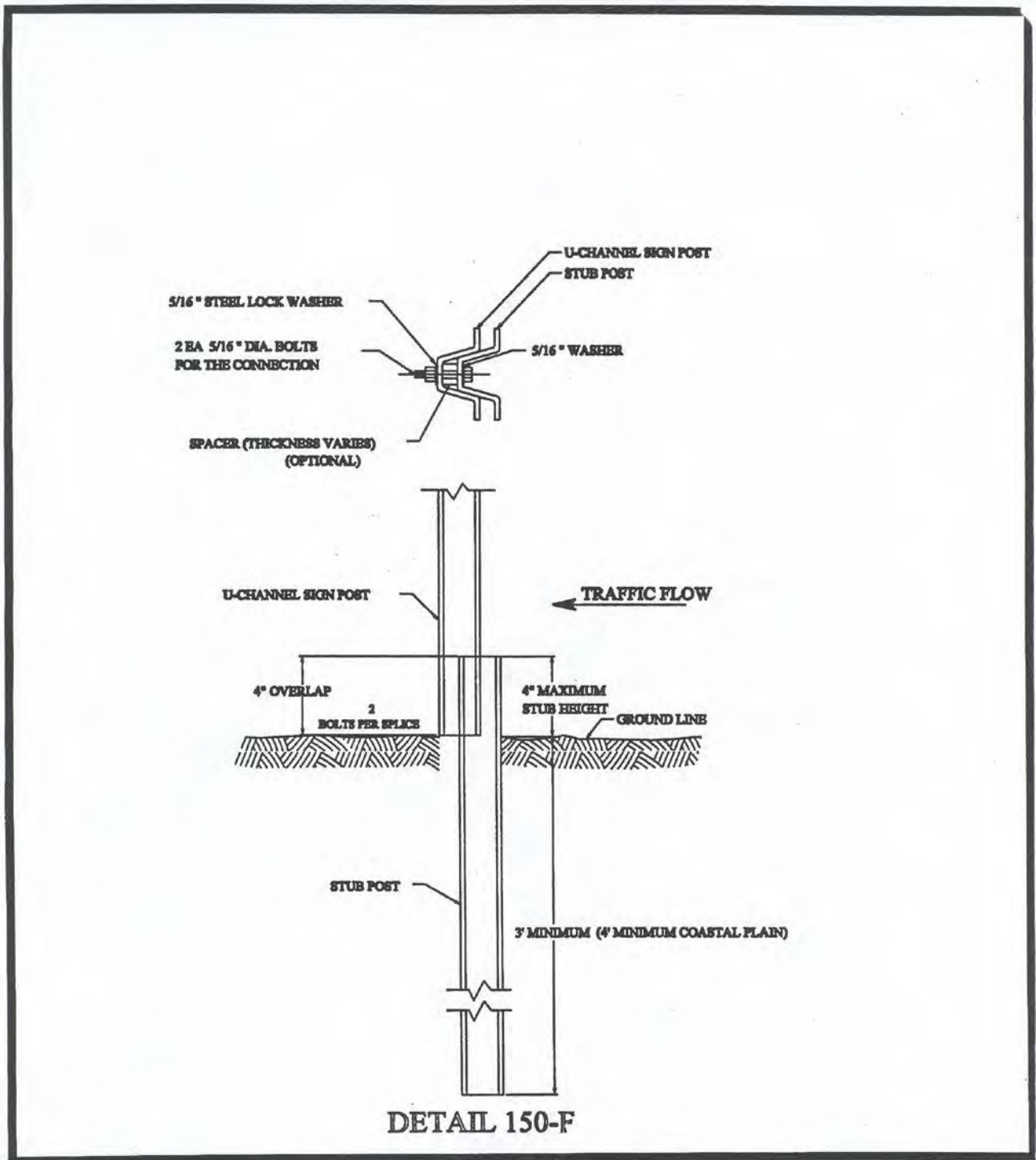

G. Sign visibility and offsets

All existing, interim and new permanent signs shall be installed so as to be completely visible for an advance distance in compliance with the MUTCD. Any clearing required for maintaining the line of sight to existing, interim or permanent signs shall be done as part of the requirements of the traffic control plan. The clearing shall include any advance warning signs, both interim and permanent, that are installed as a part of the work including advance warning signs that are installed outside the limits of the project. Any sign installed behind W-beam or T-beam guardrail with non-breakaway posts shall

be installed with the leading edge of the sign a minimum of four feet and three inches (4'3") behind the face of the guardrail with five feet (5') of clearance being desirable. Limbs, brush, construction equipment and materials shall be kept clear of the driver's line of sight to all signs that are part of the traffic control plan.

H. Advance warning signs

1. All Type Of Highways

Advance warning signs shall be placed ahead of the work area in accordance with Part VI of the MUTCD and shall include a series of at least three advance road work (W20-1) signs placed at the termini of the project. The series shall have the legend ROAD WORK (1500 FEET, 1000 FEET, AND 500 FEET).

At grade intersecting roadways and on-ramps shall be signed with a minimum of one ROAD WORK AHEAD sign.

When work terminates at a "T" intersection, a minimum of one "ROAD WORK AHEAD" sign shall be placed in advance of the intersection and one "END ROAD WORK" sign shall be placed at the termination end of the intersection. Field conditions may require the use of additional warning signage.

Advanced Warning Signs on State Routes shall be a minimum dimension of 48 inches x 48 inches. When a State Route intersects a project which consists of adding travel lanes, reconstructing an existing roadway or new location work, the State Route approaches shall have a minimum of three (W20-1) advanced warning signs (1500 ft., 1000 ft., 500 ft.). The termination end of an intersecting State Route shall have END ROAD WORK signage.

The W20-1 signs shall be placed at the termini of the project or sufficiently in advance of the termini to allow for lane shifts, lane closures and other activities which may also require advanced warning signs. The advanced warning signs for the project should not overlap with the advanced warning signs for lane shifts, lane closures, etc.

The length of a work zone should be held to the minimum length required to accomplish the work. If a project has multiple individual worksites within the overall limits of the project, each site should be signed individually if the advance warning signs for each site can be installed without overlapping an adjacent worksite. As soon as the work is completed at any individual site the warning signs shall be removed from that site. Clean-up work and punch list work shall be performed with portable signage.

Project mileage indicated on the G20-1 sign shall be the actual project mileage rounded up to the nearest whole mile. Projects less than two (2) miles in length or individual worksites that are part of a multiple worksite project may delete this sign. The G20-1 sign shall be 60" X 36" and the G20-2 sign shall be 48" X 24".

2. Interstate, Limited Access And Multilane Divided Highways

In addition to the W20-1 signs required at 500 ft., 1000 ft. and 1500 ft., multi-lane divided highways shall also have additional advanced warning signs installed with the legend "ROAD WORK (2 MILES, 1 MILE and 1/2 MILE). All construction warning signs on divided highways shall be double indicated (i.e., on the left and right sides of the roadway.) If the use of the 1/2 mile, 1 mile and 2 mile advanced warning signs cause an overlap with other work or do not benefit field conditions then CIS Inc may review the use of these signs and eliminate their installation.

When the posted speed limit is 50 MPH or less, the 1/2 mile, 1 mile and 2 mile signs should be eliminated especially in urban areas.

The W20-1 advance warning signs for ROAD WORK 500 FEET; 1000 FEET; and 1500 FEET shall be temporarily covered when work involving the advanced warning signs for lane shifts and lane closures overlap these signs. The ROAD WORK ½ MILE, ROAD WORK 1 MILE, and ROAD WORK 2 MILES shall be in place when the 500, 1000 and 1500 feet signs are temporarily covered.

When the temporary traffic control zone already has advanced warning (W20-1) signs installed the W20-1 signs required for lane closures under Standard 9106 should be eliminated.

RAMP WORK ON LIMITED ACCESS HIGHWAYS: The work zone shall not be signed for the entire length of the mainline of a limited access highway when only short individual worksites, interchange or ramp work is being performed.

When work is restricted to ramp reconstruction or widening activities, the advance warning signs on the mainline section of the limited access highway shall be limited to the use of portable advance warning signs. These portable advance warning signs shall only be utilized when work activity is within the gore point of the ramp and the mainline traveled way or work is active in the acceleration/deceleration lane adjacent to the mainline traveled way. Portable advance warning signs (W20-1; 1500 ft./1000 ft./500ft.) shall be installed on the traveled way of the limited access highway when the above conditions are present. The advance warning signs shall be installed only in one direction where work is active. All portable signs shall be double indicated. When work is not active, the ramp work shall be advanced warned by the use of a single 48 inch X 48 inch "RAMP WORK AHEAD" sign along the right shoulder of the mainline traveled way prior to the beginning of the taper for the deceleration lane. The "RAMP WORK AHEAD" sign shall be mounted at seven (7') feet in height. Differences in elevation shall be in compliance with the requirements of Subsection 150.06 prior to the removal of the portable (W20-1) advanced warning signs from the mainline.

The G20-1 sign shall be eliminated on limited access highways when the work involves only ramp work, bridge reconstruction, bridge painting, bridge joint repairs, guardrail and anchor replacement or other site specific work which is confined to a short section of limited access highway.

I. Portable changeable message sign

Unless specified as a paid item in the contract the use of a portable changeable message sign will not be required. When specified, a portable changeable message sign (PCMS) shall meet the minimum requirements of Section 632 and the MUTCD. The maximum amount of messages allowed to be flashed on one PCMS is two phases (flashes). The language and the timing of the messages shall comply with the MUTCD and Section 632.

When used as an advanced device the PCMS should typically be placed ahead of the construction activities. If the PCMS is used as a substitute for another device then the requirements for the other device apply.

J. Flashing Beacon

The flashing beacon assembly, when specified, shall be used in conjunction with construction warning signs, regulatory, or guide signs to inform traffic of special road conditions which require additional driver attention. The flashing beacon assembly shall be installed in accordance with the requirements of Section 647.

K. Rumble strip signage

Signage for rumble strips located in the travel way shall be as required in Subsection 150.01.C and Subsection 150.02.A.9.

L. Low/soft shoulder signage

Low or soft shoulder signs shall be utilized in accordance with the following conditions:

CONSTRUCTION/RECONSTRUCTION PROJECTS:

“LOW/SOFT SHOULDER” signs shall be erected when a difference in elevation exceeds one (1”) inch but does not exceed three (3”) inches between the travel way and any type of shoulder unless the difference in elevation is four (4’) feet or greater from the edge of the traveled way.

The spacing of the signs shall not exceed one (1) mile and the signs shall be placed immediately past each crossroad intersection. The “Low/Soft” signs shall remain in place until the difference in elevation is eliminated and the shoulder has been dressed and permanently grassed for a minimum of thirty (30) calendar days. These signs shall be furnished, installed, maintained and removed by the Contractor as part of Traffic Control-Lump Sum. These signs shall be orange with black borders and meet the reflectorization requirements of Subsection 150.01.C.

“SHOULDER DROP-OFF” (W8-9a) signs shall be used when a difference in elevation, less than four (4’) feet from the traveled way, exceeds three (3”) inches and is not protected by positive barrier protection. These warning signs shall be placed in advance of the drop-off. For a continuous drop-off condition, the W8-9a) signs shall, as a minimum, be spaced in accordance with the above requirements for “Low/soft shoulder” signs.

PROJECTS CONSISTING PRIMARILY OF ASPHALTIC CONCRETE RESURFACING ITEMS:

“LOW/SOFT SHOULDER” signs shall be erected when a difference in elevation exceeds one (1”) inch but does not exceed three (3”) inches between the travel way and any type of shoulder unless the difference in elevation is four (4’) feet or greater from the edge of the traveled way.

SHOULDER BUILDING INCLUDED IN THE CONTRACT: “Low/Soft Shoulder” signs shall be erected as per the requirement of Standards 9102, 9106, and 9107. “Shoulder Drop-off” signs (W8-9a) shall be erected as per the requirements of the MUTCD. These signs shall be maintained until the conditions requiring their installation have been eliminated. The Contractor shall remove all interim warning signs before final acceptance.

SHOULDER BUILDING NOT INCLUDED IN THE CONTRACT: The County will furnish the “Low/Soft Shoulder” signs, “Shoulder Drop-off” signs and the posts. The signs shall be erected to meet the minimum requirements of Subsection 150.03. The Contractor shall include the cost of furnishing installation hardware (bolts, nuts, and washers), erection and maintenance of the signs in the bid price for Traffic Control- Lump Sum. The Contractor shall maintain the signs until final acceptance. The County will remove the signs.

LAU/LAR PROJECTS SHOULDER BUILDING NOT INCLUDED IN THE CONTRACT: The Contractor will furnish, install and maintain LOW/SOFT SHOULDER signs (yellow with black borders, ASTM Type III or IV) at the appropriate spacing, until Final Acceptance of the project by the County. After Final Acceptance by the County the signs will become the property and responsibility of the local government.

M. Bump signage

MULTI-LANE DIVIDED HIGHWAYS: A bump sign (W8-1) shall be utilized when a transverse joint in the pavement structure has a vertical difference in elevation of three quarters (3/4”) of an inch or greater in depth with no horizontal taper to ramp the traffic from one elevation to the other. This condition typically occurs at approach slabs during pavement milling operations and at transverse joints in asphaltic pavement lifts.

TWO-LANE TWO-WAY HIGHWAYS: A bump sign (W8-1) shall be utilized when a transverse joint in the pavement structure has a vertical difference in elevation that exceeds one and three quarters (1-

3/4") inches in depth with no horizontal taper to ramp the traffic from one elevation to the other. This includes utility and storm drainage repairs that require concrete placement for patching and/or steel plating.

The (W8-1) sign shall be placed sufficiently in advance to warn the motorist of the condition.

150.4 Pavement Markings

A. General

Full pattern pavement markings in accordance with Section 652 and in conformance with Section 3A and 3B, except 3B.02, of the MUTCD are required on all courses before the roadway is opened to traffic. No passing zones shall be marked to conform to Subsection 150.04.E. During construction and maintenance activities on all highways open to traffic, both existing markings and markings applied under this Section shall be fully maintained until Final Acceptance. If the pavement markings are, or become, unsatisfactory in the judgment of CIS Inc due to wear, weathering, or construction activities, they shall be restored immediately.

1. Resurfacing Projects

Pavement markings shall be provided on all surfaces that are placed over existing markings. Interim and final markings shall conform in type and location to the markings that existed prior to resurfacing unless changes or additions are noted in the Contract. The replacement of parking spaces will not be required unless a specific item or note has been included in the Contract. Any work to make additions to the markings that existed prior to resurfacing is to be considered as extra work.

2. Widening And Reconstruction Projects

If the lane configuration is altered from the preconstruction layout then pavement markings will be as required by the plans or CIS Inc.

3. New Location Construction Projects

Pavement marking plans will be provided.

B. Materials

All traffic striping applied under this Section shall be a minimum four inches in width or as shown in plans and shall conform to the requirements of Section 652, except as modified herein. Raised pavement markers (RPMs) shall meet the requirements of Section 654. Markings on the final surface course, which must be removed, shall be a removable type. The Contractor will be permitted to use paint, thermoplastic, or tape on pavement which is to be overlaid as part of the project, unless otherwise directed by CIS Inc. Partial (skip) reflectorization (i.e. reflectorizing only a portion of a stripe) will not be allowed.

C. Installation and removal of pavement markings

INSTALLATION: All pavement markings, both interim and permanent, shall be applied to a clean surface. The Contractor shall furnish the layout and preline the roadway surface for the placement of pavement markings applied as part of the traffic control plan. All interim marking tape and RPM's on the final surface shall be removed prior to the placement of the final markings.

The Contractor shall sequence the work in such a manner as to allow the installation of markings in the final lane configuration at the earliest possible stage of the work.

REMOVAL: Markings no longer applicable shall be removed in accordance with Subsection 656.2.

THE ELIMINATION OF CONFLICTING PAVEMENT MARKINGS BY OVERPAINTING WITH PAINT OR LIQUID ASPHALT IS NOT ACCEPTABLE.

INTERMEDIATE SURFACE: Interim markings shall be removed by methods that will cause minimal damage to the pavement surface while also ensuring that traveling public will not be confused or misdirected by any residual markings remaining on the intermediate surface. The use of approved black-out tape and black-out paint may be permitted on some interim surfaces, provided the results are satisfactory to CIS Inc.

FINAL SURFACE: No interim paint or thermoplastic markings will be permitted on any final surface unless the interim markings are in alignment with the location of the permanent markings and the interim marking will not interfere or adversely affect placement of the permanent markings. The proposed method of removal for layout errors that require markings to be removed from the final surface shall have the prior approval of CIS Inc. Any damage to the final pavement surface caused by the pavement marking removal process shall be repaired at the Contractor's expense by methods acceptable and approved by CIS Inc. Subsection 400.3.06.C shall apply when corrective measures are required. The use of black-out tape or black-out paint will not be permitted to correct layout errors on any final surface.

Traffic shifts that are done on the final surface shall be accomplished using interim traffic marking tape that can be removed without any blemishing of the final surface. Interim traffic marking tape shall be used on any of the following final surfaces; asphaltic concrete, Portland cement concrete, and bridge deck surfaces. Exceptions to the requirements for interim traffic marking tape shall have the written prior approval of CIS Inc before the application of any other method is permitted.

PAY FACTOR REDUCTION FOR ASPHALTIC CONCRETE FINAL SURFACES: When the correction of an error in the layout of the final pavement markings requires the final surface to be grounded, blemished, scarred, or polished the pay factor shall be reduced to 0.95 for the entire surface area of the final topping that has a blemish, polished or a scarred surface. The reduced pay factor shall not be confined to only the width and length of the stripe or the dimensions of the blemished areas, the whole roadway surface shall have the reduced pay factor applied. The area of the reduced pay factor shall be determined by the total length and the total width of the roadway affected. If the affected area is not corrected, the reduction in pay shall be deducted from the final payment for the topping layer of asphaltic concrete. CIS Inc shall make the final determination whether correction or a reduced pay factor is acceptable.

The eradication of pavement markings on intermediate and final concrete surfaces shall be accomplished by a method that does not grind, polish, or blemish the surface of the concrete. The method used for the removal of the interim markings shall not chip the joints in the concrete and shall not damage the sealant in the joints. Any joint or sealant repairs shall be included in the bid price for Traffic Control-Lump Sum. The proposed method of removal shall have the prior approval of CIS Inc.

Failure to promptly remove conflicting or non-applicable pavement markings shall be considered as non-performance under Subsection 150.08.

PREPARATION AND PLANNING FOR TRAFFIC SHIFTS: When shifting of traffic necessitates removal of centerline, lane lines, or edge lines, all such lines shall be removed prior to, during, or immediately after any change so as to present the least interference with traffic. Interim traffic marking tape shall be used as a temporary substitute for the traffic markings being removed.

Before any change in traffic lane(s) alignment, marking removal equipment shall be present on the project for immediate use. If marking removal equipment failures occur, the equipment shall be repaired or replaced (including leasing equipment if necessary), so that the removal can be accomplished without delay.

Except for the final surface, markings on asphaltic concrete may be obliterated by an overlay course, when approved by CIS Inc. When an asphaltic concrete overlay is placed for the sole purpose of

eliminating conflicting markings and the in place asphaltic concrete section will allow, said overlay will be eligible for payment only if designated in the Plans. Overlays to obliterate lines will be paid for only once and further traffic shifts in the same area shall be accomplished with removable markings. Only the minimum asphaltic concrete thickness required to cover lines will be allowed. Excessive build-up will not be permitted. When an overlay for the sole purpose of eliminating conflicting markings is not allowed, the markings no longer applicable shall be removed in accordance with Subsection 656.2.

D. Raised pavement markers

Raised pavement markers (RPMs) are required as listed below for all asphaltic concrete pavements before the roadway is open to traffic. On the final surface, RPM's shall be placed according to the timeframes specified in Subsection 150.04 E. for full pattern pavement markings except Interstate Highways where RPM's shall be placed and/or maintained when the roadway is open to traffic. When Portland Cement Concrete is an intermediate or final surface and is open to traffic, one calendar day is allowed for cleaning and drying before the installation of RPMs is required.

Raised pavement markers are not allowed on the right edge lines under any situation.

1. Interstate Highways

Retro-reflective raised pavement markers (RPM's) shall be placed and/or maintained on intermediate pavement surfaces on all interstate highways that are open to traffic. This includes all resurfacing projects along with widening and reconstruction projects. The spacing and placement shall be as required for MULTI-LANE DIVIDED HIGHWAYS.

2. Multi-Lane Divided Highways

Retro-reflective raised pavement markers (RPMs) shall be placed and/or maintained on intermediate pavement surfaces on all multi-lane divided highways that are opened to traffic when these roadways are being widened or reconstructed. Two lane-two way roadways that are being widened to a multi-lane facility, whether divided or undivided, are included in this provision. Projects consisting primarily of asphalt resurfacing items or shoulder widening items are excluded from this requirement. The RPMs shall be placed as follows:

a. SUPPLEMENTING LANE LINES

80 foot center on skip lines with curvature less than three degrees. (Includes tangents)

40 foot centers on solid lines and all lines with curvature between three degrees and six degrees.

20 foot centers on curves over six degrees.

20 foot centers on lane transitions or shifts.

b. SUPPLEMENTING RAMP GORE LINES

20 foot centers, two each, placed side by side.

c. OTHER LINES

As shown on the plans or directed by CIS Inc.

3. Other Highways

On other highways under construction RPMs shall be used and/or maintained on intermediate pavement surfaces as follows:

a. SUPPLEMENTING LANE LINES AND SOLID LINES

40 foot centers except on lane shifts. (When required in the Plans or Contract.)

20 foot centers on lane shifts. (Required in all cases.)

b. SUPPLEMENTING DOUBLE SOLID LINES

40 foot centers (one each beside each line) except on lane shifts. (When required in the Plans or Contract.)

20 foot centers on lane shifts. (Required in all cases.)

E. Exceptions for interim markings

Some exceptions to the time of placement and pattern of markings are permitted as noted below, however, full pattern pavement markings are required for the completed project.

1. **Two-Lane, Two-Way Roadways**

a. SKIP LINES

All interim skip (broken) stripe shall conform to Section 652 except that stripes shall be at least two feet long with a maximum gap of 38 feet. On curves greater than six degrees, a one-foot stripe with a maximum gap of 19 feet shall be used. In lane shift areas solid lines will be required. Interim skip lines shall be replaced with markings in full compliance with Section 652 prior to expiration of the 14 calendar day period.

Interim raised pavement markers may be substituted for the interim skip (broken) stripes. If raised pavement markers are substituted for the two foot interim skip stripe, three markers spaced at equal intervals over a two foot distance will be required. No separate payment will be made if the interim raised pavement markers are substituted for interim skip lines.

Interim raised pavement markers shall be retro-reflective, shall be the same color as the pavement markers for which they are substituted, and shall be visible during daytime.

The type of interim marker and method of attachment to the pavement shall be approved by the Office of Materials and Research but in no case will the markers be attached by the use of nails. Flexible reflective markers, Type 14 or Type 15, may be used for a maximum of fourteen (14) calendar days as an interim marker. Any flexible reflective markers in use shall be from the qualified products list (QPL).

The interim raised pavement markers shall be maintained until the full pattern pavement markings are applied. At the time full pattern markings are applied the interim raised markers shall be removed in a manner that will not interfere with application of the full pattern pavement markings.

b. NO PASSING ZONES-TWO-LANE, TWO-WAY ROADWAYS

Passing zones shall be re-established in the locations existing prior to resurfacing. No changes to the location of passing zones shall be done without the written approval of CIS Inc. For periods not to exceed three calendar days where interim skip centerlines are in place, no-passing zones shall be identified by using post or portable mounted DO NOT PASS regulatory signs (R4-1 24" x 30") at the beginning and at intervals not to exceed ½ mile within each no-passing zone. A post or portable mounted PASS WITH CARE regulatory sign (R4-1 24" x 30") shall be placed at the end of each no-passing zone. Post mounted signs shall be placed in accordance with the MUTCD. Portable signs shall conform to the requirements of the MUTCD and shall be NCHRP 350 compliant. Portable signs shall be secured in such a

manner to prevent misalignment and minimize the possibility of being blown over by weather conditions or traffic.

On new location projects and on projects where either horizontal or vertical alignments has been modified, the location of No-Passing Zones will be identified by CIS Inc.

- c. EDGELINES
 - 1) Bituminous Surface Treatment Paving
Edge lines will not be required on intermediate surfaces (including asphaltic concrete leveling for bituminous surface treatment paving) that are in use for a period of less than 60 calendar days except at bridge approaches, on lane transitions, lane shifts, and in such other areas as determined by CIS Inc. On the final surface, edge lines shall be placed within 30 calendar days of the time that the final surface was placed.
 - 2) All Other Types of Pavement
Edge lines will not be required on intermediate surfaces that are in use for a period of less than 30 calendar days except at bridge approaches, on lane transitions, lane shifts, and in such other areas as determined by CIS Inc. On the final surface, edge lines shall be placed within 14 calendar days of the time that the surface was placed.
- 2. **Multi-Lane Highways – With No Paved Shoulder(S) Or Paved Shoulder(S) Four Feet Or Less**
 - a. UNDIVIDED HIGHWAYS (INCLUDES PAVED CENTER TURN LANE)
 - 1) Centerlines and No-Passing Barrier-Full Pattern centerlines and no-passing barriers shall be restored before opening to traffic.
 - 2) Landlines- Interim skip (broken) stripe as described in Subsection 150.04E.1.a. may be used for periods not to exceed three calendar days. Skip lines are not permitted in lane shift areas. Solid lines shall be used.
 - 3) Edge lines- Edge lines shall be placed on intermediate and final surfaces within three calendar days of obliteration.
 - b. DIVIDED HIGHWAYS (GRASS OR RAISED MEDIAN)
 - 1) Landlines- Full pattern skip stripe shall be restored before opening to traffic. Skip lines are not permitted in lane shift areas. Solid lines shall be required.
 - 2) Centerline/Edge line- Solid lines shall be placed on intermediate and final surfaces within three calendar days of obliteration.
- 3. **Limited Access Roadways And Roadways With Paved Shoulders Greater Than Four Feet**
 - a. Same as Subsection 150.04.E.2 except as noted in (b) below.
 - b. EDGELINES-
 - 1) Asphaltic Concrete Pavement- Edge lines shall be placed on intermediate and final surfaces prior to opening to traffic.
 - 2) Portland Cement Concrete Pavement- Edge lines shall be placed on any surface open to traffic no later than one calendar day after work is completed on a section of roadway. All water and residue shall be removed prior to daily striping.

4. **Ramps For Multi-Lane Divided Highways**

A minimum of one solid line edge stripe shall be placed on any intermediate surface of a ramp prior to opening the ramp to traffic. The other edge stripe may be omitted for a maximum period of three (3) calendar days on an intermediate surface.

Appropriate channelization devices shall be spaced at a maximum of twenty-five (25') feet intervals until the other stripe has been installed.

The final surface shall have both stripes placed prior to opening the ramp to traffic.

5. **Miscellaneous pavement markings**

FINAL SURFACE: School zones, railroads, stop bars, symbols, words and other similar markings shall be placed on final surfaces conforming to Section 652 within fourteen (14) calendar days of completion of the final surface. Final markings shall conform to the type of pay item in the plans. When no pay item exists in the plans the final markings shall conform to Section 652 for painted markings.

INTERMEDIATE SURFACE: Intermediate surfaces that will be in use for more than forty-five (45) calendar days shall have the miscellaneous pavement markings installed to conform to the requirement of Section 652. Under Subsection 150.11, Special Conditions, or as directed by CIS Inc these markings may be eliminated.

F. Mobile operations

When pavement markings (centerlines, lane lines, and edge lines) are applied in a continuous operation by moving vehicles and equipment, the following minimum equipment and warning devices shall be required. These devices and equipment are in addition to the minimum requirements of the MUTCD.

1. **All Roadways**

All vehicles shall be equipped with the official slow moving vehicle symbol sign. All vehicles shall have a minimum of two flashing or rotating beacons visible in all directions. All protection vehicles shall have an arrow panel mounted on the rear. All vehicles requiring an arrow panel shall have, as a minimum, a Type B panel. All vehicle mounted signs shall be mounted with the bottom of the sign a minimum height of forty-eight inches (48") above the pavement. All sign legends shall be covered or removed from view when work is not in progress.

2. **Two-Lane Two-Way Roadways**

a. **Lead Vehicles**

The lead vehicle may be a separate vehicle or the work vehicle applying the pavement markings may be used as the lead vehicle. The lead vehicle shall have an arrow panel mounted so that the panel is easily visible to oncoming (approaching) traffic. The arrow panel should typically operate in the caution mode.

b. **Work Vehicles**

The work vehicle(s) applying markings shall have an arrow panel mounted on the rear. The arrow panel should typically operate in the caution mode. The work vehicle placing cones shall follow directly behind the work vehicle applying the markings.

c. **Protection Vehicles**

A protection vehicle may follow the cone work vehicle when the cones are being placed and may follow when the cones are being removed.

3. **Multi-Lane roadways**

A lead vehicle may be used but is not required. The work vehicle placing cones shall follow directly behind the work vehicle applying the markings. A protection vehicle that does not function as a work vehicle should follow the cone work vehicle when traffic cones are being placed. A protection vehicle should follow the cone work vehicle when the cones are being

removed from the roadway. Protection vehicles shall display a sign on the rear of the vehicle with the legend PASS ON LEFT(RIGHT).

INTERSTATES AND LIMITED ACCESS ROADWAYS: A protection vehicle shall follow the last work vehicle at all times and shall be equipped with a truck mounted attenuator (TMA) that is certified for impacts not less than 62 mph in accordance with NCHRP350 Test Level Three (3).

150.5 Channelization

A. General

Channelization shall clearly delineate the travel way through the work zone and alert drivers and pedestrians to conditions created by work activities in or near the travel way. Channelization shall be done in accordance with the plans and specifications, the MUTCD, and the following requirements.

All Channelization Devices utilized on any project shall be NCHRP 350 compliant. Any device used on the Work shall be from the Qualified Products List. All devices utilized on the work shall have a decal, logo, or manufacturer’s stamping that clearly identifies the device as NCHRP 350 compliant. The Contractor may be required to furnish certification from the Manufacturer for any device to prove NCHRP 350 compliance.

1. Types of Devices Permitted for Channelization in Construction Work Zones:

a. DRUMS:

- 1) **DESIGN:** Drums shall meet the minimum requirement of the MUTCD and shall be reflectorized as required in Subsection 150.01.C. The upper edge of the top reflectorized stripe on the drum shall be located a minimum of 33 inches above the surface of the roadway. A minimum drum diameter of 18 inches shall be maintained for a minimum of 34 inches above the roadway.
- 2) **APPLICATION:** Drums shall be used as the required channelizing device to delineate the full length of a lane closure, shift, or encroachment, except as modified by this Subsection.
- 3) **TRANSITION TAPERS FOR LANE CLOSURES:** Drums shall be used on all transition tapers. The minimum length for a merging taper for a lane closure on the travel way shall be as shown in Table 150-1:

TABLE 150-1

| Posted Speed Limit, MPH | Lane Width 9 Feet | Lane Width 10 Feet | Lane Width 11 Feet | Lane Width 12 Feet | Maximum Drum Spacing in Tapers, (Feet) |
|-------------------------|----------------------------------|--------------------|--------------------|--------------------|--|
| | Minimum Taper Length (L) in Feet | | | | |
| 20 | 60 | 70 | 75 | 80 | 20 |
| 25 | 95 | 105 | 115 | 125 | 25 |
| 30 | 135 | 150 | 165 | 180 | 30 |
| 35 | 185 | 205 | 225 | 245 | 35 |
| 40 | 240 | 270 | 295 | 320 | 40 |
| 45 | 405 | 450 | 495 | 540 | 45 |
| 50 | 450 | 500 | 550 | 600 | 50 |
| 55 | 495 | 550 | 605 | 660 | 55 |
| 60 | 540 | 600 | 660 | 720 | 60 |
| 65 | 585 | 650 | 715 | 780 | 65 |
| 70 | 630 | 700 | 770 | 840 | 70 |
| 75 | 675 | 750 | 825 | 900 | 75 |

If site conditions require a longer taper then the taper shall be lengthened to fit particular individual situations.

The length of shifting tapers should be at least $\frac{1}{2}$ L.

The length of a closed lane or lanes, excluding the transition taper(s), shall be limited to a total of two (2) miles. Prior approval must be obtained from CIS Inc before this length can be increased.

Night time conditions: When a merge taper exists into the night all drums located in the taper shall have, for the length of the taper only, a six (6") inch fluorescent orange (ASTM Type VII, VIII, IX or X) reflectorized top stripe on each drum. The top six-inch stripe may be temporarily attached to the drum while in use in a taper. All drums that have the six-inch top stripe permanently attached shall not be used for any other conditions.

Multiple Lane Closures:

- (a) A maximum of one lane at a time shall be closed with each merge taper.
- (b) A minimum tangent length of 2 L shall be installed between each individual lane closure taper.

- 4) LONGITUDINAL CHANNELIZATION: Drums shall be spaced as listed below for various roadside work conditions except as modified by Subsection 150.06. Spacing shall be used for situations meeting any of the conditions listed as follows:
 - (a) 40 FOOT SPACING MAXIMUM
 - (1) For difference in elevation exceeding two inches.
 - (2) For heeled sections no steeper than 4:1 as shown in Subsection 150.06, Detail 150-E.
 - (b) 80 FOOT SPACING MAXIMUM
 - (1) For difference in elevation of two inches or less.
 - (2) Flush areas where equipment or workers are within ten feet of the travel lane.
 - (c) 200 FOOT SPACING MAXIMUM: Where equipment or workers are more than ten feet from travel lane. Lateral offset clearance to be four feet from the travel lane.
 - (1) For paved areas eight feet or greater in width that are paved flush with a standard width travel lane.
 - (2) For disturbed shoulder areas not completed to typical section that are flush to the travel lane and considered a usable shoulder.

REMOVAL OF DRUMS: Drums may be removed after shoulders are completed to typical section and grassed. Guardrail and other safety devices shall be installed and appropriate signs advising of conditions such as soft or low shoulder shall be posted before the drums are removed.

b. VERTICAL PANELS

- 1) DESGN: All vertical panels shall meet the minimum requirements of the MUTCD. All vertical panels shall have a minimum of 270 square inches of retro-reflective area facing the traffic and shall be mounted with the top of the reflective panel a minimum of 36" above the roadway.
- 2) APPLICATION: Lane encroachment by the drum on the travel way should permit a remaining lane width of ten feet. When encroachment reduces the travel way to less than ten feet, vertical panels shall be used to restore the travel way to ten feet or greater. No other application of vertical panels will be permitted.

c. CONES

- 1) DESIGN: All cones shall be a minimum of 28 inches in height regardless of application and shall meet the requirement of the MUTCD. Reflectorization may be deleted from all cones.
- 2) APPLICATION: For longitudinal channelizing only, cones will be permitted for daylight closures or minor shifts. (Drums are required for all tapers.) The use of cones for nighttime work will not be permitted. Cones shall not be stored or allowed to be visible on the worksite during nighttime hours.

d. BARRICADES

DESIGN: Type III barricades shall meet the minimum requirements of the MUTCD and shall be reflectorized as required in Subsection 150.01.C.

The Contractor has the option of choosing Type III barricades from the Qualified Products List or the Contractor may utilize generic barricades that are approved by the Federal Highway Administration (FHWA). When barricades have been specifically crash tested with signs attached, the contractor has the responsibility to attach the signs as per the manufacturer's recommendations to ensure crashworthiness. If signs are attached to generic barricades or to barricades from the Qualified Products List (QPL) that have not been crash tested with signs attached then the responsibility for crashworthiness and the liability for mounting these signs to the barricades are assumed by the Contractor and the Contractor shall certify that the barricades are crashworthy under FHWA work zone guidelines for NCHRP 350 crashworthy compliance. Any generic barricades used in the work shall be stamped or stenciled to show compliance with NCHRP 350. The use of Type I and Type II barricades will not be permitted.

- 1) APPLICATION: Type III barricades shall be placed as required by the plans, the Standards, and as directed by CIS Inc. All signs mounted on barricades shall be mounted to comply with the requirements of the MUTCD and NCHRP 350 Test Level III. NCHRP 350 crashworthy compliance may require that rigid signs be mounted separate from the Type III barricade.

When a barricade is placed so that it is subject to side impact from a vehicle, a drum shall be placed at the side of the barricade to add target value to the barricade.

e. WARNING LIGHTS:

- 1) DESIGN: All warning lights shall meet the requirements of the MUTCD.
- 2) APPLICATION
 - (a) Type A low-intensity flashing lights shall be used as shown in the Plans, the Standards, and as directed by CIS Inc. Flashing lights are not required for advance warning signs in Subsection 150.03.H.
 - (b) Type C Steady-Burn lights shall be used as shown in the Plans, the Standards, and as directed by CIS Inc. Steady-burn lights are not required on drums for merging tapers that exist into the night.

f. TEMPORARY BARRIERS

- 1) DESIGN: Temporary barriers shall meet the requirements of Sections 620.
- 2) APPLICATION: Temporary barriers shall be placed as required by the plans, standards, and as directed by CIS Inc. When Temporary barrier is located 20 feet or less from a travel lane, yellow reflectors shall be fixed to the top of the barrier at intervals not greater than 40 feet in the longitudinal section and 20 feet in the taper section and shall be

mounted approximately two inches above the barrier. If both lanes of a two-lane two-way roadway are within 20 feet or less of the barrier then the reflectors shall be installed for both directions of traffic.

The reflectors shall be 100 square inches (ASTM Type VII or VIII) reflective sheeting mounted on flat-sheet blanks. The reflectors shall be mounted approximately two inches above the top of the barrier. The reflectors shall be attached to the barrier with adhesive or by a drilled-in anchor type device. The reflectors shall not be attached to a post or board that is placed between the gap in the barrier sections.

Approach end of Temporary barrier shall be flared or protected by an impact attenuator (crash cushion) or other approved treatment in accordance with Georgia Standard 4960, Construction Details and Standard Specifications.

On interstate or other controlled access highways where lane shifts or crossovers cause opposing traffic to be separated by less than 40 ft., portable barrier shall be used as a separator.

B. Portable impact attenuators

1. Description

This work consists of the furnishing (including spare parts), installation, maintenance, relocation, reuse as required, and removal of Portable Impact Attenuator Unit/Arrays.

2. Materials

Materials used in the Attenuator/Array shall meet the requirements of Section 648 for Portable Impact Attenuators.

3. Construction

Portable Impact Attenuator Unit/Array installation shall conform to the requirements of Section 648, Manufacturer's recommendations, and/or Georgia Standards 4960 & 4962 and shall be installed at locations designated by CIS Inc, and/or as shown on the plans.

C. Temporary guardrail anchorage –Type 12

1. Description

This work consists of the furnishing, installation, maintenance and removal of Temporary Guardrail Anchorage- Type 12 used for Portable Barrier or temporary guardrail end treatment.

2. Materials

Materials used in the Temporary Guardrail Anchorage- Type 12 shall meet the requirements of Subsection 641.2 of the Specifications and current Georgia Standards and may be new or used. Materials salvaged from the Project which meet the requirements of Standards may be utilized if available. The use of any salvaged materials will require prior approval of CIS Inc.

3. Construction

Installation of the Temporary Guardrail Anchorage- Type 12 shall conform to the requirements of the Plans, current Georgia Standards and Subsection 641.3 of the Specifications. Installation shall also include sufficient additional guardrail and appurtenances to effect the transition and connection to Temporary Concrete Barrier as required by the details in Georgia Standard 4960.

150.6 Differences in elevation between travel lanes and shoulders (See Subsection 150.06G for projects consisting primarily of asphaltic concrete resurfacing items)

Any type of work such as paving, grinding, trenching, or excavation that creates a difference in elevation between travel lanes or between the travel way and the shoulder shall not begin until the Contractor is

prepared and able to continuously place the required typical section to within two inches (2") of the existing pavement elevation. For any areas that the two inches minimum difference in elevation cannot be accomplished the section shall be healed as shown in Detail 150-E. If crushed stone materials are used to provide a healed section no separate payment will be made for the material used to heal any section. The Contractor may submit a plan to utilize existing pay items for crushed stone provided the plan clearly demonstrates that the materials used to heal an area will be incorporated into the work with minimal waste. Handling and hauling of any crushed stone used to heal shall be kept to a minimum. CIS Inc shall determine if the crushed stone used to heal meets the specifications for gradation and quality when the material is placed in the final location.

A maximum of sixty (60) calendar days shall be allowed for conditions to exist that require any section or segment of the roadway or ramp to continue to require a healed section as described by Detail 150-E. Failure to meet this requirement shall be considered as non-performance of Work under Subsection 150.08.

When trenching or excavation for minor roadway or shoulder widening is required, all operations at one site shall be completed to the level of the existing pavement in the same work day.

Any channelization devices utilized in the work shall conform to the requirements of Subsection 150.05 and to the placement and spacing requirements in Details 150-B, 150-C, 150-D, and 150-E shown in this section.

Any construction activity that reduces the width of a travel lane shall require the use of a W-20 sign with the legend "LEFT/RIGHT LANE NARROWS". Two 24" x 24" red or red/orange flags may be mounted above the W-20 sign. The W-20 sign shall be located on the side of the travel way that has been reduced in width just off the travel way edge of pavement. The W-20 sign shall be a minimum of 500 feet in advance of any channelization devices that encroach on the surface of travel way. A portable changeable message sign may be used in lieu of the W-20 sign.

General/time restrictions

A. Stone Bases, Soil Aggregate Base and Soil Bases

1. All Highways

Differences in elevation of more than two inches between surfaces carrying or adjacent to traffic will not be allowed for more than a 24-hour period. A single length of excavated area that does not exceed 1000 feet in total length may be left open as a start up area for periods not to exceed 48 hours provided the Contractor can demonstrate the ability to continuously excavate and backfill in a proficient manner. Prior approval of CIS Inc shall be obtained before any startup area may be allowed.

2. Limited Access Highway Ramps (Interstates)

On projects that include ramp rehabilitation work, one ramp at a time may be excavated for the entire length of the ramp from the gore point of the ramp with the interstate mainline to the intersection with the crossing highway. This single ramp may remain excavated with a vertical difference in elevation greater than two (2") inches for a maximum of fourteen (14) calendar days with drums spaced at twenty (20') feet intervals as shown in Detail 150-B and a buffer space accepted under Section 150.06.F. After fourteen (14) calendar days the section shall be healed as required for all other highways. This area will be allowed in addition to the 1000 feet allowed for all other highways.

B. Asphalt Bases, Binders and Toppings

1. Differences in elevation between the surfaces of adjacent

Travel lanes shall be paved with a plan that minimizes any difference in elevation between adjacent travel lanes. The following limitations will be required on all work:

- a. Differences of two inches (2") or less may remain for a maximum period of fourteen (14) calendar days.
- b. Differences of greater than two inches (2") shall be permitted for continuous operations only.

EMERGENCY SITUATIONS: Inclement weather, traffic accidents, and other events beyond the control of the Contractor may prevent the work from being completed as required above. The Contractor shall notify CIS Inc in writing stating the conditions and reasons that have prevented the Contractor from complying with the time limitations. The Contractor shall also outline a plan detailing immediate steps to complete the work. Failure to correct these conditions on the first calendar day that conditions will allow corrective work shall be considered as non-performance of Work under Subsection 150.08.

2. **Differences in elevation between asphalt travel way and paved**

Differences in elevation between the asphalt travel way and asphalt paved shoulders shall not be allowed to exist beyond the maximum durations outlined below for the conditions shown in Details 150-B, 150-C, 150-D, and 150-E:

Detail 150-B conditions shall not be allowed for more than 24 hours. A single length that does not exceed 1000 feet in total length may be left open for periods not to exceed 48 hours provided the Contractor can demonstrate the ability to continuously pave in a proficient manner. Prior approval of CIS Inc shall be obtained before any section is allowed to exceed 24 hours. Any other disturbed shoulder areas shall be healed as in Detail 150-E.

Detail 150-C conditions will not be allowed for more than 48 hours.

Detail 150-D conditions will not be allowed for more than 30 calendar days.

Detail 150-E conditions will not be allowed for more than 60 calendar days.

Failure to meet these requirements shall be considered as non-performance of Work under Subsection 150.08.

C. **Portland Cement concrete**

Work adjacent to a Portland Cement Concrete traveled way which involves the following types of base and shoulders shall be accomplished according to the time restrictions outlined for each type of base or shoulder. Traffic control devices shall be in accordance with Subsection 150.05.

1. **Cement stabilized base**

Work adjacent to the traveled way shall be healed as per Detail 150-E within forty-eight (48) hours after the seven (7) calendar day curing period is complete for each section placed. During the placement and curing period, traffic control shall be in accordance Detail 150-B.

2. **Asphaltic concrete base**

When an asphaltic concrete base is utilized in lieu of a cement stabilized base the asphaltic concrete base shall be healed as per Detail 150-E within forty-eight (48) hours after the placement of each section of asphaltic concrete base. For the first forty eight hours traffic control shall be in compliance with Detail 150-B.

3. **Concrete paved shoulders**

Concrete paved shoulders shall be placed within sixty (60) calendar days after the removal of each section of existing shoulder regardless of the type of base materials being placed on the shoulders. During the placement period, traffic control devices shall be in accordance with the appropriate detail based on the depth of the change in elevation.

4. **Asphaltic concrete shoulders**

A difference in elevation that meets the requirements of Detail 150-B shall not be allowed to exist for a period greater than forty-eight (48) hours. After the removal of the existing shoulder the section or segment of travel way may be healed with stone as per Detail 150-E for a maximum of fourteen (14) calendar days. Asphaltic concrete shoulders shall be placed within two (2") inches or less of the traveled way surface within fourteen (14) calendar days after the removal of the stone healed section or the removal of each section of the existing shoulder. The two (2") inches or less difference in elevation shall not remain in existence for a period that exceeds thirty (30) calendar days unless the paved shoulder is utilized as a detour for the traveled way. During the placement period, traffic control shall be in accordance with the appropriate detail based on the depth of the change in elevation.

The Contractor may propose an alternate plan based on Subsection 150.06.F. Failure to meet the above requirements and time restrictions shall be considered as non-performance of Work under Subsection 150.08.

D. Miscellaneous elevation differentials for excavations adjacent to the travel way

Drainage structures, utility facilities, or any other work which results in a difference in elevation adjacent to the travel way shall be planned and coordinated to be performed in such a manner to minimize the time traffic is exposed to this condition. The excavation should be back filled to the minimum requirements of Detail 150-E as soon as practical. Stage construction such as plating or backfilling the incomplete work may be required. The difference in elevation shall not be allowed to exist for more than five (5) calendar days under any circumstances. Failure to correct this condition shall be considered as non-performance of Work under Subsection 150.08.

E. Conduit Installation in paved and dirt shoulders

The installation of conduit and conduit systems along the shoulders of a traveled way shall be planned and installed in a manner to minimize the length of time that traffic is exposed to a difference in elevation condition. The following restrictions and limitations shall apply:

1. Differences in elevation of Two (2") Inches or less

The shoulder may remain open when workers are not present. When workers are present the shoulder shall be closed and the channelization devices shall meet the requirements of Subsection 150.05. The difference in elevation on the shoulder shall remain for a maximum period of fourteen (14) calendar days.

2. Differences in elevation greater than Two (2") Inches

The shoulder shall be closed. The shoulder closure shall not exceed twenty-four (24) hours in duration unless the Special Conditions in Subsection 150.11 modifies this restriction or CIS Inc allows the work to be considered as a continuous operation.

Failure to meet these requirements shall be considered as non-performance of Work under Subsection 150.08.

F. Modifications to Details 150-B, 150-C, 150-D AND 150-E

The Contractor may propose any alternate traffic control plan that utilizes a portion of the travel lane as a "buffer space". This buffer space may allow for an enhanced work area that will allow for the placement of materials to proceed at a pace that could not be achieved with the time restriction requirements outlined in Section 150.06.A, 150.06.B, and 150.06.C. The Contractor may propose modified time restrictions based on the use of the buffer space. Any proposed modifications in the time duration allowed for the differences in elevations to exist shall be reviewed by CIS Inc as a component of the overall traffic control plan. No modifications shall be made until the proposed plan

is accepted by CIS Inc. CIS Inc shall have no obligation to consider any proposal which results in an increase in cost to the County.

For the travel lane described in each of the details 150-B, 150-C, 150-D and 150-E it is presumed that the pavement marking edge line (yellow or white solid stripe) is located at the very edge of the travel lane surface. A buffer space (temporary paved shoulder) that utilizes a portion of the travel lane should be six (6') feet in width desirable but shall not be less than four (4') feet in width. Any remaining travel lane(s) shall not be less than ten (10') feet in width.

If the proposed shifting of the traffic to obtain a buffer space and maintain a minimum travel lane(s) of ten (10') feet requires the use of any existing paved shoulders then the cost of maintenance and repair of the existing paved shoulder(s) shall be the responsibility of the Contractor. The Contractor is responsible for the costs of maintenance and repairs even if the existing paved shoulder(s) is to be removed in a later stage of the work. Existing shoulders that have rumble strips shall have the rumble strips removed before the shoulder can be utilized as part of the travel lane. The cost of the removal of the rumble strips shall be done at no cost to the County even if the shoulder is to be removed in a later stage of the work.

Any modifications to the staging and time restrictions that are approved as part of the traffic control plan shall be agreed to in writing. Failure to meet these modifications shall be considered as non-performance of the Work under Subsection 150.08.

G. Asphaltic Concrete Resurfacing Projects

SHOULDER CONSTRUCTION INCLUDED AS A PART OF THE CONTRACT: When the placement of asphaltic concrete materials creates a difference in elevation greater than two (2") inches between the earth shoulder (grassed or un-grassed) and the edge of travel way or between the earth shoulder and a paved shoulder that is less than four (4') feet in width, the Contractor shall place and maintain drums in accordance with the requirements of Subsection 150.05A.1.a.4). When the edge of the paved surface is tapered with a 30-45 degree wedge, drums may be spaced at 2.0 times the speed limit in MPH. Drums shall remain in place and be maintained until the difference in elevation has been eliminated by the placement of the appropriate shoulder materials.

SHOULDER CONSTRUCTION NOT INCLUDED AS A PART OF THE CONTRACT: When the placement of asphaltic concrete materials creates a difference in elevation greater than two (2") inches between the earth shoulder (grassed or un-grassed) and the edge of travel way or between the earth shoulder and a paved shoulder that is less than four (4') feet in width, the Contractor shall notify CIS Inc, in writing, when the resurfacing work including all punch list items has been completed. See Subsection 150.03.L for the requirements for "LOW/SOFT SHOULDERS" and "SHOULDER DROP-OFF" signage.

Location of drums when Elevation Difference exceeds 4 inches. Drums spaced at 20 foot intervals.
Note: If the travel way width is reduced to less than 10 feet by the use of drums, vertical panels shall be used in lieu of drums.

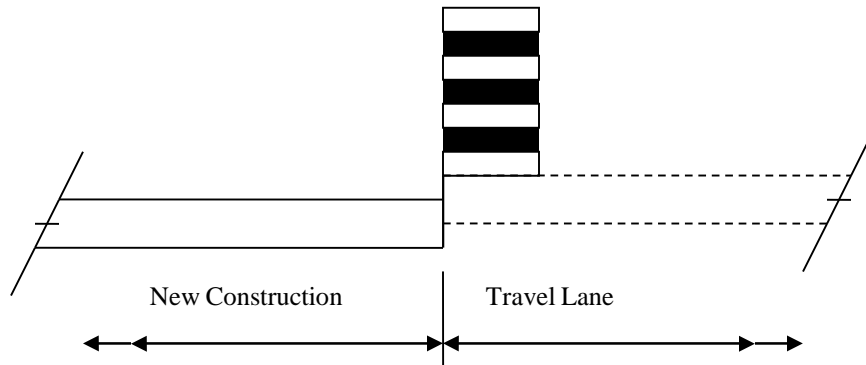

**ELEVATION DIFFERENCE GREATER THAN 4 INCHES
DETAIL 150-B**

| | |
|------------------------------------|---|
| Drums spaced at 40 foot intervals. | Location of drums when Elevation Difference is 2+ inches to 4 inches. |
|------------------------------------|---|

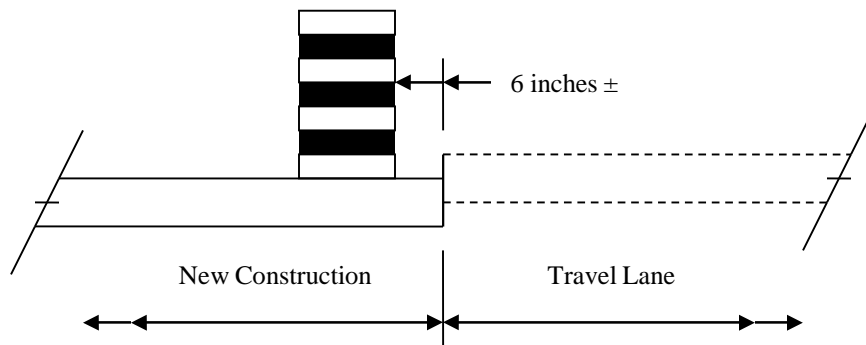

**ELEVATION DIFFERENCE 2+ TO 4 INCHES
DETAIL 150-C**

| | |
|------------------------------------|--|
| Drums spaced at 80 foot intervals. | Location of drums when Elevation Difference is 2 inches or less. |
|------------------------------------|--|

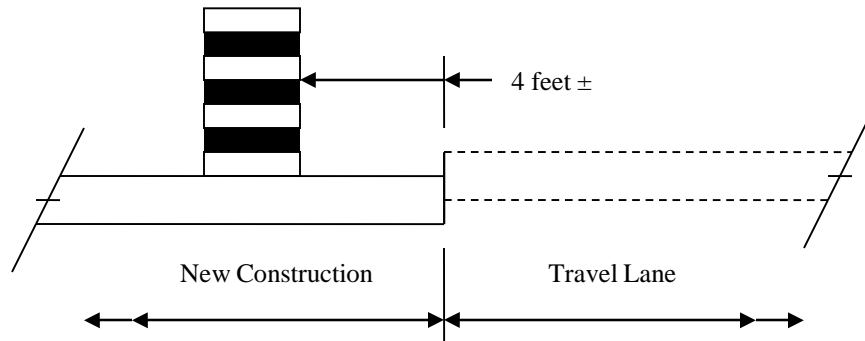

ELEVATION DIFFERENCE OF 2 INCHES OR LESS
DETAIL 150-D

| | |
|--|--|
| | Location of drums immediately after completion of healed sections spaced at 40 foot intervals. |
|--|--|

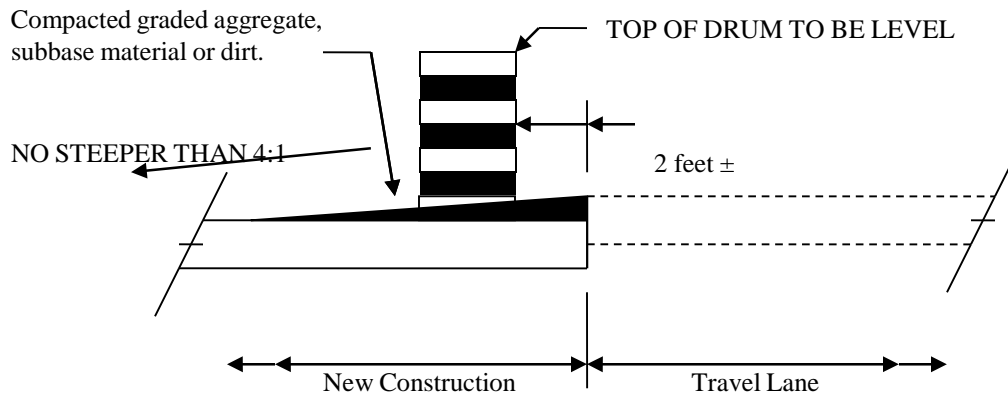

HEALED SECTION
DETAIL 150-E

150.7 Flagging and Pilot cars

A. Flaggers

Flaggers shall be provided as required to handle traffic, as specified in the Plans or Special Provisions, and as required by CIS Inc.

B. Flagger Certification

All flaggers shall meet the requirements of the MUTCD and shall have received training and a certificate upon completion of the training from a County approved training program. Failure to provide certified flaggers as required above shall be reason for CIS Inc suspending work involving

the flagger(s) until the Contractor provides the certified flagger(s). Flaggers shall have proof of certification and valid identification (photo I.D.) available any time they are performing flagger duties.

C. Flagger Appearance and equipment

Flaggers shall wear high-visibility clothing in compliance with the MUTCD and shall use a Stop/Slow paddle meeting the requirements of the MUTCD for controlling traffic. The Stop/Slow paddles shall have a shaft length of seven (7) feet minimum. The Stop/Slow paddle shall be retro-reflectORIZED for both day and night usage. In addition to the Stop/Slow paddle, a flagger may use a flag as an additional device to attract attention. This flag shall meet the minimum requirements of the MUTCD. The flag shall, as a minimum, be 24" inches square and red or red/orange in color. For night work, the vest shall have reflectORIZED stripes which meet the requirements of the MUTCD.

D. Flagger warning signs

Signs for flagger traffic control shall be placed in advance of the flagging operation in accordance with the MUTCD. In addition to the signs required by the MUTCD, signs at regular intervals, warning of the presence of the flagger shall be placed beyond the point where traffic can reasonably be expected to stop under the most severe conditions for that day's work.

E. Pilot vehicle requirements

Pilot vehicles will be required during placement of bituminous surface treatment or asphaltic concrete on two-lane roadways unless otherwise specified. Pilot vehicles shall meet the requirements of the MUTCD.

F. Portable temporary traffic control signals

The Contractor may request, in writing, the substitution of portable temporary traffic control signals for flaggers on two-lane two-way roadways provided the temporary signals meets the requirements of the MUTCD, Section 647, and Subsection 150.02.A.8. As a part of this request, the Contractor shall also submit an alternate traffic control plan in the event of a failure of the signals. Any alternate plan that requires the use of flaggers shall include the use of certified flaggers. The Contractor shall obtain the approval of CIS Inc before the use of any portable temporary traffic control signals will be permitted.

150.8 Enforcement

The safe passage of pedestrians and traffic through and around the temporary traffic control zone, while minimizing confusion and disruption to traffic flow, shall have priority over all other Contractor activities. Continued failure of the Contractor to comply with the requirements of Section 150 (TRAFFIC CONTROL) will result in non-refundable deductions of monies from the Contract as shown in this Subsection for non-performance of Work.

Failure of the Contractor to comply with this Specification shall be reason for CIS Inc suspending all other work on the Project, except erosion control and traffic control, taking corrective action as specified in Subsection 105.15, and/or withholding payment of monies due to the Contractor for any work on the Project until traffic control deficiencies are corrected. These other actions shall be in addition to the deductions for non-performance of traffic control.

| SCHEDULE OF DEDUCTIONS FOR EACH CALENDAR DAY OF DEFICIENCIES OF TRAFFIC CONTROL INSTALLATION AND/OR MAINTENANCE | | |
|---|------------------|--------------|
| ORIGINAL TOTAL CONTRACT AMOUNT | | |
| From More Than | To and Including | Daily Charge |
| \$0 | \$100,000 | \$200 |
| \$100,000 | \$1,000,000 | \$500 |
| \$1,000,000 | \$5,000,000 | \$1,000 |
| \$5,000,000 | \$20,000,000 | \$1,500 |
| \$20,000,000 | \$40,000,000 | \$2,000 |
| \$40,000,000 | \$----- | \$3,000 |

150.9 Measurement**A. Traffic Control**

When listed as a pay item in the Proposal, payment will be made at the Lump Sum price bid, which will include all traffic control not paid for separately, and will be paid as follows:

When the first Construction Report is submitted, a payment of 25 (twenty-five) percent of the Lump Sum price will be made. For each progress payment thereafter, the total of the Project percent complete shown on the last pay statement plus 25 (twenty-five) percent will be paid (less previous payments), not to exceed one hundred (100) percent.

When no payment item for Traffic Control-Lump Sum is shown in the Proposal, all of the requirements of Section 150 and the Traffic Control Plan shall be in full force and effect. The cost of complying with these requirements will not be paid for separately, but shall be included in the overall bid submittal.

B. Signs

When shown as a pay item in the contract, interim special guide signs will be paid for as listed below. All other regulatory, warning, and guide signs, as required by the Contract, will be paid for under Traffic Control Lump Sum or included in the overall bid submitted.

1. Interim ground mounted or interim overhead special guide signs will be measured for payment by the square foot. This payment shall be full compensation for furnishing the signs, including supports as required, erecting, illuminating overhead signs, maintaining, removing, re-erecting, and final removal from the Project. Payment will be made only one time regardless of the number of moves required.
2. Remove and reset existing special guide signs, ground mount or overhead, complete, in place, will be measured for payment per each. Payment will be made only one time regardless of the number of moves required.
3. Modify special guide signs, ground mount or overhead, will be measured for payment by the square foot. The area measured shall include only that portion of the sign modified. Payment shall include materials, removal from posts or supports when necessary, and remounting as required.

C. Temporary Barrier

Temporary Barrier shall be measured as specified in Section 620.

D. Changeable message sign, portable

Changeable Message Sign, Portable will be measured as specified in Section 632.

E. Temporary Guardrail anchorage, Type 12

Temporary Guardrail Anchorage- Type 12 will be measured by each assembly, complete in place and accepted according to the details shown in the plans, which shall also include the additional guardrail and appurtenances necessary for transition and connection to Temporary Concrete Barrier. Payment shall include all necessary materials, equipment, labor, site preparation, maintenance and removal.

F. Traffic signal installation – Temporary

Traffic Signal Installation- Temporary will be measured as specified in Section 647.

G. Flashing Beacon assembly

Flashing Beacon Assemblies will be measured as specified in Section 647.

H. Portable impact attenuators

Each Portable Impact Attenuator will be measured by the unit/array which shall include all material components, hardware, incidentals, labor, site preparation, and maintenance, including spare parts recommended by the manufacturer for repairing accident damage. Each unit will be measured only once regardless of the number of locations installed, moves required, or number of repairs necessary because of traffic damage. Upon completion of the project, the units shall be removed and retained by the Contractor.

I. Pavement Markings

Pavement markings will be measured as specified in Section 150.

150.10 Payment

When shown in the Schedule of Items in the Proposal, the following items will be paid for separately.

Item No. 150. Traffic Control.....Lump Sum

150.11 SPECIAL CONDITIONS:

A. The Contractor shall not perform work, close lanes, or move equipment or materials on any portions of the project from 7:00 PM Friday until 7AM Monday.

152 – FIELD LABORATORY BUILDING

152.1.02 Related References

Delete Subsection 152.1.02.B and replace with the following:

B. Referenced Documents

GDT 38

GDT 83

NFPA-10A

152.3.05 Construction

D. Asphaltic Concrete Plant Laboratory Requirements

Delete Subsections 102.3.05.D.5.e through h in their entirety.

SECTION 161 CONTROL OF SOIL EROSION AND SEDIMENTATION

Section 161.1 GENERAL DESCRIPTION:

Add the following:

"In addition to the above, this project is subject to the provisions of the National Pollutant Discharge Elimination System for Storm Water Discharge Associated with Construction Activity, General Permit Number GAR 100002 of the County of Natural Resources, Environmental Protection Division, State of Georgia.

The General Permit requires the following documents:

Notice of Intent (NOI) shall be submitted to the Environmental Protection Division. The NOI will be submitted by the County.

Contractor's Certification Statement is included in the Proposal. Execution of the Contract shall constitute execution of the Contractor's Certification.

Storm Water Pollution Prevention Plan (SWPPP) shall be kept on site and shall consist of the following:

1. Project Plans
2. Standard Plans including Standard Construction Details
3. Specifications
4. Contract Documents
5. Contractor's Erosion and Sedimentation Plan

Notice of Termination will be prepared and submitted by CIS Inc. on behalf of the County, to the Environmental Protection Division upon the establishment of acceptable vegetation on land in disturbed areas."

Section 161.3.01 PERSONNEL

Replace the first sentence of paragraph 2 of A. Duties of the Worksite Erosion Control Supervisor to read as follows:

"The Worksite Erosion Control Supervisor (WECS) shall be an employee of the Prime Contractor, shall have at least one year of experience directly related to roadway construction in a supervisory capacity and shall have successfully completed the Worksite Erosion Control Supervisor Certification Training sponsored by the Georgia County of Transportation." The WECS Certification must be current."

Replace the first sentence of paragraph 1 of C with the following:

"As a minimum the **Contractor** shall complete the permanent grassing, or temporary grassing and mulching, as appropriate, on all cut and fill slopes and shoulders on a bi-weekly basis during grading operations."

SECTION 161.04 EROSION CONTROL SCHEDULE:

Delete as written and substitute the following:

"EROSION AND SEDIMENTATION CONTROL PLAN: At the Preconstruction conference the Contractor shall present the proposed plans and schedules for construction of the Project in accordance with the requirements of this Section. The Plans shall be based on an analysis of project conditions and shall be in written form except for projects on which it is readily apparent that control of erosion is of a minor significance. This plan shall specifically indicate the schedule for clearing and grubbing, earthwork operations and construction of permanent erosion control features. It shall include provisions for implementing erosion control in critical areas near rivers, streams, lakes, tidal waters, reservoirs, canals, other impoundments, and in residential areas. The Contractor shall also outline the proposed methods of controlling erosion of haul roads and in borrow pits, material pits, and areas used for disposal of waste materials from the project.

This submission shall include but is not limited to the following:

- A. General overall Erosion and Sedimentation Plan

- B. Detailed breakdown of erosion control devices as required for different stages of construction.
- C. Set of marked plans or detailed drawings showing areas of control devices and purpose of each.
- D. Subsequent staging plans and specific site plans may be submitted to CIS Inc as the work progresses. These plans shall be submitted a minimum of two weeks in advance of construction to allow review by CIS Inc. They must have CIS Incs approval.

No work shall be started until the afore-mentioned plans and schedules have been accepted by Putnam County. The Contractor will be responsible for accomplishment of the Work in accordance with the accepted plans and schedules. The Director of Transportation may approve changes made necessary by unforeseen circumstances which are beyond the control of the Contractor.

On projects consisting of minor pavement widening less than four feet in width, Erosion Control and Sedimentation Plans will not be required. The existing vegetation is sufficient to prevent erosion."

The Contractor shall provide sufficient erosion and sedimentation controls as necessary or as directed by the County to prevent stormwater pollution or illicit discharges.

END OF SECTION

PUTNAM COUNTY, GEORGIA

PROJECT #15-1

**REIDS RD/PONDER PINES RD UNPAVED ROAD
IMPROVEMENT PROJECT**

SPECIAL PROVISIONS

Putnam County Board of Commissioners

SCOPE OF WORK

I. ROADWAYS:

- A. The specific project construction is shown on the construction plans dated 4/26/2014 and prepared by Patrick & Associates, Inc., which are available for downloading from the county web site.
- B. The Contractor shall be responsible for setting his own grades and ensure that his construction fits existing field conditions. The cost for the survey associated with this work shall be borne by the Contractor.

II. CONSTRUCTION ISSUES:

- A. This project includes the relocation of one (1) Central Georgia EMC pole and associated overhead AT&T pole. The relocation of these utilities will be performed by the respective Utility Providers. Coordination will be discussed at the pre-construction meeting.

SEQUENCE OF OPERATIONS

I. GENERAL:

- A. The purpose of this Special Provision is to provide a Sequence of Operations for construction of this project. This Special Provision also provides specific procedures that will permit vehicular and pedestrian traffic to pass through the area safely and with a minimum of inconvenience.
- B. This Special Provision sets forth specific procedures and does not relieve the **Contractor** of any responsibilities required by Specification Section 150, other Specifications, Plans, or the MUTCD.
- C. The **Contractor's** trucks and other vehicles shall travel in the direction of normal roadway traffic unless separated from the through traffic by adequate construction barriers approved by CIS Inc.
- D. The Contractor shall not perform work, close lanes, or move equipment or materials on any portions of the project from 7:00 PM Friday to 7AM Monday. Workday work hours shall be Monday thru Friday from 7AM to 5:00PM. Upon request, the County may be agreeable to specific dates contrary to this period. A written request to the County Manager identifying the reason for the request will be required.
- E. The **Contractor** shall submit to CIS Inc. at the preconstruction meeting a Critical Path Method schedule showing the various tasks, durations, dates and stages of the work. The schedule shall be updated monthly and submitted with the pay request for **Work** completed. CIS Inc. shall be notified in writing within seven days of any change if the schedule needs to be changed and what steps will be taken to overcome or make up the time.

II. ORDER OF WORK:

A. Non-Interstate Divided Highways

1. The **Contractor** shall not simultaneously perform Work on both the inside shoulder and outside shoulder on either direction of traffic flow when the Work is within 12 feet of the traveled way, unless such areas are separated by at least 3000 feet of distance in rural areas or at least 500 feet of distance in urban areas.

B. Non-Divided Highways

1. The **Contractor** shall not simultaneously perform Work on opposite sides of the roadway when the Work is within 12 feet of the traveled way, unless such areas are separated by at least 3000 feet of distance in rural areas or at least 500 feet of distance in urban areas.
2. On two-lane projects where full-width sections of the existing subgrade, base or surfacing are to be removed, and new base subgrade or surfacing is to be constructed, the **Contractor** shall maintain one-lane traffic through the construction areas by removing and replacing the undesirable material for half the width of the existing roadway at a time. Replacement shall be made such that paving is completed to the level of the existing pavement in the adjacent lane by the end of the Workday

C. Excavation

1. All areas within the limits of the Project, which are determined by CIS Inc to be damaged, due either directly or indirectly to the process of construction, shall be cleaned up, redressed and grassed. All surplus materials shall be removed and disposed of as required. Materials to be wasted shall be disposed of in accordance with Subsection 201.3.05.E of the current Specifications.
2. When trenching is required for drainage structures, the **Contractor** shall be responsible for testing the compaction of the backfill material using an independent testing laboratory. The results of the compaction test shall be provided to CIS Inc, as soon as possible. Failing compaction tests shall require the **Contractor** to re-compact the material and retest until the material passes the required specified compaction.

SPECIAL CONDITIONS

The special conditions contained herein are Project Specific. When there is a conflict between the General Conditions of the Contract Documents and these Special Conditions, the Special Conditions will govern the Work:

- A. The **Contractor** shall provide off-road parking areas within the construction area but not on private property (unless permission is granted by the property owner). The unauthorized parking of employees' vehicles and/or equipment will not be permitted along the shoulders or adjacent to the active traffic. It will be the **Contractor's** responsibility to prevent the violation of this provision. Failure to comply with the terms of this provision will result in the suspension of the Work. If the Contractor uses property or parking areas adjacent to the project he is responsible for obtaining permission from the respective lessee/owner to park on the property and shall be at his sole expense.

The **Contractor** shall provide staging areas for equipment, materials and personnel which do not hinder public access or traffic movements. Debris and trash will be cleaned up in these areas to the acceptance of the inspector prior to vacating the area. Any soil contaminated by fuel or oil spills will be excavated and disposed of in accordance with EPA and State requirements for hazardous materials. The **Contractor** shall make every effort to prevent fuel and oil spills.

- B. The **Contractor** shall notify the **CIS, Inc.** three (3) business days prior to beginning Work.
- C. When construction begins on this project, the **Contractor** will be required to continuously pursue the Work without interruption to the completion of each stage of Work.
- D. All work shall be subject to inspection and testing by Putnam County's testing firm. The County is responsible for providing the testing services except as noted in Special Provisions Section II C. 2.
- E. The Contract completion date shall be **120 DAYS FROM NOTICE TO PROCEED DATE or as approved by the Putnam County Manager. This time shall include Utility Relocations, which shall be coordinated by the Contractor.**
- F. In addition to the Putnam County Board of Commissioners and Collaborative Infrastructure Services, Inc., the selected Contractor shall also include the Morgan County Board of Commissioners as a named party in all insurance certificates
- G. One lane shall remain open at all times during the week day. Flagmen and other required traffic control devices shall be utilized when one lane is closed including all other times during the duration of the project. At the end of each work day, all lanes shall be opened to traffic.
- H. A traffic control plan shall be submitted to CIS, Inc. prior to the issuance of a NTP to the Contractor.
- I. The Contractor shall warrant and guarantee for a period of two (2) years from the date of punch list completion and acceptance from the County, that the completed work is free from defects due to faulty materials or workmanship. The Contractor shall promptly make such corrections as may be necessary to correct said defects. The County will give notice of defects with reasonable promptness. The Performance Bond shall remain in full force throughout the entire warranty period.

5. UTILITY CONFLICTS

Utility companies having known facilities that conflict with the construction of this project will notify the **County and the Contractor.** The various **Utility Providers** will adjust or relocate their facilities. The **Contractor's** duty is to notify the **County** of known conflicts.

It will be the **Contractor's** responsibility to conform with all the requirements of the Specifications as they relate to cooperation with utility owners and the protection of utility installations that exist on the Project. The **Contractor's** attention is directed to the requirement of Section 107, LEGAL REGULATIONS AND RESPONSIBILITY TO THE PUBLIC, with particular attention to Article 107.21. F

It shall be the responsibility of the **Contractor** to coordinate his Work with any Work to be performed by others in a Right-of-Way clearance and arrange a schedule of operations that will allow for completion of the Project without undue delay. Where stage construction is required it shall be the **Contractor's** responsibility to notify the utility owner when each stage of **Work** is completed and the site is available for utility Work to proceed.

It shall be the responsibility of the **Contractor** to determine the estimated time for relocation and adjustment of facilities of all utility companies and to consider in his bid all such relocations and adjustments.

In accordance with Article 105.6 of the specifications, the **County** shall not be liable for payment of any costs due to utility delays, inconvenience or damage sustained by the **Contractor** due to interference of any utilities, appurtenances, or the operation of moving them. Delays by utilities that effect the Contractors schedule will be considered by the County for potential time extensions (s). The Contractor

must document any such delays as applicable. Any changes in the Contract with regards to the project schedule will be assessed in accordance with Article 107.21.G.

The **Contractor** will not be paid for any delays or extra expense caused by utility facilities, obstructions, or any other items not being removed or relocated to clear construction in advance of his Work.

6. ADDENDUMS

The contents of Addendums will be incorporated into the respective sections of the final CONTRACT AGREEMENT, GENERAL CONDITIONS, and/or SPECIAL PROVISIONS. The **Contractor's** submitted Bid Proposal at the time of bid opening will also be incorporated into the Special Provisions as an Appendix, which will be part of the Contract.

APPENDIX A

ROADWAY PLAN SET

**(THIS INFORMATION IS AVAILABLE ON THE
COUNTY WEB SITE – PLANS DATED 4/26/2014)**

APPENDIX B
CONTRACTOR'S SUBMITTED BIDDING DOCUMENTS

REIDS RD

A.2

9/16/2015