

Addendum 2

City of Canton, Ohio
Purchasing Department
218 Cleveland Ave. SW, 4th floor
Canton, Ohio 44702

Ridgewood East Phase 1 - Part 1 Water Main Replacement Project and
Part 2 (22nd/24th Street NE) Roadway Reconstruction Project

Item/Project

Water Department

Responsible Department

Friday, November 30, 2018 at 2:00 PM local time

Bids Due On or Before

Bid Proposal Submitted By:

Company Name

Street Address

City

State

Zip

Contact Person

Phone No.

Email Address

**Ridgewood East Phase 1 - Part 1 Water Main Replacement Project and
Part 2 (22nd/24th Street NE) Roadway Reconstruction Project**

Invitation to Bid Change 1:

- A. In Appendix C: Technical Specifications and Drawings, plan sheet 17; the “Typical Water Service” detail shall be replaced with the attached detail.

**Ridgewood East Phase 1 - Part 1 Water Main Replacement Project and
Part 2 (22nd/24th Street NE) Roadway Reconstruction Project**

Addendum 2

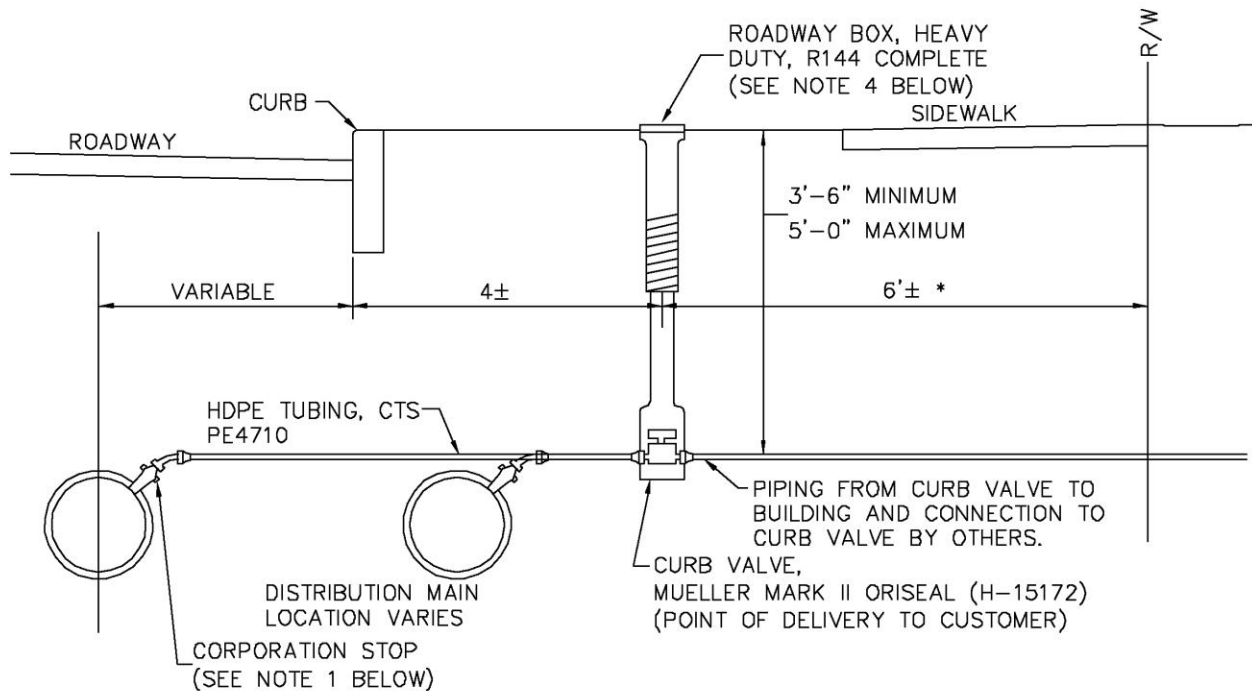

NOTES:

- 1.) CORPORATION STOP AND ASSEMBLY SHALL BE AS FOLLOWS:
 - 1" CORP. STOP ON DIP: INSTALL AT A 45° ANGLE, A MUELLER H-15000 CORPORATION STOP WITH A McDONALD 74750Q ELBOW.
 - 1" CORP. STOP ON PVC C909: INSTALL AT A 45° ANGLE, A MUELLER H-15000 CORPORATION STOP WITH A McDONALD 74750Q ELBOW AND A FORD, STAINLESS STEEL, EPOXY COATED TAPPING SADDLE (FC202 STYLE).
 - 1 ½" CORP. STOP: INSTALL AT A 45° ANGLE, A MUELLER H-15000 CORPORATION STOP WITH MUELLER H-15063 ELBOW AND A MUELLER H-15071 COMPRESSION FEMALE WITH INSERT COUPLING. ASSEMBLY SHALL ALSO CONSIST OF A FORD, STAINLESS STEEL, EPOXY COATED TAPPING SADDLE (FC202 STYLE).
 - 2" CORP. STOP: INSTALL AT A 45° ANGLE, A MUELLER H-10003 CORPORATION STOP WITH 2" IRON TOP, A STANDARD NO LEAD BRASS 45° ELBOW AND A MUELLER H-15428 COMPRESSION MALE WITH INSERT COUPLING. ASSEMBLY SHALL ALSO CONSIST OF A FORD, STAINLESS STEEL, EPOXY COATED TAPPING SADDLE (FC202 STYLE).
- 2.) NO SWIVEL ELBOWS WILL BE PERMITTED.
- 3.) A SERVICE CLAMP MUST BE USED WHEN THE MAIN SIZE IS 2 INCH OR SMALLER.
- 4.) HEAVY DUTY VALVE BOXES, COMPLETE, MUST BE USED IN PLACE OF ROADWAY BOXES WHEN LOCATED IN ROADWAYS OR ASPHALT DRIVES.
- 5.) APPROVED EQUALS MAY BE USED IN PLACE OF SPECIFIED ITEMS.

TYPICAL WATER SERVICE
(C94)