



City of Myrtle Beach
SOUTH CAROLINA

PURCHASING AND
MATERIALS MANAGEMENT

(843) 918-2170
FAX: (843) 918-2182

ADDENDUM 004

August 1, 2018

18-B0150

BOYS AND GIRLS CLUB SITEWORK

Attached please find an updated bid tab. The fence and dumpster screening is now to be part of the building package and has been removed from previous bid tab.

Attached please find specifications on a cleanout that has a solid lid, is pedestrian friendly and is lockable via hex head in order to prevent pulling lids off. This is to be used throughout the site.

Thank you for your interest in this project. We are sorry for any inconvenience this may have caused.

Ruth Burleson/Buyer
City of Myrtle Beach

1716Z1PT 1716APT DI Assembly

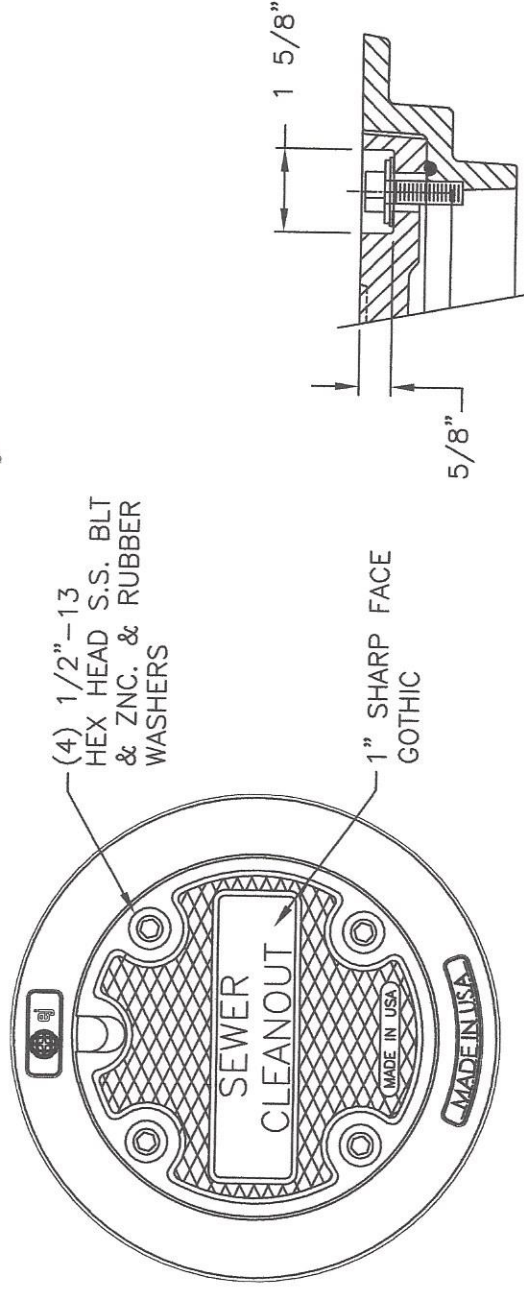

PLAN VIEW

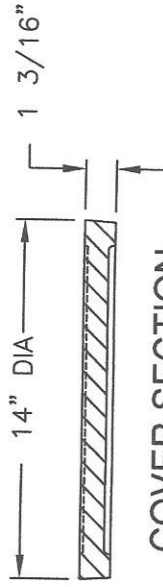

COVER SECTION

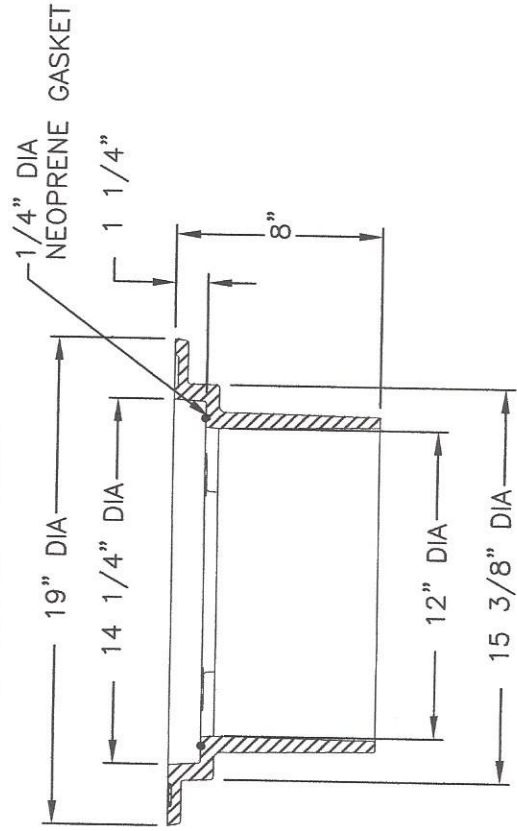

FRAME SECTION

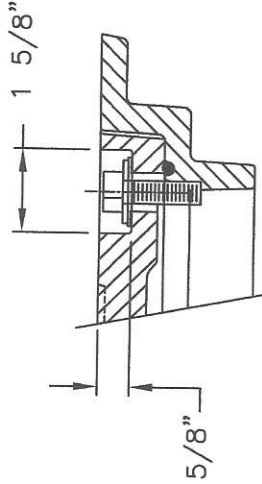

BOLT DETAIL

Product Number

00171650

Design Features

- Materials
- Cleanout/Monument Box Frame
- Gray Iron (CL35B)
- Cleanout/Monument Box Cover
- Ductile Iron (70-50-05)

-Design Load

Airport Extra Heavy Duty

-Open Area

n/a

-Coating

Undipped

- Designates Machined Surface

Certification

-ASTM A48

-ASTM A536

-Country of Origin: USA

Major Components

00171617

00171623

Drawing Revision

08/20/2008 Designer: GAD

03/02/2016 Revised By: DVD

Disclaimer

Weights (lbs./kg) dimensions (inches/mm) and drawings provided for your guidance. We reserve the right to modify specifications without prior notice.

CONFIDENTIAL: This drawing is the property of EJ GROUP, Inc., and embodies confidential information, registered marks, patents, trade secret information, and/or know how that is the property of EJ GROUP, Inc. Copyright © 2012 EJ GROUP, Inc. All rights reserved.

Contact

800 626 4653

ejco.com

Boys & Girls Club

I

SITE WORK		UNIT	QUANT.	UNIT PRICE	TOTAL
Clearing & Grubbing					
1	Mobilization	LS			
2	City Licence Fees	LS			
3	Silt Fence	LF			
4	Construction Entrance	EA			
5	Tree Protection	EA			
6	Clearing & Grubbing	LS			
7	Strip Site 6" and Haul Off	CY			
8	Demo Existing Concrete	SY			
9	Demo Existing Curb	LF			
Subtotal:					
Site Grading					
10	Construction Staking	LS			
11	Imported Fill	CY			
12	On-Site Cut to Fill	CY			
13	Sub-Grade for Parking	SY			
14	Sub-Grade for Curb	LF			
15	Fine Grade for Parking	SY			
16	Fine Grade for Curb	LF			
17	Grade Green Areas	LS			
Subtotal:					
Stormwater System					
18	6" Underdrain	LF			
19	15" RCP	LF			
20	Install Catch Basin With Frame & Grate	EA			
21	Install Curb Inlet With Hooded Frame & Grate	EA			
22	Install Control Structure With Stainless Steel Grate	EA			
23	Tie to Existing Drainage Structure	EA			
24	Drainage Structure Inlet Protection	EA			
25	Pipe Outlet Protection	EA			
26	6" PVC	LF			
27	12" PVC	LF			
28	6" Drainage Cleanout	EA			
29	12" Drainage Cleanout	EA			
30	6" Infiltration Trench Within Pond	LF			
Subtotal:					
Driveways & Parking Areas					
31	6" Stone Base In Parking Area	SY			
32	6" Stone Base for Curb	SY			
33	18" Curb & Gutter	LF			
34	Concrete Washout	EA			
35	Curb Tie-Ins	EA			
36	6" Concrete Sidewalk	SY			
37	ADA Ramp With Truncated Domes	EA			
38	Equipment Service Area	EA			
Subtotal:					
PROJECT GRAND TOTAL					