

---

**INVITATION TO BID**

---

**Dodge Durango Rear Cargo Weapon Cabinets**

Sealed bids, invited by the City of Knoxville, will be received by the Purchasing Division of the City of Knoxville, in Room 667-674, City County Building; 400 Main Street; Knoxville, Tennessee, until **11:00:00 a.m. (Eastern Time) on November 22, 2022** at which time they will be opened and publicly read aloud and a contract awarded as soon thereafter as practicable for Dodge Durango Rear Cargo Weapon Cabinets.

**The bid opening may be viewed virtually on Zoom through this link:**

Topic: ITB - Dodge Durango Rear Cargo Weapon Cabinets  
Time: Nov 22, 2022 11:00 AM Eastern Time (US and Canada)

Join Zoom Meeting  
<https://us02web.zoom.us/j/86932507675?pwd=MGhPc2poakc2YnArVHFrQnE0K1hHUT09>

Meeting ID: 869 3250 7675  
Passcode: 180861  
One tap mobile  
+13017158592,,86932507675#,,,,\*180861# US (Washington DC)  
+13092053325,,86932507675#,,,,\*180861# US

Dial by your location

- +1 301 715 8592 US (Washington DC)
- +1 309 205 3325 US
- +1 312 626 6799 US (Chicago)
- +1 646 931 3860 US
- +1 929 205 6099 US (New York)
- +1 564 217 2000 US
- +1 669 444 9171 US
- +1 669 900 6833 US (San Jose)
- +1 689 278 1000 US
- +1 719 359 4580 US
- +1 253 215 8782 US (Tacoma)
- +1 346 248 7799 US (Houston)
- +1 360 209 5623 US
- +1 386 347 5053 US
- +1 507 473 4847 US

Meeting ID: 869 3250 7675  
Passcode: 180861  
Find your local number: <https://us02web.zoom.us/j/86932507675>

## Scope of Work:

The City of Knoxville is requesting pricing for **forty (40) Dodge Durango Rear Cargo Weapon Cabinets** and a price lock for potential future purchases under a one (1) year agreement with two (2) optional one (1) year renewals. This specification describes a rear elevated custom storage cabinet for the Knoxville Police Department for use in forty (40) recently ordered Dodge Durango PPVs. See specifications below and Attachment A for measurements, set up of the cabinets required, and the placement. NOTE: The issuance of the blanket purchase order does not guarantee purchase of quantities beyond the initial 40 weapon cabinets.

Bidders are expected to supply a top quality product and poorly built cabinets will not be accepted. In addition, winning bidder must supply the first cabinet to the delivery address provided below for inspection and approval from the Knoxville Police Department before the remaining 39 are built. It is the responsibility of the bidder to ensure the cabinet will fit properly in the Durangos with the rear cargo barrier brackets.

Freight/delivery and installation shall be included in the price. Delivery address is 3409 Vice Mayor Jack Sharp Road, Knoxville, TN 37914. Delivery/install time may be a determining factor in award. It is preferred that all 40 be installed at one time and the City will coordinate an installation date with winning bidder once all Durangos have arrived.

## Specifications:

### ADDITIONAL SPECIFICATIONS

- elevated drawer vault for PPV Durango
- minimum 300lb heavy duty slides
- spring loaded handles
- entire vault to be coated with Raptor Liner (or equal) for ease of cleaning
- include 1 drawer divider
- bottom of inside of drawer to be carpeted with agreed upon color
- carpet shall be removable for ease of cleaning
- reinforced metal edging on drawer and top of vault to reduce potential of being pried open
- 9000 series Kabba lock with combination lock with key override (no substitutions for lock)

Bidders are to include a drawing with measurements of the cabinet being bid. Bids turned in without the drawing shall be considered non-responsive and will be rejected.

Please state cabinet warranty as well as installation warranty on line below:

---

### **ATTACHMENT A**

Drawing shows approximate measurements and placement to fit into the rear cargo area of PPV Dodge Durango.

The vehicles will be upfit with rear cargo barriers from ProGard, so there will be brackets that extend into the cargo area, see stock picture below. Bidders are expected to submit accordingly based on the supplied drawing. The drawing contains required dimensions and specifications.



- A TOTAL TOP WIDTH OF VAULT EXT DIM APPROX 40.5" +OR-
- B TOTAL HEIGHT OF VAULT EXT DIM APPROX 13" +OR-
- C TOTAL LENGTH OF VAULT EXT DIM APPROX 25.5" +OR- <sup>LOCK & HANDLE</sup>
- D INT DRAWER HEIGHT APPROX 10" +OR-
- E INT DRAWER WIDTH APPROX 36" +OR-

I DRAWER DIVIDER WIDTH OF DRAWER AS NECESSARY TO MATCH.

NUTS & BOLTS FOR REAR CARGO BARRIER MOUNTS

1" L CHANNEL SUPPORT FROM EACH REAR CARGO SIDE BRACE TO ATTACH TO BOTTOM FACE OF VAULT

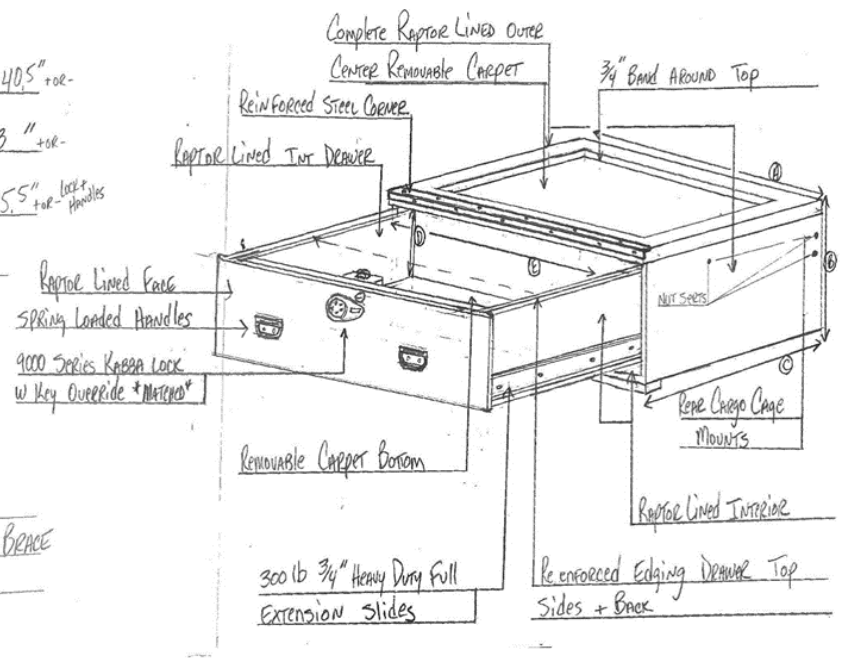

## Renewal Pricing:

All agreement pricing shall remain firm and fixed for the period of one year following contract execution. After the completion of the first full year term and any renewal terms thereof, the Contractor may adjust the contract price in accordance with the increase or decrease, if any, in the **Producer Price Index (PPI), using a basis of such adjustment the “All other miscellaneous fabricated metal products PCU332999332999N” (“Index”) not seasonally adjusted** for the month prior to the term expiration, published by the Bureau of Labor Statistics of the United States Department of Labor, excepting that the maximum annual increase shall not exceed 5.0% (“annual cap”). The City reserves the right to renegotiate the annual cap based on extreme market conditions. The new rate for each year will be calculated as per the following example:

CPI for current period (Current September Index):	236.27
- CPI for previous period (Prior year September Index):	223.37
= Index point change	12.9

Index point change (12.9) ÷ Prior year September Index (223.37) = 0.058 x 100 = 5.8% index change  
5.0% Annual Cap x current **contract price = New Price**

The increase in the unit prices may occur after Contractor has given the City written notice of such change and received written approval of the increase from the City's Contract Manager.

The City reserves the right to negotiate the annual cap for future awards based on extreme market conditions.

## Delivery Instructions:

Delivery will be to:  
3409 Vice Mayor Jack Sharp Rd.  
Knoxville, TN 37914

Price is to include all charges, FOB Destination to the 3409 Vice Mayor Jack Sharp Road, Knoxville, TN 37914. Inside delivery is required. No after hour, holiday or weekend deliveries will be accepted.

## Bid Submission Requirements:

Bidders must furnish the following information in writing with their submission:

1. [Bid Form](#) showing bidder's name, address, quoted price, business license number, date of expiration of business license. A copy of the bidder's current business license may be submitted in lieu of providing the license expiration date.
2. Warranty Information
3. [Non-Collusion Affidavit](#)
4. [Iran Divestment Act Certification of Non-Inclusion](#)
5. [Diversity Business Enterprise \(DBE\) Program form](#)

## Instructions and Conditions:

1. Sealed bids will be received by the Purchasing Division of the City of Knoxville in Room 667-674, City/County Building; 400 Main Street; Knoxville, Tennessee 37902 until **November 22, 2022, at 11:00:00 a.m.**, at which time they will be publicly opened and read aloud and the contract awarded as soon as practicable. **No bid will be received or accepted after the above-**

**specified time for the opening of bids.** Bids that arrive late due to the fault of U. S. Postal Service, United Parcel Service, DHL, FEDEX, any delivery/courier service, or any other carrier of any sort are still considered late and shall not be accepted by the City. Such bids shall remain unopened and will be returned to the submitting entity upon request.

2. The City of Knoxville reserves the right to reject any or all bids, to accept or reject any items thereon, to waive technicalities or informalities, to split orders if in the best interest of the City, to evaluate bids by various criteria, and to accept any bid which, in its opinion, may be for the best interest of the City.
3. Included in the Invitation to Bid is an affidavit in proof that the undersigned has not entered into any collusion with any person in respect to this bid or any other bid. The Bidder will be required to execute and submit this affidavit with the sealed bid. Also included is the Diversity Business Program contracting packet. Submissions must indicate on the enclosed form whether or not the bidder intends to use subcontractors and/or suppliers from one of the defined groups. Bidders are advised that the City tracks use of such use, but it does not influence or affect evaluation or award.
4. **NO CONTACT POLICY:** After the posting of this solicitation to the Purchasing Division's website, any contact initiated by any proposer with any City of Knoxville representative concerning this proposal is strictly prohibited, unless such contact is made with the Purchasing Division representative listed herein or with said representative's authorization. Any unauthorized contact may cause the disqualification of the proposer from this procurement transaction.
5. **INCLEMENT WEATHER:** During periods of inclement weather, the Purchasing Division will enact the following procedures with regard to solicitations and weather delays:
  - If City offices are closed due to inclement weather on the date that bids/proposals/qualifications/letters of interest are due into the Purchasing Office, all solicitations due that same day will be moved to the next operational business day.
  - The City of Knoxville shall not be liable for any commercial carrier's decision regarding deliveries during inclement weather.
6. Each bid delivered via hardcopy must be submitted in a sealed envelope, addressed to the Purchasing Division; City of Knoxville; City/County Building; 400 Main Street, Room 667-674; Knoxville, Tennessee, 37902. Each sealed envelope containing a bid must be plainly marked on the outside as: **"ITB-Dodge Durango Rear Cargo Weapon Cabinets."**
7. Electronic submissions shall be submitted online through the City's Procurement website. DO NOT EMAIL YOUR SUBMISSION. If submitting electronically, a paper bid is not required.
8. All proposers/bidders must register as a vendor in order to submit an electronic file.

**Step One:** Register as a City of Knoxville vendor (Vendors are encouraged to complete this step now to ensure seamless submission process prior to deadline.) To register as a vendor: Visit the website at [www.knoxvilletn.gov/purchasing](http://www.knoxvilletn.gov/purchasing) Click the "Vendor Registration" tab; then "Click here to register as a City of Knoxville Vendor" Follow the prompts to complete online registration. Note: You will be asked for a PIN. This PIN will be emailed to you and may be sent to your spam or junk folder.

**DO NOT WAIT UNTIL SUBMISSION DEADLINE TO REGISTER AS A VENDOR.** The electronic submission link will be disabled at 11:00:00 a.m. Eastern time. Vendors will not have the ability to submit any electronic files once the deadline has passed and the City will accept no late submissions.

**Step Two:** Submit all materials electronically as one (1) file to City's Procurement website PRIOR to 11:00:00 a.m. (Eastern Time) on November 22, 2022. To submit electronic file: Visit the

procurement website at [www.knoxvilletn.gov/bids](http://www.knoxvilletn.gov/bids) Click "ITB - Dodge Durango Rear Cargo Weapon Cabinets ", Click "Submit Bid" (red button located at top of screen) Follow the prompts to upload and submit electronic file. The City prefers only one (1) bid file per submission. Files MUST use the following naming convention, listing the firm's name followed by the title of the project. Example: "ABC Company-Dodge Durango Rear Cargo Weapon Cabinets.pdf." Should you need to merge multiple documents into one PDF please utilize Google to download a free software intended for merging pdf documents.

9. All bids must be made on the Bid Form supplied with the contract documents, and no interlineations, excisions, or special conditions shall be made or included in the Bid Evaluation Sheet by the Bidder. **Any bid on which there is an alteration of or departure from the Bid Form may be considered irregular and may be rejected.** All bids must be signed in full by the Bidder or Bidders in their business name or style when submitted and must show his or their complete address.
10. No bidder may withdraw his bid for a period of 60 days after the actual date of the opening thereof.
11. Prior to submitting their bids, bidders are to be registered with the Purchasing Division through the City of Knoxville's online Vendor Registration system. Instructions for registering on-line are available at [www.knoxvilletn.gov/purchasing](http://www.knoxvilletn.gov/purchasing).
12. **Bid submissions from un-registered bidders may be rejected.**
13. Payment for completed services delivered to and accepted by the City shall be at the contract price.
14. State make or brand on each item. If quoting on other than the make, model, or brand specified, the manufacturer's name and catalog number must be given, along with warranty information and detailed specifications. Because the City is committed to environmentally sound practices, brands are expected to be procured with environmental responsibility in mind.
15. Time of delivery is part of the consideration and must be stated in definite terms; time of delivery is guaranteed by the bidder and must be adhered to upon award. If time varies on different items, the bidder shall so state.
16. All quotations must be signed with the firm name and by a responsible officer or employee. Obligations assumed by such signature must be fulfilled.
17. Bidders shall verify bids before submission, as bids cannot be withdrawn or corrected after being opened. Bids will be evaluated by unit price.
18. Prices are considered FOB Knoxville unless otherwise stated in the Invitation to Bid.
19. By execution and delivery of a bid submission, the bidder agrees that any additional terms and conditions, whether submitted to the City purposely or inadvertently, shall have no force or effect.
20. Bidders must comply with the President's Executive Orders No.11246 and 11375 which prohibit discrimination in employment regarding race, color, religion, sex or national origin. Bidders must not maintain or provide for their employees any facilities that are segregated on the basis of race, color, religion or national origin. Bidders must also comply with Title VI of the Civil Rights Act of 1964, Copeland Anti-Kick Back Act, the Contract Work Hours and Safety Standard Act, Section 402 of the Vietnam Veterans Adjustment Act of 1974 and Section 503 of the Rehabilitation Act of 1973, all of which are herein incorporated by reference.

21. ADA Compliance. With regard to the services performed under this Agreement, the Contractor will comply with all applicable requirements of the Americans with Disabilities Act, 42 U.S.C. § 12101, *et seq.* ("ADA"). The Contractor agrees that it will defend, indemnify and hold the City harmless against any and all claims, demands, suits or causes of action which arise out of any negligent and/or intentional act or omission by the Contractor, its employees, agents or representatives that violates the ADA. The Contractor agrees that the City will not be responsible for any cost or expenses arising from the Contractor's failure to comply with the ADA.
22. All bidders must comply with Title VI of the Civil Rights Act of 1964, as codified in 42 U.S.C. 2000d. The successful bidder must follow Title VI guidelines in all areas including hiring practices, open facilities, insurance, and wages. The City of Knoxville reserves the right to review all compliance records by a contract compliance officer designated by the City.
23. No interpretation of the meaning of the plans, specifications, or other pre-bid documents will be made to any bidder orally. Each request for such interpretation should be in writing addressed to **Suzanne Daws, Procurement Specialist** for the City of Knoxville, 400 Main Street, Room 667, Knoxville, TN 37902, or emailed to [sdaws@knoxvilletn.gov](mailto:sdaws@knoxvilletn.gov). To be given consideration, such requests/questions must be received at least five (5) business days prior to the date fixed for the opening of bids. Any and all such interpretations and any supplemental instructions will be in the form of written addenda to the specifications which, if issued, will be posted to the City's website at [www.knoxvilletn.gov/bids](http://www.knoxvilletn.gov/bids). Submitting organizations are strongly encouraged to view this website often to see if addenda are posted. Failure of any bidder to receive such addendum or interpretation shall not relieve such Bidder from any obligation under his bid as submitted. All addenda so issued shall become part of the Contract Documents.
24. Attention of all bidders is directed to the set off provision contained in Article II, Section 24-33, entitled, "Debts owed by persons receiving payments other than salary", and Section 2-1049 entitled "Receipt of benefits from City contracts by council members, employees, and officers of the City" of the Code of the City of Knoxville.
25. Before a Purchase Order is issued, the submitting entity, if selected, **must** provide the City Purchasing Division with a copy of its valid business license **or** with an affidavit explaining why it is exempt from the business licensure requirements of the city or county in which it is headquartered. If a contract is signed, the contractor's business license shall be kept current throughout the duration of the contract, and the contractor shall inform the City of changes in its business name or location. Any Agreement to purchase resulting from this Invitation to Bid shall be governed by and construed in accordance with the substantive laws of the State of Tennessee and its conflict of laws provisions. Venue for any action arising between the City and the Vendor from the Agreement shall lie in Knox County, Tennessee.
26. In compliance with Tennessee state law, bids must be accompanied by a certification attesting that, to the best of the bidder's knowledge, the bidder does not engage in investment activities in Iran. The Iran Divestment Act of 2014 Certification of Noninclusion form may be found in this solicitation document.
27. By acceptance and delivery of the Purchase Order resulting from the award of this Invitation to Bid, the Vendor agrees to the following:

Contractor shall defend, indemnify and hold harmless the City, its officers, employees and agents from any and all liabilities which may accrue against the City, its officers, employees and agents or any third party for any and all lawsuits, claims, demands, losses or damages alleged to have arisen from an act or omission of Contractor in performance of this Agreement or from Contractor's failure to perform this Agreement using ordinary care and skill, except where such injury, damage, or loss was caused by the sole negligence of the City, its agents or employees.

Contractor shall save, indemnify and hold the City harmless from the cost of the defense of any claim, demand, suit or cause of action made or brought against the City alleging liability referenced above, including, but not limited to, costs, fees, attorney fees, and other expenses of any kind whatsoever arising in connection with the defense of the City; and Contractor shall assume and take over the defense of the City in any such claim, demand, suit, or cause of action upon written notice and demand for same by the City. Contractor will have the right to defend the City with counsel of its choice that is satisfactory to the City, and the City will provide reasonable cooperation in the defense as Contractor may request. Contractor will not consent to the entry of any judgment or enter into any settlement with respect to an indemnified claim without the prior written consent of the City, such consent not to be unreasonably withheld or delayed. The City shall have the right to participate in the defense against the indemnified claims with counsel of its choice at its own expense.

Contractor shall save, indemnify and hold City harmless and pay judgments that shall be rendered in any such actions, suits, claims or demands against City alleging liability referenced above.

The indemnification and hold harmless provisions of this Agreement shall survive termination of the Agreement.



## Submission Forms



## Bid Form

TO: Purchasing Division  
City of Knoxville  
Suite 667-674  
City/County Building  
400 Main Street  
Knoxville, TN 37902

Having carefully examined the specifications entitled "**ITB-Dodge Durango Rear Cargo Weapon Cabinets**" to open on **November 22, 2022, at 11:00:00 a.m.** and the other Contract Documents and addenda, we hereby propose to furnish the equipment, and delivery as described herein for the following sum:

BID: Total charge (includes shipping): \_\_\_\_\_

GUARANTEE of delivery no later than: \_\_\_\_\_ after awarded. \_\_\_\_\_ (Bidder must initial)

Firm Name: \_\_\_\_\_

Official Address: \_\_\_\_\_  
\_\_\_\_\_  
\_\_\_\_\_

DUNS #: \_\_\_\_\_ Business License Expiration Date: \_\_\_\_\_

By: \_\_\_\_\_  
Signature

Name: \_\_\_\_\_  
Printed

Date: \_\_\_\_\_

Title: \_\_\_\_\_

Email: \_\_\_\_\_

Phone: \_\_\_\_\_

## NON-COLLUSION AFFIDAVIT OF PRIME BIDDER

State of \_\_\_\_\_

County of \_\_\_\_\_

\_\_\_\_\_, being first duly sworn, deposes and says that:

1. He/She is the \_\_\_\_\_ of \_\_\_\_\_, the firm that has submitted the attached Bid;
2. He/She is fully informed respecting the preparation and contents of the attached Bid and of all pertinent circumstances respecting such Bid;
3. Such Bid is genuine and is not a collusive or sham Bid;
4. Neither the said Bid nor any of its officers, partners, owners, agents, representatives, employees, or parties in interest, including this affiant, has in any way colluded, conspired, connived or agreed, directly or indirectly, with any other Bidder, firm or person to submit a collusive or sham Bid in connection with the Contract for which the attached Bid has been submitted or to refrain from proposing in connection with such Contract, or has in any manner, directly or indirectly, sought by agreement or collusion or communication or conference with any other Bidder, firm, or person to fix the price or prices in the attached Bid or of any other Bidder, firm, or person to fix any overhead, profit, or cost element of the bid price or the bid price of any other Bidder, or to secure through any collusion, conspiracy, connivance or unlawful agreement any advantage against the City of Knoxville or any person interested in the proposed Contract; and
5. The price or prices quoted in that attached Bid are fair and proper and are not tainted by any collusion, conspiracy, connivance or unlawful agreement on the part of the Bidder or any of its agents, representatives, owners, employees, or parties in interest, including this affidavit.

(Signed): \_\_\_\_\_

Title: \_\_\_\_\_

Subscribed and sworn to before me this \_\_\_\_\_ day of \_\_\_\_\_, 20\_\_.

\_\_\_\_\_  
NOTARY PUBLIC

My Commission expires \_\_\_\_\_

## Iran Divestment Act

### Certification of Noninclusion

**NOTICE:** Pursuant to the Iran Divestment Act, Tenn. Code Ann. § 12-12-106 requires the State of Tennessee Chief Procurement Officer to publish, using creditable information freely available to the public, a list of persons it determines engage in investment activities in Iran, as described in § 12-12-105. Inclusion on this list makes a person ineligible to contract with the state of Tennessee; if a person ceases its engagement in investment activities in Iran, it may be removed from the list. A list of entities ineligible to contract in the State of Tennessee Department of General Services or any political subdivision of the State may be found here:

[https://www.tn.gov/content/dam/tn/generalservices/documents/cpo/cpo-library/public-information-library/List of persons pursuant to Tenn. Code Ann. 12-12-106 Iran Divestment Act updated 7.7.17.pdf](https://www.tn.gov/content/dam/tn/generalservices/documents/cpo/cpo-library/public-information-library/List_of_persons_pursuant_to_Tenn._Code_Ann._12-12-106_Iran_Divestment_Act_updated_7.7.17.pdf)

By submission of this bid, each bidder and each person signing on behalf of any bidder certifies, and in the case of a joint bid each party thereto certifies as to its own organization, under penalty of perjury, that to the best of its knowledge and belief that each bidder is not on the list created pursuant to T.C.A. § 12-12-106.

Vendor Name (Printed)	Address
By (Authorized Signature)	Date Executed
Printed Name and Title of Person Signing	

NOTARY PUBLIC:

Subscribed and sworn to before me this \_\_\_\_\_ day of \_\_\_\_\_, 2\_\_\_\_\_.

My commission expires: \_\_\_\_\_

## Diversity Business Enterprise Program (DBE) PROGRAM

The City of Knoxville strongly encourages prime contractors to employ diverse businesses in the fulfillment of contracts/projects for the City of Knoxville.

The City of Knoxville's Fiscal Year 2022 goal is to conduct 4.3% of its business with minority owned businesses, 10.7% of its business with women-owned businesses, and 37.1% with small businesses.

While the City cannot engage (pursuant to state law) in preferential bidding practices, the City does **strongly encourage** prime contractors to seek out and hire diverse businesses in order to help the City meet its goals as stated above. As such, the City encourages prime contractors to seek out and consider competitive sub-bids and quotations from diverse businesses.

For DBE tracking purposes, the City requests that prime contractors who are bidding, proposing, or submitting statements of qualifications record whether or not they plan to employ DBE's as sub-contractors or consultants. With that in mind, please fill out, sign and submit (with your bid/proposal) the following sub-contractor/ consultant statement.

### CITY OF KNOXVILLE DIVERSITY BUSINESS DEFINITIONS

Diversity Business Enterprise (DBE's) are minority-owned (MOB), women-owned (WOB), service-disabled veteran-owned (SDVO), and small businesses (SB), who are impeded from normal entry into the economic mainstream because of past practices of discrimination based on race or ethnic background. These persons must own at least 51% of the entity and operate or control the business on a daily basis.

Minority: A person who is a citizen or lawful admitted permanent resident of the United States and who is a member of one (1) of the following groups:

- a. African American, persons having origins in any of the Black racial groups of Africa;
- b. Hispanic American, persons of Mexican, Puerto Rican, Cuban, Central or South American or other Spanish culture or origin, regardless of race;
- c. Native American, persons who have origin in any of the original peoples of North America
- d. Asian American, person having origins in any of the original peoples of the Far East, Southeast Asia, the Indian subcontinent, or the Pacific Islands.

Minority-owned business (MOB) is a continuing, independent, for profit business that performs a commercially useful function, and is at least fifty-one percent (51%) owned and controlled by one (1) or more minority individuals.

Woman-owned business (WOB) is a continuing, independent, for profit business that performs a commercially useful function, and is at least fifty-one percent (51%) owned and controlled by one (1) or more women.

Service Disabled Veteran-owned business (SDOV) is a continuing, independent, for profit business that performs a commercially useful function, owned by any person who served honorably on active duty in the armed forces of the United States with at least a twenty percent (20%) disability that is service connected. Meaning such disability was incurred or aggravated in the line of duty in the active military, naval or air service, and is at least fifty-one percent (51%) owned and controlled by one (1) or more service disabled veteran.

Small Business (SB) is a continuing, independent, for profit business which performs a commercially useful function and has total gross receipts of not more than ten million dollars (\$10,000,000) average over a three-year period or employs no more than ninety-nine (99) persons on a full-time basis.

**Subcontractor/Consultant Statement**  
(TO BE SUBMITTED IN THE BID/PROPOSAL ENVELOPE)

We \_\_\_\_\_ do certify that on the  
(Bidder/Proposer Company Name)

\_\_\_\_\_  
(Project Name)

\$ \_\_\_\_\_  
(Amount of Bid)

**Please select one:**

**Option A: Intent to subcontract using Diverse Businesses**

A Diversity business will be employed as subcontractor(s), vendor(s), supplier(s), or professional service(s). The estimated **dollar value** of the amount that we plan to pay is:

\$ \_\_\_\_\_  
Estimated Amount of Subcontracted Service

<b>Diversity Business Enterprise Utilization</b>			
Description of Work/Project	Amount	Diverse Classification (MOB, WOB, SB, SDOV)	Name of Diverse Business

**Option B: Intent to perform work “without” using Diverse Businesses**

We hereby certify that it is our intent to perform 100 % of the work required for the contract, work will be completed without subcontracting, or we plan to subcontract with non-Diverse companies.

DATE: \_\_\_\_\_ COMPANY NAME: \_\_\_\_\_

SUBMITTED BY: \_\_\_\_\_ TITLE: \_\_\_\_\_  
(Authorized Representative)

ADDRESS: \_\_\_\_\_

CITY/STATE/ZIP CODE: \_\_\_\_\_

TELEPHONE NO: \_\_\_\_\_