



# MERIWETHER COUNTY

**BID REQUEST**

**FOR**

**MERIWETHER COUNTY**

**INSTALLATION OF BOX CULVERT AND  
ROADWAY CONSTRUCTION ON**

**STRICKLAND TOWN ROAD**

**@**

**PINEY WOODS CREEK**

**INSTALLATION OF BOX CULVERT AND  
ROADWAY CONSTRUCTION ON  
STRICKLAND TOWN ROAD  
@  
PINEY WOODS CREEK**

**TABLE OF CONTENTS**

<b>Section</b>	<b>Page</b>
<b>1. Proposal</b>	
<b>1A Information &amp; Instructions</b>	<b>3-9</b>
<b>1B Project Scope &amp; Description of Work</b>	<b>10</b>
<b>1C Payment for Work Performed</b>	<b>11</b>
<b>Bid Proposal Form</b>	<b>12</b>
<b>2. Bid Schedule</b>	<b>13-14</b>
<b>3. Bid Bond</b>	<b>15-16</b>
<b>4. Agreement/Contract</b>	<b>17-19</b>
<b>5. Performance Bond</b>	<b>20-21</b>
<b>6. Payment Bond</b>	<b>22-24</b>
<b>7. Contractor &amp; Sub-Contractors Affidavit (E Verify)</b>	<b>25-27</b>
<b>8. General Conditions</b>	<b>28-39</b>
<b>9. Attachments</b>	<b>40-48</b>

SECTION 1  
**PROPOSAL**

**1A INFORMATION AND INSTRUCTIONS**

Installation of Box Culvert and roadway reconstruction of Strickland Town Road.

**General**

The Meriwether County Board of Commissioners reserves the right to waive any requirements, formalities or informalities or to reject any and all proposals, to evaluate proposals, and to accept any proposal that, in its opinion, may be in the best interest of the county.

**Purpose**

Meriwether County is soliciting bids from qualified contractors for removal and proper disposal of existing culverts and debris, installation of box culvert with wing walls, and necessary construction to repair Strickland Town Road at construction site.

**Methodology**

Contractor selection for this project will involve concurrent review and evaluation of bid proposals. Evaluation will be based on the following criteria:

- Experience and Record of performance on similar projects
- Qualification of the contractor
- Expertise offered by the contractor in relation to the anticipated project task
- Approach to providing services required
- Availability of personnel to perform the work
- Proposed contract amount

The County will consider contractors not complying with all requirements of this request non-responsive and disqualified from further consideration.

**Proposal Deadline**

Contractors interested in the project described in the Scope of Work must submit two (2) copies of their competitive bid.

All proposals shall be sealed and clearly marked as indicated and submitted to the Meriwether County Board of Commissioners, 17234 Roosevelt Highway, Building B. Greenville, GA by **12:00 noon on Thursday, June 15th, 2023.**

**Meriwether County Board of Commissioners**

**Your Company Name**

**Proposal for Strickland Town Road**

**Mandatory Pre-Bid Meeting:**

**All interested contractors must attend mandatory pre-bid meeting at the project site as follows:**

**Strickland Town Road – June 5, 2023, at 10:00 a.m.**

**Bid Format**

Bids must be submitted and under a single cover in the format outline below:

**Performance Record:** Provide one-page summaries of five (5) projects in progress or completed within the past five years similar in nature, scope and complexity. Provide reference names and telephone numbers for each project.

**Contractor Qualifications:** Provide an organizational chart or list of key construction personnel proposed for assignment to the project. Qualifications of the project manager and other key personnel and their relationship to the project should be noted. Key personnel listed and shall indicate:

- Name, discipline, title, and project assignment;
- Years of relevant experience
- Academic degree(s), discipline, and year received;
- Professional registrations;
- Office location; and
- Experience relevant to the project.

**Expertise and Experience:** Document specialized expertise, resources, and experience as they relate to the construction of the proposed project.

**Project Approach:** Provide a detailed approach to the proposed project. A schedule must be provided indicating project tasks duration and the estimated completion date of the project.

**Availability:** List the names and address of the contractors and any subcontractors who will perform the work described in this request.

**Bid Proposal:** The County has provided the culvert size for the project.

The required width of paving will match existing widths on each road. Minimum shoulder width of 6 feet will be required beyond the edge of pavement. Additional shoulder width may be necessary if guardrail is required based upon GDOT guardrail warrants. Maximum slope for embankments shall be 2:1.

**Contact Person**

Questions concerning the request for proposals should be directed in writing via email to:

Bill Cawthorne  
Meriwether County Board of Commissioners  
17234 Roosevelt Highway, Building B.  
Greenville, Georgia 30222  
706-672-1314  
706-672-4465 fax  
[b.cawthorne@meriwethercountyga.gov](mailto:b.cawthorne@meriwethercountyga.gov)

**Questions must be received in writing no later June 6, 2023, at 5:00 p.m. All questions and responding answers will be provided to firms or individuals who have received proposal packages at least 72 hours prior to the proposal deadline.**

**Non-discrimination Policy** – As set forth in the Americans with Disabilities Act of 1992, the Meriwether County government does not discriminate on the basis of disability and will assist citizens with special need given proper notice (seven working days). For more information regarding this issue, please contact County Clerk, Beverly Thomas at (706) 672-1314. It is the policy of Meriwether County government not to discriminate on the basis of race, gender, age or national origin. Meriwether County encourages the considerations of DEB's (and Disadvantage Business Enterprises).

**GENERAL CONDITIONS:**

**INSTALLATION OF BOX CULVERT WITH WING WALLS AND ROADWAY CONSTRUCTION ON  
STRICKLAND TOWN ROAD  
@  
PINEY WOODS CREEK**

**General**

The Meriwether County Board of Commissioners reserves the right to waive any requirements or reject any and all bids, to evaluate bids, and to accept any bid that, in its opinion, may be in the best interest of the County.

**Bid Evaluation and Award**

Bids will be evaluated on the basis of the criteria listed and the bid amount.

It is anticipated that a contract for the prescribed services will be entered into with the contractor that in the opinion of the County offers the most favorable combination of qualifications, approach, and pricing.

The County reserves the right to assemble projects in combination awards, if doing so would be in the best interest of the County.

**Contract**

Upon award, the contractor shall enter into a contract with the County for services specified. The contractor shall provide the following with its contract:

- Payment Bond (100%)
- Performance Bond (100%)

**Performance and Approval of Subcontractors**

Sub-consultants and subcontractors must be approved by Meriwether County prior to proceeding with project. All sub-consultants and sub-contractors are subject to the E-Verify and SAVE requirements.

**Conflict of Interest**

The Contractor will certify, along with its subconsultants and subcontractors that, to the best of its knowledge, no circumstances exist which shall cause a conflict of interest in performing services for Meriwether County and that no company other than the bona fide employees working solely for the Contractor has been employed or retained to solicit or secure the contract.

**License, Permits, Taxes**

The Contractor shall be responsible for all licenses, permits, and taxes incurred during the performance of the contract. Permits required by regulatory agencies which are project and site specific shall be paid for by Meriwether County as well as any necessary environmental mitigation costs.

**Changes**

In the event a contract is awarded, the County may at any time during the contract period make changes within the general scope of the contract and its technical provisions. If any such changes cause any increase or decrease in the Contractor's cost of performing any part of the contract, an equitable adjustment shall be made in the Contract price, or

In the time of performance, or both, and a written agreement of such adjustment shall be made prior to proceeding with additional services. No additional services shall be performed until written authorization is received from the County. Nothing in this clause shall excuse the contractor from proceeding with the performance of the contract in accordance with its original terms and conditions and any approved changes.

### **Termination of Contract**

In the event that any of the provisions of this contract are violated by the Contractor, or by any subcontractors, the Owner may serve written notice upon the Contractor and the Surety of its intention to terminate the contract. Such notices shall contain the reasons for such intention to terminate the contract.

If within ten (10) days after such notice upon the Contractor, such violation or delay has not ceased or satisfactory arrangement of corrections have not been made, the contract shall, upon the expiration of said ten (10) days, cease and terminate. In the event of any such termination, the Owner shall immediately serve notice thereof upon the Surety and shall have the right to take over and perform the contract; provided that the Surety does not commence performance thereof within ten (10) days from the date of the mailing to same, to complete by Contractor or by force account and at the expense of the Contractor, the Contractor and his Surety shall be liable to the Owner for any excess cost occasioned the Owner thereby, and in such event the Owner may take possession of and utilize in completing the work, such materials, appliances, and plant as may be on the site of the work and necessary therefore.

### **Contract Period**

The contract period shall be for a period set forth in the contract and any subsequent modifications, which may occur and be mutually agreed upon by both parties.

### **Hold Harmless Agreement**

The Contractor shall agree to defend, indemnify, and hold the County, its officers, agents, and employees harmless from any and all claims made against the County and/or the officers, agents, and employees of the County which relate in any way to this Contract, except for the sole negligence of County. The agreement to hold the County, its officers, agents, and employees harmless shall not be limited to the limits of liability insurance required under provisions of these specifications or the contract, of which these specifications will be made a part.

### **Insurance Requirements**

The Contractor shall secure and maintain for the duration of the contract liability, statutory workers compensation insurance and auto liability insurance coverage. Proof of insurance shall be provided to the County as part of the contract, and the County shall be notified of any changes in insurance coverage status during the contract period. All insurance companies must be licensed to do work in the state of Georgia. The Contractor shall include all subcontractors as insured under its policies or shall furnish separate certificates and endorsements for each subcontractor. All coverage for subcontractors shall be subject to all of the requirements stated herein.

### **Minimum Limits of Insurance**

#### **A. General Liability**

\$1,000,000 General Liability combined single limit per occurrence, for bodily injury, personal injury, and property damage.

#### **B. Automobile Liability**

\$1,000,000 Automobile Liability combined single limit per accident, for bodily injury and property damage, when applicable.

#### **C. Workers Compensation and Employers Liability**

Workers' Compensation shall be provided at the Statutory Minimum as required by State Law.

## **Contractor Affidavit (E-VERIFY)**

The Contractor and any subcontractors will be required to comply with **O.C.G.A. § 13-10-91(B) (1)**- Contractor Affidavit.

## **LAWS AND REGULATIONS**

The Bidder's attention is directed to the fact that all applicable state laws, municipal ordinances and the rules and regulations of all authorities having jurisdiction over construction of the project shall apply to the contract throughout, and they will be deemed to be included in the contract the same as though herein written out in full. Meriwether County in accordance with Title VI of the Civil Rights Act of 1964 and 78 Stat. 252, 42 USC 2000d-part 21, Nondiscrimination in federally assisted programs of the Department of Transportation issued pursuant to such Act, hereby notifies all bidders that it will affirmatively ensure that any contract entered into pursuant to this advertisement, minority business enterprises will be afforded full opportunity to submit bids in response to this invitation and will not be discriminated against on the grounds of race, color, sex, or national origin in consideration for an award.

## **TITLE VI ASSURANCES**

### **1. Compliance with Regulations**

The Contractor shall comply with the regulations relative to nondiscrimination in federally assisted programs of the Department of Transportation (hereinafter referred to as DOT) Title 49, Code of Federal Regulations, part 21, as they may be amended from time to time, (hereinafter referred to as the Regulations), which are herein incorporated by reference and made a part of this contract.

### **2. Nondiscrimination**

The Contractor, with regard to the work performed by it during the contract, shall not discriminate on the grounds of race, color, sex, or national origin in the selection and retention of subcontractors, including procurement of materials and leases of equipment. The Contractor shall not participate either directly or indirectly in discrimination prohibited by Section 21.5 of the Regulations, including employment practices when the contract covers a program set forth in Appendix B of the Regulations.

### **3. Solicitations for Subcontracts, Including Procurement of Materials and Equipment**

In all solicitations either by competitive bidding or negotiations made by Contractor for work to be performed under a subcontract, including procurement of materials or leases of equipment, each potential subcontractor or supplier shall be notified by the Contractor of the Contractor's obligations under this contract and the Regulations relative to nondiscrimination on the ground of race, color, sex, or national origin.

### **4. Information and Reports**

The Contractor shall provide all information and reports required by the Regulations or directives issued pursuant thereto, and shall permit access to its books, records, accounts, other sources of information and its facilities as may be determined by Meriwether County to be pertinent to ascertain compliance with such Regulations, orders, and instructions. Where any information, the Contractor shall so certify to Meriwether County as appropriate and shall set forth what efforts it has made to obtain the information.

### **5. Sanction for Noncompliance**

In the event of the Contractor's noncompliance with the nondiscrimination provisions of this contract, Meriwether County shall impose such contract sanctions as it, the Georgia Department of Transportation or the



Federal Highway Administration may determine to be appropriate, including but not limited to:

- a. Withholding of payments to the Contractor under the contract until the Contractor compiles; and/or
- b. Cancellation, termination, or suspension of the contract, in whole or in part.

**6. Incorporation of Provisions**

The contractor shall include the provisions of paragraphs 1 through 5 in every subcontract, including procurement of materials and leases of equipment, unless exempt by the regulations, or directives pursuant thereto.

**CONFLICT OF INTEREST**

By signing and submitting this contract, I hereby certify that employees of the Company or employees of any Company supplying material or subcontracting to do work on this Contract will not engage in business ventures with employees of Meriwether County, Georgia nor shall they provide gifts, gratuities, favors, entertainment, loans or other items of value to employees of this Department.

**DRUG-FREE WORKPLACE**

The undersigned certifies that the provisions of Code Sections 50-24-1 through 50-24-6 of The Official code of Georgia Annotated, relating to the "Drug-free Workplace Act", have been complied with in full. The undersigned further certifies that:

1. A drug-free workplace will be provided for the Contractor's employees during the performance of the Contract; and
2. Each Contractor who hires a Subcontractor to work in a drug-free workplace shall secure from that Subcontractor the following written certification:

"As part of the Subcontracting Agreement with (Contractor's Name), (Subcontractor's Name) certifies to the Contractor that a drug-free workplace will be provided for the Subcontractors employees during the performance of this Contract pursuant to Paragraph (7) of Subsection B of Code Section 50-24-3."

Also, the undersigned further certifies that he will not engage in the unlawful manufacture, sale, distribution, dispensation, possession, or use of a controlled substance or marijuana during the performance of the Contract.

## 1B PROJECT SCOPE AND DESCRIPTION OF WORK

### 1. Location:

The location of the construction work is:

#### **STRICKLAND TOWN ROAD AT PINEY WOODS CREEK**

### 2. Project Review: A Location Map of the Project is attached.

Meriwether County's responsibilities will include performing official reviews, acquisition of necessary rights of way and easements, and inspection and approval of construction work.

The Contractor shall not begin work until the following have been approved by Meriwether County:

- Environmental documents/permits obtained or satisfactorily addressed
- Erosion and Sedimentation Control Plan
- Traffic Control or detour plan
- Identification of required right of way and construction easements. These shall be acquired by Meriwether County.
- Utility Agreements, Permits or Relocation Plan and/or Contractor Certification of "No Conflict."

### 3. Project Scope:

#### A. Strickland Town Road @ Piney Woods Creek

This project includes the removal and proper disposal of existing culverts and debris, installation of a new box culvert with wing walls, and necessary roadway construction of Strickland Town Road to include base, binder and topping, and restoration of road shoulders impacted by the project.

Hydrology and hydraulic analysis reports are attached and were utilized to determine the culvert size and configuration for this project.

Based on that analysis, Strickland Town Road will require:

- Triple 10' x 8' box culverts with 20% or 1.6 feet embedded in the stream, meeting GDOT Specifications: Number 2403 or 2530P.
- Length: 40 foot
- Wing walls, meeting GDOT specifications 2404 or 2535P shall be constructed at both the inlet and outlet ends of the structure.
- **This contract shall commence upon notice to proceed and extend for a period of 180 days.**

Replacement structure may be precast or poured in place reinforced concrete. If precast units are used, the wingwalls, parapet, and apron must be poured in place and approved by the County.

The reconstructed portion of Strickland Town Road shall have a minimum typical section of 8" GAB, 3" asphalt binder, and 2" asphalt topping, or equivalent structural design, approved by the County, and include centerline and edge line striping.

1C

**PAYMENT FOR WORK PERFORMED**

Payment for the items listed below, complete and accepted, will be made at the lump sum price bid. Payment will be full compensation for performing all work specified.

Partial payments of the lump sum price will be made on monthly statements based on an approved schedule of payments or breakdown of quantities of in place work.

Meriwether County shall retain 10% of the gross value of the completed work, indicated by current estimates until all pay items are substantially completed.

**Company Name:** \_\_\_\_\_

**Date:** \_\_\_\_\_

<b>Road Name</b>	<b>Bid Amount</b>
<b>Strickland Town Road</b>	\$
<b>Project Total</b>	\$

**Meriwether County Board of Commissioners  
Bid Proposal Form**

Installation of Box Culvert and Roadway Construction on Strickland Town Road at Piney Woods Creek

Meriwether County Board of Commissioners  
17234 Roosevelt Highway, Building B.  
Greenville, GA 30222

**Company Name:** \_\_\_\_\_

**Contact Name:** \_\_\_\_\_

**Address:** \_\_\_\_\_

**City, State, Zip:** \_\_\_\_\_

**Telephone:** \_\_\_\_\_ **Fax:** \_\_\_\_\_

**Email:** \_\_\_\_\_

**5% Bid Bond** \_\_\_\_\_ **(Attachment)** \_\_\_\_\_

\_\_\_\_\_  
\_\_\_\_\_  
\_\_\_\_\_

**Major Subcontractor** \_\_\_\_\_  
\_\_\_\_\_

Road Name	Construction
Strickland Town Road	\$
Project Total	\$

Section 2  
BID SCHEDULE

**MADE TO:** **MERIWETHER COUNTY BOARD OF COMMISSIONERS**  
**MERIWETHER COUNTY, GEORGIA**  
**17234 ROOSEVELT HIGHWAY, BUILDING B.**  
**GREENVILLE, GEORGIA 30222**

**PROJECT NAME:** **STRICKLAND TOWN CULVERT**

The undersigned, as Bidder, hereby declares that the only person or persons, company or Parties interested in this bid is or are named herein; and that this bid is made without connection with any other person, company or parties making bid; and that it is in all respects fair and in good faith, without collusion or fraud.

The Bidder further declares that he has carefully examined the site of the work, has read and understands the plans, specifications and contract documents relative thereto, and had read all special provisions and addenda furnished prior to the opening of bids; and the Bidder further declares that he has informed himself fully in regard to all conditions and requirements pertaining to the work.

The Bidder proposes and agrees, if this bid is accepted, to enter into agreement with the Owner in the form of the contract specified and to furnish all labor, tools, equipment and incidentals necessary to complete the work in full and in accordance with the shown, noted, described and reasonably intended requirements of the contract documents. The Contractor shall be responsible for ordering materials in a timely manner to insure no delay in progress of the work. The Contractor shall submit the invoices, tickets or other documentation that may be acceptable to the Owner for their payment.

Bidder accepts all of the terms and conditions of the instructions to bidders, including without limitation those dealing with the disposition of bid security. The Bidder agrees that, at the time of signing the contract, he will furnish the performance bond and payment bond in the forms attached hereto, each in the amount of one hundred percent (100%) of the contract price. Bidder will also furnish all of the required insurance certificates.

The undersigned agrees to furnish all labor, equipment, and materials necessary to complete the work shown, indicated and specified in the plans, specifications and bid schedule. The Owner will reimburse the Contractor for the completed work after suitable documentation is submitted.

Bidder agrees that the Owner has the right to accept or reject any or all bids and to waive all formalities.  
Respectfully submitted,

Date: \_\_\_\_\_

\_\_\_\_\_  
Company

By: \_\_\_\_\_  
Signature

\_\_\_\_\_  
Typed Name

\_\_\_\_\_  
Title

\_\_\_\_\_  
Address

\_\_\_\_\_  
City/State/Zip Code

( ) \_\_\_\_\_  
Telephone

\_\_\_\_\_  
Email

CORPORATE SEAL

**SECTION 3**  
**BID BOND**

KNOW ALL MEN BY THESE PRESENTS, that we \_\_\_\_\_, as Principal, hereinafter Called the Bidder, and \_\_\_\_\_, a corporation duly organized under the laws of The State of \_\_\_\_\_, listed in the latest issue of U.S. Treasury Circular 570, and registered in the State of Georgia, as surety, hereinafter called Surety, are held and firmly bound unto the Meriwether County Board of Commissioners, hereinafter called Owner, as Obligee, in the sum of \_\_\_\_\_ Dollars (in words), (\$ \_\_\_\_\_) (in Figures), for the payment of which sum well and truly to be made, the said Bidder and the said Surety bind Ourselves, our heirs, executors, administrators, successors and assigns, jointly and severally, firmly by these presents.

WHEREAS, the Bidder has submitted a bid for **Removal and proper disposal of existing culverts and debris, installation of box culvert with wing walls, and necessary construction to repair Strickland Town Road.**

NOW THEREFORE, if the Owner shall accept the bid of the Bidder and the Bidder shall enter into a contract with the Owner in accordance with the terms of such bid, and give such bond or bonds as may be specified in the bidding or contract documents with good and sufficient surety for the faithful performance of such contract and for the prompt payment of labor and material furnished in the execution thereof, or in the event of the failure of the Bidder to enter such contract and give such bond or bonds, if the Bidder shall pay the Owner the penalty hereof, then this obligation shall be null and void, otherwise to remain in full force and effect, unless returned by Owner to Bidder; until Owner shall demand payment by Surety, all as allowed in contract documents.

Signed and sealed this \_\_\_\_\_ day of \_\_\_\_\_ 2023

Attest: \_\_\_\_\_ (SEAL)

\_\_\_\_\_ BY

\_\_\_\_\_  
Signature

\_\_\_\_\_  
Printed/Typed Name

\_\_\_\_\_  
Title

Attest: \_\_\_\_\_ (SEAL)

\_\_\_\_\_ BY

\_\_\_\_\_  
Signature

\_\_\_\_\_  
Attorney-in-Fact

\_\_\_\_\_  
Printed/Typed Name

(Attach Certified Copy of Power of Attorney)



**SECTION 4**  
**AGREEMENT/CONTRACT**

THIS AGREEMENT made and entered into the \_\_\_\_\_ day of \_\_\_\_\_ in the year 2023, by and between MERIWETHER COUNTY BOARD OF COMMISSIONERS OF MERIWETHER COUNTY, GEORGIA hereafter called the "Owner," and \_\_\_\_\_ hereinafter called the "Contractor"

WITNESSETH

That the Owner and the Contractor, in consideration of the mutual covenants hereinafter set forth, agree as follows:

The Contractor shall perform all work as specified or indicated in the contract documents for the completion of the project generally described as the **Removal and proper disposal of existing culverts, and debris, installation of box culvert with wing walls and necessary construction to repair Strickland Town Road.**

The Owner shall not be liable to the Contractor for any neglect, default, delay or interference of or by any other contractor, nor shall any such neglect, default, delay or interference or any other contract or alternation which may be required in the work, release the Contractor from the obligation to finish the work within the time allowed.

**OWNER**

The project will be overseen by Meriwether County who is hereinafter called Owner, and who will assume all duties and responsibilities and will have the rights and authority assigned to Owner in the contract documents in connection with completion of the work in accordance with the contract documents.

**CONTRACT TIME**

The Contractor will commence the work required by the contract documents within ten (10) calendar days after the date of the notice to proceed and will complete the within the time frame specified in the Bid Schedule, unless the period for completion is extended otherwise by the contract documents.

## CONTRACT PRICE

The Contractor agrees to perform all the work described in the contract documents and comply with the terms therein for the sum of \_\_\_\_\_ Dollars (in words), (\$ \_\_\_\_\_) (in figures), and/or as shown in the Bid Schedule.

### Contract Documents consist of the following:

- 1) Cost Proposal (Information & Instructions, Project Scope and Description of Work, Measurement & Payment, Proposal Form);
- 2) Bid Schedule;
- 3) Bid Bond;
- 4) Agreement/Contract;
- 5) Performance Bond;
- 6) Payment Bond;
- 7) Contractor & Sub-Contractors Affidavit (E-Verify)'
- 8) General Conditions;
- 9) Insurance Documentation
- 10) Attachments

## PAYMENTS

It is hereby mutually agreed that the Owner is to pay and the Contractor is to receive the price bid in the proposal herein contained, or hereto annexed, as full compensation for furnishing all materials, testing, quality control, supplies, machinery, equipment, tools apparatus and other means of construction, maintenance and repairs, and all management, supervision, and labor, and perform all construction maintenance and repair necessary to complete the work under the conditions herein specified and for fully complying with the terms and conditions of this contract, provided that any increased cost to the Contractor due to any subsequent levy of Federal or State tax against any item entering into the work of this contract exclusive of profits, may be reimbursed to the Contractor by the Owner as provided hereunder.

## PROGRESS AND FINAL PAYMENTS

Owner shall make progress payments on account of the contract price on the basis of the Contractor's application for payment as approved by the Owner's representative, within **thirty (30)** days following receipt of approved request during construction. All progress payments will be on the basis of the progress of work, less 10% retainage.

## MISCELLANEOUS

- A. Terms used in this agreement/contract are defined in the general conditions and shall have the meanings described therein.
- B. Neither Owner nor Contractor shall, without the prior written consent of the other, assign or sublet in whole or in part his interest under any of the contract documents, specifically.
- C. Owner and Contractor each binds himself, his partners, successors, assigns and legal representatives, to the other part hereto in respect to all covenants, agreements and obligations contained in the contract documents.
- D. Contract documents constitute the entire agreement/contract between Owner and Contractor and may be altered, amended or repealed only by the duly executed written instrument, in the form of a change order.

Contractor shall not assign any monies due or to become due without the prior written consent of the Owner.

IN WITNESS WHEREOF, the parties hereto have executed this agreement/contract the day and year first above written. The Chairman shall execute this agreement/contract the same being recorded in Minutes of the Meeting of Meriwether County Board of Commissioners dated \_\_\_\_\_.

IN WITNESS WHEREOF, this instrument is executed in three (3) counterparts, each one of which shall be deemed an original.

\_\_\_\_\_  
**CONTRACTOR**

\_\_\_\_\_  
**OWNER**

\_\_\_\_\_  
**Signature**

\_\_\_\_\_  
**Signature**

\_\_\_\_\_  
**Printed/Typed Name**

\_\_\_\_\_  
**Printed/Typed Name**

\_\_\_\_\_  
**Title**

\_\_\_\_\_  
**Title**

\_\_\_\_\_  
**Date**

\_\_\_\_\_  
**Date**

**Attest:**

**Attest:**

**By** \_\_\_\_\_  
**Secretary**

**By** \_\_\_\_\_  
**Clerk**

**(Seal)**

**Approved As To Form:**

\_\_\_\_\_  
**Attorney, Meriwether County**

**SECTION 5**  
**PERFORMANCE BOND**

KNOW ALL MEN BY THESE PRESENTS, that we \_\_\_\_\_ as Principals, hereinafter called Contractor, and \_\_\_\_\_, a corporation duly organized under the laws of the State of \_\_\_\_\_, listed in the latest issue of U.S. Treasury Circular 570, and registered in the State of Georgia as Surety, are held and firmly bound unto Meriwether County Board of Commissioners of Meriwether County, Georgia, hereinafter called Owner, in the sum of \_\_\_\_\_ Dollars (in words), (\$ \_\_\_\_\_) (in figures), for payment of which sum, well and truly to be made, the Contractor and Surety bind themselves, their heirs, executors, administrators, successors and assigns, jointly and severally, firmly by these presents.

WHEREAS, the Contractor has entered into a written contract dated \_\_\_\_\_ with Owner for **Removal and proper disposal of existing culverts and debris, installation of box culvert with wing walls, and necessary construction to repair Strickland Town Road.** In accordance with the Bid Document and specifications prepared and issued by Meriwether County which contract is by reference made a part hereof and is hereinafter referred to as the Contract.

NOW THEREFORE, THE CONDITION OF THE OBLIGATION is such that, if Contractor shall promptly and faithfully perform said Contract, then this obligation shall be null and void otherwise shall remain in full force and effect. The Surety hereby waives notice of any alteration or extension of time made by the Owner. Whenever Contractor shall be, and declared by Owner to be in default under the Contract, the Owner having performed Owner's obligations there under, the Surety may promptly remedy the default, or shall promptly:

1. Complete the Contract in accordance with its terms and conditions; or,
2. Obtain a bid for completing the Contract in accordance with its terms, and conditions, and upon determination by Surety of the lowest responsible bidder, or, if the Owner elects, upon determination by the Owner and the Surety jointly of the lowest responsible Bidder, arrange for a contract between such Bidder and Owner, and make available as work progresses (even though there should be default or a succession of defaults under the contract or contracts of completion arranged under this paragraph including other cost and damages for which the Surety may be liable hereunder, the amount set forth in the first paragraph hereof). The term "balance of the contract price", as used in this paragraph, shall mean the total amount payable by Owner to Contractor under the contract and any amendments thereto, less the amount properly paid by Owner or Contractor.

Any suit under this Bond must be instituted before expiration of two (2) years from the date on which final payment under the Contract falls due.

No right of action shall accrue on this Bond to or for the use of any person or corporation other than the Owner named herein or the heirs, executors, administrators or successors of the Owner.

**IN WITNESS WHEREOF**, this instrument is executed in three (3) counterparts, each on of which shall be deemed an original, this \_\_\_\_\_ day of \_\_\_\_\_, 2023.

Attest:

\_\_\_\_\_

BY

\_\_\_\_\_  
Principal (Bidder) (SEAL)

\_\_\_\_\_  
Signature

\_\_\_\_\_  
Printed/Typed Name

Attest:

\_\_\_\_\_

BY

\_\_\_\_\_  
Surety (SEAL)

\_\_\_\_\_  
Signature  
Attorney-in-Fact

(Attach Certified Copy of Power of Attorney)

**SECTION 6**  
**PAYMENT BOND**

KNOW ALL MEN BY THESE PRESENTS, that we \_\_\_\_\_ as Principal, hereinafter called Contractor, and \_\_\_\_\_, a corporation duly organized under the laws of the State of \_\_\_\_\_, listed in the latest issue of U.S. Treasury Circular 570, and registered in State of Georgia, as surety, are held and firmly bound unto Meriwether County Board of Commissioners of Meriwether County, Georgia, hereinafter called Owner, in the sum of \_\_\_\_\_ dollars (in words), (\$ \_\_\_\_\_) (in figures), for the payment of which sum, well and truly to be made, the Contractor and Surety bind themselves, their heirs, executors, administrators, successors and assigns, jointly and severally, firmly by these presents.

WHEREAS, the Contractor has entered into a written contract dated \_\_\_\_\_ with the Owner for **Removal and proper disposal of existing culverts and debris, installation of box culvert with wing walls, and necessary construction to repair Strickland Town Road** in accordance with bid documents and specifications prepared or issued by Meriwether County which contract is by reference made a part hereof, and is hereinafter referred to as the Contract.

NOW THEREFORE, THE CONDITION OF THIS OBLIGATION is such that, if Contractor shall promptly make payment to all claimants as hereinafter defined, for all labor and material used or reasonably required for use in the performance of the Contract, then this obligation shall be void; otherwise it shall remain in full force and effect, subject however, to the following conditions:

- A. A claimant is defined as one having direct contract with the Contractor or with a Subcontractor of the Contractor for equipment, labor, and material used or reasonably required for use in the performance of the Contract, labor, equipment, and material being construed to include that part of water, gas, power, light, heat, oil, gasoline, telephone service or rental of equipment directly applicable to the Contract.
- B. The above named Contractor and Surety hereby jointly and severally agree with the Owner that every claimant as herein defined, who has not been paid in full before the expiration of a period of ninety (90) days after the date on which the last of such claimant's work or labor was done or performed, or materials, may prosecute the suit to final judgement for such sums or sums as may be justly due claimant, and have execution thereon. The Owner shall not be liable for the payment of any costs or expense of any such suit.
- C. No suit or action involving payment shall be commenced hereunder by any claimant,
  1. Unless claimant, other than one having a direct contract with the Contractor, shall have given written notice to any two of the following: the Contractor, the Owner, or the Surety named above, within ninety (90) days after such claimant did or performed the last of the work of labor, or furnished the last of the materials for which said claim is made, stating with substantial accuracy the amount claimed and the name of the party to whom the materials were furnished or for whom the work of labor was done or performed. Such notice shall be served by mailing the same by registered mail or certified mail, postage prepaid, in an envelope addressed to the Contractor, Owner or Surety, at any place where any office is regularly maintained for the transaction of business, or served in any manner in which legal process may be served in the state in which the aforesaid project is located, save that such service need not be made by a public officer.
  2. After one (1) year from the completion of Contract and the acceptance by Owner of the work there under, it being understood, however, that if any limitation embodied in this bond is prohibited by any law controlling the

construction hereof such limitation shall be deemed to be amended so as to be equal to the minimum period of limitation permitted by such law.

3. Other than in the Superior Court of Meriwether County.
4. The amount of this bond shall be reduced by and to the extent of any payment of payments made in good faith hereunder, inclusive of the payment by surety of mechanics' liens which may be filed on record against said improvement, whether or not claim for the amount of such presented under and against this bond.

IN WITNESS WHEREOF, this instrument is executed in three (3) counterparts, each one of which shall be deemed an original, this \_\_\_\_\_ day of \_\_\_\_\_, 20\_\_\_\_\_.

Attest:

\_\_\_\_\_  
Principal (Bidder) (SEAL)

BY

\_\_\_\_\_  
Signature

\_\_\_\_\_  
Typed Name

\_\_\_\_\_  
Title

Attest:

\_\_\_\_\_  
Surety (SEAL)

BY

\_\_\_\_\_  
Signature  
Attorney-in-Fact

\_\_\_\_\_  
Typed Name

(Attached Certified Copy of Power of Attorney)



**SECTION 7**  
**Contractor Affidavit under O.C.G.A. § 13-10-91(b) (1)**

By executing this affidavit, the undersigned contractor verifies its compliance with O.C.G.A. § 13-10-91, stating affirmatively that the individual, firm or corporation which is engaged in the physical performance of services on behalf Meriwether County, Georgia has registered with, is authorized to use and uses the federal work authorization program commonly known as E-Verify, or any subsequent replacement program, in accordance with the applicable provisions and deadlines established in O.C.G.A. § 13-10-91. Furthermore, the undersigned contractor will continue to use the federal work authorization program throughout the contract period and the undersigned contractor will contract for the physical performance of services in satisfaction of such contract only with subcontractors who present an affidavit to the contractor with the information required by O.C.G.A. § 13-10-91(b). Contractor hereby attests that its federal work authorization user identification number and date of authorization are as follows:

\_\_\_\_\_  
**Federal Work Authorization User Identification Number**

\_\_\_\_\_  
**Date of Authorization**

\_\_\_\_\_  
**Name of Contractor**

\_\_\_\_\_  
**Name of Project**

\_\_\_\_\_  
**Name of Public Employer**

I hereby declare under penalty of perjury that the foregoing is true and correct.

Executed on \_\_\_\_\_, \_\_\_\_\_, 2023 in \_\_\_\_\_ (city), \_\_\_\_\_ (state).

\_\_\_\_\_  
**Signature of Authorized Officer or Agent**

\_\_\_\_\_  
**Printed Name and Title of Authorized Officer or Agent**

**SUBSCRIBED AND SWORN BEFORE ME**

**ON THIS THE \_\_\_\_\_ DAY OF \_\_\_\_\_, 20\_\_.**

\_\_\_\_\_  
**NOTARY PUBLIC**

**My Commission Expires: \_\_\_\_\_**

**Subcontractor Affidavit under O.C.G.A. § 13-10-91(b) (3)**

By executing this affidavit, the undersigned subcontractor verifies its compliance with O.C.G.A. § 13-10-91, stating affirmatively that the individual, firm or corporation which is engaged in the physical performance of services under a contract with (name of contractor) on behalf of Meriwether County, Georgia has registered with, is authorized to use and uses the federal work authorization program commonly known as E-Verify, or any subsequent replacement program, in accordance with the applicable provisions and deadlines established in O.C.G.A. § 13-10-91. Furthermore, the undersigned subcontractor will continue to use the federal work authorization program throughout the contract period and the undersigned subcontractor will contract for the physical performance of services in satisfaction of such contract only with sub-subcontractors who present an affidavit to the subcontractor with the information required by O.C.G.A. § 13-10-91(b). Additionally, the undersigned subcontractor will forward notice of the receipt of an affidavit from a sub-subcontractor to the contractor within five business days of receipt. If the undersigned subcontractor receives notice that a sub-subcontractor has received an affidavit from any other contracted sub-subcontractor, the undersigned subcontractor must forward, within five business days of receipt, a copy of the notice to the contractor. Subcontractor hereby attests that its federal work authorization user identification number and date of authorization are as follows:

\_\_\_\_\_  
Federal Work Authorization User Identification Number

\_\_\_\_\_  
Date of Authorization

\_\_\_\_\_  
Name of Subcontractor

\_\_\_\_\_  
Name of Project

\_\_\_\_\_  
Name of Public Employer

I hereby declare under penalty of perjury that the foregoing is true and correct.

Executed on \_\_\_\_\_, \_\_\_\_\_, 2023 in \_\_\_\_\_ (city), \_\_\_\_\_ (state).

\_\_\_\_\_  
Signature of Authorized Officer or Agent

\_\_\_\_\_  
Printed Name and Title of Authorized Officer or Agent

SUBSCRIBED AND SWORN BEFORE ME  
ON THIS THE \_\_\_\_\_ DAY OF \_\_\_\_\_, 20\_\_.

\_\_\_\_\_  
NOTARY PUBLIC

My Commission Expires: \_\_\_\_\_

**Sub-subcontractor Affidavit under O.C.G.A. § 13-10-91(b) (4)**

By executing this affidavit, the undersigned sub-subcontractor verifies its compliance with the O.C.G.A. § 13-10-91, stating affirmatively that the individual, firm or corporation which is engaged in the physical performance of services under a contract for (name of subcontractor or sub-subcontractor with whom such sub-subcontractor has privity of contract) and (name of contractor) on behalf of Meriwether County, Georgia has registered with, is authorized to use and uses the federal work authorization program commonly known as E-Verify, or any subsequent replacement program, in accordance with the applicable provisions and deadlines established in O.C.G.A. § 13-10-91. Furthermore, the undersigned sub-subcontractor will continue to use the federal work authorization program throughout the contract period and the undersigned sub-subcontractor will contract for the physical performance of services in satisfaction of such contract only with sub-subcontractors who present an affidavit to the sub-subcontractor with the information required by O.C.G.A. § 13-10-91(b). The undersigned sub-subcontractor shall submit, at the time of such contract, this affidavit to (name of subcontractor or sub-subcontractor with whom such sub-subcontractor has privity of contract). Additionally, the undersigned sub-subcontractor will forward notice of the receipt of any affidavit from a sub-subcontractor to (name of subcontractor or sub-subcontractor with whom such sub-subcontractor has privity of contract). Sub-subcontractor hereby attests that its federal work authorization user identification number and date of authorization are as follows:

\_\_\_\_\_  
Federal Work Authorization User Identification Number

\_\_\_\_\_  
Date of Authorization

\_\_\_\_\_  
Name of Sub-subcontractor

\_\_\_\_\_  
Name of Project

\_\_\_\_\_  
Name of Public Employer

I hereby declare under penalty of perjury that the foregoing is true and correct.

Executed on \_\_\_\_\_, \_\_\_\_\_, 2023 in \_\_\_\_\_ (city), \_\_\_\_\_ (state).

\_\_\_\_\_  
Signature of Authorized Officer or Agent

\_\_\_\_\_  
Printed Name and Title of Authorized Officer or Agent

SUBSCRIBED AND SWORN BEFORE ME  
ON THIS THE \_\_\_\_\_ DAY OF \_\_\_\_\_, 2023.

\_\_\_\_\_  
NOTARY PUBLIC  
My Commissioner Expires: \_\_\_\_\_

**SECTION 8**  
**GENERAL CONDITIONS**

**PART 1 – GENERAL INFORMATION**

**008.1.01. DEFINITIONS OF WORDS AND TERMS**

Where used in these general conditions or in the other contract documents, the following words and terms shall have the meanings indicated. The meanings shall be applicable to the singular, plural, masculine and feminine of the words and terms.

**Acceptance.** Formal action of the Owner in determining that the Contractor's work has been completed in accordance with the contract and in notifying the Contractor in writing of the acceptability of the work.

**Act of God.** Cataclysmic phenomenon of nature, such as an earthquake, flood or cyclone. Rain, wind, high water, or other natural phenomenon, which might reasonably have been anticipated from historical records of the general locality of the work, shall not be construed as Acts of God.

**Addenda.** Supplemental written specifications or drawings issued prior to execution of the contract which modify or interpret the contract documents by addition, deletion, clarification, or corrections.

**Bid.** Offer of a Bidder submitted on the prescribed form setting forth the price or prices of the work to be performed.

**Bidder.** Individual, partnership, corporation or a combination thereof, includes joint ventures, offering a bid to perform the work.

**Contract Documents.** The Agreement, Addenda (which pertain to the Contract Documents), Contractor's Bid (including documentation accompanying the bid and any post-bid documentation submitted prior to the Notice of Award) when attached as an exhibit to the Agreement, the Bonds, these General Conditions, the Supplementary Conditions, the Specifications, the Drawings as the same are more specifically identified in the Agreement, together with all modifications issued after the execution of the Agreement.

**Contract Price.** Amount payable to the Contractor under the terms and conditions of the contract, based on the price given on the bid schedule, with adjustments made in accordance with the contract. The base amount given in the bid schedule shall be either a lump sum or the summation of the unit price bids multiplied by the estimated quantities set forth in the bid form.

**Contract Time.** Number of calendar days stated in the contract for the completion of the work portions thereof.

**County.** The Meriwether County Board of Commissioners

**Day.** Calendar Day

**Direct.** Action of the Owner by which the Contractor is ordered to perform or refrain from performing work under the contract.

**Directive.** Written documentation of the action or actions of the Owner in directing the Contractor.

**Equipment.** Mechanical, electrical, instrumentation or any other device with one or more moving parts, or devices requiring an electrical, pneumatic, electronic or hydraulic connection.

**Furnish.** To deliver to the job site or other specified location any item, equipment or material.

**Install.** Placing, erecting or constructing complete in place any item, equipment or material.

**May.** Refers to permissive actions.

**Owner.** The Meriwether County Board of Commissioners

**Owner's Representative.** The person designated in writing by the Owner to act as its agent on specified matters relating to this contract.

**Person.** The term, person, includes firms, companies, corporations, partnerships and joint ventures.

**Project.** The work as a whole under this contract, including all labor, excavation and grading, pipeline construction, structures, etc. and all other items included in the contract documents.

**Provide.** Furnish and install, complete in place.

**Shall.** Refers to actions by either the Contractor or the Owner and means the Contractor or the Owner has entered into a covenant with the other party to do or perform the action.

**Shown.** Refers to information presented or indicated on the drawings, with or without reference to the drawings.

**Specify.** Refers to information described, shown, noted or presented in any manner in any part of the contract.

**Will.** Refers to actions entered into by the Contractor or the Owner as a covenant with the other party to do or to perform the action.

**Work.** The labor, materials, equipment, supplies, services and other items necessary for the execution, completion and fulfillment of the contract.

## **008.1.02. CONTRACT AND CONTRACT DOCUMENTS**

The contract documents as enumerated in Section 4 of the Agreement/Contract shall form this contract and the provisions thereof and shall be as binding upon the parties hereto as if they were herein fully set forth. The table of contents, titles, headings, running headlines and marginal notes contained herein and in said documents are solely to facilitate reference to various provisions of the contract documents and in no way affect, limit, or cast light on the interpretation of the provision to which they refer.

Any provision in any of the contract documents which may be in conflict or inconsistent with any of the paragraphs in these general conditions shall be void to the extent of such conflict or inconsistency.

## **008.1.03. Guaranty**

Neither the final certificate of payment nor any provision in the contract documents nor partial or entire occupancy or the premises by the Owner shall constitute an acceptance of work not done in accordance with the contract documents nor shall they relieve the Contractor of liability in respect to any expressed warranties or responsibility for faulty materials or workmanship. The following to the Contractor's Guaranty apply:

A. All structures erected under this contract shall be fully guaranteed by the Contractor for a period of one (1) year from the date of final inspection and acceptance by the Owner.

This guarantee shall cover any and all defects in workmanship or materials that may develop in this specified time, and any failure in such workmanship or materials shall be repaired or replaced to the satisfaction of the Owner by the Contractor at his own expense.

B. All equipment of whatever nature incorporated in the work covered by this Contract shall carry the same guarantee as outlined above for construction. Failure of any equipment or part thereof within the specified time shall be corrected to the satisfaction of the Owner, at the Contractor's expense. This guarantee does not apply to manufacturing defects of equipment furnished by the Owner.

C. It is the intent of these provisions that all/or culverts, pipe, etc. (both underground and above ground), together with all appurtenances attached thereto, under this contract, shall be classified as structures.

The Owner will give notice of observed defects with reasonable promptness. In the event that the Contractor should fail to make such repairs, adjustments, or other work that may be necessary by such defects, the Owner may do so and charge the Contractor the cost thereby incurred.

The performance bond shall remain in full force and effect through the guarantee period. Any provision in any of the contract documents which may be in conflict or inconsistent with any of the paragraphs in these general conditions, shall be void to the extent of such conflict or inconsistency.

**008.1.04.****RIGHT OF THE OWNER TO TERMINATE CONTRACT**

In the event that any of the provisions of this contract are violated by the Contractor, or by any of his subcontracts, the Owner may serve written notice upon the Contractor and the Surety of its intention to terminate the contract, such notices to contain the reasons for such intention to terminate the contract and, unless within ten (10) days after the serving of such notice upon the Contractor, such violation or delay shall cease and satisfactory arrangement of correction be made, the contract shall, upon the expiration of said ten (10) days, cease and terminate. In the event of any such termination, the Owner shall immediately serve notice thereof upon the Surety and shall have the right to take over and perform the contract; provided, however, that if the Surety does not commence performance thereof within ten (10) days from the date of the mailing to same to complete by Contractor or by force account and at the expense of the Contractor, the Contractor and his Surety shall be liable to the Owner for any cost occasioned the Owner thereby, and in such event the Owner may take possession of and utilize in completing the work, such materials, appliances, and plant as may be on the site of the work and necessary therefore. Any costs incurred by Owner in causing contractor's work to be completed in accordance with the terms of this agreement shall be the responsibility of Contractor.

**008.1.05.****PAYMENTS TO CONTRACTOR**

The owner shall make a progress payment of not more than one payment per month to the Contractor on the basis of a duly certified and approved estimate of the work performed during the preceding calendar month to insure the proper performance of this Contract. The Owner shall retain ten percent (10%) of the amount of each estimate until final completion and acceptance of all work covered by this contract.

- A. In preparing estimates, the material delivered on the site and preparatory work done may be taken into consideration.
- B. The project name and project number shall be shown on all invoices and correspondence.
- C. All material and work covered by partial payments made shall thereupon become the sole property of the Owner, but this provision shall not be construed as relieving the Contractor from the sole responsibility for the care and protection of materials and work upon which payments have been made, or the restoration of any damaged work, or as a waiver of the Owner to require the fulfillment of all terms of the contract.
- D. The Contractor agrees that he will indemnify and save the Owner harmless from all claims growing out of the lawful demands of subcontractors, laborers, workmen, mechanics, material men, and furnishers of machinery and parts thereof, equipment, power tools and all supplies, including commissary, incurred in the furtherance of the performance of this Contract. The Contractor shall, at the Owner's request, furnish satisfactory evidence (Interim Waiver and Release form) that all obligations of the nature hereinabove designated have been paid, discharged, or waived. If the Contractor fails so to do, then the Owner may, after having served written notice on the said Contractor, either pay unpaid bills of which the Owner has written notice direct, or withhold from the Contractor's unpaid compensation a sum of money deemed reasonably sufficient to pay any and all such lawful claims until satisfactory evidence is furnished that all liabilities have been fully discharged whereupon payment to the Contractor shall be resumed in accordance with the terms of this contract, but in no event shall the provisions of this sentence be construed to impose any obligations upon the Owner to either the Contractor or his Surety, in paying any unpaid bills of the Contractor. The Owner shall be deemed the agent of the Contractor and the Owner shall not be liable to the Contractor for any such payments made in good faith.

E. The Contractor, before submittal of the final pay request, shall submit an up to date "RECORD" set of drawings if the work is revised from the original plans and approved by the Owner's representative. Payment will be withheld until these documents are submitted.

All "Record Drawings" shall be accurate and legible, depicting to the best of the Contractor's ability, all materials or equipment, actually in place as specified in the approved revisions. The drawings shall contain all appropriate locations, dimensions, depths, stations, offset distances, etc., and all applicable easements.

#### **008.1.06. PAYMENTS BY CONTRACTOR**

The Contractor shall pay for all transportation and utility services not later than the twentieth (20<sup>th</sup>) day of the calendar month following that in which services are rendered, and for all materials, tools and other expendable equipment to the extent of ninety percent (90%) of the cost thereof, not later than the twentieth (20<sup>th</sup>) day of the calendar month following that in which such materials, tools and equipment are delivered at the site of the project, and the balance of the cost thereof, not later than the thirtieth (30<sup>th</sup>) day following the completion of that part of the work in or on which such materials, tools and equipment are incorporated or used, and to each of his subcontractors, not later than the fifth (5<sup>th</sup>) day following each payment to the Contractor, the respective amount allowed to the Contractor on account of the work performed by his subcontractors the extent of each subcontractor's interest therein.



## **008.1.07. LAWS, REGULATIONS AND PERMITS**

### **A. GENERAL**

The Contractor shall give the notices required by law and comply with all laws, ordinances, rules and regulations pertaining to the conduct of the work. The Contractor shall be liable for violations of the law in connection with work provided by the Contractor. If the Contractor observes that the contract documents, drawings or specifications are at variance with any laws, ordinances, rules or regulations, he shall promptly notify the Owner in writing of such variance. The Owner shall promptly review the matter and, if necessary, shall issue a change order or take any other action necessary to bring about compliance with the law, ordinance, rule or regulation in question. Contractor agrees not to perform work known to be contrary to any laws, ordinances, rules and regulations.

### **B. PERMITS AND LICENSES**

Unless otherwise specified herein, permits and licenses from governmental agencies which are necessary only for and during the prosecution of the work and the subsequent guarantee period shall be secured and paid for by the Contractor. Permits and licenses of regulatory agencies which are necessary to be maintained after completion of the guarantee period shall be paid for by the Owner.

### **C. PAYMENTS AND ROYALTIES**

The costs involved in fees, royalties or claims for any patented invention, article process or method that may be used upon or in a manner connected with the work under this contract or with the use of completed work by the Owner, shall be paid by the Contractor. The Contractor and his sureties shall protect and hold the Owner and The Owner's representative together with their officers, agents and employees, harmless from any and all loss, defense cost, and expenses against any and all demands made for such fees or claims brought or made by the holder of any invention or patent. Before final payment is made on the account of this contract, the Contractor shall, if requested by the Owner, furnish acceptable proof of a proper release from all such fees or claims.

Should the Contractor, his agent, employee or any of them be enjoined from furnishing or using any invention, article, material or plans supplied or required to be supplied or used under this contract, the Contractor shall promptly pay such royalties and secure the requisite licenses; or, subject to acceptance by the Owner, substitute other articles, materials or appliances in lieu thereof which are of equal efficiency, quality, finish, suitability and market value to those planned or required under the contract. Descriptive information of these substitutions shall be submitted to the Owner for determination of general conformance to the design concept and the construction contract. Should the Owner elect to refuse the substitution, the Contractor agrees to pay such royalties and secure such valid licenses as may be requisite for the Owner, his officers, agents and employees or any of them, to use such invention, article, material or appliance without being disturbed or in any way interfered with by and proceeded in law or equity on account thereof.

## **008.1.08. TIME FOR COMPLETION**

It is hereby understood and mutually agreed, by and between the Contractor and the Owner, that the date of beginning and the time for completion as specified in the contract of the work to be done hereunder are **essential conditions** of this contract.

The Contractor agrees that said work shall be prosecuted regularly, diligently and uninterruptedly at such rate of progress as will ensure full completion thereof within the time specified. It is expressly understood and agreed, by and between the Contractor and the Owner, that the time for the completion of the work described herein is a reasonable time for the completion of the projects.

It is further agreed that time is of the essence of this contract and of the specification wherein a definite and certain length of time is fixed for the performance under the contract. If additional time is necessary for the completion of any work, the new time limit shall be fixed by an extension approved by Owner.

#### **008.1.09. CHANGES IN WORK**

##### **A. GENERAL**

Whenever the Contractor is directed to perform extra work on a time and expense basis, he will maintain accurate records. Each day a record of labor, materials and equipment costs will be submitted to the Owner's representative for verification. These records will reflect the actual and necessary expenses pertaining to the extra work and shall be available for audit. Audits conducted under this provision shall be in accordance with generally accepted auditing standards and established procedures and guidelines of the reviewing or audit agency.

In determining time and expense compensation, the term "actual necessary expense" shall mean the sum of (1) materials and equipment, (2) labor, (3) supervision, (4) construction equipment, (5) professional services and (6) other costs. Charges for such items shall mean the actual cost whether incurred by the Contractor, a subcontractor or others.

#### **008.1.10. CORRECTON OF WORK**

All work, all materials, whether incorporated in the work or not, and all processes of manufacture shall be at all times and places subject to the inspection of the Owner's representative who shall be the final judge of the quality and suitability of the work, materials, and processes. Should they fail to meet Owner's approval they shall be forthwith reconstructed, made good, replaced and/or corrected, as the case may be, by the Contractor at his own expense. Rejected material shall immediately be removed from the site.

#### **008.1.11. ADDITIONAL WORK OR CHANGES**

Without invalidating the Contract, the Owner may order additional work or make changes by altering, adding to or deducting from the work, the Contract sum being adjusted accordingly, and the consent of the Surety being first obtained where necessary or desirable.

No claim for extra work or cost shall be allowed unless the same was done in pursuance of a written order and approved by the Owner, as aforesaid, and the claim presented with the first estimate after the changed or extra work is done. When work is performed under the terms of the General Conditions, the Contractor shall furnish satisfactory bills, payrolls, and vouchers covering all items of cost, and when requested by the Owner's representative, give the Owner access to accounts relating thereto.

## **PART II - SPECIFICATIONS**

### **008.2.01. UTILITIES**

It shall be the responsibility of the Contractor to determine the exact location of existing utilities and service connections thereto. The Contractor shall make his own investigations, including exploratory excavations, to determine the locations and type of existing utilities, including service connections, prior to commencing work, which could result in damage to such utilities.

The contractor shall comply with the Georgia Utility Facility Protection Act and contact the Utilities Protection Center at 1-800-282-7411 for the purpose of coordinating and marking underground utilities.

### **008.2.02. ADDITIONAL INSTRUCTIONS AND DETAIL DRAWINGS**

The Contractor will be furnished any additional instructions and drawings as necessary to carry out the work included in the Contract. The additional drawings and instructions thus supplied to the Contractor will coordinate with the contract documents and will be so prepared that they can be reasonably interpreted as part thereof. The Contractor shall carry out the work in accordance with the additional detail drawings and instructions.

### **008.2.03. MATERIALS, SERVICES AND FACILITIES**

#### **A. GENERAL**

It is understood that except as otherwise specifically stated in the contract documents, the Contractor shall provide and pay for all materials, labor, tools, equipment, water, light, power, transportation, superintendence, and temporary construction of every nature whatsoever necessary to execute, complete and deliver the work within the specified time.

Any work to be performed after regular working hours, shall be performed without additional expense to the Owner.

### **008.2.04. CONTRACTOR'S TITLE TO MATERIALS**

No materials or supplies for the work shall be purchased by the Contractor or by any subcontractor subject to any chattel mortgage, or under a conditional sale contract or other agreement by which an interest is retained by the seller. The Contractor warrants that he has good title to all materials and supplies used by him in the work, free from all liens, claims or encumbrances.

### **008.2.05. INSPECTION AND TESTING OF MATERIALS**

A. All materials and equipment used in the construction of the project shall be subject to adequate inspection and testing in accordance with accepted standards.

B. Materials of construction, particularly those upon which the strength and durability of the structure may depend, shall be subject to inspection and testing to establish conformance with specifications and suitability for uses intended.

C. Quality Control / Quality Assurance (QC/QA) shall be performed by the contractor in cooperation with a qualified testing firm. Sampling and testing shall be done in accordance with the GDOT specifications. No separate payment will be made for QC/QA, sampling and testing.

**008.2.06. WEATHER CONDITIONS**

In the event of temporary suspension of work, or during inclement weather, or whenever the Owner shall direct, the Contractor will and shall cause his subcontractors to protect carefully his and their work and materials against damage or injury from the weather. If, in the opinion of the Owner, any work or materials shall have been damaged or injured by reason of failure on the part of the Contractor or any of his subcontractors so to protect his work, such materials shall be removed and replaced at the expense of the Contract.

**008.2.07. INSPECTIONS**

The authorized representatives and agents of the Owner shall be permitted to observe all work, materials, payrolls, and records of personnel, invoices of materials and other relevant data and records.

**008.2.08. REPORTS, RECORDS AND DATA**

The Contractor shall submit to the Owner such schedule of quantities and costs, progress schedules, payrolls, reports, estimates, records and other data as the Owner may request concerning work performed or to be performed under this contract.

**PART III – CONTRACTOR’S RESPONSIBILITIES**

**008.3.01 CONTRACTOR’S OBLIGATIONS**

The Contractor shall and will, in good workmanlike manner, do and perform all work and furnish all supplies and materials, machinery, equipment, facilities and means, except as herein specified, in accordance with the provisions of this contract and specifications, and in accordance with the plans and drawings, and in accordance with the directions of the Owner as given from time to time during the progress of the work. He shall furnish, erect, maintain, and remove such construction plant and such temporary works as may be required.

The constructor shall observe, comply with, and subject to all terms, conditions, requirements, and limitations of the contract and specifications, and shall do, carry on, and complete the entire work to the satisfaction of the Owner.

**008.3.02. PROTECTION OF WORK AND PROPERTY**

The Contractor shall, at all times safely guard the Owner’s property from injury or loss in connection with this contract. He shall at all times safely guard and protect his own work, and that of adjacent property, from damage. The Contractor shall replace or make good any such damage, loss or injury unless caused directly by errors contained in the contract, or by the Owner, or its duly authorized representatives.

In case of an emergency, which threatens loss or injury of property, and/or safety of life, the Contractor will be allowed to act without previous instructions from the Owner, in a diligent manner. He shall notify the Owner immediately thereafter. Any claim for compensation by the Contractor due to such extra work shall be promptly submitted to the Owner for approval.

Where the Contractor has not taken action but has notified the Owner of an emergency threatening injury to persons or damage to the work or any adjoining property, he shall act as instructed or authorized by the Owner.

#### **008.3.03. SUPERINTENDENCE BY CONTRACTORS**

At the site of the work, the Contractor shall employ a construction superintendent or foreman, who shall have full authority to act for the Contractor. It is understood that such representative shall be acceptable to the Owner and shall be one who can be continued in that capacity for the particular job involved, unless he ceases to be on the Contractor's payroll.

#### **008.3.04. MUTUAL RESPONSIBILITY OF CONTRACTORS**

If, through acts of neglect on the part of Contractor, any subcontractor shall suffer loss or damage on the work, the Contractor agrees to settle with such subcontractor by agreement or arbitration, if subcontractor will so settle. If subcontractor assesses any claim against the Owner on account of any damage alleged to have been sustained, the Owner shall notify the Contractor who shall indemnify and save harmless the Owner against any such claim.

Contractor shall defend, indemnify and hold harmless the Owner, their respective successors and assigns and their respective officers, employees and agents (collectively referred to as the "Indemnitees"), and each of them, from and against any and all claims, liabilities, damages, fines, penalties or costs of any nature (including reasonable attorney's fees) resulting in death of or injury to any person or loss of or damage to any property, arising out of or in any way related to the Work, except to the extent caused by the negligence of indemnitees. This indemnification provision is in addition to, and not in lieu of, any other indemnity agreements contacted in the Contract Documents.

#### **008.3.05. SUBCONTRACTING**

- A. The Contractor may utilize the services of specialty subcontractors on those parts of the work which, under normal contracting practices, are performed by specialty subcontractors.
- B. The Contractor shall not award any work to any subcontractor without prior written approval of the Owner, which approval will not be given until the Contractor submits to the Owner a written statement concerning the proposed award to the subcontractor, which statement shall contain such information as the Owner may require.
- C. The Contractor shall be as fully responsible to the Owner for the acts and omissions of his subcontractors, and of persons either directly or indirectly employed by them, as he is for the acts and omissions of persons directly employed by him.
- D. The Contractor shall cause appropriate provisions to be inserted in all subcontracts relative to the work to bind the subcontractors to the Contractor by the terms of the general conditions and other contract documents insofar as applicable to the work of subcontractors and to give the Contractor the same power

as regards terminating any subcontract that the Owner may exercise over the Contractor under any provision of the contract documents.

- E. Nothing contained in this contract shall create any contractual relation between any subcontractor and the Owner.

#### **008.3.06. USE OF PREMISES AND REMOVAL OF DEBRIS**

The Contractor expressly undertakes at his own expense:

- A. To take every precaution against injuries to persons or damages to property;
- B. To store his apparatus, materials, supplies and equipment in such orderly fashion at the site of the work as will not unduly interfere with the progress of his work or the work of any other Contractors'
- C. To clean up frequently all refuse, rubbish, scrap materials and debris caused by his operations, to the end that at all times the site of the work shall present a neat, orderly and workmanlike appearance.
- D. Before final payment to remove all surplus material, false work, temporary structures, including foundations thereof, plants of any description and debris of every nature resulting from his operations, and to put the site in a neat, orderly condition;
- E. To affect all cutting, fitting, or patching of his work required to make the same to conform to the plans and specifications.

#### **008.3.07. LANDS, RIGHTS-OF-WAY, AND EASEMENTS**

Prior to the start of construction, the Owner shall obtain all lands, rights-of-way and easements necessary for the carrying out and completion of work to be performed under this contract.

#### **008.3.008 CONTRACT REQUIREMENTS**

##### **A. ASSIGNMENT OF CONTRACT**

The contract shall not be assigned in whole or in part without the written consent of the Owner. Involuntary assignment of the contract as caused by the Contractor being adjudged bankrupt, assignment of the contract for the benefit of Contractor's creditors or appointment of a receiver on account of Contractor's insolvency, shall be considered as failure to comply with the provisions of the contract and subject to the termination provisions contained herein.

##### **B. WAIVER OF RIGHTS**

Except as herein provided, no action or want of action on the part of the Contractor, Owner's representative, or construction manager at any time with respect to the exercise of any right or remedies conferred upon them under this contract, shall be deemed to be a waiver on the part of the Contractor and Owner of any of their rights or remedies. No waiver shall be effective except in writing by the party to be charges. No waiver of one right or remedy shall act as a waiver of any other right or remedy or as a subsequent waiver of the same right or remedy.

**C. AMENDMENT OF GENERAL CONDITIONS**

These general conditions may be amended only by mutual consent of the Owner and the Contractor in writing.

**008.3.09 CHOICE OF LAW AND FORUM SELECTION**

This contract shall be interpreted under the laws of the State of Georgia. Any and all disputes arising out of this contract shall be submitted to the Superior Court of Meriwether County and the parties expressly consent to venue and jurisdiction therein.

**008.3.10. MAINTAINING OPERATIONS**

The Contractor shall schedule and execute this work so as to avoid interruption of existing services or operations, public or private. The Contractor will use every precaution to prevent damage to any existing facility, and in the event of damage will, at no expense to the Owner, repair and otherwise make good any damage to facilities resulting from his operations in connection with the contract. The Contractor will take whatever measures necessary to accurately determine the exact location of existing underground facilities prior to commencing construction.

**008.3.11. LIENS**

Neither the final payment nor any part of the retained percentage will become due until the Contractor, if required, shall furnish the Owner a complete release from any liens which might arise out of this contract, or receipts in full in lieu thereof, and if required in either case, an affidavit that insofar as he has knowledge or information, the releases and receipts include all materials for which a lien might be filed. The Contractor may, if any subcontractor refuses to furnish a release or receipt in full, furnish a bond satisfactory to the Owner to indemnify it against any lien. If a lien shall remain unsatisfied after all payments are made, then the Contractor shall refund to the Owner all monies which the latter may be compelled to pay in discharging such lien, including all incidental costs and attorney's fees.

**SECTION 9**  
**ATTACHMENTS**

- 9.1.01      Project Location Map**
- 9.1.02      GDOT Specifications 2403**
- 9.1.03      GDOT Specifications 2404**
- 9.1.04      GDOT Specifications 2530P**
- 9.1.05      GDOT Specifications 2535P**
- 9.1.06      Hydrology Calculations**



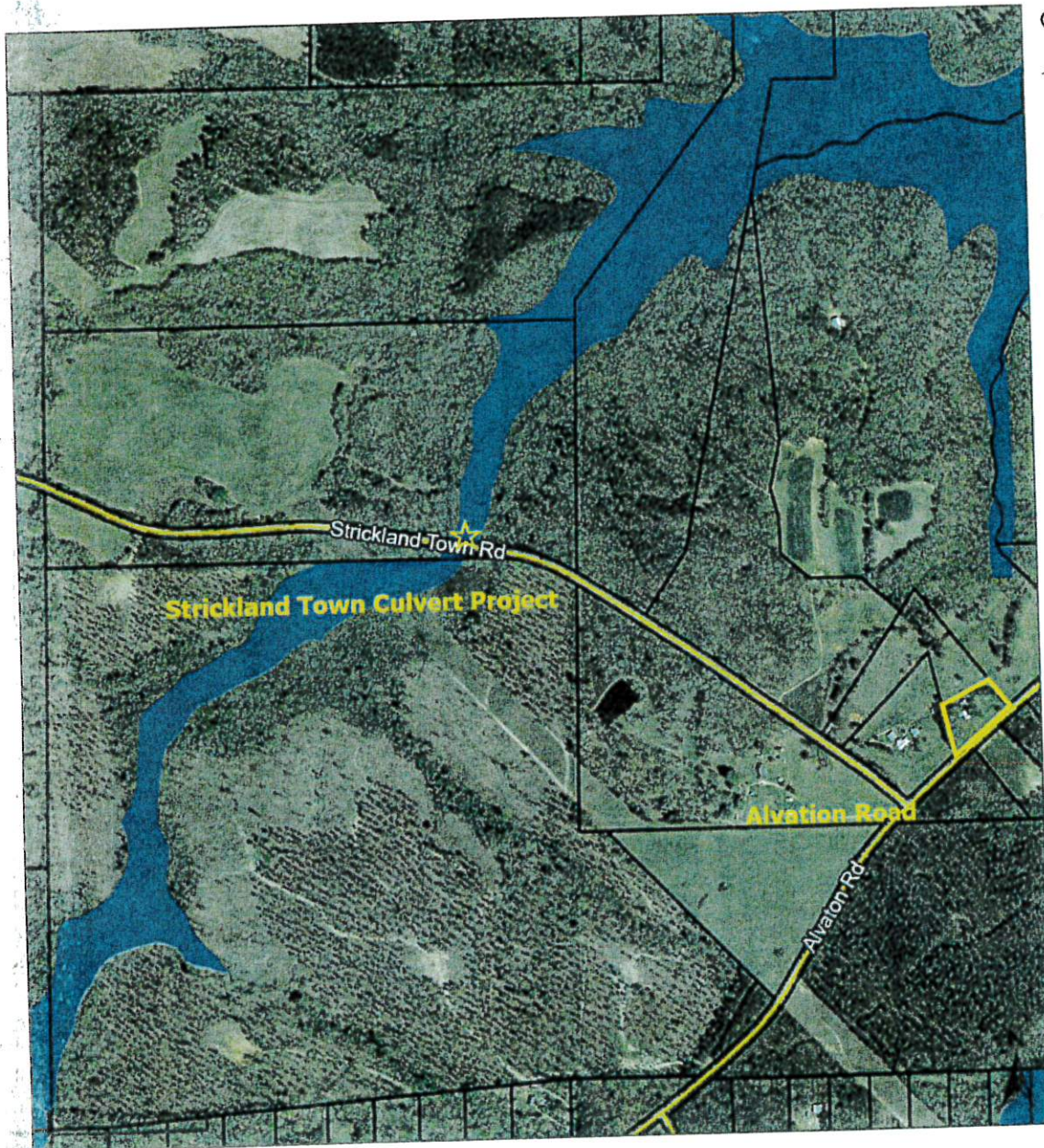





Overview



Legend

-  Parcels
-  Roads
- Flood Map**
  -  A - 100 Year Flood Area - Areas of 1% annual chance flood also known as the base flood. Base Flood Elevations (BFE) have not been determined.
  -  AE -100 Year Flood Area - Areas of 1% annual chance flood also known as the base flood. Determined by detailed methods with Base Flood Elevations (BFE).
  -  AE - Floodway
    - X: 500 Year Flood - Areas of 0.2% annual chance flood

Date created: 5/3/2023  
Last Data Uploaded: 5/3/2023 2:19:02 PM

Developed by  Schneider  
GEOSPATIAL

STATE	PROJECT NUMBER	SHEET NO.	TOTAL SHEETS
GA.			

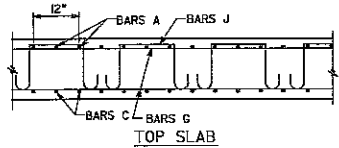

NOTE: SPACING OF BARS A AND C IS 6" OR 12". SEE BARREL REINFORCEMENT QUANTITIES AND DIMENSIONS.

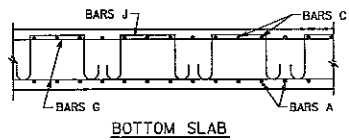

NOTE: LONGITUDINAL WINGWALL AND PARAPET BARS EXTEND INTO BARREL. SEE WINGWALL AND PARAPET STANDARDS.

SECTION A-A

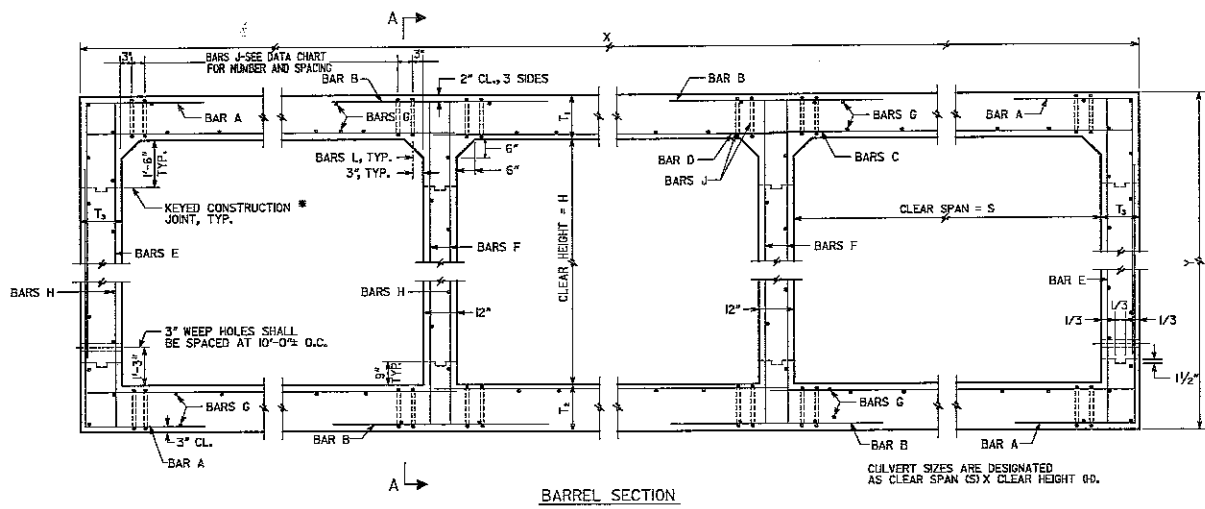

CULVERT SIZES ARE DESIGNATED AS CLEAR SPAN (S) X CLEAR HEIGHT (H).

\* AT CONTRACTORS OPTION, THE LOWER CONSTRUCTION JOINT IN THE BARREL WALL MAY BE SHIFTED TO 6" ABOVE THE TOP OF THE BOTTOM SLAB.

FOR BAR DIMENSIONS SEE BAR REINFORCEMENT DETAILS. NUMBER OF J BARS SHOWN IN DATA CHART IS THE NUMBER PER CORNER IN ANY ONE TRANSVERSE PLANE. THE TOTAL NUMBER OF J BARS REQUIRED DEPENDS UPON THE LENGTH OF THE SECTION.

DESIGN	1	2	3	4	5	6	7	8
MAXIMUM FILL HEIGHT	10'	20'	30'	40'	50'	60'	70'	80'

- MINIMUM HEIGHT FROM TOP OF CULVERT TO BOTTOM OF BASE WITHIN TRAVELWAY SHALL BE 1'-0".
- DESIGN OF THE CULVERT SHALL BE DETERMINED BY THE MAXIMUM HEIGHT OF FILL WITH ONLY A SINGLE DESIGN BEING USED FOR THE ENTIRE INSTALLATION.
- TRANSVERSE CONSTRUCTION JOINTS SHALL BE PLACED NORMAL TO THE CENTERLINE OF THE CULVERT AT THE OUTSIDE SHOULDER BREAK POINTS. THE MAXIMUM POUR LENGTH ALONG THE LENGTH OF THE CULVERT SHALL NOT EXCEED 40'-0" FOR DESIGNS 1 TO 3 AND 30'-0" FOR DESIGNS 4 AND ABOVE.
- LONGITUDINAL BARREL REINFORCEMENT STEEL IN THE TRANSVERSE CONSTRUCTION JOINTS SHALL EXTEND THROUGH JOINTS.
- CONSTRUCTION JOINTS SHALL BE WATERPROOFED ON THE EXTERIOR TOP AND SIDES OF BARREL IN ACCORDANCE WITH SECTION 530 OF GEORGIA STANDARD SPECIFICATIONS. WATERPROOFING SHALL BE APPLIED WHEN CONCRETE IS AT LEAST 7 DAYS OLD. ALL COSTS ASSOCIATED WITH WATERPROOFING SHALL BE INCLUDED IN OTHER ITEMS AND WILL NOT BE MEASURED SEPARATELY FOR PAYMENT.
- MINIMUM LENGTH OF LAP SPICE FOR LONGITUDINAL BARREL REINFORCING STEEL SHALL BE 2'-0".

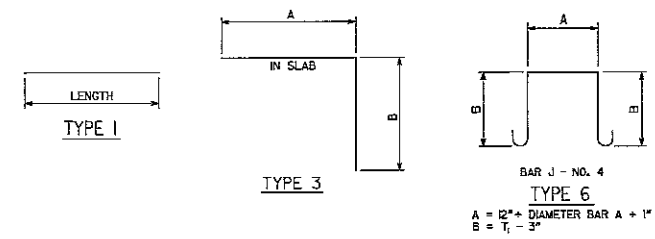

**GENERAL NOTES**

- SPECIFICATIONS: GEORGIA STANDARD, CURRENT EDITION & SUPPLEMENTS THERETO.
- ALL CONCRETE SHALL BE CLASS "AA".
- CHAMFER ALL EXPOSED EDGES 3/4".
- COST OF DRAIN PIPES, WEEP HOLES, COARSE AGGREGATE, AND ANY OTHER INCIDENTAL ITEMS SHALL BE INCLUDED IN THE PRICE BID FOR CONTRACT ITEMS.
- CONSTRUCTION JOINTS IN BARREL WALLS ARE REQUIRED.
- FOR DETAILS OF WINGWALLS AND PARAPETS SEE "REINFORCED CONCRETE WINGWALLS, TOEWALLS AND PARAPETS FOR CONCRETE BOX CULVERTS" SHEETS.

**DESIGN DATA**

SPECIFICATIONS - AASHTO LRFD BRIDGE DESIGN SPECIFICATIONS, 7TH EDITION, 2014. TYPICAL HL-93 LOADING.

DEPARTMENT OF TRANSPORTATION STATE OF GEORGIA			
STANDARD REINFORCED CONCRETE TRIPLE BOX CULVERT			
NO SCALE		SEPTEMBER 2017	
DES. YSK	BY	DATE	NUMBER
DRW. FGS	REVISION		2403
TRM.			SHEET 1 OF 3
CHK. JRS.			

APPROVED: *Marcelo E. Pirelo* CHIEF ENGINEER

SCALE	PROJECT NUMBER	SHEET NO.	TOTAL SHEETS
GA.			

TRIPLE 10'-0" X 5'-0" BOX CULVERT								
BARREL REINFORCEMENT QUANTITIES AND DIMENSIONS								
DESIGN	1	2	3	4	5	6	7	8
BAR A	450 @ 6"	449 @ 6"	534 @ 6"	534 @ 6"	603A @ 6"			
BAR B	486 @ 6"	587 @ 6"	657 @ 6"	656 @ 6"	759 @ 6"			
BAR C	702 @ 12"	553 @ 6"	518 @ 6"	602 @ 6"	618 @ 6"			
BAR D	458 @ 6"	455 @ 6"	455 @ 6"	710 @ 12"	710 @ 12"			
BAR E	431 @ 12"	423 @ 12"	426 @ 12"	426 @ 12"	430 @ 12"			
BAR F	582 @ 12"	423 @ 12"	426 @ 12"	426 @ 12"	480 @ 12"			
BAR G IN 2 SLABS	96 - 401	102 - 401	102 - 401	120 - 401	120 - 401			
BAR H IN 4 WALLS	26 - 402	26 - 402	26 - 402	32 - 402	32 - 402			
BAR J IN EXT. CORNER	0	0	0	0	0			
BAR J IN INT. CORNER	0	0	3-4218 @ 11 1/2"	3-4218 @ 11 1/2"	4-4322 @ 11 1/2"			
T <sub>1</sub>	14"	15"	18"	20"	22"			
T <sub>2</sub>	15"	17"	19"	21"	23"			
T <sub>3</sub>	14"	16"	18"	20"	22"			
X	34'-4"	34'-0"	35'-0"	35'-4"	35'-8"			
Y	7'-5"	7'-9"	8'-1"	8'-5"	8'-9"			
YD CLASS AA CONCRETE/FT	3,903	4,423	4,959	5,487	6,071			
LB BAR REINF STEEL/FT	360.5	326.0	352.8	386.5	408.6			
PARAPET, BARREL END, AND TOEWALL QUANTITIES - 90° SKEW - TOTAL								
YD CLASS AA CONCRETE	14.1	15.5	14.9	15.3	16.3			
LB BAR REINF STEEL	1830	1878	1872	2077	2271			
PARAPET, BARREL END, AND TOEWALL QUANTITIES - 75° SKEW - TOTAL								
YD CLASS AA CONCRETE	15.7	15.1	15.5	15.9	16.5			
LB BAR REINF STEEL	2308	2261	2303	2370	2568			
PARAPET, BARREL END, AND TOEWALL QUANTITIES - 60° SKEW - TOTAL								
YD CLASS AA CONCRETE	16.4	16.8	17.3	17.7	18.2			
LB BAR REINF STEEL	2453	2508	2507	2720	2785			
PARAPET, BARREL END, AND TOEWALL QUANTITIES - 45° SKEW - TOTAL								
YD CLASS AA CONCRETE	20.1	20.7	21.2	21.8	22.4			
LB BAR REINF STEEL	2750	2847	2849	3057	3069			

TRIPLE 10'-0" X 6'-0" BOX CULVERT								
BARREL REINFORCEMENT QUANTITIES AND DIMENSIONS								
DESIGN	1	2	3	4	5	6	7	8
BAR A	498A @ 6"	490A @ 6"	704A @ 12"	590A @ 6"	560A @ 6"			
BAR B	426 @ 6"	336 @ 6"	654 @ 6"	710 @ 6"	738 @ 6"			
BAR C	702 @ 12"	523 @ 6"	611 @ 6"	612 @ 6"	714 @ 6"			
BAR D	495 @ 6"	455 @ 6"	455 @ 6"	711 @ 12"	711 @ 12"			
BAR E	426 @ 12"	430 @ 12"	433 @ 12"	437 @ 12"	440 @ 12"			
BAR F	582 @ 12"	430 @ 12"	433 @ 12"	437 @ 12"	440 @ 12"			
BAR G IN 2 SLABS	96 - 401	102 - 401	102 - 401	120 - 401	120 - 401			
BAR H IN 4 WALLS	34 - 402	34 - 402	34 - 402	46 - 402	46 - 402			
BAR J IN EXT. CORNER	0	0	0	0	0			
BAR J IN INT. CORNER	0	0	3-4218 @ 11 1/2"	3-4218 @ 11 1/2"	3-4218 @ 11 1/2"			
T <sub>1</sub>	14"	15"	18"	20"	22"			
T <sub>2</sub>	15"	17"	19"	21"	23"			
T <sub>3</sub>	14"	16"	18"	20"	22"			
X	34'-4"	34'-0"	35'-0"	35'-4"	35'-8"			
Y	8'-5"	8'-9"	9'-1"	9'-5"	9'-9"			
YD CLASS AA CONCRETE/FT	4,064	4,596	5,136	5,584	6,241			
LB BAR REINF STEEL/FT	375.9	480.4	568.9	674.4	733.1			
PARAPET, BARREL END, AND TOEWALL QUANTITIES - 90° SKEW - TOTAL								
YD CLASS AA CONCRETE	14.5	15.9	15.5	15.7	16.5			
LB BAR REINF STEEL	1882	1830	1824	2026	2296			
PARAPET, BARREL END, AND TOEWALL QUANTITIES - 75° SKEW - TOTAL								
YD CLASS AA CONCRETE	15.0	15.4	15.9	16.3	16.8			
LB BAR REINF STEEL	2362	2405	2405	2553	2681			
PARAPET, BARREL END, AND TOEWALL QUANTITIES - 60° SKEW - TOTAL								
YD CLASS AA CONCRETE	15.7	17.2	17.7	18.2	18.7			
LB BAR REINF STEEL	2508	2563	2562	2805	2828			
PARAPET, BARREL END, AND TOEWALL QUANTITIES - 45° SKEW - TOTAL								
YD CLASS AA CONCRETE	20.5	21.1	21.7	22.4	23.0			
LB BAR REINF STEEL	2871	2905	2907	3167	3210			

TRIPLE 10'-0" X 7'-0" BOX CULVERT								
BARREL REINFORCEMENT QUANTITIES AND DIMENSIONS								
DESIGN	1	2	3	4	5	6	7	8
BAR A	516A @ 12"	488A @ 6"	TOTAL @ 12"	568A @ 6"	571A @ 6"			
BAR B	748 @ 12"	699 @ 6"	693 @ 6"	738 @ 6"	737 @ 6"			
BAR C	702 @ 12"	553 @ 6"	611 @ 6"	612 @ 6"	714 @ 6"			
BAR D	498 @ 6"	453 @ 6"	453 @ 6"	711 @ 12"	711 @ 12"			
BAR E	437 @ 12"	440 @ 12"	442 @ 12"	444 @ 12"	447 @ 12"			
BAR F	437 @ 12"	440 @ 12"	442 @ 12"	444 @ 12"	447 @ 12"			
BAR G IN 2 SLABS	96 - 401	102 - 401	102 - 401	120 - 401	120 - 401			
BAR H IN 4 WALLS	40 - 402	40 - 402	40 - 402	46 - 402	46 - 402			
BAR J IN EXT. CORNER	0	0	0	0	0			
BAR J IN INT. CORNER	0	0	3-4218 @ 11 1/2"	3-4218 @ 11 1/2"	3-4218 @ 11 1/2"			
T <sub>1</sub>	14"	16"	18"	20"	22"			
T <sub>2</sub>	15"	17"	19"	21"	23"			
T <sub>3</sub>	14"	16"	18"	20"	22"			
X	34'-4"	34'-8"	35'-0"	35'-4"	35'-8"			
Y	9'-5"	9'-9"	10'-1"	10'-5"	10'-9"			
YD CLASS AA CONCRETE/FT	4,224	4,769	5,320	5,882	6,465			
LB BAR REINF STEEL/FT	393.1	423.5	505.6	683.1	744.8			
PARAPET, BARREL END, AND TOEWALL QUANTITIES - 90° SKEW - TOTAL								
YD CLASS AA CONCRETE	14.9	15.3	15.8	16.2	16.7			
LB BAR REINF STEEL	1912	1911	1955	2160	2333			
PARAPET, BARREL END, AND TOEWALL QUANTITIES - 75° SKEW - TOTAL								
YD CLASS AA CONCRETE	15.4	16.3	16.4	16.8	17.3			
LB BAR REINF STEEL	2394	2447	2445	2656	2824			
PARAPET, BARREL END, AND TOEWALL QUANTITIES - 60° SKEW - TOTAL								
YD CLASS AA CONCRETE	17.2	17.7	18.3	18.8	19.3			
LB BAR REINF STEEL	2541	2596	2596	2809	2808			
PARAPET, BARREL END, AND TOEWALL QUANTITIES - 45° SKEW - TOTAL								
YD CLASS AA CONCRETE	21.2	21.8	22.4	23.1	23.7			
LB BAR REINF STEEL	2882	2940	2942	3161	3263			

TRIPLE 10'-0" X 8'-0" BOX CULVERT								
BARREL REINFORCEMENT QUANTITIES AND DIMENSIONS								
DESIGN	1	2	3	4	5	6	7	8
BAR A	564A @ 12"	473A @ 6"	709A @ 12"	574A @ 6"	576A @ 6"			
BAR B	738 @ 12"	694 @ 6"	693 @ 6"	737 @ 6"	736 @ 6"			
BAR C	702 @ 12"	553 @ 6"	611 @ 6"	612 @ 6"	714 @ 6"			
BAR D	498 @ 6"	453 @ 6"	453 @ 6"	711 @ 12"	711 @ 12"			
BAR E	444 @ 12"	447 @ 12"	449 @ 12"	451 @ 12"	453 @ 12"			
BAR F	444 @ 12"	447 @ 12"	449 @ 12"	451 @ 12"	453 @ 12"			
BAR G IN 2 SLABS	96 - 401	102 - 401	102 - 401	120 - 401	120 - 401			
BAR H IN 4 WALLS	42 - 402	42 - 402	42 - 402	50 - 402	50 - 402			
BAR J IN EXT. CORNER	0	0	0	0	0			
BAR J IN INT. CORNER	0	0	3-4218 @ 11 1/2"	3-4218 @ 11 1/2"	3-4218 @ 11 1/2"			
T <sub>1</sub>	14"	16"	18"	20"	22"			
T <sub>2</sub>	15"	17"	19"	21"	23"			
T <sub>3</sub>	14"	16"	18"	20"	22"			
X	34'-4"	34'-8"	35'-0"	35'-4"	35'-8"			
Y	10'-5"	10'-9"	11'-1"	11'-5"	11'-9"			
YD CLASS AA CONCRETE/FT	4,385	4,941	5,506	6,078	6,660			
LB BAR REINF STEEL/FT	407.6	493.7	594.6	703.5	778.2			
PARAPET, BARREL END, AND TOEWALL QUANTITIES - 90° SKEW - TOTAL								
YD CLASS AA CONCRETE	15.4	16.9	16.4	16.8	17.3			
LB BAR REINF STEEL	1944	1934	1934	2246	2296			
PARAPET, BARREL END, AND TOEWALL QUANTITIES - 75° SKEW - TOTAL								
YD CLASS AA CONCRETE	16.0	16.8	17.0	17.8	18.0			
LB BAR REINF STEEL	2424	2477	2475	2745	2744			
PARAPET, BARREL END, AND TOEWALL QUANTITIES - 60° SKEW - TOTAL								
YD CLASS AA CONCRETE	17.8	18.4	18.9	19.5	20.1			
LB BAR REINF STEEL	2571	2626	2626	2829	2809			
PARAPET, BARREL END, AND TOEWALL QUANTITIES - 45° SKEW - TOTAL								
YD CLASS AA CONCRETE	21.8	22.6	23.2	23.9	24.6			
LB BAR REINF STEEL	2963	2971	2974	3297	3260			

DEPARTMENT OF TRANSPORTATION  
STATE OF GEORGIA

STANDARD  
REINFORCED CONCRETE  
TRIPLE BOX CULVERT  
10'X5', 10'X6', 10'X7' AND 10'X8'

NO SCALE SEPTEMBER 2017

DES. BY	DATE	NUMBER
CHK. BY	DATE	2403
APPROVED: <i>[Signature]</i> STATE DESIGN POLICE ENGINEER		SHEET 2-14 OF 3





CULVERT SIZE CLEAR SPAN (FT) CLEAR HEIGHT (FT)	DESIGN I-A 2 FT. MINIMUM COVER						DESIGN I-B 3 FT. MINIMUM COVER						CULVERT SIZE CLEAR SPAN (FT) CLEAR HEIGHT (FT)
	MINIMUM AREA OF CIRCUMFERENTIAL REINFORCING STEEL (SQ. IN. PER LIN. FT.)						MINIMUM AREA OF CIRCUMFERENTIAL REINFORCING STEEL (SQ. IN. PER LIN. FT.)						
	AS1	AS2	AS3	AS4	AS5	AS6	AS1	AS2	AS3	AS4	AS5	AS6	
4'	3	6	0.21	0.27	0.12	16	0.13	0.18	0.12	10	6	3	
	4	6	0.18	0.30	0.12	16	0.12	0.19	0.12	10	6	4	
	6	7	0.27	0.37	0.17	16	0.20	0.27	0.17	10	7	6	
5'	3	6	0.28	0.29	0.14	16	0.17	0.21	0.14	10	6	3	
	4	6	0.24	0.33	0.14	16	0.16	0.23	0.14	10	6	4	
	6	7	0.25	0.39	0.17	16	0.18	0.29	0.17	10	7	6	
6'	3	7	0.32	0.33	0.17	16	0.23	0.23	0.17	10	7	3	
	4	7	0.27	0.37	0.17	16	0.20	0.27	0.17	10	7	4	
	6	7	0.23	0.41	0.17	16	0.16	0.30	0.17	10	7	6	
7'	4	8	0.35	0.41	0.19	16	0.25	0.27	0.19	10	8	4	
	6	8	0.31	0.44	0.19	16	0.23	0.29	0.19	10	8	6	
	8	8	0.29	0.47	0.19	14	0.21	0.34	0.19	10	8	8	
8'	7	8	0.26	0.44	0.19	14	0.19	0.36	0.19	10	8	7	
	8	8	0.45	0.40	0.19	10	0.35	0.30	0.19	8	8	8	
	9	8	0.39	0.43	0.19	10	0.30	0.33	0.19	8	8	9	
9'	8	8	0.33	0.47	0.19	10	0.27	0.35	0.19	8	8	6	
	7	8	0.33	0.50	0.19	10	0.25	0.34	0.19	8	8	7	
	8	8	0.31	0.53	0.19	10	0.24	0.43	0.19	8	8	8	
10'	4	9	0.47	0.53	0.22	10	0.38	0.38	0.22	8	9	4	
	5	9	0.43	0.45	0.22	10	0.35	0.39	0.22	8	9	5	
	6	9	0.40	0.48	0.22	10	0.32	0.42	0.22	8	9	6	
10'	7	9	0.37	0.52	0.22	10	0.30	0.45	0.22	8	9	7	
	8	9	0.33	0.54	0.22	10	0.28	0.47	0.22	8	9	8	
	9	9	0.33	0.57	0.22	10	0.27	0.49	0.22	8	9	9	
10'	10	10	0.35	0.61	0.24	10	0.30	0.53	0.24	8	10	10	
	4	10	0.50	0.46	0.24	10	0.44	0.42	0.24	8	10	4	
	5	10	0.47	0.46	0.24	10	0.41	0.45	0.24	8	10	5	
10'	6	10	0.44	0.50	0.24	10	0.38	0.45	0.24	8	10	6	
	7	10	0.41	0.53	0.24	10	0.35	0.48	0.24	8	10	7	
	8	10	0.38	0.56	0.24	10	0.33	0.51	0.24	8	10	8	
10'	9	10	0.36	0.60	0.24	10	0.32	0.53	0.24	8	10	9	
	10	10	0.35	0.61	0.24	10	0.30	0.55	0.24	8	10	10	

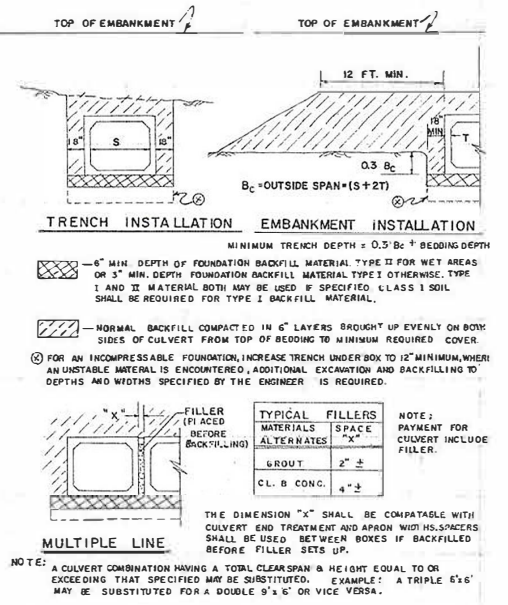
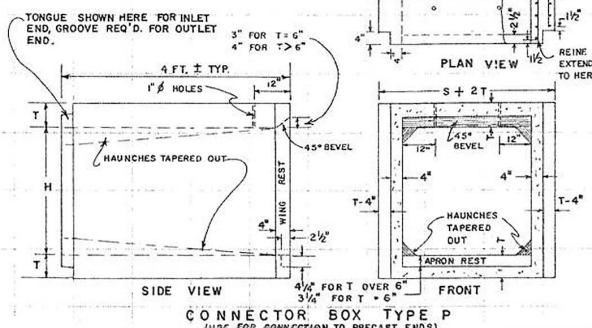
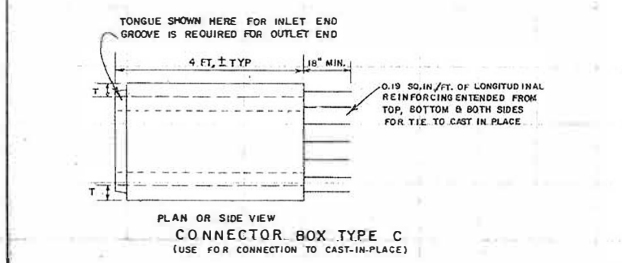
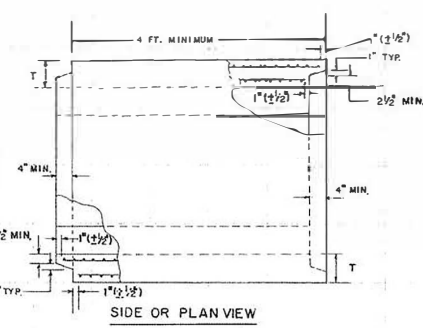
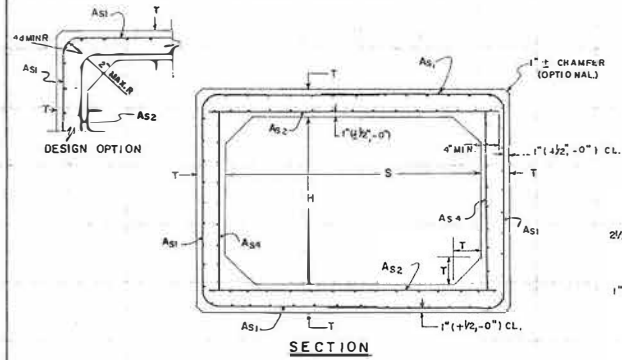

**TRENCH INSTALLATION**      **EMBANKMENT INSTALLATION**

MINIMUM TRENCH DEPTH = 0.3 Bc + BEDDING DEPTH

6" MIN. DEPTH OF FOUNDATION BACKFILL MATERIAL TYPE T FOR WET AREAS OR 3" MIN. DEPTH FOUNDATION BACKFILL MATERIAL TYPE I OTHERWISE TYPE I AND II MATERIAL BOTH MAY BE USED IF SPECIFIED CLASS I SOIL SHALL BE REQUIRED FOR TYPE I BACKFILL MATERIAL.

NORMAL BACKFILL COMPACTED IN 6" LAYERS BROUGHT UP EVENLY ON BOTH SIDES OF CULVERT FROM TOP OF BEDDING TO MINIMUM REQUIRED COVER

FOR AN INCOMPRESSIBLE FOUNDATION, INCREASE TRENCH UNDER BOX TO 12" MINIMUM WHEN AN UNSTABLE MATERIAL IS ENCOUNTERED. ADDITIONAL EXCAVATION AND BACKFILLING TO DEPTHS AND WIDTHS SPECIFIED BY THE ENGINEER IS REQUIRED.

**TYPICAL FILLERS**

MATERIALS	SPACE
FILLER (FI ACED)	"X"
RETICULAR BACKFILLING	"X"
GRAVEL	2" ±
CL. B CONC.	4" ±

NOTE: PAYMENT FOR CULVERT INCLUDE FILLER.

THE DIMENSION "X" SHALL BE COMPATIBLE WITH CULVERT END TREATMENT AND APRON WIDTH SPACERS SHALL BE USED BETWEEN BOXES IF BACKFILLED BEFORE FILLER SET UP.

**NOTE:** A CULVERT COMBINATION HAVING A TOTAL CLEAR SPAN & HEIGHT EQUAL TO OR EXCEEDING THAT SPECIFIED MAY BE SUBSTITUTED. EXAMPLE: A TRIPLE 6'S" MAY BE SUBSTITUTED FOR A DOUBLE 9'S" OR VICE VERSA.

**DEPARTMENT OF TRANSPORTATION**  
STATE OF GEORGIA

**STANDARD**  
**PRECAST BOX CULVERT BARRELS**  
4' x 3' THRU 10' x 10'  
SINGLE & MULTIPLE LINES

NO SCALE      MARCH, 1985

DES. R.M.U.      SUBMITTED BY: *John A. ...*      NUMBER  
 DRW. R.M.U.      STATE ROAD & AIRPORT DESIGN ENGR  
 TRA. G.M.E.      (APPROVED) *John A. ...*      2530 P  
 CHK. R.M.C.      STATE HIGHWAY ENGINEER

DEPARTMENT OF TRANSPORTATION	STATE OF GEORGIA
STANDARD	WINGWALLS, PARAPETS, TOWALLS & APRONS
PRECAST BOX CULVERT ENDS	
MARCH, 1955	NUMBER 2035P
QUANTITY	STATE HIGHWAY ENGINEER
DATE	APPROVED
BY	
CHK. R.R.C.	

NOTE: EACH PARAPET SHALL BE BUILT TO BOX WITH TWO-3/4" GALV. BOLTS WITH 2 GALV. WASHERS WITH EACH

TABLE 1 - PARAPET DIMENSIONS

GA.	PROJECT NUMBER	NO.	HEIGHT
10'		10'	1'-0"
9'		9'	1'-0"
8'		8'	1'-0"
7'		7'	1'-0"
6'		6'	1'-0"
5'		5'	1'-0"
4'		4'	1'-0"
3'		3'	1'-0"
2'		2'	1'-0"
1'		1'	1'-0"

TABLE 2 - WINGWALL DIMENSIONS, ANCHOR SPACINGS, WINGWALL & APRON REINFORCING

WINGWALL HEIGHT (ft.)	WINGWALL WIDTH (ft.)	ANCHOR SPACING (ft.)	WINGWALL REINFORCING	APRON REINFORCING
10'	10'	12"	4#4 @ 12" O.C. MAX.	4#4 @ 12" O.C. MAX.
9'	9'	12"	4#4 @ 12" O.C. MAX.	4#4 @ 12" O.C. MAX.
8'	8'	12"	4#4 @ 12" O.C. MAX.	4#4 @ 12" O.C. MAX.
7'	7'	12"	4#4 @ 12" O.C. MAX.	4#4 @ 12" O.C. MAX.
6'	6'	12"	4#4 @ 12" O.C. MAX.	4#4 @ 12" O.C. MAX.
5'	5'	12"	4#4 @ 12" O.C. MAX.	4#4 @ 12" O.C. MAX.
4'	4'	12"	4#4 @ 12" O.C. MAX.	4#4 @ 12" O.C. MAX.
3'	3'	12"	4#4 @ 12" O.C. MAX.	4#4 @ 12" O.C. MAX.
2'	2'	12"	4#4 @ 12" O.C. MAX.	4#4 @ 12" O.C. MAX.
1'	1'	12"	4#4 @ 12" O.C. MAX.	4#4 @ 12" O.C. MAX.

TABLE 3 - TOWALL DIMENSIONS

WINGWALL HEIGHT (ft.)	TOWALL WIDTH (ft.)	ANCHOR SPACING (ft.)	TOWALL REINFORCING
10'	10'	12"	4#4 @ 12" O.C. MAX.
9'	9'	12"	4#4 @ 12" O.C. MAX.
8'	8'	12"	4#4 @ 12" O.C. MAX.
7'	7'	12"	4#4 @ 12" O.C. MAX.
6'	6'	12"	4#4 @ 12" O.C. MAX.
5'	5'	12"	4#4 @ 12" O.C. MAX.
4'	4'	12"	4#4 @ 12" O.C. MAX.
3'	3'	12"	4#4 @ 12" O.C. MAX.
2'	2'	12"	4#4 @ 12" O.C. MAX.
1'	1'	12"	4#4 @ 12" O.C. MAX.

GENERAL NOTES:

1. SPECIFICATION: AS STANDARD, CURRENT EDITION & SUPPLEMENTS THERE TO.
2. MATERIALS FOR PRECAST BRACKETS, PRECAST WINGWALLS AND PRECAST APRONS SHALL BE 3000 PSI. CONCRETE (SEC. 500) AND WEIGHT 150 LB. PER CU. YD. REINFORCING SHALL BE AS SPECIFIED IN SECTION 500.
3. ALL PRECAST WINGWALLS (WITH LIGHT ORIENT) REQUIRE "B" THICK PARAPET CONNECTIONS AND SHALL BE REINFORCED WITH 4#4 BARS AT 12" O.C. MAX. PARAPET CONNECTIONS SHALL BE REINFORCED WITH 4#4 BARS AT 12" O.C. MAX. PARAPET CONNECTIONS SHALL BE REINFORCED WITH 4#4 BARS AT 12" O.C. MAX. PARAPET CONNECTIONS SHALL BE REINFORCED WITH 4#4 BARS AT 12" O.C. MAX.
4. OUTLET BARRIERS SHALL BE 2" x 4" CONCRETE WITH REINFORCING WITH NO. 4 BARS AT 12" O.C. MAX. PARAPET CONNECTIONS SHALL BE REINFORCED WITH 4#4 BARS AT 12" O.C. MAX. PARAPET CONNECTIONS SHALL BE REINFORCED WITH 4#4 BARS AT 12" O.C. MAX.
5. SET STANDARD FOR DETAILS OF PRECAST BOX CULVERTS AND CONNECTIONS SHALL BE AS SPECIFIED IN SECTION 500.
6. LIFTING HOLES AND HANDLING DEVICES SHALL BE ACCORDING TO C.A.S.T. CONNECTION BOXES TYPE P & TYPE C.
7. PRECAST BOX CULVERTS SHALL BE MANUFACTURED IN ACCORDANCE WITH THE SPECIFICATIONS AND HANDLING DEVICES SHALL BE ACCORDING TO C.A.S.T. CONNECTION BOXES TYPE P & TYPE C.
8. SET STANDARD FOR DETAILS OF PRECAST BOX CULVERTS AND CONNECTIONS SHALL BE AS SPECIFIED IN SECTION 500.
9. PRECAST BOX CULVERTS SHALL BE MANUFACTURED IN ACCORDANCE WITH THE SPECIFICATIONS AND HANDLING DEVICES SHALL BE ACCORDING TO C.A.S.T. CONNECTION BOXES TYPE P & TYPE C.
10. PRECAST BOX CULVERTS SHALL BE MANUFACTURED IN ACCORDANCE WITH THE SPECIFICATIONS AND HANDLING DEVICES SHALL BE ACCORDING TO C.A.S.T. CONNECTION BOXES TYPE P & TYPE C.

TABLE 4 - PARAPET DIMENSIONS

GA.	PROJECT NUMBER	NO.	HEIGHT
10'		10'	1'-0"
9'		9'	1'-0"
8'		8'	1'-0"
7'		7'	1'-0"
6'		6'	1'-0"
5'		5'	1'-0"
4'		4'	1'-0"
3'		3'	1'-0"
2'		2'	1'-0"
1'		1'	1'-0"

TABLE 5 - WINGWALL DIMENSIONS, ANCHOR SPACINGS, WINGWALL & APRON REINFORCING

WINGWALL HEIGHT (ft.)	WINGWALL WIDTH (ft.)	ANCHOR SPACING (ft.)	WINGWALL REINFORCING	APRON REINFORCING
10'	10'	12"	4#4 @ 12" O.C. MAX.	4#4 @ 12" O.C. MAX.
9'	9'	12"	4#4 @ 12" O.C. MAX.	4#4 @ 12" O.C. MAX.
8'	8'	12"	4#4 @ 12" O.C. MAX.	4#4 @ 12" O.C. MAX.
7'	7'	12"	4#4 @ 12" O.C. MAX.	4#4 @ 12" O.C. MAX.
6'	6'	12"	4#4 @ 12" O.C. MAX.	4#4 @ 12" O.C. MAX.
5'	5'	12"	4#4 @ 12" O.C. MAX.	4#4 @ 12" O.C. MAX.
4'	4'	12"	4#4 @ 12" O.C. MAX.	4#4 @ 12" O.C. MAX.
3'	3'	12"	4#4 @ 12" O.C. MAX.	4#4 @ 12" O.C. MAX.
2'	2'	12"	4#4 @ 12" O.C. MAX.	4#4 @ 12" O.C. MAX.
1'	1'	12"	4#4 @ 12" O.C. MAX.	4#4 @ 12" O.C. MAX.

TABLE 6 - TOWALL DIMENSIONS

WINGWALL HEIGHT (ft.)	TOWALL WIDTH (ft.)	ANCHOR SPACING (ft.)	TOWALL REINFORCING
10'	10'	12"	4#4 @ 12" O.C. MAX.
9'	9'	12"	4#4 @ 12" O.C. MAX.
8'	8'	12"	4#4 @ 12" O.C. MAX.
7'	7'	12"	4#4 @ 12" O.C. MAX.
6'	6'	12"	4#4 @ 12" O.C. MAX.
5'	5'	12"	4#4 @ 12" O.C. MAX.
4'	4'	12"	4#4 @ 12" O.C. MAX.
3'	3'	12"	4#4 @ 12" O.C. MAX.
2'	2'	12"	4#4 @ 12" O.C. MAX.
1'	1'	12"	4#4 @ 12" O.C. MAX.

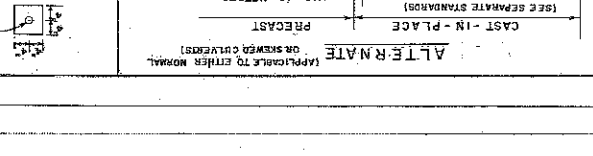
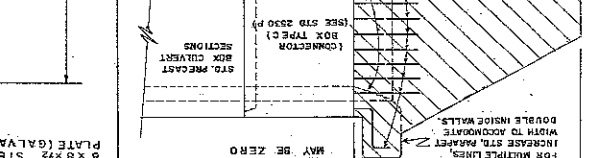
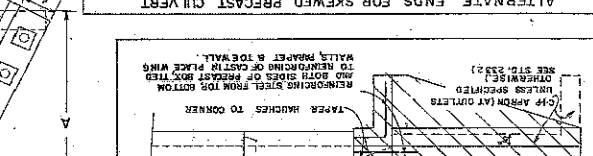
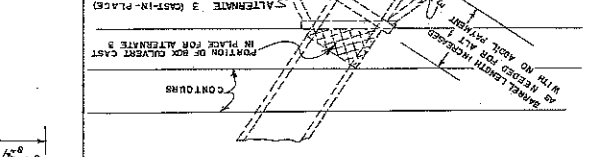
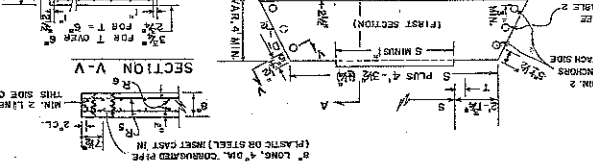
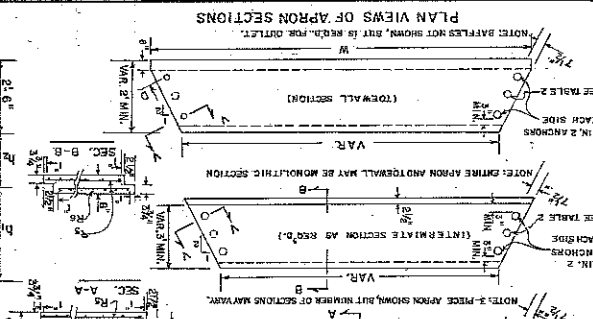
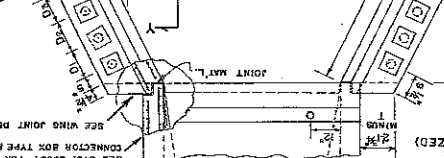
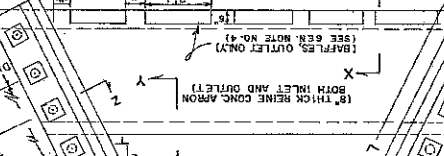
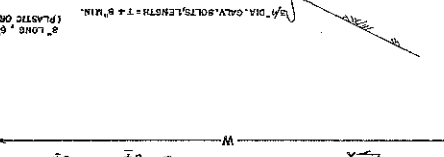
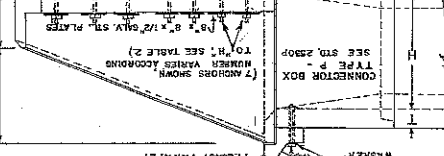
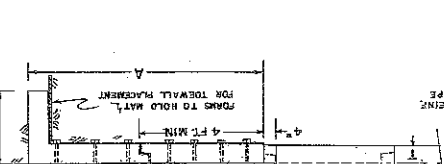
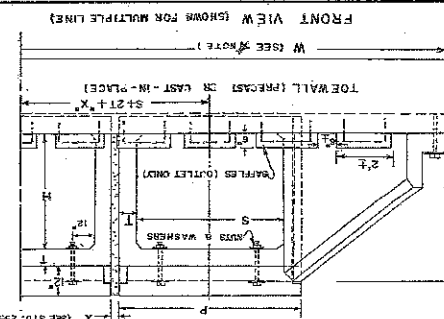
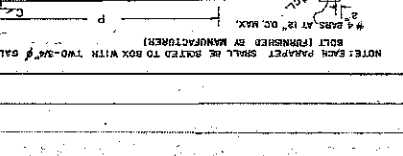
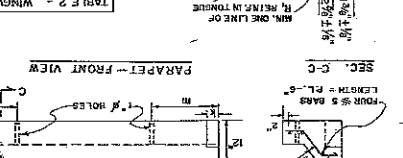
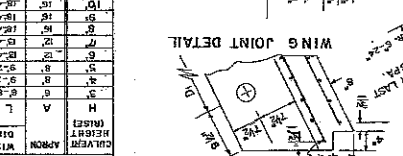
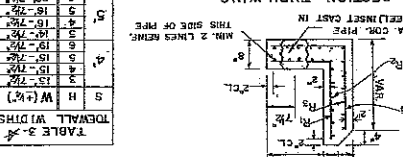
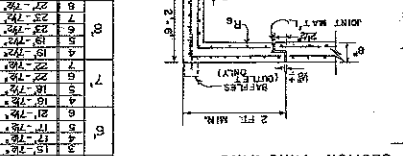
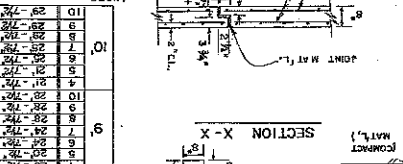
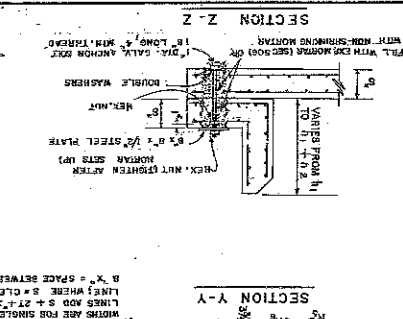

STRICKLAND TOWN RD.

100-YR FLOW = 2070 cfs

TRY TRIPLE 10' x 8' w/1.6' EMBED.

$2070 \div 30 = 69$  (Q/B)

$H = 8' - 1.6' \text{ EMBED} = 6.4$  (H)

CHART 8

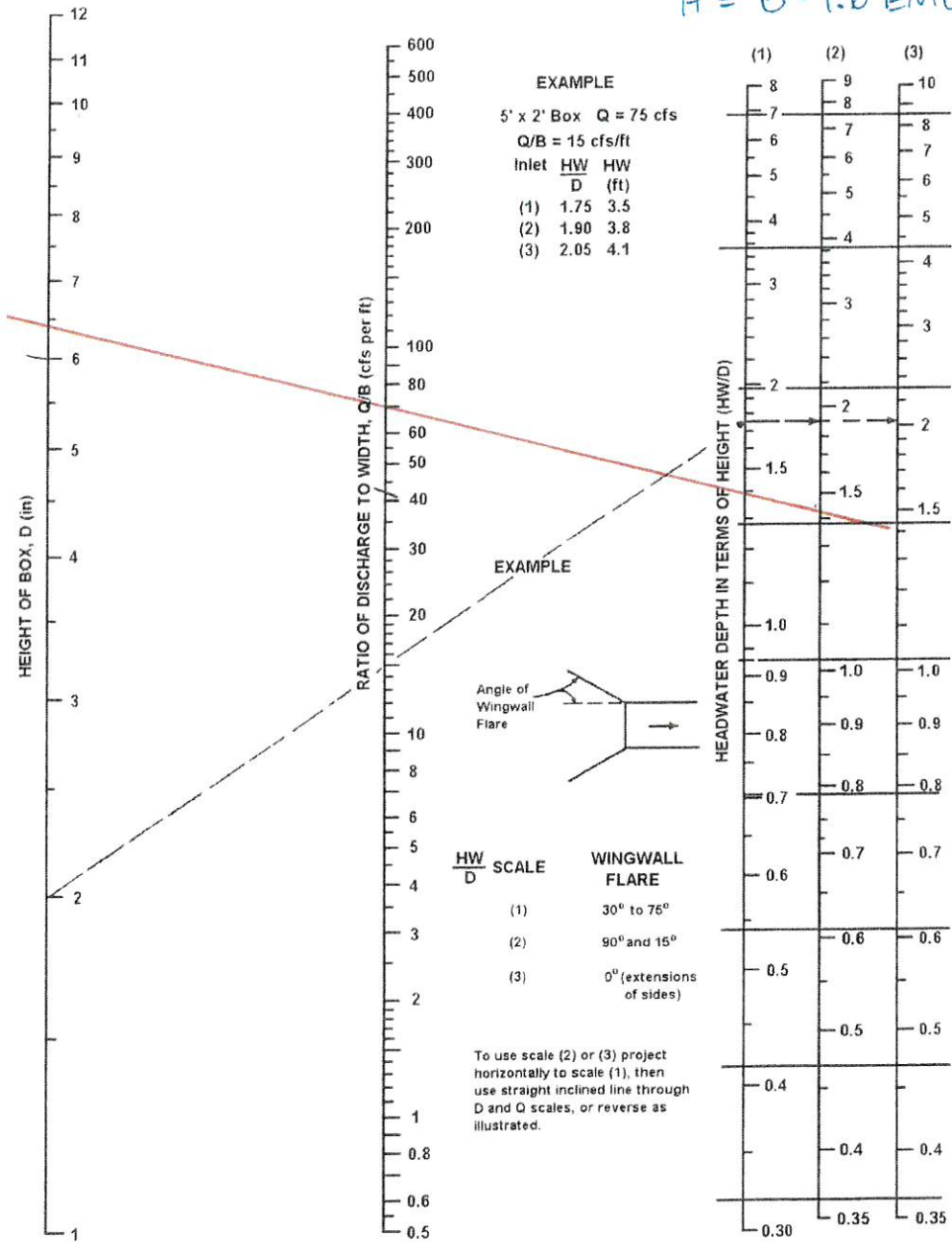

$H/D = 1.4$   
 $HW = (1.4)(6.4)$   
 $= 8.96'$

BUREAU OF PUBLIC ROADS JAN. 1963

HEADWATER DEPTH FOR BOX CULVERTS WITH INLET CONTROL

USE A TRIPLE 10' x 8' BOX EMBEDDED 1.6'