



**OMNIA**<sup>®</sup>  
P A R T N E R S

Project Manual For: **Kendall County Illinois**  
**Kendall County Courthouse**  
**2022- Roofing Project**  
**804 W. Johns St.**  
**Yorkville, IL 60560**

**Omnia Project #:**

Due Date: February 22nd, 2022

**Project Owner :Kendall County  
Facility Management**

**804 W. John St. Suite 316  
Yorkville, IL 60560**



---

## Table of Contents

<b>1 Instruction to Proposers .....</b>	<b>3-4</b>
<b>2 Proposal Forms.....</b>	<b>5-10</b>
<b>3 Prevailing Wage Requirements .....</b>	<b>11</b>
<b>4. Supplemental Conditions (Sample Contract).....</b>	<b>12-25</b>
<b>(Kendall County Requirements).....</b>	<b>26-35</b>
<b>5. EPDM Specification.....</b>	<b>36-43</b>
<b>6. Scope of Work, Details, &amp; Drawings .....</b>	<b>44-47</b>
<b>7. (C.) Contractors Duties.....</b>	<b>48</b>
<b>8. Nuclear Scan Results.....</b>	<b>49-54</b>



# 1 Instruction to Proposers

In accordance with the Invitation to bid labor and materials required to complete the project to Garland/DBS Utilizing the Omnia Purchasing cooperative on behalf of Kendall County, the Proposal form must be submitted in accordance with the following:

## **PROPOSAL DUE DATE: 2-22-2022**

1. Proposals can be submit in one of the following two formats using the Proposal forms as provided herein:
  - a. E-mail proposals to: [DBSbids@garlandind.com](mailto:DBSbids@garlandind.com)
  - b. Fax proposals to: (216) 883-2055
2. If you have any questions regarding the Proposal documents, please call Shawn Browning at #331-216-9115
3. Coordination with the Owner, as specified hereinafter, shall be made exclusively through the General Contractor's Representative: Shawn Browning at #331-216-9115.
4. Proposal Bonds **are not** required for this project. Performance and Payment Bonds will **not be** required if awarded the project. Performance and payment bonds will be provided by Garland/DBS, Inc., herein referred to as "General Contractor" for the project.
5. Time is of the essence prior to contract signing, the number of consecutive working days necessary for the completion of the project shall be established by both parties. The Contractor agrees that failure to complete the scope of work within that stipulated period shall result in the assessment liquidated damages in the amount of \$300 per day past a date to be agreed upon during the pre-construction conference.
6. It is the General Contractor's intention to remit payment of approved invoice amounts within forty-five (45) days of General Contractor's acceptance. Deductions may be made for unapproved amounts invoiced and/or any penalties or damages incurred by the Owner or General Contractor.
7. The final invoice for retention will be paid upon the General Contractor's receipt of final payment by the Owner.
8. All Invoices must be submitted to General Contractor on AIA G702/G703 invoice forms or approved equal.
9. The contractor shall be prepared to submit a Certificate of Insurance with the Owner and General Contractor identified as the additional insured in accordance with the requirements as outlined in the Supplementary Conditions.
10. The Contractor shall be responsible for any building permits required by the City of Yorkville and must comply with all local, State, and Federal requirements.



11. Once the project is awarded the start date will be no later than 9/6/2022 and the contractor must continue to work, full-time and with a sufficient workforce able to faithfully prosecute the Work until final completion is issued by the General Contractor. Roofing must be performed in logical sequence and in accordance with the specification documents as provided herein, deviations will only be allowed under direction of the General Contractor or Owner.
12. **One Proposal sheet shall be completed in full for all buildings in scope.** Unit costs must be provided for additional / optional repair items to be completed on various buildings. Any expected latent or concealed site conditions should be identified upfront with unit pricing.
13. Proposers are reminded that the General Contractor is purchasing the Garland roof system materials for this project. Proposers should adjust profit and overhead accordingly as they are not incurring the expense of the materials, but will still need to handle the materials and load the roof once the materials arrive to the site.
14. Proposers are reminded that the freight for the General Contractor supplied materials will be paid for by the General Contractor and will not be an expense to the Proposer.
15. Proposers are reminded that sales or use tax on the General Contractor supplied materials will be paid for by the General Contractor and will not be an expense to the Proposer.
16. Proposers are responsible for all materials not supplied by the General Contractor, as well as, the costs, freight, and sales or use taxes, if applicable.



## 2 Proposal Forms

Proposer must completely fill-out the following Proposal forms and submit them via the following methods:

1. E-mail Proposals to: [DBSbids@garlandind.com](mailto:DBSbids@garlandind.com)
2. Fax Proposals to: (216) 883-2055

Proposers should use best efforts to identify potential latent or concealed site conditions and provide unit costs for them in the appropriate section of the Proposal documents as to establish pricing for what may be unforeseen site conditions upfront.

### **PLEASE DOUBLE CHECK YOUR PRICING TO BE AS COMPETITIVE AS POSSIBLE:**

1.  The General Contractor is purchasing the Garland roof system materials for this project.
  - a. Adjust profit and overhead accordingly as you are not incurring the expense of the materials
  - b. Account for the handling, storage and staging of the Garland materials in your price
2.  The General Contractor is responsible for paying the freight associated with the Garland roof system materials.
  - a. Remove any associated freight on Garland material from your price
3.  The General Contractor is responsible for paying the sales or use tax on the Garland roof system materials.
  - a. Do not include sales and use tax , if applicable, for the Garland Roof System Materials in your price
  - b. Include all other materials not supplied by the General Contractor, as well as, the costs, freight, and sales or use taxes associated with them.
4.  The General Contractor is providing Performance and Payment Bonds if the project is awarded.
  - a. Do not include the costs of performance and payment bonds in your price.



**Garland/DBS, Inc.**  
**3800 East 91st Street**  
**Cleveland, OH 44105**



**Return this Worksheet To:**      [dbsbids@garlandind.com](mailto:dbsbids@garlandind.com)      or      (216) 883-2055 (Fax)

**Submission of this form acknowledges receipt and acceptance of:**

1. All standard Garland details and specifications.
2. Prevailing Wage Rates; if applicable
3. Project specific specifications, drawings, and details.
4. Subcontractor is responsible for purchase of Garland and non Garland materials.

**Please note:** Shingles and color boards are to be shown to the client by the Subcontractor for selection.

5. All on-site tradesmen must have a background check and valid I-9 certificates on file. These documents for review upon request.
6. Default payment terms are 2% at 10 days, Net 45 Days
7. DBS will purchase Garland Material based on the material quantities provided herein. Additional Garland Materials or other manufacturer's materials necessary to complete the project will be the Subcontractor's obligation.
8. Proposal bonds are **not** required from the Subcontractor for this project.
9. Performance and Payment bonds will be provided by DBS and are **not** the Subcontractor's responsibility.
10. Workmanship Warranties will **not** extend beyond five (5) years.

**Submit with this Project Cost proposal:**

1. Garland Material List with all quantities, unit sizes, & coverage rates (Subcontractors are responsible to obtain material lists, data sheets, and product costs from Garland Rep)
2. Any qualifications/exclusion to Subcontractor's price proposal.

**Awarded subcontractor must submit:**

1. Site Specific Safety Plan and OSHA 300 log.
2. Equipment list and selected Waste Hauler's License (State or Local).
3. Certificate of Insurance – listing Garland/DBS, Inc. and the project Owner as additional insured's.
4. All licenses and permits.
5. Tax exempt status and sales tax requirements.

<b>CONTRACTOR'S NAME:</b>			
<b>ADDRESS (CITY, STATE, &amp; ZIP CODE):</b>			
<b>TELEPHONE:</b>		<b>CELL:</b>	
<b>CONTACT PERSON:</b>			
<b>CONTACT E-MAIL ADDRESS:</b>			
<b>PROJECT NAME:</b>	Kendall County Courthouse		
<b>ADDRESS (CITY, STATE, &amp; ZIP CODE):</b>	807 John St. Yorkville, IL 60560		
<b>Total Labor \$:</b>			
<b>GARLAND REPRESENTATIVE:</b>	Shawn Browning		
<b>PROJECT SQUARE FOOTAGE:</b>	Approx: 4500 sq ft		



Garland/DBS, Inc.  
3800 East 91st Street  
Cleveland, OH 44105



Return this Worksheet To: [dbsbids@garlandind.com](mailto:dbsbids@garlandind.com) or (216) 883-2055 (Fax)

CONTRACTOR'S NAME:

DBS PROPOSAL #:

**SUBCONTRACTOR AFFIRMATION:**

Does your proposal comply with Garland's standard published application procedures?

YES  NO

Does your proposal comply with Garland's standard published details?

YES  NO

Is your proposal based upon DBS's Continuing Services Agreement?

YES  NO

Is your proposal based upon DBS Inc's General Conditions & Acknowledgements (Page1)?

YES  NO

**SUBCONTRACTOR CLASSIFICATION (Check All That Apply):**

- Minority Owned Business
- Women-Owned Business (WOB)
- Small Business
- Large Business (None of the Above)
- Alaskan Native Tribal-Owned Business
- Veteran-Owned Business (VOB)
- Service-Disabled VOB
- HUBZone Business
- 8(a) Certified Business
- Native American Tribal-Owned Business

**PROPOSAL BREAKDOWN BY KEY COMPONENTS:**

NON-GARLAND ROOF MATERIALS:

ROOFING LABOR (include profit):

Alternate 1 Roofing Labor and non garland materials:

Alternate 1 Roofing Labor and non garland materials:

PERMITS:

SALES TAX - NON-GARLAND MTLs:

TOTAL SUBCONTRACTOR PROPOSAL PRICE :

GARLAND MATERIALS BY DBS:



Garland/DBS, Inc.  
3800 East 91st Street  
Cleveland, OH 44105



Return this Worksheet To: [dbsProposals@garlandind](mailto:dbsProposals@garlandind) or (216) 883-2055 (Fax)

CONTRACTOR'S NAME:

DBS PROPOSAL #:

SUBCONTRACTOR QUOTE MUST BE GOOD FOR 120 DAYS. IF SUBCONTRACTOR CAN HOLD PRICING FOR LONGER, PLEASE FILL-IN TOTAL NUMBER OF DAYS:

DAYS

PROPOSALS WILL BE EVALUATED ON A COMBINATION OF THE BASE PROPOSAL PROPOSAL, RESPONSIVENESS TO THE PROPOSAL DOCUMENTS, AND MARK-UP FOR UNANTICIPATED CHANGE ORDERS, PLEASE PROVIDE YOUR CHANGE ORDER MARK-UPS BELOW:

OVERHEAD

PROFIT

**PROJECT DETAILS & MEASUREMENTS:**

Total Roof Square Footage:

# of Roof Areas:

Roof Height (# of Stories):

# of Roof Drains:

Roof Deck Type:

Square Footage of Flashings:

# of Scuppers:

# of Roof Penetrations:

Current Roof Slope:

# of Roof Levels:

Anticipated Working Days:

Anticipated Start Date:





**Garland/DBS, Inc.**  
**3800 East 91st Street**  
**Cleveland, OH 44105**



**Return this Worksheet To:** [dbsbids@garlandind.com](mailto:dbsbids@garlandind.com) or (216) 883-2055 (Fax)

**CONTRACTOR'S NAME:**

**DBS PROPOSAL #:**

**LINE ITEM PRICING FOR ANTICIPATED UNFORESEEN SITE CONDITIONS:**

<i>LINE ITEM DESCRIPTION</i>	<i>PRICE PER UNIT</i>	<i>UNIT SIZE</i>
Drain replacement		
Soil Stacks		
Additional Insulation replacement		
Rubber boot Replacement		
Pipe support replacement		

**CERTIFICATION OF PROPOSAL INFORMATION:**

I certify that I have reviewed and stand behind our Cost Proposal and Garland material quantities. I have incorporated the application procedures, project details and specifications, Continuing Service Agreement, and insurance requirements, in their entirety, into our cost proposal. This Cost Proposal includes all costs necessary to complete this project.

**Contractor Name:**

**Responsible Party's Name & Title:**

**Responsible Party's Signature:**





### 3 Prevailing Wage Requirements

This project requires the use of Kendall County Prevailing Wages Rates as per the accordance with the Illinois Prevailing Wage Act (Illinois Compiled Statutes, Chapter 820, par. 130-1 to 130-12 ).



## **CONTINUING SERVICES AGREEMENT BETWEEN CONTRACTOR AND SUBCONTRACTOR FOR PROJECTS**

THIS AGREEMENT made this 22nd day of February, 2022 between Garland/DBS and the awarded subcontractor.

**CONTRACTOR:** Garland/DBS, Inc.  
3800 East 91<sup>st</sup> Street  
Cleveland, OH 44105

**SUBCONTRACTOR:**

For services in connection with Contractor's Projects under this Continuing

Services Contract. All notice to the parties shall be given at the above address.

The term of the Agreement shall be the twelve (12) consecutive month's period following the proper execution of the Agreement, with an option for an additional twelve (12) months renewal term, if so agreed in writing by both parties.

### **ARTICLE 1 DEFINITIONS**

- 1.1 Agreement: means this continuing services contract and general conditions for the completion of the Contractor's minor construction projects where the basis of payment is the cost of the work plus Subcontractor's overhead and profit, not to exceed twenty (20%) percent.
- 1.2 Architect/Engineer: means the licensed architect, architect/engineer or engineer, and its consultants, retained by the Contractor to perform design services for the Project on behalf of the Contractor.
- 1.3 Change Order: means work, or performance schedule criteria that is different from the original scope-of- work.
- 1.4 Contract Documents: consist of this Agreement, the drawings, specifications, exhibits, attachments and Contractor issued Purchase Orders as they relate to the Work.
- 1.5 Contractor: is the independent contractor person or entity identified in this Agreement and includes the Contractor's Representative.
- 1.6 Day: means work day during the Contractor's normal hours of operation unless otherwise specifically defined.
- 1.7 Defective Work: is any portion of the Work that is not in conformance with the Contract Documents.



- 1.8 Material Supplier: is a person or entity retained by the Contractor and/or Subcontractor to provide material and/or equipment for the Work.
- 1.9 Others: means other contractors, material suppliers and persons at the Work Site who are not employed by the Contractor and/or Contractor's subcontractors.
- 1.10 Owner: is the person, or entity that owns the real property at the work site for which the work is being performed, and includes the Owner's Representative.
- 1.11 Contractor's Project Criteria: the scope-of-work developed by or for the Owner describing the Contractor's design and construction requirements and objectives for the Project, including budgetary and time constraints, submittal requirements and other requirements governing the Subcontractor's performance of the Work. Contractor's Project Criteria may include conceptual estimates, conceptual schedule and other Project-specific technical materials and requirements needed to define the scope-of-work.
- 1.12 Project: is the project and/or subproject scope-of-work defining the improvements required by the Owner, including budgetary and time criteria for each Project issued by individual Purchase Order from the Contractor for which the Subcontractor is to perform Work under this Agreement.
- 1.13 Performance Schedule: is the document prepared by the Contractor that specifies the dates on which the Subcontractor plans to begin and complete various parts of the Work, including dates which information and approvals are required from the Owner.
- 1.14 Subcontractor: is a person or entity retained by the Contractor as an independent contractor to provide labor, materials, equipment and/or services necessary to complete a specific portion of the Work. The term Subcontractor does not include the architect/engineer.
- 1.15 Substantial Completion: the date when the Work is sufficiently complete in accordance with the Contract Documents so that the Owner can use or utilized the Work for which it is intended.
- 1.16 Sub-subcontractor: is a person or entity that has an agreement with a Subcontractor to perform any portion of the Work.
- 1.17 Work: means all planning, design, construction and other services necessary or incidental to fulfill the scope-of-work defined by the Contractor's individual Purchase Order for a specific Project in accordance with this Agreement and the other Contract Documents. The Work may refer to the whole Project or only a part of the Project if work is also being performed by the Owner or Others.
- 1.18 Work site: means the location where the Work is to be performed.

## **ARTICLE 2 GENREAL PROVISIONS**

- 2.1 Contractor and Subcontractor agree to furnish its best skill and judgment and to proceed with the Projects on the basis of mutual trust, good faith and fair dealing. Contractor and Subcontractor shall endeavor to promote harmony and cooperation among all Project participants.
- 2.2 Subcontractor agrees to comply with all required licenses, permits and inspections as required by the authority having jurisdiction over the Work.



- 2.3 Subcontractor represents that it is an independent contractor and that in its performance of the Work it shall act as an independent contractor.
- 2.4 Neither Subcontractor nor any of its agents or employees shall act on behalf of or in the name of the Contractor or Owner except as provided in the Agreement or unless authorized in writing by Contractor's Representative.
- 2.5 Contractor and Subcontractor will work as a team through the planning and construction phases of the Project.
- 2.6 Contractor reserves the right to inspect and audit Subcontractor's records pertaining to the Project, before, during and up to eighteen (18) months after completion of this contract.
- 2.7 This Agreement is solely for the benefit of the parties, represents the entire and integrated agreement between the parties, and supersedes all prior negotiations, representations or agreements, either oral or written. This Agreement and each and every provision thereof are for the exclusive benefit of the Contractor and Subcontractor and not for the benefit of any third party except to the extent expressly provided in this Agreement.
- 2.8 Where this Agreement is silent, the requirements of the plans and specifications will prevail.  
This Agreement may be amended only by written instrument signed by the Contractor and the Subcontractor.
- 2.9 All Contract Documents related to the Purchase Order, any Change Order to the Purchase Order, the Purchase Order and any correspondence related to the Work shall be identified by the GCI Contract Number for this Agreement.

### **ARTICLE 3 PAYMENT**

- 3.1 Subcontractor's basic services under the Agreement shall include all labor, tools, materials, equipment and all other incidentals necessary to provide a completed sub-project with workmanship of the highest quality by industry standards. Construction services for Projects shall be provided on a sub-project bases, which will be executed by Contractor Purchase Order(s) for each Sub-Project. The Purchase Order(s) shall be considered part of the Contract Documents. Subcontractor shall submit a cost proposal for each Sub- Project. Should the Contractor and Subcontractor not reach a Price agreement on any Sub-Project, the Contractor reserves the right to cease negotiations with the Subcontractor for that Sub-Project and perform the work by other means without affecting this Agreement or any other Sub-Project.
- 3.2 Contractor shall administer design and construction management phase services as provided by the Contract Documents and the Purchase Order for each individual Sub-Project, which shall define the Scope- of-Work for the Sub-Project.
- 3.3 For each Sub-Project, the Subcontractor shall commence work within ten (10) working days after receipt of the Purchase Order as authorization of Notice to Proceed from the Contractor. Subcontractor shall submit for Contractor's review and approval a schedule-of-values for all of the Sub-Project Work. The Schedule- of-Values will: (a) subdivide the Work into its respective parts, (b) include values for all items comprising the Work, including but not limited to general conditions, and (c) serve as the basis for progress payments made to Subcontractor throughout the work.



- 3.4 On or before the 25<sup>th</sup> day of the month, Subcontractor shall submit for Contractor's review and approval its Application for Payment requesting payment for all Work performed and projected through to the end of the month. The Application for Payment shall be accompanied by an updated Schedule-of-Values. Subcontractor Application and Certification for Payment received by the Contractor after the 25<sup>th</sup> of the month shall not be process for payment until the next months pay application submission to the Owner. Notwithstanding anything to the contrary in the Contract Documents, Contractor shall pay Subcontractor all undisputed amounts in an Application for Payment no later than the 25<sup>th</sup> day of the following month..
- 3.5 The Application for Payment may not request payment for equipment and materials not yet incorporated into the Project.
- 3.6 Subcontractor shall not bill for defective work until the work has been re-inspected and accepted by the Contractor.
- 3.7 The Application for Payment shall constitute Subcontractor's representation that the Work has been performed consistent with the Contract Documents; and has progressed to the point indicated in the Application for Payment.
- 3.8 Payment hereunder will not be evidence of or construed to be proper performance or progress of the Work.
- 3.9 On or before the date established in Sections 3.3 and 3.4 of this Agreement, Contractor shall pay Subcontractor all amounts properly due. If Contractor determines that Subcontractor is not entitled to all or part of an Application for Payment, Contractor will notify Subcontractor in writing at least five (5) days prior to the date payment is due. The notice shall indicate the specific amounts Contractor intends to withhold, the reasons and contractual basis for the withholding, and the specific measure Subcontractor must take to rectify Contractor's concerns. Subcontractor will attempt to resolve Contractor's concerns prior to the date payment is due. If the parties cannot resolve such concerns, Contractor may pursue its rights under the Contract Documents.
- 3.10 If Contractor fails to pay Subcontractor any undisputed amount that becomes due, Subcontractor, in addition to all other remedies provided in the Contract Documents or at law, may stop Work after proper notification to the Contractor that a problem exists. Proper notification shall be defined as; Subcontractor must provide Contractor with written notice, served by certified mail to Contractor, defining the problem that exists and the Subcontractor's intent to stop work. If Contractor does not cure the problem within a ten (10) day period, Subcontractor must provide Contractor with written notice, served by certified mail to Contractor of Subcontractor's intent to stop work. If Contractor does not cure the problem within an additional ten (10) day period, Subcontractor may stop work. In such case, Subcontractor may be entitled to make a claim for adjustment to the Contract Price and Contract Time(s) to the extent it has been adversely impacted by such stoppage, provided that the Contractor is solely responsible for failure to make payment to Subcontractor.
- 3.11 Subcontractor shall not stop work for reason of payments withheld in whole or in part, or for failure of the Contractor to make payment to the Subcontractor for applications for payment submitted after the 25<sup>th</sup> of the month, or for disputes as identified in Article 13.
- 3.12 Subcontractor shall not stop work for reason of payments withheld in whole or in part for extra work performed by Subcontractor without a properly executed Change Order to the Purchase Order.



- 3.13 As a condition for payment and in addition to Contractor's receipt of a Final Application for Payment for the Sub-Project, Subcontractor shall provide the following information:
1. An affidavit that there are no claims, obligations or liens outstanding or unsatisfied for labor, services, material, equipment, taxes or other items performed, furnished or incurred for or in connection with the Work which in any way affect Contractor's interests.
  2. A general release executed by Subcontractor waiving, upon receipt of final payment by Subcontractor, all claims, except those claims previously made to Contractor and remaining unsettled at the time of final payment.
  3. If applicable, consent of Subcontractor's surety to final payment.
  4. All operating manuals, warranties and other deliverables required by the Contract Documents.
- 3.14 The acceptance by Subcontractor of the final payment under this Subcontract Agreement shall constitute and operate as a release to Owner and indemnity for all claims and liabilities to Subcontractor, its representatives, subcontractors, and assigns as well as for any additional compensation or payment related to any and all things done or furnished with respect to the services rendered by Subcontractor under, or in connection with, this Subcontract Agreement. However, final payment shall in no way relieve the Subcontractor of liability for its obligations or for faulty or defective work discovered after final payment.

The final payment shall be due within forty (40) days after all of the conditions precedent required under this section have been satisfied.

#### **ARTICLE 4 TIME**

- 4.1 Subcontractor agrees that it will commence performance of the Work and achieve the Contract Time(s) in accordance with the Sub-Project Purchase Order..
- 4.2 If Subcontractor is delayed in the performance of the Work due to acts, omissions, conditions, events, or circumstances beyond its control, the Contract Time(s) for performance shall be reasonably extended by Change Order to the Purchase Order. By way of example, events that will entitle Subcontractor to an extension of the Contract Time(s) include, but not limited to, acts or omissions of Owner or anyone not under Contractor's control (including separate contractors), changes in the Work, Differing Site Conditions, Hazardous Conditions, wars, fires, floods, labor disputes, unusual delay in transportation, epidemics, earthquakes, adverse weather conditions not reasonably anticipated, and other acts of God.
- 4.3 Owner Caused Delay: Contractor shall not be obligated or liable to Subcontractor for payment or extension of time due to Owner caused delays beyond the extent of recovery by the Contractor from the Owner in the form of a properly executed Change Order in accordance with Article 5 of the Agreement.
- 4.4 Subcontractor shall notify Contractor when it believes the Work or the extent permitted in the Contract Documents, a portion of the Work, is substantially completed. Within five (5) days of Contractor's receipt of Subcontractor's notice, Contractor and Subcontractor will jointly inspect such Work to verify that it is substantially completed in accordance with the Contract Documents and prepare the Contractor's Punch- List to the Subcontractor. If Contractor determines that such Work is substantially completed, Subcontractor shall submit Final Application for Payment.





- 4.5 Upon Substantial Completion of the entire Work or, if applicable, any portion of the Work, Contractor shall release Subcontractor all retained amounts related, as applicable, to the entire Work or completed portion of the Work, less any amount equal to the reasonable value of all remaining or incomplete items of Work as noted in the Contractor's Punch-List to the Subcontractor.

## **ARTICLE 5 CHANGES TO THE CONTRACT PRICE AND TIME**

- 5.1 A Change Order to the Purchase Order is a written instrument issued after execution of the Agreement signed by Owner and Contractor, stating their agreement upon all of the following:
- .1 The scope of the change in the Work.
  - .2 The amount of the adjustment to the Contract Price.
  - .3 The extent of the adjustment to the Contract Time(s).
- 5.2 All changes in the Work authorized by applicable Change Order shall be performed under the applicable conditions of the Contract Documents. Contractor and Subcontractor shall negotiate in good faith and as expeditiously as possible the appropriate adjustments for such changes.
- 5.3 Subcontractor shall not make change or any addition to the work except upon receipt by the Contractor of a signed Change Order to the Purchase Order from the Contractor authorizing such a change or addition. No claims for an extra to the contract price shall be valid unless so authorized
- 5.4 The increase or decrease in the Purchase Order/Contract Price resulting from a change in the Work shall be determined by one or more of the following methods:
- .1 Unit prices subsequently agreed to between parties.
  - .2 Lump sum price, mutually agreed to between parties.
  - .3 Cost, fees, and other markups mutually agree to between parties.
- 5.5 In any emergency affecting the safety of persons and/or property, Subcontractor shall act, at its discretion, to prevent threatened damage, injury or loss. Any change in the Purchase Order/Contract Price and/or Contract Time(s) on account of emergency work shall be determined as provided in this Article 5.4.
- 5.6 Change orders shall be prepared by the Subcontractor and submitted to the Contractor along with backup documentation to include, but not limited to, material, labor, equipment, tools, taxes, insurance, and all incidentals to provide a complete and working systems.
- 5.7 The Contractor shall be the only party authorized to request the Subcontractor to perform extra work in accordance with Article 5 of the Agreement. Any extra work performed by the Subcontractor prior to receiving a properly executed Change Order shall be considered incidental and no adjustments will be made to the Subcontract Amount or Time.



- 5.8 If Contractor and Subcontractor disagree upon whether Subcontractor is entitled to be paid for any services required by Owner, or if there are any other disagreements over the Scope-of-Work or proposed changes to the Work, Contractor and Subcontractor shall resolve disagreement pursuant to Article 13 hereof.

#### **ARTICLE 6 LEGAL REQUIREMENTS**

- 6.1 Subcontractor shall perform the Work in accordance with all Legal Requirements and shall provide all notices applicable to the Work as required by the Legal Requirements.
- 6.2 Subcontractor and sub-subcontractors shall comply with all Legal Requirements relating to safety, as well as any Owner-specific safety requirements set forth in the Contract Documents, provided that such Owner-specific requirements do not violate any applicable Legal Requirements. Subcontractor will immediately report any safety-related injury, loss damage or accident arising from the Work to the extent mandated by Legal Requirements, to Contractor and all government or quasi-government authorities having jurisdiction over safety-related matters involving the Project or the Work.
- 6.3 This Agreement is executed in the state where the Contractor's office set forth on page one is located and will be interpreted in accordance with the laws of that state.

#### **ARTICLE 7 GOVERNMENT COMPLIANCE, APPROVALS AND PERMITS**

- 7.1 Subcontractor shall give notices, pay all fees, permits and comply with all laws, ordinances, rules and regulations bearing on the conduct of work.
- 7.2 Subcontractor shall obtain and pay for all government charges and inspection fees required for the execution of the Work by any government or quasi-government entity having jurisdiction over the Project. Contractor shall reimburse Subcontractor for direct costs associated with obtaining such government charges and inspection fees.
- 7.3 All state and local licenses will be required by Subcontractor and Sub-Subcontractors prior to commencement of the work. Subcontractor shall provide Contractor with a current copy of all licenses at the time that the Purchase Order for the Sub-Project is executed.
- 7.4 Subcontractor shall conform to the requirements as designated by the United States Federal Governments, Occupational Safety and Health Administration (O.S.H.A).
- 7.5 If Subcontractor or their sub-subcontractors on the site use hazardous substances which by law would have required the employer to notify its employees, they shall, prior to harmful exposure of any employee to such substance, give written notice of the chemical composition thereof in sufficient detail and provide proper employee training to employees to comply with such laws.
- 7.6 Subcontractor must comply with all state, federal and local taxes. Subcontractor accepts sole and exclusive responsibility for any and all state and federal taxes with respect to Social Security, old age benefits, unemployment benefits, withholdings taxes, sales taxes, and worker's compensation premiums.



---

**ARTICLE 8**  
**SUBCONTRACTOR'S RESPONSIBILITIES**

- 8.1 Unless otherwise provided in the Contract Documents imputing the responsibility to Owner, a separate contractor or others, Subcontractor shall provide through itself the necessary supervision, labor, inspections, material, equipment, machinery, and temporary facilities to permit Subcontractor to complete the Project consistent with the Contract Documents.
- 8.2 Subcontractor shall abide by all rules created by the Owner. Subcontractor must contract the Contractor for specific information regarding the rules governing all operations of the project.
- 8.3 Subcontractor acknowledges receipt of the contract documents, to include but not necessarily limited to the Sub-Project Purchase Order, Project Manual, and/or plans and specifications.
- 8.4 The Project Manual shall contain Supplemental Conditions that are job specific and incorporated as a contract document by reference to this Agreement.
- 8.5 The Subcontractor accepts responsibility for the visual inspection of conditions that could affect the Subcontractor's Work at the Project site, and based on that inspection acknowledges its responsibility to satisfactorily perform the Subcontractor's Work without additional expense to the Contractor. The Subcontractor shall promptly report any discrepancies between its observations and the Contract Documents to the Contractor.
- 8.6 Subcontractor shall perform all construction activities efficiently. Subcontractor shall supply trained workmen with the requisite expertise, skill and competence, in proper numbers, including scheduling and laying out the work, so that the Work will be started and completed in a professional manner to satisfy the requirements of the Contract Documents.
- 8.7 Subcontractor shall be solely responsible for the accuracy of all measurements and for estimating the material quantities required to satisfy the contract documents, plans and specifications. Drawings provided are for reference only, quantities must be field verified prior to providing Subcontractor's pricing to Contractor.
- 8.8 Location of any and All Temporary Facilities must be approved by the County Representative, such as storage sheds, water, heat, light, power, toilets, hoists, elevators, scaffolding, cold weather protection, ventilation, pumps, watchman service, etc., required in performing the work will be furnished by Subcontractor unless otherwise provided for by Contractor and identified in the Contract Documents.
- 8.9 In connection with its furnishing of temporary facilities indicated, Contractor shall not be liable for conditions beyond the control of Contractor, which may interrupt, delay or otherwise interfere with the availability of such facilities to Subcontractor. Unless otherwise expressly indicated, the temporary facilities furnished by Contractor will not be for the exclusive use of Subcontractor, but will be shared by others performing work in the Project. Contractor, therefore, reserves the exclusive right to schedule the use of any facilities in accordance with its determinations as to the needs of the Project, and will incur no liability as a result thereof.
- 8.10 If either party from time to time furnishes the other a crane, hoisting equipment or other machinery or equipment, with or without an operator, for such party's exclusive use, then the using party will at all times furnish adequate and competent supervision and direction therefore and will be fully liable and responsible for safe and proper care, use and custody of such machinery and equipment.



- 8.11 Subcontractor assumes responsibility to Contractor for proper performance of the Work of Subcontractor's employees, vendors and sub-subcontractors and any acts and omissions in connection with such performance. Nothing in the Contract Documents is intended or deemed to create legal or contractual relationship between Contractor and any vendor, equipment provider, material supplier or sub- subcontractor, including but not limited to any third party beneficiary rights.
- 8.12 Subcontractor shall not subcontract any of the Work without prior written approval from the Contractor.
- 8.13 Subcontractor shall coordinate the activities of all employees of Subcontractor and sub-subcontractors. If Contractor performs other work on the Project or at the Site with separate subcontractors under Contractor's control, Subcontractor agrees to reasonably cooperate and coordinate its activities with those of such separate contractors so that the Project can be completed in an orderly and coordinated manner without unreasonable disruption.
- 8.14 Subcontractor shall keep the Work Site reasonably free from construction materials not incorporated into the Work, debris, trash and construction waste to permit Subcontractor to perform its construction services efficiently, safely and without interfering with the use of adjacent land areas. Upon completion of the days Work, Subcontractor shall remove all debris, trash, construction waste, materials, equipment, machinery and tools arising from the Work or applicable portion thereof to permit Owner the use of the Project for its intended purpose.
- 8.15 If the Subcontractor refuses at any time to remove the debris and left over construction materials from the premises, or to keep the working area clean, such cleaning and disposal will be completed by the Contractor and deducted from the balance due the Subcontractor.
- 8.16 All materials shall be stored and protected against weather, vandalism, and theft. Any materials found to be damaged or missing shall be replaced by the Subcontractor at no cost to the Contractor.
- 8.17 Contractor will not be liable or responsible for loss or damage to the equipment, tools, facilities, scaffolds or other personal property owned, rented or used by Subcontractor, or its agents, employees or servants, in the performance of the Work. Subcontractor will maintain such insurance and will take such protective action as it deems desirable with respect to such property. Contractor will not be liable or responsible for any loss or damage to the Work, and Subcontractor will be responsible for the correction or restoration of any such loss or damage to the Work or to the work of Contractor or any other subcontractor, resulting from the operations or activities of Subcontractor, or its subcontractors, agents, employees or servants hereunder.
- 8.18 Subcontractor shall take necessary precautions to protect the Work of others from loss or damage. Should the Subcontractor cause damage to the Work or property of the Owner, the Contractor or others, the Subcontractor shall promptly remedy such damage to the satisfaction of the Contractor, or the Contractor may remedy the damage and deduct its cost from any amounts due or to become due the Subcontractor, unless such costs are recovered under applicable property insurance.
- 8.19 Subcontractor shall protect all grounds, copings, pavings and exterior of all buildings where work will be performed.
- 8.20 Subcontractor shall protect the Owner's facility from water infiltration. Damage caused by water infiltration resulting from the failure of Subcontractor to secure each day's work in a weather tight manner, will be corrected at the Subcontractor's expense. Included as damages will be all labor costs incurred by the Owner as a result of such water infiltration.

- 
- 8.21 The Contractor may direct the Subcontractor to uncover portions of the Subcontractor's Work for inspection by the Contractor at any time. The Subcontractor is required to uncover such work whether or not the Contractor or Owner had requested to inspect the Subcontractor's Work prior to it being covered. Except as provided in the paragraph above, this Agreement shall be adjusted by change order for the cost and time of uncovering and restoring any work which is uncovered for inspection and proves to be installed in accordance with the Subcontract Documents, provided the Contractor had not previously instructed the Subcontractor to leave the work uncovered. If the Subcontractor uncovers work pursuant to a directive issued by the Contractor, and such work upon inspection does not comply with the Subcontract Documents, the Subcontractor shall be responsible for all costs and time of uncovering, correcting and restoring the work so as to make it conform to the Subcontract Documents. If the Contractor or some other entity for which the Subcontractor is not responsible caused the nonconforming condition, the Contractor shall be required to adjust the Sub-Project Purchase Order by Change Order for all such costs and time.
- 8.22 Subcontractor shall promptly remove any work that does not meet the requirements of the contract documents, plans and specifications or is incorrectly installed or otherwise disapproved by the Contractor's Representative as failing to meet the intent of the contract documents, plans and specifications. Subcontractor shall promptly replace and such work without expense to the Contractor and shall bear the cost of making good all work of other subcontractors, or the Owner, destroyed by such removal or replacement.
- 8.23 Acceptability of completed work will be based on Subcontractor's work conformance to the contract requirements. Contractor shall not be responsible for Subcontractor's errors or omissions.
- 8.24 If Contractor deems it unacceptable to have Subcontractor correct work that has been incorrectly done, a deduction from the Sub-Project Purchase Order Price shall be agreed upon therefore. Such a deduction from Purchase Order price shall in no way affect Subcontractor's responsibility for defects that may occur nor Subcontractor's ability for correcting them, and damage caused by them.
- 8.25 Subcontractor is required to cooperate with the hierarchy of construction sequencing and coordinate their activities to not interfere with Contractor's work and/or Contractor Subcontractor's Work to enable Contractor to timely complete the Project Work consistent with the Contract Documents.
- 8.26 Subcontractor shall plan and conduct the operations of the work so that each section started on one day is complete and thoroughly protected before the close of work for that day.
- 8.27 If Owner or any other person or entity asserts a claim or institutes a suit, action or proceeding against Contractor involving the manner or sufficiency of the performance of the Work, upon request of Contractor, Subcontractor will promptly assume the defense of such claim, suit, action, or proceeding, at Subcontractor's sole expense, and Subcontractor will indemnify and hold harmless Contractor and its agents, employees and servant, from and against liability, loss, damage or expense (including attorney's fees, expert witness fees, court cost, and similar costs) arising out of or relating to such claim, suit, action or proceeding.
- 8.28 Subcontractor agrees that One Hundred Dollars and No/Cents (\$100.00) of the Sub-Project Purchase Order Price constitutes the separate consideration for Subcontractor's indemnity pursuant to the provisions and payment paid in the first application for payment.



- 8.29 Subcontractor acknowledges that Contractor has a zero tolerance policy regarding substance abuse, profane language and harassment by Subcontractor's employees and/or sub-subcontractors. Subcontractor shall immediately remove from Work Site any employee and/or sub-subcontractor that Contractor's Representative deems to be disruptive to the work environment and/or objectionable to the Owner's Representative.

## **ARTICLE 9 WARRANTY**

- 9.1 Subcontractor warrants to Contractor and Owner that the construction, including all materials and equipment furnished as part of the construction, shall be new unless specified in the Contract Documents, of good quality, in conformance with the Contract Documents and free of defects in material and workmanship. Subcontractor warranty obligation excludes defects caused by abuse, alterations, or failure to maintain the Work by persons other than Contractor or anyone for whose acts Contractor may be liable. Nothing in this warranty shall provide Owner with greater warranty rights than set forth in this section or the Contract Documents. Subcontractor will provide Contractor, on behalf of the Owner, with all manufacturers' warranties upon Final Completion of the Sub-Project.
- 9.2 Subcontractor agrees to correct any Work that is found to be not in conformance with the Contract Documents, including that part of the Work subject to Section 8.1 hereof, within a period of two years from the date of Substantial Completion of the Work or any portion of the Work, or within such longer period to the extent required by the Contract Documents.
- 9.3 Subcontractor shall guarantee all labor and materials for five (5) years from the date of final payment to the Subcontractor by the Contractor. Subcontractor shall promptly respond to and make repairs during the warranty period in accordance with the terms and conditions of the Manufacturer's material warranty and the contract documents, including any damage done to the Owner's property due to such defects.
- 9.4 Subcontractor shall, within two (2) days of receipt of written notice from Contractor that the Work is not in conformance with the Contract Documents, take meaningful steps to commence correction of such nonconforming Work, including the removal and replacement of the nonconforming Work and any damage caused to other parts of the Work affected by the nonconforming Work.
- 9.5 The five-year period referenced in Section 9.2 above applies only to Subcontractor's obligation to correct nonconforming Work and is not intended to constitute a period of limitations for any other rights or remedies Contractor may have regarding Subcontractor's other obligations under the Contract Documents.

## **ARTICLE 10 CONTRACTOR'S RESPONSIBILITIES**

- 10.1 Contractor shall, throughout the performance of the Work, cooperate with Subcontractor and perform its responsibilities, obligations and services in a timely manner to facilitate Subcontractor's timely and efficient performance of the Work and to prevent delay or interfere with Subcontractor's performance of its obligations under the Contract Documents.
- 10.2 Contractor agrees to furnish planning, design phase, construction administration and management services and to use its best efforts to complete the Projects in an expeditious and economical manner consistent with the interests of the Owner.



- 10.3 Contractor shall provide timely reviews and approvals of interim design submissions and construction documents consistent with the turn-around times set forth in Contractor's performance schedule.
- 10.4 Contractor's Representative shall be responsible for providing Owner-supplied information and approvals in a timely manner to permit Subcontractor to fulfill its obligations under the Contract Documents. Contractor's Representative shall also provide Subcontractor with prompt notice if it observes any failure on the part of Subcontractor to fulfill its contractual obligations, including any errors, omissions or defects in the performance of the Work.
- 10.5 Contractor is responsible for all work performed on the Project or at the Site by separate contractors under Contractor's control. Contractor shall contractually require its separate contractors to cooperate with the hierarchy of construction sequencing, and coordinate their activities to not interfere with the Subcontractor's work to enable Subcontractor to timely complete the Work consistent with the Contract Documents.

#### **ARTICLE 11 HAZARDOUS CONDITIONS AND DIFFERING SITE CONDITIONS**

- 11.1 Unless otherwise expressly provided in the Kendall County Terms and conditions: the Contractor is responsible for arranging a "J.U.L.I.E's" to identify underground utilities that may be compromised by Cranes, Lifts, Scaffolding, ladders, etc. Subcontractor is not responsible for any Hazardous Conditions encountered at the Site. Upon encountering any Hazardous Conditions, Subcontractor will stop Work immediately in the affected area and duly notify Contractor and, if required by Legal Requirements, notify all government or quasi-government entities with jurisdiction over the Sub-Project or Site.
- 11.2 Upon receiving notice of the presence of suspected Hazardous Conditions, Contractor shall notify Owner.  
Owner shall take the necessary measures required to ensure that the Hazardous Conditions are remediated or rendered harmless. Such necessary measures shall include Owner retaining qualified independent experts to: (a) ascertain whether Hazardous Conditions have actually been encountered, and if they have been encountered; and (b) prescribe the remedial measures that Owner must take either to remove the Hazardous Conditions or render the Hazardous Conditions harmless.
- 11.3 Subcontractor shall be obligated to resume Work at the affected area of the Sub-Project only after Owner's expert provides Contractor with written certification that: (a) the Hazardous Conditions have been removed or rendered harmless; and (b) all necessary approvals have been obtained from all government and quasi-government entities having jurisdiction over the Sub-Project or Site. Contractor will provide Subcontractor with written notice to proceed with the work.
- 11.4 Subcontractor will be entitled, in accordance with the terms of this Agreement, to an adjustment in its Contract Price and/or to an adjustment in its Contract Time(s) to the extent Subcontractor cost and/or time of performance have been adversely affected by the presence of Hazardous Conditions.
- 11.5 To the fullest extent permitted by law, Subcontractor shall indemnify, defend and hold harmless Contractor, Design Consultants, Subcontractors, anyone employed directly or indirectly by any of them, and their officers, directors, employees and agents, from and against any and all claims, losses, damages, liabilities and expenses, including attorney's fees and expenses, arising out of or resulting from the presence, removal or remediation of Hazardous Conditions at the Site.



- 11.6 Concealed or latent physical conditions at the Site that: (a) materially differ from the conditions indicated in the Contract Documents; or (b) are of an unusual nature differing materially from the conditions ordinarily encountered and generally recognized as inherent in the Work are collectively referred to and defined herein as "Differing Site Conditions." If Subcontractor encounters a Differing Site Condition, Subcontractor shall immediately notify Contractor. Subcontractor may be entitled to an adjustment in the Contract Price and/or Contract Time(s) to the extent Contractor's cost and/or time of performance are compensated by Owner for the adverse impact by the Differing Site Condition.
- 11.7 Upon encountering a Differing Site Condition and proper notification by Subcontractor to Contractor, Contractor shall provide prompt notice to Owner of such condition, which notice shall not be later than two (2) days after such condition has been encountered. Contractor shall, to the extent reasonably permitted, provide such notice before the Differing Site Condition has been substantially disturbed or altered.

## **ARTICLE 12 INSURANCE AND BONDS**

- 12.1 Subcontractor is responsible for procuring and maintaining from insurance companies authorized to do business in the state in which the Project is located, and with a minimum rating set forth in the Agreement, the following insurance coverages for certain claims which may arise from or out of the performance of the Work and obligations under the Contract Documents:
- .1 Coverage for claims arising under workers' compensation, disability and other similar employee benefit laws applicable to the Work.
  - .2 Coverage for claims by Subcontractor's employee for bodily injury, sickness, disease, or death.
  - .3 Coverage for claims by any person other than Subcontractor's employees for bodily injury, sickness, disease, or death.
  - .4 Coverage for usual personal injury liability claims for damages sustained by a person as a direct or indirect result of Subcontractor's employment of the person, or sustained by any other person.
  - .5 Coverage for claims for damages (other than to the Work) because of injury to or destruction of tangible property, including loss of use.
  - .6 Coverage for claims of damages because of personal injury or death, or property damage resulting from ownership, use and maintenance of any motor vehicle.
  - .7 Coverage for contractual liability claims arising out of Subcontractors obligations under Section 11 hereof.
- 12.2 Subcontractor's liability insurance required by Section 12 above shall be written for the coverage amounts set forth in the Article 12.3 and shall include completed operations insurance for the period of time set forth in the Agreements.





12.3 Subcontractor shall maintain the following insurance:

- (a) Worker's Compensation and Employer's Liability Insurance affording:
  - (1) Protection under the Worker's Compensation Law of the State in which the work is performed must meet or exceed conditions;
  - and
  - (2) Employer's Liability protection subject to a minimum limit of \$1,000,000.
- (b) Comprehensive General Liability Insurance in amounts not less than:  
 Contractual Liability Insurance – to cover the obligations of the Subcontractor with minimum limits as required for Commercial General Liability Insurance.

Products Comp/Ops Aggregate	\$3,000,000
Personal Injury	\$3,000,000 per person (including bodily injury)
Medical Expenses (any one person)	\$5,000 per occurrence
Fire Damage (any one fire)	\$500,000 per occurrence
Property Damage	\$3,000,000 per occurrence

- (c) Comprehensive Automobile Liability Insurance in the following amounts:  
 Automobile Liability Insurance – for all vehicles used in performance of the work, whether owned, hired, or non-owned with minimum limits of \$1,000,000 Combined Single Limit.
 

Bodily Injury	\$1,000,000 per person
	\$1,000,000 per occurrence
Property Damage	\$1,000,000 per occurrence

12.4 The Certificate of Insurance furnished by Subcontractor as evidence of the insurance maintained by Subcontractor shall include a clause obligating the Insurer to give Contractor thirty (30) days prior written notice of cancellation of any material change in the insurance.

12.5 Subcontractor is required to file Certificates of Insurance properly completed and signed by an authorized insurance company representative before their work commences on the job or job site. No monies will be paid to Subcontractor until the acceptable certificates are on file with Contractor.

12.6 Subcontractor's liability insurance set forth in Section 12 shall specifically delete any design-build or similar exclusions that could compromise coverages because of the design-build delivery of the Sub- Project.

12.7 Prior to commencing any construction phase services, Subcontractor shall provide Contractor with certificates evidencing that: (a) all insurance obligations required by the Contract Documents are in full force and in effect and will remain in effect for the duration required by the Contract Documents; and (b) no insurance coverage will be canceled, renewal refused, or materially changed unless written notice is provided to Contractor at least thirty (30) days prior to such change.

12.8 Any loss covered under Subcontractor's property insurance shall be adjusted and made payable to Owner and Contractor as trustees for the insured as their interests may appear. All insurance proceeds received as a result of any loss will be placed in a separate account and distributed in accordance with such agreement as the interested parties may reach. Any disagreement concerning the distribution of any proceeds will be resolved in accordance with Article 13.

## AGREEMENT FORM – STIPULATED SUM

THIS Agreement is entered into the day and year first set forth below between *KENDALL COUNTY, ILLINOIS* (hereinafter “Kendall County”), with its principal place of business at 111 W. Fox St., Yorkville, Illinois, 60560, (hereinafter “Garland Company”), Garland/ DBS with its principal place of business at 3800 E. 91<sup>st</sup> St. Cleveland, OH 44105 and \_\_\_\_\_ (hereinafter referred to as “Subcontractor”) with its principal place of business at \_\_\_\_\_. In consideration of the mutual covenants hereinafter set forth, and other good and valuable consideration, the parties hereto agree as follows:

1. **Effective Date & Term:** This Agreement shall be effective as of its execution and continue until the 2022 Courthouse Roofing Project for Kendall County has been completed or as terminated by either party pursuant to the terms in the Agreement.
2. **The Work:** Contractor will provide Kendall County with construction, labor, materials and services for the 2022 Roofing Project – Courthouse facility for Kendall County in accordance with the following documents (the **Contract Documents**):
  - a. The Drawings, as listed in the Drawing Index, Sheet, prepared by Garland/ DBS Project Manager.
  - b. The Bidding Requirements: Invitation to Bid, Notice to Bidders, and Instructions to Bidders, as incorporated in the Invitation to Bid dated \_\_\_\_\_2022.
  - c. The Bid Form and bid submittals as submitted by the Subcontractor with its bid.
  - d. **The General Requirements, Division 1 and Specification Divisions as contained in the Project Manual, as prepared by the Garland/ DBS Project Manager dated 2022, along with mechanical specifications as noted in the drawing set.**
  - e. The Addenda: Addendum \_\_\_\_\_ dated \_\_\_\_\_, \_\_\_ pages and \_\_\_\_\_ drawings, Addendum # \_\_\_\_\_ dated \_\_\_\_\_, \_\_\_\_\_ pages and \_\_\_\_\_ drawings.
3. **Modifications:** All changes or adjustments to this Agreement, including but not limited to any increase or decrease of the scope of the work performed or adjustment in the Contract Sum and Contract Time, must be in writing, signed by both parties to the Agreement.
4. **Payment:** In consideration for Contractor providing the Work, to the satisfaction of Kendall County, as set forth in this Agreement, Kendall County agrees to pay the Contract Sum of \_\_\_\_\_ Dollars (\$ \_\_\_\_\_), which includes Base bid (\$ \_\_\_\_\_), Project Allowance (\$ \_\_\_\_\_) for \_\_\_\_\_, and Alternate \_\_\_\_\_ to \_\_\_\_\_, \_\_\_\_\_ as shown on the bid drawing \_\_\_\_\_ (\$ \_\_\_\_\_). Subcontractor must present an Application for Payment to Kendall County, attn.: KCFM Director, [kcfm@co.kendall.il.us](mailto:kcfm@co.kendall.il.us) 804 W. John St. Suite B. Yorkville, IL 60560 for certification of the amount due, in accordance with Contract Documents. The total amount due shall be paid in accordance with the Local Government Prompt Payment Act, 50 ILCS 505/1, *et seq.* Kendall County reserves the right to reject any portion of the invoice that is outside the scope of the approved work or outside the scope of any additional approved work.
5. **Time:** The Contractor shall achieve Substantial Completion of the Work by September 30, 2022, and shall achieve Final Completion within 30 calendar days thereafter. Time shall be changed only by written agreements signed by both parties.
6. **Indemnification:** Contractor shall indemnify, hold harmless and defend with counsel of Kendall County’s own choosing, Kendall County, its past, present and future elected officials, department heads, employees, insurers, and agents (hereinafter collectively referred to as “Releases”) from and against all liability, claims, suits, causes of action, demands, proceedings, set-offs, liens, attachments, debts, expenses, judgments, or other liabilities including costs, reasonable fees and expense of defense, arising from any loss, damage, injury, death, or loss or damage to property, of whatsoever kind or nature

as well as for any breach of any covenant in the Agreement or ancillary documents and any breach by Contractor of any representations or warranties made within the contract documents (collectively, the "Claims"), to the extent such Claims result from the performance of this Agreement contract by Contractor or those Claims are due to any act or omission, neglect, willful acts, errors, omissions or misconduct of SubContractor in its performance under this Agreement. Nothing contained herein shall be construed as prohibiting Kendall County, its past, present, and future elected officials, officers, employees, board members, and agents from defending through the selection and use of their own agents, attorneys and experts, any claims, suits, demands, proceedings and actions brought against them. Pursuant to 55 ILCS 5/3-9005, any attorney representing Kendall County, under this paragraph, shall be approved by the Kendall County State's Attorney and shall be appointed as a Special Assistant State's Attorney. Kendall County's participation in its defense shall not remove Contractor's duty to indemnify and hold the Kendall County harmless as set forth above. Kendall County does not waive its defenses or immunities under the Local Government and Government Employee Tort Immunity Act. (745 ILCS 10.1 et seq.) by reason of indemnification or insurance. Indemnification obligations shall survive the termination of this Agreement.

7. **Bonds:** Subcontractor must furnish, supply and deliver a payment bond in the amount of 100% of the Contract Sum to Kendall County pursuant to the requirements of the Public Construction Bond Act, 30 ILCS 550/1 et seq.
8. **Insurance:** Subcontractor will obtain and continue in force, during the term of this Agreement, all insurance as set forth herein. All coverage shall be placed with insurers authorized to conduct business in Illinois with a current A.M. Best's rating of no less than A:VII. Each insurance policy shall not be cancelled or changed without thirty (30) calendar day's prior written notice, given by the insurance carrier to Kendall County & Garland/ DBS at the address set forth herein.

All coverage shall be at least as broad as the following:

Commercial General Liability ("CGL"): Insurance Services Office Form CG 00 01 covering CGL on an "occurrence" basis, including products and completed operations, property damage, bodily injury and personal & advertising injury with limits no less than \$1,000,000 per occurrence. If a general aggregate limit applies, either the general aggregate limit shall apply separately to this project/location (ISO CG 25 03 or 25 04) or the general aggregate limit shall be \$2,000,000.

Umbrella/Excess Liability: Limits of liability equal to or greater than \$5,000,000 per occurrence and \$5,000,000 in aggregate.

Automobile Liability: Insurance Services Office Form Number CA 0001 covering, Code 1 (any auto), or if Contractor has no owned autos, Code 8 (hired) and 9 (non-owned), with limit no less than \$1,000,000 per accident for bodily injury and property damage.

Workers' Compensation Insurance: Insurance as required by the State of Illinois, with Statutory Limits, and Employer's Liability Insurance with limit of no less than \$1,000,000 per accident for bodily injury or disease.

If Contractor maintains broader coverage and/or higher limits than the minimums shown above, Kendall County shall be entitled to the broader coverage and/or the higher limits maintained by Contractor. Any available insurance proceeds in excess of the specified minimum limits of insurance and coverage shall be available to Kendall County.

Kendall County and its, past, present, and future its officers, officials, employees, and volunteers are to be covered as additional insureds on the CGL policy with respect to liability arising out of work or operations performed by or on behalf of Contractor including materials, parts, or equipment furnished in connection with such work or operations. General liability coverage can be provided in the form of

an endorsement to Contractor's insurance (at least as broad as ISO Form CG 20 10 11 85 or both CG 20 10, CG 20 26, CG 20 33, or CG 20 38; and CG 20 37 forms if later revisions used).

For any claims related to this contract, Subcontractor's insurance coverage shall be primary insurance coverage at least as broad as ISO CG 20 01 04 13 with respect to Kendall County, its past present and future officers, officials, employees, and volunteers. Any insurance maintained by Kendall County, its past present or future officers, officials, employees, or volunteers shall be excess of Contractor's insurance and shall not contribute with it.

Subcontractor hereby grants to Kendall County and its, past, present, and future its officers, officials, employees, and volunteers a waiver of any right to subrogation which any insurer of said Subcontractor may acquire against Kendall County by virtue of the payment of any loss under such insurance. Subcontractor agrees to obtain any endorsement that may be necessary to affect this waiver of subrogation, but this provision applies regardless of whether or not Kendall County has received a waiver of subrogation endorsement from the insurer.

If any of the required policies provide coverage on a claims-made basis, (1) the Retroactive Date must be shown and must be before the date of the contract or the beginning of contract work, (2) insurance must be maintained and evidence of insurance must be provided for at least five (5) years after completion of the contract of work, and (3) if coverage is canceled or non-renewed, and not replaced with another claims-made policy form with a Retroactive Date prior to the contract effective date, Subcontractor must purchase "extended reporting" coverage for a minimum of five (5) years after completion of contract work.

Subcontractor shall furnish Kendall County with original Certificates of Insurance including all required amendatory endorsements (or copies of the applicable policy language effecting coverage required by this clause) and a copy of the Declarations and Endorsement Page of the CGL policy listing all policy endorsements to Kendall County before work begins. However, failure to obtain the required documents prior to the work beginning shall not waive Subcontractor's obligation to provide them. Kendall County reserves the right to require complete, certified copies of all required insurance policies, including endorsements required by these specifications, at any time.

Subcontractor shall require and verify that all subcontractors maintain insurance meeting all the requirements stated herein, and Subcontractor shall ensure that Kendall County is an additional insured on insurance required from subcontractors.

9. **Property Damage:** All loss or damage arising out of the nature of the work performed by Subcontractor including, but not limited to any damage caused to Contractor's equipment during the performance of said work shall be sustained at Subcontractor's expense. Subcontractor shall also be held responsible for any and all damage caused by Subcontractor in the performance of services under this Agreement. Any damage caused by Subcontractor to the County's parking lots, islands, sidewalks, buildings, and/or other Kendall County property may be repaired by Kendall County, in its sole discretion, and either deducted from the payment owed to the Subcontractor or billed to General Contractor, at Kendall County's discretion.
10. **Independent Contractor:** Subcontractor is an Independent Subcontractor and is not an employee of, partner of, agent of, or in a joint venture with Kendall County. Subcontractor understands and agrees that Subcontractor is solely responsible for paying all wages, benefits and any other compensation due and owing to Subcontractor's officers, employees, and agents for the performance of services set forth in the Agreement. Subcontractor further understands and agrees that Subcontractor is solely responsible for making all required payroll deductions and other tax and wage withholdings pursuant to state and federal law for Subcontractor's officers, employees and/or agents who perform services as set forth in the Agreement. Subcontractor also acknowledges its obligation to obtain appropriate insurance coverage for the benefit of Subcontractor, Subcontractor's officers, employees and agents

and agrees that Kendall County is not responsible for providing any insurance coverage for the benefit of Subcontractor, Subcontractor's officers, employees and agents. Subcontractor hereby indemnifies and agrees to waive any right to recover alleged damages, penalties, interest, fees (including attorneys' fees), and/or costs from Kendall County, its board members, officials, employees, insurers, and agents for any alleged injuries that Contractor, its officers, employees and/or agents may sustain while performing services under the Agreement.

11. **Non-Appropriation:** In the event Kendall County is in default under the Agreement because funds are not appropriated for a fiscal period subsequent to the one in which the Agreement was entered into which are sufficient to satisfy all or part of the County's obligations under this Agreement during said fiscal period, the County agrees to provide prompt written notice of said occurrence to Subcontractor. In the event of a default due to non-appropriation of funds, Contractor and/or Kendall County has the right to terminate the Agreement upon providing thirty (30) calendar days written notice to the other party. No additional payments, penalties and/or early termination charges shall be required upon termination of the Agreement.
12. **Termination:** Notwithstanding any other provision of this Agreement, this Agreement may be terminated by Kendall County upon written notice delivered to Contractor at least thirty (30) calendar days prior to the effective date of termination. Kendall County shall reimburse Subcontractor for any work completed prior to the termination date. Upon receipt of a termination notice, Subcontractor shall immediately comply with its terms and take all reasonable steps to minimize the costs associated with termination of services. Kendall County shall not be liable for those costs and expenses resulting from Subcontractor's failure to mitigate such losses. Further, Kendall County shall not be responsible for salaries, overhead, and fees accrued after the Agreement's termination. Kendall County shall not be liable for any other additional payments, penalties, and/or early termination charges.
13. **Warranties:** Subcontractor warrants to Kendall County that all construction and related services provided shall be performed in a good and workman like manner, in accordance with the terms of the Contract Documents, and all applicable laws, codes, regulations and other requirements, including safety standards. All services to be undertaken by Contractor shall be carried out by competent and properly trained personnel of Contractor to the highest standards and to the satisfaction of Kendall County. All services, materials and components shall conform to relevant manufacturers' and equipment suppliers' specifications, and all materials and spare parts shall be obtained from the original equipment manufacturers or from suppliers approved by them. No warranties implied or explicit may be waived or denied.
14. **Kotecki Waiver:** General Contractor (and any subcontractor into whose subcontract this clause is incorporated) agrees to assume the entire liability for all personal injury claims suffered by its own employees, asserted by persons allegedly injured on the Project; waives any limitation of liability defense based upon the Worker's Compensation Act, court interpretations of said Act or otherwise; and to the fullest extent permitted by law, agrees to indemnify and hold harmless and defend Kendall County, Illinois and its past, present and future board members, elected officials, employees, agents and consultants (the "Indemnitees") from and against all such loss, expense, damage or injury, including reasonable attorneys' fees, that the Indemnitees may sustain as a result of such claims, except to the extent that Illinois law prohibits indemnity for the Indemnitees' own negligence. Indemnitees are designated and recognized as explicit third-party beneficiaries of the Kotecki Waiver within the general contract and all subcontracts entered into in furtherance of the general contract.
15. **Assignment:** Neither party shall assign, sublet, sell, or transfer its interest in this Agreement without the prior written consent of the other.
16. **Confidentiality:** It is understood and agreed to by Subcontractor that all contracts entered into by a government body, such as Kendall County, are open to public review and as such will be on file with

the County Clerk's office and may be released pursuant to the Illinois Freedom of Information Act (5 ILCS 140, *et seq.*).

17. **Notice:** Any notice required or permitted to be given pursuant to this Agreement shall be duly given if sent by fax, certified mail, or courier service and received, in the case of notice to Kendall County, KCFM, Attention: Director, Facilities Management, 804 John Street, Suite B, Yorkville, Illinois, 60560, fax (630) 553-4125, with copy sent to: State's Attorney, Attention: Eric Weis, 807 John Street, Yorkville, Illinois, 60560, fax (630) 553-4204. And, in the case of Contractor, to \_\_\_\_\_, Phone: (\_\_\_\_) \_\_\_\_\_, Fax: (\_\_\_\_) \_\_\_\_\_.

18. **Force Majeure:** Neither party will be responsible to the other for damage, loss, injury, or interruption of work if the damage, loss, injury, or interruption of work is caused solely by conditions that are beyond the reasonable control of the parties, and without the intentional misconduct or negligence, of that party (hereinafter referred to as a "force majeure event"). To the extent not within the control of either party, such force majeure events include: acts of God, acts of any governmental authorities, fire, explosions or other casualties, vandalism, and riots or war. A party claiming a force majeure event ("the claiming party") shall promptly notify the other party in writing, describing the nature and estimated duration of the claiming party's inability to perform due to the force majeure event. The claiming party with all reasonable dispatch will remedy the cause of such inability to perform.

19. **Certification:** Subcontractor certifies that Subcontractor, its parent companies, subsidiaries, and affiliates are not barred from entering into this Agreement as a result of a violation of either 720 ILCS 5/33E-3 or 5/33E-4 (bid rigging or bid rotating) or as a result of a violation of 820 ILCS 130/1 *et seq.* (the Illinois Prevailing Wage Act).

Subcontractor further certifies by signing the Agreement that Subcontractor, its parent companies, subsidiaries, and affiliates have not been convicted of, or are not barred for attempting to rig bids, price-fixing or attempting to fix prices as defined in the Sherman Anti-Trust Act and Clayton Act. 15 U.S.C. § 1 *et seq.*; and has not been convicted of or barred for bribery or attempting to bribe an officer or employee of a unit of state or local government or school district in the State of Illinois in that Officer's or employee's official capacity. Nor has Subcontractor made an admission of guilt of such conduct that is a matter of record, nor has any official, officer, agent, or employee of the company been so convicted nor made such an admission.

20. **Compliance with State and Federal Laws:** Subcontractor agrees to comply with all applicable federal, state and local laws and regulatory requirements and to secure such licenses as may be required for its employees and to conduct business in the state, municipality, county and location. Such obligation includes, but is not limited to, environmental laws, civil rights laws, prevailing wage laws, and labor laws.
21. **Equal Opportunity/Non-Discrimination:** The General Contractor and any Subcontractors will not discriminate against any employee or applicant for employment because of race, color, religion, sex, ancestry, national origin, place of birth, age or handicap unrelated to bona fide occupational qualifications. Subcontractor, its officers, employees, and agents agree not to commit unlawful discrimination and agree to comply with all applicable provisions of the Illinois Human Rights Act, Title VII of the Civil Rights Act of 1964, as amended, the Americans with Disabilities Act, the Age Discrimination in Employment Act, Section 504 of the Federal Rehabilitation Act, and all applicable rules and regulations.
22. **Prevailing Wage:** This contract calls for the construction of a "public work" within the meaning of the Illinois Prevailing Wage Act, 820 ILCS 130/.01 *et seq.* ("the Act"). The Act requires contractors and subcontractors to pay laborers, workers and mechanics performing services on public works projects no less than the current "prevailing rate of wages" (hourly cash wages plus fringe benefits) in

the county where the work is performed. The Illinois Department of Labor (“Department”) publishes the prevailing wage rates on its website at <http://labor.illinois.gov/>. The Department revises the prevailing wage rates and the contractor/subcontract has an obligation to check the Department’s website for revisions to prevailing wage rates. For information regarding current prevailing wage rates, please refer to the Department’s website. All contractors and subcontractors rendering services under this contract must comply with all requirements of the Act, including, but not limited to, all wage requirements and notice and record keeping duties.

23. **Employment of Illinois Workers on Public Works Act:** If at the time the Agreement is executed, or if during the term of the Agreement, there is a period of excessive unemployment in Illinois as defined in the Employment of Illinois Workers on Public Works Act, 30 ILCS 570/0.01 et seq., (hereinafter referred to as “the Act”), Subcontractor, its consultants, subcontractors and agents agree to employ Illinois laborers on this Project in accordance with the Act. Subcontractor understands that the Act defines (a) “period of excessive unemployment” as “as any month following two consecutive calendar months during which the level of unemployment in the State of Illinois has exceeded 5%, as measured by the United States Bureau of Labor Statistics in its monthly publication of employment and unemployment figures,” and (b) "Illinois laborer" as “any person who has resided in Illinois for at least thirty (30) calendar days and intends to become or remain an Illinois resident.” See 30 ILCS 570/1. Contractor understands and agrees that its failure to comply with this provision of the Agreement may result in immediate termination of the Agreement.
24. **Conflict of Interest:** Both parties affirm no Kendall County officer or elected official has a direct or indirect pecuniary interest in Contractor or this Agreement, or, if any Kendall County officer or elected official does have a direct or indirect pecuniary interest in Contractor or this Agreement, that interest, and the procedure followed to effectuate this Agreement has and will comply with 50 ILCS 105/3.
25. **Remedies:** In any action with respect to this Agreement, the Parties are free to pursue any legal remedies at law or in equity. If Kendall County is required to take legal action to enforce performance of any of the terms, provisions, covenants and conditions of this Agreement, and by reason thereof, Kendall County is required to use the services of an attorney, then Kendall County shall be entitled to reasonable attorneys’ fees, court costs, expenses, and expert witness fees incurred by Kendall County pertaining thereto and in enforcement of any remedy, including costs and fees relating to any appeal.
26. **Waiver:** The Parties' waiver of any term, condition, or covenant or breach of any term, condition, or covenant, shall not constitute a waiver of any other term, condition, or covenant, or the breach thereof.
27. **Background Checks/Security:** Subcontractor shall exercise general and overall control of its officers, employees and/or agents. Subcontractor agrees that no one shall be assigned to perform work at Kendall County’s facilities on behalf of General Contractor, Contractor’s consultants, subcontractors and their respective officers, employees, agents and assigns unless Contractor has completed a criminal background investigation for each individual to be performing work at the site. In the event that the individual’s criminal background investigation reveals that the individual has a conviction record that has not been sealed, expunged, or impounded under Section 5.2 of the Criminal Identification Act, Contractor agrees that the individual shall not be assigned to perform work on or at Kendall County’s facilities absent prior written consent from Kendall County. Kendall County, at any time, for any reason and in Kendall County’s sole discretion, may require General Contractor and/or Contractor’s consultants, and/or subcontractors to remove any individual from performing any further work under this Agreement.

Subcontractor understands, and agrees, that any person who takes into, or out of, or attempts to take into, or out of, a correctional facility, or the grounds belonging to or adjacent to the correctional facility, any item not specifically authorized by the correctional facility, such as contraband, shall be prosecuted. All persons, including employees and visitors, entering upon such premises are subject to routine searches of their persons, vehicles, property and/or packages. Contraband shall include, but not be

limited to, any dangerous drug, narcotic drug, intoxicating liquor, deadly weapon, dangerous instrument, ammunition, explosive or any other article whose use of or possession of would endanger the safety, security or preservation of order in a correctional facility or any persons therein. Company further agrees that it shall notify correctional facility personnel of the loss or breakage of any tools and equipment while within the facility.

28. **MSDS:** When applicable, Subcontractor shall furnish Material Safety Data Sheets for their products, in compliance with the Illinois Toxic Substance Disclosure to Employee Act, Safety Inspection and Education Act & “Right to Know” law, 820 ILCS 255/1 *et seq.*, 820 ILCS 220/0.01 *et seq.* and 820 ILCS 225/0.1 *et seq.*
29. **Counterparts:** This Agreement may be executed in counterparts (including facsimile signatures), each of which shall be deemed to be an original and both of which shall constitute one and the same Agreement.
30. **Waiver of Lien:** Subcontractor hereby waives any claim of lien against subject premises on behalf of Subcontractor, its officers, insurers, employees, agents, suppliers and/or subcontractors employed by this Agreement. Upon completion of the work and as a condition prior to payment in full, Contractor shall tender to Kendall County a final waiver of lien for all subcontractors and/or suppliers.
31. **Occupational Safety and Health Act:** The General Contractor and any Subcontractors shall comply with all the provisions of the Federal Occupational Safety and Health Act of 1970 (84 Stat. 1590), as amended.
32. **Drug Free Workplace:** General Contractor and its consultants, employees, contractors, subcontractors, and agents agree to comply with all provisions of the Substance Abuse Prevention on Public Works Act, 820 ILCS 265/1 *et seq.* and the Illinois Drug Free Workplace Act, 30 ILCS 580/1 *et seq.*
33. **Default:** The Agreement may be canceled or annulled by Kendall County in whole or in part by written notice of default to the Subcontractor upon nonperformance or violation of ITB and/or Agreement’s terms. Failure of the Contractor to deliver services within the time stipulated in its offer, unless extended in writing by Kendall County, shall constitute an Agreement default.
34. **Governing Law & Venue:** This Agreement shall be construed in accordance with the law and Constitution of the State of Illinois and if any provision is invalid for any reason such invalidations shall not render invalid other provisions which can be given effect without the invalid provision. Notwithstanding any other provision to the contrary, venue in all legal proceedings between the parties shall be in the Circuit Court of Kendall County, Illinois, Twenty-Third Judicial Circuit, State of Illinois.
35. **Entire Agreement:** This Agreement, together with the Contract Documents referenced in paragraph 2 above, represents the entire agreement between the parties and there are no other promises or conditions in any other agreement whether oral or written. This Agreement, together with the Contract Documents, supersedes any prior written or oral agreements between the parties and may not be modified except in writing acknowledged by both parties.
36. **Taxes:** Kendall County is exempt from federal excise and transportation taxes. Kendall County is also exempt from payment of Illinois Sales Tax. TAX EXEMPTION IDENTIFICATION NUMBER: E9995-9003-07. The County agrees to notify Contractor promptly in the event of a change in its tax-exempt status. No submitted bids can include any amounts of money for these taxes.
37. **Authority to Execute Agreement:** The Kendall County and Contractor each hereby warrant and represent that their respective signatures set forth below have been and are on the date of this Agreement duly authorized by all necessary and appropriate corporate and/or governmental action to execute this Agreement.





KENDAL0001

SSHOCK

CERTIFICATE OF LIABILITY INSURANCE

DATE (MM/DD/YYYY) 11/27/2018

THIS CERTIFICATE IS ISSUED AS A MATTER OF INFORMATION ONLY AND CONFERS NO RIGHTS UPON THE CERTIFICATE HOLDER. THIS CERTIFICATE DOES NOT AFFIRMATIVELY OR NEGATIVELY AMEND, EXTEND OR ALTER THE COVERAGE AFFORDED BY THE POLICIES BELOW.

IMPORTANT: If the certificate holder is an ADDITIONAL INSURED, the policy(ies) must have ADDITIONAL INSURED provisions or be endorsed. If SUBROGATION IS WAIVED, subject to the terms and conditions of the policy, certain policies may require an endorsement.

PRODUCER: Mesirow Insurance Services, Inc.
INSURED: Kendall County & Kendall County Forest Preserve District
CONTACT NAME, PHONE, FAX, E-MAIL ADDRESS, INSURER(S) AFFORDING COVERAGE, NAIC #, INSURER A-F

COVERAGES CERTIFICATE NUMBER: REVISION NUMBER:

THIS IS TO CERTIFY THAT THE POLICIES OF INSURANCE LISTED BELOW HAVE BEEN ISSUED TO THE INSURED NAMED ABOVE FOR THE POLICY PERIOD INDICATED. NOTWITHSTANDING ANY REQUIREMENT, TERM OR CONDITION OF ANY CONTRACT OR OTHER DOCUMENT WITH RESPECT TO WHICH THIS CERTIFICATE MAY BE ISSUED OR MAY PERTAIN, THE INSURANCE AFFORDED BY THE POLICIES DESCRIBED HEREIN IS SUBJECT TO ALL THE TERMS, EXCLUSIONS AND CONDITIONS OF SUCH POLICIES.

Table with columns: INSR LTR, TYPE OF INSURANCE, ADDL INSD, SUBR WVD, POLICY NUMBER, POLICY EFF (MM/DD/YYYY), POLICY EXP (MM/DD/YYYY), LIMITS. Includes Commercial General Liability, Automobile Liability, Umbrella Liab, Workers Compensation, and E&O or Professional Liability.

DESCRIPTION OF OPERATIONS / LOCATIONS / VEHICLES (ACORD 101, Additional Remarks Schedule, may be attached if more space is required)
Kendall County and its, past, present, and future its officials, employees and volunteers are to be included as additional insureds on the CGL policy...

CERTIFICATE HOLDER: Kendall County
CANCELLATION: SHOULD ANY OF THE ABOVE DESCRIBED POLICIES BE CANCELLED BEFORE THE EXPIRATION DATE THEREOF, NOTICE WILL BE DELIVERED IN ACCORDANCE WITH THE POLICY PROVISIONS. AUTHORIZED REPRESENTATIVE: Must be signed by Authorized Representative

Verify that all of your Illinois Sales Tax Exemption Certificate information is correct

- ✓ If not, contact us immediately.
- ✓ **Do not discard** - your Illinois Sales Tax Exemption Certificate is an important tax document that authorizes you to purchase tangible personal property for use or consumption tax-free.

OFFICIAL DOCUMENT State of Illinois - Department of Revenue OFFICIAL DOCUMENT

### Illinois Sales Tax Exemption Certificate

KENDALL COUNTY

111 W FOX RD  
YORKVILLE IL 60560-1621

### Sales Tax Exemption Certificate

<b>Issue date:</b> 02/10/2020	<b>Sales Tax Exemption</b>	<b>E99959003</b>
<b>Expiration date:</b> 03/01/2025	<b>Organization type:</b>	<b>Governmental</b>

This entity is authorized under the Retailers' Occupation Tax Act to purchase tangible personal property for use or consumption tax-free.

ILLINOIS REVENUE  
*[Signature]*  
Director

OFFICIAL DOCUMENT - DO NOT DESTROY

# Bidder Acknowledgment Form

## Kendall County Rules and Regulations

\_\_\_\_\_  
Contractor Name

\_\_\_\_\_  
Signature

\_\_\_\_\_  
Printed Name

\_\_\_\_\_  
Title

The Garland Company/ DBS

\_\_\_\_\_  
General Contractor Name

*Shawn Browning*  
\_\_\_\_\_  
Signature

Shawn Browning

\_\_\_\_\_  
Printed Name

Territory Manager

\_\_\_\_\_  
Title

---

# 5. EPDM Adhered Specification

## PART 1 GENERAL

### 1.01 DESCRIPTION

- A. The Kendall County Courthouse is located at 807 W. John St. in Yorkville, IL. Shawn Browning, Project Manager/Coordinator, is the General Contractor on behalf of Kendall County and may be contacted regarding any questions regarding the project or Pre-Bid information, phone 331-216-9115.
- B. The project consists of installing Viking Products Group, Inc. EPDM (black) Design "A" Fully Adhered Roofing System as outlined below:

Apply the Fully Adhered EPDM Roofing System in conjunction with existing Polyisocyanurate after tear off of the existing EPDM roof to expose the Polyisocyanurate and adding ½' primed dens deck for verification of suitable substrate as specified in this specification.

### 1.02 EXTENT OF WORK

- A. Provide all labor, material, tools, equipment, and supervision necessary to complete the installation of a EPDM .060 inch thick non-reinforced EPDM membrane Fully Adhered Roofing System including flashings and insulation as specified herein and as indicated on the drawings in accordance with the manufacturer's most current specifications and details.
- B. The roofing contractor shall be fully knowledgeable of all requirements of the contract documents and shall make themselves aware of all job site conditions that will affect their work.
- C. The roofing contractor shall confirm all given information and advise the building owner, prior to bid, of any conflicts that will affect their cost proposal.
- D. No substitutes allowed.

### 1.03 SUBMITTALS

- A. Prior to starting work, the roofing contractor must submit the following:
  - 1. Shop drawings showing layout, details of construction and identification of materials.
  - 2. Sample of the manufacturer's Membrane System Warranty.
  - 3. Submit a letter of certification from the manufacturer which certifies the roofing contractor is authorized to install the manufacturer's roofing system and lists foremen who have received training from the manufacturer along with the dates training was received.
  - 4. Certification of the manufacturer's warranty reserve.
- B. Upon completion of the installed work, submit copies of the manufacturer's final inspection to the specifier prior to the issuance of the manufacturer's warranty.

## **1.04 PRODUCT DELIVERY, STORAGE AND HANDLING**

- A. Deliver materials to the job site in the manufacturer's original, unopened containers or wrappings with the manufacturer's name, brand name and installation instructions intact and legible. Deliver in sufficient quantity to permit work to continue without interruption.
- B. Comply with the manufacturer's written instructions for proper material storage.
  - 1. Store materials, except membrane, between 60°F and 80°F in dry areas protected from water and direct sunlight. If exposed to lower temperature, restore to 60°F minimum temperature before using.
  - 2. Store materials containing solvents in dry, well ventilated spaces with proper fire and safety precautions. Keep lids on tight. Use before expiration of their shelf life.
- C. Insulation must be on pallets, off the ground and tightly covered with waterproof materials.
- D. Any materials which are found to be damaged shall be removed and replaced at the applicator's expense.

## **1.05 WORK SEQUENCE**

- A. Schedule and execute work to prevent leaks and excessive traffic on completed roof sections. Care should be exercised to provide protection for the interior of the building and to ensure water does not flow beneath any completed sections of the membrane system.
- B. Do not disrupt activities in occupied spaces.

## **1.06 USE OF THE PREMISES**

- A. Before beginning work, the roofing contractor must secure approval from the building owner's representative for the following:
  - 1. Areas permitted for personnel parking.
  - 2. Access to the site.
  - 3. Areas permitted for storage of materials and debris.
  - 4. Areas permitted for the location of cranes, hoists and chutes for loading and unloading materials to and from the roof.
  - 5. Temporary facilities will not be available at the job site. The roofing contractor shall be responsible for the provision and maintenance of portable toilets or their equal.
- B. Interior stairs or elevators may not be used for removing debris or delivering materials, except as authorized by the facilities manager or designee.

## **1.07 EXISTING CONDITIONS**

If discrepancies are discovered between the existing conditions and those noted on the drawings, immediately notify the General Contractor for approval prior to commencing with the work. Necessary steps shall be taken to make the building watertight until the discrepancies are resolved.

## **1.08 PRE-CONSTRUCTION CONFERENCE**

- A. A pre-construction meeting will be held at the job site tentative on 7/19/21 at 9am. Contact the owner's representative, Dan Polvere at (630-636-8999) if there are any questions.
- B. Prior to bid submittal, the roofing contractor should schedule a job site inspection to observe actual conditions and verify all dimensions on the roof. The job site inspection may occur on the day of the pre-bid meeting. No

access to the roof after the pre-bid meeting.

- C. Bids must be forwarded to the following address no later than 2pm on 6/30 to Garland/ DBS at [DBSbids@garlandind.com](mailto:DBSbids@garlandind.com)
- D. Conditions which are not shown on the details or drawings should be indicated on a copy of the drawing and included with bid submittal if necessary to clarify any conditions not shown.

## 1.09 TEMPORARY FACILITIES AND CONTROLS

- A. Temporary Utilities:
  - 1. Water, power for construction purposes and lighting (are not) available at the site and (will not) be made available to the roofing contractor.
  - 2. Provide all hoses, valves and connections for water from source designated by the owner when made available.
- B. Building Site:
  - 1. The roofing contractor shall use reasonable care and responsibility to protect the building and site against damages. The contractor shall be responsible for the correction of any damage incurred as a result of the performance of the contract.
  - 2. The roofing contractor shall remove all debris from the job site in a timely and legally acceptable manner so as to not detract from the aesthetics or the functions of the building.
- C. Security:

Obey the owner's requirements for personnel identification, inspection and other security measures which includes background checks for all onsite construction employees. Access to the roof will be via the exterior only.

## 1.10 JOB SITE PROTECTION

- A. The roofing contractor shall adequately protect building, paved areas, service drives, lawn, shrubs, trees, etc. from damage while performing the required work. Provide canvas, boards and sheet metal (properly secured) as necessary for protection and remove protection material at completion. The contractor shall repair or be responsible for costs to repair all property damaged during the roofing application.
- B. During the roofing contractor's performance of the work, the building owner will continue to occupy the existing building. The contractor shall take precautions to prevent the spread of dust and debris, particularly where such material may sift into the building. The roofing contractor shall provide labor and materials to construct, maintain and remove necessary temporary enclosures to prevent dust or debris in the construction area(s) from entering the remainder of the building.
- C. Do not overload any portion of the building, either by use of or placement of equipment, storage of debris, or storage of materials.
- D. Protect against fire and flame spread. Maintain proper and adequate fire extinguishers.
- E. Take precautions to prevent drains from clogging during the roofing application. Remove debris at the completion of each day's work and clean drains, if required. At completion, test drains to ensure the system is free running and drains are watertight. Remove strainers and plug drains in areas **where work is in progress**. Install flags or other telltales on plugs. Remove plugs each night and screen drain.

- F. Store moisture susceptible materials above ground and protect with waterproof coverings.
- G. Remove all traces of piled bulk materials and return the job site to its original condition upon completion of the work.

### **1.11 SAFETY**

The roofing contractor shall be responsible for all means and methods as they relate to safety and shall comply with all applicable local, state and federal requirements that are safety related. **Safety shall be the responsibility of the roofing contractor.** All related personnel shall be instructed daily to be mindful of the full time requirement to maintain a safe environment for the facility's occupants including staff, visitors, customers and the occurrence of the general public on or near the site.

### **1.12 WORKMANSHIP**

- A. Applicators installing new roof, flashing and related work shall be factory trained and approved by the manufacturer they are representing.
- B. All work shall be of highest quality and in strict accordance with the manufacturer's published specifications and to the building owner's satisfaction.
- C. There shall be a supervisor on the job site at all times while work is in progress.

### **1.13 QUALITY ASSURANCE**

- A. The manufacturer must have a minimum of 20 years experience in the manufacturing of vulcanized thermal set sheeting.
- B. Unless otherwise noted in this specification, the roofing contractor must strictly comply with the manufacturer's current specifications and details.
- C. The roofing system must be installed by an applicator authorized and trained by the manufacturer in compliance with shop drawings as approved by the manufacturer. The roofing applicator shall be thoroughly experienced and upon request be able to provide evidence of having at least five (5) years successful experience installing single-ply EPDM roofing systems and having installed at least 2 roofing application or several similar systems of equal or greater size within one year.
- D. Provide adequate number of experienced workmen regularly engaged in this type of work who are skilled in the application techniques of the materials specified. Provide at least one thoroughly trained and experienced superintendent on the job at all times roofing work is in progress.
- E. There shall be no deviations made from this specification or the approved shop drawings without the prior written approval of the specifier. Any deviation from the manufacturer's installation procedures must be supported by a written certification on the manufacturer's letterhead and presented for the specifier's consideration.
- F. Upon completion of the installation, the applicator shall arrange for an inspection to be made by a non-sales technical representative of the membrane manufacturer in order to determine whether or not corrective work will be required before the warranty will be issued. Notify the building owner seventy-two (72) hours prior to the manufacturer's final inspection.

### **1.14 JOB CONDITIONS, CAUTIONS AND WARNINGS**

Refer to Viking Products Group, Inc. Design "A" Fully Adhered Roofing System specification, Part II - Application, for General Job Site Considerations.

- A. Safety Data Sheets (SDS) must be on location at all times during the transportation, storage and application of materials.

- B. When positioning membrane sheets, exercise care to locate all field splices away from low spots and out of drain sumps. All field splices should be shingled to prevent bucking of water.
- C. When loading materials onto the roof, the Authorized Roofing Applicator must comply with the requirements of the building owner to prevent overloading and possible disturbance to the building structure.
- D. Proceed with roofing work only when weather conditions are in compliance with the manufacturer's recommended limitations, and when conditions will permit the work to proceed in accordance with the manufacturer's requirements and recommendations.
- E. Proceed with work so new roofing materials are not subject to construction traffic. When necessary, new roof sections shall be protected and inspected upon completion for possible damage.
- F. Provide protection, such as 3/4 inch thick plywood, for all roof areas exposed to traffic during construction. Plywood must be smooth and free of fasteners and splinters.
- G. The surface on which the insulation or roofing membrane is to be applied shall be clean, smooth, dry, and free of projections or contaminants that would prevent proper application of or be incompatible with the new installation, such as fins, sharp edges, foreign materials, oil and grease.
- H. New roofing shall be complete and weathertight at the end of the work day.
- I. Contaminants such as grease, fats and oils shall not be allowed to come in direct contact with the roofing membrane.

## 1.15 WARRANTY

- A. Provide manufacturer's (15 year) Membrane System Warranty covering both labor and material. The maximum wind speed coverage shall be peak gusts of 55 mph measured at 10 meters above ground level.
- B. Pro-rated System Warranties shall not be accepted.
- C. Evidence of the manufacturer's warranty reserve shall be included as part of the project submittals for the specifier's approval.

## PART 2 PRODUCTS

### 2.01 GENERAL

- A. All components of the specified roofing system shall be products of Viking Products Goup, Inc. or accepted by General Contractor as compatible.
- B. Unless otherwise approved by the specifier and accepted by the membrane manufacturer, all products (including insulation, fasteners, fastening plates and edgings) must be **manufactured and supplied** by the roofing system manufacturer and covered by the warranty.

### 2.02 MEMBRANE

Furnish EPDM (Ethylene, Propylene, Diene Terpolymer) in the largest sheet possible. The membrane shall conform to the minimum physical properties of ASTM D4637. When a 10 foot wide membrane is to be used, the membrane shall be manufactured in a single panel with no factory splices to reduce splice intersections.

### 2.03 INSULATION/UNDERLAYMENT

- A. When applicable, insulation shall be installed in multiple layers. The first and second layer of insulation shall



be mechanically fastened or adhered to the substrate in accordance with the manufacturer's published specifications.

- B. Insulation shall be approved PolyISO. Minimum R-value required is going to match existing

## 2.04 ADHESIVES AND CLEANERS

All products shall be furnished by Viking Products Group, Inc. and specifically formulated for the intended purpose.

- A. Bonding Adhesive: (Neoprene Bonding)
- B. Splicing Cement: Buytl Splicing Cement
- C. Splice Tape and Primer: Splice Tape and Primer Splice Wash.
- D. Cleaning Solvent: Splice Cleaner or Weathered Membrane Cleaner.
- E. External seam sealant: Pliobond Lap Sealant
- F. Sealer: Pliobond Pourable Sealer
- G. Insulation adhesive: DeckGrabber E HR Insulation Adhesive

## 2.05 FASTENERS AND PLATES

To be used for mechanical attachment of insulation and to provide additional membrane securement:

- A. **Fasteners:** A threaded, black epoxy electro-deposition coated fastener used with steel and wood roof decks.
- B. **Insulation Fastening Plates:** A 3 inch diameter FM approved metal plate used for insulation attachment.
- C. **Seam Fastening Plates:** A 2 inch diameter FM approved metal plate used in conjunction with RUSS or with EPDM membrane for membrane securement.
- D. **SA Perimeter Strip:** A 6 inch wide, 100 foot long strip of RubberTite reinforced EPDM membrane. The **6 inch wide Perimeter Strip** shall be utilized horizontally or vertically (in conjunction with Seam Fastening Plates) below the EPDM membrane for additional membrane securement.

## 2.06 METAL EDGING AND MEMBRANE TERMINATIONS

**Termination Bar:** a 1 inch wide and .098 inch thick extruded aluminum bar pre-punched 6 inches on center; incorporates a sealant ledge to support Lap Sealant and provide increased stability for membrane terminations.

## 2.08 OTHER MATERIALS

Metal Counterflashing

## PART 3 EXECUTION

### 3.01 GENERAL

- A. Comply with the manufacturer's published instructions for the installation of the membrane roofing system including proper substrate preparation, jobsite considerations and weather restrictions.

- B. Position sheets to accommodate contours of the roof deck and shingle splices to avoid bucking water.

### **3.02 INSULATION PLACEMENT (if needed)**

- A. Install insulation or membrane underlayment over the substrate with boards butted tightly together with no joints or gaps greater than 1/4 inch. Stagger joints both horizontally and vertically if multiple layers are provided.
- B. Secure insulation to the substrate with the required mechanical fasteners or Insulation Adhesive in accordance with the manufacturer's specifications.

### **3.03 MEMBRANE PLACEMENT AND BONDING**

- A. Unroll and position membrane without stretching. Allow the membrane to relax for approximately 1/2 hour before bonding. Fold the sheet back onto itself so half the underside of the membrane is exposed.
- B. Apply the Bonding Adhesive in accordance with the manufacturer's published instructions, to both the underside of the membrane and the substrate. Allow the adhesive to dry until it is tacky but will not string or stick to a dry finger touch.
  - 1. Roll the coated membrane into the coated substrate while avoiding wrinkles. Brush down the bonded half of the membrane sheet with a soft bristle push broom to achieve maximum contact.
  - 2. Fold back the unbonded half of the membrane sheet and repeat the bonding procedure.
- C. Install adjoining membrane sheets in the same manner, overlapping edges approximately 4 inches. Do not apply bonding adhesive to the splice area.

### **3.04 MEMBRANE SPLICING (Adhesive Splice)**

- A. Fold the top sheet back and clean the dry splice area (minimum 3 inches wide) of both membrane sheets by scrubbing with clean natural fiber rags saturated with Splice Cleaner or Primer/Splice Wash.
- B. Apply Splice Adhesive in accordance with the manufacturer's specifications and roll the top sheet onto the mating surface.
- C. Roll the splice with a 2 inch wide steel roller and wait at least 2 hours before applying Lap Sealant to the splice edge following the manufacturer's requirements.

### **3.05 MEMBRANE SPLICING (Tape Splice)**

- A. Overlap adjacent sheets and mark a line 1/2 inch out from the top sheet.
- B. Fold the top sheet back and clean the dry splice area (minimum 2-1/2 inches wide) of both membrane sheets with Sure-Seal Primer as required by the membrane manufacturer.
- C. Where Splice Tape to bottom sheet with the edge of the release film along the marked line. Press tape onto the sheet using hand pressure. Overlap tape roll ends a minimum of 1 inch.
- D. Remove the release film and press the top sheet onto the tape using hand pressure.
- E. Roll the seam toward the splice edge with a 2 inch wide steel roller.
- F. Install a 6 inch wide section of Pressure-Sensitive Flashing over all field splice intersections and seal edges of flashing with Lap Sealant.
- G. The use of Lap Sealant with tape splices is optional except at tape overlaps and cut edges of reinforced membrane where Lap Sealant is required.

### **3.06 FLASHING**

- A. Wall and curb flashing shall be cured EPDM membrane. Continue the deck membrane as wall flashing where practicable.
- B. Follow manufacturer's typical flashing procedures for all wall, curb, and penetration flashing including metal edging/coping and roof drain applications.

### **3.08 DAILY SEAL**

- A. On phased roofing, when the completion of flashings and terminations is not achieved by the end of the work day, a daily seal must be performed to temporarily close the membrane to prevent water infiltration.
- B. Use Pliobond Pourable Sealer or other acceptable membrane seal in accordance with the manufacturer's requirements.

### **3.09 CLEAN UP**

- A. Perform daily clean-up to collect all wrappings, empty containers, paper, and other debris from the project site. Upon completion, all debris must be disposed of in a legally acceptable manner.
- B. Prior to the manufacturer's inspection for warranty, the applicator must perform a pre-inspection to review all work and to verify all flashing has been completed as well as the application of all caulking.

**END OF SPECIFICATION**

## 6. Scope of Work, Details, & Drawings

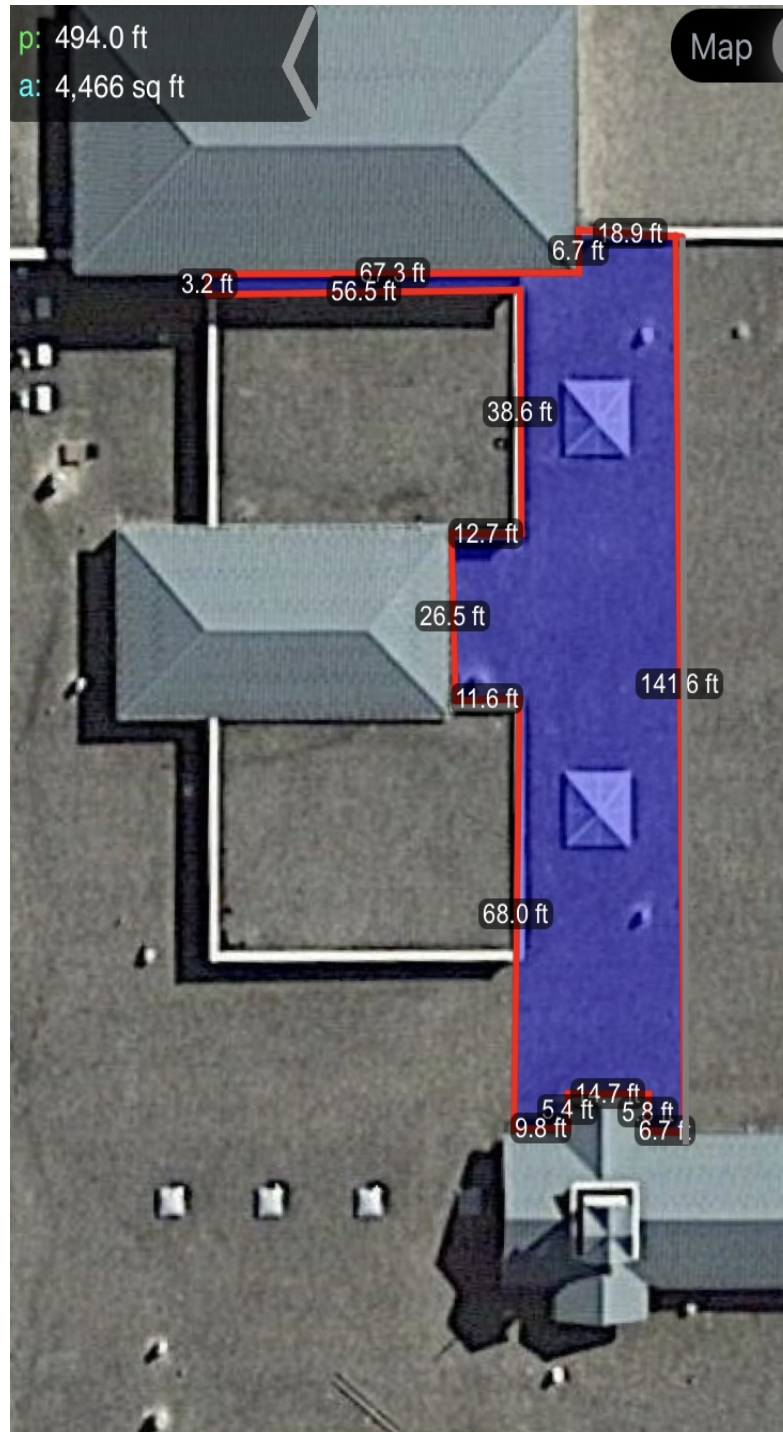

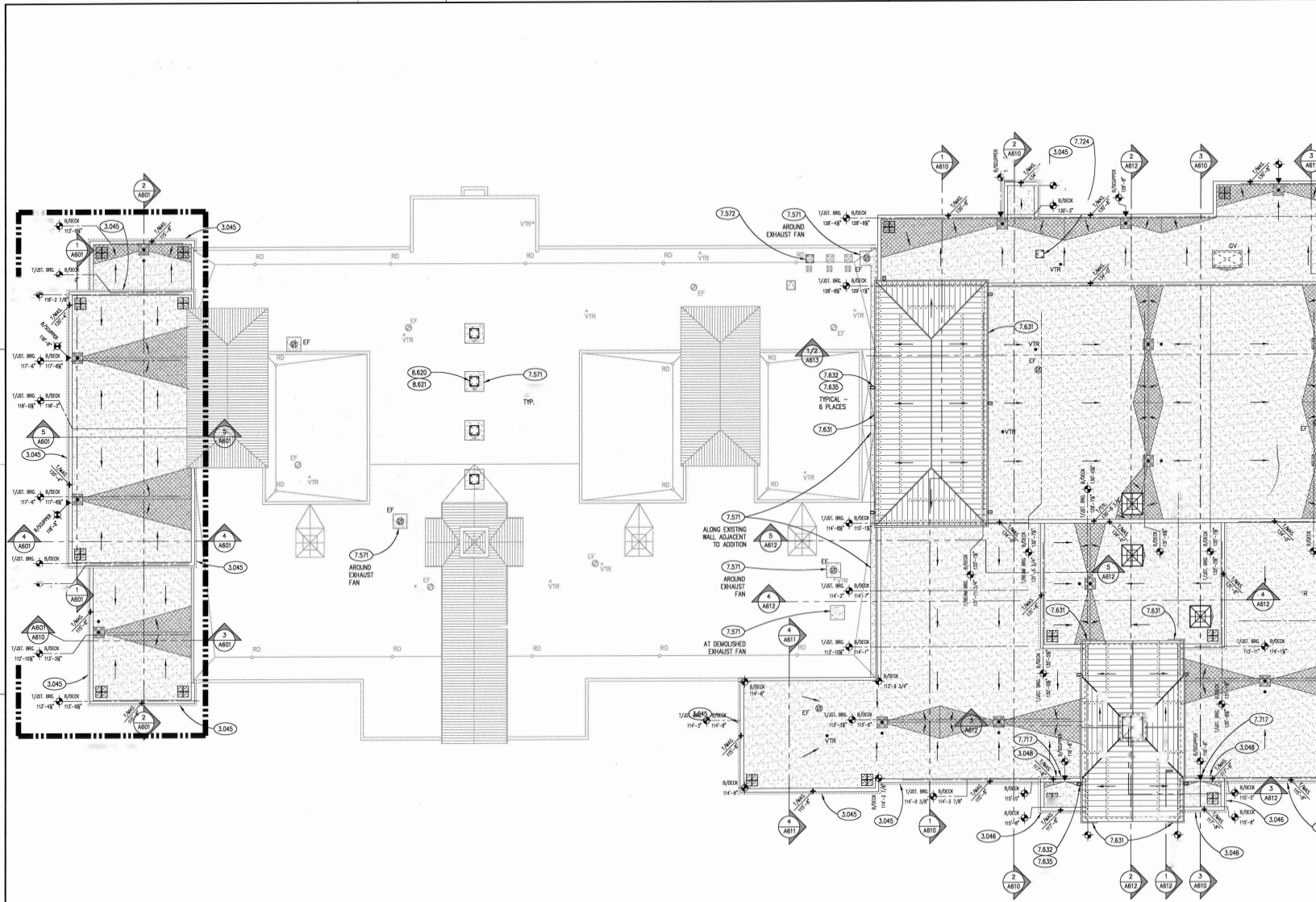

## KEYNOTES

- 7.411 PREFORMED METAL ROOF PANELS.
- 7.550 SINGLE-PLY, BALLASTED ROOFING SYSTEM.
- 7.556 SINGLE-PLY ROOFING MATERIAL: RIGID INSULATION; TAPERED.
- 7.562 SINGLE-PLY ROOFING ACCESSORY: CONCRETE WALKWAY PAVER.
- 7.571 PATCH EXISTING ROOFING.
- 7.572 NEW ROOF PENETRATION THROUGH EXISTING ROOF CURB; PROVIDE NEW COUNTERFLASHING AS REQUIRED PER NRCA STANDARD DETAILS.
- 7.631 METAL GUTTER: MATERIAL, THICKNESS AND FINISH AS SPECIFIED.
- 7.632 METAL DOWNSPOUT: MATERIAL, THICKNESS AND FINISH AS SPECIFIED.
- 7.635 METAL DOWNSPOUT ACCESSORY: PRECAST CONCRETE SPLASH PAD.
- 7.715 OVERFLOW SCUPPER: 8"W X 4"H; CONSTRUCT IN ACCORDANCE WITH ARCHITECTURAL SHEET METAL MANUAL FIGURE 1-30.
- 7.717 SCUPPER THROUGH WALL: 8"W X 8"H; CONSTRUCT IN ACCORDANCE WITH WITH ARCHITECTURAL SHEET METAL
- 8.620 DOMED UNIT SKYLIGHT: SIZE AS INDICATED.
- 8.621 DOMED UNIT SKYLIGHT ACCESSORY: INSULATED ROOF CURB. 8.630 METAL-FRAMED SKYLIGHT.
- 15.012 ROOF DRAIN ASSEMBLY

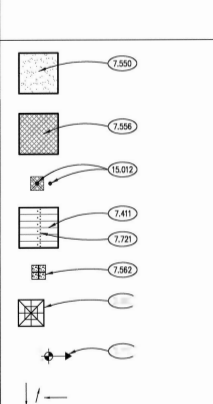

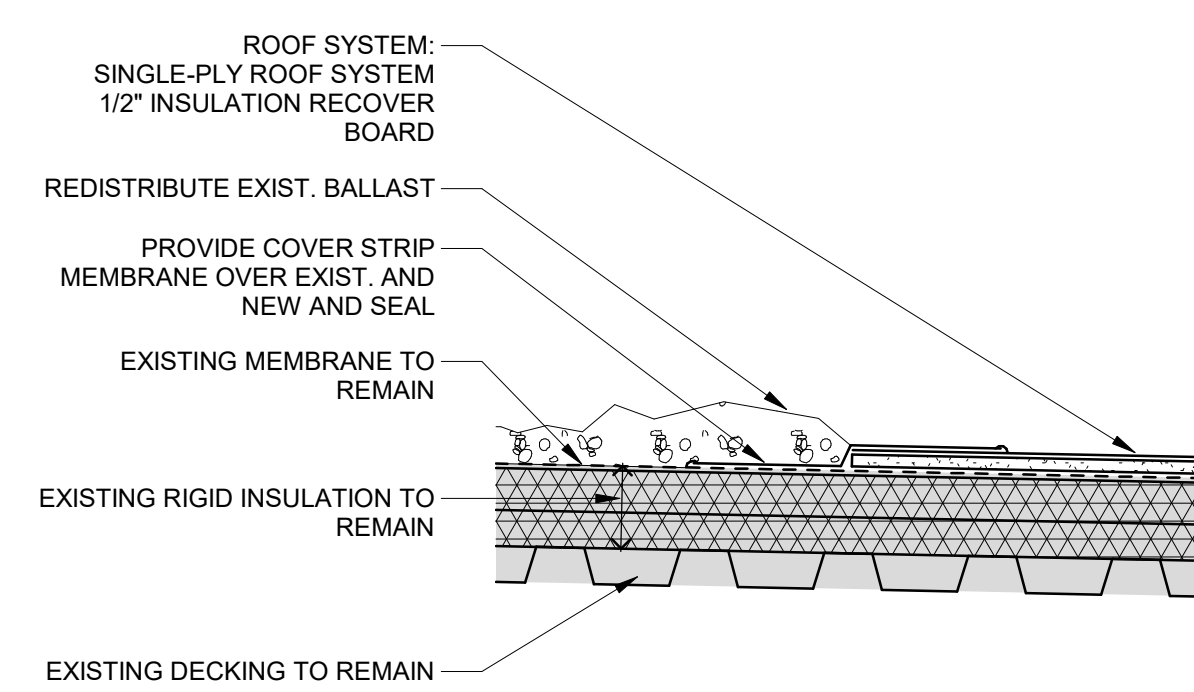

**E1 TRANSITION DETAIL**  
1 1/2" = 1'-0"  
0 1/2 1'

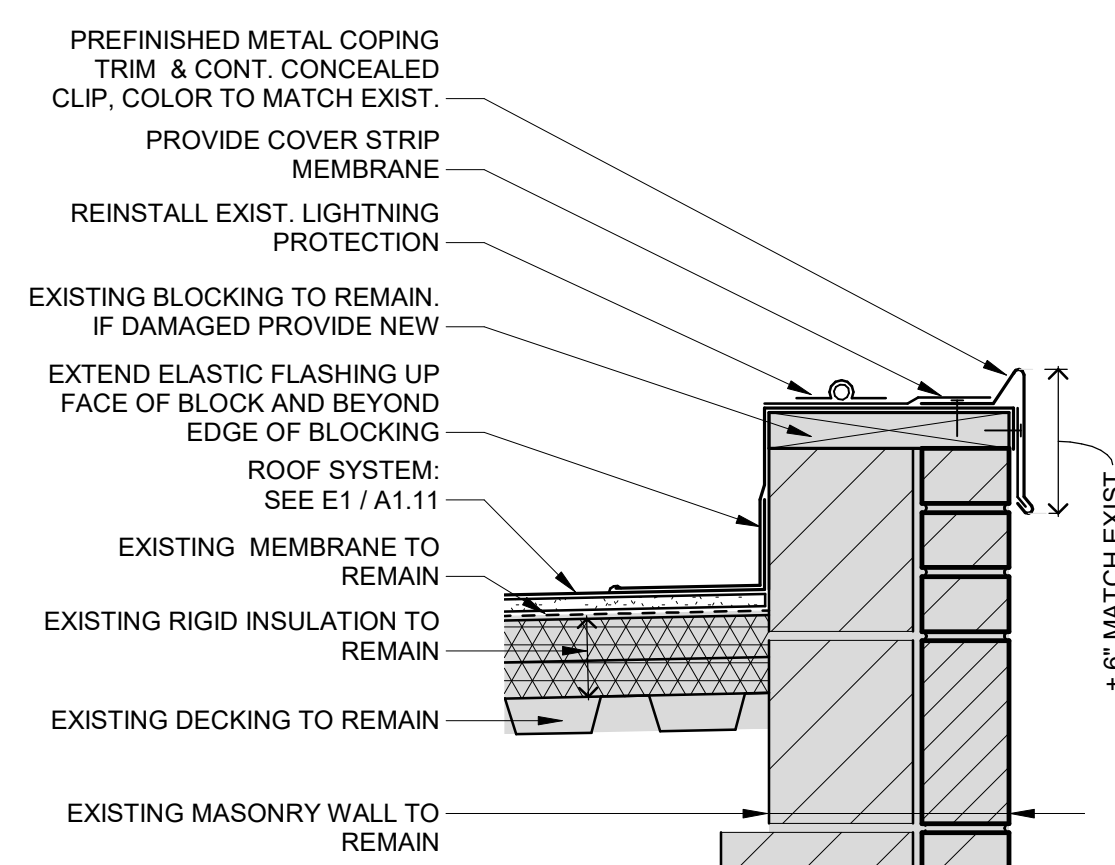

**E2 COPING DETAIL**  
1 1/2" = 1'-0"  
0 1/2 1'

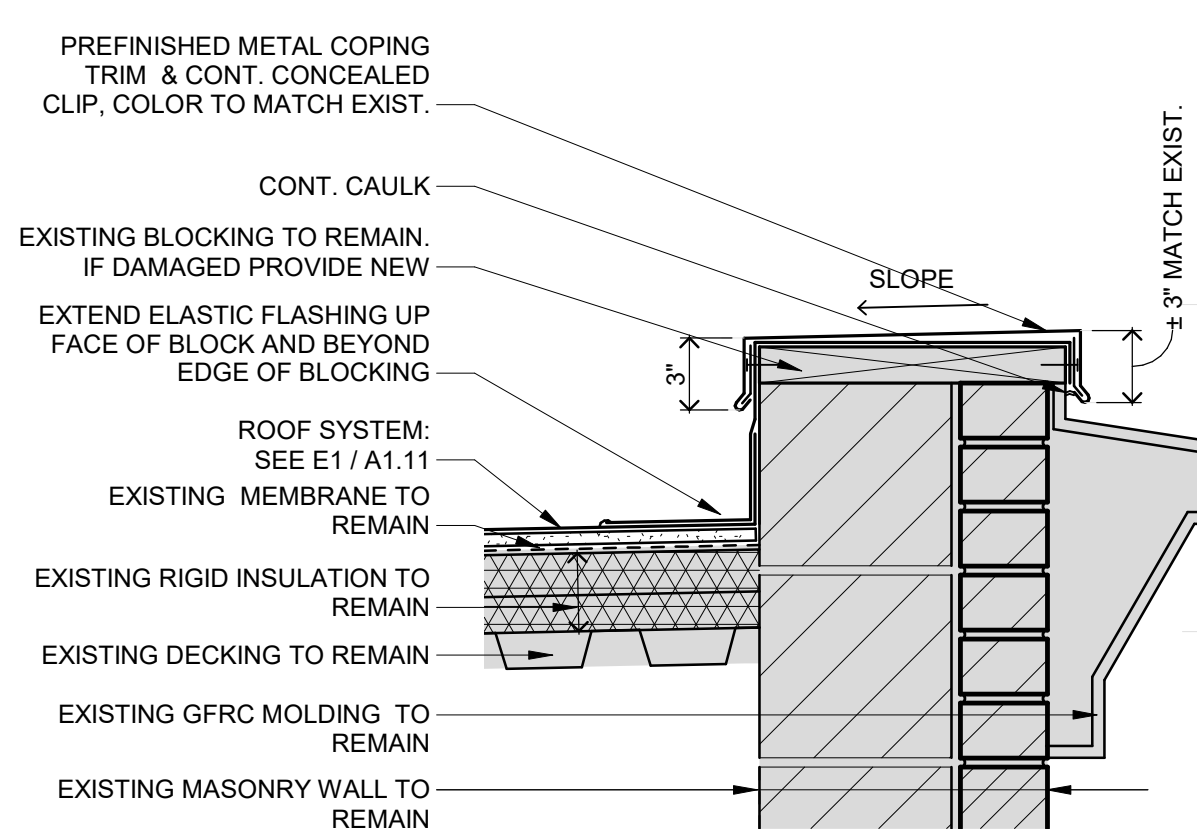

**E4 COPING DETAIL**  
1 1/2" = 1'-0"  
0 1/2 1'

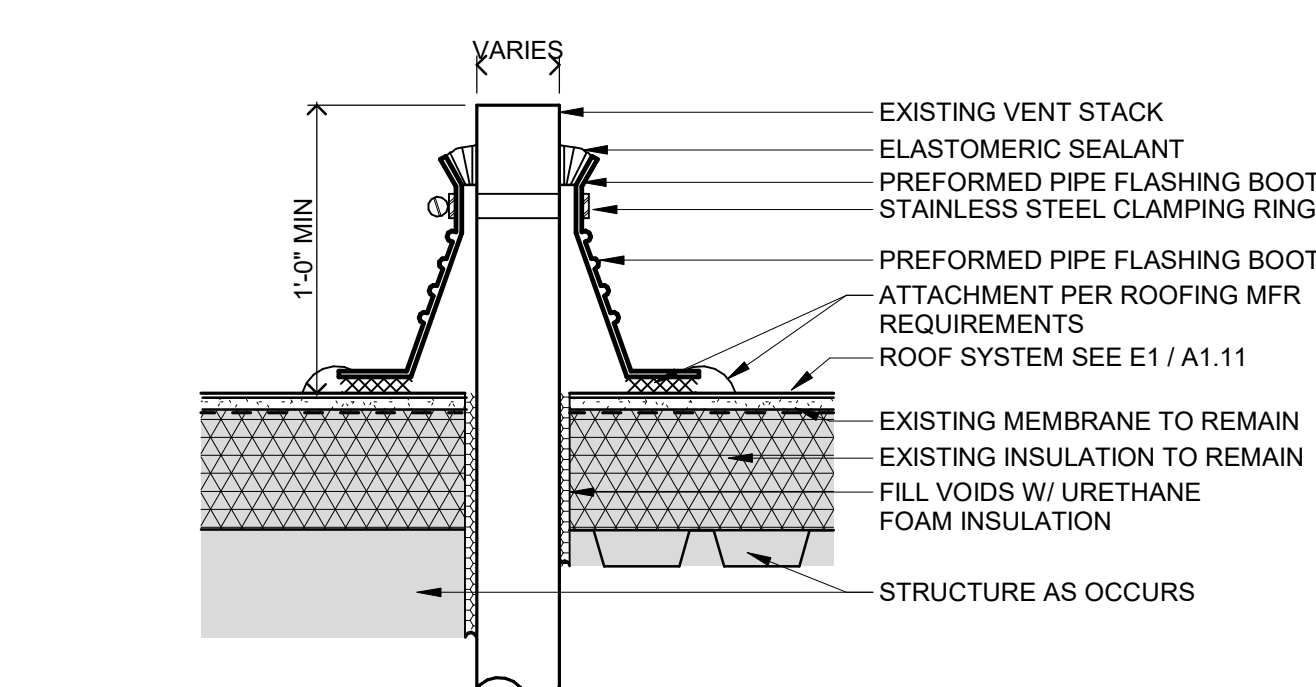

**C5 ROOF VENT**  
1 1/2" = 1'-0"  
0 1/2 1'

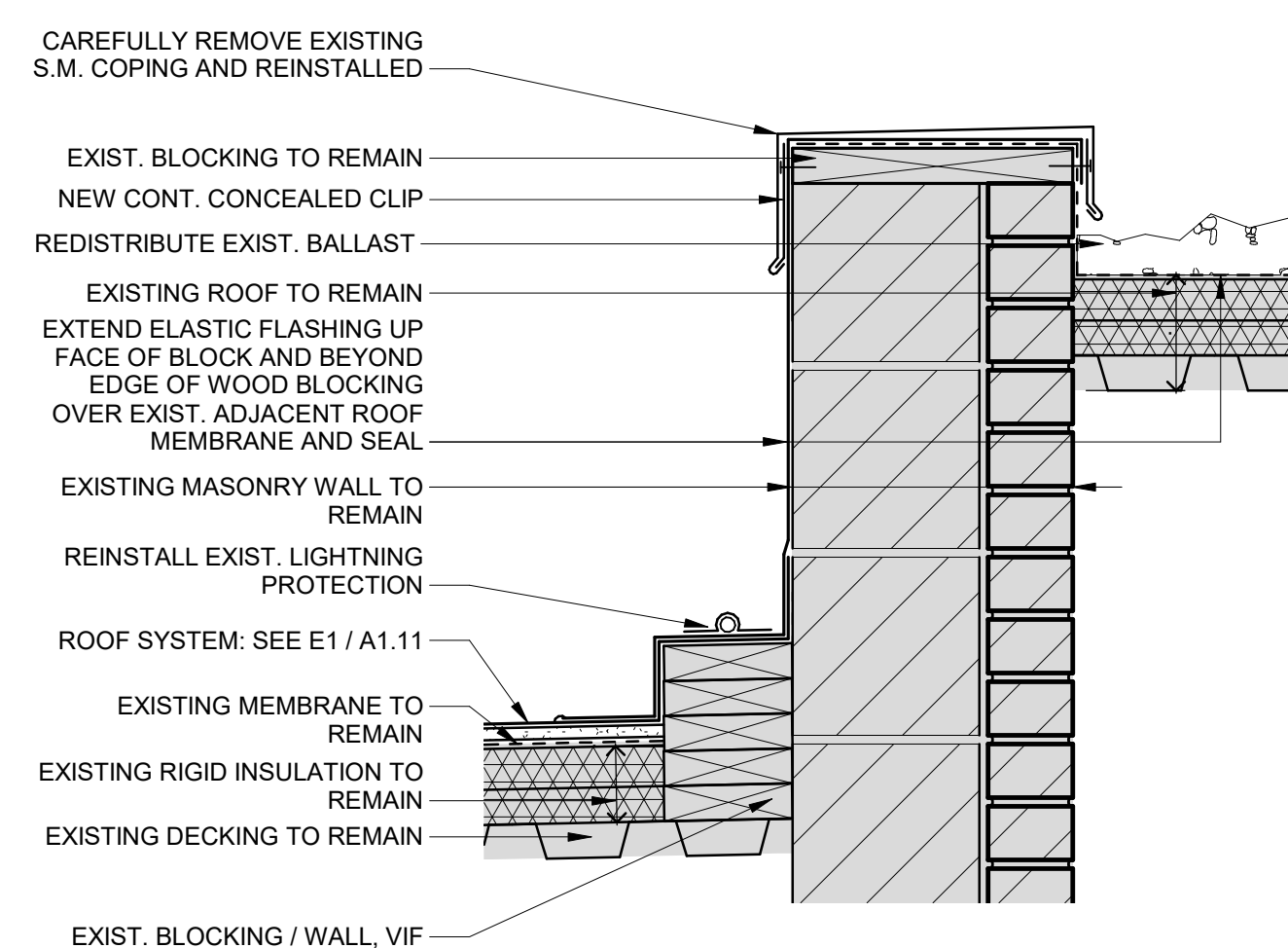

**F4 COPING DETAIL**  
1 1/2" = 1'-0"  
0 1/2 1'

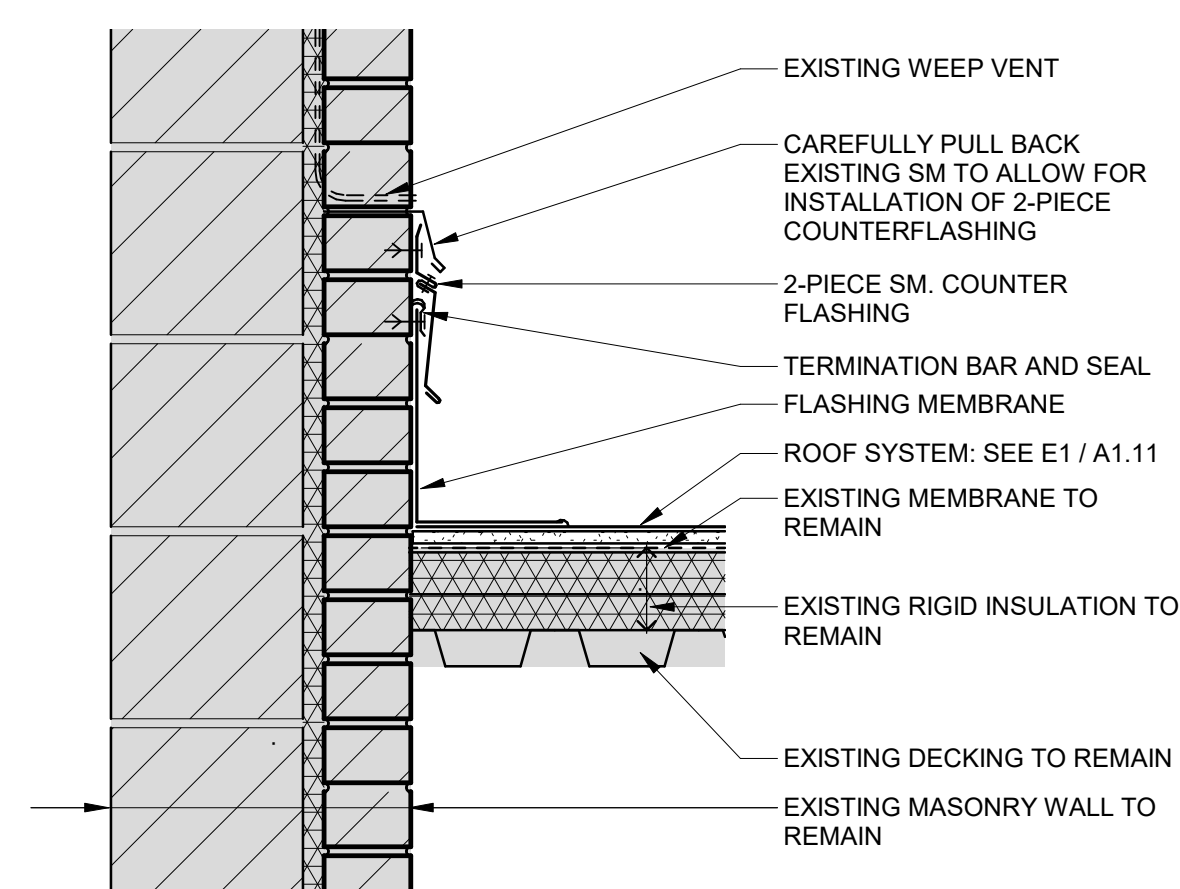

**F5 WALL TERMINATION DETAIL**  
1 1/2" = 1'-0"  
0 1/2 1'

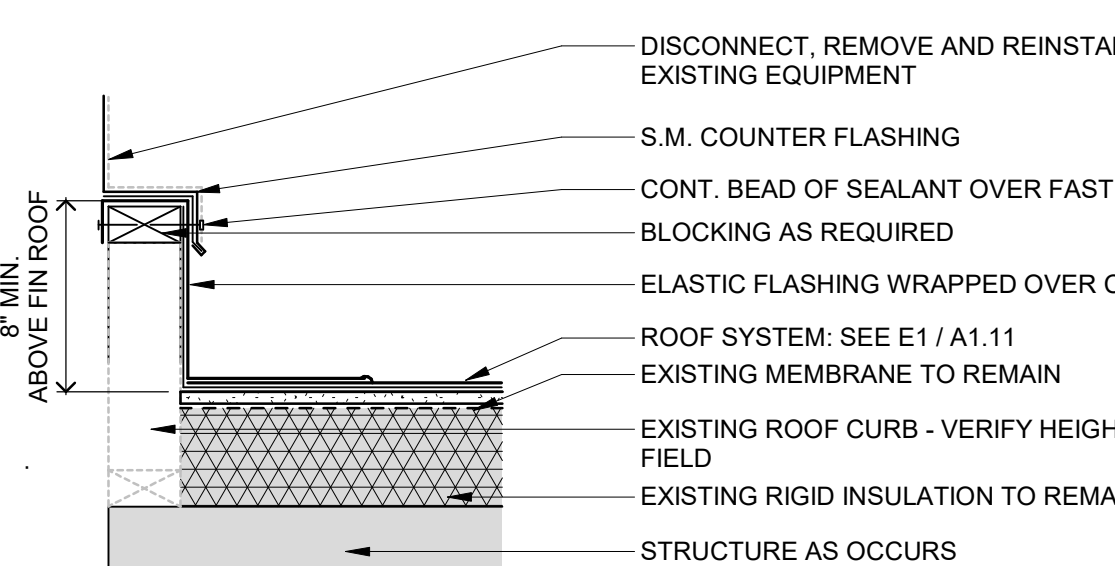

**E5 CURB DETAIL**  
1 1/2" = 1'-0"  
0 1/2 1'

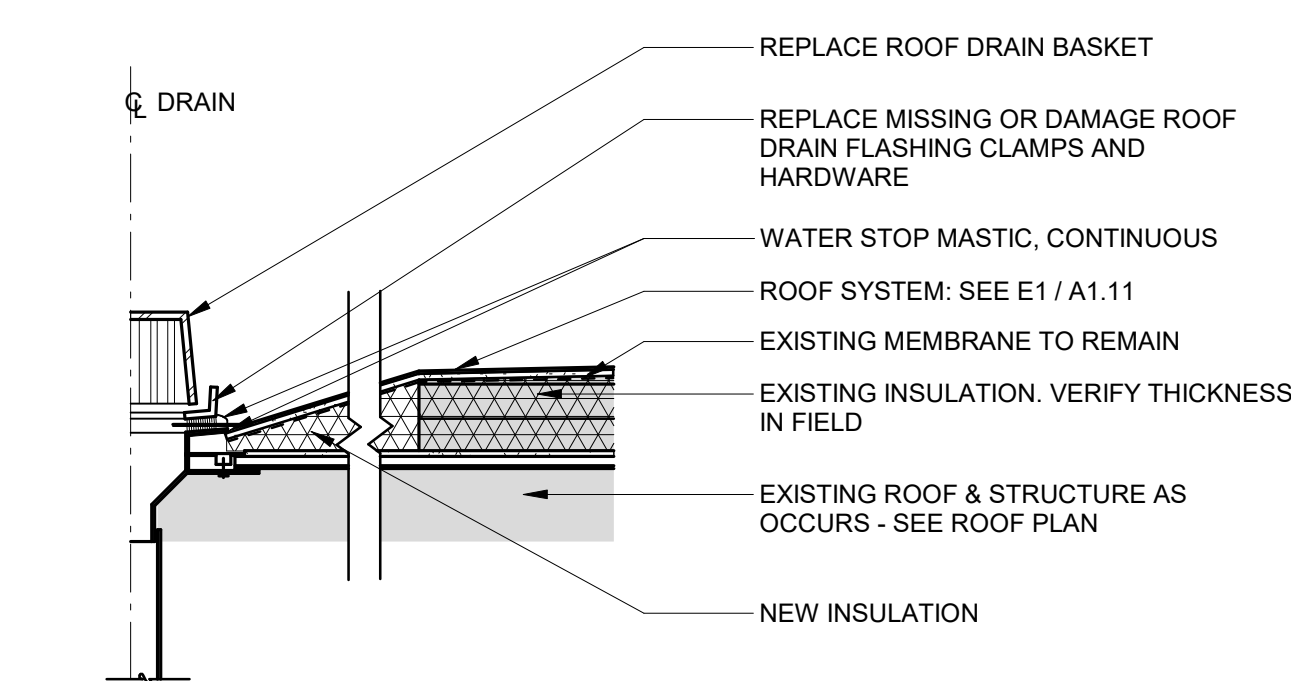

**B5 ROOF DRAIN SUMP SECTION**  
3/4" = 1'-0"  
0 1 2'

**ROOF LEGEND**

- ☒ RD ROOF DRAIN
- ☒ ROOF EXHAUST
- PV.X VENT STACK, PIPE OR CONDUIT
- ☒ EXISTING SKYLIGHT
- ▽ CRICKET FOR POSITIVE DRAINAGE
- SLOPE OF TAPERED INSULATION, VERIFY IN THE FIELD
- SLOPED STRUCTURE
- ☒ BASE BID: NEW ROOF SYSTEM (APPROX. ± 6000 SQ. FT.)
- ☒ ALTERNATE 1: NEW ROOF SYSTEM (APPROX. ± 500 SQ. FT.)
- NIC NOT IN CONTRACT

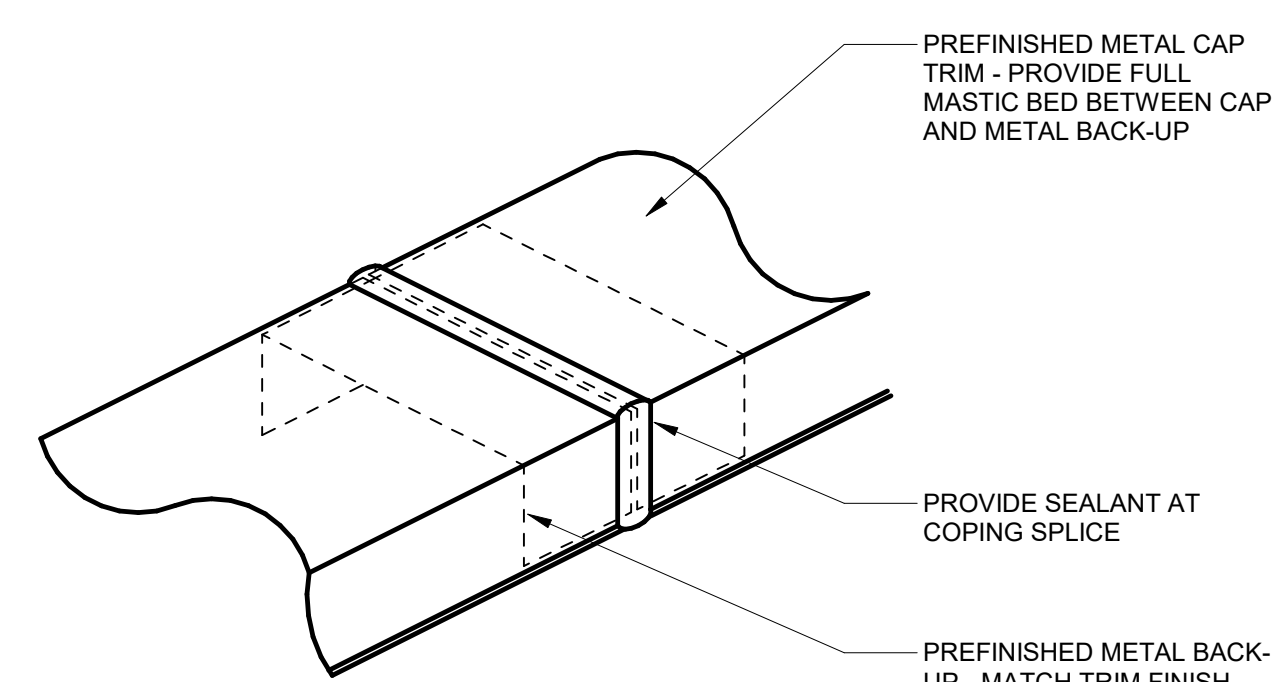

**F2 COPING DETAIL - NTS**  
NOT TO SCALE

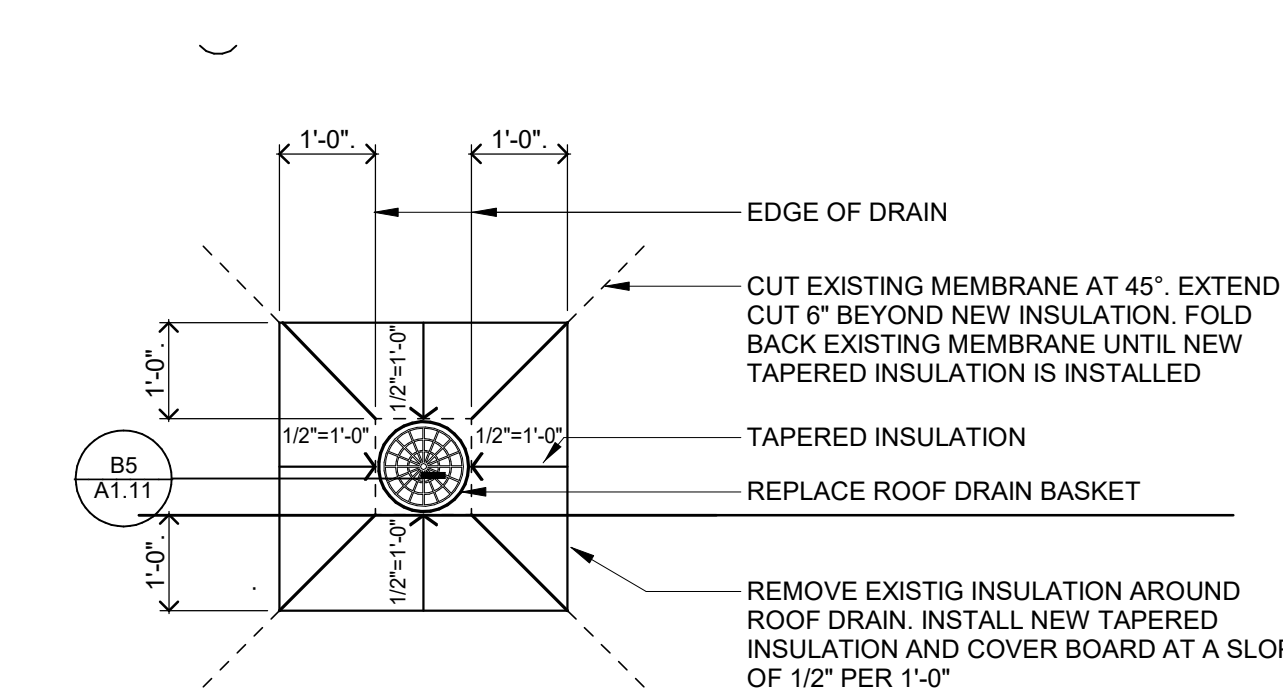

**A5 ROOF DRAIN TYPICAL SUMP PUMP**  
3/8" = 1'-0"  
0 2 4'

**ROOF PLAN KEY NOTES:**

- 1 EXISTING SHEET METAL COPING TO BE REMOVED AND REPLACED TO ALLOW FOR INSTALLATION OF NEW MEMBRANE. NEW TO MATCH EXISTING PROFILE.
- 2 CAREFULLY REMOVE EXISTING SHEET METAL COPING AND REINSTALLED TO ALLOW FOR INSTALLATION OF NEW MEMBRANE.
- 3 PROVIDE WALKWAY PAD AND SPLASHBLOCKS AT DOWNSPOUT DISCHARGE.
- 4 EXISTING ROOF DRAIN LOCATIONS - ADJUST HEIGHT / PROVIDE EXTENSION AS REQUIRED TO MATCH NEW INSULATION / RECOVER BOARD THICKNESS.
- 5 DISCONNECT, REMOVE AND REINSTALL AND RECONNECT EXIST. HVAC UNIT. RAISE CURB, SEE E5 / A1.11. PROVIDE METAL COUNTERFLASHINGS. CONTRACTOR RESPONSIBLE FOR EXTENSION OF DUCTWORK, GAS AND / OR ELECTRICAL, AS OCCURS.
- 6 REMOVE EXISTING LIGHTNING PROTECTION AND REINSTALL. REMOVAL AND REINSTALLATION SHALL BE BY CERTIFIED LIGHTNING PROTECTION CONTRACTOR.
- 7 RUN MEMBRANE UP THE FACE OF WALL BELOW EXISTING GFRM MOLDING CAP AND SEAL.
- 8 PROVIDE PREFINISHED METAL END WALL FLASHING, COPING END AND CORNER EDGE PIECE AS REQUIRED. PROVIDE SEALANT FOR A COMPLETE WEATHERTIGHT SYSTEM.

**ROOF DEMOLITION GENERAL NOTES:**

1. ROOF DEMOLITION INCLUDES REMOVING EXISTING BALLAST, REMOVING EXISTING FLASHING / COUNTER FLASHING AT CURBS, WALLS, PIPE PENETRATIONS AND PARAPET INCLUDING SEALANTS, FASTENERS AND ASSOCIATED ACCESSORIES - SEE HATCHED AREAS AND DETAILS. EXISTING ROOFING MEMBRANE TO REMAIN IN PLACE OVER EXISTING INSULATION UNLESS NOTED OTHERWISE. CONTRACTOR TO DISABLE EXISTING MEMBRANE IN ONE OF THE FOLLOWING METHODS PER MANUFACTURER'S RECOMMENDATION: SLIT THE EXISTING MEMBRANE ON A 10'X10' GRID PATTERN OR CUT AND REMOVE 4" DIAMETER CORE IN EXISTING MEMBRANE EVERY 100 S.F. PRIOR TO INSTALLATION OF NEW COVER BOARD TO ALLOW ANY TRAPPED VAPOR TO BE RELEASED.
2. DEMOLITION NOTES ARE PROVIDED AS A GUIDE ONLY. CONTRACTOR TO VERIFY EXISTING CONDITIONS AND EXAMINE DRAWINGS AND DETAILS TO DETERMINE EXTENT AND LIMITS OF DEMOLITION REQUIRED TO ACCOMMODATE NEW CONSTRUCTION.
3. CONTRACTOR IS RESPONSIBLE FOR COORDINATION OF ALL ASPECTS OF DEMOLITION. CONTRACTOR TO REVIEW ALL DRAWINGS FOR ADDITIONAL DETAILS AND CONSTRUCTION SEQUENCING NOTES.
4. DEMOLITION CONTRACTOR SHALL CAREFULLY REMOVE CONSTRUCTION DESIGNATED FOR DEMOLITION TO MINIMIZE EXTENT OF DAMAGES TO ADJACENT SURFACE. CONTRACTOR IS RESPONSIBLE FOR REPAIR OF ALL DAMAGE CREATED DUE TO CONSTRUCTION.
5. CONTRACTOR IS RESPONSIBLE FOR CONTAINMENT AND CLEANING OF CONSTRUCTION DUST AND DEBRIS DURING AND AFTER ANY DEMOLITION OR INSTALLMENT OF WORK.
6. PROTECT EXISTING ROOFTOP MECHANICAL UNITS AND ASSOCIATED PIPING DURING ALL WORK.
7. SWEEP ALL ROOF SURFACES TO REMOVE ALL DEBRIS AND DIRT FOR SMOOTH ROOFING AREA PRIOR TO INSTALLATION OF SINGLE PLY ROOFING SYSTEM.

**ROOF PLAN GENERAL NOTES:**

1. NEW ROOF SYSTEM INCLUDES SINGLE PLY MEMBRANE ON 1/2" INSULATION RECOVER BOARD OVER EXISTING ROOF MEMBRANE. FASTEN 1/2" INSULATION RECOVER BOARD THRU EXISTING ROOFING SYSTEM TO THE EXISTING METAL DECK.
2. FIELD VERIFY ALL EXISTING CONDITIONS.
3. MECHANICAL ITEM LOCATIONS ARE SHOWN FOR REFERENCE ONLY. CONTRACTOR TO FIELD VERIFY EXACT LOCATIONS.
4. CONTRACTOR IS RESPONSIBLE FOR MAINTAINING AN INSULATED, WEATHERTIGHT ENCLOSURE FOR THE DURATION OF CONSTRUCTION.
5. CONTRACTOR RESPONSIBLE FOR REPAIRING ANY BUILDING AND SITE DAMAGE FROM CONSTRUCTION ACTIVITIES TO ORIGINAL CONDITION.
6. INSPECT EXISTING ROOF FOR ANY WET INSULATION AND RUSTED / UNSOUND METAL DECK. REPLACE WITH LIKE MATERIAL ON UNIT PRICE BASIS.
7. TEST ROOF DRAIN AFTER COMPLETION OF ROOF WORK.



---

PART 1 — GENERAL

1.1 WORK COVERED BY CONTRACT DOCUMENTS

- A. The following brief description is not intended to totally define the scope of work. Refer to the contract documents for an entire description of the project scope.
- B.1 The successful Proposer shall provide labor, Garland and non-Garland materials to install a restoration coating

The general scope of work is as follows: **Kendall County Courthouse Roof Recover**

**Garlands Viking EPDM Fully Adhered Roofing System**

1. Stage and mobilize equipment & material
2. Vac off existing ballasted river rock
3. Cut existing membrane into 10' strips and completely remove
4. (per Nuclear Scan) replace wet Insulation
5. Re-using existing Insulation- mechanically fasten existing insulation.
6. Install 1/2" Recovery board- dens deck and set in Garlands Insu-lock adhesive
7. Fully Adhere and install 60 mil NEW EPDM membrane in neoprene adhesive
- 8 . Install 3x3 drain sumps with new leed
9. Install all new flashings in neoprene adhesive
10. Install all new termination bar and surface mounted counter flashings
11. Apply Garlands Rust Go Primer and Paint for rust inhibiting paint for reglets
- 12 . 3-days prior to completion conduct on site walk thru with owners representative for punch out list.
13. Complete punch out list.
14. Full clean/ sweep of all construction debris.



C. Contractor's duties:

1. Except as otherwise specifically excluded, provide and pay for:
  - a. Labor, equipment and required safety equipment.
  - b. Tools, construction equipment and machinery.
  - c. Water, heat and utilities required for construction (if applicable).
  - d. Other facilities and services necessary for proper execution and completion of the work, including proper disposal of removed roofing and waste.
  - e. Products used for the completion of the project.

Pay legally required sales, consumer and use taxes (if applicable).
3. Pay Prevailing wage rates in compliance with Kendall County rates, and provide certified payroll documentation to the Owner upon request.





INFRARED | ROOFING | TECHNOLOGIES  
"Revealing the Hidden Truth"

Roof Diagnostic Survey For:

## Kendall County Courthouse

807 John St.

Yorkville, IL 60560

Understanding Building Roof Infrared Imagery & Nuclear Surveys

Nuclear Readings: 1-8 = Dry, 9 & Above = Wet

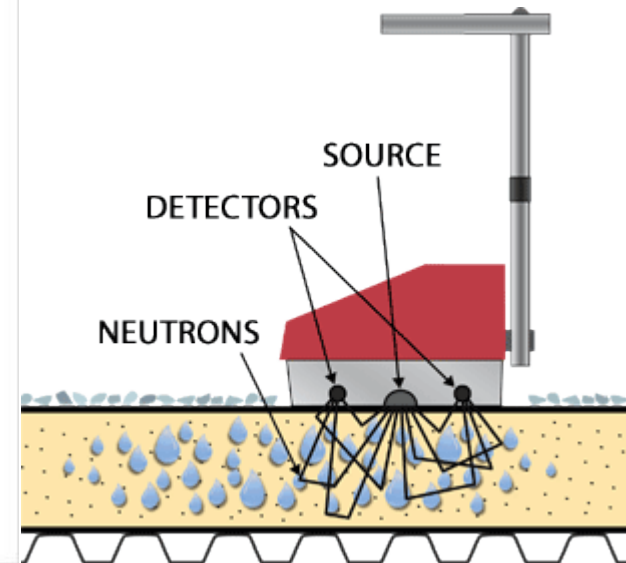
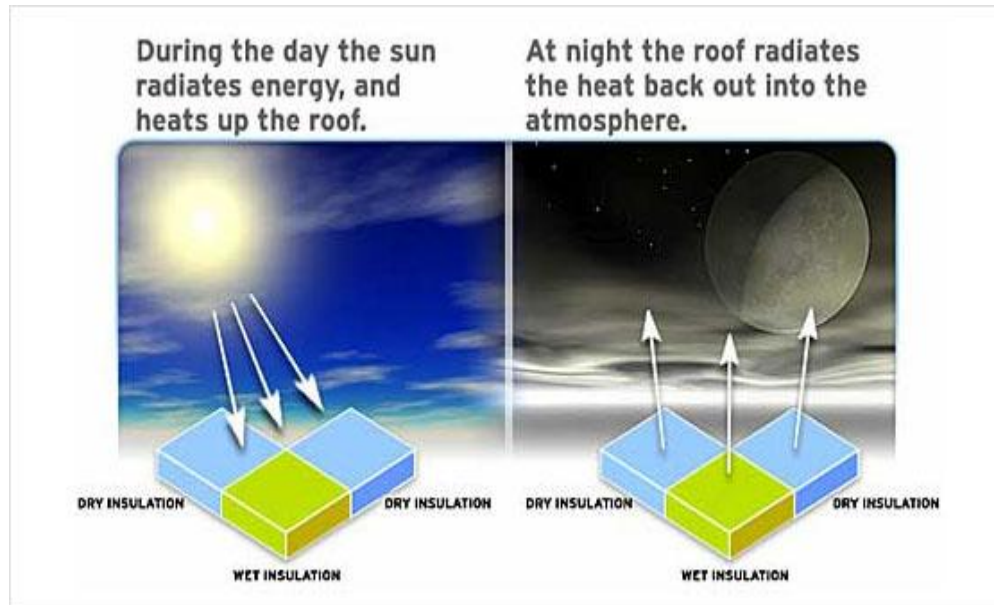

2149 Potter Rd. E.  
Traverse City, MI 49696  
231.590.9899  
www.irtroofing.com



**INFRARED | ROOFING | TECHNOLOGIES**  
“Revealing the Hidden Truth”

### **Understanding Nuclear Surveys**

A nuclear roof moisture survey is the only effective method for locating areas of wet insulation within a ballasted roof system or multi-layered roof assembly. A nuclear gauge is used to detect varying levels of hydrogen ions within the roof system, with hydrogen being most abundant in wet materials. Readings are taken in conjunction with physical sampling to determine a baseline reading for dry materials. Typically readings are taken on a 10'x10' grid pattern and transferred to a scaled roof plan showing a visual representation of the wet areas. Readings over the dry baseline benchmark indicate damp to wet materials, with moisture content increasing with higher readings.

**Inspector: Len Simkins**

**Phone: (231) 590-9899**

**This report provides the inspector’s opinion of the condition of the elements inspected. The findings are based on a limited time/scope inspection performed according to the terms of Infrared Roofing Technologies and in a manner consistent with property inspection industry standards. The inspection is limited to readily accessible systems or components of the property. No guarantees are implied with respect to future deficiencies or conditions. No engineering, geological, design, environmental, biological, health related or code compliance evaluations of the property were performed. The information in this report was prepared exclusively for the named client and/or their authorized representative. The report, including supplemental information and addenda should be reviewed in its entirety.**

**Comments: Overall the roof was dry which is detailed in the report. I would recommend regularly cleaning your drains and removing the debris off the roof itself. Thank you for allowing Infrared Roofing Technologies to perform a Nuclear inspection of your facility. If you have any questions please do not hesitate to call or e-mail me.**

**Thanks again – Len Simkins**

**RSO & Level 2 Thermographer**

2149 Potter Rd. E.  
Traverse City, MI 49696  
231.590.9899  
[www.irtroofing.com](http://www.irtroofing.com)



INFRARED | ROOFING | TECHNOLOGIES  
"Revealing the Hidden Truth"

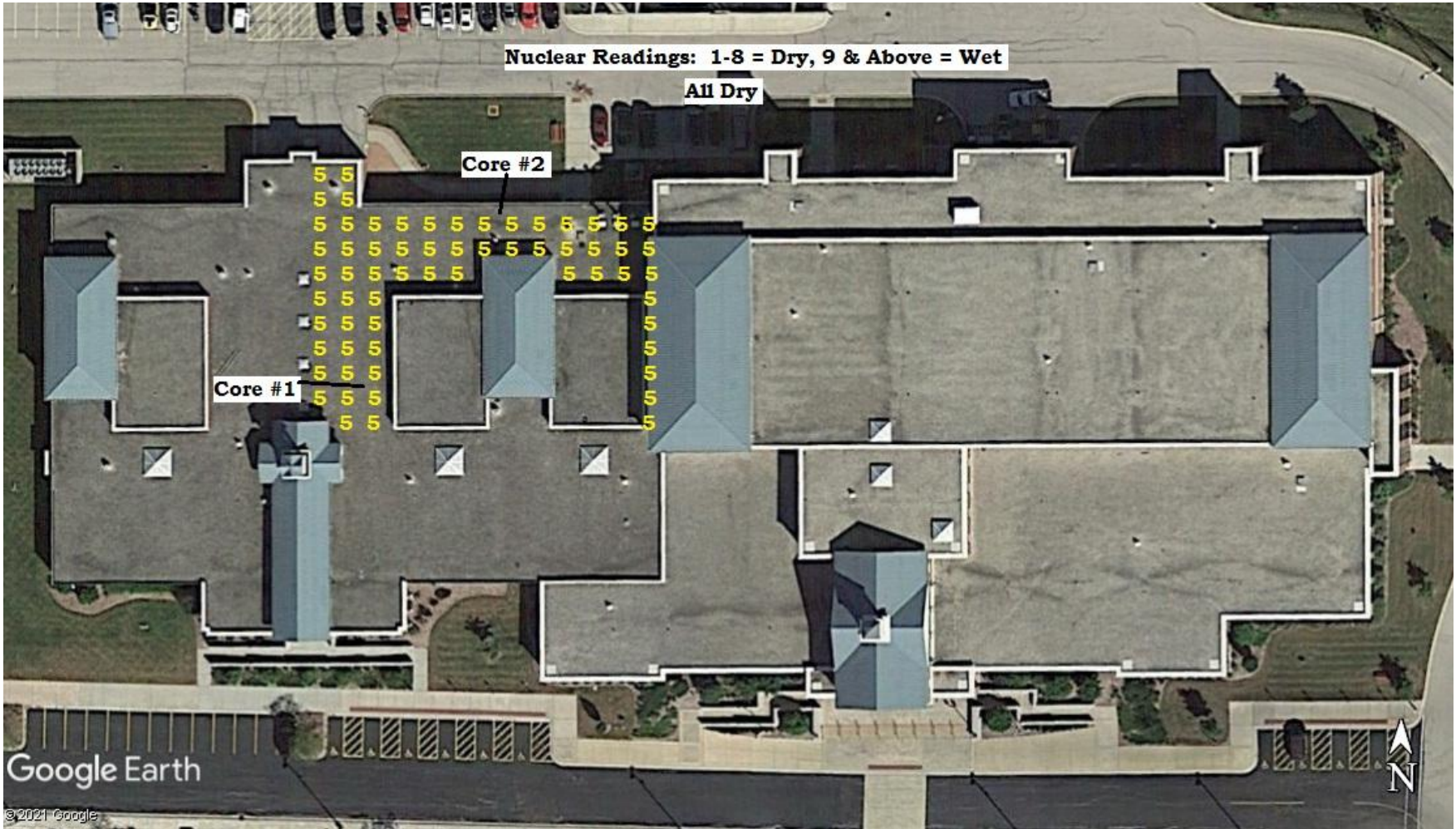

2149 Potter Rd. E.  
Traverse City, MI 49696  
231.590.9899  
[www.irtroofing.com](http://www.irtroofing.com)

# IRT

INFRARED | ROOFING | TECHNOLOGIES  
"Revealing the Hidden Truth"

## Overview Photos



2149 Potter Rd. E.  
Traverse City, MI 49696  
231.590.9899  
[www.irtroofing.com](http://www.irtroofing.com)

# IRT

INFRARED | ROOFING | TECHNOLOGIES  
"Revealing the Hidden Truth"

## Overview Photos



2149 Potter Rd. E.  
Traverse City, MI 49696  
231.590.9899  
[www.irtroofing.com](http://www.irtroofing.com)



INFRARED | ROOFING | TECHNOLOGIES  
"Revealing the Hidden Truth"

Core Report

**Core #1** – Metal Deck, 3" ISO, Ballasted EPDM - Dry



**Core #2** – Metal Deck, 3" ISO, Ballasted EPDM - Dry



2149 Potter Rd. E.  
Traverse City, MI 49696  
231.590.9899  
[www.irtroofing.com](http://www.irtroofing.com)