

ENGINEERING DEPARTMENT

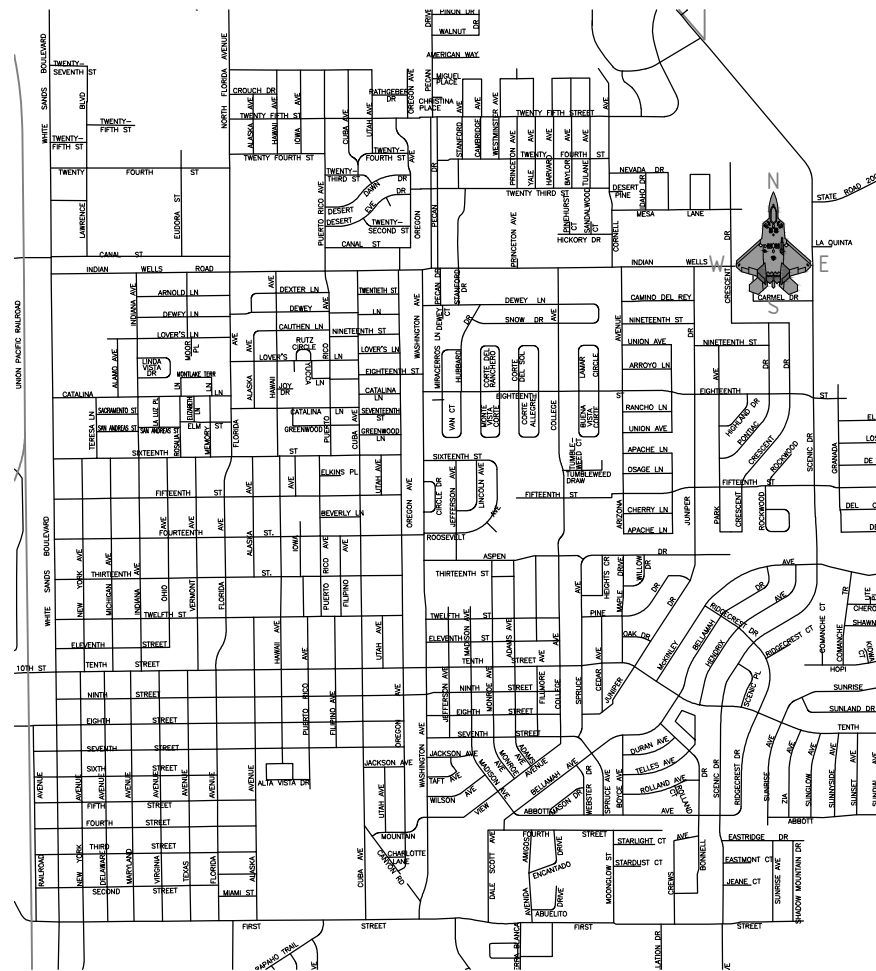

VICINITY MAP
NO SCALE



2019 IMPROVEMENT PLANS FOR Street Maintenance Program FY 2018

Sheet Legend

- Sht 1 - Cover Sheet with Vicinity Map
- G - General Sheets
- Q - Summary of Quantities
- SR - Survey Sheet and Control Points
- R - Removal Plan Sheets
- RC - Roadway Construction Plans
- GD - Grading and Drainage Plans
- ST - Pavement Marking Plans and Details
- TS - Traffic Signing Plans and Details
- U - Utility Plans and Details
- D - Miscellaneous Detail Plan Sheets
- NMDOT - New Mexico Department of Transportation Standard Drawings

City Commissioners

- Richard A. Boss, Mayor at Large
- Jason Baldwin, Mayor Pro-Tem
- Nadia Sikes
- Susan L. Payne
- Josh Rardin
- Alfonso "Al" Hernandez
- Dusty Wright



*Solutions for Today...
Vision for Tomorrow*

201 N Church Street
Suite 200A
Las Cruces, NM 88001
Phone: 575-523-2395
www.smithengineering.pro

AGENCY	PLAN REVIEW BY	DATE	DEPARTMENT	PLAN REVIEW BY	DATE	REVISIONS		
						NUMBER	DESCRIPTION	DATE
POWER NEW MEXICO			ENGINEERING					
NEW MEXICO GAS COMPANY			UTILITIES DEPARTMENT					
CENTURY LINK			STREETS AND DRAINAGE					
BAJA CABLE			FACILITY MAINTENANCE					
TULAROSA BASIN TELEPHONE COMPANY			COMMUNITY DEVELOPMENT					
OTERO COUNTY ELECTRIC COOPERATIVE			PLANNING AND ZONING					
			PARKS					
			DEPARTMENT OF PUBLIC SAFETY					

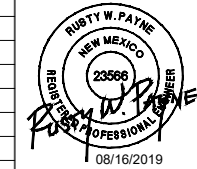

ENGINEERING DEPT.
COVER SHEET
Public Works Bid No.: 2019-002
Engineering No.: EN1803

Sheet List Table

Sheet Number	Sheet Title
--	COVER SHEET
G1.0	SHEET INDEX
G2.0	GENERAL NOTES
G3.0	RECLAIMED HYDRANT MAP
Q1.0	PROJECT SUMMARY OF QUANTITIES
SR1.0	SURVEY SHEET & CONTROL POINTS
RC1.0	CITY OF ALAMOGORDO STANDARD DETAILS
RC2.0	WASHINGTON AVENUE MILL & INLAY PLAN
RC3.0	WASHINGTON AVENUE MILL & INLAY PLAN
RC4.0	WASHINGTON AVENUE MILL & INLAY PLAN
RC5.0	WASHINGTON AVENUE MILL & INLAY PLAN
RC6.0	WASHINGTON AVENUE MILL & INLAY PLAN
RC7.0	CATALINA LANE MILL & INLAY PLAN
RC8.0	RIDGECREST DRIVE PLAN
RC9.0	RIDGECREST DRIVE PLAN
RC10.0	ALLEY PAD DETAILS
RC11.0	ALLEY PAD DETAILS
RC12.0	ALLEY PAD DETAILS
RC13.0	RUN DOWN DETAIL
GD1.0	WASHINGTON AVENUE & 11TH STREET RAMP DETAILS
GD2.0	WASHINGTON AVENUE & 12TH STREET RAMP DETAILS
GD3.0	WASHINGTON AVE. & ROOSEVELT AVE. RAMP DETAILS
GD4.0	WASHINGTON AVENUE & 14TH STREET RAMP DETAILS
GD5.0	WASHINGTON AVE. & CIRCLE DR. SOUTH RAMP DETAILS
GD6.0	WASHINGTON AVE. & CIRCLE DR. NORTH RAMP DETAILS
GD7.0	WASHINGTON AVENUE & 16TH STREET RAMP DETAILS
GD8.0	WASHINGTON AVENUE MID-BLOCK RAMP DETAILS
GD9.0	CATALINA LANE & FLORIDA AVENUE RAMP DETAILS
GD10.0	CATALINA LANE & ALASKA AVENUE RAMP DETAILS
GD11.0	CATALINA LANE & HAWAII AVENUE RAMP DETAILS
GD12.0	RIDGECREST DRIVE & SCENIC DRIVE RAMP DETAILS
ST1.0	WASHINGTON AVENUE STRIPING PLAN
ST2.0	WASHINGTON AVENUE STRIPING PLAN
ST3.0	WASHINGTON AVENUE STRIPING PLAN
ST4.0	WASHINGTON AVENUE STRIPING PLAN
ST5.0	WASHINGTON AVENUE STRIPING PLAN
U1.0	CITY OF ALAMOGORDO STANDARD DETAILS
U2.0	CITY OF ALAMOGORDO STANDARD DETAILS
U3.0	WASHINGTON AVENUE UTILITY PLAN
U4.0	WASHINGTON AVENUE UTILITY PLAN
U5.0	WASHINGTON AVENUE UTILITY PLAN
U6.0	WASHINGTON AVENUE UTILITY PLAN
U7.0	WASHINGTON AVENUE UTILITY PLAN
U8.0	WATERLINE CONNECTION DETAIL
U9.0	WATERLINE CONNECTION DETAIL
U10.0	WATERLINE CONNECTION DETAIL
U11.0	WATERLINE CONNECTION DETAIL
NMDOT-1	NMDOT STANDARD DRAWING
NMDOT-2	NMDOT STANDARD DRAWING

REV. No.	DATE	DESCRIPTION	APPROVED

New Mexico One Call, Inc. Call 2 days before you dig!
NMOC Dial 811 or 1-800-321-2537
 Professional Resources for Damage Prevention

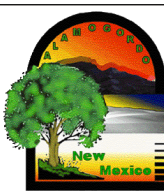

Street Maintenance Program FY2018

SHEET INDEX

CITY OF ALAMOGORDO, NEW MEXICO, ENGINEERING DEPARTMENT

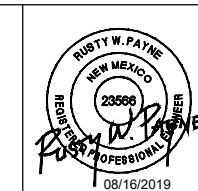

SMITH ENGINEERING
 Solutions for Today... Vision for Tomorrow
 201 N Church Street, Suite 200A
 Las Cruces, NM 88001
 Phone: 575-523-2395
 www.smithengineering.pro

Public Works Bid No.: 2019-002
Drawn By: MM Designed By: MM
Checked By: RP Approved By: COA
Scale: Horiz.: n/a Vert.: n/a
HORIZ. BAR SCALE
INCLUDE VERT SCALE ON P&P

Sheet No.: G1.0
Sheet 2 of 49
EN1803

GENERAL NOTES:

1. **SPECIFICATIONS:** THE CITY OF ALAMOGORDO TECHNICAL SPECIFICATIONS, SPECIAL PROVISIONS AND SUPPLEMENTAL SPECIFICATIONS AND THE NEW MEXICO STATE DEPARTMENT OF TRANSPORTATION (NMDOT) STANDARD SPECIFICATIONS FOR HIGHWAY AND BRIDGE CONSTRUCTION 2007 EDITION (ORANGE BOOK), NMDOT SUPPLEMENTAL SPECIFICATIONS AND REVISIONS TO THE STANDARDS SPECIFICATION FOR HIGHWAY AND BRIDGE CONSTRUCTION SHALL GOVERN CONSTRUCTION OF THIS PROJECT. SEE BID DOCUMENT MANUAL, TECHNICAL SPECIFICATIONS FOR CONTRACT DOCUMENTS ORDER OF IMPORTANCE.
2. **GENERAL NOTES:** GENERAL NOTES SHALL APPLY TO ALL SHEETS, EXCEPT WHERE MORE SPECIFIC INFORMATION IS PROVIDED. SEE INDIVIDUAL DRAWINGS FOR ADDITIONAL ABBREVIATIONS, SYMBOLS, LEGENDS, NOTES, DETAILS, AND OTHER REQUIREMENTS. IN ALL CASES, THE INFORMATION SHOWN ON INDIVIDUAL DRAWINGS SHALL GOVERN OVER ANY GENERAL INFORMATION. NOT ALL SPECIFIED ITEMS AND/OR STANDARD DETAILS SHOWN MAY BE APPLICABLE TO THIS PROJECT.
3. **MEANS, METHODS OR TECHNIQUES:** THE OWNER AND ENGINEER ARE NOT RESPONSIBLE FOR THE CONSTRUCTION MEANS, METHODS OR TECHNIQUES, NOR FOR THE EXECUTION OF THE WORK AS SHOWN ON THESE DRAWINGS. THE OWNER AND ENGINEER SHALL NOT BE RESPONSIBLE FOR THE ACTS OR OMISSIONS OF THE CONTRACTOR, SUBCONTRACTORS, OR OTHER PERSONS PERFORMING ANY OF THE WORK, OR FOR THE FAILURE OF ANY OF THE CONTRACTORS OR SUBCONTRACTORS TO CARRY OUT THE WORK IN ACCORDANCE WITH THE CONTRACT DOCUMENTS.
4. **SAFETY REQUIREMENTS:** THE CONTRACTOR IS RESPONSIBLE FOR MAINTAINING ALL WORK AREAS IN SAFE CONDITION FOR THE PUBLIC. THE CONTRACTOR SHALL BE RESPONSIBLE FOR COMPLIANCE FOR ALL CONTRACTOR PERSONNEL AND SUBCONTRACTOR PERSONNEL WITH APPLICABLE CURRENT FEDERAL, OSHA, STATE, COUNTY, AND CITY LAWS, ORDINANCES, RULES AND REGULATIONS CONCERNING SAFETY AND HEALTH. THE CONTRACTOR SHALL COMPLY WITH ALL OSHA TRENCH SAFETY RULES AND REGULATIONS APPLICABLE TO THIS PROJECT. THE CONTRACTOR SHALL INSTALL, AT A MINIMUM, SAFETY FENCING 48-INCHES IN HEIGHT AROUND THE PERIMETER OF OPEN TRENCHES AND REMOVAL AREAS. THIS WORK SHALL BE CONSIDERED INCIDENTAL TO THE COMPLETION OF THE PROJECT AND NO SEPARATE MEASUREMENT OR PAYMENT WILL BE MADE THEREFOR.
5. **CONTRACTOR RESPONSIBILITY:** THE CONTRACTOR SHALL ASSUME SOLE AND COMPLETE RESPONSIBILITY FOR THE JOB SITE CONDITIONS DURING THE COURSE OF CONSTRUCTION OF THIS PROJECT INCLUDING SAFETY OF ALL PERSONS AND PROPERTY. THESE REQUIREMENTS SHALL APPLY CONTINUOUSLY AND SHALL NOT BE LIMITED TO NORMAL WORKING HOURS. THE CONTRACTOR SHALL DEFEND, INDEMNIFY AND HOLD THE OWNER AND ENGINEER HARMLESS FROM ANY AND ALL LIABILITY, REAL OR ALLEGED, IN CONNECTION WITH THE CONTRACTORS PERFORMANCE OF WORK ON THIS PROJECT.
6. **PROJECT DEVIATIONS:** ANY PROPOSED DEVIATIONS FROM THE CONTRACT DOCUMENTS BY THE CONTRACTOR MUST BE ACCEPTED BY THE ENGINEER, IN WRITING, PRIOR TO THE WORK BEING DONE. ANY DEVIATIONS PERFORMED WITHOUT THE ENGINEER'S APPROVAL WILL NOT BE PAID FOR AND MAY BE REQUIRED TO BE RECONSTRUCTED OR REMOVED AT THE CONTRACTOR'S EXPENSE.
7. **PUBLIC ACCESS TO LOCAL BUSINESSES & RESIDENCES:** THE CONTRACTOR SHALL PROVIDE INGRESS AND EGRESS TO LOCAL BUSINESSES AND RESIDENCES FOR THE DURATION OF THE PROJECT. THE CONTRACTOR SHALL ADVISE PROPERTY OWNERS AND THE ENGINEER OF ANY ACCESS MODIFICATIONS, AT LEAST 24 HOURS IN ADVANCE. THIS WORK SHALL BE CONSIDERED INCIDENTAL TO THE COMPLETION OF THE PROJECT AND NO SEPARATE MEASUREMENT OR PAYMENT WILL BE MADE THEREFOR.
8. **PERMITTING:** IT SHALL BE THE CONTRACTOR'S RESPONSIBILITY TO REQUEST AND OBTAIN ALL PERMITS NECESSARY FOR THIS PROJECT PRIOR TO COMMENCING CONSTRUCTION. CONTRACTOR SHALL COMPLY WITH ALL APPLICABLE CURRENT FEDERAL, OSHA, STATE, COUNTY, AND CITY LAWS, ORDINANCES, RULES AND REGULATIONS.
9. **MAINTENANCE OF AS-BUILT PLANS:** THE CONTRACTOR SHALL MAINTAIN AN UP TO DATE SET OF AS-BUILT PLANS FOR THE PROJECT. THESE PLANS SHALL BE KEPT CURRENT, WITHIN ONE-WEEK, AT ALL TIMES AND SHALL BE SUBJECT TO REVIEW BY THE ENGINEER THROUGHOUT THE PROJECT AND WILL BE REVIEWED BY THE ENGINEER FOR ACCURACY AND COMPLETENESS AT LEAST ONCE EVERY 7-DAYS. THE FINAL AS-BUILT PLANS SHALL BE SUBMITTED TO THE ENGINEER PRIOR TO FINAL PAYMENT. FINAL AS-BUILT PLANS SHALL BE DELIVERED IN CLEAN HARD COPY. CONTRACTOR CERTIFICATION SHALL BE CLEARLY STATED ON THE COVER SHEET. THIS WORK SHALL BE CONSIDERED INCIDENTAL TO THE PROJECT AND NO SEPARATE MEASUREMENT OR PAYMENT WILL BE MADE THEREFOR.
10. **WATER FOR CONSTRUCTION:** THE CONTRACTOR WILL BE RESPONSIBLE FOR PURCHASING ALL OF THE RECLAIMED WATER NEEDED FOR CONSTRUCTION FROM THE CITY OF ALAMOGORDO. THE COST WILL BE DETERMINED IN ACCORDANCE WITH THE CURRENT RECLAIMED WATER RATES. IT SHALL BE THE CONTRACTOR'S RESPONSIBILITY TO TRANSPORT AND APPLY THE RECLAIMED WATER AS SPECIFIED OR AS ORDERED BY THE ENGINEER. THE CONTRACTOR SHALL COORDINATE WITH THE ENGINEER FOR LOCATION OF SOURCES. THIS COST SHALL BE CONSIDERED INCIDENTAL TO THE PROJECT AND NO SEPARATE MEASUREMENT OF PAYMENT WILL BE MADE THEREFORE.
11. **INTERRUPTION OF SERVICE:** CONTRACTOR MUST MAINTAIN WATER SERVICE AT ALL TIMES AS DIRECTED BY THE ENGINEER. IF AN INTERRUPTION OF SERVICE IS UNAVOIDABLE, THE CONTRACTOR SHALL NOTIFY ALL AFFECTED RESIDENTS ON A DOOR-TO-DOOR BASIS OR AS AGREED WITH THE ENGINEER. CONTRACTOR SHALL COORDINATE WITH THE ENGINEER FOR ALL WATER SHUT-OFFS.
12. **EARTHWORK HAUL:** THE EARTHWORK HAUL ON THIS PROJECT WILL BE CONSIDERED AS INCLUDED IN THE CONTRACT PRICE FOR ITEMS "UNCLASSIFIED EXCAVATION", AND "BORROW", AS APPLICABLE, AND NO SEPARATE MEASUREMENT OR PAYMENT WILL BE MADE FOR HAUL.
13. **PAVEMENT DROP-OFF POLICY:** IF A PAVEMENT DROP-OFF IS CREATED DURING CONSTRUCTION, THE CONTRACTOR SHALL INITIATE PROTECTIVE ACTION IN ACCORDANCE WITH THE NMDOT'S CURRENT "DROP-OFF POLICY". THE POLICY IS AVAILABLE FROM THE ENGINEER. THIS WORK SHALL BE CONSIDERED INCIDENTAL TO THE COMPLETION OF THE PROJECT AND NO SEPARATE MEASUREMENT OR PAYMENT WILL BE MADE THEREFOR.
14. **WARPING OF SLOPES:** THE CONTRACTOR SHALL WARP SLOPES WHERE NECESSARY TO STAY WITHIN THE RIGHT OF WAY OR CONSTRUCTION EASEMENT LIMITS.
15. **MATERIAL PITS:** NO MATERIAL PITS HAVE BEEN DESIGNATED FOR THIS PROJECT. THE CONTRACTOR MAY OBTAIN SPECIFICATION BORROW OR SURFACING MATERIAL FROM ANY ACCEPTABLE SOURCE. ALL MATERIAL PITS SHALL BE GOVERNED BY SECTION 106 OF THE NMDOT STANDARD SPECIFICATIONS.

16. **CONSTRUCTION EQUIPMENT & MATERIAL STORAGE:** THE CONTRACTOR SHALL NOT STORE EQUIPMENT OR MATERIAL WITHIN 28 FEET FROM THE EDGE OF THE DRIVING LANE UNLESS THE EQUIPMENT OR MATERIAL IS PROPERLY SHIELDED UTILIZING CURRENT SAFETY DESIGN AND INSTALLATION METHODS. ALL EQUIPMENT AND MATERIAL STORED IN STAGING YARD SHALL BE PROPERLY SHIELDED UTILIZING CURRENT SAFETY DESIGN AND INSTALLATION METHODS. IN NO CASE SHALL THE CONTRACTOR STORE EQUIPMENT OR MATERIAL IN THE DRIVING LANE. THE SAFETY DESIGN FOR SHIELDING SHALL BE PROVIDED BY THE CONTRACTOR AND MUST BE APPROVED BY THE ENGINEER BEFORE IMPLEMENTING. THIS WORK, INCLUDING DESIGN, INSTALLATION AND REMOVAL OF THE SHIELDING, SHALL BE CONSIDERED INCIDENTAL TO THE COMPLETION OF THE PROJECT AND NO SEPARATE MEASUREMENT OR PAYMENT WILL BE MADE THEREFOR.
17. **PROTECTION OF SURVEY MONUMENTS:** THE CONTRACTOR SHALL TAKE PRECAUTIONS TO PROTECT HORIZONTAL AND VERTICAL CONTROL SURVEY MONUMENTS AND CONTROL POINTS FROM DAMAGE PRIOR TO INITIATING CONSTRUCTION. AN INVENTORY OF THE EXISTING MONUMENTS WILL BE TAKEN BY THE ENGINEER AND THE CONTRACTOR PRIOR TO START OF CONSTRUCTION. IF, DURING THE COURSE OF CONSTRUCTION OPERATIONS, THE CONTRACTOR DISTURBS OR DESTROYS A MARK, THE CONTRACTOR SHALL ESTABLISH A NEW MARK IN COMPLIANCE WITH THE STANDARDS AND PROCEDURES SET FORTH IN THE "GEODETIC MARK PRESERVATION GUIDEBOOK ". NATIONAL GEODETIC SURVEY, MARCH 1990, CONTACT: NGS MARK PRESERVATION CENTER-NOAA, TELEPHONE (505) 768-3606.
18. **REMOVALS:** THE CONTRACTOR SHALL BE RESPONSIBLE FOR ALL REMOVALS REQUIRED TO COMPLETE THE PROJECT. REMOVALS NOT SHOWN ON THE PLANS WILL BE DESIGNATED BY THE ENGINEER. THIS WORK WILL BE CONSIDERED AS INCLUDED IN THE CONTRACT PRICE FOR ITEM "REMOVAL OF STRUCTURES AND OBSTRUCTIONS" AND THE CONTRACTOR WILL NOT RECEIVE ADDITIONAL COMPENSATION FOR UNLISTED REMOVALS. ITEMS THAT ARE SCHEDULED TO BE REMOVED AND REPLACED SHALL BE REPLACED WITH-IN SEVEN (7) DAYS OF THEIR REMOVAL.
19. **SAW CUTTING:** CONTRACTOR SHALL SAW CUT PAVEMENT, CONCRETE SIDEWALK, CONCRETE DRIVE WAYS AND CURB AND GUTTER AT TIE-INS AS REQUIRED FOR A SMOOTH TRANSITION. THIS WORK WILL BE CONSIDERED INCIDENTAL TO THE COMPLETION OF THE PROJECT AND NO SEPARATE MEASUREMENT OR PAYMENT WILL BE MADE THEREFOR.
20. **SALVAGEABLE MATERIALS:** SALVAGEABLE MATERIALS FROM THIS PROJECT ARE TO BE HAULED AND STOCK PILED AT THE CITY YARD LOCATED AT 2600 N. FLORIDA AVENUE. HAUL OF SUCH MATERIAL SHALL BE PERFORMED DURING NORMAL WORKING HOURS AS DIRECTED BY THE ENGINEER. PAYMENT FOR THIS WORK SHALL BE INCLUDED IN THE CONTRACT PRICE FOR ITEM "REMOVAL OF STRUCTURES AND OBSTRUCTIONS.
21. **WASTE MATERIALS:** WASTE MATERIAL MUST BE DISPOSED OF AT A STATE APPROVED SITE.
22. **PROTECTION OF EXISTING UTILITIES:** THE CONTRACTOR IS RESPONSIBLE FOR LOCATING AND PROTECTING ALL UNDERGROUND AND OVERHEAD UTILITIES AND SHALL COORDINATE ALL WORK WITH UTILITY OWNERS. ALL IMPROVEMENTS WHICH ARE DAMAGED BY THE CONTRACTOR'S OPERATIONS SHALL BE REPAIRED, RECONSTRUCTED OR REPLACED WITHIN 24 HOURS TO THE ENGINEER'S SATISFACTION AT THE CONTRACTOR'S EXPENSE WITHOUT ADDITIONAL COMPENSATION.
23. **CONTRACTOR COORDINATION WITH UTILITIES:** THE CONTRACTOR IS HEREBY ADVISED THAT UTILITY RELOCATION WORK BY THE UTILITY OWNERS MAY BE PERFORMED CONCURRENT WITH CONSTRUCTION. THE CONTRACTOR SHALL PROVIDE FOR UTILITY WORK IN CONJUNCTION WITH CONSTRUCTION OPERATIONS AND SHALL BE REQUIRED TO COORDINATE THE SCHEDULING OF WORK WITH THE RESPECTIVE UTILITY OWNERS. ANY CLAIMS FOR DELAY SHALL BE CONTROLLED BY THE TERMS AND CONDITIONS OF THE NMDOT STANDARD SPECIFICATIONS FOR HIGHWAY AND BRIDGE CONSTRUCTION.
24. **VERIFY ELEVATIONS:** THE CONTRACTOR SHALL EMPLOY A LICENSED NEW MEXICO SURVEYOR AND SHALL FIELD VERIFY ALL ELEVATIONS, DIMENSIONS, AND RIGHT-OF-WAY PRIOR TO THE BEGINNING OF CONSTRUCTION. THE ELEVATIONS WERE BASED ON AS-BUILT AND FIELD SURVEY DATA. THE CONTRACTOR SHALL LIMIT ALL WORK ON THIS PROJECT TO WITHIN THE EXISTING RIGHT-OF-WAY AND EASEMENTS. THIS WORK WILL BE CONSIDERED INCIDENTAL TO CONSTRUCTION STAKING BID ITEM AND TO THE COMPLETION OF THE PROJECT, NO SEPARATE MEASUREMENT OR PAYMENT WILL BE MADE.
25. **UTILITY DISCLAIMER:** UTILITY LOCATIONS SHOWN HEREON ARE BASED ON THE BEST AVAILABLE EVIDENCE INCLUDING PHYSICAL FEATURES SUCH AS VALVES, PEDESTALS, WARNING MARKERS AND SPOTS BY UTILITY LOCATING SERVICES. THERE IS NO GUARANTEE AS TO THE COMPLETENESS OR ACCURACY OF THE UTILITY DATA SHOWN ON THE PLANS. THE CONTRACTOR SHALL CONTACT ALL UTILITY OWNERS TO VERIFY THE HORIZONTAL AND VERTICAL LOCATIONS OF ALL UTILITIES. SHOULD A CONFLICT EXIST, THE CONTRACTOR SHALL NOTIFY THE ENGINEER OF THE CONFLICT WITH MINIMUM DELAY. EXCAVATION TO VERIFY LOCATIONS SHALL BE CONSIDERED INCIDENTAL TO THE COMPLETION OF THE PROJECT, NO SEPARATE MEASUREMENT OR PAYMENT WILL BE MADE.
26. **TRAFFIC CONTROL:** THE CONTRACTOR SHALL MAINTAIN AND CONTROL TRAFFIC AS OUTLINED IN THE "MUTCD, LATEST EDITION" DURING CONSTRUCTION. ANY NECESSARY DEVIATION FROM THE "MUTCD, LATEST EDITION" SHALL HAVE PRIOR APPROVAL OF THE ENGINEER. THE CONTRACTOR SHALL SUBMIT A COPY OF TRAFFIC CONTROL PLAN TO THE ENGINEER FOR APPROVAL, PRIOR TO START OF CONSTRUCTION.
27. **TRUCK WEIGHT:** MAXIMUM WEIGHT OF TRUCKS SHALL CONFORM TO N.M.D.O.T. STANDARDS. CONTRACTOR TO REPLACE ANY DAMAGED STREETS USED DURING CONSTRUCTION HAULING. REPLACEMENT OF DAMAGED STREETS SHALL BE CONSIDERED INCIDENTAL TO THE COMPLETION OF THE PROJECT, NO SEPARATE MEASUREMENT OR PAYMENT WILL BE MADE.
28. **WORK CONFINEMENT:** THE CONTRACTOR SHALL BE REQUIRED TO CONFINE HIS WORK WITHIN THE CONSTRUCTION LIMITS OR RIGHT-OF-WAY. PARKING OF EMPLOYEE'S PRIVATE VEHICLES SHALL NOT BE ALLOWED ALONG CONSTRUCTION AREAS THROUGHOUT CONSTRUCTION LIMITS. IT SHALL BE THE CONTRACTOR'S RESPONSIBILITY TO PROHIBIT ASPHALT VEHICLES AND EQUIPMENT, ROLLERS, CRANES, ETC., FROM DRIVING UPON, ACROSS, OR TURNING ON PRIVATE PROPERTY ADJACENT TO PROJECT WORK AREAS.
29. **SURFACE FEATURES:** CONTRACTOR SHALL REPAIR OR REPLACE FENCES, BLOCK WALLS, OR SURFACE FEATURES, DAMAGED BY CONTRACTOR'S OR SUBCONTRACTOR'S OPERATIONS, TO EXISTING OR BETTER CONDITION. REPAIR OR REPLACEMENT OF FENCES, BLOCK WALLS, OR SURFACE FEATURES SHALL BE CONSIDERED INCIDENTAL TO THE COMPLETION OF THE PROJECT AND NO SEPARATE MEASUREMENT OR PAYMENT WILL BE MADE THEREFOR.

30. **PROJECT VIDEO:** PRIOR TO INITIATING CONSTRUCTION OPERATIONS, CONTRACTOR, SHALL PERFORM DIGITAL VIDEO RECORDING OF THE ENTIRE PROJECT, ITS FULL LENGTH AND WIDTH. THE CONTRACTOR, SHALL ALSO INCLUDE OR ADD AS NECESSARY, ANY AREAS TO BE DISTURBED FOR MATERIAL STORAGE, EMPLOYEE PARKING OR EQUIPMENT STORAGE.

THE VIDEO DOCUMENTATION SHALL BE COMPLETED IN DIGITAL FORMAT; IT SHALL BE A MINIMUM RESOLUTION OF 1920 X 1080 PIXELS, AT 60 FPS (FRAME PER SECOND) AND IN COLOR. THE VIDEO DOCUMENTATION SHALL BE PERFORMED BETWEEN 10:00 A.M. AND 2:00 P.M. DURING PERIODS OF FULL SUN EXPOSURE. THE ACTUAL DATE OF RECORDING SHALL BE DATE-STAMPED WITHIN EACH FRAME OF THE VIDEO. APPROVAL OF THE VIDEO MUST BE OBTAINED FROM THE ENGINEER PRIOR TO THE COMMENCEMENT OF ANY CLEARING AND GRUBBING OPERATIONS.

A DVD COPY OF THE VIDEO RECORDING SHALL BE SUBMITTED TO THE ENGINEER, IN A FORMAT COMPATIBLE WITH STANDARD DVD PLAYERS.

ALL COST ASSOCIATED WITH THE VIDEO RECORDING SPECIFIED IN THIS ARTICLE SHALL BE CONSIDERED INCIDENTAL TO OTHER RELATED ITEMS OF WORK AND NO SEPARATE PAYMENT WILL BE MADE UNLESS SPECIFICALLY INDICATED ELSEWHERE IN THE SPECIAL PROVISIONS.
31. **SITE CLEAN UP:** PROJECT SITE(S) AND YARD(S) SHALL BE MAINTAINED BY CONTRACTOR AND KEPT IN A CLEAN AND ORDERLY MANNER TO THE SATISFACTION OF THE ENGINEER. THIS WORK SHALL BE CONSIDERED INCIDENTAL TO THE COMPLETION OF THE PROJECT AND NO SEPARATE MEASUREMENT OR PAYMENT WILL BE MADE THEREFOR.

UTILITY COMPANY CONTACTS:

CITY OF ALAMOGORDO:
 WATER/SEWER: DAVE NUNNELLEY – 575.430.1947
 FACILITY/FIBER OPTIC: PAUL BENNETT – 575.921.4402
 PARK SUPERVISOR: ERIK MARION – 575.439.4139

PNM ELECTRIC: (OFFICE) 575.443.6610
 WILSON GUIN 575.430.2977
 LORNE WOFFORD 575.430.8380

NEW MEXICO GAS COMPANY: NATURAL GAS (OFFICE) 1.888.664.2726
 TIM TURRI 575.443.6424
 MARIO ESTRADA 575.430.8381
 ORLANDO MARTINEZ 575.202.9545

TELEPHONE (CENTURY LINK): GARY NELSON (O) 575.767.7467

REV. No.	DATE	DESCRIPTION	APPROVED

New Mexico One Call, Inc. Call 2 days before you dig!

 Professional Resources for Damage Prevention Dial 811 or 1-800-321-2537

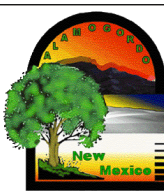

Street Maintenance Program FY2018

GENERAL NOTES

CITY OF ALAMOGORDO, NEW MEXICO, ENGINEERING DEPARTMENT



Public Works Bid No.: 2019-002	Sheet No.:
Drawn By: COA Designed By: COA	G2.0
Checked By: COA Approved By: COA	Sheet 3 of 49
Scale: Horiz.: n/a Vert.: n/a	EN1803
HORIZ. BAR SCALE	
INCLUDE VERT SCALE ON P&P	

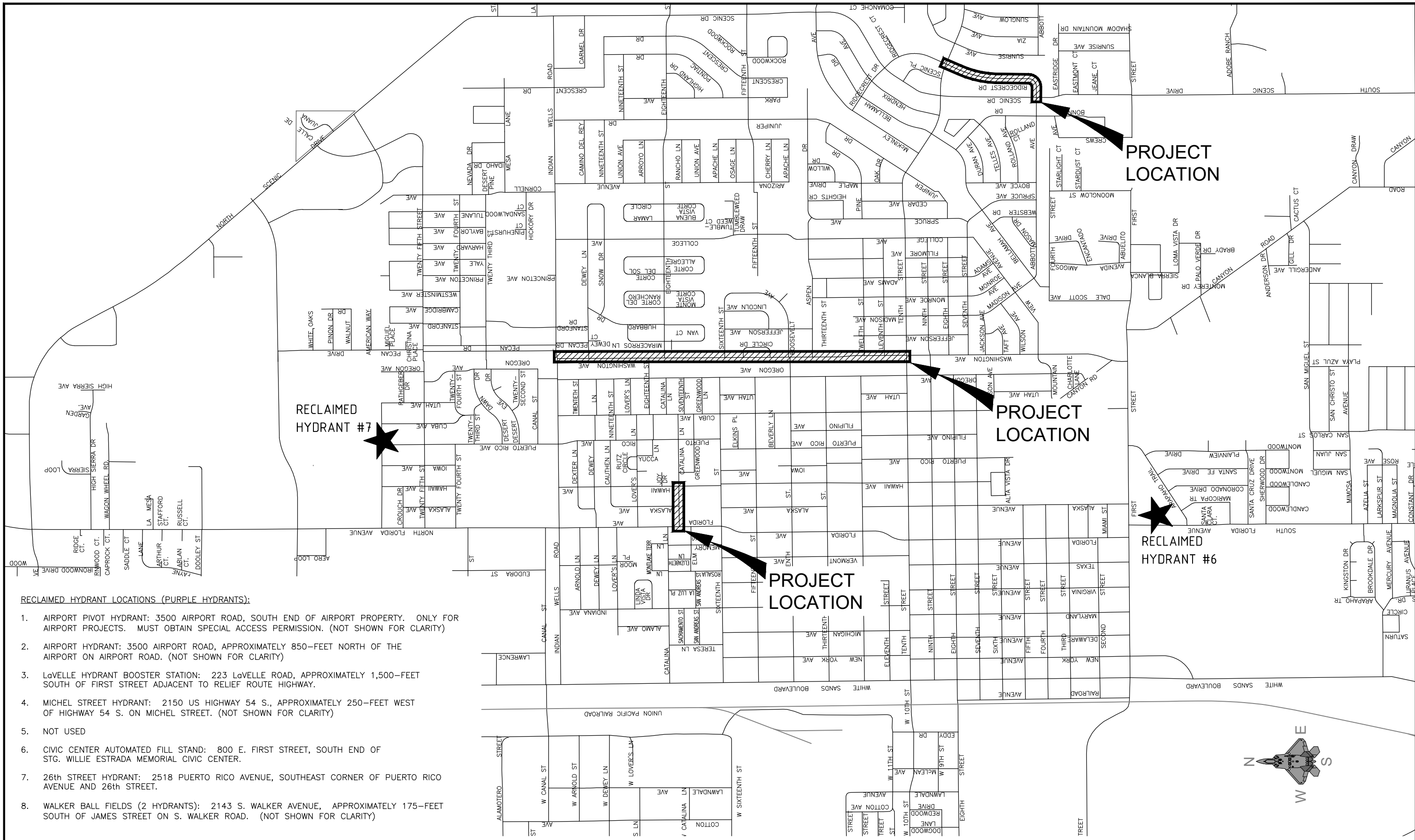

RECLAIMED HYDRANT LOCATIONS (PURPLE HYDRANTS):

1. AIRPORT PIVOT HYDRANT: 3500 AIRPORT ROAD, SOUTH END OF AIRPORT PROPERTY. ONLY FOR AIRPORT PROJECTS. MUST OBTAIN SPECIAL ACCESS PERMISSION. (NOT SHOWN FOR CLARITY)
2. AIRPORT HYDRANT: 3500 AIRPORT ROAD, APPROXIMATELY 850- FEET NORTH OF THE AIRPORT ON AIRPORT ROAD. (NOT SHOWN FOR CLARITY)
3. LaVELLE HYDRANT BOOSTER STATION: 223 LaVELLE ROAD, APPROXIMATELY 1,500- FEET SOUTH OF FIRST STREET ADJACENT TO RELIEF ROUTE HIGHWAY.
4. MICHEL STREET HYDRANT: 2150 US HIGHWAY 54 S., APPROXIMATELY 250- FEET WEST OF HIGHWAY 54 S. ON MICHEL STREET. (NOT SHOWN FOR CLARITY)
5. NOT USED
6. CIVIC CENTER AUTOMATED FILL STAND: 800 E. FIRST STREET, SOUTH END OF STG. WILLIE ESTRADA MEMORIAL CIVIC CENTER.
7. 26th STREET HYDRANT: 2518 PUERTO RICO AVENUE, SOUTHEAST CORNER OF PUERTO RICO AVENUE AND 26th STREET.
8. WALKER BALL FIELDS (2 HYDRANTS): 2143 S. WALKER AVENUE, APPROXIMATELY 175- FEET SOUTH OF JAMES STREET ON S. WALKER ROAD. (NOT SHOWN FOR CLARITY)

REV. NO.	DATE	DESCRIPTION	APPROVED

New Mexico One Call, Inc. Call 2 days before you dig!
NMOC Dial 811 or 1-800-321-2537
 Professional Resources for Damage Prevention



Street Maintenance Program FY2018
RECLAIMED HYDRANT MAP
 CITY OF ALAMOGORDO, NEW MEXICO, ENGINEERING DEPARTMENT

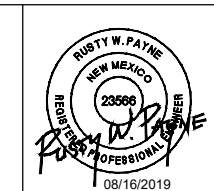

SMITH ENGINEERING
 Solutions for Today... Vision for Tomorrow
 201 N Church Street Suite 200A Las Cruces, NM 88001 Phone: 575-523-2395 www.smithengineering.pro

Public Works Bid No.: 2019-002
 Drawn By: COA Designed By: COA
 Checked By: COA Approved By: COA
 Scale: Horiz.: n/a Vert.: n/a
 HORIZ. BAR SCALE
 INCLUDE VERT SCALE ON P&P

Sheet No.: **G3.0**
 Sheet 4 of 49
 EN1803

SUMMARY OF QUANTITIES - BASE BID:

BASE BID (WASHINGTON AVENUE, CATALINA LANE, RIDGECREST DRIVE-RAMPS ONLY)				
ITEM NO.	DESCRIPTION	UNIT	ESTIMATED QUANTITY	FINAL QUANTITY
201000	CLEARING AND GRUBBING; COMPL	L.S.	1	
203000	UNCLASSIFIED EXCAVATION; CIP	C.Y.	100	
207000	8" SUBGRADE PREPARATION; CIP	S.Y.	410	
303180	8" BASE COURSE; CIP	S.Y.	410	
414120	2" THICK HMA COLD MILLING; CIP	S.Y.	22,740	
423269	HMA SP-IV 1 1/2 INCHES THICK; CIP	S.Y.	16	
423270	HMA SP-IV 2-INCHES THICK; CIP	S.Y.	22,740	
423270	HMA SP-IV 3-INCHES THICK; CIP	S.Y.	410	
607079	PEDESTRIAN/BICYCLE RAILING; CIP	L.F.	72	
608000	TACTILE WARNING SURFACE; CIP	S.F.	240	
608104	4-INCH THICK CONCRETE; CIP	S.Y.	440	
608106	6-INCH THICK CONCRETE; CIP	S.Y.	460	
609424	TYPE II CURB/GUTTER; CIP	L.F.	1,470	
618000	FURNISH & PROVIDE MUTCD PLAN; COMPL	L.S.	1	
621000	MOBILIZATION; COMPL	L.S.	1	
662400	ADJUST EXISTING MANHOLE TO FINAL GRADE; CIP	EA	8	
663100	NEW FIRE HYDRANT; CIP	EA	1	
663711	3/4-INCH SERVICE LINE REPLACEMENT; CIP	EA	32	
663712	2-INCH SERVICE LINE REPLACEMENT; CIP	EA	1	
663726	6-INCH PVC WATERLINE; CIP	L.F.	440	
663728	8-INCH PVC WATERLINE; CIP	L.F.	240	
663770	CUT & CAP WATERLINE; CIP	EA	16	
663772	DRY LATERAL WATERLINE CONNECTION; CIP	EA	21	
663855	ADJUST EXISTING VALVE BOX TO GRADE; CIP	EA	39	
663856	REMOVE & SALVAGE EXISTING VALVE BOX; COMPL	EA	13	
663887	WET LATERAL WATERLINE CONNECTION; CIP	EA	2	
663896	6-INCH MAINLINE GATE VALVE; CIP	EA	9	
663898	8-INCH MAINLINE GATE VALVE; CIP	EA	18	
663900	CONCRETE ENCASEMENT; CIP	LF	80	
704224	RETROREFLECTORIZED PLASTIC PAVEMENT STRIPE 24-INCHES WIDE; CIP	L.F.	240	
704700	HOT THERMOPLASTIC PAVEMENT STRIPE 4-INCHES WIDE; CIP	L.F.	10,000	
704715	HOT THERMOPLASTIC PAVEMENT MARKING COMBINATION (THRU AND RIGHT) ARROW; CIP	EA	2	
704718	HOT THERMOPLASTIC PAVEMENT MARKING LEFT ARROW; CIP	EA	2	
704720	HOT THERMOPLASTIC PAVEMENT MARKING WORD (ONLY); CIP	EA	1	
801000	CONSTRUCTION STAKING & SURVEYING; COMPL	L.S.	1	

SUMMARY OF QUANTITIES - ADDITIVE ALTERNATE #1:

ADDITIVE ALTERNATE #1 (WASHINGTON AVENUE CURB & RUNDOWNS)				
ITEM NO.	DESCRIPTION	UNIT	ESTIMATED QUANTITY	FINAL QUANTITY
605300	CONCRETE RUNDOWN STRUCTURE; COMPL	EA	4	
609424	TYPE II CURB/GUTTER; CIP	L.F.	2,460	
609425	SIDEWALK TRENCH GRATE; CIP	EA	1	

SUMMARY OF QUANTITIES - ADDITIVE ALTERNATE #2:

ADDITIVE ALTERNATE #2 (RIDGECREST DRIVE PAVING IMPROVEMENTS)				
ITEM NO.	DESCRIPTION	UNIT	ESTIMATED QUANTITY	FINAL QUANTITY
414120	2" THICK HMA COLD MILLING; CIP	S.Y.	5,370	
423270	HMA SP-IV 2-INCHES THICK; CIP	S.Y.	5,370	
662400	ADJUST EXISTING MANHOLE TO FINAL GRADE; CIP	EA	5	
663855	ADJUST EXISTING VALVE BOX TO GRADE; CIP	EA	2	

REV. No.	DATE	DESCRIPTION	APPROVED

New Mexico One Call, Inc. Call 2 days before you dig!
NMOC Dial 811 or 1-800-321-2537
 Professional Resources for Damage Prevention



Street Maintenance Program FY2018

PROJECT SUMMARY OF QUANTITIES
 CITY OF ALAMOGORDO, NEW MEXICO, ENGINEERING DEPARTMENT

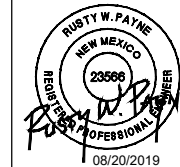

Public Works Bid No.: 2019-002
 Drawn By: MM Designed By: MM
 Checked By: RP Approved By: COA
 Scale: HORIZ. BAR SCALE
 INCLUDE VERT SCALE ON P&P

Sheet No.: **Q1.0**
 Sheet 5 of 49
 EN1803

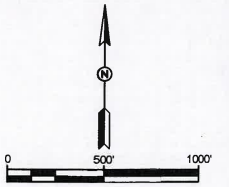

FLORIDA AVE
ALASKA AVE
HAWAII AVE
CATALINA DR

INDIAN WELLS RD
DEWEY LN
18TH ST
WASHINGTON AVENUE
18TH ST
16TH ST
CIRCLE DR
CIRCLE DR
14TH ST
ROOSEVELT AVE
ASPEN DR
13TH ST
12TH ST
11TH ST
10TH ST
9TH ST
8TH ST
7TH ST
JACKSON AVE
TAFT AVE
WILSON AVE

MCKINLEY CHANNEL

NO.:10003
N:691073.204
E:1737542.999
ELEV:4468.12
DESC: PBM 4

NO.:10002
N:693968.633
E:1742166.490
ELEV:4636.00
DESC: PBM 3

NO.:10001
N:691807.750
E:1742380.652
ELEV:4603.70
DESC: COA117A011

NO.:10005
N:684858.941
E:1728703.753
ELEV:4310.84
DESC: PBM 11

NO.:10004
N:685031.484
E:1731703.964
ELEV:4380.13
DESC: PBM 7

SURVEY CONTROL NOTES:
GRID TO GROUND FACTOR = 1.000317510
BENCHMARKS ARE CORPS OF ENGINEERS BRASS CAPS IN CONCRETE

VERTICAL BENCHMARK DATUM IS BASED ON NAVD 88.
HORIZONTAL CONTROL IS BASED ON NAD 83.
BENCHMARK COORDINATES ARE GRID COORDINATES IN FEET AND ARE BASED ON THE NEW MEXICO STATE PLANE COORDINATE SYSTEM, CENTRAL ZONE.

SCENIC DR
RIDGECREST DR

REV. No.	DATE	DESCRIPTION	APPROVED

New Mexico One Call, Inc. Call 2 days before you dig!

 Professional Resources for Damage Prevention Dial 811 or 1-800-321-2537



Street Maintenance Program FY2018

SURVEY SHEET & CONTROL POINTS

CITY OF ALAMOGORDO, NEW MEXICO, ENGINEERING DEPARTMENT

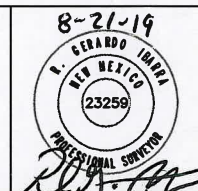

SMITH ENGINEERS
 Solutions for Today... Vision for Tomorrow
 201 N Church Street Suite 200A
 Las Cruces, NM 88001
 Phone: 575-523-2395
 www.smithengineering.pro

Public Works Bid No.: 2019-002
Drawn By: SMITH Designed By: PLS
Checked By: PLS Approved By: COA
Scale: HORIZ. BAR SCALE INCLUDE VERT SCALE ON P&P

Sheet No.: SR1.0
Sheet 6 of 49
EN1803

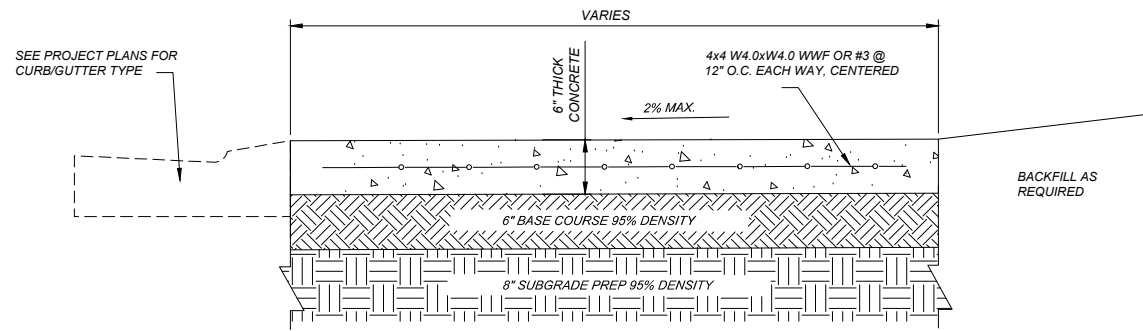

6" Thick Reinforced Concrete

No Scale

GENERAL NOTES:

- CROSS SLOPE SHALL NOT EXCEED 2% MAXIMUM.
- RAMP SLOPE SHALL NOT EXCEED 8.3% MAXIMUM.
- CONTRACTOR SHALL FIELD VERIFY CROSS SLOPE AND RAMP SLOPE AND COORDINATE WITH ENGINEER ITEMS THAT MAY EXCEED THESE MAXIMUM REQUIREMENTS.
- COORDINATE WITH OWNER/ENGINEER LIMITS OF REMOVAL.
- COORDINATE WITH OWNER/ENGINEER LIMITS OF BACKFILL REQUIREMENTS.

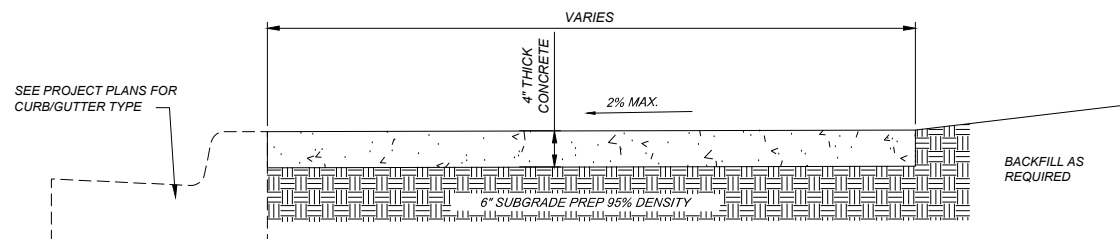

4" Thick Concrete

No Scale

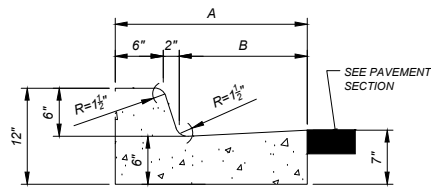

STANDARD CURB & GUTTER

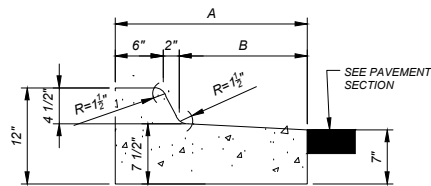

REVERSE SLOPE CURB & GUTTER

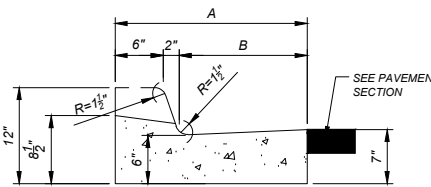

LAY-DOWN CURB & GUTTER

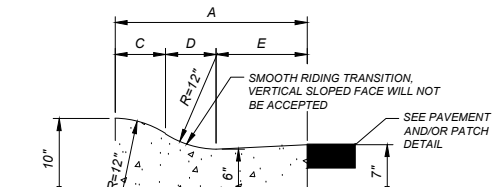

MOUNTABLE CURB & GUTTER

CURB & GUTTER LEGEND			
TYPE	I	II	III
A	18"	24"	30"
B	10"	16"	22"
C	5.5/8"	5.5/8"	5.5/8"
D	5"	7"	7"
E	7.3/8"	11.3/8"	17.3/8"

TYPICAL CURB AND GUTTER DETAIL

No Scale

GENERAL NOTES:

- NEW CURB/GUTTER PROFILE SHALL MATCH EXISTING ADJACENT CURB AND GUTTER AND/OR STREET PROFILE.
- NEW CURB/GUTTER SHALL INCLUDE 8-INCH SUB-GRADE PREP.
- NEW CURB/GUTTER SHALL INCLUDE 6-INCH BASE COURSE.
- EDGES OF CURB/GUTTER NOT SPECIFICALLY DIMENSIONED SHALL BE EDGED WITH A 3/8" EDGING TOOL.
- DIMENSIONS AT ROUNDED CORNERS MEASURED TO INTERSECTION OF STRAIGHT LINES.
- PROVIDE CONTROL JOINTS EVERY 5'-0". CONTROL JOINT SHALL BE TOOL JOINTED WITH TOP ROUND EDGE OF 1/8-INCH RADIUS. DEPTH OF 1-INCH. THE FINISH JOINT OPENING EXCLUDING RADI SHALL NOT BE WIDER THAN 1/8-INCH.
- PROVIDE 1/2" EXPANSION JOINTS EVERY 50'-0", ALONG CURB AND GUTTER.
- TACK COAT EDGE OF GUTTER PRIOR TO PLACEMENT OF NEW PAVEMENT/PAVEMENT PATCH.
- THE CONSTRUCTION OF CURB & GUTTER AND/OR PAVEMENT SHALL BE CONSTRUCTED SO THAT THE GUTTER FLOW WILL BE CONSTANT (NO PONDING AREAS WILL BE ACCEPTED).



2-inch Pavement Mill/Overlay Section

No Scale

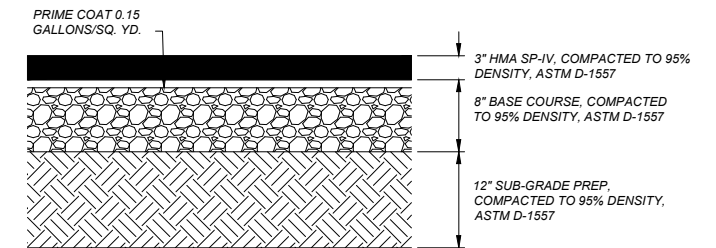

Typical Pavement Section

No Scale

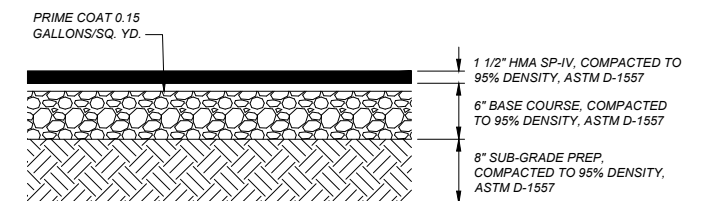

Incidental Pavement Section

No Scale

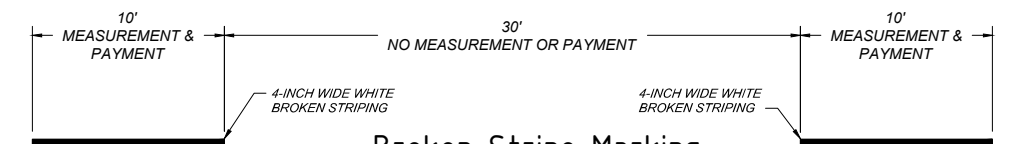

Broken Stripe Marking

CONTRACTOR NOTE:

- CROSSWALK AND STOP BARS SHALL BE 3M-N380 PREFORMED PATTERNED MARKING OR APPROVED EQUAL (O.A.E.).
- ALIGN CROSSWALK WITH CENTERLINE OF WHEEL PATH, COORDINATE WITH OWNER PRIOR TO INSTALLATION.
- SYMBOLS AND LEGENDS SHALL BE 3M-380IES PREFORMED PATTERNED MARKING O.A.E.
- BROKEN STRIPING, DOUBLE STRIPING AND SINGLE STRIPING SHALL BE 90 MIL HOT THERMOPLASTIC PAVEMENT STRIPING.
- MEASUREMENT AND PAYMENT FOR BROKEN STRIPING (10 LF) SHALL BE CALCULATED BY MATERIAL USED.

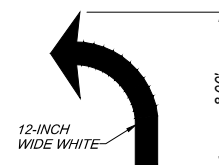

Turn Arrow

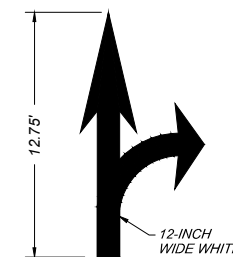

Combo Arrow

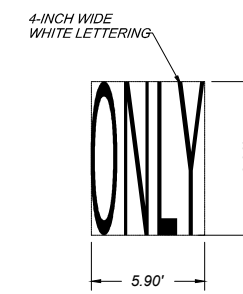

Word " ONLY "

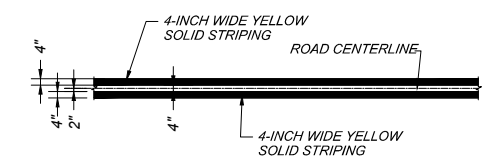

Double Yellow Marking

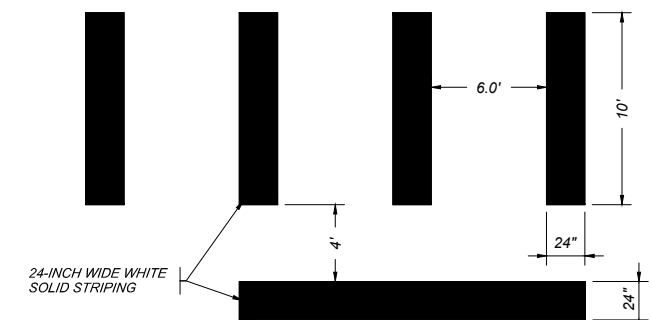

Crosswalk and Stop Bar

Street Maintenance Program FY2018

CITY OF ALAMOGORDO STANDARD DETAILS
CITY OF ALAMOGORDO, NEW MEXICO, ENGINEERING DEPARTMENT

New Mexico One Call, Inc. Call 2 days before you dig!
Dial 811 or 1-800-321-2537
Professional Resources for Damage Prevention

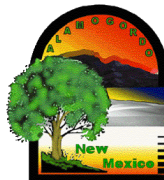

SMITH ENGINEERING
Solutions for Today... Vision for Tomorrow
201 N Church Street
Suite 200A
Las Cruces, NM 88001
Phone: 575-523-2395
www.smithengineering.pro

Public Works Bid No.: 2019-002
Drawn By: COA Designed By: COA
Checked By: COA Approved By: COA
Scale: Horiz.: n/a Vert.: n/a
HORIZ. BAR SCALE
INCLUDE VERT SCALE ON P&P

Sheet No.: RC1.0
Sheet 7 of 49
EN1803

REV. NO.	DATE	DESCRIPTION	APPROVED

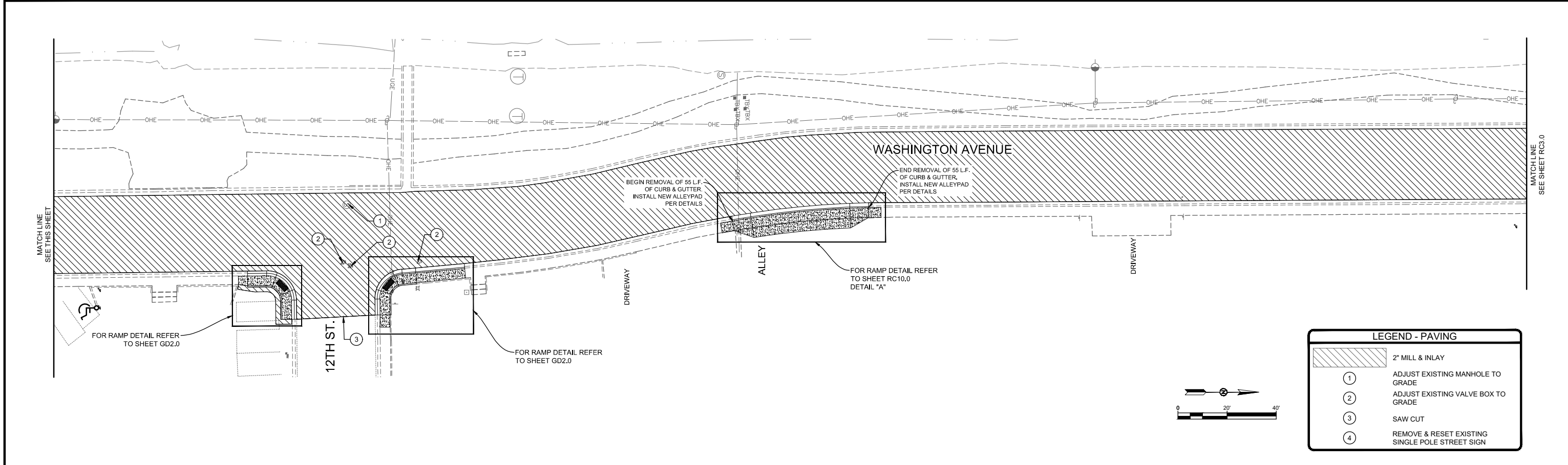
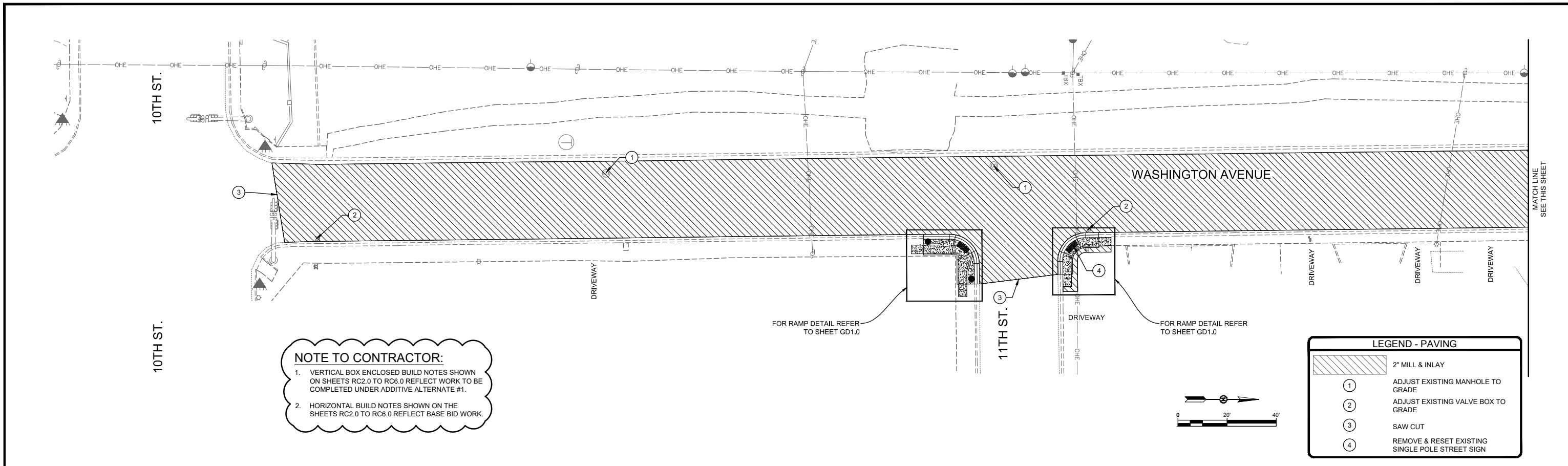

REV. No.	DATE	DESCRIPTION	APPROVED

New Mexico One Call, Inc. Call 2 days before you dig!
NMOC Dial 811 or 1-800-321-2537
 Professional Resources for Damage Prevention



Street Maintenance Program FY2018

WASHINGTON AVENUE MILL & INLAY PLAN

CITY OF ALAMOGORDO, NEW MEXICO, ENGINEERING DEPARTMENT

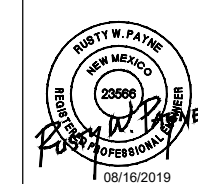

SMITH ENGINEERING
 Solutions for Today... Vision for Tomorrow
 201 N Church Street Suite 200A Las Cruces, NM 88001 Phone: 575-523-2395 www.smithengineering.pro

Public Works Bid No.: 2019-002
 Drawn By: MM Designed By: MM
 Checked By: RP Approved By: COA
 Scale: Horiz.: 1" = 40' Vert.: n/a
 HORIZ. BAR SCALE
 INCLUDE VERT SCALE ON P&P

Sheet No.: **RC2.0**
 Sheet 8 of 49
 EN1803

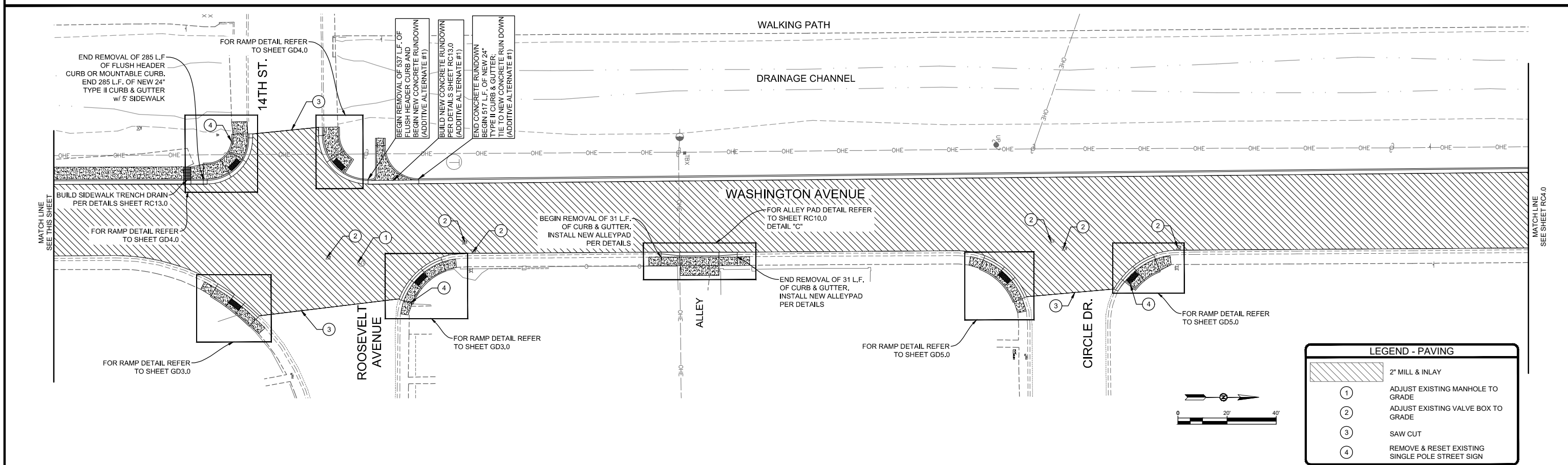
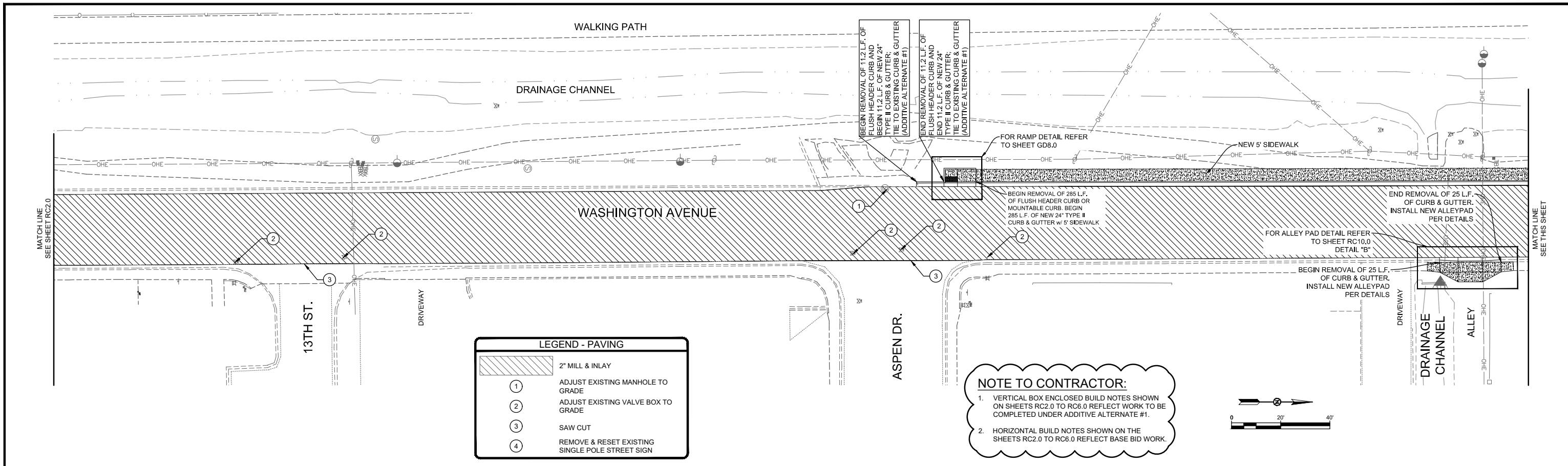

REV. No.	DATE	DESCRIPTION	APPROVED

New Mexico One Call, Inc. Call 2 days before you dig!
NMOC Dial 811 or 1-800-321-2537
 Professional Resources for Damage Prevention

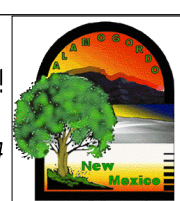

Street Maintenance Program FY2018

WASHINGTON AVENUE MILL & INLAY PLAN

CITY OF ALAMOGORDO, NEW MEXICO, ENGINEERING DEPARTMENT

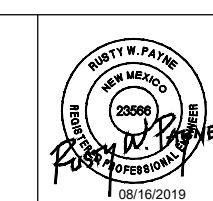

SMITH ENGINEERING
 Solutions for Today... Vision for Tomorrow
 201 N Church Street Suite 200A
 Las Cruces, NM 88001
 Phone: 575-523-2395
 www.smithengineering.pro

Public Works Bid No.: 2019-002	Sheet No.: RC3.0
Drawn By: MM	Designed By: MM
Checked By: RP	Approved By: COA
Scale: Horiz.: 1" = 40'	Vert.: n/a
HORIZ. BAR SCALE	
INCLUDE VERT SCALE ON P&P	
Sheet 9 of 49	EN1803

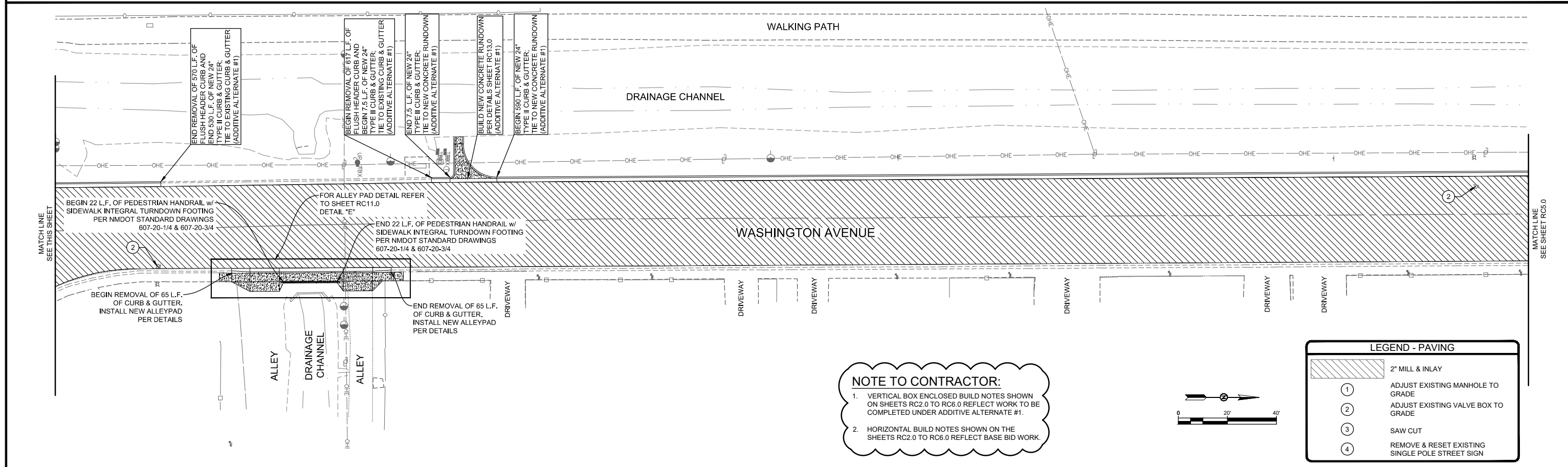
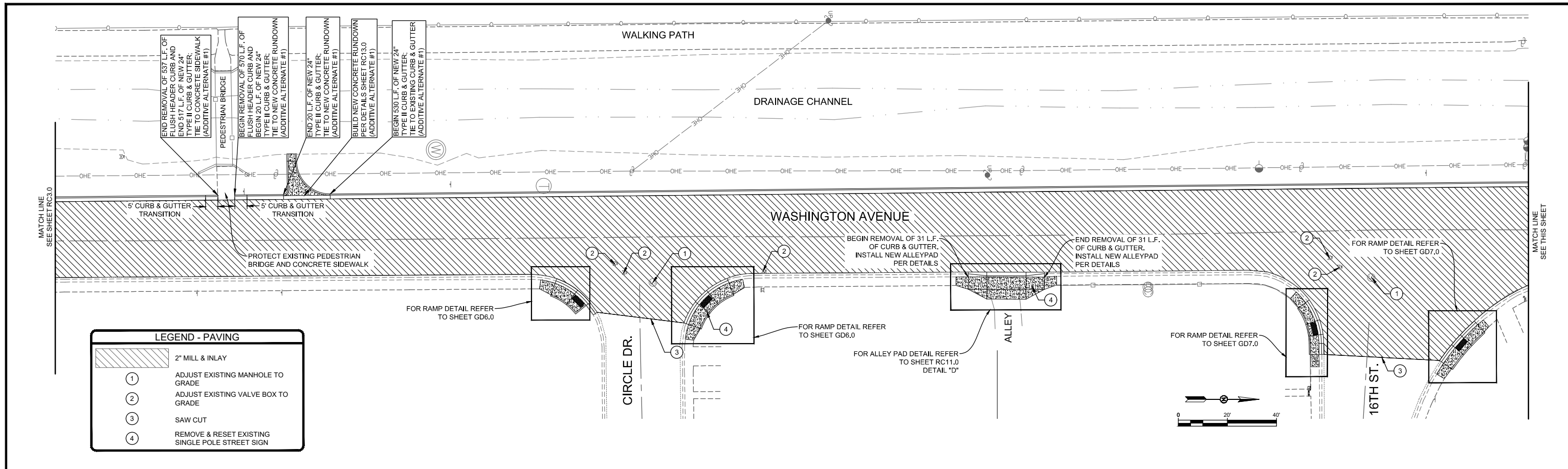

REV. No.	DATE	DESCRIPTION	APPROVED

New Mexico One Call, Inc. Call 2 days before you dig!
NMOC Dial 811 or 1-800-321-2537
 Professional Resources for Damage Prevention

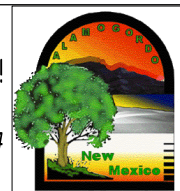

Street Maintenance Program FY2018

WASHINGTON AVENUE MILL & INLAY PLAN

CITY OF ALAMOGORDO, NEW MEXICO, ENGINEERING DEPARTMENT

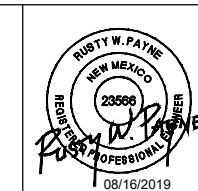

SMITH ENGINEERING
 Solutions for Today...
 Vision for Tomorrow
 201 N Church Street
 Suite 200A
 Las Cruces, NM 88001
 Phone: 575-523-2395
 www.smithengineering.pro

Public Works Bid No.: 2019-002	Sheet No.:
Drawn By: MM	Designed By: MM
Checked By: RP	Approved By: COA
Scale: Horiz.: 1" = 40'	Vert.: n/a
HORIZ. BAR SCALE	
INCLUDE VERT SCALE ON P&P	

RC4.0
Sheet 10 of 49
EN1803

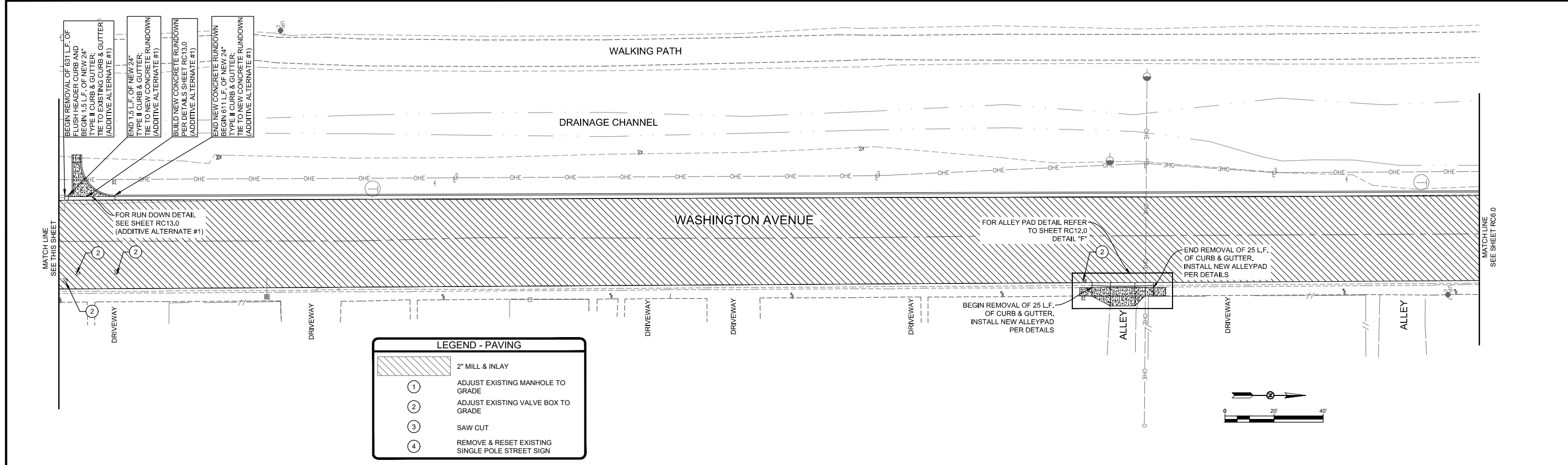
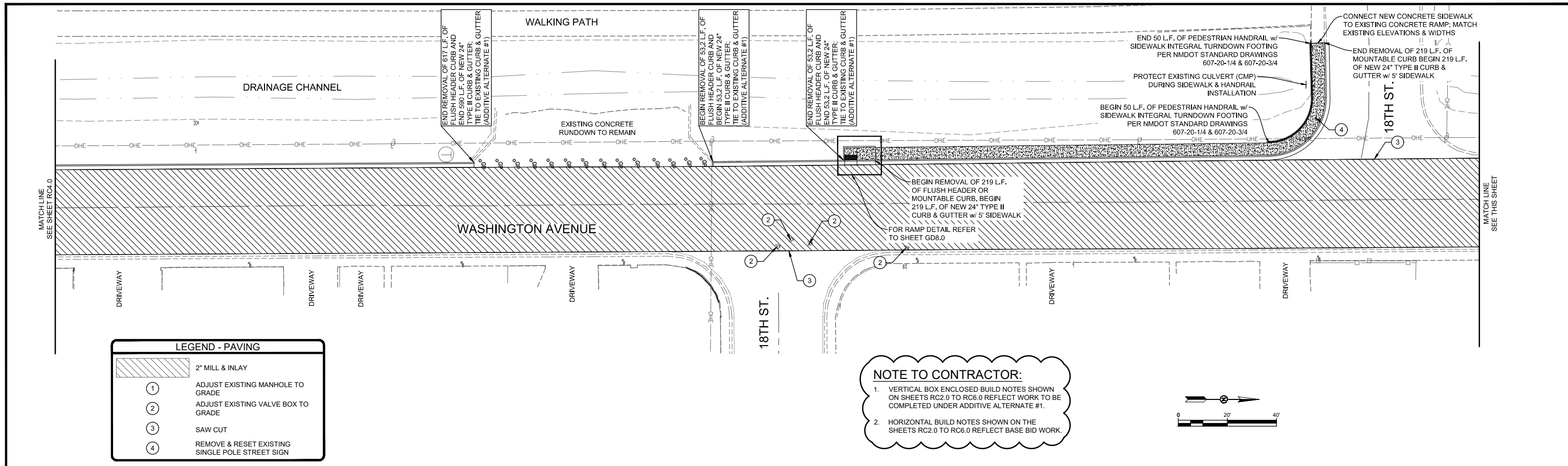

REV. No.	DATE	DESCRIPTION	APPROVED

New Mexico One Call, Inc. Call 2 days before you dig!
NMOC Dial 811 or 1-800-321-2537
 Professional Resources for Damage Prevention

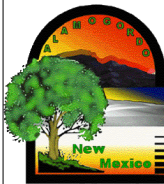

Street Maintenance Program FY2018

WASHINGTON AVENUE MILL & INLAY PLAN

CITY OF ALAMOGORDO, NEW MEXICO, ENGINEERING DEPARTMENT

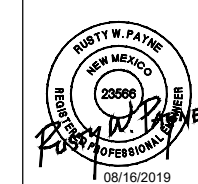

SMITH ENGINEERING
 Solutions for Today... Vision for Tomorrow
 201 N Church Street Suite 200A
 Las Cruces, NM 88001
 Phone: 575-523-2395
 www.smithengineering.pro

Public Works Bid No.: 2019-002
 Drawn By: MM Designed By: MM
 Checked By: RP Approved By: COA
 Scale: Horiz.: 1" = 40' Vert.: n/a
 HORIZ. BAR SCALE
 INCLUDE VERT SCALE ON P&P

Sheet No.: **RC5.0**
 Sheet 11 of 49
 EN1803

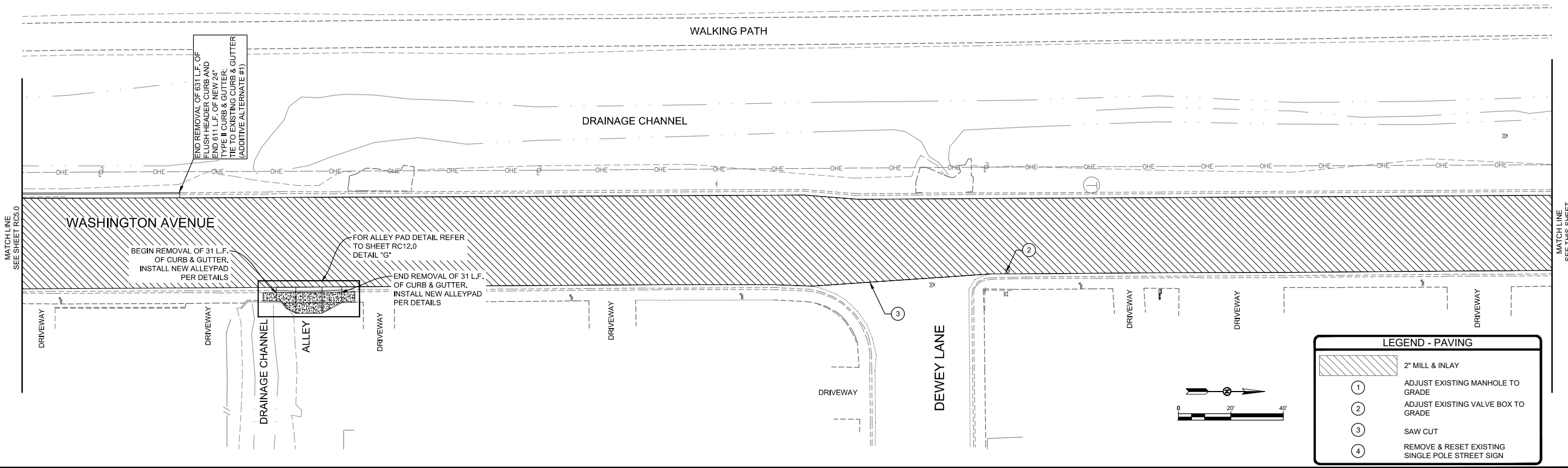

LEGEND - PAVING

	2" MILL & INLAY
1	ADJUST EXISTING MANHOLE TO GRADE
2	ADJUST EXISTING VALVE BOX TO GRADE
3	SAW CUT
4	REMOVE & RESET EXISTING SINGLE POLE STREET SIGN

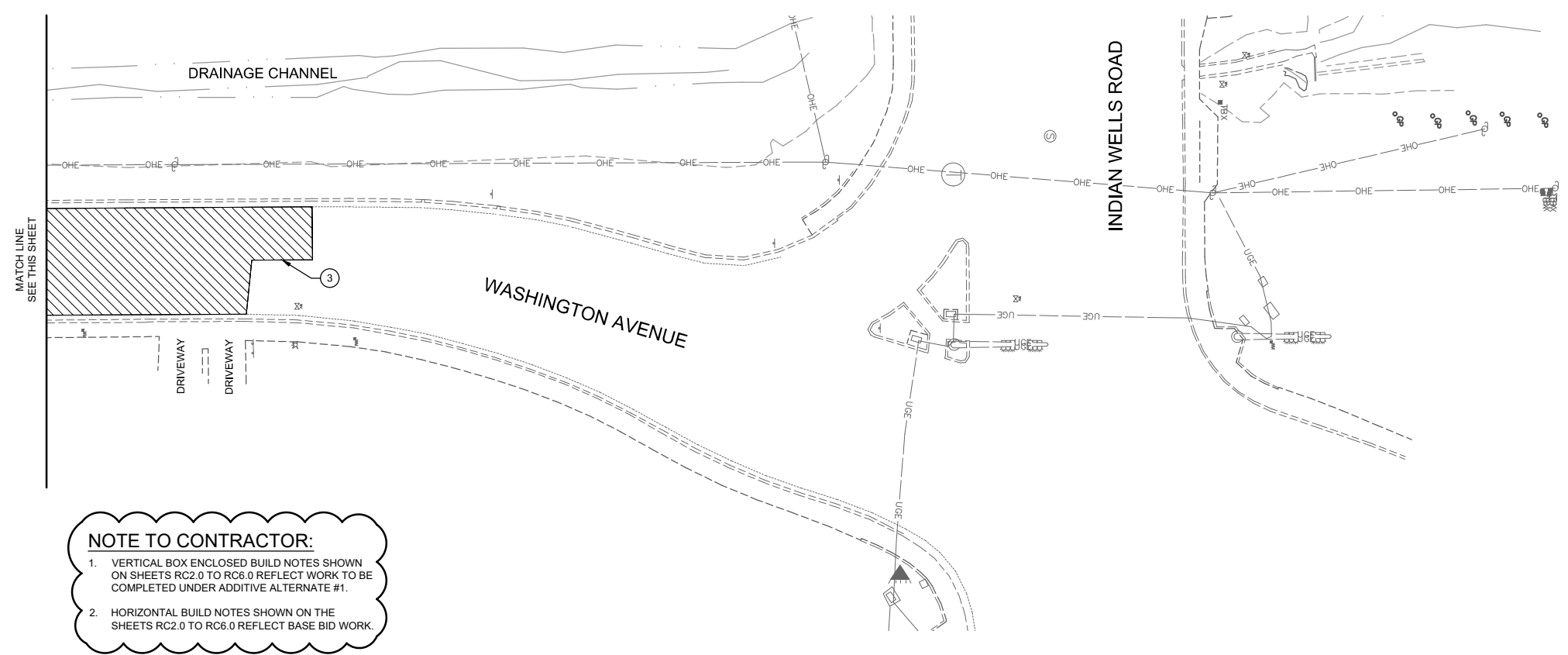
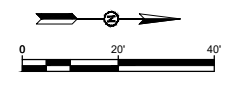

NOTE TO CONTRACTOR:

1. VERTICAL BOX ENCLOSED BUILD NOTES SHOWN ON SHEETS RC2.0 TO RC6.0 REFLECT WORK TO BE COMPLETED UNDER ADDITIVE ALTERNATE #1.
2. HORIZONTAL BUILD NOTES SHOWN ON THE SHEETS RC2.0 TO RC6.0 REFLECT BASE BID WORK.

LEGEND - PAVING

	2" MILL & INLAY
1	ADJUST EXISTING MANHOLE TO GRADE
2	ADJUST EXISTING VALVE BOX TO GRADE
3	SAW CUT
4	REMOVE & RESET EXISTING SINGLE POLE STREET SIGN

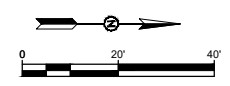

REV. No.	DATE	DESCRIPTION	APPROVED

New Mexico One Call, Inc. Call 2 days before you dig!
NMOC Dial 811 or 1-800-321-2537
 Professional Resources for Damage Prevention

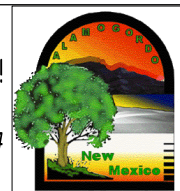

Street Maintenance Program FY2018

WASHINGTON AVENUE MILL & INLAY PLAN
 CITY OF ALAMOGORDO, NEW MEXICO, ENGINEERING DEPARTMENT

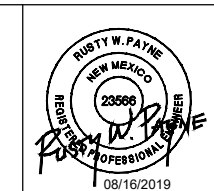

SMITH ENGINEERING
 Solutions for Today... Vision for Tomorrow
 201 N Church Street Suite 200A Las Cruces, NM 88001 Phone: 575-523-2395 www.smithengineering.pro

Public Works Bid No.: 2019-002
 Drawn By: MM Designed By: MM
 Checked By: RP Approved By: COA
 Scale: Horiz.: 1" = 40' Vert.: n/a
 HORIZ. BAR SCALE
 INCLUDE VERT SCALE ON P&P

Sheet No.: **RC6.0**
 Sheet 12 of 49
 EN1803

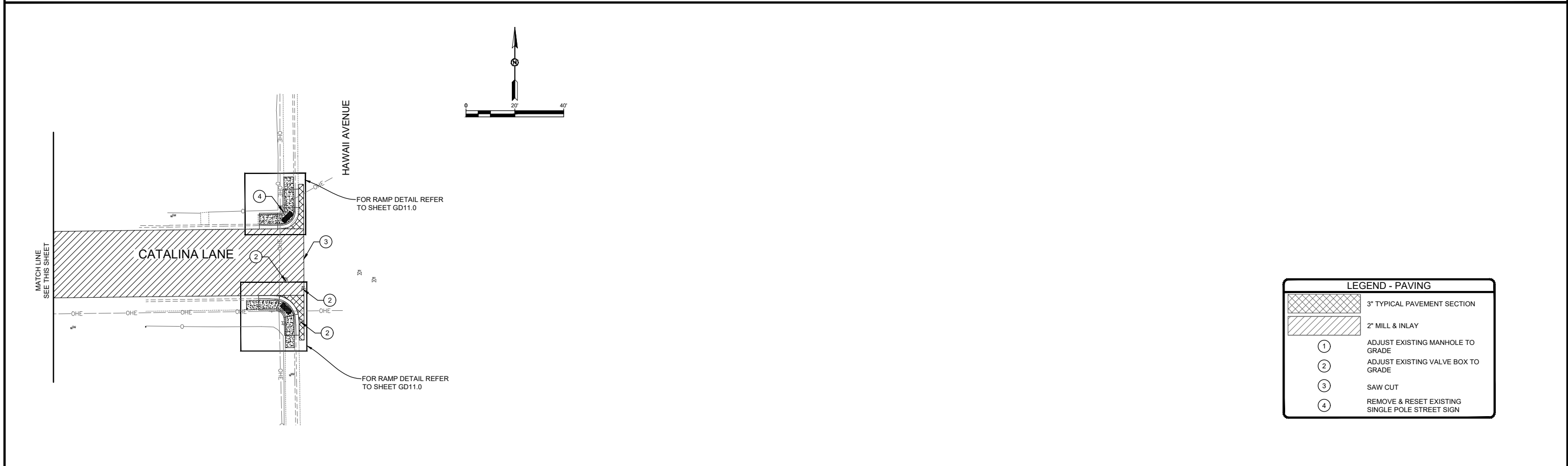
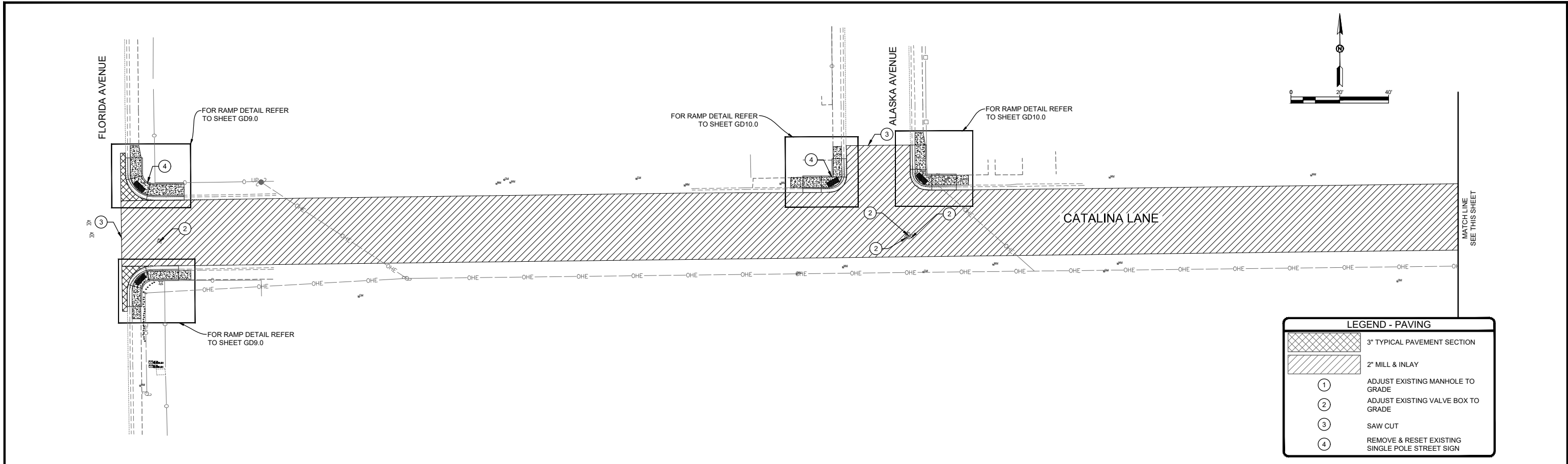

REV. No.	DATE	DESCRIPTION	APPROVED

New Mexico One Call, Inc. Call 2 days before you dig!
NMOC Dial 811 or 1-800-321-2537
 Professional Resources for Damage Prevention

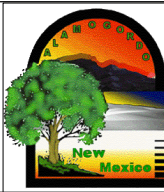

Street Maintenance Program FY2018

CATALINA LANE MILL & INLAY PLAN

CITY OF ALAMOGORDO, NEW MEXICO, ENGINEERING DEPARTMENT

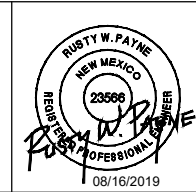

SMITH ENGINEERING
 Solutions for Today...
 Vision for Tomorrow
 201 N Church Street
 Suite 200A
 Las Cruces, NM 88001
 Phone: 575-523-2395
 www.smithengineering.pro

Public Works Bid No.: 2019-002
 Drawn By: MM Designed By: MM
 Checked By: RP Approved By: COA
 Scale: Horiz.: 1" = 40' Vert.: n/a
 HORIZ. BAR SCALE
 INCLUDE VERT SCALE ON P&P

Sheet No.: **RC7.0**
 Sheet 13 of 49
 EN1803

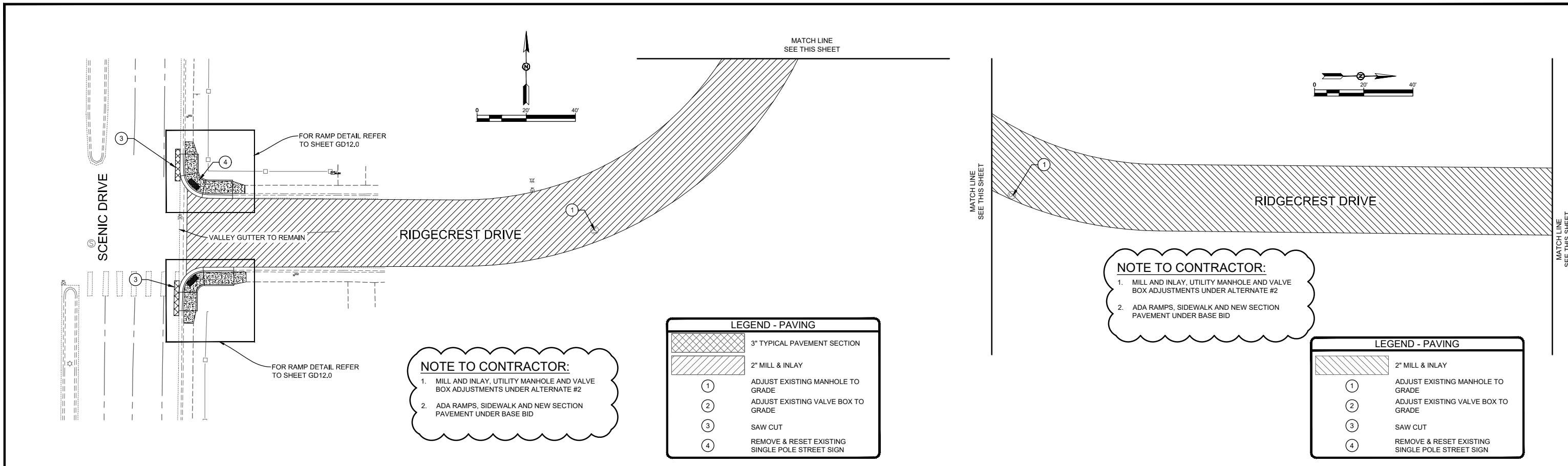

NOTE TO CONTRACTOR:

- MILL AND INLAY, UTILITY MANHOLE AND VALVE BOX ADJUSTMENTS UNDER ALTERNATE #2
- ADA RAMPS, SIDEWALK AND NEW SECTION PAVEMENT UNDER BASE BID

LEGEND - PAVING	
	3" TYPICAL PAVEMENT SECTION
	2" MILL & INLAY
①	ADJUST EXISTING MANHOLE TO GRADE
②	ADJUST EXISTING VALVE BOX TO GRADE
③	SAW CUT
④	REMOVE & RESET EXISTING SINGLE POLE STREET SIGN

NOTE TO CONTRACTOR:

- MILL AND INLAY, UTILITY MANHOLE AND VALVE BOX ADJUSTMENTS UNDER ALTERNATE #2
- ADA RAMPS, SIDEWALK AND NEW SECTION PAVEMENT UNDER BASE BID

LEGEND - PAVING	
	2" MILL & INLAY
①	ADJUST EXISTING MANHOLE TO GRADE
②	ADJUST EXISTING VALVE BOX TO GRADE
③	SAW CUT
④	REMOVE & RESET EXISTING SINGLE POLE STREET SIGN

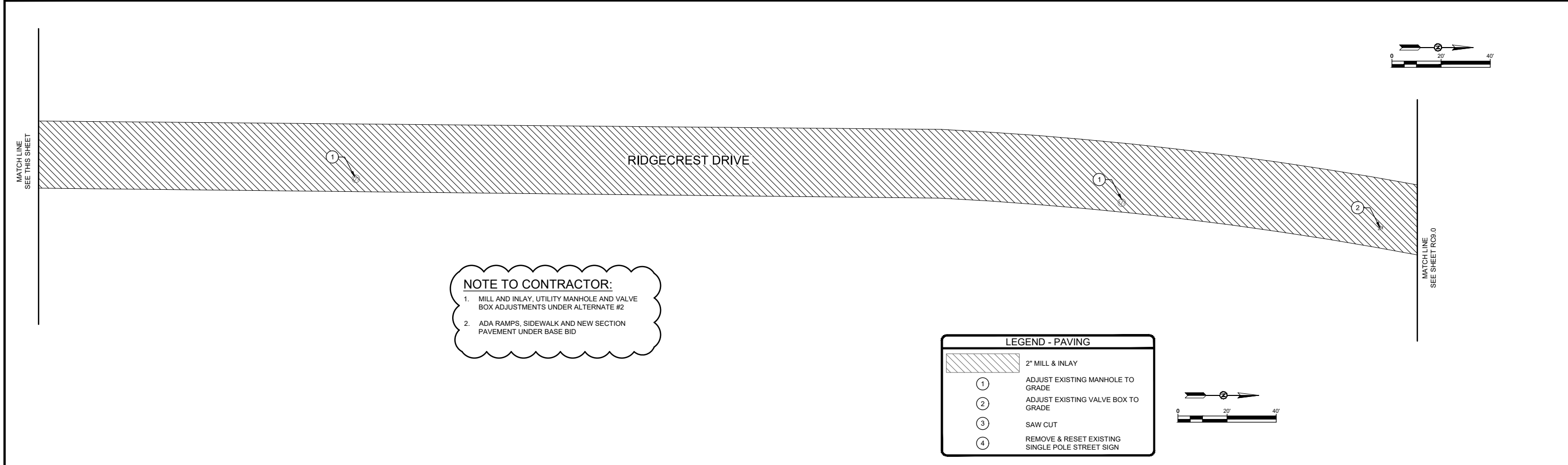

NOTE TO CONTRACTOR:

- MILL AND INLAY, UTILITY MANHOLE AND VALVE BOX ADJUSTMENTS UNDER ALTERNATE #2
- ADA RAMPS, SIDEWALK AND NEW SECTION PAVEMENT UNDER BASE BID

LEGEND - PAVING	
	2" MILL & INLAY
①	ADJUST EXISTING MANHOLE TO GRADE
②	ADJUST EXISTING VALVE BOX TO GRADE
③	SAW CUT
④	REMOVE & RESET EXISTING SINGLE POLE STREET SIGN

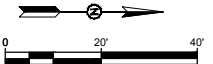

REV. No.	DATE	DESCRIPTION	APPROVED

New Mexico One Call, Inc. Call 2 days before you dig!
NMOC Dial 811 or 1-800-321-2537
 Professional Resources for Damage Prevention

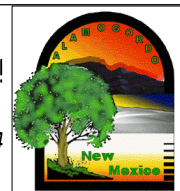

Street Maintenance Program FY2018

RIDGECREST DRIVE PLAN

CITY OF ALAMOGORDO, NEW MEXICO, ENGINEERING DEPARTMENT

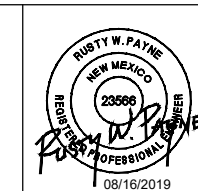

SMITH ENGINEERING
 Solutions for Today...
 Vision for Tomorrow
 201 N Church Street
 Suite 200A
 Las Cruces, NM 88001
 Phone: 575-523-2395
 www.smithengineering.pro

Public Works Bid No.: 2019-002	Sheet No.:
Drawn By: MM Designed By: MM	RC8.0
Checked By: RP Approved By: COA	Sheet 14 of 49
Scale: Horiz.: 1" = 40' Vert.: n/a	EN1803
HORIZ. BAR SCALE	
INCLUDE VERT SCALE ON P&P	

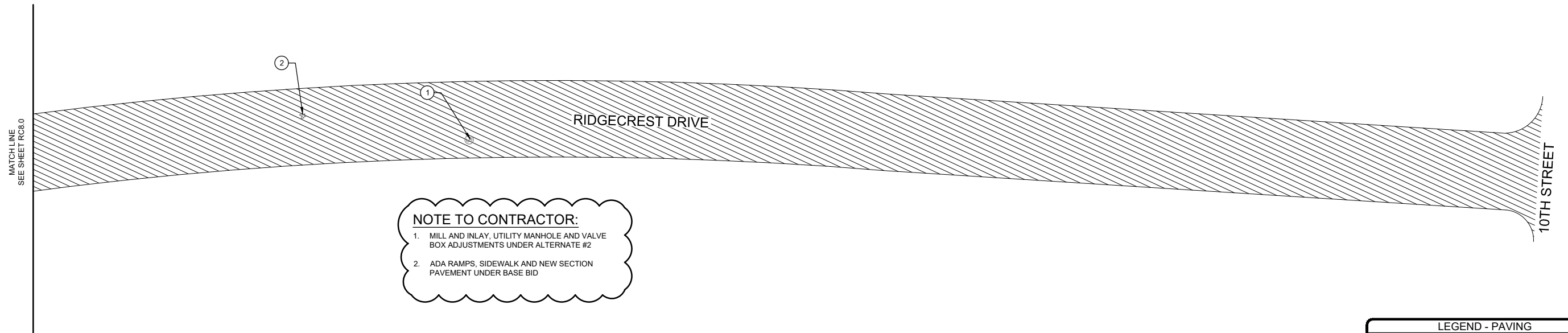

NOTE TO CONTRACTOR:

1. MILL AND INLAY, UTILITY MANHOLE AND VALVE BOX ADJUSTMENTS UNDER ALTERNATE #2
2. ADA RAMP, SIDEWALK AND NEW SECTION PAVEMENT UNDER BASE BID

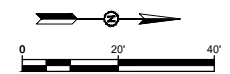

LEGEND - PAVING	
	2" MILL & INLAY
①	ADJUST EXISTING MANHOLE TO GRADE
②	ADJUST EXISTING VALVE BOX TO GRADE
③	SAW CUT
④	REMOVE & RESET EXISTING SINGLE POLE STREET SIGN

REV. No.	DATE	DESCRIPTION	APPROVED

New Mexico One Call, Inc. Call 2 days before you dig!
NMOC Dial 811 or 1-800-321-2537
 Professional Resources for Damage Prevention



Street Maintenance Program FY2018

RIDGECREST DRIVE PLAN

CITY OF ALAMOGORDO, NEW MEXICO, ENGINEERING DEPARTMENT

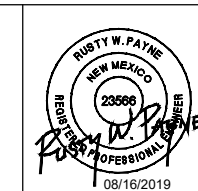

SMITH ENGINEERING

Solutions for Today...
 Vision for Tomorrow
 201 N Church Street
 Suite 200A
 Las Cruces, NM 88001
 Phone: 575-523-2395
 www.smithengineering.pro

Public Works Bid No.: 2019-002
Drawn By: MM Designed By: MM
Checked By: RP Approved By: COA
Scale: Horiz.: 1" = 40' Vert.: n/a
HORIZ. BAR SCALE
INCLUDE VERT SCALE ON P&P

Sheet No.:	RC9.0
Sheet 15 of 49	EN1803

ALLEY PAD GENERAL NOTES:

1. USE 3/4" EXPANSION BOARD WHERE SIDEWALK OR DRIVE/ALLEY PADS ABUTS BUILDINGS, FENCES, WALLS, SIDEWALKS, OR OTHER IMMOVABLE OBJECTS.
2. IF AREA BEHIND DRIVE/ALLEY PAD IS HIGHER, THE TRANSITION AREA CAN HAVE A MAXIMUM SLOPE OF 8:1 OR FLATTER TO MATCH EXISTING GRADE.
3. IF AREA BEHIND DRIVE/ALLEY PAD IS LOWER, THE TRANSITION AREA CAN HAVE A 12:1 OR FLATTER SLOPE TO MATCH EXISTING GRADE.
4. DRIVE/ALLEY PADS WIDER THAN 18' (NOMINAL) ARE TO HAVE EXPANSION BOARD JOINT AT MIDPOINT. DRIVE/ALLEY PADS WIDER THAN 22' ARE TO HAVE EXPANSION BOARD JOINTS EQUALLY SPACED WITH NO MORE THAN 20' BETWEEN JOINTS. CONSTRUCTION JOINTS ARE TO BE MADE NOT EXCEEDING 5' INTERVALS AND MATCHING CONSTRUCTION JOINTS ON CURBING WHEREVER POSSIBLE.
5. PAYMENT FOR SUBGRADE PREPARATION UNDER SIDEWALKS, DRIVE/ALLEY PADS, AND CURB & GUTTER SHALL BE CONSIDERED INCIDENTAL TO RESPECTIVE ITEMS.
6. SIDEWALK AND DRIVE/ALLEY PADS MAY BE PLACED AT THE SAME TIME.
7. DRIVE/ALLEY PADS, RAMPS, AND TRANSITION AREAS SHALL BE PAID AS 6-INCH THICK CONCRETE. SIDEWALK TRANSITION AREAS SHALL BE PAID AS 4-INCH THICK CONCRETE.

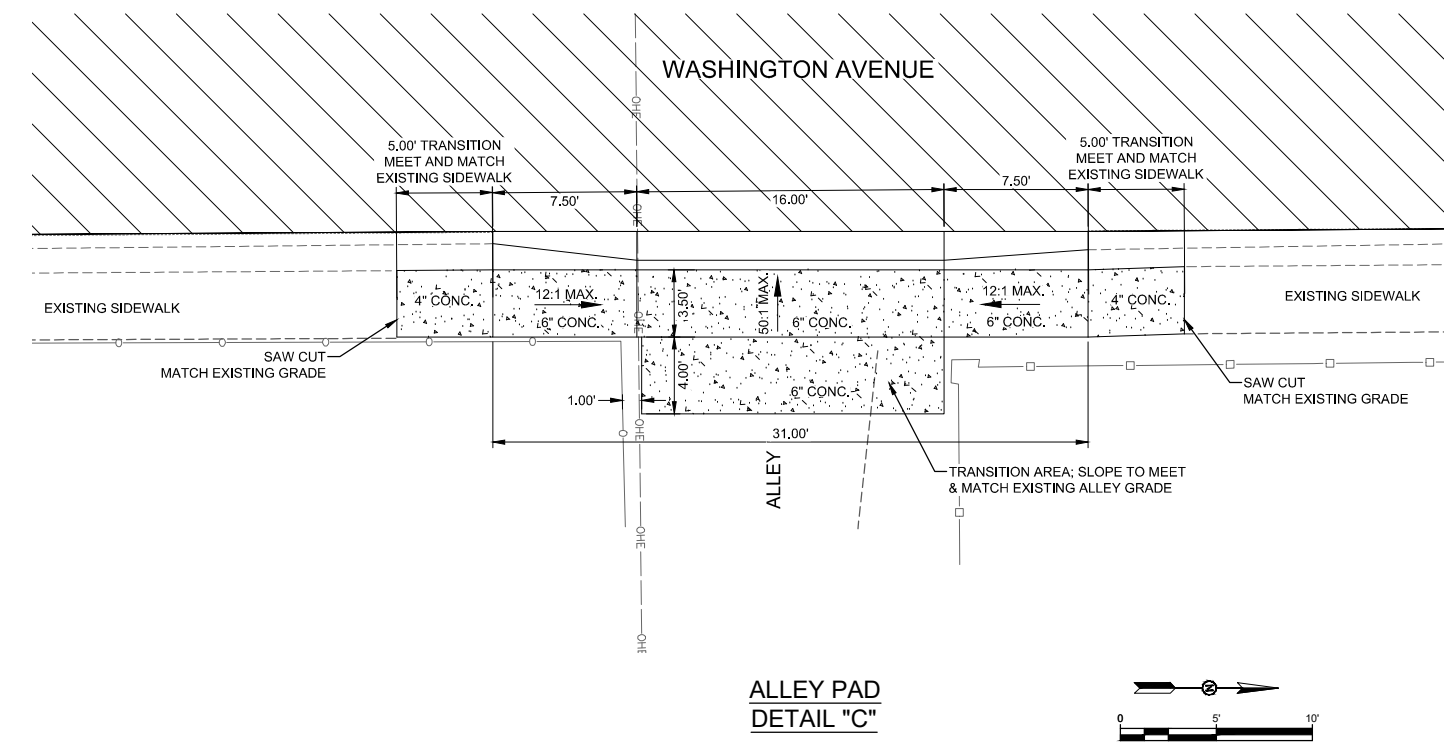
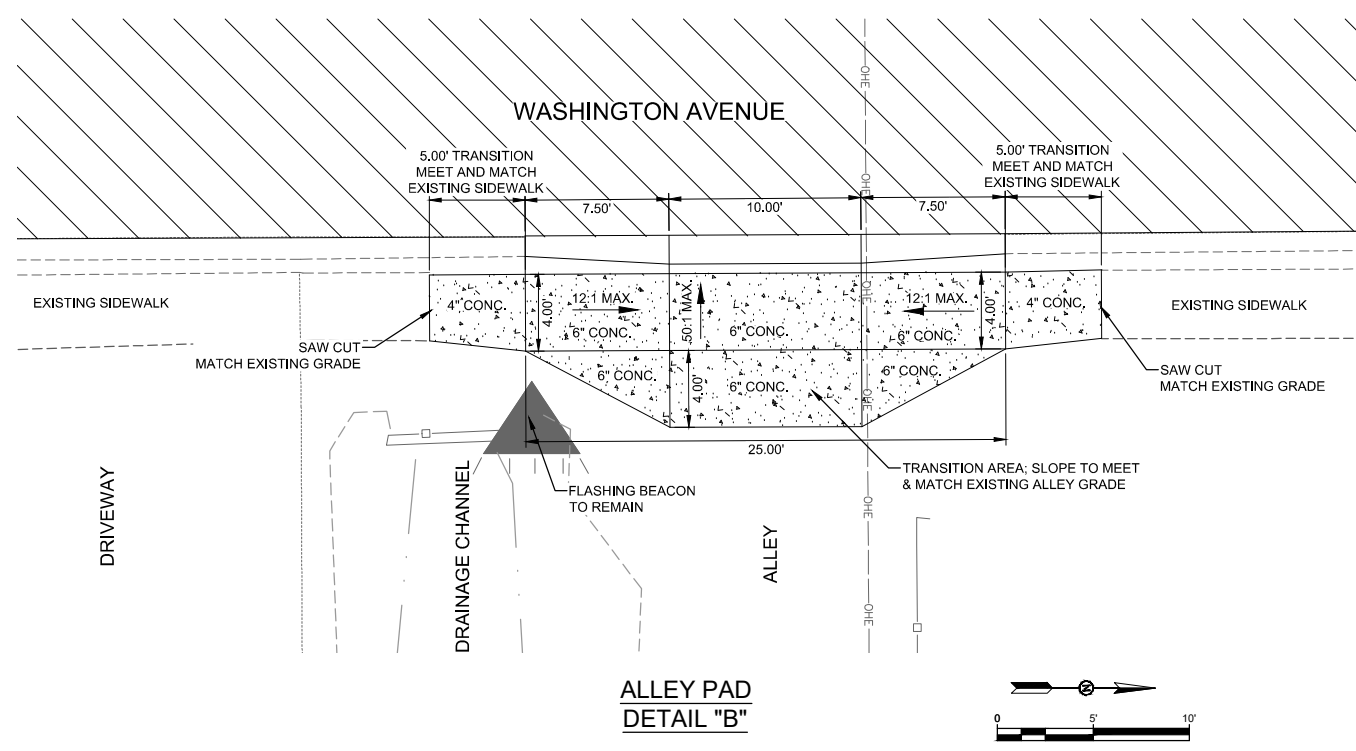
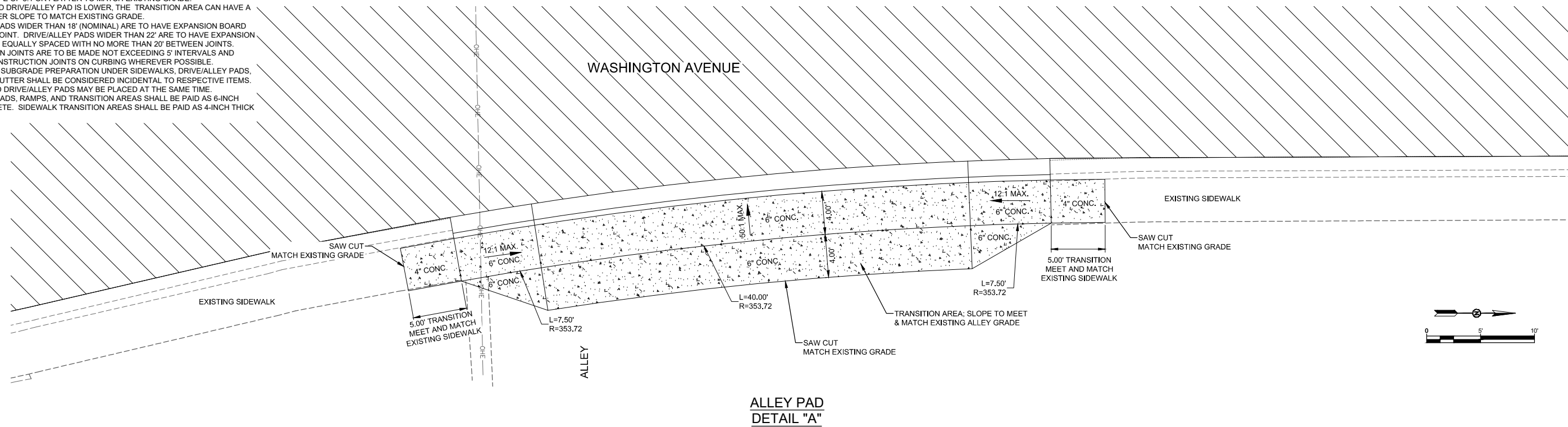

REV. No.	DATE	DESCRIPTION	APPROVED

New Mexico One Call, Inc. Call 2 days before you dig!
NMOC Dial 811 or 1-800-321-2537
 Professional Resources for Damage Prevention



Street Maintenance Program FY2018
ALLEY PAD DETAILS
 CITY OF ALAMOGORDO, NEW MEXICO, ENGINEERING DEPARTMENT

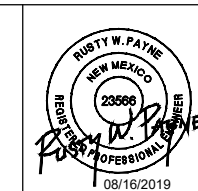

SMITH ENGINEERING
 Solutions for Today... Vision for Tomorrow
 201 N Church Street Suite 200A
 Las Cruces, NM 88001
 Phone: 575-523-2395
 www.smithengineering.pro

Public Works Bid No.: 2019-002
 Drawn By: MM Designed By: MM
 Checked By: RP Approved By: COA
 Scale: Horiz.: 1" = 10' Vert.: n/a
 HORIZ. BAR SCALE
 INCLUDE VERT SCALE ON P&P

Sheet No.: **RC10.0**
 Sheet 16 of 49
 EN1803

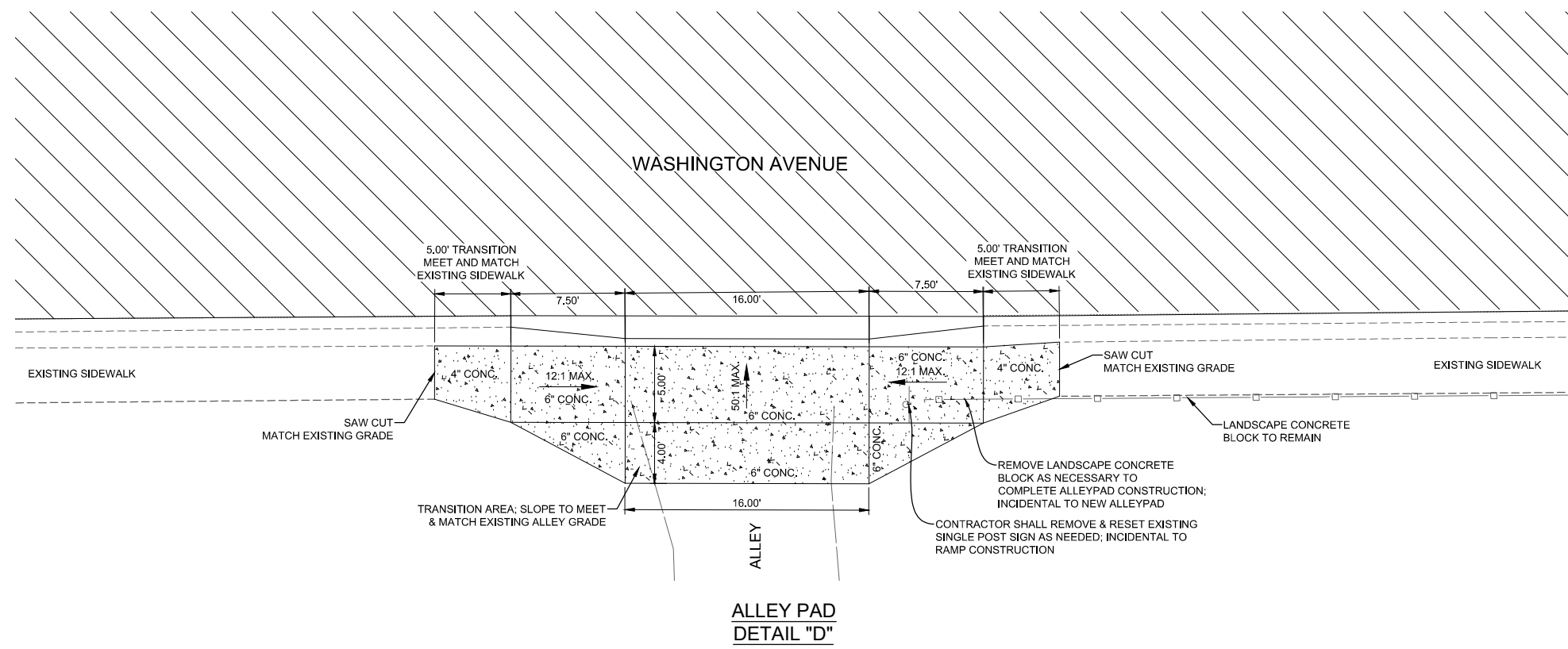

ALLEY PAD
DETAIL "D"

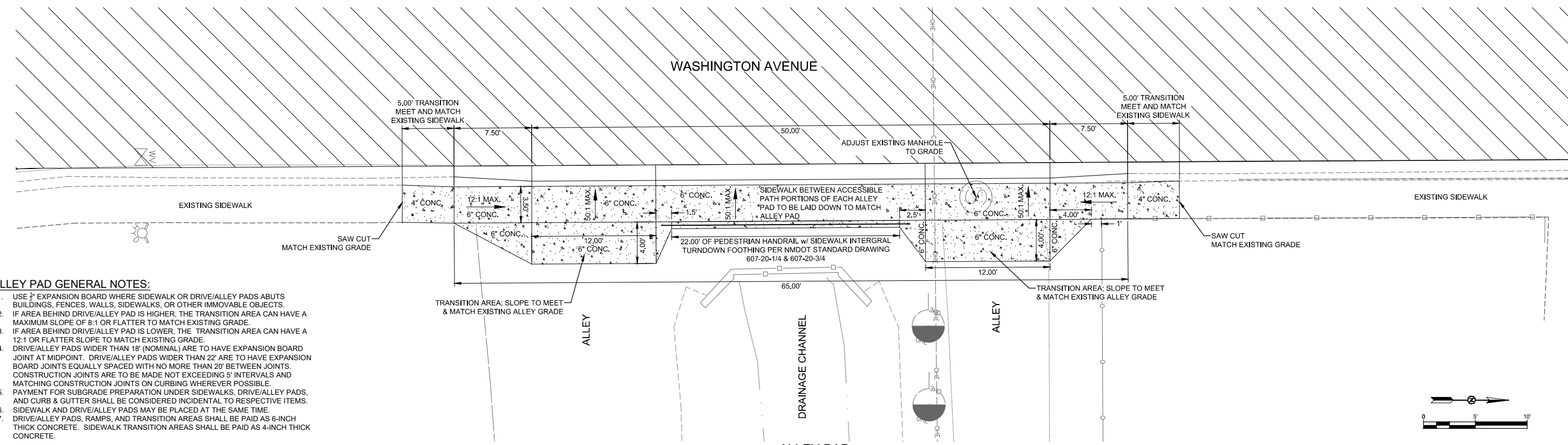

ALLEY PAD
DETAIL "E"

ALLEY PAD GENERAL NOTES:

1. USE 3/4" EXPANSION BOARD WHERE SIDEWALK OR DRIVE/ALLEY PADS ABUTS BUILDINGS, FENCES, WALLS, SIDEWALKS, OR OTHER IMMOVABLE OBJECTS.
2. IF AREA BEHIND DRIVE/ALLEY PAD IS HIGHER, THE TRANSITION AREA CAN HAVE A MAXIMUM SLOPE OF 8:1 OR FLATTER TO MATCH EXISTING GRADE.
3. IF AREA BEHIND DRIVE/ALLEY PAD IS LOWER, THE TRANSITION AREA CAN HAVE A 12:1 OR FLATTER SLOPE TO MATCH EXISTING GRADE.
4. DRIVE/ALLEY PADS WIDER THAN 18' (NOMINAL) ARE TO HAVE EXPANSION BOARD JOINT AT MIDPOINT. DRIVE/ALLEY PADS WIDER THAN 22' ARE TO HAVE EXPANSION BOARD JOINTS EQUALLY SPACED WITH NO MORE THAN 20' BETWEEN JOINTS. CONSTRUCTION JOINTS ARE TO BE MADE NOT EXCEEDING 5" INTERVALS AND MATCHING CONSTRUCTION JOINTS ON CURBING WHEREVER POSSIBLE.
5. PAYMENT FOR SUBGRADE PREPARATION UNDER SIDEWALKS, DRIVE/ALLEY PADS, AND CURB & GUTTER SHALL BE CONSIDERED INCIDENTAL TO RESPECTIVE ITEMS.
6. SIDEWALK AND DRIVE/ALLEY PADS MAY BE PLACED AT THE SAME TIME.
7. DRIVE/ALLEY PADS, RAMPS, AND TRANSITION AREAS SHALL BE PAID AS 6-INCH THICK CONCRETE. SIDEWALK TRANSITION AREAS SHALL BE PAID AS 4-INCH THICK CONCRETE.

REV. No.	DATE	DESCRIPTION	APPROVED

New Mexico One Call, Inc. Call 2 days before you dig!
NMOC Dial 811 or 1-800-321-2537
 Professional Resources for Damage Prevention

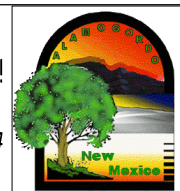

Street Maintenance Program FY2018
ALLEY PAD DETAILS
 CITY OF ALAMOGORDO, NEW MEXICO, ENGINEERING DEPARTMENT

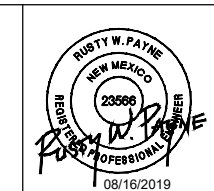

SMITH ENGINEERING
 Solutions for Today... Vision for Tomorrow
 201 N Church Street Suite 200A Las Cruces, NM 88001 Phone: 575-523-2395 www.smithengineering.pro

Public Works Bid No.: 2019-002	Sheet No.: RC11.0
Drawn By: MM	Designed By: MM
Checked By: RP	Approved By: COA
Scale: Horiz.: 1" = 10'	Vert.: n/a
HORIZ. BAR SCALE	
INCLUDE VERT SCALE ON P&P	

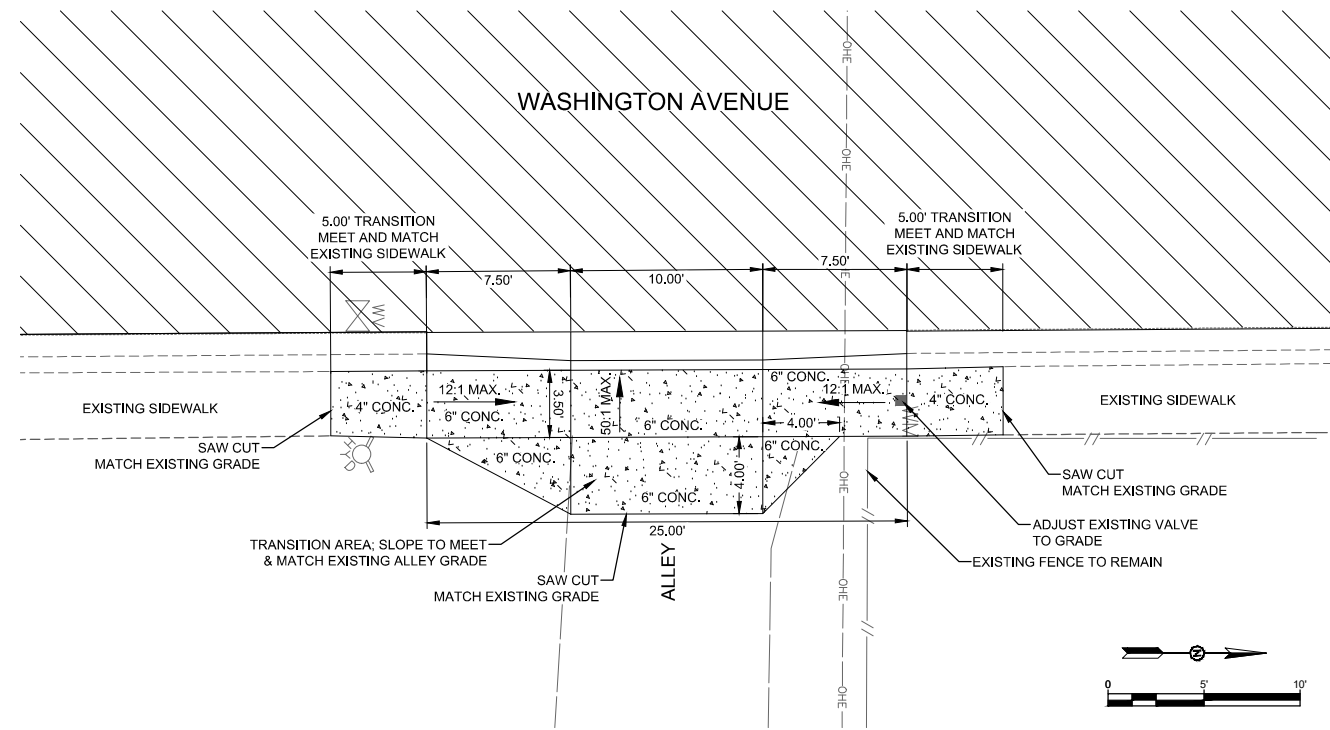

ALLEY PAD
DETAIL "F"

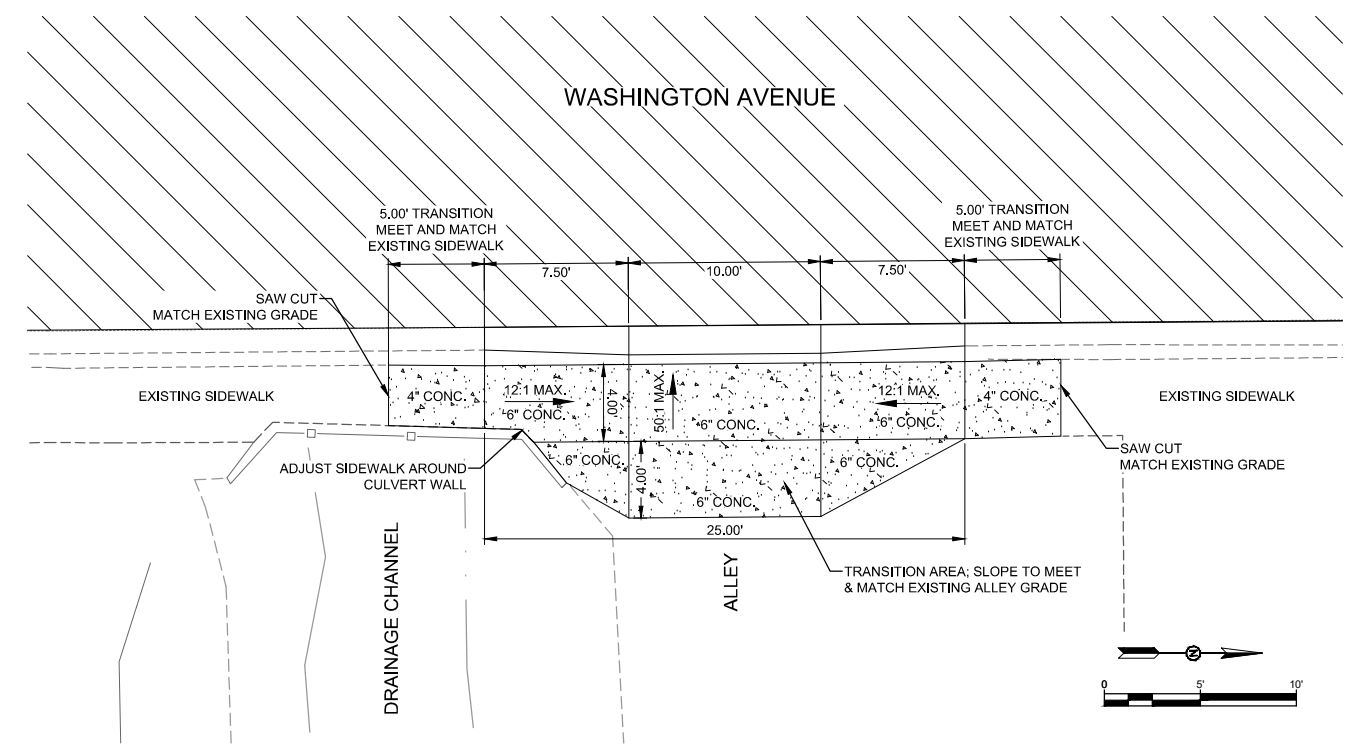

ALLEY PAD
DETAIL "G"

- ALLEY PAD GENERAL NOTES:**
1. USE 1/2" EXPANSION BOARD WHERE SIDEWALK OR DRIVE/ALLEY PADS ABUTS BUILDINGS, FENCES, WALLS, SIDEWALKS, OR OTHER IMMOVABLE OBJECTS.
 2. IF AREA BEHIND DRIVE/ALLEY PAD IS HIGHER, THE TRANSITION AREA CAN HAVE A MAXIMUM SLOPE OF 8:1 OR FLATTER TO MATCH EXISTING GRADE.
 3. IF AREA BEHIND DRIVE/ALLEY PAD IS LOWER, THE TRANSITION AREA CAN HAVE A 12:1 OR FLATTER SLOPE TO MATCH EXISTING GRADE.
 4. DRIVE/ALLEY PADS WIDER THAN 18' (NOMINAL) ARE TO HAVE EXPANSION BOARD JOINT AT MIDPOINT. DRIVE/ALLEY PADS WIDER THAN 22' ARE TO HAVE EXPANSION BOARD JOINTS EQUALLY SPACED WITH NO MORE THAN 20' BETWEEN JOINTS. CONSTRUCTION JOINTS ARE TO BE MADE NOT EXCEEDING 5' INTERVALS AND MATCHING CONSTRUCTION JOINTS ON CURBING WHEREVER POSSIBLE.
 5. PAYMENT FOR SUBGRADE PREPARATION UNDER SIDEWALKS, DRIVE/ALLEY PADS, AND CURB & GUTTER SHALL BE CONSIDERED INCIDENTAL TO RESPECTIVE ITEMS.
 6. SIDEWALK AND DRIVE/ALLEY PADS MAY BE PLACED AT THE SAME TIME.
 7. DRIVE/ALLEY PADS, RAMPS, AND TRANSITION AREAS SHALL BE PAID AS 6-INCH THICK CONCRETE. SIDEWALK TRANSITION AREAS SHALL BE PAID AS 4-INCH THICK CONCRETE.

REV. No.	DATE	DESCRIPTION	APPROVED

New Mexico One Call, Inc. Call 2 days before you dig!
NMOC Dial 811 or 1-800-321-2537
 Professional Resources for Damage Prevention

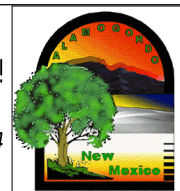

Street Maintenance Program FY2018

ALLEY PAD DETAILS

CITY OF ALAMOGORDO, NEW MEXICO, ENGINEERING DEPARTMENT

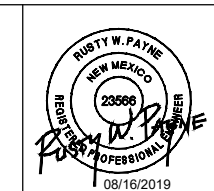

SMITH ENGINEERING
 Solutions for Today... Vision for Tomorrow
 201 N Church Street
 Suite 200A
 Las Cruces, NM 88001
 Phone: 575-523-2395
 www.smithengineering.pro

Public Works Bid No.: 2019-002	Drawn By: MM	Designed By: MM
Checked By: RP	Approved By: COA	Scale: Horiz.: 1" = 10' Vert.: n/a
HORIZ. BAR SCALE INCLUDE VERT SCALE ON P&P		

Sheet No.: RC12.0
Sheet 18 of 49
EN1803

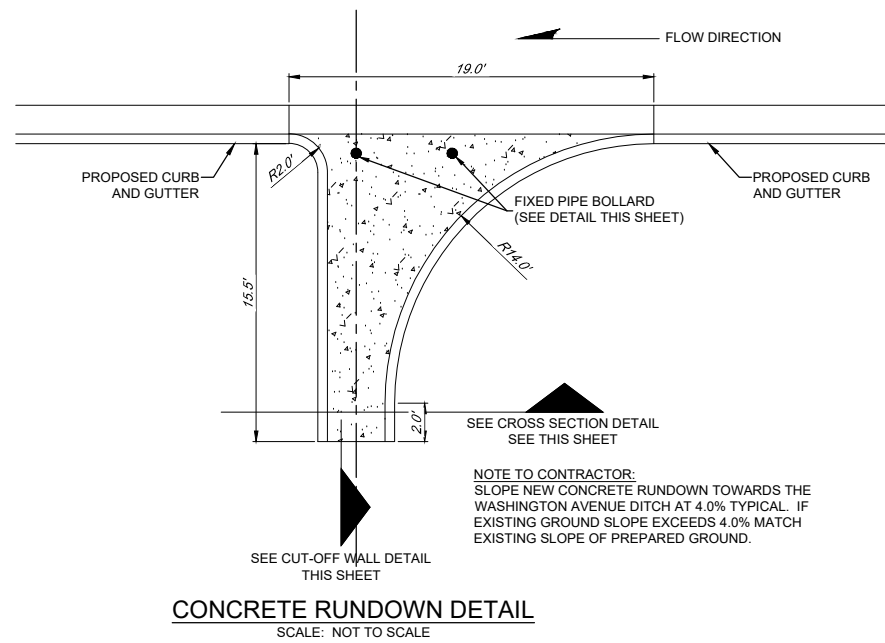

CONCRETE RUNDOWN DETAIL
SCALE: NOT TO SCALE

NOTE TO CONTRACTOR:
SLOPE NEW CONCRETE RUNDOWN TOWARDS THE WASHINGTON AVENUE DITCH AT 4.0% TYPICAL. IF EXISTING GROUND SLOPE EXCEEDS 4.0% MATCH EXISTING SLOPE OF PREPARED GROUND.

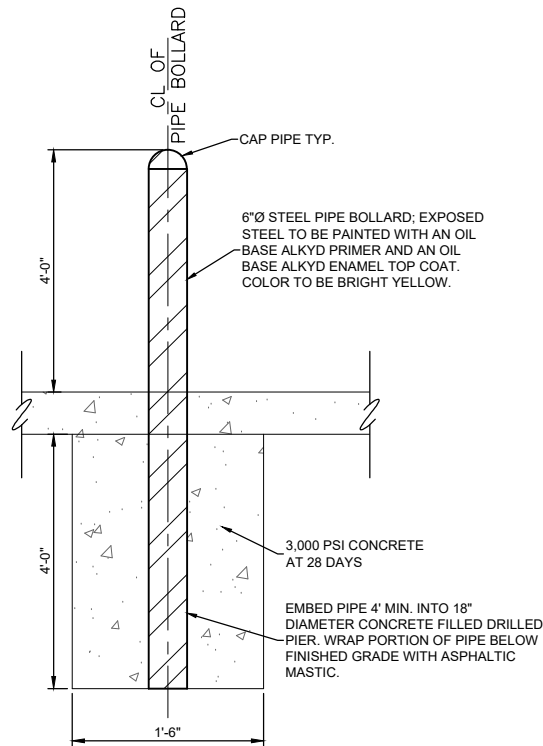

FIXED PIPE BOLLARD
SCALE: NOT TO SCALE

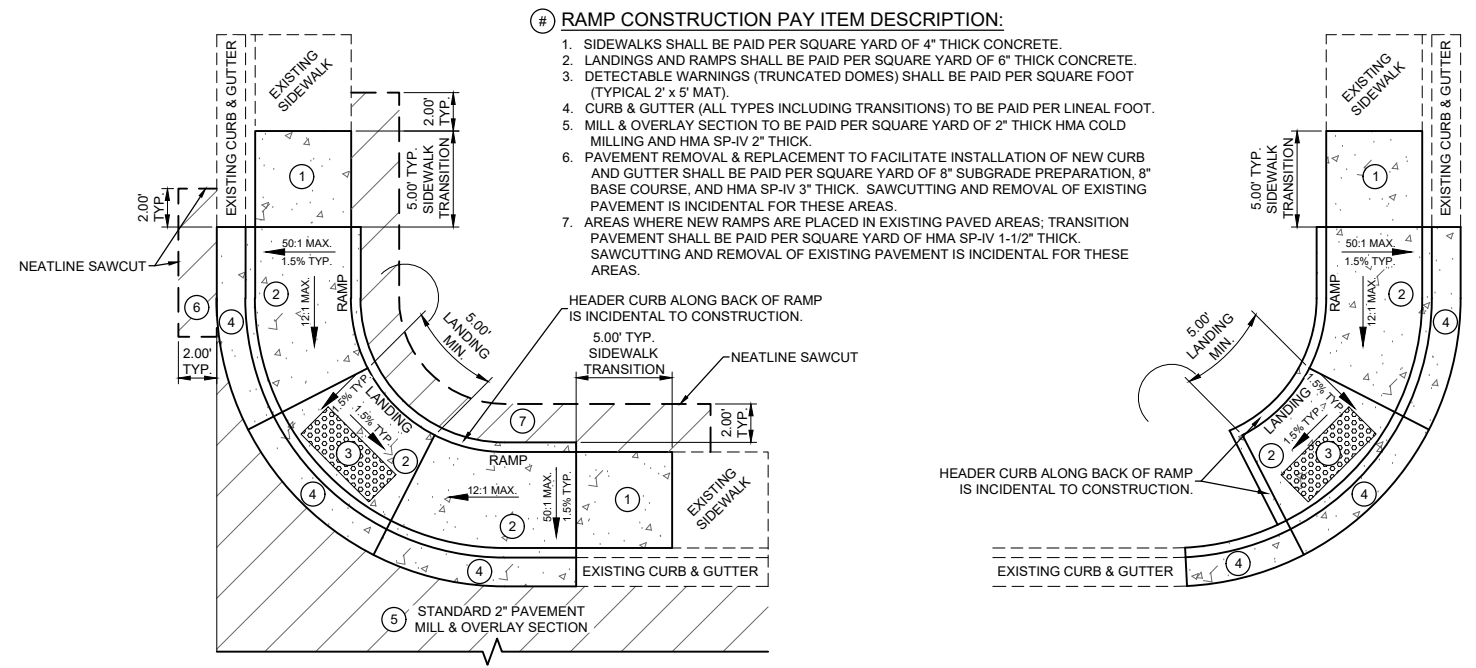

TYPICAL RAMP PAY ITEM DESCRIPTION
SCALE: NOT TO SCALE

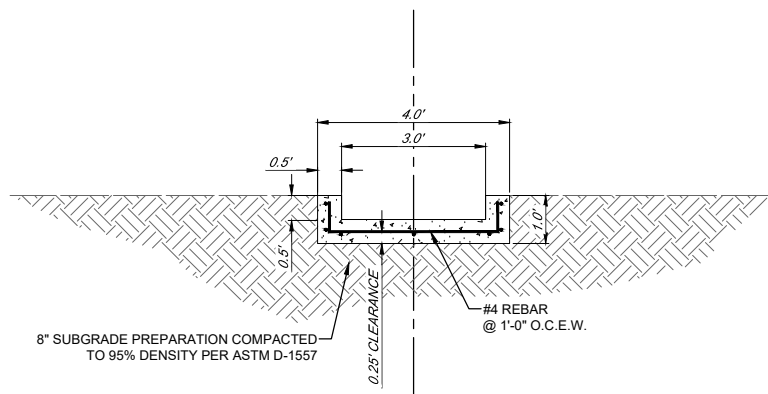

RUNDOWN CROSS SECTION DETAIL
SCALE: NOT TO SCALE

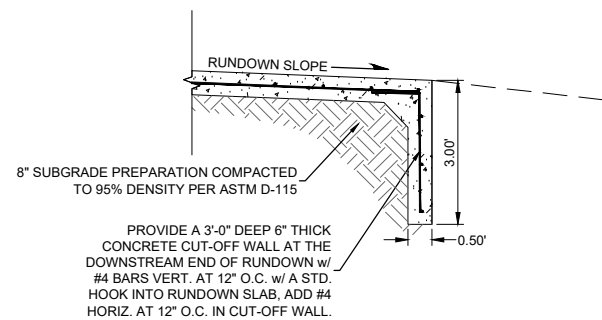

RUNDOWN CUT-OFF WALL DETAILS
SCALE: NOT TO SCALE

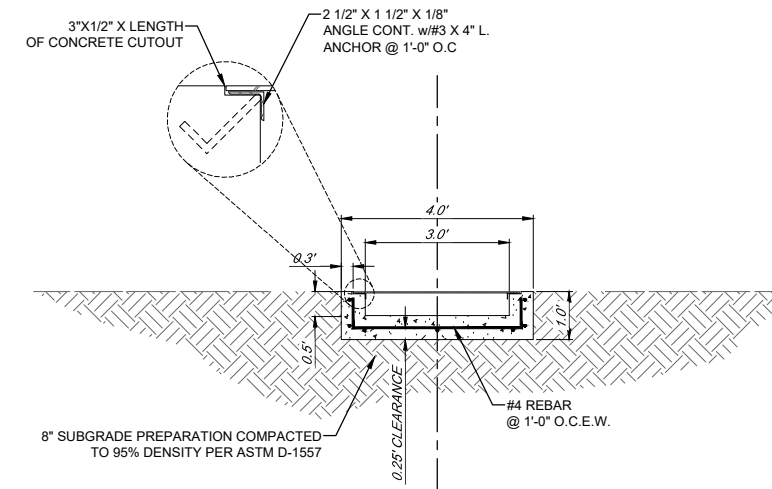

SIDEWALK TRENCH SECTION DETAIL
SCALE: NOT TO SCALE

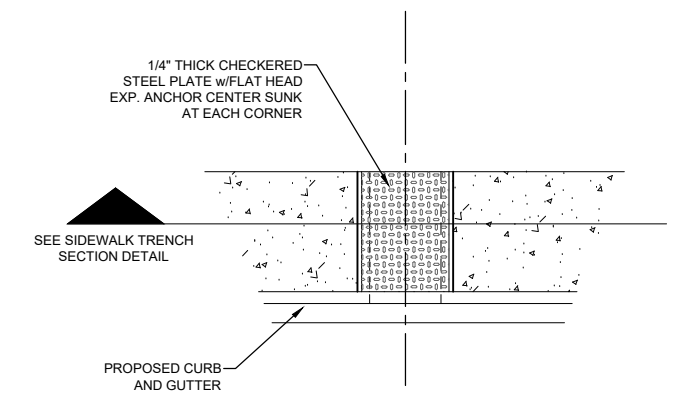

SIDEWALK TRENCH DETAIL
SCALE: NOT TO SCALE

REV. NO.	DATE	DESCRIPTION	APPROVED

New Mexico One Call, Inc. Call 2 days before you dig!
NMOC Dial 811 or 1-800-321-2537
 Professional Resources for Damage Prevention



Street Maintenance Program FY2018

CITY OF ALAMOGORDO STANDARD DETAILS
 CITY OF ALAMOGORDO, NEW MEXICO, ENGINEERING DEPARTMENT

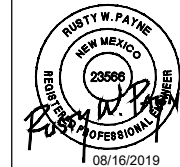

Public Works Bid No.: 2019-002
 Drawn By: COA Designed By: COA
 Checked By: COA Approved By: COA
 Scale: Horiz.: n/a Vert.: n/a
 HORIZ. BAR SCALE
 INCLUDE VERT SCALE ON P&P

Sheet No.: **RC13.0**
 Sheet 19 of 49
 EN1803

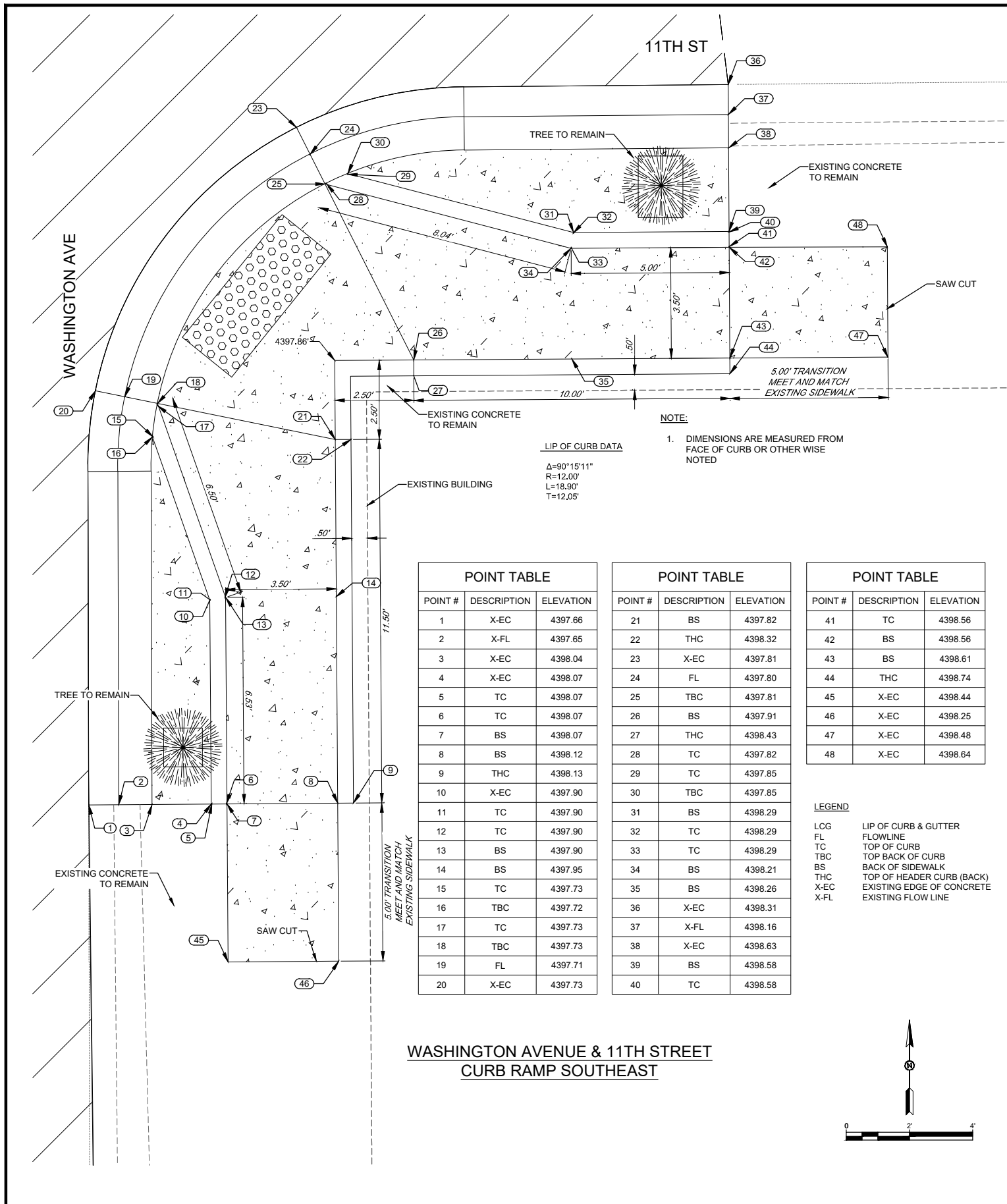

POINT TABLE

POINT #	DESCRIPTION	ELEVATION
1	X-EC	4397.66
2	X-FL	4397.65
3	X-EC	4398.04
4	X-EC	4398.07
5	TC	4398.07
6	TC	4398.07
7	BS	4398.07
8	BS	4398.12
9	THC	4398.13
10	X-EC	4397.90
11	TC	4397.90
12	TC	4397.90
13	BS	4397.90
14	BS	4397.95
15	TC	4397.73
16	TBC	4397.72
17	TC	4397.73
18	TBC	4397.73
19	FL	4397.71
20	X-EC	4397.73

POINT TABLE

POINT #	DESCRIPTION	ELEVATION
21	BS	4397.82
22	THC	4398.32
23	X-EC	4397.81
24	FL	4397.80
25	TBC	4397.81
26	BS	4397.91
27	THC	4398.43
28	TC	4397.82
29	TC	4397.85
30	TBC	4397.85
31	BS	4398.29
32	TC	4398.29
33	TC	4398.29
34	BS	4398.21
35	BS	4398.26
36	X-EC	4398.31
37	X-FL	4398.16
38	X-EC	4398.63
39	BS	4398.58
40	TC	4398.58

POINT TABLE

POINT #	DESCRIPTION	ELEVATION
41	TC	4398.56
42	BS	4398.56
43	BS	4398.61
44	THC	4398.74
45	X-EC	4398.44
46	X-EC	4398.25
47	X-EC	4398.48
48	X-EC	4398.64

LEGEND

LCG LIP OF CURB & GUTTER
 FL FLOWLINE
 TC TOP OF CURB
 TBC TOP BACK OF CURB
 BS BACK OF SIDEWALK
 THC TOP OF HEADER CURB (BACK)
 X-EC EXISTING EDGE OF CONCRETE
 X-FL EXISTING FLOW LINE

WASHINGTON AVENUE & 11TH STREET
CURB RAMP SOUTHEAST

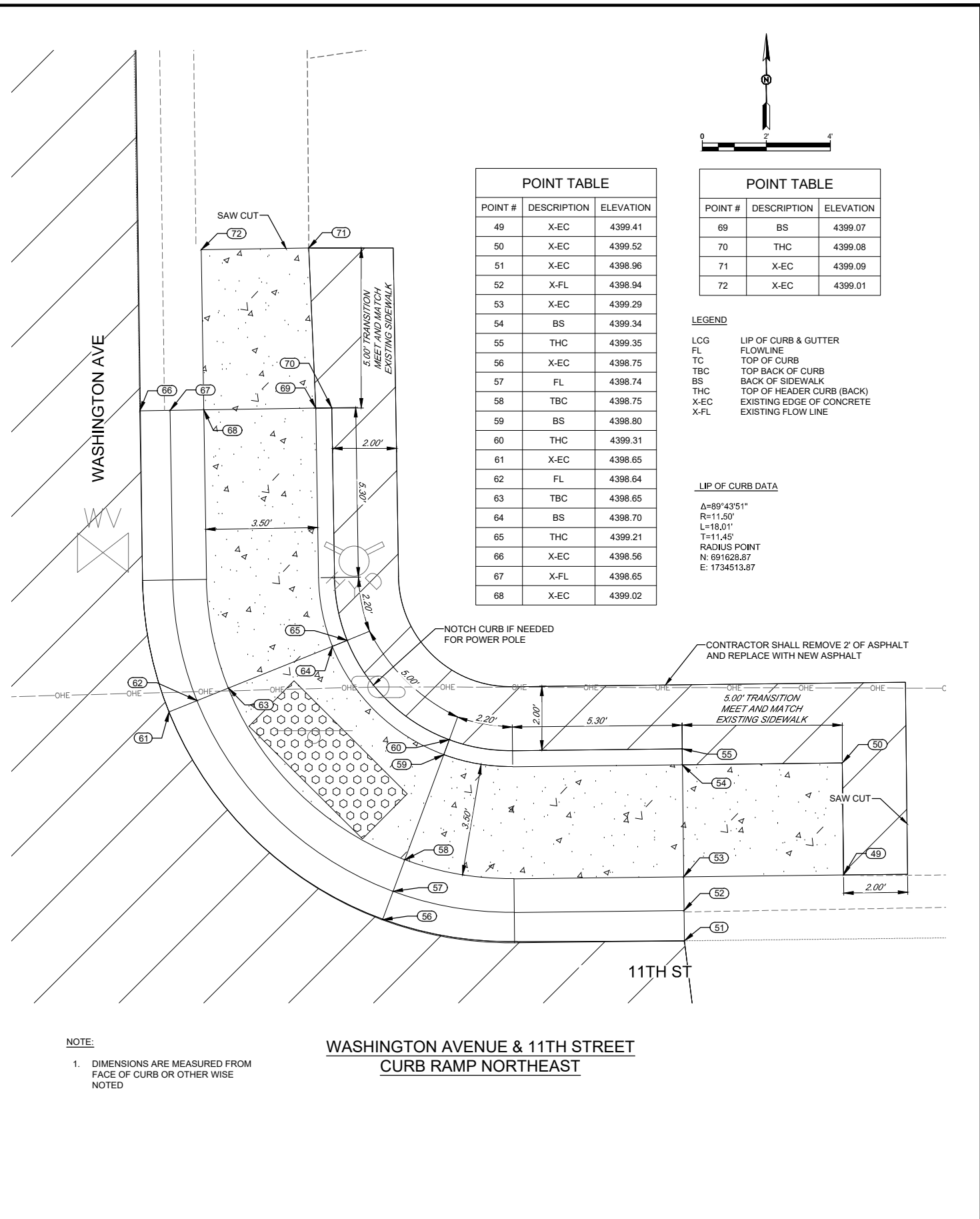
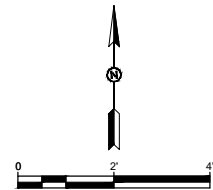

POINT TABLE

POINT #	DESCRIPTION	ELEVATION
49	X-EC	4399.41
50	X-EC	4399.52
51	X-EC	4398.96
52	X-FL	4398.94
53	X-EC	4399.29
54	BS	4399.34
55	THC	4399.35
56	X-EC	4398.75
57	FL	4398.74
58	TBC	4398.75
59	BS	4398.80
60	THC	4399.31
61	X-EC	4398.65
62	FL	4398.64
63	TBC	4398.65
64	BS	4398.70
65	THC	4399.21
66	X-EC	4398.56
67	X-FL	4398.65
68	X-EC	4399.02

POINT TABLE

POINT #	DESCRIPTION	ELEVATION
69	BS	4399.07
70	THC	4399.08
71	X-EC	4399.09
72	X-EC	4399.01

LEGEND

LCG LIP OF CURB & GUTTER
 FL FLOWLINE
 TC TOP OF CURB
 TBC TOP BACK OF CURB
 BS BACK OF SIDEWALK
 THC TOP OF HEADER CURB (BACK)
 X-EC EXISTING EDGE OF CONCRETE
 X-FL EXISTING FLOW LINE

LIP OF CURB DATA

Δ=89°43'51"
 R=11.50'
 L=18.01'
 T=11.45'
 RADIUS POINT
 N: 691628.87
 E: 1734513.87

WASHINGTON AVENUE & 11TH STREET
CURB RAMP NORTHEAST

NOTE:

1. DIMENSIONS ARE MEASURED FROM FACE OF CURB OR OTHERWISE NOTED

REV. No.	DATE	DESCRIPTION	APPROVED

New Mexico One Call, Inc. Call 2 days before you dig!
NMOC Dial 811 or 1-800-321-2537
 Professional Resources for Damage Prevention

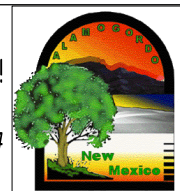

Street Maintenance Program FY2018

WASHINGTON AVENUE & 11TH STREET RAMP DETAILS
 CITY OF ALAMOGORDO, NEW MEXICO, ENGINEERING DEPARTMENT

RUSBY W. PAYNE
 REGISTERED PROFESSIONAL ENGINEER
 No. 23568
 08/16/2019

SMITH ENGINEERING
 Solutions for Tomorrow...
 Vision for Tomorrow
 201 N Church Street
 Suite 200A
 Las Cruces, NM 88001
 Phone: 575-523-2395
 www.smithengineering.pro

Public Works Bid No.: 2019-002
 Drawn By: MM Designed By: MM
 Checked By: RP Approved By: COA
 Scale: Horiz.: n/a Vert.: n/a
 HORIZ. BAR SCALE
 INCLUDE VERT SCALE ON P&P

Sheet No.:
GD1.0
 Sheet 20 of 49
 EN1803

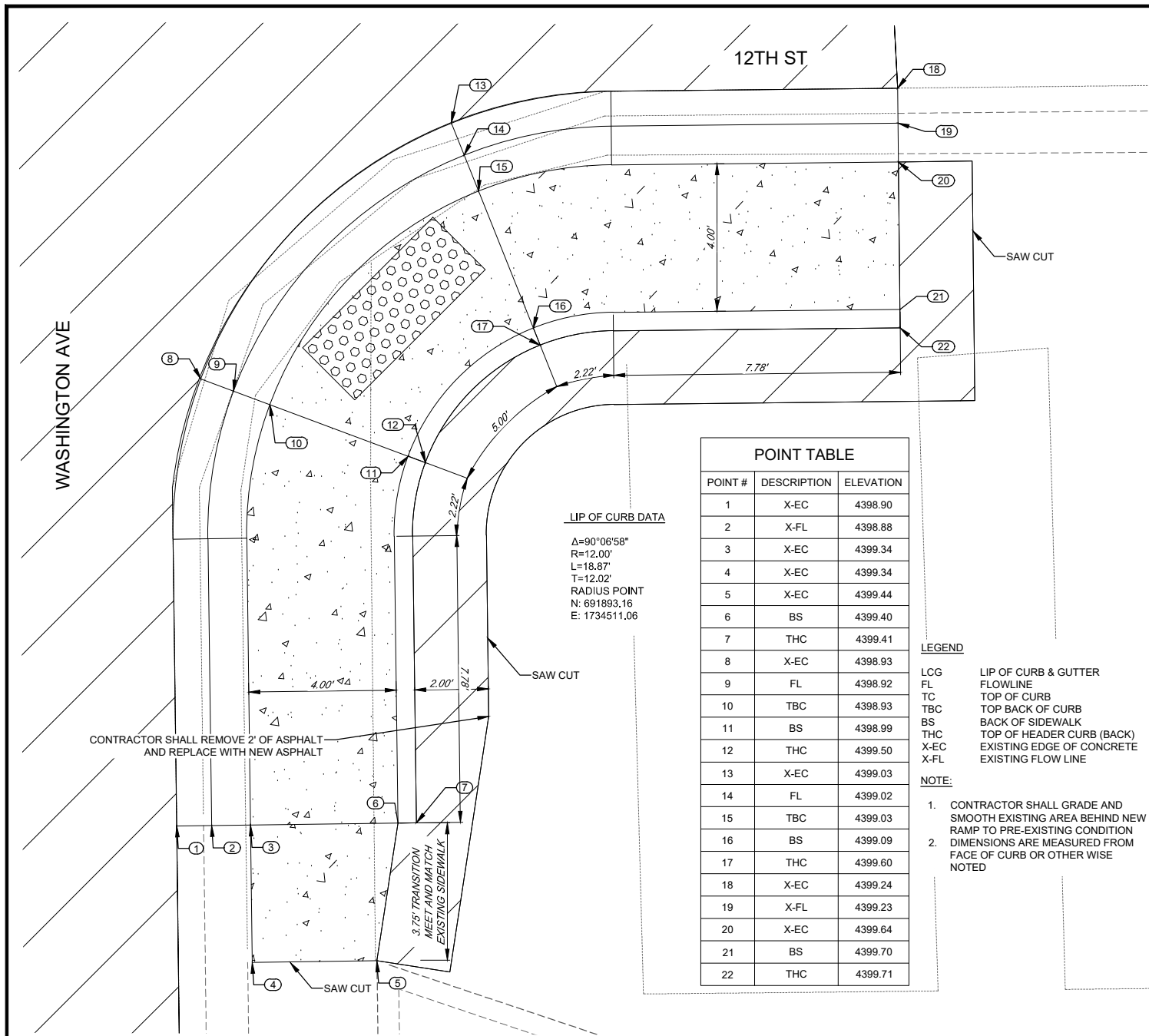

WASHINGTON AVENUE & 12TH STREET
CURB RAMP SOUTHEAST

POINT #	DESCRIPTION	ELEVATION
1	X-EC	4398.90
2	X-FL	4398.88
3	X-EC	4399.34
4	X-EC	4399.34
5	X-EC	4399.44
6	BS	4399.40
7	THC	4399.41
8	X-EC	4398.93
9	FL	4398.92
10	TBC	4398.93
11	BS	4398.99
12	THC	4399.50
13	X-EC	4399.03
14	FL	4399.02
15	TBC	4399.03
16	BS	4399.09
17	THC	4399.60
18	X-EC	4399.24
19	X-FL	4399.23
20	X-EC	4399.64
21	BS	4399.70
22	THC	4399.71

LIP OF CURB DATA
 $\Delta=90^{\circ}06'58''$
 $R=12.00'$
 $L=18.87'$
 $T=12.02'$
 RADIUS POINT
 N: 691893.16
 E: 1734511.06

- LEGEND**
- LCG LIP OF CURB & GUTTER
 - FL FLOWLINE
 - TC TOP OF CURB
 - TBC TOP BACK OF CURB
 - BS BACK OF SIDEWALK
 - THC TOP OF HEADER CURB (BACK)
 - X-EC EXISTING EDGE OF CONCRETE
 - X-FL EXISTING FLOW LINE
- NOTE:**
- CONTRACTOR SHALL GRADE AND SMOOTH EXISTING AREA BEHIND NEW RAMP TO PRE-EXISTING CONDITION
 - DIMENSIONS ARE MEASURED FROM FACE OF CURB OR OTHER WISE NOTED

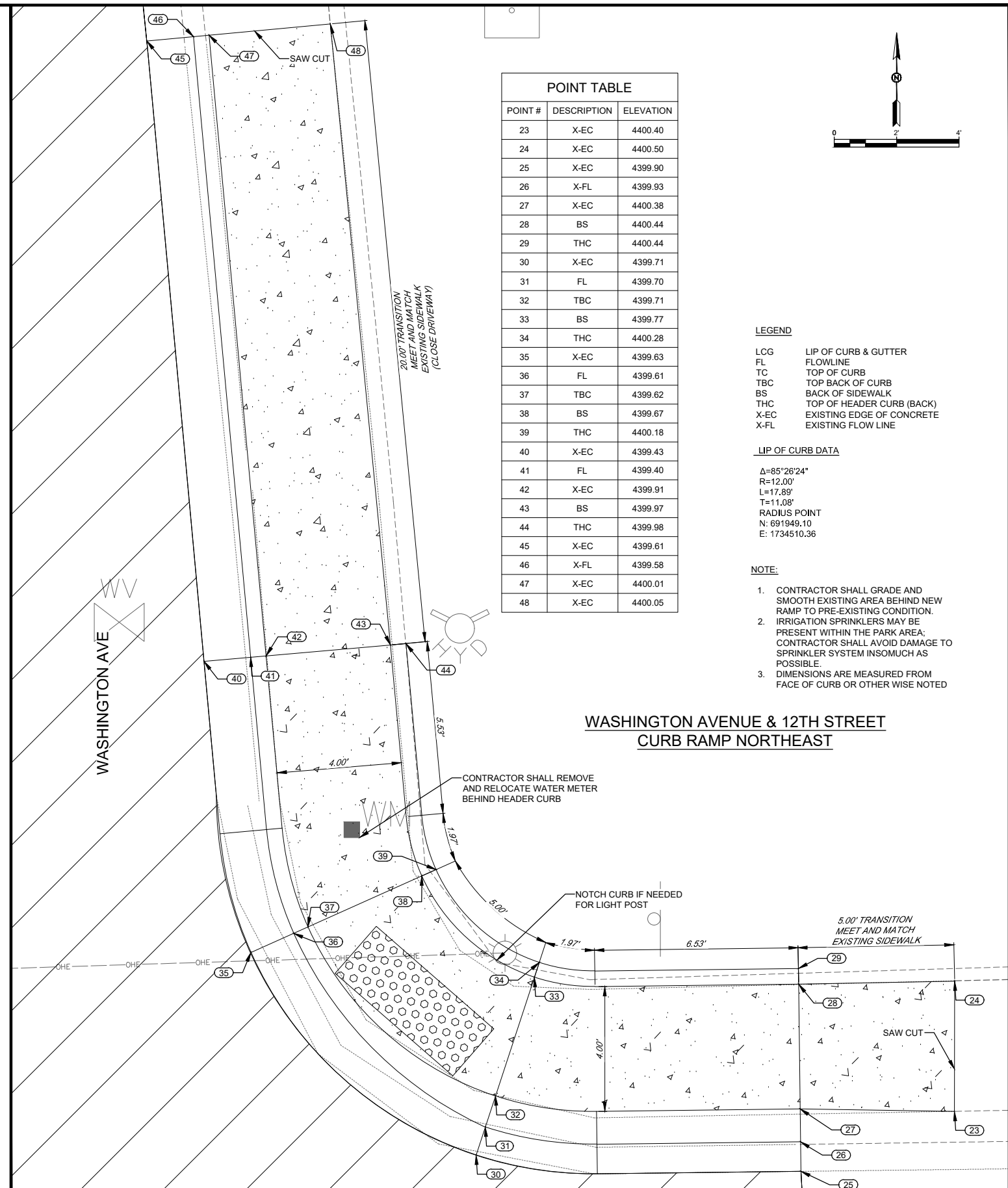

WASHINGTON AVENUE & 12TH STREET
CURB RAMP NORTHEAST

POINT #	DESCRIPTION	ELEVATION
23	X-EC	4400.40
24	X-EC	4400.50
25	X-EC	4399.90
26	X-FL	4399.93
27	X-EC	4400.38
28	BS	4400.44
29	THC	4400.44
30	X-EC	4399.71
31	FL	4399.70
32	TBC	4399.71
33	BS	4399.77
34	THC	4400.28
35	X-EC	4399.63
36	FL	4399.61
37	TBC	4399.62
38	BS	4399.67
39	THC	4400.18
40	X-EC	4399.43
41	FL	4399.40
42	X-EC	4399.91
43	BS	4399.97
44	THC	4399.98
45	X-EC	4399.61
46	X-FL	4399.58
47	X-EC	4400.01
48	X-EC	4400.05

- LEGEND**
- LCG LIP OF CURB & GUTTER
 - FL FLOWLINE
 - TC TOP OF CURB
 - TBC TOP BACK OF CURB
 - BS BACK OF SIDEWALK
 - THC TOP OF HEADER CURB (BACK)
 - X-EC EXISTING EDGE OF CONCRETE
 - X-FL EXISTING FLOW LINE

LIP OF CURB DATA
 $\Delta=85^{\circ}26'24''$
 $R=12.00'$
 $L=17.89'$
 $T=11.08'$
 RADIUS POINT
 N: 691949.10
 E: 1734510.36

- NOTE:**
- CONTRACTOR SHALL GRADE AND SMOOTH EXISTING AREA BEHIND NEW RAMP TO PRE-EXISTING CONDITION. IRRIGATION SPRINKLERS MAY BE PRESENT WITHIN THE PARK AREA; CONTRACTOR SHALL AVOID DAMAGE TO SPRINKLER SYSTEM INASMUCH AS POSSIBLE.
 - DIMENSIONS ARE MEASURED FROM FACE OF CURB OR OTHER WISE NOTED

REV. No.	DATE	DESCRIPTION	APPROVED

New Mexico One Call, Inc. Call 2 days before you dig!
NMOC Dial 811 or 1-800-321-2537
 Professional Resources for Damage Prevention

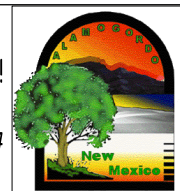

Street Maintenance Program FY2018

WASHINGTON AVENUE & 12TH STREET RAMP DETAILS
 CITY OF ALAMOGORDO, NEW MEXICO, ENGINEERING DEPARTMENT

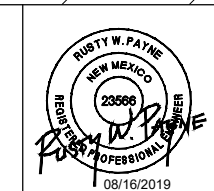

SMITH ENGINEERING
 Solutions for Today... Vision for Tomorrow
 201 N Church Street Suite 200A
 Las Cruces, NM 88001
 Phone: 575-523-2395
 www.smithengineering.pro

Public Works Bid No.: 2019-002

Drawn By: MM Designed By: MM
 Checked By: RP Approved By: COA

Scale: Horiz.: n/a Vert.: n/a
 HORIZ. BAR SCALE
 INCLUDE VERT SCALE ON P&P

Sheet No.: **GD2.0**

Sheet 21 of 49

EN1803

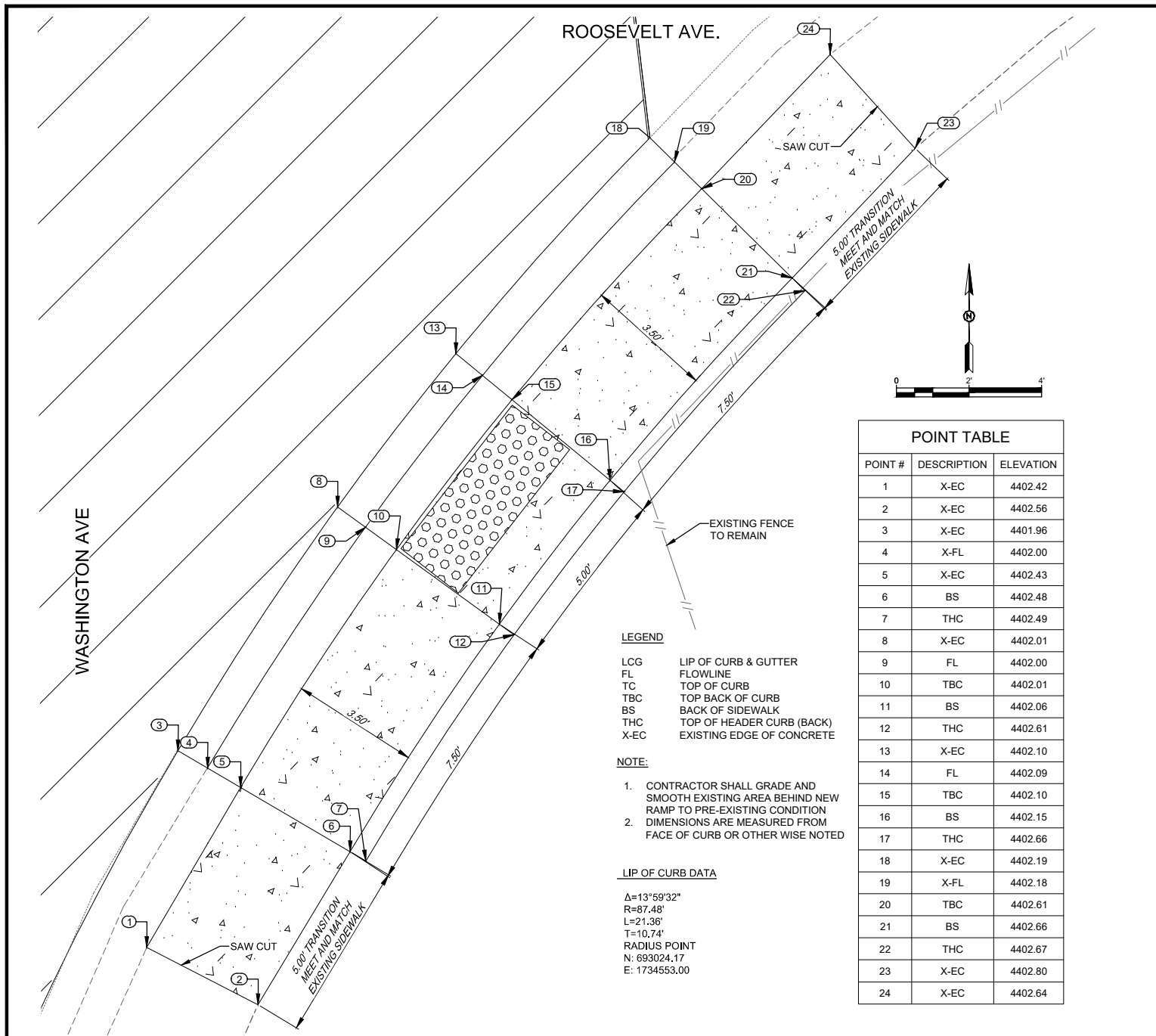

POINT TABLE		
POINT #	DESCRIPTION	ELEVATION
1	X-EC	4402.42
2	X-EC	4402.56
3	X-EC	4401.96
4	X-FL	4402.00
5	X-EC	4402.43
6	BS	4402.48
7	THC	4402.49
8	X-EC	4402.01
9	FL	4402.00
10	TBC	4402.01
11	BS	4402.06
12	THC	4402.61
13	X-EC	4402.10
14	FL	4402.09
15	TBC	4402.10
16	BS	4402.15
17	THC	4402.66
18	X-EC	4402.19
19	X-FL	4402.18
20	TBC	4402.61
21	BS	4402.66
22	THC	4402.67
23	X-EC	4402.80
24	X-EC	4402.64

LEGEND

LCG LIP OF CURB & GUTTER
 FL FLOWLINE
 TC TOP OF CURB
 TBC TOP BACK OF CURB
 BS BACK OF SIDEWALK
 THC TOP OF HEADER CURB (BACK)
 X-EC EXISTING EDGE OF CONCRETE

NOTE:

- CONTRACTOR SHALL GRADE AND SMOOTH EXISTING AREA BEHIND NEW RAMP TO PRE-EXISTING CONDITION
- DIMENSIONS ARE MEASURED FROM FACE OF CURB OR OTHER WISE NOTED

LIP OF CURB DATA

$\Delta=13^{\circ}59'32''$
 $R=87.48'$
 $L=21.36'$
 $T=10.74'$
 RADIUS POINT
 N: 693024.17
 E: 1734553.00

WASHINGTON AVENUE & ROOSEVELT AVENUE
 CURB RAMP SOUTHEAST

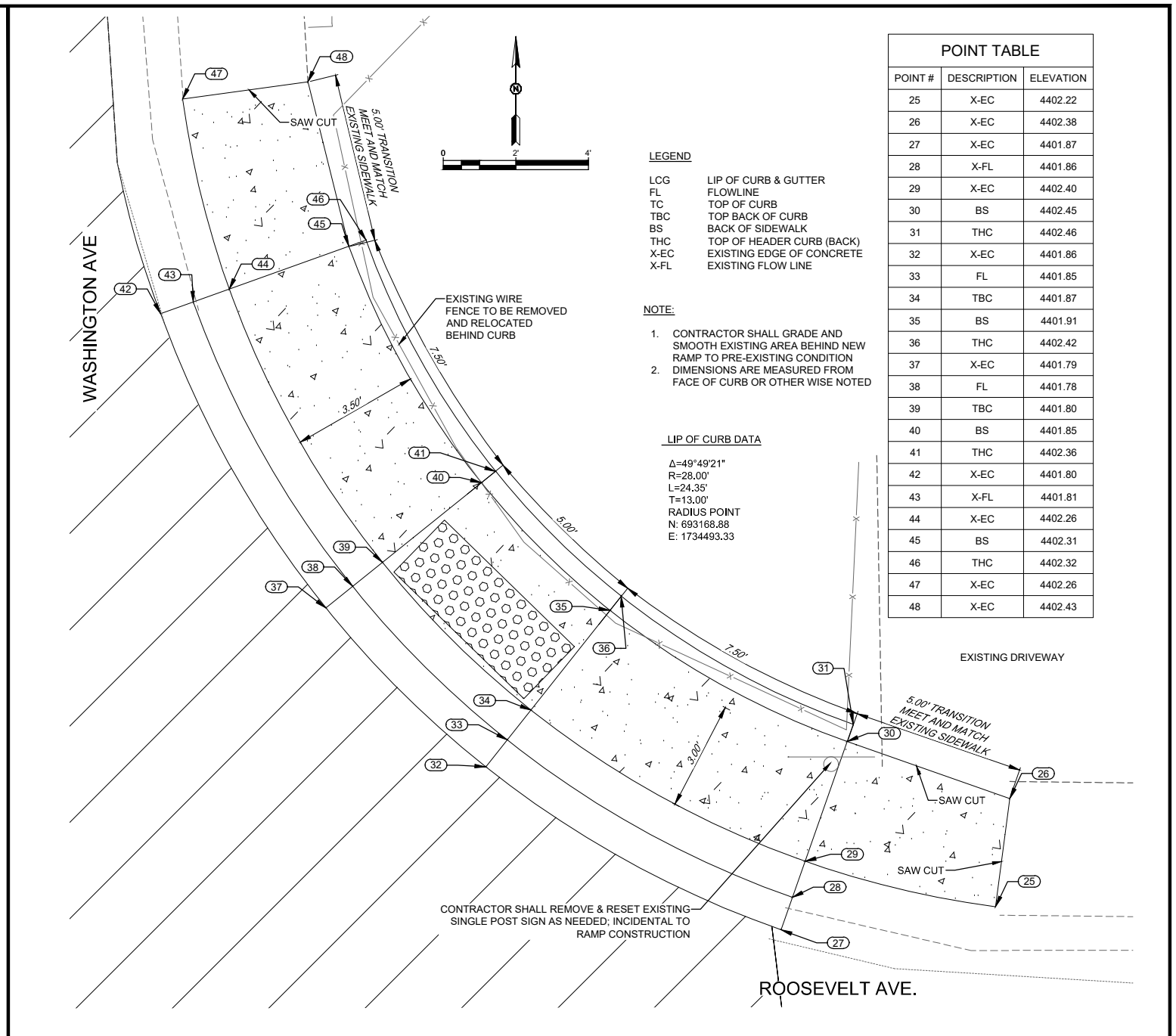

POINT TABLE		
POINT #	DESCRIPTION	ELEVATION
25	X-EC	4402.22
26	X-EC	4402.38
27	X-EC	4401.87
28	X-FL	4401.86
29	X-EC	4402.40
30	BS	4402.45
31	THC	4402.46
32	X-EC	4401.86
33	FL	4401.85
34	TBC	4401.87
35	BS	4401.91
36	THC	4402.42
37	X-EC	4401.79
38	FL	4401.78
39	TBC	4401.80
40	BS	4401.85
41	THC	4402.36
42	X-EC	4401.80
43	X-FL	4401.81
44	X-EC	4402.26
45	BS	4402.31
46	THC	4402.32
47	X-EC	4402.26
48	X-EC	4402.43

LEGEND

LCG LIP OF CURB & GUTTER
 FL FLOWLINE
 TC TOP OF CURB
 TBC TOP BACK OF CURB
 BS BACK OF SIDEWALK
 THC TOP OF HEADER CURB (BACK)
 X-EC EXISTING EDGE OF CONCRETE
 X-FL EXISTING FLOW LINE

NOTE:

- CONTRACTOR SHALL GRADE AND SMOOTH EXISTING AREA BEHIND NEW RAMP TO PRE-EXISTING CONDITION
- DIMENSIONS ARE MEASURED FROM FACE OF CURB OR OTHER WISE NOTED

LIP OF CURB DATA

$\Delta=49^{\circ}49'21''$
 $R=28.00'$
 $L=24.35'$
 $T=13.00'$
 RADIUS POINT
 N: 693168.88
 E: 1734493.33

CONTRACTOR SHALL REMOVE & RESET EXISTING SINGLE POST SIGN AS NEEDED; INCIDENTAL TO RAMP CONSTRUCTION

WASHINGTON AVENUE & ROOSEVELT AVENUE
 CURB RAMP NORTHEAST

REV. No.	DATE	DESCRIPTION	APPROVED

New Mexico One Call, Inc. Call 2 days before you dig!
NMOC Dial 811 or 1-800-321-2537
 Professional Resources for Damage Prevention



Street Maintenance Program FY2018

WASHINGTON AVE. & ROOSEVELT AVE. RAMP DETAILS
 CITY OF ALAMOGORDO, NEW MEXICO, ENGINEERING DEPARTMENT

RUSTY W. PAYNE
 NEW MEXICO
 23566
 REGISTERED PROFESSIONAL ENGINEER
 08/16/2019

SMITH ENGINEERING
 Solutions for Today...
 Vision for Tomorrow
 201 N Church Street
 Suite 200A
 Las Cruces, NM 88001
 Phone: 575-523-2395
 www.smithengineering.pro

Public Works Bid No.: 2019-002
 Drawn By: MM Designed By: MM
 Checked By: RP Approved By: COA

Scale: Horiz.: n/a Vert.: n/a
 HORIZ. BAR SCALE
 INCLUDE VERT SCALE ON P&P

Sheet No.:
GD3.0

Sheet 22 of 49
 EN1803

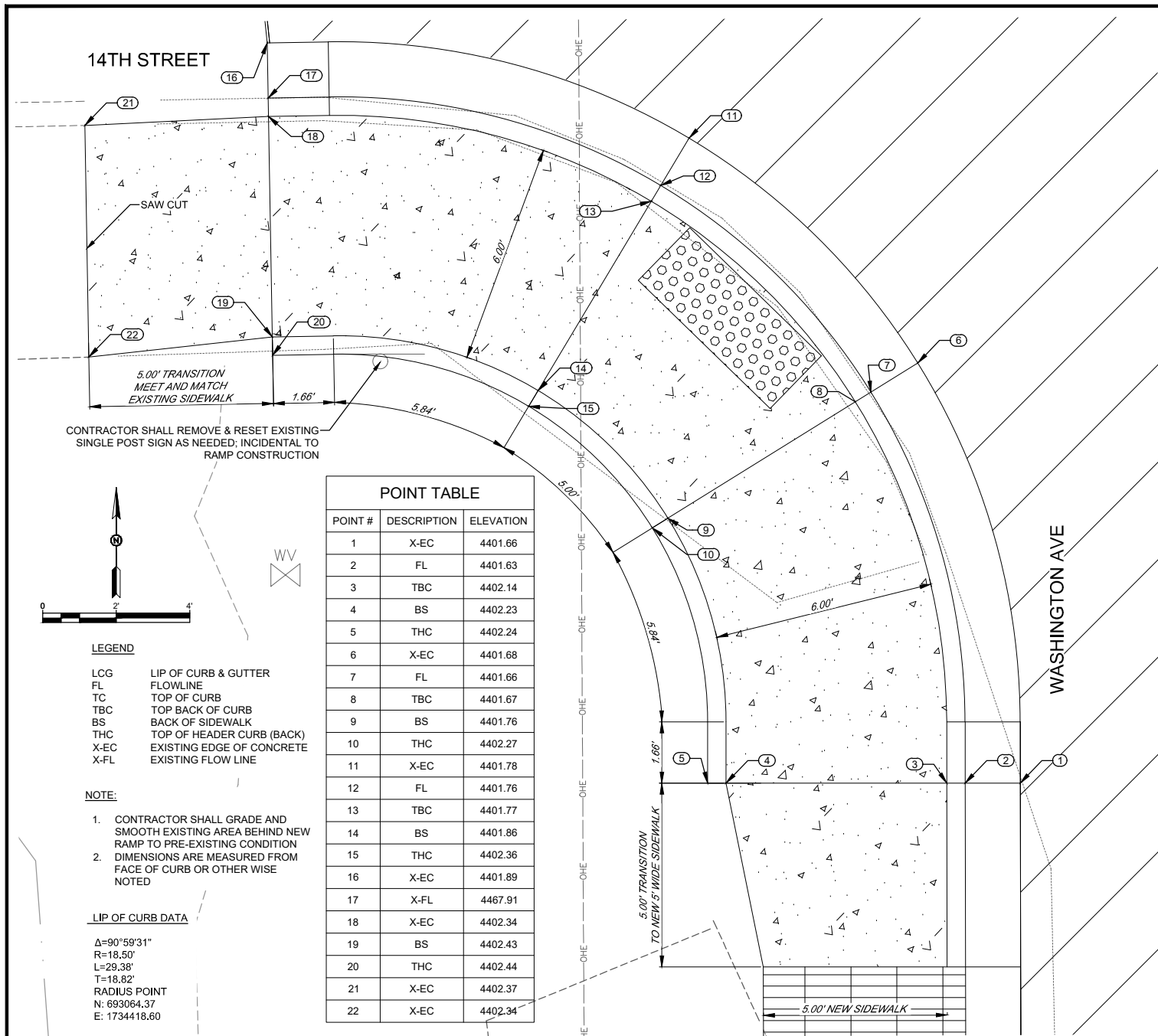

POINT TABLE

POINT #	DESCRIPTION	ELEVATION
1	X-EC	4401.66
2	FL	4401.63
3	TBC	4402.14
4	BS	4402.23
5	THC	4402.24
6	X-EC	4401.68
7	FL	4401.66
8	TBC	4401.67
9	BS	4401.76
10	THC	4402.27
11	X-EC	4401.78
12	FL	4401.76
13	TBC	4401.77
14	BS	4401.86
15	THC	4402.36
16	X-EC	4401.89
17	X-FL	4467.91
18	X-EC	4402.34
19	BS	4402.43
20	THC	4402.44
21	X-EC	4402.37
22	X-EC	4402.34

- LEGEND**
- LCG LIP OF CURB & GUTTER
 - FL FLOWLINE
 - TC TOP OF CURB
 - TBC TOP BACK OF CURB
 - BS BACK OF SIDEWALK
 - THC TOP OF HEADER CURB (BACK)
 - X-EC EXISTING EDGE OF CONCRETE
 - X-FL EXISTING FLOW LINE

- NOTE:**
- CONTRACTOR SHALL GRADE AND SMOOTH EXISTING AREA BEHIND NEW RAMP TO PRE-EXISTING CONDITION
 - DIMENSIONS ARE MEASURED FROM FACE OF CURB OR OTHER WISE NOTED

LIP OF CURB DATA

Δ=90°59'31"
 R=18.50'
 L=29.38'
 T=18.82'
 RADIUS POINT
 N: 693064.37
 E: 1734418.60

**WASHINGTON AVENUE & 14TH STREET
CURB RAMP SOUTHWEST**

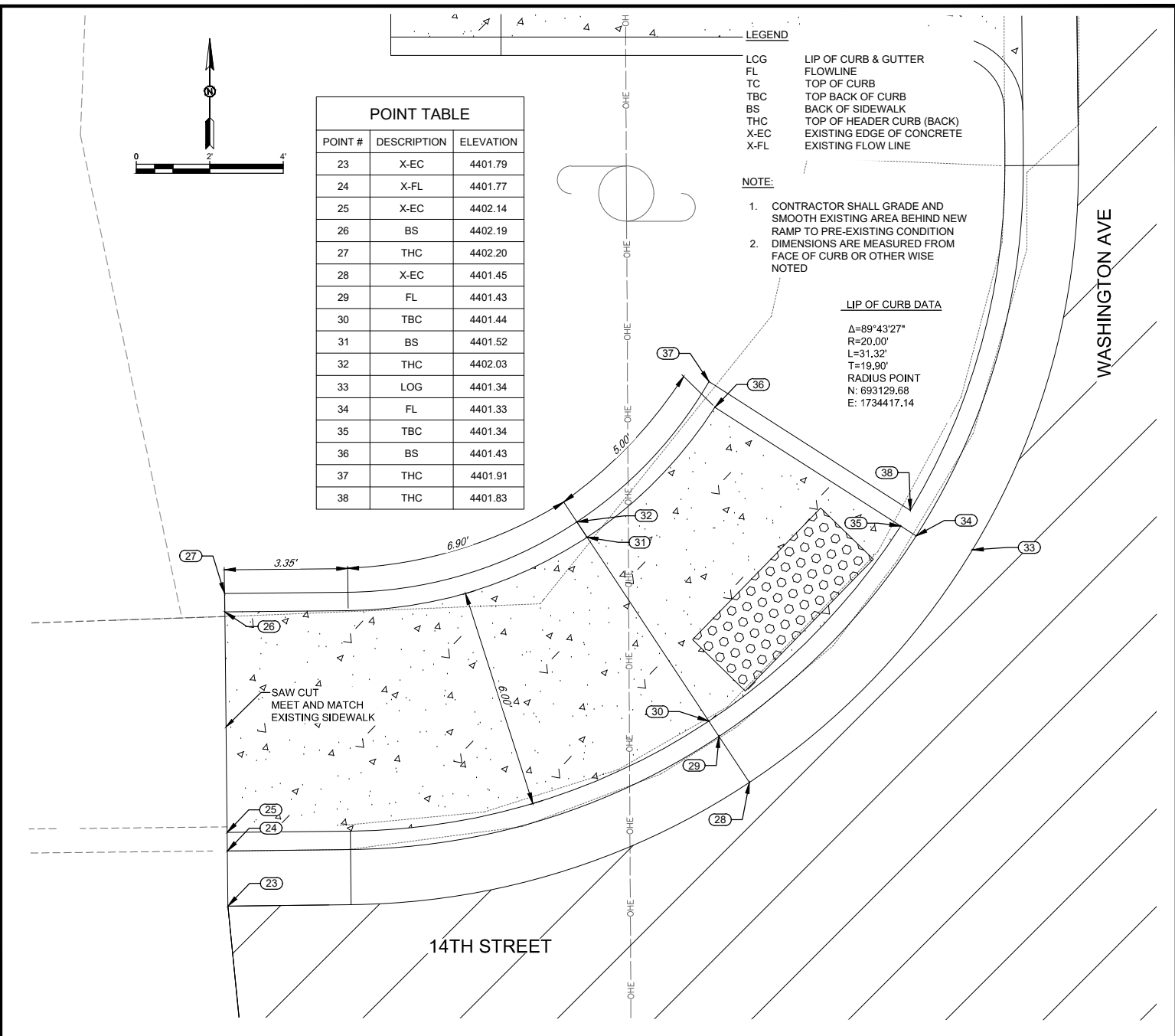

POINT TABLE

POINT #	DESCRIPTION	ELEVATION
23	X-EC	4401.79
24	X-FL	4401.77
25	X-EC	4402.14
26	BS	4402.19
27	THC	4402.20
28	X-EC	4401.45
29	FL	4401.43
30	TBC	4401.44
31	BS	4401.52
32	THC	4402.03
33	LOG	4401.34
34	FL	4401.33
35	TBC	4401.34
36	BS	4401.43
37	THC	4401.91
38	THC	4401.83

- LEGEND**
- LCG LIP OF CURB & GUTTER
 - FL FLOWLINE
 - TC TOP OF CURB
 - TBC TOP BACK OF CURB
 - BS BACK OF SIDEWALK
 - THC TOP OF HEADER CURB (BACK)
 - X-EC EXISTING EDGE OF CONCRETE
 - X-FL EXISTING FLOW LINE

- NOTE:**
- CONTRACTOR SHALL GRADE AND SMOOTH EXISTING AREA BEHIND NEW RAMP TO PRE-EXISTING CONDITION
 - DIMENSIONS ARE MEASURED FROM FACE OF CURB OR OTHER WISE NOTED

LIP OF CURB DATA

Δ=89°43'27"
 R=20.00'
 L=31.32'
 T=19.90'
 RADIUS POINT
 N: 693129.68
 E: 1734417.14

**WASHINGTON AVENUE & 14TH STREET
CURB RAMP NORTHWEST**

REV. No.	DATE	DESCRIPTION	APPROVED

New Mexico One Call, Inc. Call 2 days before you dig!
NMOC Dial 811 or 1-800-321-2537
 Professional Resources for Damage Prevention

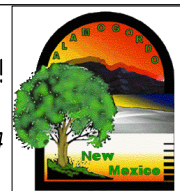

Street Maintenance Program FY2018

WASHINGTON AVENUE & 14TH STREET RAMP DETAILS
 CITY OF ALAMOGORDO, NEW MEXICO, ENGINEERING DEPARTMENT

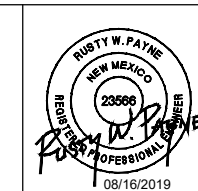

SMITH ENGINEERING
 Solutions for Today... Vision for Tomorrow
 201 N Church Street
 Suite 200A
 Las Cruces, NM 88001
 Phone: 575-523-2395
 www.smithengineering.pro

Public Works Bid No.: 2019-002	Sheet No.:
Drawn By: MM Designed By: MM	GD4.0
Checked By: RP Approved By: COA	Sheet 23 of 49
Scale: Horiz.: n/a Vert.: n/a	EN1803
HORIZ. BAR SCALE INCLUDE VERT SCALE ON P&P	

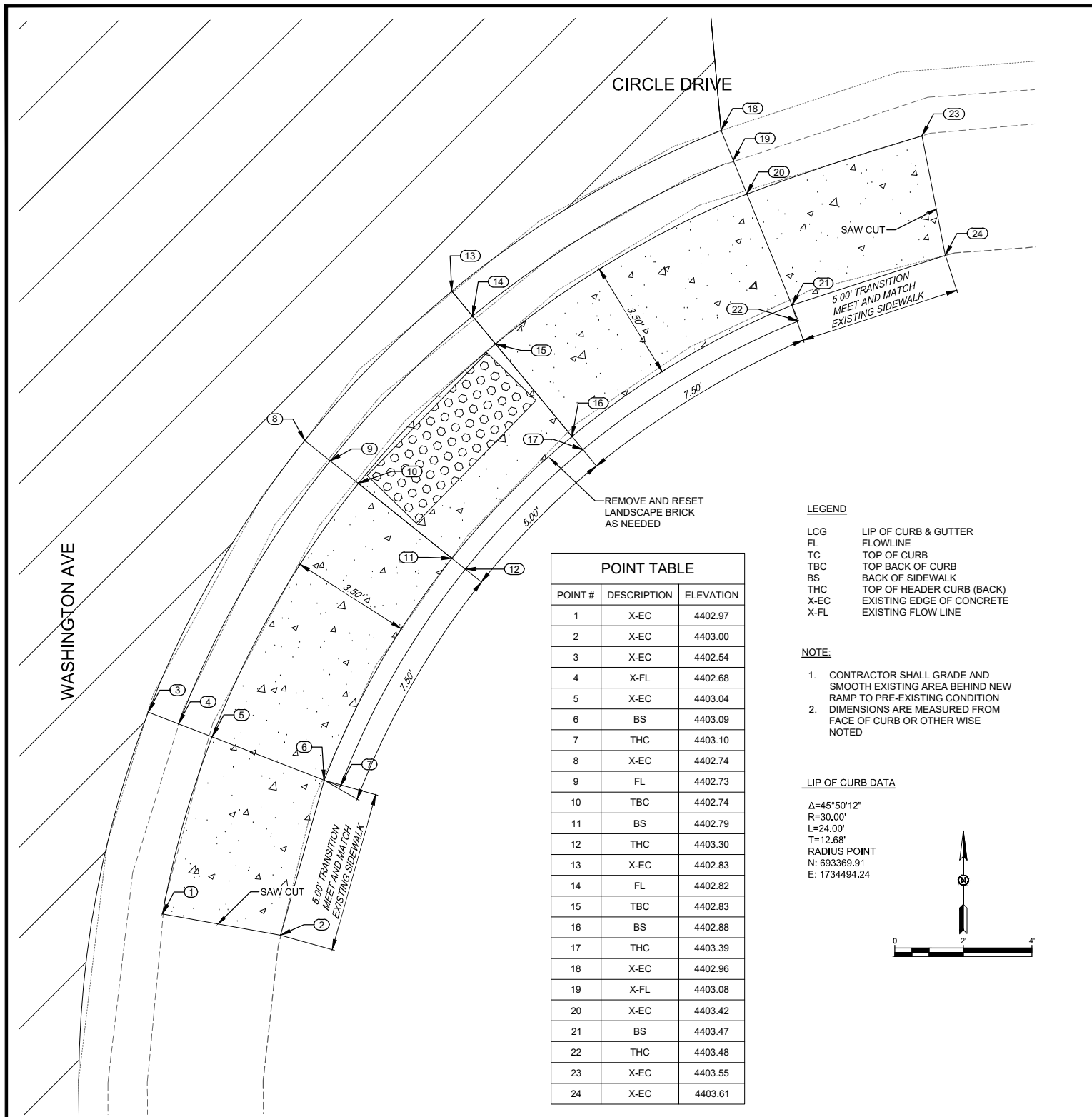

WASHINGTON AVENUE & CIRCLE DRIVE (SOUTH)
CURB RAMP SOUTHEAST

POINT #	DESCRIPTION	ELEVATION
1	X-EC	4402.97
2	X-EC	4403.00
3	X-EC	4402.54
4	X-FL	4402.68
5	X-EC	4403.04
6	BS	4403.09
7	THC	4403.10
8	X-EC	4402.74
9	FL	4402.73
10	TBC	4402.74
11	BS	4402.79
12	THC	4403.30
13	X-EC	4402.83
14	FL	4402.82
15	TBC	4402.83
16	BS	4402.88
17	THC	4403.39
18	X-EC	4402.96
19	X-FL	4403.08
20	X-EC	4403.42
21	BS	4403.47
22	THC	4403.48
23	X-EC	4403.55
24	X-EC	4403.61

LEGEND

LCG LIP OF CURB & GUTTER
 FL FLOWLINE
 TC TOP OF CURB
 TBC TOP BACK OF CURB
 BS BACK OF SIDEWALK
 THC TOP OF HEADER CURB (BACK)
 X-EC EXISTING EDGE OF CONCRETE
 X-FL EXISTING FLOW LINE

NOTE:

- CONTRACTOR SHALL GRADE AND SMOOTH EXISTING AREA BEHIND NEW RAMP TO PRE-EXISTING CONDITION
- DIMENSIONS ARE MEASURED FROM FACE OF CURB OR OTHER WISE NOTED

LIP OF CURB DATA

$\Delta=45^{\circ}50'12''$
 $R=30.00'$
 $L=24.00'$
 $T=12.68'$
 RADIUS POINT
 N: 693369.91
 E: 1734494.24

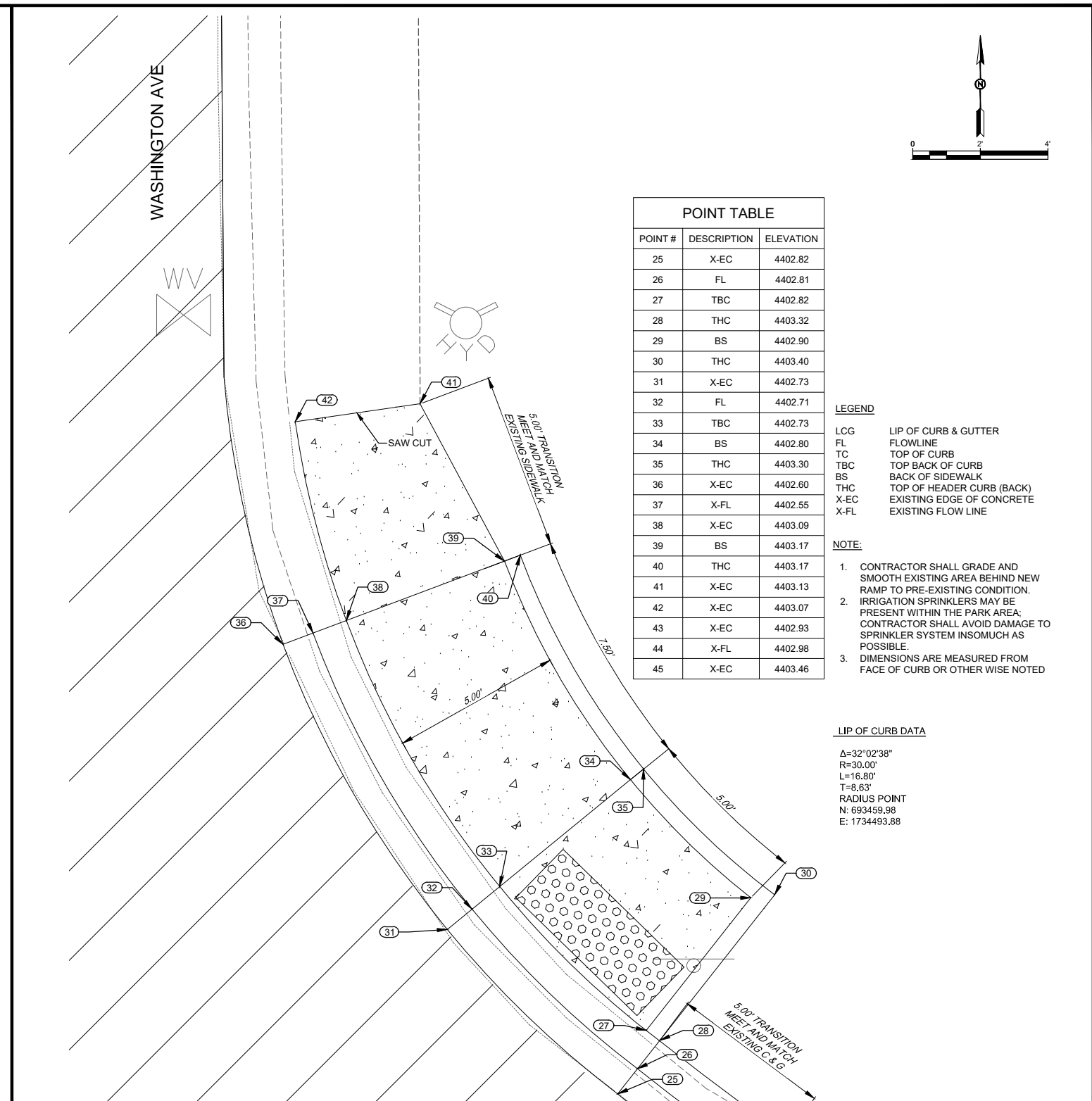
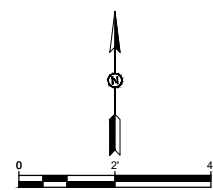

WASHINGTON AVENUE & CIRCLE DRIVE (SOUTH)
CURB RAMP NORTHEAST

POINT #	DESCRIPTION	ELEVATION
25	X-EC	4402.82
26	FL	4402.81
27	TBC	4402.82
28	THC	4403.32
29	BS	4402.90
30	THC	4403.40
31	X-EC	4402.73
32	FL	4402.71
33	TBC	4402.73
34	BS	4402.80
35	THC	4403.30
36	X-EC	4402.60
37	X-FL	4402.55
38	X-EC	4403.09
39	BS	4403.17
40	THC	4403.17
41	X-EC	4403.13
42	X-EC	4403.07
43	X-EC	4402.93
44	X-FL	4402.98
45	X-EC	4403.46

LEGEND

LCG LIP OF CURB & GUTTER
 FL FLOWLINE
 TC TOP OF CURB
 TBC TOP BACK OF CURB
 BS BACK OF SIDEWALK
 THC TOP OF HEADER CURB (BACK)
 X-EC EXISTING EDGE OF CONCRETE
 X-FL EXISTING FLOW LINE

NOTE:

- CONTRACTOR SHALL GRADE AND SMOOTH EXISTING AREA BEHIND NEW RAMP TO PRE-EXISTING CONDITION. IRRIGATION SPRINKLERS MAY BE PRESENT WITHIN THE PARK AREA; CONTRACTOR SHALL AVOID DAMAGE TO SPRINKLER SYSTEM INSOMUCH AS POSSIBLE.
- DIMENSIONS ARE MEASURED FROM FACE OF CURB OR OTHER WISE NOTED

LIP OF CURB DATA

$\Delta=32^{\circ}02'38''$
 $R=30.00'$
 $L=16.80'$
 $T=8.63'$
 RADIUS POINT
 N: 693459.98
 E: 1734493.88

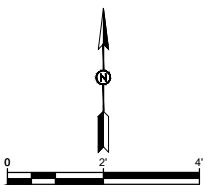

REV. No.	DATE	DESCRIPTION	APPROVED

New Mexico One Call, Inc. Call 2 days before you dig!
NMOC Dial 811 or 1-800-321-2537
 Professional Resources for Damage Prevention

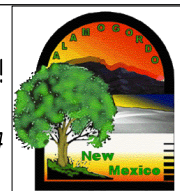

Street Maintenance Program FY2018

WASHINGTON AVE. & CIRCLE DR. SOUTH RAMP DETAILS

CITY OF ALAMOGORDO, NEW MEXICO, ENGINEERING DEPARTMENT

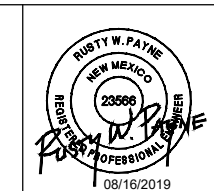

SMITH ENGINEERING
 Solutions for Today...
 Vision for Tomorrow
 201 N Church Street
 Suite 200A
 Las Cruces, NM 88001
 Phone: 575-523-2395
 www.smithengineering.pro

Public Works Bid No.: 2019-002
 Drawn By: MM Designed By: MM
 Checked By: RP Approved By: COA
 Scale: Horiz.: n/a Vert.: n/a
 HORIZ. BAR SCALE
 INCLUDE VERT SCALE ON P&P

Sheet No.:
GD5.0
 Sheet 24 of 49
 EN1803

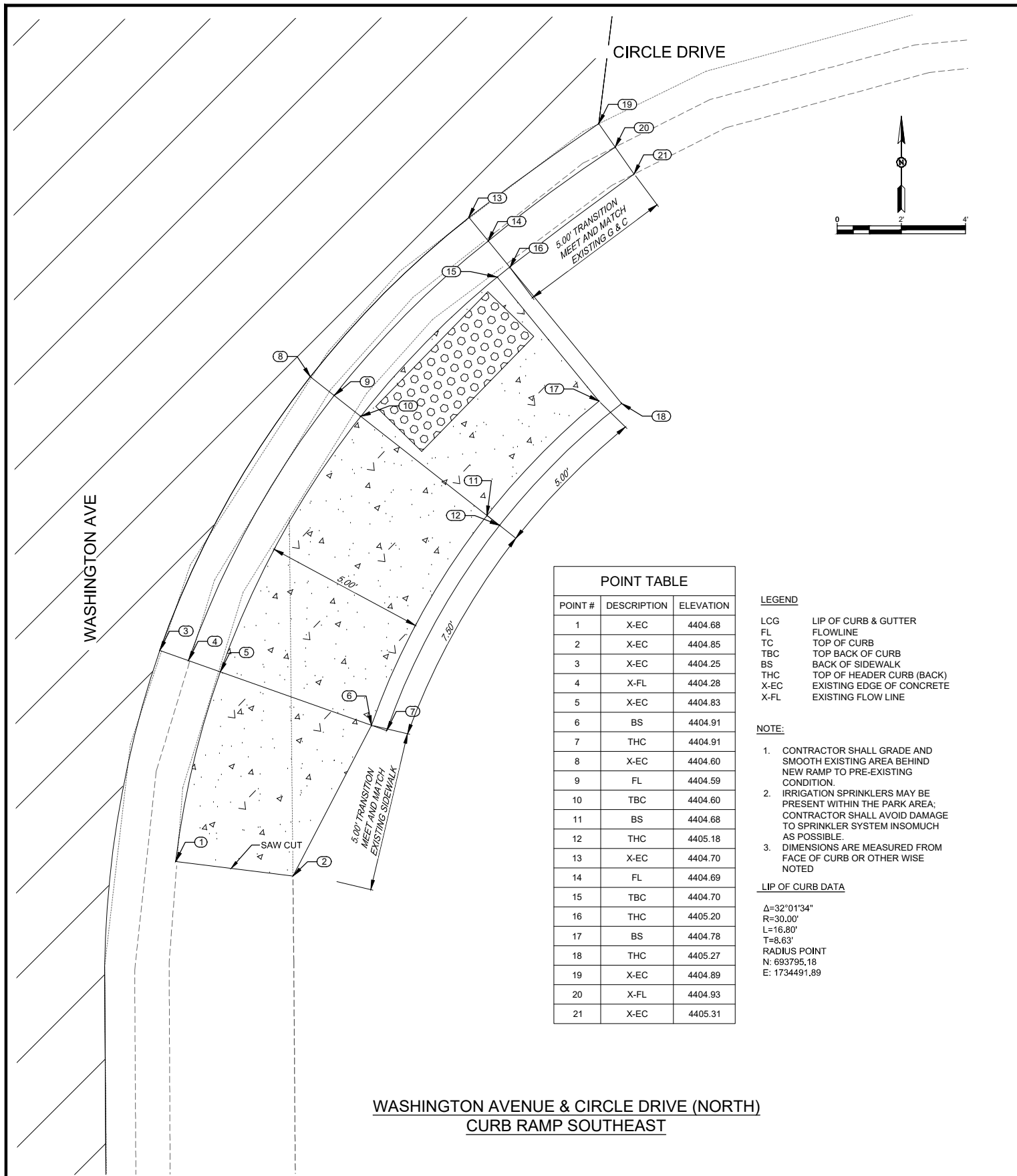

POINT #	DESCRIPTION	ELEVATION
1	X-EC	4404.68
2	X-EC	4404.85
3	X-EC	4404.25
4	X-FL	4404.28
5	X-EC	4404.83
6	BS	4404.91
7	THC	4404.91
8	X-EC	4404.60
9	FL	4404.59
10	TBC	4404.60
11	BS	4404.68
12	THC	4405.18
13	X-EC	4404.70
14	FL	4404.69
15	TBC	4404.70
16	THC	4405.20
17	BS	4404.78
18	THC	4405.27
19	X-EC	4404.89
20	X-FL	4404.93
21	X-EC	4405.31

- LEGEND**
- LCG LIP OF CURB & GUTTER
 - FL FLOWLINE
 - TC TOP OF CURB
 - TBC TOP BACK OF CURB
 - BS BACK OF SIDEWALK
 - THC TOP OF HEADER CURB (BACK)
 - X-EC EXISTING EDGE OF CONCRETE
 - X-FL EXISTING FLOW LINE

- NOTE:**
1. CONTRACTOR SHALL GRADE AND SMOOTH EXISTING AREA BEHIND NEW RAMP TO PRE-EXISTING CONDITION.
 2. IRRIGATION SPRINKLERS MAY BE PRESENT WITHIN THE PARK AREA; CONTRACTOR SHALL AVOID DAMAGE TO SPRINKLER SYSTEM INSOMUCH AS POSSIBLE.
 3. DIMENSIONS ARE MEASURED FROM FACE OF CURB OR OTHER WISE NOTED

LIP OF CURB DATA

Δ=32°01'34"
 R=30.00'
 L=16.80'
 T=8.63'
 RADIUS POINT
 N: 693795.18
 E: 1734491.89

WASHINGTON AVENUE & CIRCLE DRIVE (NORTH)
 CURB RAMP SOUTHEAST

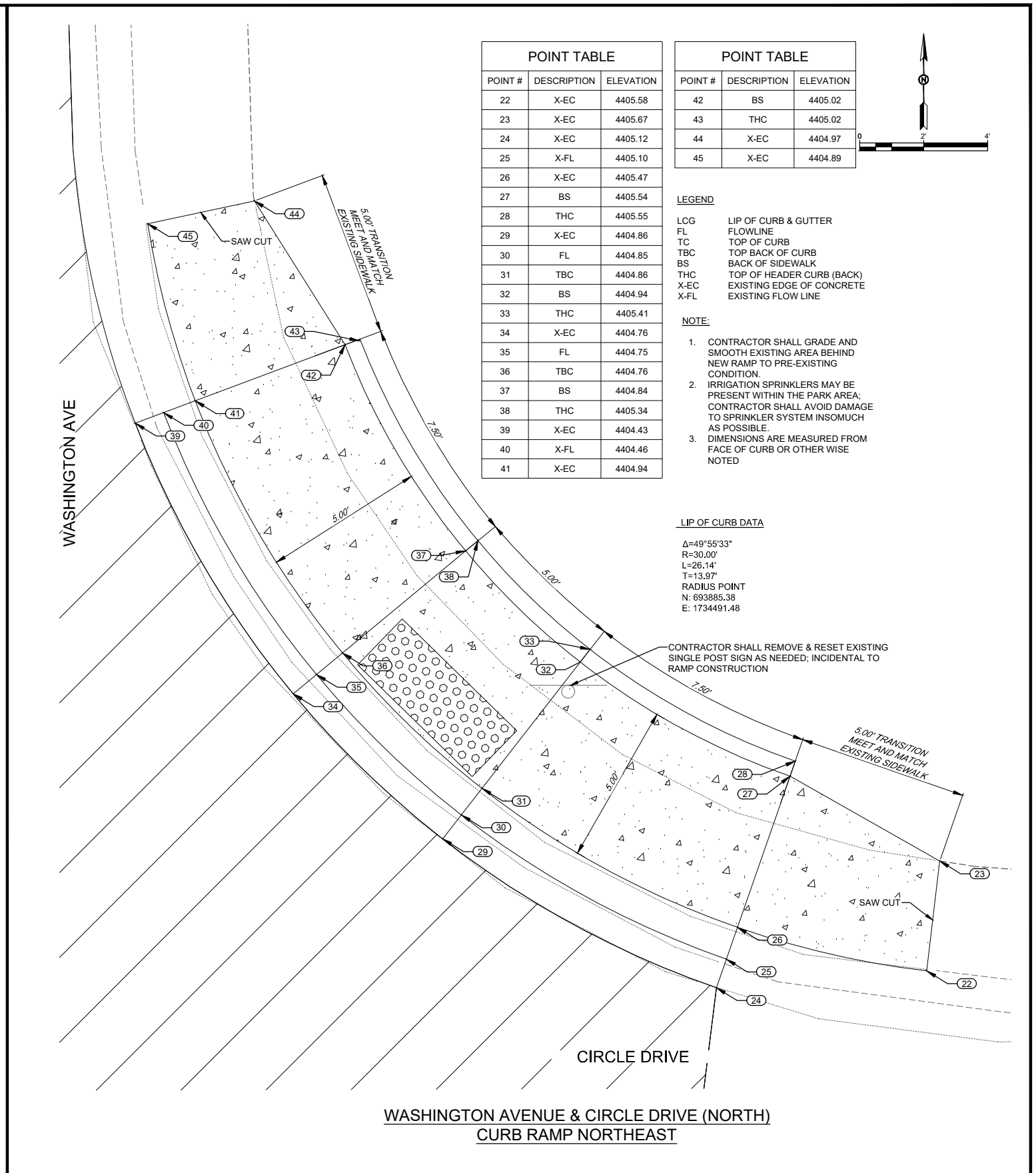

POINT #	DESCRIPTION	ELEVATION
22	X-EC	4405.58
23	X-EC	4405.67
24	X-EC	4405.12
25	X-FL	4405.10
26	X-EC	4405.47
27	BS	4405.54
28	THC	4405.55
29	X-EC	4404.86
30	FL	4404.85
31	TBC	4404.86
32	BS	4404.94
33	THC	4405.41
34	X-EC	4404.76
35	FL	4404.75
36	TBC	4404.76
37	BS	4404.84
38	THC	4405.34
39	X-EC	4404.43
40	X-FL	4404.46
41	X-EC	4404.94

POINT #	DESCRIPTION	ELEVATION
42	BS	4405.02
43	THC	4405.02
44	X-EC	4404.97
45	X-EC	4404.89

- LEGEND**
- LCG LIP OF CURB & GUTTER
 - FL FLOWLINE
 - TC TOP OF CURB
 - TBC TOP BACK OF CURB
 - BS BACK OF SIDEWALK
 - THC TOP OF HEADER CURB (BACK)
 - X-EC EXISTING EDGE OF CONCRETE
 - X-FL EXISTING FLOW LINE

- NOTE:**
1. CONTRACTOR SHALL GRADE AND SMOOTH EXISTING AREA BEHIND NEW RAMP TO PRE-EXISTING CONDITION.
 2. IRRIGATION SPRINKLERS MAY BE PRESENT WITHIN THE PARK AREA; CONTRACTOR SHALL AVOID DAMAGE TO SPRINKLER SYSTEM INSOMUCH AS POSSIBLE.
 3. DIMENSIONS ARE MEASURED FROM FACE OF CURB OR OTHER WISE NOTED

LIP OF CURB DATA

Δ=49°55'33"
 R=30.00'
 L=26.14'
 T=13.97'
 RADIUS POINT
 N: 693885.38
 E: 1734491.48

CONTRACTOR SHALL REMOVE & RESET EXISTING SINGLE POST SIGN AS NEEDED; INCIDENTAL TO RAMP CONSTRUCTION

WASHINGTON AVENUE & CIRCLE DRIVE (NORTH)
 CURB RAMP NORTHEAST

REV. No.	DATE	DESCRIPTION	APPROVED

New Mexico One Call, Inc. Call 2 days before you dig!
NMOC Dial 811 or 1-800-321-2537
 Professional Resources for Damage Prevention



Street Maintenance Program FY2018

WASHINGTON AVE. & CIRCLE DR. NORTH RAMP DETAILS
 CITY OF ALAMOGORDO, NEW MEXICO, ENGINEERING DEPARTMENT

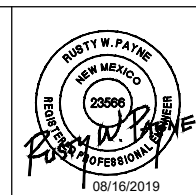

SMITH ENGINEERING
 Solutions for Today...
 Vision for Tomorrow
 201 N Church Street
 Suite 200A
 Las Cruces, NM 88001
 Phone: 575-523-2395
 www.smithengineering.pro

Public Works Bid No.: 2019-002
 Drawn By: MM Designed By: MM
 Checked By: RP Approved By: COA

Scale: Horiz.: n/a Vert.: n/a
 HORIZ. BAR SCALE
 INCLUDE VERT SCALE ON P&P

Sheet No.: **GD6.0**
 Sheet 25 of 49
 EN1803

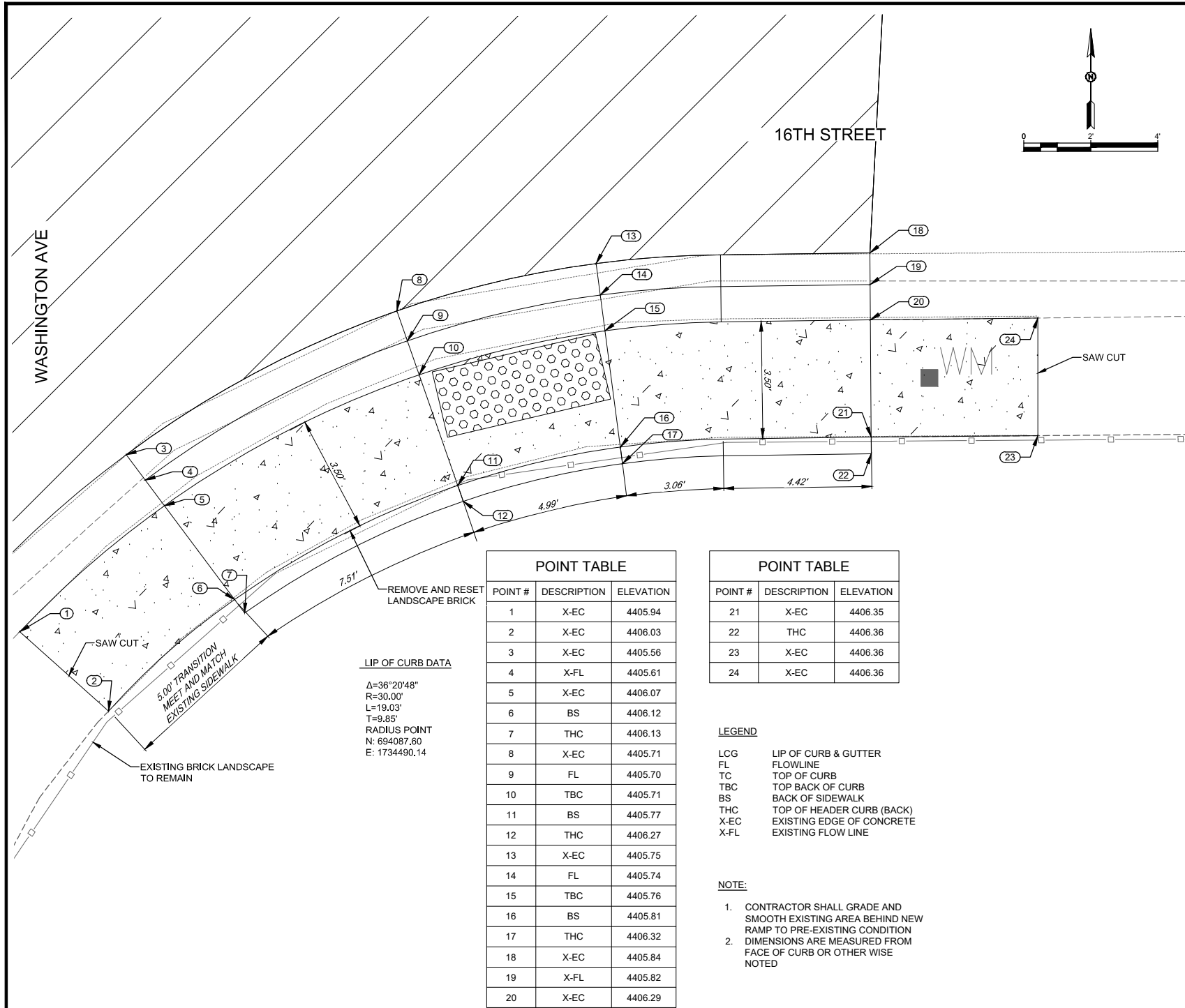

POINT #	DESCRIPTION	ELEVATION
1	X-EC	4405.94
2	X-EC	4406.03
3	X-EC	4405.56
4	X-FL	4405.61
5	X-EC	4406.07
6	BS	4406.12
7	THC	4406.13
8	X-EC	4405.71
9	FL	4405.70
10	TBC	4405.71
11	BS	4405.77
12	THC	4406.27
13	X-EC	4405.75
14	FL	4405.74
15	TBC	4405.76
16	BS	4405.81
17	THC	4406.32
18	X-EC	4405.84
19	X-FL	4405.82
20	X-EC	4406.29

POINT #	DESCRIPTION	ELEVATION
21	X-EC	4406.35
22	THC	4406.36
23	X-EC	4406.36
24	X-EC	4406.36

LEGEND
 LCG LIP OF CURB & GUTTER
 FL FLOWLINE
 TC TOP OF CURB
 TBC TOP BACK OF CURB
 BS BACK OF SIDEWALK
 THC TOP OF HEADER CURB (BACK)
 X-EC EXISTING EDGE OF CONCRETE
 X-FL EXISTING FLOW LINE

NOTE:
 1. CONTRACTOR SHALL GRADE AND SMOOTH EXISTING AREA BEHIND NEW RAMP TO PRE-EXISTING CONDITION
 2. DIMENSIONS ARE MEASURED FROM FACE OF CURB OR OTHER WISE NOTED

LIP OF CURB DATA
 $\Delta=36^{\circ}20'48''$
 $R=30.00'$
 $L=19.03'$
 $T=9.85'$
 RADIUS POINT
 N: 694087.60
 E: 1734490.14

WASHINGTON AVENUE & 16TH STREET
 CURB RAMP SOUTHEAST

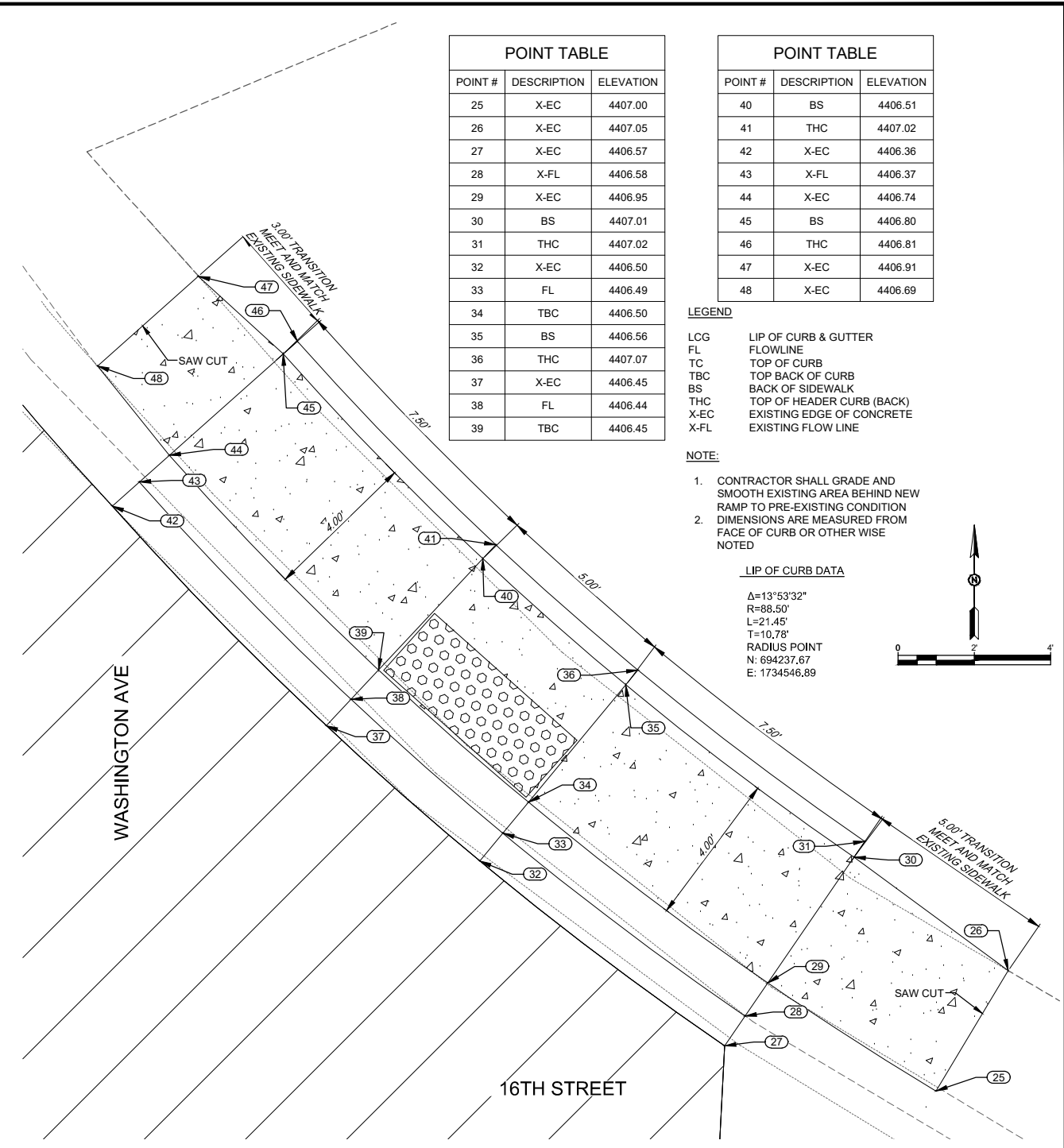

POINT #	DESCRIPTION	ELEVATION
25	X-EC	4407.00
26	X-EC	4407.05
27	X-EC	4406.57
28	X-FL	4406.58
29	X-EC	4406.95
30	BS	4407.01
31	THC	4407.02
32	X-EC	4406.50
33	FL	4406.49
34	TBC	4406.50
35	BS	4406.56
36	THC	4407.07
37	X-EC	4406.45
38	FL	4406.44
39	TBC	4406.45

POINT #	DESCRIPTION	ELEVATION
40	BS	4406.51
41	THC	4407.02
42	X-EC	4406.36
43	X-FL	4406.37
44	X-EC	4406.74
45	BS	4406.80
46	THC	4406.81
47	X-EC	4406.91
48	X-EC	4406.69

LEGEND
 LCG LIP OF CURB & GUTTER
 FL FLOWLINE
 TC TOP OF CURB
 TBC TOP BACK OF CURB
 BS BACK OF SIDEWALK
 THC TOP OF HEADER CURB (BACK)
 X-EC EXISTING EDGE OF CONCRETE
 X-FL EXISTING FLOW LINE

NOTE:
 1. CONTRACTOR SHALL GRADE AND SMOOTH EXISTING AREA BEHIND NEW RAMP TO PRE-EXISTING CONDITION
 2. DIMENSIONS ARE MEASURED FROM FACE OF CURB OR OTHER WISE NOTED

LIP OF CURB DATA
 $\Delta=13^{\circ}53'32''$
 $R=88.50'$
 $L=21.45'$
 $T=10.78'$
 RADIUS POINT
 N: 694237.67
 E: 1734546.89

WASHINGTON AVENUE & 16TH STREET
 CURB RAMP NORTHEAST

REV. No.	DATE	DESCRIPTION	APPROVED

New Mexico One Call, Inc. Call 2 days before you dig!
NMOC Dial 811 or 1-800-321-2537
 Professional Resources for Damage Prevention



Street Maintenance Program FY2018
 WASHINGTON AVENUE & 16TH STREET RAMP DETAILS
 CITY OF ALAMOGORDO, NEW MEXICO, ENGINEERING DEPARTMENT

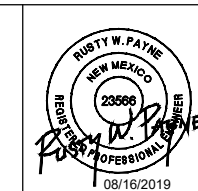

SMITH ENGINEERING
 Solutions for Today... Vision for Tomorrow
 201 N Church Street Suite 200A
 Las Cruces, NM 88001
 Phone: 575-523-2395
 www.smithengineering.pro

Public Works Bid No.: 2019-002
 Drawn By: MM Designed By: MM
 Checked By: RP Approved By: COA
 Scale: Horiz.: n/a Vert.: n/a
 HORIZ. BAR SCALE
 INCLUDE VERT SCALE ON P&P

Sheet No.: **GD7.0**
 Sheet 26 of 49
 EN1803

EXISTING WALK PATH

POINT TABLE		
POINT #	DESCRIPTION	ELEVATION
1	X-EC	4400.57
2	FL	4400.55
3	THC	4401.06
4	THC	4401.14
5	TBC	4400.56
6	BS	4400.63
7	X-EC	4400.61
8	FL	4400.59
9	TBC	4400.60
10	BS	4400.67
11	THC	4401.18
12	X-EC	4400.67
13	FL	4400.64
14	TBC	4401.15
15	BS	4401.23
16	THC	4401.23

LEGEND

- LOG LIP OF CURB & GUTTER
- FL FLOWLINE
- TC TOP OF CURB
- TBC TOP BACK OF CURB
- BS BACK OF SIDEWALK
- THC TOP OF HEADER CURB (BACK)
- X-EC EXISTING EDGE OF CONCRETE
- X-FL EXISTING FLOW LINE

NOTE:

1. CONTRACTOR SHALL GRADE AND SMOOTH EXISTING AREA BEHIND NEW RAMP TO PRE-EXISTING CONDITION
2. DIMENSIONS ARE MEASURED FROM FACE OF CURB OR OTHER WISE NOTED

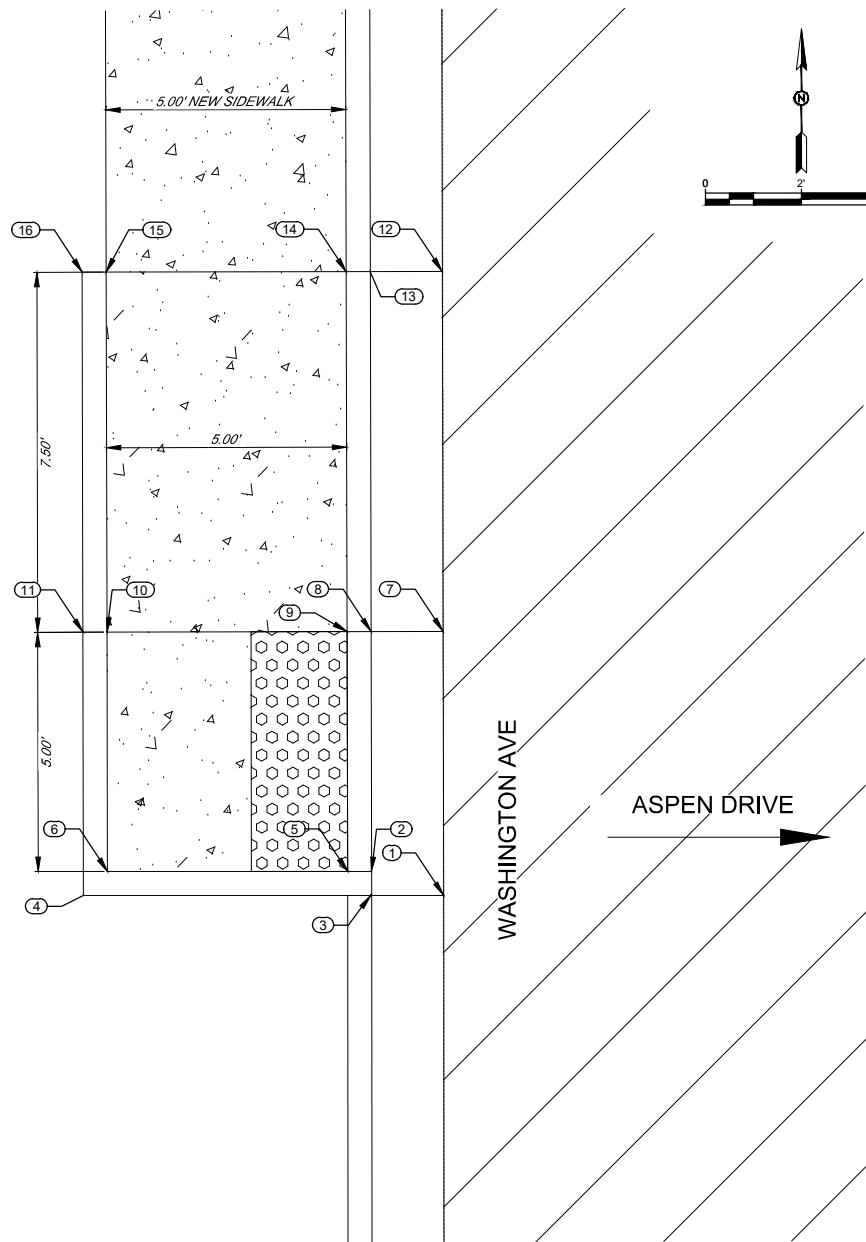

WASHINGTON AVENUE MID-BLOCK @ ASPEN DRIVE
CURB RAMP

POINT TABLE		
POINT #	DESCRIPTION	ELEVATION
17	X-EC	4408.18
18	FL	4408.15
19	TBC	4408.16
20	THC	4408.67
21	BS	4408.24
22	THC	4408.74
23	X-EC	4408.19
24	FL	4408.17
25	TBC	4408.18
26	BS	4408.25
27	THC	4408.76
28	X-EC	4408.22
29	FL	4408.20
30	TBC	4408.70
31	BS	4408.78
32	THC	4408.79

LEGEND

- LOG LIP OF CURB & GUTTER
- FL FLOWLINE
- TC TOP OF CURB
- TBC TOP BACK OF CURB
- BS BACK OF SIDEWALK
- THC TOP OF HEADER CURB (BACK)
- X-EC EXISTING EDGE OF CONCRETE
- X-FL EXISTING FLOW LINE

NOTE:

1. CONTRACTOR SHALL GRADE AND SMOOTH EXISTING AREA BEHIND NEW RAMP TO PRE-EXISTING CONDITION
2. DIMENSIONS ARE MEASURED FROM FACE OF CURB OR OTHER WISE NOTED

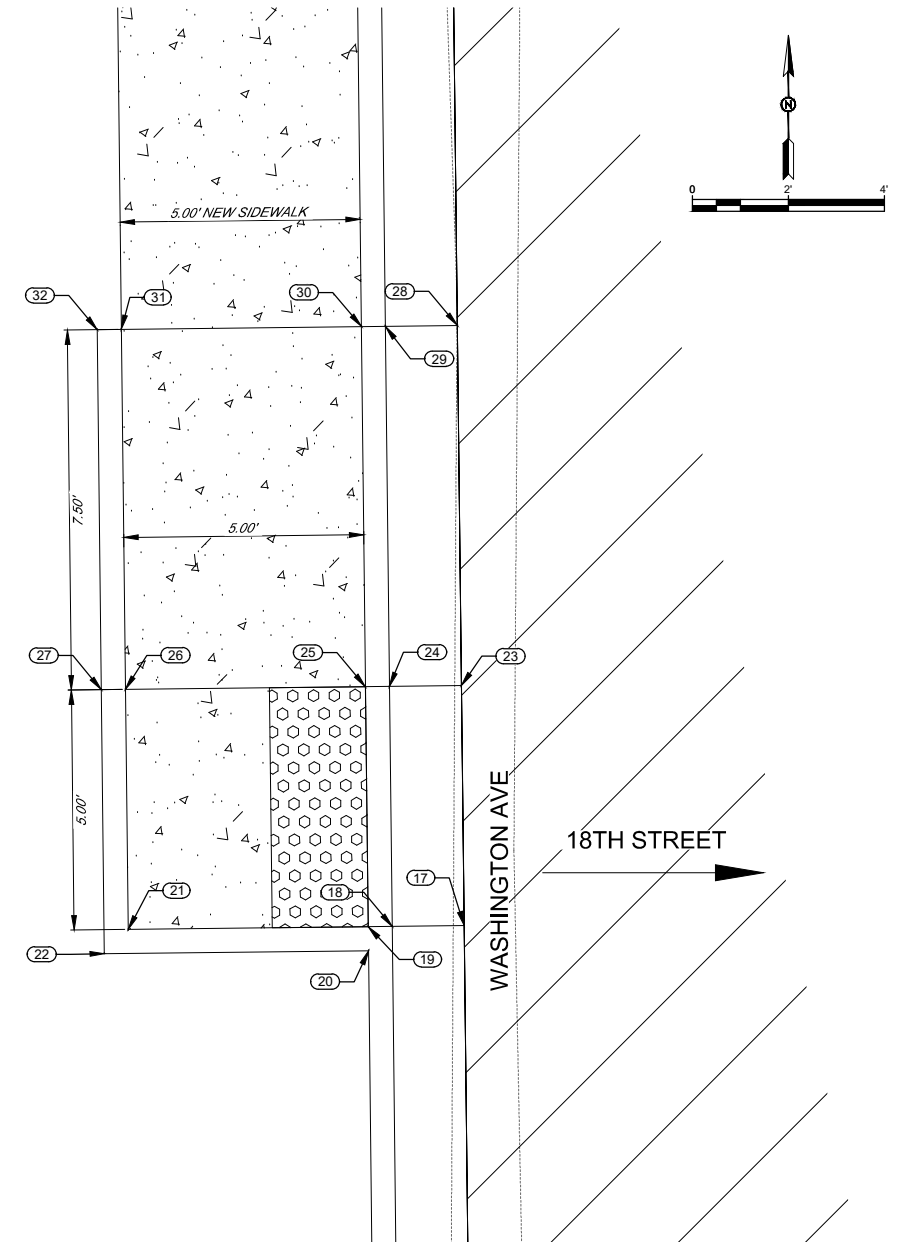

WASHINGTON AVENUE MID-BLOCK @ 18TH STREET
CURB RAMP

REV. No.	DATE	DESCRIPTION	APPROVED

New Mexico One Call, Inc. Call 2 days before you dig!
NMOC Dial 811 or 1-800-321-2537
 Professional Resources for Damage Prevention

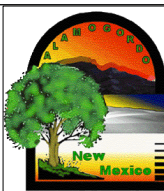

Street Maintenance Program FY2018
 WASHINGTON AVENUE MID-BLOCK RAMP DETAILS
 CITY OF ALAMOGORDO, NEW MEXICO, ENGINEERING DEPARTMENT

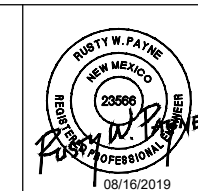

SMITH ENGINEERING
 Solutions for Today... Vision for Tomorrow
 201 N Church Street, Suite 200A, Las Cruces, NM 88001
 Phone: 575-523-2395
 www.smithengineering.pro

Public Works Bid No.: 2019-002	Sheet No.:
Drawn By: MM Designed By: MM	GD8.0
Checked By: RP Approved By: COA	Sheet 27 of 49
Scale: Horiz.: n/a Vert.: n/a	EN1803
HORIZ. BAR SCALE INCLUDE VERT SCALE ON P&P	

FLORIDA AVENUE

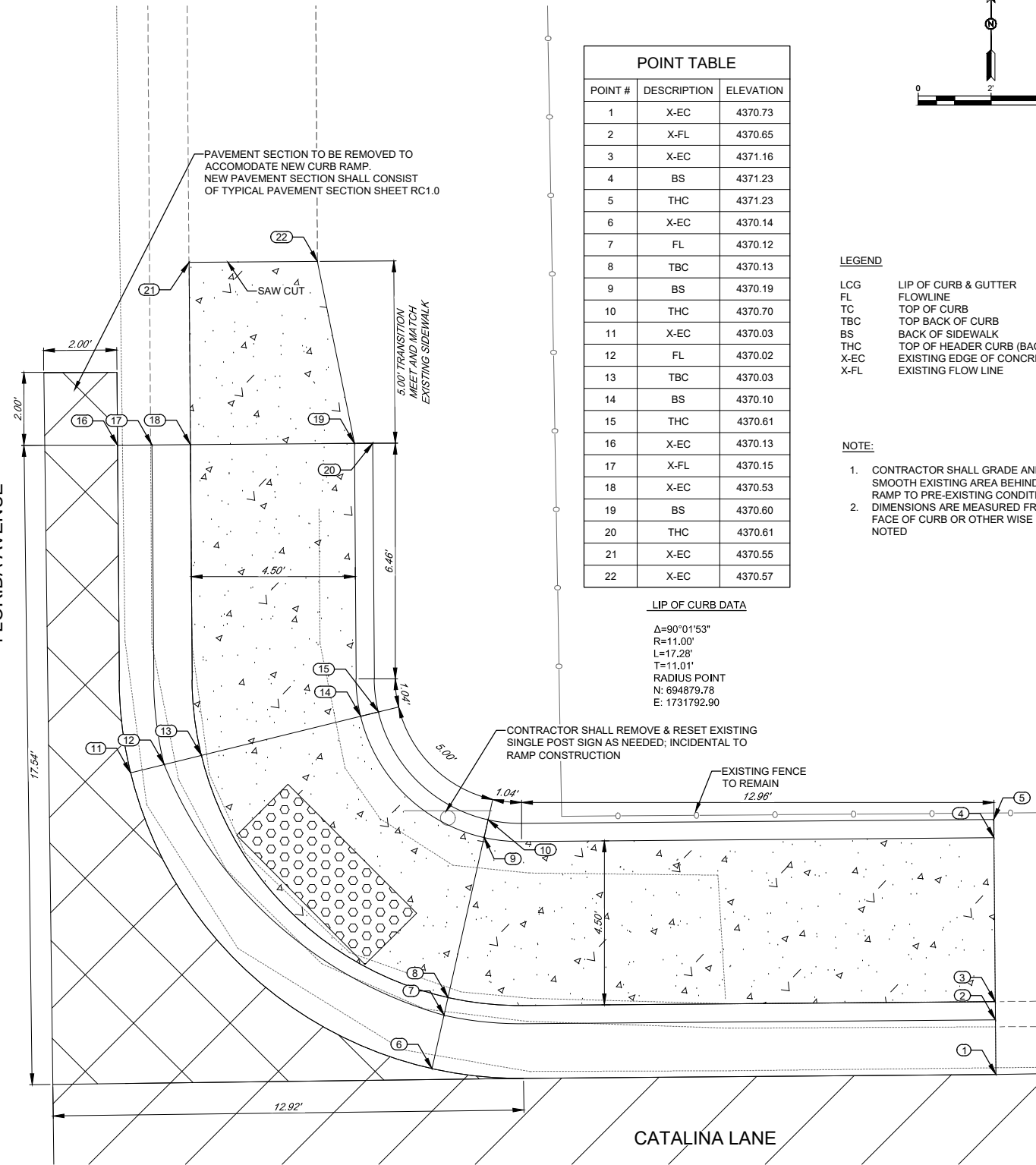

POINT TABLE		
POINT #	DESCRIPTION	ELEVATION
1	X-EC	4370.73
2	X-FL	4370.65
3	X-EC	4371.16
4	BS	4371.23
5	THC	4371.23
6	X-EC	4370.14
7	FL	4370.12
8	TBC	4370.13
9	BS	4370.19
10	THC	4370.70
11	X-EC	4370.03
12	FL	4370.02
13	TBC	4370.03
14	BS	4370.10
15	THC	4370.61
16	X-EC	4370.13
17	X-FL	4370.15
18	X-EC	4370.53
19	BS	4370.60
20	THC	4370.61
21	X-EC	4370.55
22	X-EC	4370.57

LIP OF CURB DATA
 $\Delta=90^{\circ}01'53''$
 $R=11.00'$
 $L=17.28'$
 $T=11.01'$
RADIUS POINT
 N: 694879.78
 E: 1731792.90

LEGEND

- LCG LIP OF CURB & GUTTER
- FL FLOWLINE
- TC TOP OF CURB
- TBC TOP BACK OF CURB
- BS BACK OF SIDEWALK
- THC TOP OF HEADER CURB (BACK)
- X-EC EXISTING EDGE OF CONCRETE
- X-FL EXISTING FLOW LINE

NOTE:

1. CONTRACTOR SHALL GRADE AND SMOOTH EXISTING AREA BEHIND NEW RAMP TO PRE-EXISTING CONDITION
2. DIMENSIONS ARE MEASURED FROM FACE OF CURB OR OTHER WISE NOTED

CATALINA LANE & FLORIDA AVENUE CURB RAMP NORTHEAST

CATALINA LANE

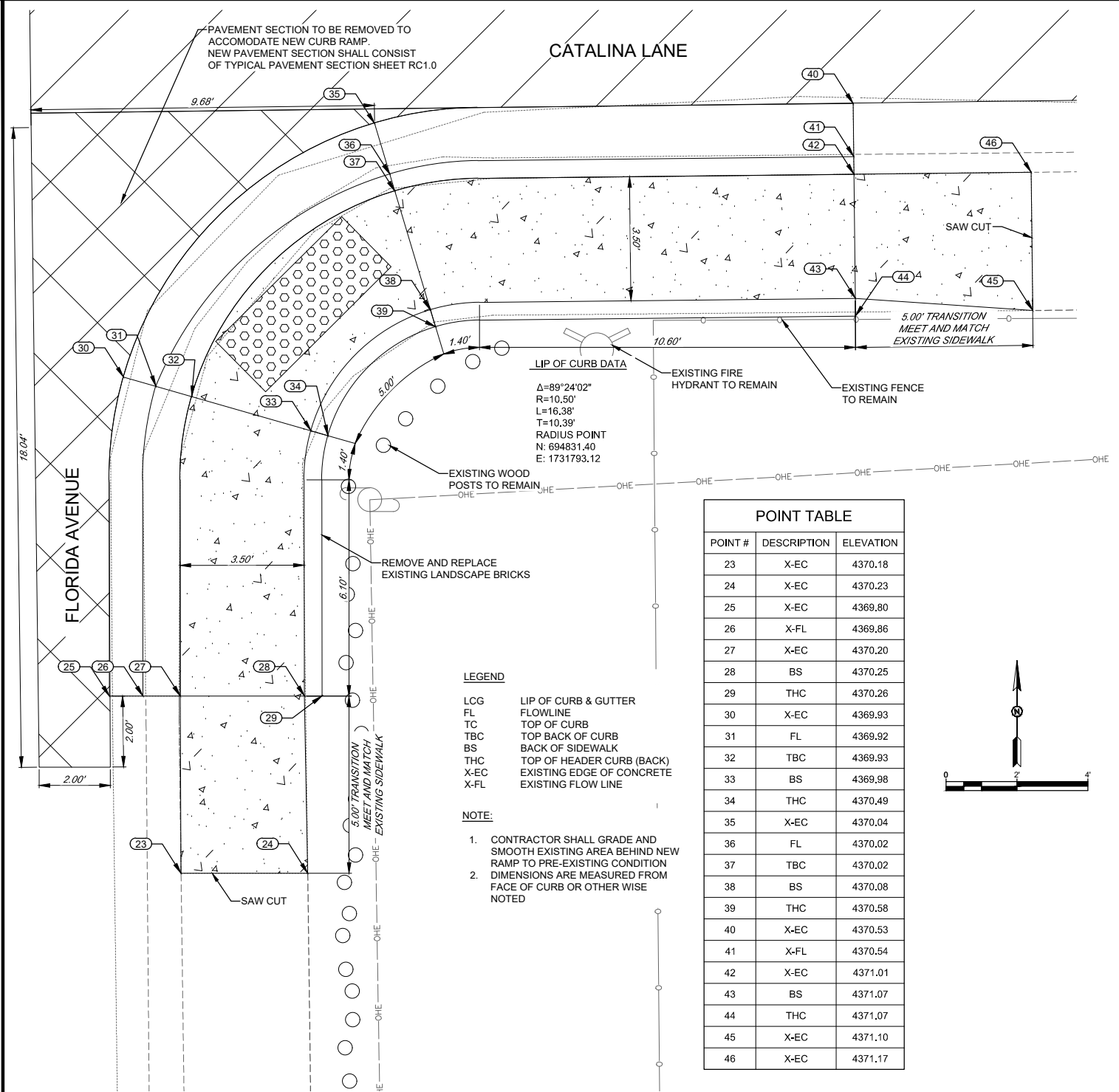

POINT TABLE		
POINT #	DESCRIPTION	ELEVATION
23	X-EC	4370.18
24	X-EC	4370.23
25	X-EC	4369.80
26	X-FL	4369.86
27	X-EC	4370.20
28	BS	4370.25
29	THC	4370.26
30	X-EC	4369.93
31	FL	4369.92
32	TBC	4369.93
33	BS	4369.98
34	THC	4370.49
35	X-EC	4370.04
36	FL	4370.02
37	TBC	4370.02
38	BS	4370.08
39	THC	4370.58
40	X-EC	4370.53
41	X-FL	4370.54
42	X-EC	4371.01
43	BS	4371.07
44	THC	4371.07
45	X-EC	4371.10
46	X-EC	4371.17

LEGEND

- LCG LIP OF CURB & GUTTER
- FL FLOWLINE
- TC TOP OF CURB
- TBC TOP BACK OF CURB
- BS BACK OF SIDEWALK
- THC TOP OF HEADER CURB (BACK)
- X-EC EXISTING EDGE OF CONCRETE
- X-FL EXISTING FLOW LINE

NOTE:

1. CONTRACTOR SHALL GRADE AND SMOOTH EXISTING AREA BEHIND NEW RAMP TO PRE-EXISTING CONDITION
2. DIMENSIONS ARE MEASURED FROM FACE OF CURB OR OTHER WISE NOTED

CATALINA LANE & FLORIDA AVENUE CURB RAMP SOUTHEAST

REV. No.	DATE	DESCRIPTION	APPROVED

New Mexico One Call, Inc. Call 2 days before you dig!
NMOC Dial 811 or 1-800-321-2537
 Professional Resources for Damage Prevention

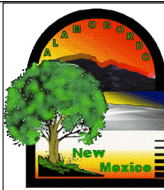

Street Maintenance Program FY2018
CATALINA LANE & FLORIDA AVENUE RAMP DETAILS
 CITY OF ALAMOGORDO, NEW MEXICO, ENGINEERING DEPARTMENT

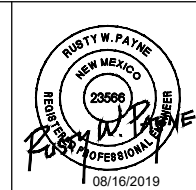

SMITH ENGINEERING
 Solutions for Today... Vision for Tomorrow
 201 N Church Street Suite 200A Las Cruces, NM 88001 Phone: 575-523-2395 www.smithengineering.pro

Public Works Bid No.: 2019-002	Sheet No.:
Drawn By: MM	Designed By: MM
Checked By: RP	Approved By: COA
Scale: Horiz.: n/a Vert.: n/a	
HORIZ. BAR SCALE	
INCLUDE VERT SCALE ON P&P	

Sheet No.: **GD9.0**
 Sheet 28 of 49
 EN1803

POINT #	DESCRIPTION	ELEVATION
1	X-EC	4373.83
2	X-EC	4373.99
3	X-EC	4373.56
4	X-FL	4373.70
5	X-EC	4373.89
6	BS	4373.95
7	THC	4373.96
8	X-EC	4373.72
9	FL	4373.70
10	TBC	4373.71
11	BS	4373.77
12	THC	4374.28
13	X-EC	4373.82
14	FL	4373.80
15	TBC	4373.82
16	BS	4373.87
17	THC	4374.37

POINT #	DESCRIPTION	ELEVATION
18	X-EC	4373.90
19	X-FL	4373.88
20	X-EC	4374.21
21	BS	4374.26
22	THC	4374.27
23	X-EC	4374.21
24	X-EC	4374.36

LEGEND

LCG LIP OF CURB & GUTTER
 FL FLOWLINE
 TC TOP OF CURB
 TBC TOP BACK OF CURB
 BS BACK OF SIDEWALK
 THC TOP OF HEADER CURB (BACK)
 X-EC EXISTING EDGE OF CONCRETE
 X-FL EXISTING FLOW LINE

NOTE:

- CONTRACTOR SHALL GRADE AND SMOOTH EXISTING AREA BEHIND NEW RAMP TO PRE-EXISTING CONDITION
- DIMENSIONS ARE MEASURED FROM FACE OF CURB OR OTHER WISE NOTED

LIP OF CURB DATA

$\Delta=90^{\circ}26'42"$
 $R=7.00'$
 $L=11.05'$
 $T=7.05'$
 RADIUS POINT
 N: 694879.05
 E: 1732070.25

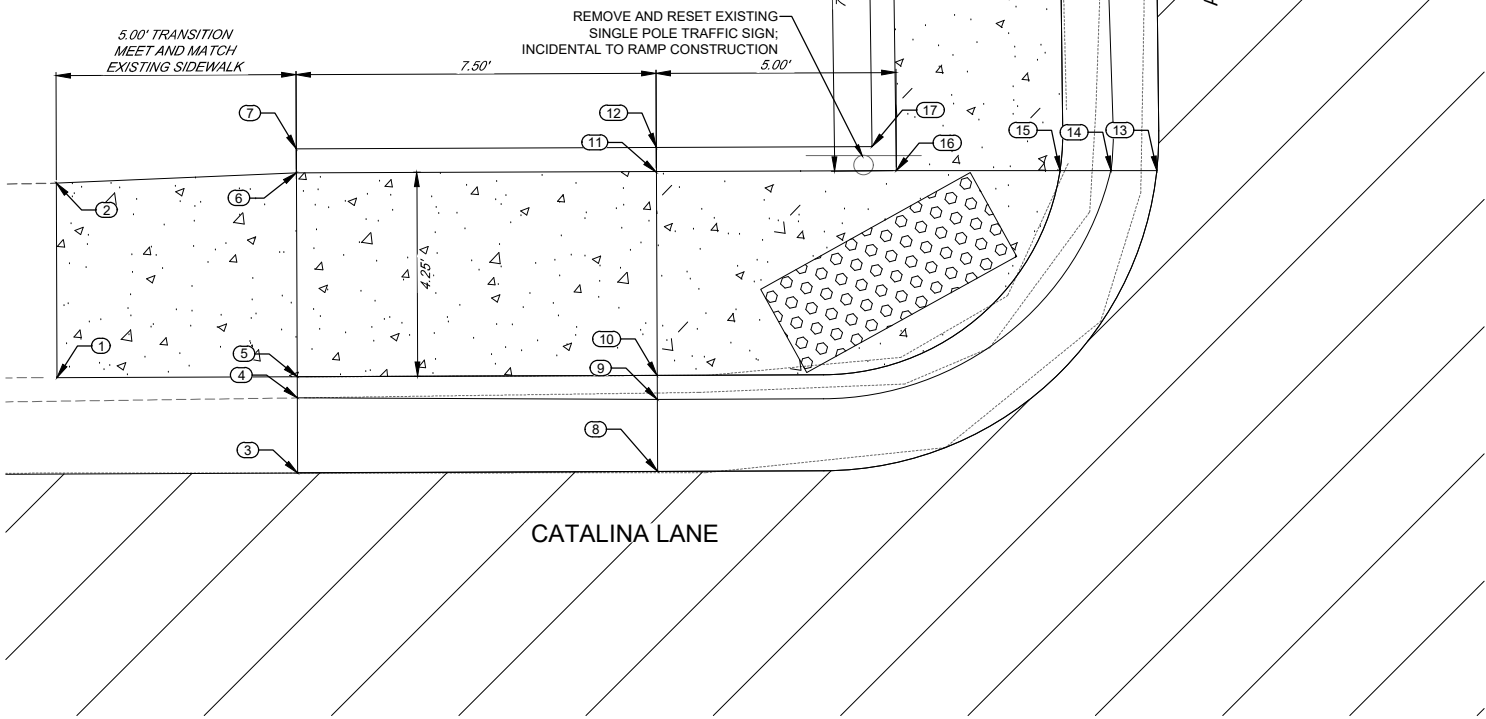

**CATALINA LANE & ALASKA AVENUE
CURB RAMP NORTHWEST**

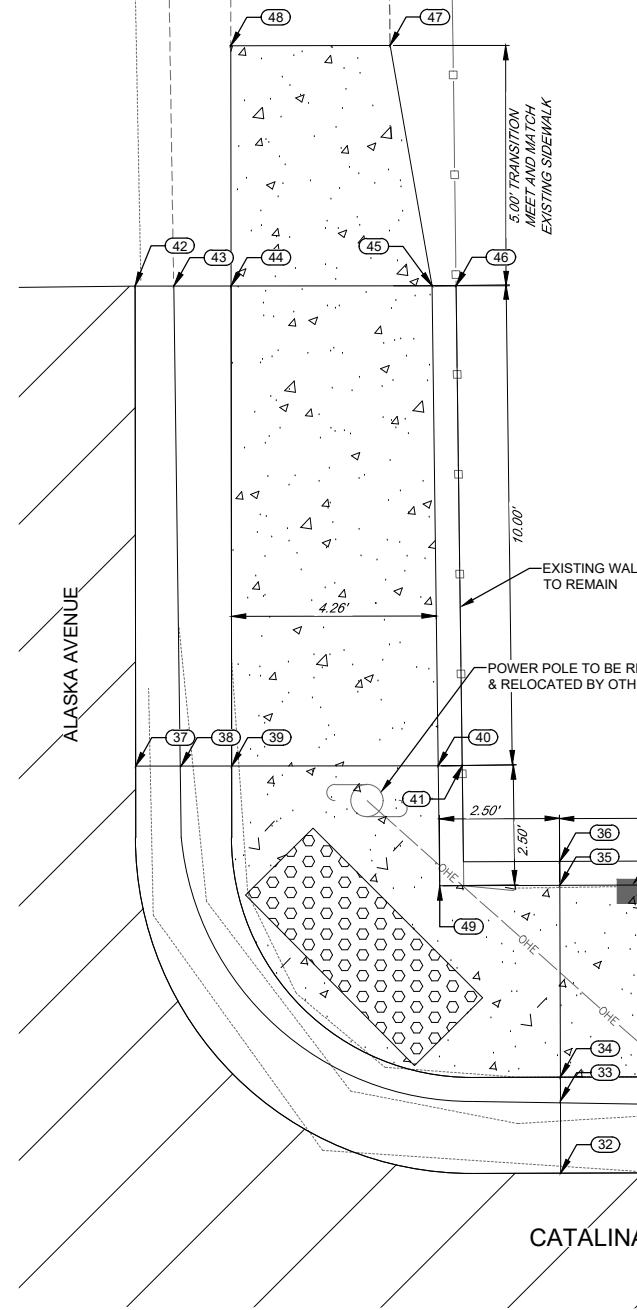

**CATALINA LANE & ALASKA AVENUE
CURB RAMP NORTHEAST**

POINT #	DESCRIPTION	ELEVATION
25	X-EC	4374.68
26	X-EC	4374.64
27	X-EC	4374.16
28	X-FL	4374.10
29	X-EC	4374.65
30	BS	4374.71
31	THC	4374.72
32	X-EC	4374.11
33	FL	4374.08
34	TBC	4374.09
35	BS	4374.15
36	THC	4374.66
37	X-EC	4374.18
38	FL	4374.16
39	TBC	4374.18
40	BS	4374.24
41	THC	4374.75
42	X-EC	4374.25
43	X-FL	4374.27

POINT #	DESCRIPTION	ELEVATION
44	X-EC	4374.62
45	BS	4374.68
46	THC	4374.69
47	X-EC	4374.72
48	X-EC	4374.62
49	BS	4374.20

LEGEND

LCG LIP OF CURB & GUTTER
 FL FLOWLINE
 TC TOP OF CURB
 TBC TOP BACK OF CURB
 BS BACK OF SIDEWALK
 THC TOP OF HEADER CURB (BACK)
 X-EC EXISTING EDGE OF CONCRETE

NOTE:

- CONTRACTOR SHALL GRADE AND SMOOTH EXISTING AREA BEHIND NEW RAMP TO PRE-EXISTING CONDITION
- DIMENSIONS ARE MEASURED FROM FACE OF CURB OR OTHER WISE NOTED

LIP OF CURB DATA

$\Delta=90^{\circ}13'20"$
 $R=7.00'$
 $L=11.01'$
 $T=7.02'$
 RADIUS POINT
 N: 694879.99
 E: 1732110.24

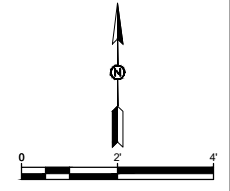

REV. No.	DATE	DESCRIPTION	APPROVED

New Mexico One Call, Inc. Call 2 days before you dig!
NMOC
 Professional Resources for Damage Prevention 1-800-321-2537

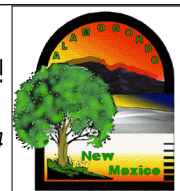

Street Maintenance Program FY2018

CATALINA LANE & ALASKA AVENUE RAMP DETAILS
 CITY OF ALAMOGORDO, NEW MEXICO, ENGINEERING DEPARTMENT

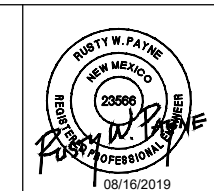

SMITH ENGINEERING
 Solutions for Today... Vision for Tomorrow
 201 N Church Street Suite 200A Las Cruces, NM 88001 Phone: 575-523-2395 www.smithengineering.pro

Public Works Bid No.: 2019-002

Drawn By: MM Designed By: MM
 Checked By: RP Approved By: COA

Scale: Horiz.: n/a Vert.: n/a
 HORIZ. BAR SCALE
 INCLUDE VERT SCALE ON P&P

Sheet No.: **GD10.0**

Sheet 29 of 49

EN1803

POINT TABLE		
POINT #	DESCRIPTION	ELEVATION
1	X-EC	4376.53
2	X-FL	4376.49
3	X-EC	4376.95
4	BS	4377.01
5	THC	4377.02
6	X-EC	4376.72
7	FL	4376.70
8	TBC	4376.71
9	BS	4376.77
10	THC	4377.27
11	X-EC	4376.82
12	FL	4376.80
13	TBC	4376.81
14	BS	4376.87
15	THC	4377.37
16	X-EC	4376.85
17	X-FL	4376.78
18	X-EC	4377.11
19	BS	4377.17
20	THC	4377.18

POINT TABLE		
POINT #	DESCRIPTION	ELEVATION
21	X-EC	4377.10
22	X-EC	4377.23

LEGEND

- LCG LIP OF CURB & GUTTER FLOWLINE
- FL FLOWLINE
- TC TOP OF CURB
- TBC TOP BACK OF CURB
- BS BACK OF SIDEWALK
- THC TOP OF HEADER CURB (BACK)
- X-EC EXISTING EDGE OF CONCRETE
- X-FL EXISTING FLOW LINE

NOTE:

- CONTRACTOR SHALL GRADE AND SMOOTH EXISTING AREA BEHIND NEW RAMP TO PRE-EXISTING CONDITION
- DIMENSIONS ARE MEASURED FROM FACE OF CURB OR OTHERWISE NOTED

LIP OF CURB DATA

Δ=90°12'16"
R=7.00
L=11.02'
T=7.03'
RADIUS POINT
N: 694883.23
E: 1732388.91

CONTRACTOR SHALL REMOVE & RESET EXISTING SINGLE POST SIGN AS NEEDED; INCIDENTAL TO RAMP CONSTRUCTION

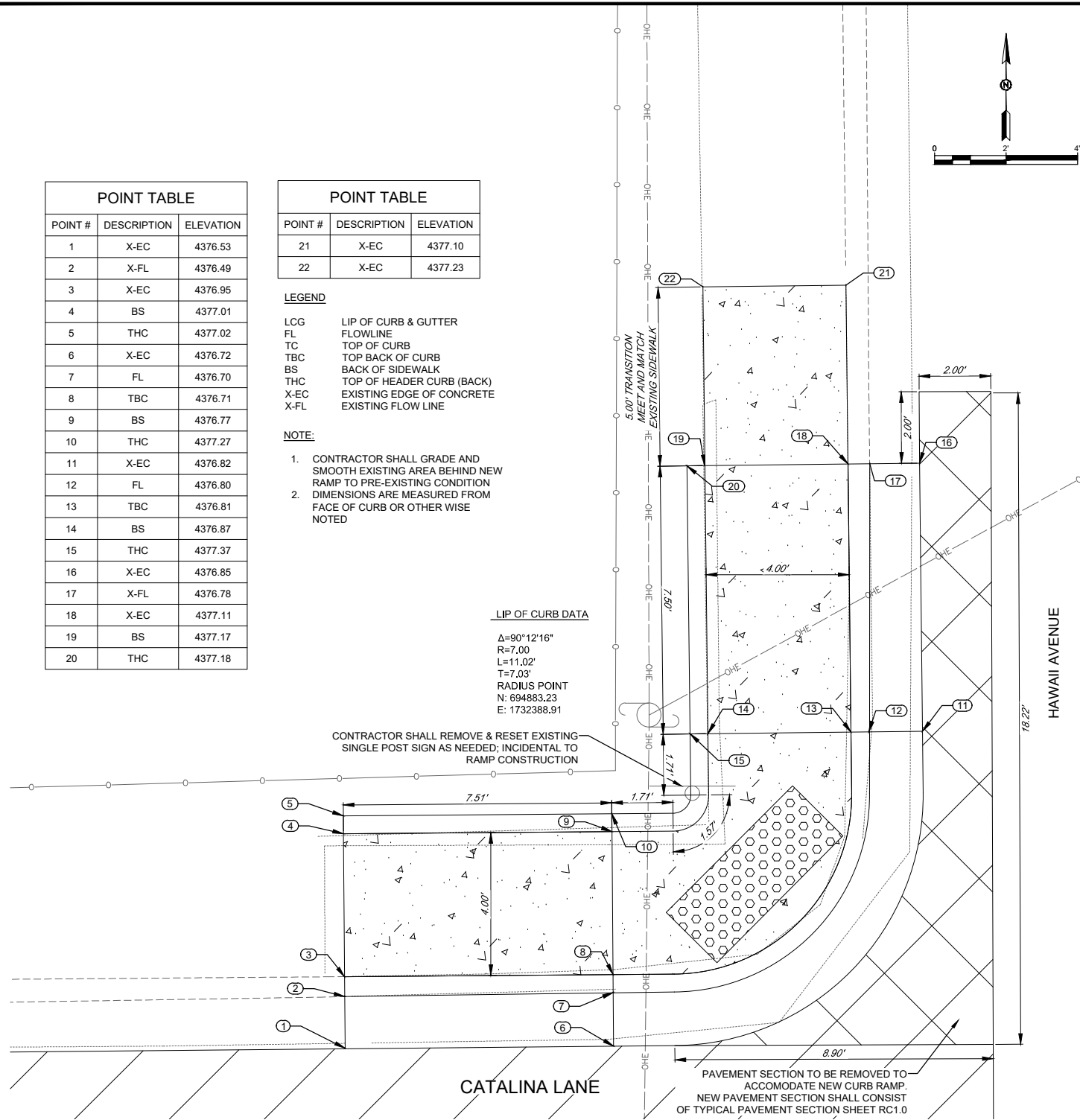

CATALINA LANE & HAWAII AVENUE CURB RAMP NORTHWEST

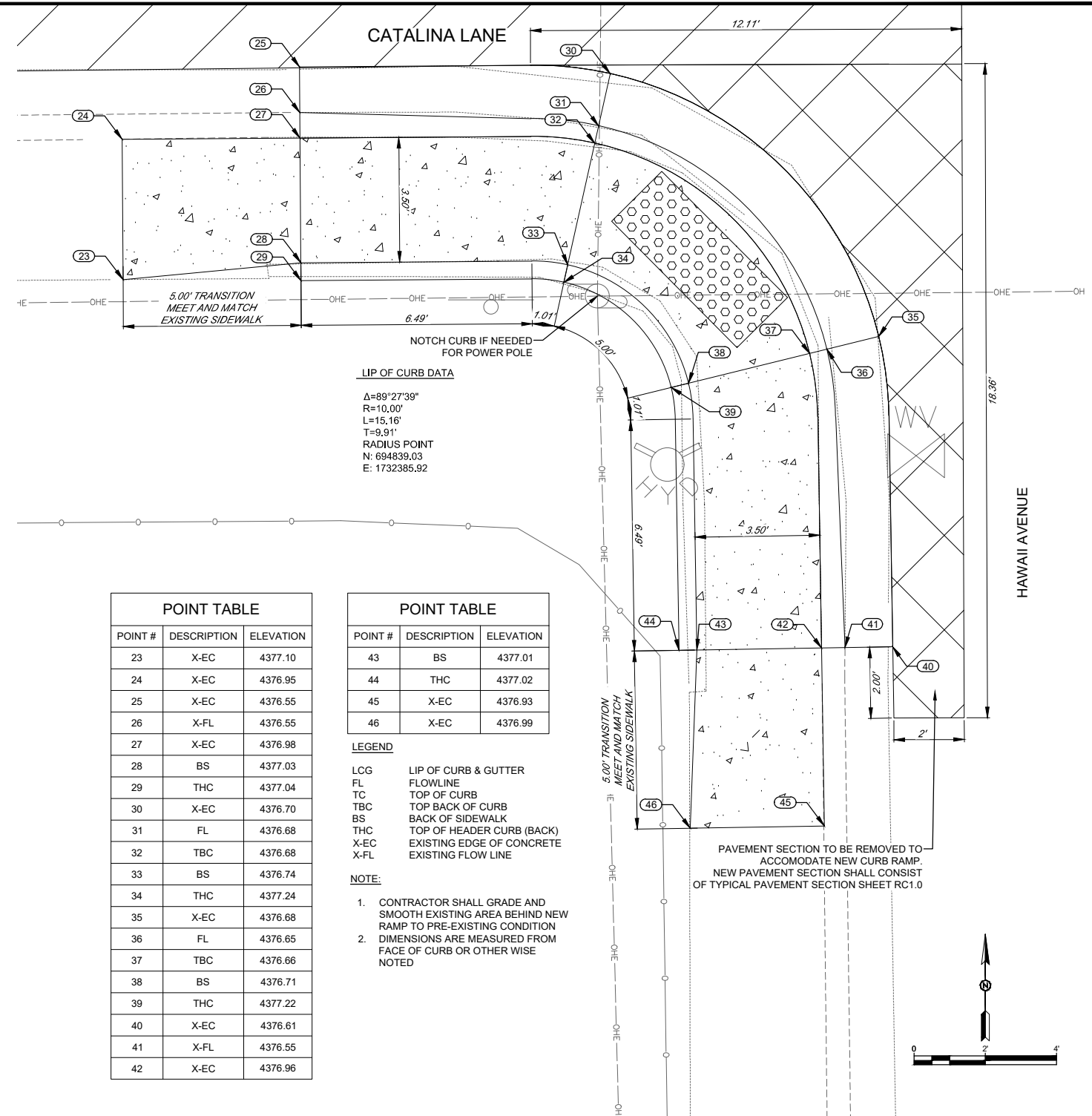

CATALINA LANE & HAWAII AVENUE CURB RAMP SOUTHWEST

POINT TABLE		
POINT #	DESCRIPTION	ELEVATION
23	X-EC	4377.10
24	X-EC	4376.95
25	X-EC	4376.55
26	X-FL	4376.55
27	X-EC	4376.98
28	BS	4377.03
29	THC	4377.04
30	X-EC	4376.70
31	FL	4376.68
32	TBC	4376.68
33	BS	4376.74
34	THC	4377.24
35	X-EC	4376.68
36	FL	4376.65
37	TBC	4376.66
38	BS	4376.71
39	THC	4377.22
40	X-EC	4376.61
41	X-FL	4376.55
42	X-EC	4376.96

POINT TABLE		
POINT #	DESCRIPTION	ELEVATION
43	BS	4377.01
44	THC	4377.02
45	X-EC	4376.93
46	X-EC	4376.99

LEGEND

- LCG LIP OF CURB & GUTTER FLOWLINE
- FL FLOWLINE
- TC TOP OF CURB
- TBC TOP BACK OF CURB
- BS BACK OF SIDEWALK
- THC TOP OF HEADER CURB (BACK)
- X-EC EXISTING EDGE OF CONCRETE
- X-FL EXISTING FLOW LINE

NOTE:

- CONTRACTOR SHALL GRADE AND SMOOTH EXISTING AREA BEHIND NEW RAMP TO PRE-EXISTING CONDITION
- DIMENSIONS ARE MEASURED FROM FACE OF CURB OR OTHERWISE NOTED

LIP OF CURB DATA

Δ=89°27'39"
R=10.00'
L=15.16'
T=9.91'
RADIUS POINT
N: 694839.03
E: 1732385.92

PAVEMENT SECTION TO BE REMOVED TO ACCOMMODATE NEW CURB RAMP. NEW PAVEMENT SECTION SHALL CONSIST OF TYPICAL PAVEMENT SECTION SHEET RC1.0

REV. No.	DATE	DESCRIPTION	APPROVED

New Mexico One Call, Inc. Call 2 days before you dig!
NMOC
 Professional Resources for Damage Prevention 1-800-321-2537
 Dial 811 or 1-800-321-2537

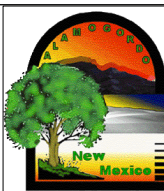

Street Maintenance Program FY2018
CATALINA LANE & HAWAII AVENUE RAMP DETAILS
 CITY OF ALAMOGORDO, NEW MEXICO, ENGINEERING DEPARTMENT

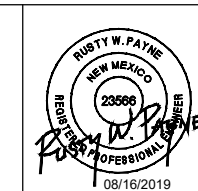

SMITH ENGINEERING
 Solutions for Today... Vision for Tomorrow
 201 N Church Street
 Suite 200A
 Las Cruces, NM 88001
 Phone: 575-523-2395
 www.smithengineering.pro

Public Works Bid No.: 2019-002	Sheet No.:
Drawn By: MM	Designed By: MM
Checked By: RP	Approved By: COA
Scale: Horiz.: n/a Vert.: n/a	
HORIZ. BAR SCALE	
INCLUDE VERT SCALE ON P&P	

Sheet No. **GD11.0**
 Sheet 30 of 49
 EN1803

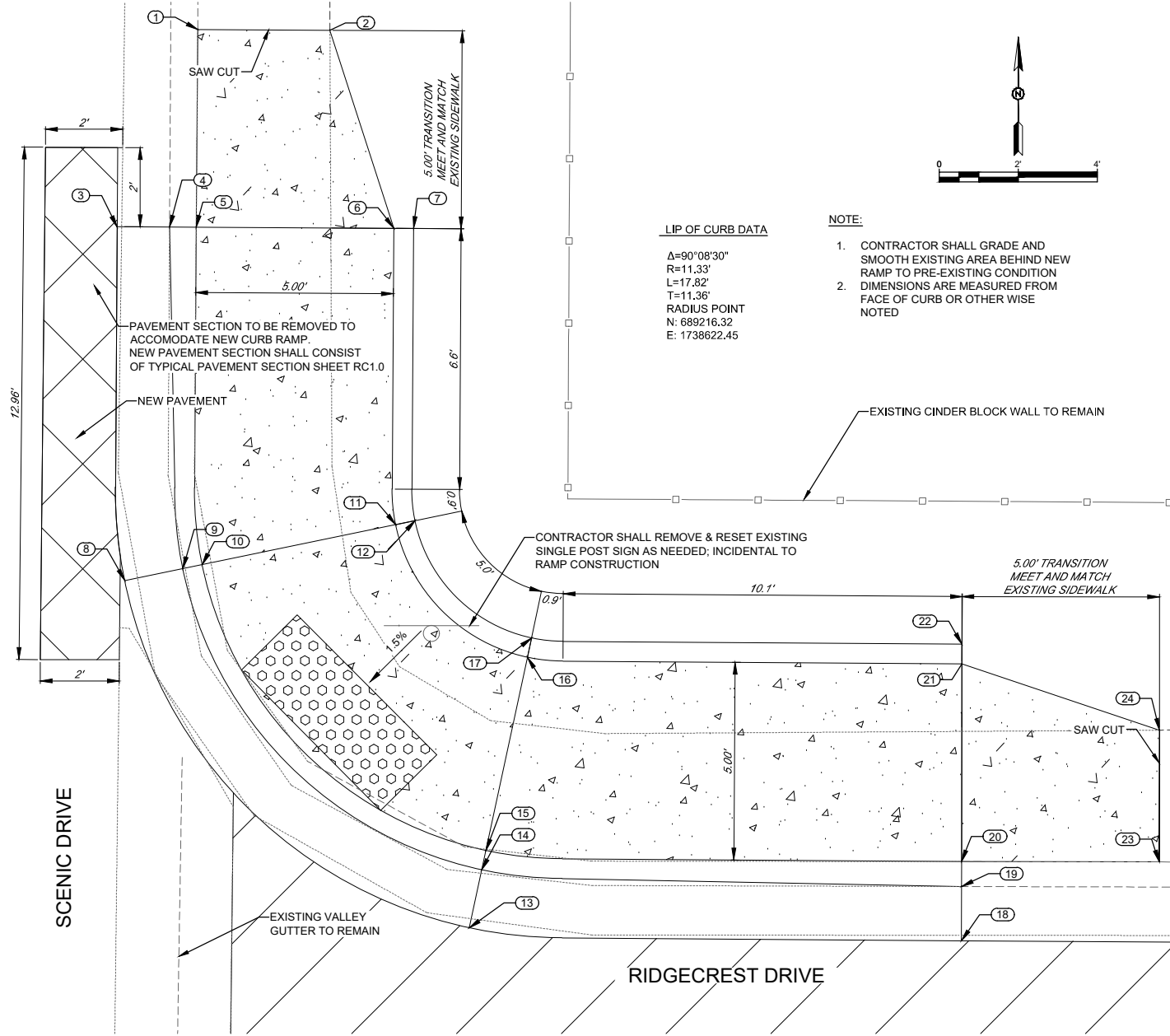

LIP OF CURB DATA
 $\Delta=90^{\circ}08'30''$
 $R=11.33'$
 $L=17.82'$
 $T=11.36'$
 RADIUS POINT
 N: 689216.32
 E: 1738622.45

- NOTE:**
- CONTRACTOR SHALL GRADE AND SMOOTH EXISTING AREA BEHIND NEW RAMP TO PRE-EXISTING CONDITION DIMENSIONS ARE MEASURED FROM FACE OF CURB OR OTHERWISE NOTED
 - CONTRACTOR SHALL REMOVE & RESET EXISTING SINGLE POST SIGN AS NEEDED; INCIDENTAL TO RAMP CONSTRUCTION

**RIDGECREST DRIVE (ABBOTT AVE) & SCENIC DRIVE
 CURB RAMP NORTHEAST**

POINT TABLE			POINT TABLE		
POINT #	DESCRIPTION	ELEVATION	POINT #	DESCRIPTION	ELEVATION
1	X-EC	4484.76	13	X-EC	4484.33
2	X-EC	4484.87	14	FL	4484.31
3	X-EC	4484.30	15	TBC	4484.31
4	X-FL	4484.48	16	BS	4484.39
5	X-EC	4484.76	17	THC	4484.90
6	BS	4484.84	18	X-EC	4484.72
7	THC	4484.87	19	X-FL	4484.73
8	X-EC	4484.23	20	X-EC	4485.20
9	FL	4484.21	21	BS	4485.27
10	TBC	4484.22	22	THC	4485.28
11	BS	4484.29	23	X-EC	4485.36
12	THC	4484.80	24	X-EC	4485.50

- LEGEND**
- LCG LIP OF CURB & GUTTER
 - FL FLOWLINE
 - TC TOP OF CURB
 - TBC TOP BACK OF CURB
 - BS BACK OF SIDEWALK
 - THC TOP OF HEADER CURB (BACK)
 - X-EC EXISTING EDGE OF CONCRETE
 - X-FL EXISTING FLOW LINE

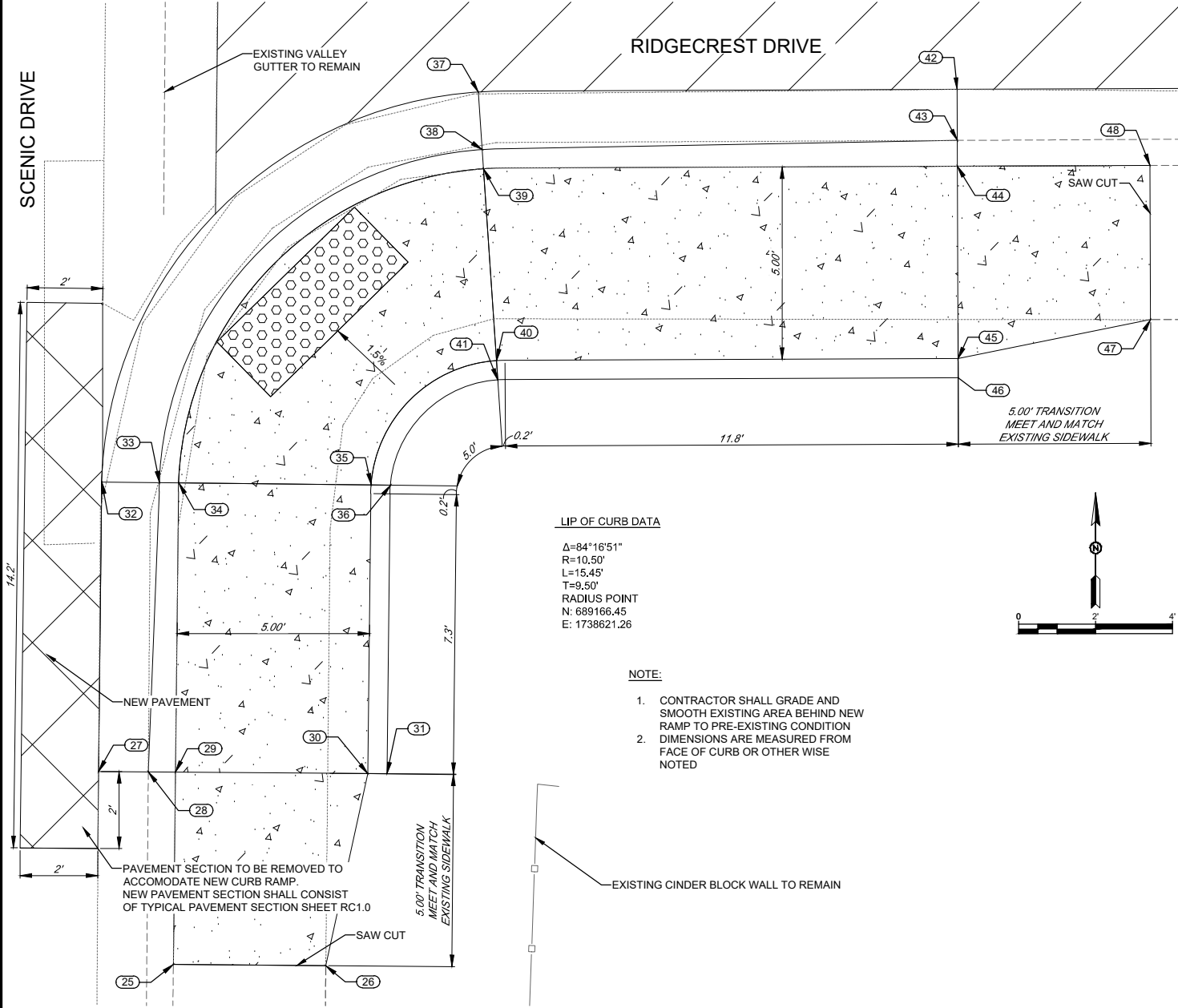

LIP OF CURB DATA
 $\Delta=84^{\circ}16'51''$
 $R=10.50'$
 $L=15.45'$
 $T=9.50'$
 RADIUS POINT
 N: 689166.45
 E: 1738621.26

- NOTE:**
- CONTRACTOR SHALL GRADE AND SMOOTH EXISTING AREA BEHIND NEW RAMP TO PRE-EXISTING CONDITION DIMENSIONS ARE MEASURED FROM FACE OF CURB OR OTHERWISE NOTED
 - CONTRACTOR SHALL REMOVE & RESET EXISTING SINGLE POST SIGN AS NEEDED; INCIDENTAL TO RAMP CONSTRUCTION

**RIDGECREST DRIVE (ABBOTT AVE) & SCENIC DRIVE
 CURB RAMP SOUTHEAST**

POINT TABLE			POINT TABLE		
POINT #	DESCRIPTION	ELEVATION	POINT #	DESCRIPTION	ELEVATION
25	X-EC	4484.57	37	X-EC	4484.18
26	X-EC	4484.70	38	FL	4484.16
27	X-EC	4484.11	39	TBC	4484.16
28	FL	4484.09	40	BS	4484.24
29	TBC	4484.59	41	THC	4484.75
30	BS	4484.67	42	X-EC	4484.66
31	THC	4484.67	43	FL	4484.70
32	X-EC	4484.13	44	TBC	4485.14
33	FL	4484.10	45	BS	4485.22
34	TBC	4484.11	46	THC	4485.22
35	BS	4484.19	47	X-EC	4485.43
36	THC	4484.69	48	X-EC	4485.26

- LEGEND**
- LCG LIP OF CURB & GUTTER
 - FL FLOWLINE
 - TC TOP OF CURB
 - TBC TOP BACK OF CURB
 - BS BACK OF SIDEWALK
 - THC TOP OF HEADER CURB (BACK)
 - X-EC EXISTING EDGE OF CONCRETE
 - X-FL EXISTING FLOW LINE

REV. No.	DATE	DESCRIPTION	APPROVED

New Mexico One Call, Inc. Call 2 days before you dig!
NMOC Dial 811 or 1-800-321-2537
 Professional Resources for Damage Prevention



Street Maintenance Program FY2018
RIDGECREST DRIVE & SCENIC DRIVE RAMP DETAILS
 CITY OF ALAMOGORDO, NEW MEXICO, ENGINEERING DEPARTMENT

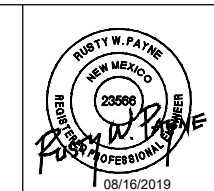

SMITH ENGINEERING
 Solutions for Today... Vision for Tomorrow
 201 N Church Street Suite 200A Las Cruces, NM 88001 Phone: 575-523-2395 www.smithengineering.pro

Public Works Bid No.: 2019-002
 Drawn By: MM Designed By: MM
 Checked By: RP Approved By: COA
 Scale: Horiz.: n/a Vert.: n/a
 HORIZ. BAR SCALE
 INCLUDE VERT SCALE ON P&P

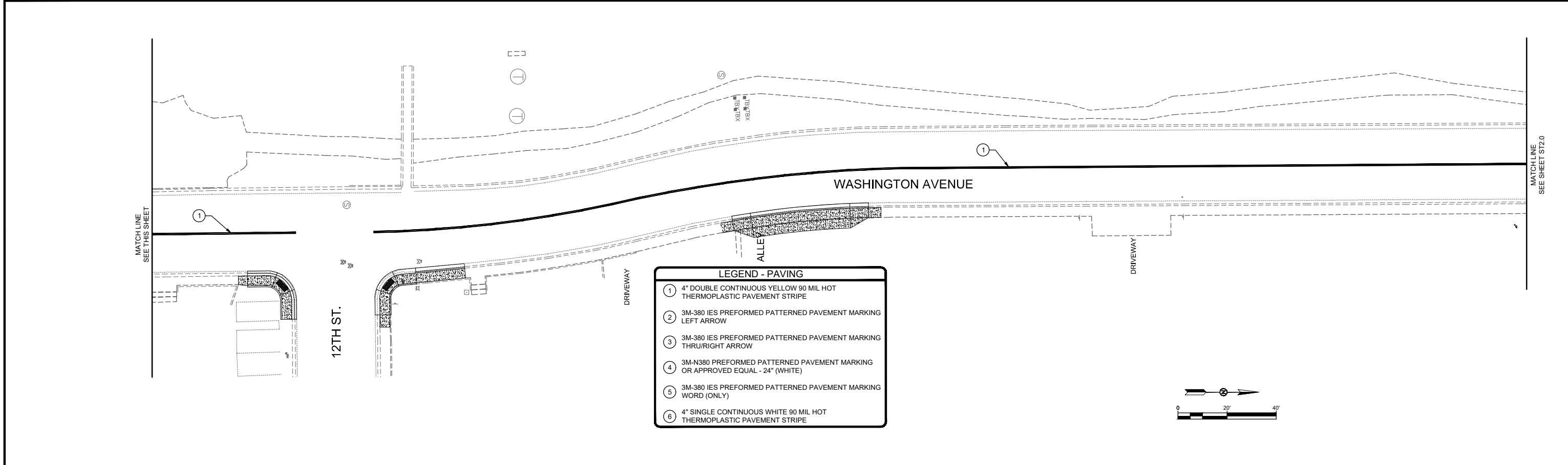
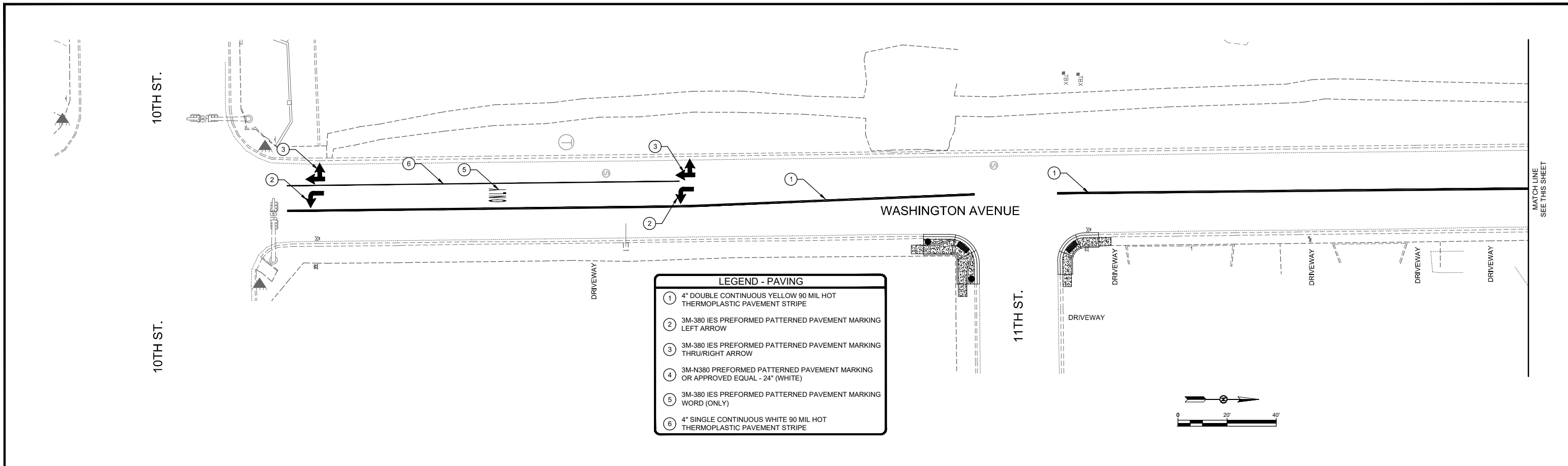

REV. No.	DATE	DESCRIPTION	APPROVED

New Mexico One Call, Inc. Call 2 days before you dig!
NMOC Dial 811 or 1-800-321-2537
 Professional Resources for Damage Prevention



Street Maintenance Program FY2018

WASHINGTON AVENUE STRIPING PLAN

CITY OF ALAMOGORDO, NEW MEXICO, ENGINEERING DEPARTMENT

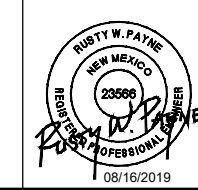

SMITH ENGINEERING
 Solutions for Today...
 Vision for Tomorrow
 201 N Church Street
 Suite 200A
 Las Cruces, NM 88001
 Phone: 575-523-2395
 www.smithengineering.pro

Public Works Bid No.: 2019-002	Sheet No.:
Drawn By: MM Designed By: MM	ST1.0
Checked By: RP Approved By: COA	Sheet 32 of 49
Scale: Horiz.: n/a Vert.: n/a	EN1803
HORIZ. BAR SCALE	
INCLUDE VERT SCALE ON P&P	

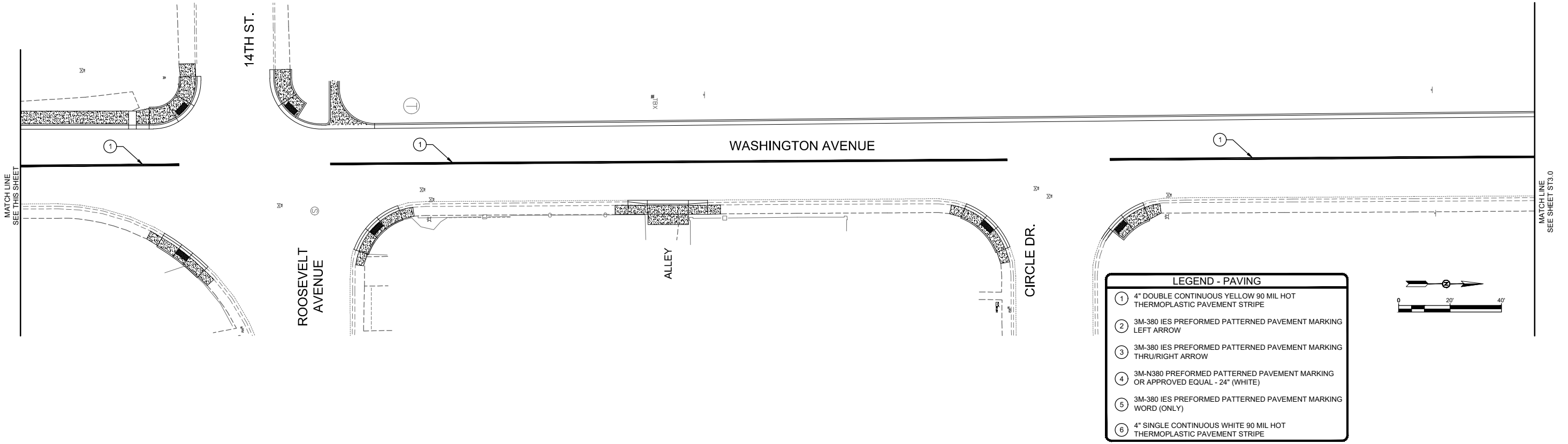
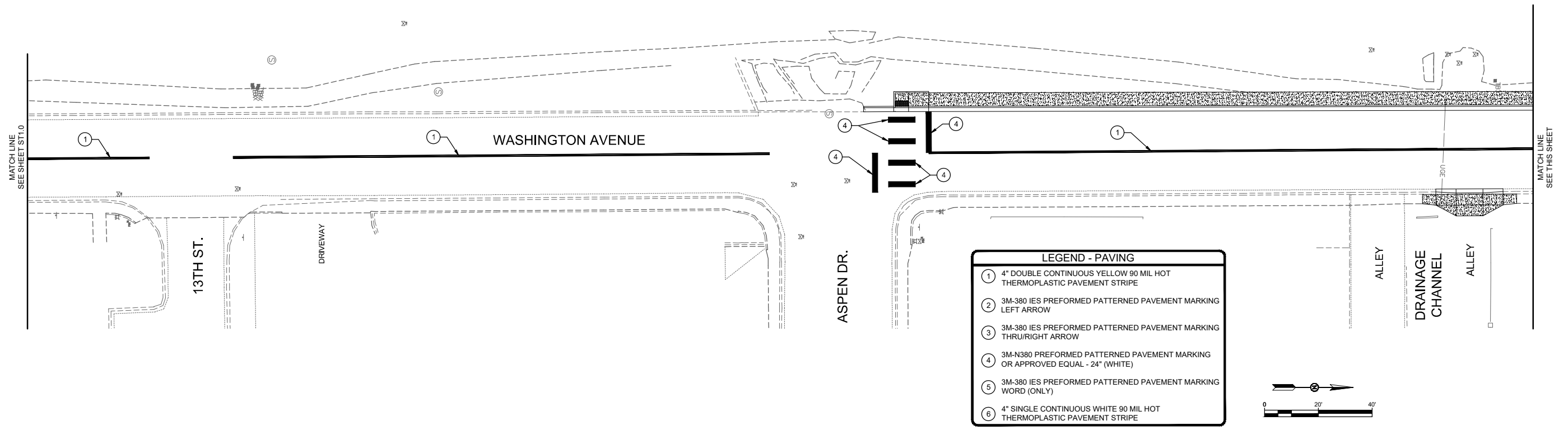

REV. No.	DATE	DESCRIPTION	APPROVED

New Mexico One Call, Inc. Call 2 days before you dig!
NMOC
 Professional Resources for Damage Prevention 1-800-321-2537
 Dial 811 or 1-800-321-2537



Street Maintenance Program FY2018

WASHINGTON AVENUE STRIPING PLAN

CITY OF ALAMOGORDO, NEW MEXICO, ENGINEERING DEPARTMENT

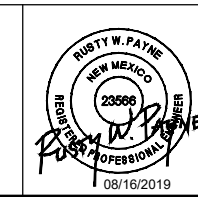

SMITH ENGINEERING
 Solutions for Today...
 Vision for Tomorrow
 281 N Church Street
 Suite 200A
 Las Cruces, NM 88001
 Phone: 575-523-2395
 www.smithengineering.pro

Public Works Bid No.: 2019-002
Drawn By: MM Designed By: MM
Checked By: RP Approved By: COA
Scale: Horiz.: n/a Vert.: n/a
HORIZ. BAR SCALE
INCLUDE VERT SCALE ON P&P

Sheet No.:	ST2.0
Sheet 33 of 49	EN1803

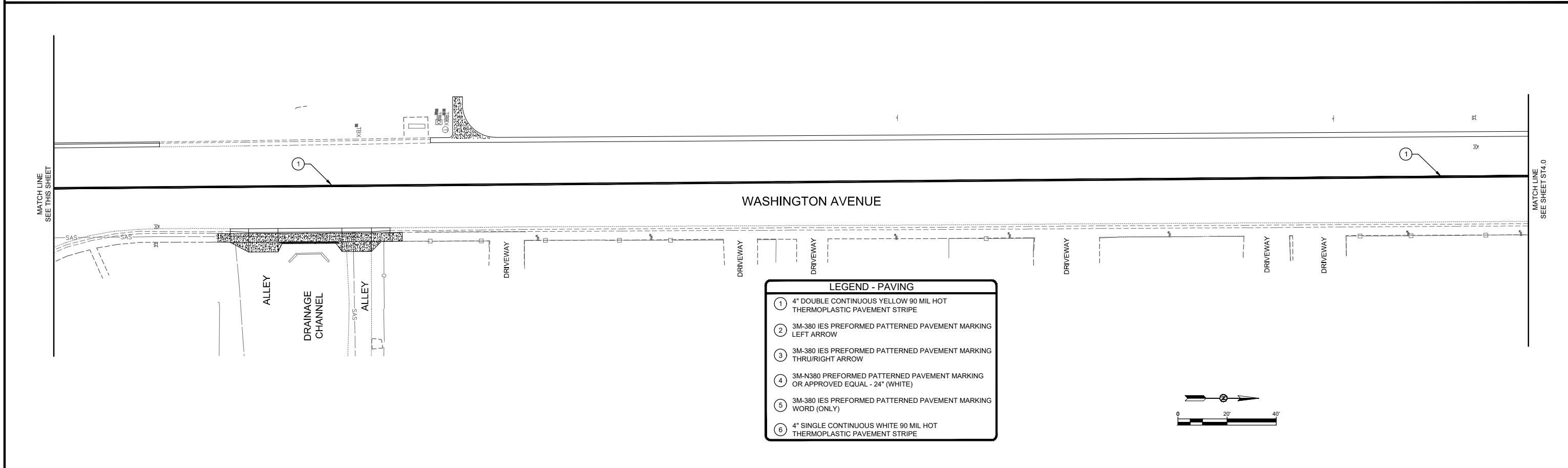
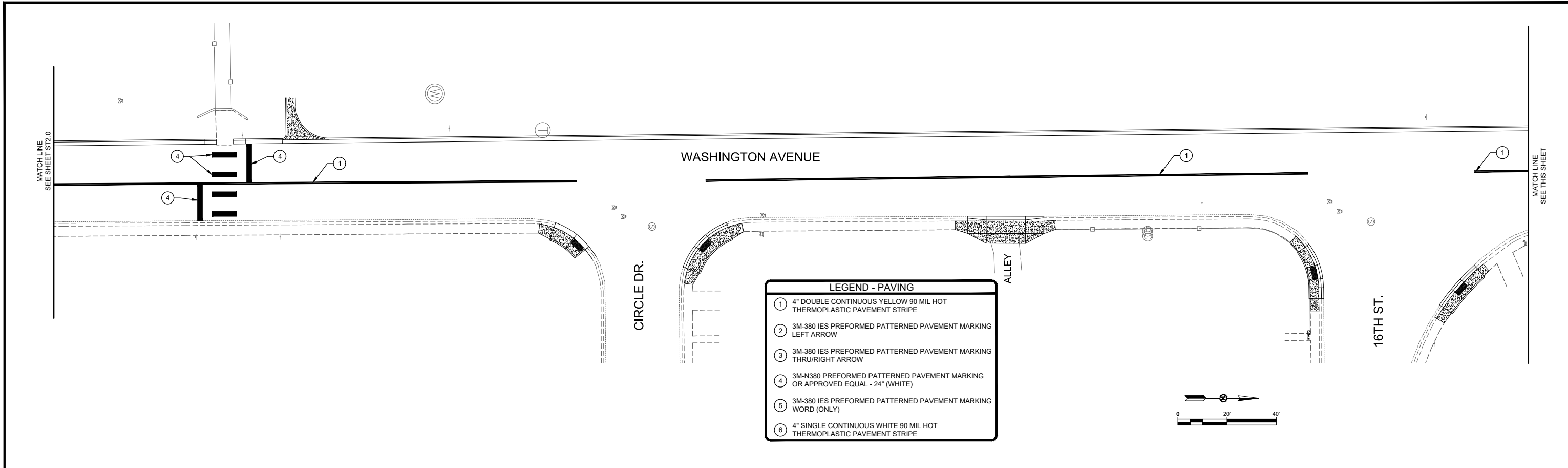

REV. No.	DATE	DESCRIPTION	APPROVED

New Mexico One Call, Inc. Call 2 days before you dig!
NMOC Dial 811 or 1-800-321-2537
 Professional Resources for Damage Prevention



Street Maintenance Program FY2018

WASHINGTON AVENUE STRIPING PLAN

CITY OF ALAMOGORDO, NEW MEXICO, ENGINEERING DEPARTMENT

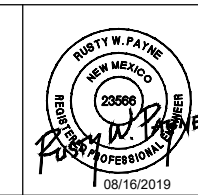

SMITH ENGINEERING
 Solutions for Today...
 Vision for Tomorrow
 281 N Church Street
 Suite 200A
 Las Cruces, NM 88001
 Phone: 575-523-2395
 www.smithengineering.pro

Public Works Bid No.: 2019-002	Sheet No.:
Drawn By: MM Designed By: MM	ST3.0
Checked By: RP Approved By: COA	Sheet 34 of 49
Scale: Horiz.: n/a Vert.: n/a	EN1803
HORIZ. BAR SCALE INCLUDE VERT SCALE ON P&P	

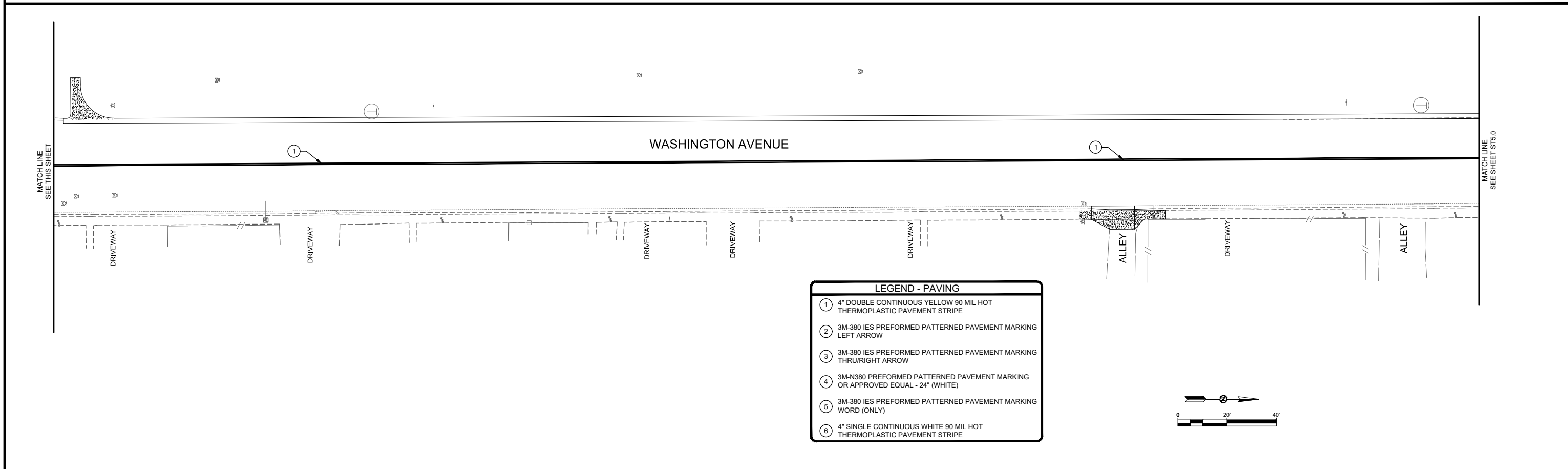
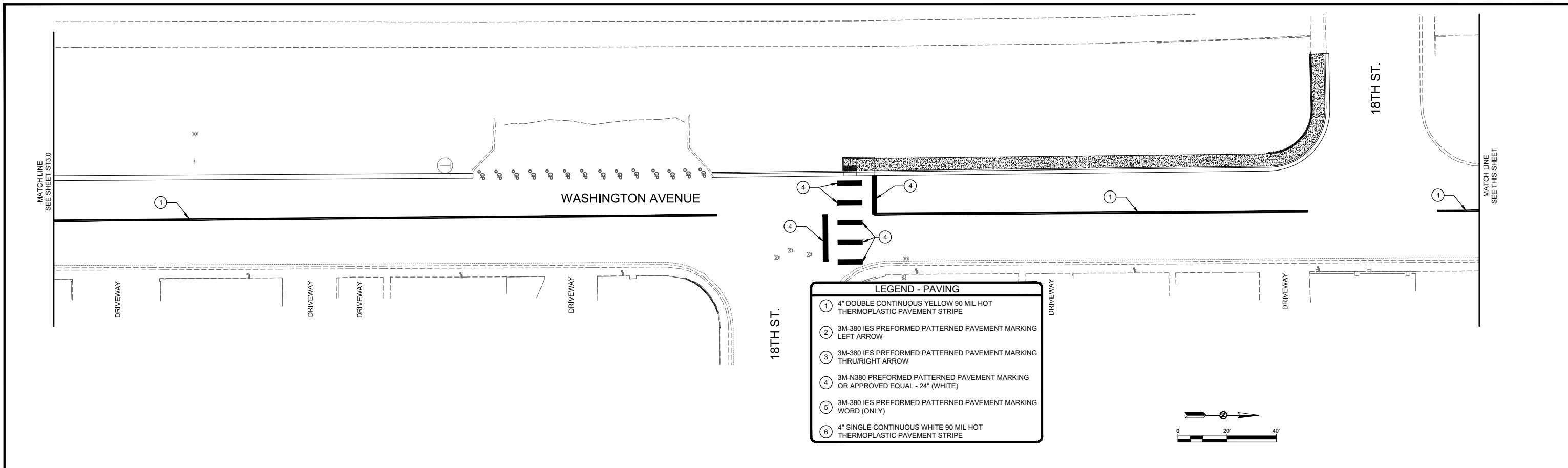

REV. No.	DATE	DESCRIPTION	APPROVED

New Mexico One Call, Inc. Call 2 days before you dig!
NMOC Dial 811 or 1-800-321-2537
 Professional Resources for Damage Prevention



Street Maintenance Program FY2018

WASHINGTON AVENUE STRIPING PLAN

CITY OF ALAMOGORDO, NEW MEXICO, ENGINEERING DEPARTMENT

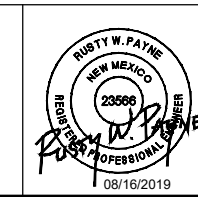

SMITH ENGINEERING
 Solutions for Today...
 Vision for Tomorrow
 201 N Church Street
 Suite 200A
 Las Cruces, NM 88001
 Phone: 575-523-2395
 www.smithengineering.pro

Public Works Bid No.: 2019-002
Drawn By: MM Designed By: MM
Checked By: RP Approved By: COA
Scale: Horiz.: n/a Vert.: n/a HORIZ. BAR SCALE INCLUDE VERT SCALE ON P&P

Sheet No.: ST4.0
Sheet 35 of 49
EN1803

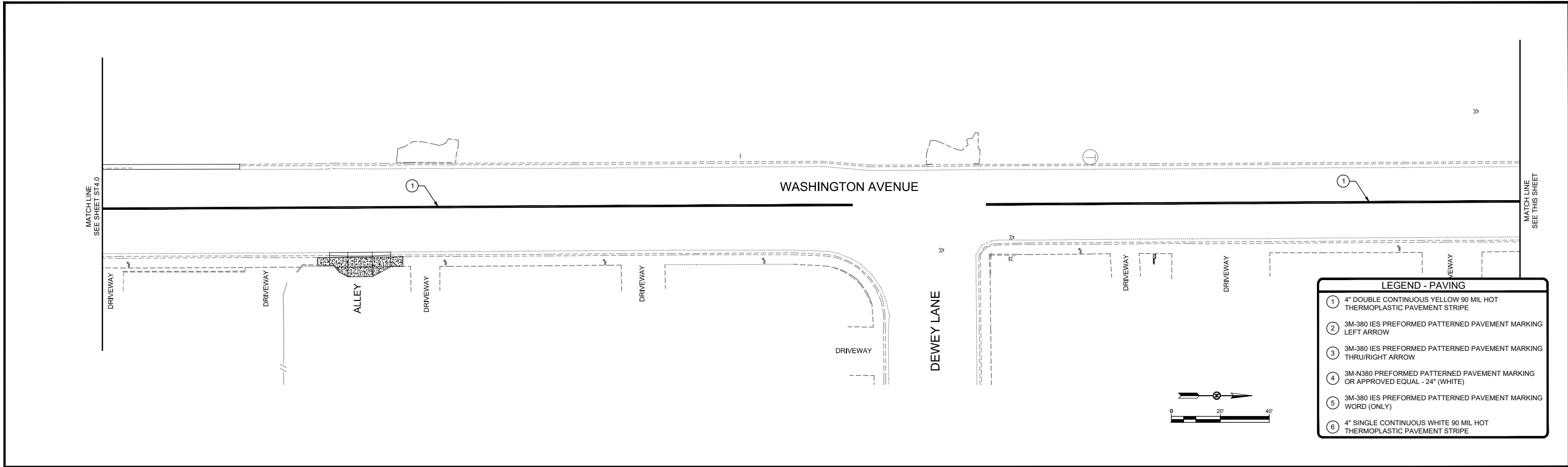

LEGEND - PAVING	
①	4" DOUBLE CONTINUOUS YELLOW 90 MIL HOT THERMOPLASTIC PAVEMENT STRIPE
②	3M-380 IES PREFORMED PATTERNED PAVEMENT MARKING LEFT ARROW
③	3M-380 IES PREFORMED PATTERNED PAVEMENT MARKING THRU/RIGHT ARROW
④	3M-N380 PREFORMED PATTERNED PAVEMENT MARKING OR APPROVED EQUAL - 24" (WHITE)
⑤	3M-380 IES PREFORMED PATTERNED PAVEMENT MARKING WORD (ONLY)
⑥	4" SINGLE CONTINUOUS WHITE 90 MIL HOT THERMOPLASTIC PAVEMENT STRIPE

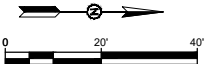
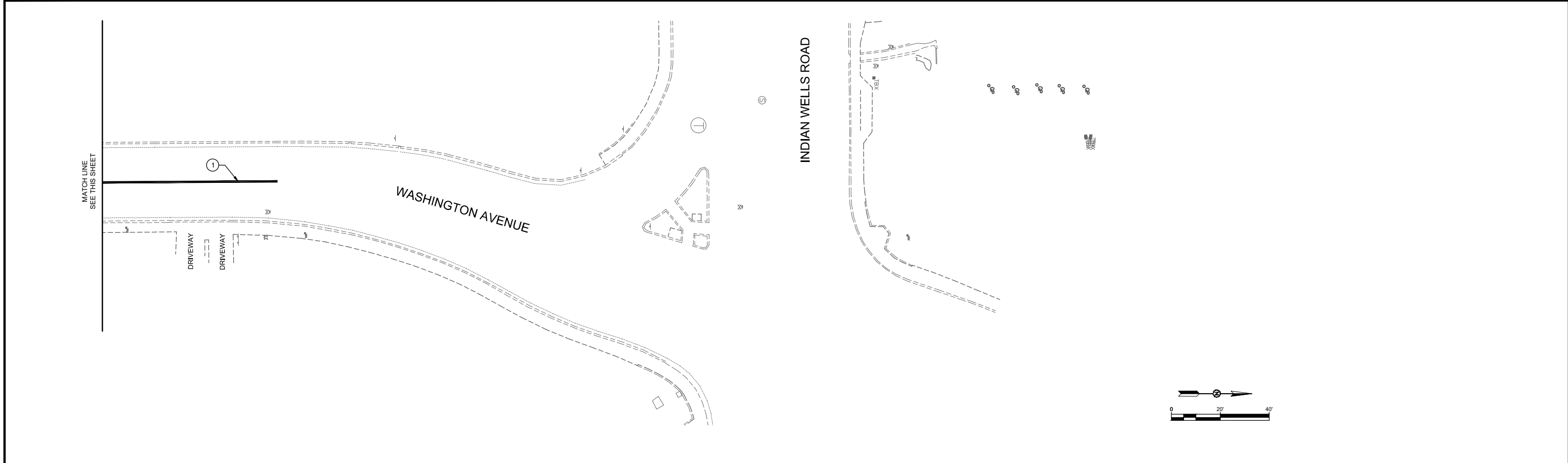
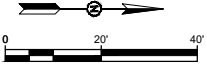

REV. No.	DATE	DESCRIPTION	APPROVED

New Mexico One Call, Inc. Call 2 days before you dig!
NMOC Dial 811 or 1-800-321-2537
 Professional Resources for Damage Prevention



Street Maintenance Program FY2018

WASHINGTON AVENUE STRIPING PLAN

CITY OF ALAMOGORDO, NEW MEXICO, ENGINEERING DEPARTMENT

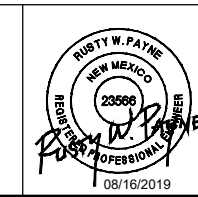

SMITH ENGINEERING
 Solutions for Today...
 Vision for Tomorrow
 281 N Church Street
 Suite 200A
 Las Cruces, NM 88001
 Phone: 575-523-2395
 www.smithengineering.pro

Public Works Bid No.: 2019-002
Drawn By: MM Designed By: MM
Checked By: RP Approved By: COA
Scale: Horiz.: n/a Vert.: n/a HORIZ. BAR SCALE INCLUDE VERT SCALE ON P&P

Sheet No.: ST5.0
Sheet 36 of 49
EN1803

TYPICAL WATER SERVICE INSTALLATION MATERIAL LISTING:

COLD WATER METER: WATER METERS SHALL BE MULTIJET, READING IN CUBIC FEET AND ACCEPTABLE FOR USE WITH ZENNER STEALTH READER MIU SYSTEM. NO SUBSTITUTIONS. REFER TO ARTICLE 02-026.1 WATER SUPPLY SYSTEM FOR THE LIST OF COMPATIBLE WATER METERS. WATER METERS LARGER THAN 2-INCHES SHALL BE POSITIVE DISPLACEMENT (COMPOUND) METERS.

SERVICE (TAPPING) SADDLE: TAPPING SADDLES REQUIRE THE PRE-APPROVAL BY PUBLIC WORKS DEPARTMENT AND ENGINEERING DEPARTMENT PRIOR TO INSTALLATION. ACCEPTABLE SADDLES SHALL HAVE DOUBLE STRAPS STRAP SECURED BY FOUR BOLTS. SADDLES SHALL ALSO HAVE 1" IP THREADED OUTLET AND BE MADE OF THE FOLLOWING ACCEPTED MATERIALS:

BODY - DUCTILE IRON BODY, CONFORMING TO ASTM A-536, WITH 10-12 MIL FUSION EPOXY COATING OR NYLON COATED.

STRAPS - TYPE 304 (18-8) HEAVY GRADE STAINLESS STEEL, CONFORMING TO ASTM A-240.

NUTS & WASHERS - UNC ROLL THREAD TYPE 304 (18-8) STAINLESS STEEL BOLTS WITH HEAVY HEX NUTS. ROD FOR BOLTS, CONFORMING TO ASTM A-240, AND NUTS, CONFORMING TO ASTM A-194. ALL WELDS FULLY PASSIVATED FOR ENHANCED CORROSION RESISTANCE. NUTS COATED TO PREVENT GALLING.

GASKET - NITRILE BUTADIENE RUBBER (NBR), ASTM D-2000 MBC-610 OR HD EDPM O-RING.

NOTE: SADDLE WITH SLENDER SINGLE STRAPS SECURED BY TWO BOLTS. CAST IRON BODY AND STEEL STRAPS ARE NOT ACCEPTABLE.

CORPORATION STOP: CORPORATION STOP SHALL BE BALL VALVE TYPE AND RATED FOR 150 P.S.I. (MINIMUM) WORKING PRESSURE. CORPORATION STOP SHALL HAVE A 1" IP THREADED INLET WITH A PACK JOINT CONNECTION FITTING OR MUELLER INSTA-TITE CONNECTION FOR 1" PVC SERVICE LINE.

SERVICE LINE: SERVICE LINE SHALL BE 1" BLUE SDR POLYETHYLENE, 200 PSI, CONFORMING TO ASTM D2737 AND SPECIFIED FOR POTABLE WATER.

CURB STOP: CURB STOP SHALL BE BALL VALVE TYPE AND RATED FOR 150 P.S.I. (MINIMUM) WORKING PRESSURE.

COPPER METER RESETTER: COPPER METER RESETTER (METER YOKE) SHALL BE HORIZONTAL STYLE, 5/8"x3/4" (METER YOKE) BRASS/COPPER WITH LOCK WING STYLE ANGLE METER VALVE ON INLET AND TOP ENTRY ANGLE DUAL CHECK VALVE ON OUTLET WITH BRASS SUPPORT BAR. THE CONNECTIONS FOR METER SHALL BE BRASS SWIREL NUT WITH WIRE SEAL HOLE AND METER SUPPORT LIP. INLET AND OUTLET THREADS SHALL BE METER THREAD. THE CONNECTION TO THE 1" SERVICE LINE SHALL BE MADE WITH AN AY McDONALD 76102 O.A.E. CTS MAC-PAC JOINT/FNPT CURB STOP AND A 3/4"x1" BRASS METER BUSHING. IF A THERMAL-COIL BOX IS UTILIZED THE FOLLOWING MATERIALS SHALL BE USED VERSUS THE METER YOKE:

- POLYBUTYLENE TUBING
- A LOCK WING METER STOP (INLET 3/4")
- A DUAL CHECK VALVE (OUTLET 3/4")
- A 3/4" OUTSIDE METER THREADED INLET
- A 3/4" OUTSIDE METER THREADED OUTLET

METER BOXES: SPECIFICATION IS BASED ON USE OF "DFW PLASTICS, INC." BY DFW PLASTICS, INC., 901 E INDUSTRIAL AVENUE, SAGINAW TX 76131, WITH ATTRIBUTES AS DESCRIBED BELOW. EQUAL PRODUCTS OF OTHER WATER METER CAN MANUFACTURERS MAY BE ACCEPTABLE WHEN PRE-APPROVED BY OWNER. PRE-APPROVED EQUAL, SUBSTITUTIONS UNDER ARTICLE 01-002.4.

THIS PRODUCT IS DESIGNED TO WITHSTAND LOADING IN NON-DELIBERATE AND INCIDENTAL TRAFFIC. NOT TO BE INSTALLED IN ROADWAY. METER PIT LID SHALL BE BLACK AND CONSTRUCTED OUT OF MODIFIED POLYETHYLENE MATERIAL FOR MAXIMUM DURABILITY AND CORROSION RESISTANCE. THE BLACK MATERIAL IS FOR MAXIMUM UV PROTECTION. THE BLACK MATERIAL SHALL BE UNIFORM THROUGHOUT THE METER PIT LID FOR MAXIMUM LONGEVITY AND NOT HAVE A FOAMING AGENT THAT CREATES AIR POCKETS WITHIN THE POLYMER LID.

VERTICAL AND LATERAL LOAD RATING:

- COMPLIANT WITH AASHTO, DESIGN LOAD OF H-10; ASTM C857-16, DESIGN LOAD OF A-8, 8,000 LBS. TRANSFERRED THROUGH A 10" X 10" STEEL PLATE CENTERED IN THE COVER AND BODY.
- COMPLIANT WITH AASHTO, DESIGN LOAD OF H-20; ASTM C857-16, DESIGN LOAD OF A-16, 16,000 LBS. TRANSFERRED THROUGH A 10" X 20" STEEL PLATE CENTERED ON THE COVER AND BODY.
- THIS PRODUCT IS DESIGNED TO WITHSTAND H-10 AND H-20 LOADING IN NON-DELIBERATE OR INCIDENTAL TRAFFIC AREAS.

NOT INTENDED TO BE INSTALLED IN ROADWAYS.

POLYMER LID

- THE POLYMER LID SHALL HAVE A MOLDED KEY HOLE AND PLASTIC LOCK UNDERNEATH LID - AS ILLUSTRATED.
- THE POLYMER LID SHALL HAVE ONE (1) MOLDED SLIDE MOUNT FOR PLACEMENT OF AMR/AMI DEVICE - AS ILLUSTRATED.
- THE POLYMER LID SHALL SEAT SECURELY AND EVENLY INSIDE THE METER PIT AND SHALL NOT OVERLAP THE TOP EDGE OF THE METER PIT.
- THE POLYMER LID SHALL HAVE MOLDED TREAD-PATTERN FOR SKID RESISTANCE - TREAD DIMENSIONS SHALL BE 0.188" X 0.938" X 0.150" DEEP.
- THE POLYMER LID SHALL HAVE "WATER METER" MOLDED INTO THE LID - FONT SHALL BE STD FADAL CNC FONT WITH 1" CHARACTERS X 0.150" DEEP.
- THE POLYMER LID SHALL BE BLACK AND HAVE A MOLDED RECYCLED EMBLEM WITH A MINIMUM OF 50% POST CONSUMER RECYCLED AND 50% POST INDUSTRIAL/ PRE CONSUMER RECYCLED CONTENT - VERIFIED WITH A LEED PRODUCT DOCUMENTATION.

POLYMER BODY

- THE POLYMER BODY SHALL BE BLACK AND HAVE A MINIMUM OF 3/8" WALL THICKNESS - AS ILLUSTRATED.
- THE POLYMER BODY SHALL HAVE MINIMUM INSIDE WORKING ROOM OF (23-1/4") - AS ILLUSTRATED.
- THE POLYMER BODY SHALL HAVE CRUSH RESISTANT RIBBING ALONG THE OUTSIDE OF THE BOX WITH 1-5/8" BASE FOOTING LOCATED AT THE BOTTOM OF THE METER PIT TO HELP ELIMINATE SINKING OR FLOATING ONCE INSTALLED.
- THE POLYMER BODY SHALL HAVE A STRAIGHT WALL DESIGN AND NOT BE FLARED AS TO ALLOW FOR ADJUSTMENT TO GRADE AFTER INSTALLATION.
- THE POLYMER BODY SHALL HAVE ONE PIPE SLOT MOLDED ON EACH END OF THE BODY THAT MEASURES (3" X 5-3/4").
- THE POLYMER BODY SHALL HAVE A MOLDED RECYCLED EMBLEM WITH A MINIMUM OF 35% POST INDUSTRIAL/ PRE CONSUMER RECYCLED CONTENT - VERIFIED WITH A LEED PRODUCT DOCUMENTATION.

WHENEVER IN THE SPECIFICATIONS, ANY PARTICULAR MATERIALS, PROCESS AND/OR EQUIPMENT IS INDICATED OR SPECIFIED BY PATENT, PROPRIETARY, OR BRAND NAME, OR BY NAME OF MANUFACTURER, SUCH WORDING SHALL BE DEEMED TO BE USED FOR THE PURPOSE OF FACILITATING DESCRIPTION OF THE MATERIAL, PROCESS, AND/OR EQUIPMENT DESIRED, AND SHALL BE DEEMED TO BE FOLLOWED BY THE WORDS "OR EQUAL". THE LISTS OF ACCEPTABLE MATERIAL ARE NOT INTENDED TO BE COMPREHENSIVE LISTS, OR IN ANY ORDER OF PREFERENCE. THE BIDDER MAY OFFER ANY MATERIAL, PROCESS, AND/OR EQUIPMENT WHICH COMPLY WITH THE GOVERNING SPECIFICATIONS WHICH THE BIDDER CONSIDERS TO BE EQUIVALENT TO THAT WHICH IS INDICATED OR SPECIFIED.

THE NOTED METER BOX SIZE IS FOR A TYPICAL FOR 3/4" AND 1" WATER SERVICES. METER BOXES FOR WATER SERVICES LARGER THAN 1 1/2" SHALL BE PRE-APPROVED BY THE PUBLIC WORKS DEPARTMENT.

CONTRACTOR NOTE: CONTRACTOR SHALL INSCRIBE A 'W' ON TOP OF CONCRETE CURB (IN-LINE W/ NEW WATER SERVICE) TO INDICATE THE LOCATION OF THE NEW WATER SERVICE LINE.

CONTRACTOR NOTE: THE WATER SERVICE LINE MAY BE PUNCHED UNDERNEATH THE EXISTING CURB AND GUTTER AS LONG AS THE RESULTING HOLE IS LESS THAN 6-INCHES IN THE HORIZONTAL DIRECTION.

CONTRACTOR NOTE: METER CAN SHALL NOT BE INSTALLED IN ACCESSIBLE (ADA) RAMP PAN, SLOPE OR LANDINGS.

CONTRACTOR NOTE: IN SOME CASES THE EXISTING WATER METER IS SURROUNDED BY CONCRETE. ANY DAMAGE BY THE CONTRACTOR TO THE ADJACENT CONCRETE SHALL BE REPLACED AT CONTRACTOR'S EXPENSE.

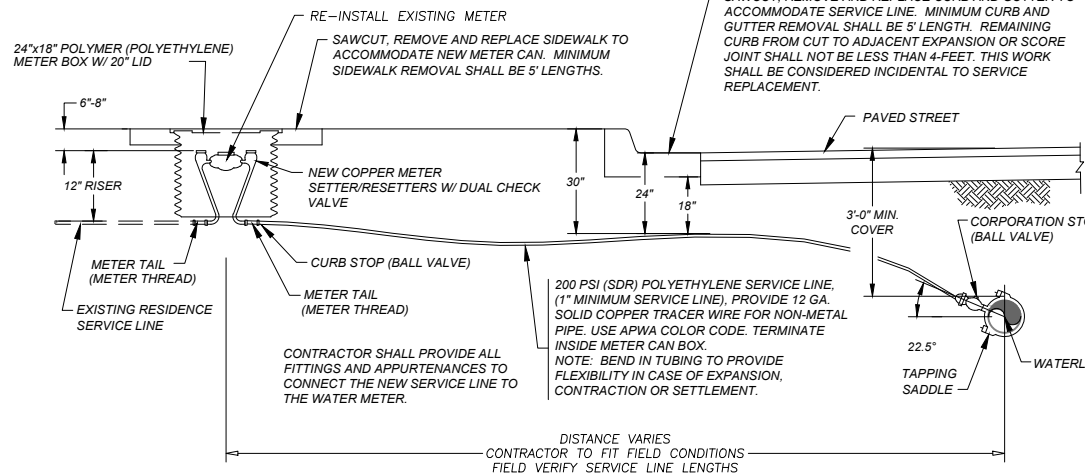

CONTRACTOR NOTE: METER CAN SHALL BE INSTALLED IN SIDEWALKS OR LANDSCAPE AREA (BETWEEN SIDEWALK AND BACK OF CURB) WITHIN RIGHT OF WAY. METER CANS SHALL NOT BE INSTALLED IN DRIVEWAYS OR VEHICULAR TRAFFIC FLOWS UNLESS LOCATION(S) AND METER CAN TYPE(S) HAVE BEEN PRE-APPROVED BY THE PUBLIC WORKS DEPARTMENT AND COMMUNITY DEVELOPMENT DEPARTMENT PRIOR TO INSTALLATION.

NOTE: THE CITY OF ALAMOGORDO RESERVES THE RIGHT TO CHANGE AND/OR MODIFY ANY ITEM(S) EITHER DETAILED OR SPECIFIED ON THIS DRAWING.

Typical City of Alamogordo Water Service Detail

No Scale

NOTE: WATER SERVICE DETAIL AND WATER SERVICE INSTALLATION MATERIAL LISTING ARE TYPICAL FOR 3/4" WATER SERVICE. ADJUSTMENTS SHALL BE MADE TO FITTINGS, CONNECTIONS, SERVICE LINE, ECT. SIZE AS REQUIRED FOR WATER SERVICES LARGER THAN 3/4". ALL FITTING, CONNECTIONS, SERVICE LINE, ETC. SHALL BE RATED FOR 150 P.S.I. (MINIMUM) WORKING PRESSURE.

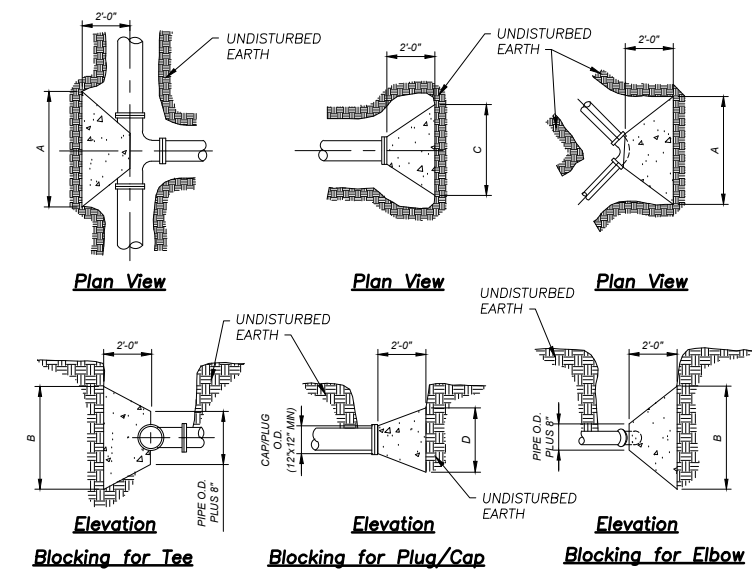

PIPE SIZE	TEE, CAP, PLUG, ELBOW ANGLE	A	B	C	D	PIPE SIZE	TEE, CAP, PLUG, ELBOW ANGLE	A	B	C	D		
4"	TEE OR CAP/PLUG	2'	1'	-	-	10"	TEE OR CAP/PLUG	3'	3'	-	-		
4"	90°	45"	-	-	2'	2'	10"	90°	-	-	3'-6"	3'-6"	
4"	22 1/2°	11 1/4"	-	-	2'	2'	10"	45°	-	-	3'	3'	
6"	TEE OR CAP/PLUG	2'	2'	-	-	10"	22 1/2°	11 1/4"	-	-	2'	2'	
6"	90°	45"	-	-	2'	2'	12"	TEE OR CAP/PLUG	3'-6"	3'-6"	-	-	
6"	22 1/2°	11 1/4"	-	-	2'	2'	12"	90°	-	-	4'	4'	
8"	TEE OR CAP/PLUG	3'	3'	-	-	12"	45°	-	-	3'-6"	3'-6"		
8"	90°	-	-	-	3'	3'	12"	22 1/2°	11 1/4"	-	-	2'	2'
8"	45°	-	-	-	2'	2'	14"	TEE OR CAP/PLUG	4'	4'	-	-	
8"	22 1/2°	11 1/4"	-	-	2'	2'	14"	90°	-	-	5'	5'	
							14"	45°	-	-	3'-6"	3'-6"	
							14"	22 1/2°	11 1/4"	-	-	3'	3'

THE DIMENSIONS ON THE TABLE ARE FOR PIPE BEING TESTED UP TO 150 P.S.I.

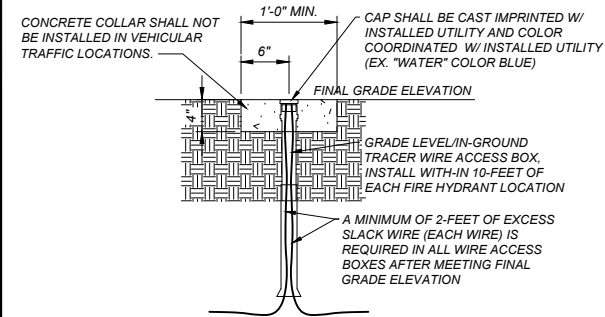

Tracer Wire Termination Detail

NO SCALE

- CONTRACTOR NOTE:**
1. TRACER WIRE ACCESS BOXES SHALL BE LOCATED AT ALL FIRE HYDRANT LOCATIONS.
 2. TRACER WIRE ACCESS BOXES SPACING SHALL NOT EXCEED 500 LINEAR FEET.
 3. COORDINATOR WITH OWNER TRACER WIRE ACCESS BOXES FINAL LOCATION(S).

- GENERAL NOTES:**
1. DIMENSION'S ±1/8" U.N.O.
 2. LID MATERIAL: HDPE
 3. BODY MATERIAL: LLDPE
 4. WALL THICKNESS: 3/8"± MINIMUM
 5. I.W.A. = INSIDE WORK AREA
 6. SNAP LOCK POCKET WILL RECEIVE AMR/AMI DEVICE ENDPOINT. SNAP LOCK SLOT IS 1.80"± .015" TO ALLOW FOR A FINGER FORCE INSTALL. POCKET HEIGHT IS 15/16" FOR A MINIMUM 1/8" AIR GAP.

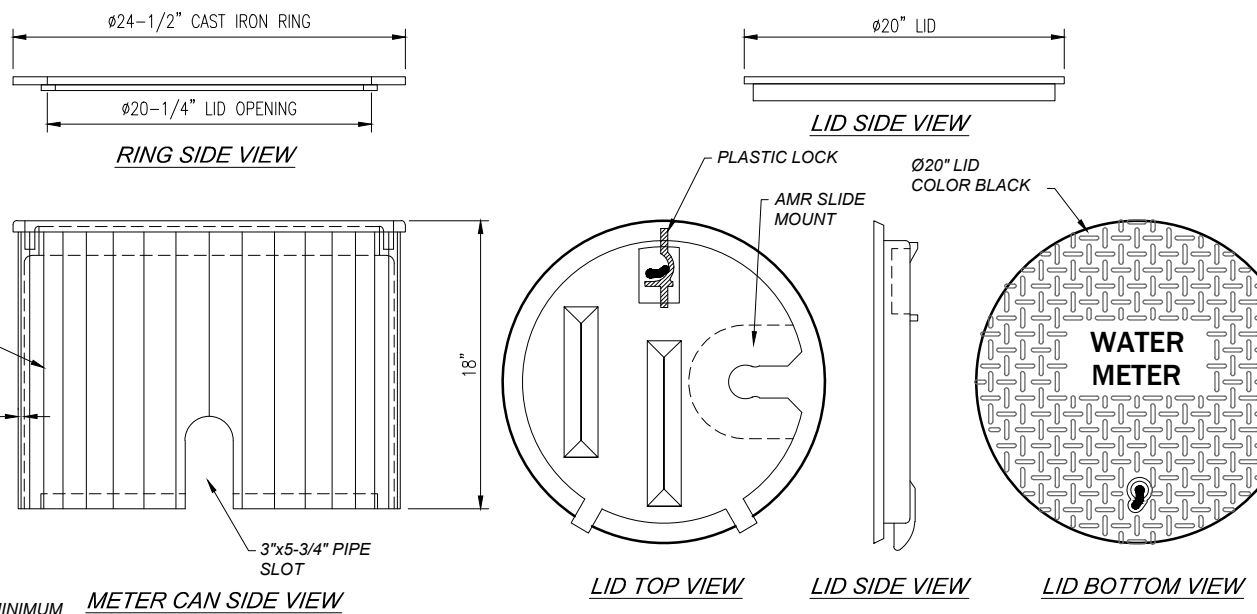

REV. No.	DATE	DESCRIPTION	APPROVED

New Mexico One Call, Inc. Call 2 days before you dig!
NMOC Dial 811 or 1-800-321-2537
 Professional Resources for Damage Prevention



Street Maintenance Program FY2018
 CITY OF ALAMOGORDO STANDARD DETAILS
 CITY OF ALAMOGORDO, NEW MEXICO, ENGINEERING DEPARTMENT

SMITH ENGINEERING
 Solutions for Today... Vision for Tomorrow
 281 N Church Street Suite 280A Las Cruces, NM 88001 Phone: 575-523-2395 www.smithengineeringpro

Public Works Bid No.: 2019-002
 Drawn By: COA Designed By: COA
 Checked By: COA Approved By: COA
 Scale: Horiz.: n/a Vert.: n/a
 HORIZ. BAR SCALE
 INCLUDE VERT SCALE ON P&P

Sheet No.: U1.0
 Sheet 37 of 49
 EN1803

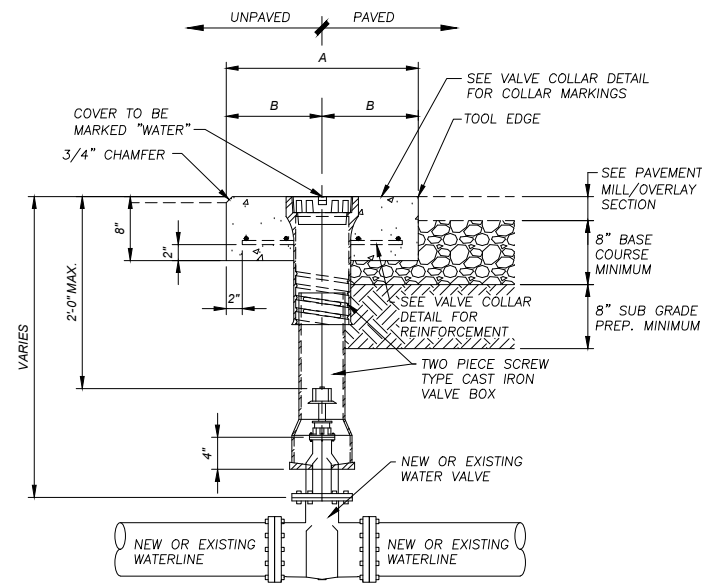

Valve Box Detail

NO SCALE

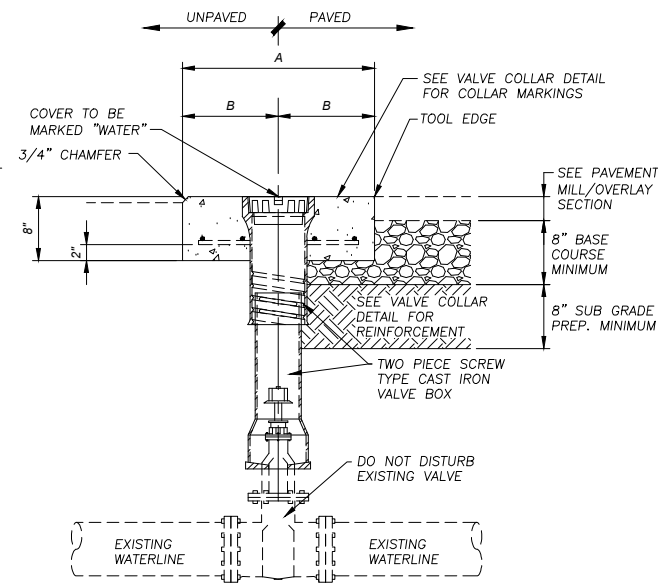

Adjust Valve Box Detail

NO SCALE

CONCRETE COLLAR TABLE		
TYPE	PAVED	UNPAVED
A	2'-0"	4'-0"
B	1'-0"	2'-0"

GENERAL NOTES:

- SEE TECHNICAL SPECIFICATION FOR BACKFILL MATERIAL SPECIFICATIONS AND COMPACTION REQUIREMENTS.
- SEE SECTION 2, STREET STANDARDS FOR PAVEMENT, BASE COURSE COURSE AND SUB-GRADE PREP. REQUIREMENTS.
- SIDES OF CONCRETE COLLAR TOP SHALL BE PARALLEL AND PERPENDICULAR TO THE NORMAL STREET TRAFFIC FLOW.

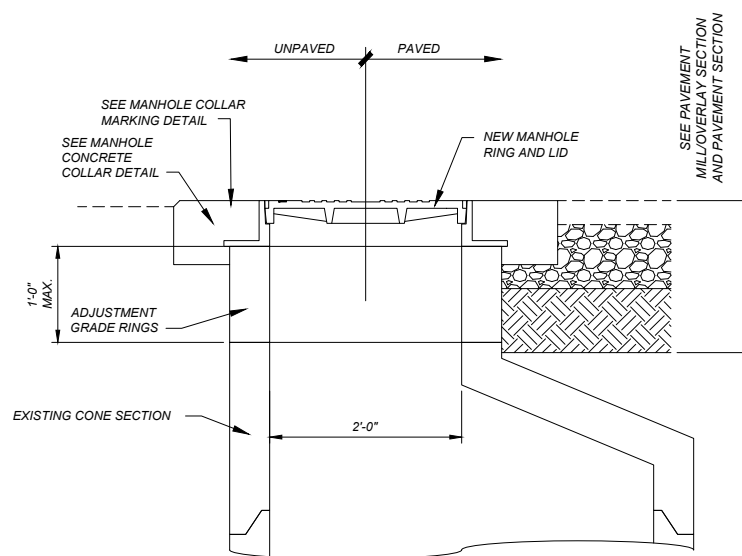

Manhole Ring and Lid Adjustment Detail

NO SCALE

GENERAL NOTES:

- SIDES OF CONCRETE COLLAR TOP SHALL BE PARALLEL AND PERPENDICULAR TO THE NORMAL STREET TRAFFIC FLOW.
- USE 3,000 P.S.I. CONCRETE FOR CONCRETE COLLARS.
- SCRIBE CONCRETE WITH LINE DIRECTIONAL ARROWS, PIPE SIZE AND PIPE TYPE.
- TEXT SIZE SHALL BE 4-INCHES TALL AND SCORED 3/8" DEEP IN A NEAT AND CONSISTENT MANNER, TYPICAL.

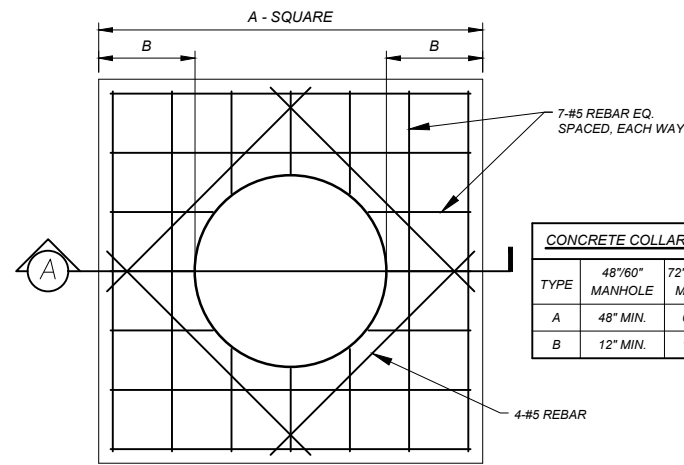

Manhole Concrete Collar Detail

NO SCALE

CONCRETE COLLAR TABLE		
TYPE	48"/60" MANHOLE	72" & LARGER MANHOLE
A	48" MIN.	60" MIN.
B	12" MIN.	12" MIN.

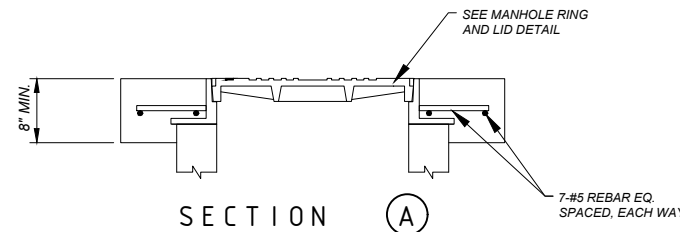

SECTION A

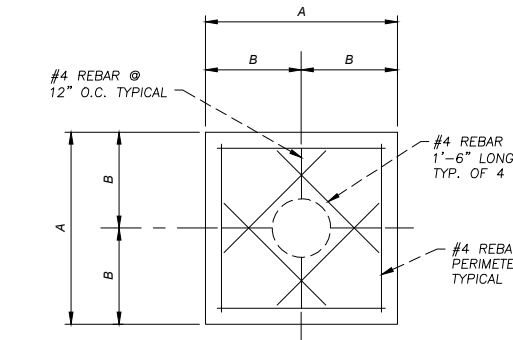

Valve Box Collar Marking Detail

NO SCALE

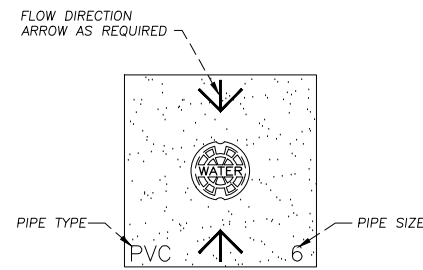

Valve Box Collar Marking Detail

NO SCALE

GENERAL NOTES:

- SIDES OF CONCRETE COLLAR TOP SHALL BE PARALLEL AND PERPENDICULAR TO THE NORMAL STREET TRAFFIC FLOW.
- SCRIBE CONCRETE WITH LINE DIRECTIONAL ARROWS, PIPE SIZE AND PIPE TYPE.
- TEXT SIZE SHALL BE 4-INCHES TALL AND SCORED 3/8" DEEP IN A NEAT AND CONSISTENT MANNER, TYPICAL.

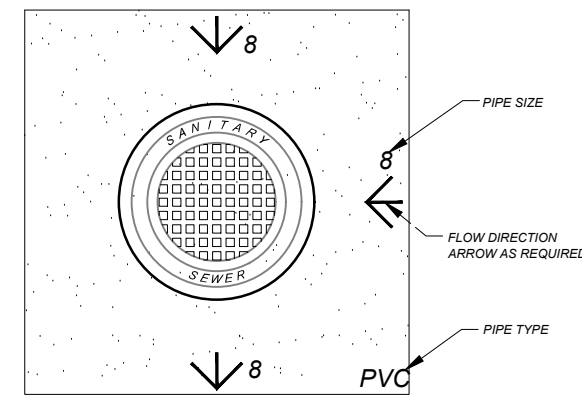

Manhole Collar Marking Detail

NO SCALE

GENERAL NOTES:

- SIDES OF CONCRETE COLLAR TOP SHALL BE PARALLEL AND PERPENDICULAR TO THE NORMAL STREET TRAFFIC FLOW.
- USE 3,000 P.S.I. CONCRETE FOR CONCRETE COLLAR.
- SCRIBE CONCRETE WITH LINE DIRECTIONAL ARROWS, PIPE SIZE AND PIPE TYPE.
- TEXT SIZE SHALL BE 4-INCHES TALL AND SCORED 3/8" DEEP IN A NEAT AND CONSISTENT MANNER, TYPICAL.

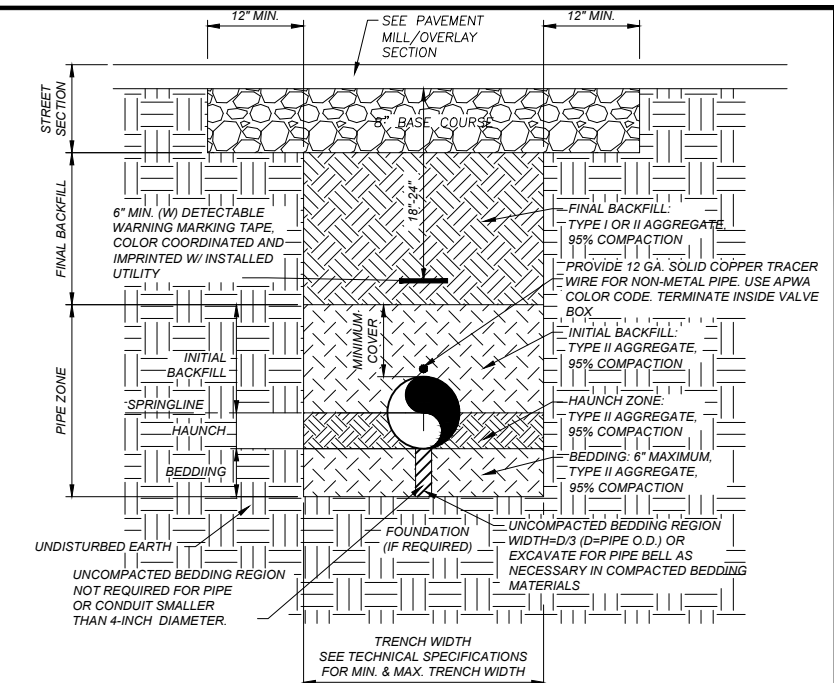

Utility Trench Cross-Section

NO SCALE

TYPE II AGGREGATE BASE BACKFILL GRADATION AND REQUIREMENTS

SIEVE SIZE	PERCENT OF DRY WEIGHT PASSING SIEVE
1-INCH	100
3/4-INCH	85 - 95
No. 4	40 - 70
No. 10	35 - 45
No. 16	25 - 35
No. 200	6 - 18
PLASTIC INDEX	12 MAXIMUM
LIQUID LIMITS	35 MAXIMUM
FRACTURED FACES	70% MINIMUM
TOTAL AVAILABLE WATER SOLUBLE SULFATES	35 MAXIMUM

GENERAL NOTES:

- SEE TECHNICAL SPECIFICATIONS FOR BACKFILL MATERIAL SPECIFICATIONS AND COMPACTION REQUIREMENTS.
- NATIVE SOIL SHALL NOT BE USED AS BACKFILL MATERIAL WITHIN THE LIMITS OF ANY ROADWAY.
- COMPACTION OF THE PIPE BEDDING MAY BE ACCOMPLISHED USING MECHANICAL TAMPING DEVICES PRIOR TO PLACEMENT OF THE PIPE OR CONDUIT. MINIMUM EXCAVATION FOR PIPE BELLS MAY BE ACCOMPLISHED AS NECESSARY TO ALLOW PROPER ALIGNMENT AND ELEVATION OF THE PIPE OR CONDUIT.
- COMPACTION IN THE HAUNCH ZONE SHALL BE COMPLETED BY HAND WITH TAMPERS OR SUITABLE POWER COMPACTORS IN MAXIMUM LIFTS OF SIX (6) INCHES. TAMPERS SHALL NOT CONTACT THE PIPE OR CONDUITS DURING THE TAMPING PROCESS.
- THE CONTRACTOR SHALL NOT EMPLOY THE USE OF IMPACT TAMPERS DIRECTLY ABOVE THE PIPE OR CONDUIT UNTIL THE FULL LOOSE LAYER BACKFILL DEPTH ABOVE THE PIPE IS OBTAINED.
- TRENCHING AND EXCAVATION OPERATIONS SHALL CONFORM TO THE CURRENT FEDERAL, STATE AND LOCAL SAFETY ORDINANCES INCLUDING ALL O.S.H.A. REGULATIONS.

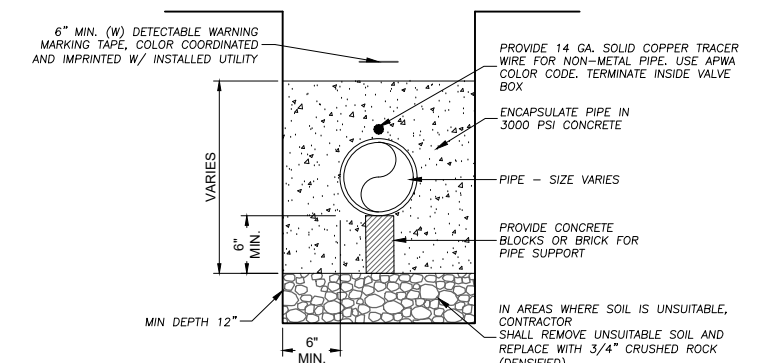

PIPE ENCASEMENT (CONCRETE)

New Mexico One Call, Inc. Call 2 days before you dig!
NMOC Dial 811 or 1-800-321-2537
 Professional Resources for Damage Prevention

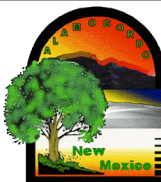

Street Maintenance Program FY2018

CITY OF ALAMOGORDO STANDARD DETAILS
 CITY OF ALAMOGORDO, NEW MEXICO, ENGINEERING DEPARTMENT

SMITH ENGINEERING
 Solutions for Today... Vision for Tomorrow
 201 N Church Street
 Las Cruces, NM 88001
 Phone: 575-523-2395
 www.smithengineering.pro

Public Works Bid No.: 2019-002
 Drawn By: COA Designed By: COA
 Checked By: COA Approved By: COA
 Scale: Horiz.: n/a Vert.: n/a
 HORIZ. BAR SCALE
 INCLUDE VERT SCALE ON P&P

Sheet No.:
U2.0
 Sheet 38 of 49
 EN1803

REV. NO.	DATE	DESCRIPTION	APPROVED

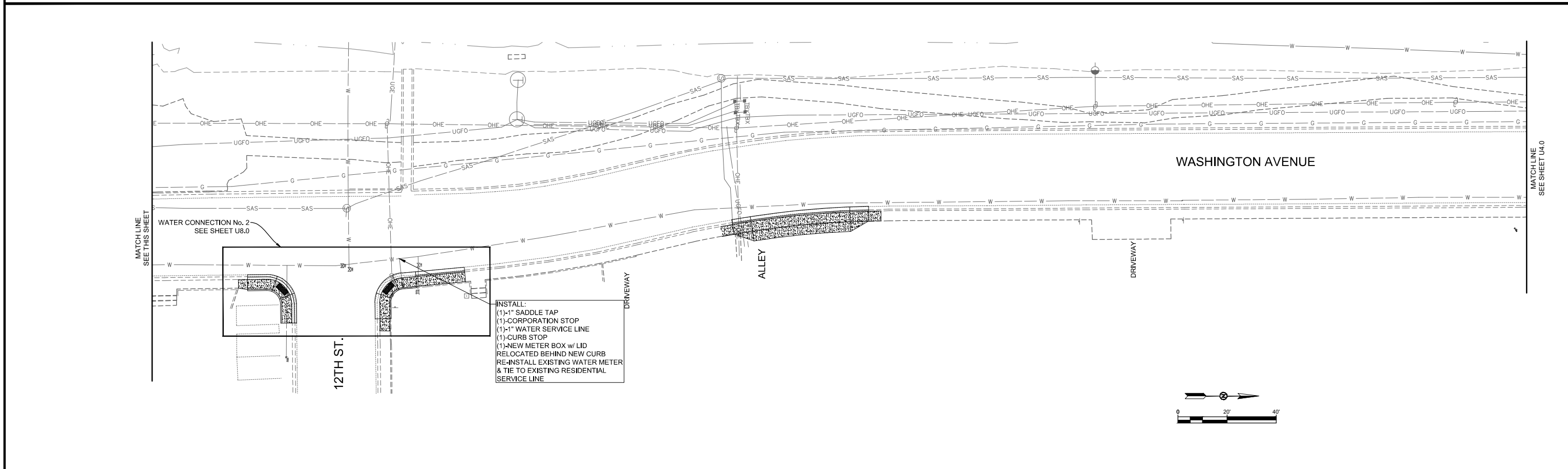
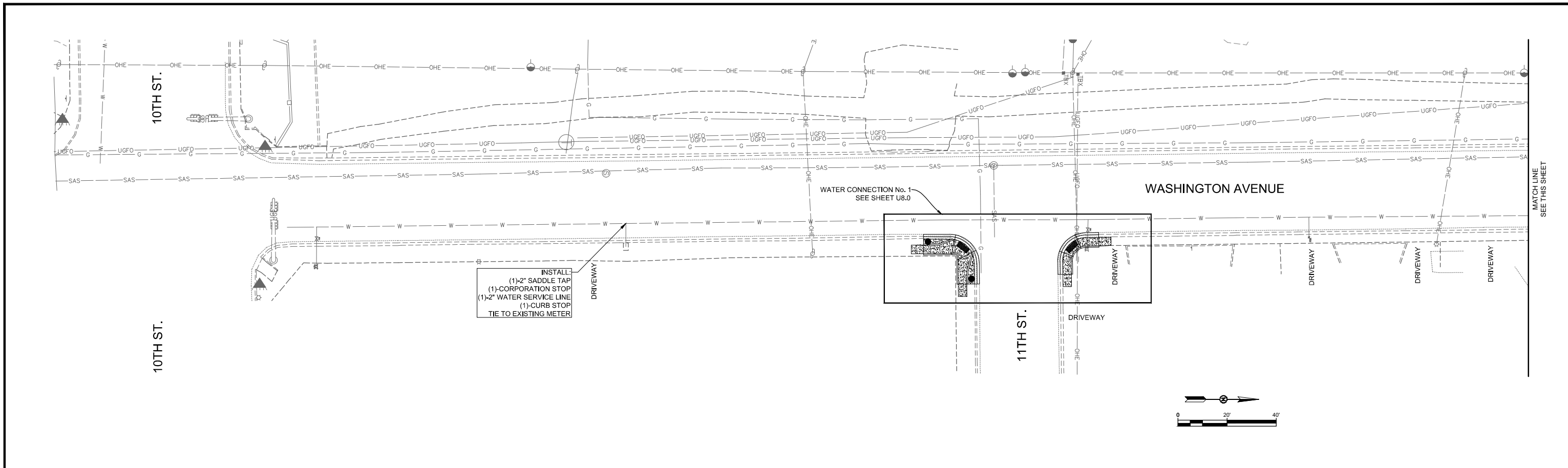

REV. No.	DATE	DESCRIPTION	APPROVED

New Mexico One Call, Inc. Call 2 days before you dig!
NMOC Dial 811 or 1-800-321-2537
 Professional Resources for Damage Prevention



Street Maintenance Program FY2018

WASHINGTON AVENUE UTILITY PLAN

CITY OF ALAMOGORDO, NEW MEXICO, ENGINEERING DEPARTMENT

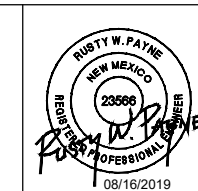

Public Works Bid No.: 2019-002
 Drawn By: MM Designed By: MM
 Checked By: RP Approved By: COA
 Scale: Horiz.: n/a Vert.: n/a
 HORIZ. BAR SCALE
 INCLUDE VERT SCALE ON P&P

Sheet No.:
U3.0
 Sheet 39 of 49
 EN1803

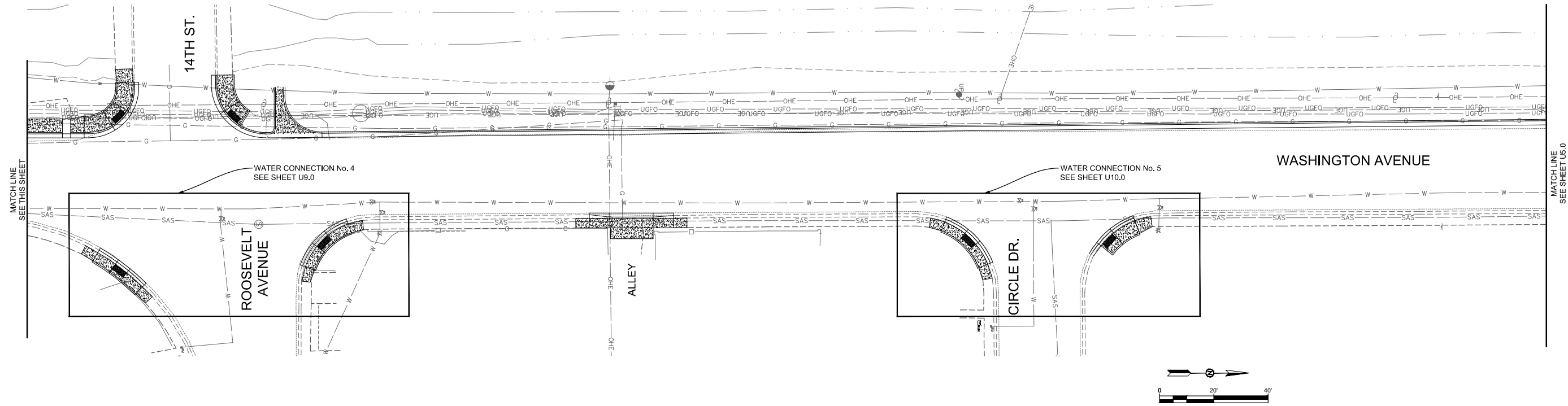
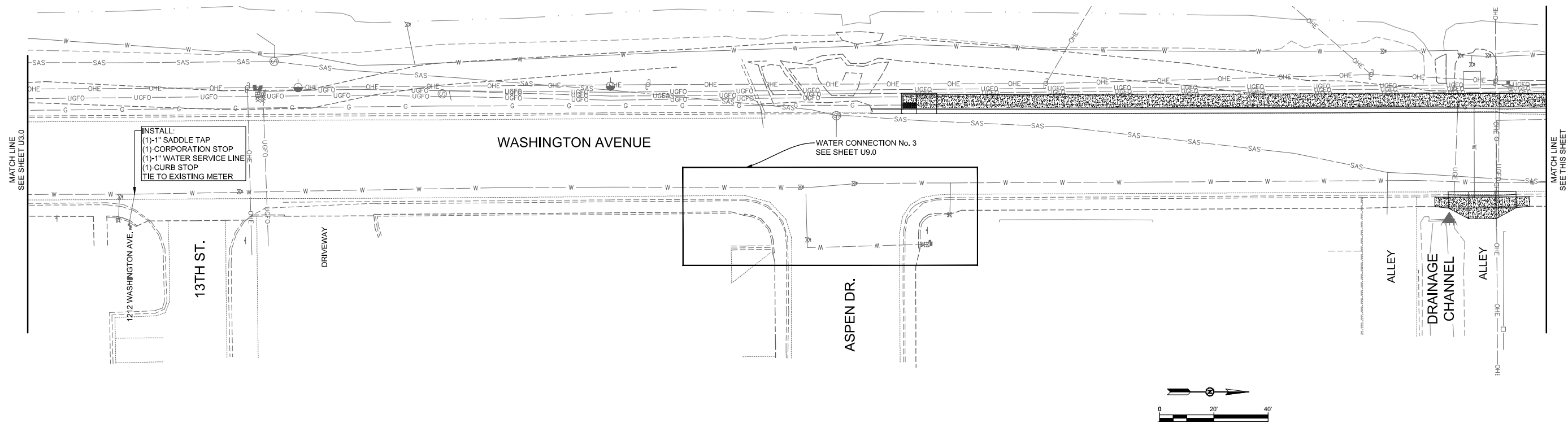

REV. No.	DATE	DESCRIPTION	APPROVED

New Mexico One Call, Inc. Call 2 days before you dig!
NMOC Dial 811 or 1-800-321-2537
 Professional Resources for Damage Prevention

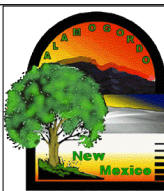

Street Maintenance Program FY2018

WASHINGTON AVENUE UTILITY PLAN

CITY OF ALAMOGORDO, NEW MEXICO, ENGINEERING DEPARTMENT

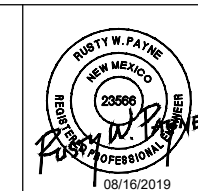

SMITH ENGINEERING
 Solutions for Today...
 Vision for Tomorrow
 201 N Church Street
 Suite 200A
 Las Cruces, NM 88001
 Phone: 575-523-2395
 www.smithengineering.pro

Public Works Bid No.: 2019-002
 Drawn By: MM Designed By: MM
 Checked By: RP Approved By: COA

Scale: Horiz.: n/a Vert.: n/a
 HORIZ. BAR SCALE
 INCLUDE VERT SCALE ON P&P

Sheet No.:
U4.0

Sheet 40 of 49

EN1803

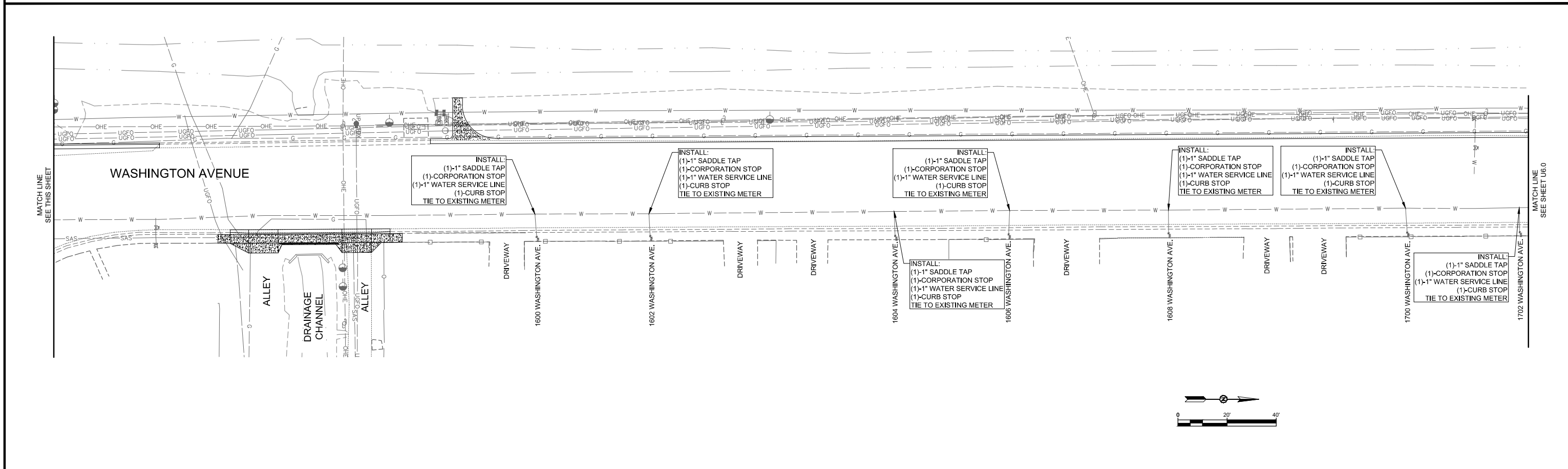
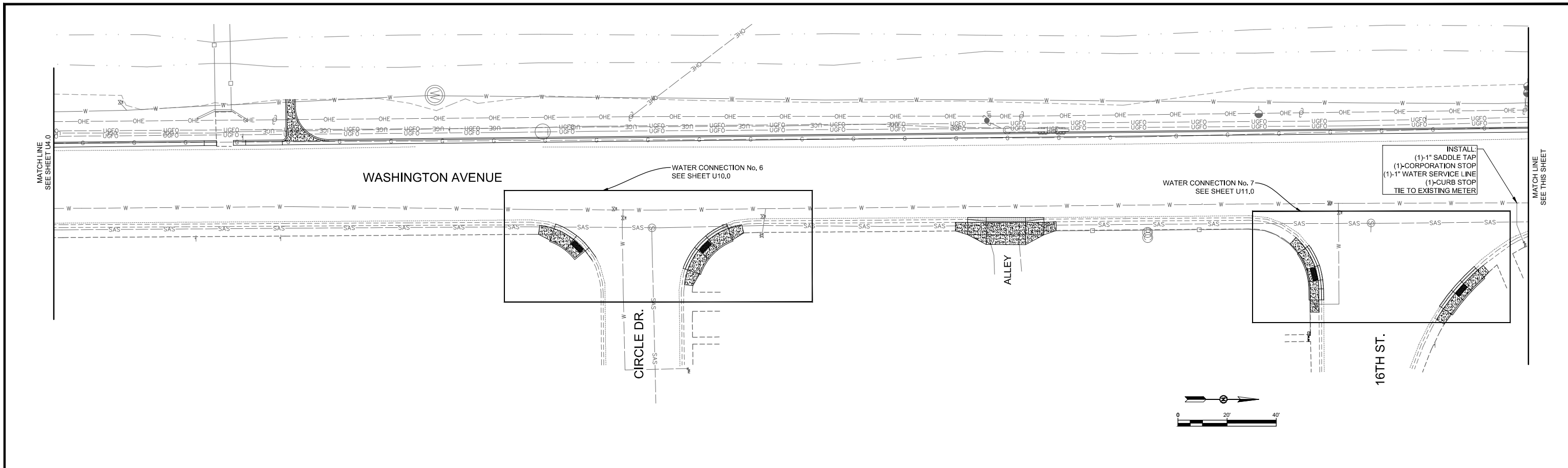

REV. No.	DATE	DESCRIPTION	APPROVED

New Mexico One Call, Inc. Call 2 days before you dig!
NMOC Dial 811 or 1-800-321-2537
 Professional Resources for Damage Prevention

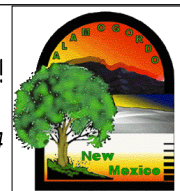

Street Maintenance Program FY2018

WASHINGTON AVENUE UTILITY PLAN

CITY OF ALAMOGORDO, NEW MEXICO, ENGINEERING DEPARTMENT

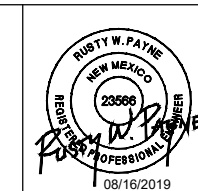

SMITH ENGINEERING
 Solutions for Today...
 Vision for Tomorrow
 201 N Church Street
 Suite 200A
 Las Cruces, NM 88001
 Phone: 575-523-2395
 www.smithengineering.pro

Public Works Bid No.: 2019-002
 Drawn By: MM Designed By: MM
 Checked By: RP Approved By: COA

Scale: Horiz.: n/a Vert.: n/a
 HORIZ. BAR SCALE
 INCLUDE VERT SCALE ON P&P

Sheet No.:
U5.0

Sheet 41 of 49
 EN1803

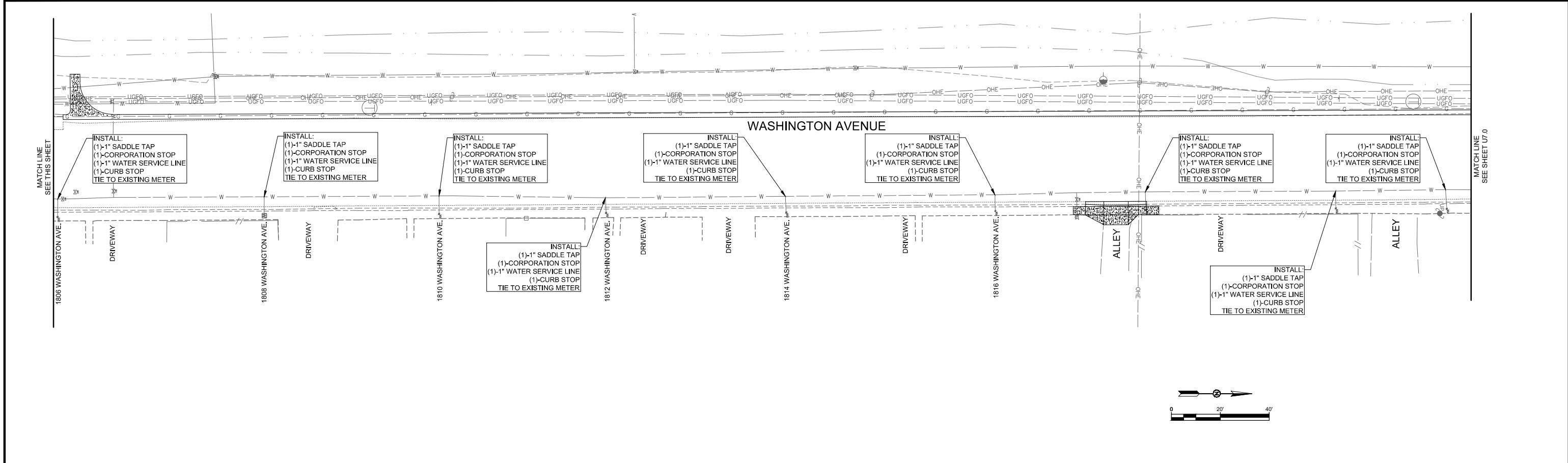
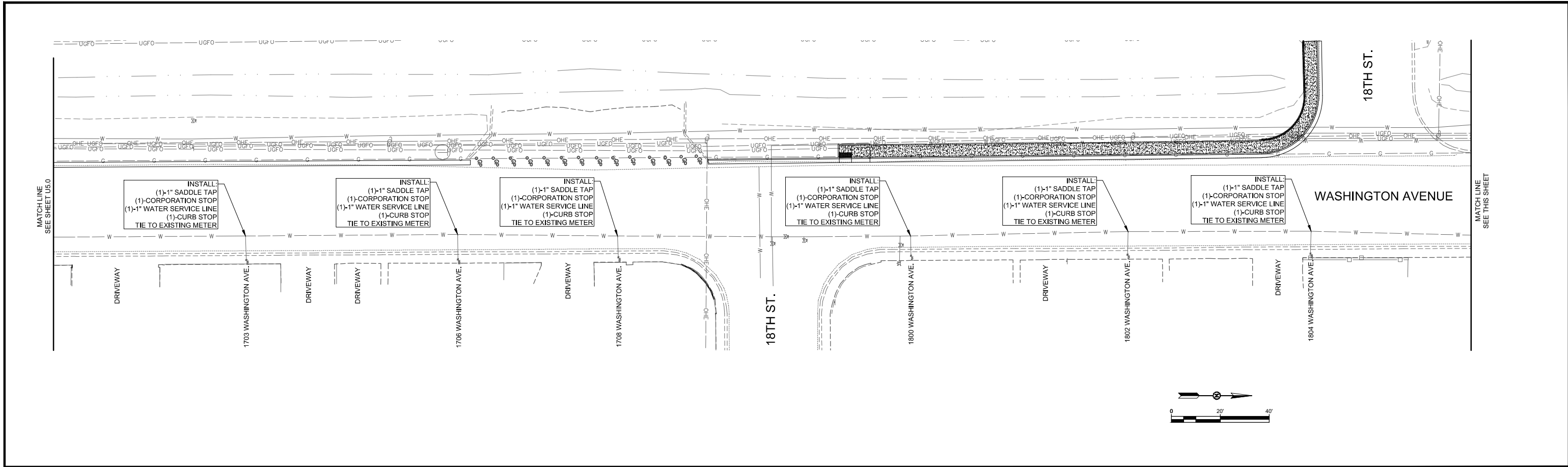

REV. No.	DATE	DESCRIPTION	APPROVED

New Mexico One Call, Inc. Call 2 days before you dig!
NMOC Dial 811 or 1-800-321-2537
 Professional Resources for Damage Prevention



Street Maintenance Program FY2018

WASHINGTON AVENUE UTILITY PLAN

CITY OF ALAMOGORDO, NEW MEXICO, ENGINEERING DEPARTMENT

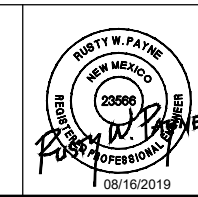

SMITH ENGINEERING
 Solutions for Today... Vision for Tomorrow
 201 N Church Street, Suite 200A, Las Cruces, NM 88001
 Phone: 575-523-2395
 www.smithengineering.pro

Public Works Bid No.: 2019-002
 Drawn By: MM Designed By: MM
 Checked By: RP Approved By: COA
 Scale: Horiz.: n/a Vert.: n/a
 HORIZ. BAR SCALE
 INCLUDE VERT SCALE ON P&P

Sheet No.: **U6.0**
 Sheet 42 of 49
 EN1803

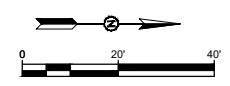
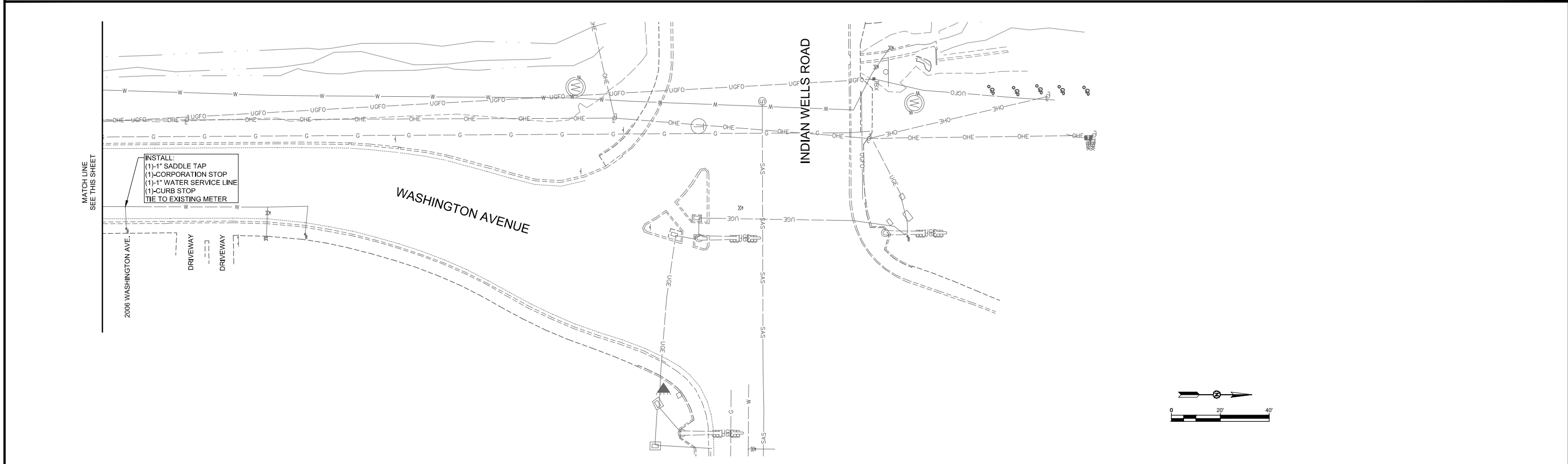
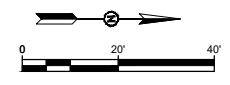
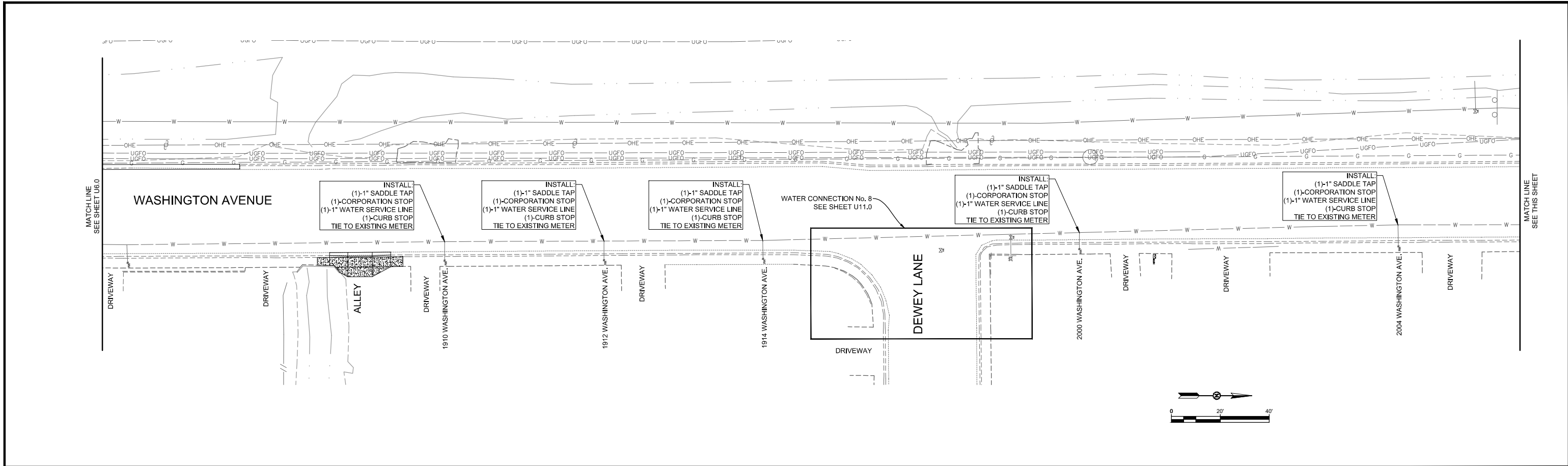

REV. No.	DATE	DESCRIPTION	APPROVED

New Mexico One Call, Inc. Call 2 days before you dig!
NMOC Dial 811 or 1-800-321-2537
 Professional Resources for Damage Prevention

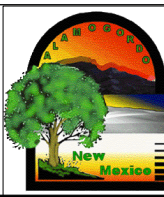

Street Maintenance Program FY2018

WASHINGTON AVENUE UTILITY PLAN

CITY OF ALAMOGORDO, NEW MEXICO, ENGINEERING DEPARTMENT

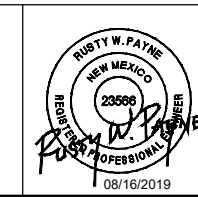

SMITH ENGINEERING
 Solutions for Today...
 Vision for Tomorrow
 201 N Church Street
 Suite 200A
 Las Cruces, NM 88001
 Phone: 575-523-2395
 www.smithengineering.pro

Public Works Bid No.: 2019-002	Sheet No.: U7.0
Drawn By: MM Designed By: MM	Sheet 43 of 49
Checked By: RP Approved By: COA	
Scale: Horiz.: n/a Vert.: n/a	EN1803
HORIZ. BAR SCALE INCLUDE VERT SCALE ON P&P	

WASHINGTON AVENUE

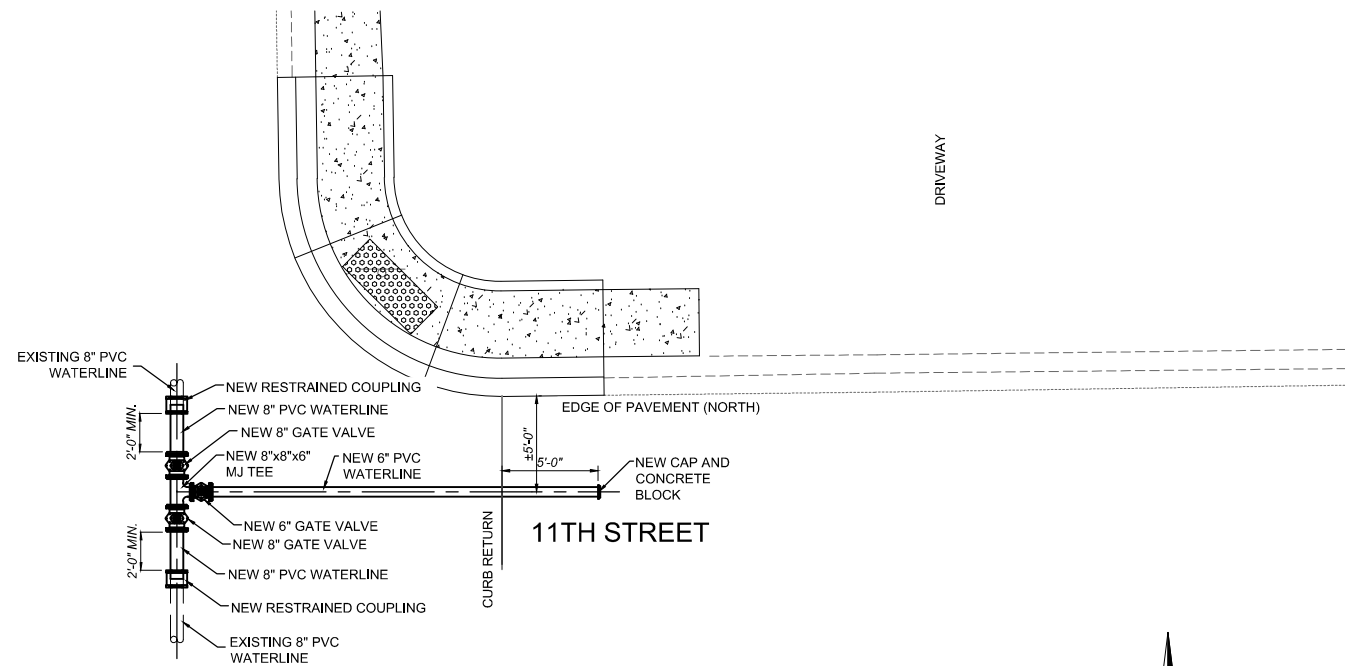

WATER CONNECTION NO. 1

GENERAL NOTES:

1. SAWCUT AND REMOVE EXISTING 6" AND/OR 8" WATERLINES, VALVE(S), FITTING(S) AND APPURTENANCES AS REQUIRED TO ACCOMMODATE THE INSTALLATION OF NEW FITTING(S), GATE VALVE(S), RESTRAINED COUPLING(S), RESTRAINED JOINT(S) AND WATERLINE PIPING AS PER DETAIL.
2. ALL JOINTS SHALL BE RESTRAINED.

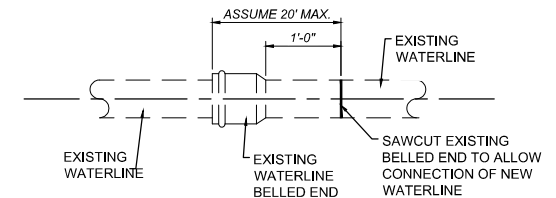
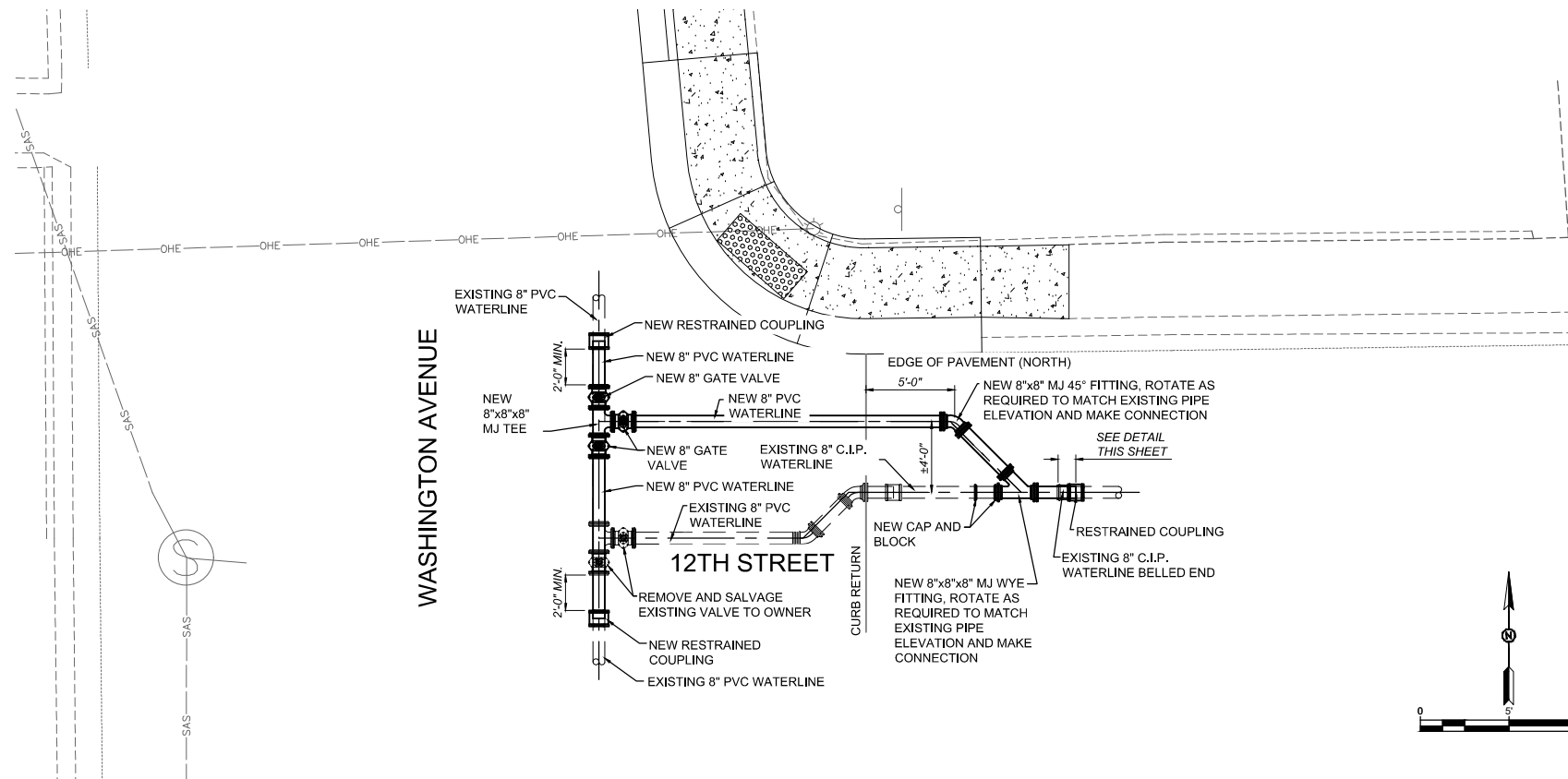
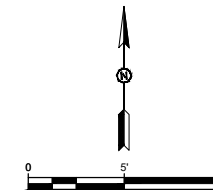

Pipeline Belled End Removal Detail

No Scale

CONTRACTOR NOTE:
FOR BIDDING PURPOSES, ASSUME 20' LINEAR FEET OF EXISTING PIPELINE SHALL BE EXCAVATED TO LOCATE PIPELINE BELLED END. ONCE BELLED END IS LOCATED CONTRACTOR SHALL KEEP EXCAVATION TO A MINIMUM AS TO NOT COMPRISE INTEGRITY OF BURIED PIPELINE.

THE INTENT OF THE BELLED END REMOVAL IS TO MAXIMIZE THE SEPARATION OF THE CONNECTION TO EXISTING WATERLINE & THE NEAREST ASSEMBLED JOINT PIPE (SPIGOT/BELL) CONNECTION.

WATER CONNECTION NO. 2

GENERAL NOTES:

1. SAWCUT AND REMOVE EXISTING 6" AND/OR 8" WATERLINES, VALVE(S), FITTING(S) AND APPURTENANCES AS REQUIRED TO ACCOMMODATE THE INSTALLATION OF NEW FITTING(S), GATE VALVE(S), RESTRAINED COUPLING(S), RESTRAINED JOINT(S) AND WATERLINE PIPING AS PER DETAIL.
2. ALL JOINTS SHALL BE RESTRAINED.

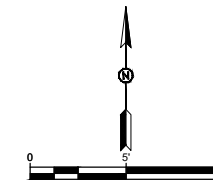

New Mexico One Call, Inc. Call 2 days before you dig!
NMOC
 Professional Resources for Damage Prevention 1-800-321-2537
 Dial 811 or



Street Maintenance Program FY2018

WASHINGTON AVENUE UTILITY PLAN
 CITY OF ALAMOGORDO, NEW MEXICO, ENGINEERING DEPARTMENT

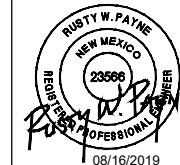

Public Works Bid No.: 2019-002
 Drawn By: MM Designed By: MM
 Checked By: RP Approved By: COA
 Scale: Horiz.: n/a Vert.: n/a
 HORIZ. BAR SCALE
 INCLUDE VERT SCALE ON P&P

Sheet No.:
U8.0
 Sheet 44 of 49
 EN1803

REV. No.	DATE	DESCRIPTION	APPROVED

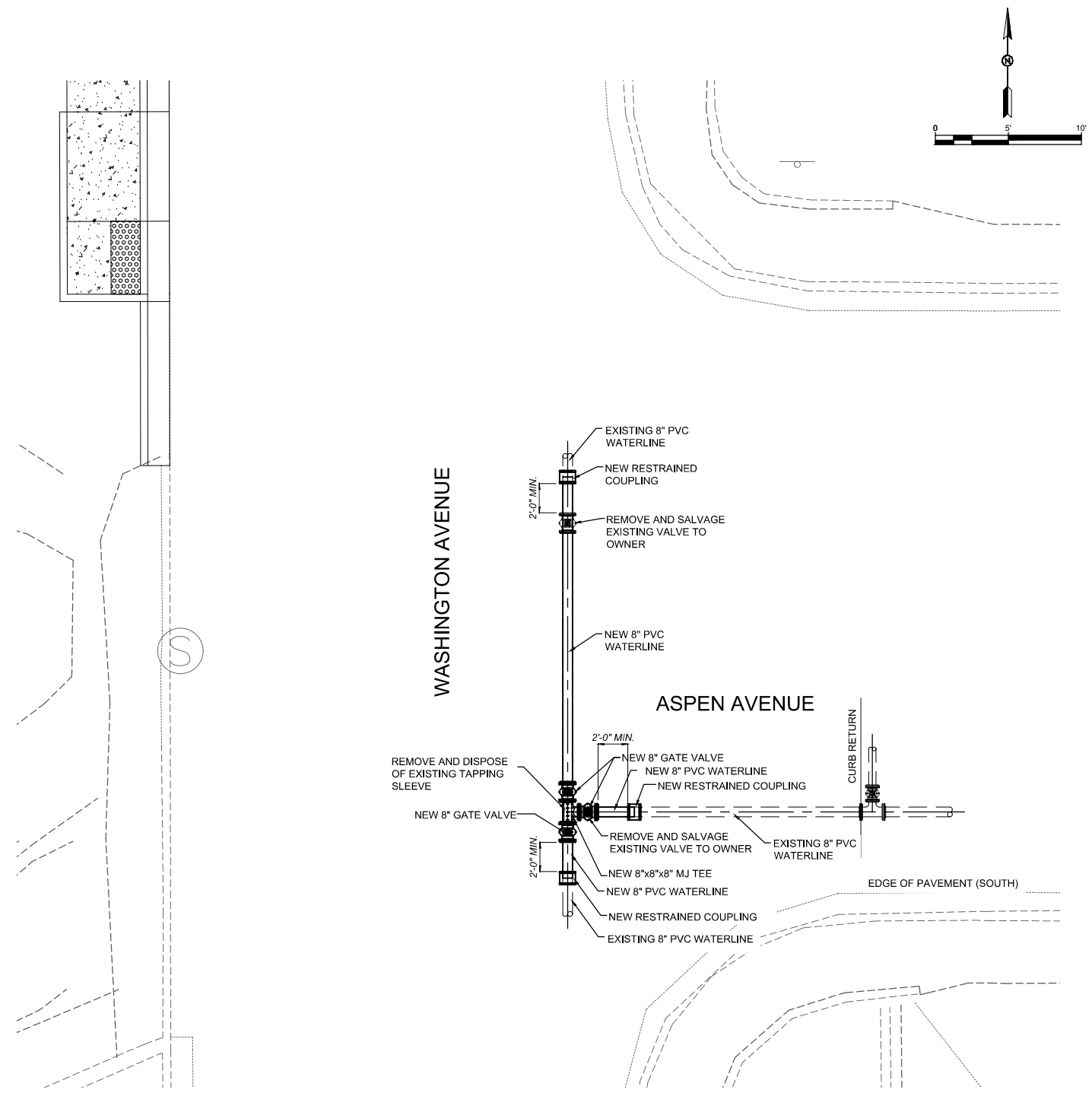

WATER CONNECTION NO. 3

- GENERAL NOTES:**
1. SAWCUT AND REMOVE EXISTING 6" AND/OR 8" WATERLINES, VALVE(S), FITTING(S) AND APPURTENANCES AS REQUIRED TO ACCOMMODATE THE INSTALLATION OF NEW FITTING(S), GATE VALVE(S), RESTRAINED COUPLING(S), RESTRAINED JOINT(S) AND WATERLINE PIPING AS PER DETAIL.
 2. ALL JOINTS SHALL BE RESTRAINED.

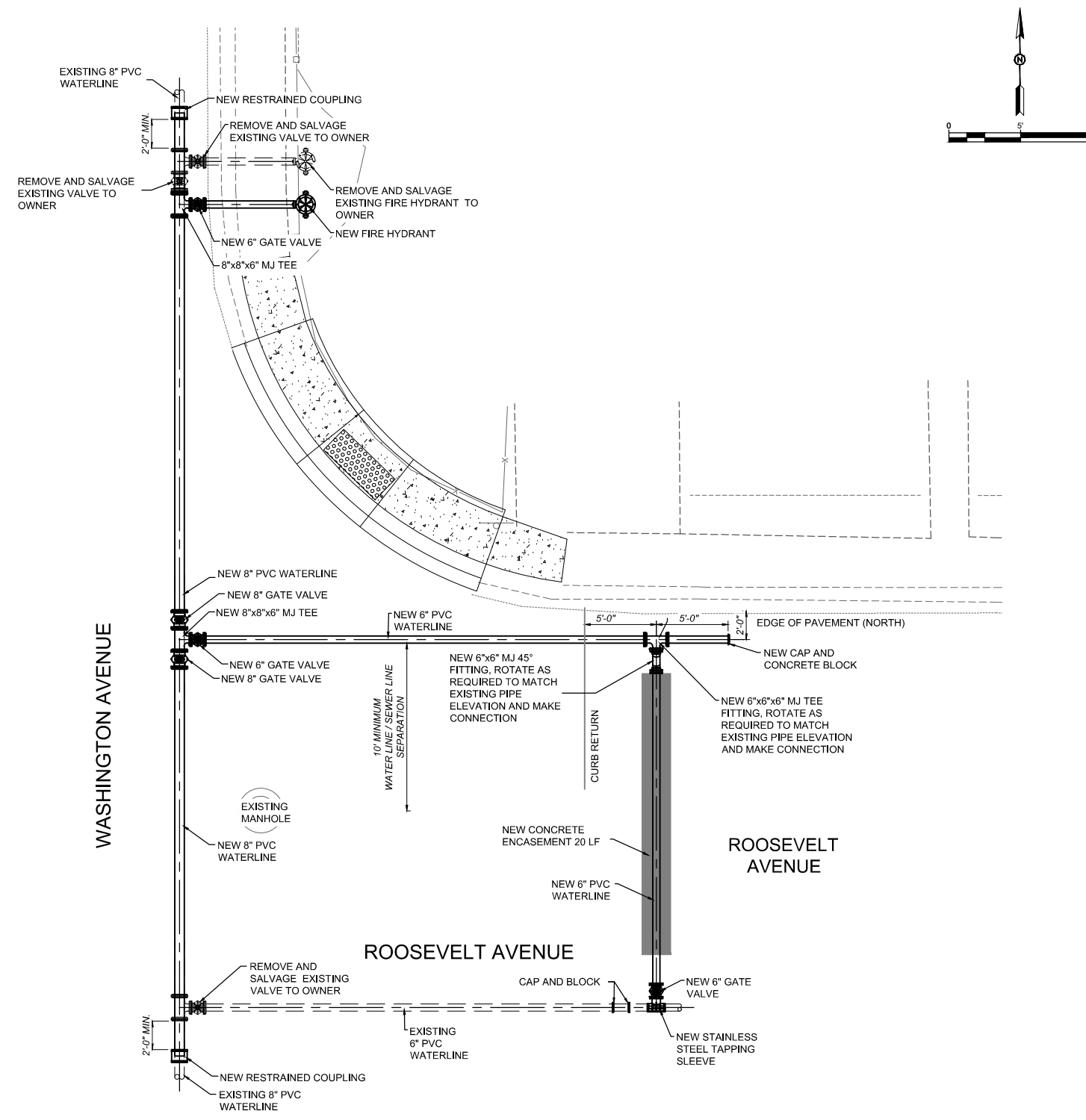

WATER CONNECTION NO. 4

- GENERAL NOTES:**
1. SAWCUT AND REMOVE EXISTING 6" AND/OR 8" WATERLINES, VALVE(S), FITTING(S) AND APPURTENANCES AS REQUIRED TO ACCOMMODATE THE INSTALLATION OF NEW FITTING(S), GATE VALVE(S), RESTRAINED COUPLING(S), RESTRAINED JOINT(S) AND WATERLINE PIPING AS PER DETAIL.
 2. ALL JOINTS SHALL BE RESTRAINED.

REV. No.	DATE	DESCRIPTION	APPROVED

New Mexico One Call, Inc. Call 2 days before you dig!
NMOC Dial 811 or 1-800-321-2537
 Professional Resources for Damage Prevention

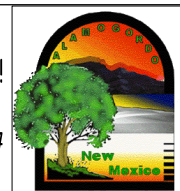

Street Maintenance Program FY2018

WASHINGTON AVENUE UTILITY PLAN
 CITY OF ALAMOGORDO, NEW MEXICO, ENGINEERING DEPARTMENT

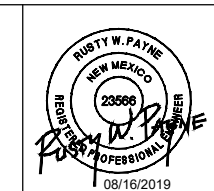

SMITH ENGINEERING
 Solutions for Today... Vision for Tomorrow
 201 N Church Street Suite 200A
 Las Cruces, NM 88001
 Phone: 575-523-2395
 www.smithengineering.pro

Public Works Bid No.: 2019-002	Sheet No.: U9.0
Drawn By: MM Designed By: MM	Sheet 45 of 49
Checked By: RP Approved By: COA	EN1803
Scale: Horiz.: n/a Vert.: n/a HORIZ. BAR SCALE INCLUDE VERT SCALE ON P&P	

WATER CONNECTION NO. 5

GENERAL NOTES:

1. SAWCUT AND REMOVE EXISTING 6" AND/OR 8" WATERLINES, VALVE(S), FITTING(S) AND APPURTENANCES AS REQUIRED TO ACCOMMODATE THE INSTALLATION OF NEW FITTING(S), GATE VALVE(S), RESTRAINED COUPLING(S), RESTRAINED JOINT(S) AND WATERLINE PIPING AS PER DETAIL.
2. ALL JOINTS SHALL BE RESTRAINED.

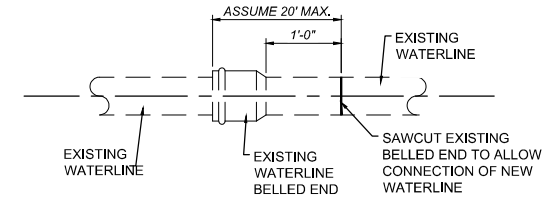
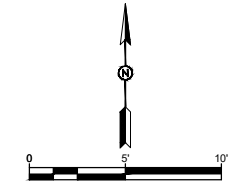
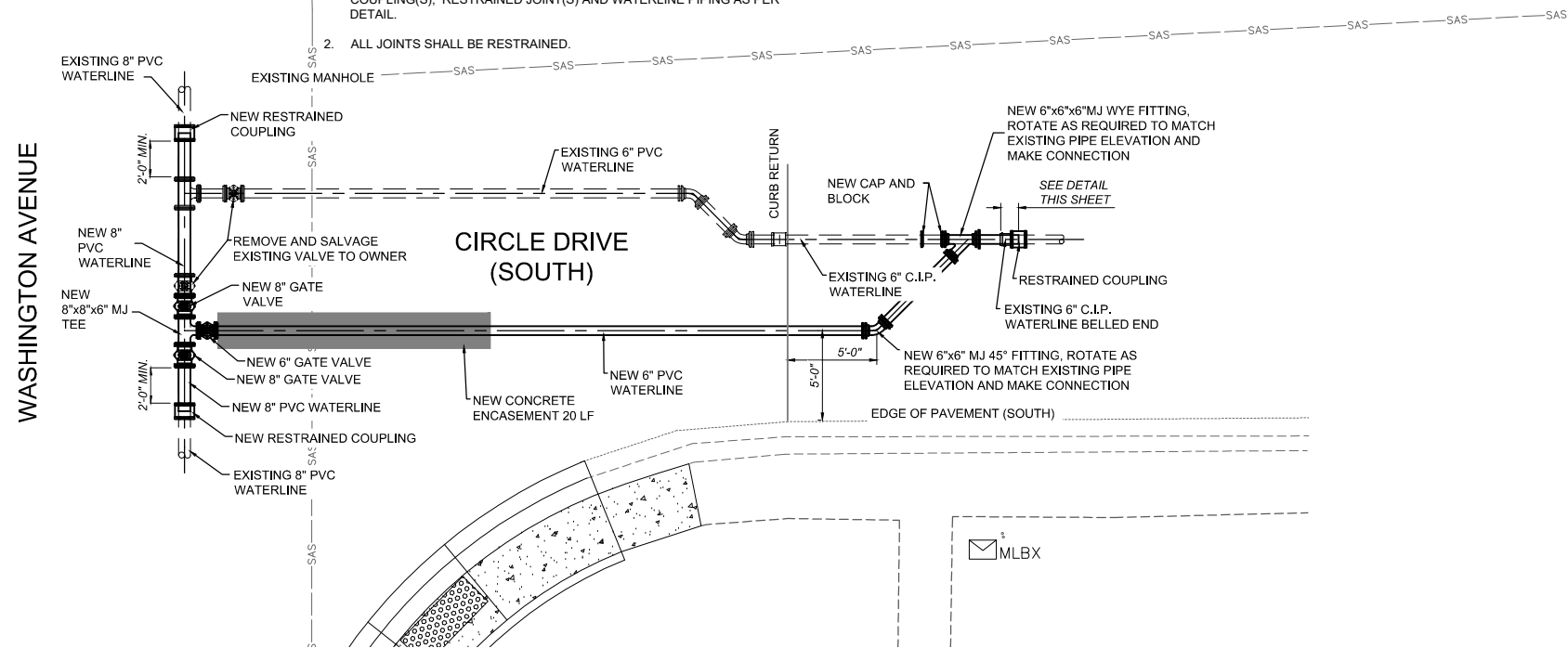

Pipeline Belled End Removal Detail

CONTRACTOR NOTE:
FOR BIDDING PURPOSES, ASSUME 20 LINEAR FEET OF EXISTING PIPELINE SHALL BE EXCAVATED TO LOCATE PIPELINE BELLED END. ONCE BELLED END IS LOCATED CONTRACTOR SHALL KEEP EXCAVATION TO A MINIMUM AS TO NOT COMPRISE INTEGRITY OF BURIED PIPELINE.

THE INTENT OF THE BELLED END REMOVAL IS TO MAXIMIZE THE SEPARATION OF THE CONNECTION TO EXISTING WATERLINE & THE NEAREST ASSEMBLED JOINT PIPE (SPIGOT/BELL) CONNECTION.

WASHINGTON AVENUE

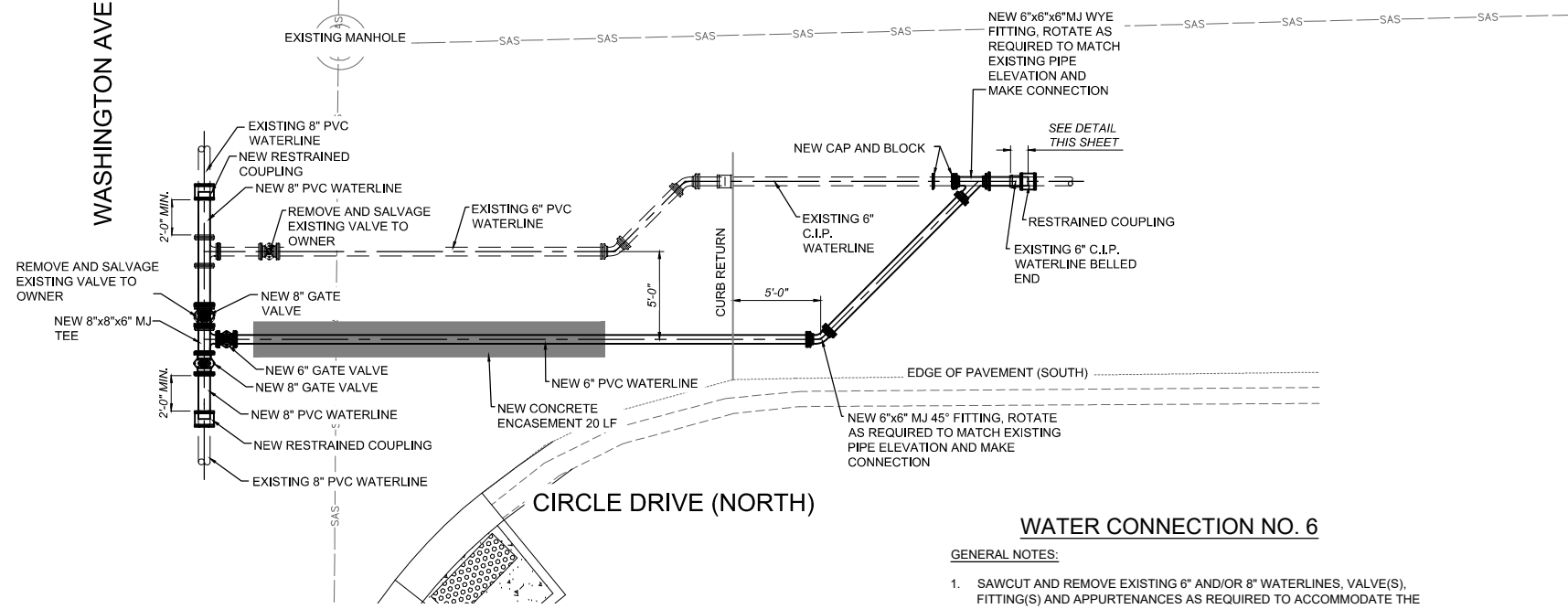

WATER CONNECTION NO. 6

GENERAL NOTES:

1. SAWCUT AND REMOVE EXISTING 6" AND/OR 8" WATERLINES, VALVE(S), FITTING(S) AND APPURTENANCES AS REQUIRED TO ACCOMMODATE THE INSTALLATION OF NEW FITTING(S), GATE VALVE(S), RESTRAINED COUPLING(S), RESTRAINED JOINT(S) AND WATERLINE PIPING AS PER DETAIL.
2. ALL JOINTS SHALL BE RESTRAINED.

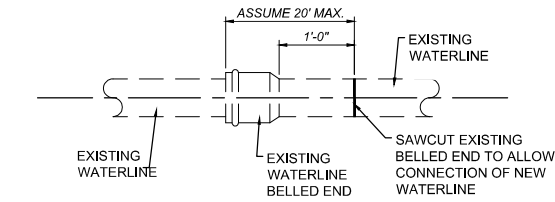
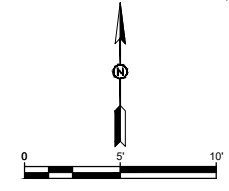

Pipeline Belled End Removal Detail

CONTRACTOR NOTE:
FOR BIDDING PURPOSES, ASSUME 20 LINEAR FEET OF EXISTING PIPELINE SHALL BE EXCAVATED TO LOCATE PIPELINE BELLED END. ONCE BELLED END IS LOCATED CONTRACTOR SHALL KEEP EXCAVATION TO A MINIMUM AS TO NOT COMPRISE INTEGRITY OF BURIED PIPELINE.

THE INTENT OF THE BELLED END REMOVAL IS TO MAXIMIZE THE SEPARATION OF THE CONNECTION TO EXISTING WATERLINE & THE NEAREST ASSEMBLED JOINT PIPE (SPIGOT/BELL) CONNECTION.

REV. No.	DATE	DESCRIPTION	APPROVED

New Mexico One Call, Inc. Call 2 days before you dig!
NMOC Dial 811 or 1-800-321-2537
 Professional Resources for Damage Prevention

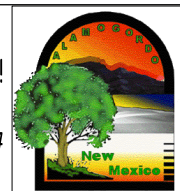

Street Maintenance Program FY2018

WASHINGTON AVENUE UTILITY PLAN

CITY OF ALAMOGORDO, NEW MEXICO, ENGINEERING DEPARTMENT

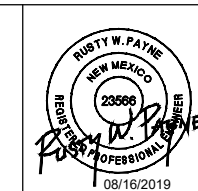

SMITH ENGINEERING

Solutions for Today... Vision for Tomorrow
 201 N Church Street Suite 200A
 Las Cruces, NM 88001
 Phone: 575-523-2395
 www.smithengineering.pro

Public Works Bid No.: 2019-002
 Drawn By: MM Designed By: MM
 Checked By: RP Approved By: COA

Scale: Horiz.: n/a Vert.: n/a
 HORIZ. BAR SCALE
 INCLUDE VERT SCALE ON P&P

Sheet No.: U10.0
 Sheet 46 of 49
 EN1803

WASHINGTON AVENUE

WATER CONNECTION NO. 7

GENERAL NOTES:

1. SAWCUT AND REMOVE EXISTING 6" AND/OR 8" WATERLINES, VALVE(S), FITTING(S) AND APPURTENANCES AS REQUIRED TO ACCOMMODATE THE INSTALLATION OF NEW FITTING(S), GATE VALVE(S), RESTRAINED COUPLING(S), RESTRAINED JOINT(S) AND WATERLINE PIPING AS PER DETAIL.
2. ALL JOINTS SHALL BE RESTRAINED.

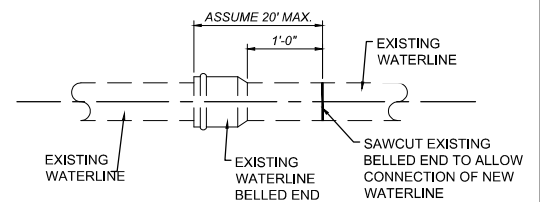
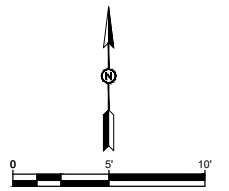
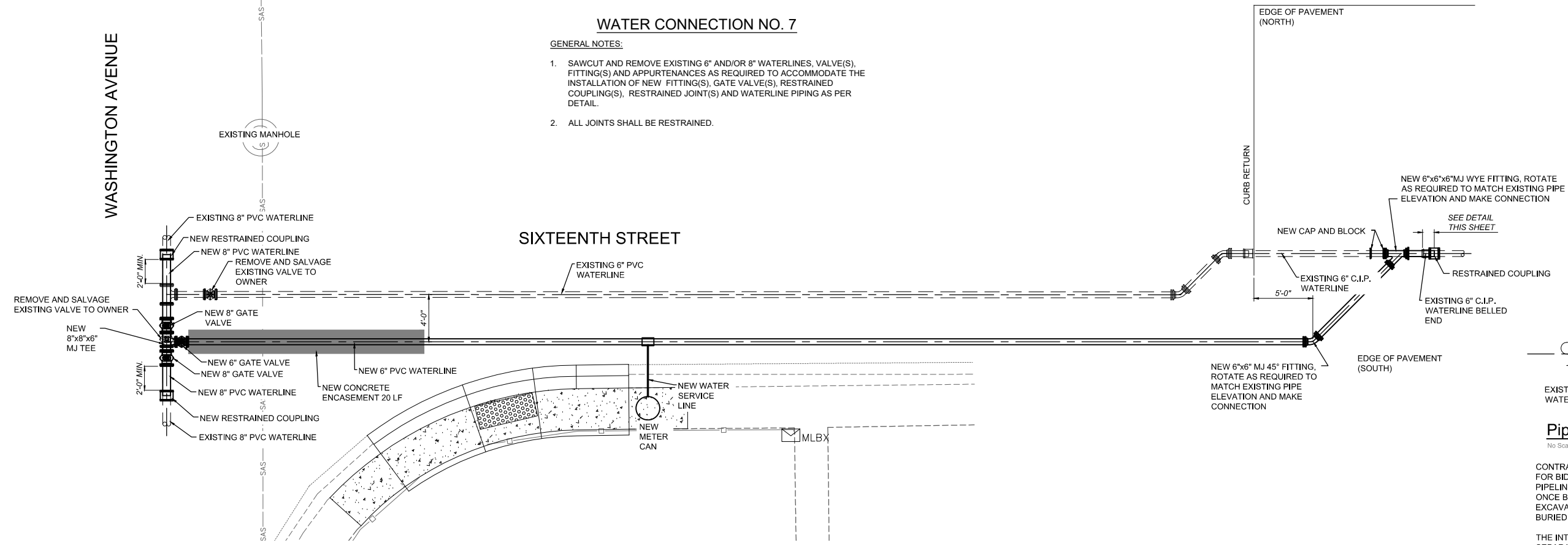

Pipeline Belled End Removal Detail
No Scale

CONTRACTOR NOTE:
FOR BIDDING PURPOSES, ASSUME 20 LINEAR FEET OF EXISTING PIPELINE SHALL BE EXCAVATED TO LOCATE PIPELINE BELLED END. ONCE BELLED END IS LOCATED CONTRACTOR SHALL KEEP EXCAVATION TO A MINIMUM AS TO NOT COMPRISE INTEGRITY OF BURIED PIPELINE.

THE INTENT OF THE BELLED END REMOVAL IS TO MAXIMIZE THE SEPARATION OF THE CONNECTION TO EXISTING WATERLINE & THE NEAREST ASSEMBLED JOINT PIPE (SPIGOT/BELL) CONNECTION.

WASHINGTON AVENUE

DEWEY LANE

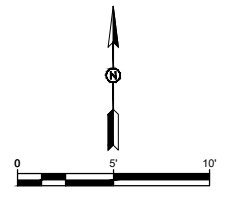
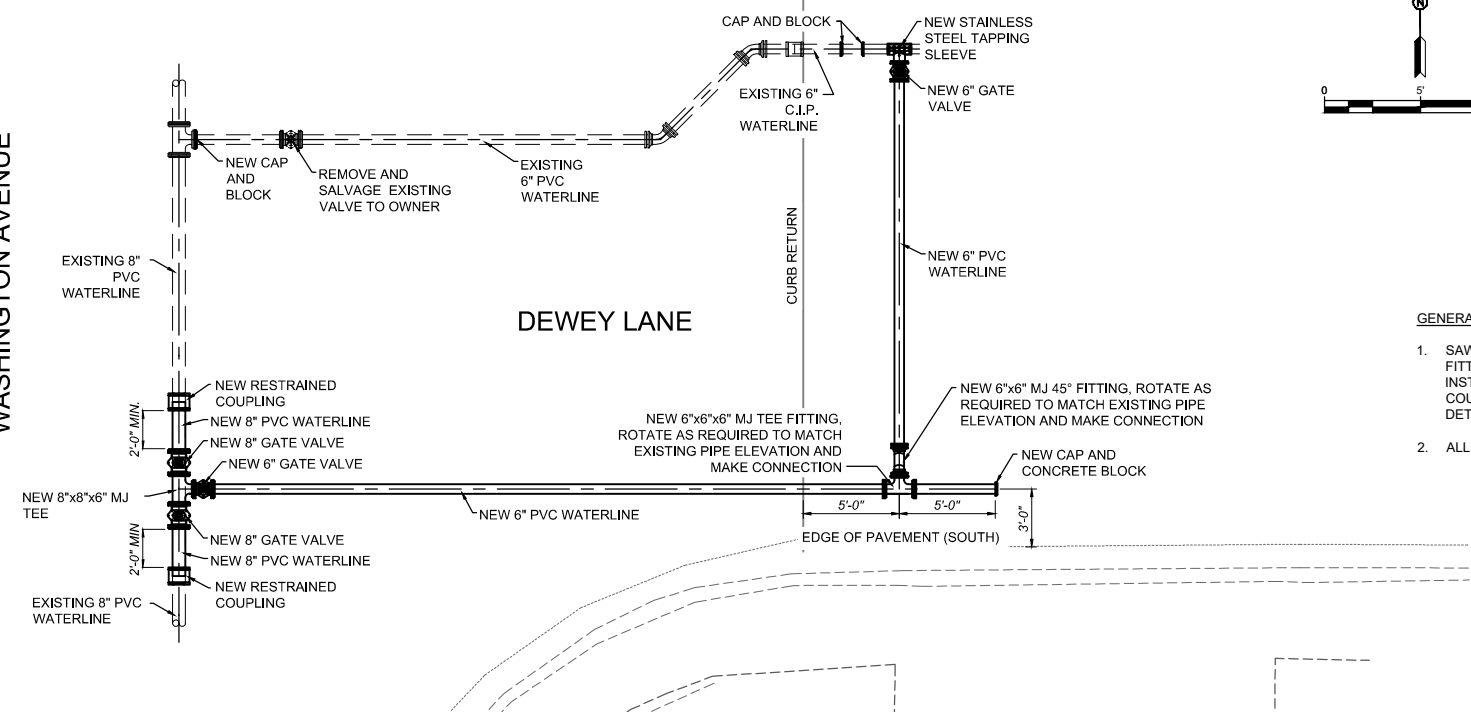

WATER CONNECTION NO. 8

GENERAL NOTES:

1. SAWCUT AND REMOVE EXISTING 6" AND/OR 8" WATERLINES, VALVE(S), FITTING(S) AND APPURTENANCES AS REQUIRED TO ACCOMMODATE THE INSTALLATION OF NEW FITTING(S), GATE VALVE(S), RESTRAINED COUPLING(S), RESTRAINED JOINT(S) AND WATERLINE PIPING AS PER DETAIL.
2. ALL JOINTS SHALL BE RESTRAINED.

REV. No.	DATE	DESCRIPTION	APPROVED

New Mexico One Call, Inc. Call 2 days before you dig!
NMOC
 Professional Resources for Damage Prevention 1-800-321-2537
 Dial 811 or

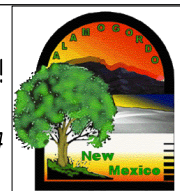

Street Maintenance Program FY2018

WASHINGTON AVENUE UTILITY PLAN
 CITY OF ALAMOGORDO, NEW MEXICO, ENGINEERING DEPARTMENT

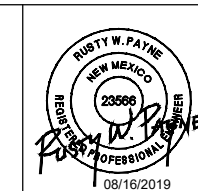

SMITH ENGINEERING
 Solutions for Today... Vision for Tomorrow
 201 N Church Street
 Suite 200A
 Las Cruces, NM 88001
 Phone: 575-523-2395
 www.smithengineering.pro

Public Works Bid No.: 2019-002
 Drawn By: MM Designed By: MM
 Checked By: RP Approved By: COA

Scale: Horiz.: n/a Vert.: n/a
 HORIZ. BAR SCALE
 INCLUDE VERT SCALE ON P&P

Sheet No.:
U11.0

Sheet 47 of 49
 EN1803

GENERAL NOTES:

- DESIGN AND CONSTRUCTION SHALL CONFORM TO THE NEW MEXICO STATE DEPARTMENT OF TRANSPORTATION'S STANDARD SPECIFICATIONS FOR HIGHWAY AND BRIDGE CONSTRUCTION, CURRENT EDITION AND SUPPLEMENTAL SPECIFICATIONS AND SPECIAL PROVISIONS.
- STEEL STRUCTURES SHALL CONFORM TO SECTION 541 - STEEL STRUCTURES OF THE STANDARD SPECIFICATIONS AND AASHTO M 270, GRADE 50. TUBING SHALL CONFORM TO ASTM A 500, GRADE B.
- BOLTS, NUTS, AND WASHERS SHALL BE GALVANIZED TO MEET THE REQUIREMENTS OF AASHTO M 111 OR AASHTO M 298.
- WELDING SHALL MEET THE REQUIREMENTS OF ANSI/AWS D 1.1 STRUCTURAL WELDING CODE, AND SECTION 541 OF THE STANDARD SPECIFICATIONS. ALL WELDS SHALL BE GROUND SO AS TO REMOVE ALL BURS OR PROTUBERANCES WHICH COULD TRAP FOREIGN MATERIALS OR CAUSE HARM TO A PEDESTRIAN.
- THE FABRICATOR SHALL FURNISH TO THE BRIDGE ENGINEER SIX COPIES OF MILL TEST REPORTS OF ALL STRUCTURAL STEEL ITEMS, WELDING ELECTRODES, AND FLUX COMBINATIONS IN CONFORMANCE WITH SUBSECTION 541.3.2.1 OF THE STANDARD SPECIFICATIONS.
- UNLESS OTHERWISE NOTED IN THE CONTRACT, THE PROJECT MANAGER SHALL SELECT EITHER TYPE A OR TYPE B RAILING ENDS, AND SCHEME 1 OR SCHEME 2 FOR FOUNDATIONS.
- 1" STANDARD PIPE HANDRAIL SHALL BE USED FOR GRADES EQUAL TO OR EXCEEDING 5%. 1" STANDARD PIPE HANDRAIL SHALL BE USED FOR GRADES LESS THAN 5%, WHEN SPECIFIED IN THE PLANS.
- POSTS SHALL BE VERTICAL. ALL RAILS SHALL BE PARALLEL TO EACH OTHER AND TO GRADE.
- BREAKS IN VERTICAL ALIGNMENTS SHALL BE AT THE CENTER LINES OF THE VERTICAL POSTS.
- CONCRETE SHALL BE CLASS "AA" AND SHALL BE INCLUDED IN THE BID PRICE FOR SIDEWALKS. IN INSTANCES WHERE THERE ARE NO SIDEWALKS, THE BID PRICE OF THE PEDESTRIAN RAILING INCLUDES THE COST OF CONCRETE TO SUPPORT THE POSTS.
- RAIL POSTS SHALL BE CAST-IN-PLACE, OR SET IN OVERSIZED HOLES (3" IN DIAMETER) AND GROUTED AS OUTLINED IN SECTION 522 OR 523 OF THE STANDARDS SPECIFICATIONS.
- AFTER GROUTING, THE CONTRACTOR SHALL SEAL THE JOINTS BETWEEN THE RAIL POSTS AND THE CONCRETE WITH SILICONE SEALANT APPROVED BY THE PROJECT MANAGER.
- PAINTING AND/OR POWDER COATING OF STRUCTURAL STEEL SHALL CONFORM TO SECTION 545 OR SPECIAL PROVISIONS OF THE STANDARD SPECIFICATIONS. COLOR SHALL BE VERIFIED BY PROJECT MANAGER. REINFORCING BARS SHALL BE EPOXY COATED CONFORMING TO SECTION 540.

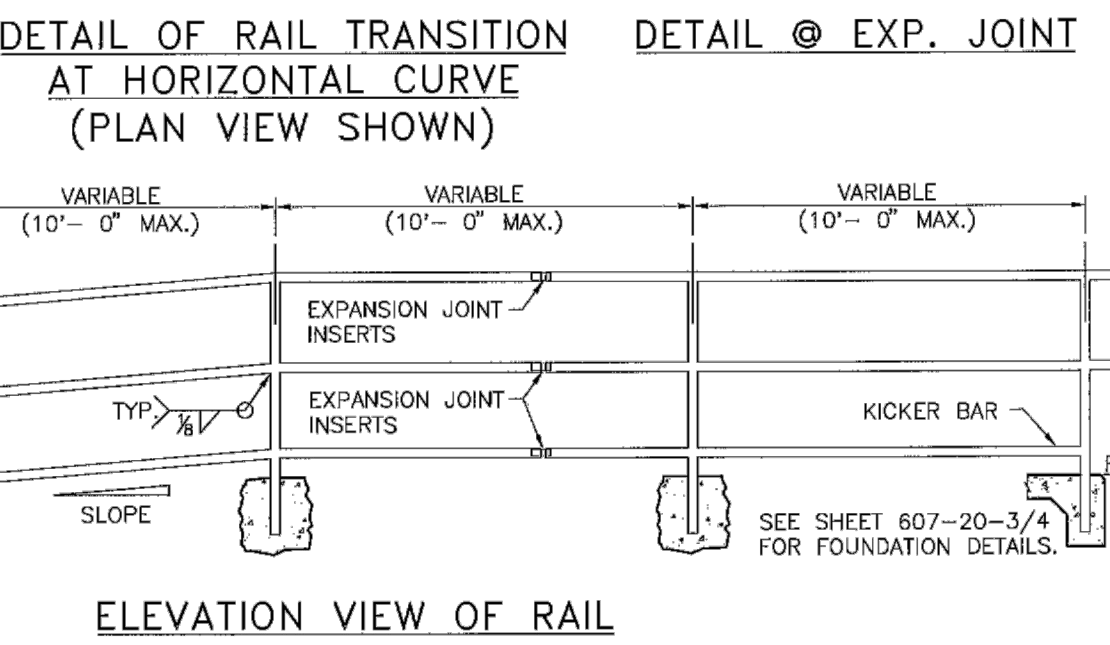
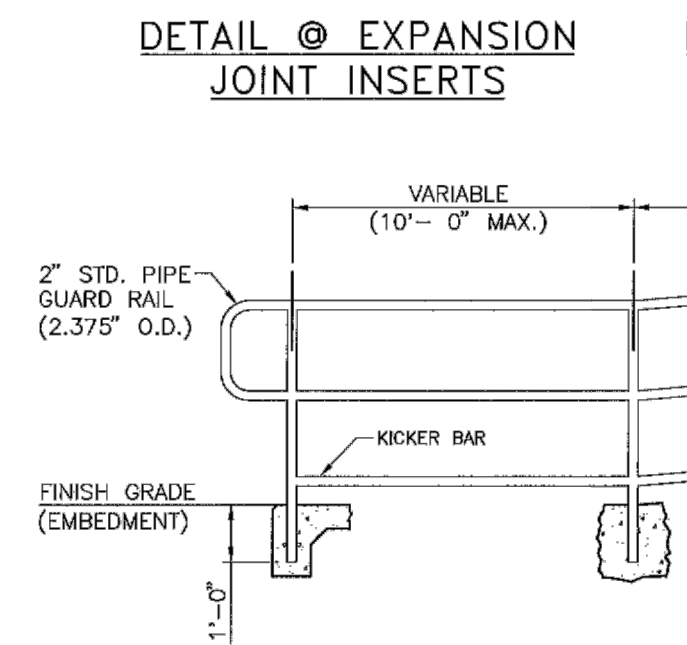
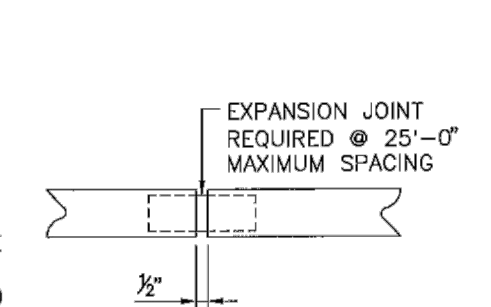
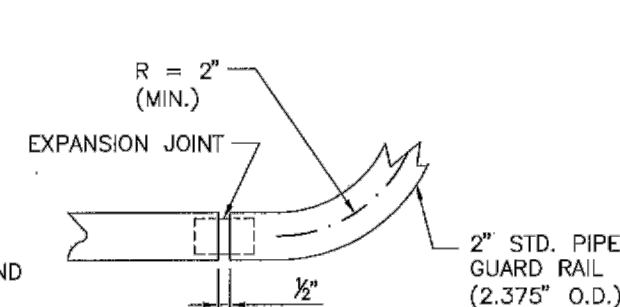
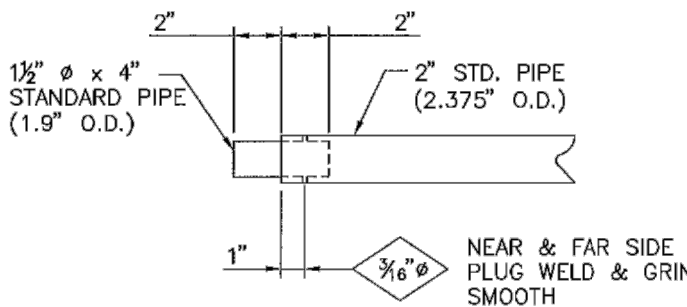
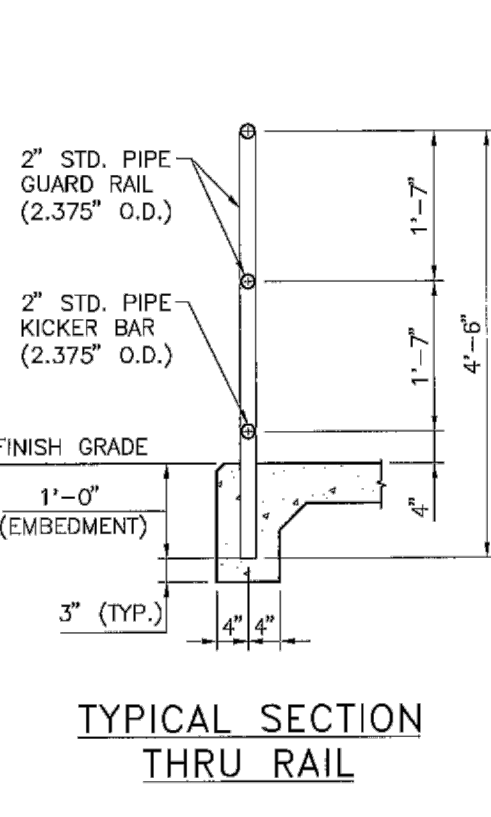
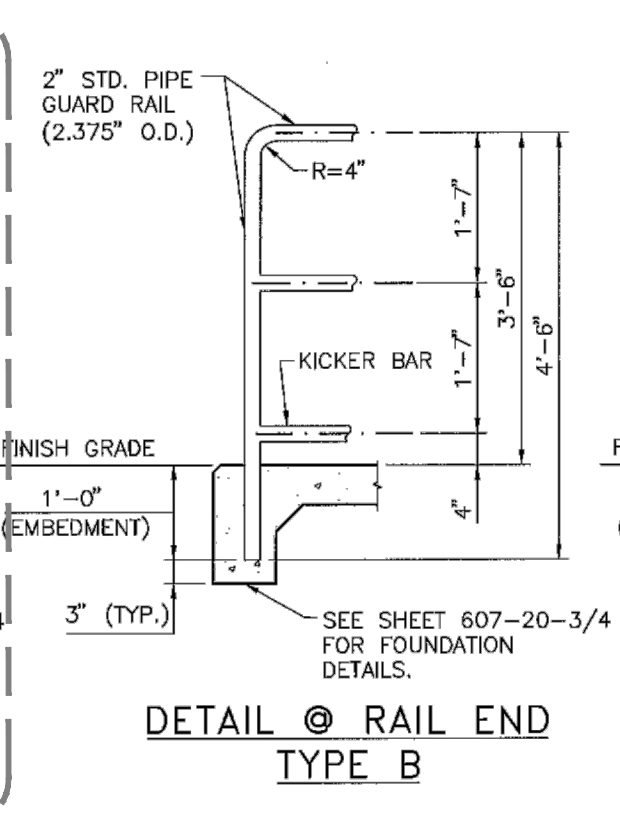
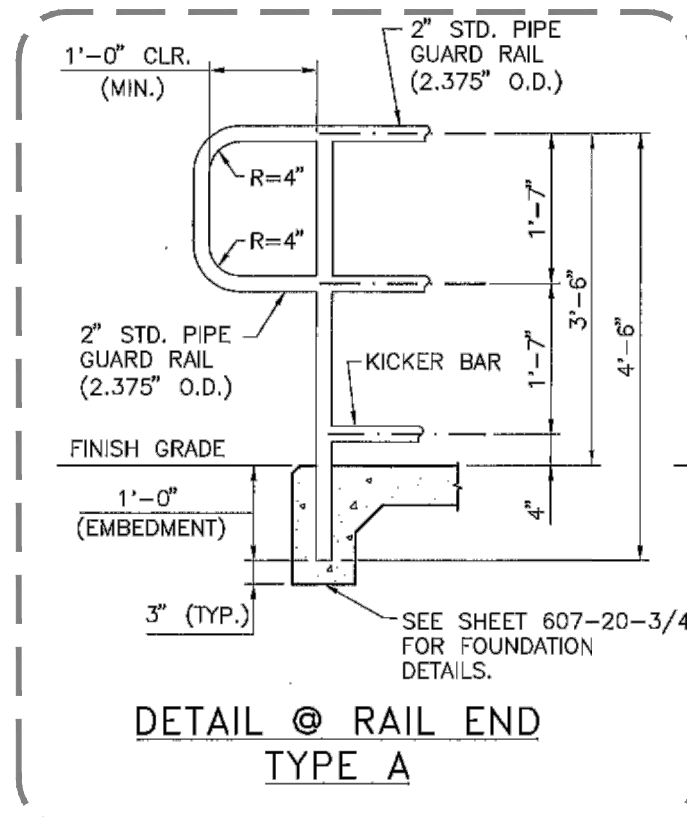

NOTE: POSTS TO REMAIN VERTICAL, RAIL PARALLEL TO GRADE.



DATE	BY	DESCRIPTION
REVISIONS (OR CHANGE NOTICES)		
NEW MEXICO		
DEPARTMENT OF TRANSPORTATION		
STANDARD DRAWING		
PEDESTRIAN RAILING		
WITHOUT HANDRAIL		
DESIGNED BY: TM	DRAWN BY: SKL	CHECKED BY: YML/TM
607-20-1/4		1 of 4

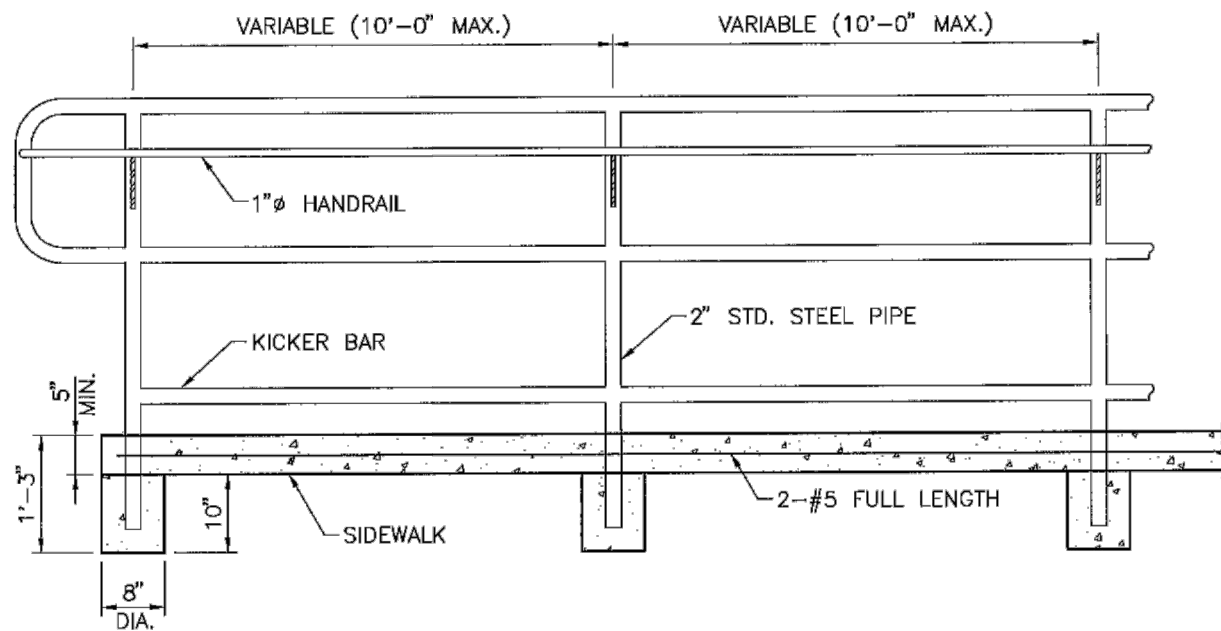

SCHEME # 2
(VIEW Y-Y)

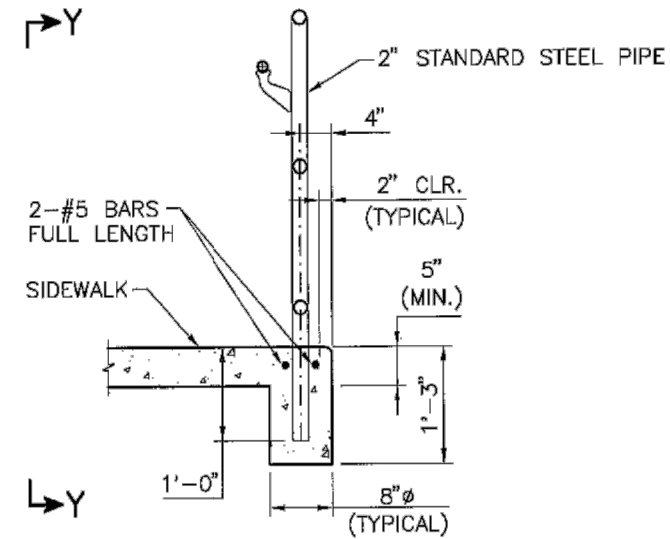

FOUNDATION SCHEME # 2
(FOR EDGE OF SIDEWALK INSTALLATION)

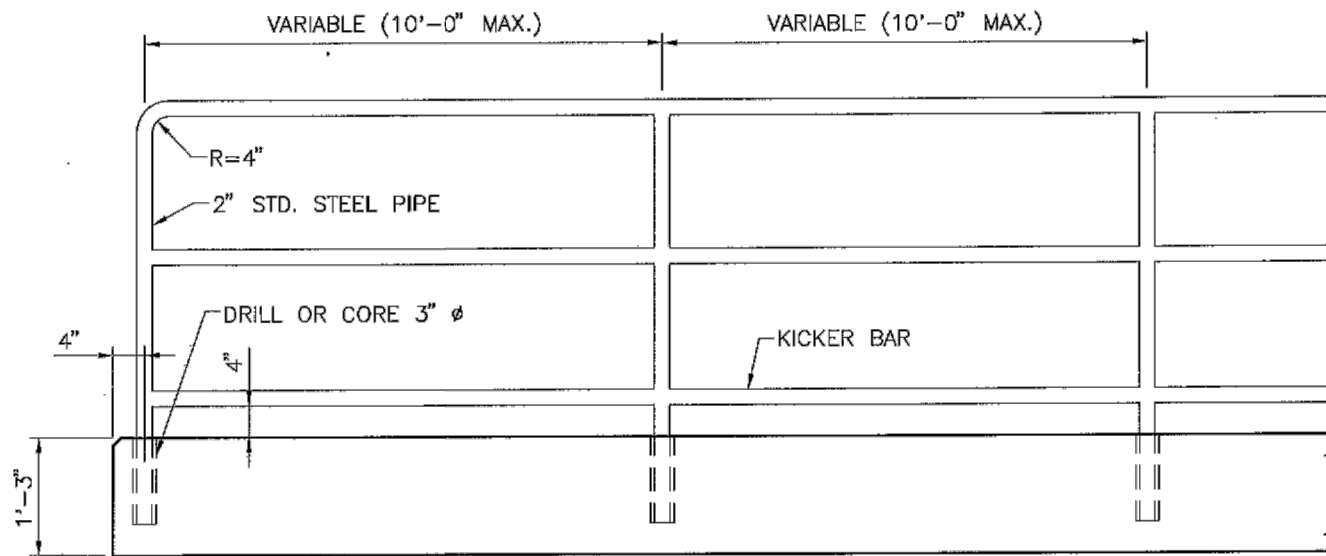

SCHEME # 1
(VIEW X-X)

NOTE: HANDRAILING OMITTED FROM VIEW. REFER TO GENERAL NOTE 7 ON DRAWING 607-20-1/4 WHEN HANDRAILING IS REQUIRED.

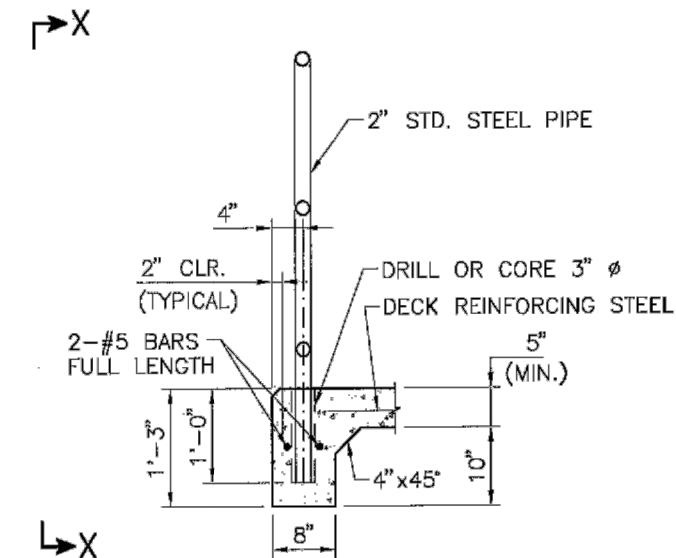

FOUNDATION SCHEME # 1
(FOR BRIDGE DECK OR EDGE OF SIDEWALK INSTALLATION)



DATE	BY	DESCRIPTION

REVISIONS (OR CHANGE NOTICES)

NEW MEXICO
DEPARTMENT OF TRANSPORTATION
STANDARD DRAWING

PEDESTRIAN RAILING
FOUNDATION DETAILS

DESIGNED BY: TM DRAWN BY: SKL CHECKED BY: YML/TM
607-20-3/4 3 of 4