

Dena W Cone
Purchasing Agent

Kenneth F. Waggoner Building
201 Johnston Street, 2nd Floor
Saint George, SC 29477
Telephone: 843.563.0140



Request for Quotes
No. 2023-08

2022 NiftyLift TM34TG

PROJECT OVERVIEW (See Specifications for details)

SOLICITATION NUMBER: RFQ No. 2023-08
DESCRIPTION OF SUPPLIES: 2022 NiftyLift TM34TG
DEADLINE FOR QUOTE SUBMISSION: Friday, July 15, 2022 @ 5:00PM Eastern

QUOTES SHOULD BE EMAILED TO:

Dena Cone, Purchasing Agent
dcone@dorchestercountysc.gov

OR SUBMITTED ONLINE THROUGH ELECTRONIC SOLICITATION AT

<https://vrapp.vendorregistry.com/Bids/View/BidsList?BuyerId=e18973c1-4a13-4b63-a74f-feebcba670c0>

SPECIFICATIONS

34' platform height, 40' work height, 20' horizontal reach, Honda gas engine with hydraulic outriggers and stabilizers, must include a spare tire, power to perform. Please see next page for spec sheet.

This equipment must be available for pickup within 15 days from the close of the RFQ.



Bid Amount : \$ _____

Authorized Signature _____

Company Name: _____

Address: _____

City, State, Zip: _____

Phone/Fax No.: _____

Comments: _____

niftylift

TM34T



(A) 40ft



(B) 33ft 6in



(C) 20ft



440lbs



3ft 7in x 2ft 2in



(D) 6ft 3in



(F) 4ft 11in



(G) 11ft 8in



(J) 14ft 9in



Option



3110lbs



11%
6°

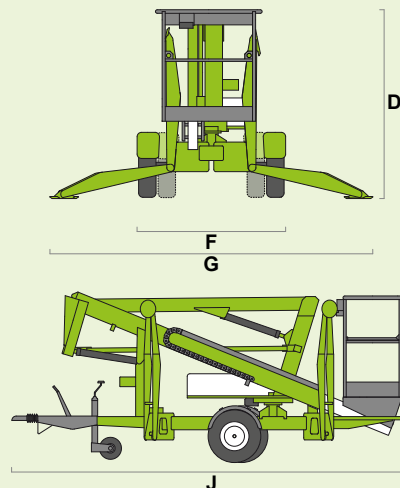
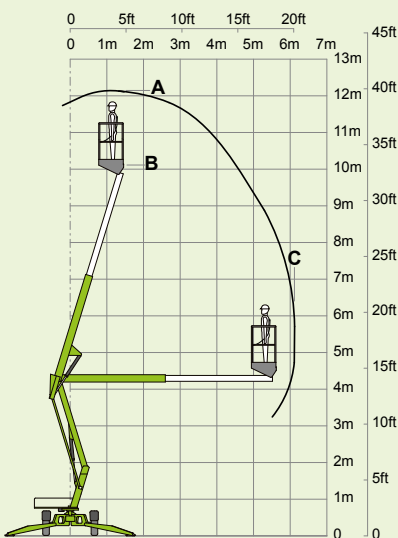

niftylift



Payment

Contractor shall invoice Dorchester County after pickup of equipment. Payment will be made within thirty (30) days from the date of invoice approval.

Award

The lowest quote that meets all requirements, as verified by the County Facilities Management Director, will be issued a purchase order that represents a contract between the County and the vendor. Acceptance of the purchase order by the vendor indicates acceptance of these RFQ terms and conditions as the contractual terms and conditions of this purchase.

REQUEST FOR QUOTES (RFQ) GENERAL TERMS AND CONDITIONS

1. PREPARATION, SUBMISSION AND WITHDRAWAL OF QUOTES

- A. This solicitation is being issued in accordance with the Dorchester County Procurement Policies. All proposers, and all associated sub-consultants as deemed necessary, shall be able to be properly licensed to conduct its business in Dorchester County, with all licenses, permits, and certificates as required by all local, State of South Carolina, and Federal agencies.
- B. Quotes may be electronically submitted via the Vendor Registry website; however, Dorchester County is not responsible if submissions are not received due to website errors.
- C. **Quotes submitted after the due date and time are considered “Late Quotes,” and will not be opened or considered.**
- D. Quotes may be withdrawn by written request received from the Contractor prior to the time set for opening of quotes, but not thereafter.
- E. Dorchester County reserves the right to make any changes to this RFQ, or to reject any and all quotes, or parts of any and all quotes or to accept any quote or portion thereof deemed to be in the best interest of the County, or postpone or cancel, at any time, this RFQ, or to re-solicit this RFQ, or to waive any irregularities in this RFQ or in the quotes received as a result to this RFQ. Dorchester County also reserves the right to request clarification or information from any proposer. The County is not liable for any expenses incurred by any firm as a result of being a respondent to this solicitation.
- F. Any interpretation, correction or change of the RFQ documents will be made by addendum.
It is your responsibility to monitor the Procurement website by selecting Quotes/RFQ Opportunities at www.dorchestercountysc.gov for any additional information, revisions, or addenda that may be posted.
- G. No substitutions will be considered after the Contract award except by amendment or change order.

2. CONTRACTOR REPRESENTATIONS

Each Contractor by submitting a quote represents that:

- A. The Contractor has read and understands this RFQ (including all specifications, attachments, and addenda) and that their quote is made in accordance therewith.
- B. The Contractor has reviewed the RFQ, has become familiar with the local conditions under which the Work is to be performed, and has correlated personal observations with the requirements of the proposed Contract Documents.
- C. The quote is based on the terms, materials, systems and equipment required by this RFQ, without exception.
- D. The Contractor is qualified to provide the services and equipment required under this RFQ and, if awarded the Contract, will do so in a professional, timely manner using Contractor's best skill and attention.

3. AWARD OF CONTRACT

- A. The contract will be awarded to the most responsive and responsible firm meeting the specifications of the County. Although cost will be a consideration, the award will be based on cost, consistent with the desired quality of service needed for effective use.
- B. The County reserves the right to 1) reject any or all quotes and any part of a quote; 2) waive informalities, technical defects, and minor irregularities in quotes received.
- C. The County shall be the sole judge of the suitability of the items or services to be provided pursuant to this RFQ.

4. INDEMNIFICATION

Except for expenses or liabilities arising from the negligence or intentional acts of the County, the Contractor hereby expressly agrees to indemnify and hold the County harmless against any and all expenses and liabilities arising out of the negligent performance, action or inaction of the Contractor in conduct of this Contract, as follows:

For matters other than those arising from the rendering or failure to render professional services, the Contractor expressly agrees to the extent that there is a causal relationship between its negligence, action or inaction, or the negligence, action or inaction of any of its employees or any person, firm or corporation directly or indirectly employed by the Contractor and any damage, liability, injury, loss or expense (whether in connection with bodily injury or death or property damage) that is suffered by the County and/or its officers or employees or by any member of the public, to indemnify and save the County and its officers and employees harmless against any and all liabilities, penalties, demands, claims, lawsuits, losses, damages, costs, and expenses arising out of the negligence, action or inaction of the Contractor, regardless of whether such liabilities, penalties, demands, claims, lawsuits, losses, damages, costs and expenses are caused in part by the County. Such costs are to include, without limitation, defense, settlement and reasonable attorney's fees incurred by the County and its employees. This promise to indemnify shall include, without limitation, bodily injuries or death occurring to the Contractor's employees and any person, directly or indirectly employed by the Contractor (including, without limitation, any employee of any subcontractor), the County's officers or employees, the employees of any other independent contractors, or occurring to any member of the public. When the County submits notice, the Contractor shall promptly defend any aforementioned action.

For matters arising out of the rendering or failure to render professional services, the Contractor will indemnify and save the County and its officers and employees harmless from and against all liabilities, penalties, demands, claims, lawsuits, losses, damages, costs and expenses arising out of or resultant

from any negligent act, error or omission of the Contractor in the rendering or failure to render professional services under this Contract. Such costs are to include, without limitation, defense, settlement and reasonable attorneys' fees incurred by the County and its officers and employees. This promise to indemnify shall include, without limitation, bodily injuries or death occurring to the Contractor's employees and any person, directly or indirectly employed by the Contractor (including, without limitation, any employee of any subcontractor), the County's officers or employees, the employees of any other independent contractors, or occurring to any member of the public. When the County submits notice of claim that triggers the indemnity, the Contractor shall promptly defend any aforementioned action at its own cost.

The limits of insurance required in this Contract shall not limit the Contractor's obligations under this Section. The terms and conditions contained in this Section shall survive the termination of the Contract or the suspension of the Work hereunder. To the extent that any liabilities, penalties, demands, claims, lawsuits, losses, damages, costs and expenses are caused in part by the acts of the County, the Contractor's obligations shall be reduced in proportion to the County's fault. The obligations herein shall also extend to any actions by the County to enforce this indemnity obligation. The recovery of costs and fees all extend to those incurred in the enforcement of this indemnity.

5. STATE AND LOCAL TAXES

Except as otherwise provided, Quotes shall *include* all applicable state and local taxes.

The successful Contractor shall calculate that portion of the Contract which is subject to the seven percent (7%) sales and/or use tax, which amount shall be itemized and shown on all invoices, and shall be paid to South Carolina Department of Revenue (SCDOR) by Contractor. If the successful Contractor is a non-South Carolina company, the County will withhold said amount from all invoices and remit payment to the SCDOR, unless the Contractor furnishes County with a valid South Carolina Use Tax Registration Certificate Number.

The successful Contractor shall indemnify and hold harmless the County for any loss, cost, or expense incurred by, levied upon or billed to the County as a result of the successful Contractor's failure to pay any tax of any type due in connection with this Contract.

The successful Contractor shall ensure that the above sections are included in all subcontracts and sub- subcontracts, and shall ensure withholding on out of state sub and sub-subcontractors to which withholding is applicable.

6. DRUG-FREE WORKPLACE ACT

By submitting a quote, Contractor certifies that, if awarded a contract, Contractor will comply with all applicable provisions of the Drug-Free Workplace Act, Title 44, Chapter 107 of the South Carolina Code of Laws, as amended.

7. INSURANCE REQUIREMENTS

The successful Contractor shall procure, maintain, and provide proof of, insurance coverage for injuries to persons and/or property damage as may arise from or in conjunction with, the work performed on behalf of the County by the Contractor, his agents, representatives, employees or subcontractors.

A. Coverage Provisions

- a. All deductibles or self-insured retention shall appear on the certificate(s).
- b. The County of Dorchester, its' officers/ officials, employees, agents and volunteers shall be added as "additional insured" as their interests may

appear. This provision does not apply to Professional Liability or Workers' Compensation/Employers' Liability.

- c. The Contractor's insurance shall be primary over any applicable insurance or self-insurance maintained by the County.
- d. Shall provide 30 days written notice to the County before any cancellation, suspension, or void of coverage in whole or part, where such provision is reasonable.
- e. All coverage for subcontractors of the Contractor shall be subject to all of the requirements stated herein.
- f. All deductibles or self-insured retention shall appear on the certificate(s) and shall be subject to approval by the County. At the option of the County, either; the insurer shall reduce or eliminate such deductible or self-insured retention; or the Contractor shall be required to procure a bond guaranteeing payment of losses and related claims expenses.
- g. Failure to comply with any reporting provisions of the policy(s) shall not affect coverage provided the County, its officers/officials, agents, employees and volunteers.
- h. The insurer shall agree to waive all rights of subrogation against the County, its' officers/officials, agents, employees or volunteers for any act, omission or condition of premises which the parties may be held liable by reason of negligence.

The Contractor shall furnish the County certificates of insurance including endorsements affecting coverage. The certificates are to be signed by a person authorized by the insurance company(s) to bind coverage on its' behalf, if executed by a broker, notarized copy of authorization to bind, or certify coverage must be attached.

8. **INSPECTION**

The purchased commodities shall be subject to inspection and test by the County upon delivery. The Contractor shall, without charge, correct any workmanship found by the County not to conform to the RFQ requirements.