

PUBLIC NOTICE
INVITATION TO BID #1265

The Springfield Electric Department will be accepting sealed bids for the following:

**Two (2) 69kV Circuit Breakers for the Springfield Electric District
Substation Facility**

Specifications and bid requirements may be downloaded at www.springfieldtn.gov.

All questions or inquiries regarding this bid should be directed to:

Gresham Smith
Contact: Scott Ribble, P.E. or Jeff Prentiss, P.E.
222 Second Avenue South
Suite 1400
Nashville, TN 37201
(615)770-8100

Please reference **BID NUMBER 1265** on the outside of the sealed envelope. Sealed bids must be received in the Office of the City Recorder, 405 North Main Street, Springfield, TN 37172 by 10:45 AM local time, Thursday, November 30, 2023.

The City of Springfield reserves the right to reject any or all bids and to waive any informalities or technicalities therein. Bids must be lump sum, and no bidder may withdraw his bid for a period of sixty (60) days after date of actual bid opening without the City of Springfield's consent.

Lisa H. Crockett
City Recorder

Section 00 1116 - Page 1 of 1

Sealed proposals for two (2) 69kV Circuit Breakers for the Springfield Electric District Substation facility will be received until 10:45 am Central Time on November 30, 2023, and immediately thereafter will be opened reviewed.

Proposals shall be received by:

Office of the City Recorder
405 N. Main Street
Springfield, TN 37172

All questions or inquiries concerning this bid should be directed to:

Gresham Smith
222 Second Avenue South, Suite 1400 Nashville, Tennessee 37201
Phone: (615) 770-8100
Primary Contact: Scott Ribble, P.E.
Secondary Contact: Jeff Prentiss, P.E

The Owner reserves the right to reject any or all bids and to waive any informalities or technicalities therein. Bids shall be Lump Sum.

No Bidder may withdraw his bid for a period of sixty (60) days after date of actual bid opening, without Owner's consent.

END OF SECTION

© 2018 Gresham Smith. All rights reserved. Use subject to any written agreement with Gresham Smith.

1.1 DEFINED TERMS.

- A. Terms used in these INSTRUCTIONS TO BIDDERS have the meanings assigned to them in the GENERAL CONDITIONS.

1.2 EXAMINATION OF CONTRACT DOCUMENTS AND SITE.

- A. It is the responsibility of each Bidder before submitting a Bid, to (a) examine the Contract Documents thoroughly, (b) visit the site to become familiar with the local conditions that may affect cost, progress, performance or furnishing of the Work, (c) consider federal, state and local Laws and Regulations that may affect cost, progress, performance or furnishing of the Work, (d) study and carefully correlate Bidder's observations with the Contract Documents, and (e) notify Engineer of all conflicts, errors or discrepancies in the Contract Documents.
- B. The Proposal provides for quotation of a price for one or more Bid Items, which may be lump sum prices, alternate Bid prices, or a combination thereof. No payment will be made for any Items not set up in the Proposal, unless otherwise provided by a Contract Amendment. All Bidders are cautioned that they should include in the prices quoted for the various Bid Items, all necessary allowances for the performance of all work required for the satisfactory completion of the Project.

1.3 BIDDING REQUIREMENTS

- A. Bidder will submit two (2) copies of Section 00 4143 – BID FORM and all supporting documents specified.
- B. Bids that are sent by U.S. Postal Service or private carrier, shall be clearly marked “**BID ENVELOPE ENCLOSED BID NUMBER 1265**”. The Bid shall be sealed in a separate envelope and shall have the following information shown on the outside of the envelope:

BID FOR: SPRINGFIELD ELECTRIC DISTRICT SUBSTATION BID NUMBER 1265
BID DUE: NOVEMBER 30, 2023
OWNER: SPRINGFIELD ELECTRIC

- C. As an alternative option, the Label provided in Section 00 4140 – BID FORM ENVELOPE LABEL can be filled out and secured to the outside of the envelope.

- D. The Engineer for this project is:

Gresham Smith
222 Second Avenue South, Suite 1400
Nashville, Tennessee 37201
Phone: (615) 770-8100
Primary Contact: Scott Ribble, P.E.
Secondary Contact: Jeff Prentiss, P.E.

1.4 CHECKLIST FOR BIDDERS.

- A. Submit two (2) copies of Section 00 4143 – BID FORM, and verify the following information has been included as required:
 - a. Date
 - b. Bid Price
 - c. Delivery Site and Date
 - d. Alternative Delivery Date
 - e. Required Submittal Data
 - f. Addenda (if any)
 - g. Exceptions to the Specifications (if any)
 - h. Iran Divestment Act Notice ****Must be Signed/Dated and returned in bid submittal****
 - i. Signature

END OF SECTION

1.1 GENERAL

- A. This form is for the Bidder’s convenience as noted in Section 00 2113 – INSTRUCTIONS TO BIDDERS.

This form is not required, however, **the information IS required on the front of the Bid Envelope.**

PROJECT: _____

OWNER: _____

ADDRESS: _____

BIDDER IDENTIFICATION

BIDDER: _____

ADDRESS: _____

BIDDER’S CONTRACTOR’S LICENSE INFORMATION

LICENSE NUMBER: _____

LICENSE CLASSIFICATION APPLICABLE TO PROJECT: _____

LICENSE EXPIRATION DATE: _____ DOLLAR LIMIT: _____

SUBCONTRACTORS TO BE USED ON THIS PROJECT

Provide following for each listed subcontractor or so designate if Bidder is providing the Work Classification.
Indicate “NONE” if Work Classification is not applicable.

| Type of Work | License No. | Expires | Classification |
|--------------|-------------|---------|----------------|
| | | | |

- B. Cut and tape securely to front of Bid Envelope. **The Bid Envelope shall be separate from the postal/ mailing/ delivery service Deliver Envelope (when delivery envelope is required. See also INSTRUCTIONS TO BIDDERS).**

END OF SECTION

Bid Number 1265

BID FORM

Section 00 4143 - Page 1 of 5

Project Identification: Springfield Electric District Substation

This Bid shall be submitted as follows:

By Regular Mail, In Person, or By Overnight Delivery:

Office of the City Recorder
405 N. Main Street
Springfield, TN 37172

This Bid is submitted from:

Contractor Name: _____

Address: _____

City, State, Zip: _____

The undersigned Bidder proposes and agrees, if this Bid is accepted, to enter into an agreement with Owner in the form included in the Contract Documents to sell and deliver the material described in these Specifications, for the Price and within the Time indicated in this Bid and in accordance with other terms and conditions of the Contract Documents.

BASE BID:

| ITEM | QTY | DESCRIPTION | UNIT BID PRICE | TOTAL BID PRICE |
|------|-----|---------------------------------|----------------|-----------------|
| 1 | 2 | 69Kv Substation Circuit Breaker | | |
| | | | | |
| | | | | |
| | | | | |

PROJECT LOCATION AND SCHEDULE:

Delivery Site: Josephine Street & Industrial Drive
Springfield, Tennessee

Delivery Period: August 1, 2025

Completion Date: January 1, 2026

Site Conditions: Substation Circuit Breakers will be delivered to substation under construction and off-loaded on prepared foundation(s).

Section 00 4143 - Page 2 of 5

An alternate Delivery Date of _____ is proposed by the Bidder. If this alternate Delivery Date is accepted by the Owner, a bid price **DEDUCT per unit** of \$ _____ is offered.

The Bidder shall provide shop drawings, as specified in Section 33 7230, Section 1.5.B, _____ weeks after receipt of order.

The Bidder shall provide "FOR CONSTRUCTION" drawings at least **four (4) weeks** prior to shipping.

GENERAL:

In submitting this BID FORM, the Bidder agrees as follows:

The prices set forth herein do not include any sums which are or may be payable by the Bidder on account of taxes imposed by any taxing authority upon the sale, purchase, or use of the equipment. If any such tax is applicable to the sale, purchase, or use of the equipment, the amount thereof shall be added to the purchase price and paid by the Owner.

The prices set forth herein are firm if accepted by the Owner within **forty-five (45) days** and shall include the cost of:

1. Delivery to the job site.
2. Offloading onto an Owner furnished foundation(s).
3. Field inspection, testing, and certification.
4. All other labor or other cost to provide the Owner with transformer filled with oil and ready for external connection.

The metal clad medium voltage switchgear shall be delivered to the Delivery Site during the Delivery Period specified above. The Delivery Period defines the time during the project schedule from completion of the concrete pad until other project tasks could make the pad inaccessible. Delivery outside the specified Delivery Period could result in liquidated damages being assessed.

The Bidder shall be responsible for securing all permits required for shipping to the Delivery Site and shall be responsible for any damages to road and utilities or other damages caused by the Bidder or his Delivery Agent during shipment to Delivery Site.

Notice of Shipment - The Bidder shall notify the Owner at the following times:

1. 10 days prior to shipment.
2. 24 hours prior to shipment.
3. 24 hours prior to delivery.

Shipments arriving after 2:00 p.m. on weekdays or arriving on weekends or holidays shall not be offloaded until the next working day and the Bidder shall be responsible for any demurrage.

Failure to provide notice shall result in Bidder being responsible for any demurrage charges resulting from the unavailability of equipment to unload equipment.

Section 00 4143 - Page 3 of 5

The Bidder agrees that all requests for time extensions shall be in writing, and that only such time extensions as are granted by the Owner in writing shall be considered.

Time is of the essence in order for the Owner to comply with established construction schedules. Should the Bidder fail to complete the terms of this BID FORM by the Completion Date, after all time extensions granted by the Owner have been added, then in that event the Owner shall have and is hereby given the right to deduct and retain out of such monies which may then be due, or which may become due and payable to the Bidder, the DAMAGE AMOUNT per calendar day as liquidated damages for each and every day that Certification is delayed beyond the Completion Date. The Bidder and Owner agree that liquidated damages are for costs associated with project delay and not as a penalty and that proof of such losses or damages shall not be required. The DAMAGE AMOUNT shall be \$_____ per day.

The qualifications of the Bidder's Field Services Representative for field inspection, testing and certification shall be attached to this BID FORM. Include the name of the proposed field service firm, if these services are not supplied by employees of the manufacturer. A schedule of field tests, if different from those specified in 33 7230, shall be submitted by the Bidder. The qualifications of the Field Service Representatives or Field Service Firm will be included in the overall evaluation of this BID FORM.

In estimating the lowest cost to the Owner as one of the factors in deciding the award of an order, the Owner will consider, in addition to the price quoted in the BID FORM, the following:

1. Stated exceptions to the specifications.
2. Method of delivery.
3. Warranty.
4. Installation, erection and operating costs.
5. Delivery time.
6. Work history on previous projects.

The bid prices submitted for spare parts will not be used in the evaluation.

Failure to submit bid evaluation data as specified can lead to bid rejection.

Title of each equipment item shall pass to the Owner upon:

1. Delivery and placement of equipment onto foundation at location specified.
2. Satisfactory inspection for in transit damage.
3. Satisfactory installation and field test by the Materialman's Field Services Representative and Certification that the unit is ready to place in service.
4. Acceptance by the Owner following completion of Item 3.
5. Payment: See Section 00 5262 – AGREEMENT FORM.

The Bidder shall submit bids on this BID FORM. Submit complete BID FORM in (2) two unaltered copies with all blank spaces completed. There shall be no exceptions for basic bid submitted by the Materialman; however, an alternate, with exceptions, may be bid as an attachment to a basic bid.

Bid Number 1265

BID FORM

Section 00 4143 - Page 5 of 5

It is understood by the undersigned that the Owner retains the privilege of accepting or rejecting all or any part of this BID FORM and to waive any informalities or technicalities therein.

BIDDER: _____

BY: _____

TITLE: _____

DATE: _____

MAILING ADDRESS: _____

STREET ADDRESS: _____

TELEPHONE: _____

FAX: _____

PRIMARY CONTACT: _____

ALTERNATE CONTACT: _____

END OF SECTION

1.1 SECTION INCLUDES

- A. Submittal Procedures
- B. Construction and Progress Schedules

1.2 RELATED SECTIONS

- A. Section 01 3323 – SHOP DRAWINGS
- B. Section 01 7839 – PROJECT RECORD DOCUMENTS

1.3 SUBMITTAL PROCEDURES

- A. Transmit each submittal with transmittal letter or Engineer accepted form. Sequentially number the transmittal forms. Resubmittals to have original number with an alphabetic suffix.
- B. Submit shop drawings as specified in Section 01 3323 - SHOP DRAWINGS.
- C. Identify project, Contractor, subcontractor or supplier; pertinent drawing sheet and detail number(s), and specification section number, as appropriate.
- D. Schedule submittals to expedite the project, and deliver to Engineer with copy of transmittal letter to Owner's representative as identified in Section 01 3113 - PROJECT COORDINATION.
- E. Identify variations from Contract Documents and product or system limitations which may be detrimental to successful performance of the completed Work.
- F. Provide space for Contractor and Engineer review stamps.
- G. Revise and resubmit submittals as required, identify all changes made since previous submittal.
- H. Distribute copies of reviewed submittals to concerned parties. Instruct parties to promptly report any inability to comply with provisions.

1.4 SUBMITTAL SCHEDULE

- A. Provide schedule for project submittals in accordance with the specifications and as agreed to by Engineer and Contractor.

1.5 CONSTRUCTION AND PROGRESS SCHEDULE

- A. Submit initial progress schedule in duplicate within 30 days after date established in Notice to Proceed for Architect/Engineer review.
- B. Revise and resubmit as required.

Section 01 3219 - Page 2 of 2

- C. Submit revised schedules with each Application for Payment, identifying changes since previous version.
- D. Submit computer generated network analysis diagram using the critical path method, generally as outlined in Associated General Contractors of America (AGC) publication "The Use of CPM in Construction - A Manual for General Contractors and the Construction Industry".
- D. Show complete sequence of construction by activity, identifying Work of separate stages and other logically grouped activities. Indicate the early and late start, early and late finish, float dates, and duration.
- E. Indicate estimated percentage of completion for each item of Work at each submission.
- F. Indicate submittal dates required for shop drawings, product data, samples, and product delivery dates, including those furnished by Owner and under Allowances.

END OF SECTION

1.1 SECTION INCLUDES

- A. Submit Shop Drawings and product data required by contract documents.

1.2 RELATED SECTIONS

- A. DIVISIONS 0 and 1 – PROCUREMENT AND CONTRACTING REQUIREMENTS and GENERAL REQUIREMENTS: These shall apply to all work included in this section.
- B. Section 01 3219 – SUBMITTALS
- C. Section 01 7839 – PROJECT RECORD DOCUMENTS

1.3 SHOP DRAWINGS

- A. Shop drawings shall include: fabrication information; material lists; manufacturer's catalog sheets and/or descriptive data, showing dimensions, performance characteristics, and capacities; electrical characteristics, and capacities; and other pertinent information as required to obtain approval of the items involved.
- B. Drawings shall be presented in a clear and thorough manner.
 - 1. Details shall be identified by reference to sheet and detail numbers shown on Contract Drawings and Specification Sections.

1.4 PRODUCT DATA

- A. Preparation:
 - 1. Clearly mark each copy to identify pertinent products or models.
 - 2. Show dimensions and clearances required.
- B. Manufacturer's standard drawings and diagrams:
 - 1. Modify drawings and diagrams to delete information which is not applicable to the Work.
 - 2. Supplement standard information to provide information specifically applicable to the Work.

1.5 CONTRACTOR RESPONSIBILITIES

- A. Designate in the construction schedule, or in a separate coordinated schedule, the dates for submission and the dates that reviewed Shop Drawings and product data will be required to maintain construction schedule.

- B. Review Shop Drawings and Product Data prior to submission.
- C. Contractor is responsible for review of all Subcontractor and supplier submittals.
- D. Determine and verify:
 - 1. Field measurements
 - 2. Field construction criteria
 - 3. Catalog numbers and similar data
 - 4. Conformance with specifications
- E. Coordinate each submittal with requirements of the Work and of Contract Documents.
- F. Notify the Owner/Engineer in writing, at time of submission, of any deviations in the submittals from requirements of the Contract Documents.
- G. Begin no fabrication or work which required submittals until return of submittals with satisfactory review.

1.6 SUBMISSION REQUIREMENTS

- A. Make submittals promptly in accordance with approved schedule, and in such sequence as to cause no delay in the work or in the work of any other contractor.
- B. Number of submittals required:
 - 1. Shop Drawings: Submit three (3) paper copies of shop drawings of all items for which shop drawings are specified in other sections, and for all major equipment items.
 - 2. Product Data: Submit three (3) copies of product data of all items for which product data is specified in other sections and for all major items.
 - 3. One (1) copy of electronic data files of all drawings prepared for the project. Format shall be either CAD format (.DGN or .DWG), or PDF format. Media shall be CD-ROM.
- C. Submittals shall contain:
 - 1. Submittal identification number. Submittals shall be numbered consecutively. Re-submittals shall use the same submittal number with an alphabetic suffix added.
 - 2. The date of submission and the dates of any previous submissions.
 - 3. The project title and number.

4. The names of:
 - a. Contractor
 - b. Subcontractor
 - c. Supplier
 - d. Manufacturer
5. Identification of the project, with the specification section number.
6. Field dimensions, clearly identified as such.
7. Relation to adjacent or critical features of the work or materials.
8. Applicable standards, such as ASTM or Federal Specification numbers.
9. Identification of deviations from Contract Documents.
10. Identification of revisions on resubmittals.
11. An 8"x3" blank space for Contractor and Engineer stamps.
12. Contractor's stamp, initialed or signed, certifying to review of submittal, verification of products, field measurements and field construction criteria, and coordination of the information within the submittal with requirements of the Work of Contract Documents.

1.7 RETURN FOR RE-SUBMISSION

- A. The Engineer will return for resubmission all shop drawings submitted without the above specified approval and certification which in the Engineers opinion contain numerous discrepancies, have not been checked, or do not meet the requirements for submission.

1.8 REVIEW OF SUBMITTALS

- A. The Engineer will review, mark and date all submitted shop drawings. Two (2) sets will be returned to the Contractor and remaining sets will be retained by the Engineer. Contractor shall make corrections and changes as indicated.
- B. Resubmit shop drawings as specified above, until satisfactory review has been obtained. Corrections and/or changes indicated on shop drawings by Engineer/Owner shall not be considered as an extra work order.
- C. After satisfactory "Review" or "Furnish as Corrected" has been obtained for all shop drawings, three (3) copies of shop drawings marked "FOR CONSTRUCTION" shall be furnished to the Owner/Engineer within 21 days of receipt of approval drawings by Contractor. Format of electronic data files shall be as specified in Article 1.06, above.

- D. Review of shop drawings by the Owner/Engineer will be general only, and such review will not relieve the Contractor of responsibility for accuracy of such shop drawings, proper fitting, coordination, construction of work, and furnishing materials required by the Specifications but not indicated on shop drawings. Review of shop drawings shall not be construed as approving departures from the Specifications.

1.9 DISTRIBUTION

- A. Distribute copies of Shop Drawings and copies of Product Data which carry the Engineer stamp of approval to:
 - 1. Job site file
 - 2. Record Documents File
 - 3. Other affected contractors
 - 4. Subcontractors
 - 5. Supplier or fabricator

1.10 OWNER / ENGINEER DUTIES

- A. Review submittals with reasonable promptness and in accordance with schedule.
- B. Affix stamp and initials or signature, and indicate requirements for resubmittal, or satisfactory review of submittal.
- C. Return submittals to Contractor for distribution, or for resubmission.

END OF DOCUMENT

PART 1 GENERAL**1.1 SECTION INCLUDES**

- A. Record of changes
- B. Final "As-Built" drawings
- C. Operation and maintenance manuals

1.2 RELATED SECTIONS

- A. DIVISIONS 0 and 1 – PROCUREMENT AND CONTRACTING REQUIREMENTS and GENERAL REQUIREMENTS: These shall apply to all work included in this section.
- B. Other requirements affecting Project Record Documents may appear in pertinent other Sections of these Specifications.

1.3 SUBMITTALS

- A. Comply with pertinent provisions of Section 01 3219 - SUBMITTALS
- B. The Engineer's approval of the current status of Project Record Documents may be a prerequisite to the Engineer's approval of requests for progress payment and request for final payment under the Contract.
- C. Prior to submitting each request for progress payment, secure the Engineer's approval of the current status of the Project Record Documents.
- D. Prior to submitting request for final payment, submit the final Project Record Documents to the Engineer for approval.

1.4 QUALITY ASSURANCE

- A. Delegate the responsibility for maintenance of Record Documents to one person on the Contractor's staff as approved by the Engineer.
- B. Accuracy of records:
 - 1. Thoroughly coordinate changes within the Record Documents, making adequate and proper entries on each page of Specifications and each sheet of Drawings and other Documents where such entry is required to show the change properly.
 - 2. Accuracy of records shall be such that future search for items shown in the Contract Documents may rely reasonably on information obtained from the approved Project Record Documents.

PROJECT RECORD DOCUMENTS

Section 01 7839 - Page 2 of 5

- C. Make entries within 24 hours after receipt of information that the change has occurred.

1.5 DELIVERY, STORAGE, AND HANDLING

- A. Maintain the job set of Record Documents completely protected from deterioration and from loss and damage until completion of the Work and transfer of all recorded data to the final Project Record Documents.
- B. In the event of loss of recorded data, use means necessary to again secure the data to the Engineer's approval.
 - 1. Such means shall include, if necessary in the opinion of the Engineer, removal and replacement of concealing materials by Contractor at his cost.
 - 2. In such case, provide replacements to the standards originally required by the Contract Documents by Contractor at his cost.

PART 2 PRODUCTS**2.1 RECORD DOCUMENTS**

- A. Job set: Promptly following the Effective Date of Agreement secure from the Engineer at no charge to the Contractor one complete set of all Documents comprising the Contract.

PART 3 EXECUTION**3.1 MAINTENANCE OF JOB SET**

- A. Immediately upon receipt of the job set described in Paragraph 2.01-A above, identify each of the Documents with the title, "RECORD DOCUMENTS - JOB SET."
- B. Preservation:
 - 1. Considering the Contract completion time, the probable number of occasions upon which the job set must be taken out for new entries and for examination, and the conditions under which these activities will be performed, devise a suitable method for protecting the job set to the approval of the Engineer.
 - 2. Do not use the job set for any purpose except entry of new data and for review by the Engineer, until start of transfer of data to final Project Record Documents.
 - 3. Maintain the job set at the site of Work as that site is designated by the Engineer.
- C. Making entries on Drawings:

PROJECT RECORD DOCUMENTS

Section 01 7839 - Page 3 of 5

1. Using an erasable colored pencil (not ink or indelible pencil), clearly describe the change by graphic line and note as required.
 2. Date all entries.
 3. Call attention to the entry by a "cloud" drawn around the area or areas affected.
 4. In the event of overlapping changes, use different colors for the overlapping changes.
- D. Make entries in the pertinent other Documents as approved by the Engineer.
- E. Drawings shall clearly show actual installed locations, depth, and sizes of:
1. Pipework of all descriptions below ground outside of building and structures, including locations of cleanouts, manholes, inlets, hydrants, and underground valves.
 2. Electrical conduits, electrical ducts, ground grid conductors, and directly buried conductors underground outside of buildings and structures, including locations of pull and junction boxes, electric manholes and handholes, pad mounted electrical equipment, utility poles, electrical outlets, and lighting fixtures.
- F. Conversion of schematic layouts:
1. In some cases on the Drawings, arrangements of conduits, circuits, piping, ducts, and similar items, is shown schematically and is not intended to portray precise physical layout.
 - a. Final physical arrangement is determined by the Contractor, subject to the Engineer's approval.
 - b. However, design of future modifications of the facility may require accurate information as to the final physical layout of items which are shown only schematically on the Drawings.
 2. Show on the job set of Record Drawings, by dimension accurate to within one inch, the centerline of each run of items such as are described in Article 3.01-E above.
 - a. Clearly identify the item by accurate note such as "cast iron drain," "galv. water," and the like.
 - b. Show, by symbol or note, the vertical location of the item ("under slab," "in ceiling plenum," "exposed," and the like).
 - c. Make all identification so descriptive that it may be related reliably to the Specifications.
 3. The Engineer may waive the requirements for conversion of schematic layouts where, in

PROJECT RECORD DOCUMENTS

Section 01 7839 - Page 4 of 5

the Engineer's judgment, conversion serves no useful purpose. However, do not rely upon waivers being issued except as specifically issued in writing by the Engineer.

- G. Review and submittal:
1. Submit the completed set of Project Record Documents to the Engineer as described in Paragraph 1.02-D above.
 2. Participate in review meetings as required.
 3. Make required changes and promptly deliver the Project Record Documents to the Engineer.

3.2 FINAL DRAWINGS

- A. At completion of project, the Contractor shall incorporate all revisions into the shop drawings to provide a complete set of final drawings. The drawings shall be marked as "Final-As Constructed".
- B. Submit three (3) paper copies of all shop drawings. Maximum size of all drawings is 22"x34".
- C. One (1) copy of electronic data files of all drawings prepared for the project. Format shall be CAD format (.DGN or .DWG) or PDF format. Media shall be CD-ROM.

3.3 OPERATION AND MAINTENANCE MANUALS

- A. The Contractor shall provide four (4) complete sets of Operations and Maintenance Manuals covering all equipment furnished for the project.
- B. Contents of Operations and Maintenance Manuals
 1. Manufacturer's technical literature; descriptive bulletins; installation, operation and maintenance instructions; and parts list.
 2. As-Constructed shop drawings.
 3. Certified factory test results.
- C. Format
 1. All Operations and Maintenance Manuals shall be bound in a three ring binder of suitable size (maximum 2") for the material to be inserted.
 2. Binders shall be white in color with clear jacket for the insertion of printed cover and edge identification sheets.

PROJECT RECORD DOCUMENTS

Section 01 7839 - Page 5 of 5

3. All information bound shall be 8½" x 11" or accordion folded to this size.
 4. Page dividers with plastic reinforced holes and tabs shall be used to organize Operations and Maintenance Manuals.
 5. Binder cover and edge inserts shall contain project name, date and subject matter of the manual.
- D. Organization
1. Table of Contents shall list all information contained.
 2. Contact information for all major equipment suppliers, Contractor, and subcontractors.
 3. Organize manual by equipment item. Contents as specified above.

3.4 FINAL SUBMITTAL

- A. All Record Documents including, job set, final drawings and Operation and Maintenance Manuals shall be submitted to Engineer prior to submitting final payment request.

3.5 CHANGES SUBSEQUENT TO ACCEPTANCE

- A. The Contractor has no responsibility for recording changes in the Work subsequent to Final Completion, except for changes resulting from work performed under Warranty.

END OF SECTION

PART 1. GENERAL**1.1 SECTION INCLUDES**

- A. This specification in conjunction with Section 33 7520D – DATA SHEET – POWER CIRCUIT BREAKER includes the fabrication and delivery of power circuit breaker(s), as required to meet the Contractor’s obligations, as stated in the proposal section of these specifications.

1.2 RELATED SECTIONS

- A. DIVISIONS 0 and 1 – PROCUREMENT AND CONTRACTING REQUIREMENTS and GENERAL REQUIREMENTS: These shall apply to all work included in this section
- B. Section 01 3219 – SUBMITTALS
- C. Section 01 3323 – SHOP DRAWINGS
- D. Section 01 7839 – PROJECT RECORD DOCUMENTS
- E. Section 33 7520D – DATA SHEET - POWER CIRCUIT BREAKER

1.3 REFERENCE STANDARDS

- A. Published Specifications, standards, tests, or recommended methods of trades, industry, or governmental organizations apply to work in this section and in the listing below.
 - 1. ANSI/IEEE C37.04 – Standard Rating Structure for AC High-Voltage Circuit Breakers Rated on a Symmetrical Current Basis.
 - 2. ANSI C37.06 - Standard for Switchgear – AC High-Voltage Circuit Breakers Rated on a Symmetrical Current Basis – Preferred Ratings and Related Required Capabilities.
 - 3. ANSI/IEEE C37.09 – Standard Test Procedure for AC High-Voltage Circuit Breakers Rated on a Symmetrical Current Basis.
 - 4. ANSI/IEEE C37.010 – Standard Application Guide for AC High-Voltage Circuit Breakers Rated on a Symmetrical Current Basis.
 - 5. ANSI/IEEE C37.11 – Requirements for Electrical Control for AC High-Voltage Circuit Breakers Rated on a Symmetrical Current Basis and a Total Current Basis.
 - 6. ANSI/IEEE C57.13 – Requirements for Instrument Transformers.
 - 7. NEMA SG4-2009 (R2013) – Alternating-Current High-Voltage Circuit Breakers.

1.4 SERVICE CONDITIONS

- A. Service conditions are shown on the DATA SHEET.

1.5 PROPOSAL REQUIREMENTS

- A. Certification of suitability of proposed materials for application on power system with the conditions of Article 1.4.
- B. Descriptive literature to be furnished with proposal shall include but not be limited to:
 - 1. Breaker Ratings:
 - a. Rated maximum voltage
 - b. Rated voltage range factor (k)
 - c. Rated short circuit current
 - d. Maximum symmetrical interrupting capability
 - e. Maximum asymmetrical interrupting capability
 - f. Percent of rating for specified reclosing duty cycle
 - 2. Outline dimension drawings with weights and anchor bolt layout
 - 3. Power supply requirements (Trip/close and motor start and run currents)
 - 4. Current transformer data
 - 5. Special tool requirements
 - 6. Time to charge spring operator mechanism
 - 7. Annual Maintenance requirements

1.6 SUBMITTALS

- A. Shop drawings shall be submitted for approval in accordance with Section 01 3219 – SUBMITTALS and Section 01 3323 – SHOP DRAWINGS.
- B. Submittals shall consist of, but not limited to, the following:
 - 1. Outline Dimension Drawing with Weights.
 - 2. Foundation Requirements:
 - a. Foundation loading and moment reactions for operational, wind, and seismic loading
 - b. Controlling load condition
 - c. Anchor bolt specifications (material) and layout
 - 3. Terminal Displacement/Deflection Information:
 - a. Wind
 - b. Seismic
 - 4. Seismic Qualification Report
 - 5. Schematics
 - 6. Power Supply requirements – as applicable
 - a. Spring Operator: Trip/close and motor start/run currents
 - b. Magnetic Operator: Steady State and Charging currents
 - 7. Wiring Connection Diagrams
 - 8. Current Transformer Data

POWER CIRCUIT BREAKER**Section 33 7520 - Page 3 of 12**

9. Bushing Data/Drawings
 10. Nameplate and Engraving Drawing
 11. Bill of Materials
 12. Installation Instructions
 13. Operating Instructions
 14. Final Certified Test Reports
- C. Final Drawings, Manuals, and Test Reports shall be provided prior to shipment in accordance with Section 01 7839 – PROJECT RECORD DOCUMENTS.

1.7 WARRANTY

- A. All materials and equipment supplied under this specification shall be warranted.

PART 2. PRODUCTS**2.1 ELECTRIC CHARACTERISTICS**

- A. The power circuit breaker equipment ratings are shown on the DATA SHEET.
- B. The power circuit breaker shall meet all of the specified ratings as defined in C37.04.

2.2 CONSTRUCTION

- A. General
1. The specified power circuit breaker shall be a Class S2 (outdoor), three-pole, dead-tank breaker providing three phase operation. The specified breaker shall withstand the service conditions specified on the DATA SHEET without damage to the insulation structure or mechanical operation.
- B. Bushings
1. Bushings shall have voltage and current ratings equal to or exceeding those specified for the breaker Electrical Characteristics shown on the DATA SHEET.
 2. Bushing shall meet or exceed the creepage distances recommended in C37.010 corresponding to the pollution level specified on the DATA SHEET. For breakers rated 15.5 kV, a minimum strike distance of 10 inches shall be maintained between the external “live parts” and the top of the metal enclosure.
 3. Bushings shall be porcelain, ANSI No. 70, Light Gray.
 4. Bushings shall be equipped with stud terminals and NEMA 4-hole tin-plated pads.
 5. Bushings shall also meet any special requirements shown on the DATA SHEET.

POWER CIRCUIT BREAKER**Section 33 7520 - Page 4 of 12****C. External Hardware**

1. All bolts, studs, nuts and lock washers used to mount bushings, cabinets, junction boxes, accessories and conduit shall be stainless steel. The Materialman's application should address potential galling.

D. Mechanism Housing

1. The housing containing the operating mechanism shall provide at least NEMA Class 3S protection, unless specified differently in the DATA SHEET. The housing shall be mounted so that any equipment inside the housing will be at least 18 inches above the foundation.
2. All housings shall have a hinged access door complete with handle-type latching mechanism with provision for locking with a padlock in a closed position. Provisions shall be included for maintaining the door in a fully opened position for maintenance within the housing.
3. To reduce condensation, each enclosure shall have a thermostatically controlled heater or a positive temperature coefficient (PTC) heater as shown on the DATA SHEET. Heaters shall meet the following requirements:
 - a. Heaters will be supplied from an Owner-furnished 120/240 Vac three-wire source and be connected at 240 Vac.
 - b. Non-PTC heaters shall be rated at 480 Vac.
 - c. The Materialman is responsible for determining the appropriate wattage for the application. When non-PTC heaters are supplied, the Materialman's shall consider heaters are being operated at 50% of their rated voltage.
 - d. When non-PTC heaters are supplied, heaters in areas subject to accidental contact shall be equipped with shields.
 - e. The supply circuit for heaters shall be separately fused (not connected to control fuses).
 - f. Non-PTC heaters shall be located such that residue from the heater will not fall onto breaker electrical, mechanical, or operating parts. Heaters shall not be located in a manner that will damage breaker wiring, relays, or other breaker materials. The heater shield shall not be painted or otherwise coated with any material that will give off fumes or residue when heated. Heater wiring shall utilize high temperature conductor insulation.

E. Position Indicators

1. An easily readable mechanical position indicator shall be furnished. The word "OPEN" in contrasting letters shall be displayed on a green background and the word "CLOSED" in contrasting letters shall be displayed on a red background.

POWER CIRCUIT BREAKER**Section 33 7520 - Page 5 of 12**

2. For spring-charged mechanisms, a mechanism indicator shall display the word "CHARGED" in black letters on a yellow background and the word "DISCHARGED" in black letters on a white background.

F. Grounding

1. The circuit breaker shall have two copper-faced steel or stainless steel pads welded on diagonally opposite bottom corners. The 2"x 3.5" ground pads shall have two holes horizontally spaced on 1.75" centers; drilled and tapped for 0.5" – 13 UNC Thread as defined in ANSI B1.1. The minimum thread depth of the holes shall be 0.5 inches. The minimum thickness for copper-facing (when used) shall be 0.016 inches.
2. When structural members are bolted together rather than welded, #4 AWG cables shall be connected internally to the ground pads to insure there are negligible differences in ground potential between compartments.
3. Fixed panels, swing panels and doors shall be intentionally grounded to the enclosure body with a flexible grounding strap.
4. A copper grounding bar shall be supplied for all necessary control and instrumentation grounding point attachments. Dimensions of the grounding bar shall be a minimum of 0.25" thick, 12" in length, and 1" in width.

G. Surface Preparation

1. All external surfaces of the specified breaker, including frames, tanks, operating mechanisms and other exposed parts, shall be weatherproofed and design to prevent the accumulation of moisture. Surfaces that require paint shall be shot-blasted, sand-blasted or chemically cleaned and given a minimum of two (2) coats of rust-inhibitive paint a minimum of three (3) mils in total thickness. Coating shall meet ASTM B117 Salt Spray requirements. Color of finish coat is shown on the DATA SHEET.

H. Support Frame

1. Adjustable support frame with extensions shall be provided as required to place bottom of high voltage bushings a minimum of 8'-6" above breaker foundation and live parts a minimum elevation above breaker foundation as listed below:

| | |
|----------|--------|
| 15.5 kV | 9'-0" |
| 25.0 kV | 10'-0" |
| 34.5 kV | 10'-0" |
| 46.0 kV | 10'-0" |
| 69.0 kV | 11'-0" |
| 115.0 kV | 12'-0" |
| 138.0 kV | 13'-0" |
| 161.0 kV | 14'-0" |

POWER CIRCUIT BREAKER**Section 33 7520 - Page 6 of 12****I. Breaker Monitoring**

1. Vacuum Breakers shall be provided with a means to determine contact wear.
2. Gas Breakers shall provide:
 - a. A temperature compensated gas pressure gauge pre-scaled in US units (pounds per square inch-PSI).
 - b. A two-stage temperature compensated gas monitoring system. The function of the second stage with regard to breaker operations is shown on the DATA SHEET. Contacts required for the Owner's use are:

| | Function | Contacts Required |
|----------|----------------------|-------------------|
| Stage #1 | Gas Pressure Alarm | (1) Form A |
| Stage #2 | Low Gas Trip/Lockout | (1) Form A |

A label/nameplate shall be affixed inside of cabinet indicating the alarm and trip/lockout gas pressures/settings.

- c. Piping that allows isolation of the interrupters to permit adjustment of low pressure alarm and lockout switches.
- d. The means to withdrawal gas for diagnostic testing or add gas without removing the breaker from service.
- e. All valves, fittings, gauges and other devices in the gas system shall be made of a non-rusting material.

2.3 OPERATING MECHANISM

- A. See the DATA SHEET for specific operating mechanism requirements.
- B. The operating mechanism shall conform to C37.04 and C37.11 **except** when different requirements are detailed in these specifications.
- C. The operating mechanism shall only require a ten (10) seconds to recharge the means of energy storage before completing an OCO (Open-Close-Open) operation.
- D. Spring-charged
 1. A circuit breaker utilizing a motor charged spring operator shall provide an OCO cycle without recharging of the spring mechanism. Spring charged stored energy mechanisms shall be normally charged by a universal motor with provisions for a manual handle for emergency closing or testing. Operating mechanism shall have the following:
 - a. Means to prevent overcharging of spring.
 - b. Means to prevent insufficiently charged spring from attempting to close breaker.
 - c. Mechanical indication that spring is charged, not fully charged or discharged.

POWER CIRCUIT BREAKER**Section 33 7520 - Page 7 of 12**

- d. Below is a simplified control diagram for the universal motor. Normal charging power shall be from the AC source with automatic transfer to the DC source upon loss of AC (contactor/relay contacts are shown with the coil de-energized):

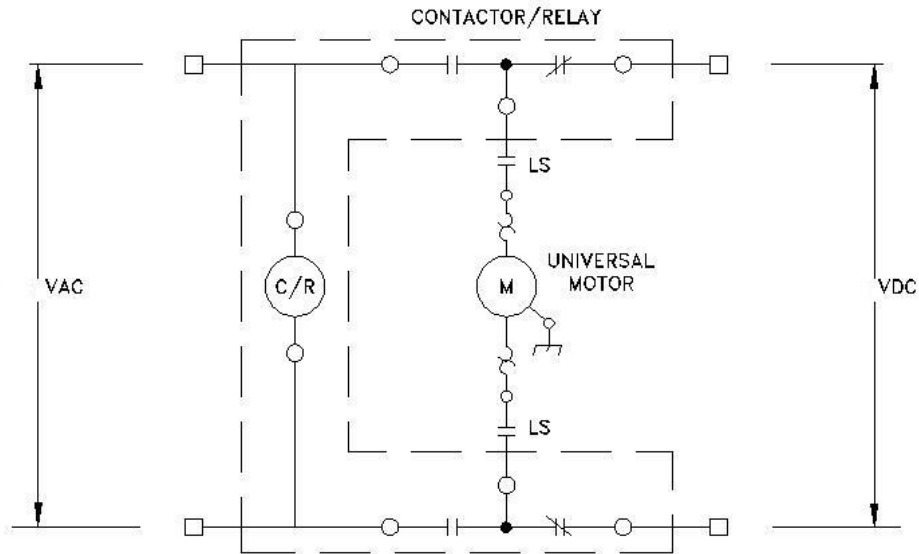
**E. Magnetic Actuator**

1. A circuit breaker utilizing a magnetic actuator shall use permanent magnets to hold the breaker contacts in place without control power (no energy consumption in either the open or closed and latched position).
2. Magnetically actuated breakers are required to have a manual release to Open the breaker, but is not required to have a manual release to Close. The circuit breaker shall be capable of interrupting its rated short-circuit current when manually Opened.

2.4 CONTROLS

- A. Controls shall be mounted on a hinged swing panel inside a weather-proof enclosure and be accessible from ground level.
- B. The Manufacturer shall provide all functional components listed in C37.04 including:
 1. Contact Position Indicator.
 2. Non-resetting operations counter which should increment during the opening operation.
 3. Power operated mechanism shall be trip-free and have an anti-pumping feature.
 4. Shunt release.
 5. Stored energy indicator.
 6. Manual Release.
- C. The circuit breaker shall be provided with push buttons or control switches for local operation. Owner's specific requirements are listed on the DATA SHEET.

POWER CIRCUIT BREAKER**Section 33 7520 - Page 8 of 12**

- D. When dual trip coils are specified on the DATA SHEET, the circuit breaker shall open within the specified parameters when either or both trip coils are energized.
- E. Isolated Form “C” alarm contacts shall be provided for the Owner’s use as indicated below:
 - 1. Manufacturer’s standard alarm points.
 - 2. Loss of Power to spring Charging Motor or Magnetic Actuator.
 - 3. Loss of DC Power Supply
- F. Control circuits shall contain provisions for Protective Relay Trip and Block Close interlocks from an external device.
- G. Control switch (see DATA SHEET).
- H. Remote/local control selector/transfer switch (see DATA SHEET)
- I. Position-Indicating Lamps (one red, one green) shall be mounted inside control cabinet. GE LED Type ET16.
- J. Minimum of 8 NO and 8 NC auxiliary switch contacts in addition to those required for operation for Owner’s use
- K. Wiring
 - 1. Terminal Blocks for connection of Owner’s cable shall be suitable for un-insulated ring terminals and No. 10 AWG conductor.
 - 2. All equipment control and power leads shall be prewired to terminal blocks for external connection. Terminal blocks shall be marked to identify leads.
 - 3. Wiring shall be clearly labeled, without splices or tee connections, and bundled as appropriate for usage.
 - 4. When separate Control and Operator Cabinets are required by manufacturers’ design, all cabling between cabinets shall be suitably protected by rigid or flex conduit with suitable fittings.
 - 5. All wiring shall have Pressure grip solderless lugs of the **uninsulated** ring-type terminators. Spade lugs will not be permitted.
 - 6. Suitable grommets and cable/conductor protection shall be used at locations of cable/conductor contact with edges, corners and openings of the control cabinet.
 - 7. No splices are allowed within the control, current transformer, or instrument wiring

POWER CIRCUIT BREAKER

Section 33 7520 - Page 9 of 12

leads. All connections shall utilize terminal blocks located in the control cabinet or junction boxes.

8. For easy access and permit an orderly arrangement of all leads terminating on each block. Wiring associated with one circuit, along with spare conductors shall be connected on adjacent terminals.
9. All alarm and trip contacts (not specified to be wired to an electronic transformer monitor) shall be wired to terminal blocks located in the main control cabinet, mounted on the main body of the transformer unit, for connection to external alarm and trip circuits.
10. For every ten (10) used terminals, two (2) spare terminals shall be provided.
11. All conductors shall be stranded copper (Class C or better) and insulated for 600 volts.
12. All secondary leads of the current transformers shall have a 150°C temperature rating and be #12 AWG, minimum.
13. All other control wiring shall have a 90°C temperature rating, pass the vertical flame test VW-1 and be #14 AWG, minimum.
14. All conductors shall be identified on each end with permanent labels.
15. A maximum of two (2) conductors on one (1) terminal point shall be permitted.
16. Terminal blocks shall be rated at 600 Vac minimum and be equipped with screw terminals. Terminal blocks shall be GE type EB-25 or Marathon 1500 Series. Step-type terminal blocks are not acceptable.
17. Terminal blocks within the control cabinet shall be mounted in a rectangular arrangement. The space between every other column of terminal blocks shall be reserved for Owner's connections as shown below:

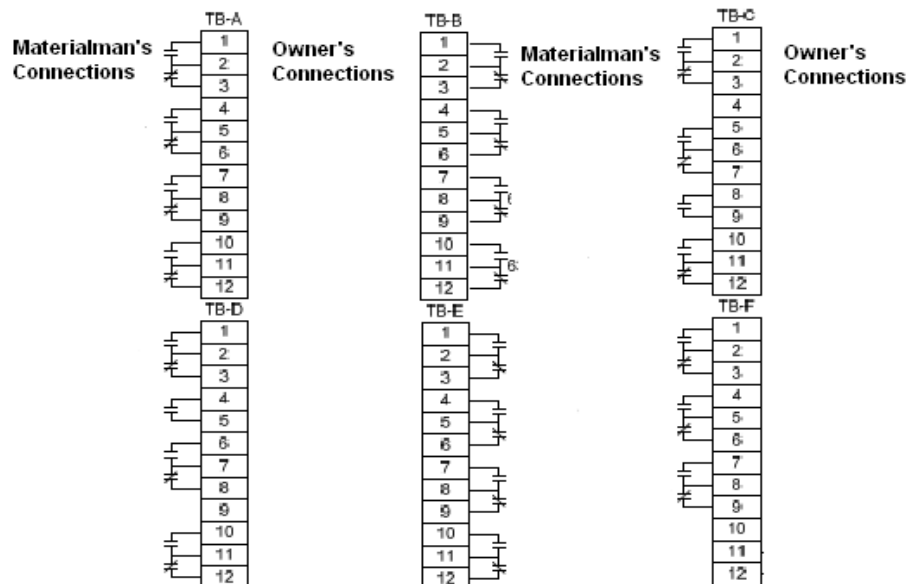

2.5 INSTRUMENT TRANSFORMERS

A. Current Transformers

1. All relay class bushing current transformers (BCT) shall be 5 lead, multi-ratio type with fully distributed windings with a minimum continuous current rating factor of 2.0. Ratio, Accuracy Class and location shall be as indicated on the DATA SHEET.
2. Revenue metering bushing current transformers, when specified on the DATA SHEET, shall be provided with the Ratio, Accuracy Class and location indicated and with the following additional requirements:
 - a. Four (4) copies of the Certified Test Report (CTR) shall be provided for each metering BCT supplied. Tests on prototypes or similar units are not acceptable.
 - b. The CTR shall include a ratio and phase-angle test on each ratio of each CT. Tests shall be made at 10 percent and 100 percent current for each burden and accuracy class specified.
 - c. Revenue metering current transformers shall have a minimum continuous current factor of 2.0.
3. Bushing Current Transformer Wiring:
 - a. All bushing current transformer leads shall be pre-wired to shorting type terminal blocks in the main control cabinet. From these terminal blocks, leads will be pre-wired to GE 6-pole PK-2 test blocks. The ratio and connection (wye or delta) will be formed at the shorting type terminal blocks. Therefore, for a three-phase transformer, one 6-pole PK-2 block will be required for each set of three-phase BCTs. A 4-pole PK-2 test block should be used for BCT circuit that is not a three-phase set.
 - b. Incoming BCT wiring to the PK-2 test blocks shall be terminated on the bottom of the block and the outgoing (relay/meter) wiring shall be terminated on the top of the block. For three-phase BCT sets, the H1 or X1 polarity lead shall be on left as viewed from the front of the panel.
 - c. Wiring from PK-2 blocks to terminal blocks for connection to external circuits shall be provided.
 - d. The shorting type terminal blocks shall be marked to identify CT ratio connections and shall be GE type EB-27 or Marathon Series 1500.
 - e. All secondary leads of the current transformers shall have a 150°C temperature rating and be #12 AWG, minimum.
 - f. An example showing the specified three-phase BCT circuit is shown below:

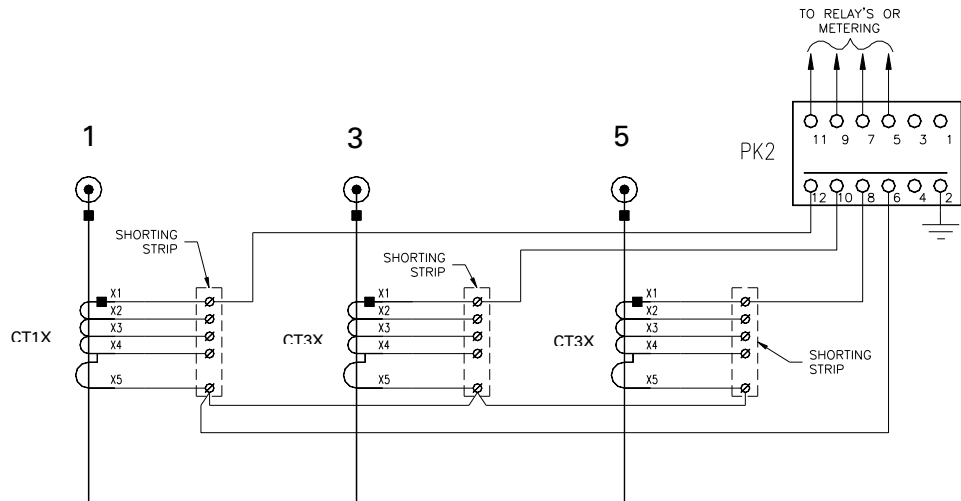

- g. Each CT shall have a unique alphanumeric designation on the breaker's nameplate.
- h. Labeling adjacent to the shorting type terminal blocks shall identify the CT using the breaker's nameplate designations.
- i. Phenolic nameplates adjacent to the PK-2 block shall identify the connected CT(s) using the breaker's nameplate designations.

2.6 ACCESSORIES

- A. Standard NEMA Accessories, as appropriate for the device.
- B. 120 VAC GFI Receptacle.
- C. Cabinet interior light (120 VAC), suitable for application and protected from accidental breakage, automatically controlled by cabinet door.
- D. Closing circuit shall contain a manually-reset closing circuit cut-out Switch (69) opened by breaker manual trip mechanism.
- E. One (1) travel recorder mounting device, if appropriate for the device.
- F. One (1) gauge for checking circuit breaker contact wear, if appropriate for the device.
- G. Field kit for installation of insulating gas, if appropriate for the device.
- H. Phenolic Nameplates, black with white core letters, shall be provided for all control and bypass switches and indicating lights and any major items of equipment mounted in the relay and control cabinets. Proposed engraving shall be submitted for approval.

2.7 PROTECTIVE RELAYING AND METERING

- A. Protective Relaying and Metering information is shown on DATA SHEET.

PART 3. EXECUTION

3.1 POWER CIRCUIT BREAKER TESTING

- A. Required Testing: Tests designated as routine in the latest revision of ANSI/IEEE C37.09.
- B. Certified copies of the test data shall be furnished and approved by the Engineer **before the breaker is shipped.**
 - 1. Test data shall include but not be limited to the following:
 - a. Data Sheets from all specified tests.
 - b. Data Sheets for all other routine tests complete by the Materialman, but not specified by the Engineer.

END OF SECTION

POWER CIRCUIT BREAKER DATA SHEET

Section 33 7520D - Page 1 of 5

69 kV HIGH VOLTAGE 1200A CIRCUIT BREAKER
PERFORMANCE REQUIREMENT DATA SHEET

| | | |
|-----|--|--|
| 1. | Type of breaker | Dead Tank |
| 2. | Insulating medium | SF ₆ gas (request alt. vacuum bid if available) |
| 3. | Nominal voltage rating | 69 kV |
| 4. | Maximum voltage rating | 72.5 kV |
| 5. | Frequency and phase | 60 Hz, 3 phase |
| 6. | Continuous Current (47° C) | 1200A |
| 7. | Rated short circuit current | 40 kA sym rms at 72.5 kV |
| 8. | Ambient Temperature Range | -25°C to 40°C |
| 9. | Short time capacity (3 sec) | 40 kA |
| 10. | Control operating voltage | 125VDC or 120Vac |
| 11. | Rated chopped wave impulse voltage 2μ-sec (kV) | 452 kV |
| 12. | Rated lightning impulse withstand voltage (kV) | 350 kV |
| 13. | Power frequency withstand (dry) | 140 kV |
| 14. | Rated Interrupting time | 3 cycles |
| 15. | Duty cycle | O-CO-15s-CO |
| 16. | NESC Vertical Clearance unguarded parts | 11 ft – 0 in (Min)* |
| 17. | Seismic Zone | Moderate |
| 18. | Minimum Creepage Distance | 1.38 in – (35mm) |
| 19. | Heater Type | Positive Temperature Coefficient (PTC) |
| 20. | Control switch | 125Vdc |
| 21. | Bushing current transformer (BCT) | 2 sets – 1200:5 C800 |
| | | |
| | | |
| | | |
| | | |
| | | |

Notes:

(*) – Per Table 124-1 NESC

(**) – Per latest ANSI/IEEE Standards

POWER CIRCUIT BREAKER DATA SHEET

Section 33 7520D - Page 2 of 5

CONTRACTOR'S BREAKER PERFORMANCE DATA SHEET*(Contractor to complete all data for Circuit Breaker proposed)***GENERAL TECHNICAL DATA**

| | | | |
|--|-------------|--|--|
| Rated nominal voltage | (kV, rms) | | |
| Rated maximum voltage | (kV, rms) | | |
| Rated voltage range factor, K | | | |
| Rated frequency | Hz | | |
| Rated continuous current (47° C) | (A, rms) | | |
| Rated short-circuit current at rated maximum voltage | (kA, rms) | | |
| Rated short-circuit current (3 second) | (kA, rms) | | |
| Rated short line fault interrupting capability | | | |
| Rated out of phase switching current | (kA, rms) | | |
| Rated capacitance switching current | (amps, rms) | | |
| Rated standard operating duty cycle | | | |
| Rated interrupting time | (cycles) | | |
| Closing and Latching capacity | (kA, peak) | | |
| Closing time (main contacts make) | (ms) | | |
| Minimum reclosing time | (ms) | | |
| Permissible tripping delay | (sec) | | |
| Arc extinction time, max/min | (ms) | | |
| Opening time from energization of trip coil to contact parting | | | |
| 1. At rated voltage | (ms) | | |
| 2. At minimum voltage | (ms) | | |
| Main contact material | | | |
| Number of interrupters per phase | | | |
| Maximum impact noise level, during operation, at a point 3 feet from the breaker | (dBA) | | |

WITHSTAND VOLTAGES

| | | | |
|--|------------|--|--|
| Power frequency withstand (dry) | (kV, rms) | | |
| Full wave impulse (1.2 x 50 μ sec.) between terminals & to earth | (kV, peak) | | |

POWER CIRCUIT BREAKER DATA SHEET

Section 33 7520D - Page 3 of 5

OPERATING MECHANISM

| | | | |
|--|--|--------|--|
| Type – Pneumatic or Spring (closing/opening) | | | |
| Operating Voltage | | (VDC) | |
| Closing Current at 125 VDC | | (amps) | |
| Trip Current at 125 VDC | | (amps) | |
| Closing voltage range | | (V) | |
| Tripping voltage range | | (V) | |
| Number of trip coils | | | |

AIR SUPPLY SYSTEM (WHERE APPLICABLE)

| | | | |
|--|--|-------------|--|
| Compressor Motor Voltage | | (V) | |
| Compressor Motor Output | | (hp) | |
| ASME safety valve certifications | | (Yes or No) | |
| Capacity of Air Reservoir | | | |
| Maximum Design Pressure | | | |
| Operating Duty | | (ANSI) | |
| Number of CO Operations without recharging | | | |
| Safety Valve Working Pressure | | | |

MINIMUM NUMBER OF OPERATIONS BEFORE THE BREAKER MUST BE REMOVED FROM SERVICE FOR MAINTENANCE OR INSPECTION

| | | | |
|---|--|--|--|
| No load mechanical operations | | | |
| Full load non-fault operations | | | |
| Rates short-circuit current breaking operations | | | |
| Expected number of man-hours required to perform a complete maintenance inspection of one breaker (including gas handling time) | | | |
| Number of breaker operations without motor operations | | | |

POWER CIRCUIT BREAKER DATA SHEET

Section 33 7520D - Page 4 of 5

CURRENT TRANSFORMERS

| | | | | |
|--------------------------------------|--|--|--|--|
| Poles 1, 3 and 5: | | | | |
| 1. Number of CT's per pole | | | | |
| 2. Rated primary / secondary current | | | | |
| 3. Accuracy class | | | | |
| Poles 2, 4 and 6: | | | | |
| 1. Number of CT's per pole | | | | |
| 2. Rated primary / secondary current | | | | |
| 3. Accuracy class | | | | |
| Number of CT's per Circuit Breaker | | | | |

AUXILIARY POWER REQUIREMENTS

| | | | | |
|---|--|------|--|--|
| Spring Charge Motor Horsepower | | (hp) | | |
| Full Load current at 125 VDC | | | | |
| Locked Rotor current at 125 VDC | | | | |
| Total connected 1-phase load at 120 VAC | | (kW) | | |

BUSHINGS

| | | | | |
|--|--|-----------|--|--|
| Manufacturer / part number | | | | |
| Material | | | | |
| Dry-1 min 60 Hz withstand (per ANSI) | | (kV, rms) | | |
| Wet-10 sec 60 Hz withstand (per ANSI) | | (kV, rms) | | |
| Phase-to-ground external strike distance | | (in) | | |
| Phase-to-phase external strike distance | | (in) | | |
| External creep distance | | (in) | | |
| Cantilever strength | | (ft-lbs) | | |
| Acceptable terminal load | | (lbs) | | |
| Rated current | | (A) | | |
| Color | | | | |

POWER CIRCUIT BREAKER DATA SHEET

Section 33 7520D - Page 5 of 5

GAS SYSTEM

| | | | | |
|---|--|--------|--|--|
| Rated SF6 pressure at 20°C | | (psig) | | |
| SF6 alarm pressure at 20°C | | (psig) | | |
| SF6 lockout pressure at 20°C | | (psig) | | |
| Type of pressure relief device | | | | |
| Setting of pressure relief device | | (psig) | | |
| Total required SF6 gas supplied for Circuit Breaker | | (lbs) | | |

WEIGHTS, DIMENSIONS AND CLEARANCES

| | | | | |
|---|--|-------|--|--|
| Total weight (with SF6 gas) | | (lbs) | | |
| SF6 gas weight | | (lbs) | | |
| Bushing (1P) | | (lbs) | | |
| Total shipping weight of Circuit Breaker | | (lbs) | | |
| Overall height of Circuit Breaker | | (in) | | |
| Overall length of Circuit Breaker | | (in) | | |
| Overall width of Circuit Breaker | | (in) | | |
| Phase spacing between Circuit Breaker poles | | (in) | | |
| Clearance required above Circuit Breaker | | (in) | | |
| Clearance to ground | | (in) | | |

END OF SECTION

IRAN DIVESTMENT ACT NOTICE

Tenn. Code Ann. § 12-12-106 requires the chief procurement officer to publish, using credible information freely available to the public, a list of persons it determines engage in investment activities in Iran, as described in § 12-12-105.

For these purposes, the State intends to use the attached list of “Entities determined to be non-responsive bidders/offers pursuant to the New York State Iran Divestment Act of 2012.”

While inclusion on this list would make a person ineligible to contract with the state of Tennessee, if a person ceases its engagement in investment activities in Iran, it may be removed from the list.

If you feel as though you have been erroneously included on this list please contact the Central Procurement Office at CPO.Website@tn.gov.

List Date: May 4, 2022

Source: <https://www.ogs.ny.gov/iran-divestment-act-2012>

1. Ak Makina, Ltd.
2. Amona
3. Bank Markazi Iran
(Central Bank of Iran)
4. Bank Mellat
5. Bank Melli Iran
6. Bank Saderat Iran
7. Bank Sepah
8. Bank Tejarat
9. China Precision Machinery
Import- Export Corporation
(CPMIEC)
10. ChinaOil (China National United
Oil Corporation)
11. China National Offshore Oil
Corporation (CNOOC)
12. China National Petroleum
Corporation (CNPC)
13. Indian Oil Corporation
14. Kingdream PLC
15. Naftiran Intertrade Co. (NICO)
16. National Iranian Tanker Co.
(NITC)
17. Oil and Natural Gas Corporation
(ONGC)
18. Oil India, Ltd.
19. Persia International Bank
20. Petroleos de Venezuela
(PDVSA Petróleo, SA)
21. PetroChina Co., Ltd.
22. Petronet LNG, Ltd.
23. Sameh Afzar Tajak Co. (SATCO)
24. Shandong FIN CNC Machine
Co., Ltd.
25. Sinohydro Co., Ltd.
26. Sinopec Corp. (China
Petroleum & Chemical
Corporation)
27. SKS Ventures
28. SK Energy Co., Ltd.
29. Som Petrol AS
30. Unipet (China International
United Petroleum & Chemicals
Co., Ltd.)
31. Zhuhai Zhenrong Co.

IRAN DIVESTMENT ACT

“By the submission of this bid, each bidder and each person signing on behalf of any bidder certifies, and in the case of a joint bid each thereto certifies as to its own organization, under penalty of perjury, that to the best of its knowledge and belief that each bidder is not a person included within the list created pursuant to § 12-12-106.”

Signature: _____

Date: _____

Title: _____