



Platte County R-3 School District

Wilson Auditorium AV Upgrades – Phase 2

Request for Proposal (RFP)

January 2, 2020

THIS PAGE LEFT BLANK INTENTIONALLY

Table of Contents

Table of Contents	3
Notice to Bidders	4
Instructions to Bidders	5 - 6
Prevailing Wage Determination 008100	2 pages
EXHIBIT A – PROPOSAL FORM	3 pages
EXHIBIT B – E-VERIFY FORM	1 page
EXHIBIT C - STATEMENT OF BIDDERS QUALIFICATIONS	2 pages
EXHIBIT D – AV PLANS	5 pages
EXHIBIT E – AV STANDARDS	4 pages
EXHIBIT E –SPECIFICATIONS	157 pages
APPENDIX A – PROJECT PHASES	3 pages

Notice to Bidders

The Platte County R-3 School District wishes to obtain bids for the second phase of AV upgrades for Wilson Auditorium.

The Platte County R-3 School District will receive sealed proposals from Bidders **until Thursday, February 6, 2019, at 2 p.m.**, at which time, the bids received will be opened. The Platte County R-3 School District reserves the right to reject any or all bids and to waive informalities or irregularities in bids.

Each sealed bid shall contain Bid Proposal, e-Verify and Bidders Qualification; forms for each are attached to this RFP.

Bids shall be in sealed envelopes labeled:

**Platte County R-3 School District
Wilson Auditorium AV Upgrades – Phase 2
Mr. Jay Harris
Executive Director of Operations
Platte County R-3 School District
998 Platte Falls Road
Platte City, MO 64079**

Bids received after the time and date above specified shall be returned, unopened, to the Bidder.

Any questions related to this RFP or bid requirements, please contact:

Mr. Jay Harris
816.858.5420
harrisj@platteco.k12.mo.us

Instructions to Bidders

PROPOSALS: All proposals must be made on the forms provided herein. All proposals must be legibly written. No alterations in proposals or in the printed forms will be acceptable unless each alteration is signed by the Bidder. No alterations or physical changes shall be made by anyone, in any bid, after its submission by the Bidder.

SIGNATURE OF BIDDERS: Each Bidder shall sign a proposal, using the customary name under which the Bidder does business, utilizing the customary signatures of an authorized representative, and providing a full business address, including identity of any registered or local agent.

WITHDRAWAL OF BID: A Bidder may withdraw its proposal at any time prior to the expiration of the time and date during which proposals may be submitted, by written request submitted by the Bidder to the Platte County R-3 School District. A Bidder may correct any mistakes in its bid by submitting a written request to the Platte County R-3 School District, provided the written request is made and the bid is corrected and resubmitted prior to the expiration of the time and date during which proposals may be submitted.

BID PROPOSAL INSTRUCTIONS: A Bidder shall submit a completed Bid Proposal Form. Each project is identified on the Bid Proposal Form.

INSURANCE: Contractor shall provide certificates of insurance and renewals thereof on standard ACORD forms. This inclusion shall not make the Platte County R-3 School District a partner or joint venture with the Contractor in its operations hereunder. The School District shall be notified by receipt of written notice from the insurer at least thirty (30) days prior to material modification or cancellation of any policy listed in the certificate.

Contractor will provide the School District with proof of liability insurance in the minimum amount of \$1,000,000.00 listing Platte County R-3 Schools as additionally insured.

Contractors will also provide proof of Worker's Compensation insurance in the minimum amount of \$500,000.00 listing Platte County R-3 Schools as additionally insured.

EXCEPTIONS: The bidder shall furnish a statement on company letterhead giving a complete description of any exception to the terms, conditions, and specifications. Failure to furnish the statement will mean that the bidder agrees to meet all requirements of the Request for Proposal.

RESPONSIBILITY OF CONTRACTOR: The Contractor shall furnish all labor, transportation, tools, equipment, machinery, and all suitable appliances, requisite for execution of this agreement and shall be solely answerable for the same and for the safe, proper, and lawful construction, maintenance, and use thereof. Contractor shall be solely answerable for all damage to any Platte County R-3 School District property, to other contractors or other employees of the School District, to the neighboring premises, or to

any private or personal property, due to improper, illegal, or negligent conduct of itself or its subcontractors, employees, or agents in and about said work, or in the execution of the work covered by this agreement, or any extra work undertaken as herein provided.

Contractor shall not assign this agreement. The agreement will be terminated in the event the contractor sells the business. The School District reserves the right to continue with the new owner or select another contractor.

RELATIONS WITH OTHER CONTRACTORS: The Contractor shall cooperate with all other contractors who may be performing work on behalf of the School District, and workers who may be employed by the School District, on any work in the vicinity of the work to be done under this agreement, and the Contractor shall so conduct its operations as to interfere to the least possible extent with the work of such contractors or workers.

PROTECTION OF PUBLIC AND PRIVATE PROPERTY: The Contractor shall assume full responsibility for the protection of all public and private property, structures, sewers, and utilities, both above and below ground, along, beneath, above, across or near the site or sites of the work being performed under this agreement, or which are in any manner affected by the prosecution of the work or the transportation of men or materials in connection therewith.

COMPLIANCE WITH O.S.H.A. REGULATIONS: The Contractor shall comply with all regulations of the Occupational Safety and Health Administration (OSHA) and hold the School District and its representatives harmless from all actions resulting from the Contractor's failure to comply with said regulations, orders and citations.

VERBAL STATEMENTS NOT BINDING: It is understood and agreed that the written terms and provisions of this agreement shall supersede all prior verbal statements of any and every official and/or other representative of the School District, and such statements shall not be effective or be construed as entering into, or forming a part of, or altering in any way whatsoever, the written agreement.

PAYMENTS: Payment shall be made to the Contractor upon completion of the work.

COMPLETION: The Platte County R-3 School District wishes to have this AV work done by Friday, August 7, 2020. Refer to specification section 01200 for additional information.

TERMINATION: Platte County R-3 School District reserves the right to terminate the agreement without notice for just cause which may include but not limited to some of the following: unauthorized staff of the contractor (sex offenders, convicted felons, etc.); weapons on school property; inappropriate behavior with students or staff; use of alcohol, tobacco or drugs on school property; use of unauthorized sub-contractors or 1099 employees; use of illegal alien employees; lapse of insurance coverage; failure to complete work as specified; poor quality of work; damage to school district property; etc.

SECTION 008100

PREVAILING WAGE DETERMINATION

PART 1 - GENERAL

- 1.1 This Project is contracted under the requirements of Missouri Prevailing Wage Law. This Section includes general information and forms for convenience. Detailed requirements, information, forms, and assistance may be obtained by contacting the following:
1. Missouri Department of Labor and Industrial Relations
Division of Labor Standards
Prevailing Wage Section
PO Box 449
Jefferson City, MO 65102-0449
Phone: 573-751-3403
Fax: 573-751-3721
Email: prevailingwage@labor.mo.gov
Website: www.labor.mo.gov/lis/prevailingwage
- B. Prevailing Hourly Rate of Wages: Not less than the prevailing hourly rate of wages, as set out in the wage order attached, must be paid to all workers performing work under this Contract.
1. Contractor shall forfeit a penalty to the contracting public body of \$100 per day (or portion of a day) for each worker that is paid less than the prevailing rate for any work done under this Contract by the Contractor or by any Subcontractor.
 2. Submit certified copies of Contractor's and subcontractor's payrolls to contracting public body on a weekly basis.
- C. Safety Training Program: All on-site employees, including those of Contractor and subcontractors, are required to complete the ten-hour safety training program required under Section 292.675 RSMo, if they have not previously completed the program and have documentation of having done so.
1. Contractor shall forfeit a penalty to the contracting public body of \$2500 plus an additional \$100 for each employee, including those of subcontractors, for each calendar day, or portion thereof, such employee is employed without the required training.
- D. Construction Transient Employers: Every transient employer, as defined in section 285.230 RSMo, must post in a prominent and easily accessible place at the site, a clearly legible copy of the notices listed below. Any transient employer failing to comply with these requirements shall, under section 285.234 RSMo, be liable for a penalty of \$500 per day until notices are posted as required by the statute:
1. The notice of registration for employer withholding issued to such transient employer by the director of revenue.
 2. Proof of coverage for workers' compensation insurance or self-insurance signed by transient employer and verified by the Department of Revenue through records of the Division of Workers' Compensation.
 3. The notice of registration for unemployment insurance to such transient employer by the Division of Employment Security.
- E. Posting of Wage Rates: While work under this Contract is being performed, a legible list of all prevailing wage rates must remain posted in a prominent and easily accessible location at the site by the Contractor and each subcontractor on the project. Such notice shall remain posted during the full time that any worker is employed on the project.
- F. Project Notification - Contractor Information Notification: Before performing any Work, submit a completed PW-2 Form "Prevailing Wage Project Notification - Contractor Information Notification,"

available at www.labor.mo.gov/ls/prevailingwage under "Forms," to The Division of Labor Standards (DLS).

- G. Project Completion Notification – Affidavit of Compliance: Before final payment will be made, the Contractor shall file a fully executed affidavit, PW-4 Form "Affidavit – Compliance with the Prevailing Wage Law", available at www.labor.mo.gov/ls/prevailingwage under "Forms," to The Division of Labor Standards (DLS).
- H. Monthly Applications for Payment: Pursuant to prevailing wage laws, an Affidavit of Compliance (Form PW-4) must be filed with the District before payment will be approved. The District will withhold and retain any amounts due as a result of any violation of the prevailing wage law prior to making payment with any contractor. Include Affidavit of Compliance with each application for payment.

PART 2 - PRODUCTS (NOT APPLICABLE)

PART 3 - EXECUTION (NOT APPLICABLE)

END OF SECTION 008100

PROPOSAL FORM – EXHIBIT ‘A’

Bid to:

Platte County R-3 School District
Attn: Mr. Jay Harris
998 Platte Falls Rd
Platte City, MO 64079

Place of Bid Opening:

Platte County R-3 School District
998 Platte Falls Rd
Platte County, MO 64079

Bid for:

Wilson Auditorium AV Upgrades – Phase 2
Platte City, MO 64079

Date and Time for Receipt of Bids:

Thursday, February 6, 2020 at 2:00 p.m. (Local Time)

We, the undersigned Bidder, hereby submit our Proposal on the General Contract for the **Platte County R-3 School District – Wilson Auditorium AV Upgrades – Phase 2**, which includes; all electrical work listed below.

Name of Bidder: _____

Address of Bidder: _____

Telephone Number: _____ Fax Number: _____

1. THE SITE AND THE DOCUMENTS

We have carefully examined the site and all conditions affecting the work.

We have carefully examined the following documents:

We the undersigned, having examined the Contract Documents listed below and the site of the proposed Work and being familiar with all conditions affecting the construction of the Project, here by propose and agree to provide and furnish all labor, material, equipment, supervision and other items necessary to perform and complete, in a workmanlike manner, all Work required by the contract Documents, at the prices stated below. Stated sums include fees, insurance, payroll taxes, and all other charges applicable to materials, appliances, labor and all charges that may be levied. This Bid excludes sales tax.

- (a) Prevailing Wage Determination
- (b) E-Verify
- (c) Technical Specifications
- (d) Drawings

In the following proposal, the amounts shall be shown in both words and figures. In case of discrepancy between the word and the figures, the words shall govern. Owner intends to award the Contract to a single Bidder.

2. THE AMOUNT OF THE BASE BID

We propose to furnish all materials and labor for the **Wilson Auditorium Upgrades – Phase 2** called for by the above Documents for the Base Bid work for the total sum of:

_____ Dollars and Cents
(\$ _____).

3. CHANGES IN THE WORK

Changes in the Work shall be as established in the Contract Documents. The following fees shall be used for Lump Sum pricing and actual cost pricing of additions and deletions to that work included in the Bid, namely:

	<u>Overhead & Profit</u> <u>Not to Exceed</u>
A. To Contractor for work performed by his/her own forces.	10%
B. To Contractor for work performed by other than his/her own forces.	5%
C. To Subcontractor for work performed by his/her own forces.	10%
D. To Subcontractor for work performed by other than his/her own forces.	5%

4. COMPLETION OF THE WORK

If we are notified of the acceptance of the Base Bid of this Proposal within thirty (30) days after the above date, we agree to execute a Contract for the above Work, for the above stated compensation and agree to guarantee the Substantial Completion and completion of all punch list work as listed hereinafter:

Substantial Completion Date: 8/7/2020

The Undersigned hereby agrees to commence work under the Contract within seven (7) days after the date of a "Notice to Proceed", unless otherwise stipulated in that notice.

5. PERFORMANCE BOND AND PAYMENT BOND

We, the undersigned, agree to furnish to the Owner a Performance Bond and Payment Bond in the amount of 100 percent of the Contract Sum. Form of the Bond shall be AIA Document A312 from the American Institute of Architects, as modified by Owner.

6. ACKNOWLEDGEMENT AND SEAL

We, the undersigned, acknowledge and agree that the Owner reserves the right to waive any informalities in any Bid and to reject any or all Bids.

The undersigned Bidder, on behalf of itself and all sub-bidders, releases the Owner, Architect, and other Bidders from any claim arising out of or relating to the acceptance, non-acceptance, or rejection of the undersigned's or any other Bidder's Bid, including without limitation, Bids of it's sub-bidders on this Project.

NOTE: If the Contractor is a Corporation, Proposal must be signed by an authorized officer, showing his/her title.

Corporate Seal (Below)

Yours very truly,

FIRM

ADDRESS
TELEPHONE: _____
FAX: _____
BY: _____
TITLE: _____
STATE OF INCORPORATION: _____
FIN _____ or SSN _____

Notary Seal (Below)

Notary Public
Subscribed and sworn to before me within and for
STATE OF _____
COUNTY OF _____
On this _____ Day of _____, 20____
My Commission Expires: _____

END OF PROPOSAL FORM

STATE OF MISSOURI

COUNTY OF __PLATTE

AFFIDAVIT

Before me, the undersigned authority, personally appeared _____
_____, who, being by me duly sworn, deposed as follows:

My name is _____, I am of sound mind, capable of making this
affidavit, and personally acquainted with the facts herein stated:

1. I am an officer/agent of _____ (company name) _____ and
have the authority to make these affirmations.

2. _____ (company name) _____ has enrolled and participates in a federal work
authorization program with respect to the employees working in connection with _____
_____ (company name's) _____ contract with the Platte County School District. Such
participation is confirmed by the following documentation attached hereto: _____ (list
documentation provided by company) _____.

3. _____ (company name) _____ does not knowingly employ any person who is an
unauthorized alien in connection with the contracted services for the _____ School
District.

Affiant

In witness whereof I have hereunto subscribed by name and affixed my official seal this
_____ day of _____, 20_____.

(Seal)

Notary Public

My Commission Expires:

EXHIBIT 'C'

STATEMENT OF BIDDER'S QUALIFICATIONS

Each bidder for the work included in the specifications and bid documents shall submit with their bid the data requested in the following information. This data must be included in and made a part of each bid document and be contained in the sealed envelope. Failure to comply with this instruction may be regarded as justification for rejecting the contractor's bid.

Name of Bidder: _____

Business Address: _____

When Organized: _____

Date Incorporated: _____

Number of years engaged in conducting business under present firm name: _____

If you have operated business under a different name, please give name and location.

Have you ever failed to complete any work awarded to your company? If so, where and why?

Have you ever defaulted on a contract? If so, where and why?

**PLATTE COUNTY HIGH SCHOOL
 WILSON AUDITORIUM AV UPGRADES - PHASE 2**
 1501 BRANCH STREET
 PLATTE CITY, MO 64079

THIS DOCUMENT IS RELEASED FOR THE PURPOSE OF PRELIMINARY SUBMITTAL.
 LICENSE #
 IT IS NOT TO BE USED FOR CONSTRUCTION PURPOSES.

PROFESSIONAL SEAL
 REVISIONS

JOB NO: 1950001098
 DATE: 01/02/2020
 CHECKED BY:
 DRAWN BY:

TA701
 SIGNAL FLOW DIAGRAM

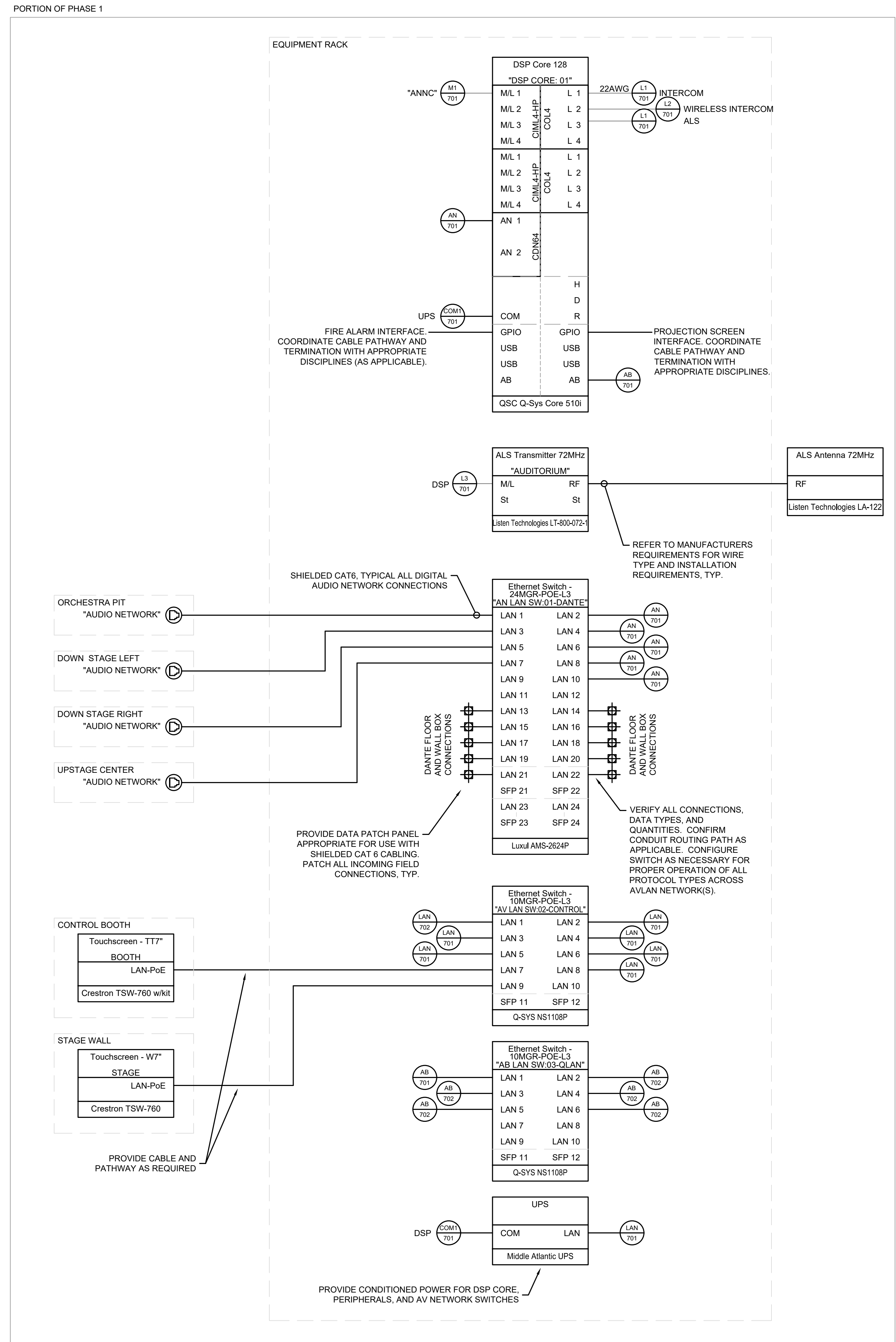
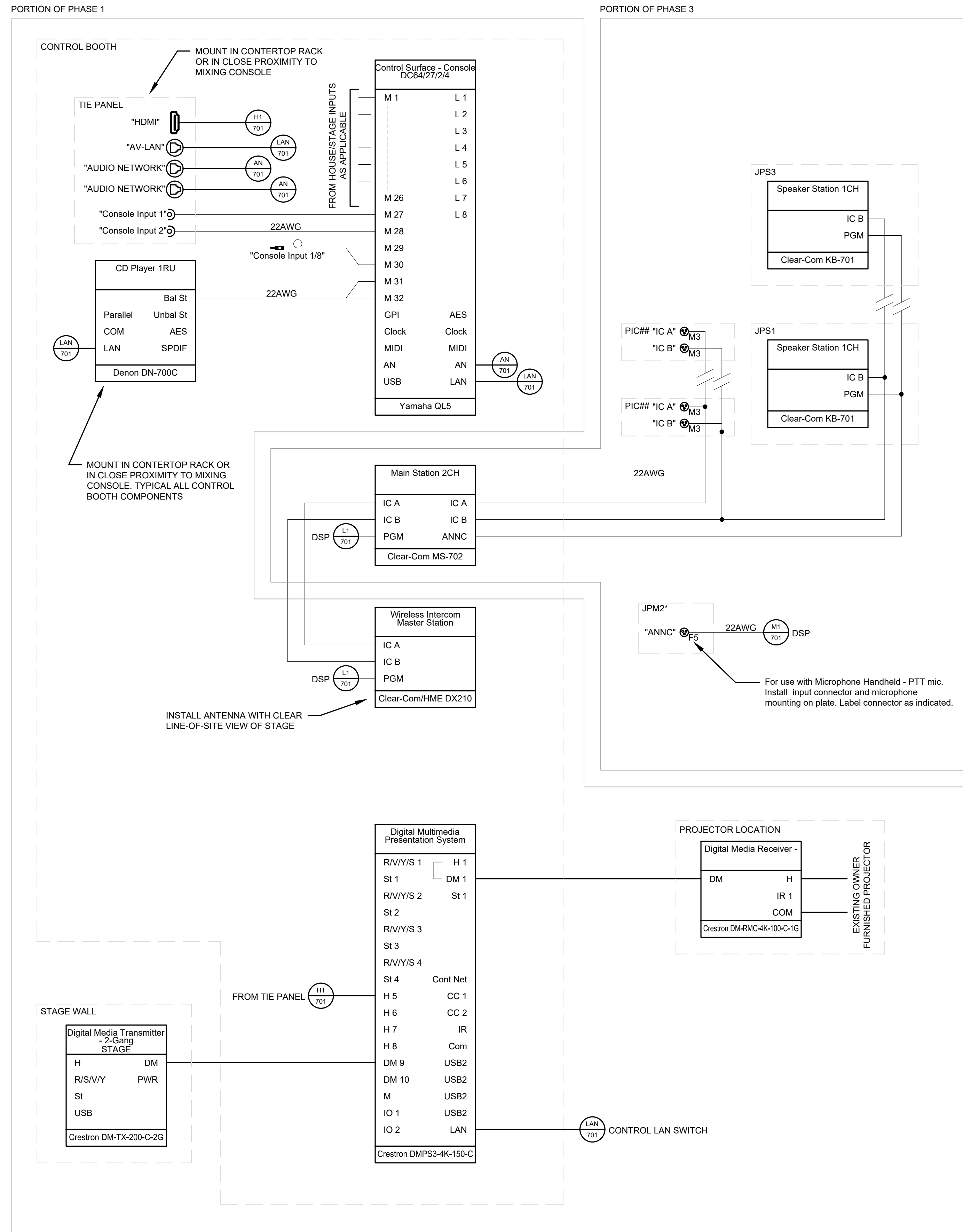

**PLATTE COUNTY HIGH SCHOOL
 WILSON AUDITORIUM AV UPGRADES - PHASE 2**
 1501 BRANCH STREET
 PLATTE CITY, MO 64079

THIS DOCUMENT IS RELEASED FOR THE PURPOSE OF PRELIMINARY SUBMITTAL.
 LICENSE #
 IT IS NOT TO BE USED FOR CONSTRUCTION PURPOSES.

PROFESSIONAL SEAL
 REVISIONS

JOB NO: 1950001098
 DATE: 01/02/2020
 CHECKED BY:
 DRAWN BY:

TA702
 SIGNAL FLOW DIAGRAM

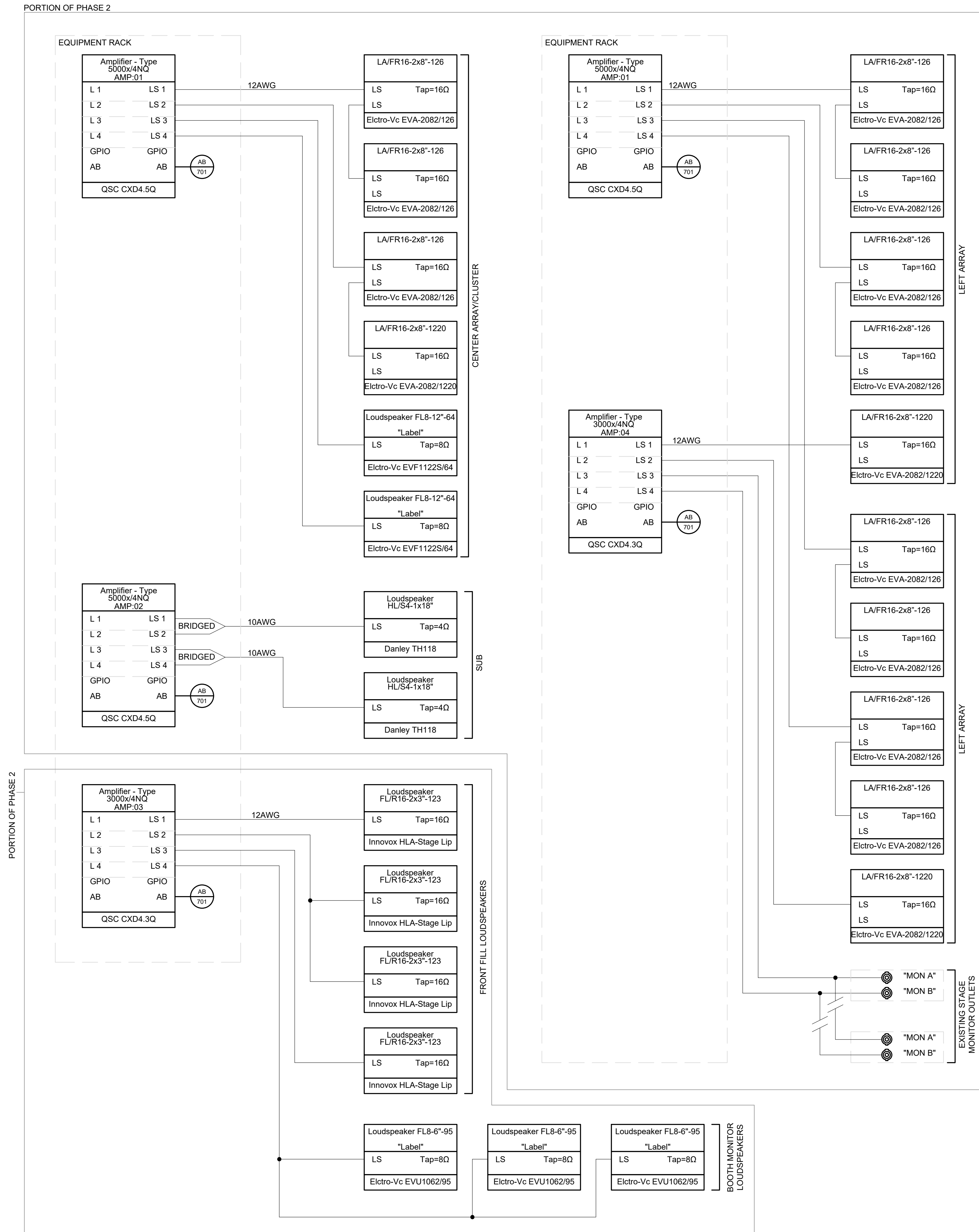

① SIGNAL FLOW - AUDITORIUM LOUDSPEAKER SYSTEM
 NTS

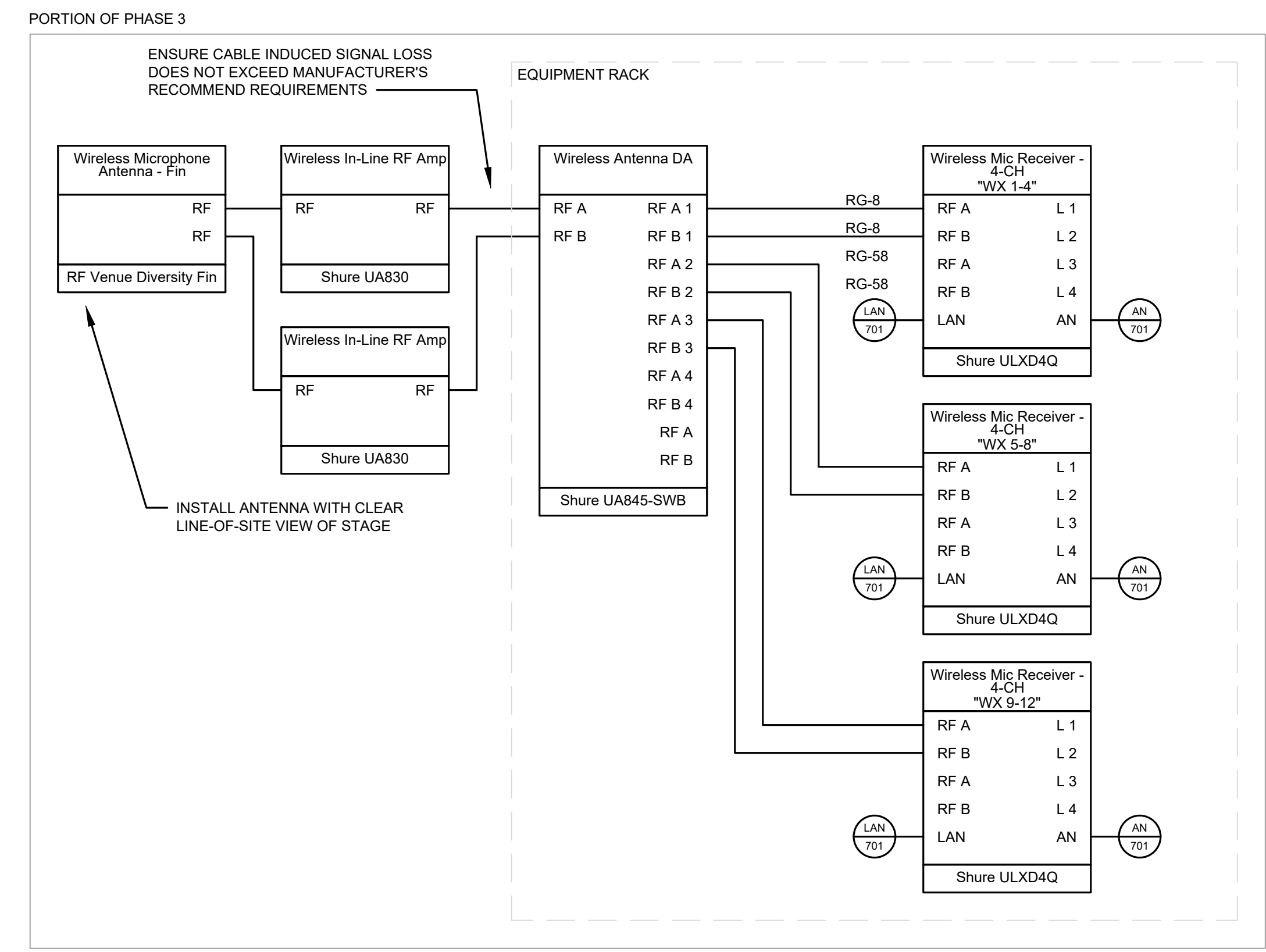

② SIGNAL FLOW - WIRELESS MICROPHONE SYSTEM
 NTS

ENSURE CABLE INDUCED SIGNAL LOSS DOES NOT EXCEED MANUFACTURER'S RECOMMEND REQUIREMENTS

INSTALL ANTENNA WITH CLEAR LINE-OF-SITE VIEW OF STAGE

PLATTE CITY R-3 SCHOOL DISTRICT

HIGH SCHOOL PERFORMING ARTS AUDIO-VIDEO SYSTEMS
MINIMUM CAPABILITIES AND RECOMMENDED SOLUTIONS

This document sets forth minimum audio-video system standards for the Platte City R-3 Wilson Center for the Performing Arts. Please provide a complete proposal (defined per project phase) for new equipment, materials and labor as necessary to fulfill the standards set forth in this document. See conceptual signal flows and Appendix A Project Phases document.

Final equipment selection and configuration of system upgrades or enhancement will be subject to review by the District's appointed Consultant by way of a traditional construction project submittal process.

Coordinate Owner's general contractor to ensure proper pathways and structural mounting points.

1. VIDEO TRANSPORT AND ROUTING

- A. Video signal transport and routing shall be provided by a combined Control System Processor/Video Router system.
 - 1. Crestron DMPS3-4K-150-C control unit shall be installed within the existing control booth rack located next to the sound mixing console
 - 2. Video inputs:
 - a) Stage: Provide Crestron DM-TX-200C-2G-B-T installed at stage left or right proscenium opening (coordinate with touch screen controller location)
 - b) Booth: Provide hard-wired HDMI connection from the Control System Processor/Video Router to the Owner provided PC located near the sound mixing console.

2. SYSTEM CONTROL

- A. System Control shall be provided by way of touchscreens and related accessories connected to the Control System Processor/Video Router.
 - 1. Crestron TSW-760 touch screen controllers: (1) for installation in control booth (with tabletop kit), and (1) for installation on stage wall.
 - 2. Control parameters shall include:
 - a) Audio-Video System on/off
 - b) Basic Mode parameters:
 - (1) Projector Power
 - (2) Projector Source Selection
 - (3) Screen Up/Down Control
 - (4) Volume Control of Wireless Microphones 1 & 2
 - (5) Volume Control of Wall Mount Media Input
 - (6) Volume Control of Projector Media
 - c) Advanced Mode parameters:
 - (1) Screen Up/Down Control
 - (2) Projector Power
 - (3) Projector Source Selection
 - 3. Control System Network Switch
 - a) Provide managed network switch conforming to District IT systems. Ensure available ports for the following devices:
 - (1) Control System Processor/Video Router
 - (2) Touch Screen Controllers: Stage and Booth

3. DIGITAL AUDIO TRANSPORT

Using standard Ethernet technology, the digital audio network allows the transfer of large numbers of audio channels among multiple locations, over long distances, and with low latency. Used in conjunction with traditional audio cabling it provides flexible routing including the potential to add portable multi-input connection boxes using a single category cable.

A. Wiring infrastructure:

1. CAT6 shielded
2. Stage and orchestra pit locations connectors: Neutrik Ethercon

B. QLAN digital audio network by QSC.

1. Network switch requirements:
 - a) Gigabit rated (1000 Mbps)
 - b) Non-blocking
 - c) Quality of Service (QoS) with Diffserv (DSCP)
 - d) Egress Queues – minimum four egress queues per port
 - e) Egress Buffering - 40 kB egress buffering memory per A/V port
 - f) Strict Priority Queueing -
 - g) The ability to disable EEE (also called Green Ethernet)
 - h) Additional information is available at:
https://www.qsc.com/resource-files/productresources/dn/3rd_party_control/q_tn_sys_dn_qsys_generalswitchrequirements.pdf

C. Recommended pre-configured switches:

- a) QSYS NS Series switches

D. Required QLAN Drop Locations and minimum quantity:

1. Digital Signal Processor
2. Each QLAN compatible amplifier
3. Each control touch screen
1. Network switch requirements:
 - a) Gigabit rated (1000 Mbps)
 - b) Non-blocking
 - c) Quality of Service (QoS) with four queues
 - d) Diffserv (DSCP) QoS with strict priority
 - e) The ability to disable EEE (also called Green Ethernet)
 - f) Additional information is available at:
2. Recommended pre-configured switches:
 - a) Yamaha SWP or SWR series; or
 - b) Luxul AMS or XMS series
1. Control booth mixing console position: (1) for connection to console, (2) for temporary/future use
2. Main equipment rack: (1) for connection to switch
3. Orchestra Pit: (1)
4. Down Stage Left – near curtain stacking: (1)
5. Down Stage right – near curtain stacking: (1)
6. Upstage center: (1)

4. MIXING CONSOLE

A. Yamaha QL5; with

1. Yamaha LA1L Gooseneck Console Lamp
2. Yamaha R Series I/O racks in quantity and model necessary to provide analog input/output connections (in addition to I/O on mixing console) for all venue audio inputs.

3. Yamaha RIO-1608-D installed in Gator Cases GRR-4PL-US, or equivalent, (for portable use).

5. WIRELESS MICROPHONES

- A. Shure ULXD – (12 channels); with,
 1. ULXD1 bodypack transmitter (12)
 - a) Avlex HSP-50 Hair/Wig microphone with appropriate wireless bodypack adaptor (1 per transmitter plus 10% spare) **unless specified otherwise**
 2. ULXD2/B58 handheld transmitter (2)
 3. RF Venue Distro4 Antenna Distribution System
 4. RF Venue Diversity Fin remote antenna
 - a) RG-58 coax cable to remote antenna location
- B. Shure Wireless Workbench System Control Software

6. PROGRAM SOURCES

- A. Denon DN-700C CD Player installed in existing control booth rack
- B. AtteroTech unD6IO-BT Dante™ Audio Interface with Bluetooth installed in close proximity to stage touch screen controller

7. EQUIPMENT RACKS

- A. Control Booth: Reuse existing
- B. Amplifier/Equipment Rack: Reuse existing.

8. SOUND REINFORCEMENT LOUDSPEAKER SYSTEM

Left/Right/Mono loudspeaker configuration providing uniform full range audio coverage to most of the seating area. Additional coverage nearfield seating area by way of small-format calibrated, time aligned loudspeakers located on stage lip. Specific loudspeaker model, configurations, and quantities to be confirmed. Amplifier selection based on loudspeaker design. Coordinate loudspeaker placement and orientation with Consultant.

- A. Center Array: ElectroVoice EVA series; standard configuration (4) enclosures
- B. Left/Right Clusters: ElectroVoice EVA series; standard configuration (5) enclosures
- C. Subwoofer: Danley Sound Labs TH-118; standard configuration (2) enclosures suspended immediately upstage of the Center Array
- D. Front Fill Loudspeakers: Innovox HLA Stage Lip series; standard configuration (4) enclosures
- E. Booth Monitoring: ElectroVoice EVU series; standard configuration (3) enclosures
- F. Amplification: QSC CXD-Q Series
 1. Select amplifiers to provide full peak amplification for each loudspeaker circuit per loudspeaker specifications.
 2. Loudspeaker circuits shall not be designed to be below 4Ω nominal impedance.

9. DIGITAL SIGNAL PROCESSING (DSP)

Provides loudspeaker system tuning and calibration along with the ability to provide basic system control, automatic mic control, simplified use, etc. The preferred DSP solution is one portion of a larger integrated system solution which includes DSP, amplification, system control, signal transport, etc.

- A. QSC QSYS Core 510i; with
 1. QSC CDN64 Dante Audio Bridge Card (for integration to Dante digital audio network)
 2. QSC COL Card (2)
- B. Network switch requirements for Q-LAN communication protocol serving control panel, host computer, DSP and amplifier digital audio, control, and monitoring connections:
 1. https://www.qsc.com/resource-files/productresources/dn/3rd_party_control/q_tn_sys_dn_qsys_generalswitchrequirements.pdf

- C. Recommended pre-configured switches
 - 1. QSC NS Series Network Switch for connection to QSC amplifiers

10. MONITOR (FOLDBACK) LOUDSPEAKER SYSTEM

Amplification, integrated cabling and portable loudspeakers used to provide audio reinforcement to on stage performers on an as-needed basis. A minimum of (2) independent monitor mix signals is required. This includes integrated loudspeaker cabling to strategically locate connection plates.

- A. Loudspeakers: Existing
- B. Amplification: QSC CXD-Q Series

11. PRODUCTION INTERCOM

Special event production crews rely heavily on voice communication intercom systems. Performing arts venues such as theaters and concert halls often have permanently mounted connections at critical points around the venue. The standard of design will include a minimum of two (2) independent production intercom channels deployed to strategic locations throughout the venue.

- A. Base Station: Clearcom MS-702 mounted in the control booth location for use by stage manager/technical director.
- B. Belt packs: Clearcom RS-701 single channel belt pack (8); with
 - 1. 15' XLR microphone cable for each belt pack
- C. Headsets: Clearcom CC-300 (9)
- D. Wall Mount Stations: KB-701 (qty. per venue requirements)
- E. Announce Microphone: Shure 514B (in facilities requiring wall mount stations in back of house locations such as dressing room).
- F. Wireless Production Intercom: Clearcom/HME CZ115513 System, including:
 - 1. 5 (five) HS15 headsets
 - 2. BS210 license-free base station w/2 antenna
 - 3. 4 (four) BP210 belt packs
 - 4. 8 (eight) BAT41 batteries
 - 5. 4 (four) pouches
 - 6. AC40A Battery Charger

12. ASSISTED LISTENING SYSTEM

Assistive listening solutions are compliant with government regulations and bring clear, focused, and personalized audio to public spaces.

- A. Transmitter: Listen Technologies LT-800-072-01; with
 - 1. LA-122 Antenna (and cabling per manufacturer's recommendation) Remotely mounted with line of site to majority of auditorium seating.
- B. Receiver: Listen Technologies LR-4200-072 Intelligent DSP RF Receiver (qty as required per ADA regulations – based on venue seating capacity); with
 - 1. LA-401 Universal Ear Speaker (1 per receiver); and
 - 2. LA-166 Neck loop (quantity per ADA requirements); and
 - 3. LA-381 Intelligent 12-Unit Charging Tray (1); and
 - 4. LA-320 Configurable Carrying Case (quantity as necessary to store all provided receivers).

**SECTION 00420
FORM OF AGREEMENT**

PART 1 - GENERAL

1.1 FORM OF AGREEMENT

- A. The Agreement that will be executed by the successful Contractor and Owner consists of the following:
 - 1. AIA Document A107-2004 as amended by Owner
 - 2. The Additions and Deletions Reports for the above.
- B. The individual Documents that will comprise the Agreement between Owner and the Contractor are contained on the pages following this Specification Section.

1.2 LIEN WAIVERS

- A. Partial and Final Waiver and Release of Lien forms to be utilized by the Contractor and Contractor's subcontractors and suppliers are contained in the pages following this Specification Section.
- B. See Specification Section 01200 for Contractor's requirements related to transmission of Partial and Final Waiver and Release of Liens to Owner.

1.3 OTHER FORMS

- A. The Request for Information (RFI) to be utilized by the Contractor are contained in the pages following this Specification Section.
- B. See Specification Section 01200 for Contractor's requirements for the use of and transmission of RFIs.

PART 2 - PRODUCTS (NOT USED)

PART 3 - EXECUTION (NOT USED)

END OF SECTION 00420

**SECTION 01200
CONTRACT SUPPLEMENTAL CONDITIONS**

PART 1 - GENERAL

1.1 SECTION INCLUDES

- A. Work Sequence, Schedule for Completion and Penalties.
- B. Contractor's Construction Schedule
- C. Substantial Completion.
- D. Final Completion.
- E. Application for Progress Payments.
- F. Application for Final Payment.
- G. Changes and Clarifications to the Work
- H. Contractors Administrative Responsibilities.
- I. Project Safety Requirements.
- J. Warranties.
- K. Demolition and Repairs.
- L. Temporary Utilities.
- M. Assignment of the Work.
- N. Manufacturer's Directions.
- O. Storage of Materials.
- P. Use of the Site.
- Q. Measurements.
- R. Occupancy.
- S. Construction by Others.
- T. Runways and Drop Cloths.
- U. Special Working Conditions.
- V. Documents at the Site.
- W. Record Documents.
- X. Project Manual.
- Y. Correction of the Work.
- Z. Hazardous Materials.

1.2 WORKING SEQUENCE, SCHEDULE FOR COMPLETION AND PENALTIES

- A. Contractor and all Subcontractors, and Suppliers shall furnish sufficient forces, construction tools and equipment, and shall work such hours as may be required to insure the execution of the Work in accordance with the Project Milestone Schedule, the Project phasing, the allowable

working hours and the allowable disruptions to Owner's normal use of the facility stated in the Contract Documents. If in the opinion of Owner, the Contractor is not making sufficient progress towards meeting these requirements, the Contractor shall take such steps as may be necessary to improve the progress. Should the Owner deem it necessary to meet these requirements, Owner will require the Contractor to increase the level of staffing, the number of shifts, overtime work and additional days of work including holidays, Saturdays and Sundays, in addition to other measures as necessary all without additional payments to the Contractor.

- B. Owner has the authority to call a progress meeting at the job site at any time. The Contractor's Project Manager is required to attend all such meetings. It is the Owner's intent to hold regular meetings through the course of the Project. Scheduling of these meetings shall be established by Owner prior to the start of the Work.
- C. Substantial Completion shall be achieved per the schedule below. Refer to the Project Milestone Schedule included in these Specifications for additional Project schedule information.

<u>Start Date</u>	<u>Substantial Completion Date</u>
Per Owner	8/7/2020
Notice to Proceed	

- D. At Owner's discretion, Contractor may request an extension to the Substantial Completion date. However, on 8/7/2020, the Wilson Auditorium Audio-Visual, power, and lighting systems must be fully functional regardless of the progress made to that date.
- E. Penalties associated with failure to meet Substantial Completion date will be incurred starting with the calendar day following the Substantial Completion date listed above and accrue each calendar day until Substantial Completion is achieved. Substantial Completion is defined in these Specifications. Owner will assess the Contractor the penalty amounts listed by deducting the total penalty amount from any amounts due to the Contractor by Owner.
- F. If the Contractor incurs a delay due to factors beyond their, their Subcontractors, and their Suppliers control, the Contractor shall submit a claim to Owner, within three (3) weekdays after such occurrence, requesting additional time to achieve Substantial Completion. Failure to submit a claim within the required time will result in a rejection of the claim by Owner.
- G. If a Proposal Request for additional work will require the Contractor additional time to achieve Substantial Completion, the Contractor shall submit with the reply to the Proposal Request a claim for additional time to Owner. The Contractor shall include in the request for additional time sufficient information to demonstrate the cause and to what extent the change will delay obtaining Substantial Completion of the Contract.
- H. The determination that delays have occurred beyond the Contractor's control does not automatically mean an extension of time will be granted. The Contractor must substantiate the delay by indicating suspended Work activities on the critical path of the Contractor's Construction Schedule.
- I. Determination of the date of achievement of Substantial Completion by the Contractor shall be solely the responsibility of Owner.

1.3 CONTRACTOR'S CONSTRUCTION SCHEDULE

- A. Contractor shall, within 7 calendar days after receipt of notice to proceed, submit to Owner the Contractor's construction schedule for the Work. The Contractor's construction schedule shall:

1. Demonstrate compliance with Project Milestone Schedule; Project phasing requirements; and Project allowable disruption to Owner's normal use of the facility.
 2. Include scheduled deliveries of Owner provided equipment and material.
 3. Include scheduled deliveries of Contractor provided equipment critical to the Project schedule.
 4. Include activities and schedule of Contractor's subcontractors.
 5. Be prepared, in sufficient detail, to allow review and approval by the Construction Manager.
- B. Contractor's construction schedule shall be periodically updated to reflect current conditions when directed by Owner and when Project schedule is altered as allowed by Owner.

1.4 SUBSTANTIAL COMPLETION

- A. Substantial Completion as used in the Contract Documents and body of these Specifications shall be defined as follows:
1. AV system is installed, commissioned, and operational.
 2. Owner training has been completed.

1.5 FINAL COMPLETION

- A. Final Completion as used in the Contract Documents and body of these Specifications shall be defined as follows:
1. Substantial completion achieved.
 2. All required tagging, labeling complete and signs installed.
 3. All electrical directories complete.
 4. All construction materials and tools removed from the site and site turned over to Owner "broom clean".
 5. All punch list inspection items completed and approved by Owner.
 6. All inspections and tests required by authorities having jurisdiction completed and approved and submitted to Owner.
 7. All items required to be included with application for final payment delivered to Owner.
 8. Record drawings delivered to Owner.
 9. Owner training schedule established and agreed to by Owner.
 10. Operation and Maintenance Manuals delivered to Owner.

1.6 APPLICATION FOR PROGRESS PAYMENTS

- A. At a time consistent with the requirements of this Section and the Form of Agreement between Owner and Contractor, or as mutually agreed to by the Contractor and Owner, Contractor shall submit a properly executed and notarized Application for Payment.
- B. The amount shown on the Application for Payment shall be established by the value of work completed as stipulated in the Form of Agreement between Owner and Contractor.
- C. The form of application for payment shall be the 1992 edition of AIA Document G702 "Application and Certificate for Payment" and the 1992 edition of AIA Document G703 "Continuation Sheet".
1. Include with Application for Payment a completed Schedule of Values indicating percent of work completed for each item in the Schedule of Values.
 2. Schedule of Values shall provide a detailed breakdown of the Work. Breakdown shall include itemization of all major trades by major segments of the Work and large equipment and material quantities.

- a. Submit Schedule of Values to Owner for approval a minimum of 14 days prior to submitting first Application for Payment. Revise schedule of values as directed by the Owner and resubmit.
- b. Update schedule of values to reflect all approved changes in the Work.
- 3. Materials and equipment shall not be included with Application for Payment until materials and equipment have been delivered to the site. Application for payment shall not include materials and equipment stored off-site.
- D. Owner will not process Contractors 1st application for payment until Contractor has provided Owner all required submittals and all required submittals have been approved by Owner.
- E. Contractors executed and notarized partial or final lien waivers using the forms included in Division 0 shall be submitted with all applications for payment.
- F. Partial or final lien waivers properly executed and notarized by each of the Contractors subcontractors and suppliers shall be submitted with each application for payment.
 - 1. Submit lien waivers for each of Contractors subcontractors and suppliers where total subcontracted amount is \$5,000 or greater.
- G. Contractor warrants that title to all work covered by an application for payment will pass to the Owner at the time of payment.
- H. Contractor warrants all work for which payment has been received from Owner shall, to the best of the Contractor's knowledge, be free and clear of any liens, claims, security interests or encumbrances.
- I. Payments by Owner to the Contractor do not constitute acceptance by Owner of any portion of the Work.

1.7 APPLICATION FOR FINAL PAYMENT

- A. Submit Final Application for Payment following the procedures specified for progress payments and per the following:
- B. Complete the following prior to submitting Application for Final Payment.
 - 1. All work defined as being required to be completed per these Specifications.
 - 2. Forward to Owner all written Warranties provided by the equipment and material manufacturers and suppliers.
 - 3. Forward to Owner copies of Record Drawings, and Operation and Maintenance Manuals.
 - 4. Deliver to location designated by Owner all extra stock and spare parts required by this Contract. Forward acknowledgement of receipt of same to Owner that includes Owner's signature.
 - 5. Prepare and deliver other documents identified in Section 01220 "Contract Closeout".
 - 6. Complete all other requirements to be completed prior to submitting Application for Final Payment identified elsewhere in the Contract Documents.
- C. Include the following with Application for Final Payment.
 - 1. Written confirmation, signed by Owner, of completion of Owner training or a written agreement detailing times and dates that the Owner training will be performed.

1.8 CLARIFICATIONS AND CHANGES TO THE WORK

- A. Request for Information (RFI)
 - 1. If during the performance of the Work clarification of the Contract Documents is required, Contractor shall request such clarification from Owner utilizing the Request for Information

(RFI) form included in these Specifications. Owner shall provide written response to all RFIs and return to the Contractor for distribution to all Contractor's subcontractors.

2. Owner responses to Contractor's RFI's are not authorization to proceed with any work which in the Contractor's opinion requires additional compensation or change to the Project Schedule. If additional compensation or time is required, the Contractor shall immediately submit a Change Order Request to Owner.

B. Proposal Request (PR)

1. Should the Owner contemplate making a change in the Work, Owner will issue a Proposal Request (PR) to the Contractor. If the changes described in the proposal request impact project cost and/or time, the Contractor shall prepare a proposal for submission to Owner. The Contractor's proposal shall include a detailed itemization of costs listing individual material and equipment unit costs and quantities; labor hours and hourly rates for each trade and Contractor and subcontractor mark-ups. Itemization shall include both adds and deducts. The same level of detailed itemization of cost required of the Contractor shall be required of Contractor's subcontractors when subcontractors represents 20% or more of the total cost of the Proposal Request. Owner will review the cost documentation to determine if a Change Order will be issued. Contractor shall not proceed with additional work until authorization has been received in writing from Owner. No additional amount will be paid for preparation or submittal of proposals in this form or for re-submittal should the breakdown or other documentation be considered inadequate by the Owner.
2. The following maximum increases in cost (mark-up) shall be allowed in establishing the total cost of additions and deletions to the scope of the Project:

	Fee not to <u>Exceed</u>
a. To Contractor for work by Contractor's own forces.	<u>10%</u>
b. To Contractor for work performed by other than Contractor's own forces.	<u>5%</u>
c. To Subcontractor for work performed by Subcontractor's own forces.	<u>10%</u>
d. To Subcontractor for work performed by other than Subcontractor's own forces.	<u>5%</u>

3. The above percentages will not be allowed on insurance premiums, taxes or fees. The above percentages include and shall represent all the cost of compiling the general requirements, all supervision and all overhead and profit associated with changes in the scope of the Project.
4. Contractor's response to a Proposal Request shall clearly quantify any change in Contract time that will result if Contractor's response is accepted by Owner. Contractor shall furnish sufficient documentation for changes to the Contract Time to allow review by Owner.
5. Contractor shall provide individual itemized costs and effects on Contract time where a Proposal Request includes multiple changes to the work.

C. Change Order (CO)

1. If the Owner determines that a Proposal Request (PR) or Contractor's Change Order Request will be accepted, Owner will prepare a Change Order (CO) form which will describe the change or changes, will refer to the Owner's Proposal Request or Contractor's Change Order Request, and will be signed by Owner and Contractor. No work associated

with any Change Order is authorized nor will payments be made without a fully executed written Change Order Form.

2. When authorized in writing and in advance by Owner, time and material accounting of a change in work may be used. The Contractor shall maintain an accurate account of labor and material involved in the change. Such time and material records shall be forwarded to Owner, on a daily or weekly basis, per the Owner's direction, for verification prior to Contractor including the change in the Application for Payment. Notify Owner when work on the change is to start and when it has been completed. To receive full recognition, labor assigned to the changes must, insofar as possible, work continuously on the change, rather than interchanging between contract work and the work associated with the change performed using time and material accounting.

D. Construction Change Directive (CCD)

1. A Construction Change Directive is a written order signed by Owner directing a change in the Work prior to agreement on adjustment, if any, in the Contract Sum or Contract Time, or both. Owner may by Construction Change Directive, without invalidating the Contract, order changes in the Work consisting of additions, deletions or other revisions, the Contract Sum and Contract Time being adjusted accordingly.
2. A Construction Change Directive shall be used in the absence of total agreement on the terms of a Change Order.
3. Upon receipt of a Construction Change Directive, the Contractor shall promptly proceed with the change in the Work involved and advise Owner of the Contractor's agreement or disagreement with the method, if any, provided in the Construction Change Directive for determining the proposed adjustment in the Contract Sum or Contract Time.
4. A Construction Change Directive signed by the Contractor indicates the agreement of the Contractor therewith, including adjustment in Contract Sum and Contract Time or the method for determining them. Such agreement shall be effective immediately and shall be recorded as a Change Order.
5. If the Contractor does not respond promptly or disagrees with the method for adjustment in the Contract Sum, the method and the adjustment shall be determined by Owner on the basis of reasonable expenditures and costs of those performing the Work attributable to the change, including, in case of an increase in the contract sum, a reasonable allowance for overhead and profit. In such case the Contractor shall keep and present, in such form as Owner may prescribe, an itemized accounting together with appropriate supporting data.

1.9 CONTRACTORS ADMINISTRATIVE RESPONSIBILITIES

- A. Contractor shall utilize a full time, on-site Project Superintendent, under direct employment of the Contractor, to oversee and coordinate all aspects of the Work required by this Contract.
 1. The Project Superintendent shall have full authority to make decisions for and to act on the behalf of the Contractor without requiring notice to or approval of any of the employees or agents of the Contractor.
 2. Contractor's Project Superintendent shall have a minimum five (5) years experience in the type of work required by this Contract.
 3. Project Superintendent shall be on-site at all times during which work is being performed by the Contractor or their Subcontractors.
 4. Project Superintendent shall be responsible for coordinating all work, schedules and utility interruptions with the Owner's representative.
 5. Project Superintendent shall serve as the primary point of contact between Owner and Contractor's Subcontractors, equipment Suppliers and the Owner's representative.
 6. Project Superintendent shall conduct all construction meetings required by these Specifications.

7. Project Superintendent shall complete and submit to Owner a Daily Work Report using the form included in Division 0.
- B. Contractor shall be responsible for all scheduling of and coordination with all Subcontractors and material Suppliers, including those directly contracted with the Owner, to ensure timely sequencing of the Work, to minimize any disruption to utilities and to the Owner's normal use of the facility; and to ensure work is completed according to the Project Milestone Schedule.
- C. Contractor shall coordinate all work involving Facility utility services and associated local utility companies, to ensure timely sequencing of the work and to minimize interruptions of normal utility service. All fees and costs assessed by the utilities shall be paid by the Contractor and shall be considered work required by the Contract.
- D. Contractor shall be responsible for obtaining approval of all authorities having jurisdiction as described in these Specifications.
- E. Contractor shall coordinate the start-up of all system, sub-systems and equipment. Contractor shall require and schedule the attendance of all Subcontractors performing work related to systems and equipment start-up. Contractor shall notify the Owner a minimum 72 hours in advance of all system and equipment start-up.

1.10 PROJECT SAFETY REQUIREMENTS

- A. All parties involved with this Project are and shall be committed to maintaining a safe worksite and integrating safety into all construction and construction related activities.
- B. It shall be the Contractor's responsibility to identify and comply with all applicable provisions of federal, state and municipal safety laws, regulations, and building codes as they apply to the Work required by this Contract. Contractor shall be responsible for the safety of the Contractor's employees, agents, suppliers and Subcontractors.
- C. Prior to beginning any on-site activities the Contractor shall develop a Project specific written Safety Program. The Safety Program shall:
 1. Identify the Contractor's standard safety policies, procedures and employee training.
 2. Identify hazards specific to the Work required by this Project, such as crane use, open shafts, excavation, fall protection and confined spaces; and the procedures and policies that will be used to protect workers and the public.
 3. Identify hazards specific to the Work required by this Project that may pose risks to the Owner's employees, agents, and the public; and the procedures and policies that will be used to notify and protect the Owner's employees, agents, and the public.
 4. Establish schedule of weekly "toolbox" safety meetings and identify personnel that will conduct the meetings. Owner's personnel will also attend the weekly meetings.
 5. Identify the Contractor's employee that will be responsible for maintaining a safe worksite and enforcing Contractor's general and Project specific safety policies and procedures.
 6. Address other topics that may be requested by the Owner.
- D. Project Safety Program shall be submitted to the Owner prior to the Contractor beginning any on-site activities.
 1. A sample job hazard analysis is included at the end of this Specification Section.
- E. Contractor shall provide, at Owner's request, a copy of the topics addressed during the weekly safety meeting and a list of the meeting attendees.
- F. The Owner may, at the Owner's sole discretion, require the Contractor to submit written incident reports to the Owner, using a format acceptable to the Owner. Reporting requirements may include any of the following:

1. Injury accidents.
 2. "Near Miss" incidents.
 3. Non-injury accidents involving damage to property, materials or equipment.
- G. Contractor shall periodically perform inspections of all areas of the Project site to verify safety policies and procedures are fully in place and to identify and remedy any unsafe conditions, construction methods or other hazards. Frequency of inspections shall be as needed to maintain a safe worksite.

1.11 WARRANTIES

A. Project Warranty:

1. The Contractor shall provide a one year warranty for all materials, equipment, and labor furnished by the Contractor under this Contract. Contractor's warranty shall include all materials, parts, labor and all other costs necessary to honor the warranty. Contractor warrants that the Work is free from defects in material and workmanship, complies with the Contract Documents and is 100 percent complete including all remedies to the Work identified by Owner.

B. Other Warranties:

1. Disclaimers and Limitations: Any of the Contractor's Equipment Manufacturers, Materials Supplier's or Subcontractor's disclaimers and limitations on product or installation warranties not in compliance with specified Project Warranty do not relieve the Contractor from providing the specified Project Warranty.

C. Warranty Requirements:

1. Related Damages and Losses: When required to be corrected under the Project warranty, Contractor shall remove and replace construction that has been damaged as a result of such failure or must be removed and replaced to provide access for correction of warranted construction.

D. Commencement of Warranty Period:

1. Warranty period shall commence at time Final Completion is achieved as defined in these Specifications and as determined by Owner.
2. Owner shall issue in writing to Contractor warranty start and end dates.

1.12 DEMOLITION AND REPAIRS

- A. All equipment and material removed during the performance of the Work shall be presented to the Owner. Equipment and material accepted by the Owner shall be delivered to a location on the site designated by the Owner. All equipment and material not accepted by the Owner shall be deemed property of the Contractor, shall be promptly removed from the site, and shall be legally disposed of by the Contractor.
- B. Contractor shall be responsible for removal and reinstallation of all existing building structure, fixtures, finishes, and other building components (i.e., ceiling, walls, light fixtures, roofing, windows and doors, etc.) required to perform the Work.
- C. Contractor shall repair all building structure, improvements, permanent and moveable fixtures and finishes including paving and landscaping damaged as a result of Work performed under this Contract using skilled tradesmen and materials matching existing structure, improvements, fixtures and finishes. All repairs shall be completed to the satisfaction of the Owner.

1.13 TEMPORARY UTILITIES

- A. Temporary Electric Power: Electric power for equipment and power tools may run from Owner's existing service. Contractor to provide all materials and labor necessary to connect to existing service. Location of connection to existing service is to be at Owner's convenience and direction.
- B. Temporary Water: Water will be provided by Owner from Owner's existing service. Location of connection is to be at Owner's convenience and direction.
- C. Sanitary Agreements: Owner will allow workmen to use only those toilets, sinks and drinking fountains in the existing Facility designated by the Owner.

1.14 ASSIGNMENT OF THE WORK

- A. The division of the body of the Specifications into various sections or headings and the assignment of the Work to individual drawings and the use of drawing numbers and titles has been arranged for clarity in the delineation of the various parts of the whole work. It is not the intent of each Specification Section, each Drawing nor each drawing number or title to develop any secondary responsibilities for the satisfactory completion of the Work; nor is the assignment by Owner of any parts of the Work to any specific trade or craft to be inferred from the Specifications or the Drawings. Contractor is fully responsible for providing all work required by this Contract.

1.15 MANUFACTURER'S DIRECTIONS

- A. All Manufacturer's materials and equipment shall be applied, installed, connected, erected, used, cleaned and conditioned as recommended by the Manufacturer unless otherwise specifically directed by Owner or specified herein.

1.16 STORAGE OF MATERIALS

- A. All materials delivered to the job shall be stored so as to keep them in first class condition and free from deterioration. Equipment and material shall be stored as recommended by the manufacturer. Steel shall be stored on racks at least 6 inches from the ground, and shall be protected from the weather. In general, material deliveries shall be coordinated with the progression of work to avoid prolonged storage of materials or equipment at job site. On-site storage of equipment, materials and tools shall be only in locations and for durations identified by the Owner.

1.17 USE OF THE SITE

- A. Rubble, trash, demolished or removed materials and equipment shall not be stored on the site or left unattended and shall be disposed of daily in a manner approved by the Owner.
- B. Contractor's and subcontractor's employees shall park personal and company vehicles only in the locations designated by the Owner.

1.18 MEASUREMENTS

- A. Before ordering any materials or equipment or doing any work, the Contractor shall verify all measurements at the site and shall be responsible for the correctness of same. No extra charge shall be allowed on account of the differences between actual measurements and those indicated on the Drawings.

1.19 OCCUPANCY

- A. All areas of building shall remain occupied by the Owner during the performance of the Work except those specific areas where work is actually being performed as identified by the Contract Documents. Contractor shall notify Owner 7 days in advance of need to interrupt Owner's normal occupancy and use of areas involved in this Contract, or any other areas within the Facility, and shall perform the work in such a manner to minimize all such interruptions.
- B. Occupancy or use of a portion or portions of the Work by the Owner shall not constitute acceptance of Work not complying with the Contract Documents.

1.20 CONSTRUCTION BY OTHERS

- A. Owner reserves the right to perform construction and construction related work at the site with their own forces and with other contractors.
- B. Contractor shall fully cooperate with the Owner so that neither the Contractor's work nor work performed by the Owner is adversely affected. Cooperation shall include coordination, exchange of information, attending meetings and efforts as necessary by both the Contractor and the Owner's employees and contractors.
- C. Contractor shall not restrict the Owner and their Subcontractor's access to or use of the site, nor inhibit in any way their ability to meet their contractual obligations.

1.21 RUNWAYS AND DROP CLOTHS

- A. Whenever Contractor's performance of the Work requires them to work in proximity to or in direct contact with any finishes, furnishing or furniture, Contractor shall protect such finished work using the best possible practices.

1.22 SPECIAL WORKING CONDITIONS

- A. The Contractor will recognize the presence of employees, visitors and other members of the public at the site and shall employ adequate precautions to protect the employees, visitors and the public from all hazards associated with the Work and to protect the Work from damage. "Spotters" shall be utilized when equipment is being installed or removed.
- B. Contractor's materials, tools, equipment and construction apparatus shall not be left unlocked or unprotected. Contractor's workmen shall be instructed to keep small tools in their personal possession or observation at all times. Neither the Owner nor the Construction Manager assume responsibility for the Contractor's materials, tools, equipment or construction apparatus used or stored at the site.
- C. The Owner's building engineering staff and administrators shall be consulted as to any hazards particular to this site, this facility and the Work. Contractor shall comply with all directions given by the Owner and the Owner's designated representatives.
- D. No firearms or other weapons, explosives, intoxicating beverages or narcotics shall be carried on, or used on the Owner's property. Contractors and all Subcontractors shall adhere to Owner's tobacco use policy.
- E. There shall be no fraternization with visitors or employees on the job.
- F. Contractor shall recognize the fact that most employees of the Owner are non-union personnel and that such fact shall not be considered as excuse for delay in the Work. Contractor, its

agent, Subcontractors, employees and Suppliers shall not interfere in any manner with the labor relations between Owner and its employees. In no case will any responsibility of the Contractor to employ union labor be extended to Owner, nor will the work performed by Owner's employees, whether union or non-union, be interfered with by Contractor, its employees, Subcontractors, agents or suppliers.

- G. The Contractor shall be responsible for informing all of their personnel and employees, Subcontractors, Suppliers and related employees of the "Special Working Conditions".

1.23 DOCUMENT AT THE SITE

- A. Contractor shall maintain at the site one record set of the Drawings, Specifications, Addenda, Change Orders, RFIs, and all approved submittals. Contractor shall continuously update and mark these documents to reflect actual installed condition and locations (both horizontally and vertically) and all approved changes issued by Owner.
- B. These documents maintained at the site shall become the basis of the Contractor's preparation of the Project Record Drawings and Project Manual.

1.24 RECORD DOCUMENTS

- A. Prepare "as-built" record documents for all mechanical, fire protection, medical gas, plumbing and electrical systems. Record drawings shall be provided using AutoCAD (most current version). Provide both hard copies and electronic copies on CDROM's as part of record Drawings. Record Drawings shall be updated shop drawings or Drawings issued for Bid and shall include:
 - 1. Record Drawings shall represent actual installed condition of all work.
 - 2. Ductwork mains and branches, type, size, location, and elevation for both exterior and interior; locations of fire, smoke, combination fire/smoke, balancing, backdraft and other types of dampers or louvers, and other control devices; filters; grilles and diffusers with airflow rates and devices requiring periodic maintenance or repair, turning vanes, access doors, air terminal units and all other devices located in or connected to ductwork systems.
 - 3. Mains and branches of all piping systems, type, size, locations and elevation with valves and control devices located and numbered to match valve schedule, with items requiring maintenance located (i.e., traps, strainers, expansion compensators, mixing valves, etc.). Indicate actual inverts and locations of all underground piping.
 - 4. Equipment locations (exposed and concealed), dimensioned from prominent building lines.
 - 5. Approved substitutions, Contract Modifications, and actual equipment and materials installed.
- B. Owner will provide Contractor with AutoCAD Drawing files for use by the Contractor in maintaining, preparing and submitting final Record Drawings.

1.25 PROJECT MANUAL

- A. Assemble and submit at completion of the Project, a Project manual that includes at a minimum all of the following:
 - 1. All RFI's with Owner's responses.
 - 2. Copies of all approved submittals, including all shop Drawings.
 - 3. Copies of all test reports.
 - 4. Copies of all reports by inspectors representing authorities having jurisdiction. Include initial and final reports and any Contractor responses to same.
 - 5. Copies of all system, equipment, etc. start-up reports.

6. Other information that may be useful or required by Owner necessary to document the work performed under this contract.

1.26 CORRECTION OF THE WORK

- A. Contractor shall correct any Work rejected by Owner for failure to comply with the Contract Documents, whether discovered before or after the Work has been covered by subsequent Work, whether or not inspected by Owner and whether or not the Work has been determined to be substantially or finally complete.
- B. Contractor shall bear the full cost of correcting the Work to bring the Work into compliance with the Contract Documents. Cost of correction shall include all costs associated with:
 1. Uncovering and recovering the Work.
 2. Recovering and replacing the non conforming Work
 3. Any re-inspections, acceptances, certifications and approvals required by authorities having jurisdiction and by the Contract Documents.
 4. Revisions to Record Documents.

1.27 HAZARDOUS MATERIALS

- A. Contractor shall comply with the Contract Documents and all laws, standards and handling criteria regarding hazardous materials, substances and wastes, including asbestos, lead-based paints, petroleum products, mold, radon and polychlorinated biphenyl (PCB) in performing the Work. No hazardous materials shall be brought onto the Project site or otherwise incorporated into the Work by any of the Contractor parties. In the event hazardous materials are encountered that are not addressed in the Contract Documents, Contractor shall immediately (1) stop Work in the affected area, (2) report the condition to the Owner both verbally and in writing and (3) take all reasonable precautions to prevent or contain the movement, spread or disturbance of the suspected hazardous materials and to protect all persons and property. Once the Owner has investigated and, if necessary, properly remediated, abated or contained the suspected hazardous material, Work in the affected area shall resume. Provided the Contractor fulfills its obligations herein, The Contract Time shall be extended appropriately by Change Order.

PART 2 - PRODUCTS (NOT USED)

PART 3 - EXECUTION (NOT USED)

END OF SECTION 01200

**SECTION 01220
CONTRACT CLOSEOUT**

PART 1 - GENERAL

1.1 SUMMARY

- A. This Section includes requirements for Contract closeout and related matters.
- B. All documents described in this Section of the Specifications shall be submitted to the Owner prior to Owner making final payment to Contractor.

1.2 CLEAN UP

- A. At the completion of work, remove all temporary facilities, unused materials, tools, equipment, trash and debris from the site. Leave the site clean, neat and ready for full and normal use by the Owner.

1.3 OPERATION AND MAINTENANCE MANUALS

- A. Submit Operation and Maintenance Manuals to Owner for approval. Organize operating and maintenance data into suitable sets of manageable size. Bind and properly index data in individual heavy-duty, 3-ring, vinyl covered binders, with pocket folders for folded sheet information. Mark appropriate identification on front and spine of each binder. Include the following types of information:
 - 1. Emergency instructions.
 - 2. Spare parts list.
 - 3. Copies of warranties.
 - 4. Control and wiring diagrams.
 - 5. Recommended "turn around" cycles.
 - 6. Inspection and Maintenance procedures.
 - 7. Shop Drawings and Product Data.
 - 8. One copy of all submittals and "As Built" Drawings.

1.4 FINAL INSPECTION REPORT

- A. Submit to Owner a report detailing actions taken by Contractor as a result of Owner's final project inspection. Contractors report shall detail action taken for each individual item included in Owner's final inspection report. Include a copy of Owner's inspection report with Owners signature verifying completion of remedial actions with Contractor's submission.

1.5 OTHER DOCUMENTS

- A. See Section 01200 for other documents to be submitted with Application for Final Payment. Documents identified in Section 01200 include:
 - 1. Record Drawings.
 - 2. Project Manual.
 - 3. Lien Waivers.
 - 4. Owner Training Verification.
 - 5. Extra Stock and Spare Parts.
 - 6. Project and Other Warranties.

END OF SECTION 01220

SECTION 01330
PERMITS, REGULATIONS AND TAXES

PART 1 - GENERAL

1.1 CONTRACTORS RESPONSIBILITIES

- A. The Contractor shall be responsible for obtaining and paying for any and all permits, licenses, plan reviews, inspections, etc, including building permits, required by all authorities having jurisdiction over the Work required by this Contract.
- B. Contractor shall arrange and pay for any and all inspections required by non-governing authorities having jurisdiction over the Work, including any utility companies, as required by the Work.
- C. Owner is a not for profit entity and such is not subject to sales and similar taxes. Contractor shall not be required to make such tax payments for this project. Successful bidder will be provided with proof of Owners tax exempt status prior to award of the Contract.
- D. All work shall be in full compliance with the building codes, ordinances and regulations adopted by all governing bodies having jurisdiction over the Work required by this Contract.
 - 1. The Contractor shall promptly notify Owner if the Contractor observes that any portions of the Contract Documents are at variance with the codes, ordinances and regulations governing the Work. Owner shall take such actions necessary to bring the Work into compliance.
- E. Contractor shall, after obtaining approval of submittals from Owner, forward any and all required information to any authority having jurisdiction, including but not limited to local and State Fire Marshals, as required to obtain approval of same.
- F. The Contractor and all Subcontractors performing work under this Contract shall fully comply with the provisions of the Federal Occupational Safety and Health Act and the rules and regulations promulgated pursuant to this Act.
- G. Contractor shall comply with or warrant:
 - 1. Contractor represents and warrants that neither it nor any of the other Contractor Parties will employ or use any individual to perform Work who is not legally authorized to work in the United States in the capacity required to perform such Work. Contractor further certifies that all employees and other individuals performing Work are legally authorized to work in the United States in the capacity required to perform the Work and will provide upon request written documentation to support such certification. Contractor shall indemnify, hold harmless and, if the Owner elects, defend Owner from and against all claims, damages, losses and expenses arising out of any alleged failure of Contractor to comply with its warranties, representations, and certifications under this paragraph.
 - 2. Contractor shall maintain, preserve and make available to Owner for at least six years after final payment, records of all costs incurred by Contractor arising out of or relating to the Work, including invoices, vouchers, checks, receipts, time sheets, accounts, cost reports, contracts, inspections, tests, lien waivers and releases. Upon reasonable notice, Owner shall have the right to audit all of the Contractor's books and records with respect to the Project.

PART 2 - SUBCONTRACT AGREEMENTS

- A. Contractor agrees to include all the provisions contained in Specification Section 01330 in each of its agreements with all subcontractors for work or services to be performed for the Project.

PART 3 - PRODUCTS

(NOT USED)

PART 4 - EXECUTION

(NOT USED)

END OF SECTION 01330

**SECTION 01340
TESTS AND INSPECTIONS**

PART 1 - GENERAL

1.1 CONTRACTOR'S RESPONSIBILITIES

- A. Contractor shall arrange for and pay for all tests, inspections and approvals, associated with the Work, required by the Contract Documents, by laws, or by any authorities having jurisdiction over the Work.
- B. All required tests and inspections shall be scheduled and obtained by the Contractor matching the sequence of the Work to ensure Work is completed per the Project Milestone Schedule.
- C. Contractor shall forward to Owner all certificates or notices of all tests and inspections, including the results of tests and inspections, issued by the entities performing the tests and inspections. Where such entities do not issue certificates and/or results of tests and inspections, Contractor shall provide a written report to Owner detailing:
 - 1. Date and time of test or inspection.
 - 2. System or equipment tested or inspected.
 - 3. Entity performing test or inspection, including contact name and contact information.
 - 4. Results of test or inspection.
 - 5. Any remedial actions identified by the entity performing the test or inspection.
- D. Contractor shall perform all remedial actions identified by the entity performing the test and/or inspection; and shall perform any other work required to obtain the approval of the entity performing the test and/or inspection. No additional payments shall be made to the Contractor, nor shall any extensions to the Project Milestone Schedule be granted where required remedial actions are Work required by the Contract Documents.

PART 2 - PRODUCTS

(NOT USED)

PART 3 - PART 3 – EXECUTION

(NOT USED)

END OF SECTION 01340

**SECTION 01420
SUBMITTALS**

PART 1 - GENERAL

1.1 SUMMARY

- A. This Section includes administrative and procedural requirements for submittals required for performance of Work.
 - 1. See individual specification sections for submittal requirement specific to each product, material, equipment or service required by the Work.
 - 2. Contractor shall, prior to forwarding a submittal, review each submittal to ensure the information required to be included in the submittal (as identified in each specific section) is in fact included.
 - 3. Submittals that do not include all required information (as identified in each specification section) will be returned to the Contractor without review.

1.2 SUBMITTAL PROCEDURES

- A. Engineer will provide Contractor with a project submittal log identifying all submittals required to be furnished by the Contractor to Engineer and Owner.
 - 1. Engineer will maintain Project Submittal Log to reflect current status of all submittals required to be furnished by the Contractor. Contractor may request a copy of the Project Submittal Log at any time during the project.
- B. All submittals shall be forwarded to the Engineer electronically using read only PDF files. Large submittals shall utilize multiple PDF files with each individual PDF file being clearly named (describing contents of file) and limited to a maximum file size of 8 MB.
 - 1. Each submittal shall include an Owner transmittal cover sheet. Owner will provide Contractor with a master transmittal cover sheet.
 - 2. Submittals shall be emailed to: Ciarra.king@hendersonengineers.com
 - 3. Email Subject Line: Wilson Auditorium AV Upgrades – Phase 2
- C. Processing: Allow sufficient review time so that the Project will not be delayed as a result of the time required to process submittals, including time for required re-submittals.
 - 1. Allow 7 calendar days for Engineer's MEP submittal review. Allow additional time if processing must be delayed to permit coordination with subsequent and related submittals.
 - 2. No extension of Contract Time will be authorized due to Contractor's failure to transmit submittals to Engineer sufficiently in advance of the Contractor's need for approved submittals based on the Contractor's Project Schedule.
- D. Clearly mark each submittal to show applicable choices, options and accessories provided. Where printed Product Data includes information on several products, some of which are not required, mark copies to indicate the information applicable to the product or material supplied. Submittals not marked to show applicable choices will be returned for revision. Include the following information with each submittal where applicable. See each Section of these Specifications for additional information to be included with each submittal.
 - 1. Manufacturer's printed installation and application recommendations.
 - 2. Compliance with specified trade association's standards.
 - 3. Compliance with specified testing agencies, Codes and Standards requirements.
- E. Contractors Review: Review each submittal and check for coordination with other Work of the Contract and for compliance with the Contract Documents prior to forwarding to Owner. Note any corrections and required field dimensions on body of submittal.

- F. Approval Stamp: Stamp each submittal with a Contractor's approval stamp. Include Project name and location, submittal number, Specification Section number and title, name of reviewer, date of Contractor's approval and statement certifying that submittal has been reviewed, checked and approved by the Contractor for compliance with the Contract Documents.
- G. Organize and forward submittals to Engineer by individual Specification Section. Provide a minimum of one submittal per Specification Section.

1.3 ENGINEER'S ACTION

- A. Engineer will review each submittal, will revise submittal as required to comply with the Contract Documents and will mark with Action Stamp.
- B. Engineer will return reviewed submittal electronically using the same file format as used by Contractor.
- C. Action Stamp: Each submittal will be stamped with a uniform, self-explanatory action stamp. The stamp will be appropriately marked, as follows, to indicate the action taken:
 - 1. "1" – Approved: When submittal is marked "Approved" that part of the Work covered by the submittal process may proceed.
 - 2. "2" – Approved as Corrected: When submittal is marked "Approved as Corrected", that part of the Work covered by the submittal may proceed provided all submittal review notes are fully complied with, without exception.
 - 3. "3" – Revise and Resubmit: When submittal is marked "Revise and Resubmit", do not proceed with that part of the Work covered by the submittal, including purchasing, fabrication, delivery or any other activity. Prepare a NEW submittal in accordance with all submittal review notes and specified requirements; resubmit without delay.
 - 4. "4" – Rejected: Where submittal is marked "Rejected", submittal has been rejected without review for compliance with specifications. Do not proceed with that part of the Work covered by the submittal, including purchasing, fabrication, delivery or any other activity. Prepare a NEW submittal showing full compliance with the specified requirements; resubmit without delay. Contractor shall perform no portion of the Work that requires the Contractor to obtain approved submittals until such approval has been obtained from Owner.
 - 5. "5" – Not Reviewed: Where submittal is marked "Not Reviewed". Submittal will be returned with an explanation as to why the submittal was not reviewed.
 - 6. "6" – For Information Only: Where submittal is primarily for information or record purposes, special processing or other activity, the submittal will be returned, marked "For Information Only". Resubmittal is not required.
 - 7. "7" – See Attached Review by Others: Submittal was reviewed by an Owner retained consultant. Follow the submittal actions directed by the consultant.
- D. Review of submittals shall be for compliance with Drawings, schedules, Specifications and design intent. Approval of a submittal or any portion of a submittal shall not be interpreted as approval of the following information included in the submittal:
 - 1. Quantities (i.e. number, lengths, volumes, square feet, weights, etc.)
 - 2. Dimensional compatibility with installed locations.
 - 3. Methods of factory and/or field assembly.
 - 4. Transport, storage, rigging, installation, start-up and testing methods.
 - 5. Warranties in conflict with specified warranties.
 - 6. Payment terms in conflict with specified terms.
- E. Contractor's first Pay Application will not be processed until all required submittals have been received and approved by Engineer and Owner.

1.4 SUBMITTALS TO AUTHORITIES HAVING JURISDICTION

- A. Contractor shall be responsible for preparing and submitting calculations, shop drawings, product data and all other required documents to all authorities whose approval must be obtained to perform and accept the Work.
- B. Format and number of copies shall be as required by reviewing authorities. Engine shall be provided with one copy of all such submissions concurrent with submission to reviewing authority.
- C. Contractor shall provide the Engineer one copy of all approved submissions (with proof of reviewing authority's approval). Contractor shall provide the Owner with one copy of all field inspection and field test reports issued by the reviewing authorities.
- D. Documents required by paragraphs A, B and C above shall be included in the Project Manual detailed in Section 01200.

PART 2 - PRODUCTS

(NOT USED)

PART 3 - EXECUTION

(NOT USED)

END OF SECTION 01420

SECTION 01530
WORKING HOURS, UTILITY INTERRUPTIONS AND PROJECT PHASING

PART 1 - GENERAL

1.1 BASIS OF BID

- A. Contractor shall prepare the bid and execute the Work based on conducting all work to be performed at the site only during the allowable working hours specified in this Specification Section and detailed elsewhere in the Contract Documents.
- B. Contractor shall prepare the bid and execute the Work requiring utility interruptions per the requirement of this Specification Section and detailed elsewhere in the Contract Documents.
- C. Contractor shall prepare the bid and execute the Work utilizing the Project Phasing requirements of this Specification Section and detailed elsewhere in the Contract Documents.

1.2 ALLOWABLE WORKING HOURS

- A. Allowable Working Hours: Allowable working hours shall be defined as those hours during which Contractors, material Suppliers, technicians, and startup personnel may have access to various interior and exterior areas at the site for the purpose of performing all work required by this Contract.
- B. Normal Business Hours: 6:30am to 4:30pm; Monday through Friday. Not all work required to complete the Project can be performed during normal business hours. Work required to be performed outside normal business hours is identified later in this Specification Section.
- C. Application: All work performed at the site, both within the Facility and exterior to the Facility, by the Contractor, by all Contractor's Subcontractors and by all other Contractor's Partners shall be performed only during the specified allowable working hours.
- D. Verification of allowable working hours shall be the responsibility of the Contractor prior to the start of any work required by this Contract. Verification shall include the following:
 - 1. Contractor shall meet with Owner's representative to detail the type of work to be performed in each area where work will be performed within and exterior to the facility.
 - 2. Contractor shall obtain, from Owner's representative, Owner's normal occupancy and utilization schedules for all areas within the Facility that will be affected by work required by this contract.
 - 3. Contractor shall then establish allowable working hours, for each type of work in each individual area in which work is to be performed. All allowable working hours shall be approved by Owner.
 - 4. Contractor shall prepare a written description of allowable working hours for each type of work in each individual area in which work is to be performed. Written description shall be distributed to all Subcontractors, all other Contractor's Parties, to the Owner.
- E. In general, Owner will allow the Contractor to perform work in the following areas during normal business hours, if work performed by the Contractor does not adversely affect in any manner Owner's normal use of the Facility, nor create objectionable noise, dust or other disturbances.
 - 1. Mechanical and electrical rooms.
 - 2. Exterior to the Facility excluding work associated with exterior equipment such as rooftop air handlers, cooling towers, utility services, roadways, parking lots, etc.
 - 3. Other areas specifically as identified by the Owner.
- F. Owner reserves the right to require Contractor to immediately cease any work in any location should said work produce noise, dust, fumes or in any other manner interfere with Owner's

normal or required use of the Facility; or creates any unacceptable interruption in the normal operation of any mechanical, electrical, plumbing or fire protection and alarm systems or other required systems.

- G. Owner reserves the right to require Contractor to cease work in any area Owner requires access to on an emergency basis.
- H. Contractor shall maintain contingency work plans should Owner be required to alter allowable working hours on short notice or require Contractor to cease work as previously described. Contractor contingency plan shall allow efficient use of their personnel in other areas or perform other portions of the Work when Owner exercises the right to deny Contractor access to specific areas. Additional payment to the Contractor will not be allowed as a result of Owner's denial of access to areas within the Facility.
- I. Contractor's and Subcontractor's personnel may, at the Owners discretion, be allowed access to the area within the Facility during times other than during specified allowable working hours to perform the following:
 - 1. Taking of measurement, inventory, etc., as required to order product and materials and to shop fabricate items for field installation.
 - 2. Making general observations related to scheduling of work and product and material deliveries.
 - 3. Receiving products and materials that cannot be delivered during allowable working hours.
 - 4. Owner will require Contractors to immediately cease work associated with items 1, 2 and 3 above should said work produce noise, dust, fumes or interfere in any way with Owner's normal and required use of the Facility.
 - 5. All work listed for items 1 through 4 above shall be scheduled in advance with the Owner.
- J. Delivery of material and products shall be scheduled to occur during normal business hours. Where deliveries cannot occur during allowable working hours, Contractor shall coordinate delivery times and location with Owner, a minimum of 72 hours in advance of delivery. Owner shall identify allowable areas of on-site temporary storage and allowable maximum storage period. Materials and products shall be set in final installed location only during allowable working hours.

1.3 UTILITY INTERRUPTIONS

- A. Definition: Utility interruptions shall be defined as any disruption to the normal operation of the following MEP systems caused by the Contractor in order to perform the work required by this contract.
 - 1. HVAC Systems:
 - a. Heating
 - b. Cooling
 - c. Airflow
 - d. Exhaust
 - e. Temperature control systems
 - 2. Plumbing Systems:
 - a. Domestic cold and hot water
 - b. Sanitary drainage
 - c. Storm drainage
 - d. Fire protection
 - e. Natural gas
 - 3. Electrical Systems:
 - a. Normal and emergency power
 - b. Lighting
 - c. Phone/data/communications

- d.* Local and facility P/A
 - e.* Security
 - f.* Cable and satellite television
 - g.* Fire detection
 - h.* Fire annunciation
- B. All disruptions of utility services shall be performed only during hours specified later in this Specification Section or where not specified only during hours identified by the Owner. Contractor shall establish allowable time periods for utility interruptions using methods similar to that described for establishing allowable working hours (Section 1.2).
 - C. All interruptions shall be as short in duration as possible. Any service interrupted shall be restored to full operation as soon as practical and at a minimum shall be restored to full operation a minimum of 2 hours prior to Owner occupancy or normal use of space or system affected by interruption.
 - D. All interruptions shall be scheduled with Owner a minimum of 7 days in advance of interruption.
 - E. Contractor shall schedule the work in such a manner as to minimize the number of utility interruptions required to perform the Work.

1.4 SPECIAL WORKING HOURS

- A. No Work in project scope is identified as requiring special working hours.

1.5 DRAWINGS AND SPECIFICATIONS

- A. Additional requirements for project phasing, allowable working hours and utility interruptions may be identified in other Sections of these Specifications and on the Drawings.

END OF SECTION 01530

**SECTION 01600
CUTTING AND PATCHING**

PART 1 - GENERAL

1.1 SUMMARY

- A. This Section includes procedural requirements for cutting and patching.

1.2 DEFINITIONS

- A. Cutting: Removal of existing construction necessary to permit installation or performance of the Work.
- B. Patching: Restoration and repair work required to restore surfaces to original conditions after installation of the Work.

1.3 QUALITY ASSURANCE

- A. Structural Elements: Do not cut and patch structural elements in a manner that could change their load-carrying capacity or load-deflection ratio.
- B. Operational and Miscellaneous Elements: Do not cut and patch elements and related components in a manner that results in reducing their capacity to perform as intended or that results in increased maintenance or decreased operational life or safety.
- C. Visual Requirements: Remove and replace construction that has been cut and patched in a visually unsatisfactory manner.
- D. Rated Construction: Cut and patch existing elements that are fire and/or smoke rated using methods and materials that maintain the existing rating and that are approved by authorities having jurisdiction.

PART 2 - PRODUCTS

2.1 MATERIALS

- A. Existing Materials: Use materials identical to existing materials. For exposed surfaces, use materials that visually match existing adjacent surfaces to the fullest extent possible.
 - 1. If identical materials are unavailable or cannot be used, use materials that, when installed, will match the visual and functional performance of existing materials and that are approved in advance by the Owner.

PART 3 - EXECUTION

3.1 EXAMINATION

- A. Examine surfaces to be cut and patched and conditions under which cutting and patching are to be performed.
 - 1. Compatibility: Before patching, verify compatibility with and suitability of substrates, including compatibility with existing finishes.
 - 2. Proceed with installation only after unsafe or unsatisfactory conditions have been corrected.

3.2 PREPARATION

- A. Temporary Support: Provide temporary support of Work to be cut.
- B. Protection: Protect existing construction during cutting and patching to prevent damage. Provide protection from adverse weather conditions for portions of Project that might be exposed during cutting and patching operations.
- C. Adjoining Areas: Avoid interference with use of adjoining areas or interruption of free passage to adjoining areas.
- D. Existing Services: Where existing services are required to be removed, relocated or abandoned, bypass such services before cutting to minimize interruption of services to occupied areas using methods approved by the Owner.

3.3 PERFORMANCE

- A. General: Employ skilled workers to perform cutting and patching. Proceed with cutting and patching at the earliest feasible time, and complete without delay.
 - 1. Cut existing construction to provide for installation of other components or performance of other construction and subsequently patch as required to restore surfaces to their original condition.
- B. Noise and Dust Generating Operations: Coordinate noise and dust generating operations with the Owner and Owners Facility Specific Procedures (01510) to minimize disturbance to normal operations. Noise and dust generating operations may be required to be conducted at other than normal working hours.
- C. Cutting: Cut existing construction by sawing, drilling, breaking, chipping, grinding and similar operations, including excavation, using methods least likely to damage elements retained or adjoining construction. If possible, review proposed procedures with original Installer, and comply with original Installer's written recommendations.
 - 1. In general, use hand or small power tools designed for sawing and grinding, not hammering and chopping. Cut holes and slots as small as possible, neatly to size required, and with minimum disturbance of adjacent surfaces. Temporarily cover openings when not in use.
 - 2. Existing Finished Surfaces: Cut or drill from the exposed or finished side into concealed surfaces.
 - 3. Concrete and Masonry: Cut using a cutting machine, such as an abrasive saw or a diamond-core drill.
 - 4. Proceed with patching after construction operations requiring cutting are complete.
- D. Patching: Patch construction by filling, repairing, refinishing, closing up and similar operations following performance of other Work. Patch with durable seams that are as invisible as possible. Provide materials and comply with installation requirements specified in other Sections of these Specifications.
 - 1. Inspection: Where feasible or required, test and inspect patched areas after completion to demonstrate integrity of installation.
 - 2. Exposed Finishes: Restore exposed finishes of patched areas and extend finish restoration into retained adjoining construction in a manner that will eliminate evidence of patching and refinishing.
 - 3. Floors and Walls: Where walls or partitions that are removed extend one finished area into another, patch and repair floor and wall surfaces in new space. Provide an even surface of uniform finish, color, texture and appearance. Remove existing floor and wall coverings and replace with new materials, if necessary, to achieve uniform color and appearance.

- a. Where patching occurs in a painted surface, apply primer and intermediate paint coats over patch and apply final paint coat over entire unbroken surface containing the patch. Provide additional coats until patch blends with adjacent surfaces.
 - b. Perform work to maintain existing fire and smoke ratings.
4. Ceilings: Patch, repair or re-hang existing ceilings as necessary to provide an even-plane surface of uniform appearance.
5. Exterior Building Enclosure: Patch components in a manner that restores enclosure to a weather tight condition.
6. Rated Construction: Where cutting and patching rated construction fully restore fire and/or smoke rating of existing construction using only materials and methods acceptable to authorities having jurisdiction. Obtain and pay for any required inspections after completion of restoration.

END OF SECTION 01600

CONTRACTOR'S AFFIDAVIT AND FINAL WAIVER AND RELEASE OF LIEN

- A. OWNER: _____
- B. CONTRACTOR: _____
- C. PAYER: Platte County R-III School District
- D. PROJECT: Wilson Auditorium AV Upgrades - Phase 2
- E. ADDRESS: _____

- F. APPLICATION FOR PAYMENT NUMBER: _____
- G. AMOUNT OF FINAL PAYMENT: _____

For and in consideration of the payments made by Owner to the Contractor or to any subcontractor, materialman or supplier of the Contractor, for labor and employed in and/or materials furnished for the construction of the above referenced Project, the Contractor hereby certifies as follows:

1. Upon receipt of the sum specified in Item G. above, the Contractor certifies that it has received payment in full for all sums due and payable under the contract described herein, as amended by all change orders and other amendments, if any (collectively, the "Contract"), and all sums due for all materials furnished to and/or for all Work performed and labor and services furnished in the construction of the Project, and the Contractor hereby affirms that there will be no outstanding claims against the Contractor and/or its sureties in connection with this Project.
2. Contingent upon receipt of the sum specified in item G., the Contractor does hereby waive, release and quit claim in favor of the Owner of the Project, each and every party acquiring title to and/or making a loan on the Project, and the title company or companies examining and/or insuring title to the Project and any and all of their successors and assignees, all rights of the Contractor to assert any lien upon the land and improvements comprising the Project, by virtue of any law in the jurisdiction in which the land and improvements are situate or any amendment of said law, regarding the rights of a contractor, subcontractor, laborer, supplier, or materialman to assert a lien or claim against the Project.
3. Contingent upon receipt of the sum specified in Item G., the Contractor does hereby forever release, waive, and discharge the Project and the Owner of the Project, from any and all causes of action, suits, debts, accounts, damages, liens, encumbrances, judgments, claims, and demands whatsoever, in law or equity which the Contractor and/or its successors and/or assignees ever had, now have, or ever will have against the Owner of the Project, by reason of the Contract and/or the performance of Work and/or the furnishing of labor, services and materials relating to the construction of the Project; and the Contractor hereby agrees to indemnify and hold the above parties harmless from any and all damages, costs, expenses, demands, suits, and legal fees, directly or indirectly relating to or arising out of any claim or lien by any party relating to that which was paid or performed or should have been performed by or for the Contractor in connection with the Project or under the terms of the Contract.
4. The Contractor has not and will not assign any claim against the Owner of the Project, nor any lien or right to perfect a lien against the Project, and the Contractor has the right, power, and authority to execute this Affidavit, Final Waiver and Release.

5. Contingent upon receipt of the sum specified in Item G., the Contractor agrees that all laborers and all subcontractors employed by it, and all other laborers, trade contractors and subcontractors and sub-subcontractors of every tier and all suppliers or materialmen who have furnished Work, labor, materials or services in connection with the Project will be paid in full and that none of such laborers, subcontractors, trade contractors, sub-subcontractors, suppliers, materialmen, or other claimant will have any claim, demand or lien against the Project, and the Contractor hereby agrees to hold the Project and the Owner of the Project harmless from any such claim, demand or lien.

6. No security interest has been given or executed by the Contractor for or in connection with any materials, appliances, machinery, fixtures, or furnishings placed upon or installed in the Project.

This Affidavit, Waiver and Release shall be an independent agreement and covenant and shall operate and be effective with respect to Work and labor done and materials furnished under any supplemental contract or contracts, whether oral or written, for extra or additional work on the Project and for any further work done or materials furnished at any time with respect to the Project subsequent to the execution hereof.

IN WITNESS WHEREOF, this Final Release of Lien has been executed this _____ day of _____, 20____.

WITNESS

	By: _____
	Its: _____

Subscribed and sworn to before me this _____ day of _____, 20____.

(Notary Public)

My Commission Expires: _____

(Notarial Seal)

CONTRACTOR'S PARTIAL WAIVER AND RELEASE OF LIEN

- A. OWNER: Platte County R-III School District
- B. CONTRACTOR: _____
- C. PAYER: Platte County R-III School District
- D. PROJECT: Wilson Auditorium AV Upgrades – Phase 2
- E. ADDRESS: _____

- F. APPLICATION FOR PAYMENT NUMBER: _____
- G. AMOUNT OF PAYMENT: _____

For and in consideration of the payment to be made by Owner to the Contractor in the amount set forth in Item H. above, which payment is for Work, labor and services and/or materials furnished for the construction of the above referenced Project, the Contractor hereby certifies as follows:

- 1. The Contractor hereby waives, releases and quit claims in favor of the Owner of the Project, each and every party acquiring title to and/or making a loan on the Project, and the title company or companies examining and/or insuring title to the Project and any and all of their successors and assignees, all rights of the Contractor to assert a lien upon the land and improvements comprising the Project, but only to the extent of sums actually received for Work, labor, services and materials furnished through _____, plus the sum paid as set forth in item G above.
- 2. The Contractor has not assigned any lien or right to perfect a lien against the Project, and the Contractor has the right, power and authority to execute this document.
- 3. The Contractor warrants that all laborers and all subcontractors employed by the Contractor, and all other laborers, trade contractors and sub-subcontractors of every tier and all suppliers or materialmen who have furnished work, labor, materials or services incorporated into the Project and any lien or bond claimant relating to the Work, labor, materials or services of any such laborers, subcontractors, trade contractors, sub-subcontractors, suppliers or materialmen furnished in connection with the Project, have been paid their respective portion of all prior payments and that none of such laborers, subcontractors, trade contractors, sub-subcontractors, suppliers, materialmen, or other claimants have any claim of lien against the Project through the _____ day of _____, 20____.
- 4. No security interest has been given or executed by the Contractor for or in connection with any materials, appliances, machinery, fixtures, or furnishings placed upon or installed in the Project.

IN WITNESS WHEREOF, this Partial Release of Lien has been executed this _____ day of _____, 20____.

WITNESSES

By: _____
Its: _____

Subscribed and sworn to before me this _____ day of _____, 20____.

(Notary Public)
My Commission Expires: _____

(Notarial Seal)

SECTION 270010 - GENERAL COMMUNICATIONS REQUIREMENTS

PART 1 - GENERAL

1.1 RELATED SECTIONS

- A. Drawings and general provisions of the Contract, including General and Supplementary Conditions and Division 1 Specification Sections, apply to this Section and to all following sections within Division 27.

1.2 SECTION INCLUDES

- A. This Division requires providing complete functioning systems, and each element thereof, as specified, indicated, or reasonably inferred, on the Drawings and in these Specifications, including every article, device, or accessory (whether or not specifically called for by item) reasonably necessary to facilitate each system's functioning as indicated by the design and the equipment specified. Elements of the work include, but are not limited to, materials, labor, supervision, supplies, tools, equipment, transportation and utilities.
- B. Division 27 of these Specifications, and Drawings numbered with prefixes TA, generally describe these systems, but the scope of the Communications Work includes all such Work indicated in all of the Contract Documents, including, but not limited to: Instructions to Bidders; Proposal Form; General Conditions; Supplementary General Conditions; Architectural, Structural, Mechanical, Plumbing, Electrical and Telecommunications Drawings and Specifications; and Addenda.
- C. Drawings are graphic representations of the Work upon which the Contract is based. They show the materials and their relationship to one another, including sizes, shapes, locations, and connections. They also convey the scope of Work, indicating the intended general arrangement of the equipment, fixtures, outlets and cabling without showing all the exact details as to elevations, offsets, and other installation requirements. Use the Drawings as a guide when laying out the Work and to verify that materials and equipment will fit into the designated spaces, and which, when installed per manufacturers' requirements, will ensure a complete, coordinated, satisfactory and properly operating system.
- D. Specifications define the qualitative requirements for products, materials, and workmanship upon which the Contract is based.

1.3 ABBREVIATIONS AND ACRONYMS

- A. ADA Americans with Disabilities Act
- B. AFF Above Finished Floor
- C. AHJ Authority Having Jurisdiction
- D. ANSI American National Standards Institute
- E. ASTM American Society for Testing and Materials
- F. BICS Building Industry Consulting Service International
- G. ETL Electrical Testing Laboratories, Inc.

H.	FCC	Federal Communications Commission
I.	FM	Factory Mutual
J.	GE	Grounding Equalizer
K.	IEEE	Institute of Electrical and Electronic Engineers
L.	LED	Light Emitting Diode
M.	NEC	National Electric Code
N.	NESC	National Electrical Safety Code
O.	NEMA	National Electrical Manufacturers Association
P.	NFPA	National Fire Protection Association
Q.	NRTL	Nationally Recognized Testing Laboratory
R.	OEM	Original Equipment Manufacturer
S.	OFCI	Owner Furnished Contractor Installed
T.	OSHA	Occupational Safety and Health Administration
U.	OSP	Outside Plant
V.	RCDD	Registered Communications Distribution Designer
W.	TBB	Telecommunications Bonding Backbone
X.	TGB	Telecommunications Grounding Bus-bar
Y.	TIA	Telecommunications Industries Association
Z.	TMGB	Telecommunications Main Grounding Bus-bar
AA.	UL	Underwriters Laboratories
BB.	UON or UNO	Unless Otherwise Noted

1.4 DEFINITIONS

- A. Whenever used in these Specifications or Drawings, the following terms shall have the indicated meanings:
1. AHJ - The local code and/or inspection agency (Authority) Having Jurisdiction over the Work.
 2. Approved Equivalents or Equal - For specific products, materials, equipment, or systems for which this Division specifically identifies the Contractor shall use as the basis for their bid. Where the term approved equivalent or equal is listed the contractor may submit documentation for review by the Design Consultant for approval. The Design Consultant's acceptance or rejection is final.
 3. As Directed - means as directed by the Contract Administrator, or his representative.

4. Communications Room - means the location of a floor-serving facility for housing telecommunication equipment, cable terminations, and cross-connect wiring, as well as those for audio video systems and potentially other low-voltage systems such as security and fire alarm (electronic safety and security). This room is recognized in ANSI/TIA-569 as the transition point between the telecommunications horizontal (station) pathway facilities and the backbone (riser) pathway facilities.
5. Concealed - means embedded in masonry or other construction, installed behind wall furring or within drywall partitions, or installed within hung ceilings.
6. Conditionally Approved – the manufacturer has been found reputable by the design professional, but the design professional has not verified that the product offering by manufacturer meets to all specification requirements. Contractor shall adhere to submittal review process for final approval on products.
7. Contract Administrator: Where referenced in this Division, “Contract Administrator” is the primary liaison between the Owner and the Contractor. Specifically, for this project this is “the Architect”.
8. Design Consultant - Where referenced in this Division, “Design Consultant” is the Design Professional for the Work under this Division, and is a Consultant to, and an authorized representative of, the Contract Administrator, as defined in the General and/or Supplementary Conditions. When used in this Division, it means increased involvement by, and obligations to, the Design Professional, in addition to involvement by, and obligations to, the “Contract Administrator”.
9. Furnish - “To supply and deliver to the project site, ready for unloading, unpacking, assembling, installing, and similar operations.”
10. Furnished by Owner (or Owner-Furnished) or Furnished by Others: “An item furnished by the Owner or under other Divisions or Contracts, and installed under the requirements of this Division, complete, and ready for the intended use, including all items and services incidental to the Work necessary for proper installation and operation. Include the installation under the warranty required by this Division.
11. Install - “To perform all operations at the project site, including, but not limited to, and as required: unloading, unpacking, assembling, erecting, placing, anchoring, applying, working to dimension, finishing, curing, protecting, cleaning, testing, commissioning, starting up and similar operations, complete, and ready for the intended use.”
12. NRTL - Nationally Recognized Testing Laboratory, as defined and listed by OSHA in 29 CFR 1910.7 (e.g., UL, ETL, CSA, etc.), and acceptable to the Authority having Jurisdiction (AHJ) over this project. Nationally Recognized Testing Laboratories and standards listed are used only to represent the characteristics required and are not intended to restrict the use of other NRTL’s that are acceptable to the AHJ, and standards that meet the specified criteria.
13. Provide - “To furnish and install complete, and ready for the intended use.”
14. Submit - means submit to Contract Administrator for review.
15. Substitution - means a product meeting all requirements and specifications and having been approved by the Design Consultant to replace another product specifically identified herein.
16. Wet Location - means a pathway that does not protect cables from moisture levels that are beyond the intended operating range of “inside” premises cable.
 - a. For example: Slab-on-grade construction where pathways are installed underground or in concrete slabs that are in direct contact with soil (e.g., sand and gravel) is considered a “wet location.”
 - b. Also refer to the:
 - 1) Telecommunications Distribution Methods Manual (TDMM) for definitions of Wet locations
17. (*) – Where appearing in product part or model numbers; shall represent wild card character to be filled in by the contractor to meet required specifications.

- B. The terms "approved equal", "equivalent", or "equal" are used synonymously and shall mean “accepted by or acceptable to the Design Consultant as equivalent to the item or manufacturer specified”.

- C. The term "approved" shall mean labeled, listed, or both, by an NRTL, and acceptable to the AHJ over this project.

1.5 REFERENCE STANDARDS

- A. Execute all Work in accordance with, and comply at a minimum with, National Fire Protection Association (NFPA) codes, state and local building codes, and all other applicable codes and ordinances in force, governing the particular class of Work involved, for performance, workmanship, equipment, and materials. Additionally, comply with rules and regulations of public utilities and municipal departments affected by connection of services. Where conflicts between various codes, ordinances, rules, and regulations exist, comply with the most stringent. Wherever requirements of these Specifications, Drawings, or both, exceed those of the above items, the requirements of these Specifications, Drawings, or both, shall govern. Code compliance, at a minimum, is mandatory. Construe nothing in these Construction Documents as permitting work not in compliance, at a minimum, with these codes. Bring all conflicts observed between codes, ordinances, rules, regulations and these documents to the Contract Administrator's and Design Consultant's attention in sufficient time, prior to the opening of Bids, to prepare the Supplementary Drawings and Specifications Addenda required to resolve the conflict.
- B. If the conflict is not reported timely, prior to the opening of bids, resolve the conflict and provide the installation in accordance with the governing codes and to the satisfaction of the Contract Administrator and Design Consultant, without additional compensation. Contractor will be held responsible for any violation of the law.
- C. Obtain timely inspections by the constituted authorities having jurisdiction; and, upon final completion of the Work, obtain and deliver to the Owner executed final certificates of acceptance from these authorities having jurisdiction.
- D. All material, manufacturing methods, handling, dimensions, methods of installation and test procedures shall conform to industry standards, acts, and codes, including, but not limited to the following, except where these Drawings and Specifications exceed them.
- E. The references to the following codes, references and standards represent the most current and up-to-date revisions or printing as of the issue of this document including all sections, parts and their addenda. The Contractor is responsible for following the correct revision or printing (UON):
 - 1. ANSI/TIA-569 – "Commercial Building Standard for Telecommunications Pathways and Spaces"
 - 2. NFPA 70 – National Electrical Code (NEC)
 - 3. IEEE National Electrical Safety Code (NESC)
 - 4. Americans with Disabilities Act (ADA) of 1990, as amended

1.6 ADMINISTRATIVE REQUIREMENTS

- A. Coordinate with other Divisions for Communications work to be included but not listed in Division 27 or indicated on Communications Drawings.
- B. Visit the site and ascertain the conditions to be encountered in installing the Work under this Division, verify all dimensions and locations before purchasing equipment or commencing work, and make due provisions for same in the bid. Failure to comply with this requirement shall not be considered justification for omission, alteration, and incorrect or faulty installation of any of the Work under this Division or for additional compensation for any Work covered by this Division.
- C. Refer to Communications Drawings and Divisions of the other trades and to relevant equipment drawings

and shop drawings to determine the extent of clear spaces. Follow these drawings as closely as the actual construction and the work of other trades will permit. Provide all offsets, fittings, and accessories, required to clear equipment, beams and other structural members which may be required but not shown on the Drawings.

- D. Provide materials with trim that will fit properly the types of ceiling, wall, or floor finishes actually installed.
- E. Maintain a project manager, as specified by the Quality Assurance sections of these specifications, on the jobsite at all times to coordinate this Work with other trades so that various components of the Communications systems are installed at the proper time, fits the available space, allows proper service access to all equipment, and meets all required codes and standards.
- F. Carry on the Work in such a manner that the Work of the other trades will not be handicapped, hindered, or delayed at any time.
- G. Work of this Division shall progress according to the "Construction Schedule" as described in Division 01 and as approved by the Contract Administrator. Cooperate in establishing these schedules and perform the Work under this Division, in a timely manner in conformance with the construction schedule so as to ensure successful achievement of all schedule dates.
- H. Carefully check space requirements with other trades to ensure that equipment can be installed in the spaces allotted.
- I. Refer to Coordination requirements in specific sections for additional information.
- J. Examine and compare the Contract Drawings and Specifications with the Drawings and specifications of other trades and report any discrepancies between them to the Contract Administrator and obtain written instructions for changes necessary in the work. Install and coordinate the work in cooperation with other related trades. Before installation, make proper provisions to avoid interferences.
- K. Wherever the work is of sufficient complexity, prepare additional detail drawings to scale to coordinate the work with the work of other trades. Detailed work shall be clearly identified on the Drawings as to the area to which it applies. Submit these drawings to the Contract Administrator for review. At completion include a set of these drawings with each set of Record Drawings.
- L. Before commencing work, examine adjoining work on which this work is in any way affected and report conditions, which prevent performance of the work. Become thoroughly familiar with actual existing conditions to which connections shall be made or which shall be changed or altered.
- M. In cases of doubt as to the work intended, or in the event of need for explanation, request supplementary instructions from the Contract Administrator.

1.7 MEASUREMENTS AND LAYOUTS

- A. The Drawings are schematic in nature but show the various components of the systems approximately to scale and attempt to indicate how they are to be integrated with other parts of the Work. Figured dimensions take precedence to scaled dimensions. Determine exact locations by job measurements, by checking the requirements of other trades, and by reviewing all Contract Documents. Correct, at no additional cost to the Owner, errors that could have been avoided by proper checking and inspection.

1.8 SUBMITTALS

- A. Refer to Division 1 and General Conditions for general submittal requirements. Refer to individual Division 27 Sections for additional submittal requirements. Unless otherwise noted, it is recommended to submit electronically in PDF format.
- B. Submittals and shop drawings shall not contain Henderson Engineers' firm name or logo, nor shall it contain the Engineer of Record's seal and signature. They shall not be photocopies or reproductions of Henderson Engineers' work product. If the contractor desires to use elements of such product, the license agreement for transfer of information at the end of this section shall be used.
- C. Separate submittals according to individual specification sections. Only resubmit those sections requested for resubmittal.
- D. Unless noted otherwise within each individual section, submittals shall be provided for approval in four distinct phases:
 - 1. Pre-bid
 - a. Generally means, UON, submittals required no less than two weeks prior to the due date for the submission of bids, such as:
 - 1) Product substitutions, approved alternate or equivalent requests to be reviewed for approval (Prior to Bid)
 - 2) Alternate personnel credentials to be reviewed for approval
 - 3) And as required by individual sections in this Division
 - 2. Bid
 - a. Generally means, UON, submittals required at the time of the submission of bids, such as:
 - 1) Bid Response Forms
 - 2) Unit Pricing (if required by sections in this Division)
 - 3) Personnel Qualifications
 - 4) Contractor Qualifications (Previous project references)
 - 5) Voluntary Bid Alternates
 - 6) And as required by individual sections in this Division
 - 3. Pre-construction
 - a. Generally means, UON, submittals required after the award of the project to the winning bidder and prior to starting construction.
 - b. Submit the following items no longer than four weeks after receiving the notice to proceed:
 - 1) Division of Labor amongst sub-contractors. Include:
 - a) Company Name
 - b) Address
 - c) Name of project manager for this project, including:
 - i) E-mail
 - ii) Telephone number
 - 2) Construction schedule showing important milestone dates and activities. Schedule shall be coordinated with overall project construction schedule.
 - 3) Updated Personnel and Contractor Qualifications where different from those submitted during the Bid phase.
 - 4) A typed list, indexed by Specification section, of products specifically identified by part number (no wild card characters) within each specification section in this Division. Products are to be listed in the same order as in the specification. List is to include length of manufacturer warranty for each product.
 - 5) Manufacturers' cut-sheets:

- a) Cut-sheets are to be in the same order as in the specification sections.
- b) At a minimum all cut-sheets shall contain the following:
 - i) Cross-reference to the specification section and/or drawings for which the product is to be reviewed for compliance and acceptance
 - ii) Every product cut-sheet submitted for review shall contain the manufacturers' name and logo somewhere on the page
 - iii) All parts, pieces, and equipment submitted for review shall be clearly identified by stamp, markup, or highlight in such a manner that the product(s) being submitted are clearly identifiable and distinguished from all other materials, parts, or equipment that may be on the submittal.
 - iv) For cut-sheets with accessories, additional parts, or derivations of the product being submitted, all shall be clearly identified for the reviewer and acceptance.
 - v) Sufficient detail for reviewer to identify all required information, such as size, weight, color, NRTL listings, approval or certification information, and other necessary identifying information to confirm product meets specifications.
- 6) Samples – refer to individual sections for specific sample requirements.
 - a) Samples requested shall be physical examples that represent materials, equipment or workmanship and establish standards by which the work will be judged. Contractor or Manufacturer shall cover all associated fabrication and shipping costs.
- c. Submit the following items sufficiently prior to installation of each respective portion of work:
 - 1) Shop Drawings
 - a) Shall be furnished per the requirements of each Division 27 specification Section.

4. Project Completion

- a. Generally means, UON, submittals required after the substantial completion but prior to final approval for completion, such as:
 - 1) Record Drawings
 - 2) Operation and Maintenance Data
 - 3) Project test reports
 - 4) Cable Databases (as applicable)
 - 5) Warranty Certificate(s)
 - 6) Lead Installer / Project manager letter with signature stating the project has been installed in accordance with referenced industry standards and contract documents.
 - 7) And as required by individual sections in this Division
- E. Refer to Division 01 for acceptance of electronic submittals for this project. For electronic submittals, Contractor shall submit the documents in accordance with the procedures specified in Division 01. Contractor shall notify the Contract Administrator and Design Consultant that the shop drawings have been posted. If electronic submittal procedures are not defined in Division 1, Contractor shall include the website, user name, and password information needed to access the submittals. For submittals sent by e-mail, Contractor shall copy the Contract Administrator and Design Consultant's designated representatives. Contractor shall allow the Design Consultant review time as specified above in the construction schedule. Contractor shall submit only the documents required to purchase the materials and/or equipment in the electronic submittal and shall clearly indicate the materials, performance criteria and accessories being proposed. General product catalog data not specifically noted to be part of the specified product will be rejected and returned without review.
- F. Identify each sheet of printed submittal pages (using arrows, underlining or circling) to show applicable sizes, types, model numbers, ratings, capacities and options actually being proposed. Cross out non-

applicable information. Note specified features such as materials or paint finish.

- G. Provide submittals in sufficient detail to demonstrate compliance with these Contract Documents and the design concept.
- H. Transmit submittals as early as required to support the project schedule. Allow for two weeks Design Consultant review time, plus to/from mailing time via the Contract Administrator, plus a duplication of this time for resubmittals, if required. Transmit submittals as soon as possible after Notice to Proceed and before construction starts.
- I. No part of the work shall be started in the shop or in the field until the shop drawings and samples for that portion of the work have been submitted and accepted.
- J. Before transmitting submittals and material lists, verify that the equipment submitted is mutually compatible with and suitable for the intended use. Verify that the equipment will fit the available space and allow ample room for maintenance. If the size of equipment furnished makes necessary any change in location, or configuration, submit a shop drawing showing the proposed layout.
- K. The Contractor is not relieved of the responsibility for dimensions or errors that may be contained on submissions, or for deviations from the requirements of the Contract Documents. The noting of some errors but overlooking others does not grant the Contractor permission to proceed in error. Regardless of any information contained in the shop drawings, product data and samples, the Contract Documents govern the work and are neither waived nor superseded in any way by the review of shop drawings, product data and samples.
- L. Submittals shall contain the following information. Submittals not so identified will be returned to the Contractor without action:
 - 1. The project name
 - 2. The applicable Specification Section and paragraph
 - 3. The submittal date
 - 4. The submitting (sub-)contractor's company name and the project manager's name and contact information.
- M. Include dimensional data for roughing in and installation and technical data sufficient to verify that equipment meets the requirements of the Contract Documents. Include wiring, piping and service connection data.
- N. The Design Consultant's checking and subsequent acceptance of such submittals shall not relieve the Contractor from responsibility for deviations from Drawings or Specifications unless he has, in writing, called the Design Consultant's and Contract Administrator's attention to such deviations at the time of submission, and secured written acceptance; nor shall it relieve the Contractor from responsibility for errors in dimensions, details, sizes of members, or quantities; or for omissions of components or fittings; or for not coordinating items with actual building conditions and adjacent work.
- O. The work described in shop drawing submissions shall be carefully checked by all trades for clearances (including those required for maintenance and servicing), field conditions, maintenance of architectural conditions and coordination with other trades on the job. Each submitted shop drawing shall include a certification that related job conditions have been checked by the Contractor and each Subcontractor and that conflicts do not exist.
- P. Maintain a complete set of reviewed and stamped shop drawings and product data on site.
- Q. Inadequate or incomplete shop drawings, product data and/or samples will not be reviewed and will be returned to the Contractor for resubmittal.

1.9 SUBSTITUTIONS

- A. Refer to Division 1 and General Conditions for substitutions in addition to requirements specified herein.
- B. Materials, products, equipment, and systems described in the Bidding Documents establish a standard of required function, dimension, appearance and quality to be met by the proposed substitution.
- C. The base bid shall include only the products from manufacturers specifically named in the drawings and specifications.
- D. Request for Substitution:
 - 1. Complete and send the Substitution Request Form attached at the end of this section for each material, product, equipment, or system that is proposed to be substituted.
 - 2. The burden of proof of the merit of the proposed substitution is upon the proposer.
 - 3. Unless stated otherwise in writing to the Engineer by the Contractor, Contractor warrants to the Engineer, Contract Administrator, and Owner the following:
 - a. Proposed substitution has been fully investigated and determined to meet or exceed the specified Work in all respects.
 - b. Proposed substitution is consistent with the Contract Documents and will produce indicated results, including functional clearances, maintenance service, and sourcing of replacement parts.
 - c. Proposed substitution has received necessary approvals of the Authorities Having Jurisdiction.
 - d. Same warranty will be furnished for proposed substitution as for specified Work.
 - e. If accepted substitution fails to perform as required, Contractor shall replace substitute material or system with that originally specified and bear costs incurred thereby.
 - f. Coordination, installation and changes in the Work as necessary for accepted substitution will be complete in all respects.
- E. Substitution Consideration:
 - 1. No substitutions will be considered unless the Substitution Request Form is completed and attached with the appropriate substitution documentation.
 - 2. No substitutions will be considered prior to receipt of bids unless written request for approval to bid has been received by the Engineer at least ten (10) calendar days prior to the date for receipt of bids.
 - 3. If the proposed substitution is approved prior to receipt of bids, such approval will be stated in an addendum. Bidders shall not rely upon approvals made in any other manner. Verbal approval will not be given.
 - 4. No substitutions will be considered after the Contract is awarded unless specifically provided in the Contract Documents.

1.10 ELECTRONIC DRAWING FILES

- A. In preparation of shop drawings or record drawings, Contractor may, at their option, obtain electronic drawing files in AutoCAD or DXF format from the Engineer.
- B. Contractor shall request and complete the Electronic File Release Agreement form from the Engineer. Send the form along with a check made payable to Henderson Engineers, Inc. Contractor shall indicate the desired shipping method and drawing format on the attached form.
- C. Contact the Contract Administrator for written authorization.

- D. The following must be received before electronic drawing files will be sent:
 - 1. Contract Administrator's written authorization
 - 2. Engineer's release agreement form
 - 3. Payment

1.11 QUALITY ASSURANCE

- A. Execute all work under this Division in a thorough and professional manner by competent and experienced workmen duly trained to perform the work specified.
- B. Install all work in strict conformance with all manufacturers' requirements and recommendations, unless these Documents exceed those requirements. Install all equipment and materials in a neat and professional manner, aligned, leveled, and adjusted for satisfactory operation, in accordance with NECA guidelines.
- C. Unless indicated otherwise on the Drawings, provide all material and equipment new, of the best quality and design, free from defects and imperfections and with markings or a nameplate identifying the manufacturer and providing sufficient reference to establish quality, size and capacity. Provide all material and equipment of the same type from the same manufacturer whenever practicable.
- D. Unless specified otherwise, manufactured items of the same types specified within this Division shall have been installed and used, without modification, renovation, or repair for not less than one year prior to date of bidding for this Project.

1.12 OPERATION AND MAINTENANCE MANUALS

- A. Refer to Division 1 and General Conditions for Operation and Maintenance Manuals in addition to requirements specified herein.
- B. Submit manuals prior to requesting the final punch list and before all requests for Substantial Completion.
- C. Instruct the Owner's permanent personnel in the proper operation of, startup and shutdown procedures and maintenance of the equipment and components of the systems installed under this Division.
- D. Prior to Substantial Completion of the project, furnish to the Contract Administrator, for Engineer's review, and for the Owner's use, four (4) copies of Operation and Maintenance Manuals in labeled, hard-back three-ring binders, with cover, binding label, tabbed dividers and plastic insert folders for Record Drawings. Include local contacts, complete with address and telephone number, for equipment, apparatus, and system components furnished and installed under this Division of the specifications.
- E. Each manual shall contain equipment data, approved submittals, shop drawings, diagrams, capacities, spare part numbers, manufacturer service and maintenance data, warranties and guarantees.
- F. Refer to Division 1 for acceptance of electronic manuals for this project. For electronic manuals, Contractor shall submit the documents in accordance with this Section and the procedures specified in Division 1. Contractor shall notify the Contract Administrator and Engineer that the manuals have been posted. If electronic manual procedures are not defined in Division 1, Contractor shall include the website, user name and password information needed to access the manuals. For manuals sent by e-mail, Contractor shall copy the Contract Administrator's and Engineer's designated representatives.

1.13 SPARE PARTS

- A. Provide to the Owner the spare parts specified in the individual sections of this Division.

1.14 RECORD DRAWINGS

- A. Refer to Division 01 and General Conditions for Record Drawings in addition to requirements specified herein.
- B. A set of work prints of the Contract Documents shall be kept on the jobsite during construction for the purpose of noting changes. During the course of construction, the Contractor shall indicate on these Documents changes made from the original Contract Documents. Particular attention shall be paid to those items which need to be located for servicing. Underground utilities shall be located by dimension from column lines.
- C. At the completion of the project, the Contractor shall obtain, at their expense, reproducible copies of the final drawings and incorporate changes noted on the jobsite work prints onto these drawings. These changes shall be done by a skilled drafter. Each sheet shall be marked "Record Drawing", along with the date. These drawings shall be delivered to the Contract Administrator.

1.15 DELIVERY, STORAGE AND HANDLING

- A. Refer to Division 01 and General Conditions for Delivery, Storage and Handling in addition to requirements specified herein.
- B. Deliver equipment and material to the job site in their original containers with labels intact, fully identified with manufacturer's name, make, model, model number, type, size, capacity and Underwriter's Laboratories, Inc. labels and other pertinent information necessary to identify the item.
- C. Deliver, receive, handle and store equipment and materials at the job site in the designated area and in such a manner as to prevent equipment and materials from damage and loss. Store equipment and materials delivered to the site on pallets and cover with waterproof, tear resistant tarp or plastic or as required to keep equipment and materials dry. Follow manufacturer's recommendations, and at all times, take every precaution to properly protect equipment and material from damage, including the erection of temporary shelters to adequately protect equipment and material stored at the Site. Equipment and/or material which becomes rusted or damaged shall be replaced or restored by the Contractor to a condition acceptable to the Contract Administrator.
- D. Be responsible for the safe storage of tools, material and equipment.

1.16 WARRANTIES

- A. Refer to Division 01 and General Conditions for Warranties in addition to requirements specified herein.
- B. Organize warranty documents into an orderly sequence based on the table of contents of the Project Manual.
- C. Warrant each system and each element thereof against all defects due to faulty workmanship, design or material for a period of 12 months from date of Substantial Completion, unless specific items are noted to carry a longer warranty in these Construction Documents or manufacturer's standard warranty exceeds 12 months. Remedy all defects, occurring within the warranty period(s), as stated in the General Conditions and Division 01.

- D. The above warranties shall include labor and material. Make repairs or replacements without any additional costs to the Owner.
- E. Perform the remedial work promptly, upon written notice from the Contract Administrator or Owner.
- F. At the time of Substantial Completion, deliver to the Owner all warranties, in writing and properly executed, including term limits for warranties extending beyond the one year period, each warranty instrument being addressed to the Owner and stating the commencement date and term.

1.17 TEMPORARY FACILITIES

- A. Refer to Division 1 and General Conditions for Temporary Facilities requirements.
- B. Temporary Utilities: The types of services required include, but are not limited to, electricity, telephone, and internet. When connecting to existing franchised utilities for required services, comply with service companies' recommendations on materials and methods, or engage service companies to install services. Locate and relocate services (as necessary) to minimize interference with construction operations.

1.18 FIELD CONDITIONS

- A. Conditions Affecting Work In Existing Buildings: The following project conditions apply:
 - 1. The Drawings describe the general nature of remodeling to the existing building; however, visit the Site prior to submitting bid to determine the nature and extent of work involved.
 - 2. Schedule Work in the existing building with the Owner.
 - 3. Perform certain demolition work prior to the remodeling. Perform the demolition that involves Communications systems, equipment, raceways, equipment supports or foundations and materials.
 - 4. Remove articles that are not required for the new Work. Unless otherwise indicated, remove each item removed during this demolition from the premises and dispose in accordance with applicable federal, state and local regulations.
 - 5. Relocate and reconnect Communications facilities that shall be relocated to accomplish the remodeling shown in the Drawings or indicated in the Specifications. Where communications equipment or materials are removed, cap unused raceways below the floor line or behind the wall line to facilitate restoration of finish.
 - 6. Obtain permission from the Contract Administrator for channeling of floors or walls not specifically noted on the Drawings.
 - 7. Protect adjacent materials indicated to remain. For Work specific to this Division, install and maintain dust and noise barriers to keep dirt, dust, and noise from being transmitted to adjacent areas. Remove protection and barriers after demolition operations are complete.
 - 8. Locate, identify, and protect Communications services passing through demolition area and serving other areas outside the demolition limits. Maintain services to areas outside demolition limits. When services shall be interrupted, provide temporary services for affected areas.
- B. Conditions Affecting Excavations: The following project conditions apply:
 - 1. Maintain and protect existing building services that transit the area affected by selective demolition.
 - 2. Protect structures, utilities, sidewalks, pavements, and other facilities from damage caused by settlement, lateral movement, undermining, washout, and other hazards created by excavation operations.
- C. Site Information: Subsurface conditions were investigated during the design of the Project. Reports of these investigations are available for information only; data in the reports are not intended as

representations or warranties of accuracy or continuity of conditions. The Owner will not be responsible for interpretations or conclusions drawn from this information.

- D. Use of explosives is not permitted.
- E. Environmental Conditions: Apply joint sealers under temperature and humidity conditions within the limits specified by the joint sealer manufacturer. Do not apply joint sealers to wet substrates.

PART 2 - PRODUCTS

2.1 NOT USED

PART 3 - EXECUTION

3.1 INSTALLATION, GENERAL

- A. Install in accordance with manufacturer's instructions.

3.2 EXISTING CONDITIONS

- A. Existing conditions indicated on the Drawings are taken from the best information available from the Owner, existing record drawings, and from limited, in-situ, visual site observations; and, they are not to be construed as "AS BUILT" conditions. The information is shown to help establish the extent of the new Work.
- B. Verify all actual existing conditions at the project site and perform the Work as required to meet the existing conditions and the intent of the Work indicated.

3.3 EXISTING UTILITIES

- A. Existing utility services not specifically indicated to be removed or altered shall remain as they presently exist.
- B. Where existing services interfere with demolition or construction, alter or reroute such existing equipment to facilitate demolition or construction after obtaining written permission from the Contract Administrator. Notify in writing giving two weeks advance notice or planned alteration prior to altering any existing condition is required.
- C. Schedule and coordinate with the utility company, Owner and with the Contract Administrator all connections to, relocation of, or discontinuation of normal services from any existing service provider line. Include all premium time required for all such work in the Bid.
- D. Preserve continuity of service of existing facilities (related to damage or alteration due to new construction). Unauthorized alteration to existing equipment shall be corrected without additional cost to the Owner.
- E. Repair all existing utilities damaged due to construction operations to the satisfaction of the Owner or Utility Company without additional cost.
- F. Do not leave utilities disconnected at the end of a workday or over a weekend unless authorized by

representatives of the Owner or Contract Administrator.

- G. Make repairs and restoration of utilities before workmen leave the project at the end of the workday in which the interruption takes place.
- H. Include in Bid the cost of furnishing temporary facilities to provide all services during interruption of normal utility service.

3.4 WORK IN EXISTING FACILITIES

- A. The Drawings describe the general nature of remodeling to the existing facilities; however, visit the Site prior to submitting a Bid, to determine the nature and extent of Work involved.
- B. Schedule Work in the existing facility with the Owner.
- C. Certain demolition work shall be performed prior to the remodeling. Perform the demolition that involves communications systems, conduit, wiring, equipment, equipment supports or foundations and materials.
- D. Remove all of these articles that are not required for the new Work. Unless otherwise indicated, each item removed during this demolition shall be removed from the premises and disposed of in accordance with all state and local regulations.
- E. Interruption of Existing Communications Service: Do not interrupt communication service to facilities occupied by Owner or others unless permitted under the following conditions and then only after arranging to provide temporary communication service according to requirements indicated:
 - 1. Notify Contract Administrator and the Owner no fewer than 7 days in advance of proposed interruption of communication service.
 - 2. Do not proceed with interruption of communication service without Contract Administrator and the Owner's written permission.
 - 3. Owner reserves the right to require Contractor to cease work in any area Owner requires access to on an emergency basis.
- F. Reconnect communication circuits serving equipment required to remain in service to other cable termination fields, patch panels or splices as indicated on the Drawings or as appropriate. Provide additional cable and termination hardware where there is insufficient available capacity in remaining existing equipment for reconnection.
- G. Relocate and reconnect all communications facilities that must be relocated in order to accomplish the remodeling shown in the Drawings or indicated in the Specifications. Where communications devices or equipment are removed, cap all unused raceways behind the floor line or wall line to facilitate restoration of finish, and, remove all existing wiring from abandoned raceways.
- H. Finish materials are specified in other divisions.
- I. Where removal of existing wiring interrupts continuity of communication circuits that are to remain in use, provide necessary wiring, raceways, junction boxes, etc., to ensure continued communication continuity.
- J. Channel walls and floors as required to produce the desired result; however, obtain permission from the Contract Administrator for all channeling not specifically noted on the Drawings.

3.5 PERMITS AND FEES

- A. Secure and Pay all required fees and obtain all required permits related to the Communications Infrastructure installation.
- B. Pay royalties or fees in connection with the use of patented devices and systems.

3.6 SELECTIVE DEMOLITION

- A. Refer to Division 01, Division 02, and General Conditions for Selective Demolition requirements.
- B. General: Demolish, remove, demount, and disconnect abandoned communications materials and equipment indicated to be removed and not indicated to be salvaged or saved.
- C. Materials and Equipment to Be Salvaged:
 - 1. Communications Infrastructure equipment to be removed that is in good working order shall be carefully removed and offered to the Owner. Items rejected by the Owner shall be removed from the project site and legally and properly disposed of.
 - 2. Remove, demount, and disconnect existing communications materials and equipment indicated to be removed and salvaged, and deliver materials and equipment to the location designated for storage.
- D. Remove existing conduit and wire back to the Communications Equipment room, unless a specific extent of removal is indicated on the Drawings.
- E. Communications Materials and Equipment: Demolish, remove, demount, and disconnect the following items:
 - 1. Inactive and obsolete raceways, fittings, supports and specialties, equipment, wiring, controls, fixtures, and insulation:
 - a. Raceways and outlets embedded in floors, walls, and ceilings may remain if such materials do not interfere with new installations. Cut embedded raceways to below finished surfaces, seal, and refinish surfaces as specified or as indicated on the Architectural Finish Drawings. Remove materials above accessible ceilings. Cap raceways allowed to remain.
 - b. Perform cutting and patching required for demolition in accordance with Division 01, General Conditions and “Cutting and Patching” portion of this Section in Division 27.

3.7 ACCESS TO EQUIPMENT

- A. Locate all pull boxes, junction boxes and controls so as to provide easy access for operation, service inspection and maintenance. Provide an access door where equipment or devices are located above inaccessible ceilings. Refer to Division 26 Section “Common Work Results for Electrical”.
- B. Maintain all code required clearances and clearances required by manufacturers.

3.8 PENETRATIONS

- A. Unless otherwise noted as being provided under other divisions, provide sleeves, box frames, or both, for openings in floors, walls, partitions and ceilings for all electrical work that passes through construction. Refer to Division 27 Section “Common Work Results for Communications”.
- B. Provide sleeves, box frames, or both, for all conduit, cable, and cable trays that pass through masonry,

concrete or block walls.

- C. The cutting of new and/or existing construction will not be permitted except by written approval of the Contract Administrator.

3.9 EXCAVATION AND BACKFILLING

- A. Refer to Division 01, Division 02 and General Conditions for Excavation and Backfilling in addition to the requirements specified herein.
- B. Perform excavation of every description, of whatever substance encountered and to the depth required in connection with the installation of the work under this division. Excavation shall be in conformance with applicable Divisions and sections of the Specifications.
- C. Restore roads, alleys, streets and sidewalks damaged during this work to the satisfaction of Authorities Having Jurisdiction.
- D. Do not excavate trenches close to walks or columns without prior consultation with the Contract Administrator.
- E. Erect barricades around excavations, for safety, and place an adequate number of amber lights on or near the work and keep those burning from dusk to dawn. Be responsible for all damage that any parties may sustain in consequence of neglecting the necessary precautions in prosecuting the work.
- F. Slope sides of excavations to comply with local, state and federal codes and ordinances. Shore and brace as required for stability of excavation.
- G. Shoring and Bracing: Establish requirements for trench shoring and bracing to comply with local, state and federal codes and authorities. Maintain shoring and bracing in excavations regardless of time period excavations will be open.
 - 1. Remove shoring and bracing when no longer required. Where sheeting is allowed to remain, cut top of sheeting at an elevation of 30 inches below finished grade elevation.
- H. Install sediment and erosion control measures in accordance with local codes and ordinances.
- I. Dewatering: Prevent surface water and subsurface or ground water from flowing into excavations and from flooding project site and surrounding area.
 - 1. Do not allow water to accumulate in excavations. Remove water to prevent softening of bearing materials. Provide and maintain dewatering system components necessary to convey water away from excavations.
 - 2. Establish and maintain temporary drainage ditches and other diversions outside excavation limits to convey surface water to collecting or run-off areas. Do not use trench excavations as temporary drainage ditches. In no case shall sewers be used as drains for such water.
- J. Material Storage: Stockpile satisfactory excavated materials where directed, until required for backfill or fill. Place, grade, and shape stockpiles for proper drainage.
 - 1. Locate and retain soil materials away from edge of excavations. Do not store within drip-line of trees indicated to remain.
 - 2. Remove and legally dispose of excess excavated materials and materials not acceptable for use as backfill or fill.

- K. Excavation for Underground Structures: Conform to elevations and dimensions shown within a tolerance of plus or minus 0.10 foot; plus, a sufficient distance to permit placing and removal of concrete formwork, installation of services, other construction, and for inspection.
1. Excavate, by hand, areas within drip-line of large trees. Protect the root system from damage and dry-out. Maintain moist conditions for root system and cover exposed roots with burlap. Paint root cuts of one inch in diameter and larger with emulsified asphalt tree paint.
 2. Take care not to disturb bottom of excavation. Excavate by hand to final grade just before concrete reinforcement is placed.
- L. Trenching: Excavate trenches for electrical installations as follows:
1. Excavate trenches to the uniform width, sufficiently wide to provide ample working room and a minimum of six to nine inches clearance on both sides of raceway and cables.
 2. Excavate trenches to depth indicated or required for raceway and cables to establish slope, away from buildings and indicated elevations. Beyond building perimeter, excavate trenches to an elevation below frost line.
 3. Limit the length of open trench to that in which raceway and cables can be installed, tested, and the trench backfilled within the same day.
 4. Where rock is encountered, carry excavation below required elevation and backfill with a layer of crushed stone or gravel prior to installation of raceway and cables. Provide a minimum of six inches of stone or gravel cushion between rock bearing surface and raceway and cables.
 5. Excavate trenches for raceway, cables, and equipment with bottoms of trench to accurate elevations for support of raceway and cables on undisturbed soil.
- M. Cold Weather Protection: Protect excavation bottoms against freezing when atmospheric temperature is less than 35 degrees F.
- N. Backfilling and Filling: Place soil materials in layers to required subgrade elevations for each area classification listed below, using materials specified in Part 2 of this Section.
1. Under walks and pavements, use a combination of subbase materials and excavated or borrowed materials.
 2. Under building slabs, use drainage fill materials.
 3. Under raceway and cables, use subbase materials where required over rock bearing surface and for correction of unauthorized excavation.
 4. For raceway and cables less than 30 inches below surface of roadways, provide 4-inch-thick concrete base slab support. After installation and testing of raceway and cables, provide a 4-inch thick concrete encasement (sides and top) prior to backfilling and placement of roadway subbase.
 5. Other areas use excavated or borrowed materials.
- O. Backfill excavations as promptly as work permits, but not until completion of the following:
1. Inspection, testing, approval, and locations of underground utilities have been recorded.
 2. Removal of concrete formwork.
 3. Removal of shoring and bracing, and backfilling of voids.
 4. Removal of trash and debris.
- P. Placement and Compaction: Place backfill and fill materials in layers of not more than 8 inches in loose depth for material compacted by heavy equipment, and not more than 4 inches in loose depth for material compacted by hand-operated tampers.
1. For vertical and diagonal raceway installations, thoroughly support raceways from permanent structures or undisturbed earth at no less than 10-foot intervals, while placing backfill materials, so that raceways are not deflected, crushed, broken, or otherwise damaged by the backfill placement.

- Q. Before compaction, moisten or aerate each layer as necessary to provide optimum moisture content. Compact each layer to required percentage of maximum dry density or relative dry density for each area classification specified below. Do not place backfill or fill material on surfaces that are muddy, frozen, or contain frost or ice.
- R. Place backfill and fill materials evenly adjacent to structures, piping, and equipment to required elevations. Prevent displacement of raceways and equipment by carrying material uniformly around them to approximately same elevation in each lift.
- S. Compaction: Control soil compaction during construction, providing minimum percentage of density specified for each area classification indicated below:
 - 1. Percentage of Maximum Density Requirements: Compact soil to not less than the following percentages of maximum density for soils which exhibit a well-defined moisture-density relationship (cohesive soils), determined in accordance with ASTM D 1557 and not less than the following percentages of relative density, determined in accordance with ASTM D 2049, for soils which will not exhibit a well-defined moisture-density relationship (cohesionless soils).
 - a. Areas Under Structures, Building Slabs and Steps, Pavements: Compact top 12 inches of subgrade and each layer of backfill or fill material to 90 percent maximum density for cohesive material, or 95 percent relative density for cohesionless material.
 - b. Areas Under Walkways: Compact top 6 inches of subgrade and each layer of backfill or fill material to 90 percent maximum density for cohesive material, or 95 percent relative density for cohesionless material.
 - c. Other Areas: Compact top 6 inches of subgrade and each layer of backfill or fill material to 85 percent maximum density for cohesive soils, and 90 percent relative density for cohesionless soils.
 - 2. Moisture Control: Where subgrade or layer of soil material must be moisture conditioned before compaction, uniformly apply water. Apply water in minimum quantity necessary to achieve required moisture content and to prevent water appearing on surface during, or subsequent to, compaction operations.
- T. Subsidence: Where subsidence occurs at mechanical installation excavations during the period 12 months after Substantial Completion, remove surface treatment (i.e., pavement, lawn, or other finish), add backfill material, compact to specified conditions, and replace surface treatment. Restore appearance, quality, and condition of surface or finish to match adjacent areas.

3.10 CUTTING AND PATCHING

- A. Cut walls, floors, ceilings, and other portions of the facility as required to install work under this Division.
- B. Obtain permission from the Architect prior to cutting. Do not cut or disturb structural members without prior approval from the Architect and Structural Engineer.
- C. For post-tension slabs, x-ray slab and closely coordinate all core drill locations with Architect and Structural Engineer prior to performing any work. Obtain approval from Architect and Structural Engineer for all core drills and penetrations at least four days prior to performing work.
- D. Penetrations shall be made as small as possible while maintaining required clearances between the building element penetrated and the system component.
- E. Patch around openings to match adjacent construction, including fire ratings, if applicable.

- F. Repair and refinish areas disturbed by work to the condition of adjoining surfaces in a manner satisfactory to the Architect.

3.11 PAINTING

- A. Refer to Division 09 Section "Painting" for painting requirements.
- B. Paint exposed ferrous surfaces, including, but not limited to, hangers, equipment stands and supports using materials and methods as specified under individual sections and Division 09 of the Specifications; colors shall be as selected by the Contract Administrator.
- C. Re-finish all field-threaded ends of galvanized conduits and field-cut ends of galvanized supports with a cold-galvanizing compound approved for use on conductive surfaces. Follow closely manufacturer's instructions for pre-cleaning surfaces and application.
- D. Factory finishes, and shop priming and special finishes are specified in the individual equipment Specification sections.
- E. Where factory finishes are provided, and no additional field painting is specified, touch up or refinish, as required by, and to the acceptance of, the Contract Administrator, marred or damaged surfaces so as to leave a smooth, uniform finish. If, in the opinion of the Contract Administrator, the finish is too badly damaged to be properly re-finished, replace the damaged equipment or materials at no additional costs to the Owner.

3.12 CLEANING

- A. Remove dirt and refuse, resulting from the performance of the Work, from the premises as required to prevent accumulation. Cooperate in maintaining reasonably clean premises at all times.
- B. Immediately prior to final inspection, make a final cleanup of dirt and refuse resulting from Work and assist in making the premises vacuum clean. Clean all material and equipment installed under this Division.
- C. Remove dirt, dust, plaster, stains, and foreign matter from all surfaces.
- D. Touch up and restore damaged finishes to their original condition.
- E. All communications equipment shall be thoroughly vacuumed and wiped clean prior to startup and at the completion of the project. Equipment shall be opened for observation as required.

3.13 ADJUSTING, ALIGNING AND TESTING

- A. Adjust, align and test all equipment furnished and/or installed under this Division.
- B. Check and test protective devices for specified and required application and adjust as required.
- C. Verify that completed wiring system is free from short circuits, unintentional grounds, low insulation impedances, and unintentional open circuits.
- D. Notify the Contract Administrator immediately of all operational failures caused by defective material, labor or both.

- E. Refer to individual Sections for additional and specific requirements.

3.14 START-UP OF SYSTEMS

- A. Prior to start-up of each system, check all components and devices to confirm compliance with manufacturers' recommended installation procedures.
- B. Demonstrate that all equipment and systems perform properly as designed per Drawings and Specifications.
- C. Refer to individual Sections for additional and specific requirements.

3.15 SUBSTANTIAL COMPLETION REVIEW

- A. Prior to requesting a site observation for "CERTIFICATION OF SUBSTANTIAL COMPLETION", complete the following items:
 - 1. Submit results of systems tests and adjustments per each individual section.
 - 2. Submit complete Operation and Maintenance Data.
 - 3. Submit complete Record Drawings.
 - 4. Perform all required training of Owner's personnel.
 - 5. Turn over all spares and extra materials to the Owner, along with a complete inventory of spares and extra materials being turned over.
 - 6. Perform start-up tests of all systems.
 - 7. Remove all temporary facilities from the site.
 - 8. Comply with all requirements for Substantial Completion in the Division 1 and General Conditions.
- B. Request in writing a review for Substantial Completion and scheduling of final acceptance. Provide a minimum of five (5) business days' notice prior to the review for project sites within a 4-hour drive from the office where the design was created; provide a minimum of eight (8) business days' notice for sites beyond a 4-hour drive.
- C. State in the written request that the Contractor has complied with the requirements for Substantial Completion.
- D. Upon receipt of a request for review, the Contract Administrator will either proceed with the review or advise the Contractor of unfilled requirements.
- E. If the Contractor requests a site visit for Substantial Completion review prior to completing the above-mentioned items, then provide reimbursement to the Contract Administrator and Design Consultant for time and expenses incurred for the visit.
- F. Upon completion of the review, the Contract Administrator and Design Consultant will prepare a "final list" of outstanding items to be completed or corrected for final acceptance.
- G. Omissions on the "final list" shall not relieve the Contractor from the requirements of the Contract Documents.
- H. Prior to requesting a final review, submit a copy of the final list of items to be completed or corrected. State in writing that each item has been completed, resolved for acceptance or the reason it has not been completed.

3.16 EARLY OCCUPANCY

- A. Failure to meet the Substantial Completion date can result in the Owner needing to take early occupancy. Complete the systems which are necessary to allow partial early occupancy of the building by original Substantial Completion date.
 - 1. Refer to individual sections for additional requirements.
- B. Verify and comply with requirements for temporary occupancy with the local Building and Fire Departments.

END OF SECTION 270010

SECTION 270500 - COMMON WORK RESULTS FOR COMMUNICATIONS

PART 1 - GENERAL REQUIREMENTS

1.1 SECTION INCLUDES

- A. This Section includes general construction materials and methods, communications equipment coordination, and common communications installation requirements for Division 27 systems as follows:
 - 1. Grounding and Bonding for Communications
 - 2. Pathways for communications systems.
 - a. Cable Hook Systems
 - b. Conduit
 - c. Surface Raceways
 - d. Outlet Boxes
 - e. Floor Boxes and Poke Throughs
 - f. Pull Boxes
 - g. Cable Tray
 - 3. Firestopping Systems
 - 4. Access Panels
 - 5. Identification

1.2 RELATED REQUIREMENTS

- A. Except as modified by governing codes and by the Contract Documents, comply with the applicable provisions and recommendations in the following Sections: 27 Section “General Communications Requirements”
- B. Division 27 “General Communications Requirements”

1.3 DEFINITIONS

- A. AV – Audio Video
- B. Cable Tray System – A unit or assembly of units or sections and associated fittings forming a structural system used to securely fasten or support cables and raceways.
- C. Common Work – all Work specified in this section.
- D. Conduit Body – A separate portion of a conduit or tubing system that provides access through a removeable cover(s) to the interior of the system at a junction of two or more sections of the system or at a terminal point of the system. Boxes such as FS and FD or larger cast or sheet metal boxes are not classified as conduit bodies.
- E. Conveniently Accessible – Capable of being reached from the floor or via the use of an 8 foot step ladder without crawling or climbing over or under obstacles such as piping, duct work, motors, transformers, pumps, etc.

- F. Firestopping System – Firestopping products that have been specifically tested and rated by a Nationally Recognized Testing Laboratory (NRTL), such as UL, to provide the required flame (F), fire and temperature (T), air and smoke (L), and water (W) containment for a given partition/penetration.
 - G. Floor Box Assembly (Floor Box) – An on-grade solution or above grade (with a native fire classification or in combination with an approved Firestopping System) solution for in-floor terminations. The Assembly consists of pour pan (as applicable), Firestopping System (as applicable), floor box (compartment), plate mounting brackets, line voltage divider plates, termination plates, termination connectors, electrical receptacle(s), gang plates (termination cover plates), and access door / cover / lid.
 - H. Ground or Grounding – A conducting connection, whether intentional or accidental, between an electrical circuit (e.g. telecommunications) or equipment and the earth, or to some conducting body that serves in place of earth.
 - I. IMC – Intermediate Metal Conduit
 - J. Plenum – A compartment or chamber to which one or more air ducts are connected and that forms part of the air distribution system.
 - K. Plenum-rated – A product that is listed by a NRTL as being suitable for installation into a plenum space.
 - L. Point of Entrance (Building Entrance) – The point within a building where the Outside Plant (OSP) communications cabling emerges from an external wall, a concrete floor slab, or IMC/RMC. If Communications Point of Entrance isn't identified on the drawings, assume the Main Communications (MDF) also acts as the Point of Entrance.
 - M. Poke Through Assembly (Poke-Thru) – An above grade solution with a native fire classification for in-floor terminations. The Assembly consists of pre-pour sleeve (as applicable), Firestopping System, fire resistant conduit stub, poke thru (compartment), plate mounting brackets, line voltage divider plates, termination plates, termination connectors, electrical receptacle(s), gang plates (termination cover plates, as applicable), and access door / cover / lid.
 - N. Quality Control Specialist – as it pertains to Work within this section, Quality Control Specialist is the Project AVIXA CTS-I, as defined in Division 27 Section “Audio Video Systems”, for Common Work for AV.
 - O. RMC – Rigid Metal Conduit
 - P. Surface Metal Raceway – A metallic raceway that is intended to be mounted to the surface of a structure, with associated couplings, connectors, boxes, and fittings for the installation of electrical conductors.
 - Q. Surface Nonmetallic Raceway – A nonmetallic raceway that is intended to be mounted to the surface of a structure, with associated couplings, connectors, boxes, and fittings for the installation of electrical conductors.
 - R. UL – Underwriters Laboratory
- 1.4 REFERENCE STANDARDS
- A. Follow all applicable codes, references, guidelines, and standards listed in Division 27 Section “General Communications Requirements”.
 - B. Follow the additional codes, references, standards and guidelines:

1. NEMA VE 1-1998 – “Metallic Cable Tray Systems”
2. NEMA VE 2-2000 – “Cable Tray Installation Guidelines”
3. ASTM E 814 and ANSI/UL1479 –“Fire Tests Through Penetration Firestops”
4. ASTM E 84 and ANSI/UL 723 “Surface Burning Characteristics of Building Materials”
5. ASTM E 119 and ANSI/UL 263 “Fire Tests of Building Construction Materials”

1.5 ADMINISTRATIVE REQUIREMENTS

- A. Adjust location of conduits, terminal blocks, equipment, etc., to accommodate the work to prevent interferences, both anticipated and encountered. Determine the exact route and location of each conduit prior to fabrication:
 1. Right-of-Way: Lines which pitch shall have the right-of-way over those which do not pitch. For example: condensate, steam, and plumbing drains normally have right-of-way. Lines whose elevations cannot be changed have right-of-way over lines whose elevations can be changed.
 2. Provide offsets, transitions and changes in direction of conduit as required to maintain proper headroom and pitch on sloping lines.
 3. So connecting raceways, cables, and wireways will be clear of obstructions and of the working and access space of other equipment.
- B. Coordinate installation of required supporting devices and set sleeves in cast-in-place concrete, masonry walls, and other structural components as they are constructed.
- C. Coordinate location of access panels and doors for communications items that are behind finished surfaces or otherwise concealed.

1.6 SUBMITTALS

- A. Follow the requirements for submittals in Division 27 Section “General Communications Requirements”.
- B. ”Bid” Phase
 1. Contractor Qualifications for Firestopping Systems: Provide copies of training/certification as required in the Quality Assurance portion of this specification section.
- C. “Pre-construction” Phase
 1. Manufacturers’ cut sheets or catalog cut sheets of each of the pathways not specifically identified by its exact part number:
 - a. In addition to Division 27 Section “General Communications Requirements”, include the following:
 - 1) Size – including physical and loading dimensions
 - 2) Maximum span length
 - 3) Weight supported
 - 4) Type
 - 5) Fittings to be used
 - 6) Method of attachment to structure
 - 7) Firestop system assembly information for each system to be installed:
 - a) Documentation from UL catalog for each system proposed. This documentation shall include the following information:

- i) Firestop manufacturer
- ii) UL system number
- iii) F, T, and L Ratings
- iv) The complete description of the firestop system; To include what specific construction the system is intended to pass through such as a wall or floor assembly, the penetrating items allowed to pass through the opening in the wall or floor assembly, and the materials designed to prevent the spread of fire through the openings.

8) As well as any additional information required by individual sections of this Division

2. Shop Drawings

- a. Submit for review scaled layout drawings showing the size/routing of all pathways and the size/information/locations of all boxes, pullboxes, firestopping systems, and access panels.
 - 1) Each pathway shall be identified by type and size on the drawings.
 - a) Example #1: 4" EMT
 - b) Example #2: 4" x 12" Cable Tray
 - 2) Each grounding conductor shall be identified by size (and insulation):
 - a) Example: #3/0 insulated ground
 - 3) Each firestop system shall be identified by Manufacturer and Product, as well as UL system number for that particular location.
 - a) Example #1 – Firestopping Sleeve:
EZ-Path Series 22, UL System W-L-3255
 - b) Example #2 – Backbox in Fire-Rated Wall:
Specseal Power Shield, UL System QCSN/CLIV.R14288
 - 4) Each pullbox and access panel shall be identified by size and height above finished floor.
 - a) Pullbox Example: Pullbox 8" x 24" x 40" approximately 12' AFF.
- b. Unless otherwise required by these specifications, it is permissible to show pathways systems (conduit, cable tray, auxiliary supports, etc.) on the same shop drawing along with the cabling and system work to be installed through those pathways.
 - 1) Division 274100 "Audio Video Systems" and their individual pathways shall be separate shop drawings; shared pathways such as cable tray shall be shown on both shop drawings.

D. Project Completion

1. Record Drawings:

- a. The Quality Control Specialist shall review the installation and Record Drawings for the Common Work Results required for their scope of work and shall stamp the final Record Drawings with their RCDD or CTS-I stamp before submission. By stamping the Record Drawings, the Quality Control Specialist indicates that the Common Work Results have been installed per the Contract Documents and all associated codes, standards, and guidelines, and all changes to the drawings have been incorporated into the Record Drawings.

2. Pictures of each Firestopping System (with visible label).

1.7 QUALITY ASSURANCE

- A. Submittals and Shop Drawings for all Common Work Results specified in this section shall, if not created by, be reviewed by the Quality Control Specialist.
 - 1. The Quality Control Specialist shall stamp all relevant submittals for their associated Division 27 sections, which indicates that at a minimum the proposed work has been reviewed by them and found to be in compliance in regards to:
 - a. All applicable codes and industry standards and guidelines referenced in Division 27.
 - b. Being fully-coordinated with all other trades and to be installed per the Construction Documents.
 - c. And installed per manufacturer's direction.
- B. The Quality Control Specialist shall also make weekly inspections during construction to ensure all work installed per this section is correct.
 - 1. Any deficiencies encountered prior to and during installation shall be corrected by the installing contractor under the direction of the Quality Control Specialist and/or the Design Consultant.
- C. Firestopping Systems
 - 1. Firestopping material and systems shall be tested and listed by UL. All firestopping products shall bear this classification marking.
 - 2. Installation technicians shall be by qualified and trained personnel. Acceptable installer qualifications are as follows:
 - a. FM Research, approved in accordance with FM AS 4991.
 - b. Individuals who are trained and certified by the firestopping manufacturer. For Specified Technologies, all installers shall have current FIT Level 1 certification.

1.8 NOISE CRITICAL SPACES

- A. Many areas of the building, referred to as "noise-critical spaces", require special attention (special acoustical provisions and restrictions). The list below designates the noise-critical spaces that will require application of sound attenuating measures and acoustical sealants or sleeves.
 - 1. Sound/Lighting Control Rooms
 - 2. Drama Theatres

PART 2 - PARTS AND MATERIALS

2.1 GROUNDING AND BONDING FOR COMMUNICATIONS

- A. Refer to drawings and Division 27 Sections "Audio Video Systems" for exact grounding and bonding requirements.

2.2 PATHWAYS FOR COMMUNICATIONS SYSTEMS

- A. General
 - 1. All non-continuous cable supports shall be designed to prevent degradation of cable performance

- and pinch points that could damage cable
- 2. Non-continuous cable supports shall have flared edges to prevent damage while installing cables.
- 3. Telecommunications pathways shall be routed back to serving Communications Room. Refer to Drawings for additional information.

B. Cable Hook Systems (“J-hooks”)

- 1. The following manufacturers are Conditionally Approved.
 - a. Cooper/B-Line
 - b. Erico/Caddy
 - c. Monosystems
 - d. Panduit
 - e. Snake Tray
 - f. Or Approved Substitution (submitted and accepted in the “pre-bid” phase)
- 2. Specifications
 - a. Have a flat bottom and sufficient width to comply with the minimum bend radius of all cabling as required by the referenced standards and manufacturers recommendations
 - b. Be open for easy lay-in and removal of cabling
 - c. Be designed so the mounting hardware is recessed to prevent cable damage
 - d. Cable hooks for non-corrosive areas shall be pre-galvanized steel, ASTM A653. Where additional strength is required, cable hooks shall be spring steel with a zinc-plated finish, ASTM B633, SC3
 - e. Cable hooks for corrosive areas shall be stainless steel, AISI Type 304
 - f. Be factory assembled for direct attachment to walls, hanger rods, beam flanges, purlins, strut, floor posts, etc. to meet job conditions
 - g. Be factory assembled multi-tiered cable hooks shall be used where required to provide separate cabling compartments, or where additional capacity is needed
- 3. Cable hooks for installation above ceilings shall be
 - a. B-Line series BCH21, BCH32, BCH64
 - b. Caddy CABLE-CAT 21 or 32 series hangers
 - c. Or equivalent from Conditionally Approved manufacturer

C. Conduit

- 1. Specifications
 - a. Refer to Electrical Division 26 for specific product and material information.
 - 1) Sizes, methods, and more stringent requirements shall be adhered to when specified in this Division.
 - b. Conduits provided as connection to incoming services, utilities, including private services to other buildings or outside connection points shall be rigid metal or intermediate metal conduit at the point it enters the building, emerges from an exterior wall or ground floor slab to the final termination/transition point.
 - c. If services enter a room or space such as a mechanical room, electrical room or other intermediate room due to convenience or proximity to the exterior and adequate space has not been provided within 50 feet (15.3 m) for the equipment needed for transitioning these and future cables/services to an appropriately rated indoor cable then those conduits shall be continued uninterrupted (except for necessary pull boxes) to the final connection point or

location where the transition point has been designated. Generally this connection point will be a designated Entrance Room for Communications or the Main Telecommunication space. If space has not been identified the contractor shall request information prior to bid.

- d. Provide conduit as indicated on the Drawings or required by this Specification. Minimum conduit size shall be 1 inch (25.4 mm). Provide a polypropylene or monofilament plastic line with not less than 200-lb (90.7 kg) tensile strength in each empty conduit. Permanently mark or tag each conduit or pull box, identifying it as communications (Telecom), AV, TV, Broadcast, Intercom, etc.), at intervals of not more than 75 feet (22.9 m). Each conduit that is stubbed into the ceiling space from an outlet box shall be permanently marked or tagged; refer to Labeling requirements in Section 3 – Execution.
- e. Route an empty conduit from each outlet box into the ceiling space above and terminate with a nylon bushing. In rooms with a non-accessible ceiling, route conduits to the nearest accessible corridor ceiling or communications space.

<u>Number of Telecommunications Outlets/Connectors</u>	<u>Conduit Size</u>
Up to 4	1 inch (25.4 mm)
Up to 9	1-1/4 inch (31.8 mm)

D. Acoustical Pathway

1. Specifications

- a. For use in non-rated walls only.
- b. For use in place of conduit sleeves through walls of noise critical spaces.
- c. Plenum Rated (to UL2043)
- d. Sound Transmission Classification (STC) as tested per ASTM E90 shall be greater than 60.

2. Manufacturer shall be:

- a. Hilti CS-SL SA
- b. Specified Technologies, Inc. - NEZ33

E. Surface Raceways

1. The following manufacturers are Conditionally Approved.

a. Surface Metal Raceways

- 1) Hubbell
- 2) Legrand/Wiremold
- 3) Mono-Systems Inc.
- 4) Panduit
- 5) Or Approved Substitution (submitted and accepted in the “pre-bid” phase)

b. Surface Nonmetallic Raceways

- 1) Hubbell
- 2) Legrand/Wiremold
- 3) Mono-Systems Inc.
- 4) Panduit
- 5) Or Approved Substitution (submitted and accepted in the “pre-bid” phase)

2. Specifications

- a. Raceways shall be sized per the quantity and size of the installed cables, plus 50% spare capacity. Minimum cross-sectional area shall be 1 inch.
 - b. Single gang and double gang surface boxes shall be a minimum of 2-1/2 inches deep.
 - c. Color shall be as directed by the Architect.
3. Manufacturer shall be:
- a. Submit product cutsheet(s) from Conditionally Approved manufacturer listed above.
- F. Outlet Boxes
1. Specifications
- a. Boxes shall either be square or rectangular, as noted on the drawings. Dimensions indicate minimum size.
 - b. Telecommunications – for outlets shown on T or TN series drawings:
 - 1) For stud walls: dual-gang outlet box shall be a minimum size of 4-11/16 inches (119.1 mm) width by 4-11/16 inches (119.1 mm) height by 2-1/8 inches (54 mm) depth, with a dual-gang or single-gang raised cover/extension ring (as indicated on the drawings) a minimum of 3/8" deep. Depth shall match that of wall gypsum board(s).
 - a) Double gang – RACO 258/259 (Coordinate knock-out size with conduit size indicated on drawings); or
 - b) RANDL T-55017; or
 - c) Or equivalent from
 - i) Emerson/Appleton
 - ii) Thomas & Betts/Steel City
 - iii) Approved Substitution
 - 2) For ceilings (flush or above accessible ceiling): plenum-rated, dual-gang outlet box shall be a minimum size of 4 inches (101.6 mm) width by 4 inches (101.6 mm) height by 2-1/8 inches (54 mm) depth, with a dual-gang or single-gang raised cover/extension ring (as indicated on the drawings) a minimum of 3/8" deep. Depth shall match thickness of gypsum ceiling board(s) or accessible ceiling panel (if applicable).
 - a) Double gang – RACO 239 or equivalent, with ceiling grid framing where installed in accessible ceiling.
 - b) Or equivalent from
 - i) Emerson/Appleton
 - ii) Thomas & Betts/Steel City
 - iii) Approved Substitution
 - 3) For 6" or 8" deep masonry walls: where single-gang faceplates are shown on the drawings, provide single-gang backbox a minimum of 3-1/2 inches deep; where double-gang faceplates are shown on the drawings, provide double-gang backbox a minimum of 3-1/2 inches deep.
 - a) Single gang – RACO 695
 - b) Double gang – RACO 696
 - 4) Weatherproof: Aluminum die cast, weatherproof box with 1" conduit connection. Where single-gang faceplates are shown on the drawings, provide single-gang backbox a minimum of 2-1/2 inches deep; where double-gang faceplates are shown on the drawings, provide double-gang backbox a minimum of 2-1/2 inches deep.

- a) Single gang – Thomas and Betts – IHD3-3 or equivalent
 - i) Or equivalent from
 - (1) Emerson/Appleton
 - (2) Hubbell/RACO
 - (3) Approved Substitution
- b) Double gang – Thomas and Betts – 2IHD5-3 or equivalent
 - i) Or equivalent from
 - (1) Emerson/Appleton
 - (2) Hubbell/RACO
 - (3) Approved Substitution

G. Pull Boxes – for interior use only

1. Specifications

- a. NEMA 1
- b. Refer to Execution section for sizing requirements.

2. The following manufacturers are Conditionally Approved.

- a. NEMA Enclosures
- b. Wiegmann
- c. Or Equivalent

H. Flexible cable tray

1. The following manufacturers are Conditionally Approved.

- a. Atkore/Cope
- b. Bettermann Group/Chalfant
- c. Chatsworth
- d. Eaton/Cooper B-Line
- e. Hubbell
- f. Legrand/Cablofil
- g. MonoSystems
- h. MPHusky
- i. nVent/Hoffman
- j. Schneider Electric/WIBE
- k. Snake Tray
- l. Thomas & Betts
- m. WBT LLC
- n. Or Approved Substitution (submitted and accepted in the “pre-bid” phase)

2. Specifications

- a. *Cable Tray Size: Size identified on drawings indicate minimum width and depth size. Provide cable tray of sufficient size to accommodate a maximum calculated fill ratio of 50% for all Division 27 cabling, to include all cables installed plus 25% growth.*
- b. Cable tray systems shall be pre-fabricated structures for supporting and routing cables or conductors that are pulled or laid in place after the pathway has been installed as a complete system
- c. Flexible cable tray systems shall consist of straight sections, fittings, and accessories as necessary for a complete, continuously grounded system.

- 1) Cable tray and accessories shall be UL Classified as an equipment ground conductor.

- d. Wire basket shall be made of high strength steel wires and formed into a standard 2 inch by 4 inch wire mesh pattern with intersecting wires welded together. All wire ends along wire basket sides (flanges) shall be rounded during manufacturing for safety of cables and installers.
- e. Cable Tray Materials: Steel rod and/or wire; corrosion resistant to the degree suitable for the environment where it is to be installed; field-bendable.
- f. Cable Tray Types:
 - 1) Wire cable tray: a cable tray manufactured from metal wire welded at all intersections and is formed to provide a channel for the cables.
- g. Color: Cable tray shall be powder coated color as selected by Architect

I. Firestopping systems

J. General

- 1. All firestopping systems for Division 27 conduit, sleeves, cabling, boxes, etc. shall be from a single manufacturer, unless otherwise noted.
- 2. The following manufacturers are Conditionally Approved.
 - a. 3M
 - b. Hilti
 - c. Specified Technologies, Inc
- 3. Communications ladder rack and cable tray shall not continue through a fire-rated wall. Stop the tray, install multiple fire-rated pathway devices, and continue tray on the other side. Ensure grounding of the tray is continuous through the wall.

K. Fire-Rated Pathway Device – for sleeves through a single penetration (wall or floor)

- 1. Specifications
 - a. Minimum performance requirements: Shall meet testing requirements of ASTM E-814 or U.L. 1479; Shall be installed in accordance with the NRTL. Provide fire stop systems appropriate for the specific application and in accordance with manufacturer’s instructions.
 - b. Shall meet or exceed the ratings of the wall or floor that it penetrates.
 - c. Shall be a pre-fabricated and zero-maintenance solution which requires no action to activate the fire and smoke protective characteristics of the device.
 - d. Allows the installation and removal of cables without the need to remove or add any materials.
 - e. Used to seal penetrations of cables through fire rated partitions
 - f. Not subject to the single manufacturer requirement
- 2. Manufacturer shall be:
 - a. EZ-Path family of products by Specified Technologies Inc.
 - b. Hilti Firestop Speed Sleeve CP 653 Series
 - c. Wiremold Flamestopper

L. Firestopping for Backboxes in Fire-Rated Walls

- 1. Specifications

- a. Used to seal backboxes in fire rated partitions.
- b. Minimum performance requirements: Shall meet UL testing requirements of UL 263 and classified as Wall Opening Protective Material (QCSN or CLIV); Shall be installed in accordance with the NRTL. Shall meet or exceed the ratings of the wall or floor that it is located in.
- c. Provide fire stop systems appropriate for the specific application and in accordance with manufacturer's instructions.

2. Manufacturer shall be:

- a. Hilti CP 617 or CFS-P PA
- b. Specified Technologies Inc., SpecSeal Power Shield
- c. Or equivalent from Conditionally Approved manufacturer.

M. Firestopping for Thru-Wall (or Floor) Conduit Penetrations and Other Applications

- 1. For fire-rated penetrations where the conduit pathway extends beyond a single fire-rated partition/floor, and other required firestopping applications not previously addressed in this specification.
- 2. Specifications:
 - a. Shall be UL listed for the specific application; Shall meet or exceed the ratings of the wall or floor that it penetrates.
- 3. Manufacturer shall be:
 - a. Hilti – submit UL System documentation for each floor/wall type and product cutsheets for all Hilti materials to be utilized
 - b. Specified Technologies Inc. – submit UL System documentation for each floor/wall type and product cutsheets for all STI materials to be utilized
 - c. Or equivalent from Conditionally Approved manufacturer.

2.3 ACCESS PANELS

A. Access Panels

- 1. Where pullboxes are required above inaccessible ceiling spaces, or for other required conditions, provide an appropriately-sized access panel. The following manufacturers are Conditionally Approved.
 - a. Activar/J.L Industries
 - b. Acudor Products
 - c. Alfab/Barco
 - d. Elmdor Products
 - e. Karp Associates, Inc.
 - f. Milcor
 - g. Nystrom Building Products
 - h. Williams Brothers
 - i. Wind-lock
 - j. Or Approved Substitution (submitted and accepted in the “pre-bid” phase)
- 2. Specifications:

- a. Steel Access Doors and Frames: Factory-fabricated and assembled units, complete with attachment devices and fasteners ready for installation.
 - b. Joints and seams: continuously welded steel, with welds ground smooth and flush with adjacent surfaces.
 - c. Frames: 16-gauge steel, with a 1 inch (25.4 mm) wide exposed perimeter flange for units installed in unit masonry, pre-cast, or cast-in-place concrete, ceramic tile, or wood paneling:
 - 1) For installation in masonry, concrete, ceramic tile, or wood paneling: 1-inch-wide-exposed perimeter flange and adjustable metal masonry anchors.
 - 2) For gypsum wallboard or plaster: perforated flanges with wallboard bead.
 - 3) For full-bed plaster applications: galvanized expanded metal lath and exposed casing bead, welded to perimeter of frame.
 - d. Flush Panel Doors: 14-gauge sheet steel, with concealed spring hinges or concealed continuous piano hinge set to open 175 degrees; factory-applied prime paint.
 - e. Fire-Rated Units: Insulated flush panel doors, with continuous piano hinge and self-closing mechanism.
- 3. Locking Devices: Where indicated, provide 5-pin or 5-disc type cylinder locks, individually keyed; provide 2 keys.
 - 4. Indicate proposed size and locations on pre-construction shop drawings. No access panels shall be installed without Architect and Design Consultant approval.

2.4 IDENTIFICATION FOR COMMON WORK FOR COMMUNICATIONS SYSTEMS

A. Labels

- 1. The following manufacturers are Conditionally Approved for generic labeling requirements for conduits, pullboxes, and equipment racks.
 - a. Brady
 - b. Brother
 - c. Dymo
 - d. HellermannTyton
 - e. Panduit
 - f. Or Approved Substitution (submitted and accepted in the “pre-bid” phase)
- 2. Specifications:
 - a. Refer to additional requirements in Part 3 – Execution.
 - b. Refer to individual sections for additional identification requirements for specific work.

2.5 KEYS

- A. Supply two copies of every key as required for pullboxes, junction boxes, and access panels.

PART 3 - EXECUTION

3.1 PATHWAYS FOR COMMUNICATIONS

A. General

1. All supports shall be specifically designed to support the required cable weight and volume. Field manufactured supports will not be accepted.
2. Install a pull cord in each pathway (empty or not) for installation of new wires or cables. Use polypropylene or monofilament plastic line with not less than 200 lb (90.7 kg) tensile strength. Leave at least 12 inches (304.8 mm) of slack at each end of pull cord.
3. Unless otherwise noted, pathway routing shown on the Drawings is illustrative only and meant to indicate the general configuration of the work. Install pathways so that adequate clearances and offsets between pathways and other trades are provided. Coordinate all pathways with other trades prior to installation.
4. All pathways shall include empty space for a minimum of 25% growth beyond initial installation of cabling.
5. Cables shall be rigidly supported by cable pathways as indicated on the drawings. Cables shall be physically supported at intervals not to exceed 5 feet (1.52 m).
6. Store and keep dry all products in original container in a climate controlled environment until installation is to occur
7. Install all communications pathways:
 - a. So that cables are allowed to be pulled in accordance with referenced standards and guidelines.
 - b. So that cables are allowed to be pulled without damage to conductors, shield, armor, or jacket.
 - c. So that cables are not forced or allowed to exceed minimum allowed bend radius by manufacturer or referenced standards and guidelines.
 - d. So that the maximum allowable pulling tension is not exceeded.
 - e. To meet the requirements of the structure and the requirements of all other Work on the Project
 - f. To clear all openings, depressions, ducts, pipes, reinforcing steel, and so on.
 - g. Within or passing through the concrete structure in such a manner so as not to adversely affect the integrity of the structure. Become familiar with the Architectural and the Structural Drawings and their requirements affecting the raceway installation. If necessary, consult with the Architect.
 - h. Parallel or perpendicular to building lines or column lines.
 - i. When concealed, with a minimum of bends in the shortest practical distance, considering type of building construction and obstructions, unless otherwise indicated.
8. Cables shall remain unattached to pathways or other cables and shall simply lay at rest on the supports provided by its pathway (including cable trays, wire basket, j-hooks, conduit, etc.). Wire ties, velcro straps, electrical tape or other methods shall **not** be used to attach cables to cable supports; UON.
 - a. Except when supported by ladder racking within each Telecommunications room, UON.
9. Provide adequate communications pathways so that cabling is not forced to attach, be supported, or use other pathways not specifically designed and provided for communications cabling purposes. Any deviation from this will not be accepted.
 - a. At no point shall cables come in contact with, be supported by, or attach to other trades equipment or supports. UON
 - b. At no point shall cables come in contact with, be supported by, or attach to building structures or supports; UON
10. Provide appropriately sized sleeves where cables are required to pass through non-rated full-height partitions. Where allowed, sleeves shall extend a minimum of 3 inches (76.2 mm) beyond the partition surface on both sides, and shall be rigidly supported to support the weight of cables. Sleeves shall be sized so that no more than 50% of the cross-sectional area is utilized by the

- cabling to be installed. The minimum inside diameter of each sleeve shall be nominal 2 inches (50.8 mm).
11. Suspended cables shall be installed with at least 3 inches (76.2 mm) of clear vertical space above the ceiling tiles and support channels (T-bars).
 12. Waterproofing
 - a. Avoid, if possible, the penetration of any waterproof membranes such as roofs, machine room floors, basement walls, and the like. If such penetration is necessary, make penetration prior to the waterproofing and furnish all sleeves or pitch-pockets required. Advise the Architect and obtain written permission before penetrating any waterproof membrane, even where such penetration is shown on the Drawings.
 - b. Restore waterproofing integrity of walls or surfaces after they have been penetrated without additional cost to the Owner.
 13. Cutting and Patching
 - a. Where cutting, channeling, chasing or drilling of floors, walls, partitions, ceilings or other surfaces is necessary for the proper installation, support or anchorage of conduit or other equipment, layout the work carefully in advance. Repair any damage to the building, piping, equipment or defaced finished plaster, woodwork, metalwork, etc. using skilled tradespeople of the trades required at no additional cost to the Owner.
 - b. Do not cut, channel, chase or drill masonry, tile, etc., unless permission from the Architect is obtained. If permission is granted, perform this work in a manner acceptable to the Architect.
 - c. Patch around all openings to match adjacent construction.
 - d. Where conduit or equipment is mounted on a painted finished surface, or a surface to be painted, paint to match the surface. Cold galvanize bare metal whenever support channels are cut.
 - e. Provide slots, chases, openings and recesses through floors, walls, ceilings, and roofs as required. Where these openings are not provided, provide cutting and patching to accommodate penetrations at no additional cost to the Owner.
 - f. After the final waterproofing membrane has been installed, roofs may be cut only with written permission by the Architect.
 14. Mounting Heights
 - a. Mounting heights for equipment and devices requiring operational access shall conform to ADA requirements.
 - 1) Wall mounted devices requiring operational access shall be mounted a minimum of 15 inches above finished floor to bottom of device and a maximum of 48 inches above finished floor to top of device.
 - b. Mounting heights shall be from floor to center of device, unless otherwise noted. Verify exact locations and mounting heights with the Architect before installation.
 - c. Typical mounting heights shall match nearest adjacent typical electrical outlet mounting height UON or as directed by the Architect.
 15. Painting
 - a. Paint exposed ferrous surfaces, including, but not limited to, hangers, equipment stands and supports using materials and methods as specified elsewhere in the specification documents; colors shall be as selected by the Architect.
 - b. Re-finish all field-threaded ends of galvanized conduits and field-cut ends of galvanized supports with a cold-galvanizing compound approved for use on conductive surfaces. Follow closely manufacturer's instructions for pre-cleaning surfaces and application.
 - c. Factory finishes and shop priming and special finishes are specified in the individual

equipment Specification sections.

- d. Where factory finishes are provided and no additional field painting is specified, touch-up or refinish, as required by, and to the acceptance of, the Architect and Design Consultant, marred or damaged surfaces so as to leave a smooth, uniform finish. If, in the opinion of the Architect or Design Consultant, the finish is too badly damaged to be properly re-finished, replace the damaged equipment or materials at no additional costs to the Owner.
- e. Provide touch-up paint as required by Specification Sections in this Division.

16. Fastenings

- a. Fasten equipment to building structure in accordance with the best industry practice.
- b. Where weight applied to the attachment points is 100 pounds or less, conform to the following as a minimum:
 - 1) Wood: Wood screws.
 - 2) Concrete and solid masonry: Bolts and expansion shields.
 - 3) Hollow construction: Toggle bolts.
 - 4) Solid metal: Machine screws in tapped holes or with welded studs.
 - 5) Steel decking or sub-floor: Fastenings as specified below for applied weights in excess of 100 pounds.
- c. Where weight applied to building attachment points exceeds 100 pounds, but is 300 pounds or less, conform to the following as a minimum:
 - 1) At concrete slabs provide 24 inch x 24 inch x ½ inch steel fishplates on top with through bolts. Fishplate assemblies shall be chased in and grouted flush with the top of slab screed line, where no fill is to be applied.
 - 2) At steel decking or sub-floor for all fastenings, provide through bolts or threaded rods. The tops of bolts or rods shall be set at least one inch below the top fill screed line and grouted in. Suitable washers shall be used under bolt heads or nuts. In cases where the decking or sub-floor manufacturer produces specialty hangers to work with his decking or sub-floor such hangers shall be provided.
- d. Where weight applied to building attachment points exceeds 300 pounds, coordinate with and obtain the approval of Architect and conform to the following as a minimum:
 - 1) Provide suitable auxiliary channel or angle iron bridging between building structural steel elements to establish fastening points. Bridging members shall be suitably welded or clamped to building steel. Provide threaded rods or bolts to attach to bridging members.
- e. For items, which are shown as being ceiling mounted at locations where fastening to the building construction element above is not possible, provide suitable auxiliary channel or angle iron bridging tying to the building structural elements.
- f. Wall mounted equipment may be directly secured to wall by means of steel bolts. Groups or arrays of equipment may be mounted on adequately sized steel angles, channels, or bars. Prefabricated steel channels as manufactured by Kindorf or Unistrut are acceptable.

17. Areas identified as noise critical spaces shall have all penetrations sealed to minimize sound transmission between adjacent spaces. Install Acoustical Pathway(s) through walls of noise critical spaces

B. Access to pathways and associated equipment

- 1. Locate all cable trays, open hanger cable supports, j-hooks, pull boxes, junction boxes and fire

- stopping systems so as to provide easy access for operation, service inspection and maintenance.
2. Provide an Access Panel where equipment or devices are located above inaccessible ceilings. Where access doors are necessary but not shown on the plans, coordination type and location with Architect and Design Consultant through an RFI.
 - a. Pathways requiring access such as open hanger cable supports, j-hooks, and cable trays shall have an access door or other means of direct access at a minimum of 10 feet (3 m) intervals.
 - b. Cables or cable pathways requiring access such as open hanger cable supports, j-hooks, and cable trays may not change directions above an inaccessible ceiling unless complete access to the change of direction in pathway or cable route is within arms reach 3 feet (0.9 m) from adjacent accessible point.
 3. Maintain all code required clearances and clearances required by manufacturers.

C. Cable distribution

1. Provide pathways for Audio Video Systems to allow cabling to be installed in the following manner:
 - a. For existing walls:
 - 1) For stud walls - "Ring and String": Mud ring for faceplate, cabling run in hollow cavity of the wall and then j-hooks are utilized back to the nearest cable tray or serving Telecommunications Room/Space
 - 2) For masonry or inaccessible walls – Surface-mounted raceway.
 - b. See drawings for clarification.

D. Conduits

1. Conduit shall be of the appropriate type required by code and as required by Electrical Division 26.
2. Adequate access shall be available where cables enter conduits
3. Bond and ground all metallic conduits and boxes in accordance with national or local requirements and with TIA-607B – "Generic Telecommunications Bonding and Grounding (Earthing) for Customer Premises.
4. Install conduits in the most direct route possible, running parallel to building lines
5. Ream all conduit ends and fit them with an insulated bushing to eliminate sharp edges that can damage cables during installation or service.
6. Conduits which enter Telecommunications rooms shall extend 3 inches (76.2 mm) AFF or through the wall.
7. Conduits which enter Entrance Facilities shall extend 4 inches (101.6 mm) AFF or below the finished ceiling (if exists).
8. Flexible conduits may only be used where specifically allowed by these contract documents.
 - a. Flexible conduit sections shall be less than 20 feet (6.1 m) in length.
9. No continuous section of a conduit may exceed 100 feet (30.5 m) without a pullbox.
10. No more than (2) 90° bends, or equivalent will be allowed between pullboxes.
 - a. Each and any offset shall be considered a 90° bend.
 - b. A pullbox is required wherever a reverse bend is installed.
11. The minimum bend radius for conduits is

- a. (6) times the inside diameter for 2 inches (50.8 mm) conduits or less.
 - b. (10) times the inside diameter for conduits greater than 2 inches (50.8 mm).
12. Any single conduit run may not serve more than (1) outlet location unless expressly indicated on the drawings.
13. Conduits shall contain no electrical condulets (also known as LBs).
- a. Exception: Pre-approved (by the Design Consultant) condulets specifically manufactured for communications cabling and will maintain minimum bend radius for cabling to be installed. These locations are to be called out on the shop drawings.
 - b. Requirements
 - 1) Refer to applicable details on drawings for illustrative requirements.
 - 2) Wherever practical, slab-on-grade floorboxes shall have conduit extended underground or in-slab from box to serving communications room or equipment cabinet.
 - a) Only one horizontal bend is allowed, 90 degrees or less.
 - b) Indicate proposed routing and stub-up locations on shop drawings.
 - 3) Route all underground conduit so there is no more than (3) 90 degree bends, including stub-up bend at communications room/equipment cabinet.
 - a) For underground conduit serving outlets/boxes outside the footprint of the building that require more than (3) 90 degree bends, provide appropriately-sized handhole(s). Coordinate location with Architect and Owner, indicate proposed location(s) on shop drawings, and include product information in pre-construction submittals. In general, handholes are not to be located in roadways, parking lots, sidewalks, or any location that may be subject to vehicular traffic.
 - 4) Approved conduit types:
 - a) When routed in slab-on-grade:
 - i) Horizontal conduit shall be RMC or Schedule 40 PVC, including horizontal bends. If PVC is installed, also install tracer wire.
 - ii) Vertical bends shall be RMC.
 - b) When routed below slab-on-grade or outside the footprint of the building:
 - i) Horizontal conduit shall be RMC or Schedule 40 PVC a minimum of 12" below grade. If PVC is installed, also install tracer wire.
 - ii) All vertical and horizontal bends shall be RMC.

E. Outlet boxes

- 1. No outlet boxes shall be located back-to-back in a wall cavity.
 - a. Where possible offset to next stud cavity, with a minimum of 6 inch (152.4 mm) separation.
- 2. Outlet boxes shall be within 3 feet (0.9 m) of nearest electrical outlet.
- 3. Outlet boxes located in fire-rated walls are to have the appropriate firestopping for backboxes. These locations are to be identified on shop drawings.
- 4. Where cabling enters a backbox directly (not via conduit), provide black rubber grommet on knockout.

F. PullBoxes

- 1. Pullboxes shall be placed in Conveniently Accessible locations.
- 2. Coordinate the location and installation of all pullboxes to ensure adequate access is provided.

3. Pullboxes above an accessible ceiling shall:
 - a. Be aligned directly over the ceiling grid to allow access
 - b. Be installed with a minimum of 3 inches (76.2 mm) clearance to ceiling grid and tiles
4. No directional changes shall be allowed in pullboxes. Conduit Shall continue in the same direction as it enters and then change direction via an appropriately sized bend in the conduit.
5. Size pullboxes according to the following chart (all sizes are minimums):

Conduit Trade Size	Width	Length	Depth	Width Increase for Additional Conduit (of same size)
¾" or smaller	4"	4"	2-1/8"	Not applicable
1"	4"	16"	3"	2"
1-1/4"	6"	20"	3"	3"
1-1/2"	8"	28"	4"	4"
2"	8"	36"	4"	5"
2-1/2"	10"	42"	5"	6"
3"	12"	48"	5"	6"
4"	16"	60"	8"	6"

G. Cable Tray

1. Cable trays shall be installed in accordance with the applicable electrical code and standards.
2. The inside of the cable support system shall be free of burrs, sharp edges or projections that can damage cable insulation. Abrasive supports (e.g., threaded rod) installed within the cable fill area shall have that portion within the tray rigidly protected with a smooth, non-scratching covering so that cable can be pulled without physical damage such as appropriately rated (plenum) plastic tubing.
3. Cables shall remain unattached to its pathway and shall simply lay at rest on the supports provided by its pathway. Wire ties, velcro straps, electrical tape or other methods shall **not** be used to attach cables to cable supports; UON.
4. Installation of cables shall not exceed the fill requirements stated above.
5. Cable trays shall not extend through fire-rated walls and walls for noise critical spaces.
6. Cable trays shall not extend over 6' lengths (or greater) of inaccessible ceilings. Stop cable trays just before the inaccessible ceiling and provide overhead conduits of quantity and size bridging the two sections of cable tray so that conduit cable capacity (square inches per fill ratio) is equal to that of the cable tray.
 - a. The cable fill ratio for cable tray shall be 50%.
 - b. The cable fill ratio for conduits shall be 40%.
 - c. Example: a 4" x 12" cable tray has 48 square inches of total capacity, and 24 square inches of cable capacity. Per the NEC, a 4" trade size EMT conduit has a 40% cable capacity of 4.62 inches. 24 divided by 4.62, rounding up to the next whole number equals (6) 4" conduits shall be provided for a 4" x 12" cable tray.
7. Cable trays and cable runways shall not be used as walkways or ladders.
8. A minimum of 12 inches (300 mm) access headroom shall be provided and maintained above a cable tray system or cable runway.
9. Care shall be taken to ensure that other building components (e.g., air conditioning ducts, pipes, conduits) do not restrict access.
10. Flexible cable trays shall be supported according to manufacturer's instruction via one of the following:
 - a. Trapeze/Unistrut under the cable connected to the cable tray and to (2) 3/8" (or greater) rods to structure above.
 - 1) Center-hung, single-rod supports are not allowed.

- b. Shelf or L-brackets attached to wood or metal studs.
11. Test cable tray systems to ensure electrical continuity of bonding and grounding connections, and to demonstrate compliance with maximum grounding resistance.

3.2 LABELING

A. Labeling Installation

1. Labels that are to be secured by adhesive. They shall have a type of adhesive that is appropriate for the particular surface upon which the label is to be installed. The mounting surface shall be free of dust, dirt, oil, etc. that would impede the adhesion of the labels.

B. Labeling Requirements

1. Labels are to be installed on:
 - a. All firestopping systems. For wall and floor penetrations, label on both sides. See Firestopping later in this section. Take picture of each firestopping system (with label visible) to include with Project Completion submittal.
 - b. All pathways (e.g., conduit, innerduct, etc.) installed under this work.
 - 1) Label all conduit and innerduct with “TELECOM” or “AV” according to the intended system/use of the installed (or future) cabling. Conduit labels shall utilize text readable from a standing position on the finished floor. Conduit sleeves which pass through a single wall or floor need not be labeled.
 - a) For wall stub-up locations, label overhead only.
 - b) For conduits greater than 10’, label both ends of conduit with far end location and Room/Number.
 - i) Example – “AV to AV Rack R01”.
 - c) For conduits that stub directly up or into a Communications Room, label both ends of conduit.
 - i) Example: underslab conduit from Telecom Room 1A to the Floor Box in Conference Room 101A shall be labeled as follows:
 - (1) Conduit stub-up location in Telecom Room 1A – “Telecom to Conf. Rm 101A Floorbox”
 - (2) Bottom of floorbox, immediately adjacent to serving Telecom conduit – “Telecom to Telecom Room 1A”
 - 2) All pullboxes and junction boxes for Communications shall be labeled such as “TELECOM PULLBOX”, “AV JUNCTION BOX”, “TV”, etc. on the cover, such that the text is of sufficient size to be readable from a standing position on the finished floor.
 - a) Conduits entering and exiting all pullboxes and junction boxes shall be labeled with their destination/room number – ie “To AV Box Q:212:01 in Control Rm 212”.
 - 3) In addition to the above labeling requirements, for pathways above accessible ceiling, paint the cover of all pullboxes/junction boxes purple and stripe all conduits every 5’ with that color.
 - a) In general, the label is to be provided and installed by whomever installed the item that is being labeled.
 - b) Refer to individual Division 27 Communications sections and to the drawings for additional information on labeling requirements.

3.3 FIRESTOPPING

A. General

1. Provide fire-resistant materials of a type and composition necessary to restore fire ratings to all wall, floor or ceiling penetrations; including membrane penetrations. All materials shall be classified or listed as a complete system by UL (or an approved NRTL by the Design Consultant and AHJ) and meet NEC and local codes. The use of partial systems or components of systems is not allowed unless specifically identified in the documents.
2. All penetrations through fire rated floors and walls shall be sealed to prevent the passage of smoke, flame, toxic gas or water through the penetration before, during or after a fire. The fire rating (F and T) of the penetration seal shall be at least that of the floor or wall into which it is installed, so that the original fire rating of the floor or wall is maintained as required by referenced building codes.
 - a. Assume all floors are fire-rated, unless otherwise noted.
 - b. Also install fire stops at any other locations indicated in the Specifications or Drawings.
3. Provide a label on both sides of fire rated assembly at all fire stop locations indicating:
 - a. Fire stop Manufacturer
 - b. Installer and company
 - c. Date installed
 - d. UL system number with all relevant ratings indicated
4. Include labels in each telecom room in which one or more fire rated walls is installed. Provide a 2” block letter stencil label on the inside of the telecom room to indicate rating for each barrier.
5. Provide systems as identified on the drawings and specified herein. At locations where the cabling routing encounters a fire-rated barrier provide an adequately sized fire stop device for the quantities and types for all cables to be installed plus 25% growth.

B. Penetration Sealant – Conduits

1. Provide listed system to seal around openings between wall, floor or partition around conduits in accordance with system listing and manufacturer’s instructions.

C. Penetration Sealant – Voids, Cavities, and Openings

1. Install fire stop materials in the framed openings through fire rated partitions per the Architect's drawings and in accordance with the NRTL listed system instructions.
2. Fire stop all voids, cavities, and openings left by the removal of cabling, conduits, conduit sleeves, cable trays or other equipment related to the communications systems not to be reused.
3. Install the fire stop system in accordance with the manufacturer's instructions and local codes.

D. Fire-Rated Pathway Device

1. Provide fire-rated pathway device anywhere cables are required to pass through fire-rated walls, floors or partitions.
2. Devices shall be installed in locations where required by the Contract Drawings, arranged individually or appropriately ganged.
3. Install the devices in strict accordance with the approved shop drawings and the equipment manufacturer’s recommendations.
4. Apply the factory supplied gasketing material (where required) prior to the installation of the wall plates.
5. Secure wall plates (where required) to devices per the equipment manufacturer’s

recommendations.

END OF SECTION 270500

SECTION 274100 - AUDIO VIDEO SYSTEMS

PART 1 - GENERAL REQUIREMENTS

1.1 SUMMARY

- A. These specifications and the associated TA series drawings describe the audio-video (AV) systems (hereafter referred to as the “Technical System”) requirements to be furnished and installed as a portion of the project scope of work.
- B. System is intended for support of scholastic drama and music productions and not for professional music concerts or other high-volume activities
- C. Work includes all such work indicated in all of the Contract Documents, including, but not limited to: Instructions to Bidders; Proposal Form; General Conditions; Supplementary General Conditions; Architectural, Structural, Communications, Fire Alarm and Electronic Safety and Security Drawings and Specifications; and Addenda.
- D. Work under this section of the specifications includes all labor, equipment, and installation as required to provide a complete technical system in compliance with the contract documents.
- E. Employ the services of a qualified structural engineer to review all overhead mounting and suspension details of the technical system equipment. All mounting and suspension schemes indicated on the drawings are shown for concept only. Submit shop drawings stamped by a structural engineer of all details and weights for review by the project’s Architect, Structural Engineer, and Design Consultant.
- F. The work in this section shall be coordinated with other work to determine installation scope for conduit, outlet boxes, junction boxes, pull boxes, terminal cabinets, 120-volt AC power circuits, and insulated ground cables required for the technical system.
 - 1. Provide related low-voltage “on/off” AC power control system wiring, low-voltage “on/off” control switches, and certain AC power/ground requirements internal to the equipment racks as specifically noted herein and/or on the drawings.

1.2 RELATED DOCUMENTS

- A. Drawings and general provisions of the Contract, including General and Supplementary Conditions and Division 1 Specification Sections, apply to this Section, as do the following:
 - 1. Division 27 Section “General Communications Requirements”.
 - 2. Division 27 Section “Common Work Results for Communications”
- B. All Category and fiber optic cabling and terminations shall adhere to the Division 27 Section “Telecommunications Requirements for Audio Video Systems”.
- C. This section is a parent section to all sections numbered 274101 thru 274199. Requirements found in this section shall apply to all child sections unless otherwise noted.

1.3 EXAMINATION OF SITE

- A. This project is an existing facility undergoing renovation.
- B. Prior to submitting a bid personally examine the site of the proposed work and verify the conditions which involve his work.
- C. By the act of submitting a bid, the contractor will be deemed to have made reasonable allowances for site examinations, site conditions, and included all costs in his proposal. Failure to verify these conditions will not be considered a basis for the granting of additional compensation.

1.4 MATERIAL AND WORKMANSHIP

- A. All equipment shall be new and in proper operating condition. All workmanship shall be of the finest quality by experienced installation technicians.
- B. Contact the Architect, in writing, regarding the selection of colors for all exposed equipment.
- C. In addition to a complete set of the system project drawings and specifications, maintain at the job site a complete set of manufacturer's original operation, instruction, installation, and service manuals for each equipment item, for reference.

1.5 ORDINANCE AND CODES

- A. Comply with all applicable national and local codes and ordinances and obtain all required permits.
- B. Contractor shall be responsible for any and all violations within the scope of this work.

1.6 DEFINITIONS

- A. Structured Cabling System – the physical infrastructure installed to support information technology/transport for voice and data applications, commonly referred to as a Telecommunications System. This includes, but is not limited to: Category cabling, terminations/blocks, modules, faceplates, etc., and optical fiber cabling, terminations, modules, etc
- B. Suspension System – A unique assembly of rated hardware elements and accessories required for overhead installation (and attachment to building structure) of loudspeakers and other technical system components. Elements of a suspension system may include: wire rope, shackles, eyebolts, chain, beam clamps, strut channel, etc.

1.7 QUALITY ASSURANCE

- A. Contractor General Qualifications:
 - 1. Compliance with the requirements of Division 1.
 - 2. Licensed to perform work of this type in the project jurisdiction.
 - 3. At least five (5) years of verifiable direct experience with the devices, equipment and systems of the type and scope specified herein.

4. Prior successful experience of projects of similar size, scope and type as outlined in the Construction Documents.
5. Active membership in the National Systems Contractors Association (NSCA).
6. Active membership in The Audiovisual and Integrated Experience Association (AVIXA).
7. Fully staffed and equipped maintenance and repair facility.
8. Factory-authorized dealer for the major components specified.

B. Contractor Personnel Qualifications:

1. Skilled workers thoroughly trained and experienced in the necessary crafts and completely familiar with the specified requirements and the methods needed for proper performance of the work in this section. The workers shall have at least three (3) years direct experience in similar work, evidence of which shall be verified in writing with appropriate references.
2. Supervisor with at least five (5) years direct experience in similar work. The supervisor shall be present for and in responsible charge of all work in the fabrication shop and on the project site during all phases of the installation and testing of the system(s). To assure continuity, this supervisor shall be the same individual throughout the execution of the work unless illness, loss of personnel, or other reasonable circumstances intervene. This person shall act as the Technical System Project manager and shall attend all scheduled project meetings.
 - a. Minimum of one full-time staff member who has attended technical system design and installation courses taught by Syn-Aud-Con in the past 10 years.
 - b. Minimum of one AVIXA CTS-I (Certified Technology Specialist - Installation) systems technician.
 - c. Minimum of one full-time staff member who has a minimum of three (3) years direct experience with and is factory-certified on the most recent version of the selected Digital Signal Processor (DSP) software and technology. This individual shall be responsible for the implementation of the DSP system including software. This individual shall be the same throughout the execution of the work unless illness, loss of personnel, or other reasonable circumstances intervene.
 - d. Minimum of one full-time staff member who has a minimum of three (3) years direct experience and is a factory certified Master Level Programmer on the most recent version of the AV control system software and technology. This individual shall be the same throughout the execution of the work unless illness or loss of personnel intervenes. A factory authorized independent programmer (i.e., Crestron Master CAIP) will also be accepted, providing the programmer meets the criteria identified in this paragraph.

- C. Provide additional information as required for review by the Owner's Representative, Architect, and Design Consultant to aid in proving acceptability.

1.8 SUBSTITUTIONS

- A. Substitutions of equipment/materials will be considered for approval in cases of discontinued or long lead-time items. The contractor shall bear the "burden of proof" for demonstrating substitute equipment/materials' equivalency and suitability including coordination as it relates to AC power, cooling, rack space, cable pathways, physical size/shape, etc.

- B. Requests for substitution of equipment/materials shall comply with Division 01 regarding the proposed substitute item(s), specifications, and front/rear views (if applicable).
- C. In the absence of Division 01 specifications on substitutions, information regarding substitution of equipment/materials shall be presented in writing to the Owner's Representative, Architect, and Design Consultant for review. This written request shall contain copies of complete manufacturer's literature regarding the proposed substitute item(s), specifications, and front/rear views (if applicable). The request shall also include detailed information regarding the reason for the proposed substitution.
- D. Submission of substitute equipment/materials (including any associated software) may be required for evaluation by the Design Consultant, at his discretion, prior to acceptance, and subject to evaluation fees. Contractor shall be responsible for the substituted equipment/materials and for all related shipping costs and evaluation fees.
- E. Replace any and all approved, installed substitute equipment/materials if an unforeseen defect appears, or if operational characteristics do not fulfill the design intent of the system.

1.9 SUBMITTALS

- A. Refer to requirements in Division 27 Section "General Communications Requirements".
- B. Include the following items:
 - 1. Bid
 - a. Contractor Qualifications
 - b. Personnel Qualifications
 - 2. Pre-Construction
 - a. Equipment List
 - b. Product substitutions, in accordance with Division 1 for discontinued products only
 - c. Manufacturers' Cut-sheets
 - 1) Minor pieces of equipment that are not visible and inconsequential to system operation may be included on Equipment List and no cut-sheet is required.
 - d. Signal Flow Shop Drawings – One-line diagrams indicating full intended system configuration. Any generic diagrams found within the Construction Documents shall be drawn to specific requirements. Alterations from basis of design found within the Construction Documents shall be reflected and identified.
 - e. DSP Signal Flow - DSP signal flow configuration (submitted no less than three months to system first use).
 - f. Millwork Shop Drawings - Sound console and mobile cart millwork details, and related equipment and panel layout.
 - g. AV Control System - AV control system panel/screen layouts suitable for the Owner's Representative to understand the operation and flow (submitted no less than five months prior to system first use).

- h. Schedule
 - 1) Off-site: touch screen layouts, DSP configuration
 - 2) On-site under scope: rack installation, loudspeaker installation
 - 3) On-site other scope: complete and securable millwork/control booth
 - 4) Include quiet time on-site for sound system equalization and setup.
- i. AV Pathways and Cabling – Follow requirements of Division 27 Section “Common Work Results for Communications”.
- j. Structural Details
 - 1) No Suspended device shall be installed prior to the final approval of Structural Detail Submittals by the Consultant.
 - 2) For Suspended equipment provide detailed, dimensioned drawings of each Suspension hardware assembly. Also indicate location relative to structure, location relative to other component(s) (Technical System or otherwise), configuration of suspended components, attachment to structure, suspension method, and calculations.
 - a) Calculations shall include weights of Technical System equipment including suspension hardware, and details of all suspension hardware including: manufacturer(s), part number(s) and pertinent technical information (i.e., Working Load Limit) of each part including nuts, bolts, and other accessories. All weight bearing hardware must be traceable, load rated, and domestically manufactured. All welds must be certified.
 - 3) Prior to submission, these drawings must be approved and signed/sealed by a structural engineer licensed for the location of the project. The following guidelines are applicable:
 - a) Contractors participating in the Suspension of Technical System components shall conform to industry best practice standards as set forth in:
 - i) “Basic Principles for Suspending Loudspeaker Systems” (JBL Professional Technical Note Volume 1, Number 14); and
 - ii) ANSI E1.6-2 -2013 (Entertainment Technology – Design, Inspection, and Maintenance of Electric Chain Hoists for the Entertainment Industry); and
 - iii) ANSI E1.6-3- 2012 (Selection and Use of Serially Manufactured Chain Hoists in the Entertainment Industry).
 - b) All Suspended loudspeakers shall conform to ANSI E1.8-2012 (Entertainment Technology—Loudspeaker Enclosures Intended for Overhead Suspension—Classification, Manufacture and Structural Testing).
- k. Equipment Rack Shop Drawings - Equipment rack front elevation for each rack showing equipment and panel layout.
- l. Panel, Patch Panel, and Plate Shop Drawings - All panel, patch panel, and plate layouts indicating locations of connectors, engraving, nomenclature, panel material, and finish.

Include Structured Cabling Work required by the technical system.

- m. Refer to child sections for additional requirements.

3. Project Completion

- a. Contractor's Testing Documentation Package – Provide preliminary results of system testing as described in Part 3 of this section for review prior to final acceptance. Include final results with Closeout Documentation.
- b. Refer to Division 27 Section "General Communications Requirements" and the Record Drawings and Operation and Maintenance Data sub-sections in Part 3 of this section for requirements.
- c. Refer to child sections for additional requirements.

1.10 ELECTRONIC FILE SHARING

- A. Refer to Division 27 Section "General Communications Requirements" for information on obtaining electronic versions of the construction drawings.

1.11 PROTECTION OF WORK

- A. Protect all work, materials and equipment from damage due to any cause. Provide for the safety and new condition of the equipment and materials until final acceptance by the Owner's Representative. Replace all damaged or defective materials and/or equipment as directed by the Architect or Design Consultant.
- B. Equipment racks, cabling racks, junction boxes, termination boxes, and other exposed equipment shall be kept covered and protected from airborne contaminants. Clean all debris from the equipment room(s)/location(s) and control areas, and clean all equipment and the interior rack floor, prior to system final acceptance activities.

1.12 EXISTING EQUIPMENT

- A. Certain existing technical system equipment shall be re-used with the new technical system as indicated on the drawings and in these specifications. Provide any equipment not specifically noted as "existing".
- B. Obtain this equipment from the Owner's Representative in a timely manner as required to coordinate with the project schedule. Verify all model numbers, quantities, sizes, and connector types as necessary to coordinate with system requirements. The Owner's Representative may elect to substitute other equipment in lieu of that listed prior to the submission of shop drawings.
- C. Examine the equipment and perform normal operational checks to verify that the equipment is in good condition and is operating normally. Should any equipment defects be found (physical, electrical, or otherwise), identify, in writing to the Owner's Representative: a) defects found; and b) the estimated cost of any proposed repairs versus cost of replacement.
- D. Where required for rack-mounting, furnish rack-mounting hardware or shelf for equipment not already having rack-mounting flanges. Also furnish security covers for existing equipment where such covers are required per the specifications.
- E. Fully integrate the equipment with the technical system and provide all necessary signal connections and

programming.

- F. Proper operation and maintenance of such existing equipment remains the responsibility of the Owner's Representative.

1.13 EXISTING WIRING -REMOVAL

- A. Comply with NEC (National Electrical Code) requirements regarding removal of all existing wiring that is not re-used with the system(s) defined herein.

1.14 TEMPORARY TECHNICAL SYSTEM

- A. Provide and operate a temporary technical system of reasonably equivalent function as determined by the Design Consultant if the work in this section, as a failure of the contractor, is incomplete or found not in conformance with the contract documents. The temporary system shall remain in use until acceptance of the permanent system.

1.15 WARRANTY

- A. Warrant all work executed under this contract, including all in-shop and onsite material, parts and labor, for a period of twelve months after the date of final acceptance.
 - 1. Existing or any other Owner-furnished equipment shall not be included in this warranty.
 - 2. For equipment that has an advertised manufacturer's warranty longer than 12 months, include end date of warranty period.
- B. The warranty services are limited to normal business hours, unless additional agreements are made between the Owner's Representative and the contractor.
- C. Warranty work relating to technically complex equipment and/or programming such as for codecs, digital signal processing, control systems, and video projectors shall be performed by a factory authorized technician.
- D. Damage to the system resultant from improper use or adjustment by others, negligence, acts of nature, or other causes which are beyond the contractor's control shall be excluded from the warranty.
- E. Visit the job two weeks prior to the end of the warranty period to check all equipment for proper system operation. Any defective equipment found shall be replaced or repaired under the terms of the system warranty.
- F. Update Record Drawings and Operation and Maintenance Data to reflect work done during Warranty period and provide the updates to the Owner's Representative and Design Consultant.
- G. Refer to General Conditions for additional requirements.

PART 2 - PRODUCTS

2.1 GENERAL

- A. Unless otherwise designated, provide all of one type of equipment from one manufacturer; for example, microphones of one type by one manufacturer, data switches of one type by one manufacturer, cabling of one type by one manufacturer, or loudspeakers of one type by one manufacturer.
- B. Equipment and wiring shown on the drawings represents the basis of design. Ensure similar or better performance is achieved by the use of equipment other than that shown.
- C. All major components of technical system equipment shall be provided and installed by a qualified contractor as outlined in Part 1 of this section.
- D. All equipment shall be new and of professional quality.
- E. Some items listed in these specifications are custom-made products. Ensure when pricing and ordering equipment that the exact part number called out is used. If there is a discrepancy, contact the Design Consultant for clarification.
- F. Each software programmable device furnished (i.e. Digital Signal Processor, control system, etc.) shall include most recent software and appropriate computer interface (wired cable or wireless). Cable, software, source (uncompiled) code and all related aspects of all software-controlled equipment shall become the property of the Owner and will be furnished as a portion of the Operation & Maintenance (O&M) Data manuals (see Operation & Maintenance Manuals near the end of Part 3).
- G. The quantities of each item of portable or mobile equipment (and other portable or loose accessories), as well as those items associated with Alternates, are indicated in parenthesis. Such equipment is intended to be shared between rooms having technical systems, except where noted for use in one specific room.

2.2 ETHERNET SWITCHES & ACCESSORIES

- A. General Requirements
 - 1. Ethernet switches shall be as recommended by the manufacturer(s) of the connected technical system equipment. These devices shall also be coordinated with the Owner's Representative's IT department to maintain common products (where possible). Each shall be labeled as shown on the technical system drawings and as required to match the Owner's Representative's IT labeling standard.
 - 2. Contractor shall be responsible for the selection of product(s) that are approved for use with all systems connected to the switch(es). Products listed in this portion of the specifications are representative at the time of design – furnish the most recent approved product.
 - 3. Ethernet switches shall have IPv4 and IPv6 routing, multicast routing, advanced quality of service (QoS), and security features in hardware. Disabling of power saving and other blocking features shall be available for proper signal traffic. SFP uplink ports are required.
 - 4. Ethernet switches shall be provided with all licensing requirements, product activation requirements, etc. for proper operation.
 - 5. Ethernet switches shall be configured for proper operation of the system. Configuration shall comply with Owner's network standards.

6. The use of “Small Business” type switches and the like are not permitted.

B. Protocol Hardware Requirements

1. Ethernet Control

- a. Layer 2, minimum
- b. 10/100baseT ports, minimum
- c. Refer to primary control system manufacturer for network requirements.

2. Standards Based Protocols

- a. AES67
- b. AVB
 - 1) Must be certified product per AVNU.org list of certified products.
 - 2) For Biamp systems, refer to “List of AVB-capable Ethernet switches” support page at support.biamp.com.
 - 3) Refer to Switch Manufacturer’s product data for requirements related to addition of “feature packs” or similar to enable AVB protocol.
- c. Dante
 - 1) Layer 2, minimum
 - 2) 10/100/1000baseT ports, minimum
 - 3) QoS
 - 4) Refer to Audinate website “Networks and Switches” Support page for full requirements.
- d. HDbaseT-IP
- e. SDVoE

3. Proprietary Protocols

- a. QLAN
 - 1) 1 Gbps ports, non-blocking
 - 2) Layer 3
 - 3) IGMP Snooping

C. Minimum Hardware Requirements:

1. Layer 2: product meeting Protocol Hardware Requirements, only serving one protocol type, and from the following manufacturers:
 - a. Cisco
 - b. Extreme Networks
 - c. HP Enterprise
 2. Layer 3:
 - a. Cisco
 - b. Extreme Networks
 - c. HP Enterprise
 3. AVB: product meeting Protocol Hardware Requirements from the following manufacturers:
 - a. Cisco; or
 - b. Extreme Networks; or
 - c. Netgear; or
 - d. Packedge.
 4. Fanless: product meeting Protocol Hardware Requirements for use in enclosed equipment racks such as millwork or credenzas:
 - a. Cisco 2960-L Series or 3560-CX Series
 - b. Extreme Networks
 - c. HP Enterprise
- D. Ethernet Switches shall be provided with the following minimum characteristics required as shown on the signal flows:
1. Key to product identification: Example(**)(M)(P)(1G)(R)(-L3)(-AVB):
 - a. ** = minimum quantity of ports
 - b. (M) = managed switch (no symbol = unmanaged)
 - c. (P) = PoE (P+ = PoE+) (no symbol = non-PoE)
 - d. (*G) = 1 GB/s or 10 GB/s-capable ports as shown (no symbol = minimum 100 MB/s-capable ports)
 - e. (R) = rack mount (no symbol = optional if not included)
 - f. (-L*) = minimum layer requirements (L2 = minimum layer 2 enterprise level feature set; L3 = minimum layer 3 enterprise level feature set)

g. (-AVB) = AVB certified (no symbol = AVB capability not required)

E. PoE Injector, 1 port Power over Ethernet injector:

1. Crestron PWE-4803RU; or
2. D-Link DWL-P200; or
3. SonicWALL PoE Injector; or
4. Approved equal.

2.3 DATA PATCH PANELS & ACCESSORIES

- A. Data Patch Panels are acceptable for use in Ethernet, audio network, AVLAN, and digital multimedia network applications as required to provide a complete technical system.
- B. All Category and Fiber Optic cabling (of the acceptable applications listed above) entering a technical system rack shall be terminated to a Data Patch Panel. Rack inter- and intra-connect cabling utilizing factory-terminated cable assemblies are not required to pass thru a Data Patch Panel unless shown otherwise.
- C. Data Patch Panels shall be labeled per specification part 3 of this section.
- D. Category Cabling Patch Panels –
 1. Refer to Division 27 Section “Telecommunications Requirements for Audio Video Systems” for product information and additional installation requirements.
- E. Fiber Optic Patch Panels & Enclosures –
 1. Refer to Division 27 Section “Telecommunications Requirements for Audio Video Systems” for product information and additional installation requirements.
- F. Cable Management – 19” wide horizontal patch cable management system, 1 rack unit, with pass-through opening to allow patch cables access to rear of rack (one required per 24 port patch panel / switch):
 1. Chatsworth Velocity 13930-701
 2. Cooper B-Line RCM+ SB87019S1
 3. Panduit NetManager NMF1
 4. Or approved equal

2.4 A/V CONTROL SYSTEM – GENERAL PROGRAMMING REQUIREMENTS

- A. Touch screen control interfaces shall follow the guidelines outlined in the “Dashboard for Controls” documents created on behalf of AVIXA International. Reference the Design Guide, Design Reference, and Integrators Guide for this project. Documents are available for download on the AVIXA web site.
- B. Contractor shall be responsible for complete configuration of the control system features including touch

screen layouts, colors, appearance, operation, and coordination with systems external to the Technical System.

- C. Participate in planning meeting(s) (web/phone) with Design Consultant and Owner's Representative to review programming concepts and requirements before commencement of work.
- D. Panel layout and navigational flow concepts shall be developed during planning meeting(s) with Design Consultant and Owner's Representative.
- E. Refer to submittal requirements for additional information.
- F. This specification describes the initial touch screen programming concepts and requirements. Account for four (4) distinct changes for revisions requested by the Owner's Representative after the system is substantially complete.
- G. Touch screen and keypad overall user interfaces shall comply with the following minimum requirements:
 - 1. A common theme shall be employed and used with consistency throughout the layouts. Theme shall be discussed with the Owner's Representative. The Owner's standard theme template shall be used if available.
 - 2. Where Owner logos or colors are used, Owner branding guidelines shall be followed. Trademarks shall be used appropriately. Official graphical representations (logos, word marks, logotypes, etc.) may not be altered. Owner colors shall utilize official and exact color (Pantone, CMYK, RGB, hex, etc.) as provided by the Owner, visual matching is not allowed. Content shall be obtained from an official and authorized source, e.g., the use of content from Google images is not appropriate. Owner branding is encouraged where appropriate; however, proper use and compliance remains the responsibility of the Contractor.
 - 3. The use of a password hierarchy shall be employed as directed by the Owner's Representative as they deem appropriate.
 - 4. Power ON/OFF sequence shall control all applicable devices. Sequence time shall be the required time for all controlled devices to cycle. Projector lamp warm-up and cool-down period shall be taken into account. Shutdown shall utilize two-step verification.
 - 5. Animated activity indicators (spinning ring, progress bar, etc.) shall be utilized to provide visual feedback while the system is processing tasks in the background. This will prohibit multiple button presses by the user and show feedback that the control system is processing the request. Relevant text shall be utilized where appropriate, e.g., "Please wait while the system shuts down."
 - 6. Source selection shall be available for all devices. Sources shall be laid out and grouped in a logical manner. A 'blank source' or 'image blanking' feature shall be utilized to result in no image being displayed.
 - 7. Button presses shall show instant visual feedback that they have been engaged and shall accurately reflect the response received from the device being controlled.
 - 8. Current system status shall be visible at all times and be consistent across all adjoined screens. Buttons shall show current status (engaged or disengaged) via color, illumination, outline, greyscale, etc. as relevant. Sliders and level indicators shall show current and true system status (i.e. show true level based on system feedback, not status based on last touch screen input) via color, knob location, percentage, etc. as relevant.
 - 9. Volume control of wired microphones, wireless microphones, and/or AV system program volume

levels shall be discrete and shall be properly interfaced with the DSP (where applicable). The use of a master volume control is prohibited.

10. Where applicable, show the current operation mode. For example, in the case where two rooms combine/separate, the word “Combined” or “Separated” shall be displayed on each applicable screen.

2.5 CABLE - BULK

- A. The products in this section have been approved for use in the project as necessary to facilitate a complete and working system. Inclusion in this section does not indicate a requirement for use.
- B. Product must be procured from the original cable manufacturer.
- C. AWG wire sizes indicated herein or on the drawings are the minimum size conductors required. Larger size conductors (i.e., smaller AWG number) are permitted assuming no impact on the project will occur (such as the resulting need for larger or additional conduit, cable trays, chases, etc.) to accommodate such cable.
- D. Where cable is run exposed (such as in ceiling plenums, cable trays, chases, or below accessible floors):
 1. Verify which locations do and do not require plenum-rated cable.
 2. Furnish the appropriate cable type.
 3. Obtain written authorization from the Architect (or the Architect’s designated Engineer) in this regard.
- E. Category cabling:
 1. Refer to Division 27 Section “Telecommunications Requirements for Audio Video Systems” for product information and additional installation requirements.
- F. Fiber Optic cabling:
 1. Refer to Division 27 Section “Telecommunications Requirements for Audio Video Systems” for product information and additional installation requirements.
- G. Twisted Pair – Shielded: Twisted pair, shielded 22 AWG cable; interior rated 2 conductor cable with drain wire suitable for microphone, line, or production intercom level circuits:
 1. Communications plenum rated cable (CMP) is suitable for use in all environments including environmental air plenums as defined per NEC Article 800.
 - a. The use of performance equivalent substituted cables of lesser type is permitted at the Contractor’s discretion where allowable by NEC Article 800, local codes, and the connected equipment manufacturer’s listed requirements.
 - b. Performance equivalence to the below specified products shall be determined by the cable manufacturer’s listed product equivalents provided in tables and cut-sheets.
 2. Tinned copper cables are required in locations subject to corrosion, such as natatoriums.
 3. 22 AWG/CMP: 22 AWG Communications Plenum rated bare copper conductor cable:

- a. Belden 9451P or 6500FC; or
 - b. Clark Wire SPA22GSP; or
 - c. Gepco IP222AL or 61801HS; or
 - d. West Penn 25291B.
4. 22 AWG/CMR: 22 AWG Communications Riser rated bare copper conductor cable:
- a. Belden 8451 or 9451 or 5500FE; or
 - b. Clark Wire SPA22GS; or
 - c. Gepco IR222AL or 61801 or 61801EZ; or
 - d. West Penn 291 or 452.
5. 22 AWG/CMP/MC: 22 AWG Communications Plenum rated bare copper multi-conductor cable, individually shielded pairs, color coded (not for interconnection within equipment racks):
- a. 12 pair:
 - 1) Clark Wire 22EPS12P; or
 - 2) Gepco 6612HS
 - b. 8 pair:
 - 1) Clark Wire 22EPS8P; or
 - 2) Gepco 6608HS
 - c. 6 pair:
 - 1) Belden 6545PA; or
 - 2) Clark Wire 22EPS6P; or
 - 3) Gepco 6606HS.
 - d. 4 pair:
 - 1) Clark Wire 22EPS4P; or
 - 2) Gepco 6604HS.
 - e. 3 pair:
 - 1) Belden 6542PA.
 - f. 2 pair:
 - 1) Belden 6541PA or 9451DP.

6. 22 AWG/CMR/MC: 22 AWG Communications Riser rated bare copper multi-conductor cable, individually shielded pairs, color coded (not for interconnection within equipment racks):
 - a. 24 pair:
 - 1) Belden 1821R; or
 - 2) Clark Wire 724; or
 - 3) West Penn WP45424.
 - b. 16 pair:
 - 1) Belden 1819R; or
 - 2) Clark Wire 716; or
 - 3) Gepco GA61816GFC; or
 - 4) West Penn WP45416.
 - c. 12 pair:
 - 1) Belden 1818R or 9768, or
 - 2) Clark Wire 712; or
 - 3) Gepco GA61812GFC; or
 - 4) West Penn D434 or WP45412.
 - d. 8 pair:
 - 1) Belden 18710R; or
 - 2) Clark Wire 708; or
 - 3) Gepco GA61808GFC; or
 - 4) West Penn WP4548.
 - e. 6 pair:
 - 1) Belden 1816R or 8778; or
 - 2) Clark Wire 706; or
 - 3) Gepco GA61804GFC; or
 - 4) West Penn D432 or WP4546.
 - f. 4 pair:
 - 1) Belden 1815R; or

- 2) Clark Wire 704; or
 - 3) Gepco GA61804GFC.
- g. 3 pair:
- 1) Belden 8777; or
 - 2) West Penn D431.
- h. 2 pair:
- 1) Belden 9451D; or
 - 2) Clark Wire RS22G2; or
 - 3) Gepco D61801EZGF; or
 - 4) West Penn 77510.
- H. Twisted Pair – Unshielded: Twisted pair, unshielded, 2-conductor interior installation loudspeaker cable:
1. Class 3 remote-control, signaling, and power-limited plenum rated cable (CL3P) is suitable for use in all environments including environmental air plenums as defined per NEC Article 725.
 - a. The use of performance equivalent substituted cables of lesser type is permitted at the Contractor's discretion where allowable by NEC Article 725, local codes, and the connected equipment manufacturer's listed requirements.
 - b. Performance equivalence to the below specified products shall be determined by the cable manufacturer's listed product equivalents provided in tables and cut-sheets.
 - c. Wire gauge shall not be reduced to gain a higher cable rating.
 2. Tinned copper cables are required in locations subject to corrosion, such as natatoriums.
 3. ** AWG/CL3P: As listed AWG Class 3 Plenum rated bare copper conductor cable:
 - a. Belden 1862A or 6200UE (16 AWG), 6300UE (18 AWG); or
 - b. Gepco IP122BA19 (12 AWG), IP142BA19 (14 AWG), IP162BA19 (16 AWG), IP182BA7 (18 AWG); or
 - c. West Penn 25210 (10 AWG), 25227B (12 AWG), 25226B (14 AWG), 25225B (16 AWG), 25224B (18 AWG).
 4. ** AWG/CL2P: As listed AWG Class 2 Plenum rated bare copper conductor cable:
 - a. Belden 6T00UP (10 AWG), 1860A or 6000UE (12 AWG), 1861A or 6100UE (14 AWG), 1863A (18 AWG); or
 - b. Clark Wire CW1202P (12 AWG), CW1402P (14 AWG), CW1602P (16 AWG), CW1802P (18 AWG).
 5. ** AWG/CL3R: As listed AWG Class 3 Riser rated bare copper conductor cable:

- a. Belden 5000UE (12 AWG), 5100UE (14 AWG), 5200UE (16 AWG), 5300UE (18 AWG);
or
 - b. Clark Wire CW1202HS (12 AWG), CW1402HS (14 AWG); or
 - c. Gepco IR122BA19 (12 AWG), IR142BA19 (14 AWG), IR162BA19 (16 AWG),
IR182BA7 (18 AWG); or
 - d. West Penn 227 (12 AWG), 226 (14 AWG), 225 (16 AWG), 224 (18 AWG).
6. ** AWG/CL2R: As listed AWG Class 2 Riser rated bare copper conductor cable:
- a. Clark Wire CW1202 (12 AWG), CW1402 (14 AWG), CW1602 (16 AWG), CW1802 (18
AWG).
7. ** AWG/CL3: As listed AWG Class 3 rated bare copper conductor cable:
- a. Belden 1313A (10 AWG), 1311A (12 AWG), 1309A (14 AWG), 1307A (16 AWG); or
 - b. Gepco 122HBW (12 AWG), 142HBW (14 AWG).
8. ** AWG/CL2: As listed AWG Class 2 rated bare copper conductor cable:
- a. Belden 5T00UP (10 AWG); or
 - b. West Penn HA210 (10 AWG).
- I. Twisted Pair – Unshielded – EXT: Twisted pair, unshielded exterior use cable; 2-conductor loudspeaker,
sunlight resistant, direct burial:
- 1. Exterior cable shall be listed as suitable for use in Class 3 General Purpose indoor environments as
defined per NEC Article 725.
 - 2. ** AWG/EXT: As listed AWG indoor/outdoor rated bare copper conductor cable:
 - a. Belden 8808WB (8 AWG), 1313A (10 AWG), 1311A (12 AWG), 1309A (14 AWG),
1307A (16 AWG); or
 - b. Clark Wire CW1002DB (10 AWG), CW1202DB (12 AWG), CW1402DB (14 AWG),
CW1602DB (16 AWG); or
 - c. Gepco SSU102P (10 AWG), SSUB122 (12 AWG), SSUB142 (14 AWG), SSUB162 (16
AWG); or
 - d. West Penn C208 (8 AWG), C210 (10 AWG), AQ227 (12 AWG), AQ226 (14 AWG),
AQ225 (16 AWG).
- J. Single conductor – Unshielded: Single conductor, unshielded cable:
- 1. LS Cable, loudspeaker cable for use when conduit size is limited:
 - a. THHN or THWN single conductor stranded copper. Utilize the maximum available color
range.
- K. RG-58: Single 50-ohm coax, RG-58/U radio frequency cable:

1. RG-58/NP: Non-plenum cable installed in conduit, equipment racks, or other non-plenum spaces:
 - a. Belden 7806R; or
 - b. Clark Wire CV5058; or
 - c. West Penn 812.
 2. RG-58/P: Plenum rated cable:
 - a. Belden 82240 or 88240; or
 - b. Clark Wire CV5058P; or
 - c. West Penn 25812.
- L. RG-8: Single 50-ohm coax, RG-8X and RG-8/U radio frequency cable:
1. RG-8X/NP: Non-plenum cable installed in conduit, equipment racks, or other non-plenum spaces:
 - a. Belden 7808R or 9258; or
 - b. Clark Wire CV5008X; or
 - c. Gepco V5020; or
 - d. West Penn 807.
 2. RG-8X/P: Plenum rated cable:
 - a. West Penn 25810.
 3. RG-8/U/NP: Non-plenum cable installed in conduit, equipment racks, or other non-plenum spaces:
 - a. Belden 9913; or
 - b. Clark Wire RF50LL; or
 - c. West Penn 810.
 4. RG-8/U/P: Plenum rated cable:
 - a. Belden 89913; or
 - b. Clark Wire RF50LLP; or
 - c. West Penn 25812.
- M. RG-213: Single 50-ohm coax, RG-213/U radio frequency cable:
1. RG-213/NP: Non-plenum cable installed in conduit, equipment racks, or other non-plenum spaces:
 - a. Belden 8267; or
 - b. Clark Wire CV50213.

- N. Control cable, power and control in one jacket, one unshielded 18 WG pair, one shielded 22 AWG pair:
 - 1. Control cable - NP, not plenum rated:
 - a. Belden 1502R or Gepco 18/22AXL; or
 - b. Clark Wire ULK2218; or
 - c. Crestron CRESNET-NP; or
 - d. West Penn 77350.
 - 2. Control cable - P, plenum rated:
 - a. Belden 1502P or Gepco 18/22AXLP; or
 - b. Clark Wire ULK2218P; or
 - c. Crestron CRESNET-P; or
 - d. West Penn D25350.

- O. RS-232: Low capacitance computer cable for EIA RS-232/422, 24 AWG, 4-conductor, shielded, minimum conductor-to-conductor capacitance: 22pF/ft, PVC jacket:
 - 1. RS-232/NP: Non-plenum cable installed in conduit, equipment racks, or other non-plenum spaces:
 - a. Belden 8102; or
 - b. Clark Wire SMP2404.
 - 2. RS-232/P: Plenum rated cable:
 - a. Belden 88102; or
 - b. Clark Wire SMP2404P.

2.6 CABLES – FACTORY TERMINATED – INSTALLED

- A. The products in this section have been approved for use in the project as necessary to facilitate a complete and working system. Inclusion in this subsection does not indicate a requirement for use.
- B. Factory terminated cable assemblies specified in this subsection are only permitted for use within racks or between devices external to racks. Permitted for rack inter-connect when racks are in close proximity (same room) and may pass thru conduit if necessary in this situation. Not permitted for use in conduit unless specifically noted as such.
- C. Factory terminated cable assemblies shall be the minimum length needed to accomplish the connection. Portable cable assemblies are specified in Division 27 Section “Audio Video Systems Equipment” and are required to be furnished in addition to those required for system installation.
- D. All cable assemblies must be factory tested and certified.
- E. Category cabling:

1. Refer to Division 27 Section "Telecommunications Requirements for Audio Video Systems" for product information and additional installation requirements.
- F. Fiber Optic cabling:
1. Refer to Division 27 Section "Telecommunications Requirements for Audio Video Systems" for product information and additional installation requirements.
- G. USB, Type B male (device = square) to Type A male (computer = flat) or Type A male to Type A male USB 2.0 compliant, Acceptable lengths: 1'-25':
1. Comprehensive; or
 2. Extron; or
 3. Approved Equal.

2.7 CONNECTORS

- A. The products in this section have been approved for use in the project as necessary to facilitate a complete and working system. Inclusion in this section does not indicate a requirement for use.
- B. All XLR receptacles located outdoors, in boxes that are located outdoors, in natatoriums, or in areas where moisture or other corrosive materials are present shall have gold plated contact pins.
- C. XLR Cable Connector, cable mounted connector for line-level, microphone level, and intercom circuits:
1. Amphenol AC series; or
 2. Neutrik X-series; or
 3. Switchcraft E Series Q-G.
- D. XLR Panel Connector, panel mounted audio connector for line-level, microphone level, and intercom circuits, color shall match plate color where possible:
1. Amphenol AC "DZ" series; or
 2. Neutrik D-Series; or
 3. Switchcraft standard AAA Series Q-G with metal handle.
- E. XLR Combo Connector, female XLR and 1/4" TRS receptacle in one chassis-mount connector:
1. Neutrik NCJ6FI-S.
- F. 1/4" TRS Cable Connector, three-conductor (Tip Ring Sleeve) connector with a metal barrel and solder lugs:
1. Amphenol TS3PN; or
 2. Canare F-16; or
 3. Neutrik NP3C; or

4. Switchcraft 267.
- G. 1/4" TS Cable Connector, two-conductor (Tip Sleeve) connector with a metal barrel and solder lugs:
1. Amphenol TM2PN; or
 2. Canare F-15 plug; or
 3. Neutrik NP2C plugs; or
 4. Switchcraft 250.
- H. 1/4" TRS Panel Connector, three-conductor (Tip Ring Sleeve) connector with the sleeve contact isolated from the panel or plate to which it is mounted:
1. Neutrik NJ3FP6C; or
 2. Switchcraft E112BL.
- I. 1/8" TRS Cable Connector, 1/8" (3.5mm) three-conductor mini-plugs which have a metal barrel and solder lugs:
1. Amphenol KS3P; or
 2. Canare F-12; or
 3. Neutrik NTP3RC; or
 4. Switchcraft 35HDNN plug.
- J. Locking LS Cable Connector, twist-lock cable mount male loudspeaker connector, minimum 2-two conductors. Coordinate connector with associated intended panel mount connector, including those on loudspeakers:
1. Amphenol SP-2-FN (two conductor); or
 2. Neutrik speakON NL2FC (two conductor); or
 3. Amphenol SP-4-FN (four conductor); or
 4. Neutrik speakON NL4FC (four conductor); or
 5. Neutrik speakON NL8FC (eight conductor).
- K. Locking LS Panel Receptacle, twist-lock chassis mount female loudspeaker connector, minimum two conductors. Coordinate receptacle with associated intended cable connector:
1. Amphenol SP-2-MD (two conductor); or
 2. Neutrik speakON NL2MP (two conductor); or
 3. Amphenol SP-4-MD (four conductor); or
 4. Neutrik speakON NL4MP. Male connector (four conductor); or

5. Neutrik speakON NL8MPR-BAG (eight conductor)
- L. RJ45 Panel (Faceplate) Connector-6, data connector rated for shielded Category 6 cable:
1. Neutrik etherCON NE8FDY-C6* with SCDX cover
- *Division 27 “Telecommunications Requirements for Audio Video Systems” Contractor shall terminate cable onto etherCON connector installed in custom faceplate.
- M. BNC Cable Connector, 75-ohm BNC, compression fitting for coaxial cable furnished:
1. Liberty CM-RG-BNC series; or
 2. West Penn CN-CS-BNC and CN-FS-BNC series.
- N. BNC Panel Connector, 75-ohm BNC, pass-through, D-style mounting:
1. Neutrik NBB75DFI; or
 2. Approved Equal.
- O. Terminator, RF or SDI terminator plug:
1. Extron T-BNC series; or
 2. Pomona 3840 series; or
 3. Trompeter TNA series.
- P. Captive Screw Terminal Block, modular terminal blocks for mounting on DIN rails:
1. Entrelec Screw Clamp series; or
 2. Approved Equal.

2.8 EQUIPMENT RACKS

- A. Furnish complete equipment racks including all top, bottom, and sides as necessary.
- B. Furnish all necessary accessories including ganging hardware, blank plates (to fill all unoccupied space), vent panels (as applicable), shelves, security covers, mounting screws, trim kits, lacing bars, cable management, leveling feet, casters, etc. to provide a complete solution which complies with “best practice” guidelines.
1. Full-solution accessories are not detailed in this specification. They shall be provided as needed and shall be approved by the manufacturer for use with the intended rack series (i.e. Middle Atlantic casters must be used with a Middle Atlantic rack).
- C. Furnish all required components for a complete thermal management solution within each location to ensure enclosure interior temperature does not exceed manufacturer’s recommended operating temperatures.
1. Rack fans shall be quiet, such as the Middle Atlantic QFAN.

2. Thermostatic fan control shall be utilized where available.
- D. Furnish all required components for a complete rack ground isolation solution.
1. Racks shall be isolated from the floor by the use of isolated leveling feet (such as Middle Atlantic LF-ISO) or an isolation pad/system (such as Middle Atlantic ISO-1).
- E. Equipment racks and all associated blank panels located in equipment rooms shall be factory finished semi-gloss black. Equipment racks and associated blank panels located in control booths or other visible locations shall be factory-finished color as selected by the Architect.
- F. Furnish locking storage drawers, hinged security covers, and racks with locking doors all keyed alike. Furnish four keys total.
- G. Equipment rack specification indicates the system basis of design. Verify equipment layout, rack size, and number of equipment racks required for equipment furnished.
- H. Floor Rack:
1. Open Sides, open-rack style with open sides, rear locking door, minimum 44RU height, minimum 27" depth. Furnish one side panel at each end of each row of equipment racks:
 - a. Lowell LGR-4427; or
 - b. Middle Atlantic Products BGR-4527; or
 - c. Middle Atlantic Products WRK-44-27; or
 - d. Chief NG1F4428.
 2. Open Sides – XD, open-rack style with open sides, rear locking door, minimum 44RU height, minimum 32" extra deep. Furnish one side panel at each end of each row of equipment racks:
 - a. Lowell LGR-4432; or
 - b. Middle Atlantic Products BGR-4532; or
 - c. Middle Atlantic Products WRK-44-32; or
 - d. Chief NG1F4433.
- I. Desktop Rack – SA, stand-alone rack for locating on top of or beneath a desk or counter, laminate surface, minimum depth 18":
1. Middle Atlantic Products BRKxx series; or
 2. Chief ER-xx-18 series.

2.9 EQUIPMENT RACK ACCESSORIES

- A. The following equipment rack accessories shall be provided as appropriate to provide a fully functional installation.
- B. Equipment rack accessories located in equipment rooms shall be factory finished semi-gloss black.

Equipment rack accessories located in control booths or other visible locations shall be factory-finished color as selected by the Architect.

- C. Logo rack panel, single vertical rack space, labeled with contact information for the contractor and Design Consultant. Panel specified is custom and already has the information for the Design Consultant; the contractor shall coordinate their logo/information with the panel manufacturer (shop drawing required). One required to be installed at the top of each bank of equipment racks:

1. Liberty Wire and Cable model HEI-RHIM-TEMPLATE.

- D. Storage Drawer:

1. 3, rack drawer, 5.25" high (3RU), approximately 16" deep, color to match adjacent rack-mounting panels (qty: 1 per amplifier equipment rack):

- a. Atlas Sound SD3-14; or
- b. Middle Atlantic D3; or
- c. Chief SDR-3.

- E. Rack Shelf:

1. 2, utility rack shelf, 3.5" high, approximately 16" deep, color to match adjacent rack-mounting panels (qty: 1 per amplifier equipment rack)::

- a. Atlas Sound SH2-15; or
- b. Middle Atlantic U2; or
- c. Chief UTS-2.

2.10 AC POWER

- A. General

1. A complete AC power connection solution for each equipment rack and cabinet is required.
2. Provide spare NEMA 5-15R or 5-20R outlets (single duplex receptacle) for temporary equipment (beyond that required for connected equipment, rack fan, etc.). These outlets shall be fed from an un-switched "Normal" power circuit.
 - a. For racks 16 RU or less: two spare outlets (minimum)
 - b. For racks greater than 16 RU: four spare outlets (minimum)
3. All power strips shall maintain integrity of system grounding requirements.
4. All equipment shall be connected such that maximum rated performance can be obtained without exceeding the AC circuit load capacity.
5. Coordinate with Electrical drawings and Division 26 specifications. Where outlets are provided under this section as a portion of power strips or power distribution units, receptacle types and colors shall match the supplied AC power circuit.

6. Comply with all NEC requirements, including separation of loads classified as Life Safety from Normal loads via an independent Vertical / Horizontal Power Strip, PDU, and/or UPS.

B. Uninterruptable Power Supply Requirements

1. UPS shall be provided in quantities as indicated on signal flows and/or rack elevations, and as described for components and equipment within this Section and associated Subsections.
2. A UPS connected to a Normal power load shall be provided with enough battery capacity to bridge short duration loss of power and brownout events. The intent is to protect and prolong the life of sensitive processor based equipment, reduce power cycle time upon restoration of Normal power, and/or allow the User time to safely shut down components.
3. A UPS connected to Emergency (NEC Article 700), Legally Required Standby (NEC Article 701), or Optional Standby (NEC Article 702) AC power circuits shall be provided with enough battery capacity to bridge the maximum operation load of the connected equipment during the time from loss of Normal power to load handover to the electrical standby power system (typically generator startup time).

C. PS/V: Vertical Power Strip, single 120V 20A circuit, NEMA 5-20P plug input, minimum fourteen NEMA 5-15R outlets, mount to rear of rack interior (furnish where provided electrical receptacle quantities do not meet system requirements):

1. APC AP7530 with 40170-6INCH L5-20P adaptor; or
2. Eaton EPBZ97; or
3. Middle Atlantic PD-2420SC-NS; or
4. Tripp Lite PDUV20 with included L5-20P adaptor; or
5. Approved equal.

D. PS/H: Horizontal Power Strip, single 120V 20A circuit, NEMA 5-20P plug input, minimum eight rear-facing NEMA 5-15R outlets, single rack space (furnish where provided electrical receptacle quantities do not meet system requirements):

1. APC AP9563; or
2. Eaton EPBZ85; or
3. Middle Atlantic PD-920R-NS; or
4. Tripp Lite PDU 1220; or
5. Approved equal.

E. PDU/V: Vertical Power Distribution Unit, capable of multiple circuits and outlets, configured for circuit quantity, voltage, and amperage provided to rack; mount to rear of rack interior (furnish in coordination with provided electrical power):

1. Juice Goose PD Series; or
2. Middle Atlantic MPR Series; or

3. Middle Atlantic PDW Series; or
4. Approved equal.

F. UPS:

1. 2RU: Uninterruptable Power Supply, two rack space chassis, line interactive, surge suppression, 120V 20A circuit, minimum 1950VA load, plug input, minimum eight rear-facing NEMA 5-15R outlets:
 - a. APC Smart-UPS SMT2200RMUS; or
 - b. Eaton 5P2200RT; or
 - c. Middle Atlantic UPS-2200R-8IP; or
 - d. Tripp Lite SmartPro SM2200RMXL2UP; or
 - e. Approved equal.

PART 3 - EXECUTION

3.1 INSTALLATION, GENERAL

- A. Install in accordance with manufacturer's instructions.

3.2 PREPARATION

- A. Coordinate locations and sizes of junction boxes, outlets, and conduit with the work of other trades. Field verify compliance with the construction documents.
- B. Carefully inspect areas where equipment will be installed. Notify the Architect of any conditions that would adversely affect the installation and subsequent operation of the system.
 1. Repeat inspection on a regular basis to ensure ongoing work by other trades does not pose a conflict to Contractor's pending work.

3.3 INSTALLATION

A. General

1. Contractor shall demonstrate a reasonable standard of care. Installation shall be rendered in a workmanlike manner observing direction set forth herein as well as industry standard best practices.
2. In addition to any spare cabling shown on drawings, utilize industry best practice to pull additional spare cabling in conduit where logical. Neatly bundle a usable length of cable at each end of each spare circuit. All spare circuits shall be labeled and noted on the field drawings for inclusion into the record drawings.
3. Install any floor-mounted receptacles so that release buttons (for both receptacles and cable

connectors) are easily accessible when cable connectors are installed.

4. Blank panels and/or vent panels shall be installed in unused rack spaces. Ensure that air flow within the rack is maintained (i.e. cool air can enter the rack and hot air can exit the rack).
5. Equipment racks and other exposed equipment shall be kept covered and protected from airborne contaminants. Clean all equipment racks and the interior rack floor, prior to system final acceptance activities.
6. For racks installed in credenzas, fasten carpet tiles or low friction sliders to the bottom of the rack to protect the finish of the furniture.
7. Where the design location requires products, materials, or equipment to be visible to the public, manufacturers logos shall be removed if possible. Unless otherwise directed, neatly remove or logos.
8. AC power switches located on the front panel of equipment mounted in racks shall be covered by a security cover or utilize front panel lockout features. Exclusions from this list are items requiring user interface such as tuners and wireless microphone receivers.
9. Furnish all equipment with factory finish where possible using the standard available factory color(s) as selected by the Architect. Notify the Architect regarding color options of relevant equipment prior to ordering equipment from each manufacturer.

B. Suspended Systems

1. General

- a. Contractor shall provide Suspension system, including connection to structure, for all suspended components including but not limited to: loudspeakers, video projectors, flat panel displays, televisions, projection screens, etc.
- b. Suspension system design shall be created by the Contractor and include fully dimensioned detail documentation stamped by a structural engineer licensed in the location of the project per submittal requirements in Part 1 of this document.
- c. Contractor shall include a safety cable or other backup support mechanism.
- d. Suspension systems and installation shall conform to industry best practice standards as set forth in:
 - 1) "Basic Principles for Suspending Loudspeaker Systems" (JBL Professional Technical Note Volume 1, Number 14)
- e. Coordinate with General Contractor any supplemental building structure necessary to facilitate the approved suspension design.
- f. Field verify conditions for compliance with the approved suspension plan prior to installation, placement of equipment orders, or material fabrication. Coordinate with other trades as necessary.

2. Loudspeakers

- a. Install loudspeakers so there are no obstructions to loudspeakers' coverage pattern.

- b. Loudspeakers shall be installed such that they do not produce or cause mechanical rattles in the surrounding structure. There shall be no audible vibration or noise caused by improper mechanical installation or defective components.
- c. Paint loudspeaker and/or grille assembly (at discretion of Architect or Design Consultant) color as selected by the Architect. Use primer per manufacturer's recommendations. Do not paint loudspeaker cones or high frequency diaphragms. Materials and labor provided by Contractor.
- d. Provide access to loudspeakers during installation, testing, and final acceptance activities to allow for modifications to location or installation. Access includes all necessary resources required to obtain direct physical contact to loudspeakers (front and rear), including: scaffolding, motorized lift, etc.
- e. Provide ability to reorient loudspeakers in all axes (yaw, pitch, and/or roll) if so requested by Design Consultant during system final acceptance activities.
 - 1) Do not perform final suspension connections prior to final acceptance by the Design Consultant including: permanent cable swage, elimination of wire rope service loop, etc.

C. Grounding

- 1. Comply with NEC and BICSI grounding requirements.
- 2. Each equipment rack within a row of racks and each row of racks within a room shall be electrically bonded to each other. Bonding shall be via copper ground bus. Any bolts shall fasten to unpainted sheet metal.

D. Equipment Power Control

- 1. Low-voltage "ON/OFF" control of system equipment shall be provided via the control system.
- 2. Operation of the following components is required, at a minimum:
 - a. Power amplifiers as indicated in Part 2 requirements
 - b. UPS connected devices where components do not require power under system shutdown
 - c. Components equipped with power state control
- 3. Make all low-voltage connections as required to provide a complete and working control system.
- 4. Refer to drawings for additional low-voltage sequencing system requirements.
- 5. Refer to electrical drawings for AC power information.
- 6. Coordinate with Electrical Contractor as necessary to verify proper circuit assignment and sequencing order.

3.4 CABLE MANAGEMENT AND TERMINATION

- A. Employ cable management and installation techniques to fulfill ANSI/AVIXA 10:2013, 9.4 (ANS2013-12-20) "Cable Management, Termination, and Labelling Reference Verification Items" as a minimum

standard with the additional requirements as described in this paragraph.

B. General

1. Do not violate the minimum cable bend radius as specified by the cable manufacturer.
2. Dress cables so terminations are free from stress due to gravity acting on the cabling. Use cable supports as required depending on the size and stiffness of the cable.
3. Terminate cables with sufficient service loop to allow at least one re-termination without having to open a cable bundle or pathway.
4. All circuits, including various audio signal levels, shall be separated according to function. Where audio and video circuits are installed in conduit or other raceway, separate conduits are required for the various circuit functions.
5. Where circuits are exposed in the equipment racks or large junction or pull boxes, circuits shall be bundled according to function. Refer to "Conduit/Circuit Group Divisions" and "Conduit Routing and Separation" schedules for additional information.
6. All solder connections shall be made with soldering iron and rosin core solder. All solder connections shall be checked for "cold" solder joints.
7. If equipment is removed or replaced for service, ensure the proper cable termination points are apparent when the equipment is re-installed.

C. Equipment Racks

1. Use Velcro tie wraps for dressing cables within the rack(s), hand tightened and spaced at various inconsistent distance intervals.
2. Do not use zip ties for UTP cables or any in-rack cables.
3. When dressing cables within the rack, do not tighten tie wraps so the cable is deformed.
4. Install rack-mounted equipment manufactured without IEC removable power cords so the power cords are dressed using removable fasteners such as Velcro and there are no obstructions to the item being pulled out from the front of the rack. Avoid coiled or bundled cable loops.
5. For rack-mounted equipment manufactured with IEC removable power cords, provide power cord assemblies of the minimum length needed to accomplish connection to the PDU. Avoid excess power cabling including coiled or bundled cable.
6. Factory terminated cable assemblies are only permitted for use within racks, between devices external to racks, as portable equipment, or for use in conduit as specifically noted as follows: Permitted for rack inter-connect when racks are in close proximity (same room) and may pass thru conduit if necessary in this situation. Cable assemblies shall be the minimum length needed to accomplish the connection.
7. Install rack equipment to enable repair or replacement without hindrance. If there are obstructions prohibiting the disconnection of terminations on the back side of the technical equipment, there must be sufficient cabling to permit the equipment to be pulled from the front allowing for easy disconnection and reconnection.

D. Paralleling and Extension Connections

1. Circuits shall not be joined by butt-splice, solder-splice, wire nut, or similar.
2. Circuits requiring parallel connection as indicated on signal flows shall be extended via approved termination in an appropriately sized junction box and shall conform to the following guidelines:
 - a. Approved connections include DIN mounted terminal blocks as specified in Part 2.
 - b. Field splicing techniques such as wire nuts, “twist and solder”, etc. are not allowed.
 - c. Any circuit requiring parallel connection shall be permanently labelled on every cable as defined herein.
 - d. Care must be taken to maintain appropriate protection and shielding of circuits in order to maintain a fully functional system.
3. Circuits requiring extension (non-data) due to field conditions such as excessive conduit bends, etc., shall be extended via approved termination in an appropriately sized junction box and shall conform to the following guidelines:
 - a. Extension of circuits is to be avoided if at all possible.
 - b. Contact the Design Consultant via documented project communication. Inform the Design Consultant of the circumstances regarding the desired extension. Contractor and Design Consultant will coordinate to determine the most appropriate course of action.
 - c. Approved connections include DIN mounted terminal blocks as specified in Part 2.
 - d. Any circuit requiring extension shall be permanently labelled on every cable as defined herein.
 - e. Care must be taken to maintain appropriate protection and shielding of circuits in order to maintain a fully functional system.
4. Document each parallel connection and extension on the field drawings and transfer same to the final record drawings.

E. Telecommunications Cabling

1. Refer to Division 27 Section “Telecommunications Requirements for Audio Video Systems” for all work associated with data-related cabling including Category and Fiber Optic cabling.
2. All data-related cabling entering a rack shall be terminated to a Data Patch Panel. Rack inter- and intra-connect cabling utilizing factory-terminated cable assemblies are not required to pass thru a Data Patch Panel.
3. All Fiber Optic cabling entering a rack shall be terminated to a Fiber Patch Panel. Rack inter- and intra-connect cabling utilizing factory-terminated cable assemblies are not required to pass thru a Fiber Patch Panel.

F. Microphone/Line Level Audio

1. Audio circuit termination shall observe the methods set forth in “Sound System Interconnection” RaneNote 110, © 2011 by Rane Corporation. This reference document may be obtained at: http://www.rane.com/pdf/ranenotes/Sound_System_Interconnection.pdf

2. Key methods include, but are not limited to the following:
 - a. All audio circuits shall be balanced two-wire circuits, with a separate grounding shield conductor, unless noted otherwise. All circuits shall have either the red or white wires as the "high" or "+" side of the line and connect to pin 2 of microphone-type XLR audio connectors and the tip of 3-conductor phone connectors. The black wire of the two-wire circuit shall be the "low" or "-" side of the line and connect to pin 3 of microphone connectors and the ring of 3-conductor phone connectors. The shield conductor shall connect to pin 1 of microphone connectors or to the sleeve of phone connectors.
 - b. Shield conductors shall be connected at each end of each wire to the pin 1 of each XLR, shield connection for each electronic device, etc. No shield wires shall be left unconnected except where noted on the drawings, nor shall any shield come in contact with conduit, pull boxes, or other building steel. Audio line-level circuit shield wires shall be grounded to rack sheet metal only via rack-mounted equipment. Shields shall be electrically isolated in multi-conductor cables. Shields for audio line-level circuits connected to audio transformers shall be connected to transformer electro-static shields and case ground.
 - c. In the case of an unbalanced source feeding into a balanced input and the cable run is short (i.e. less than fifteen feet), connect the signal connection of the unbalanced connector to the "high" side of the balanced input. Connect the "ground" connection of the unbalanced line to the "low" side of the balanced connector. Connect the cable shield to the shield connection of the balanced input but do not connect it to the unbalanced connector. If the cable run is longer than fifteen feet, balance the line at the unbalanced source using specified balancing devices.
 - d. In the case of a balanced source feeding into an unbalanced input and the cable run is short (i.e. less than fifteen feet), connect the "high" side of the balanced output to the signal input of the unbalanced connection. Connect the "shield" of the balanced connection to the "ground" of the unbalanced connection. Leave the "low" side of the balanced output floating.

G. Loudspeaker Level Audio

1. Loudspeakers in the same acoustic space shall all be wired to produce consistent polarity with a mono input signal. They shall also be polarized such that a positive acoustic pressure on a microphone results in a positive acoustic pressure at all loudspeakers.

3.5 LABELING

- A. Adhere to AVIXA F501.01:2015 "Cable Labeling for Audiovisual Systems" as a minimum standard with additional requirements as described in this paragraph.
- B. Refer to Division 27 Section "Telecommunications Requirements for Audio Video Systems" for all labeling requirements associated with data-related cabling including Category and Fiber Optic cabling.
- C. Develop and utilize a consistent numbering schema across the entire project. Utilize system names and building references where applicable, such as the rack number or rack room in a distributed system. All labels for input/output plates and control panels shall be consistent with the final room numbering for the facility.
- D. Adhere to the labeling standard across all platforms, including within the DSP programming.
- E. Refer to general notes, the signal flows, and panel and plate details for expected labeling scheme of

system equipment and components. Comply with any specific color coding as described.

- F. All equipment in equipment racks shall be labeled front and rear for ease of identification. Labels shall be of a contrasting color with that of equipment color to promote visibility.
- G. Install permanent labeling on the front of each equipment rack in a row of racks identifying the rack designation (number).
- H. Within each rack and at other remote locations for technical system equipment, label all associated AC power receptacles reflecting the appropriate circuit breaker. Ensure that the circuit breakers are labeled as to the rack or remote equipment location.
- I. Document the labeling standard for inclusion in the Operation and Maintenance Data.
- J. Document all labels for the Record Drawings.
- K. Pre-approved labelling systems include:
 - 1. Brother P-touch EDGE with HGeS2***PK labels; or
 - 2. Brady Equipment Identification Labels.

3.6 SYSTEM CONFIGURATION

- A. Coordination
 - 1. Coordinate and take responsibility for the approval of all system configuration components as described in this paragraph.
 - 2. Coordinate all aspects of the technical system network, including configuration and connection with to the Owner's LAN. Utilize Owner's designated configuration style, standards, and security requirements.
- B. Software
 - 1. Furnish, install, and configure the most recent approved, non-beta, software for each device or system.
 - 2. Provide software as identified in other areas of these specifications or on the drawings.
 - 3. Provide software not specifically identified but required to allow for system operation and/or to allow for more efficient system configuration, setup, and operation.
- C. Firmware
 - 1. Ensure the firmware for each device is the most recent manufacturer approved version and is installed and operational.
- D. Operating Systems
 - 1. Gain approval of the operating system version and type from the Owner's IT representative and associated equipment manufacturer(s).

2. Ensure the operating system for each device is the most recent, installed, and fully operational.
3. Ensure the latest security patches are installed.

E. Network Configuration

1. All technical system devices with an Ethernet port shall be connected to the associated network.
2. Secure the entire network, documenting all passwords. Comply with the Owner's IT representative's requirements with respect to password selection and network security implementation.

F. Network Documentation

1. Document the IP and MAC addresses of all IP capable equipment for inclusion with the Operation & Maintenance Manuals.

3.7 CONTRACTOR'S TESTING, ADJUSTMENT, AND SUBMITTAL REQUIREMENTS

A. At the completion of the installation, perform the following tests on the system to ensure proper installation and operation. The technical system shall be fully tested with all equipment on site, installed, connected, and fully operational.

B. The Contractor shall submit the results of all tests prior to on-site system review by the Design Consultant. Where available, provide documentation obtained directly from the test equipment. Other acceptable documentation includes screen captures, photos, and spreadsheets.

C. General

1. Utilize the technical support services offered by the manufacturers of the various technical system components to ensure optimum performance.
2. All test equipment used for these tests shall be on site during the system final acceptance activities should verification of submitted measurements be required.
3. Ensure that all equipment is on the job-site and fully operational. This includes portable (not installed) items and other loose equipment. Remove all devices from shipping or packaging containers, ready for use, and place in equipment storage cabinet.
4. The functional tests shall include operational tests of all program source equipment (record and playback), wireless microphone system, mixing console, system inputs and outputs, all patch panel receptacles, intercom system, video routing, video distribution, operational controls, AC power sequencing, operation of software, and all system electronics. Functional tests include examination for hum, buzz, hiss, ghosts, hum bars, oscillation, thumps, unintended reception of other signals such as AM or FM radio, TV, CB, ham radio, cell phones, or any other unwanted signals through the system.
5. Ensure all inputs and outputs are wired to the appropriate devices per construction documents.
6. Verify system startup and shutdown operates in the proper sequence.
 - a. System head end components shall be energized at the beginning of the startup sequence in an appropriate order to guarantee proper communication will associated devices.

- b. Loudspeaker power amplifiers shall be energized at the end of the sequence in order to eliminate unwanted transients being reproduced through system loudspeakers.
 - c. System shutdown sequence shall be in reverse order.
7. Where a system computer is furnished, load and configure all necessary control software. Examples include but are not limited to the following as applicable: wireless microphone management, amplification management, projector/display management, audio console configuration/control, DSP configuration/management, and active loudspeaker management.
 8. Where audio or video digital signal transport is required, ensure all network setup is complete including the installation and licensing of network management application software.

D. Required testing equipment

1. Certain systems/subsystems require testing and documentation via approved test equipment.
 - a. Systems requiring testing via approved devices will be identified below.
 - b. Required test devices will be listed in related sections.
 - c. Provide unified testing results of similar systems. Describe testing procedure including all test equipment used.
 - d. Provide original results from testing equipment (as applicable).
2. Failure to submit testing documentation conducted via approved devices will result in delayed final acceptance by the Design Consultant.
3. Contractors unable to provide required test equipment shall employ the services, at their own expense, of a certified subcontractor to assist in testing and documentation.

E. Audio System

1. Electronics
 - a. Test all system audio electronic components for uniform frequency response from input to power amplifier output:
 - 1) Supply pink noise to a single system input which engages most of the system electronics. For example, connect pink noise to a microphone receptacle on the stage for a Performing Arts facility.
 - 2) With all signal processing bypassed (equalization band pass filters, crossovers, dynamics, etc.), independently route the signal through audio console, DSP, and any other system processing components to an amplifier output.
 - 3) With speaker load disconnected, measure the signal response of the selected amplifier output (to obtain viable measurement results, ensure output level is set to match the ability of the measurement device to display accurate information. This can be accomplished via attenuation of signal or insertion of a speaker level to line level attenuator).
 - 4) Verify the measured response is uniform and matches the reference input signal within ± 1 dB from 30 Hz to 18 kHz.

- 5) Required test equipment - Signal Generation:
 - a) Terrasonde/Sencore Audio-Toolbox; or
 - b) Japan Audio Society CD-1 test compact disc
 - c) NTI Minirator MR-PRO
 - 6) Required test equipment – Measurement Device:
 - a) Rational Acoustics SMAART system v7 or later; or
 - b) NTI Audio XL2 Analyzer; or
 - c) Studio Six Digital Audio Tools RTA or FFT Module, with
 - i) Studio Six Digital iAudioInterface 2
 - b. Repeat measurement for each amplifier output channel.
2. Loudspeaker Impedance
- a. Measure and record the impedance of all loudspeaker circuits at the output of each amplifier. During this process, also check each loudspeaker circuit for shorts to ground.
 - b. Required test equipment:
 - a) Dayton Audio DATS; or
 - b) NTI Minirator MR-PRO; or
 - c) Sennheiser ZP-3; or
 - d) Terrasonde/Sencore Audio Toolbox
 - 2) Unacceptable measurement devices for loudspeaker impedance include the following:
 - a) Digital Multimeter (DMM); or
 - b) TOA ZM-104; or
 - c) TOA ZM-104A
3. Loudspeaker Band Pass/Amplifier Assignment Confirmation
- a. For full range loudspeakers, apply full spectrum pink noise at sufficient level in order to:
 - 1) Verify subjectively that each loudspeaker is emitting full spectrum signal (both woofer and tweeter/horn are operating)
 - 2) Confirm each loudspeaker is connected to the proper amplifier chassis and output channel.
 - 3) Verify proper phase of each loudspeaker.

- 4) Required test equipment
 - a) Galaxy Audio CPTS Cricket Polarity Tester; or
 - b) NTI Audio MR-PRO generator with XL2 Analyzer; or
 - c) Studio Six Digital Audio Tools Speaker Polarity Module; with
 - i) Studio Six Digital iAudioInterface 2 and Type 1 or 2 Test microphone; or
 - ii) Studio Six Digital iPrecisionMic; or
 - iii) Studio Six Digital iTestMic; or
 - d) Studio Six Digital Speaker Pop; with
 - i) Studio Six Digital iAudioInterface 2 and Type 1 or 2 Test microphone; or
 - ii) Studio Six Digital iPrecisionMic; or
 - iii) Studio Six Digital iTestMic

- b. For loudspeakers with multiple band pass sections (bi-amp, tri-amp, etc.), apply appropriately band-limited pink noise at sufficient level to each device or band pass (i.e. high frequency section, mid frequency section, low frequency section):
 - 1) Verify subjectively that each loudspeaker is emitting appropriately band-passed spectrum signal.
 - 2) Confirm each band pass is connected to the proper amplifier chassis and output channel.
 - 3) Verify phase of each band pass
 - 4) Required test equipment
 - a) Galaxy Audio CPTS Cricket Polarity Tester; or
 - b) NTI Audio MR-PRO generator with XL2 Analyzer; or
 - c) Studio Six Digital Audio Tools Speaker Polarity Module; with
 - i) Studio Six Digital iAudioInterface 2 and Type 1 or 2 Test microphone; or
 - ii) Studio Six Digital iPrecisionMic; or
 - iii) Studio Six Digital iTestMic; or
 - d) Studio Six Digital Speaker Pop; with
 - i) Studio Six Digital iAudioInterface 2 and Type 1 or 2 Test microphone; or
 - ii) Studio Six Digital iPrecisionMic; or
 - iii) Studio Six Digital iTestMic

4. Loudspeaker Rattle
 - a. Verify each loudspeaker is connected to the respective power amplifier and test each loudspeaker throughout its usable frequency range using 1/3-octave bands of pink noise to ensure loudspeaker and related building systems do not rattle.
 - b. Required 1/3-octave band pink noise sources and test equipment include:
 - 1) Terrasonde/Sencore Audio-Toolbox; or
 - 2) Japan Audio Society CD-1 test compact disc
 - 3) NTI Minirator MR-PRO
5. Loudspeakers Uniformity of Coverage
 - a. Perform audio system verification per ANSI/AVIXA 1M-2009 for all loudspeakers. Document per guidelines set forth in the standard.
6. Loudspeakers Equalization
 - a. Perform sound system equalization to optimize system performance for the intended uses.
 - b. Every loudspeaker shall be equalized.
 - c. Required test equipment:
 - 1) Calibrated Type 1 or Type 2 microphones shall be used
 - 2) Studio Six Digital Audio Tools for the classrooms, meeting rooms, conference rooms gymnasium, lobby; with
 - a) Studio Six Digital iPrecisionMic; or
 - b) Studio Six Digital iTestMic; or
 - 3) SmaartLive (most current non-beta version) with SmaartLive approved:
 - a) Appropriate laptop
 - b) Microphone interface
 - 4) EASRA (most current non-beta version) with EASRA approved:
 - a) Appropriate laptop
 - b) Microphone interface
7. Microphone/Line Level
 - a. Verify that all microphone and line level cabling and connectors are installed with Pins 1, 2, and 3 wired properly and there are no shorts to ground. Ensure proper polarity.
 - b. Verify that all microphone connectors, extension cables, and microphones are wired properly and in polarity.

c. Required test equipment:

- 1) Alphonon ACT-100 Remote Tester; or
- 2) NTI Minirator MR-PRO with Cable Test Adapter
- 3) A microphone is NOT an acceptable measurement device for cable tests.

8. Wireless Microphones

a. Setup and configure each wireless microphone system using the software provided by the manufacturer of the wireless microphone system. The following tasks are required:

- 1) Utilize wireless microphone management system if applicable, e.g., Shure Wireless Workbench, to perform an RF spectrum sweep.
- 2) Perform frequency coordination with Owner. Take into account existing wireless microphone system(s).
- 3) Calculate spare RF channels (based on 5% of the total wireless system channels).
- 4) Perform frequency assignment of all transmitters/receivers per the results of the frequency coordination and RF spectrum sweep.
- 5) Verify all receivers are set to maximum line level audio output.
- 6) Set all handheld wireless transmitter microphone sensitivity settings to allow high level voice output without AF over modulation. All transmitters should be set the same.
- 7) Set all body pack wireless transmitter microphone sensitivity settings to allow high level voice output without AF over modulation. All transmitters should be set the same.
- 8) Using subjective listening, adjust the body pack settings to match the audio level of the handheld transmitters.
- 9) Walk the entire performance coverage area using speech as the program material to verify signal performance. Utilize wireless microphone management system if applicable, e.g., Shure Wireless Workbench, to perform a QOS test.
- 10) Document wireless microphone frequency assignments including coordinated spare channels.

9. Production Intercom System

a. Verify that all intercom level cabling is installed with pins 1, 2, and 3 wired properly and there are no shorts to ground. Ensure intercom system power supply is disconnected for these tests.

b. Required test equipment:

- 1) Alphonon ACT-100 Remote Tester; or
- 2) NTI Minirator MR-PRO with Cable Test Adapter

10. Assistive Listening System

- a. Setup and configure the assistive listening system. Verify proper input signal level.
- b. Walk the entire coverage area using speech as the program material to verify signal performance.
- c. Set all receivers to match the selected transmit channel(s).

F. Control System

1. Verify performance of the Control System including the operation of all control features.

G. Adjustment

1. Repair or replace any defects or malfunctions found prior to the commencement of final acceptance activities by the Design Consultant.

H. Testing Documentation Submittal

1. Document the results of all tests and compile into a complete Testing Documentation submittal with the following items:
 - a. Results of the tests detailed herein; and
 - b. Documentation of changes to the systems as a result of any project Change Order, ASI, field directive, Owner Representative direction or the Testing and Adjustment process.
 - c. Digital photographs of primary systems, sub-systems and components; and
 - d. Written notice to the Design Consultant that the system(s) are ready for final acceptance.
2. Include the approved Testing Documentation package in the Operation and Maintenance Data package.
3. Modify the Record Drawings to include any changes as a result of the adjustment process.

I. Contact the Design Consultant should problems or concerns arise during the testing activities.

J. Transmit the Testing Documentation submittal to the Design Consultant in a timely fashion to allow the Consultant appropriate time for review and comment prior to final commissioning. Provide a minimum of five (5) business for review. The Consultant cannot schedule the commissioning site visit or begin the commissioning phase until the submittal has been approved.

K. Should the Design Consultant be required to invest time performing some or all of the tests, the Contractor will compensate the Design Consultant for all associated costs.

3.8 FINAL ACCEPTANCE

A. After completion of the system installation and after the preliminary tests and adjustments are complete, the contractor in conjunction with the Design Consultant shall perform on-site acceptance of the technical system. This process will include, but not be limited to the following, as applicable:

1. Random verification of contractor tests;

2. System check-out;
 3. Tailoring of the technical system's frequency response to the facility's acoustical environment (where required);
 4. Observation of video system to verify proper image display;
 5. Function and operability of the control system.
- B. Provide the services of the designated supervisor and any other technicians who are familiar with the system, for approximately two ten-hour days per school. Additional time may be required due to Alternates accepted by the Owner's Representative, or due to Addenda or Change Orders (if any) which modify the scope of work. The supervisor shall provide personal assistance during these activities. This time period does not include time for correcting wiring errors, equipment malfunctions, or problems related to the installation of the technical system. This work could occur at any time day, night, weekends, or holidays without additional claims for expense.
 - C. At the discretion of the Design Consultant, the Contractor shall participate in the control and adjustment of computer controlled systems including but not limited to the following systems: Main control (Crestron/AMX), DSP, wireless microphone, amplifier, active loudspeaker, etc.
 - D. At the completion of the final acceptance period, the Contractor shall compile all system configuration settings (files) with copies as required for inclusion in the O&M Manuals described later in these specifications.
 - E. In addition, provide the following: hand and power tools appropriate for the type of installation, ladders, lifts, and/or scaffolding as required to reach all high-mounted devices, spare wire and cable of the types used in the installation, selection of wiring fasteners used in the installation, complete set of the most recent reviewed shop drawings, complete set of all manufacturers' original installation/operation/maintenance manuals, and specific test equipment used during the preliminary testing activities.
 - F. After the technical system is operational, the Contractor shall provide verbal instruction to designated Owner's Representative as to proper methods of system operation. Video record the instruction class and provide the recording in a usable digital format to the Owner's Representative.
 - G. Provide operational assistance for the first major use of the completed system as directed by the Owner's Representative, including being present for: one prior rehearsal associated with the event (if applicable); a technical-check immediately prior to the event; and the event itself.

3.9 OPERATION AND MAINTENANCE DATA

- A. At the completion of the project, compile thorough copies of the Operation and Maintenance (O&M) Data per Division 27 Section "General Communications Requirements".
- B. O&M data shall be assembled according to rooms or areas as it relates to the project site. The intent is to allow the Owner's Representative to easily locate information relating to a specific system/room without having to spend an inordinate amount of time searching. Include complete information for each system/room – this may involve duplication of information.
- C. Include ANSI E1.47-2017 (Entertainment Technology – Recommended Guidelines for Entertainment Rigging System Inspections) within the O&M data.
- D. As applicable, save full digital version to the system computer.

END OF SECTION 274100

SECTION 274110 - TELECOMMUNICATIONS REQUIREMENTS FOR AUDIO VIDEO SYSTEMS

PART 1 - GENERAL

1.1 SUMMARY

- A. Provide a Telecommunications Structured Cabling System to support a complete and functioning Audio Video System. Elements of the work include, but are not limited to, materials, labor, supervision, supplies, tools, equipment, and transport to provide the following:

1. Shielded Category 6 Horizontal Cabling
2. Category 6 Faceplates & Shielded Connectors
3. Modular Category 6 Patch Panels
4. Shielded Category 6 Patch Cables
5. Category 6 Horizontal Cabling
6. Category 6 Faceplates & Connectors
7. Category 6 Patch Cables
8. Category 3 Horizontal Cabling
9. Category 3 Faceplates & Connectors

Category 3 Patch Cables

10. Optical Fiber Cabling
11. Optical Fiber Connectors, Adapters, & Rack-Mount Enclosures
12. Optical Fiber Patch Cables

- B. All Category 6 and fiber optic components provided under this section shall comply with Warranty requirements as defined within this section and shall be installed and tested by a certified contractor of the warranty provider. Refer to the Quality Assurance and Warranty paragraphs of this specification for more information on this requirement.

1.2 RELATED SECTIONS INCLUDE THE FOLLOWING

- A. Except as modified by governing codes and by the Contract Documents, comply with the applicable provisions, requirements, and recommendations in Division 27 Section "General Communications Requirements"
- B. Work under this section shall follow Division 27 Section "Common Work Results for Communications" for general pathway, firestopping, access panel, identification, and other requirements.
- C. Refer to Division 27 section <coordinate with Telecom designer> for approved Telecommunications System manufacturers.
- D. Refer to Division 27 "Audio Video Systems" and related sections and drawings for additional requirements and coordination items. Coordinate all work with Division 27 "Audio Video Systems" Contractor.

1.3 CODES, STANDARDS, AND GUIDELINES

- A. In addition to all applicable codes, standards, and guidelines listed in Division 27 Sections "General

Communications Requirements” and “Audio Video Systems”, follow the most recent editions of the following:

1. NFPA 70 – National Electrical Code (NEC)
2. IEEE National Electrical Safety Code (NESC)
3. ANSI/EIA/TIA 455 50B, Light Launch Conditions For Long-Length Graded-Index Optical Fiber Spectral Attenuation Measurements
4. ANSI/TIA/EIA-455-59A, Measurement of Fiber Point Discontinuities Using an OTDR.
5. ANSI/TIA/EIA 455 60A, Measurement of Fiber or Cable Length Using an OTDR.
6. ANSI/TIA/EIA 455 61A, Measurement of Fiber or Cable Attenuation Using an OTDR.
7. ANSI/TIA/EIA 526 7, Optical Power Loss Measurements of Installed Singlemode Fiber Cable Plant.
8. ANSI/TIA 526 14 B, Optical Power Loss Measurements of Installed Multimode Fiber Cable Plant; IEC 61280-4-1 edition 2, Fiber-Optic Communications Subsystem Test Procedure- Part 4-1: Installed cable plant- Multimode attenuation measurement.
9. TIA-TSB-140 – Additional Guidelines for Field-Testing Length, Loss and Polarity of Optical Fiber Cabling Systems
10. ANSI/TIA-568-C.O - Generic Telecommunications Cabling for Customer Premises
11. ANSI/TIA-568-C.1 - Commercial Building Telecommunications Cabling Standard Part 1: General Requirements
12. ANSI/TIA-568-C.2 - Balanced Twisted-Pair Telecommunications Cabling and Components Standards
13. ANSI/TIA-568-C.3 - Optical Fiber Cabling Components Standards
14. ANSI TIA-569-C – Commercial Building Standard for Telecommunications Pathways and Spaces
15. ANSI TIA-606-B – Administration Standard for Commercial Telecommunications Infrastructure
16. ANSI Z136.2, ANS For Safe Use Of Optical Fiber Communication Systems Utilizing Laser Diode And LED Sources
17. BICSI - Telecommunications Distribution Methods Manual
18. BICSI – Information Technology Systems Installation Methods Manual

1.4 DEFINITIONS

- A. Contractor – in regards to this section only, the contractor responsible for providing a complete Telecommunications Structured Cabling System for Audio Video Systems.
- B. Direct Attach Method – as defined in ANSI/BICSI 005-2013, the horizontal cabling on the remote device end directly attaching (or connecting) to the device through a connectorized cable or hard-wired termination, eliminating the workstation outlet, jack and equipment cord.
- C. Horizontal Cabling
 1. Horizontal cable and its connecting hardware provide the means of transporting signals between the telecommunications outlet/connector and the horizontal cross-connect located at the equipment rack. This cabling and its connecting hardware are called "permanent link," a term that is used in the testing protocols.
 - a. Horizontal cabling shall contain no more than one transition point or consolidation point between the horizontal cross-connect and the telecommunications outlet/connector
 - b. Bridged taps and splices shall not be installed in the horizontal cabling
 - c. Splitters shall not be installed as part of the optical fiber cabling
 2. The maximum allowable horizontal cable length for Category copper cable is 295 feet (90 meters), which includes total cable length (including vertical routing and slack). Horizontal cables longer

TELECOMMUNICATIONS REQUIREMENTS

than 295 feet shall be optical fiber.

- D. Structured Cabling / Telecommunications System – a fully-functional passive telecommunications system (infrastructure), that includes permanently installed category copper and fiber optic cable terminated onto a patch panel or outlet.
- E. Technical System Ground – the isolated ground system provided specifically for the Technical (AV) System, as specified in Division 27 section “Audio Video Systems”.
- F. Wet Location - as defined in the NEC, installations underground or in concrete slabs or masonry in direct contact with the earth; in locations subject to saturation with water or other liquids, such as vehicle washing areas; and in unprotected locations exposed to weather.

1.5 QUALITY ASSURANCE

A. Personnel Qualifications

- 1. The person(s) conducting the testing for all Telecommunications cabling shall be a current BICSI Certified Level II Commercial Installer or higher.
 - a. Additionally, persons conducting the testing for all fiber optic cabling shall have successfully attended an appropriate training program which includes testing with an OLTS and OTDR and have obtained a certificate as proof thereof. The certified training program shall be:
 - 1) BICSI ITS Installer 2 Optical Fiber
 - 2) Or approved equal
 - b. Submit certificates with pre-construction submittals.
- 2. Any additional personnel that will be physically installing any part of the Telecommunications Infrastructure covered by this Section shall, at a minimum, be a BICSI Certified Level 1 Commercial Installer in good standing or have equivalent manufacturer training.
- 3. These requirements are provided as a minimum level of qualification. Any additional or more stringent requirements by the specific manufacturer chosen to provide the proper level or term of warranty as specified in this division shall be met.
- 4. Alternate qualifications may be considered if requested alternates are provided in accordance with the Substitution instructions in Division 27 Section “General Communications Requirements”.

1.6 SUBMITTALS

- A. Follow the requirements for submittals in Division 27 Sections “General Communications Requirements” and “Audio Video Systems”.
- B. Pre-construction - Follow exact Division 27 Section “Audio Video System” submittal requirements, with additional requirements as noted:
 - 1. Manufacturers’ Cut-sheets – Additional requirements as follows:
 - a. Product data on cabling shall contain the following:
 - 1) Manufacturers name and logo
 - 2) Cable outside diameter
 - 3) Number of conductors/strands in each cable
 - 4) Gauge or strand thickness

TELECOMMUNICATIONS REQUIREMENTS

- 5) Minimum transmission performance rating
- 6) Cable jacket material and rating
- 7) Maximum pulling tension
- 8) Jacket/Sheath color
- 9) Minimum bend radius

a) During installation and post installation, if different

- b. Product data on faceplates, modules, connectors, patch panels, and enclosures shall contain the following:
 - 1) Manufacturers name and logo
 - 2) Material type
 - 3) Performance rating
 - 4) Physical Dimensions
 - 5) Color

2. Shop Drawings

- a. Scaled layout drawings showing the routing (and support method) of all cabling, and the locations where patch panels, Telecommunications outlets, cable types, cable jacket listing information, firestop locations (with quantity and NRTL system number identified), and fiber optic termination panels are to be installed.
 - 1) Each individual outlet on the drawings shall have proposed outlet identification indicated.
- b. Scaled enlarged plan and rack elevation drawings showing the locations of patch panels and Rack-Mount Enclosures.
- c. Unless otherwise required by these specifications, it is permissible to show Work in this section on Division 27 “Audio Video Systems” shop drawings.

3. Warranty Information

- a. Subject to Warranty paragraph, provide sample warranty certificate for the Warranty, indicating manufacturer and their terms/conditions
- b. Proof that Contractor is certified with the manufacturer

C. Project Completion - Follow exact Division 27 Section “Audio Video Systems” submittal requirements, with additional requirements as noted:

- 1. As part of Division 27 Audio Video Systems – Operation & Maintenance Data submittal, also include the following documentation:
 - a. Warranty Certificates (if applicable)
 - b. Cable routing and Outlet locations identified on Audio Video Systems Final Record Drawings, in searchable Acrobat PDF format (so that Work Area Outlet identifiers can be searched for)
 - c. Test Results, in PDF, spreadsheet and original test equipment format
 - d. Delivery confirmation of spare Patch Cables delivered to Owner
 - 1) Refer to Division 27 “Audio Video Systems” and herein for quantities

1.7 COORDINATION

- A. Review pathways and other Work, as installed per Division 27 section “Common Work Results for Communications”, prior to performing any Work under this section for conformance to all referenced

codes, standards, and guidelines.

1. While Division 27 section “Common Work Results for Communications” is being installed, the Project Manager of this section and the Project Manager of Division 27 “Audio Video Systems” contractor shall make weekly inspections and report any issues to the Prime Contractor for correction prior to installation of any cabling.
 - a. Example – Conduit for Category 6 data outlets shall not contain more than two 90 degree bends between pull points.
- B. For projects with other Division 27 telecommunications work, coordinate with Division 27 Telecommunications Contractor(s) prior to bid – similar products shall be by the same manufacturer.
 1. This includes:
 - a. Horizontal and backbone cabling
 - b. Copper connectivity
 - c. Fiber connectivity
- C. Coordinate with Division 27 “Audio Video Systems” contractor for all Work in AV equipment racks.

1.8 WARRANTY

- A. Utilize either sub-paragraph A or B. If A is removed, remove references to Advanced System Warranty throughout document. In that case, leave B to serve as reference for Part 2 products.
 1. Warranty shall be guaranteed by a single reputable manufacturer such as:
 - a. Belden
 - b. Hubbell
 - c. Leviton
 - d. Mohawk Cabling
 - e. Ortronics
 - f. Panduit
 - g. Superior Essex
 - h. Systemax
 - i. Or Approved Substitution (submitted and accepted in the “pre-bid” phase)
 2. This warranty shall extend to Category Neutrik connectors specified in Division 27 “Audio Video Systems”. Coordinate with proposed manufacturer of Advanced System Warranty prior to bid to ensure they will extend coverage to this product for this project.
 - a. Include letter in Pre-Construction Product Submittals from manufacturer certifying this requirement will be met.
 3. Where warranty is by connectivity manufacturer, all connectivity shall be by said manufacturer and cabling manufacturer shall be compatible for use with the selected connectivity.
 4. Where another Division 27 specifies a similar warranty and manufacturer for a telecommunications structured cabling system, provide products and a warranty from the same manufacturer.
 5. Perform the remedial work promptly, upon written notice from the Owner.
 6. At the time of Substantial Completion, deliver to the Owner all warranties, in writing and properly executed, including term limits for warranties extending beyond the one year period, each

TELECOMMUNICATIONS REQUIREMENTS

warranty instrument being addressed to the Owner and stating the commencement date and term.

- B. The Telecommunications Structured Cabling System (as specified in this Section) requires a standard one-year Warranty.

PART 2 - PRODUCTS AND MATERIALS

2.1 GENERAL REQUIREMENTS

- A. All cabling shall be from a single manufacturer.
- B. All connectivity shall be from a single manufacturer.
 - 1. Exception: Certain broadcast and faceplate connections/components as specified.

2.2 SHIELDED CATEGORY 6 HORIZONTAL CABLING

- A. All products in this category shall be from a single reputable manufacturer and comply with Coordination and Warranty requirements per Part 1 of this Section unless otherwise noted.
- B. Horizontal cables for dry environments
 - 1. Requirements
 - a. Minimum performance specifications: Cable shall meet requirements for Category 6 of TIA-568-C.
 - b. Aluminum Foil Tape Shield (F/UTP)
 - c. Four pairs of 23 AWG copper conductors with drain wire
 - d. Cable jacket color(s) shall be
 - 1) Purple
 - e. Cable jacket marking: Shall be legible and shall contain the following information:
 - 1) Manufacturer's name
 - 2) Copper Conductor Gauge
 - 3) Pair Count
 - 4) UL and CSA listing
 - 5) Manufacturer's trade mark
 - 6) Category rating
 - 7) Sequential distance markings, in one foot increments
 - f. Individually insulated conductors under a common sheath
 - g. Where all cables are to be installed in conduit from outlet box to AV Equipment Rack, cable shall be riser (CMR or MPR) rated. Where any portion of any cable is routed in an air plenum space, cable shall be plenum (CMP) rated.
 - 2. Manufacturer shall be:
 - a. From the following list, subject to Coordination and Warranty requirements:
 - 1) Superior Essex CAT 6+ ScTP
 - 2) Belden DataTwist 2400
 - 3) Berk-Tek LANMARK-6 FTP
 - 4) Hitachi Shielded Category 6 Cable
 - 5) Hubbell Speedchannel FTP Cable, Category 6
 - 6) Mohawk Category 6 F/UTP

TELECOMMUNICATIONS REQUIREMENTS

7) Panduit TX6000 Shielded Copper Cable

C. Horizontal cables for wet environments in ducts/conduits

1. Requirements

- a. To be used for pathways in or below slab-on-grade, or where any part of pathway is external to the building or in a Wet or Damp Location (as defined by the NEC).
 - 1) Pathway shall enter the building (where it stubs up out of the slab) in the AV Equipment Room, or within 50' of AV Equipment Room. Coordinate this requirement with Division 27 section "Common Work Results for Communications".
 - b. Suitable to be in contact with standing water.
 - c. Cable construction shall be consistent with manufacturer's specifications to comply with Warranty requirements.
 - d. Minimum performance specifications: Cable shall meet requirements for Category 6 of TIA-568-C.
 - e. Four pairs of 23 AWG solid copper conductors
 - f. Aluminum Tape Shield (F/UTP)
 - g. Cable shall be wet-rated / OSP-rated.
 - 1) And shall transition to a listed cable (plenum or riser rated as appropriate) where it enters the building.
 - 2) This transition is not needed if the conduit stubs up directly into the Communications Room.
 - h. Cable jacket marking: Shall be legible and shall contain the following information:
 - 1) Manufacturer's name
 - 2) Copper Conductor Gauge
 - 3) Pair Count
 - 4) UL and CSA listing
 - 5) Manufacturer's trade mark
 - 6) Category rating
 - 7) Sequential distance markings, in one-foot increments
2. Manufacturer shall be:
- a. From the following list, subject to Coordination and Warranty requirements:
 - 1) Superior Essex OSP Broadband Category 6
 - b. Or Approved Equivalent

2.3 CATEGORY 6 HORIZONTAL CABLING

A. All products in this category shall be from a single reputable manufacturer and comply with Coordination and Warranty requirements per Part 1 of this Section unless otherwise noted.

B. Horizontal cables for dry environments

1. Requirements

- a. Minimum performance specifications: Cable shall meet requirements for Category 6 of TIA-568-C.
- b. Four pairs of 23 AWG copper conductors
- c. Cable jacket color(s) shall be
 - 1) Purple
- d. Cable jacket marking: Shall be legible and shall contain the following information:
 - 1) Manufacturer's name

TELECOMMUNICATIONS REQUIREMENTS

- 2) Copper Conductor Gauge
- 3) Pair Count
- 4) UL and CSA listing
- 5) Manufacturer's trade mark
- 6) Category rating
- 7) Sequential distance markings, in one foot increments
- e. Individually insulated conductors under a common sheath
- f. Where all cables are to be installed in conduit from outlet box to AV Equipment Rack, cable shall be riser (CMR or MPR) rated. Where any portion of any cable is routed in an air plenum space, cable shall be plenum (CMP) rated.

2. Manufacturer shall be:

- a. From the following list, subject to Coordination and Warranty requirements:
 - 1) Superior Essex CAT 6+
 - 2) Belden DataTwist 2400
 - 3) Berk-Tek LANMARK-6
 - 4) Hitachi Category 6 Cable
 - 5) Hubbell Speedchannel Cable, Category 6
 - 6) Mohawk Category 6
 - 7) Panduit TX6000 Copper Cable

C. Horizontal cables for wet environments in ducts/conduits

1. Requirements

- a. To be used for pathways in or below slab-on-grade, or where any part of pathway is external to the building or in a Wet or Damp Location (as defined by the NEC).
 - 1) Pathway shall enter the building (where it stubs up out of the slab) in the AV Equipment Room, or within 50' of AV Equipment Room. Coordinate this requirement with Division 27 section "Common Work Results for Communications".
- b. Suitable to be in contact with standing water.
- c. Cable construction shall be consistent with manufacturer's specifications to comply with Warranty requirements.
- d. Minimum performance specifications: Cable shall meet requirements for Category 6 of TIA-568-C.
- e. Four pairs of 23 AWG solid copper conductors
- f. Cable shall be wet-rated / OSP-rated.
 - 1) And shall transition to a listed cable (plenum or riser rated as appropriate) where it enters the building.
 - 2) This transition is not needed if the conduit stubs up directly into the Communications Room.
- g. Cable jacket marking: Shall be legible and shall contain the following information:
 - 1) Manufacturer's name
 - 2) Copper Conductor Gauge
 - 3) Pair Count
 - 4) UL and CSA listing
 - 5) Manufacturer's trade mark
 - 6) Category rating
 - 7) Sequential distance markings, in one foot increments

2. Manufacturer shall be:

- a. From the following list, subject to Coordination and Warranty requirements:

TELECOMMUNICATIONS REQUIREMENTS

- 1) Superior Essex OSP Broadband Category 6
- 2) Or Approved Equivalent

2.4 CATEGORY 3 HORIZONTAL CABLING

A. All products in this category shall be from a single reputable manufacturer and comply with Coordination and Warranty requirements per Part 1 of this Section unless otherwise noted.

B. Horizontal cables for dry environments

1. Requirements

- a. Minimum performance specifications: Cable shall meet requirements for Category 3 of TIA-568-C.
- b. Two pairs of 24 AWG copper conductors
- c. Cable jacket color(s) shall be
 - 1) Purple
- d. Cable jacket marking: Shall be legible and shall contain the following information:
 - 1) Manufacturer's name
 - 2) Copper Conductor Gauge
 - 3) Pair Count
 - 4) UL and CSA listing
 - 5) Manufacturer's trade mark
 - 6) Category rating
 - 7) Sequential distance markings, in one foot increments
- e. Individually insulated conductors under a common sheath
- f. Where all cables are to be installed in conduit from outlet box to AV Equipment Rack, cable shall be riser (CMR or MPR) rated. Where any portion of any cable is routed in an air plenum space, cable shall be plenum (CMP) rated.

2. Manufacturer shall be:

- a. From the following list, subject to Coordination and Warranty requirements:
 - 1) Belden
 - 2) Hubbell
 - 3) Leviton
 - 4) Ortronics
 - 5) Panduit

C. Horizontal cables for wet environments in ducts/conduits

1. Requirements

- a. To be used for pathways in or below slab-on-grade, or where any part of pathway is external to the building or in a Wet or Damp Location (as defined by the NEC).
 - 1) Pathway shall enter the building (where it stubs up out of the slab) in the AV Equipment Room, or within 50' of AV Equipment Room. Coordinate this requirement with Division 27 section "Common Work Results for Communications".
- b. Suitable to be in contact with standing water.
- c. Cable construction shall be consistent with manufacturer's specifications to comply with Warranty requirements.
- d. Minimum performance specifications: Cable shall meet requirements for Category 3 of TIA-568-C.

TELECOMMUNICATIONS REQUIREMENTS

- e. Two pairs of 24 AWG solid copper conductors
 - f. Cable shall be wet-rated / OSP-rated.
 - 1) And shall transition to a listed cable (plenum or riser rated as appropriate) where it enters the building.
 - 2) This transition is not needed if the conduit stubs up directly into the Communications Room.
 - g. Cable jacket marking: Shall be legible and shall contain the following information:
 - 1) Manufacturer's name
 - 2) Copper Conductor Gauge
 - 3) Pair Count
 - 4) UL and CSA listing
 - 5) Manufacturer's trade mark
 - 6) Category rating
 - 7) Sequential distance markings, in one foot increments
2. Manufacturer shall be:
- a. From the following list, subject to Coordination and Warranty requirements:
 - 1) Superior Essex
 - 2) Or Approved Equivalent

2.5 SHIELDED CATEGORY 6 CONNECTIVITY

- A. All products in this category shall be from a single reputable manufacturer and comply with Coordination and Warranty requirements per Part 1 of this Section unless otherwise noted.
- B. Connectors / Jacks
 - 1. General Requirements
 - a. Outlets shall meet requirements for Category 6 of TIA-568-C.
 - b. All 8-position modular jacks are to be wired according to the TIA T568B pin/pair assignments.
 - c. Outlet hardware shall be UL listed.
 - 2. Female RJ-45 Shielded Category 6 Jack
 - a. For installation with shielded Category 6 cable into:
 - 1) Dedicated AV LAN faceplates (where no other type of AV connectors are needed)
 - 2) Rack-mounted Patch Panels
 - b. Manufacturer shall be from the following list, subject to Coordination and Warranty requirements:
 - 1) Ortronics TracJack
 - 2) Belden Key Connect
 - 3) Hubbell UDX
 - 4) Leviton QuickPort
 - 5) Panduit Mini-Com
 - 3. Male RJ-45 Shielded Category 6 connector
 - a. For installation onto far end of shielded Category 6 cable at the following locations only:
 - 1) In-wall Touch Panels
 - 2) Crestron DM Transmitters & Receivers

TELECOMMUNICATIONS REQUIREMENTS

- 3) Other locations where it is not practical to terminate cabling onto a faceplate or into a small Surface Mount (Biscuit) Box.
 - b. Manufacturer shall be from the following list, subject to Coordination and Warranty requirements:
 - 1) Ortronics TracJack
 - 2) Belden Key Connect
 - 3) Hubbell UDX
 - 4) Leviton QuickPort
 - 5) Panduit Mini-Com
 - 4. EtherCON Female RJ-45 Shielded Category 6 connector
 - a. For installation in custom AV faceplates where other types of AV connectors are needed
 - b. Manufacturer shall be:
 - 1) Refer to Division 27 Section "Audio Video Systems"
- C. Faceplates – where only AV LAN connectors are needed, such as behind a TV
- 1. Requirements
 - a. Stainless Steel with number of ports to allow all modular jacks to be installed as required, and as indicated on the drawings.
 - b. Color shall be stainless steel.
 - c. Single gang or double gang, as noted on the drawings or required to provide a complete and functioning system
 - 2. Product shall be as follows, subject to Coordination and Warranty requirements:
 - a. From the following list:
 - 1) Belden Key Connect
 - 2) Hubbell UDX
 - 3) Leviton QuickPort
 - 4) Ortronics TracJack
 - 5) Panduit Mini-Com
 - 6) Or Approved Equivalent
 - b. Decora-style inserts
 - 1) Provide as necessary per drawings/details
 - 2) Color shall match faceplate or electrical, or as directed by the architect
 - c. Blank inserts
 - 1) Provide blank modules to fill any unused openings in faceplates
 - 2) Color shall match other jack colors
- D. Surface mount ("Biscuit") box – for installation as needed in junction/back box, projector lift, etc. where installation of a faceplate is not practical.
- 1. Requirements
 - a. Thermoplastic surface-mount style box with number of ports to allow all jacks to be installed as required, and as indicated on the drawings.
 - 2. Product shall be as follows, subject to Coordination and Warranty requirements:
 - a. From the following list:
 - 1) Belden KeyConnect Side-Entry Box

TELECOMMUNICATIONS REQUIREMENTS

- 2) Hubbell iStation Surface Mount Box
- 3) Leviton QuickPort Surface-Mount Box
- 4) Ortronics TracJack Surface Mount Box
- 5) Panduit Mini-Com Surface Mount Box

E. Modular Category 6 Patch Panels

1. Requirements

- a. Be of a modular metal design with snap in frames for individual jacks/connectors.
- b. Ports and panels shall be easy to identify with label holders for machine-printed and color-coded labels. Rack mountable patch panels shall mount to standard 19" wide racks.
- c. Comply with referenced standards. Cables shall be terminated with connecting hardware of same category or higher.
- d. Patch panels shall be provided complete with all mounting hardware, modular jacks, retainers, wire guides, designation strips, etc.
- e. Provide enough patch panels for the number of cables terminated on the patch panel, plus 10 percent spare. Provide modular jacks to fill each panel completely. Do not leave any blank openings.

2. Product shall be as follows, subject to Coordination and Warranty requirements:

- a. From the following list:
 - 1) Belden KeyConnect Modular Patch Panels
 - 2) Hubbell UDX Panels
 - 3) Leviton QuickPort Patch Panels
 - 4) Ortronics OR-PHDPJU24
 - 5) Panduit Mini-Com Modular Patch Panels

2.6 CATEGORY 6 CONNECTIVITY

A. All products in this category shall be from a single reputable manufacturer and comply with Coordination and Warranty requirements per Part 1 of this Section unless otherwise noted.

B. Connectors / Jacks

1. General Requirements

- a. Outlets shall meet requirements for Category 6 of TIA-568-C.
- b. All 8-position modular jacks are to be wired according to the TIA T568B pin/pair assignments.
- c. Outlet hardware shall be UL listed.

2. Female RJ-45 Category 6 Jack

- a. For installation with Category 6 cable into:
 - 1) Dedicated AV LAN faceplates (where no other type of AV connectors are needed)
 - 2) Rack-mounted Patch Panels
- b. Manufacturer shall be from the following list, subject to Coordination and Warranty requirements:
 - 1) Ortronics TracJack
 - 2) Belden Key Connect

TELECOMMUNICATIONS REQUIREMENTS

- 3) Hubbell UDX
- 4) Leviton QuickPort
- 5) Panduit Mini-Com

3. Male RJ-45 Category 6 connector

- a. For installation onto far end of Category 6 cable at the following locations only:
 - 1) In-wall Touch Panels
 - 2) Crestron DM Transmitters & Receivers
 - 3) Other locations where it is not practical to terminate cabling onto a faceplate or into a small Surface Mount (Biscuit) Box.
- b. Manufacturer shall be from the following list, subject to Coordination and Warranty requirements:
 - 1) Ortronics TracJack
 - 2) Belden Key Connect
 - 3) Hubbell UDX
 - 4) Leviton QuickPort
 - 5) Panduit Mini-Com

4. EtherCON Female RJ-45 Category 6 connector

- a. For installation in custom AV faceplates where other types of AV connectors are needed
- b. Manufacturer shall be:
 - 1) Refer to Division 27 Section “Audio Video Systems”

C. Faceplates – where only AV LAN connectors are needed, such as behind a TV

1. Requirements

- a. Stainless Steel with number of ports to allow all modular jacks to be installed as required, and as indicated on the drawings.
- b. Color shall be stainless steel.
- c. Single gang or double gang, as noted on the drawings or required to provide a complete and functioning system

2. Product shall be as follows, subject to Coordination and Warranty requirements:

- a. From the following list:
 - 1) Belden Key Connect
 - 2) Hubbell UDX
 - 3) Leviton QuickPort
 - 4) Ortronics TracJack
 - 5) Panduit Mini-Com
 - 6) Or Approved Equivalent
- b. Decora-style inserts
 - 1) Provide as necessary per drawings/details
 - 2) Color shall match faceplate or electrical, or as directed by the architect
- c. Blank inserts
 - 1) Provide blank modules to fill any unused openings in faceplates
 - 2) Color shall match other jack colors

D. Surface mount (“Biscuit”) box – for installation as needed in junction/back box, projector lift, etc. where installation of a faceplate is not practical.

TELECOMMUNICATIONS REQUIREMENTS

1. Requirements
 - a. Thermoplastic surface-mount style box with number of ports to allow all jacks to be installed as required, and as indicated on the drawings.
2. Product shall be as follows, subject to Coordination and Warranty requirements:
 - a. From the following list:
 - 1) Belden KeyConnect Side-Entry Box
 - 2) Hubbell iStation Surface Mount Box
 - 3) Leviton QuickPort Surface-Mount Box
 - 4) Ortronics TracJack Surface Mount Box
 - 5) Panduit Mini-Com Surface Mount Box

E. Modular Category 6 Patch Panels

1. Requirements
 - a. Be of a modular metal design with snap in frames for individual jacks/connectors.
 - b. Ports and panels shall be easy to identify with label holders for machine-printed and color-coded labels. Rack mountable patch panels shall mount to standard 19" wide racks.
 - c. Comply with referenced standards. Cables shall be terminated with connecting hardware of same category or higher.
 - d. Patch panels shall be provided complete with all mounting hardware, modular jacks, retainers, wire guides, designation strips, etc.
 - e. Provide enough patch panels for the number of cables terminated on the patch panel, plus 10 percent spare. Provide modular jacks to fill each panel completely. Do not leave any blank openings.
2. Product shall be as follows, subject to Coordination and Warranty requirements:
 - a. From the following list:
 - 1) Belden KeyConnect Modular Patch Panels
 - 2) Hubbell UDX Panels
 - 3) Leviton QuickPort Patch Panels
 - 4) Ortronics OR-PHDPJU24
 - 5) Panduit Mini-Com Modular Patch Panels

2.7 CATEGORY 3 CONNECTIVITY

- A. All products in this category shall be from a single reputable manufacturer and comply with Coordination and Warranty requirements per Part 1 of this Section unless otherwise noted.
- B. Connectors / Jacks
 1. General Requirements
 - a. Outlets shall meet requirements for Category 3 of TIA-568-C.
 - b. Outlet hardware shall be UL listed.
 2. Female Category 3 Jack

TELECOMMUNICATIONS REQUIREMENTS

- a. For installation with Category 3 cable into:
 - 1) Dedicated AV LAN faceplates (where no other type of AV connectors are needed)
 - 2) Rack-mounted Patch Panels
 - b. Manufacturer shall be from the following list, subject to Coordination and Warranty requirements:
 - 1) Ortronics TracJack
 - 2) Belden Key Connect
 - 3) Hubbell UDX
 - 4) Leviton QuickPort
 - 5) Panduit Mini-Com
3. Male Category 3 connector
- a. For installation onto far end of Category 3 cable at the following locations only:
 - 1) Locations where it is not practical to terminate cabling onto a faceplate or into a small Surface Mount (Biscuit) Box.
 - b. Manufacturer shall be from the following list, subject to Coordination and Warranty requirements:
 - 1) Ortronics TracJack
 - 2) Belden Key Connect
 - 3) Hubbell UDX
 - 4) Leviton QuickPort
 - 5) Panduit Mini-Com
- C. Faceplates – where only AV LAN connectors are needed, such as behind a TV
- 1. Requirements
 - a. Stainless Steel with number of ports to allow all modular jacks to be installed as required, and as indicated on the drawings.
 - b. Color shall be stainless steel.
 - c. Single gang or double gang, as noted on the drawings or required to provide a complete and functioning system
 - 2. Product shall be as follows, subject to Coordination and Warranty requirements:
 - a. From the following list:
 - 1) Belden Key Connect
 - 2) Hubbell UDX
 - 3) Leviton QuickPort
 - 4) Ortronics TracJack
 - 5) Panduit Mini-Com
 - 6) Or Approved Equivalent
 - b. Decora-style inserts
 - 1) Provide as necessary per drawings/details
 - 2) Color shall match faceplate or electrical, or as directed by the architect
 - c. Blank inserts
 - 1) Provide blank modules to fill any unused openings in faceplates
 - 2) Color shall match other jack colors
- D. Surface mount (“Biscuit”) box – for installation as needed in junction/back box, projector lift, etc. where installation of a faceplate is not practical.

TELECOMMUNICATIONS REQUIREMENTS

1. Requirements
 - a. Thermoplastic surface-mount style box with number of ports to allow all jacks to be installed as required, and as indicated on the drawings.
2. Product shall be as follows, subject to Coordination and Warranty requirements:
 - a. From the following list:
 - 1) Belden KeyConnect Side-Entry Box
 - 2) Hubbell iStation Surface Mount Box
 - 3) Leviton QuickPort Surface-Mount Box
 - 4) Ortronics TracJack Surface Mount Box
 - 5) Panduit Mini-Com Surface Mount Box

2.8 SHIELDED CATEGORY 6 PATCH CABLES/CORDS

- A. All products in this category shall be from a single reputable manufacturer and comply with Coordination and Warranty requirements per Part 1 of this Section unless otherwise noted.
- B. Requirements
 1. Factory-terminated and tested
 2. Shall meet requirements for Category 6 of TIA-568-C
 3. Shielded
 4. Provide quantities and lengths as necessary for a complete Audio Video System; coordinate requirements with Division 27 "Audio Video Systems" contractor.
 5. In the AV Equipment Room/Rack, Color shall correspond to the following VLANs:
 - a. Crestron/AMX/Extron AV distribution/control – black
 - b. IP / Control connections – purple
 - c. Audio Networks – blue
 - d. HDBaseT distribution – grey
 6. For all far-end connections, color shall be black.
 7. Provide the following spares, delivered to the Owner at time of Owner AV Training
 - a. (10) purple 3 foot patch cords
 - b. (10) purple 7 foot patch cords
- C. Product shall be from the same manufacturer as the patch panel manufacturer:
 1. From the following list:
 - a. Belden
 - b. Hubbell
 - c. Leviton
 - d. Ortronics
 - e. Panduit

TELECOMMUNICATIONS REQUIREMENTS

2.9 CATEGORY 6 PATCH CABLES/CORDS

- A. All products in this category shall be from a single reputable manufacturer and comply with Coordination and Warranty requirements per Part 1 of this Section unless otherwise noted.
- B. Requirements
 - 1. Factory-terminated and tested
 - 2. Shall meet requirements for Category 6 of TIA-568-C
 - 3. Provide quantities and lengths as necessary for a complete Audio Video System; coordinate requirements with Division 27 "Audio Video Systems" contractor.
 - 4. In the AV Equipment Room/Rack, Color shall correspond to the following VLANs:
 - a. Crestron/AMX/Extron AV distribution/control – black
 - b. IP / Control connections – purple
 - c. Audio Networks – blue
 - d. HDBaseT distribution – grey
 - 5. For all far-end connections, color shall be black.
 - 6. Provide the following spares, delivered to the Owner at time of Owner AV Training
 - a. (10) white 3 foot patch cords
 - b. (10) white 7 foot patch cords
- C. Product shall be from the same manufacturer as the patch panel manufacturer:
 - 1. From the following list:
 - a. Belden
 - b. Hubbell
 - c. Leviton
 - d. Ortronics
 - e. Panduit

2.10 COPPER ENTRANCE PROTECTION

- A. General
 - 1. Fully protect each end of all incoming conductors which are considered to have lightning exposure in accordance with NEC chapter 8.
- B. Category 6 Surge Protection
 - 1. General
 - a. Shall meet UL 497
 - b. Shall exceed TIA/EIA 568 Category 6 performance standards
 - c. Shall be capable of being used with POE+ applications
 - 2. Wall-mount Protectors – for single cables, where quantity of cables in Equipment Room needing protection is 6 or less

TELECOMMUNICATIONS REQUIREMENTS

- a. Manufacturer shall be:
 - 1) Emerson Edco CAT6-POE
 - 2) ITWLinx SurgeGate Series CAT6-75
- 3. Rack-mount Protectors – where more than 6 cables in an Equipment Room require surge protection
 - a. Shall be rack-mountable in 19” wide equipment rack
 - b. Provide quantity of Category 6 protectors/modules required for install, plus 25% spare
 - c. Manufacturer shall be:
 - 1) APC ProtectNet Chassis (PRM24) with Cat 6 Surge Modules (PNETR6)
 - 2) Emerson Edco RM-CAT6-**POE
- 4. Far-end Protection – exterior Category 6 outlets should have integral protection against power surges and transients. Where AV equipment does not have integral protection, provide the following at the far-end of each exterior Category 6 outlet:
 - a. Blackbox CAT6 In-Line Surge Protector
 - b. Emerson CAT6-5POE-FF

2.11 OPTICAL FIBER BACKBONE CABLING

- A. All fiber cables shall be from a single reputable manufacturer and comply with Coordination and Warranty requirements per Part 1 of this Section unless otherwise noted.
- B. Manufacturer shall be:
 - 1. From the following list, subject to Coordination and Warranty requirements:
 - a. Superior Essex
 - b. Belden
 - c. Berk-Tek
 - d. Hitachi
 - e. Hubbell
 - f. Mohawk
 - g. Panduit
- C. Requirements:
 - 1. Cable shall meet the transformation performance and physical specifications of ANSI/TIA/EIA-568.
 - 2. Type shall be Singlemode (SM)
 - 3. Refer to drawings for strand counts and locations - minimum strand count of 12 and in multiples of 12 strands.
 - 4. Cable jacket marking: Shall be legible and shall contain the following information:
 - a. Manufacturer’s name and trade mark
 - b. Fiber size
 - c. Fiber Grade
 - d. UL listing (Shall be suitable for the application)
 - e. Sequential length markings

TELECOMMUNICATIONS REQUIREMENTS

D. Backbone cables for dry environments

1. Requirements

- a. Tight-buffered construction
- b. Cable shall have an overall armor of steel or aluminum
- c. Where all backbone cables are to be installed in conduit from AV Equipment Rack/Room to AV Equipment Rack/Room, cable shall be riser (CMR or MPR) rated. Where any portion of any backbone cable is routed in an air plenum space, all backbone cable shall be plenum (CMP) rated.

2. Manufacturer shall be:

- a. Submit product data

E. Backbone cables for Wet Locations and Environments

1. Requirements

- a. Cable jacket shall be suitable for installation in standing water.
- b. Where backbone conduits do not enter building directly in AV Equipment Room, cable jacket shall carry additional rating based on pathway conditions:
 - 1) If pathway is via a return air plenum – additionally plenum rated jacket.
 - 2) If pathway is not via a return air plenum – additionally riser rated jacket.
- c. Cable shall have an overall armor of steel or aluminum.
- d. Tight-buffered or loose-tube construction.

2. Manufacturer

- a. Submit product data

2.12 OPTICAL FIBER HORIZONTAL CABLING

A. All fiber cables shall be from a single reputable manufacturer and comply with Coordination and Warranty requirements per Part 1 of this Section unless otherwise noted.

B. Manufacturer shall be:

1. From the following list, subject to Coordination and Warranty requirements:

- a. Superior Essex
- b. Belden
- c. Berk-Tek
- d. Hitachi
- e. Hubbell
- f. Mohawk
- g. Panduit

C. Requirements:

- 1. Cable shall meet the transformation performance and physical specifications of ANSI/TIA/EIA-568.

TELECOMMUNICATIONS REQUIREMENTS

2. Type shall be Singlemode (SM) or OM3/OM4 Multimode (MM) as identified on the drawings
3. A minimum of 2 strands as identified on the drawings
4. Cable jacket marking: Shall be legible and shall contain the following information:
 - a. Manufacturer's name and trade mark
 - b. Fiber size
 - c. Fiber Grade
 - d. UL listing (Shall be suitable for the application)
 - e. Sequential length markings
5. Cable shall have an overall armor of steel or aluminum

D. Horizontal cables for dry environments

1. Requirements
 - a. Cable jacket shall be at a minimum riser (OFNR | OFCR) rated. Where any portion of the cable is routed in an air plenum space, cable jacket shall be plenum (OFNP | OFCP) rated.
2. Cable jacket color shall be:
 - a. Yellow for singlemode fiber optic cable
 - b. Aqua for OM3 fiber optic cable
 - c. Violet for OM4 fiber optic cable
3. Manufacturer
 - a. Submit product data

E. Horizontal cables for Wet Environments

1. Requirements
 - a. Cable jacket shall be suitable for installation in such environments as follows:
 - 1) Where pathway enters building in the AV Equipment Room or within 50' of AV Equipment Room - outside plant only.
 - 2) Where pathway enters building and does not travel in an air plenum space – indoor/outdoor riser.
 - 3) Where pathway enters building and travels in an air plenum space – indoor/outdoor plenum.
 - b. Cable jacket rating shall be consistent with manufacturer's requirements to be covered under warranty specified.
2. Manufacturer
 - a. Submit product data

2.13 OPTICAL FIBER CONNECTIVITY

A. General Requirements:

1. All products in this category shall be from a single reputable manufacturer and comply with

TELECOMMUNICATIONS REQUIREMENTS

- Coordination and Warranty requirements per Part 1 of this Section unless otherwise noted.
2. Refer to drawings for faceplate and connector locations and types.
 3. All strands shall be terminated/spliced, with any unused strands labeled as "SPARE".

B. Rack-mount Fiber Enclosure (Patch Panel)

1. Requirements:
 - a. Refer to drawings for enclosure locations.
 - b. Height shall be 2RU
 - c. Shall fit into a standard 19 inch-wide equipment rack
 - d. Front and rear access
 - e. Complete with all necessary cable clamps, couplings and connector bulkheads.
 - f. Integral flip-down translucent front cover, with space reserved for labels
 - g. Include splice trays in back of enclosure. Quantity of trays to support the quantity of all horizontal and backbone cable strands entering enclosure, including un-used/dark strands.
2. Manufacturer shall be from the following list, subject to Coordination and Warranty requirements:
 - a. Belden FiberExpress Series
 - b. Corning Cable Systems CCH Series
 - c. Hubbell OptiChannel Series
 - d. Leviton Opt-X 1000i Series
 - e. Ortronics OptiMo FC Series Fiber Patch and Splice Cabinets
 - f. Panduit Opticom Series

C. Adapters / Modules

1. Requirements:
 - a. Shall fit into Rack-Mount Fiber Enclosure
 - b. Shall include factory-terminated pigtailed (2 meters in length)
 - c. Fiber connector type shall be as coordinated with Owner
 - d. Connector quantity shall support the quantity of all horizontal and backbone cable strands entering enclosure, including un-used/dark strands.
 - e. Quantity of Adapters / Modules shall support all required connector quantity.
2. Manufacturer
 - a. Shall be same manufacturer as Fiber Enclosure
 - b. Submit product data

2.14 OPTICAL FIBER PATCH CABLES/CORDS

A. Requirements

1. Factory-terminated
2. Shall meet requirements of TIA-568-C
3. Provide quantities and lengths as necessary for a complete Audio Video System
4. Provide the following spares, delivered to the Owner at time of Owner Training
 - a. (5) 3 foot patch cords

TELECOMMUNICATIONS REQUIREMENTS

- b. (5) 7 foot (2 meter) patch cords

B. Product shall be:

- 1. Manufacturer shall be the same as the rack-mount enclosure manufacturer.

2.15 COPPER TESTING EQUIPMENT

A. The following Test Equipment is Conditionally Approved for Contractor use.

1. Category 6 Cable Tester

- a. Available Manufacturers. Contractor may submit other cable testers that meet specification requirements.
- b. Category 6 Cable Tester
 - 1) Fluke www.flukenetworks.com
 - 2) Greenlee www.greenlee.com
 - 3) Ideal www.idealindustries.com
 - 4) JDSU www.jdsu.com

2. Requirements

- a. The field tester shall be a level III or greater.
- b. The field tester shall meet the requirements of TIA-568.

B. Category 3 Cable Tester

1. Available Manufacturers. Contractor may submit other cable testers that meet specification requirements.

- a. Category 3 Cable Tester
 - 1) Fluke www.flukenetworks.com
 - 2) Greenlee www.greenlee.com
 - 3) Ideal www.idealindustries.com
 - 4) JDSU www.jdsu.com

2. Requirements

- a. The field tester shall meet the requirements of TIA-568.

2.16 FIBER TESTING EQUIPMENT

A. The following Test Equipment is Conditionally Approved for Contractor use.

B. Optical Time Domain Reflectometer (OTDR)

1. Available Manufacturers. Contractor may submit other cable testers that meet specification requirements.

- a. Fluke

TELECOMMUNICATIONS REQUIREMENTS

- b. Ideal
- c. JDSU

2. Requirements

- a. An OTDR shall be used to provide Tier Two testing, which shall provide information regarding attenuation, connector location and insertion loss, splice location and splice loss, and any other power loss events that may have been created during installation.
- b. The OTDR shall be utilized from both ends of the fiber strand to better isolate any potential problems.

C. Optical Power Measurement Meter

1. Available Manufacturers. Contractor may submit other cable testers that meet specification requirements.

- a. Fluke
- b. Ideal
- c. JDSU

2. Requirements

- a. An Optical Loss Test Set (OLTS) shall be used to provide Tier One testing, which shall provide information regarding link attenuation, continuity, and polarity of the installed fiber optic cable.
- b. The OLTS shall be used with the appropriate adapters to allow connectivity to the optical fiber link.
- c. The OLTS shall meet the launch requirements of ANSI/TIA-455-78B.
- d. Optical Fiber Inspection Scope

3. Available Manufacturers. Contractor may submit other cable testers that meet specification requirements.

- a. Fluke
- b. Ideal
- c. JDSU

4. Requirements

- a. An Optical Fiber Inspection Scope shall be utilized to examine all ends of fiber optic strands prior to splicing or termination.
- b. The Optical Fiber Inspection Scope shall have a minimum of 400x magnification. If the cable and/or connectivity manufacturer requires greater magnification to meet their installation requirements, the more restrictive standard shall apply.

PART 3 - EXECUTION

3.1 CABLE INSTALLATION

A. General

- 1. Install each cable as an uninterrupted conductor section between the designated termination points,

TELECOMMUNICATIONS REQUIREMENTS

unless otherwise directed by the cable installation specifications.

- a. There shall be no splices or mechanical couplers installed between the cable points of origin and termination except as shown on the Drawings and/or specified herein.
 - b. No horizontal Category 6 cables shall exceed the allowed maximum distance of 295 feet (90 meters) by TIA-568-C.
2. Unless otherwise noted, all cables shall be routed through the building cable tray/conduit/surface-mounted raceway system.
- a. All horizontal cables shall be suitable for installation in their environment, either plenum (CMP, MPP, OFNP, or OFCP) or riser (CMR, MPR, OFNR, or OFCR) rated, unless otherwise noted.
 - b. Horizontal cables installed in Wet Locations as defined by the NEC or in these construction documents (such as conduits embedded or routed below a ground floor slab) shall be suitable for installation in such environments and follow the installation requirements for outside plant cables as specified herein.
3. Cables shall remain unattached to pathways or other cables and shall simply lay at rest on the supports provided by its pathway (including cable trays, wire basket, j-hooks, conduit, etc.). Wire ties, Velcro straps, electrical tape or any other method shall not be used to attach cables to cable supports or to create cable bundles.
- a. Except when supported by ladder racking within each AV Equipment Room/Rack, UON.
4. At the same time horizontal cables are pulled into a conduit also install a pull cord to facilitate future cable pulls along those. Use polypropylene or monofilament plastic line with not less than 200 lb. (90.72 kg) tensile strength. Leave at least 12 inches (304.8 mm) of slack at each end of pull cord.
5. Do not install kinked, scored, deformed, or abraded cable. Remove and discard cable if damaged during installation and replace it with new cable
6. Comply with all referenced standards and guidelines.
7. Cables shall be masked, covered, or otherwise protected from being painted or coming in contact with any other substance that may degrade the performance or physical characteristics of the cable jacket or insulation over time.
8. Where distance allows all horizontal cables shall be provided with slack/service loops at each end of the cable, one at the device (if not in conduit) and one at the equipment room/enclosure. Each slack/service loop shall be:
- a. A minimum of 8 feet (2.44 meter) in length, UNO
 - b. Configured in a loosely formed figure eight configuration (i.e.. not coiled)
9. Use of any cable pulling lubricants is prohibited.
- a. Where lubricant is deemed necessary by the contractor to facilitate installation of cable in conduit, submit RFI with explanation, effected conduit run, proposed lubricant type, letter from cable manufacturer indicating proposed lubricant will not damage or degrade cable, and a letter from the manufacturer providing the Advanced System Warranty (if applicable) that the use of this lubricant will not exclude that cable run from the required warranty.
- B. Outside plant cable installation: for cables placed in Wet or Damp Locations (as defined by the NEC) or as required by these construction documents. (I.e. all cables which extend beyond the footprint/envelope of the building or pathways leading to floor-boxes embedded in a ground floor slab)

TELECOMMUNICATIONS REQUIREMENTS

1. Coordinate installation of conduit serving Wet Locations so conduit stubs up directly into Equipment Room, if practical.
2. If conduit serving Wet Locations cannot be installed so conduit stubs up directly into Equipment Room, utilize IMC or RMC conduit to within 50 feet (15.24 meter) of the cable termination point.
3. No portion of outdoor only (unlisted) cables may be installed with the cable jacket exposed in any plenum or other air handling space nor shall they be allowed to transition between different levels of the building.
4. Where specifically allowed by these construction documents cable jackets rated for dual use by a NRTL, such as an indoor/outdoor rated cable may be used.
 - a. These cables may be installed in locations within the building in which the cable jacket is appropriately rated to meet all applicable building codes.
5. All cables which extend beyond the envelope/footprint of the building or serving outlets/devices on external walls or roofs shall be installed with entrance protectors in accordance with this section.

C. Fiber Splices

1. In general, optical fiber cables shall not to be spliced except where indicated otherwise in the Drawings and Specifications.
2. Where splicing is indicated in the Drawings and Specifications, multi-mode and single-mode optical fiber cable splicing shall be fusion spliced.
3. In the Communications Room / at the Equipment Rack, instead of field terminating the optical fiber cables onto appropriate type connectors, splice the optical fiber cables near their termination points to connectors that have been factory pre-terminated with optical fiber pig-tails. The following requirements apply to the use of this termination approach:
 - a. All Multi-mode and single-mode optical fiber strands shall be spliced to factory pre-terminated pig-tails with matching fiber type/diameter.
 - b. Rack mounted splice tray enclosures shall be by the same manufacturer as the optical fiber connector panels.
 - c. Trays shall be used to hold all splices.
 - d. Optical fiber cables shall be labeled at the splice trays.

3.2 CONNECTOR INSTALLATION

- A. Furnish and install all cable connectors as shown on the Drawings.
- B. Provide number of connectors as required by the Drawings and as required by these documents, where the number of connectors required does not fill the entire faceplate provide blank inserts so that no opening is left.
- C. The provision and termination of connectors from each cable shall be done as follows:
 1. Where connector types are identified on the applicable drawings or in the specifications, furnish and install the specified connectors on the specified cables. Installation of the connectors shall be in accordance with the manufacturer's printed instructions.
 2. All installed connectors, regardless of type, method of procurement or permanency, shall be adequately protected during and after installation.

TELECOMMUNICATIONS REQUIREMENTS

D. Copper Connector Installation

1. Terminate all four pairs of each cable on one outlet jack. Ensure shield/foil and drain wire are properly installed according to manufacturer's instructions.
2. Furnish and install all cable connectors as shown on the Drawings or as indicated herein, unless otherwise noted.
3. The provision and termination of connectors for each cable shall be done as follows:
 - a. Where connector types are identified on the applicable drawings or in the specifications, Furnish and install the specified connectors on the specified cables. Installation of the connectors shall be in accordance with the manufacturer's printed instructions.
 - b. All installed connectors, regardless of type, method of procurement or permanency, shall be adequately protected during and after installation.

E. Fiber Optic Connector Installation

1. In the Equipment Room, all fiber optic cable strands shall be fusion-spliced to factory-terminated pigtailed adapters.
2. At device end, terminate/splice all fiber optic cable strands as shown on the Drawings.
3. All fiber optic connectors shall be installed with dust caps/covers.

3.3 FACEPLATE INSTALLATION

- A. Furnish and install all faceplates in locations as shown on the Drawings.
1. Where co-located on AV faceplates, coordinate installation with Division 27 "Audio Video Systems" contractor.

3.4 CABLE IDENTIFICATION

- A. Label all cabling with machine-printed labels according to the labeling scheme identified on the drawings. If the drawings do not address labeling scheme, submit RFI through appropriate channels requesting labeling scheme.
1. Shop drawings shall include floor plan that indicates proposed cable/outlet identification for each outlet.
- B. Cables shall be labeled within 6" at each end.
- C. All cable labels shall be thermal-transfer type and utilize self-adhesive labels. The following are approved manufacturers:
1. Brady, IDXPRT
 2. Hellermann Tyton, Spirit 2100
 3. Panduit LS9
 4. Or Approved Equivalent

3.5 ENTRANCE PROTECTION INSTALLATION

- A. Install grounding wire as straight as possible from protector to the Technical System Ground.

B. Grounding and bonding

1. Bond all metallic shields and armored jacketing material for all incoming cables as close as practicable to the entry into the building.
2. Bonding conductors shall be connected to the Technical System Ground and in accordance with NEC chapter 8.

3.6 GENERAL CABLE TESTING

A. Pre-installation testing:

1. Visually inspect all cables, cable reels/boxes, and shipping cartons to detect cable damage incurred during shipping and transport. Return visibly damaged items to the manufacturer.
2. Mark reels or boxes as tested/inspected.
3. Do not install any cable with less than the manufacturer's guaranteed number of serviceable conductors.
4. The field-test instruments shall be within the calibration period recommended by the manufacturer and shall contain the most recent software and firmware provided by the manufacturer prior to testing.

B. Post-installation testing:

1. Conduct cable testing as described below upon completion of installation. Test fully completed systems only. Piecemeal testing is not acceptable.
2. Provide testing in accordance with manufacturer's requirements for a fully warrantied cabling system(s) as required by these Contract Documents.
3. All outlets, cables, patch panels, and associated components shall be fully assembled and labeled prior to field testing.
4. Invite the Owner and Design Consultant to witness, review, or both witness and review field-testing.
 - a. The Owner and the Design Consultant shall be notified of the testing start date (2) weeks before testing commences.
5. Remove all defective cables from pathway systems.
6. All cables that fail testing are to be corrected prior to substantial completion and acceptance by owner. Replace entire cable if bad pair or conductor is found. Do not abandon cables in place.

C. All test results and corrective procedures are to be documented and submitted to the Design Consultant as part of the Project Completion submittal(s) and the Contractor's Testing and Adjustment requirements of Division 27 Section "Audio Video Systems".

1. Submit updated Record Drawings along with completed Test Results. Record Drawings shall have final outlet labels that correspond to the identification used in the Test Results.
2. Format of test results shall be:
 - a. Electronic Database Test Results - Abbreviated results, in PDF and Excel/CSV file formats, shown in numerical / alphabetical order in a spreadsheet which depicts the following:
 - 1) Project Name
 - 2) Date of Preparation
 - 3) ID of Work Area Outlet / connector being tested
 - 4) Date of test

TELECOMMUNICATIONS REQUIREMENTS

- 5) Contractor's Name
- 6) Media Type
- 7) Make, Model and Serial Number of test equipment used
- 8) Date of Last Calibration
- 9) Names of Test Crew
- 10) Serving Communications Room Number
 - a) All tests shall be submitted in numerical / alphabetical order by Communications / Equipment Room.
- 11) Category of cable being tested
- 12) Abbreviated Test Results depicting Pass, Fail status
- b. Full Test Results – test results saved within the field-test instrument and then transferred into a Windows-based database utility that allows for the maintenance, inspection, and archiving of the test records, shown in numerical / alphabetical order in the file format of the tester (example: .mdb file, and unaltered.
 - 1) Project Name
 - 2) Date of Preparation
 - 3) ID of Work Area Outlet / connector being tested
 - 4) Date of test
 - 5) Contractor's Name
 - 6) Media Type
 - 7) Make, Model and Serial Number of test equipment used
 - 8) Date of Last Calibration
 - 9) Names of Test Crew
 - 10) Serving Telecommunications Room Number
 - a) All tests shall be listed in numerical / alphabetical order by Communications / Equipment Room.
 - 11) Category of cable being tested
 - 12) Full Test Result data

D. Final Acceptance Review

1. Final Acceptance Review will take place in conjunction with the Design Consultant Commissioning as specified in Division 27 Section "Audio Video Systems". Final Acceptance Review cannot take place until Design Consultant receives Test Results and Record Drawings.
2. Provide a minimum of two suitably qualified cabling/testing technicians to be present on-site for a period of two hours during the scheduled Final Acceptance Review. Be prepared to conduct on-the-spot cable tests.
3. During the Final Acceptance Review, the Owner or the Design Consultant may select a random sample of up to 10% of the installed links for the Contractor to retest. The measured results obtained from the random sample shall be compared to the Test Results provided by the Contractor.
4. If 10% or more of the randomly tested cables differ in terms of the pass/fail determination or in cable length, the Owner and Design Consultant reserve the right to require a re-testing of 100% of the cable plant by a third-party at the Contractor's expense.
5. Successful equipment performance tests do not relieve the Contractor from the specified testing, repair, and documentation requirements.

3.7 COPPER CABLE TESTING

- A. Perform all manufacturer recommended and required test calibration procedures prior to testing any cables.

TELECOMMUNICATIONS REQUIREMENTS

B. Four-Pair Cables:

1. After terminating both ends of all 4-pair cables, but before any cross-connects are installed, test these cables for the following:
 - a. Category 6
 - 1) Wire map
 - 2) Length
 - 3) Insertion loss
 - 4) Near-end crosstalk (NEXT) loss.
 - 5) Power sum near-end crosstalk (PSNEXT)
 - 6) Equal-level far-end crosstalk (ELFEXT)
 - 7) Power sum equal-level far-end crosstalk (PSELFEXT)
 - 8) Return loss
 - 9) Propagation delay
 - 10) Delay skew
 - 11) Alien Crosstalk (AXTalk) – Follow manufacturer’s instructions for method

C. Two-Pair Cables:

1. After terminating both ends of all 2-pair cables, but before any cross-connects are installed, test these cables for the following:
 - a. Category 3
 - 1) Wire map
 - 2) Length
 - 3) Insertion loss
 - 4) Return loss
 - 5) Propagation delay

- D. All installed cabling Permanent Links shall be field-tested and pass the test requirements and analysis above. Any Permanent Link or Modified Permanent Link that fails these requirements shall be diagnosed and corrected. Any corrective action that must take place shall be documented and followed with a new test to prove that the corrected Permanent Link meets performance requirements. The final and passing result of the tests for all Permanent Links shall be provided in the test results documentation.

3.8 OPTICAL FIBER CABLE INSTALLATION

A. General:

1. Place all optical fiber cabling in accordance with these specifications, and as indicated on the Drawings.
2. Splices between optical fiber cables are permitted only at those locations indicated on the Drawings.

B. Comply with all referenced standards and guidelines.

C. Pre-installation testing:

1. Optical fiber cables: Perform visible light continuity check on each fiber. If one end is not accessible: perform OTDR test to assure fiber continuity.

3.9 OPTICAL FIBER CABLE TESTING

A. Post-installation Optical Loss testing:

1. After installation of connectors, visually inspect each fiber end-face at 50X magnification. Refinish fibers with visible defects and/or striations in the core area.
2. Perform end-to-end, bi-directional attenuation (loss) test for each fiber strand at 850nm and 1300nm. Conduct tests in accordance with EIA/TIA-526-14, Method B and with test instrument manufacturer’s printed instructions.
3. Perform end-to-end, bi-directional attenuation (loss) test for each fiber strand at 1310 and 1550 (single mode) wavelengths. Conduct tests in accordance with EIA/TIA-526-7, Method A.1 and with test instrument manufacturer’s printed instructions.
4. Demonstrate that measured link loss does not exceed the “worst case” allowable attenuation loss. Calculate worst case allowable attenuation loss by:
 - a. Utilizing the following formulas as specified in ANSI/TIA-568-C.0:
 - 1) Link Attenuation (dB) = Cable_Attn (dB) + Connector_Attn (dB) + Splice_Attn (dB)
 - 2) Cable_Attn (dB) = Attenuation_Coefficient (dB/km) * Length (km)
 - 3) Connector_Attn (dB) = number_of_connector_pairs * connector_loss (dB)
 - 4) Maximum allowable connector_loss = 0.75 dB
 - 5) Splice_Attn (dB) = number_of_splices * splice_loss (dB)
 - 6) Maximum allowable splice_loss = 0.3 dB
 - 7) The values for the Attenuation_Coefficient (dB/km) are listed in the table below:

Type of Optical Fiber	Wavelength (nm)	Attenuation coefficient (dB/km)	Wavelength (nm)	Attenuation coefficient (dB/km)
Multimode 62.5/125 μm	850	3.5	1300	1.5
Multimode 50/125 μm	850	3.5	1300	1.5
Single-mode (Inside plant)	1310	1.0	1550	1.0
Single-mode (Outside plant)	1310	0.5	1550	0.5

5. Strands whose measured attenuation fall outside the acceptable range shall be subject to further inspection and testing to determine the nature of the fault. At a minimum, the OTDR shall be used to: determine the true loss for each connector pair, the exact length of the fiber and to identify the presence of any core damage.
6. Faults related to fiber being connectorized shall be corrected, and the fiber re-tested as described above, until acceptable attenuation measurements are recorded.
7. Where defects are found to be inherent in the fiber itself: replace any cable having fewer than the manufacturer’s guaranteed number of serviceable fibers.
8. Dust caps shall be placed on fiber endfaces or adapters for each optical fiber link after all testing is complete on the fiber link.

B. Testing jumpers used shall remain connected at the test equipment for the entire duration of testing. If at any time the jumper becomes loose or removed, for any reason, the jumper shall be reinstalled and re-referenced. This procedure shall be documented each time it is performed to indicate date, time and who performed the procedure. This log shall accompany test reports submitted.

C. All test results and corrective procedures are to be documented and submitted to the Owner and Design Consultant a minimum of 1 week prior to the Final Acceptance Review / Design Consultant Commissioning Trip (as specified in Division 27 Section “Audio Video Systems”).

TELECOMMUNICATIONS REQUIREMENTS

3.10 ACCEPTANCE

- A. All Work in this section is subject to the Project Completion and Schedule requirements of Division 27 section "Audio Video Systems".
- B. After Final Acceptance Review:
 - 1. Complete all Punch List items.
 - 2. Retest effected cables.
 - 3. Among other requirements, submit updated and complete Record Drawings/Test Results as part of Division 27 Audio Video Systems – Operation and Maintenance Data Submittal.

END OF SECTION 274110

SECTION 274116 - AUDIO VIDEO SYSTEMS EQUIPMENT

PART 1 - GENERAL

1.1 SUMMARY

- A. These specifications and the associated TA-series drawings describe the requirements for the sound system (hereafter referred to as the "Technical System").
- B. Refer to Division 27 Section "Audio Video Systems" for additional information.

1.2 RELATED DOCUMENTS

- A. Drawings and general provisions of the Contract, including General and Supplementary Conditions and Division 1 Specification Sections, apply to this Section, as do the following:
 - 1. Division 27 Section "General Communications Requirements".
 - 2. Division 27 Section "Common Work Results for Communications".
 - 3. Division 27 "Audio Video Systems".
- B. All Category 5e/6 and fiber optic cabling and terminations shall adhere to the Division 27 Section "Telecommunications Requirements for Audio Video Systems".

1.3 QUALITY ASSURANCE

- A. Refer to Division 27 "Audio Video Systems" for quality assurance requirements with the following modifications:
 - 1. Contractor General Qualifications:
 - a. Active membership in the National Systems Contractors Association (NSCA).
 - b. Active membership in InfoCommthe Audiovisual and Integrated Experience Association (AVIXA).
 - c. Authorized dealer for major components of Technical System. Major components include: mixing consoles, loudspeakers, power amplifiers, and Digital Signal Processors.
 - 2. Contractor Personnel Qualifications:
 - a. Minimum of one full-time staff member who has attended technical system engineering courses taught by Syn-Aud-Con in the past 10 years.
 - b. Minimum of one InfoComm AVIXA CTS-I (Certified Technology Specialist - Installation) systems technician.
 - c. Minimum of one full-time staff member who has a minimum of three (3) years direct experience with and is factory-certified on the most recent version of the selected Digital Signal Processor (DSP) software and technology. This individual shall be responsible for the implementation of the DSP system including software. This individual shall be the same throughout the execution of the work unless illness, loss of personnel, or other reasonable circumstances intervene.
 - d. Minimum of one full-time staff member who has a minimum of three (3) years direct

experience with network based-AV transport and is factory-certified on the most recent version of the selected AV transport technology. The individual shall hold a current manufacturer's certification (i.e., Crestron DMC-E). This individual shall be responsible for the implementation and preliminary commissioning of the AV transport system. This individual shall be the same throughout the execution of the work unless illness, loss of personnel, or other reasonable circumstances intervene.

- e. Minimum of one full-time staff member who has a minimum of three (3) years direct experience and is a factory certified Master Level Programmer on the most recent version of the AV control system software and technology. This individual shall be the same throughout the execution of the work unless illness or loss of personnel intervenes. A factory authorized independent programmer (i.e., Crestron Master CAIP) will also be accepted, providing the programmer meets the criteria identified in this paragraph.

1.4 SUBMITTALS

- A. Refer to requirements in Division 27 Section "General Communications Requirements".
- B. Refer to Division 27 Section "Audio Video Systems" for submittal requirements with the following alterations and additions:
 - 1. Pre-Construction
 - a. Schedule specific items include:
 - 1) Off-site: touch screen layouts, DSP configuration
 - 2) On-site under scope: rack installation, loudspeaker installation
 - 3) On-site other scope: completion and securable millwork/control booth
 - b. Structural Details: specific to loudspeakers.
 - c. Signal Flow Shop Drawings – One-line diagrams indicating full intended system configuration. Any generic diagrams found within the Construction Documents shall be drawn to specific requirements. Alterations from basis of design found within the Construction Documents shall be reflected and identified.
 - d. DSP Signal Flow - DSP signal flow configuration (submitted within at least three months sufficient review time prior to system first use).
 - e. Millwork Shop Drawings - Sound console and mobile cart millwork details, and related equipment and panel layout.
 - f. AV Control System - AV control system panel/screen layouts suitable for the Owner's Representative to understand the operation and flow (submitted within at least five months sufficient review time prior to system first use).
 - 2. Project Completion
 - a. Refer to Division 27 Section "General Communications Requirements" and the Operation and Maintenance Data section in Part 3 of this section for additional requirements.

1.5 EXISTING AND/OR OWNER-FURNISHED EQUIPMENT

- A. Refer to Division 27 Section "Audio Video Systems" for general Existing and/or Owner-Furnished Equipment requirements.

PART 2 - PRODUCTS

2.1 GENERAL

- A. Refer to Division 27 Section “Audio Video Systems” for general product requirements.
- B. All major components of technical system equipment shall be provided and installed by a qualified contractor as outlined in Part 1 of this section.
- C. All electronic audio devices shall have electronic or transformer balanced inputs and outputs except for specific program source equipment and specific mixing console inputs and/or outputs. If an electronic device specified or furnished has an unbalanced input and/or output, make provisions to balance said input/output (i.e., active signal balancing device as approved) unless other arrangements have been agreed upon with the Design Consultant.

2.2 COMMON EQUIPMENT

- A. Refer to Division 27 Section “Audio Video Systems” for common equipment and components.

2.3 MICROPHONES – PORTABLE

- A. Microphone – Single Ear Headworn: headworn omnidirectional microphone, condenser, for wireless beltpack transmitter, lightweight, single over-the-ear style. Coordinate connector to mate with beltpack, color as selected by Owner’s Representative:
 - 1. Avlex HSP-50 microphone (quantity twelve required); or
 - 2. Approved equal.
- B. Microphone – Handheld PTT: dynamic announce microphone with internal press-to-talk switch. Furnish each with mounting clip. Mounting clip located as later directed by Design Consultant. Install male XLR connector on the end of the microphone cable. Connect the pushbutton switch so that the microphone circuit is normally-shortcircuit (quantity required)
 - 1. Astatic 611L; or
 - 2. Shure 514B; or
 - 3. Approved equal.
- C. Wireless Microphone Beltpack Transmitter holder: transmitter holder and elastic bands for wearing on waist, leg, or arm; tan color:
 - 1. Wireless Mic Belts (wirelessmicbelts.com) Belt Pac Series with:
 - a. 20 WMB Belts Package (one required total); and
 - b. WMB Belt – 16” Thigh (four required total); and
 - c. WMB Belt – 20” 2XSmall (four required total); and
 - d. WMB Belt – 24” XSmall (four required total); or
 - 2. Approved equal.

2.4 WIRELESS MICROPHONE SYSTEMS

- A. Furnish complete UHF diversity wireless microphone system(s) including the following components (select components from one manufacturer listed below):
- B. Wireless Microphone Receiver: furnish single, dual, or quad channel models with rack mount kits as required to achieve the number of receiver channels as shown on the drawings:
 - 1. Shure ULXD4 (single channel), or ULXD4D (dual channel), or ULXD4Q (four channel) digital wireless receiver with encryption capability (encryption must be off when one receiver shares more than one transmitter) with included rack mount kit; or
 - 2. Approved equal.
- C. Wireless Beltpack Transmitter: furnish beltpack transmitter with headworn microphone (quantity required):
 - 1. Shure ULXD1 with headworn microphone as specified elsewhere; or
 - 2. Approved equal.
- D. Wireless Handheld Transmitter – Dynamic (quantity 2 required):
 - 1. Shure ULXD2 with RPW118 (Beta 58A) head, 95T9279 microphone clip (included), and A58WS windscreen; or
 - 2. Approved equal.
- E. Wireless In-Line RF Amp: RF amplifier powered from wireless microphone receiver or antenna distribution amplifier:
 - 1. Sennheiser AB3 series in-line RF amplifier; or
 - 2. Shure UA830USTV line amplifier; or
 - 3. Approved equal.
- F. Wireless Antenna DA: active antenna distribution system supporting up to four receiver inputs, terminate all unused output ports:
 - 1. RF Venue 4 Channel Antenna Distributor; or
 - 2. Sennheiser ASA1/NT Antenna Distribution System; or
 - 3. Shure UA844SWB four-way active antenna splitter; or
 - 4. Approved equal.
- G. Wireless Remote Antenna: omnidirectional ½-wave remote mounted antenna:
 - 1. Sennheiser A1031-U Omni-directional Antenna; or
 - 2. Shure UA8 Omni-directional Antenna; or
 - 3. Shure UA860SWB (470-1100 MHz; weather resistant); or
 - 4. Approved equal.
- H. Wireless Remote Antenna - Diversity: integrated Dipole and LPDA antenna array, 470 – 698 MHz, forward gain, polarization offset:
 - 1. RF Venue Diversity Fin; or
 - 2. Approved equal
- I. Wireless rechargeable battery system – main position: including batteries, chargers, and power supplies to charge all transmitters simultaneously. Label each battery using a logical scheme so batteries can be

tracked as they are shuffled among transmitters. Document labels into a spreadsheet which will become a portion of the Operation & Maintenance manuals described in Part 3 of these specifications. Secure chargers to base of drawer using Velcro™ (one rechargeable battery and associated charging slot required for each transmitter furnished):

1. Shure SB900A battery, SBC200-US dual charger with power supply, SBC200 dual charger expansion, SBC800-US Eight Battery Charging Station; or
 2. Approved equal.
- J. Each receiver shall be connected via Ethernet to the computer. Furnish the most recent configuration software, install on the computer, and configure each receiver and transmitter for optimum operation. Test each and all receiver/transmitters to ensure no problems arise.
- K. Where remote 1/4 wavelength antennas are used, and mounting conditions allow, mount each antenna on a standard metal wall plate to serve as a ground plane.
- L. Provide all connections and components necessary for proper operation of the wireless systems described above.
- M. Coordinate the selection of transmitter/receiver frequencies to be free of interference from outside sources or interference between wireless systems. Select the frequency from an unused channel between (470 - 698 MHz) per FCC regulations Part 74, subpart H.
- N. Label each receiver/transmitter combination as noted on the drawings. See Labeling and Placards section in this specification for additional labeling requirements.

2.5 PROGRAM SOURCE EQUIPMENT

- A. Some of the program source equipment specified is consumer-grade equipment. Upon award of a contract, endeavor to procure these items as soon as possible to avoid delays caused by searching for discontinued product(s).
- B. Rack-mount kit for equipment that requires rack mounting but is not provided with rack mount ears or optional rack mount kit:
1. Lowell RMK series; or
 2. Middle Atlantic Products RSH series; or
 3. Approved equal.
- C. For each portable item of program source equipment, furnish one set of input/output cables (6-foot minimum length) and adapters (as required) to allow connection to technical system inputs/outputs.
- D. CD Player 1RU: networked single-disc player, single rack space, with XLR balanced output connectors, IR, RS-232 and Ethernet control:
1. Denon DN-700C; or
 2. Approved equal.

2.6 MIXING CONSOLES - DIGITAL

- A. The drawings reflect specific mixing consoles. If a mixing console different from the mixer shown on the drawings is furnished, shop drawings are required indicating proposed wiring configuration, patch panel configuration, patch panel labeling, and any modifications to the console millwork. All of the features

shown for the console on the drawings shall be maintained with the substitute mixer.

- B. Control Surface – Console – DC64/27/2/4: digital, mixing console control surface with sixty-four mic/line inputs minimum, twenty seven output busses minimum, two expansion card slots, and four operating layers:
 - 1. Yamaha QL-5 with the following options:
 - a. LA1L LED gooseneck lamp, 4-pin XLR connector (two required)
 - b. Most recent version of QL Editor software installed and set up on the computer
 - c. Mixer shall be connected to a UPS on an un-switched AC power circuit; or
 - 2. Approved equal.
- C. Digital Mixer Expansion RM16/8/0/0: digital, 4RU rack-mounted expander with sixteen XLR mic/line inputs minimum, eight XLR outputs, zero AES/EBU outputs, zero expansion card slots:
 - 1. Yamaha Rio1608-D; or
 - 2. Approved equal.

2.7 DIGITAL SIGNAL PROCESSING (DSP)

- A. The AC power cord of the DSP shall be connected to a rack-mount uninterruptible power supply (UPS). Refer to the AC Power section for specific models. The UPS shall be connected to an unswitched (unsequenced) AC power circuit.
- B. The Design Consultant has assembled preliminary schematics for the DSP to determine the needed equipment and processing power required for the project. After award of the contract, contact the Design Consultant for a copy of the files. Embellish the software to represent the final product for the client and submit as a shop drawing.
- C. Create all schematics for the DSP and submit as a shop drawing.
- D. Provide one computer with mouse and system features as recommended and approved by the manufacturer of the DSP system for use during commissioning.
 - 1. If a computer is provided under this specification section for use as a system operation and configuration device, DSP software should be loaded, and computer should be operational during system commissioning.
 - 2. Furnish a wireless 802.11n router and laptop computer configured to allow for wireless control of the DSP during system testing and commissioning if applicable to the facility. Retain ownership of the router and laptop computer.
- E. Password protection shall be included. One password shall be provided to allow operator access to select functions. Another password shall be provided for technical staff to access all aspects of the software.
- F. Furnish all components for a fully functioning digital signal processing system.
- G. DSP system basis of design is shown on the signal flows. Unterminated IO cards should be provided as indicated on the signal flows for future use or additional requirements.
- H. Substitutes to the basis of design will be considered if all features and functionality of the system requirements are met. IO requirements should meet or exceed the quantity of the basis of design. Processing requirements should meet or exceed the basis of design to ensure proper operation of the

system. The following manufacturers are pre-approved substitutes to the basis of design found on the signal flows:

1. QSC Q-Sys with:
 - a. The most recent Q-Sys Designer software; or

2.8 POWER AMPLIFIERS

- A. Power amplifiers in this section shall be by one manufacturer and operated in multi-channel mode to provide a minimum of two amplifier channels within one chassis unless noted otherwise.
- B. All power amplifiers shall have either electronic or transformer balanced inputs, and shall have either stepped input level attenuators or control via software.

Provide perforated metal security cover (type as specified herein) for each amplifier, to cover all front panel controls and AC power switches. Security cover shall not block air-flow for amplifier internal cooling system.

- C. All power amplifiers shall have standby/sleep mode functionality. This functionality should be implemented on a system wide scale to provide a fully controlled power sequencing system. Preferred solution is networked based; if amplifier does not have necessary features via network control, contact closure solution should be utilized. Contact closure solution shall utilize a control system for triggering power state.

1. Upon system shutdown, power amplifiers shall enter standby/sleep mode per manufacturer's functionality.

- D. Power amplifiers are listed by series, with the basis of design model shown on the signal flows. Deviation from the basis of design to an approved substitute will be allowed as follows:

1. Power rating for high impedance (70V) operation shall meet or exceed the basis of design load requirement on the channel. Load shall be calculated based on total power (addition of all loudspeaker tap values) as indicated on the signal flows.
2. Power rating for low impedance operation shall meet or exceed the basis of design load requirement on the channel. Load shall be as indicated on the signal flows.
3. Channel count per chassis should produce most efficient solution of maximum channels vs appropriate power rating.
 - a. Proposed substitute should take into account alterations of audio network requirements, as applicable. Alterations may include the need for additional network infrastructure, including network switches.
 - b. Proposed substitute should take into account alterations of audio system requirements, as applicable. Alterations may include the need for additional digital signal processing infrastructure.
 - c. Proposed substitute should take into account standby/sleep mode functionality. Alterations may include the need for additional network infrastructure or control system infrastructure.
 - d. Proposed substitute should take into account all other parameters, including but not limited to rack requirements and environmental considerations (AC power, thermal dissipation, etc.).
4. Power Amplifier – Type (####)x/(#)N(A)(B)(C)(D)(E)(Q): power amplifier, high (70V) or low impedance operation switchable per output, network control, loudspeaker processing, audio network capabilities, with the following characteristics required as shown on signal flows:
5. QSC CXD-Q Series
 - a. ####x, minimum power rating listed at 8-ohm load, also capable of providing high

- impedance (70V) operation
- b. /#, number of channels per chassis
- c. N, network control capabilities
- d. Q, Q-Sys

2.9 LOUDSPEAKERS – INSTALLED

- A. General loudspeaker requirements:
 - 1. Where visible, paint out or remove the manufacturer's logo on each loudspeaker.
 - 2. Loudspeaker, and related mounting bracket(s) where appropriate, color shall be as selected by the Architect from the available color selection offered from each loudspeaker manufacturer.
 - 3. Utilize the most recent manufacturer-recommended DSP settings if available.
- B. Loudspeaker LA/FR16-2x8"-126, dual line array element, full-range, dual eight-inch two-way loudspeaker, 16-ohm, 120x6 dispersion; provide factory-supplied or factory-recommended suspension hardware as required for each application:
 - 1. Community IV6 1122/05; or
 - 2. Electro-Voice EVA-2082S/126 (black); or
 - 3. Approved equal.
- C. Loudspeaker LA/FR16-2x8"-1220, dual line array element, full-range, dual eight-inch two-way loudspeaker, 16-ohm, 120x20 dispersion; provide factory-supplied or factory-recommended suspension hardware as required for each application:
 - 1. Community IV6 1122/15; or
 - 2. Electro-Voice EVA-2082S/1220 (black); or
 - 3. Approved equal.
- D. Loudspeaker FL8-12"-##, front loaded, twelve-inch, two-way loudspeaker, 8-ohm load, dispersion as indicated on drawings:
 - 1. Community IP8-1122 series; or
 - 2. Electro-Voice EVF1122S/## series; or
 - 3. Approved equal.
- E. Loudspeaker FL8-6"-##, front loaded, twelve-inch, two-way loudspeaker, 8-ohm load, dispersion as indicated on drawings:
 - 1. Community IC6-1062 series; or
 - 2. Electro-Voice EVU1062/## series; or
 - 3. Approved equal.
- F. Loudspeaker HL/S4-1x18", horn loaded subwoofer, 4-ohm load, single eighteen-inch driver:
 - 1. Danley TH-118; or
 - 2. Approved equal.
- G. Loudspeaker FL/R16-2x3"-123, dedicated front fill loudspeaker, low profile surface mount, front loaded, ribbon HF and dual 3-inch MF, two-way loudspeaker, 16-ohm, 120x30 dispersion:
 - 1. Innovox HLA-Stage Lip; or
 - 2. Approved equal.

2.10 ASSISTIVE LISTENING SYSTEM - FM 72MHZ

- A. The transmitter shall be installed in the audio equipment racks and the transmitting antenna shall be remotely mounted/suspended at the location shown on the drawings. The antenna shall be installed in a vertical orientation.
- B. Select interference-free frequencies corresponding to the following initial assignments, subject to revision (as approved) to avoid interference. Permanently and clearly label each receiver to match:
 - 1. Transmitter channel A "Auditorium"
- C. The Assistive Listening System shall include all hardware as required to provide a fully-functional system.
- D. ALS Transmitter 72MHz: assistive listening system transmitter, operates in the 72MHz band:
 - 1. Listen Technologies LT-800-072-1 with LA-326 rack mount kit; or
 - 2. Telex Soundmate ST-300 with RM-S rack mount kit; or
 - 3. Williams Sound PPA T45 with RPK 005 rack mount kit.
- E. ALS Dipole Antenna 72MHz: assistive listening system antenna, coax or dipole, tuned for operation in the 72MHz band:
 - 1. Listen Technologies LA-116 (coax) or LA-122 (telescoping dipole) or LA-123 (helical); or
 - 2. Telex Soundmate HGA-1 (coax); or
 - 3. Williams Sound ANT024 (telescoping dipole) or ANT034 (helical).
- F. ALS Receiver 1CH-72MHz: assistive listening system belt-pack style receiver, tuned for operation in the 72MHz band (quantity as required to comply with ADA requirements [calculated per seating capacity of auditorium in each school]):
 - 1. Listen Technologies LR-400-072 with LA-362 NiMH batteries or LR-4200-072 (iDSP) with LA-365 Li⁺ battery; or
 - 2. Telex Soundmate SR-400 with NiMH batteries; or
 - 3. Williams Sound PPA R38N with BAT 026-2 NiMH batteries.
- G. ALS Ear Speaker: assistive listening system single ear speaker (one required for each receiver furnished):
 - 1. Listen Technologies LA-401; or
 - 2. Telex Soundmate ES-1; or
 - 3. Williams Sound EAR 022.
- H. ALS Headphone: assistive listening system light-weight headphones (two required):
 - 1. Listen Technologies LA-402; or
 - 2. Telex Soundmate HED-2; or
 - 3. Williams Sound HED 021.
- I. ALS Neckloop: assistive listening system neck loop for use with T-coil equipped hearing aids (quantity as required to comply with ADA requirements [calculated per seating capacity of auditorium in each school]):
 - 1. Listen Technologies LA-166 or LA-430 (iDSP); or
 - 2. Telex Soundmate NL-4S; or
 - 3. Williams Sound NKL 001.

- J. ALS Charger: assistive listening system charging case (one charging slot required for each receiver furnished):
 - 1. Listen Technologies LA-317 4-Slot Charging/Carrying Case or LA-423 4-Port (iDSP) USB Charger; or
 - 2. Listen Technologies LA-321, 8-slot Charging/Carrying Case; or
 - 3. Listen Technologies LA-311 16-Slot or LA-380 12-Slot (iDSP) Charging/Carrying Case; or
 - 4. Telex Soundmate BH-200, Charging Station for two receivers; or
 - 5. Williams Sound CHG 3512 PRO 12-Slot Charging/Carrying Case.

- K. ALS Signage: assistive listening system signage notifying occupants that the assistive listening system is available. Mount signage as directed by the Owner's Representative (one required for each entrance to each applicable room):
 - 1. Listen Technologies LA-304; or
 - 2. Telex Soundmate WP-1; or
 - 3. Williams Sound IDP 008.

2.11 PRODUCTION INTERCOM SYSTEM - WIRED

- A. The intercom system equipment shall be supplied from one manufacturer only. Ensure that power supply can operate all intercom equipment without interruption.

- B. Power Supply 2CH, two-channel, single program line input:
 - 1. Clear-Com PS-702; or
 - 2. Approved equal.

- C. Main Station 2CH, two channel integrated power supply, rack mount, program line input:
 - 1. Clear-Com MS-702; or
 - 2. Approved equal.

- D. Speaker Station 1CH, single-channel, with speaker and built-in push-to-talk microphone, mounts in a standard 4 gang box:
 - 1. Clear-Com KB-701; or
 - 2. Approved equal.

- E. Belt Pack 1CH, single-channel production intercom belt pack (eight required):
 - 1. Clear-Com RS-701; or
 - 2. Approved equal.

- F. Single Muff Headset, single-muff production intercom headset (eight required):
 - 1. Clear-Com CC-300; or
 - 2. Approved equal.

2.12 PRODUCTION INTERCOM SYSTEM – WIRELESS 2.4GHZ

- A. The wireless production intercom system can function as a stand-alone system, or can interface with the wired intercom system.

- B. The wireless intercom system equipment shall be supplied from one manufacturer only.
- C. Wireless Production Intercom System 4CH: 2.4GHz, four channel wireless intercom base station transceiver, head sets(5), belt packs (4), batteries (8), and battery charger
 - 1. Clear-Com/HME DX210 system (P/N: CZ115513); or
 - 2. Approved equal.

2.13 A/V CONTROL SYSTEM – GENERAL PROGRAMMING REQUIREMENTS

- A. Refer to Division 27 Section “Audio Video Systems” for general programming requirements with the following revisions and additions:
 - 1. No additional requirements.

2.14 CABLES – FACTORY TERMINATED – PORTABLE

- A. Factory terminated cable assemblies in this section are approved for portable use only.
- B. Portable cable assembly quantities are identified in parenthesis and are required to be furnished in addition to those required for system installation. Portable cable lengths are a minimum not to exceed the maximum acceptable length identified in the cable descriptions below. Where specific lengths are cited adjacent to quantities, these lengths are to be taken as ideal lengths. If a pre-approved model series is not offered in the specific length cited, then the cable length closest to the cited length shall be provided unless the difference is greater than twenty percent. In this case, contact the Consultant for direction.
- C. All cable assemblies must be factory tested and certified.
- D. Microphone Cable – Microphone cables shall be black with colored boot or ring on the male connector as a color code to identify length (colors as identified for each length below). Custom print “PROJECT NAME” and cover with clear heat shrink tubing approximately 6-inches from the male connector or use custom engraving on the male connector. Microphone cable part numbers are custom products.
- E. Microphone Cable – 15’, fifteen foot microphone extension cable (yellow) (eight required):
 - 1. ProCo AQ-15M4F0PLM; or
 - 2. Whirlwind MKQ15-WSR-YEL.
- F. Microphone Cable – 25’, twenty-five foot microphone extension cable (red) (twelve required):
 - 1. ProCo AQ-25M2F0PLM; or
 - 2. Whirlwind MKQ25-WSR-RED.
- G. Microphone Cable – 50’, fifty foot microphone extension cable (blue) (eight required):
 - 1. ProCo AQ-50M6F0PLM; or
 - 2. Whirlwind MKQ50-WSR-BLU.
- H. Loudspeaker Cable 10’, portable loudspeaker cables with speakON 4-conductor connectors on each end of a rubber/neoprene (SO) jacketed 14 AWG minimum two conductor cable, minimum length of ten feet (four required):

1. Hosa SKT-410; or
 2. Proco Sound S14NN-10; or
 3. Whirlwind SK510G12.
- I. Loudspeaker Cable 25', portable loudspeaker cables with speakON 4-conductor connectors on each end of a rubber/neoprene (SO) jacketed 14 AWG minimum two conductor cable, minimum length of twenty-five feet (four required):
1. Hosa SKT-425; or
 2. Proco Sound S14NN-25; or
 3. Whirlwind SK525G12.
- J. Loudspeaker Cable 50', portable loudspeaker cables with speakON 4-conductor connectors on each end of a rubber/neoprene (SO) jacketed 14 AWG minimum two conductor cable, minimum length of fifty feet (four required):
1. Hosa SKT-450; or
 2. Proco Sound S14NN-50; or
 3. Whirlwind SK520G12.
- K. Category 6, 4-pair shielded patch cable. (number ##' portable required)
1. By Division 27 "Telecommunications Requirements for Audio Video Systems" Contractor
- L. Rugged Category 6, 4-pair shielded patch cable, with male Category 6 Neutrik connector on one end, and other end to be terminated to a male Category 6 connector by Division 27 "Telecommunications Requirements for Audio Video Systems" Contractor. (number ##' portable required)
1. Neutrik NKE6S-*-WOC.

2.15 CABLE ADAPTERS – PORTABLE

- A. All unbalanced adapters requiring assembly shall be wired pin 2/tip "hot" and pin 3/ring tied to the shield. XLR adapters shall not have pin 1 connected to case ground.
- B. MP3 Adaptor – Stereo XLRM 3', 1/8" audio to dual XLRM, no transformer, 3' cable (number required):
1. Proco IY-3.

2.16 LECTERNS, CARTS, AND OTHER FURNITURE

- A. Gooseneck – LED – Desk, portable, counter mounted LED lamp (with weighted base), with dimmer and power supply:
1. Littlite L-12-LED (12") with optional CWB weighted-base accessory (one required for each little theater); or
 2. Approved equal.

2.17 PORTABLE ACCESSORIES

- A. Stereo Audio Headphones, 75-ohms impedance minimum each receiver, noise-isolating, coiled cord, and 1/4-inch stereo phone plug (quantity required - auditorium, quantity two required for each school):

1. AKG HSC-271; or
2. Audio-technica ATH-M40fs; or
3. Sennheiser HD25 SP II.

B. Cable ties (forty ties required):

1. Toleeto Fasteners International Cord Lox 307-C, 1"x7"; or
2. Hosa WTI-148G (pkg of 5); or
3. Rip-Tie EconoWrap Slip-on 1" wide.

2.18 STANDBY EQUIPMENT

A. The following equipment shall be on-hand at the time of system commissioning and system first-use for possible replacement of defective equipment or for field conditions noted. Maintain ownership of this standby equipment. However, if any item of this standby equipment is used to replace defective equipment, the installed item of standby equipment becomes Owner's property. Assume ownership of the defective equipment:

1. Power Amplifier (one of each type required).
2. Backup software for programmable devices.
3. Laptop computer for all programmable devices.

B. Allowances for overnight shipping of critical components shall be included and utilized if component is required for Owner's initial operation or first-use.

PART 3 - EXECUTION

3.1 COMMON REQUIREMENTS

A. Refer to Division 27 Section "Audio Video Systems" for common requirements.

3.2 LABELING

A. Refer to Division 27 Section "Audio Video Systems" for labeling requirements.

B. Label the rear of loudspeakers in cluster with stencils spray paint of opposing color to match the labels shown on the technical system drawings. These labels should be visible only from the back side of the cluster (for service technicians).

END OF SECTION 274116

PLATTE CITY HIGH SCHOOL - AUDITORIUM AUDIO UPGRADES

APPENDIX A PROJECT PHASE REQUIREMENTS

DATE: THURSDAY, JANUARY 2, 2020

SUMMARY

Henderson Engineers has been contracted to perform analysis, evaluation, and recommendations regarding the Audio and Video systems within the Wilson Center for the Performing Arts. This report serves to set forth a “phased” upgrade recommendation based upon the results of the study.

Verify exact models and configuration in accompanying 27000 series specification and TA series design documents.

Provide response for Phase 2. Phase 1 is complete and phase 3 shall be issued at a later date.

1. PHASE 1 (COMPLETED SUMMER 2019)

- A. Mixing Console
 - 1. Replace existing mixing console with Yamaha QL5; with
 - a) Yamaha LA1L Gooseneck Console Lamp
- B. Digital Signal Processing
 - 1. Replace existing Digital Signal Processing with:
 - a) QSC QSYS Core 510 digital signal processor; and
 - b) QSC Dante Card CDN-64
- C. Front fill loudspeakers and amplification
 - 1. Replace existing Front Fill loudspeakers with:
 - a) Innovox HLA-Stage Lip loudspeakers
 - 2. Replace existing amplification for use with the Front Fill loudspeakers with:
 - a) QSC amplification
- D. Control System Processor/Video Router/Signal Transport
 - 1. Provide Crestron DMPS3-4K-150-C Digital Media Presentation Center
 - 2. Provide Crestron DM-TX-200-C-2G-B-T Wall Mount Video input to Proscenium wall (stage video input)
 - 3. Provide HDMI cable as indicated on signal flow drawing (booth input)
 - 4. Provide Crestron DM-RMC-4K-100-C-1G-B-T at projector location (projector signal/control transport output)
- E. Wireless Production Intercom
 - 1. Provide ClearCom/HME CZ115513 Wireless Production Intercom system
- F. Digital Audio Transports

Reference “High School Performing Arts Audio-Video Systems Minimum Capabilities and Recommended Solution” document for additional information and requirements.

 - 1. Provide Audio LAN Network Switch (Dante)
 - 2. Provide Audio LAN Network Switch (QLAN)
 - 3. Provide Audio LAN Network Switch (Control)
 - 4. Provide patch panel for all Category connections

- B. Assistive Listening System
 - 1. Provide Listen Technologies LT-800-072-01 Transmitter; with
 - a) LA-122 Antenna (and cabling per manufacturer's recommendation) Remotely mounted with line of site to majority of auditorium seating.
 - 2. Provide Listen Technologies LR-4200-072 Intelligent DSP RF Receiver (qty as required per ADA regulations – based on venue seating capacity); with
 - a) LA-401 Universal Ear Speaker (qty: 1 per receiver); and
 - b) LA-166 Neck loop (quantity per ADA requirements); and
 - c) LA-381 Intelligent 12-Unit Charging Tray (qty: 1); and
 - d) LA-320 Configurable Carrying Case (quantity as necessary to store all provided receivers).
- C. Check mic/line wiring
 - 1. Verify existing wiring and repair/replace as necessary
- D. Miscellaneous
 - 1. Provide "Tie Panel" in control booth. Populate and install as detailed on TA Sheet
- E. Portable
 - 1. Provide Yamaha RIO-1608-D (qty:1) installed in Gator Cases GRR-4PL-US

PHASE 2

Main Loudspeaker System - Left/Right/Mono loudspeaker configuration providing uniform full range audio coverage to most of the seating area. Specific loudspeaker model, configurations, and quantities to be confirmed. Amplifier selection based on loudspeaker design. Coordinate loudspeaker placement and orientation with Consultant.

- A. Replace existing loudspeaker system with Matrixed L/R-Mono line array system comprised of:
 - 1. Center Array: ElectroVoice EVA series; standard configuration (4) enclosures
 - 2. Left/Right Clusters: ElectroVoice EVA series; standard configuration (5) enclosures
 - 3. Subwoofer: Danley Sound Labs TH-118; standard configuration (2) enclosures suspended immediately upstage of the Center Array
 - 4. Front Fill Loudspeakers: Innovox HLA Stage Lip series; standard configuration (4) enclosures
 - 5. Booth Monitoring: ElectroVoice EVU series; standard configuration (3) enclosures
 - 6. Amplification: QSC CXD-Q Series
 - a) Select amplifiers to provide full peak amplification for each loudspeaker circuit per loudspeaker specifications.
 - b) Loudspeaker circuits shall not be designed to be below 4Ω nominal impedance.

PHASE 3 (FUTURE BID PACKAGE)

- A. Wireless Microphones
 - 1. Supplement existing wireless microphone systems with 12 additional channels and associated antenna distribution.
 - 2. Shure ULXD – (12 channels); with,
 - a) ULXD1 bodypack transmitter (qty: 12)
 - (1) Avlex HSP-50 Hair/Wig microphone with appropriate wireless bodypack adaptor (1 per transmitter plus 10% spare) **unless specified otherwise**
 - b) ULXD2/B58 handheld transmitter (qty: 2)
 - c) RF Venue Distro4 Antenna Distribution System
 - d) RF Venue Diversity Fin remote antenna
 - (1) RG-58 coax cable to remote antenna location
 - 3. Shure Wireless Workbench System Control Software

B. Wired Production Intercom

1. Add ClearCom Party Line production intercom

- a) Clearcom MS-702 mounted in the control booth location for use by stage manager/technical director
- b) Clearcom RS-701 single channel belt pack (qty: 8); with
(1) 15' XLR microphone cable for each belt pack
- c) Clearcom CC-300 headset (qty: 9)
- d) KB-701 Wall Mount Stations (qty. per venue requirements)
- e) Shure 514B Announce Microphone (in facilities requiring wall mount stations in back of house locations such as dressing room).

C. Miscellaneous Microphones, cables, etc.