

**City of Spartanburg**  
**Procurement and Property Division**  
**Post Office Drawer 5107, SC 29304-1749**  
**Phone (864) 596-2049 - Fax (864) 596-2365**

**Legal Notice**  
**Request for Proposal for**  
**Removal and Replacement of NEW Lights at the Kennedy Street Garage**

---

**April 25, 2018**

---

**NOTICE IS HEREBY GIVEN** – The City of Spartanburg is seeking proposal from vendors to provide construction services for Removal and Replacement of NEW lights at the Kennedy Street Garage. All work to comply with the specifications developed by the city to provide quality workmanship.

**Proposal Number: 1718-05-15-01**

The City of Spartanburg, hereby, notifies all proposers that it will affirmatively ensure that all disadvantaged and women's business enterprises will be afforded full opportunity to submit proposals in response to this invitation and will not be discriminated against on the grounds of gender, race, color or national origin in consideration for an award.

The City of Spartanburg reserves the right to reject any or all proposals or to waive any informality in the qualifications process. Proposals may be held by the City of Spartanburg for a period not to exceed sixty (60) days from the date of the opening of Proposals for the purpose of reviewing the Proposals and investigating the qualifications of prospective parties, prior to awarding of the Contract. The vendor that is awarded the proposal will be required to obtain a City of Spartanburg Business License and all the required Building Permits.

Calls shall be sent to Tony McAbee, Facilities Manager at 864-809-9085. Pre-Bid meeting will be held at the Kennedy Street Garage (TOP LEVEL) 160 E Kennedy St on Tuesday May 8, 2018 10:00 AM.

Email: [tmcabee@cityofspartanburg.org](mailto:tmcabee@cityofspartanburg.org).

Complete proposal package also available at [www.cityofspartanburg.org](http://www.cityofspartanburg.org) by following the links for Invitations for Bids.

Sealed Proposals shall be submitted to Carl Wright, Procurement and Property Manager on or before Tuesday May 15, 2018 no later than 3 PM, City Hall, 145 West Broad Street at which time they will be publicly opened and read aloud in the Training Room, same location.

Proposals can be hand delivered or mailed to the following address:

City of Spartanburg  
P.O. Box 5107  
145 W. Broad Street  
Spartanburg, SC. 29304

Attn: Procurement and Property Division

For further information and complete Proposal Package, please contact the Procurement and Property office at (864) 596-2049. Complete proposal package also available at [www.cityofspartanburg.org](http://www.cityofspartanburg.org) by following the links for Invitations for bids. The following Proposal Number Must be placed on the outer envelope in order for the bid to be Stamped in as accepted on time:

**Proposal No: 1718-05-15-01**

## **Submission of Questions and Qualifications Statement**

Submit two (2) complete copies of the firm's Proposal Statement. Submittals received by facsimile machine or other electronic transmittal will not be considered. Submittals are to be in sealed envelopes or boxes marked with the caption "Proposal Statement for Removal and Replacement of New Lights at the Kennedy Street Garage" and must be submitted to the attention of Mr. Carl Wright, Procurement and Property Manager, City of Spartanburg, P.O. Box 5107, Spartanburg, South Carolina 29304-1749, by 3:00PM, May 15, 2018. If using courier service, submittals should be sent attention Mr. Carl Wright, Procurement and Property Manager, City of Spartanburg, 145 West Broad Street, Spartanburg, South Carolina 29306.

Proposal Number MUST be placed on the outer envelope in order for the bid to be stamped in as accepted on time:

Technical questions regarding the scope of services should be directed to Tony McAbee, Facility Maintenance Manager, (864) 596-2107 or by email at [tmcabee@cityofspartanburg.org](mailto:tmcabee@cityofspartanburg.org) Questions regarding the RFQ process should be directed to Mr. Carl Wright, Procurement and Property Manager at (864) 596-2790 or [cwright@cityofspartanburg.org](mailto:cwright@cityofspartanburg.org)

### **Affirmative Action**

The contractor shall take affirmative action in complying with all state and federal requirements concerning fair employment and the treatment of all employees without regard to, or discrimination by reason of race, color, religion, sex, national origin or physical handicap.

## **CONTRACTOR INSURANCE REQUIREMENTS**

Contractor shall provide, pay for and maintain in full force and effect, all insurance outlined herein with limits of liability not less than the limits of liability shown covering Contractor's activities, those of any subcontractors or anyone directly or employed by any of them, or by anyone for whose acts any of them might be liable.

### **Insurer Qualifications**

All insurance should be provided through insurance companies authorized to do business in South Carolina with an A M Best's Rating of no less than A and shall be approved by and acceptable to Owner.

### **Certificates of Insurance**

Within **5 (five) days** of execution of Contract but **PRIOR** to commencing Work, Contractor's insurer shall provide to Owner a Certificate of Insurance issued by an authorized representative of its insurer certifying that the insurance as required in this Exhibit is in full force and effect. Certificates should be sent via fax or mail to the following:

Risk Coordinator  
City of Spartanburg  
P. O. Box 1749  
Spartanburg, SC 29304  
Fax: (864)596-2262  
Email: kbooker@cityofspartanburg.org

The original of the Certificate is to be sent as well. The Certificate shall include a statement that the policies will not be canceled or non-renewed without 30 days advance written notice to Owner.

### **Primary Insurance**

All insurance coverage required of the Contractor shall be primary over any insurance or self insurance carried by City of Spartanburg.

### **Duration of Coverage**

All required insurance coverage shall be maintained without interruption during the entire term of the Contract plus an additional 3 years for Products and Completed Operations Coverage following final acceptance of the Work by Owner.

### **Subcontractor's Insurance**

The Contractor shall require any Subcontractor to purchase and maintain insurance of same types and limits required herein.

### **Waiver of Subrogation**

The Contractor shall require all policies of insurance as required herein to be endorsed to provide that the insurance company shall waive all of its right of recovery or subrogation against Owner. The Contractor shall require similar waivers from any Sub-contractors.

### **Additional Insured**

The Contractor's insurance policies as required herein with the exception of Workers Compensation shall be endorsed to name Owner as an additional insured.

### **Insurance Coverage and Limits**

**Workers' Compensation:** The Contractor shall provide and maintain Workers Compensation insurance in each jurisdiction in which the Work is located.

Limits:

Coverage A – State Statutory Benefits	
Coverage B – Employers Liability	\$1,000,000

Specific Coverage:

- United States Longshoremen and Harbor Workers Act
- Coverage endorsement must be provided if any work is to be performed on or around navigable water.

**Automobile Liability:** Contractor shall provide and maintain Business Auto Liability insurance covering bodily injury and/or property damage liability arising out of the use of any auto (including owned, hired, and non-owned autos).

Limits:

Combined Single Limit Each Accident: \$1,000,000

**Commercial General Liability:** Contractor shall provide and maintain in full force and effect Commercial General Liability Insurance covering all operations by or on behalf of Contractor on an occurrence basis against claims for bodily injury, personal in-jury, and/or property damage (including loss of use).

Limits:

Each Occurrence	\$1,000,000
General Aggregate	\$2,000,000
Products/Completed Operations	\$2,000,000

Specific Coverage:

- Occurrence Form
- Blanket Contractual Liability
- Underground Explosion and Collapse

**Umbrella/Excess Liability:** Contractor shall provide and maintain Umbrella/Excess Liability Insurance on an occurrence basis with coverage as broad as underlying policies.

Limits:

Each occurrence:	\$2,000,000
Annual Aggregate:	\$2,000,000

Specific Coverage:

- Blanket Contractual Liability
- Follow Form Primary

**Other Insurance:** Any other insurance as specified by Owner in the Contract Documents.

**Changes:** Exceptions to specified insurance requirements shall be submitted at time of any bid.



**Removal and Replacement of NEW lights at the Kennedy Street Garage**

**City of Spartanburg**  
**P.O. Box 5107**  
145 W. Broad Street  
Spartanburg, SC. 29304  
Email:  
cwright@cityofspartanburg.org

Proposer has examined this Request for Proposal, the Advertisement for this Request for Proposal, and the following Addenda (receipt of which is hereby acknowledged):

Company Name: \_\_\_\_\_

By: \_\_\_\_\_ (Signature)

\_\_\_\_\_ (Printed Name)

Title: \_\_\_\_\_

Date: \_\_\_\_\_

Address: \_\_\_\_\_ Email: \_\_\_\_\_

City: \_\_\_\_\_ State: \_\_\_\_\_ Zip: \_\_\_\_\_

Telephone: \_\_\_\_\_ Fax: \_\_\_\_\_

Addenda Number: \_\_\_\_\_ Date: \_\_\_\_\_

Addenda Number: \_\_\_\_\_ Date: \_\_\_\_\_

**BASE PRICE for Total Cost Removal** \$ \_\_\_\_\_  
**and Replacement of NEW lights for the Kennedy Street Garage**

**Please complete the provided proposal sheet which outlines the cost.**

By: \_\_\_\_\_ Title: \_\_\_\_\_

Signature: \_\_\_\_\_ Date: \_\_\_\_\_

Address: \_\_\_\_\_

**Telephone / \_\_\_\_\_ Email: \_\_\_\_\_**

\_\_\_\_\_ submits here with our proposal in response to the bid request

(Company Name)

number shown above in compliance with the description(s) and specifications (s) for the following:

Exhibit A

**CONSTRUCTION SERVICES FOR  
INSTALLATION OF LED LIGHTING  
AT THE KENNEDY STREET PARKING GARAGE**

**SCOPE OF WORK**

**General**

The purpose of this work is to provide construction services for the installation of a new LED lights and components. Work will include removal of the existing lighting components and installation of new Owner provided lights. It shall include, but not limited to, replacement of existing 175 watt HID lights with new Hubbell GSL Series Garage/Surface/LED.

**Construction Phase**

All work shall be warranted for a period not less than one (1) year from the date of acceptance.

1. Demolition of all existing component that are not part of the requirements for replacement.
2. Contractor shall utilize the exiting conduits and boxes. All wiring and equipment shall comply with manufacturers recommendation.
3. The contractor is required to install conduit from existing box to the new light location.
4. Contractor shall maintain a safe and clean site.
5. Contractor shall be responsible for securing and barricading the construction zone to limit pedestrian and vehicular access.
6. Contractor is responsible for all License, Fees and Permits for the City of Spartanburg.
7. Contractor shall be responsible for insurance requirement per the Contract Documents.
8. Contractor shall be responsible for maintaining a clean site and shall leave the area of work clean at the end of the day.
9. If contractor would like to perform this work on off hours. The contractor will coordinate with city staff prior to work. Any work perform on off hour shall be a regular cost to the City of Spartanburg.
10. The Kennedy Street Parking Garage has 23 pole lights on the top level and approximately 273 pendant light between double tees. Contractor shall provide a cost for 296 lights, but will break-down into unit price per fixture for any work done in a Change Order.

See Attachment # 1  
Detailed drawing for Stem application



Install the following to the existing box and 1/2" x 12" stem –

- A. 1/2" Rigid Type C
- B. 1/2" x 4" Rigid Nipple
- C. 3/4" x 1/2" Rigid Reducing Bushing
- D. Hubbell GSL Series LED Light
- E. Set timer on each light with remote control

Submit all questions in writing to: No questions will be answered verbally.

Tony McAbee  
Building Maintenance Manager  
City of Spartanburg  
[tmcabee@cityofspartanburg.org](mailto:tmcabee@cityofspartanburg.org)

<b>GSL SERIES</b> GARAGE/SURFACE/LED	Cat.#	
	Job	
Approvals		

**SPECIFICATIONS**

**Intended Use:**

Ceiling applications from eight to fifteen feet for box or pendant mount. Applications include parking garage, walkway or building canopies, corridors, tunnels, large stairwells and other interior applications with ambient up to 40°C. Two lumen packages and optical distributions are available making the GSL Series luminaire both versatile and functional.

**Construction:**

- Vertically finned cast aluminum housing for maximum heat dissipation ensuring long component life and luminaire performance
- IP66 luminaire rating
- Durable gray powder coat paint finish
- Two 1/2" threaded hubs for accessories

**Optics/Electrical**

**LED:**

Two lighting distributions are included: Type V square (installed), Type II rectangle (in carton). Each LED has individual optical grade PMMA acrylic lens to ensure repeatable photometrics and enhanced performance. The design's overlapping redundant patterns of light ensure consistent light level uniformity regardless of the unit being in a dimmed mode or number of LEDs illuminated

- CCT: 4000K (70 CRI)
- Lumen packages ranging from 6,000 – 8,400 with 15 or 21 LEDs
- Wattage: 53 or 75
- Lumens per watt: 111-113
- 15KA surge protection included standard

**Drivers:**

- Single constant current, 1050mA, IP66 and RoHS compliant
- 120V-277V, 50/60hz, > 90% Power Factor, < 20% THD
- 0-10V dimming (dimming leads pulled and staged for easy sensor installation)

**Controls:**

- Programmable motion sensor option available. Stand alone photocell only available as an accessory to be ordered separately and field installed

**Installation:**

Mounts directly to 4" junction boxes or 3/4" pendant stems, making the fixture adaptable for multiple applications. Each mounting can be accomplished while maintaining a watertight seal.

- Designed for up to 40° C ambient temperatures
- Minimum operating temperature is -30° C/-22° F
- Hinged mounting plate for easy single person installation

**Listings:**

Listed to UL 1598 for use in wet locations, 40° C ambient environments; IP66

- DesignLights Consortium (DLC) Qualified, consult DLC website for more details: <http://www.designlights.org/QPL>

**Warranty:**

Five year limited warranty (for more information visit: <http://www.hubbelloutdoor.com/resources/warranty/>)

**PRODUCT IMAGE(S)**

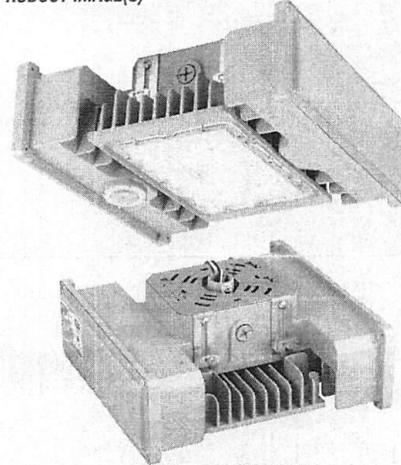

Top mounting bracket

**DIMENSIONS**

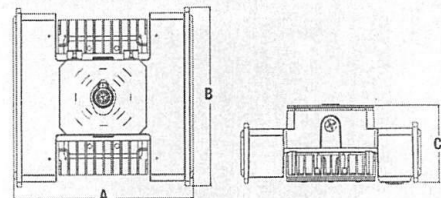

A	B	C	Weight:
12.5" (317.5 mm)	12.01" (304 mm)	5.21" (132 mm)	13.8 lbs 6.25 kg

**CERTIFICATIONS/LISTINGS**



**ORDERING INFORMATION**

ORDERING EXAMPLE: GSL-15L

GSL	-		-	
SERIES	NUMBER OF LEDS	OPTION		
GSL garage/surface LED	15L 15 LEDs 21L 21 LEDs	SCP <sup>1</sup> Programmable motion control, with built in photocell, factory default is 10% light output		

<sup>1</sup> Must order minimum of one SCP-REMOTE to program dimming settings. 0-10V fully adjustable dimming with automatic daylight calibration and off-peak time delay settings. 120V-277V only

**ACCESSORIES/REPLACEMENT PARTS - Order separately**

CATALOG NUMBER	DESCRIPTION
GSL-SPC	Vandal shield, polycarbonate
GSL-CS	Comfort shield, acrylic, improved uniformity, 8% lumen reduction
93048453	Programmable motion sensor (High/low or on/off capability, user programmable low settings) Must also order lens 95005520 and at least (1) SCP-REMOTE per project to program
95005520	Motion sensor lens (wide lens, 4.8 ft. diameter, 16ft. maximum mounting height)
PTA-1	120V button photocell with 1/2" thread
PTA-8	120V - 277V button photocell with 1/2" thread
SCP-REMOTE	Infrared IR remote control to program motion sensor (Minimum 1 required per project)
GSL-MTG-PL	Hinged mounting plate
GSL-LENS-M	15 and 21 LED lens for symmetrical Type V
GSL-LENS-R	15 and 21 LED lens for asymmetrical Type II rectangular
GSL-Protector	15 KA surge protector



Hubbell Outdoor Lighting • 701 Millennium Boulevard • Greenville, SC 29607 • Phone: 864-678-1000  
 Due to our continued efforts to improve our products, product specifications are subject to change without notice.

© 2015 HUBBELL OUTDOOR LIGHTING, All Rights Reserved • For more information visit our website: [www.hubbelloutdoor.com](http://www.hubbelloutdoor.com) • Printed in USA

GSL-SPEC 5/17



## Installation of LED Pole lights to the existing pole on the Top Deck

<h1>VIPER S SERIES</h1> <p>SMALL VIPER LUMINAIRE</p>	Cat.#	
	Job	
		Approvals

### SPECIFICATIONS

#### Intended Use:

The Beacon Viper luminaire is available with a wide choice of different LED Wattage configurations and optical distributions designed to replace HID lighting up to 400W MH or HPS.

#### Construction:

- Manufactured with die cast aluminum.
- Coated with a polyester finish that meets ASTM B117 corrosion test requirements and ASTM D522 cracking and loss of adhesion test requirements.
- External hardware is corrosion resistant.
- One piece optical cartridge system consisting of an LED engine, LED lamps, optics, gasket and stainless steel bezel.
- Cartridge is held together with internal brass standoffs soldered to the board so that it can be field replaced as a one piece optical system.
- Two-piece silicone and micro-cellular polyurethane foam gasket ensures a weather-proof seal around each individual LED.

#### Electrical:

- 100V through 277V, 50 Hz to 60 Hz (UNV), or 347V or 480V input.
- Power factor is  $\geq 0.90$  at full load.
- Dimming drivers are standard, but must contact factory to request wiring leads for purpose of external dimming controls.
- Component-to-component wiring within the luminaire may carry no more than 80% of rated load and is certified by UL for use at 600VAC at 90°C or higher.
- Plug disconnects are certified by UL for use at 600 VAC, 13A or higher. 13A rating applies to primary (AC) side only.
- Fixture electrical compartment shall contain all LED driver components and shall be provided with a push-button terminal block for AC power connections.
- The housing is designed for an optional twist lock photo control receptacle.
- Ambient operating temperature -40°C to 40°C
- Surge protection - 20KA.
- Optional 7-pin ANSI C136.41-2013 twist-lock photo control receptacle available. Compatible with ANSI C136.41 external wireless control devices.
- Lifeshield™ Circuit - protects luminaire from excessive temperature. The device shall activate at a specific, factory-preset temperature, and progressively reduce power over a finite temperature range. Operation shall be smooth and undetectable to the eye. Thermal circuit is designed to "fail on", allowing the luminaire to revert to full power in the event of an interruption of its power supply, or faulty wiring connection to the drivers. The device shall be able to co-exist with other 0-10V control devices (occupancy sensors, external dimmers, etc.).

#### Controls/Options:

- Available with an optional passive infrared (PIR) motion sensor capable of detecting motion 360° around the luminaire. When no motion is detected for the specified time, the Motion Response system reduces the wattage to factory preset level, reducing the light level accordingly. When motion is detected by the PIR sensor, the luminaire returns to full wattage and full light output. Please contact Beacon Products if project requirements vary from standard configuration.
- Available with Energen for optional set dimming, timed dimming with simple delay, or timed dimming based on time of night (see [www.beaconproducts.com/products/energen/](http://www.beaconproducts.com/products/energen/)).
- In addition, Viper can be specified with SiteSync™ wireless control system for reduction in energy and maintenance cost while optimizing light quality 24/7. See ordering information or visit [www.hubbelling.com/sitesync/](http://www.hubbelling.com/sitesync/) for more details.

#### Installation:

- Mounting options for horizontal arm, vertical tenon or traditional arm mounting available. Mounting hardware included.

#### Finish:

- IFS polyester powder-coat electro-statically applied and thermocured.
- IFS finish consists of a five stage pretreatment regimen with a polymer primer sealer and top coated with a thermoset super TGIC polyester powder coat finish.
- The finish meets the AAMA 605.2 performance specification which includes passing a 3000 hour salt spray test for corrosion resistance and resists cracking or loss of adhesion per ASTM D522 and resists surface impacts of up to 160 inch-pounds.

#### Listings:

- DesignLights Consortium (DLC) qualified, consult DLC website for more details: <http://www.designlights.org/QPL>
- Certified to UL 1598 and CSA C22.2 No.250.0
- IDA approved
- This product is approved by the Florida Fish and Wildlife Conservation Commission. Separate spec available at: <http://www.beaconproducts.com/products/vipersmall>

#### Warranty:

Five year limited warranty for more information visit: [www.hubbelling.com/resources/warranty](http://www.hubbelling.com/resources/warranty)

### PRODUCT IMAGE(S)



### DIMENSIONS

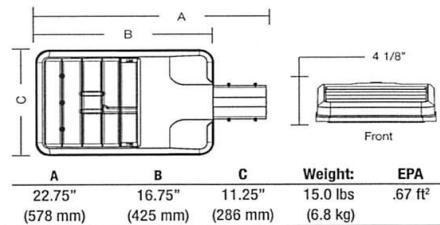

### MOUNTING OPTIONS

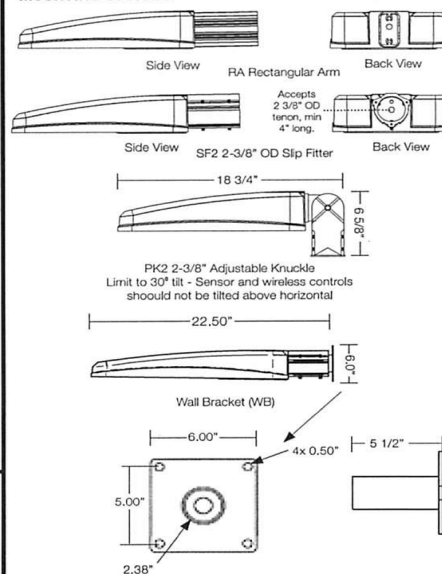

### CERTIFICATIONS/LISTINGS



Beacon Products • 2041 58th Avenue Circle East Bradenton, FL 34203 • Phone: 800-345-4928  
 Due to our continued efforts to improve our products, product specifications are subject to change without notice.  
 © 2015 BEACON PRODUCTS, All Rights Reserved • For more information visit our website: [www.beaconproducts.com](http://www.beaconproducts.com) • Printed in USA MARCH 29, 2018 1:45 PM





# Exhibit F

## DRUG FREE WORKPLACE ACT STATEMENT

The undersigned hereby certifies on behalf of the company listed below that it is in full compliance with the requirements set forth in Title 44, Code of Laws of South Carolina, 1976, Chapter 107, Paragraph 47 and the Drug-Free Workplace Act of 1988 (Public Law 100-690, title V, Sec. 5153, as amended by Public Law 105-85, Div. A, Title VIII, Sec. 809, as codified at 41 U.S.C. § 702) and Department of Commerce implementing regulations published at 15 CFR Part 29, "Government-wide Requirements for Drug-Free Workplace (Financial Assistance)" (published in the Federal Register on November 23, 2003, 68 FR 66534).

\_\_\_\_\_

(Name of Corporation or Entity)

By: \_\_\_\_\_ (Signature)

\_\_\_\_\_ (Print name)

Title: \_\_\_\_\_

Date: \_\_\_\_\_

## EXISTENCE OF SUBCONTRACTORS FORM

Will you subcontract any part of this Work? Yes \_\_\_\_ No \_\_\_\_ If so, please list the names, addresses and licenses of the subcontractors to be used for the portions of the work listed below.

1. SUBCONTRACTOR NAME \_\_\_\_\_

SUBCONTRACTOR DUTY \_\_\_\_\_

TYPE OF LICENSE: \_\_\_\_\_

(Attach copy of subcontractor license)

2. SUBCONTRACTOR NAME \_\_\_\_\_

SUBCONTRACTOR DUTY \_\_\_\_\_

TYPE OF LICENSE: \_\_\_\_\_

(Attach copy of subcontractor license)

3. SUBCONTRACTOR NAME \_\_\_\_\_

SUBCONTRACTOR DUTY \_\_\_\_\_

TYPE OF LICENSE: \_\_\_\_\_

(Attach copy of subcontractor license)

4. SUBCONTRACTOR NAME \_\_\_\_\_

SUBCONTRACTOR DUTY \_\_\_\_\_

TYPE OF LICENSE: \_\_\_\_\_

(Attach copy of subcontractor license)

5. SUBCONTRACTOR NAME \_\_\_\_\_

SUBCONTRACTOR DUTY \_\_\_\_\_

TYPE OF LICENSE: \_\_\_\_\_

(Attach copy of subcontractor license)

### EXPERIENCE/ REFERENCES

List five jobs, similar in size, completed by Proposer. List dollar amount, brief description reference name and phone number for each job.

a. Name of Project: \_\_\_\_\_ Owner/Engineer:  
\_\_\_\_\_ Telephone No.:  
\_\_\_\_\_ Address:  
\_\_\_\_\_ Date Started: \_\_\_\_\_ Date Completed:  
\_\_\_\_\_ Value of Contract: \_\_\_\_\_ Project Description:  
\_\_\_\_\_

b. Name of Project: \_\_\_\_\_ Owner/Engineer:  
\_\_\_\_\_ Telephone No.:  
\_\_\_\_\_ Address:  
\_\_\_\_\_ Date Started: \_\_\_\_\_ Date Completed:  
\_\_\_\_\_ Value of Contract: \_\_\_\_\_ Project Description:  
\_\_\_\_\_

c. Name of Project: \_\_\_\_\_ Owner/Engineer:  
\_\_\_\_\_ Telephone No.:  
\_\_\_\_\_ Address:  
\_\_\_\_\_ Date Started: \_\_\_\_\_ Date Completed:  
\_\_\_\_\_ Value of Contract: \_\_\_\_\_ Project Description:  
\_\_\_\_\_

d. Name of Project: \_\_\_\_\_ Owner/Engineer:  
\_\_\_\_\_ Telephone No.:  
\_\_\_\_\_ Address:  
\_\_\_\_\_ Date Started: \_\_\_\_\_ Date Completed:  
\_\_\_\_\_ Value of Contract: \_\_\_\_\_ Project Description:  
\_\_\_\_\_

e. Name of Project: \_\_\_\_\_ Owner/Engineer:  
\_\_\_\_\_ Telephone No.:  
\_\_\_\_\_ Address:  
\_\_\_\_\_ Date Started: \_\_\_\_\_ Date Completed:  
\_\_\_\_\_ Value of Contract: \_\_\_\_\_ Project Description:  
\_\_\_\_\_

**Exhibits J**  
**AFFIDAVIT OF NON-COLLUSION**

I state that I am \_\_\_\_\_ (title) of \_\_\_\_\_ (name of firm) and that I am authorized to make this affidavit on behalf of my firm, and its owners, directors, and officers. I am the person responsible in my firm for the price(s) and the amount of this Offer.

I state that:

- (1) The price(s) and amount of this Offer have been arrived at **independently and** without consultation, communication or agreement with any other Proposer or potential Proposer.
- (2) That neither the price(s) nor the amount of this Offer, and neither the approximate price(s) nor approximate amount of this Offer, have been disclosed to any other firm or person who is a Proposer or potential Proposer, and they will not be disclosed before Solicitation opening.
- (3) No attempt has been made or will be made to induce any firm or person to refrain from bidding on this contract, or to submit an Offer higher than this Offer, or to submit any intentionally high or noncompetitive Offer or other form of complementary Offer.
- (4) The Offer of my firm is made in good faith and not pursuant to any agreement or discussion with, or inducement from, any firm or person to submit a complementary or other noncompetitive Offer.
- (5) \_\_\_\_\_ (name of firm), its affiliates, subsidiaries, officers, directors and employees are not currently under investigation by any governmental agency and have not in the last four years been convicted of or found liable for any act prohibited by State or Federal law in any jurisdiction, involving conspiracy or collusion with respect to bidding on any public contract, except as described in the attached appendix.

I state that \_\_\_\_\_ (name of firm) understands and acknowledges that the above representations are material and important, and will be relied on **by the City of Spartanburg** in awarding the contract(s) for which this Offer is submitted. I understand and my firm understands that any misstatement in this affidavit is and shall be treated as fraudulent concealment from the **City of Spartanburg** of the true facts relating to the submission of Offers for this contract.

\_\_\_\_\_

(Authorized Signature)

\_\_\_\_\_

(Name of Company/Position)

Sworn to and subscribed before me this \_\_\_\_\_ day of \_\_\_\_\_, 20\_\_\_\_.

\_\_\_\_\_

Notary

My Commission Expires: \_\_\_\_\_

**GOOD FAITH DOCUMENTATION MUST ACCOMPANY THE BID DOCUMENT**

City of Spartanburg, hereby, notifies all proposers that it will affirmatively ensure that all disadvantaged and women's business enterprises will be afforded full opportunity to submit bids in response to this invitation and will not be discriminated against on the grounds of gender, race, color, or national origin in consideration for an award. Each proposer shall attest that they engaged in good faith efforts in an endeavor to achieve the City's M/WBE goal of 10%.

Any questions or any assistance please contact Mrs. Natasha Pitts.

Contact Information

Phone 864-596-3449

Email [npitts@cityofspartanburg.org](mailto:npitts@cityofspartanburg.org)

**INTENT TO PERFORM CONTRACT WITH OWN WORKFORCE**

I HERBY CERTIFY THAT IT IS OUR INTENT TO PERFORM 100% OF THE WORK REQUIRED FOR THE ABOVE PROJECT. IN MAKING THIS CERTIFICATION, THE BIDDER STATES THAT THE BIDDER DOES NOT CUSTOMARILY SUBCONTRACT ELEMENTS OF THIS TYPE OF PROJECT, AND NORMALLY PERFORMS AND HAS THE CAPACITY TO PERFORM AND WILL PERFORM **ALL ELEMENTS OF THE WORK** PROJECT WITH HIS/HER OWN CURRENT WORK FORCES; AND IF THE BIDDER DOES NOT PERFORM 100% OF THE WORK REQUIRED, THE BIDDER WILL PROVIDE A LIST OF SUBCONTRACTORS

THE BIDDER AGREES TO PROVIDE ANY INFORMATION OR DOCUMENTATION TO THE CITY OF SPARTANBURG IN SUPPORT OF THE ABOVE STATEMENT.

THE UNDERSIGNED HEREBY CERTIFIES THAT HE OR SHE HAS READ THIS DOCUMENTATION AND IS AUTHORIZED TO BIND THE BIDDER TO THE COMMITMENTS HEREIN SET FORTH.

The listing of an MWBE shall constitute a representation by the bidder/responder to City of Spartanburg that such MWBE has been contacted and properly appraised of the upcoming City of Spartanburg project. Bidders/Responders are advised that the information contained herein is subject to verification by the Minority & Women Business Enterprise Program Coordinator and that submission of said information is an assertion of its accuracy. These documents are a part of this solicitation and contract. You are required to fill out this information.

I certify that the above information is true to the best of my knowledge:

Signature: \_\_\_\_\_

Title: \_\_\_\_\_

Date: \_\_\_\_\_

Subscribed and sworn to before me this \_\_\_\_\_ day of \_\_\_\_\_, 20\_\_.

Notary Signature \_\_\_\_\_

Notary Seal

**THIS DOCUMENT MUST BE PROVIDED WITH THE SUBMITTAL AND SIGNED BY THE PERSON SIGNING THE SUBMITTAL**



**MWBE Good Faith Effort Participation Commitment Contract**

This form should be filled out completely and *included in your bid document*. This form should also be accompanied by an executed Letter of Intent from each Sub-Contractor firm listed in this form. You may use additional sheets if necessary.

<b>BID NO:</b>	<b>DATE:</b>
<b>PROJECT NAME:</b>	<b>ADDRESS:</b>
<b>PRIME CONTRACTOR:</b>	<b>CITY:</b> _____ <b>STATE:</b> _____
<b>CONTACT PERSON:</b>	<b>EMAIL:</b>
<b>TELEPHONE: (     )     )</b>	<b>FAX: (     )     )</b>

**MWBE SUBCONTRACTORS**

COMPANY	MWBE CLASS	CITY, STATE	CONTACT	PHONE	TYPE OF WORK TO BE PERFORMED	SUBCONTRACT AMOUNT	% OF WORK
						\$	%
						\$	%
						\$	%
						\$	%
						\$	%
Total MWBE Participation						\$	
Total Contract Amount						\$	

**MWBE CLASSIFICATION**  
 MBE-B - African American    MBE-S - Asian American    MBE-H - Hispanic  
 American WBE - American Woman    MBE N/A - Native American

**NON-MWBE SUBCONTRACTORS**

COMPANY	MWBE CLASS	CITY, STATE	CONTACT	PHONE	TYPE OF WORK TO BE PERFORMED	SUBCONTRACT AMOUNT	% OF WORK
						\$	%
						\$	%
						\$	%
						\$	%
						\$	%
Total Non-MWBE Participation						\$	
Total Contract Amount						\$	

CERTIFICATION OF NON-SEGREGATED FACILITIES – YEAR 2018

We, (print company name: ) \_\_\_\_\_, certify to City of Spartanburg, South Carolina we do not and will not maintain or provide for our employees any segregated facilities at any of our establishments, and that we do not and will not permit our employees to perform their services at any locations, under our control, where segregated facilities are maintained. We understand and agree that a breach of this certification is a violation of the Equal Opportunity clause.

As used in this certification, the term “segregated facilities” means any waiting rooms, work areas, rest rooms, restaurants and other eating areas, time clocks, locker rooms and other storage or dressing areas, parking lots, drinking fountains, recreation or entertainment areas, transportation and housing facilities provided for employees which are **segregated by explicit directive or are in fact segregated on the basis of race, religion, color or national origin because of habit, local custom or otherwise.**

We further agree that --- except where we have obtained identical certifications from proposed Subcontractors for specific time periods --- we will obtain identical certifications from proposed Subcontractors prior to the award of Subcontracts exceeding which are not exempt from the provisions of the Equal Opportunity clause; that we will retain such certifications in our files; and that we will forward the following notice to such proposed Subcontractors (except where the proposed Subcontractors have submitted identical certifications for specific time periods). ***NOTE: Whoever knowingly and willfully makes any false, fictitious or fraudulent representation may be liable to criminal prosecution under 18 U.S.C. 1001.***

PLEASE COMPLETE BELOW AND INCLUDE THIS IN THE BID PACKAGE

Name of Company Representative: \_\_\_\_\_

Title: \_\_\_\_\_

Signature: \_\_\_\_\_

Date: \_\_\_\_\_