

City of
SHELBYVILLE
Tennessee

DATE: January 11, 2022

NOTICE TO BIDDERS

Notice is hereby given that the CITY OF SHELBYVILLE, TENNESSEE is advertising for sealed bids on:

**GYM AND POOL LOCKERS
FOR SHELBYVILLE RECREATION CENTER**

Bids will be accepted by the City of Shelbyville Purchasing Office, 201 N. Spring Street, Shelbyville, TN 37160 or may be mailed to P.O. Box 185, Shelbyville, TN 37162 **until 2:00 P.M. on Thursday, January 27, 2022** Any bids received after the scheduled closing time for receipt of bids will be returned to the bidder unopened.

The bids shall be opened and read aloud during a public meeting of the City Council appointed BID COMMITTEE on Thursday, January 27, 2022 at 2:00 P.M. at Shelbyville City Hall, Conference Room, 201 N. Spring Street, Shelbyville, TN. Award of the bid is scheduled to be on the agenda at the next City Council business meeting at the Shelbyville Recreation Center. (February 10, 2022)

GENERAL INFORMATION

It will be the sole responsibility of the Bidder to deliver personally or by mail the bid or bids to the City of Shelbyville Purchasing Office, 201 N. Spring Street, Shelbyville, TN 37160 on or before the closing hour and date announced for the receipt of the bids. **The envelope must be sealed and marked on the outside “Sealed Bid - Gym and Pool Lockers for Shelbyville Recreation Center”.**

The City is exempt from taxes imposed by State and/or Federal Government. Exemption certificate, if required, will be furnished by the successful bidder and will be completed by the City.

Each variance to these specifications must be specifically stated by the bidder in the bidding proposal. The City Council reserves the right to reject any or all proposals, to waive informalities and to accept all or any part of any proposal as described therein, as they deem necessary to be in the best interest of the City.

City of Shelbyville

Bidders guarantee that the prices quoted in the bid will remain firm from the date of the bid opening until the completion of delivery.

All proposals shall be made on forms furnished by the CITY. Supporting information shall be on the bidder's stationery.

All proposals must indicate the firm's name and address and be signed in ink by an officer or employee having authority to bind the company or firm.

The intent of these specifications is to insure delivery of a new complete unit for operation. Omission of any essential detail from these specifications does not relieve the supplier from furnishing such unit. All bids must be on new models. This provision excludes surplus, used or demonstrators.

The bidder, by executing a contract or bid proposal on the terms of the invitation to bid, warrants the product that is supplied to be buyer shall remain fully in accord with the specifications and to be of the highest quality. In the event the product, as supplied to the buyer, is found to be defective or does not conform to the specifications, the buyer reserves the right to cancel the order upon written notice to the supplier and return such product to the supplier at the supplier's expense.

Payment will commence or be made in full after delivery and acceptance of product. All documents, invoice, title and exemption certificate shall be presented to the City of Shelbyville Purchasing Office.

All Bidders must comply with A.D.A. guidelines if required.

All Bidders must be in compliance with Title VI, Civil Rights Act of 1964, which specifies that: No person in the United States shall, on the grounds of race, color or national origin, be excluded from participation in, be denied the benefits of, or be subjected to discrimination under a program or activity receiving federal financial assistance from the Department of Transportation or the U.S. Department of Justice.

The City of Shelbyville is subject to the Open Records Act, TCA 10-7-501, et. Seq. Bidders are advised that all documents submitted on behalf of this invitation to bid shall be open to the public for viewing and inspection.

The City of Shelbyville will fulfill Public Record Requests in compliance with Tennessee Open Records Act.

Failure on the part of the bidder to comply with all instructions herein may result in bid rejection.

BID FORM

TO: City of Shelbyville
201 N. Spring Street
Shelbyville, TN 37160

Date: _____

IN ACCORDANCE WITH YOUR INVITATION TO BID ON:

GYM AND POOL LOCKERS FOR SHELBYVILLE RECREATION CENTER

WE HEREBY SUBMIT THE FOLLOWING BID:

MINIMUM SPECIFICATIONS

MEETS

EXCEEDS

DOESN'T MEET

Total of 327 lockers for both
Gymnasium and Pool Locker Rooms -
see summary sheet attached

Specification sheets of original
lockers placed in facility when it
was built in 1995 are included in
this packet.

A diagram of the men's pool
locker area is included. Any
difference in the women's
pool locker area is noted.

A diagram of the women's gym
locker area is included. Any
difference in the men's gym
locker area is noted.

Bidders will be given the option
to bid both assembled and
unassembled.

MINIMUM SPECIFICATIONS

MEETS

EXCEEDS

DOESN'T MEET

Turnkey project to include all necessary materials and hardware necessary for local staff to install.

An install option is also included on the bid form.

Quality product with professional appearance required

Any reference to half lockers should be replaced with a full locker. No half lockers in bid submission.

Site survey highly recommended

Please schedule site visit with Mike Alsup, Parks and Recreation Director
931/684-9780

Delivery cost to be included in bid submission.

Clearly specify warranty.

PLEASE INCLUDE WITH BID SUBMISSION AVAILABLE COLORS.

Any reference to name brands in this Invitation for Bids or the attached specification sheets is for example only. An approved equal will be accepted. The purchaser reserves the right to determine whether a substitute offer is equivalent to and meets the standard of quality indicated by the brand name referenced, and the purchaser may require a bidder offering a substitute to supply additional descriptive material.

- Vendors are welcome to submit more than one bid if options are available.
- A current business license must be furnished upon request.
- Any questions may be directed to Parks & Recreation Director, Mike Alsup, at 931-684-9780 or Lori Saddler, Purchasing / IT Director, at 931-684-2691.

We hereby submit the following price(s) for your consideration:

\$ _____ total for assembled lockers as specifications attached.

OR

\$ _____ total for unassembled lockers as specifications attached.

INSTALL OPTION:

\$ _____ additional charge to install on-site.

Estimated delivery date: _____

Color options included in submission: _____ Yes _____ No

Signed: _____

Printed name: _____

Title: _____

Date: _____

Email: _____

Phone #: _____

Company Name and Address:

Bid quote good for _____ days.

Location	Part	Measurement	Total
Gym Locker Room	Lockers	12"X 15"X 72"	172
	Sloped Top	15"X 72"	34
	Sloped Top Corner	15"X 15"	12
	Sloped Top End	15"	10
	Finished End	15"X 72"	10
	Filler Piece	3"	5
	Pool Locker Room	Lockers	12"X 15"X 72"
Sloped Top		15"X 72"	32
Sloped Top Corner		15"X 15"	16
Sloped Top End		15"	15
Finished End		15"X 72"	15
Filler Piece		11"	1
Grand Totals		Lockers	12"X 15"X 72"
	Sloped Top	15"X 72"	66
	Sloped Top Corner	15"X 15"	28
	Sloped Top End	15"	25
	Finished End	15"X 72"	25
	Filler Piece	3"	5
	Filler Piece	11"	1

(888) 446-5797

Pool

NOTE: COLOR SELECTION AND NUMBERING SEQUENCE MUST BE INDICATED BEFORE THE ORDER CAN BE PUT INTO PRODUCTION.

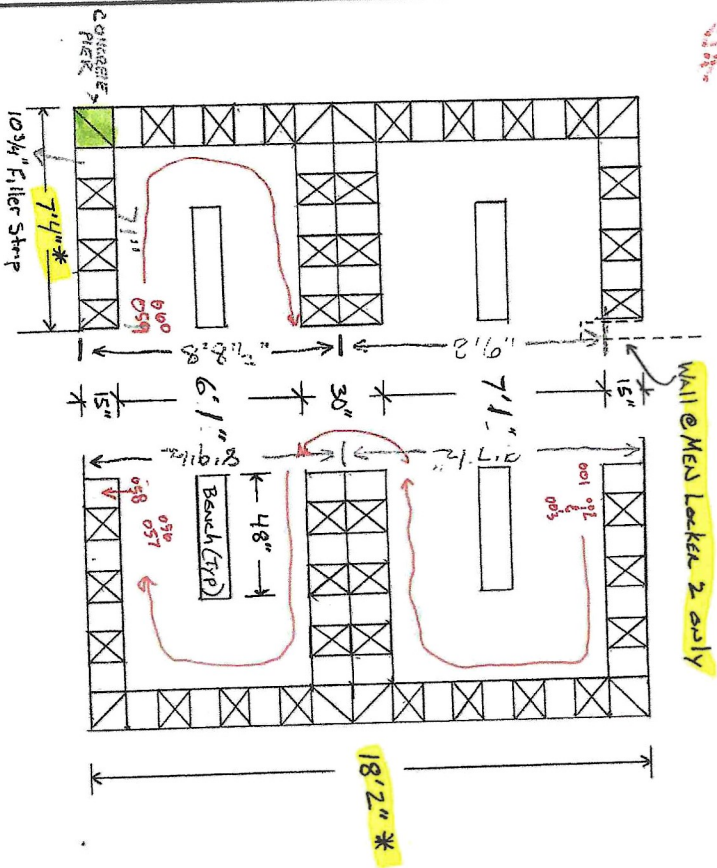

28 - SQUARE TILE
 29 - SINGLE
 2 THIS
 MEN Locker 2
 WOMEN Locker 2 (opposite)

LOCKER SUMMARY / BILL OF MATERIAL

Item No.	Quantity	Description	Grouping	Color
40	60	12" x 15" x 72" 1-Tile		
76	16	12" x 15" x 36" 2-Tile		
16	15	15" x 72" Sloped Top		
8	15	15" x 15" Sloped Top		
7	15	15" x 72" Sloped Top Band		
7	15	15" x 72" Finisheled Band		
		Women Locker 2		
		Same Material as Above		
		But with one additional		
		Sloped Top Band and Finisheled		
		Band.		

Comments:
 Advise Numbering

Customer Order Number: SECTION 10 INTERNATIONAL Customer: MEDART

Subsidiary of Carriage Industries Inc.

THIS DRAWING AND THE INFORMATION ON IT IS THE CONFIDENTIAL PROPERTY OF THE MEDART COMPANY AND SHALL NOT BE COPIED OR DISCLOSED TO OTHERS WITHOUT WRITTEN PERMISSION. ONLY MEDART RESERVES THE RIGHT TO ALTER AND LIMITS ANY UNAUTHORIZED NOTIFICATIONS RELEASES MEDART FROM ALL LIABILITIES. TOLERANCES UNLESS SPECIFIED DECIMALS #000 DEGREES #1

Description: Shelbyville Recreation Center
 Shelbyville, TN

Drawn By: CDW
 Checked By: [blank]
 Date: 2-4-95
 Scale: 1/4"

Acad Number: [blank]
 Sheet 1 of [blank]
 Drawing Number: [blank]
 Revider: [blank]

Gym

NOTE: COLOR SELECTION AND NUMBERING SEQUENCE MUST BE INDICATED BEFORE THE ORDER CAN BE PUT INTO PRODUCTION.

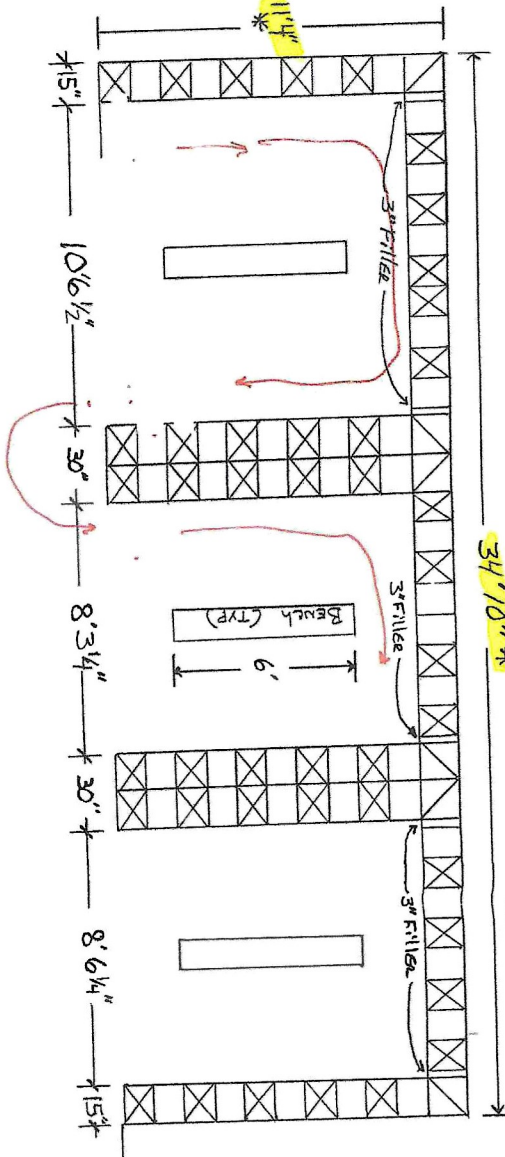

- 12" x 15" x 72" 1-Tier Locker
- 12" x 15" x 36" 2-Tier Locker
- 15" x 15" Sloped Top Counselor Filler

2 Thus
WOMEN LOCKER 1
MEN LOCKER (Opposite)

* FIELD VERIFY

LOCKER SUMMARY / BILL OF MATERIAL

Eq. No.	Quantity	Description	Grouping	Color
43	1	WOMEN LOCKER 1		
86	1	12" x 15" x 72" 1-Tier		
17	1	15" x 72" Sloped Top		
6	1	15" x 15" Sloped Top Counselor		
5	1	15" Sloped Top End		
5	1	15" x 72" Finish End		
		MEN LOCKER 1		
		SAME MATERIAL AS ABOVE		

Wise Numbering

Comment:

Order Number: SECTION 10 INTERNATIONAL Customer:

J.N. #



Subsidiary of Carriage Industries Inc.

THIS DRAWING AND THE INFORMATION ON IT IS THE CONFIDENTIAL PROPERTY OF THE MEDART COMPANY AND SHALL NOT BE REPRODUCED OR DISCLOSED TO OTHERS WITHOUT WRITTEN PERMISSION. MEDART RESERVES THE RIGHT TO ALTER ANY DESIGN OR UNAUTHORIZED MODIFICATIONS RELEASES MEDART FROM ALL LIABILITIES.

TOLERANCES UNLESS SPECIFIED:
FRACTIONS 1/32 DECIMALS .010 DEGREES 1/2

Description: Shelbyville Recreation Center
Shelbyville, TN

Drawn By: DSW	Checked By:	Date: 2-4-95	Scale: 1/4"
Lead Number:		Sheet 1 of 1	Revised:
Drawing Number:			

SINGLE TIER QUIET CORRIDOR LOCKER

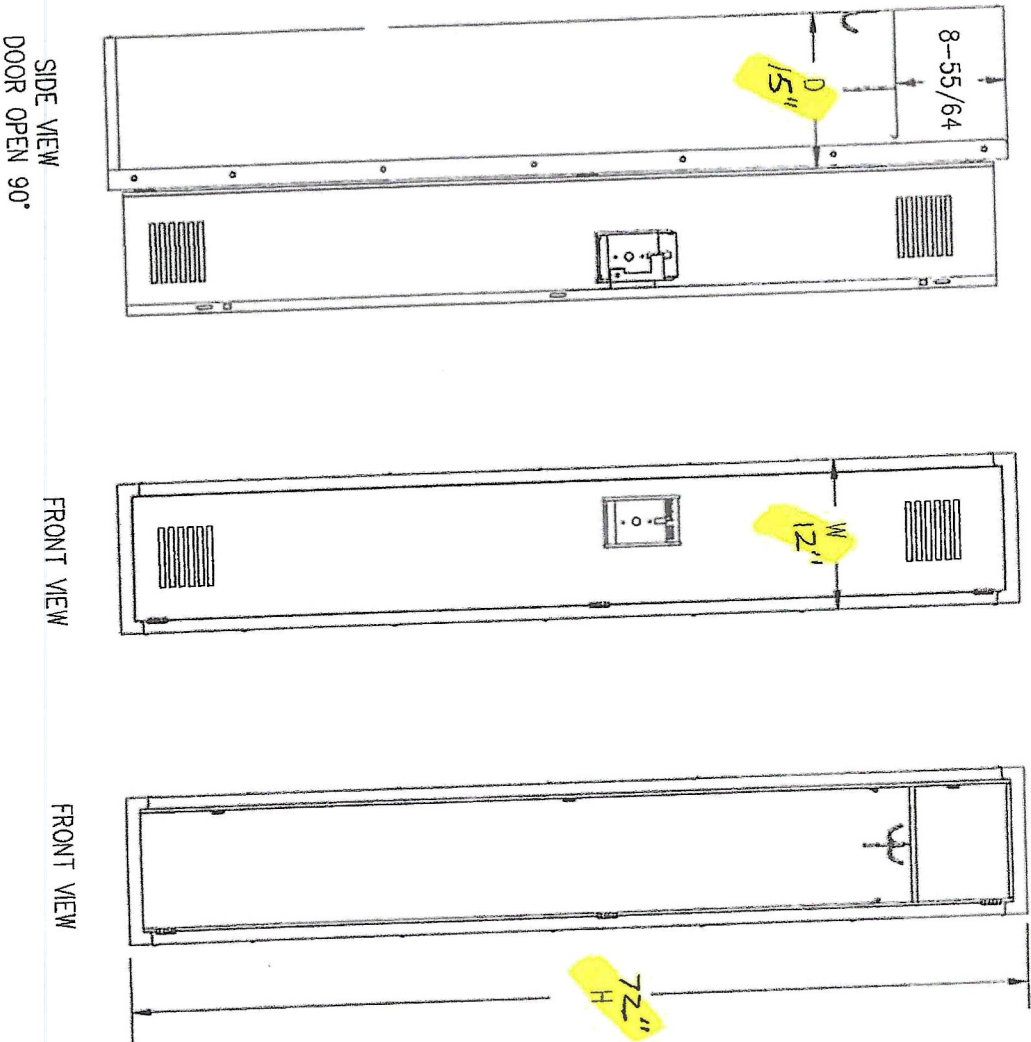

SIDE VIEW
DOOR OPEN 90°

FRONT VIEW

FRONT VIEW

ELEV. NO.: _____

LOCKER DETAILS:

EXT. COLOR (DR/FR) =
 INTERIOR COLOR =
 INTERIOR EQUIP. =

TOP =
 HANDLES =
 LOUVERS =
 BASE =
 LOCKERS TO BE ANCHORED
 TO WALL BY THE ERECTOR

GAUGES
 DOOR = 16
 UPRIGHTS = 14GA W/ VERT. DOORSTRIKE
 CROSSBAR=16
 TOP = 20
 BOTTOM = 20
 SIDE = 24 - EXPOSED 16 GA.
 BACKS = 24
 SHELF = 24
 HINGE = 2" FULL LOOP

COMMENTS:



Subsidiary of Carriage Industries, Inc.

JOB NAME	
ARCHITECT	
LOCATION	
CONTRACTOR	
SALES REP.	
DATE	
SHEET OF	

HOOD AND TOPS

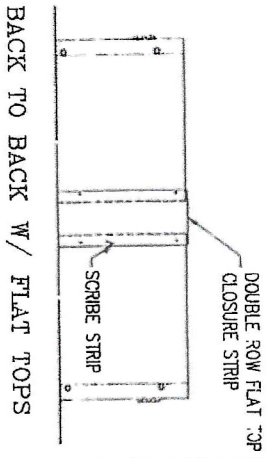

BACK TO BACK W/ FLAT TOPS

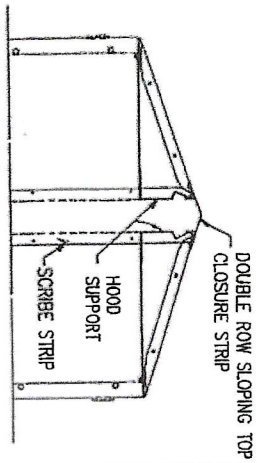

BACK TO BACK W/ SLOPING HOOD

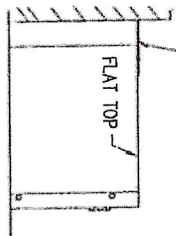

SINGLE ROW W/ FLAT TOP

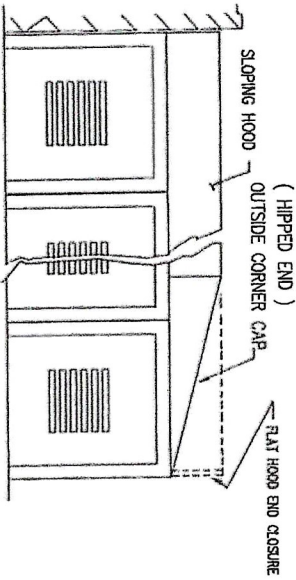

RUN OF LOCKERS FRONT VIEW

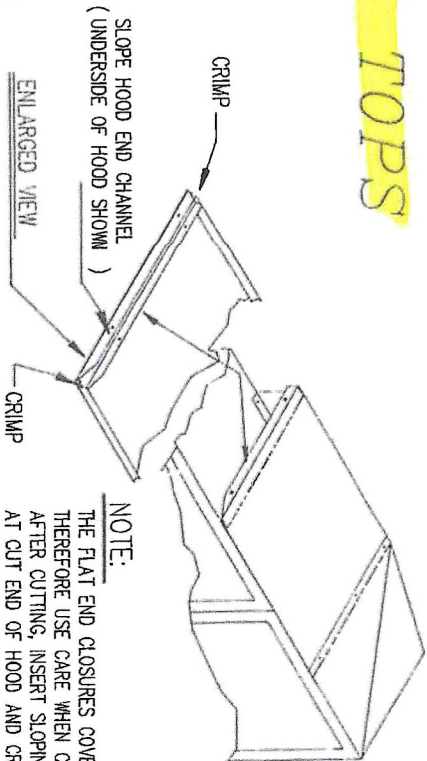

NOTE:
THE FLAT END CLOSURES COVER ONLY 1/4" THEREFORE USE CARE WHEN CUTTING. AFTER CUTTING, INSERT SLOPING HOOD END CHANNEL AT CUT END OF HOOD AND CRIMP FRONT AND REAR HOOD FLANGES INTO CHANNEL TO HOLD (SEE DWG.) CAUTION- DO NOT DEFORM TOP FACE OF HOOD. ASSEMBLE CUT HOOD SAME AS FULL LENGTH HOOD.

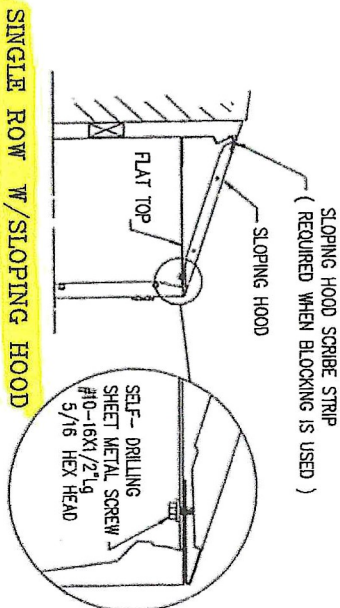

SINGLE ROW W/ SLOPING HOOD

COMMENTS:

STANDARD LOUVER PATTERNS

- 72" ONE TIER 6 LOUVERS AT TOP AND BOTTOM
- 60" ONE TIER 6 LOUVERS AT TOP AND BOTTOM
- 24", 30" AND 36" TWO TIER 3 LOUVERS TOP AND BOTTOM
- 18" FOUR TIER 6 LOUVERS AT BOTTOM
- 15" FOUR TIER 3 LOUVERS AT BOTTOM.
- 20", 24" THREE TIER 3 LOUVERS AT BOTTOM.
- 12" FIVE AND SIX TIER 3 LOUVERS AT BOTTOM.



Subsidiary of Carriage Industries, Inc.

JOB NAME
ARCHITECT
LOCATION
CONTRACTOR
SALES REP.
DATE
SHEET OF

CORNER AND FILLER DETAILS

CUSTOMER MUST SPECIFY FALSE FRONT WHEN FILLER SIZE IS LARGER THAN 12" LOCKER DOOR & FRAME FALSE FRONT

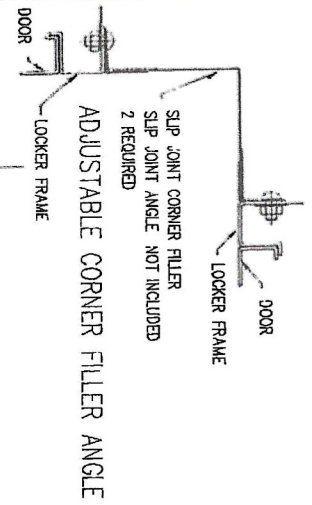
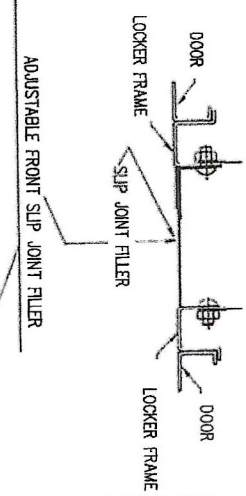
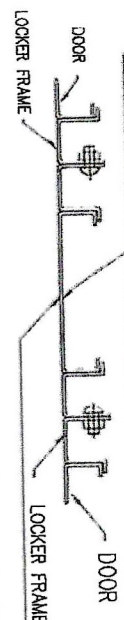

SLIP JOINT ANGLE

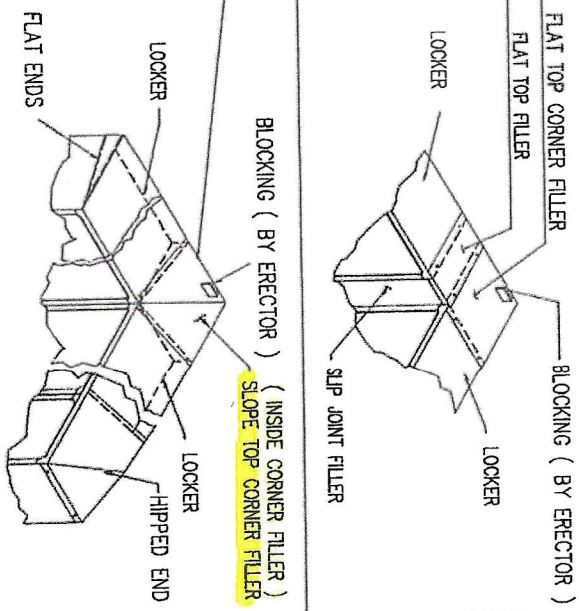
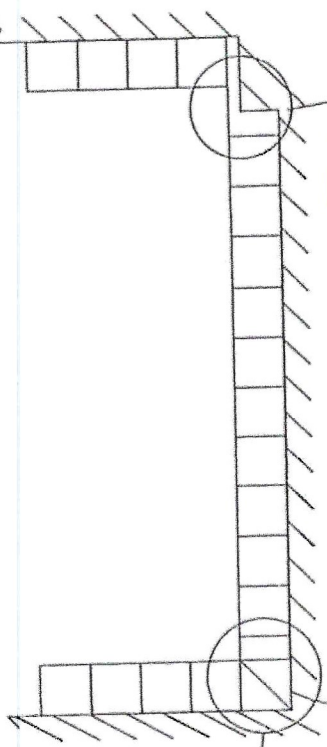
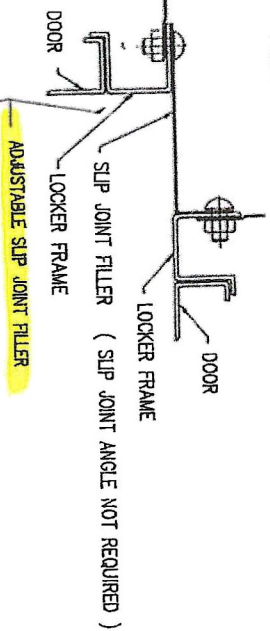
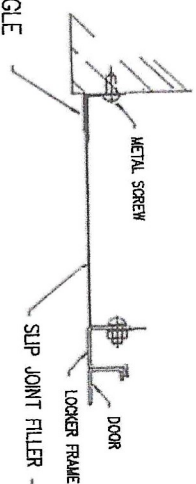

MEDART
Subsidiary of Cargate Industries, Inc.

JOB NAME _____
ARCHITECT _____
LOCATION _____
CONTRACTOR _____
DATE _____
SALES REP. _____
SHEET _____ OF _____