

# INVITATION TO BID



## CITY OF CALLAWAY STORAGE BUILDING REBUILD BID NO: CM2020-02

**ADVERTISED:** The Bay County News Herald, Friday, December 13, 2019

**PREBID MEETING:** N/A

**BID DEADLINE:** 2:00 p.m. Friday, January 10, 2020  
**& OPENING**

**BIDS/PROPOSALS ARE TO BE SUBMITTED TO:**

**CITY OF CALLAWAY  
ATTN: JANICE L. PETERS, CITY CLERK  
6601 EAST HWY. 22  
CALLAWAY, FL 32404**

**BID OPENING:** 2:15 p.m. Friday, January 10, 2020  
Callaway Arts & Conference Center, 500 Callaway Park Way

**ATTACHMENTS:** Notice of Request for Bids/Proposals  
General Instructions and Conditions  
Special Instructions and Conditions  
Minimum Technical Specifications  
Bid Forms (**To be submitted with bid.**):  
Bid/Certification Form  
Public Entity Crimes Statement  
Drug Free Workplace Certification  
Proprietary/Confidential Information Form

  
Janice L. Peters, MMC, City Clerk

## INSTRUCTIONS TO BIDDERS/PROPOSERS

Qualified firms are invited to submit a Bid/Proposal to the **CITY OF CALLAWAY** for the **STORAGE BUILDING REBUILD, BID NO: CM2020-02**, by replying to the enclosed specification. In order for the Bid/Proposal to be considered, complete all items in this specification.

All Bids/Proposals must include one **(1) unbound original** and **five (5) copies** and be addressed to:

CITY OF CALLAWAY  
ATTN: CITY CLERK  
6601 East Hwy. 22  
CALLAWAY, FL 32404

Proposals must be **received** at the address listed above no later than **2:00 p.m. on Friday, January 10, 2020**. Late Proposals will not be accepted, regardless of the reason.

Proposal envelopes must be **sealed and marked** with the RFP number, due date, and name of Proposer so as to identify the enclosed submittal. If more than one package is submitted, please mark "1 of 2", "2 of 2", etc.

### **INTERPRETATION OF SPECIFICATION**

All questions pertaining to the terms and conditions of the scope of work of this Bid/Proposal must be submitted **in writing** via email or fax to the City Clerk as shown below:

Janice L. Peters, MMC, City Clerk  
City of Callaway  
6601 East Hwy. 22  
Callaway, FL 32404  
jlpeters@cityofCallaway.com  
Fax: (850) 871-2444

No oral interpretations will be made to any firm as to the meaning of specifications or any other contract documents. In accordance with Florida Statutes 287.057(23), "Respondents to this solicitation or persons acting on their behalf may not contact, between the release of the solicitation and the end of the 72-hour period following the agency posting the notice of intended award, excluding Saturdays, Sundays, and state holidays, any employee or officer of the executive or legislative branch concerning any aspect of this solicitation, except in writing to the procurement officer or as provided in the solicitation documents. Violation of this provision may be grounds for rejecting a response." Questions must be submitted as referenced above.

All questions must be received at least five (5) calendar days prior to the scheduled opening of Bids/Proposals. Any interpretation of the Bid/Proposal terms, conditions, and/or specification, if made, will be only by Addendum issued by the City Clerk. A copy of such Addendum will be posted to the City's website at [www.cityofcallaway.com](http://www.cityofcallaway.com) and mailed to each proposer that received a copy of the advertisement of the Request for Bids/Proposals. **IT IS THE RESPONSIBILITY OF THE BIDDER/PROPOSER TO CHECK THE CITY'S WEBSITE FOR ANY ADDENDUMS PRIOR TO SUBMITTING A BID/PROPOSAL.** No verbal instructions or interpretations of drawings and specifications will be made other than indicated above.

The City reserves the right to reject any or all proposals, to waive informalities in the Bids/Proposals and to re-advertise for Bids/Proposals. The City also reserves the right to separately accept or reject any item or items of a Bid/Proposal and to award and/or negotiate a contract in the best interest of the City.

# TABLE OF CONTENTS



## **CITY OF CALLAWAY STORAGE BUILDING REBUILD BID NO: CM2020-02**

**Total Pages  
Per Section**

<b>SPECIAL INSTRUCTIONS AND CONDITIONS.....</b>	<b>2</b>
<b>GENERAL INSTRUCTIONS AND CONDITIONS .....</b>	<b>9</b>
<b>MINIMUM TECHNICAL SPECIFICATIONS.....</b>	<b>5</b>
<b>DRAWINGS.....</b>	<b>11</b>
<b>SPECIAL FEDERAL PROVISIONS.....</b>	<b>4</b>
<b>BID/PROPOSAL CHECKLIST .....</b>	<b>1</b>
<b>BID CERTIFICATION FORM .....</b>	<b>2</b>
<b>PUBLIC ENTITY CRIMES STATEMENT.....</b>	<b>2</b>
<b>DRUG-FREE WORKPLACE CERTIFICATION .....</b>	<b>1</b>
<b>PROPRIETARY/CONFIDENTIAL INFORMATION FORM .....</b>	<b>1</b>

# CITY OF CALLAWAY

## SPECIAL INSTRUCTIONS AND CONDITIONS

### STORAGE BUILDING REBUILD BID NO: CM2020-02

\* **Note:** The GENERAL INSTRUCTIONS AND CONDITIONS (attached hereto) apply, except as set forth below, for this Bid.

**A. Description: ( ) See Attached (X) As Follows**

The City of Callaway had a storage building which was a total loss as a result of Hurricane Michael. All debris left from the storage building has all been removed from the site. The Invitation for Bid is for replacement of the storage building pier foundation, exterior wall framing (to include exterior wall covering), roof truss system to include decking of the roof, and porch at entry way. The storage building will be an approximately 672 SF building on a pier foundation. The bid is not to include any electrical, HVAC, or interior furnishings.

**B. Specifications: (X) See Attached ( ) As follows:**

See attached Minimum Technical Specifications (Scope of Work)

**C. Contract/Agreement Required: ( ) None (X) As follows:**

The agreement will be between SynergyNDS and the winning vendor. All contracts and payments will be managed by FMIT/TurnKey Recovery Program managed by SynergyNDS.

**D. Items to be submitted with Bid: ( ) None (X) As follows:**

- Bid/Certification Form(s) with signature page(s).
- Public Entity Crimes Statement.
- State of Florida or County Contractor License/Certification Copy
- Drug Free Workplace Certification.
- One (1) unbound original with five (5) copies of the bid submittal.
- List of Subcontractors, if applicable, and
- List of three (3) references for similar type work with contact information.
- Proprietary/Confidential Information Form

**E. Deadline and place for submission of Bids:**

**2:00 p.m., FRIDAY, JANUARY 10, 2020 (BID DEADLINE)**

**City Hall**

**6601 East Hwy. 22**

**Callaway, FL 32404**

F. Time and place for **OPENING** of Bids:

2:15 p.m., FRIDAY, JANUARY 10, 2020

City of Callaway ARTS & CONFERENCE CENTER - 500 CALLAWAY PARK WAY.

G. Insurance Requirements: ( ) None (X) As follows:

	<u>Minimum Coverage</u>
<u>Property Damage:</u>	\$ 500,000
<u>General Liability:</u>	\$ 1,000,000/2,000,000
<u>Automobile Liability:</u>	\$ 1,000,000/2,000,000
<u>Workers' Compensation:</u>	\$ Statutory Limit*

***Note: Insurance Certificate must be provided by Successful Bidder upon execution of Agreement. City is to be listed on the bidder's/proposer's Certificate of Insurance as additionally insured and certificate holder in order for the City to be notified if the insurance is canceled or modified.***

H. Bond Requirements: ( ) None (X) As follows:

	<u>Amount of Bond</u>
Bid Bond	\$ _____ or <u>5</u> % of Bid
Performance Bond	\$ _____ or <u>N/A</u> % of Bid
Payment Bond	\$ _____ or <u>N/A</u> % of Bid
Construction Bond	\$ _____ or <u>N/A</u> % of Bid
Other: _____	\$ _____ or <u>N/A</u> % of Bid

I. Number of Copies of Bid Forms with original signature(s) Required:

One (1) original, with notarized Signatures, plus five (5) copies

**NOTICE:**

***Proposals may be rejected if all documents are not complete and executed, and the numbers of copies specified/requested of each are not submitted with the proposal.***

# GENERAL INSTRUCTIONS AND CONDITIONS

## (1) NOTICE TO BIDDERS/PROPOSERS

The following general instructions and conditions apply to all Requests for Bids/Proposals unless modified by the provisions set forth in the “**Special Instructions and Conditions**” attached hereto. If there is a conflict between the “Special Instructions and Conditions” and these “General Instructions and Conditions,” the provisions in the Special Instructions and Conditions will apply. **Note: the General Instructions and Conditions and the Special Instructions and Conditions are periodically revised; potential Bidders/Proposers should read both carefully prior to submitting a Bid/Proposal. The attached Special Instructions and Conditions apply only to this Bid/Proposal.**

## (2) SUBMITTAL OF BIDS/PROPOSALS

Qualified businesses or individuals requesting consideration must submit a complete Bid/Proposal with any/all attachments in a sealed package clearly marked with the **name and number of the Bid/Proposal**, to the attention of the City Clerk, prior to closing time at the address shown in the **Special Instructions and Conditions** attached hereto. If not so marked as to this wording, sealed and/or received by the closing time, the Bid/Proposal will not be accepted. Bid/Proposal packages, additional information regarding this Bid/Proposal, or the bidding procedures may be obtained by contacting the City Clerk, 6601 East Hwy. 22, Callaway, FL 32404, (850) 215-6694.

It shall be the sole responsibility of the Bidders/Proposers to have their Bid/Proposal delivered on or before the closing time and date stated in the **Special Instructions and Conditions**. Any Bids/Proposals received after the stated time and/or due to delays caused by mail or courier delivery, or any other reason, shall not be opened or otherwise considered, and will be returned at the bidder's/proposer's expense.

Bids/Proposals shall be opened and publicly announced at the City Clerk's Office, City Hall, 6601 East Hwy. 22, Callaway, Florida, after closing of Bids/Proposals, unless otherwise specified in the Special Instructions and Conditions.

## (3) SPECIFICATIONS AND REQUIREMENTS

The detailed specifications and additional requirements relating to this Bid/Proposal are set forth in the Special Instructions and Conditions attached hereto.

**SILENCE OF SPECIFICATIONS:** The apparent silence of any specification as to any details or any omission of a detailed description concerning any point shall be regarded as meaning that only the best construction practices are to prevail and that only new materials of first quality and correct type, size and design are to be used. All workmanship is to be first quality. All interpretations of specifications shall be made accordingly by the City.

## (4) BID/PROPOSAL FORM

Bidders/Proposers shall complete, sign and furnish the “Bid Certification Form”, together with the forms, specifications and materials required in the “Special Instructions and Conditions” or any exhibits attached hereto. This will include a properly executed Drug-Free Workplace Certification, and a Sworn Statement on Public Entity Crimes Form, pursuant to Section 287.133(3)(a), Florida Statutes. The minimum number of complete Bid/Proposal packages to be submitted is set forth in the Special Instructions and Conditions.

If the "Special Instructions and Conditions" include a "Scope of Work" provision, and/or provide for a supplemental and or implementing agreement, the City reserves the right to modify the "Scope of Services." Further, the terms and conditions of any such agreement shall be modified prior to execution by the City, if such modifications are determined to be in the best interest of the City.

Bids/Proposals may be considered non-responsive, at the sole option of the City, and may be rejected if they include omissions, alterations of form, additions not called for, conditions or limitations, unauthorized alternate Bids/Proposals, submission of less than the number of bid packages requested, or other irregularities of any kind.

Unless otherwise stated, the price(s) set forth in the Bid/Proposal include(s) all costs and expenses for labor, equipment, materials, commissions, transportation charges and expenses, handling material inspection, and patent fees and royalties, together with any and all other costs and expenses for providing the service, equipment, materials or performing and completing the work as shown according to the plans and specifications herein.

If quotations are requested for the various items of work, they are intended to establish a total price for providing the materials, equipment, services, or completing the work in its entirety. If the Bidder/Proposer determines that the cost for any item of work has not been established by the Proposal Form, the cost for that work is to be included in other applicable Bid/Proposal item(s), so that the Bid/Proposal reflects the total price for completing that work in its entirety.

In the event of a discrepancy between a unit bid price and an extension, the unit bid price will govern. Written prices shall govern over figures.

**(5) CLARIFICATION AND ADDENDA**

Each Bidder/Proposer shall examine all Bid/Proposal documents and shall judge all matters relating to the adequacy and accuracy of such documents. Any inquiries, suggestions or requests concerning the interpretation, clarification or additional information pertaining to this Invitation to Bid/Request for Bid/Proposal will be accepted by the City Clerk up to and including five (5) working days prior to the closing date and time stated herein. The issuance of a written addendum signed by the City Clerk is the only official method whereby interpretation, clarification or additional information can be given. The City shall not be responsible for oral interpretations given by any City employee, representative or others. If any addenda are issued, the City will attempt to notify all known prospective Bidders/Proposers. However, it shall be the responsibility of each Bidder/Proposer, prior to submitting a Bid/Proposal, to contact the City Clerk's Office to determine if addenda were issued, and to make such addenda a part of the Bid/Proposal. If an addendum has been issued, and was not incorporated in the Bid/Proposal documents submitted by Bidder/Proposer, the Bid/Proposal may not be accepted or considered by the City.

**(6) MANUFACTURER'S NAMES AND APPROVED EQUIVALENTS**

Unless otherwise specifically stated in the Special Instructions and Conditions, any manufacturer's names, trade names, brand names, catalog numbers, or similar information listed in a specification, are for the purpose of information and illustration, and are not intended to restrict the submission of alternates meeting minimum specifications. The Bidder/Proposer may offer the same or any alternate for which the Bidder/Proposer is an authorized representative, which meets or exceeds the specifications for any item. If a manufacturer's name or model is included in the specification, and a Bid/Proposal is based on alternate products or services which Bidder/Proposer maintains is equivalent and meets or exceeds specifications, Bidder/Proposer is to indicate on the Bid/Proposal Form the manufacturer's name and related information of the alternate; including any

deviation from the specifications. Unless expressly noted on the Bid/Proposal that an alternate is being proposed, and the specification includes a specific manufacturer's model or brand, the Bid/Proposal will be considered as a quotation for the item(s) stated in the specifications.

**(7) INFORMATION AND DESCRIPTIVE LITERATURE**

Bidders/Proposers must furnish all information requested in the Bid/Proposal packet including but not limited to any sketches, plans, designs, specification, and descriptive literature regarding the product(s)/service(s) being offered. Bids/Proposals which do not comply with these requirements are subject to rejection. Reference to submission of documentation or materials with a previous Bid/Proposal will not satisfy this provision.

**(8) BONDS/INSURANCE**

If the Bid/Proposal is accepted by the City, it will become a binding contract on both parties. If a bond or cashiers/certified check is required as a bond, it shall be submitted with the Bid/Proposal. If the undersigned shall fail to deliver or perform, or if applicable, execute a contract if provided for herein, then the City may, at its option, determine that the undersigned has abandoned the award/contract, and thereupon such acceptance of the Bid/Proposal and/or award shall be null and void, and any cashiers/certified check or bond accompanying this Bid/Proposal shall be forfeited to and become the property of the City. The full amount of said check, or if a bond, the full amount of such bond, shall be paid to the City as partial liquidated damages; otherwise, any bond or cashiers/certified check accompanying this Bid/Proposal shall be returned to the undersigned within 30 calendar days from the date of award, or if provisions for a Notice to Proceed are included, from the date of the Notice to Proceed.

If a bid or proposal bond is required, the bonds of unsuccessful Bidders/Proposers will be returned within 30 calendar days of the Bid/Proposal due date, except as set forth below.

If a proposal is subject to the Competitive Negotiations Act, the bonds will be returned within 60 days of the proposal due date, except for the bond of the 3 highest ranked proposers. Within 30 days of execution of a contract, bonds from the remaining unsuccessful proposers will be returned.

Bid bond, if required, will be returned within 30 calendar days of delivery/acceptance of the item(s) bid or service(s) provided, unless a standard payment and performance bond is required. When a standard Payment and Performance Bond is required, the bid bond of the successful Bidder/Proposer will be returned within 30 calendar days from the date of the Notice to Proceed.

In the event a bid is awarded, a proposal is accepted, and/or a contract is executed, and the Bidder/Proposer chooses not to proceed, or fails to perform for any reason, the bond will be forfeited and retained by the City as partial liquidated damages. Future Bids/Proposals will not be accepted for consideration from the Bidder/Proposer for five (5) years, or such shorter period as the City Commission may determine.

In the event an award/selection is not made within 90 days after the Bid/Proposal due date and the City does not return all bonds, upon 30 business days written request, a bidders/proposer may withdraw their bid or proposal from consideration, and obtain a refund of the Bid/Proposal bond.

All Awards will be subject to presentation of any required performance bond or certificate of insurance prior to any purchase authorizations, agreements, contract documents, or delivery. The Bidder/Proposer shall maintain any performance bonds or insurance coverage set forth in the Special Instructions and Conditions, at its own expense. If insurance is required, the City is to be listed on the bidder/proposer's Certificate of Insurance as an additional insured and certificate holder in order that the City will be notified if the insurance is canceled or



modified. The certificate shall also list the name of the project/service/equipment purchased, and the expiration date of the policy. At the City's option, an award may be canceled and any bid bond forfeited if any required performance bond or insurance certificate is not delivered within 21 calendar days of the date of award.

***Note:** The provisions of this section are in addition to and not a replacement for, any Bid/Proposal and/or performance bond required in the Special Instructions and Conditions. The foregoing provisions are intended to be in addition to any other legal remedy available to the City for non-performance by a Bidder/Proposer subsequent to the acceptance and/or award of a bid or proposal.*

**(9) SERVICE AND WARRANTY**

If any warranty repair or replacement service is requested in the Special Instructions and Conditions, any deviation or limitation from the requirements is to be expressly stated on the Bid Request for Proposal Certification Form.

If the service or product provided to the City pursuant to the bid consists of computer hardware, software or firmware, the Bidder/Proposer warrants that said product will accurately process/or reflect data from, into and between the twentieth and twenty-first centuries, including leap-year calculations.

**(10) CONTRACT FORMS**

Any agreement or contract resulting from the acceptance of a Bid/Proposal shall be on forms either supplied by or approved by the City, and shall contain, as a minimum, applicable provisions of the Invitation to Bid/Request for Proposal, and the Bid/Proposal documents to be submitted by Bidder/Proposer, including the Special Instructions and Conditions, General Instructions and Conditions, and all attachments therewith. The City reserves the right to reject any Bid/Proposal or resulting agreement which does not conform to the Invitation to Bid/Proposal and, if applicable, any City requirement relating to such an Agreement.

The City reserves the right to extend any contract or agreement for an additional period of not more than ninety (90) days beyond the original expiration date. Prices in effect on the last day of the contract shall remain in effect for the contract extension period. Additional extensions shall be subject to agreement of both parties.

The successful Bidder/Proposer will be required to execute any resulting agreement and provide any bonds or insurance certificates required within 10 days of contract execution. Failure to timely execute the necessary bond or insurance certificate will result in cancellation of an award, with no further obligation by the City.

This Bid/Proposal is subject to the appropriation of funds in an amount sufficient to allow continuation of the City's performance in accordance with the terms and conditions of this Bid/Proposal for each and every fiscal year in which this Bid/Proposal is executed and entered into. If funds are not appropriated/available, the City shall provide prompt written notice to the selected Bidder/Proposer that effective thirty (30) days after giving such notice, or upon the expiration of the time for which funds were appropriated, whichever occurs first, the City will thereafter be released of all further obligations related to the Bid/Proposal and/or award.

**(11) BID/PROPOSAL EXPENSES**

All expenses for preparing and submitting Bids/Proposals to the City are to be borne by the Bidder/Proposer.

**(12) VARIANCES**

Any variance whatsoever from the Bid/Proposal Specifications are to be clearly identified on the Bid/Proposal form. Acceptance of any proposed variations will be at the sole discretion of the City.

**(13) CONFLICT OF INTEREST**

The award of a bid or acceptance of proposal is subject to Chapter 112, Florida Statutes. All Bidders/Proposers must disclose with their Bid/Proposal the name of any officer, director, or agent who is a city official or employee, or a member of an official's or employee's immediate family. Further, Bidders/Proposers must disclose the name of any city official or employee, or a member of an official's or employee's immediate family, who owns directly or indirectly an interest of ten percent (10%) or more in the bidder's/proposer's firm or related business.

**(14) DELIVERY**

All items provided pursuant to an award are to be delivered prepaid to the City Clerk's Office, 6601 East Hwy. 22, Callaway, Florida 32404-2041, unless a different location is specified in the Special Instructions and Conditions. All delivery charges are to be included in the Bid/Proposal price. No Collect on Delivery (C.O.D.) will be accepted. Title and risk of loss or damage to all items shall be the responsibility of the Bidder/Proposer until delivered to the City.

**(15) INSPECTION, ACCEPTANCE AND TITLE**

All items delivered pursuant to an award are subject to inspection and review prior to acceptance by the City. Acceptance, evidenced by separately written Notice of Acceptance or full payment, will be made only after verification of compliance with all specifications. Acknowledgment of delivery and/or partial payment does not constitute acceptance.

**(16) OWNERSHIP RIGHTS AND PUBLIC RECORDS LAW**

Public Records Law. Bidder/Proposer acknowledges that they are familiar with the provisions of the Public Records Law of the State of Florida.

Bidder/Proposer agrees to comply with Chapter 119, Florida Statutes, and specifically per Florida Statute 119.0701, Bidder/Proposer agrees to keep and maintain public records that would be required by the City of Callaway in order to perform the services provided for in this agreement; Bidder/Proposer agrees to provide public access to any required public records in the same manner as a public agency; Bidder/Proposer agrees to protect exempt or confidential records from disclosure; Bidder/Proposer agrees to meet public records retention requirement; and Bidder/Proposer agrees that at the end of the term of this agreement, to transfer all public records to the City of Callaway and destroy any duplicate, exempt or confidential public records.

All products generated by the Bidder/Proposer for the City become the property of the City. The City may require submission of any electronic file version of reports, data, maps, or other submission of documentation produced for or as a result of this Bid/Proposal in addition to paper documents.

Further, in accordance with the Public Records Laws of the State of Florida, Section 119.0701, (2013), Contractor must:

- A. Keep and maintain public records that ordinarily and necessarily would be required by the public agency in order to perform the service.
- B. Provide the public with access to public records on the same terms and conditions that the public agency would provide the records and at a cost that does not exceed the cost provided in this chapter or as otherwise provided by law.
- C. Ensure that public records that are exempt or confidential and exempt from public records are not disclosed except as authorized by law.
- D. Meet all requirements for retaining public records and transfer, at no cost, to the public agency all public records in possession of the contractor upon termination of the contract and destroy any duplicate public records that are exempt or confidential and exempt from public record disclosure requirements. All records stored electronically must be provided to the public agency in a format that is compatible with the information technology systems of the public agency.
- E. If a contractor does not comply with a public records request, the public agency shall enforce the contract provision in accordance with the contract.

**(17) RESERVED RIGHTS**

The City reserves the right to reject any and all Bids/Proposals, with or without statement of cause, request resubmissions, or to waive any irregularities or technicality or negotiate modifications to any Bid/Proposal which may be in the best interest of the City.

Bidders/Proposers which do not normally engage in providing the types of commodities/services specified herein may be required to demonstrate they have sufficient financial support, equipment, and organization to ensure they can satisfactorily perform if awarded a bid/contract under the terms and conditions herein stated.

The City reserves the right to make such investigations as it deems necessary to determine the ability of any Bidder/Proposer to perform the work or service requested. Any information the City deems necessary to make such determinations shall be provided by the Bidder/Proposer upon request as a condition of further consideration of the Bid/Proposal. The applicability of all information obtained and the City's decision shall be final. By submitting a bid or proposal, Bidder/Proposer authorizes such investigation.

If the contract awarded as a result of this bid is terminated prior to the end of the term, the City reserves the right to award the balance of the contract to the next lowest responsive and responsible bidder.

**(18) ADVERTISING**

In submitting a Bid/Proposal, Bidder/Proposer agrees not to use the results therefrom as a part of any commercial advertising or marketing purposes without written approval of the City Manager.

**(19) GOVERNMENTAL RESTRICTIONS/REQUIREMENTS**

In the event any governmental restrictions are imposed which would necessitate alteration of the material, quality, workmanship, or performance of the items offered in a Bid/Proposal, it shall be the responsibility of the successful Bidder/Proposer to immediately notify the City of the specific regulation which required an

alteration, and the specific alterations that will be made to the item(s) bid/proposed. The City reserves the right to accept any such alteration/substitution, including any price adjustments resulting therefrom, or to cancel the award at no expense to the City.

**(20) NON-DISCRIMINATION**

There shall be no discrimination as to race, sex, color, creed, handicap, or national origin in the selection, award, or operations conducted, or performance related to any bid or proposal.

**(21) UNAUTHORIZED EMPLOYEES OR AGENTS**

Employment of unauthorized aliens by Bidder/Proposer is considered a violation of Section 274A(e) of the Immigration and Nationality Act. If selected Bidder/Proposer knowingly employs unauthorized aliens, such action shall be cause for unilateral cancellation of this agreement and the City may recover damages from selected Bidder/Proposer resulting from such cancellation. The selected Bidder/Proposer shall be responsible for including this provision in any context with, and requiring compliance by any/all subcontracts performing for selected Bidder/Proposer relating to this agreement.

**(22) OTHER GOVERNMENTAL ENTITIES - OPTIONAL APPLICATION**

In the State of Florida, other Florida public entities may “piggy-back” on competitive Bid/Proposal awards under the same terms and conditions, if all parties are in agreement.

**(23) LEGAL NAME**

Bids/Proposals shall clearly indicate the legal name and organizational structure, business address, telephone number, and email address of the Bidder/Proposer. Bids/Proposals shall be signed above the typed or printed name and title of the individual submitting the Bid/Proposal. The signer shall warrant he/she has the authority to bind the Bidder/Proposer to the terms and conditions of the submitted Bid/Proposal.

**(24) WAGES**

State and Federal minimum wage and hour regulation apply to Bidder/Proposer and all subcontractors.

**(25) SELECTION**

The City intends to award this bid to the lowest responsive and responsible bidder or bidders. However, the City reserves the right to reject any and all Bids/Proposals. The procedures for the selection/award of Bids/Proposals are provided for by Florida Statutes and the City’s Charter, Code of Ordinances, and Administrative Policies. Generally, all Bids/Proposals are reviewed by City staff and evaluated by the City Manager, and if required by law, by a Selection Advisory Committee appointed by the City Manager. The type and price of the product(s) or service(s) being acquired determines if an award or selection may be made by the City Manager or requires City Commission approval. For information on which procedure applies to a particular Bid/Proposal contact the City Clerk.

Bids/Proposals will be evaluated based on, but not limited to, one or more of the following criteria as appropriate:

- compliance with specifications,
- price (if applicable),

- capability/adequacy of Bidder/Proposer,
- past and current projects, services or equipment provided to the City,
- delivery schedule,
- prior government projects, services or equipment provided to other jurisdictions, and
- general reputation, location and references.

Separate procedures and requirements relating to Requests for Bids/Proposals/Qualifications apply for certain grant programs and for professional services, for example the Consultants' Competitive Negotiation Act (Florida Statute 287.055), and by the City's Code. When the City initiates such a Request for Proposals/Qualifications, the selection process and related procedures are included in the Special Instructions and Conditions.

Pursuant to Chapter 287.087 Florida Statutes, in the event two (2) or more bids are equal with respect to price, quantity, and services, preference will be given to Bidders/Proposers which have implemented Drug-Free Workplace Programs.

Further, per 287.087(11) "If two equal responses to a solicitation or a request for quote are received and one response is from a certified minority business enterprise, the agency shall enter into a contract with the certified minority business enterprise." In addition, at the sole discretion of the City, payment terms, conditions, and other consequential information may be utilized in resolving apparent tie Bids/Proposals.

**NOTE: For consideration, Bidder/Proposer must return the Bid Certification Form included in the Bid/Proposal package.**

**(26) INDEMNIFY**

After notification of award, the successful Bidder/Proposer agrees to defend, indemnify and hold harmless the City and its officials, officers, employees, agents, and invites, from and against all claims, suits, sections, damages, or causes of action arising from any personal injury, loss of life or damage to property, sustained by reason of, or as a result of constructing, manufacturing, processing, delivery, or performance of the services or work for which the Bid/Proposal was awarded or any resulting agreement executed, and from and against any orders, judgments, or decrees which may be entered thereto, and from and against all costs, attorney's fees, expenses, and liabilities incurred in or by reason of the defense of any such claim, suit or action, and the investigation thereof. Nothing in any resulting agreement shall be deemed to affect the rights, privileges and immunities of the City of Callaway.

The selected Bidder/Proposer, without exception, shall also indemnify and hold harmless the City and its officials, employees, agents, and invites from liability of any nature or kind, including cost and expenses for or on account of any copyrighted, patented or unpatented invention, process or article manufactured or used in the performance of the contract, including its use by the City. If the selected Bidder/Proposer uses any design, device or materials covered by patent or copyright, it is mutually agreed and understood that the Bid/Proposal prices include all royalties or costs arising from the use in any way of such design, device or materials involved in the product and/or services provided to the City.

**(27) MODIFICATION - AFTER AWARD**

Any changes proposed by a Bidder/Proposer after an award in (a) materials used, (b) manufacturing process, (c) construction or (d) specifications, are to be submitted in writing to the City Manager prior to delivery. No changes shall be approved and binding upon the City unless evidenced by a Change Order issued and signed by the City Manager.

**(28) ASSIGNMENT**

Any purchase order issued pursuant to this bid invitation/request for proposal and the funds which may become due hereunder, are not assignable, except with the prior written approval of the City Manager.

**(29) DISCLOSURE**

Bidder/Proposer acknowledges by submitting a Bid/Proposal that all information provided to the City is part of the public domain as defined by Florida Statutes and is considered a public record. Information should not be labeled "confidential," unless specifically exempted under said Statutes, and exempts the City from any liability for releasing all information to the public, including inadvertently releasing information deemed confidential by the Bidder/Proposer.

**(30) TAXES**

The City is a tax-exempt Florida municipality, Federal Employment Identification Number 59-6000-284, Florida State Tax Number 37-02-008131-54C. Copies of Exemption Certificate and related information may be obtained by contacting the City Clerk, City of Callaway, 6601 East Hwy. 22, Callaway, Florida 32404-2041 or (850) 215-6694.

**(31) APPLICABLE LAWS/LEGAL VENUE**

All applicable laws, regulations and ordinances of the State of Florida, Bay County and the City of Callaway will apply to consideration and award of any Bid/Proposal and the performance of the Bidder/Proposer pursuant thereto, and shall be governed by the laws of the State of Florida both as to intention and performance. The venue for any action arising from the award or subsequent performance shall lie exclusively in the Circuit Court of Bay County, Florida, or the United States District Court for the Northern District of Florida, as applicable.

***NOTE: ANY AND ALL PROVISIONS SET FORTH IN THE SPECIAL INSTRUCTIONS AND CONDITIONS ATTACHED HERETO, WHICH VARY FROM THESE GENERAL INSTRUCTIONS AND CONDITIONS, SHALL HAVE PRECEDENCE.***

**CITY OF CALLAWAY  
STORAGE BUILDING REBUILD  
BID NO: CM2020-02**

**MINIMUM TECHNICAL  
SPECIFICATIONS**

# INVITATION FOR BID (IFB)

## GC2018092542-007005-Exhibit A

**Project Summary:** The City of Callaway had a storage building which was a total loss as a result of Hurricane Michael. All debris left from the storage building have all been removed from the site. The Invitation for Bid is for the replacement of the storage building pier foundation, exterior wall framing (to include exterior wall covering), roof truss system to include decking of the roof, and porch at entry way. The storage building is approximately 672 SF building on a pier foundation. The bid is not to include any electrical, HVAC, or interior furnishings.

**Bidding Information:**

Bids are to be returned in a sealed envelope to:  
City of Callaway City Clerk's Office  
Bid No.: CM2020-02  
Re: SynergyNDS – Storage Building Rebuild - 007005  
6601 E. Hwy 22  
Callaway, FL 32404

**Request for Information:**

Questions or requests for information shall be made in writing to City Clerk Janice Peters at [jpeters@cityofcallaway.com](mailto:jpeters@cityofcallaway.com).

**Location:**

Storage Building  
522 Beulah Ave.  
Callaway, FL 32404

**Work Scope:**

- Contractor shall coordinate all work with SynergyNDS.
- All construction materials must meet the requirements of the attached engineering plans and/or those required by local ordinances & laws; whichever is the more stringent.
- Contractor shall provide appropriate pier foundation system as indicated in the attached engineer plans.
  - Height shall be determined to ensure that finished floor height is equal to that of the existing adjacent building.
  - Piers shall be set in locations as identified in the attached engineer plans.
  - Piers shall be constructed with materials and fasteners as indicated in the attached engineer plans.
- Install required floor joist system and fasten appropriately to the pier foundation system.
  - Height shall be determined to ensure that finished floor height is equal to that of the existing adjacent building.



# INVITATION FOR BID (IFB)

## GC2018092542-007005-Exhibit A

- Install  $\frac{3}{4}$ " T&G plywood flooring substrate across all floor joist. (Ex. Advantech)
  - Prior to installation of flooring substrate, contractor shall allow city time to have appropriate termite treatment completed.
  - Plywood substrate shall be installed with staggered joints.
  - All plywood is to be glued and nailed for purpose of securing to floor joist.
- Construct and install all required exterior walls.
  - Framing to constructed with 2"x6" dimensional lumber.
  - Wall height shall match that of the existing to ensure that the current roof lines match to that of the existing roof line.
  - All framing shall be on maximum 16" on center.
  - Framing is to tie into the existing building where indicated.
    - Siding of the existing building is to stay in place.
  - Framing is to be secured with all required hurricane straps, all thread, and other methods as indicated in the attached engineer plans.
  - All headers shall be constructed accordingly and secured with all required hurricane straps.
  - All blocking should be installed where required.
- Install  $\frac{1}{2}$ " wood wall sheathing for all exterior walls.
  - Wall sheathing shall meet the requirements of the plans and installed in accordance with the plans.
  - Sheathing maybe installed horizontally or vertically.
  - Joints shall be staggered where required.
  - Wall sheathing shall be wrapped with approved vapor barrier and secured appropriately.
- Exterior Wall Coverings:
  - Exterior wall coverings shall be completed with matching wood lap siding as currently present on the existing adjacent building.
  - Lap siding to continue into the gable end to the peak of the roof line.
  - Lap siding shall terminate flush to the current corner trim on the existing building on the back side of the building.
  - Lap siding shall terminate into the side of the existing building on the front side of the new building with appropriate trim.
  - All exterior trim shall be 1"x4" dimensional lumber to match that of the existing adjacent building.
- Roof Framing:
  - Trusses to match the pitch and height of the existing roof lines of the adjacent building.
  - Trusses to be attached with all required hurricane straps per required codes.

# INVITATION FOR BID (IFB)

## GC2018092542-007005-Exhibit A

- Roof sheathing to be 5/8" approved sheathing nailed per code requirements.
- Roof to be constructed as a gable roof style.
- All soffit and fascia to be installed per drawings.
- Doors & Windows:
  - Install required impact resistant windows in sizes and quantities as identified in the attached plans.
    - Windows are to be constructed with a wood frame of similar design to existing adjacent building.
    - Windows must meet required codes for location of the building.
  - Install exterior doors in size and swing as identified.
    - Any glass in doors shall be impact resistant which meet all code requirements.
  - All windows and doors shall be trimmed out with matching trim as that of the adjacent existing building.
- Porch:
  - Approximately 407 SF of porch to be built on the front elevation.
  - Front porch to tie into the existing porch with roof lines to match that of the existing.
  - Rear steps to be constructed as identified.
- General Notes:
  - Florida Product Approval Sheets for all products is required to be provided with bid.
  - All warranty information for proposed materials shall be provided at time of contract award prior to release of any funds. (Where applicable).
  - Contractor shall keep the site clean and tidy at all times.
  - Dumpsters will be provided on site by SynergyNDS.

### **Reminder Notes:**

1. Contractor is responsible to validate all quantities and units of measurements specific to the scope items above. Information above is intended as a general guidance purpose only.
2. Contractor has the sole responsibility to ensure that all services and materials for bid submittal meet all codes and standards. This include that all work must be completed in order to meet all codes and standards.
3. Contractor should also consider method to stock/store materials at the jobsite in a safe and secure manner. SynergyNDS will not be responsible for lost or stolen materials, supplies, or equipment from the location.
4. Contractor is strongly encouraged to schedule a site visit of the property as necessary to support the IFB submittal.

# **INVITATION FOR BID (IFB)**

## **GC2018092542-007005-Exhibit A**

5. Contractor can submit request for site visit to the specific IFB by emailing: [bids@synergynds.com](mailto:bids@synergynds.com)

# RENNOVATIONS FOR: CALLAWAY HISTORIC SOCIETY 522 BEULAH AVE. CALLAWAY, FLORIDA

**PROJECT INFO:**  
 PARCEL NUMBER - 06947-010-000  
 LAND USE ZONING - RECREATIONAL (CAL)  
 FLOOD ZONE - AO  
 SQ. FT. CALCULATIONS:  
 TOTAL HEATED AND COOLED - 1,361 SQ. FT.  
 TOTAL AREA UNDER ROOF - 2,021 SQ.FT.  
 NEW CONSTRUCTION TOTAL AREA - 916 SQ. FT.  
 AREA OF LOT - 479,552 SQ. FT. (11,009 ACRES)  
 IMPERVIOUS AREA - 4%

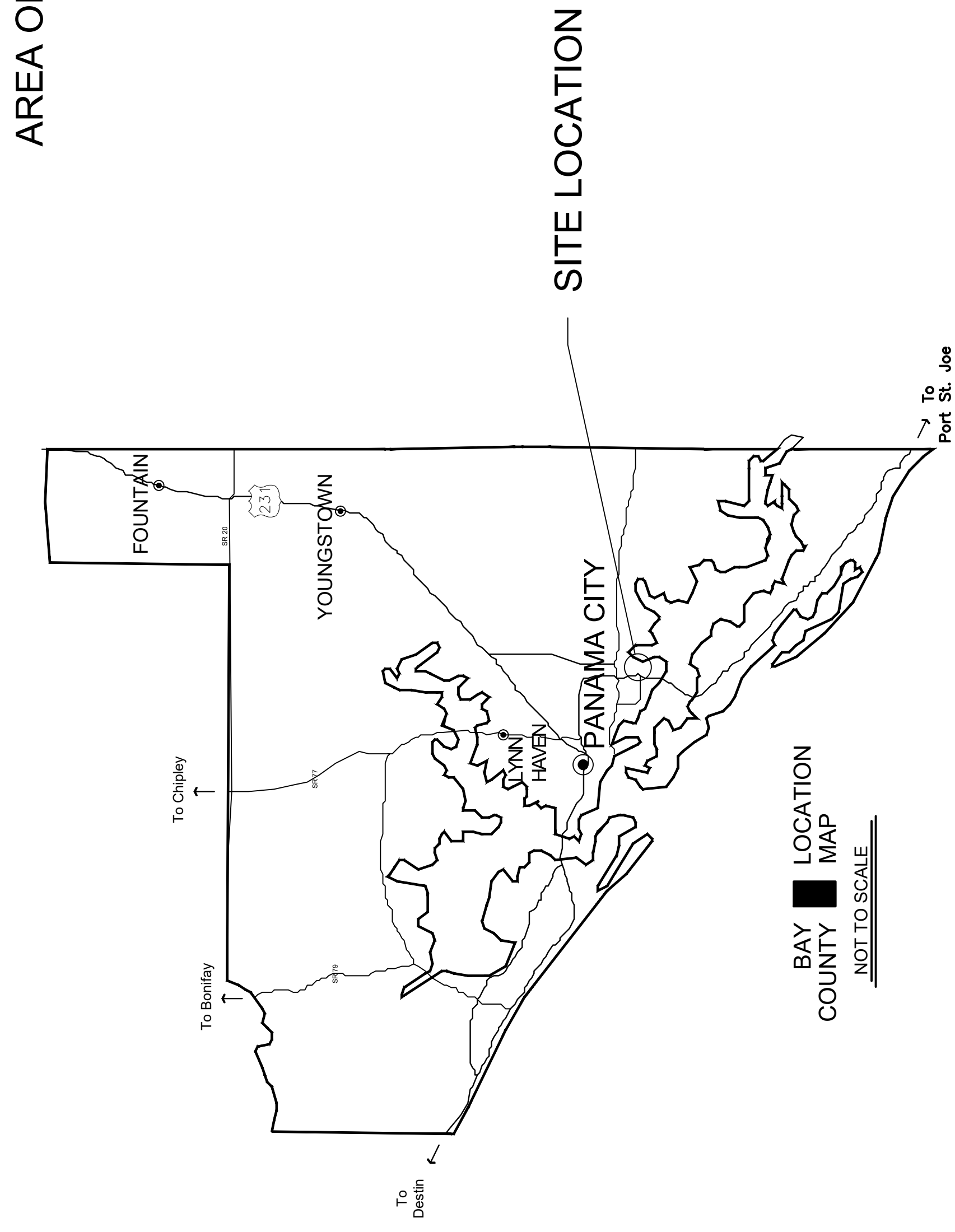

AREA OF CONSTRUCTION  
(SEE SHEET C0.1)



## TABLE OF CONTENTS

COVER SHEET / LOCATION MAP	C0.0
SITE PLAN	C0.1
EXISTING / DEMO PLAN	A1.0
PROPOSED FLOOR PLAN	A1.1
ELEVATIONS	A2.0
STRUCTURAL NOTES	S1.0
FLOOR FRAMING PLAN	S2.0
ROOF PLAN	S2.1
STRUCTURAL SECTIONS	S3.0
WALL CONNECTION DETAILS	S3.1
ELECTRICAL PLAN	E1.0



**WEBER**  
 structural engineering  
 3000 W. 25th Street  
 Panama City, FL 32405  
 mkweb@mkweb.com

Michael K. Weber P.E.  
 FL P.E. #75798

REVISIONS:	COMMENTS:	DATE:

RENNOVATIONS FOR:  
 CALLAWAY HISTORIC SOCIETY  
 522 BEULAH AVE.  
 CALLAWAY, FLORIDA

COVER SHEET

12/4/2019  
 Project No. 18330  
 Drawn By: JCC  
 Checked By: MKW

Drawing Number  
**C0.0**

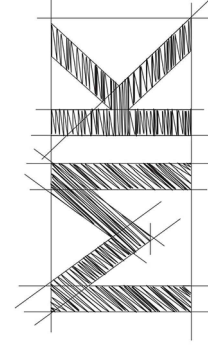

**WEBER**  
structural engineering  
3000 W. 23rd Street  
Palm City, FL 32905  
mweber.com

Michael K. Weber P.E.  
FL P.E. #75798

REVISIONS:	COMMENTS:	DATE:

RENOVATIONS FOR:  
CALLAWAY HISTORIC SOCIETY  
522 BEULAH AVE.  
CALLAWAY, FLORIDA

SITE PLAN

12/4/2019

Project No.: 19330  
Drawn By: JCC  
Checked By: MKW

Drawing Number  
**C0.1**

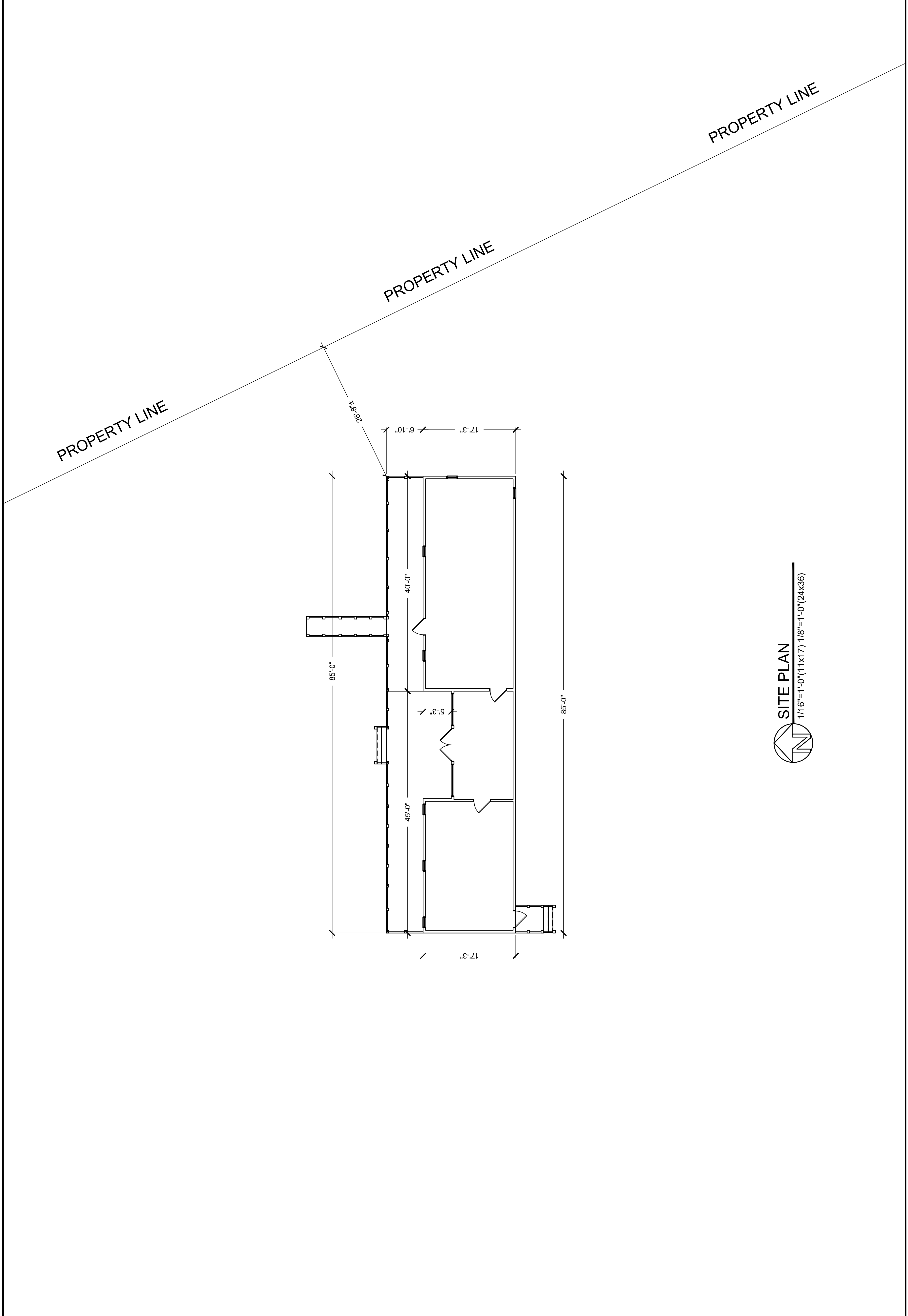

**SITE PLAN**  
1/16"=1'-0" (11x17) 1/8"=1'-0" (24x36)

REVISIONS:	COMMENTS:	DATE:

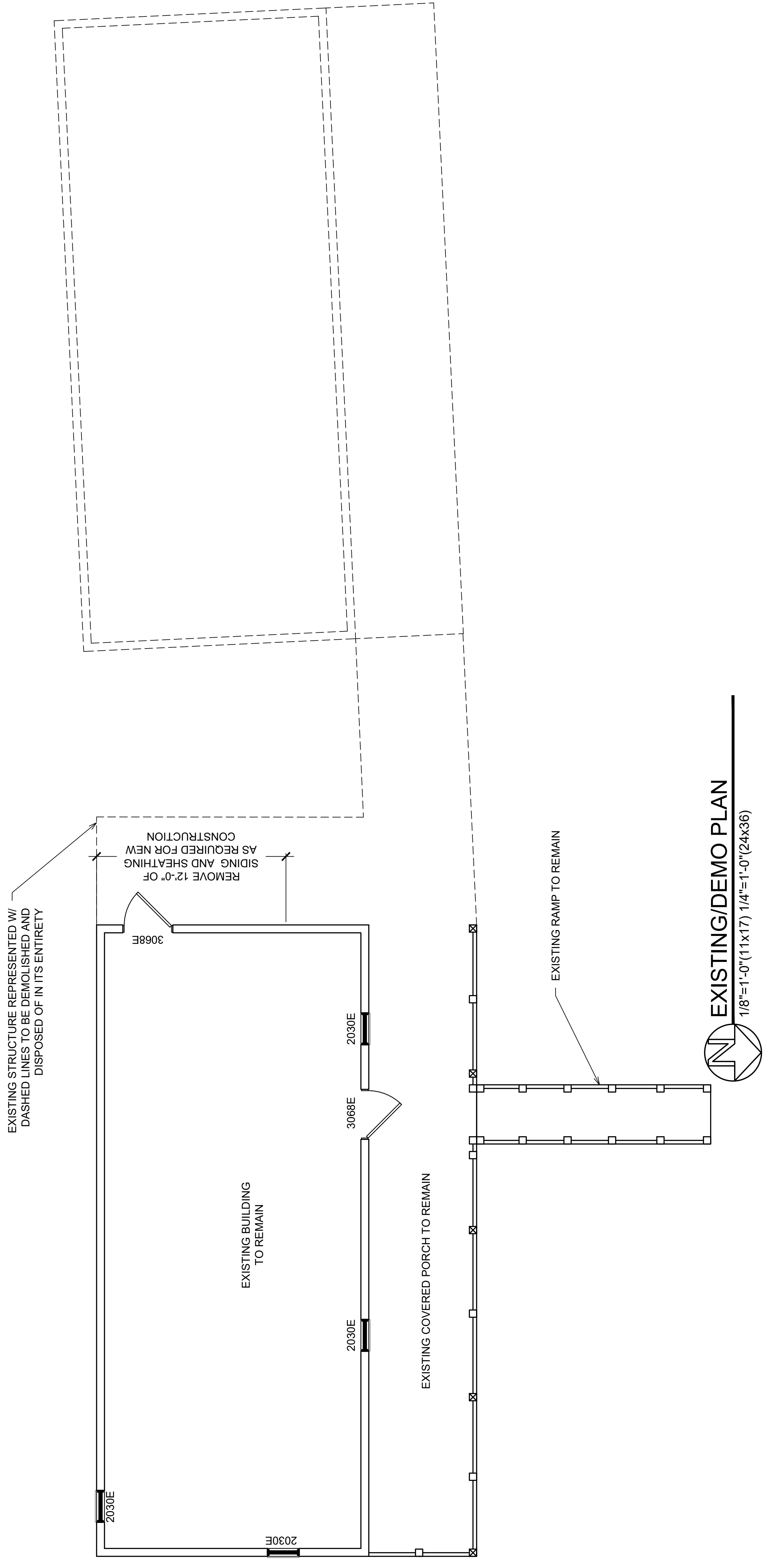



REVISONS:	COMMENTS:	DATE:

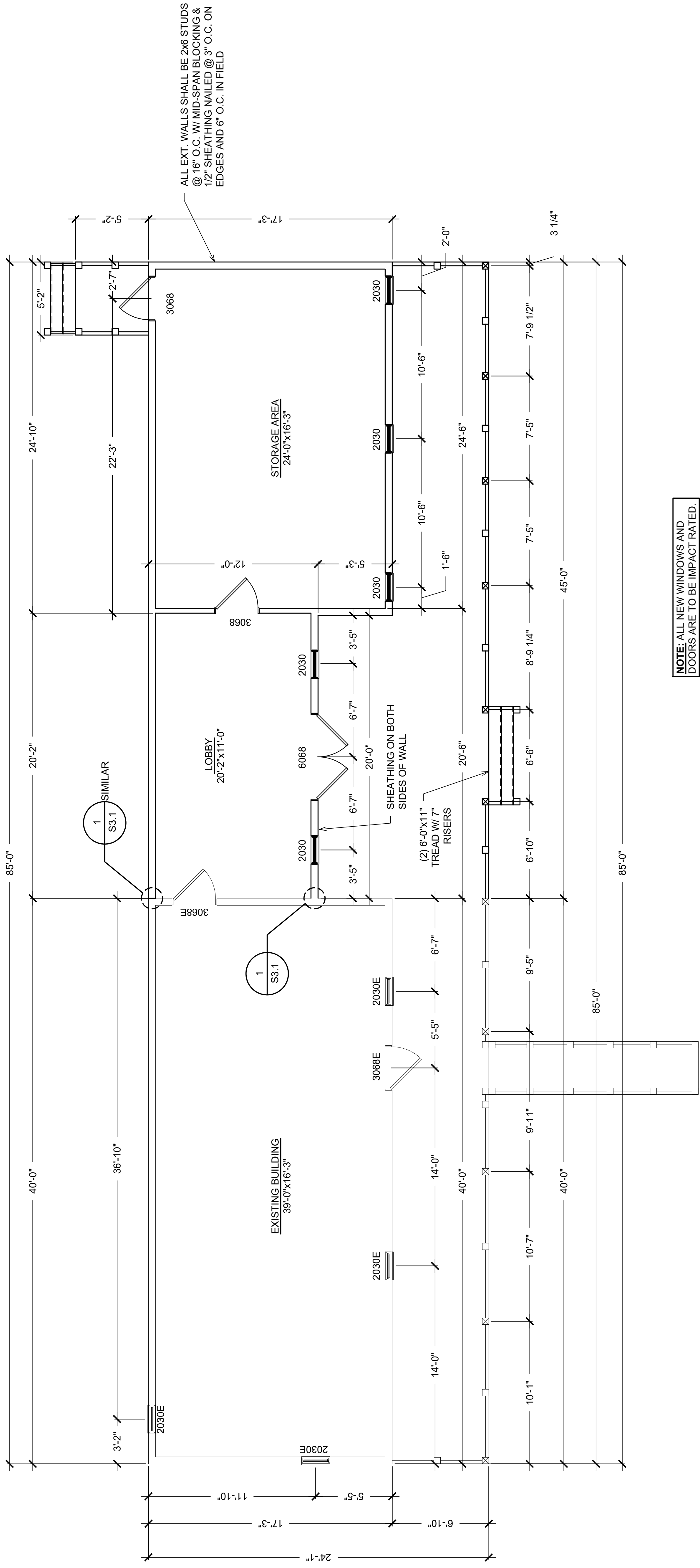

**PROPOSED ADDITION PLAN**  
1/8"=1'-0"(11x17) 1/4"=1'-0"(24x36)

REVISIONS:	COMMENTS:	DATE:

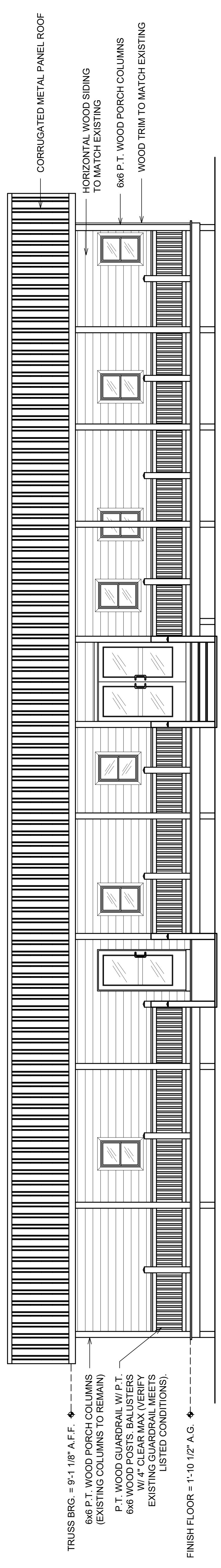

**1 FRONT ELEVATION**  
1/8"=1'-0" (11x17) 1/4"=1'-0" (24x36)

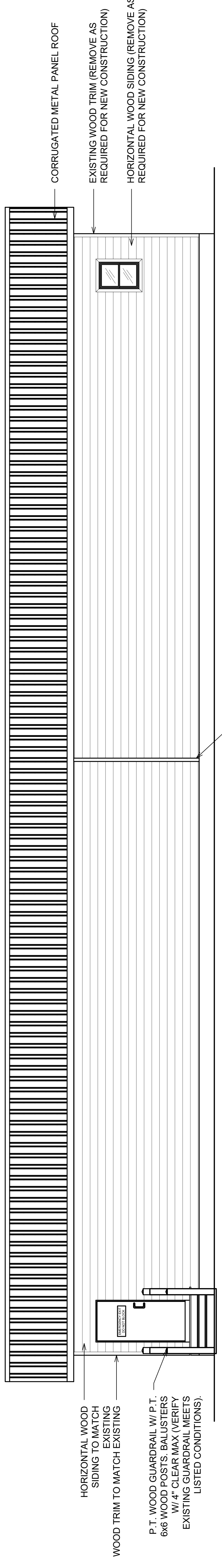

**2 REAR ELEVATION**  
1/8"=1'-0" (11x17) 1/4"=1'-0" (24x36)

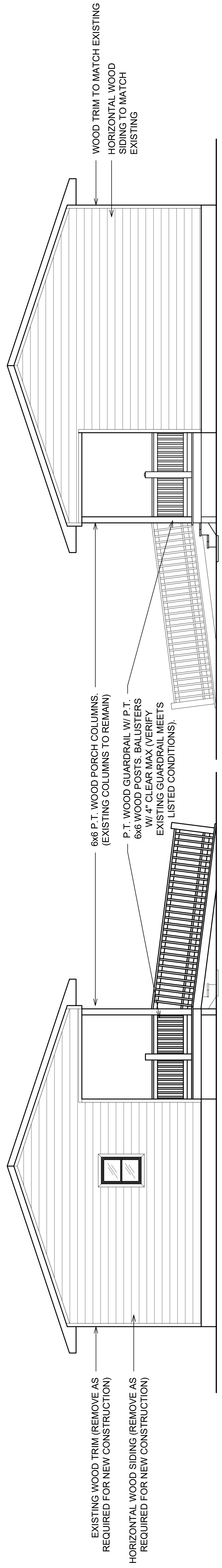

**3 RIGHT SIDE ELEVATION**  
1/8"=1'-0" (11x17) 1/4"=1'-0" (24x36)

**4 LEFT SIDE ELEVATION**  
1/8"=1'-0" (11x17) 1/4"=1'-0" (24x36)



**STRUCTURAL NOTES**

**GENERAL**

- DESIGN CODE DATA  
2015 INTERNATIONAL BUILDING CODE  
2017 FLORIDA STATE BUILDING CODE  
ASCE 7-10: MINIMUM DESIGN LOADS FOR BUILDINGS AND OTHER STRUCTURES  
ASCE 7-10: WINDING CODE REQUIREMENTS FOR STRUCTURAL CONCRETE AND MASONRY
- ANSI/AIA R9-2005: NATIONAL DESIGN SPECIFICATION FOR WOOD STRUCTURES  
ACI 318-08/ACI 308-11: BUILDING CODE REQUIREMENTS AND SPECIFICATION FOR MASONRY STRUCTURES
- BUILDING OCCUPANCY CATEGORY= II (PER ASCE 7-10: TABLE 1-1).
- DESIGN LOADS:

- DEAD LOADS:  
• ROOF = 20 PSF
- LIVE LOADS:  
• ROOF = 20 PSF  
• FLOOR - 1ST STORY = 30 PSF
- WIND DESIGN CRITERIA  
WIND SPEED = 140 MPH  
EXPOSURE = C  
ENCLOSURE CLASSIFICATION = ENCLOSED  
Kz= 1.0  
Kzt= 1.0  
BASE VELOCITY PRESSURE, Q=38.4 PSF

COMPONENTS AND CLADDING		DESIGN PRESSURE (KSD)	
TRIBUTARY AREA (DSF)	DESIGN PRESSURE (PSF)	POSITIVE (PSF)	NEGATIVE (PSF)
ROOF			
ZONE 1	26.2	15.7	24.9
ZONE 2	26.2	15.7	24.9
ZONE 3	26.2	15.7	24.9
TRIBUTARY AREA (WSF)			
ZONE 1	18.5	31.7	11.1
ZONE 2	18.5	31.7	11.1
ZONE 3	18.5	31.7	11.1
WALLS			
TRIBUTARY AREA (DSF)			
ZONE 1	46.4	69.3	27.2
ZONE 2	46.4	69.3	27.2
TRIBUTARY AREA (WSF)			
ZONE 4	38.6	42.4	23.2
ZONE 5	38.6	42.4	23.2

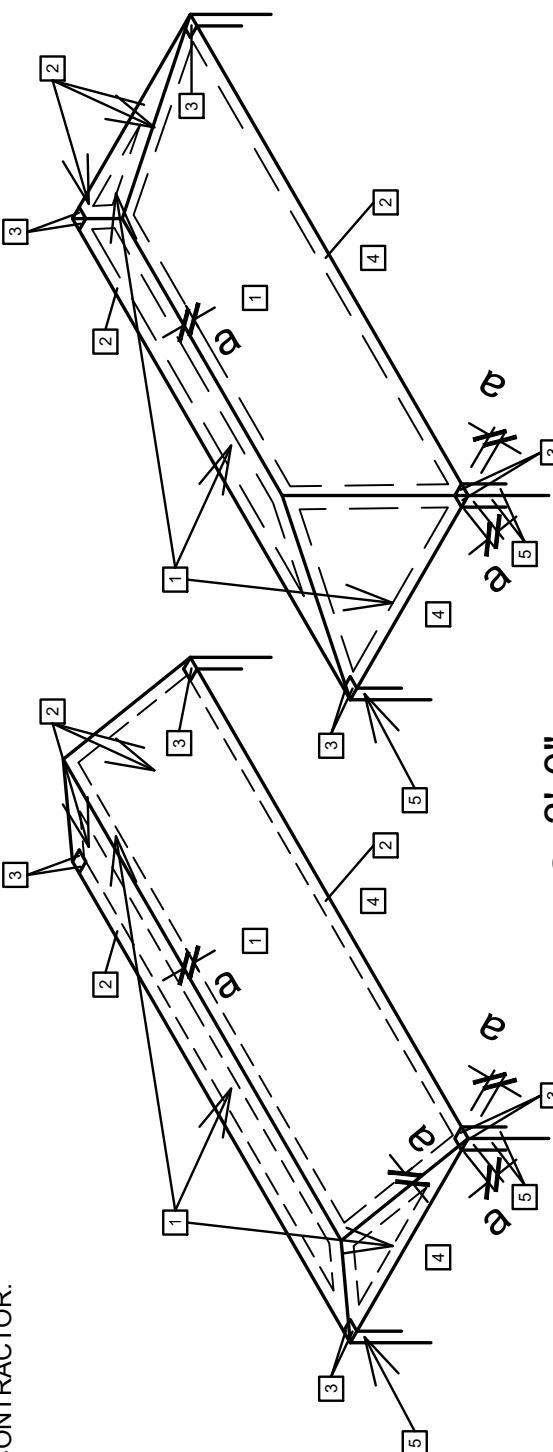

**GABLE ROOF WIND ZONE DIAGRAM**

**HIP ROOF WIND ZONE DIAGRAM**

**MATERIAL SPECIFICATIONS**

- CONCRETE**  
FOOTINGS AND FOUNDATION WALLS  
ALL OTHER CIP CONCRETE NOT NOTED  
CONCRETE REINFORCING STEEL  
WELDED WIRE REINFORCEMENT  
ANCHOR RODS
- ADHESIVE ANCHORS**  
MECHANICAL ANCHORS  
POWDER DRIVEN FASTENERS
- MASONRY**  
CONCRETE MASONRY UNITS  
WEIGHT UNITS  
1,800 PSI, ASTM C270  
MORTAR TYPE S- BELOW GRADE  
MASONRY GROUT, ASTM C76  
MASONRY REINFORCING STEEL  
JOINT REINFORCEMENT
- WOOD**  
2x6 AND SMALLER  
MINIMUM DESIGN VALUES  
Fb 975 PSI  
Ft 450 PSI  
Fv 135 PSI  
Fc-A 425 PSI  
Fc-B 1,150 PSI  
E 1,400,000 PSI  
Emm 310,000 PSI
- 2x8 AND LARGER**  
MINIMUM DESIGN VALUES  
Fb 1,000 PSI  
Ft 575 PSI  
Fv 135 PSI  
Fc-A 465 PSI  
Fc-B 1,450 PSI  
E 1,300,000 PSI  
Emm 470,000 PSI
- HEM-FIR NO. 2 OR BETTER**
- PARALLAM PLUS (PSL PLUS)**  
MINIMUM DESIGN VALUES  
Fb= 2,200 PSI  
E= 2,400,000 PSI

**CONCRETE CONSTRUCTION**

- ALL CONCRETE DESIGN AND CONSTRUCTION SHALL CONFORM WITH THE LOCAL BUILDING CODE REQUIREMENTS AND THOSE OF THE LATEST EDITION OF THE FOLLOWING STANDARDS: ACI 318, ACI 308, ACI 301, AND ACI 307.
- ALL CONCRETE, UNLESS SPECIFICALLY NOTED, SHALL BE NORMAL WEIGHT (145 PCF).
- THE COMPRESSIVE STRENGTH OF ALL GROUT USED TO PROVIDE LEVEL BEARINGS OF COLUMN BASE PLATES SHALL MEET OR EXCEED THE COMPRESSIVE STRENGTH OF THE SUPPORTING CONCRETE MEMBER.
- CONCRETE REINFORCING SHALL HAVE THE FOLLOWING MINIMUM PROTECTIVE COVER:  
CONCRETE CAST AGAINST EARTH = 3"  
#8 THROUGH #18 BARS = 2"  
#4 THROUGH #7 BARS = 1"  
CONCRETE WITH INTERIOR EXPOSURE:  
SLABS, WALLS, JOISTS  
#14 AND #18 BARS = 1-1/2"  
#11 BAR AND SMALLER = 3/4"
- UNLESS NOTED OTHERWISE ON THE DRAWINGS ALL REINFORCING SHALL BE LAPPED TO DEVELOP ITS CAPACITY AS FOLLOWS: (SEE TABLE FOLLOWING THIS SECTION)
- SLAB-ON-GRADE SHALL HAVE CLASS "A" TOLERANCE.
- A 6 MIL (MIN) POLYETHYLENE VAPOR BARRIER WITH JOINTS LAPPED NOT LESS THAN 6" SHALL BE PLACED BETWEEN THE SAND BASE AND THE CONCRETE FLOOR.
- CALCIUM CHLORIDE AND/OR ADMIXTURES CONTAINING CALCIUM CHLORIDE SHALL NOT BE USED.
- PLACING OF CONCRETE SHALL BE DONE IN CONFORMANCE WITH ACI-308 FOR COLD WEATHER AND ACI-305 FOR HOT WEATHER.

BAR SIZES	STANDARD	TOP BAR	SPICE	HOOK
#3	13"	16"	16"	6"
#4	20"	24"	24"	6"
#5	26"	44"	44"	10"
#6	36"	52"	52"	12"
#7	52"	52"	52"	14"

- MULTIPLY LAP LENGTHS BY 1.3 FOR TOP BAR CONDITIONS. TOP BARS ARE HORIZONTAL BARS WITH 12 INCHES OR MORE OF CONCRETE BELOW.
- FOUNDATION**
- ALLOWABLE SOIL BEARING CAPACITY = 2,000 PSF FOR STRIP FOOTINGS (PRESUMPTIVE)
  - GRADE AREAS IN ACCORDANCE WITH ELEVATIONS AND GRADES SHOWN ON THE SITE DRAWINGS AND AS REQUIRED FOR DRAINAGE.
  - ALL SLAB ON GRADE AREAS SHALL BE PROOF ROLLED. ALL SOFT SPOTS SHALL BE REMOVED AND REPLACED WITH COMPACTABLE FILL.
  - SLAB ON GRADE TO BE CONSTRUCTED ON A MINIMUM OF 6" OF COMPACTED GRANULAR FILL.
  - ALL FILL MATERIAL USED IN GRADING OPERATIONS SHALL CONSIST OF EARTH, WHICH IS FREE OF DEBRIS, BOULDERS OR ORGANIC MATERIAL. FILL SHALL BE PLACED IN MAXIMUM OF 12" LIFTS AND COMPACTED TO 98% OF MODIFIED PROCTOR MAXIMUM DRY DENSITY. INDICATED ABOVE.
  - ALL FOOTINGS SHALL BEAR ON UNDISTURBED SOIL OR COMPACTED FILL HAVING A MINIMUM ALLOWABLE BEARING CAPACITY AS INDICATED ABOVE.
  - THE ENGINEER SHALL BE NOTIFIED IF ACTUAL FIELD CONDITIONS DO NOT MEET BEARING REQUIREMENTS OR, IF QUESTIONABLE SOIL CONDITIONS ARE DISCOVERED INCLUDING BUT NOT LIMITED TO PEAT AND OTHER HIGH ORGANIC SOILS.
  - ANY FOUNDATION UNDER THE BASE FLOOD ELEVATION SHALL COMPLY WITH R322.2.2 OF THE FLORIDA BUILDING CODE & WILL PROVIDE FLOOD VENTS TO MEET THESE REQUIREMENTS.

**WOOD CONSTRUCTION**

- DIMENSION LUMBER**
- ALL DIMENSIONAL LUMBER NOMINAL 2" THICK AND 4-8" WIDE SHALL BE #2 SPF OR EQUAL. WIDTHS 10" AND WIDER SHALL BE #2 HEM-FIR.
  - LAMINATED VENEER LUMBER (LVL) TO BE 2x6 AND Fb = 3100 PSI OR GREATER.
  - ALL LEVEL 1 STRUCTURAL WALL FRAMING TO BE NOMINAL 2x ENGINEERED LAMINATED VENEER LUMBER (LVL) (BOISE VERSA - STUD 17/6590 OR APPROVED EQUAL).
  - SILLS AND MEMBERS EXPOSED DIRECTLY TO MOISTURE OR IN DIRECT CONTACT WITH CONCRETE OR MASONRY SHALL BE PRESSURE TREATED.
  - PLYWOOD SHALL CONFORM TO THE LATEST EDITION OF U.S. PRODUCT STANDARD PS-1. INSTALL IN STAGGERED PATTERN. NAILS AS REQUIRED FOR DIAPHRAGM ACTION.
  - SHEAR PLATE AND SPLIT RING FASTENERS SHALL BE TECO OR APPROVED EQUAL.
  - NAILS SHALL BE STRONGHOLD. GALVANIZED COMMON NAILS OF THE SIZES INDICATED, EXCEPT THAT STAINLESS STEEL SIDING NAILS SHALL BE USED FOR THE ATTACHMENT OF EXTERIOR PLYWOOD SIDING.
  - ALL BOLTS AND LAG SCREWS SHALL BE AMERICAN STANDARD MANUFACTURE.
  - BOLT HOLES IN WOOD SHALL BE DRILLED 1/16" MAXIMUM OVERSIZE. HOLES FOR SCREWS AND LAG SCREWS SHALL BE FIRST BORED FOR THE SAME DEPTH AND DIAMETER OF THE SHANK, THEN THE REMAINDER OCCUPIED BY THE SCREW OR LAG SCREW. THE SCREW OR LAG SCREW SHALL BE DRILLED TO A DIAMETER LARGER THAN THE ROOT OF THE THREAD. ALL SCREWS SHALL BE SPOILED, NOT DRIVEN TO PLACE.
  - PROVIDE WASHERS UNDER ALL NUTS AND HEADS OF BOLTS AND LAG SCREWS. WASHERS SHALL BE EITHER ROUND MALLEABLE IRON OR SQUARE CUT STEEL WASHERS 1/4" THICK X 3 FASTENER DIAMETERS.
  - WHEREVER NECESSARY TO CUT OR DRILL TREATED LUMBER, TREAT THE CUT OR BORED SURFACES WITH TWO HEAVY COATS OF THE SAME PRESERVATIVE AS USED IN THE ORIGINAL TREATMENT.
  - PROVIDE SOLID BLOCKING AT MID-SPAN OF ALL SAWN JOISTS AND STUDS EXCEEDING 10 FOOT SPAN AND AT 10 FOOT MAXIMUM ON CENTER.
  - MEMBERS BEARING ON CONCRETE OR MASONRY WALLS SHALL HAVE A 1/2" AIR SPACE AROUND SIDES AND END OF BEAM.
  - DESIGN FABRICATION AND CONSTRUCTION SHALL CONFORM TO THE "NATIONAL DESIGN SPECIFICATION FOR WOOD CONSTRUCTION" CURRENT EDITION AS RECOMMENDED BY THE NATIONAL LUMBER MANUFACTURERS ASSOCIATION.
  - ALL COLUMNS SHOWN ON STRUCTURAL DRAWINGS SHALL BE CONTINUOUS UNLESS NOTED.
  - SET ALL JOISTS WITH GROWN UP.
  - WALL SHEATHING SHALL BE NAILED AS INDICATED ON DRAWINGS. ALL PANEL EDGES SHALL BE BACKED WITH 2x OR WIDER FRAMING.
  - PLYWOOD SHEATHING TO BE GRADED APA STRUCTURAL I.
  - ALL BOLTS, LAG SCREWS, SCREWS AND NAILS SHALL HAVE A HOT DIP GALVANIZED FINISH AT MINIMUM. ALL EXPOSED HARDWARE IS RECOMMENDED BE 316 STAINLESS STEEL.
  - WURSON STRONGS THE CONNECTORS ARE SPECIFICALLY REQUIRED TO MEET THE STRUCTURAL CALCULATIONS OF PLAN. BEFORE SUBSTITUTING ANOTHER BRAND, CONFIRM LOAD CAPACITY BASED ON RELIABLE PUBLISHED TESTING DATA OR CALCULATIONS. THE ENGINEER OF RECORD IS REQUIRED TO EVALUATE AND GIVE WRITTEN APPROVAL FOR SUBSTITUTION PRIOR TO INSTALLATION.
  - COLUMNS AND JOISTS STAINLESS STEEL CONNECTORS SHALL BE USED FOR THE ATTACHMENT OF EXTERIOR BEAMS. ALL SIMPSON Z-MAX STAINLESS STEEL CONNECTORS SHALL BE USED FOR THE ATTACHMENT OF EXTERIOR BEAMS. ALL EXPOSED HARDWARE IS RECOMMENDED BE 316 STAINLESS STEEL.

**VERTICAL STRUCTURAL PANEL SHEATHING NOTES (WOOD FRAMING)**

- FASTENERS SHALL NOT BE LOCATED LESS THAN 3/8" FROM THE EDGE OF THE PANEL.
  - FASTENERS SHALL BE DRIVEN FLUSH WITH SURFACE OF SHEATHING.
  - FASTENERS SHALL BE OF SUFFICIENT LENGTH TO ENSURE PENETRATION INTO FRAMING MEMBERS BY AT LEAST 1 1/2".
  - FRAMING MEMBERS SHALL BE A MINIMUM 2" NOMINAL IN THE DIMENSION TO WHICH THE STRUCTURAL PANEL IS ATTACHED. (U.N.O.)
  - NO UNBLOCKED PANELS LESS THAN 1'-0" WIDE SHALL BE USED.
  - PANEL EDGES SHALL BUTT ALONG THE CENTERLINE OF FRAMING MEMBERS.
- WOOD SHEATHING (WALLS)**
- BACK ALL SHEATHING PANEL EDGES WITH MINIMUM, NOMINAL 2 X BLOCKING.
  - 1/2" APA EXPOSURE I, RATED SHEATHING WITH 32/16 SPAN RATING (U.N.O.)
  - FRAMING TO BE MAXIMUM 1'-4" O.C.
  - FASTENERS SHALL BE A MINIMUM 8d COMMON (131° Ø) OR GALVANIZED BOX NAILS (Ø.113" Ø) GALVANIZED NAILS SHALL BE HOT DIPPED OR TUMBLED.
  - OFFSET PANEL JOINTS ON EACH SIDE OF WALL. MINIMUM ONE STUD BAY.
  - PANELS MAY BE INSTALLED EITHER HORIZONTALLY OR VERTICALLY.
  - WALL SHEATHING SPACE NAILS @ 6" O.C. ALONG INTERMEDIATE FRAMING MEMBERS. (FIELD OF PANEL) SPACE NAILS @ 3" O.C. AT ALL PANEL EDGES.
  - EACH PANEL SHALL BE IDENTIFIED WITH THE GRADE TRADEMARK OF THE AMERICAN PLYWOOD ASSOCIATION AND SHALL MEET THE REQUIREMENTS OF PRODUCT STANDARD (PS), APPLICATION AND NAILING OF PLYWOOD SHALL BE IN ACCORDANCE WITH THE RECOMMENDATIONS OF THE AMERICAN PLYWOOD ASSOCIATION AND TABLE 2304.9.1 "FASTENING SCHEDULE" OF THE INTERNATIONAL BUILDING CODE UNLESS OTHER REQUIREMENTS NOTED ON THE PLAN ARE MORE STRICT.



3000 W. 29th Street  
Palm Bay, FL 32909  
mwebber.com  
Michael K. Weber P.E.  
FL P.E. #475798

REVISIONS	COMMENTS	DATE

RENOVATIONS FOR:  
CALLAWAY HISTORIC SOCIETY  
522 BEULAH AVE.  
CALLAWAY, FLORIDA

**STRUCTURAL NOTES**

12/4/2019  
Project No: 18330  
Drawn By: JCC  
Checked By: MKV

Drawing Number  
**\$1.0**

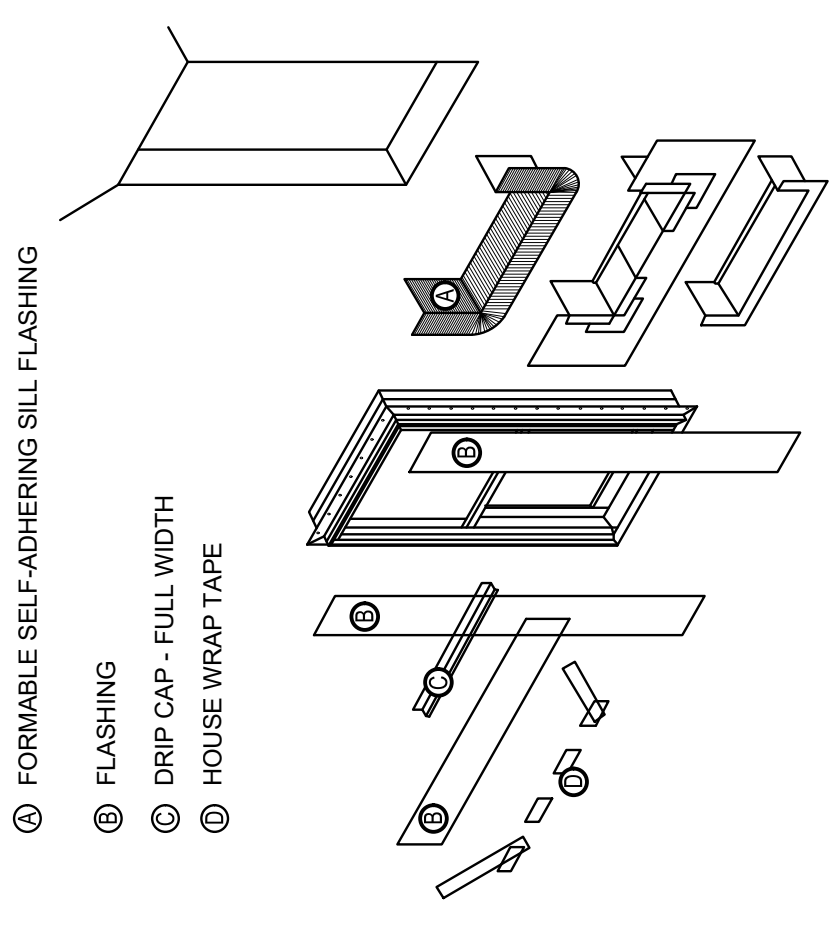

**WINDOW FLASHING DETAILS**

Opening Size	Header Size	No. of LAMB Studs	No. of Jack Studs	No. of Beam Studs	No. of Hold Down Studs	Opening Hold Down
8"	3-2x12	2	2	2	2	HOLD-SDB25
7"	2-2x12	2	2	2	2	HOLD-SDB25
6"	2-2x10	2	1	1	1	HOLD-SDB25
4"	2-2x10	1	1	1	1	HOLD-SDB25
3"	2-2x10	1	1	1	1	HOLD-SDB25

- NOTE: ALL BEAMS TO BE FLITCHED WITH 7/16" PLYWOOD MINIMUM. NAIL WITH 16D NAILS STAGGERED 6" O.C.  
PROVIDE 5/8" DIA. THREADED ROD SYSTEM @ 6'-0" O.C. & WITHIN 12" OF CORNERS & EACH SIDE OF OPENING.  
USE 4"x4" x1/8" WASHERS AT TOP PLATE OF 2x6 WALL FRAMING & 3"x3"x1/8" WASHERS AT TOP PLATE OF 2x4 WALL FRAMING. PROVIDE 5/8" X8" 1-BOLT ANCHORS @ 2'-0" O.C. FOR ALL LOAD BEARING WALLS.





**WEBER**  
structural engineering  
3000 W. 29th Street  
Panama City, FL 32405  
mweber.com

Michael K. Weber P.E.  
FL P.E. #75798

REVISIONS	COMMENTS	DATE

RENNOVATIONS FOR:  
CALLAWAY HISTORIC SOCIETY  
522 BEULAH AVE.  
CALLAWAY, FLORIDA

FLOOR FRAMING

12/4/2019

Project No: 18330  
Drawn By: JCC  
Checked By: MKW

Drawing Number  
**S2.0**

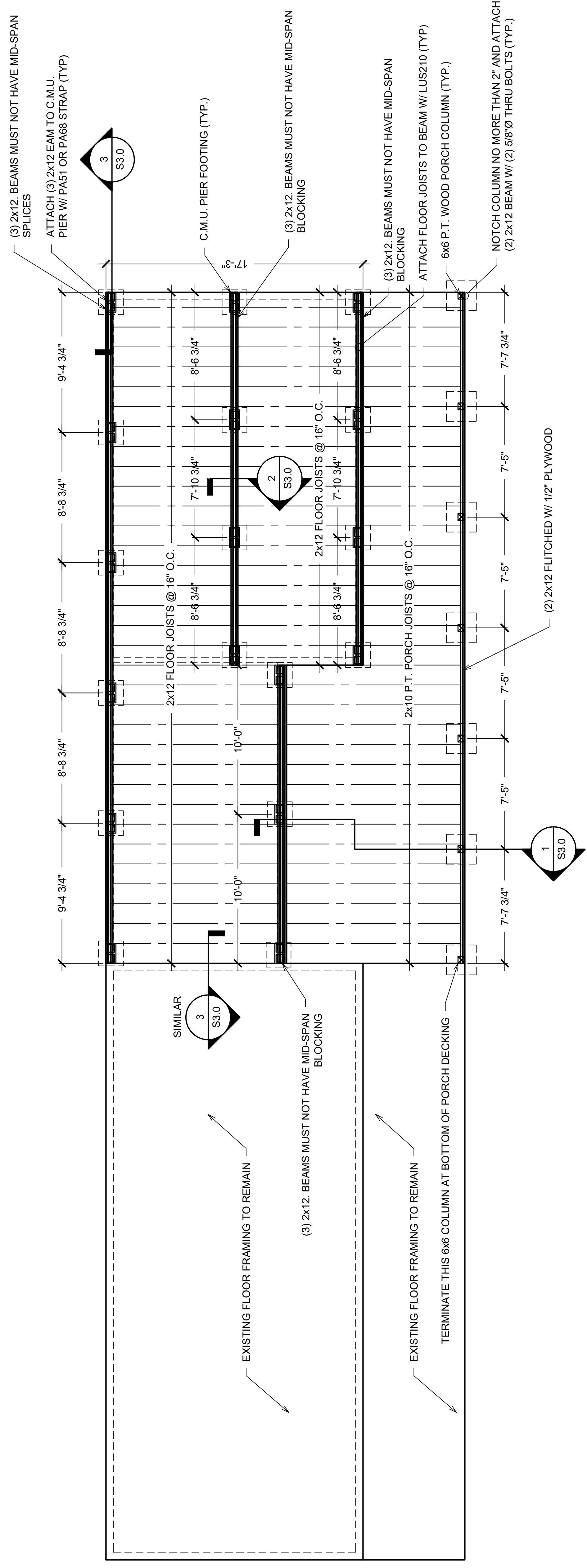

**1 FLOOR FRAMING PLAN**  
1/8"=1'-0"(11x17) 1/4"=1'-0"(24x36)

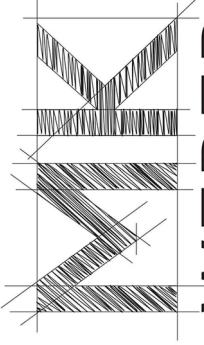

**WEBER**  
structural engineering

3000 W. 23rd Street  
Panama City, FL 32405  
mkwebber.com

Michael K. Weber, P.E.  
FL P.E. #75798

REVISIONS:	COMMENTS:	DATE:

RENOVATIONS FOR:  
CALLAWAY HISTORIC SOCIETY  
522 BEULAH AVE.  
CALLAWAY, FLORIDA

ROOF PLAN

12/4/2019

Project No.: 19330  
Drawn By: JCC  
Checked By: MKW

Drawing Number  
**S2.1**

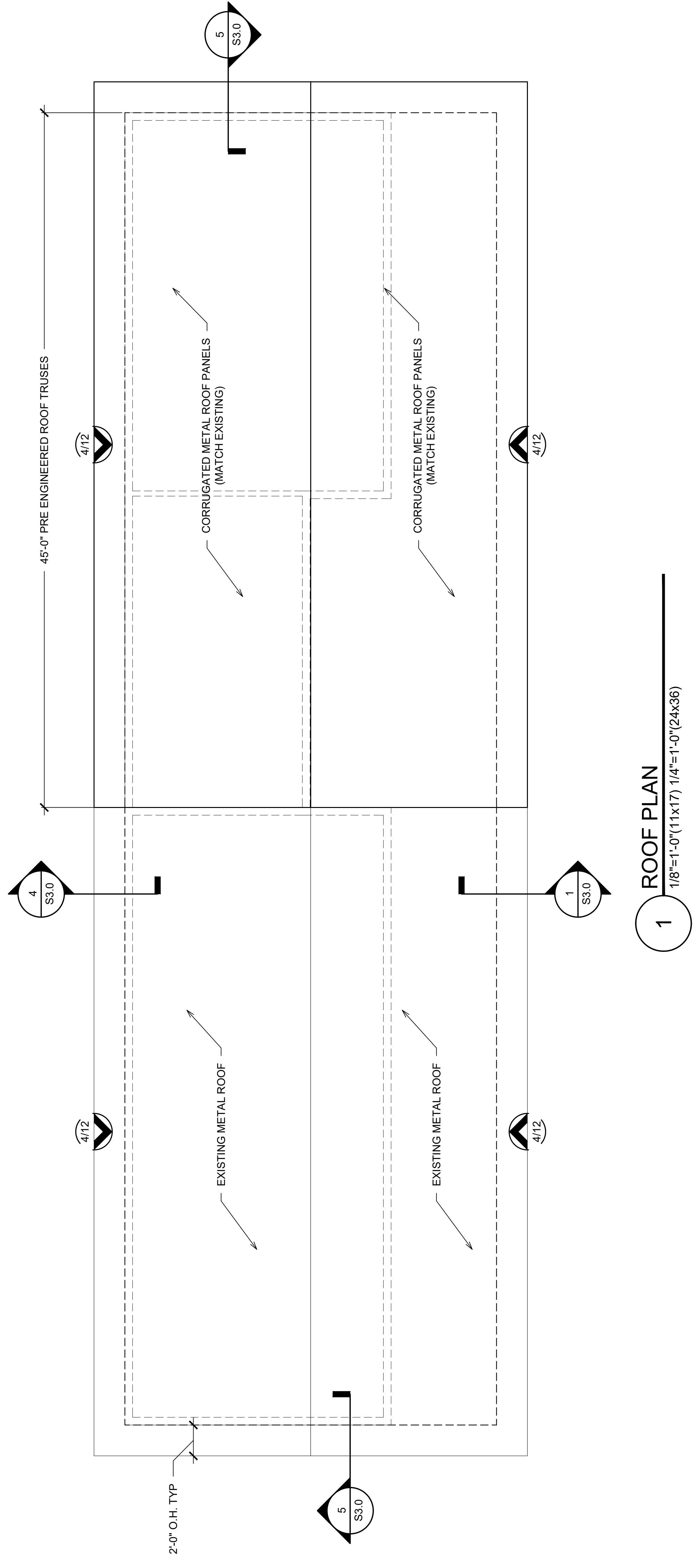



REVISIONS	COMMENTS	DATE

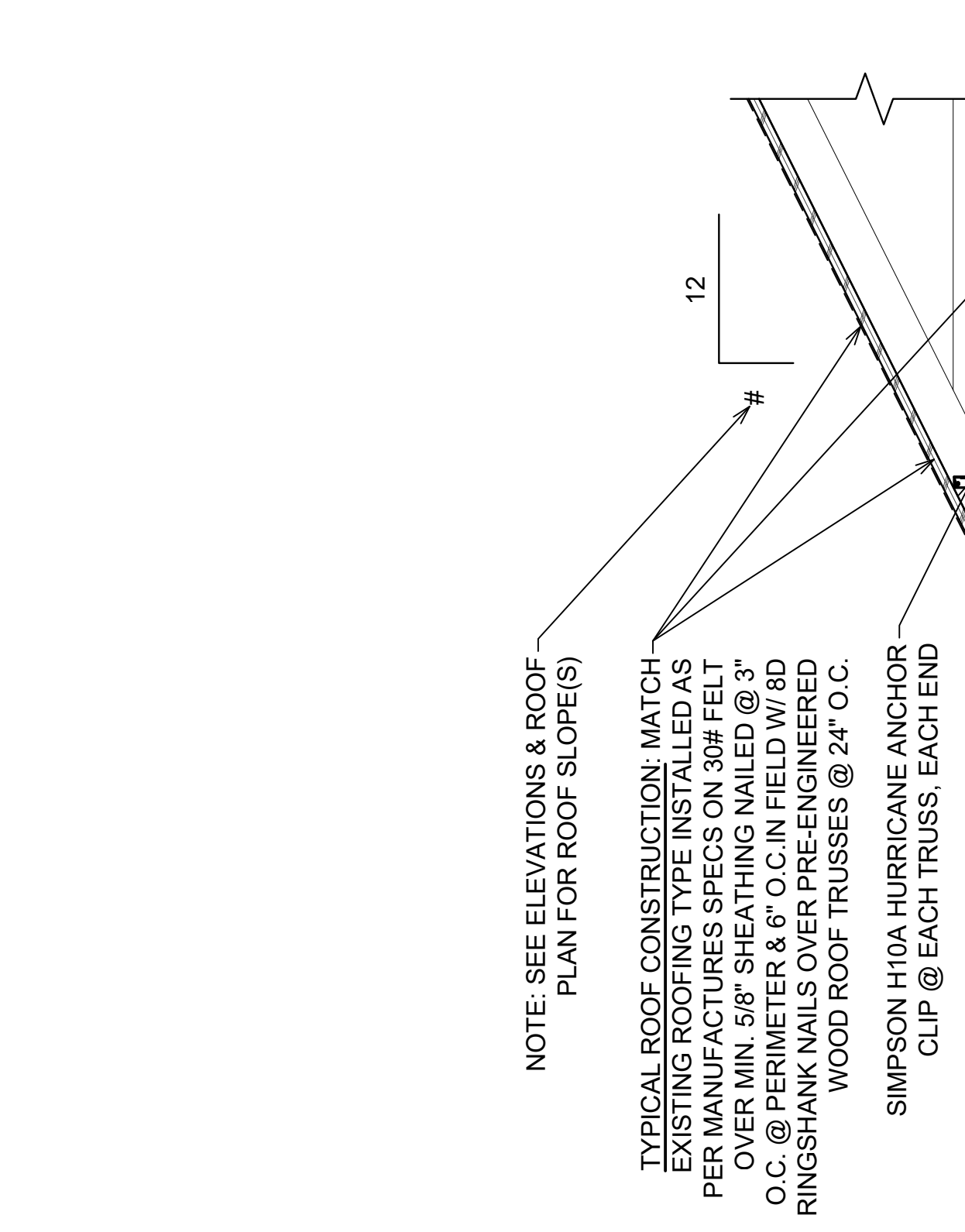
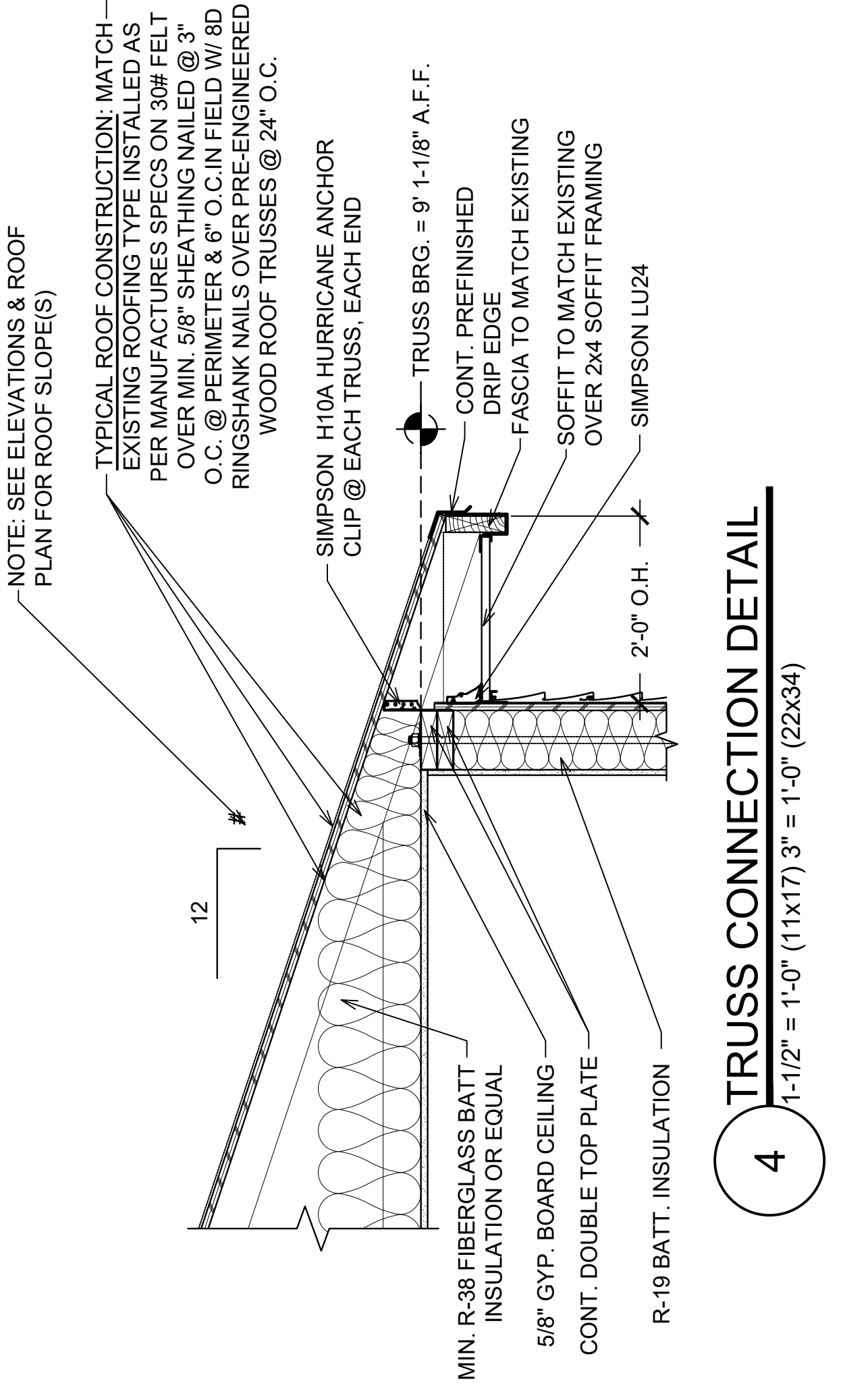
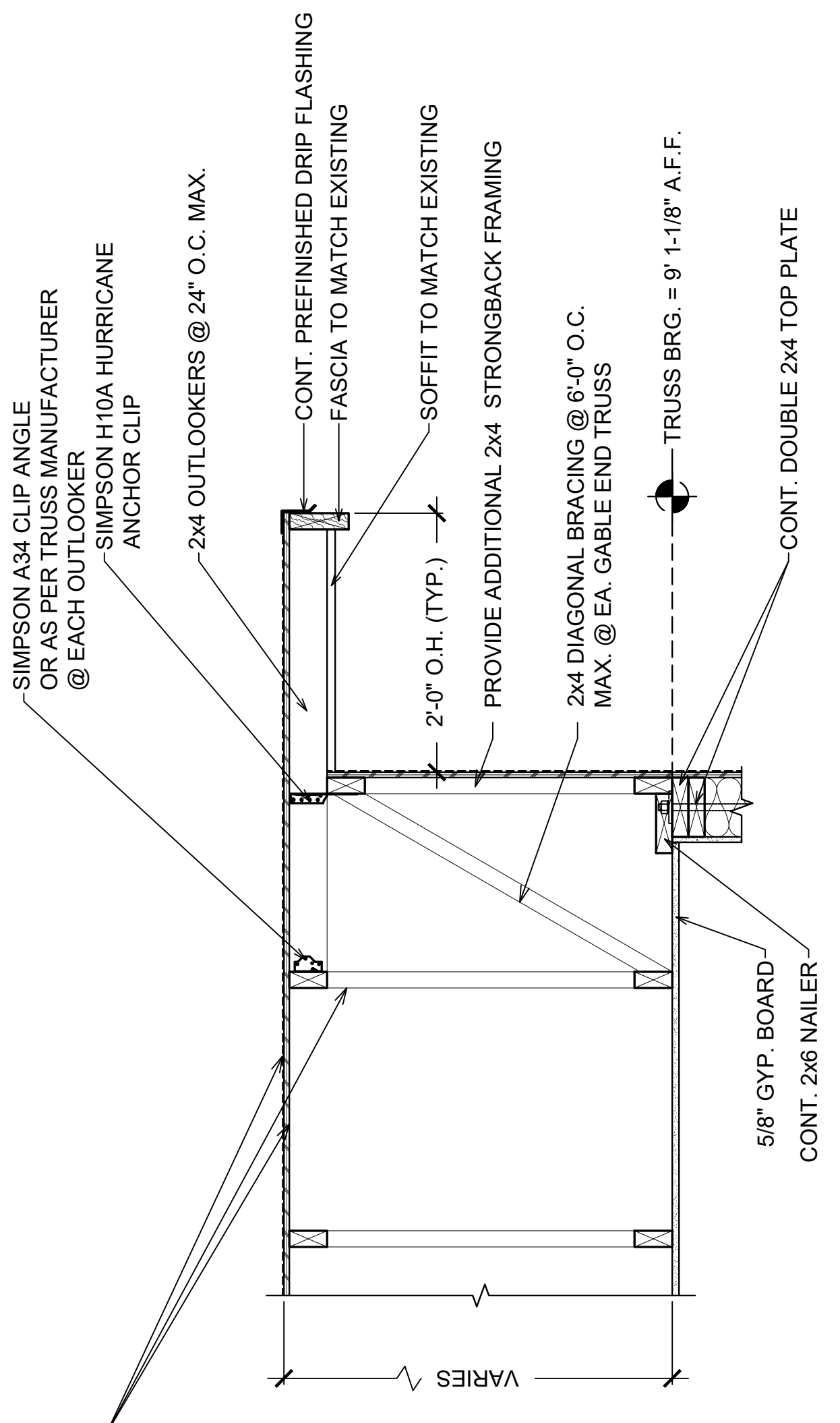

**5 GABLE ENDWALL DETAIL**  
1'-1/2" = 1'-0" (11x17) 3" = 1'-0" (22x34)

**4 TRUSS CONNECTION DETAIL**  
1'-1/2" = 1'-0" (11x17) 3" = 1'-0" (22x34)

**1 PORCH CONNECTION DETAIL**  
1'-1/2" = 1'-0" (11x17) 3" = 1'-0" (22x34)

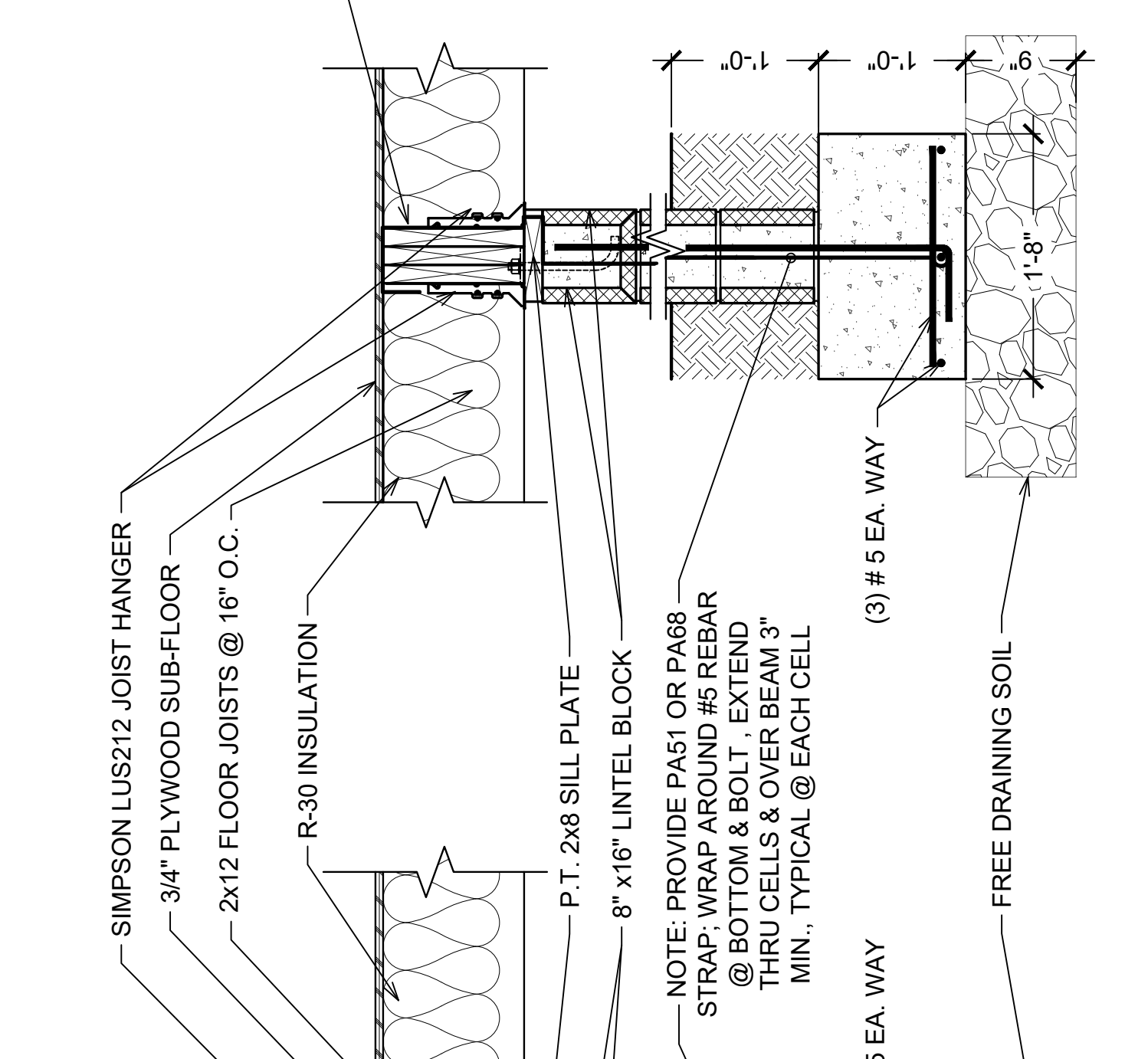
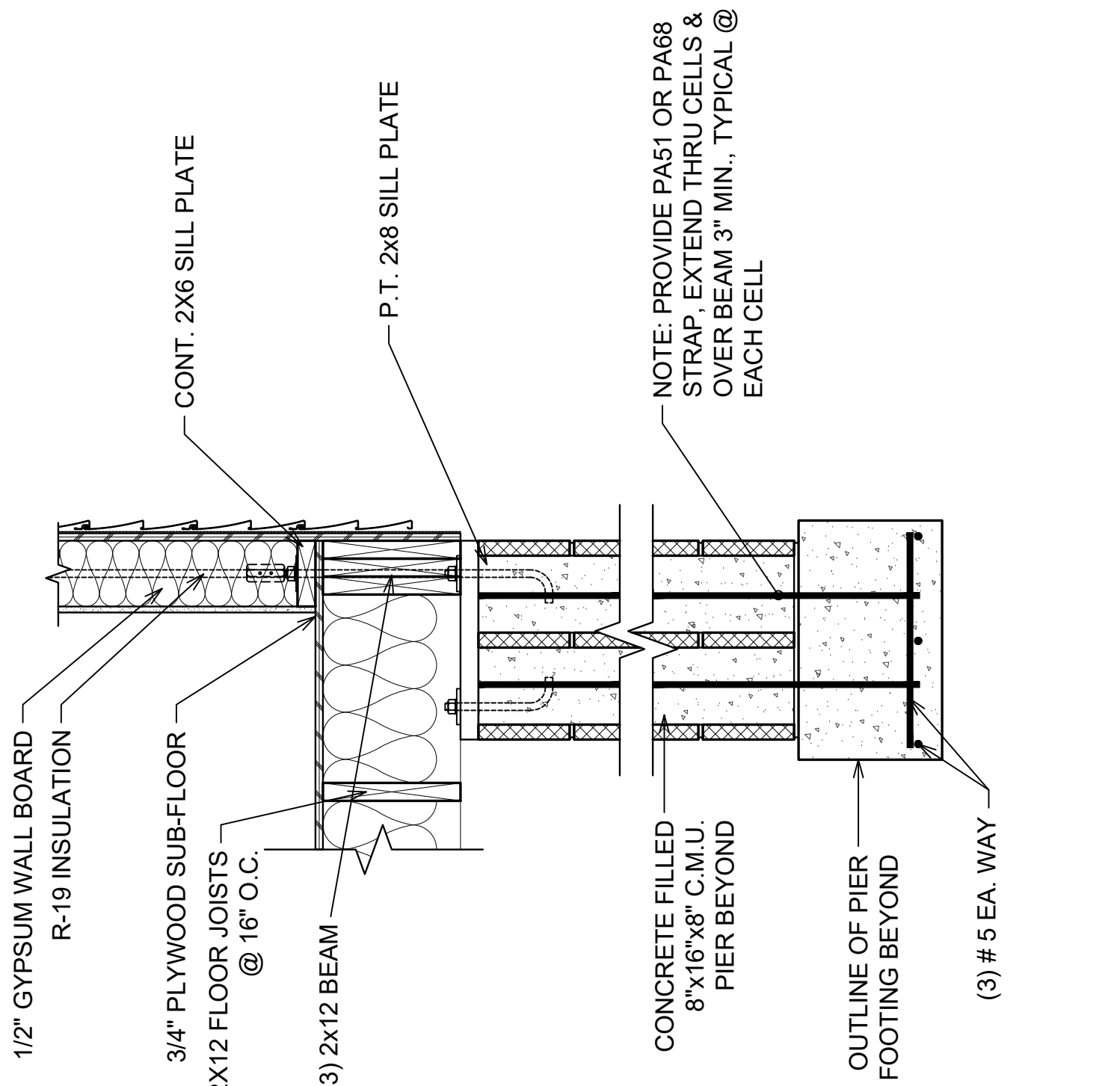

**2 GIRDER BEAM DETAIL**  
1'-1/2" = 1'-0" (11x17) 3" = 1'-0" (22x34)

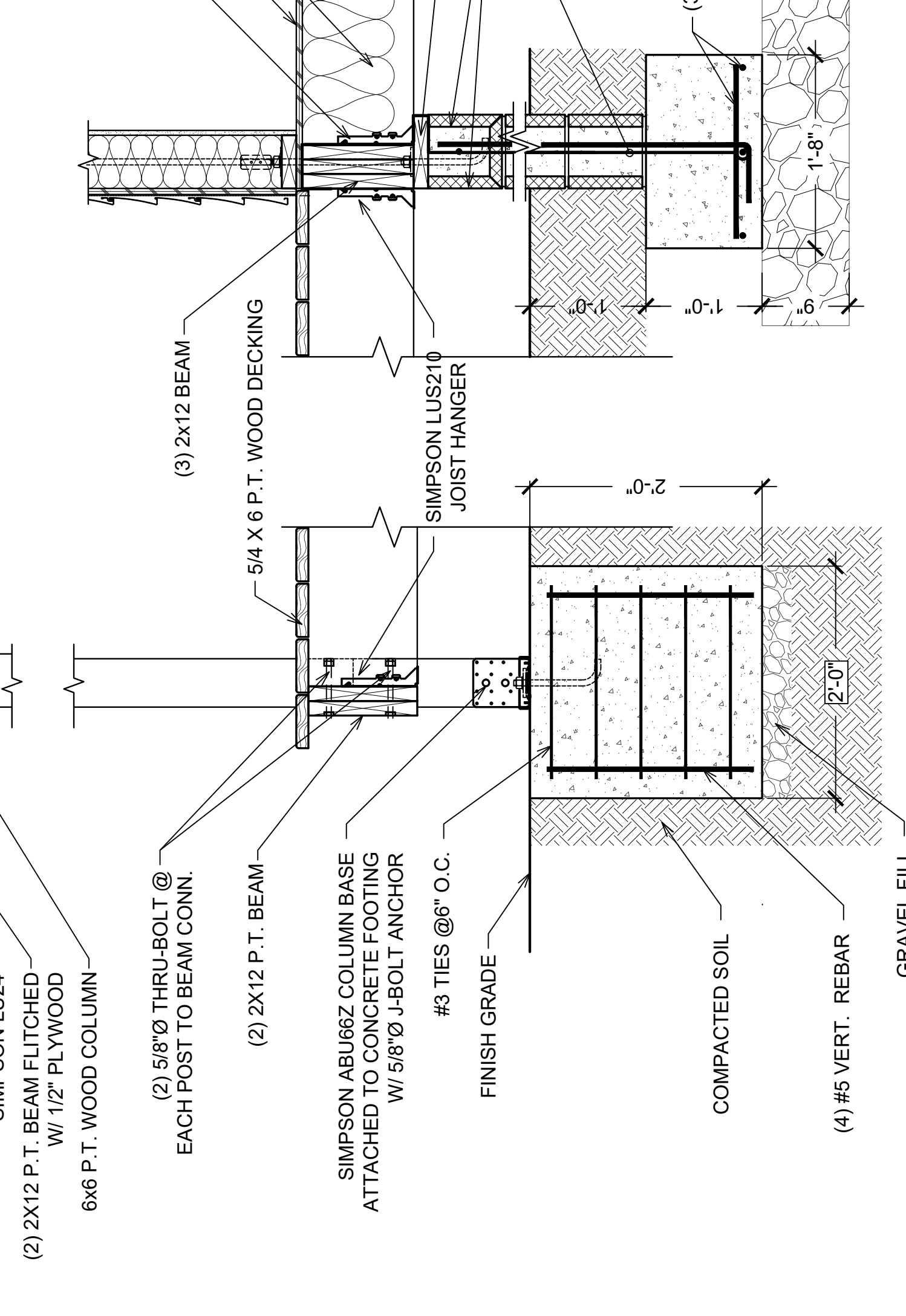

**3 TYP. WALL DETAIL**  
1'-1/2" = 1'-0" (11x17) 3" = 1'-0" (22x34)



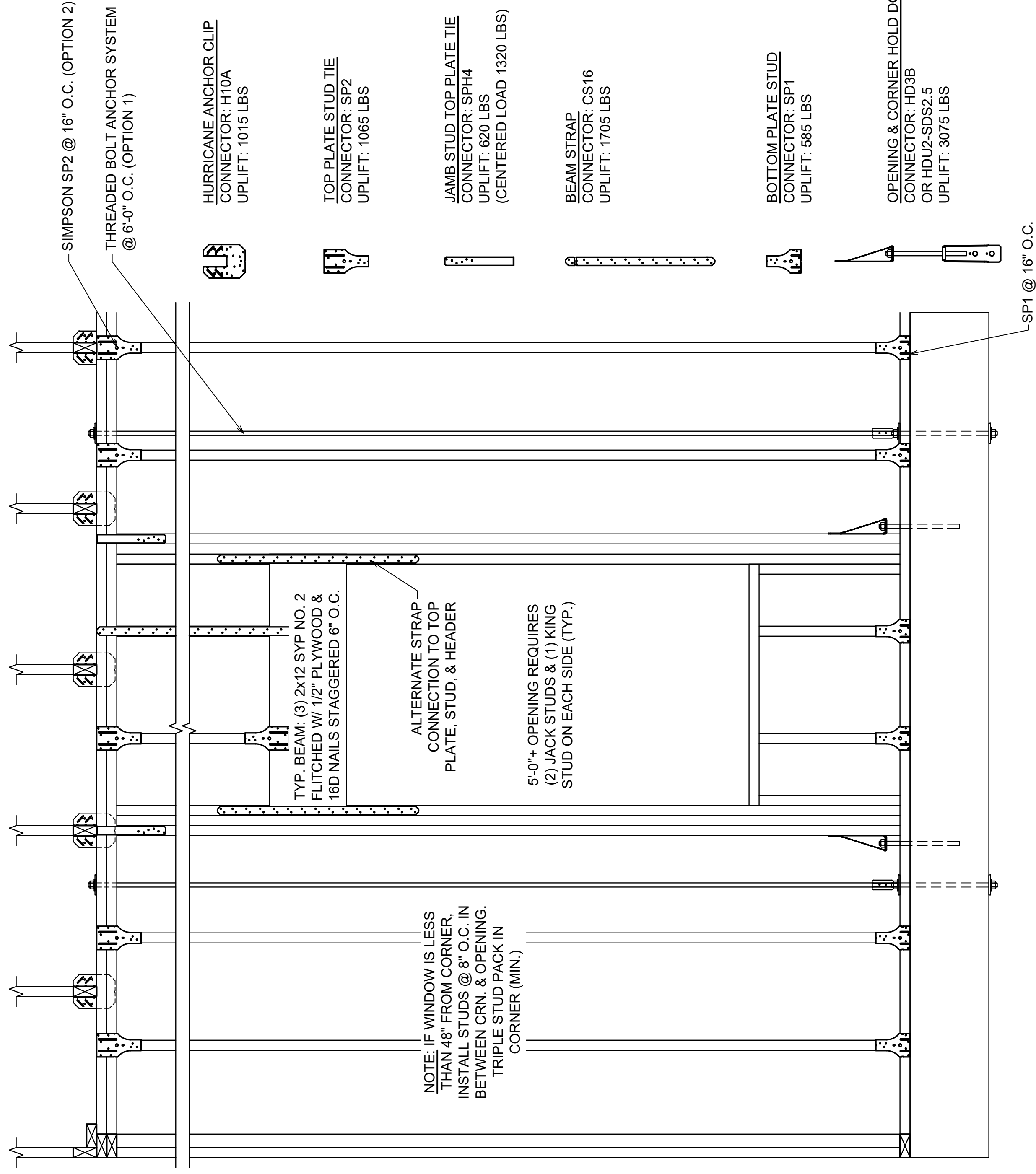

**TYP. WALL @ SLAB CONNECTION DETAILS**  
 1/2" = 1'-0" (11X17) 1" = 1'-0" (22X34)

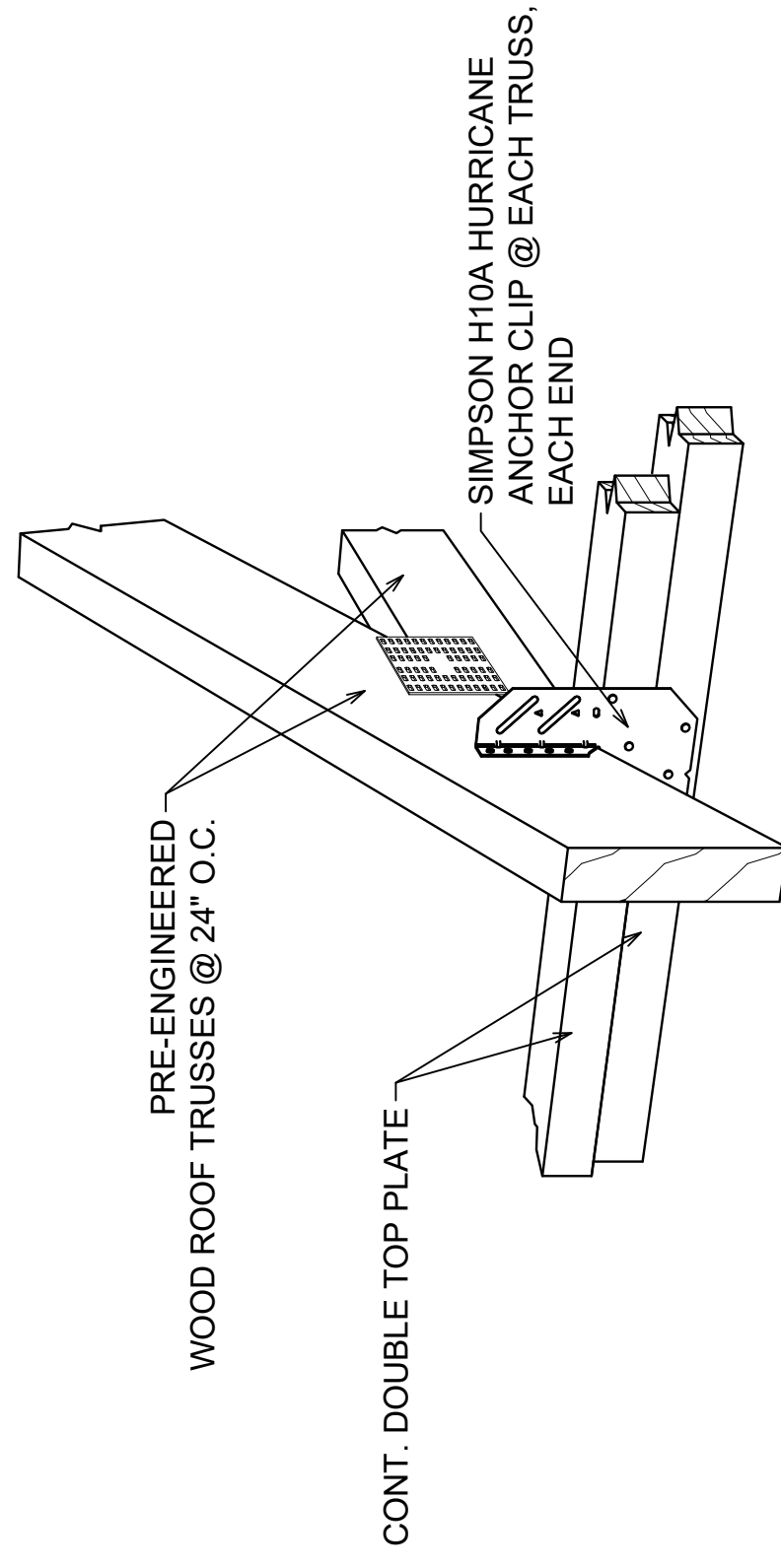

**TYP. H10A HURRICANE CLIP INSTALLATION**  
 NOT TO SCALE

OPENING SIZE	No. OF JACK STUDS	No. OF KING STUDS	No. OF BEAM STRAPS	No. OF JAMB STUD TIES	OPENING HOLD DOWN	CORNER HOLD DOWN
8'	2	2	2	2	HDU2-SDS2.5	HDU2-SDS2.5
7'	2	2	2	2	HDU2-SDS2.5	HDU2-SDS2.5
6'	2	2	2	2	HDU2-SDS2.5	HDU2-SDS2.5
5'	2	1	1	1	HDU2-SDS2.5	HDU2-SDS2.5
4'	1	1	1	1	HDU2-SDS2.5	HDU2-SDS2.5
3'	1	1	1	1	HDU2-SDS2.5	HDU2-SDS2.5

**NOTE:**  
 THREADED BOLT SYSTEM CAN BE USED IN PLACE OF SP1/SP2 & HOLD DOWNS; PROVIDED 5/8" RODDED SYSTEM 6" O.C. & WITHIN 12" OF CORNER & EACH OPENING SIDE.

**NOTE:**  
 OPTION 1 - THREADED BOLT SYSTEM; 5/8" ROD SYSTEM @ 6" O.C. & WITHIN 12" OF CORNER & EACH OPENING SIDE.

OPTION 2 - SIMPSON SP1 & SP2 HOLD DOWNS MAY BE USED IN LIEU OF THREADED ROD SYSTEM.

**2x6/2x4 CORNER FRAMING DETAIL**  
 NOT TO SCALE

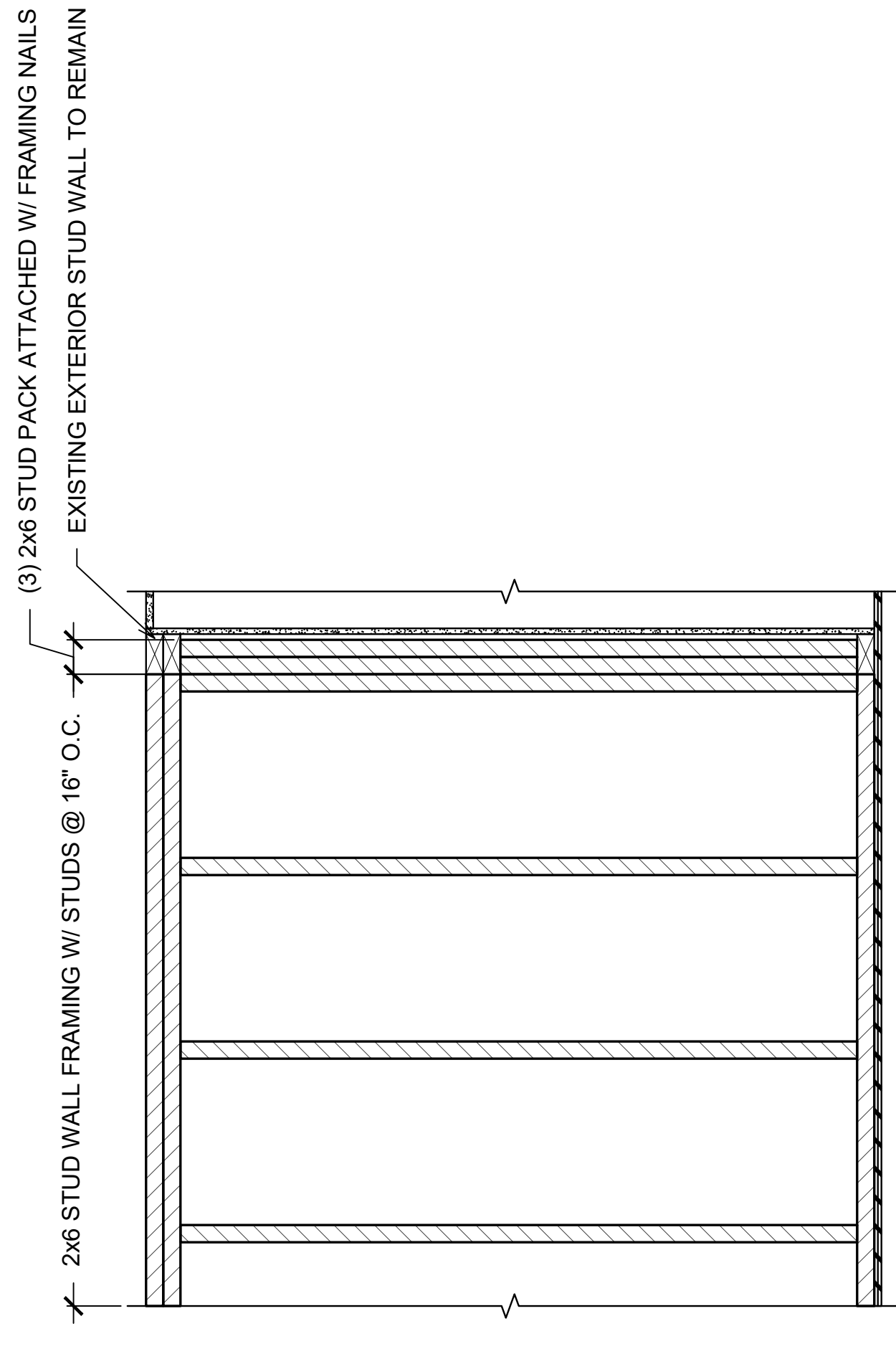
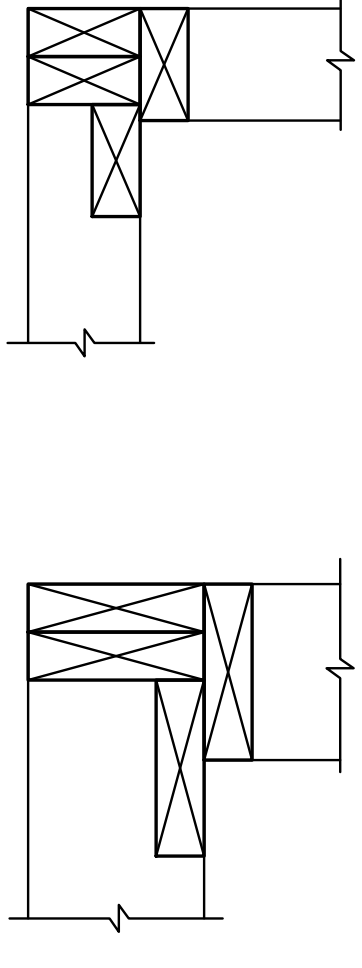

**1 NEW EXTERIOR WALL CONNECTION DETAIL**  
 1-1/2" = 1'-0" (11X17) 3" = 1'-0" (22X34)



**WEBER**  
 structural engineering  
 3000 W. 29th Street  
 Palm City, FL 32905  
 m@weber.com

Michael K. Weber P.E.  
 FL P.E. #75798

REVISIONS:  
 COMMENTS:  
 DATE:

RENOVATIONS FOR:  
 CALLAWAY HISTORIC SOCIETY  
 522 BEULAH AVE.  
 CALLAWAY, FLORIDA

WALL CONNECTION  
 DETAILS

12/4/2019  
 Project No.: 19330  
 Drawn By: JCC  
 Checked By: MKW

Drawing Number  
**S3.1**

## ELECTRICAL LEGEND

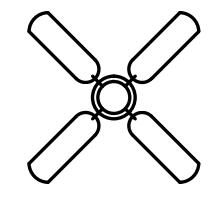

### LIGHTING

FAN / LIGHT FIXTURE AS SELECTED BY OWNER, SWITCH AS REQUIRED

LIGHT FIXTURE AS SELECTED BY OWNER

WALL MOUNTED LIGHTING FIXTURE AS SELECTED BY OWNER

FIXTURE AS SELECTED BY OWNER

WALL MOUNTED FIXTURE AS SELECTED BY OWNER

RECESSED CAN LIGHT FIXTURE AS SELECTED BY OWNER

SOFFIT MOUNTED FLOOD LAMP FIXTURE AS SELECTED BY OWNER

FAN / LIGHT FIXTURE AS SELECTED BY OWNER, SWITCH AS REQUIRED

UNDERCOUNTER LIGHTING AS SELECTED BY OWNER

### WALL SWITCHES

\$ A.C. TYPE, SINGLE POLE, 20 AMP, 120/277 VOLT, (UNLESS OTHERWISE NOTED, MOUNT 48" A.F.F.)

3 \$ A.C. TYPE, 3 WAY, 20 AMP, 120/277 VOLT, (UNLESS OTHERWISE NOTED, MOUNT 48" A.F.F.)

### BRANCH CIRCUITING

RUN CONCEALED IN CEILING OR WALLS

### PANELS AND POWER

ELECTRICAL SERVICE PANEL

NON-FUSIBLE HVAC DISCONNECT SWITCH

### FIRE ALARM SYSTEM

CEILING OR WALL MOUNTED SMOKE DETECTOR AND/OR CARBON MONOXIDE DETECTOR

S.D.

### WALL OUTLETS

⊖ DUPLEX RECEPTACLE - 20 AMP, 125 VOLT, 2 POLE, 3 WIRE GROUNDED TYPE, NEMA 5-20R. MOUNT MIN. 12" A.F.F. UNLESS NOTED OTHERWISE.

⊖ WP DUPLEX RECEPTACLE - 20 AMP, 125 VOLT, GFI, 2 POLE, 3 WIRE GROUNDED TYPE, NEMA 5-20R. MOUNT MIN. 12" A.F.F. UNLESS NOTED OTHERWISE; PROVIDE WEATHERPROOF BOX FOR RECEPTACLE

⊖ DUPLEX RECEPTACLE - 20 AMP, 125 VOLT, 2 POLE, 3 WIRE GROUNDED TYPE, NEMA 5-20R. MOUNT 6" ABOVE COUNTER

⊖ GFI DUPLEX RECEPTACLE - 20 AMP, 125 VOLT, GFI, 2 POLE, 3 WIRE GROUNDED TYPE, NEMA 5-20R. MOUNT 6" ABOVE COUNTER

⊖ 220 VOLT, OR AS REQUIRED

⊖ SPECIAL SERVICE RECEPTACLE OR JUNCTION BOX

### MISCELLANEOUS

⊖ WALL MOUNTED THERMOSTAT

### ELECTRICAL NOTES:

- THIS PLAN IS DIAGRAMMATIC AND ACTUAL LAYOUT / DESIGN MAY VARY FROM SHOWN. ELECTRICAL FIXTURES AS PER OWNER / CONTRACTOR.
- ELECTRICAL DESIGN & INSTALLATION TO BE BY A FLORIDA LICENSED ELECTRICAL CONTRACTOR PER N.E.C. REQUIREMENTS / LOCAL CODES.
- ELECTRICAL CONTRACTOR TO PROVIDE AND SIZE ELECTRICAL SERVICE PANELS, BREAKERS, AND/OR DISCONNECTS AS REQUIRED BY ELECTRICAL SYSTEM AND /OR CODES.
- ELECTRICAL CONTRACTOR SHALL COORDINATE ALL WORK WITH OTHER TRADES PRIOR TO INSTALLATION.
- HVAC DESIGN & INSTALLATION TO BE BY A FLORIDA LICENSED MECHANICAL CONTRACTOR IN ACCORDANCE WITH D.C.A. ENERGY CODE REQUIREMENTS.
- PROVIDE ANY ADDITIONAL DATA COMM. AND/OR TELEVISION OUTLETS AS DIRECTED AND COORDINATED BY OWNER AND/OR GENERAL CONTRACTOR

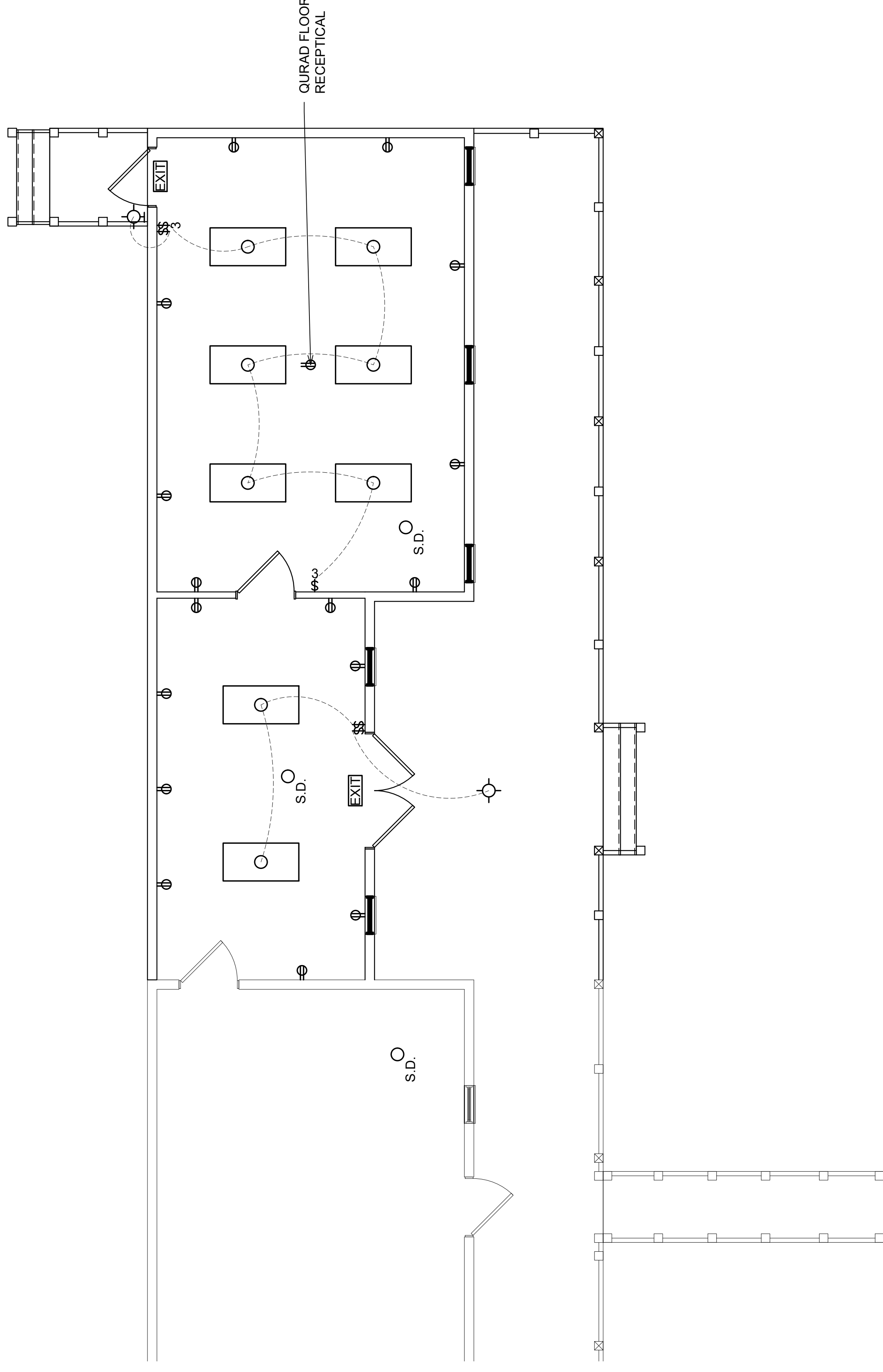

**1** FIRST FLOOR ELECTRICAL PLAN  
1/8" = 1'-0" (11x17) 1/4" = 1'-0" (22x34)

REVISIONS:	COMMENTS:	DATE:

## **SPECIAL FEDERAL PROVISIONS**

### **A. GRANT CONDITIONS**

FEMA funding requirements apply to projects funding in part or in whole with funds made available by the Federal government.

#### **1. Goals for Women and Minorities in Construction**

Department of Labor regulations set forth in 41 CFR 60-4 establish goals and timetables for participation of minorities and women in the construction industry. These regulations apply to all Federally-assisted construction contracts in excess of \$10,000. The recipient must comply with these regulations and must obtain compliance with 41 CFR 60-4 from contractors and subcontractors employed in the completion of the project by including such notices, clauses and provisions in the Solicitations for Offers or Bids as required by 41 CFR 60-4. The goal for participation of women in each trade area must be as follows:

- a. From April 1, 1981, until further notice: 6.9 percent;
- b. All changes to this goal, as published in the Federal Register in accordance with the Office of Federal Contract Compliance Programs regulations at CFR 60- 4.6, or any successor regulations, must hereafter be incorporated by reference into these Special Award Conditions; and,
- c. Goals for minority participation must be as prescribed by Appendix B-Federal Register, Volume 45, No. 194, October 3, 1980, or subsequent publications. The Recipient must include the "Standard Federal Equal Employment Opportunity Construction Contract Specifications" (or cause them to be included if appropriate) in all federally assisted contracts subcontracts. The goals and timetables for minority and female participation may not be less than those published pursuant to 41 CFR 60-6.

#### **2. Contracting with small and minority businesses, women's business enterprise, and labor surplus area firms**

The non-federal entity must take all necessary affirmative steps to assure that minority businesses, women's business enterprises, and labor surplus area firms are used when possible. Affirmative steps must include:

- a. Placing qualified small and minority businesses and women's business enterprises on solicitation lists;
- b. Assuring that small and minority businesses, and women's business enterprises are solicited whenever they are potential sources;
- c. Dividing total requirements, when economically feasible, into smaller tasks quantities to permit maximum participation by small and minority business, and women's business enterprises;
- d. Establishing delivery schedules, where the requirement permits, which encourage participation by small and minority businesses, and women's business enterprises;
- e. Using the services and assistance, as appropriate, of such organizations as the Small Business Administration and the Minority Business Development Agency of the Department of Commerce; and,

- f. Requiring the prime contractor, if subcontracts are to be let, to take the affirmative steps listed in (a) — (e) of this paragraph.

### **3. Davis Bacon Act, as amended (40 U.S.C.3141—3148)**

Davis-Bacon Act-related provisions are applicable for a construction project if it is for the construction of a project that can be defined as a “treatment works” in 33 U.S.C 1292; or for a construction project regardless of whether it is a “treatment works” project if it is receiving federal assistance from another federal agency operating under an authority that requires the enforcement of Davis-Bacon Act-related provisions. When required, all prime construction contracts in excess of \$2,000 awarded by the non-Federal entity must include a provision for compliance with the Davis-Bacon Act (40 U.S.C. 3141—3144, and 3146—3148) as supplemented by Department of Labor regulations (29 CFR Part 5, “Labor Standards Provisions Applicable to Contracts Covering Federally Financed and Assisted Construction”). In accordance with the statute, contractors must be required to pay wages to laborers and mechanics at a rate not less than the prevailing wages specific in a wage determination made by the Secretary of Labor. In addition contracts must be required to pay wages not less than once a week.

The non-Federal entity must place a copy of the current prevailing wage determination issued by the Department of Labor in each solicitation. The decision to award a contract or subcontract must be conditioned upon the acceptance of the wage determination. The non-Federal entity must report all suspected or reported violations to Treasury. The contracts must also include a provision for compliance with the Copeland “Anti-Kickback” Act (40 U.S.C. 3145), as supplemented by Department of Labor regulations (29 CFR Part 3, “Contracts and Subcontractors on Public Building or Public Work Financed in Whole or in Part by Loans or Grants from the United States”). The Act provides that each contractor or sub-recipient must be prohibited from inducing, by any means, any person employed in the construction, completion, or repair of public work, to give up any part of the compensation or which he or she is otherwise entitled. The non-federal entity must report all suspected or reported violations to Treasury. See Attachment Nos. 1, 2, and 3 of this Section.

### **4. Equal Opportunity Clause**

Pursuant to 41 CFR 60-1.4(b), Federally assisted construction contracts, for construction which is not exempt from the requirements of the equal opportunity clause, 41 CFR Part 60-1—Obligations of Contractors and Subcontractors, [t]he [recipient] hereby agrees that it will incorporate or cause to be incorporated into any contract for construction work, or modification thereof, as defined in the regulations of the Secretary of Labor at 41 CFR Chapter 60, which is paid for in whole or in part with funds obtained from the federal government or borrowed on the credit of the federal government pursuant to a grant, contract, loan, insurance, or guarantee, or undertaken pursuant to any federal program involving such grant, contract, loan, insurance, or guarantee, the following equal opportunity clause:

41 CFR §60-1.4 Equal opportunity clause. During the performance of this contract, the contractor agrees as follows:

(1) The contractor will not discriminate against any employee or applicant for employment because of race, color, religion, sex, sexual orientation, gender identity, or national origin. The contractor will take affirmative action to ensure that applicants are employed, and that employees are treated during employment without regard to their race, color, religion, sex, sexual orientation, gender identity, or national origin. Such action shall include, but not be limited to the following:

Employment, upgrading, demotion, or transfer; recruitment or recruitment advertising; layoff or termination; rates of pay or other forms of compensation; and selection for training, including



apprenticeship. The contractor agrees to post in conspicuous places, available to employees and applicants for employment, notices to be provided setting forth the provisions of this nondiscrimination clause.

(2) The contractor will, in all solicitations or advertisements for employees placed by or on behalf of the contractor, state that all qualified applicants will receive consideration for employment without regard to race, color, religion, sex, sexual orientation, gender identity, or national origin.

(3) The contractor will not discharge or in any other manner discriminate against any employee or applicant for employment because such employee or applicant has inquired about, discussed, or disclosed the compensation of the employee or applicant or another employee or applicant. This provision shall not apply to instances in which an employee who has access to the compensation information of other employees or applicants as a part of such employee's essential job functions discloses the compensation of such other employees or applicants to individuals who do not otherwise have access to such information, unless such disclosure is in response to a formal complaint or charge, in furtherance of an investigation, proceeding, hearing, or action, including an investigation conducted by the employer, or is consistent with the contractor's legal duty to furnish information.

(4) The contractor will send to each labor union or representative of workers with which he has a collective bargaining agreement or other contract or understanding, a notice to be provided advising the said labor union or workers' representatives of the contractor's commitments under this section, and shall post copies of the notice in conspicuous places available to employees and applicants for employment.

(5) The contractor will comply with all provisions of Executive Order 11246 of September 24, 1965, and of the rules, regulations, and relevant orders of the Secretary of Labor.

(6) The contractor will furnish all information and reports required by Executive Order 11246 of September 24, 1965, and by rules, regulations, and orders of the Secretary of Labor, or pursuant thereto, and will permit access to his books, records, and accounts by the administering agency and the Secretary of Labor for purposes of investigation to ascertain compliance with such rules, regulations, and orders.

(7) In the event of the contractor's noncompliance with the nondiscrimination clauses of this contract or with any of the said rules, regulations, or orders, this contract may be canceled, terminated, or suspended in whole or in part and the contractor may be declared ineligible for further Government contracts or federally assisted construction contracts in accordance with procedures authorized in Executive Order 11246 of September 24, 1965, and such other sanctions may be imposed and remedies invoked as provided in Executive Order 11246 of September 24, 1965, or by rule, regulation, or order of the Secretary of Labor, or as otherwise provided by law.

(8) The contractor will include the portion of the sentence immediately preceding paragraph (1) and the provisions of paragraphs (1) through (8) in every subcontract or purchase order unless exempted by rules, regulations, or orders of the Secretary of Labor issued pursuant to section 204 of Executive Order 11246 of September 24, 1965, so that such provisions will be binding upon each subcontractor or vendor. The contractor will take such action with respect to any subcontract or purchase order as the administering agency may direct as a means of enforcing such provisions, including sanctions for noncompliance. Provided, however, that in the event a contractor becomes involved in, or is threatened with, litigation with a subcontractor or vendor as a result of such direction by the administering agency, the contractor may request the United States to enter into such litigation to protect the interests of the United States. The applicant further agrees that it will be bound by the above equal opportunity clause with respect to its own employment practices when it participates in

federally assisted construction work: Provided, That if the applicant so participating is a State or local government, the above equal opportunity clause is not applicable to any agency, instrumentality or subdivision of such government which does not participate in work on or under the contract. The applicant agrees that it will assist and cooperate actively with the administering agency and the Secretary of Labor in obtaining the compliance of contractors and subcontractors with the equal opportunity clause and the rules, regulations, and relevant orders of the Secretary of Labor, that it will furnish the administering agency and the Secretary of Labor such information as they may require for the supervision of such compliance, and that it will otherwise assist the administering agency in the discharge of the agency's primary responsibility for securing compliance. The applicant further agrees that it will refrain from entering into any contract or contract modification subject to Executive Order 11246 of September 24, 1965, with a contractor debarred from, or who has not demonstrated eligibility for, Government contracts and federally assisted construction contracts pursuant to the Executive Order and will carry out such sanctions and penalties for violation of the equal opportunity clause as may be imposed upon contractors and subcontractors by the administering agency or the Secretary of Labor pursuant to Part II, Subpart D of the Executive Order. In addition, the applicant agrees that if it fails or refuses to comply with these undertakings, the administering agency may take any or all of the following actions: Cancel, terminate, or suspend in whole or in part this grant (contract, loan, insurance, guarantee); refrain from extending any further assistance to the applicant under the program with respect to which the failure or refund occurred until satisfactory assurance of future compliance has been received from applicant; and refer the case to the Department of Justice for appropriate legal proceedings.

#### **5. Revised ADA Standards for Accessible Design for Construction Awards**

The U.S. Department of Justice has issued revised regulations implementing Title II of the ADA (28 C.F.R. Part 35) and Title III of the ADA (28 C.F.R. Part 36). The revised regulations adopted new enforceable accessibility standards called the "2010 ADA Standards for Accessible Design" (2010 Standards). The 2010 Standards are an acceptable alternative to the Uniform Federal Accessibility Standards (UFAS). Treasury deems compliance with the 2010 Standards to be an acceptable means of complying with the Section 504 accessibility requirements for new construction and alteration projects.

#### **6. Historic Artifact Discovery**

If prehistoric or historic artifacts, such as pottery or ceramics, projectile points, dugout canoes, metal implements, historic building materials, or any other physical remains that could be associated with Native American, early European, or American settlement are encountered at any time within the project site area, the permitted project shall cease all activities involving subsurface disturbance in the vicinity of the discovery. The applicant shall contact the Florida Department of State, Division of Historical Resources, Compliance Review Section at (850)-245-6333. Project activities shall not resume without verbal and/or written authorization. In the event that unmarked human remains are encountered during permitted activities, all work shall stop immediately and the proper authorities notified in accordance with Section 872.05, Florida Statutes.



**PROPOSAL CHECKLIST**  
**CITY OF CALLAWAY**  
**STORAGE BUILDING REBUILD**  
**BID NO: CM2020-02**

**FORMS/ITEMS TO BE RETURNED  
WITH YOUR PROPOSAL!**

The following forms are to be completed/signed by the Proposer and submitted to the City:

1. Bid/RFP Certification Form(s),
2. One (1) unbound original with original, notarized signatures required, plus five (5) copies,
3. Bid Bond or Cashier's Check/Certified Check in the amount of 5% of bid,
4. Proof of Insurance in amounts required by the City with the City listed as Certificate Holder and Additionally Insured (See Special Instructions & Conditions),
5. State of Florida Business License
6. Public Entity Crime Statement,  
[Complete items 1 and 6; notarized signature required]
7. Drug-Free Workplace Certification Form,  
[Complete Part I; notarized signature, or sign Part II]
8. List of Subcontractors with names of directors or owners, addresses, telephone numbers, and email address (if applicable),
9. List of references for similar type work with contact information.
10. Proprietary/Confidential Information Form

**Note:** Incomplete Bid/Proposal submissions may not be accepted/considered. Do not modify the forms! Any additional information you desire to present may be included as an attachment.

**Reminder:** Submit requested number of copies! (See Special Instructions and Conditions)

**BID/RFP CERTIFICATION FORM**  
**CITY OF CALLAWAY**  
**STORAGE BUILDING REBUILD**  
**BID NO: CM2020-02**

PROPOSERS CERTIFICATION TO THE CITY OF CALLAWAY:

1. The undersigned warrants that: (A) This Proposal is submitted in response to, and is in compliance with, all terms and conditions applicable thereto as set forth in the Advertisement, Instructions to Proposers, General Instructions and Conditions, Special Instructions and Conditions, Bid/RFP Certification Forms, the Minimum Technical Specifications, Addendum, Exhibits, Agreement, Bonds, and Insurance Requirements, each of which has been carefully examined, (B) Proposer or Proposer's representative has made such investigation as is necessary to determine the character and extent of the work and their capability to perform the work, and (C) agrees that if the Proposal is accepted by the City, Proposer will provide the necessary labor, materials, machinery, equipment, tools or apparatus, and perform all the work or services required to complete the assignment and/or contract within the time specified according to the requirements of the City as herein and hereinafter set forth, and (D) he/she is authorized to legally execute binding contracts for and on behalf of the Proposer.
2. Please check one:
  - Proposer declares that the only person, persons, company, or parties interested in this Proposal are named in the Proposal.
  - Proposer, or one or more of Proposer's officers, principals, or any owner of more than 5% in or of proposer, or members of their immediate families: (A) have a financial interest in another company, project, or property that could benefit financially from this proposed project; and/or (B) another individual or business will be compensated by (or on behalf of proposer) if Proposer is selected by the City for the requested services. (Attach a detailed explanation for either.)
3. Bid Bond - If the Proposal is accepted by the City, it will become a binding contract on both parties. If a Bid Bond or Cashier's Check/Certified Check is required, it shall be submitted with the Proposal. If the undersigned shall fail to deliver or perform, or if applicable, execute a Contract as stated herein, then the City may, at its option, determine that the undersigned has abandoned the Award/Contract, and thereupon such Bid and/or Award shall be null and void, and any Cashier's Check/Certified Check or Bond accompanying this Bid shall be forfeited to and become the property of the City, and the full amount of said check, or if a Bid Bond, the full amount of such bond, shall be paid to the City as partial liquidated damages; otherwise, any Bond or Cashier's Check/Certified Check accompanying this Bid shall be returned to the undersigned within 30 calendar days from the date of Award, or if provisions for a Notice to Proceed are included, from the date of the Notice to Proceed.
4. Vendor proposes and agrees to provide all materials, services or equipment required for the City of Callaway **STORAGE BUILDING REBUILD BID NO: CM2020-02**, for the Total Sum(s) as follows (*totals must match attached breakdown of costs*): \_\_\_\_\_ Dollars (\$ \_\_\_\_\_).
5. Number of days from date of the Notice to Proceed that will be required for the final completion of all work as described herein.

\_\_\_\_\_

**(Maximum 60 Calendar Days)**
6. The City reserves the right to accept any or all prices itemized in any combination that best serves the interests of the City. The City further reserves the right to accept or reject any of the components of this Proposal, including alternates.

7. BIDDER HEREBY ACKNOWLEDGES RECEIPT OF THE FOLLOWING ADDENDUMS: \_\_\_\_\_

Name of Bidder: \_\_\_\_\_

Business structure: ( ) Corporation, ( ) Partnership, ( ) Individual, ( ) Other: \_\_\_\_\_

If a Partnership: \_\_\_\_\_

Name(s) of Partner(s): \_\_\_\_\_

If a Corporation: \_\_\_\_\_

Incorporated in State of: \_\_\_\_\_ Date of Incorporation: \_\_\_\_\_

Business Address: \_\_\_\_\_

City: \_\_\_\_\_ State \_\_\_\_\_ Zip \_\_\_\_\_

Telephone Number: ( ) \_\_\_\_\_ Fax ( ) \_\_\_\_\_

Submitted By: \_\_\_\_\_  
(Print)

Title: \_\_\_\_\_

Signature: \_\_\_\_\_

ATTEST: \_\_\_\_\_  
Secretary

By: \_\_\_\_\_  
Print Name

Affix Corporate Seal  
(If Corporation)

State of Florida  
County of

The foregoing instrument was acknowledged before me this \_\_\_ day of \_\_\_\_\_, 20\_\_, by \_\_\_\_\_,  
who is personally known to me or who presented \_\_\_\_\_ as identification, and who (did) (did not) take  
an oath.

\_\_\_\_\_  
[Signature of Notary Public]

\_\_\_\_\_  
[Printed, typed or stamped name of Notary Public]

**NOTE: BIDS MAY BE REJECTED IF ALL DOCUMENTS ARE NOT COMPLETE AND EXECUTED, AND THE NUMBER OF COPIES SPECIFIED/REQUESTED OF EACH ARE NOT SUBMITTED WITH THE BID.**

**SWORN STATEMENT PURSUANT TO SECTION 287.133(3)(a),  
FLORIDA STATUTES, ON PUBLIC ENTITY CRIMES**

**THIS FORM MUST BE SIGNED AND SWORN TO IN THE PRESENCE OF A NOTARY PUBLIC OR OTHER OFFICIAL AUTHORIZED TO ADMINISTER OATHS.**

1. This sworn statement is submitted to City of Callaway, Florida, a Municipal Corporation, 6601 East Hwy. 22, Callaway, Florida 32404 by \_\_\_\_\_  
[print individual's name and title]  
for \_\_\_\_\_ whose business  
[print name of entity submitting sworn statement]  
address is \_\_\_\_\_  
\_\_\_\_\_ and (if applicable) it's Federal Identification Number  
(FEIN) is \_\_\_\_\_ (If the entity has no FEIN, include the Social Security  
Number of the individual signing this sworn statement \_\_\_\_\_)
2. I understand that a "public entity crime" as defined in Paragraph 287.133(1)(g), **Florida Statutes**, means a violation of any state or federal law by a person with respect to and directly related to the transaction of business with any public entity or with an agency or political subdivision of any other state or of the United States, including, but not limited to, any bid or contract for goods or services to be provided to any public entity or any agency or political subdivision of any other state or of the United States and involving antitrust, fraud, theft, bribery, collusion, racketeering, conspiracy, or material misrepresentation.
3. I understand that "convicted" or "conviction" as defined in Paragraph 287.133(1)(b), **Florida Statutes**, means a finding of guilt or a conviction of a public entity crime, with or without an adjudication of guilt, in any federal or state trial court of record relating to charges brought by indictment or information after July 1, 1989, as a result of a jury verdict, non-jury trial, or entry of a plea of guilty or nolo contendere.
4. I understand that an "affiliate" as defined in Paragraph 287.133(1)(a), **Florida Statutes**, means:
  1. A predecessor or successor of a person convicted of a public entity crime; or
  2. An entity under the control of any natural person who is active in the management of the entity and who has been convicted of a public entity crime. The term "affiliate" includes those officers, directors, executives, partners, shareholders, employees, members, and agents who are active in the management of an affiliate. The ownership by one person of shares constituting a controlling interest in another person, or a pooling of equipment or income among persons when not for fair market value under an arm's length agreement, shall be a prima facie case that one person controls another person. A person who knowingly enters into a joint venture with a person who has been convicted of a public entity crime in Florida during the preceding 36 months shall be considered an affiliate.
5. I understand that a "person" as defined in Paragraph 287.133(1)(e), **Florida Statutes**, means any natural person or entity organized under the laws of any state or of the United States with the legal power to enter into a binding contract and which bids or applies to bid on contracts for the provision of goods or services let by a public entity, or which otherwise transacts or applies to transact business with a public entity. The term "person" includes those officers, directors, executives, partners, shareholders, employees, members, and agents who are active in management of an entity.

6. Based on information and belief, the statement which I have marked below is true in relation to the entity submitting this sworn statement. **[Indicate which statement applies.]**

\_\_\_\_\_ Neither the entity submitting this sworn statement, nor any of its officers, directors, executives, partners, shareholders, employees, members, or agents who are active in the management of the entity, nor any affiliate of the entity has been charged with and convicted of a public entity crime subsequent to July, 1 1989.

\_\_\_\_\_ The entity submitting this sworn statement, or one or more of its officers, directors, executives, partners, shareholders, employees, members, or agents who are active in the management of the entity, or an affiliate of the entity has been charged with and convicted of a public entity crime subsequent to July 1, 1989.

\_\_\_\_\_ The entity submitting this sworn statement, or one or more of its officers, directors, executives, partners, shareholders, employees, members, or agents who are active in the management of the entity, or an affiliate of the entity has been charged with and convicted of a public entity crime subsequent to July 1, 1989. However, there has been a subsequent proceeding before a Hearing Officer of the State of Florida, Division of Administrative Hearings and the Final Order entered by the Hearing Officer determined that it was not in the public interest to place the entity submitting this sworn statement on the convicted vendor list. **[attach a copy of the final order]**

**I UNDERSTAND THAT THE SUBMISSION OF THIS FORM TO THE CONTRACTING OFFICER FOR THE PUBLIC ENTITY IDENTIFIED IN PARAGRAPH 1 (ONE) ABOVE IS FOR THAT PUBLIC ENTITY ONLY AND, THAT THIS FORM IS VALID THROUGH DECEMBER 31 OF THE CALENDAR YEAR IN WHICH IT IS FILED. I ALSO UNDERSTAND THAT I AM REQUIRED TO INFORM THE PUBLIC ENTITY PRIOR TO ENTERING INTO A CONTRACT IN EXCESS OF THE THRESHOLD AMOUNT PROVIDED IN SECTION 287.017, FLORIDA STATUTES FOR CATEGORY TWO OF ANY CHANGE IN THE INFORMATION CONTAINED IN THIS FORM.**

\_\_\_\_\_  
**[signature]**

CM2020-02  
\_\_\_\_\_  
**[Reference: RFP Number]**

Sworn to and subscribed before me this \_\_\_ day of \_\_\_\_\_, 20\_\_\_. Personally known \_\_\_\_\_ or produced identification \_\_\_\_\_

**[Type of identification]**

Notary Public - State of \_\_\_\_\_

My Commission expires: \_\_\_\_\_

\_\_\_\_\_  
**[Signature of Notary]**

\_\_\_\_\_  
**[Printed, typed or stamped commissioned name of Notary Public]**

**CITY OF CALLAWAY**  
**DRUG-FREE WORKPLACE CERTIFICATION**

**Please complete Part I or Part II as applicable.**

In order to be given preference in the award process for having implemented a drug-free workplace program prior to the Bid/Proposal submission date, the Bidder/Proposer is requested to certify that as part of their drug-free workplace program, they have:

1. Published a statement notifying employees that the unlawful manufacture, distribution, dispensing, possession, or use of a controlled substance is prohibited in the workplace and specified the actions that will be taken against employees for violations of such prohibition.
2. Informed employees about the dangers of drug abuse in the workplace, the business policy of maintaining a drug-free workplace, any available drug counseling, rehabilitation, and employee assistance programs, and the penalties that may be imposed upon employees for drug abuse violations.
3. Given each employee engaged in providing the commodities or contractual services that are under bid a copy of the statement specified in Subsection 1.
4. In the statement specified in Subsection 1, notified the employees that, as a condition of working on the commodities or contractual services that are under bid, the employee will abide by the terms of the statement and will notify the employer of any conviction of, or plea of guilty or nolo contendere to, any violation of Chapter 893 or of any controlled substance law of the United States or any state, for a violation occurring in the workplace no later than five (5) days after such conviction.
5. Imposed a sanction on, or required the satisfactory participation in a drug abuse assistance or rehabilitation program if such is available in the employee's community by any employee who is so convicted.
6. Made a good faith effort to continue to maintain a drug-free workplace through implementation of this section.

**Part I - PROGRAM IMPLEMENTED**

I certify that I/we have established a drug-free workplace program meeting the foregoing minimum requirements.

\_\_\_\_\_ [Printed, typed name] \_\_\_\_\_ [Signature]

State of Florida  
County of \_\_\_\_\_

The foregoing instrument was acknowledged before me this \_\_\_\_ day of \_\_\_\_\_, 20\_\_, by \_\_\_\_\_, who is personally known to me or who presented \_\_\_\_\_ as identification, and who (did) (did not) take an oath.

\_\_\_\_\_ [Signature of Notary Public] \_\_\_\_\_ [Printed, typed or stamped name of Notary Public]

\_\_\_\_\_ [Commission Number of Notary Public]

**Part II - PROGRAM NOT IMPLEMENTED**

A program meeting the above stated requirements has not been established or has not been fully implemented prior to Bid/Proposal closing date, and therefore I/we are not eligible for certification as a drug-free workplace.

\_\_\_\_\_ [Signature] \_\_\_\_\_ [Date]



**PROPRIETARY/CONFIDENTIAL INFORMATION  
STORAGE BUILDING REBUILD  
RFP NO. CM2020-02**

**Name of Firm of Bidder/Vendor:** \_\_\_\_\_

Trade secrets or proprietary information submitted by a Vendor shall not be subject to public disclosure under the Freedom of Information Act; however, the Vendor must invoke such protections provided by state law, in writing, either before or at the time the data or other material is submitted. The written notice must specifically identify the data or materials to be protected, including the section of the proposal in which it is contained, as well as the page number(s), and state the reasons why protection is necessary. The proprietary or trade secret material submitted must be identified by some distinct method such as highlighting or underlining and must indicate only the specific words, figures, or paragraphs that constitute a trade secret or proprietary information. In addition, a summary of proprietary information provided shall be submitted on this form. The designation of an entire proposal document, line item prices, and/or total proposal prices as proprietary or trade secrets is not acceptable. If, after being given reasonable time, the Vendor refuses to withdraw such a classification designation, the proposal will be rejected.

SECTION/TITLE	PAGE NUMBER(S)	REASON(S) FOR WITHHOLDING FROM DISCLOSURE

**Check this box if there are none.**

*This document must be completed and returned with proposal.*