

Diode Light Source—LED

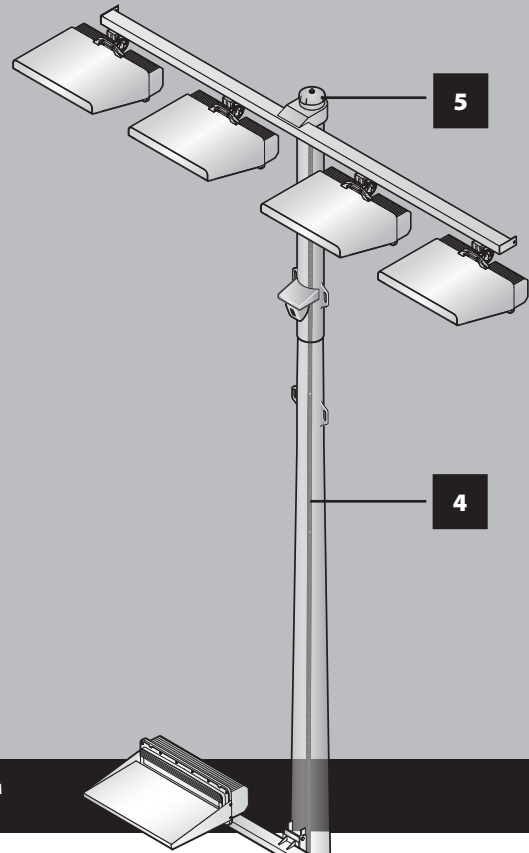

Installation Instructions: **Light-Structure System™**

Fast, trouble-free installation with
5 Easy Pieces™ approach to system design

5 Poletop Luminaire Assembly

4 Wire Harness

3 Electrical Components Enclosure

2 Galvanized Steel Pole

1 Precast Concrete Base

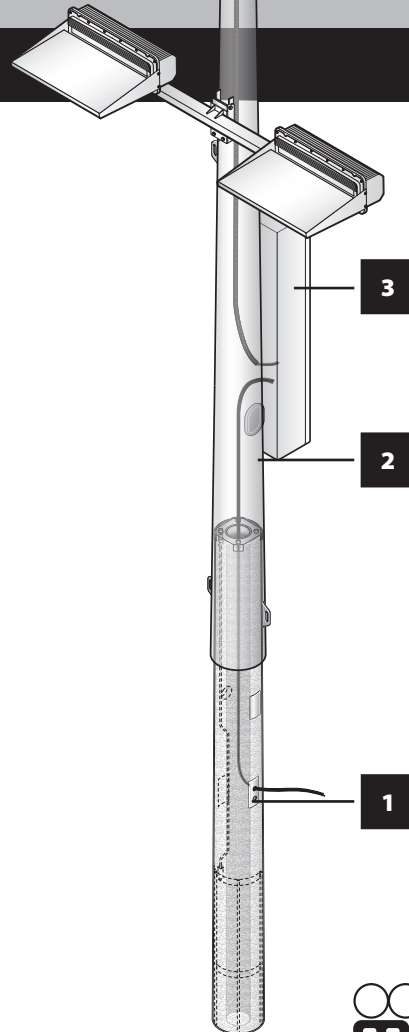

We Make It Happen.®

Table of Contents



Before You Begin
 Safety Information 3
 About These Instructions 4
 Standard Tools/Supplies Checklist 5
 Electrical System Requirements..... 6
 Components Matching and Labeling 7
 Documents We Provide..... 8
 Unloading Instructions 9

Precast Concrete Base
 Overview 10
 Installation Procedure..... 10

Galvanized Steel Pole and Poletop Luminaire Assembly
 Overview 13
 Assembly Procedure..... 13

Bolt-on Crossarms
 Overview 15
 Assembly Procedure..... 15

Electrical Components Enclosure
 Overview 18
 Assembly Procedure..... 18

Wire Harness
 Overview 23
 Assembly Procedure..... 23

Luminaire Attachment
 Overview 24
 Assembly Procedure..... 25

Pole Setting and Alignment
 Overview 28
 Installation Procedure..... 28

Connecting to Supply Wiring
 Overview 33
 Installation Procedure..... 33

Supplemental Instructions for Optional Features or Special Situations
 Provided with your project as needed

Painted Pole Special Requirements A
 Separating Steel Pole Sections C-1
 Separating Steel Pole from Concrete Base C-2
 Auxiliary Bracket D
 Platform, Climbing Steps, and Safety Cable E
 Climbing Steps and Safety Cable..... F
 External Lightning Grounding..... J
 Baseplate Pole K

Before You Begin

Safety Information

Electrical Safety Guidelines

Use extreme caution near overhead power lines or underground utilities. Observe all safety precautions for high-voltage equipment. Only qualified personnel may perform wiring. Follow all applicable building and electrical codes.

General Safety Guidelines

Follow proper safety procedures and established requirements during installation. Installers must wear the appropriate personal protective equipment including, but not limited to:

- Hard hat
- Steel-toed shoes
- Leather work gloves
- Eye protection
- High-visibility vest

Locate all underground utilities prior to digging.

All tools and equipment supplied by Musco are designed for specific use as described in these instructions. Do not use them in any other manner. Do not alter structural members in any way, such as bend, weld, or drill, without prior authorization from Musco.

Luminaire Mounting Information

Luminaire	Minimum Distance (per IEC/TR 62778) ¹	Projected Area (per IEC 60998-2-5) ²
TLC-LED-350	29 m (95 ft)	0.30 m ² (3.3 ft ²)
TLC-LED-400	29 m (95 ft)	0.49 m ² (5.3 ft ²)
TLC-LED-550	29 m (95 ft)	0.30 m ² (3.3 ft ²)
TLC-LED-550NR	29 m (95 ft)	0.34 m ² (3.7 ft ²)
TLC-BT-575	12 m (40 ft)	0.35 m ² (3.8 ft ²)
TLC-LED-600	29 m (95 ft)	0.49 m ² (5.3 ft ²)
TLC-LED-900	29 m (95 ft)	0.49 m ² (5.3 ft ²)
TLC-LED-900NB	no minimum	0.39 m ² (4.2 ft ²)
TLC-LED-1200	42 m (138 ft)	0.54 m ² (5.8 ft ²)
TLC-LED-1400NB	38 m (124 ft)	0.39 m ² (4.2 ft ²)
TLC-LED-1500	42 m (138 ft)	0.59 m ² (6.3 ft ²)
TLC-RGB-U	12 m (40 ft)	0.09 m ² (0.95 ft ²)
TLC-RGBW/ TLC-RGBA	15 m (49 ft)	0.49 m ² (5.3 ft ²)
TLC-BT-1500	42 m (138 ft)	0.59 m ² (6.3 ft ²)
TLC-RGBW-U/ TLC-RGBA-U	15 m (49 ft)	0.18 m ² (1.9 ft ²)

1. The luminaire should be positioned so that prolonged staring into the luminaire at a distance closer than listed in the above table for respective luminaire model is not expected. See table.
2. Represents geometric area only. Your structures have been designed using Effective Projected Area (EPA).







Install luminaires outside arm's reach of unauthorized personnel.

Before You Begin

About These Instructions

These instructions give basic assembly procedures for the Light-Structure System. They are not a comprehensive guide to all possible situations. Direct any questions to your local Musco representative.

Throughout this manual note these important symbols:

-  The safety alert symbol alerts you of situations that require care and caution to avoid serious personal injury.
-  The stop and check symbol signals you to stop and verify conditions before proceeding.
-  The contact Musco symbol appears in special situations where you may need to contact Musco for further information.
-  The go-to arrow indicates a branch in a procedure for special situations. In the case of optional equipment, the instructions may be in another document.
-  The tip symbol points out advice that makes installation easier.
-  The recycle symbol identifies recyclable materials.

Before You Begin

Standard Tools/Supplies Checklist

Refer to supplemental instructions provided for additional tools required.

Contractor/installer supplied tools	Function	Page
Hammer, pry-bar, banding cutters	Unloading equipment	9
Water pump	Removing water from base holes (as needed)	11
Two 1½ ton chain-type come-alongs	Jacking pole sections together	13, 28, 32
Large Phillips-head screwdriver	Tightening captive screws to seal enclosure to pole hub	18, 19
Standard screwdriver	Tightening distribution lugs, 45 A disconnect switch	18, 33, 34
Torque wrench with ¾, 7/16 and 9/16 in sockets	Tightening luminaire retaining cable and spreader bar hardware	15, 17, 24, 27, 34
Electrical fish tape, electrician's tape	Feeding wire harness through pole	23
Spray paint, chalk, or flags	Marking points to sight in aiming	28
Chalk or pencil	Making alignment marks	32
10 ft (3 m) stepladder or small line truck	Connecting supply wires to electrical enclosure	33, 34
Musco supplied tools	Function	Page
Wooden base wedges	Setting base	10
Level with shim for base taper	Plumbing base	10, 11, 32
Steel bar	Setting base, seating pole on base	10, 32
1½ in socket, extension, breaker bar, and 1½ in wrench	Tightening structural fasteners	15, 16, 24, 27
5/32 in hex key	Attaching handhole covers on base and steel pole	10, 22, 23, 34
9/16 in wrench	Tightening poletop set screw, pole cap fastener, enclosure hanger bolt, and spreader bar hardware	13, 14, 17, 19, 23
Dishwashing liquid (original Dawn®, ECOS® Pro, or DIAO™ brand)	Lubricating pole slip-fit connections	13, 28
Wooden shipping blocks	Elevating pole sections off ground during assembly	9, 13
7/16 in ratcheting combination wrench	Tightening captive bolts to secure luminaire assembly	24, 27
Pole rotator kit	Guiding pole onto base, pole alignment	28, 30, 32
Steel chain	Setting pole on base	32
5 mm hex key	Landing primary feed wires on 125 A disconnect switch	33
3/16 in hex key	Attaching grounding conductors inside electrical enclosure	33, 34
5/16 in hex key	Attaching grounding conductors inside pole at handhole	35
Machinery needed	Function	Page
Crane or forklift with nylon strapping and 8 ft (2.5 m) sling (sized to weight of base)	Unloading materials, setting bases	9, 10, 30
Auger	Excavate holes for bases	11
Load-rated crane, nylon slings, and shackles	Setting poles	28

Documents You Need

- Musco Foundation And Pole Assembly Drawing
- Field Aiming Diagram
- Stamped Foundation and Pole Design
- Control System Summary



If you do not have all of these documents, contact your local Musco representative.

Before You Begin

Electrical System Requirements

While the majority of the Light-Structure System™ can be assembled by non-professionals, a qualified electrician must handle the electrical supply installation and hook-up in accordance with national, state, and local codes. Your electrician should review this information before installation begins.

The electrician is generally required to provide these items:

- Service entrance
- Main power disconnect and distribution panel(s)
- Supply wiring and insulated equipment grounding conductors

Ensure supply wiring is rated for 90°C. Review the label inside the electrical components enclosure door and *Control System Summary* for voltage and phase requirements.

Luminaires generate up to 2.6 mA per driver on equipment grounding conductor and are designed to meet leakage current requirements per IEC 61347-1.

Basic insulation provided between RS-485 control input and main power supply.

Basic insulation provided between lighting controller (driver control/power and dimming relay) terminals and main power supply.

Inspect all wiring for damage prior to installation.

Always dispose of electronic waste in accordance with all applicable laws and regulations.

Other features that may affect the wiring supply requirements for this project include:

- Lighting contactor cabinets — refer to installation instructions provided with control equipment and the *Musco Control System Summary*.
- Control-Link® system — refer to installation instructions provided with control equipment and the *Musco Control System Summary*.
- Auxiliary bracket option — customer supplies all wiring for auxiliary components. Refer to *Installation Instructions: Auxiliary Bracket*.

Volunteer Installation

Have a qualified electrician review and complete the following:

- Create electrical system design — prior to installation.
- Provide and install trenching, supply wiring, and conduit.
- Complete all steps from *Connecting to Supply Wiring* section.
- Test complete lighting system.

Before You Begin

Components Matching and Labeling

Pole locations are identified by a pole ID (A1, A2, B1, B2, etc.) on the *Field Aiming Diagram*. These IDs are also marked on the individual components:

- Poletop luminaire assemblies, bolt-on crossarms, and luminaire shipping cartons
- Wire harnesses
- Electrical components enclosures
- Galvanized steel pole sections
- Precast concrete bases

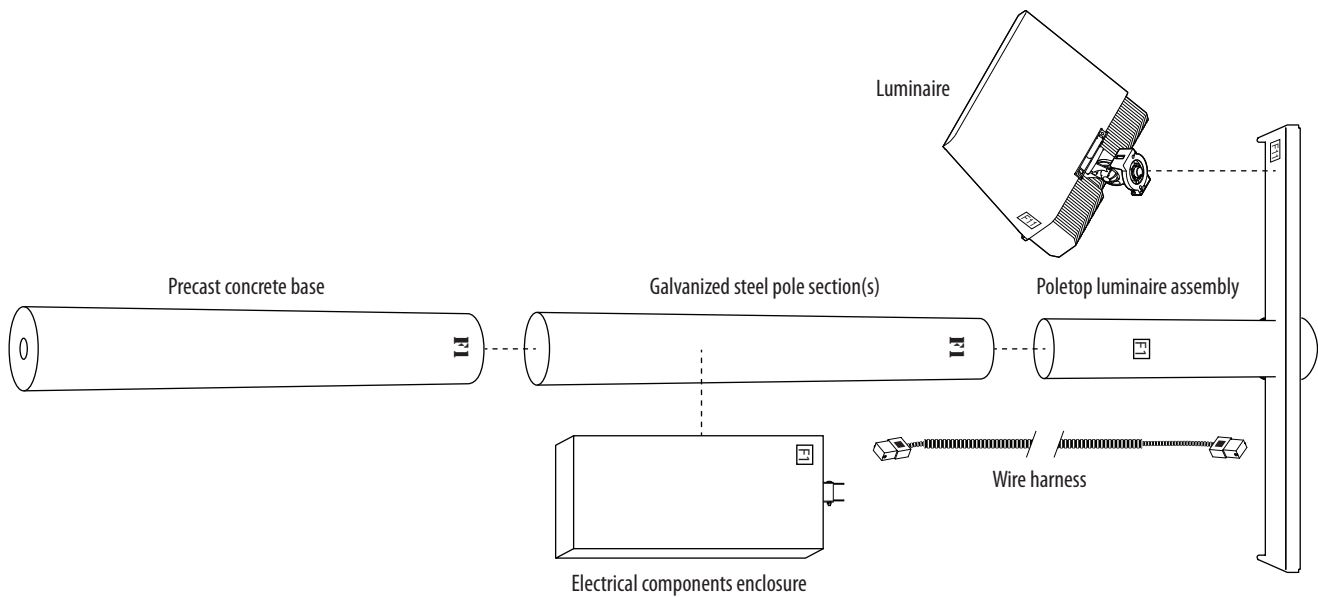

Before You Begin

Unloading Instructions

A typical shipment includes precast concrete bases, galvanized steel poles, electrical components enclosures, wire harnesses, and poletop luminaire assemblies with luminaires.



For ease of installation, set all matched components by the proper pole location as noted on the *Field Aiming Diagram*.

Tools/Materials Needed

- Crane with nylon web sling or forklift (load rated)
- Hammer
- Pry bar
- Banding cutters



Warning

Crushing hazard. Product is heavy and may roll.

Do not cut shipping bands or remove blocking from concrete bases or poles until they are supported by unloading equipment.

Use proper pick-up procedures conforming with local regulations when lifting concrete bases and poles. Balance point may not be at midpoint of base or pole.

- Check bill of lading to verify you have all materials.
- Inspect all materials for shipping damage.
- Store electrical components enclosures and luminaires in a dry location or cover with tarp until ready to install.



Painted poles require special handling, see *Instructions: Painted Pole Special Requirements*.



If additional information is needed, contact your local Musco representative.



Save wooden shipping blocks to use during pole assembly.



Please recycle. Luminaires, wire harnesses, and other components are shipped in recyclable cardboard packaging.



Precast Concrete Base

Overview

The precast concrete base is set directly into the ground, backfilled with concrete, and allowed to cure for 12 to 24 hours. The base is designed for easy slip-fit connection to the galvanized steel pole. The remaining components — steel pole, poletop luminaire assembly, electrical components enclosure, and wire harness — are assembled as a unit and set onto the base. The base includes an integrated lightning ground system.

Tools/Materials Needed



Musco Supplied

- Field Aiming Diagram
- Musco *Foundation and Pole Assembly Drawing* or stamped *Foundation and Pole Design*
- Steel bar
- Wooden base wedges
- Level with shim for tapered base
- 5/32 in hex key

Contractor Supplied

- Crane or forklift with nylon strapping and 8 ft (2.5 m) sling sized to weight of base
- Conduit for underground wiring
- Concrete backfill
- Water pump (as needed)

Installation Procedure

-  Verify pole ID on concrete base matches pole location on *Field Aiming Diagram*.
-  For Anchor Bolt foundations, see *Instructions: Baseplate Pole*.
-  For options on poor soil conditions, alternative installation methods, or if there are any issues with pole locations given, contact your local Musco representative. Your project engineer's name appears on *Field Aiming Diagram*.

Note: Use only project-specific foundation designs as detailed on Musco Foundation and Pole Assembly Drawing or stamped Foundation and Pole Design.

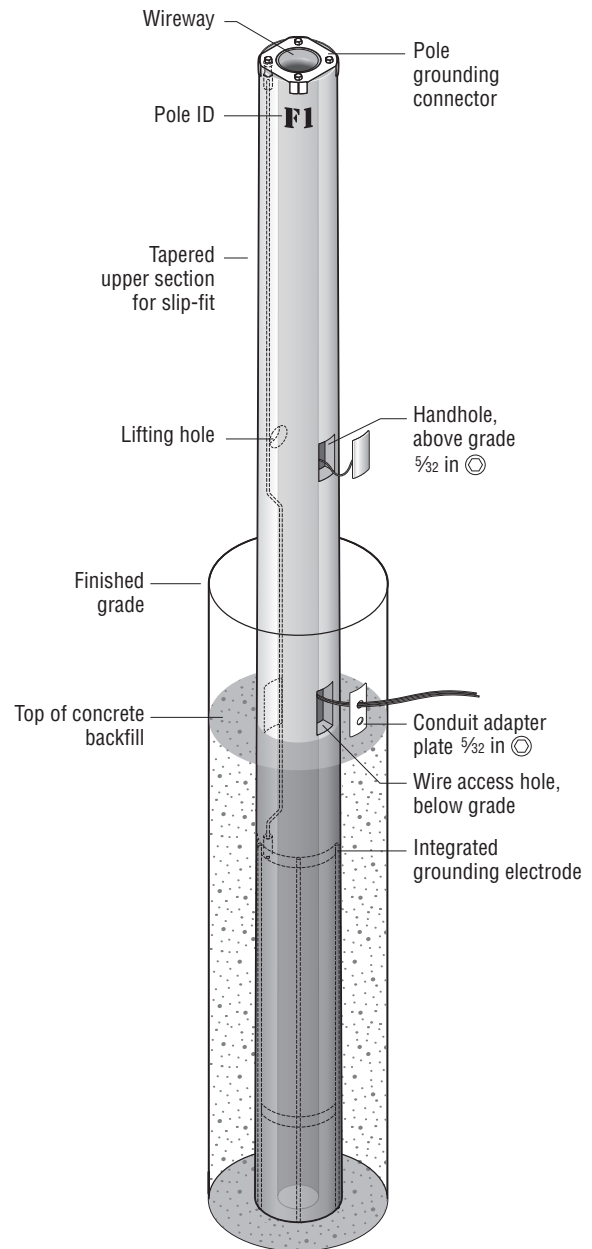

Precast Concrete Base

- 1** Mark pole locations per *Field Aiming Diagram*.
 - 2** Excavate holes to size and depth given on Musco *Foundation and Pole Assembly Drawing* or stamped *Foundation and Pole Design*.
- Warning**
Fall hazard
Cover holes or install fencing for fall safety.
- 3** Sling and lower base into hole. Orient wire access hole to accommodate incoming supply wiring. Snip banding and remove tab protectors.

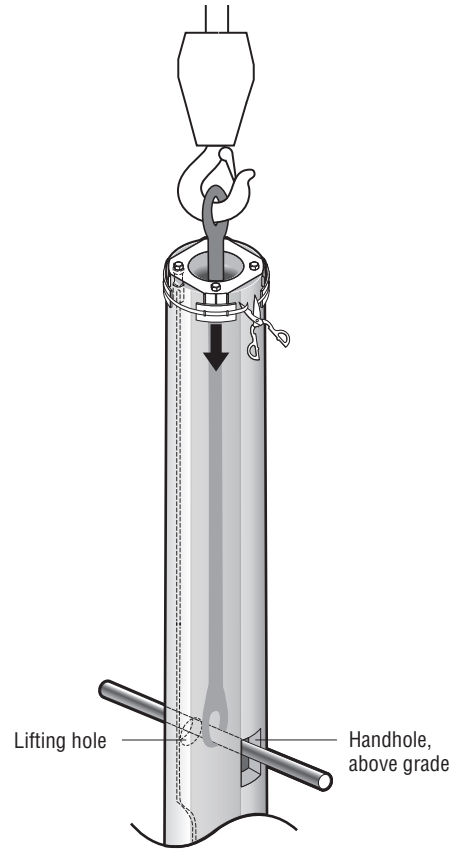

- 4** Plumb base and wedge into position. Use supplied level with shim on upper end against base. Shim accommodates taper of base. Top of base is beveled. Keep level at least 6 in (150 mm) from top when plumbing.

- 5** Remove any water from hole to avoid weakening foundation. Water in hole during concrete pour can also cause hollow center of base to fill with concrete.

-  If backfilling to finished grade with concrete instead of compacted fill, be sure to maintain wire access.

- 6** Backfill with concrete per Musco *Foundation and Pole Assembly Drawing* or stamped *Foundation and Pole Design*.

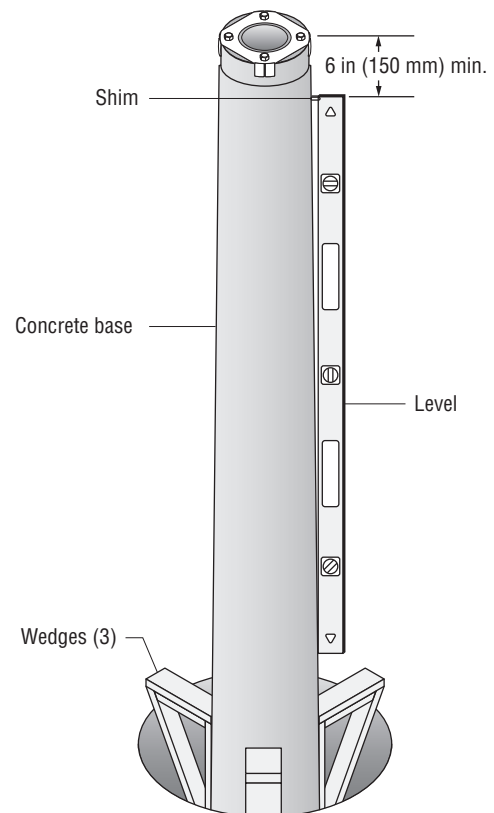

Precast Concrete Base

7

Have your electrician install all underground conduit and wiring, including insulated equipment grounding conductor. Route wires up through base to handhole. Conduit adapter plates with knockouts are provided. You may also install wiring after standing pole.

8

Backfill with compacted soil to finished grade unless stamped *Foundation and Pole Design* requires concrete to finished grade.

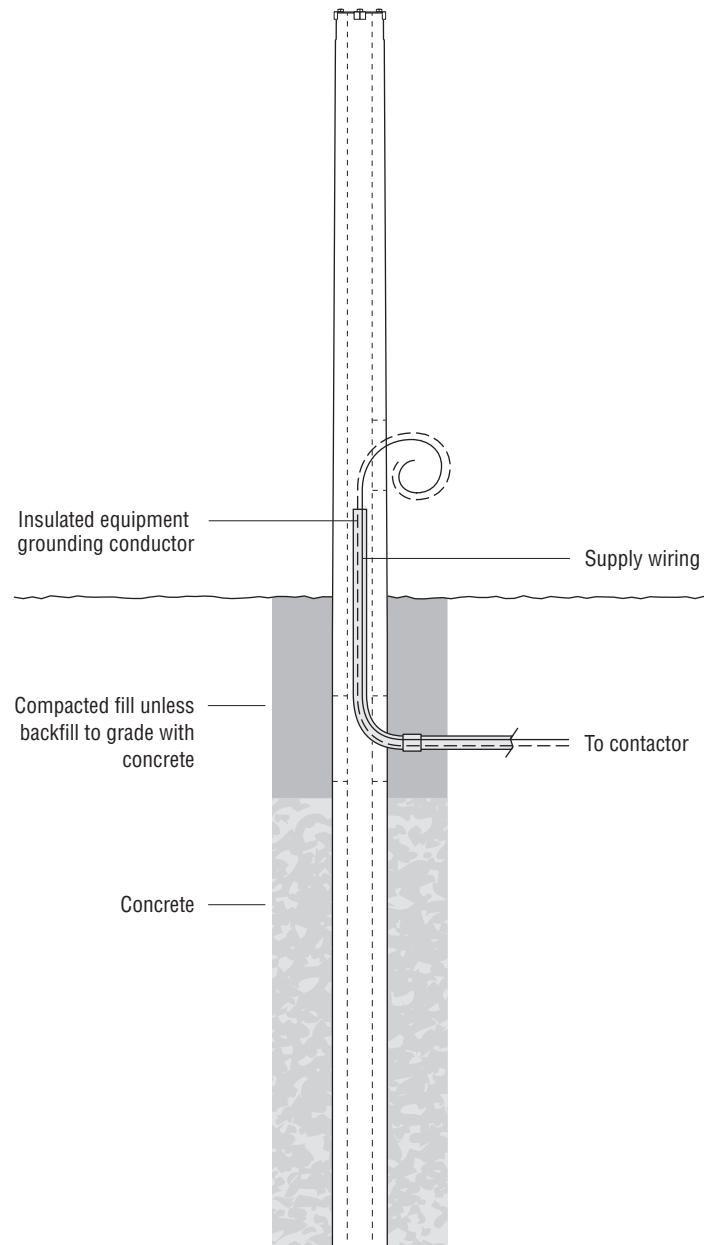

Galvanized Steel Pole and Poletop Luminaire Assembly

Overview

The galvanized steel pole and poletop luminaire assembly are designed to slip-fit together. Jacking ears on each pole section provide attachment points to pull pole sections together. The *Musco Foundation and Pole Assembly Drawing* gives minimum overlap specifications for each pole section.

Tools/Materials Needed

Musco Supplied

- Wooden shipping blocks
- Musco *Foundation and Pole Assembly Drawing*
- 5/16 in wrench
- Dishwashing liquid (original Dawn®, ECOS® Pro, or DIAO™ brand)

Contractor Supplied

- Two 1½ ton chain come-alongs

Assembly Procedure

 Verify pole ID on each steel pole section matches pole location on *Field Aiming Diagram*. Pole ID is stenciled on inside bottom end and outside top end of each section.

1 Lay out all pole sections and poletop luminaire assembly in sequence. Ensure all weldmarks face same direction. Weldmarks represent field side of pole.

 Use shipping blocks as necessary to support pole sections during assembly.

2 Lubricate top of each steel pole section with supplied dishwashing liquid.

3 Align jacking ears. Using two 1½ ton come-alongs, pull sections together evenly until tight. Ensure minimum overlap per *Musco Foundation and Pole Assembly Drawing*. Repeat for all sections.

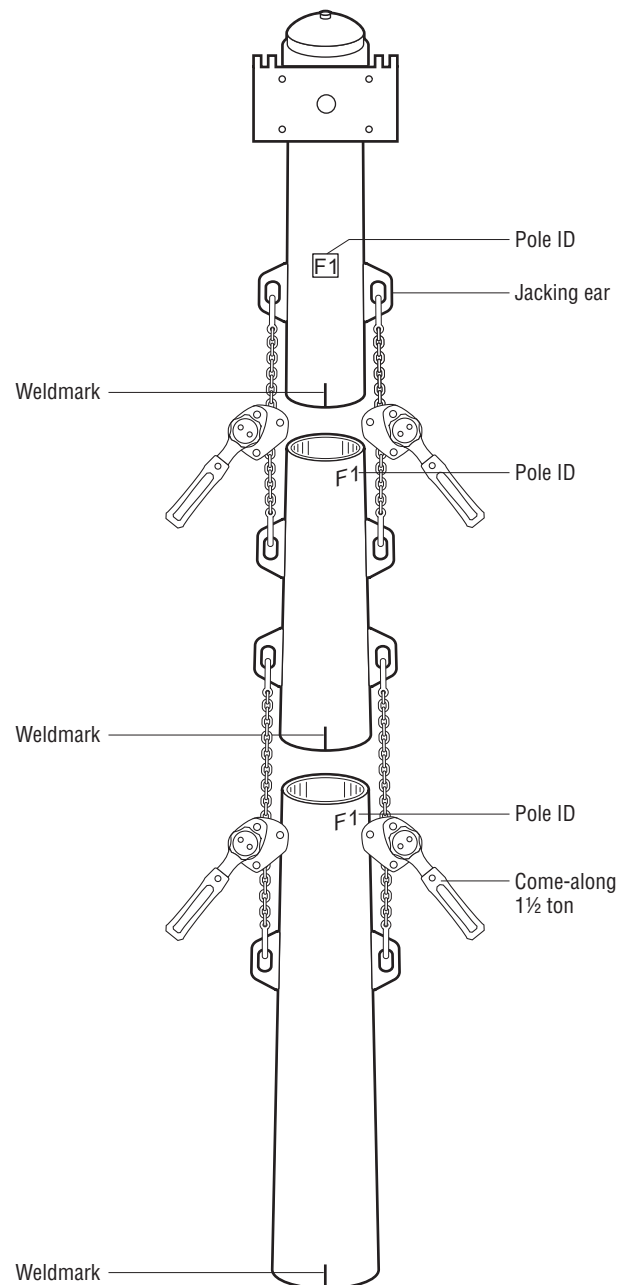

Galvanized Steel Pole and Poletop Luminaire Assembly

- 4** Tighten set screw using $\frac{1}{16}$ in wrench.
- 5** Remove protective cover from pole alignment device.

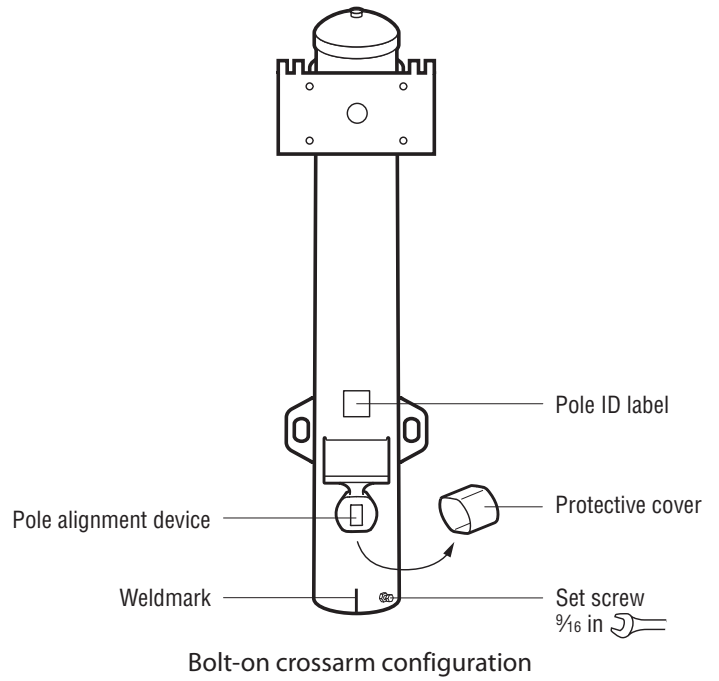

- ➡** If pole has welded crossarms, skip *Bolt-on Crossarms* section. Proceed to *Electrical Components Enclosure* section.
- ➡** See *Installation Instructions: Platform, Climbing Steps, and Safety Cable*, if your project includes these items.

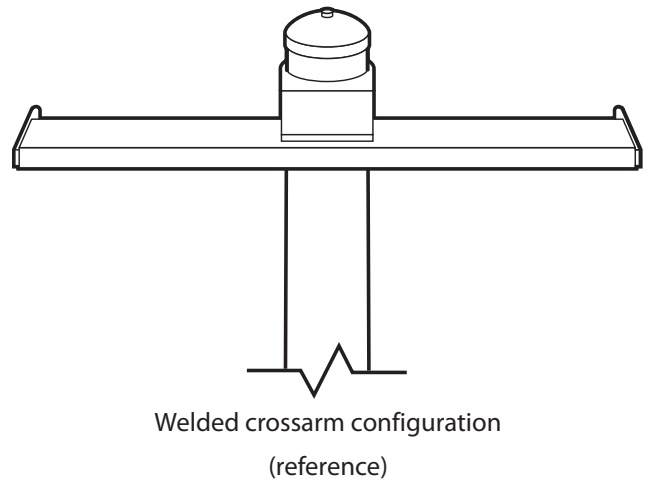

Bolt-on Crossarms

Overview

Due to shipping restrictions, it is sometimes necessary to ship crossarms separate from the poletop section. For these situations, the crossarms are designed to easily attach to the poletop.

Tools/Materials Needed

Musco Supplied:

- ¾ in drive 1½ in socket
- ¾ in drive breaker bar
- ¾ in drive 4 in extension
- 1½ in wrench
- Spreader bars
- ⅜ in fasteners (for spreader bars)
- ⅝ in structural fasteners
- ⅞ in wrench

Contractor Supplied:

- Torque wrench with ⅞ and ⅝ in socket

Assembly Procedure



Verify pole ID on crossarm matches ID of pole.

Note: Each crossarm is factory assembled for a specific position on poletop section to ensure correct aiming. Top side of crossarm is labeled with crossarm's position number. Example: Position 1 is installed on first position from top of poletop section.

1

Position crossarm near poletop, and feed crossarm wire harness through hole in center of poletop plate.

Route wire harness for crossarms 1–3 to top of pole.

Route wire harness for crossarms 4–7 to handhole below crossarm position 5.

2

Position crossarm as shown below.



Ensure crossarm wire harness is not pinched between mating plates.

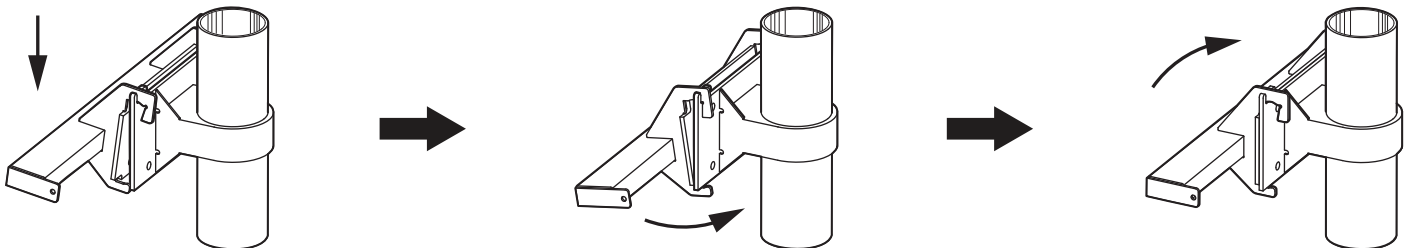
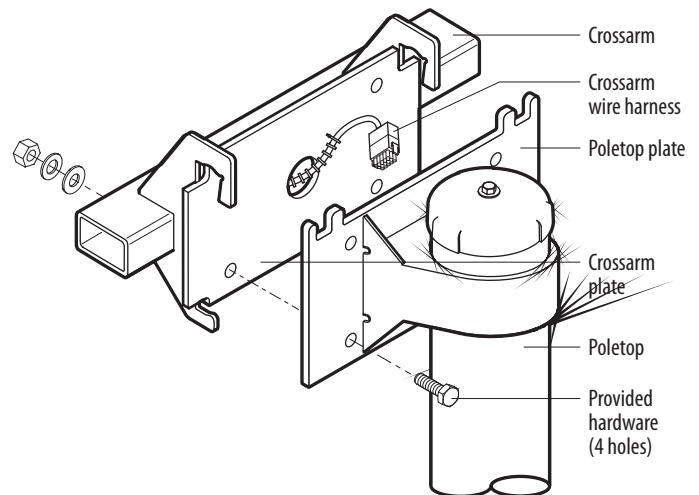

Bolt-on Crossarms

- 3** Install bolts through plates with threads away from pole. Place direct tension indicating (DTI) washer next, with flat surface (orange material) against plate, and bumps facing out toward nut. Place flat washer next, followed by nut. Small ID markings on nut must face out to allow proper identification of nut.

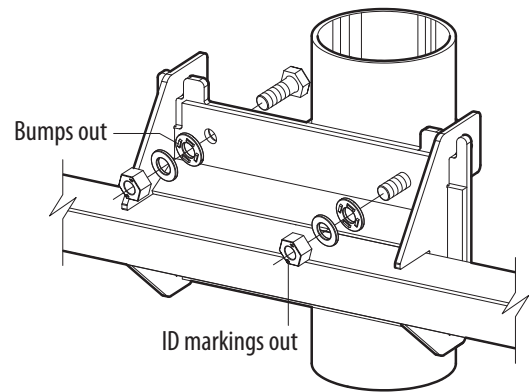

- 4** Snug all nuts. Using supplied 1½ in wrench, tighten each nut until plates are in firm contact. Follow tightening sequence shown.

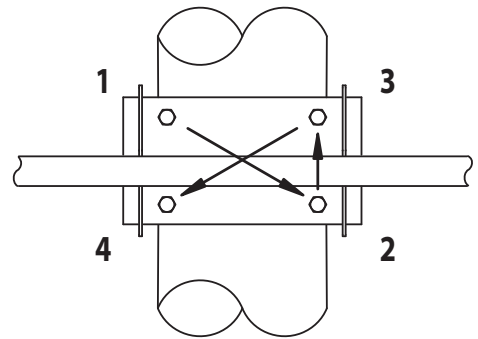

- 5** Using supplied breaker bar, 1½ in socket, extension, and wrench, tighten each nut until orange extrusion appears from at least three bumps.

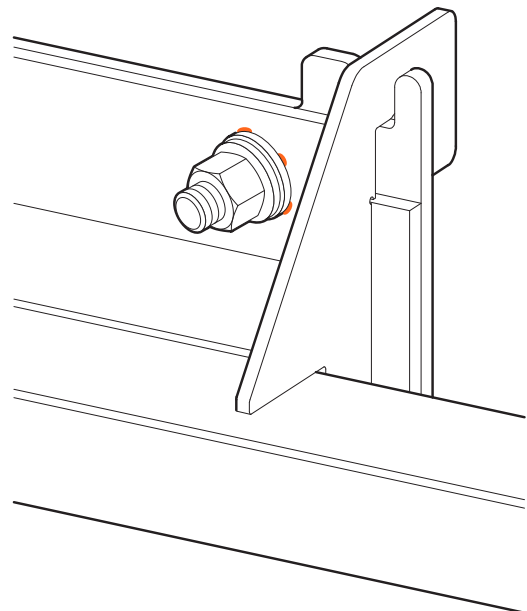

Bolt-on Crossarms

6

Repeat steps 1–5 for remaining crossarms.



Do not reuse structural fasteners. Discard if removed or loosened after tightening.



Refer to the *Field Aiming Diagram* to determine if a pole requires spreader bars. If so, spreader bars are bundled together and marked with the pole ID. Additionally, the pole crossarms are stenciled indicating which tabs to use. Crossarms are joined in groups of two or three with the greatest grouping on top; do not form other groupings.

7

Install spreader bars with $\frac{3}{8}$ in fasteners at the locations marked on each crossarm. Torque to 25 ft•lb (34 N•m).

Spreader bars may come in two sizes, 30½ in (775 mm) and 60 in (1524 mm). Always install longer bars to upper three crossarms.



See *Installation Instructions: Platform, Climbing Steps, and Safety Cable*, if your project includes these items.

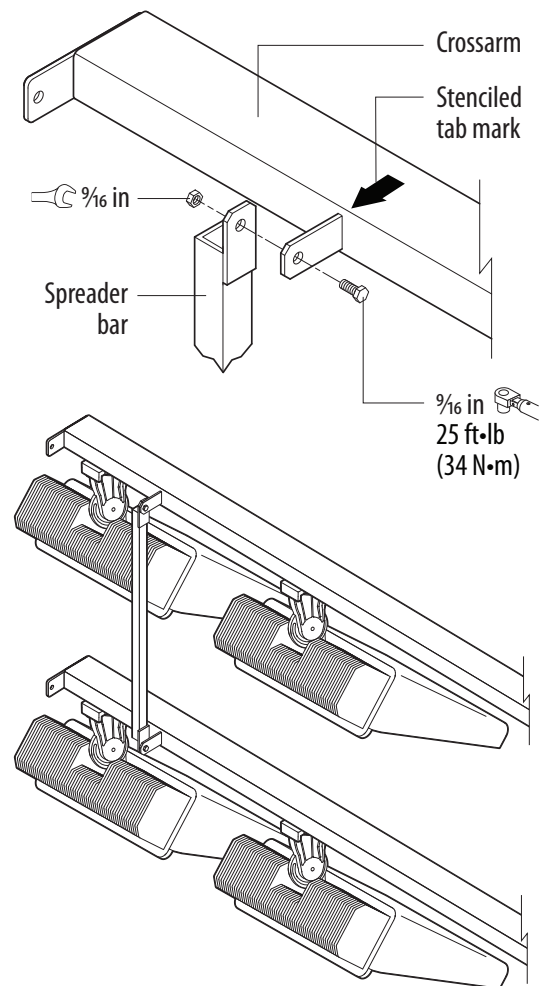

Electrical Components Enclosure

Overview

The electrical components enclosure is factory-wired and tested. Built-in hardware allows for easy attachment to the galvanized steel pole. Quick-connect plug-ins ensure trouble-free connection to the poletop luminaire assembly via the wire harness.

Tools/Materials Needed

Musco Supplied

1/16 in wrench

5/32 in hex key

Contractor Supplied

Phillips-head screwdriver

Standard screwdriver

Assembly Procedure



Verify pole ID on electrical components enclosure matches pole location on *Field Aiming Diagram*.



Caution

Electrical components enclosures are heavy.

Electrical components enclosure may weigh up to 65 lb (30 kg). Lift carefully with two people to avoid injury.

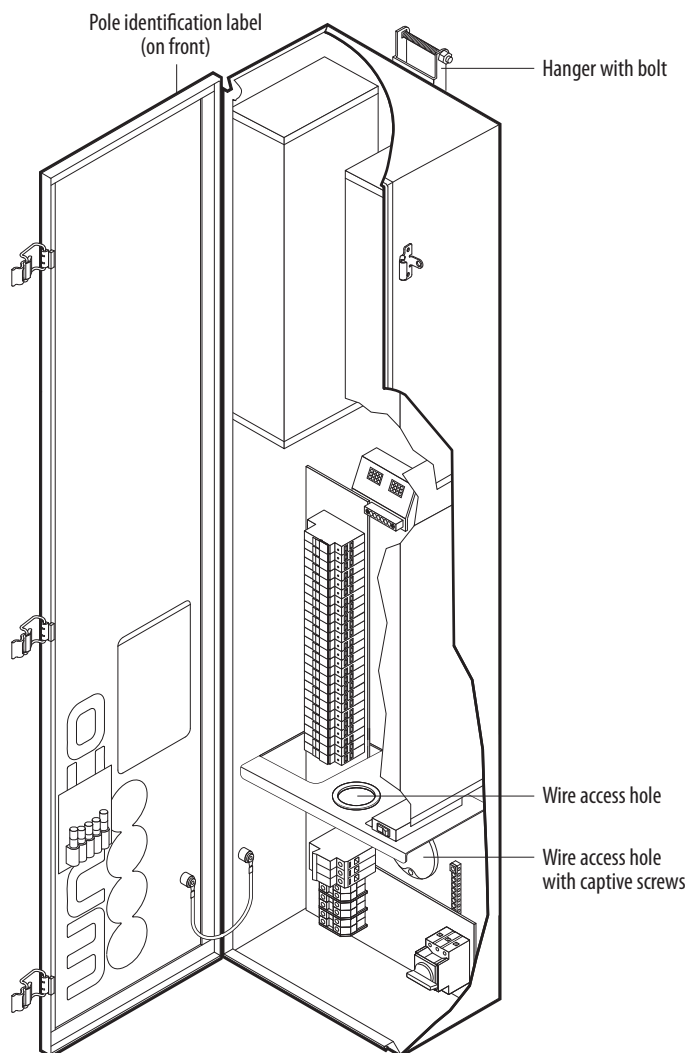

Electrical Components Enclosure

1 Mount bottom enclosure on pole. Align wire access hole with hub. Tighten captive screws using Phillips-head screwdriver. Tighten hanger bolt with $\frac{1}{16}$ in wrench.

2 Mount middle and/or top enclosures. Align access hole with hub and slide box onto hanger bracket. Tighten hanger bolt with $\frac{1}{16}$ in wrench.

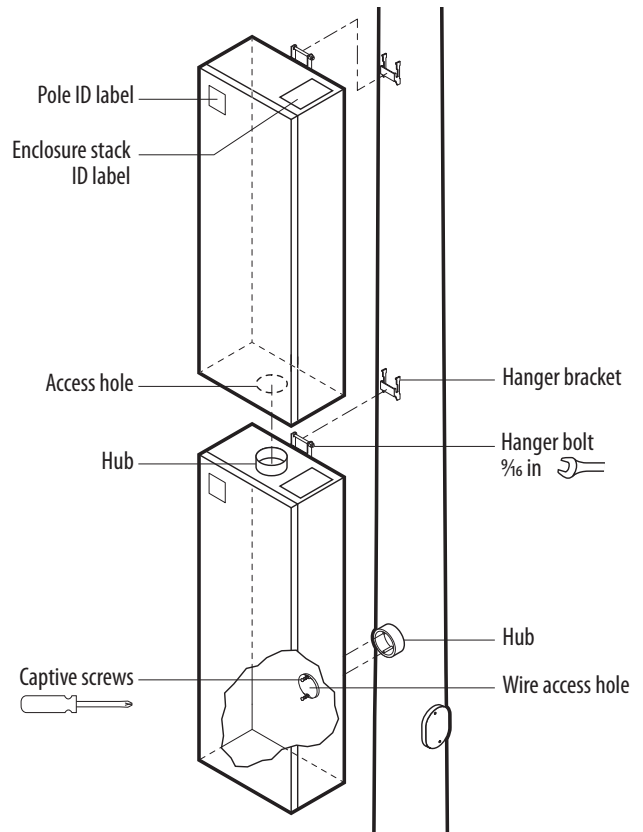

 Only qualified personnel may perform wiring. Route wires as shown, but leave the final connections for your electrician. See section *Connecting to Supply Wiring*.

3 Route driver harnesses from top and middle enclosures to bottom enclosure and plug into connector mounted in bracket.

4 Route equipment grounding conductor and enclosure harnesses from top and middle enclosures to bottom enclosure.

5 Repeat steps 1 – 4 for each stack.

 **Warning**
Risk of injury or property damage

Pole rotation may be required to assemble all components. Do not stand under pole when lifting. Steady pole with two people holding crossarms. Allow safe rotation when crossarms and electrical component enclosures will not contact ground or obstacles.

 **Caution**
Risk of injury or property damage

Pole may move without warning. Properly support pole before attaching luminaires.

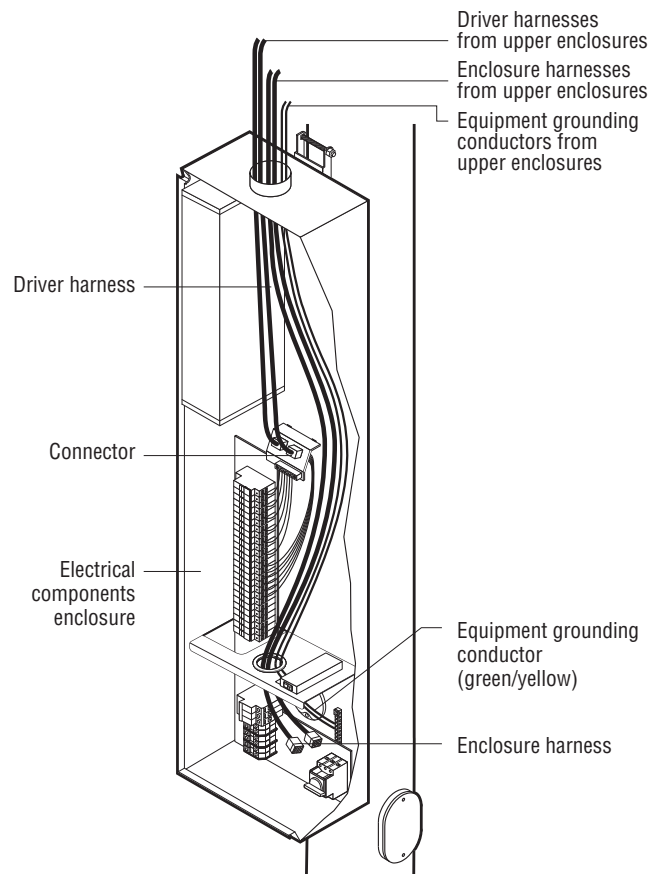

Electrical Components Enclosure

Note: Skip step 6 if drivers or controllers do not include communication.

6

Pull communication cables down from top and middle boxes and plug into driver or controller in enclosure below as shown.

Connecting Drivers

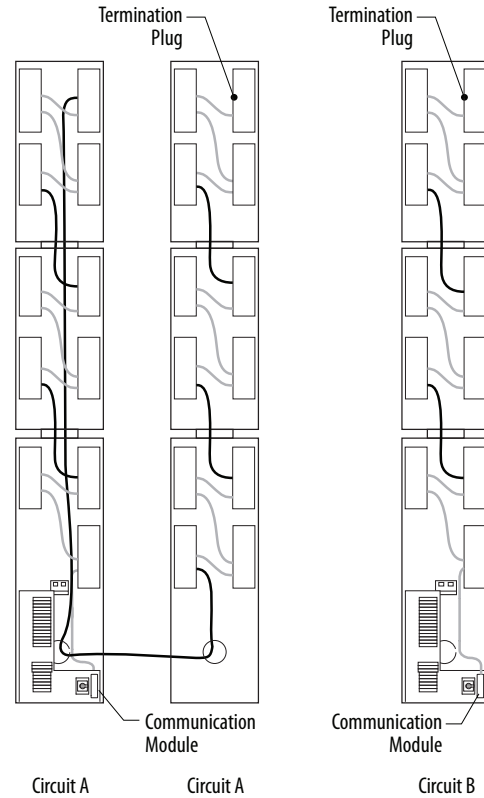

Connecting Controllers

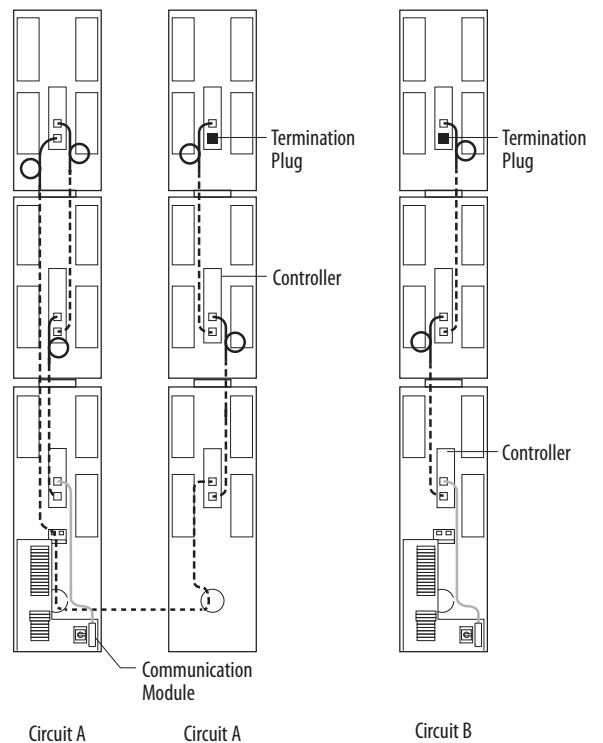

Electrical Components Enclosure

Note: Skip step 7 if emergency egress lighting dimming override relay board is not present.

7

Pull power monitoring cable from dimming override relay board in top and middle enclosures down to bottom enclosure and land black wire on terminal block M1 and blue/white wire on terminal block M2.

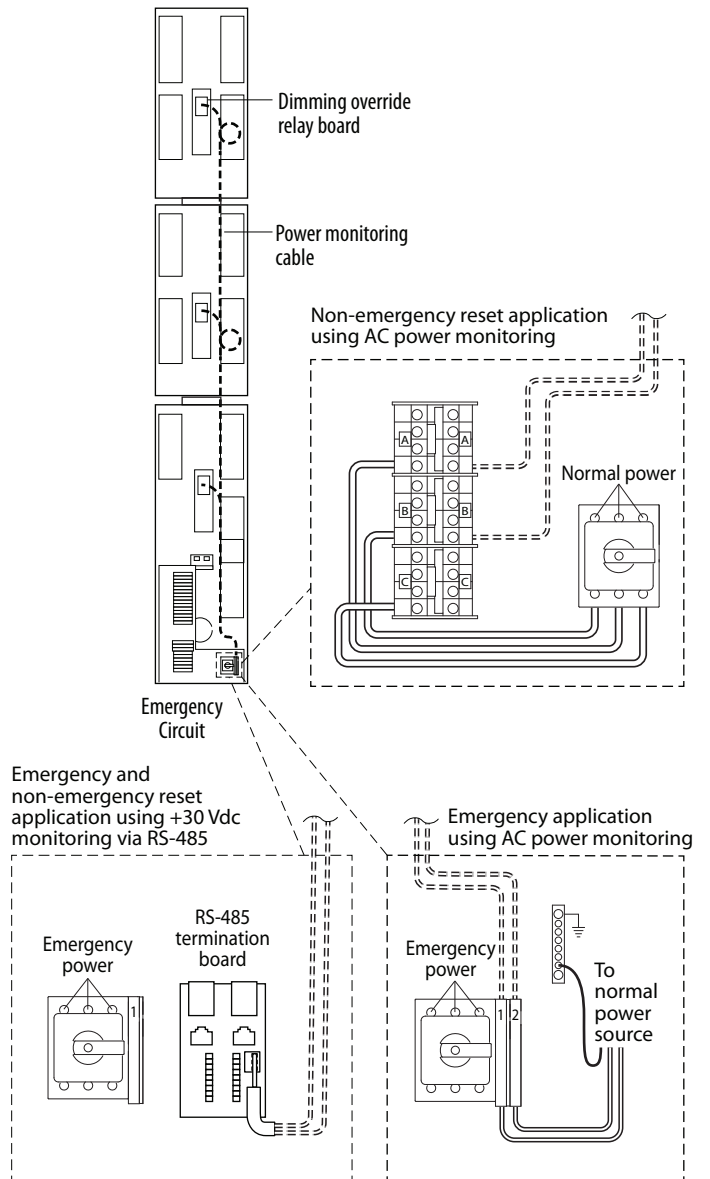

Electrical Components Enclosure

Note: Skip steps 8-9 if wireless antenna not present.

8

Using a $\frac{5}{32}$ in hex wrench mount the wireless antenna on the handhole provided. Route the coaxial cable down the pole into bottom electrical components enclosure.

9

Install the coaxial cable on the wireless radio located in the electrical components enclosure.

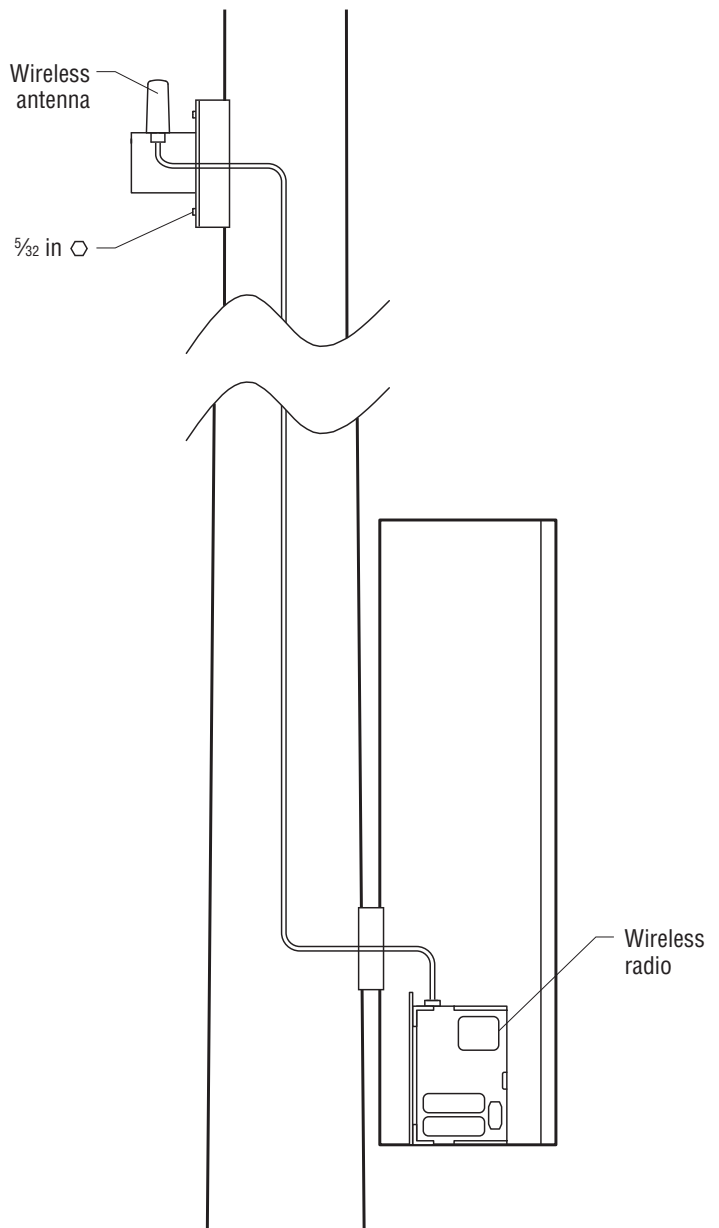

Wire Harness

Overview

The factory-built wire harness connects the electrical components enclosure to the poletop luminaire assembly.

Tools/Materials Needed

Musco Supplied

- 5/32 in hex key
- 5/16 in wrench

Contractor Supplied

- Fish tape
- Electrician's tape

Assembly Procedure

-  Verify pole ID on wire harness matches pole location on *Field Aiming Diagram*.
 - 1** Remove handhole covers using 5/32 in hex key. Remove polecap using 5/16 in wrench.
 - 2** Fish all pole wire harnesses between poletop and appropriate electrical components enclosure(s). Use lower handhole to access enclosure hubs. Ensure protective sleeve extends through access hub and tuck harnesses behind subpanel.
 - 3** Attach support grips at poletop and midpole (if present).
 - 4** Mate quick-connectors at poletop and inside electrical components enclosure(s). Match driver/luminaire IDs.
- Note: Each bolt-on crossarm has at least one separate harness. There is one additional spade connector for pole alignment beam.*
- 5** Replace handhole covers and polecap.

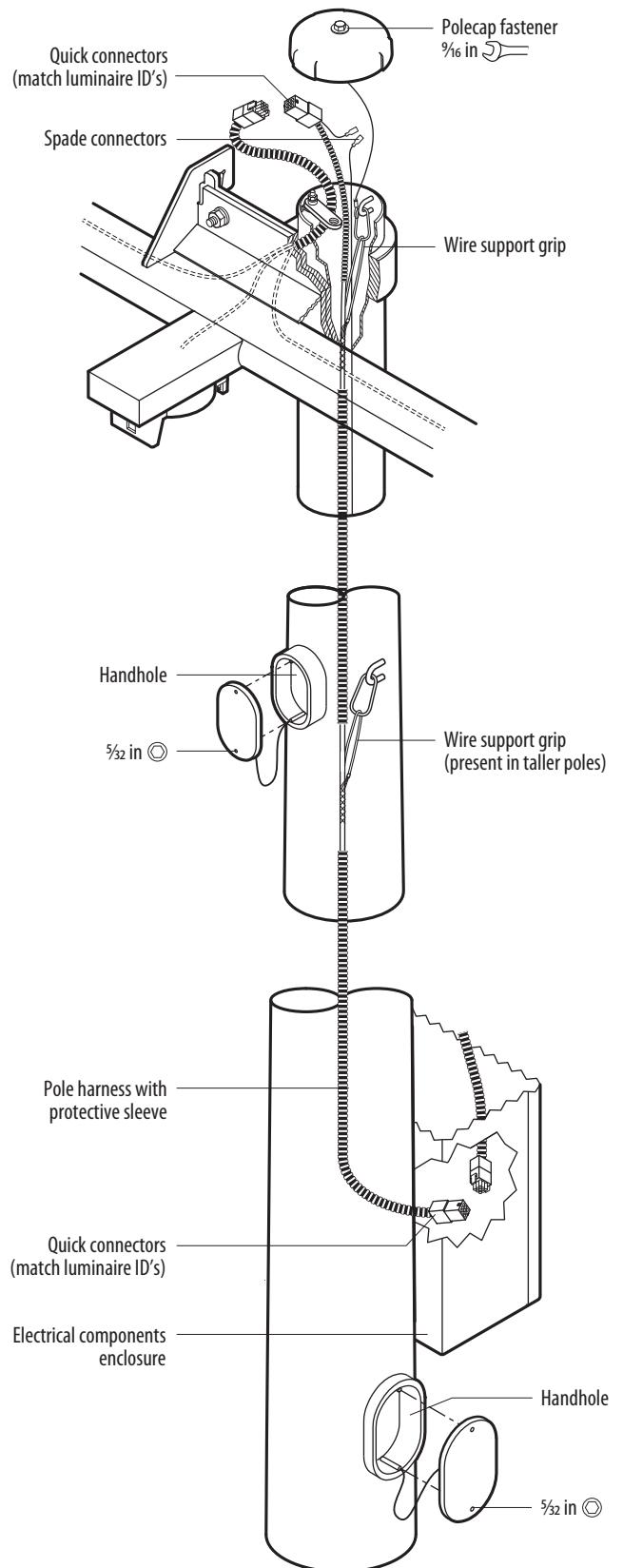

Luminaire Attachment

Overview

Luminaires are factory built and shipped in individual cartons. They are aimed in the factory and ready for installation. Do not disassemble knuckle.

Tools/Materials Needed

Musco Supplied

- 7/16 in ratcheting combination wrench

Note: Leave luminaires in box until ready to assemble. Keep protective cover on luminaire until ready to set pole. Do not leave luminaires unassembled from crossarm in wet conditions.

Contractor Supplied:

- Torque wrench with 7/16 in socket



Caution

No User Serviceable Parts

If protective lens glass is cracked or broken, luminaire must be replaced.

Luminaire light source is not replaceable; when light source reaches end of life entire luminaire must be replaced.



Contact your local Musco representative for maintenance or replacement.

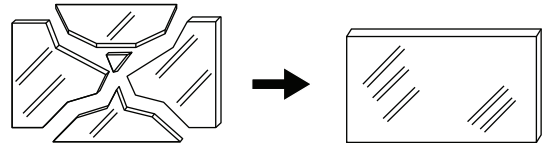
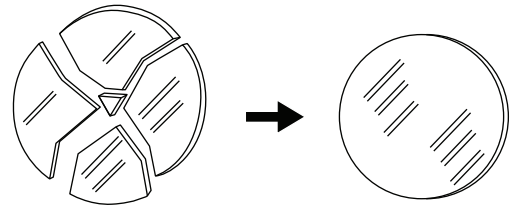

Luminaire Attachment

Assembly Procedure



Verify pole ID on luminaire cartons matches pole and location on *Field Aiming Diagram*.



Remove and discard orange protective caps from luminaire knuckle and mounting plate that cover electrical connections. Do not remove orange tag around captive bolts.

Note: The luminaire style may vary from what is shown.



Warning Risk of injury or property damage

Pole rotation may be required to assemble all components. Do not stand under pole when lifting. Steady pole with two people holding crossarms. Allow safe rotation when crossarms and electrical component enclosures will not contact ground or obstacles.



Caution Risk of injury or property damage

Pole may move without warning. Properly support pole before attaching luminaires.



Some luminaires may attach to auxiliary brackets, refer to *Installation Instructions: Auxiliary Bracket*.

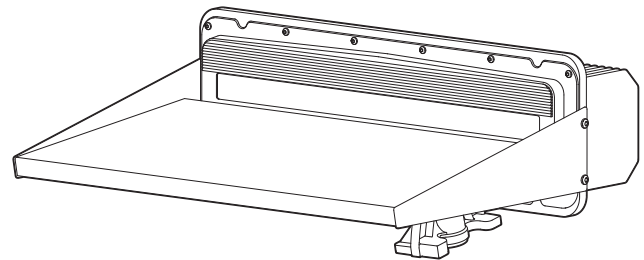
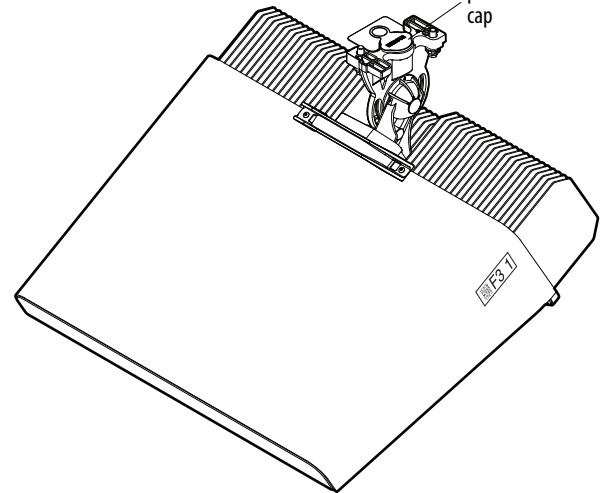
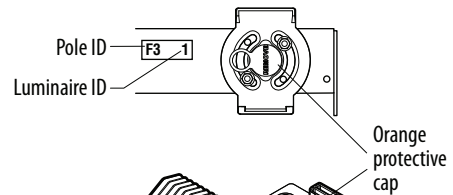

Luminaire Attachment

- Match luminaire ID to crossarm and install luminaire onto mounting plate. Use handle if present to lift luminaire. Insert back of knuckle into mounting plate and pivot into position.

Note: The luminaire style may vary from what is shown.

Luminaire	Weight
TLC-LED-350	25 lb (11 kg)
TLC-LED-400	40 lb (18 kg)
TLC-LED-550	25 lb (11 kg)
TLC-LED-550NR	38 lb (17 kg)
TLC-BT-575	34 lb (15 kg)
TLC-LED-600	40 lb (18 kg)
TLC-LED-900	40 lb (18 kg)
TLC-LED-900NB	114 lb (52 kg)
TLC-LED-1200	45 lb (20 kg)
TLC-LED-1400NB	106 lb (48 kg)
TLC-LED-1500	67 lb (30 kg)
TLC-RGB-A	40 lb (18 kg)
TLC-RGB-U	20 lb (9 kg)
TLC-RGBW	40 lb (18 kg)
TLC-TW	40 lb (18 kg)
TLC-BT-1500	67 lb (30 kg)
TLC-RGBW-U/ TLC-RGBA-U	40 lb (18 kg)

Caution
 Luminaire may be heavy. Improper lifting may damage luminaire or cause injury.
 Lift carefully with two people. Do not use visor to lift. Use handle if provided.

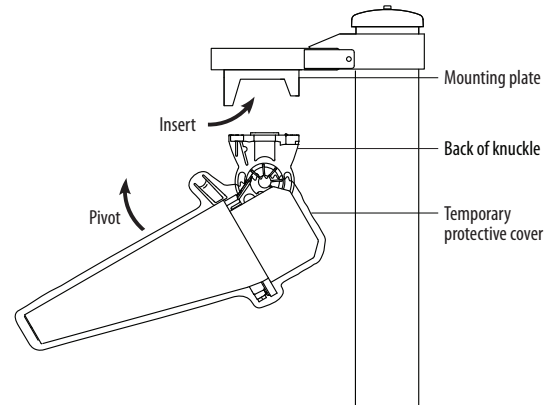

Or

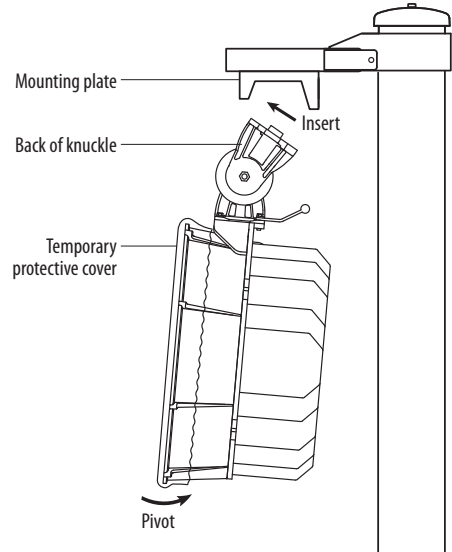

Or

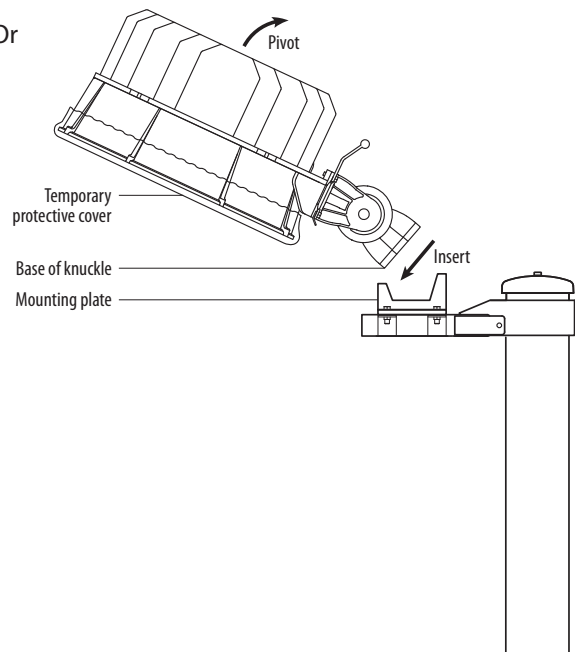

Luminaire Attachment

3 Attach luminaire retaining cable (if present). Route luminaire cable through crossarm anchor point, through luminaire block, and back through the block under the set screw. Luminaire attachment point will vary per luminaire design.

4 Using $\frac{7}{16}$ in socket and torque wrench, tighten cable set screw to 60 in·lb (6.8 N·m)

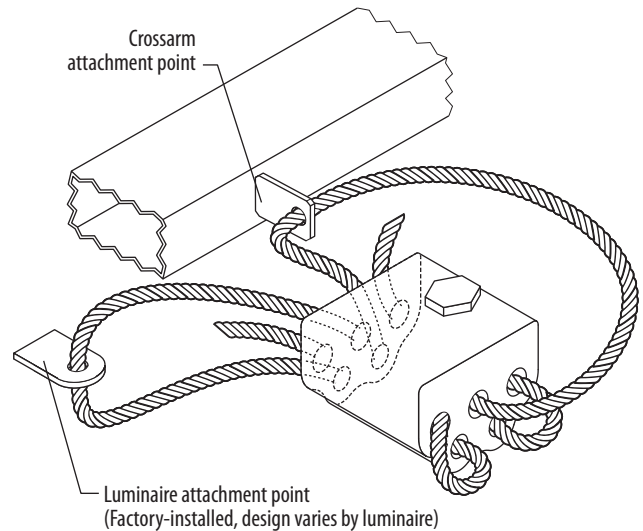

5 Using $\frac{7}{16}$ in socket and torque wrench, tighten captive mounting bolts to 20 ft·lb (27 N·m). Orange tag will break loose before all bolts are fully tight.



Warning
Luminaire may fall if bolts are not tight.

Do not remove tag before tightening bolts.



See *Installation Instructions: Climbing Steps and Safety Cable*, if your project includes these items.



Warning
Risk of injury or property damage

Pole rotation may be required to assemble all components. Do not stand under pole when lifting. Steady pole with two people holding crossarms. Allow safe rotation when crossarms and electrical component enclosures will not contact ground or obstacles.



Caution
Risk of injury or property damage

Pole may move without warning. Properly support pole before attaching luminaires.



If pole has auxiliary equipment, refer to *Installation Instructions: Auxiliary Bracket*.

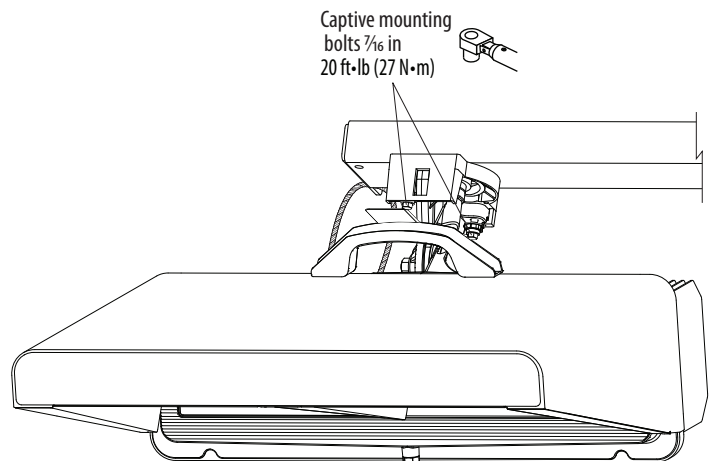

Pole Setting and Alignment

Overview

All luminaires are factory aimed to their exact position on the field. To ensure the proper pole orientation, a simple-to-use pole alignment beam completes the precision field aiming. The pole alignment beam is attached in the factory to each pole.

Tools/Materials Needed

Musco Supplied

- Field Aiming Diagram
- Pole rotator kit
- Dishwashing liquid (original Dawn®, ECOS® Pro, or DIAO™ brand)

Contractor Supplied

- Chalk or pencil
- Load-rated shackles as required
- Load-rated nylon slings as required
- Spray paint, chalk, or flags (to mark aiming points on field)
- Two 1½ ton chain come-alongs

Installation Procedure

 Verify pole ID matches precast concrete base and pole location on *Field Aiming Diagram*.

1 Mark aiming point(s) on field using *Field Aiming Diagram*. Poles may have individual aiming points or may all be aimed to a common point.

2 Lubricate concrete base with provided dishwashing liquid.

3 Attach pole rotator clamp approximately 12 in (300 mm) above bottom of pole. Wrap strap around pole and cinch tightly.

 **Caution**
Risk of injury or property damage.

Rotator bar can swing with force as pole is lifted. Do not install until you are ready to lower pole onto base (step 8).

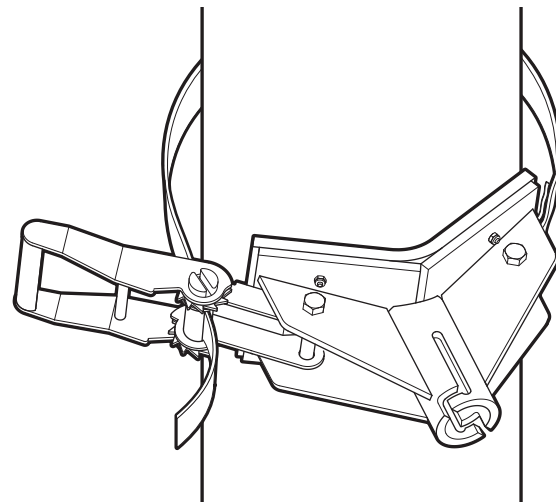
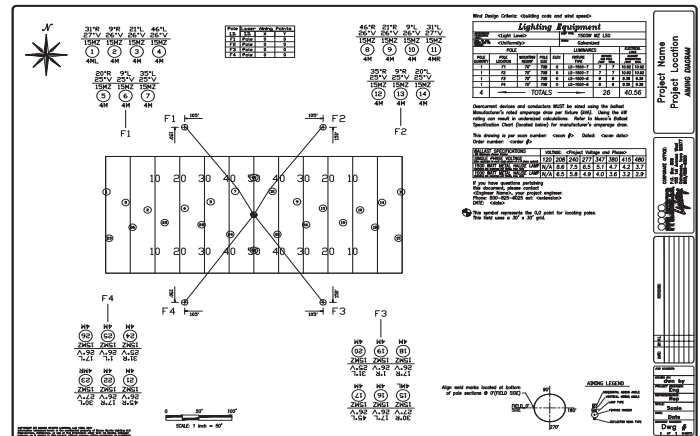

Pole Setting and Alignment

- 4** Remove temporary protective cover from luminaires (if present). Do not use knife.



Warning
Laser radiation hazard

Pole alignment beam is safe for viewing at a distance of three feet (one meter) or more. Do not look into beam from closer than three feet (one meter).

- 5** Turn on alignment beam and check. Device has toggle switch inside electrical components enclosure. For poles with platforms, alignment beam device has a rotary switch located on the back of the alignment device.

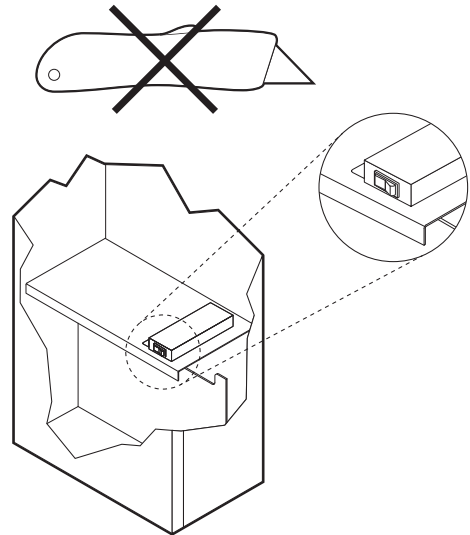

Warning
Improper rigging can cause pole sections to separate and fall.

Follow these instructions carefully. Do not choke pole or lift from crossarms.

- 6** Sling pole using this recommended method (see illustration). You must lift pole from lowest section. Friction between assembled sections will not hold pole together when lifting. To keep pole upright when lifting, ensure cradle point is above pole center of gravity. Ensure cradle point is free and will not cinch around pole or snag on hardware or components during lifting.

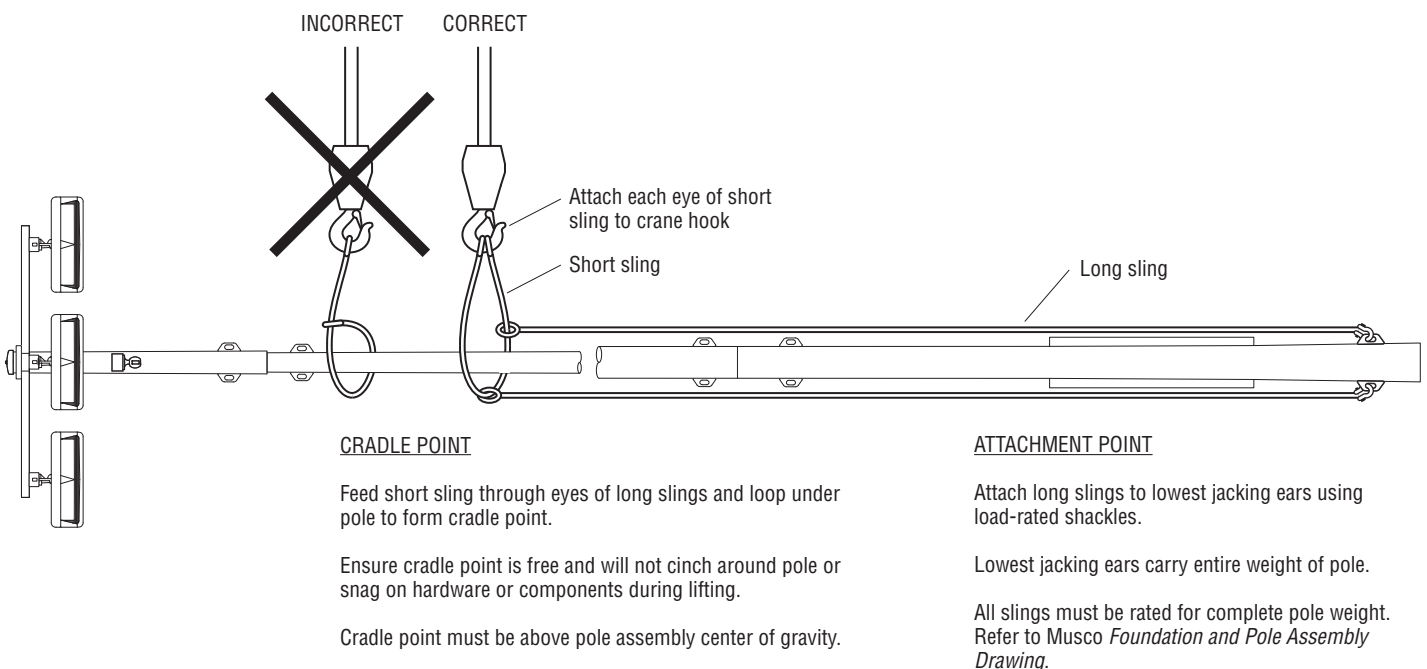

Pole Setting and Alignment



Warning Crushing hazard

Pole can rotate with force, causing injury.

Do not stand under pole when lifting. Steady pole with two people holding crossarms. Allow pole to safely rotate around when it is high enough for crossarms and electrical components enclosures to clear the ground.

7

Lift pole. Use care to avoid dragging bottom of pole. Keep crane head below crossarms.



Watch for these signs to ensure you are lifting pole properly:

- Short sling slides freely up the pole and long slings tighten.
- Top of pole rises first.
- Short sling does not choke or snag on pole.
- Lowest jacking ears carry entire weight of pole.



If project includes anchor bolt foundations or baseplate poles refer to *Installation Instructions: Baseplate Poles*.

8

When pole is suspended, insert rotator bar to clamp and turn to lock in place. Guide pole into position over base using rotator bar and lower onto base. Do not allow pole to seat on base until it is properly aimed (step 9). Pole should rotate with reasonable force applied to bar, but not freely.



Warning Pinching hazard

Keep hands clear when setting pole on concrete base.

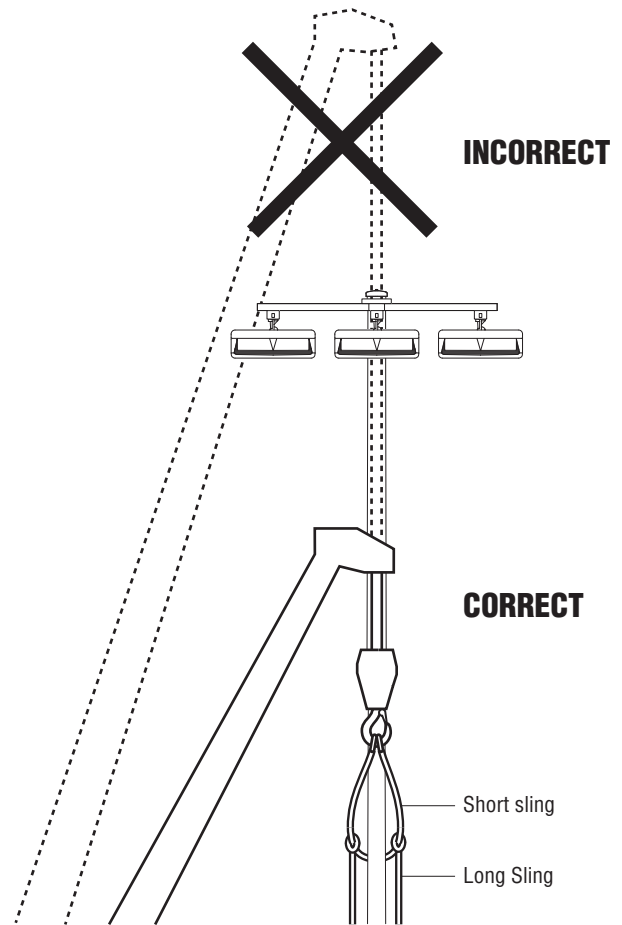

Pole Setting and Alignment

9 Align pole using alignment beam. Device projects a narrow vertical beam of light that is only visible when you are aligned with it. This step requires two people.

Person A: Stand on field aiming point and look at pole alignment device. It is mounted below lowest crossarm. Walk parallel to crossarms until you see beam. Signal person B to rotate pole left or right until beam aligns with aiming point. Beam may be visible, however when pole is aligned, you will see a bright flash as you stand directly on aiming point.

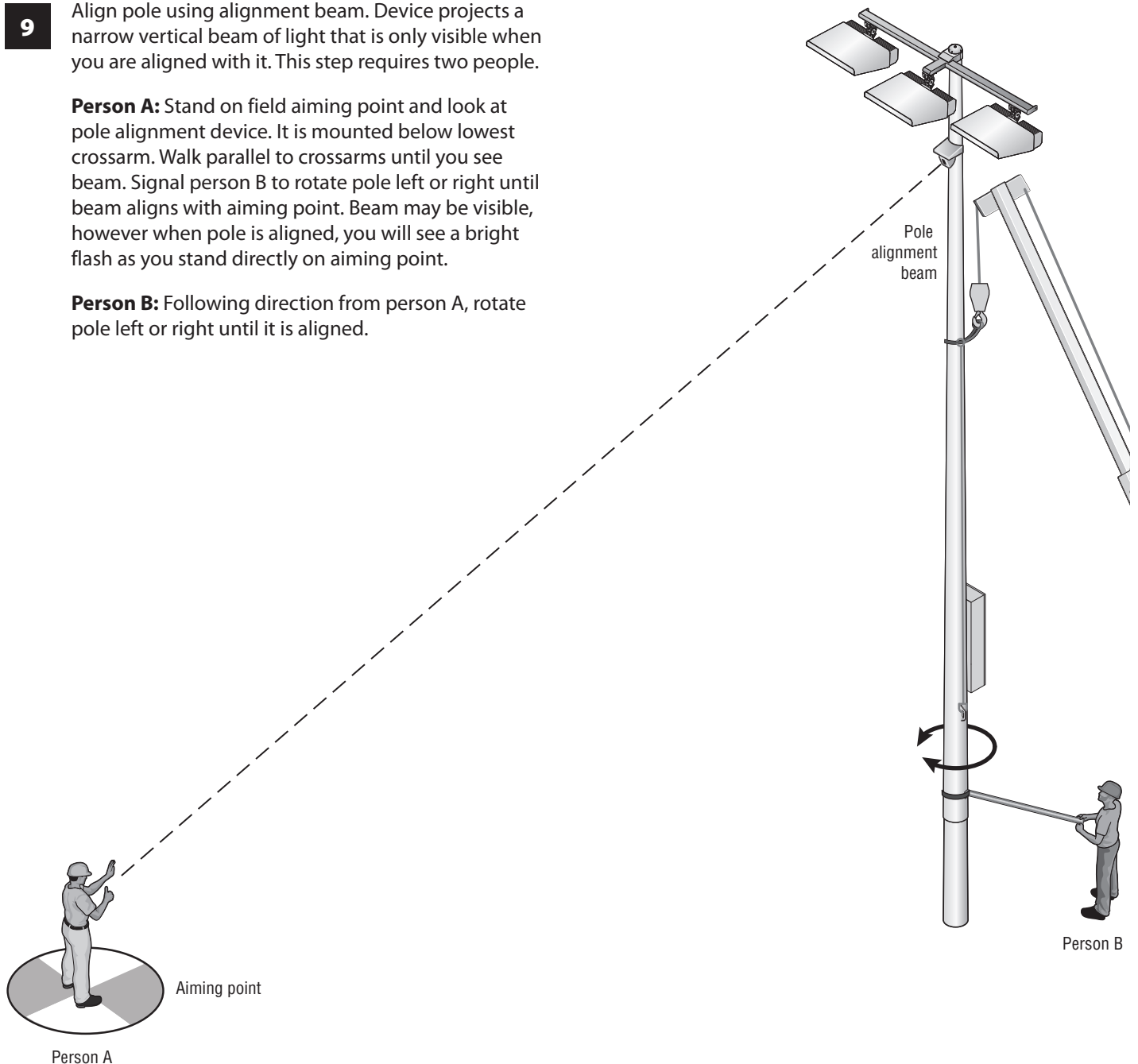

Person B: Following direction from person A, rotate pole left or right until it is aligned.



Warning **Laser radiation hazard**

Pole alignment beam is safe for viewing at a distance of three feet (one meter) or more. Do not look into beam from closer than three feet (one meter). Do not use binoculars, camera, or telescope to view beam from any distance. Locator beam is a class 2M laser device. Wavelength: 635-660 nm, laser power for classification: <1 mW continuous, divergence: <1.5 mrad x 1 rad. Using alignment beam in a manner other than as described here may result in hazardous exposure. Do not modify, dismantle, or attempt to repair.

Pole Setting and Alignment

- 10** Once pole is aligned, use level to draw a thin vertical alignment mark on pole and concrete base. Use mark to verify alignment is maintained while lowering pole (step 11) and jacking onto base (step 12).
 - 11** Lower pole into position. Hold pole rotator bar to maintain alignment until pole seats on base. Remove rotator bar and clamp.
 - 12** Insert provided steel bar through base. Wrap provided chain around base below steel bar. Attach two 1½ ton come-alongs to jacking ears. To avoid twisting, attach come-alongs to provided chain directly below jacking ears. If ears align parallel with steel bar, do not use chain. Pull pole down onto base, keeping marks aligned. Ensure minimum overlap per Musco *Foundation and Pole Assembly Drawing*.
-  If pole seats out of alignment, contact Musco to request separating tools. See *Installation Instructions: Separating Steel Pole from Concrete Base*.
-  If pole has climbing steps and safety cable, see *Installation Instructions: Climbing Steps and Safety Cable* for cable tensioning instructions.

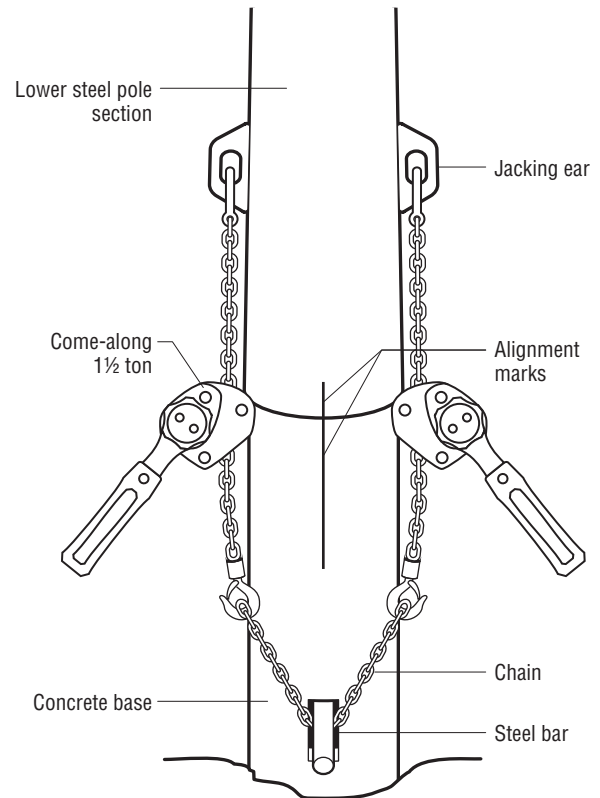

Connecting to Supply Wiring

Overview

The final step of installation is connecting the supply wiring at the subpanel. Terminals for phase wires and neutral (if used), disconnect switch with lockout, and equipment ground bar are provided on the subpanel in the electrical components enclosure. If there are multiple circuits on the pole, a disconnect is provided for each circuit. This may be on a separate subpanel in another enclosure. The lighting system uses an integrated lightning ground embedded in the precast concrete base. Depending on foundation design and/or soil conditions, a supplemental grounding electrode may be required.

Tools/Materials Needed

Musco Supplied

- 3/16 in hex key (ground bar)
- 5/16 in hex key (bonding terminal inside handhole)
- 5/32 in hex key (handhole covers)
- 5 mm hex key (125 A disconnect terminals)
- Equipment bonding jumper

Contractor Supplied

- Underground wiring and conduit
- Main power disconnect and distribution panel(s)
- Standard screwdriver
- 3 m (10 ft) stepladder or small line truck

Installation Procedure

 Musco *Control System Summary* or *Field Aiming Diagram* provides electrical loading information needed to size wire and switchgear.

Musco provides instructions for installing Control-Link™ control system or lighting contactor cabinet when these items are part of your project.

1 If pole has multiple stacks on the same electrical circuit, route lower loads from second stack to distribution lugs on main subpanel.

Route all power leads for lighting equipment to appropriate subpanel locations.

2 Connect equipment grounding conductors (green/yellow) from each upper enclosure to equipment ground bar in bottom enclosure. If pole has multiple stacks, connect bonding jumper from stack one.

Tighten lugs using 3/16 in hex key.

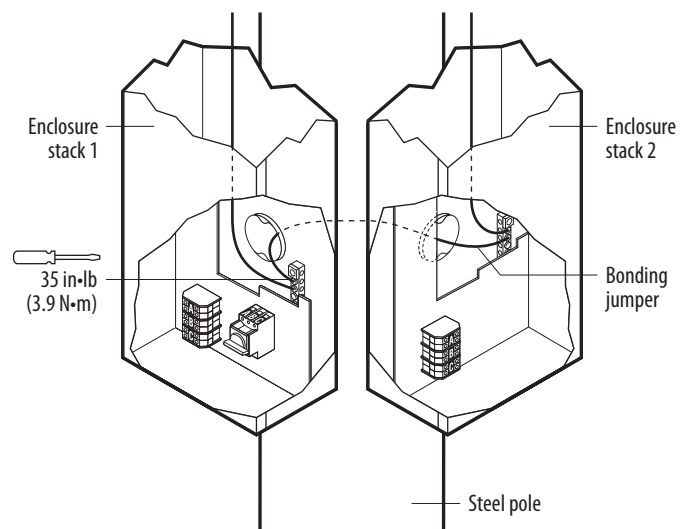
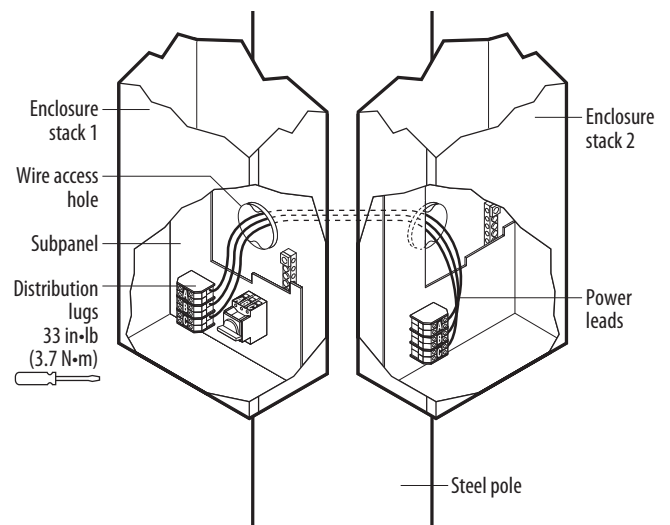

Connecting to Supply Wiring

- 3** Remove handhole cover using $\frac{5}{32}$ in hex key. Rout supply wiring through access hub into electrical components enclosure.
- 4** Connect insulated equipment grounding conductor (supply) to ground bar. Tighten lug using $\frac{3}{16}$ in hex key.
-  Disconnect is rated for copper wire only. Contact Musco for adaptor or use UL Listed adaptor for aluminum supply wire.
- 5** Connect phase wires (supply) to disconnect switch. Tighten lugs using standard screwdriver (45 A disconnect) or 5 mm hex key (125 A disconnect). Connect neutral wire (if used) to distribution lug. Tighten lug using standard screwdriver.

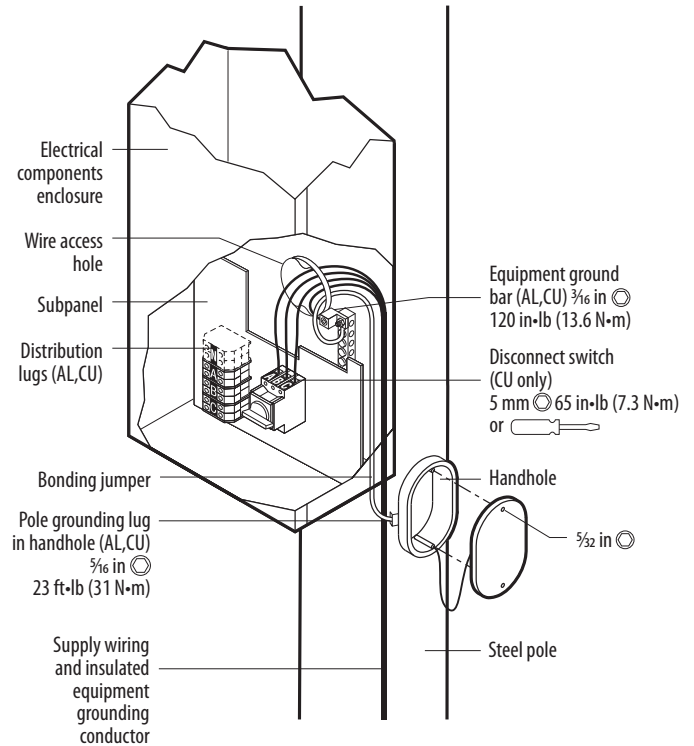

Disconnect Wiring Information

Disconnect Rating	Terminal	Wire Size Range	Strip Length	Torque
45 A	L	12–3 AWG (4–25 mm ²)*	0.63 in (16 mm)	25 in-lb (2.8 N-m)
	N	16–4 AWG (1.5–25 mm ²)*	0.56 in (14 mm)	27 in-lb (3.1 N-m)
	G	14–2/0 AWG (2.5–50 mm ²)**	NA	120 in-lb (13.6 N-m)
125 A	L	10–2 AWG (6–35 mm ²)*	0.63 in (16 mm)	50 in-lb (5.6 N-m)
	N	1–2/0 AWG (40–50 mm ²)*	0.63 in (16 mm)	65 in-lb (7.3 N-m)
	G	14–2/0 AWG (2.5–50 mm ²)**	NA	120 in-lb (13.6 N-m)

*Stranded cable, single conductor, copper only

**Stranded cable, single conductor, copper or aluminum

Connecting to Supply Wiring

- 6** Route provided equipment bonding jumper (green/yellow) through access hub to pole grounding lug inside handhole. Tighten lug using $\frac{5}{16}$ in hex key.
- 7** Ensure all handhole covers are installed and electrical components enclosure is closed and latched.
-  If your project includes a supplemental grounding electrode kit, follow instructions in kit for installing electrode.



Warning Risk of electric shock.

Terminate equipment grounding conductor at equipment ground bar in electrical components enclosure.



Warning Lightning hazard.

For poles located near metal fences, metal bleachers, or other metal structures, bond structures to pole ground to maintain equal electrical potential.

Note: Skip step 8 if no emergency egress lighting is present.

- 8** Route cable for normal power to adjacent enclosure stack. Connect black wire and blue/white wire to any two active terminals A, B, C, or neutral, if present, and green wire to ground bar.

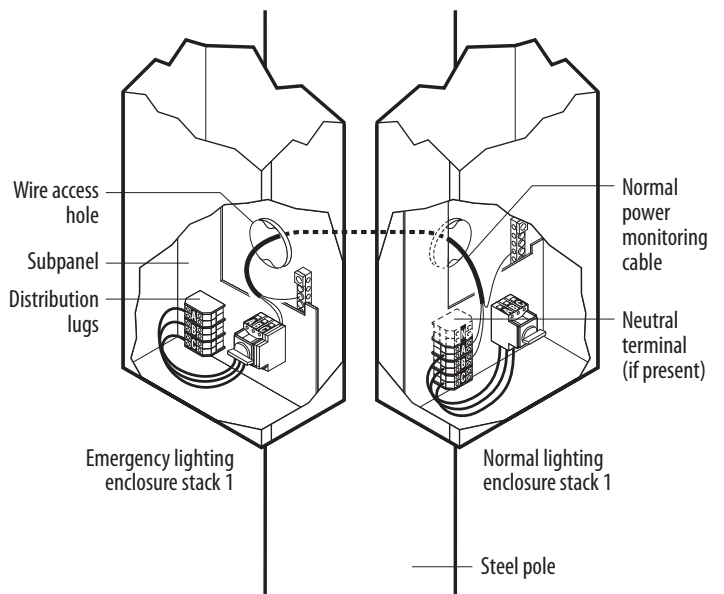



www.musco.com

Musco Light-Structure System™ product referenced or shown may be protected by one or more of the patents listed here: www.musco.com/patents/lss_m-1917.pdf.