



CITY OF KNOXVILLE
 OFFICE OF THE PURCHASING AGENT
 P.O. BOX 1631
 400 MAIN ST., ROOM 667
 KNOXVILLE, TN 37901

SEALED BID

THIS IS NOT AN ORDER

DATE: 10/19/2017 PAGE 1 Of 1

DOCUMENT NUMBER: **473666**

READ ALL INSTRUCTIONS AND CONDITIONS ON ATTACHED PAGES BEFORE BIDDING. BID ON THIS FORM ONLY. BID PRICE ON ITEMS LISTED OR EQUAL. NO BID RECEIVED AFTER CLOSING HOUR WILL BE ACCEPTED.

****ALL PRICES TO INCLUDE TRANSPORTATION CHARGES & NET TERMS UNLESS STATED OTHERWISE ****

Merchandise to be delivered to : Department of Engineering Signal Shop
 1025 Elm Street
 Attn: Allen Arnett
 Knoxville TN 37921

BID will be received at: Office of the Purchasing Agent, Room 667, 400 Main St., Knoxville, TN 37902, until 11/07/2017 11:00:00 AM

ENVELOPE TO BE SEALED AND MARKED: **TRAFFIC SIGNAL HOUSINGS**

Special Instructions:
 The quoted price must be in effect for a period of one year with the option to renew for two additional one year periods. The renewal will be based upon the approval of both parties. Direct all questions to jtucker@knoxvilletn.gov.

No.	Quantity	Description	Brand	Unit	Unit Price	Total	Applicable Discount
1	250 Each	Fixed Price Agreement (1 year, renewable annually for two additional years) for 3-Section Signal Housing according to the attached specifications.					

IMPORTANT - State Merchandise

Delivery Date Here: _____

Buyer Name: Tucker, James
 Phone: 865-215-2064
 Fax: (865) 215-2277
 Email: jtucker@knoxvilletn.gov

 (Company Name)

 (Authorized Signature)

 (Print Signed Name)

 (Phone Number)

 (Email Address)

**CITY OF KNOXVILLE
INVITATION TO BID**

TRAFFIC SIGNAL HOUSINGS

Sealed bids, invited by the City of Knoxville, will be received by the Purchasing Agent of the City of Knoxville, in Room 667-674, City County Building; 400 Main Avenue; Knoxville, Tennessee, until 11:00:00 a.m. (Eastern Time) on November 7, 2017, at which time they will be opened and publicly read aloud and a contract awarded as soon thereafter as practicable.

BID SUBMISSION REQUIREMENTS

Bidders must furnish the following information in writing with their submission:

1. Bid Form showing bidder's name, address, quoted price, business license number, date of expiration of business license. A copy of the bidder's current business license may be submitted in lieu of providing the license expiration date.
2. Non-Collusion Affidavit
3. Iran Divestment Act Certification of Noninclusion
4. Option A or B from the Diversity Business Enterprise packet

INVITATION TO BID – INSTRUCTIONS AND CONDITIONS

1. Sealed bids will be received by the Purchasing Agent of the City of Knoxville in Room 667-674, City/County Building; 400 Main Avenue; Knoxville, Tennessee 37902 until November 7, 2017 at 11:00:00 a.m., at which time they will be publicly opened and read aloud and the contract awarded as soon as practicable. **No bid will be received or accepted after the above-specified time for the opening of bids.** Bids that arrive late due to the fault of U. S. Postal Service, United Parcel Service, DHL, FEDEX, any delivery/courier service, or any other carrier of any sort are still considered late and shall not be accepted by the City. Such bids shall remain unopened and will be returned to the submitting entity upon request.
2. The City of Knoxville reserves the right to reject any or all bids, to accept or reject any items thereon, to waive technicalities or informalities, to split orders if in the best interest of the City, to evaluate bids by various criteria, and to accept any bid which, in its opinion, may be for the best interest of the City.
3. Included in the Invitation to Bid is an affidavit in proof that the undersigned has not entered into any collusion with any person in respect to this bid or any other bid. The Bidder will be required to execute and submit this affidavit with the sealed bid.
4. Each bid must be submitted in a sealed envelope, addressed to the Purchasing Agent, City of Knoxville, Room 667-674, City/County Building, 400 Main Street, Knoxville, Tennessee, 37902. Each sealed envelope containing a bid must be plainly marked on the outside as: "Traffic Signal Housings."
5. **NO CONTACT POLICY:** After the posting of this solicitation to the Purchasing Division's website, any contact initiated by any proposer with any City of Knoxville representative concerning this proposal

is strictly prohibited, unless such contact is made with the Purchasing Division representative listed herein or with said representative's authorization. Any unauthorized contact may cause the disqualification of the proposer from this procurement transaction.

6. **INCLEMENT WEATHER:** During periods of inclement weather, the Purchasing Division will enact the following procedures with regard to solicitations and weather delays:
 - If City offices are closed due to inclement weather on the date that bids/proposals/qualifications/letters of interest are due into the Purchasing Office, all solicitations due that same day will be moved to the next operational business day.
 - The City of Knoxville shall not be liable for any commercial carrier's decision regarding deliveries during inclement weather.
7. All bids must be made on the Bid Form supplied with the contract documents, and no interlineations, excisions, or special conditions shall be made or included in the Bid Evaluation Sheet by the Bidder. **Any bid on which there is an alteration of or departure from the Bid Form may be considered irregular and may be rejected.** All bids must be signed in full by the Bidder or Bidders in their business name or style when submitted and must show his or their complete address.
8. No bidder may withdraw his bid for a period of 60 days after the actual date of the opening thereof.
9. Prior to submitting their bids, bidders are to be registered with the Purchasing Division by setting up a Vendor Self-Service Account. Instructions for registering on-line are available at www.knoxvilletn.gov/purchasing.
10. **Bid submissions from un-registered bidders may be rejected.**
11. Payment for completed services delivered to and accepted by the City shall be at the contract price.
12. State makes or brand on each item. If quoting on other than the make, model, or brand specified, the manufacturer's name and catalog number must be given, along with warranty information and detailed specifications. Because the City is committed to environmentally sound practices, brands are expected to be procured with environmental responsibility in mind.
13. Time of delivery is part of the consideration and must be stated in definite terms; time of delivery is guaranteed by the bidder and must be adhered to upon award. If time varies on different items, the bidder shall so state.
14. All quotations must be signed with the firm name and by a responsible officer or employee. Obligations assumed by such signature must be fulfilled.
15. Samples of items, when required, must be furnished free of expense to the City and if not called for within fifteen (15) days from the date of bid opening, same will be disposed of in a manner deemed to be in the best interest of the City. Items shipped as a result of an Agreement to purchase (Purchase Order) must match the sample provided with Vendor's bid submission. The City of Knoxville will be the sole judge as to whether or not the shipped items match said supplied sample, and the City's decision will be final. Should shipped items not, in the City's judgment, be as represented by the sample provided, Vendor shall pay the City in full for all costs associated with returning shipped items to the Vendor. No restocking fee or other fees will be assessed against the City of Knoxville.
16. Bidders shall verify bids before submission, as bids cannot be withdrawn or corrected after being opened. Bids will be evaluated by unit price.

17. If federal excise tax applies, show amount of same and deduct. Bear in mind that the City is exempt from Tennessee sales tax.
18. Prices are considered FOB Knoxville unless otherwise stated in the Invitation to Bid.
19. By execution and delivery of a bid submission, the bidder agrees that any additional terms and conditions, whether submitted to the City purposely or inadvertently, shall have no force or effect.
20. Bidders must comply with the President's Executive Orders No. 11246 and 11375 which prohibit discrimination in employment regarding race, color, religion, sex or national origin. Bidders must not maintain or provide for their employees any facilities that are segregated on the basis of race, color, religion or national origin. Bidders must also comply with Title VI of the Civil Rights Act of 1964, Copeland Anti-Kick Back Act, the Contract Work Hours and Safety Standard Act, Section 402 of the Vietnam Veterans Adjustment Act of 1974 and Section 503 of the Rehabilitation Act of 1973, all of which are herein incorporated by reference.
21. All bidders must comply with Title VI of the Civil Rights Act of 1964, as codified in 42 U.S.C. 2000d. The successful bidder must follow Title VI guidelines in all areas including hiring practices, open facilities, insurance, and wages. The City of Knoxville reserves the right to review all compliance records by a contract compliance officer designated by the City.
22. No interpretation of the meaning of the plans, specifications, or other pre-bid documents will be made to any bidder orally. Each request for such interpretation should be in writing addressed to **James Tucker, Senior Buyer** for the City of Knoxville, 400 Main Street, Room 667, Knoxville, TN 37902, or emailed to him at jtucker@knoxvilletn.gov. To be given consideration, such requests/questions must be received at least five (5) business days prior to the date fixed for the opening of bids. Any and all such interpretations and any supplemental instructions will be in the form of written addenda to the specifications which, if issued, will be posted to the City's website at www.knoxvilletn.gov/purchasing. Submitting organizations are strongly encouraged to view this website often to see if addenda are posted. Failure of any bidder to receive such addendum or interpretation shall not relieve such Bidder from any obligation under his bid as submitted. All addenda so issued shall become part of the Contract Documents.
23. Attention of all bidders is directed to the set off provision contained in Article II, Section 24-33, entitled, "Debts owed by persons receiving payments other than salary", and Section 2-1049 entitled "Receipt of benefits from City contracts by council members, employees, and officers of the City" of the Code of the City of Knoxville.
24. Before a Purchase Order is issued, the submitting entity, if selected, **must** provide the City Purchasing Division with a copy of its valid business license **or** with an affidavit explaining why it is exempt from the business licensure requirements of the city or county in which it is headquartered. If a contract is signed, the contractor's business license shall be kept current throughout the duration of the contract, and the contractor shall inform the City of changes in its business name or location. Any Agreement to purchase resulting from this Invitation to Bid shall be governed by and construed in accordance with the substantive laws of the State of Tennessee and its conflict of laws provisions. Venue for any action arising between the City and the Vendor from the Agreement shall lie in Knox County, Tennessee.
25. In compliance with Tennessee state law, bids must be accompanied by a certification attesting that, to the best of the bidder's knowledge, the bidder does not engage in investment activities in Iran. The Iran Divestment Act of 2014 Certification of Non-inclusion form may be found in this solicitation

document.

26. By acceptance and delivery of the Purchase Order resulting from the award of this Invitation to Bid, the Vendor agrees to the following:

Contractor shall defend, indemnify and hold harmless the City, its officers, employees and agents from any and all liabilities which may accrue against the City, its officers, employees and agents or any third party for any and all lawsuits, claims, demands, losses or damages alleged to have arisen from an act or omission of Contractor in performance of this Agreement or from Contractor's failure to perform this Agreement using ordinary care and skill, except where such injury, damage, or loss was caused by the sole negligence of the City, its agents or employees.

Contractor shall save, indemnify and hold the City harmless from the cost of the defense of any claim, demand, suit or cause of action made or brought against the City alleging liability referenced above, including, but not limited to, costs, fees, attorney fees, and other expenses of any kind whatsoever arising in connection with the defense of the City; and Contractor shall assume and take over the defense of the City in any such claim, demand, suit, or cause of action upon written notice and demand for same by the City. Contractor will have the right to defend the City with counsel of its choice that is satisfactory to the City, and the City will provide reasonable cooperation in the defense as Contractor may request. Contractor will not consent to the entry of any judgment or enter into any settlement with respect to an indemnified claim without the prior written consent of the City, such consent not to be unreasonably withheld or delayed. The City shall have the right to participate in the defense against the indemnified claims with counsel of its choice at its own expense.

Contractor shall save, indemnify and hold City harmless and pay judgments that shall be rendered in any such actions, suits, claims or demands against City alleging liability referenced above.

The indemnification and hold harmless provisions of this Agreement shall survive termination of the Agreement.

CITY OF KNOXVILLE

BID FORM

TO: Purchasing Agent
City of Knoxville
Suite 667-674
City/County Building
400 Main Street
Knoxville, TN 37902

Having carefully examined the specifications for the "Traffic Signal Housings" to open on November 7, 2017 at 11:00 a.m. and the other Contract Documents and addenda, we hereby propose to furnish the products as specified:

Total (includes delivery): \$ _____/ea_

GUARANTEE of delivery no later than _____ days after receiving purchase order.
(Bidder must initial) _____

Firm Name: _____

Official Address: _____

(By)

(Name Typed)

(Title)

Date _____

Terms _____

Email address _____

Telephone _____

NON-COLLUSION AFFIDAVIT OF PRIME BIDDER

State of _____

County of _____

_____, being first duly sworn, deposes and says that:

- (1) He is owner, partner, officer, representative, or agent of _____, the Bidder that has submitted the attached Bid;
- (2) He is fully informed respecting the preparation and contents of the attached Bid and of all pertinent circumstances respecting such Bid;
- (3) Such Bid is genuine and is not a collusive or sham Bid;
- (4) Neither the said Bid nor any of its officers, partners, owners, agents, representatives, employees, or parties in interest, including this affiant, has in any way colluded, conspired, connived or agreed, directly or indirectly, with any other Bidder, firm or person to submit a collusive or sham Bid in connection with the Contract for which the attached Bid has been submitted or to refrain from proposing in connection with such Contract, or has in any manner, directly or indirectly, sought by agreement or collusion or communication or conference with any other Bidder, firm, or person to fix the price or prices in the attached Bid or of any other Bidder, firm, or person to fix any overhead, profit, or cost element of the bid price or the bid price of any other Bidder, or to secure through any collusion, conspiracy, connivance or unlawful agreement any advantage against the City of Knoxville or any person interested in the proposed Contract; and
- (5) The price or prices quoted in that attached Bid are fair and proper and are not tainted by any collusion, conspiracy, connivance or unlawful agreement on the part of the Bidder or any of its agents, representatives, owners, employees, or parties in interest, including this affidavit.

Signed: _____

Title: _____

Subscribed and sworn to before me this ____ day of _____, 2 ____.

My commission expires: _____

IRAN DIVESTMENT ACT
Certification of Noninclusion

NOTICE: Pursuant to the Iran Divestment Act, Tenn. Code Ann. § 12-12-106 requires the State of Tennessee Chief Procurement Officer to publish, using creditable information freely available to the public, a list of persons it determines engage in investment activities in Iran, as described in § 12-12-105. Inclusion on this list makes a person ineligible to contract with the state of Tennessee; if a person ceases its engagement in investment activities in Iran, it may be removed from the list. The State of Tennessee currently uses the State of South Carolina's list, available here:

[https://www.tn.gov/assets/entities/generalservices/cpo/attachments/List_of_persons_pursuant_to Tenn. Code Ann. 12-12-106, Iran Divestment Act-July.pdf](https://www.tn.gov/assets/entities/generalservices/cpo/attachments/List_of_persons_pursuant_to_Tenn._Code_Ann._12-12-106,_Iran_Divestment_Act-July.pdf)

By submission of this bid, each bidder and each person signing on behalf of any bidder certifies, and in the case of a joint bid each party thereto certifies as to its own organization, under penalty of perjury, that to the best of its knowledge and belief that each bidder is not on the list created pursuant to T.C.A. § 12-12-106.

Vendor Name (Printed)	Address
By (Authorized Signature)	Date Executed
Printed Name and Title of Person Signing	

NOTARY PUBLIC:

Subscribed and sworn to before me this _____ day of _____, 2_____.

My commission expires: _____

DIVERSITY BUSINESS ENTERPRISE (DBE) PROGRAM

The City of Knoxville strongly encourages prime contractors to employ diverse businesses in the fulfillment of contracts/projects for the City of Knoxville.

The City of Knoxville's Fiscal Year 2017 goal is to conduct 3.33% of its business with minority-owned businesses, 9.21% of its business with women-owned businesses, and 45.5% with small businesses.

While the City cannot engage (pursuant to state law), in preferential bidding practices, the city does **strongly encourage** prime contractors to seek out and hire diverse businesses in order to help the city meet its goals as stated above. As such, the City encourages prime contractors to seek out and consider competitive sub-bids and quotations from diverse businesses.

For DBE tracking purposes, the City requests that prime contractors who are bidding, proposing, or submitting statements of qualifications record whether or not they plan to employ DBE's as sub-contractors or consultants. With that in mind, please fill out, sign and submit (with your bid/proposal) the following sub-contractor/consultant statement.

Subcontractor/Consultant Statement
(TO BE SUBMITTED IN THE BID/PROPOSAL ENVELOPE)

We _____ do certify that on the _____
(Bidder/Proposer Company Name)

_____ (Project Name)
(\$ _____)
(Amount of Bid)

Please select one:

Option A: Intent to subcontract using Diverse Businesses

A Diversity business will be employed as subcontractor(s), vendor(s), supplier(s), or professional service(s). The estimated **dollar value** of the amount that we plan to pay is:

\$ _____
Estimated Amount of Subcontracted Service

Diversity Business Enterprise Utilization			
Description of Work/Project	Amount	Diverse Classification (MOB, WOB, SB, SDOV)	Name of Diverse Business

Option B: Intent to perform work “without” using Diverse Businesses

We hereby certify that it is our intent to perform 100 % of the work required for the contract, work will be completed without subcontracting, or we plan to subcontract with non-Diverse companies.

DATE: _____ COMPANY NAME: _____

SUBMITTED BY: _____ TITLE: _____
(Authorized Representative)

ADDRESS: _____

CITY/STATE/ZIP CODE: _____

TELEPHONE NO: _____

CITY OF KNOXVILLE DIVERSITY BUSINESS DEFINITIONS

Diversity Business Enterprise (DBE's) are minority-owned (MOB), women-owned (WOB), service-disabled veteran-owned (SDVO), and small businesses (SB), who are impeded from normal entry into the economic mainstream because of past practices of discrimination based on race or ethnic background. These persons must own at least 51% of the entity and operate or control the business on a daily basis.

Minority: A person who is a citizen or lawful admitted permanent resident of the United States and who is a member of one (1) of the following groups:

- a. African American, persons having origins in any of the Black racial groups of Africa;
- b. Hispanic American, persons of Mexican, Puerto Rican, Cuban, Central or South American or other Spanish culture or origin, regardless of race;
- c. Native American, persons who have origin in any of the original peoples of North America ;
- d. Asian American, person having origins in any of the original peoples of the Far East, Southeast Asia, the Indian subcontinent, or the Pacific Islands.

Minority-owned business (MOB) is a continuing, independent, for profit business that performs a commercially useful function, and is at least fifty-one percent (51%) owned and controlled by one (1) or more minority individuals.

Woman-owned business (WOB) is a continuing, independent, for profit business that performs a commercially useful function, and is at least fifty-one percent (51%) owned and controlled by one (1) or more women.

Service Disabled Veteran-owned business (SDOV) is a continuing, independent, for profit business that performs a commercially useful function, owned by any person who served honorably on active duty in the armed forces of the United States with at least a twenty percent (20%) disability that is service connected. Meaning such disability was incurred or aggravated in the line of duty in the active military, naval or air service, and is at least fifty-one percent (51%) owned and controlled by one (1) or more service disabled veteran.

Small Business (SB) is a continuing, independent, for profit business which performs a commercially useful function and has total gross receipts of not more than ten million dollars (\$10,000,000) average over a three-year period or employs no more than ninety-nine (99) persons on a full-time basis.

Front

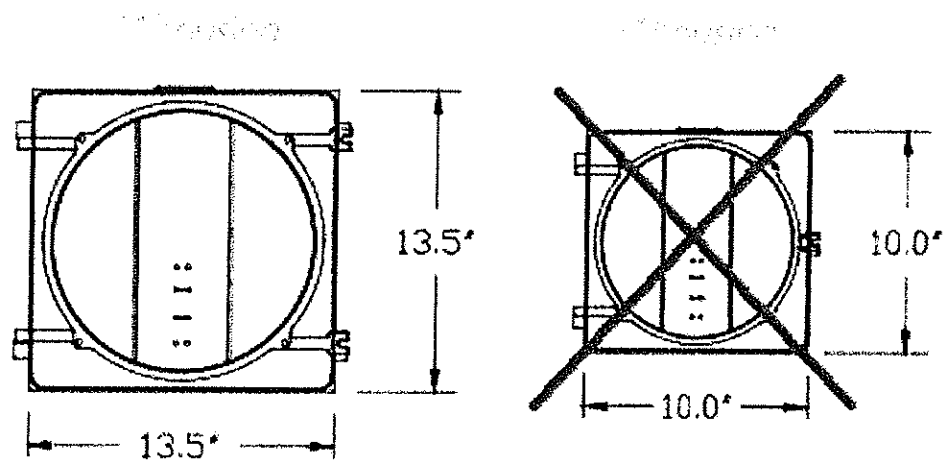

Top

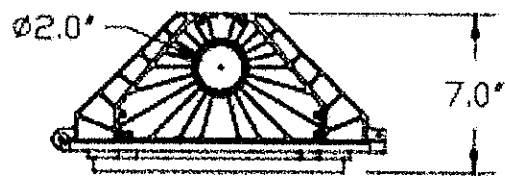

Side

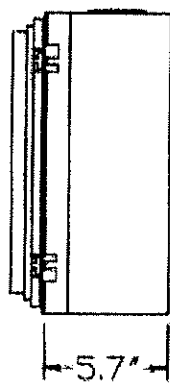

3-Section

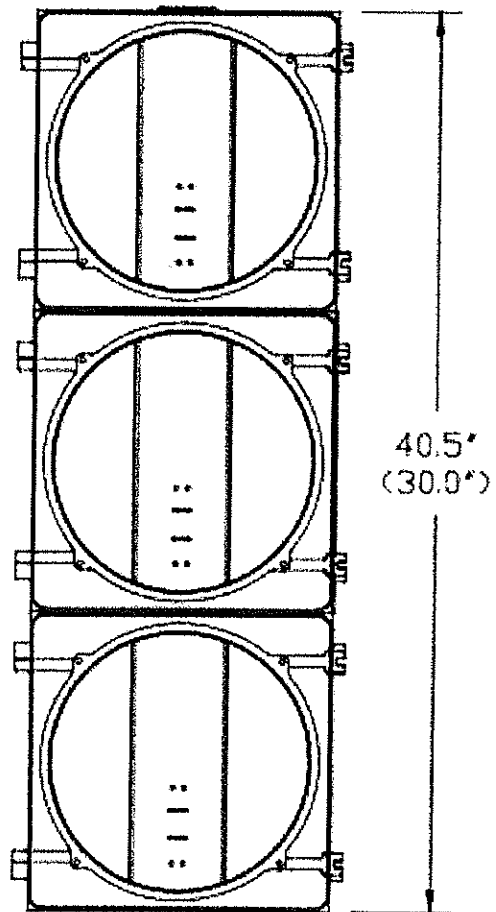

Item Requisition for Fixed Price Agreement

Type of Bid: Fixed Price Agreement

Term of Purchase Order: 1 year, renewable annually for two additional terms.

Item Description: 3-Section Signal Housings consisting of; One (1) 12" Aluminum top traffic signal housing with 5 position terminal block w/ neutral, two (2) lower 12" poly signal housings. Gloss Black in color. Please see drawing with dimensions.

Funding Source: Traffic Maintenance Fund

Minimum Annual Order for Bidding Purposes: 250

Vendor to provide Delivery schedule Based on Quantity.

No guarantee of Purchase

Quantity Price Breaks for additional purchases

	Bid Price	Delivery Schedule
Quantity 1-10 Each		
Quantity 11-50 Each		
Quantity 51-100 Each		
Quantity 101 +		

See Specifications