



CITY OF HAVELOCK

Post Office Box 368
Havelock, NC 28532

INVITATION TO BID

Pursuant to North Carolina General Statutes §143-129 the City of Havelock invites formal bids on the following:

Bids must be submitted in accordance with the attached specifications and must include an itemized schedule of quantity, unit price and total. Bids must be sealed and clearly marked on the outside of the envelope:

***“City of Havelock,
2022 Paving Maintenance Bid”***

Address Bids to: **Lee Tillman, Director of Finance**
 City of Havelock
 P.O. Box 368
 1 Governmental Ave.
 Havelock, NC 28532
 Email: Bids@havelocknc.us (formal bids cannot be emailed)

Bids will be accepted until **1:00 p.m. (EST) on Friday, October 28, 2022** at which time they will be reviewed in the office of the City Finance Director.

Bids on contracts for construction or repair work in the formal bidding range must be accompanied by a bid bond or deposit in the amount of not less than 5 percent of the bid. Bid bonds shall be enclosed in a separate envelope and attached to the outside of the sealed bid package. This security is held by the City of Havelock to guarantee that the successful bidder will execute the contract and provide performance and payment bonds if required. If a bidder backs out of his or her bid or refuses to enter into a contract, the City of Havelock may retain the bid deposit or seek payment under the bid bond. Bids will be considered incomplete if not accompanied by a bid bond or deposit. The bids are good for 75 days after opening. The winning bidder will be issued a Notice To Proceed (NTP) along with a Purchase Order. The performance period is 90 calendar days from the NTP.

Bidders are cautioned not to submit bids until the proposed requirements and specifications have been carefully examined. It will be considered that bidders will have satisfied themselves as to the accuracy of the specifications. No proposal will be considered unless prices are submitted for all items requested in any section. The City reserves the right to change the amount of quantities.

All bids submitted should be to the desired specifications. Any exceptions to the specifications will be evaluated based on the best interest of the City. Any deviation from specifications indicated herein must be clearly pointed out; otherwise, it will be considered that items offered are in strict compliance with these specifications, and bidder will be held responsible therefore. Deviations shall be explained in detail. The bidder shall not construe this paragraph as inviting deviation or implying that any deviation will be acceptable.

The names of certain brands or makes denote quality standard in the article desired, but do not restrict bidders to the specific brand, make or manufacturer named. They are meant to convey to prospective bidders the general style, type, character and quality of the article desired.

The successful bidder on all construction contracts will be required to conduct the operation in accordance with all Federal, State, and Municipal health and safety rules, regulations and laws applicable to the operation. The successful bidder may be asked to provide the City with a copy of the company's safety plan prior to commencing work. For all projects over \$30,000, a general contractor's license must be furnished to the City if applicable.

Certificate to Transact Business in North Carolina: As a condition of contract award, each out-of-State Vendor that is a corporation, limited-liability company or limited-liability partnership shall have received, and shall maintain throughout the term of The Contract, a Certificate of Authority to Transact Business in North Carolina from the North Carolina Secretary of State, as required by North Carolina law. A contract requiring only an isolated transaction completed within a period of six months, and not in the course of a number of repeated transactions of like nature, shall not be considered as transacting business in North Carolina and shall not require a Certificate of Authority to Transact Business.

The City will not sell bid packages. Plans, specifications, and addenda may be viewed and obtained online at www.havelocknc.us. Click on: "Bid on a Contract"; "Current Bids". The Bidder's List is maintained by Vendor Registry. Registration for the Bidder's List is made online at www.havelocknc.us. Click on: "Bid on a Contract"; "Vendor login/Registration".

N.C.G.S. (North Carolina General Statutes), specifically §160A-20.1(b), prohibit the City from entering into contracts with contractors and subcontractors who have not complied with the requirement of Article 2 or Chapter 64. The Contractor shall submit the E-Verify Affidavit, located in the Bid Proposal section, with their bid. Bids that do not include this Affidavit will be considered non-responsive.

N.C.G.S 147-86.42-84 requires that contractors with a North Carolina Local Government must not utilize any subcontractor found on the State Treasurer's Iran Divestment list or Companies Boycotting Israel list. The referenced lists can be found on the State Treasurer's website at the address www.nctreasurers.com and will be updated every 180 days.

The City of Havelock reserves the right to reject any or all proposals and to purchase items from the state contract in the efforts to award the contract to the bidder it deems to be for the best interest of the City.

MODIFICATION AND WITHDRAWAL OF BIDS. Bids may be modified or withdrawn by an appropriate document duly executed (in the manner that a Bid must be executed) and delivered to the place where Bids are to be submitted at any time prior to the opening of Bids. A request to withdraw a bid may be made to the Owner within 72 hours after Bids are opened in accordance with NCGS § 143-129.1 Requests to withdraw a Bid will be subject to the requirements of NCGS §143-129.1 and in the sole discretion of the City of Havelock Finance Officer.

This institution is an equal opportunity provider, and employer.

Contact person(s) for information on this bid:

For questions in regards to the bid specifications, the City requires and only responds to questions submitted in writing and sent via email to: Bids@havelocknc.us. Questions must be received by **12:00**

PM (EST) on Friday, October 21, 2022 and will be answered by 2:00 PM (EST) on Friday, October 28, 2022.

Today is the 27th day of September 2022

Published: Vendor Registry September 27, 2022

CITY OF HAVELOCK

Lee W. Tillman
Director of Finance



**STATE OF NORTH CAROLINA
AFFIDAVIT
CITY OF HAVELOCK**

I, _____ (the individual attesting below), being duly authorized by and on behalf of _____ (the entity hereinafter "Employer") after first being duly sworn hereby swears or affirms as follows:

1. Employer understands that E-Verify is the federal E-Verify program operated by the United States Department of Homeland Security and other federal agencies, or any successor or equivalent program used to verify the work authorization of newly hired employees pursuant to federal law in accordance with NCGS §64-25(5).
2. Employer understands that Employers Must Use E-Verify. Each employer, after hiring an employee to work in the United States, shall verify the work authorization of employee through E-Verify in accordance with NCGS §64-26(a).
3. Employer is a person, business entity, or other organization that transacts business in the State and that employs 25 or more employees in this State. (mark Yes or No)
 - a. YES _____
 - b. NO _____
4. Employer's subcontractors comply with E-Verify, and if Employer is the winning bidder on this project, Employer will ensure compliance with E-Verify by any subcontractors subsequently hired by Employer.

This _____ day of _____, 20_____.

Signature of Affiant: _____

Print or Type Name: _____

State of North Carolina County of _____

Signed and sworn to (or affirmed) before me, this the _____ day of _____, 20_____.

Signature of Notary Printed Name of Notary

My Commission Expires: _____

Bid Sheet

Base Bid: _____

NC Sales Tax: _____

Delivery Cost (if applicable): _____

Total Cost to City: _____

Bids must include an itemized schedule by quantity, unit price and total for each work element.

Company Name: _____

Company Address: _____

Contact Person: _____

Telephone Number: _____

Email Address: _____

NC Contractor's License Type and Number: _____

Number of Addendums Acknowledged (circle one): N/A 1 2 3 4

As of the date listed below, the vendor or bidder listed above is compliant with N.C.G.S. 147-86.42-84, the Iran Divestment Act and the Companies Boycotting Israel Act.

Authorized Signature: _____

Print Name of Authorized Signature: _____

Title: _____

Address Bid to: Lee Tillman, Director of Finance
City of Havelock
P.O. Drawer 368
1 Governmental Avenue
Havelock, NC 28532
Bids@Havelocknc.us (formal bids cannot be emailed)

Please indicate the Bid name on the outside of the envelope.

HAVELOCK 2022 PAVING MAINTENANCE BID

September 27, 2022



CITY OF HAVELOCK
NORTH CAROLINA

TABLE OF CONTENTS

INVITATION TO BID.....	1
STANDARD SPECIAL PROVISIONS.....	5
ADDENDA.....	5
ADDITIONAL WORK (NCDOT SECTION 101-3, DEFINITIONS)	5
AWARDING OF CONTRACT.....	5
CARE OF WORK.....	5
CITY OF HAVELOCK DRUG-FREE WORKPLACE POLICY.....	5
CLEANING UP	6
CLEARING AND GRUBBING	6
CONSTRUCTION STAKES, LINES AND GRADES.....	6
CONTRACT BONDS (NCDOT SECTION 103-7 AND 103-9)	6
CONTRACT TIME EXTENSIONS (NCDOT SECTION 108-10, CONTRACT TIME: INTERMEDIATE CONTRACT TIME)	6
DEFINITION OF TERMS.....	6
EROSION AND SEDIMENTATION CONTROL MEASURES.....	7
EXECUTION OF CONTRACT	7
EXTRA WORK (NCDOT SECTION 101-3, DEFINITIONS)	7
GUARANTEE	8
HAZARDOUS MATERIALS	8
INDEMNIFICATION.....	8
INSURANCE REQUIREMENTS	8
MATERIALS AND EQUIPMENT STORAGE	9
NOTICE TO PROCEED / NOTICE OF AWARD	9
OSHA REQUIREMENTS.....	9
PERIODIC PAYMENTS.....	9
PRE-CONSTRUCTION CONFERENCE.....	10
PROJECT CLOSEOUT DOCUMENTS.....	10
QUANTITY TICKETS	10
REFERENCES	11
SAWING EXISTING PAVEMENT	11
SEEDING AND MULCHING.....	11
STANDARD SPECIFICATIONS	11
SUBLETTING.....	11
SUBSURFACE INVESTIGATION	11
TAX STATEMENT SUBMITTAL	11
TAXES AND LICENSES	12
TERMINATION BY THE CITY FOR CAUSE	12
TERMINATION BY THE CITY FOR CONVENIENCE	13
TREE PROTECTION.....	13
UNDERCUT EXCAVATION	13
PROJECT SPECIAL PROVISIONS.....	14
ADJUSTMENT OF VALVE BOXES AND MANHOLES.....	14
ANTICIPATED WORK SCHEDULE.....	14
ASPHALT CEMENT FOR PLANT MIX	14
ASPHALT SURFACE TREATMENT, MAT COAT, NO. 6 STONE	14
ASPHALT TESTING	14
CONTRACT ADDITIONS.....	15
CONTRACT PERIOD	15
LIQUIDATED DAMAGES.....	15

LOCATION OF THE PROJECT	15
MILLING ASPHALT PAVEMENT	15
PAVEMENT RESURFACING	15
PORTABLE CONSTRUCTION ZONE TRAFFIC CONTROL DEVICES	15
TRAFFIC CONTROL.....	16
<i>(PAGE INTENTIONALLY LEFT BLANK)</i> SPECIAL PROVISION PAY ITEMS.....	18
SP-1, GRADING.....	19
SP-5, ASPHALT COURSE.....	20
SP-6, SHOULDER REPAIR	20
ITEMIZED PROPOSAL SECTION.....	21
ACKNOWLEDGMENT OF ADDENDA	22
ITEMIZED PROPOSAL	23
EXECUTION OF BID	24
BONDS AND CERTIFIED POWER OF ATTORNEY	25
FORMS	26
CONTRACTOR'S AFFIDAVIT RELEASE AND WAIVER OF CLAIM	27
CONTRACTOR'S AFFIDAVIT OF PAYMENT OF DEBTS AND CLAIMS	28
STATE/COUNTY SALES/USE TAX STATEMENT	29
AGREEMENT	31

APPENDIX A

- **HAVELOCK 2022 PAVING MAINTENANCE STREET LIST**
- **HAVELOCK 2022 PAVING MAINTENANCE MAP**
- **DETAIL DRAWINGS**
 - **UTILITY ADJUSTMENTS FOR RESURFACING**
 - **RESURFACING AND MILLING TYPICAL SECTIONS**
 - **SHOULDER TYPICAL SECTION**
- **QUALITY MANAGEMENT SYSTEM (QMS) FORMS**
 - **DAILY PAVING OPERATION EVALUATION FORM**
 - **QA/QC-8 Daily Paving Operation Evaluation Form**

INVITATION TO BID

The City of Havelock (hereinafter the "City") will receive sealed bids for the following Project:

PROJECT NAME: Havelock 2022 Paving Maintenance

BID DATE AND TIME: October 28, 2022 1:00 p.m.

BID OPENING LOCATION: Havelock City Hall
Finance Office
1 Governmental Avenue
Havelock, NC 28532

SCOPE OF WORK: This project includes: grading, asphalt milling, asphalt overlay, adjustment of water valves and manholes, and shoulder repair.

This is a Formal Bid. Proposals will be opened and read on the bid date at the Havelock City Hall. Bidders are invited to be present. No emailed bids will be accepted.

Bid Documents The City will not sell bid packages. Plans, specifications, and addenda may be viewed and obtained online at www.havelocknc.us. Click on: "Bid on a Contract"; "Current Bids". The Bidder's List is maintained by Vendor Registry. Registration for the Bidder's List is made online at www.havelocknc.us. Click on: "Bid on a Contract"; "Vendor login/Registration".

Bid Bond or Bid Deposit: Each bid that equals or exceeds \$100,000 shall be accompanied by a corporate bid bond or a bid deposit of a certified or cashier's check in the amount of at least 5% of the total amount bid for the contract. When a bid is secured by a bid deposit (certified check or cashier's check), the execution of a bid bond will not be required.

When the bid security is in the form of a bid bond, that bid bond shall be executed by a corporate surety licensed in North Carolina to execute such bonds.

When the bid security is in the form of a cashier's check, or a certified check, that check shall be written on a bank or trust company insured by the Federal Deposit Insurance Corporation, made payable to the order of the City of Havelock.

A Performance Bond and Payment Bond, each in the amount of one hundred (100) percent of the Contract Price, with a corporate surety approved by the City, will be required from the successful bidder as security for the faithful performance and the payment of all bids and obligations arising from the performance of the contract.

Contractor's License for Construction Contracts: Bidders shall comply with all applicable laws regulating the practice of General Contracting as required by the General Statutes of North Carolina that require the Bidder to be licensed by the North Carolina Licensing Board for General Contractors when bidding on any project where the bid is \$30,000 or more.

The Bidder will provide his North Carolina General Contractor's License Number, Classification(s), and Limits in the space provided on the signature page of the bid.

Delay in Award: Bids may be held by the City for a period not to exceed ninety (90) days from the date of the bid opening for the purpose of reviewing bids and investigating qualifications of Bidders.

Equal Employment Opportunity: Bidders will ensure that employees and applicants for employment are not discriminated against because of their race, color, religion, sex, national origin, disability, or veteran's status.

Itemized Proposal Form: The itemized proposal form provided by the City shall be used and the Project Manual in its entirety (the Project Manual shall not be altered) shall be submitted for bid consideration. All entries including signatures shall be written in ink.

Delivery of Bids: Bids shall be hand delivered or mailed to the Office of the Finance Director prior to the bid opening. All bids shall be placed in a sealed envelope with the following information printed on the outside of the envelope:

<p>BID FOR: _____ (Enter the project name as shown on the Bid Documents) <i>Project Name</i></p> <p>BIDDER'S NAME: _____ (Full name of Contractor submitting the bid) <i>Contractor's Name</i></p> <p>DO NOT OPEN UNTIL: _____ (Enter the date & time as shown on the Bid Documents) <i>Bid Opening Date & Time</i></p>
--

If mailed, the envelope shall be placed inside another envelope addressed to Lee W. Tillman, Finance Director, City of Havelock, 1 Governmental Avenue, Havelock, NC 28532.

Bid Phase Contact: For questions in regards to the bid specifications, the City requires and only responds to questions submitted in writing and sent via email to:

Contact Person: Lee Tillman

E-Mail Address: bids@havelocknc.us

Questions must be received by **2:00 PM (EST) on Friday, October 14, 2022**. If questions are received, the City will respond no later than **12:00 PM (EST) on Thursday, October 20, 2022**.

The City of Havelock reserves the right to reject any or all proposals, waive irregularities and/or informalities in any proposal and make an award in any manner consistent with the law deemed in the best interest of the City.

Lee W. Tillman
Finance Director



CITY OF HAVELOCK

Post Office Box 368
Havelock, NC 28532

N.C.G.S. (North Carolina General Statutes), specifically §160A-20.1(b), prohibit the City from entering into contracts with contractors and subcontractors who have not complied with the requirement of Article 2 of Chapter 64. The Contractor shall submit the E-Verify Affidavit, located in the Bid Proposal section, with their bid. Bids that do not include this Affidavit will be considered non-responsive.

N.C.G.S 147-86.55-69 requires certification for bids with a North Carolina Local Government. The certification is required at the time when a bid is submitted. N.C.G.S 147-86.55-69 requires that contractors with a North Carolina Local Government must not utilize any subcontractor found on the State Treasurer’s Final Divestment List. The State Treasurer’s Final Divestment List can be found on the State Treasurer’s website at the address www.nctreasurers.com/Iran and will be updated every 180 days.

The City of Havelock reserves the right to reject any or all proposals and to purchase items from the state contract in the efforts to award the contract to the bidder it deems to be for the best interest of the City.

This institution is an equal opportunity provider, and employer.

**IRAN DIVESTMENT ACT CERTIFICATION
REQUIRED BY N.C.G.S 147-86.55-69**

As of the date listed below, the vendor or bidder listed above is not listed on the Final Divestment List created by the State Treasurer pursuant to N.C.G.S. 147-86.55-69.

The undersigned hereby certifies that he or she is authorized by the vendor or bidder listed above to make the forgoing statement.

Authorized Signature: _____

Print Name of Authorized Signature: _____

Title: _____



STATE OF NORTH CAROLINA
AFFIDAVIT
CITY OF HAVELOCK

I, _____ (the individual attesting below), being duly authorized by and on behalf of _____ (the entity hereinafter "Employer") after first being duly sworn hereby swears or affirms as follows:

- 5. Employer understands that E-Verify is the federal E-Verify program operated by the United States Department of Homeland Security and other federal agencies, or any successor or equivalent program used to verify the work authorization of newly hired employees pursuant to federal law in accordance with NCGS §64-25(5).
- 6. Employer understands that Employers Must Use E-Verify. Each employer, after hiring an employee to work in the United States, shall verify the work authorization of employee through E-Verify in accordance with NCGS §64-26(a).
- 7. Employer is a person, business entity, or other organization that transacts business in the State and that employs 25 or more employees in this State. (mark Yes or No)
 - b. YES _____, or
 - c. NO _____
- 8. Employer's subcontractors comply with E-Verify, and if Employer is the winning bidder on this project Employer will ensure compliance with E-Verify by any subcontractors subsequently hired by Employer.

This ____ day of _____, 20__.

Signature of Affiant
Print or Type Name: _____

State of North Carolina County of _____

Signed and sworn to (or affirmed) before me, this the ____ day of _____, 20__.

Signature of Notary Printed Name of Notary

(Affix Official/Notarial Seal)

STANDARD SPECIAL PROVISIONS

ADDENDA

Addenda will be posted on the City's website. Vendors should register on the City's website to receive updates by email. The Bidder shall be responsible for reviewing the City of Havelock website or inquiring if Addenda have been issued. All such Addenda shall become part of the contract and all Bidders shall be bound by such Addenda whether or not received or acknowledged by the Bidder.

ADDITIONAL WORK (NCDOT Section 101-3, Definitions)

Additional work is that which results from a change or alteration in the contract and for which there are existing contract unit prices.

AWARDING OF CONTRACT

The City will award the contract or contracts conditioned upon funds being available for construction and other governmental approvals as may be required. The contract will be awarded to the lowest responsive and responsible Bidder or Bidders, as required by North Carolina General Statutes. The City intends to award the full contract but reserves the right to negotiate select areas dependent upon funding. Consideration will be given only to proposals from Contractors who are properly licensed, bonded, experienced in the class of work proposed and who can refer to projects of similar magnitude and character that have been completed by them. The City also reserves the right to reject any and all proposals and to waive informalities and technicalities as it may deem to be in its best interest.

CARE OF WORK

The Contractor shall furnish and erect, at no additional cost to the City, whatever sidewalks, bridges, culverts, or other works as may be necessary for the protection of the public, including, but not limited to, barricades, fences, etc. and for the safe and proper execution of other public utility lines so as not to interfere therewith or damage or cause damage thereto. The Contractor shall be responsible for all damages to persons or property that occur as a result of his fault, omission, or negligence in connection with the prosecution of the work and shall be responsible for the proper care and protection of all work performed hereunder until completion and final acceptance, whether or not the same has been covered in whole or in part by payments made by the City.

CITY OF HAVELOCK DRUG-FREE WORKPLACE POLICY

The City is a drug-free workplace employer.

In order to be eligible to submit a bid or proposal for a City construction or service contract, a prospective contractor must certify that it will, if awarded the contract, provide a drug-free workplace during the performance of the contract. This requirement is met by:

- (1) Notifying employees that the unlawful manufacture, distribution, dispensation, possession, or use of a controlled substance is prohibited in the workplace and specifying the actions that will be taken for violations of such prohibition;
- (2) Establishing a drug-free awareness program to inform employees about (1) the dangers of drug abuse in the workplace, (2) the Contractor's policy of maintaining a drug-free workplace, (3) any available drug counseling, rehabilitation, and employee assistance program, and (4) the penalties that may be imposed upon employees for drug abuse violations;
- (3) Notifying each employee that as a condition of employment, the employee will (1) abide by the terms of the prohibition outlined in (1) above and (2) notify the Contractor of any criminal drug statute conviction for a violation occurring in the workplace no later than five days after such conviction;

- (4) Notifying the City within ten days after receiving from an employee a notice of a criminal drug statute conviction or otherwise receiving actual notice of such conviction;
- (5) Imposing a sanction on, or requiring the satisfactory participation in a drug counseling, rehabilitation or abuse program by an employee convicted of drug crime;
- (6) Making a good faith effort to continue to maintain a drug-free workplace for employees; and
- (7) Requiring any party to which it subcontracts any portion of the work under the contract to comply with the provisions of (1) through (6).

If the prospective contractor is an individual, the drug-free workplace requirement is met by not engaging in the unlawful manufacture, distribution, dispensation, possession, or use of a controlled substance in the performance of the contract.

By submitting a bid or proposal, a prospective contractor certifies that it will comply with the City's drug-free workplace requirement. A false certification or the failure to comply with the above drug-free workplace requirements during the performance of a contract shall be grounds for suspension, termination or debarment.

CLEANING UP

Before acceptance of the Project, or as directed by the Public Works Director; waste areas, and all ground occupied by the Contractor within the Project limits in connection with the work shall be cleaned of all rubbish, excess materials, temporary structures, and equipment.

CLEARING AND GRUBBING

Clearing on this Project shall be performed to the slope stake line or the right-of-way line unless directed otherwise. The Contractor shall obtain permission from the Public Works Director prior to removing any trees in the right-of-way areas.

CONSTRUCTION STAKES, LINES AND GRADES

Construction stakes, lines and grades will be provided by the Contractor at his own expense. Costs for surveys and establishing grades shall be included with the various bid items.

CONTRACT BONDS (NCDOT Section 103-7 and 103-9)

The successful bidder, within 14 calendar days after the notice of award is received by him, shall provide the City with a contract payment bond and a contract performance bond each in an amount equal to 100 percent of the amount of the contract. All bonds shall be in conformance with G.S. 44A-33. The corporate surety furnishing the bonds shall be authorized to do business in the State.

The successful bidder's failure to file acceptable bonds within 14 calendar days after the notice of award is received by him shall be just cause for the forfeiture of the bid bond or bid deposit and rescinding the award of the contract. Award may then be made to the next lowest responsible bidder or the work may be readvertised and constructed under contract or otherwise, as the City may decide.

CONTRACT TIME EXTENSIONS (NCDOT Section 108-10, Contract time: Intermediate Contract Time)

The Contractor's attention is directed to Article 108-10 in the Standard Specifications. Item number (5) of sub-article 108-10 (b) shall be deleted in its entirety.

DEFINITION OF TERMS

Whenever the following terms are used in the Standard Specifications, or in any of the Contract Documents, the intended meaning of such terms shall be as follows:

1. "State" or "Department" shall be replaced by the words "City of Havelock"

2. "Engineer" or "Resident Engineer" shall be replaced by the words "Public Works Director or his duly authorized representative"
3. "Public Works Director" shall include to mean "or his duly authorized representative"
4. "Sampling and Testing by Department" shall be replaced by the words "Sampling and Testing by City or its approved testing agency"
5. "Inspection by Department" shall be replaced by the words "Inspection by the City or its duly authorized representative"
6. "City Standard" shall be verified in discussions with the Public Works Director
7. "City Water Main Standard" and "City Sanitary Sewer Standard" shall be verified in discussions with the Public Works Director
8. Standard Specifications are defined by Standard Specifications for Roads and Structures, North Carolina Department of Transportation.

EROSION AND SEDIMENTATION CONTROL MEASURES

The Contractor shall install and maintain all erosion and sedimentation control measures and devices necessary to comply with all applicable local and state ordinances and laws. All erosion and sedimentation control measures and devices shall be installed prior to beginning clearing or grading operations. Such devices shall be maintained in proper working condition from installation throughout the duration of the Project.

The Contractor shall indemnify and hold harmless the City for any penalties imposed against the City by any local or state agency for the Contractor's failure to install and properly maintain erosion and sedimentation control devices. The Contractor shall immediately correct any deficiencies in erosion and sedimentation measures identified by the City or local or state agency. If the Contractor fails to correct the deficiencies within 24 hours after notification, the City will have such corrections performed and assess the cost of these corrections plus a 100% surcharge against the Contractor.

The Contractor shall include the cost of installing and maintaining erosion and sedimentation control devices in the price bid for Grading unless otherwise specified.

If any borrow or waste areas are to be utilized, it shall be the responsibility of the Contractor to notify the property owner that the property owner is responsible for any damage occurring from the site, either as part of the agreement with the Contractor, or on his own. All work, sediment control structures, and seeding will be at the cost of the property owner or Contractor.

The City will not participate in the cost of this work on the waste or borrow areas. Prior to final payment being made, the Contractor shall obtain a release from the property owner of the borrow or waste site utilized for the Project.

EXECUTION OF CONTRACT

As soon as possible following the bid-opening and receipt of the properly executed contract, the City will complete the execution of the contract, retain the original contract, and return three copies of the fully executed contract, including specifications, to the Contractor. Additional sets may be obtained at the cost of printing.

EXTRA WORK (NCDOT Section 101-3, Definitions)

Work found necessary or desirable to complete fully the work as contemplated in the contract for which payment is not provided for by the contract unit or lump sum prices in the original contract.

Extra work shall not be work which in the terms of the specifications and special provisions is incidental to work for which there is a contract price or work for which payment is included in some other contract unit or lump sum price.

Extra work shall be performed in accordance with the specifications and as directed by the Public Works Director. No extra work shall be commenced prior to specific authorization for the performance of such extra work being given by the Public Works Director.

Extra work which is specifically authorized by the Public Works Director will be paid for in accordance with sub-article 104-7, Extra Work, Sub-Article (A).

GUARANTEE

The Contractor shall guarantee all materials and workmanship for a period of one (1) year from the date of acceptance by the City and shall replace any portions that fail because of faulty materials or workmanship at no additional cost to the City. A six (6) month and eleven (11) month inspection will be held during the warranty period. The Contractor shall immediately repair all defective items upon notification. Items repaired under the provisions shall have an extended warranty period of twelve (12) months from the date of repair of the item.

HAZARDOUS MATERIALS

If the Contractor encounters any materials considered or suspected of being hazardous, he shall immediately secure the area and contact 911 for further instructions.

INDEMNIFICATION

To the fullest extent permitted by law, the Contractor shall indemnify and hold harmless the City and its agents and employees, from and against all claims, damages, losses and expenses, including attorneys' fees, arising out of or resulting from the performance of the work, provided that any such claim, damage, loss or expense (1) is attributable to bodily injury, sickness, disease or death, or to injury to or destruction of tangible property (other than the work itself) including the loss of use resulting there-from, and (2) is caused in whole or in part by any negligent act or omission of the Contractor, any Subcontractor, anyone directly or indirectly employed by any of them or anyone for whose acts any of them may be liable, regardless of whether or not it is caused in part by a party indemnified hereunder. Such obligation shall not be construed to negate, abridge, or otherwise reduce any other right or obligation of indemnity which would otherwise exist as to any party or person described in this paragraph.

In any and all claims against the City or any of its agents or employees by any employee of the Contractor, any Subcontractor, anyone directly or indirectly employed by any of them, or anyone for whose acts any of them may be liable, the indemnification obligation under this paragraph shall not be limited in any way by any limitation on the amount or type of damages, compensation or benefits payable by or for the Contractor or any Subcontractor under workers' or workmen's compensation acts, disability benefit acts, or other employee benefit acts.

INSURANCE REQUIREMENTS

Contractor's Liability and Other Insurance: The Contractor shall purchase and maintain with a company acceptable to the City and authorized to do business in the State of North Carolina, such insurance as will protect him from claims under workers' compensation laws, disability benefit laws or other similar employee benefit laws; from claims of damages because of bodily injury, occupational sickness or disease, or death of his employees; from claims for damages because of bodily injury and personal injury; and from claims for damage and destruction of tangible property, including loss of use resulting there-from – any or all of which may arise out of or result from the Contractor's operations under the Contract Documents, whether such operations be by himself or any subcontractor or anyone directly or indirectly employed by any of them or for whose acts any of them may be legally liable.

The insurance shall be written for not less than the limits of liability specified below.

Automobile: Bodily injury and property liability covering all owned, non-owned and hired automobiles for limits of not less than \$1,000,000 bodily injury each person, each accident and \$1,000,000 property damage, or \$1,000,000 combined single limit – bodily injury and property damage combined.

Commercial General Liability: Bodily injury and property damage liability as shall protect the Contractor and any subcontractor performing work under this Contract from claims of bodily injury or property damage which arise from operations of this Contracts, whether such operations are performed by the Contractor, any subcontractor, or anyone directly or indirectly employed by either. The amounts of such insurance

shall not be less than \$1,000,000 bodily injury each occurrence/aggregate and \$1,000,000 property damage each occurrence/aggregate or \$1,000,000 bodily injury and property damage combined single limits each occurrence/aggregate. This insurance shall include coverage for products/completed operations, personal injury liability and contractual liability assumed under the indemnity provision of this Contract and broad form property damage, explosion, collapse and underground property damage (XC&U). The coverage shall be on an occurrence basis.

Workers' Compensation and Employers' Liability: Shall meet the statutory requirement of the State of North Carolina, in an amount of \$100,000 each accident and disease – each employee and \$500,000 disease policy limit providing coverage for employees and owners.

The City shall be named as an additional insured under the commercial liability insurance for operations or services rendered under this Contract.

At the time of execution of the Contract, the Contractor shall provide the City with insurance certificates certifying that the foregoing insurance is in force; and such insurance certificates shall include provisions that the insurance shall not be cancelled, allowed to expire, or be materially changed without giving the City thirty (30) days advance written notice by registered mail.

The Contractor is advised that if any part of the work under this Contract is sublet, he shall require the subcontractor(s) to carry insurance as required above. However, this will in no way relieve the Contractor from providing full insurance coverage on all phases of the Project, including any that are sublet.

When certain work is performed inside rights-of-way owned by railroads, North Carolina Department of Transportation or other agencies, both the Contractor and any subcontractors may be required to furnish individual insurance certificates made in favor by the controlling agency, with limits established by that agency.

MATERIALS AND EQUIPMENT STORAGE

The Contractor shall be responsible for locating and providing storage areas for construction materials and equipment. The material and equipment storage shall comply with all local and state ordinances throughout the construction period. The Contractor shall restore the storage area to its original condition upon completion of the Project or upon such time as directed by the Public Works Director. Such restoration shall be at no additional cost to the City.

The Contractor shall be responsible for the safeguarding of materials and equipment against fire, theft and vandalism and shall not hold the City responsible in any way for the occurrences of same. The Contractor shall furnish and erect, at no additional cost, whatever works may be necessary for the protection of the public, including but not limited to barricades, fences, etc. Prior to final payment being made, the Contractor shall obtain a release from the property owner of the storage area utilized for the Project.

NOTICE TO PROCEED / NOTICE OF AWARD

A Notice to Proceed / Notice of Award will be issued to the Contractor upon receipt of a fully executed contract, bonds, insurance certificates, receipt of approval by other governmental agencies (if required) and any other documentation required by the City.

OSHA REQUIREMENTS

The Contractor shall comply with OSHA 29 CFR Part 1926, Subpart P – Excavations, 29 CFR Part 1910.146, Permit-required confined spaces and all other applicable regulations.

PERIODIC PAYMENTS

The City will make periodic payments based on the work progress estimates prepared by the Public Works Director and the payment request submitted by the Contractor on a monthly schedule established by the Public Works Director. Payment will be made within thirty (30) calendar days after receipt of a correct Payment Request.

Payment Requests must include:

- 1) List of Streets
- 2) Completed Repairs
- 3) Sales / Use Tax Paid Statement

For contracts less than \$50,000, partial payments may be made twice each month if, in the judgment of the City, the amount of work performed is sufficient to warrant such payment. No partial payment will be made when the total value of the work performed since the last partial payment, excluding mobilization, is less than \$1,000.00.

Payment requests and tax statements shall be submitted on the forms provided by the City (see Tax Statement Submittal section of this contract).

The Contractor shall have a copy of his current payment request on the job site and it may be viewed by subcontractors upon request.

An amount equal to five percent (5%) of the total amount due on payment requests will be deducted and retained until fifty percent (50%) of the work has been completed. At this time, the Public Works Director may reduce the amount of retainage if, in his opinion, work has been progressing satisfactorily. Any reduction of retainage below five percent (5%) will be strictly at the discretion of the Public Works Director, and will require consent of surety. The full contract retainage may be retained if the manner of completion of the work and its progress do not remain satisfactory to the Public Works Director, or for other good and sufficient reason.

Payment will be made on ninety percent (90%) of materials on hand stored on the Project site, or in a bonded warehouse. Requests for payment of materials on hand shall be accompanied by the original supplier's invoice and proof of insurance coverage of the storage facility.

PRE-CONSTRUCTION CONFERENCE

A pre-construction conference will be scheduled as soon as practical after the award of the Contract. The Contractor shall attend the conference along with the prospective job superintendent, any anticipated major subcontractors and major material suppliers. A proposed progress schedule in a form satisfactory to the Public Services Director and a statement of the anticipated monthly progress payments showing the percent of progress each month shall be submitted.

During the Pre-Construction Conference, the Contractor shall provide the City with documentation that the asphalt / bituminous concrete pavement to be provided for this project will be provided by a NCDOT Certified Plant.

The Contractor shall also provide at least two (2) local telephone numbers that may be used to contact the Contractor or his authorized representative in the event of an emergency after normal business hours. Upon receipt of the required documentation, a Notice to Proceed will be issued by the City.

PROJECT CLOSEOUT DOCUMENTS

The Contractor shall provide the following documents with the final pay request:

1. Contractor's Affidavit Release and Waiver of Claim
2. Contractor's Affidavit of Payment of Debts and Claims
3. State/County Sales/Use Tax Statement (Provided with each Payment Request)
4. Consent of Surety to Final Payment (contracts equal to or exceeding \$100,000) (AIA Document G707)

No final payment will be authorized until these documents have been properly completed and submitted by the Contractor.

QUANTITY TICKETS

All quantity tickets for items not measurable in place shall be submitted in duplicate to the Project Inspector within seventy-two (72) hours after receipt of the material on the job. Each ticket shall indicate the date,

contractor, job location and name, type of material, quantity of material, truck number and signature of the Contractor or his authorized representative.

No tickets will be accepted after seventy-two (72) hours have elapsed between the time of delivery and the submittal of tickets to the Project Inspector.

REFERENCES

All bidders must supply at least three references of previous similar projects completed.

SAWING EXISTING PAVEMENT

Where asphalt or concrete (curb, sidewalk, roadway, driveways, parking lots, etc.) is to be removed, the Contractor shall provide a neat edge along the pavement being retained by sawing the pavement a minimum of 2" deep and 1' wide before breaking and removing adjacent pavement.

When the Contractor proposes to saw pavement more than one foot from the proposed pavement (curb, sidewalk, structure, etc.), the Contractor shall obtain approval from the Public Services Director prior to saw cutting and removing pavement.

The cost of sawing asphalt or concrete shall be considered incidental to the removal operation and shall be included in the unit price bid for Grading.

SEEDING AND MULCHING

Description: The work covered by this special provision includes preparing seedbeds; furnishing, placing, and covering limestone, fertilizer, and seed; compacting seedbeds; furnishing, placing, and securing mulch; mowing; and other operations necessary for the permanent establishment of grasses from seed on shoulders, slopes, ditches, and on all earth areas disturbed by construction and on portions of areas seeded under previous contracts where, in the opinion of the Public Services Director, there is unsatisfactory vegetative cover.

Methods and Materials: All work covered in this special provision shall be in accordance with Section 1660, "Seeding and Mulching", of the Standard Specifications.

Measurement and Payment: There will be no separate measurement or payment for seeding and mulching. The costs associated with seeding and mulching the Project shall be included in the various bid items.

STANDARD SPECIFICATIONS

The current edition including revisions of the North Carolina Department of Transportation, Standard Specifications for Roads and Structures, hereinafter referred to as the "Standard Specifications" shall apply on all portions of the project unless otherwise specified herein.

SUBLETTING

The City reserves the right to waive the subcontracting limits set forth in Article 108-6 of the Standard Specifications whenever it is deemed to be in the best interest of the City. The limits can be waived only upon written approval from the City.

SUBSURFACE INVESTIGATION

The Contractor shall make his own subsurface investigations. Any information obtained by the City as a result of its own subsurface investigations will be made available upon request. This information (when available) is provided for informational purposes only and shall not relieve the Contractor from making his own investigations. The Contractor shall obtain all necessary permits prior to making any pavement cuts on existing streets.

TAX STATEMENT SUBMITTAL

1. All tax statement bodies and all signatures must be original. Photocopies of blank forms may be used, provided the document containing the information is original.
2. All tax statements must be signed by the Contractor/subcontractor's company officer submitting the statement and certified by a Notary Public. All tax statements must list in detail taxes paid by individual invoice. No lump sum, running total, or copies of previously reported statements will be accepted. Tax statements shall show North Carolina tax and Craven County tax paid.
3. A tax statement showing detailed amounts with "amounts previously reported" noted on the face will be accepted if they are original. This is the equivalent of a statement indicating "no taxes paid this period". All subcontractors for whom tax statements are included must be certified as such on the face of the Contractor's tax statement.
4. Tax statements (the State/County Sales/Use Tax Statement form) must always accompany a payment request for the related project. All final construction payment requests must have a final tax statement regardless of whether any taxes have been paid during the period in question. If no taxes have been paid, the detail page should simply state "0", "None", or "No taxes paid this period".

TAXES AND LICENSES

North Carolina sales and/or use taxes are applicable to purchases of building materials and other tangible personal property by Contractors for use in performing City contracts (see Tax Statement Submittal section of this contract). Use tax is also due on construction equipment brought into North Carolina for use in the performance of City contracts (N.C. Revenue Laws, G.S. 105-164.4 and G.S. 105-164.6). Contractors are liable for payment of applicable franchise, corporate income, license and withholding taxes (N.C. Revenue Laws, G.S. 105-122, G.S. 105-123, G.S. 105-163.2).

TERMINATION BY THE CITY FOR CAUSE

1. The City may terminate the Contract if the Contractor:
 - Persistently or repeatedly refuses or fails to supply enough properly skilled workers or proper materials;
 - Fails to make payment to subcontractors for materials or labor in accordance with the respective agreements between the Contractor and the subcontractors;
 - Persistently disregards laws, ordinances, or rules, regulations or orders of a public authority having jurisdiction; or
 - Otherwise is guilty of substantial breach of a provision of the Contract Documents.
2. When any of the above reasons exist, the City, upon certification by the Public Works Director that sufficient cause exists to justify such action, may without prejudice to any other rights or remedies of the City and after giving the Contractor and the Contractor's surety, if any, seven days written notice, terminate employment of the Contractor and may, subject to any prior rights of the surety:
 - Take possession of the site and all materials, equipment, tools and construction equipment and machinery thereon owned by the Contractor;
 - Accept assignment of subcontracts; and
 - Finish the work by whatever reasonable method the City may deem expedient. Upon request of the Contractor, the City shall furnish the Contractor a detailed accounting of the costs incurred by the Owner in finishing the work.
3. When the City terminates the Contract for one of the reasons stated above, the Contractor shall not be entitled to receive further payment until the work is finished.
 - The City shall have authority to terminate the Contract without additional authorization by City Board of Commissioners.
4. If the unpaid balance of the Contract Sum exceeds the costs of finishing the work, including compensation for the Engineer's services and expenses made necessary thereby, and other damages incurred by the City and not expressly waived, such expenses shall be paid to the

Contractor. If such costs and damages exceed the unpaid balance, the Contractor shall pay the difference to the City. The amount paid to the Contractor or the City, as the case may be, shall be certified by the Engineer, upon application, and this obligation for payment shall survive the termination of the Contract.

TERMINATION BY THE CITY FOR CONVENIENCE

1. The City may, at any time, terminate the Contract for the City's convenience and without cause. Upon written notice from the City of such termination for the City's convenience, the Contractor shall:

Cease operations as directed by the City in the notice;

Take actions necessary, or that the City may direct, for the protection and preservation of the work; and

Except for the work directed to be performed prior to the effective date of termination stated in the notice, terminate all existing subcontracts and purchase orders and enter into no further subcontracts and purchase orders.
2. The City shall have authority to terminate the Contract without additional authorization by City Board of Commissioners.
3. In case of such termination for the City's convenience, the Contractor shall be entitled to receive payment for work executed, and costs incurred by reason of such termination, along with reasonable overhead and profit for the completed work.

TREE PROTECTION

All tree root systems shall be protected during all phases of construction. There will be no separate measurement or payment for this work.

If the existing tree roots are the source of the pavement damage, the contractor shall be given direction on how to proceed with repairs and will be compensated in accordance with provisions in the contract.

UNDERCUT EXCAVATION

The work covered by this section consists of all elements of "Undercut Excavation" work covered by Section 226, "Comprehensive Grading" article 226-3, "Measurement and Payment".

The quantity of undercut excavation, measured as provided in Article 226-3, will be paid for at the contract unit price per cubic yard for "Undercut Excavation". No separate payment will be made for materials utilized in backfilling the undercut areas as payment at the contract unit price per cubic yard for "Undercut Excavation" will be full compensation for furnishing such material. Where the Contract does not include a line item for "Undercut Excavation", payment for such excavation will be made in accordance with Article 104-7, "Extra Work" of the Standard Specifications.

PROJECT SPECIAL PROVISIONS

ADJUSTMENT OF VALVE BOXES AND MANHOLES

The Contractor's attention is directed to Article 858-3 of the Standard Specifications. Cast iron or steel fittings will not be permitted for the adjustment of manholes and valve boxes on this project.

Payment for manhole and valve box adjustments will be made at the contract unit price for "Adjustment of Manhole" or "Adjustment of Valve Box" respectively.

Traffic shall be diverted around raised structures until completion of the work. Traffic control shall be as described elsewhere in these Special Provisions. The outside edge of raised structures shall be painted with orange paint to warn oncoming traffic.

Concrete placed around raised structures (see "Utility Adjustments for Resurfacing" in Appendix A) shall be high-early strength concrete. After adjusting structures to final grade, any material required to be excavated adjacent to the structure shall be replaced with concrete.

Structures exposed more than 2" by raising or milling operations shall have a temporary asphalt ramp placed around the structure (maximum slope 1/2"/ft). The temporary asphalt shall be removed just prior to final paving. Payment for temporary asphalt ramps shall be included in the unit price for adjusting the structure as described in Section 858.

ANTICIPATED WORK SCHEDULE

The Contractor will be required to provide a weekly schedule for streets to be resurfaced to allow the City departments sufficient time for re-scheduling of garbage collection. The Contractor shall supply updates to the schedule as necessary to coordinate this effort.

The Contractor is hereby notified that for any work to be acceptable to the City, a City Inspector must be present at all times. Any work performed in the absence of a City Inspector will not be considered for payment. Therefore, communication with the Public Works Director and / or City Inspectors is imperative.

ASPHALT CEMENT FOR PLANT MIX

There will be no separate measurement or payment for asphalt cement. All costs in connection therewith shall be included in the asphalt item in which asphalt cement is used.

ASPHALT SURFACE TREATMENT, MAT COAT, NO. 6 STONE

The Contractor's attention is directed to Section 660 of the Standard Specifications. A certification of compatibility of the asphalt (anionic emulsified asphalt RS-2 or cationic emulsified asphalt CRS-2) with the proposed aggregate shall be provided to the Public Works Director by the Contractor a minimum of three days prior to construction. The size of aggregate shall be No. 6 for all streets. All mat coat placed during the workday shall be covered with the resurfacing layer prior to ending the day's operation.

Liquid asphalt and aggregate shall be applied in accordance with the following schedule:

Mat Coat	Asphalt Rate	0.42 to 0.47 Gal./Sq. Yd.
	Application Temperature	150 F to 175 F
	Aggregate Size	No. 6
	Aggregate Rate	30 to 35 Lbs./Sq. Yd.

ASPHALT TESTING

Quality Management System for Asphalt Pavements, Article 609 of the Standard Specifications, shall apply on this project except for the provisions listed herein. Article 609-5 (D), Field Compaction Quality Control, shall be amended to require density tests at a rate of not less than two (2) tests per street or every 1,000 linear feet, whichever is greater. Cost for testing shall be included in the various asphalt bid items.

As part of the Quality Management System for Asphalt Pavements, all asphalt provided for this project must be provided by a NCDOT Certified Plant. The Contractor shall provide evidence of the plant's certification during the Pre-Construction Conference.

CONTRACT ADDITIONS

Street improvements are currently proposed for the list of streets in Appendix A.

The City reserves the right to add additional projects to be performed under this Contract up to 50% of the contract amount with or without consent of the Contractor, thereby increasing the estimated quantities of work shown in the Proposal. Additions beyond 50% of the contract amount shall be approved by both the City and the Contractor. Payment for said additional work will be based on unit prices submitted in the Proposal. Before starting additional work, the Contractor will be required to furnish a 100% performance bond and a 100% payment bond covering each addition to the Contract and bear all expense in connection with such bond. The maximum total increase in cost of the additional work will not exceed 100% of the cost of the original bid amount as based on the estimated quantities in the Proposal. Any and all additions to this Contract will be subject to all of the terms and conditions of this bid.

CONTRACT PERIOD

The Contract Period of Performance is ninety (90) days. The Contract period will begin upon date listed on the Notice to Proceed, the date on the Notice to Proceed will be based on NC DOT 610-4 Weather, Temperature, and Seasonal limitations for Producing and Placing Asphalt Mixtures.

LIQUIDATED DAMAGES

Liquidated Damages will be assessed at the rate of **\$1000** per calendar day for failure to complete the Project within the Contract Period.

LOCATION OF THE PROJECT

See the "Havelock 2022 Paving Maintenance Map" included in Appendix A.

MILLING ASPHALT PAVEMENT

Incidental Milling: All milling required at intersections or other tie ins to existing pavement will be paid at the contract unit price for Incidental Milling. Tie ins to existing pavement shall be smooth and on a uniform slope with no abrupt change in elevation.

Milling 1.5": The Contractor is advised to inspect streets for the purpose of milling where designated by the Public Works Director. These streets shall have profile milling with milling at the existing curb to a depth of 1.5" and tapering to the existing pavement 7' from the existing curb. All milling will be paid for at the contract unit price for Milling Asphalt Pavement 1.5" Depth per square yard. When a street has both patching and milling, the milling operation is to be accomplished and completed prior to any patching taking place.

PAVEMENT RESURFACING

Pavement resurfacing will not be allowed between the hours of 8:00 p.m. and 8:00 a.m. nor at any time on weekends or holidays. All lanes shall be fully opened by 8:00 p.m. each day following paving resurfacing operations.

Driveways on streets with no curb and gutter: A taper shall be constructed from the existing edge of pavement 4' into the existing asphalt or concrete driveway. The existing driveway shall receive a tack coat prior to the construction of the taper.

PORTABLE CONSTRUCTION ZONE TRAFFIC CONTROL DEVICES

In addition to the traffic control devices listed in Section 1089 of the Standard Specifications, the Contractor shall provide a 48" x 48" black letters on white background signs with the following information: "NO PARKING, STREET RESURFACING WITHIN NEXT 24 HOURS". The signs are to be placed at the

beginning and end of each street which is to be resurfaced 24 hours prior to beginning work. "LOW SHOULDER" signs shall be installed if so directed. Payment for signs shall be included in the various pay items with no separate payment.

TRAFFIC CONTROL

1.0 Beginning Work and Street Closings:

The Contractor is responsible for notifying the Street Department of any work where the number of travel lanes is reduced from normal conditions.

The Contractor shall install the project advanced warning signs. These signs shall be in place for one week before construction activity begins. The Contractor shall begin construction activity on a street the scheduled date of the closing of the travel lane.

During daily construction work hours, the Contractor will maintain at least one lane of traffic. During periods of construction inactivity all lanes of traffic will be open unless otherwise noted in the specifications or specified by the Public Works Director.

2.0 Right-of-Way Use Permit:

The Contractor will not be responsible for obtaining the Right-of-Way Use Permit(s) from NCDOT for approval to work in the street rights-of-way as all work is planned to be conducted on City of Havelock streets. Any required permit(s) will be obtained by the City of Havelock.

3.0 Traffic Control Plan:

Traffic Control will be performed by the Contractor based upon the current edition of the Manual on Uniform Traffic Control Devices (MUTCD).

All traffic control devices and procedures shall conform to the requirements of the current edition of the MUTCD, the current edition of the North Carolina Department of Transportation (NCDOT) Supplement to the Manual on Uniform Traffic Control Devices for Streets and Highways, the NCDOT Roadway Standard Drawings, and the current edition of the NCDOT Standard Specifications for Roads and Structures.

The Contractor shall maintain the traffic control as described herein unless the Contractor submits an alternate traffic control plan to the Public Works Director and it is approved by the Public Works Director. The Public Works Director may direct the Contractor to modify traffic control if, in the Public Works Director's opinion, traffic is not moving safely or efficiently.

4.0 Maintenance of Traffic:

The Contractor shall maintain all travel lanes in accordance with the MUTCD.

Construction or maintenance work at school zones which involve closure of a lane of traffic will not be allowed during the peak flow hours of 7 a.m. to 9 a.m. and 2 p.m. to 4 p.m. unless otherwise specified in the contract documents or specifically approved otherwise.

The Contractor shall use flagger control in accordance with the MUTCD.

In areas of drop-offs and low shoulders the Contractor shall backfill up to the edge and elevation of the existing pavement.

The Contractor will be required to maintain ingress and egress to all businesses and dwellings, and easy access to fire hydrants.

The Contractor shall not work on both sides of the road simultaneously within the same area.

The Contractor shall provide adequate drainage under driveways and within the project area for the duration of the project.

The Contractor shall mark all hazards within the project limits with well-maintained signs, barricades, warning and/or channelizing devices.

5.0 Traffic Control Devices:

The Contractor shall furnish, install, operate, relocate, maintain and remove all temporary traffic control devices necessary for controlling traffic. The Contractor shall notify the City's inspector regarding conflicting permanent signs. All construction signs and barricades shall remain in place until the appropriate permanent signs and pavement markings are installed.

6.0 Pedestrian Considerations:

The Contractor shall accommodate the needs of all pedestrians.

7.0 Equipment and Material Storage:

During periods of construction inactivity, all construction materials and equipment shall be stored by the Contractor in a safe manner.

8.0 Traffic Signals:

The Contractor shall not disturb any traffic signal equipment unless otherwise directed to do so by the Public Services Director.

9.0 Excavations and Trenches:

Excavations and trenches which cannot be properly backfilled and patched prior to the end of the work day shall be secured.

10.0 Measurement:

There will be no separate measurement made for Traffic Control.

11.0 Payment:

There will be no separate payment for traffic control. Costs for traffic control shall be included with the various pay items.

(Page intentionally left blank)

SPECIAL PROVISION PAY ITEMS

SP-1, GRADING

1.0 Description:

The work covered by this section consists of all elements of work covered by Section 200, "Clearing and Grubbing"; Section 225, "Roadway Excavation"; Section 230, "Borrow Excavation"; Section 235, "Embankments"; Section 240, "Ditch Excavation"; Section 250, "Removal of Existing Pavement"; Section 260, "Proof Rolling"; Section 412, "Unclassified Structure Excavation"; Section 500, "Fine Grading Subgrade, Shoulders and Ditches"; Section 560, "Shoulder Construction"; and the work items listed below, except that the provisions of the above referenced sections pertaining to method of measurement, basis of payment, or compensation will not apply.

- a. Tree Protection: Any tree protection anticipated by the Contractor shall be included in this item.
- b. Saw Cutting: The Contractor shall make a determination of the saw cutting needed to build the project and that work shall be included in this item.
- c. Contractor shall provide construction stakes, lines and grades necessary to construct the proposed project.
- d. Miscellaneous Concrete or Asphalt Removal and Disposal: The Contractor shall remove and dispose of Miscellaneous Concrete or Asphalt (existing concrete or asphalt driveways, streets, pads, slabs, walks etc.) that must be removed and disposed of to build this project.
- e. Erosion Control: Includes but is not limited to furnishing, installing, and maintaining, silt fence, diversion ditches, rock inlet sediment traps, rock check dams, temporary rock construction entrances, screenings under excavated material if to be placed on existing pavement, and all other erosion control measures required by current ordinances, project permitting, and the Contractor's means and methods.
- f. Seeding and Mulching: The Contractor shall be responsible for all Seeding and Mulching required to complete this project in accordance with the specifications. Seeded areas must exhibit a full stand of grass at the end of the warranty period.
- g. Mail Boxes and Site Amenities: Remove, protect, and reset mail boxes and site amenities.
- h. Traffic Control: The Contractor shall provide traffic control necessary to complete the work in accordance with the project specifications.

2.0 Construction Methods:

Construction Methods will be per section 226 "COMPREHENSIVE GRADING" subarticle 226-2 "CONSTRUCTION METHODS" of the standard specifications.

3.0 Measurement and Payment:

Measurement will be per section 226 "COMPREHENSIVE GRADING" subarticle 226-3 "MEASUREMENT AND PAYMENT" of the standard specifications.

There will be **no separate measurement or payment** for those items listed in this specification, SP-1 "GRADING".

Payment will be made under:

GRADING.....LS

SP-5, ASPHALT COURSE

1.0 Description:

Perform asphalt surface course installation in accordance with Section 610 of the Standard Specifications. Assure temperature of the mixture immediately before discharge from the hauling vehicle is within a tolerance of +15°F to -25°F of the specified JMF temperature. The temperature of the asphalt surface course on the truck shall be measured with a probe thermometer only. Asphalt surface course must be placed and compacted before dropping below 185°F.

2.0 Materials:

Asphalt for surface course shall be S-9.5B in accordance with Section 610 of the Standard Specifications.

3.0 Measurement:

Asphalt course will be measured per square yard of surface course that has been completed and accepted. Thickness specified is to be measured after installation and completion of compaction.

4.0 Payment:

Payment for asphalt course shall be inclusive of all work items described in Section 610. Payment will be made under:

1.5" ASPHALT SURFACE COURSE TYPE S-9.5B SY

SP-6, SHOULDER REPAIR

1.0 Description:

Where designated by the Public Works Director or approved representative, the Contractor shall backfill with topsoil along the edge of pavement after final paving. The backfill shall be a minimum of 12" in width tapered from the edge of pavement to the existing ground and shall be lightly compacted. The backfill shall be limed, fertilized, seeded, and mulched in accordance with the specifications. Seeded areas shall exhibit a full stand of grass at the end of the warranty period.

Additionally, and where the elevation of the existing shoulder exceeds the finished edge of pavement after final paving and as designated by the Public Works Director or approved representative, the Contractor shall remove the existing grass and topsoil as per the "Shoulder Typical Section" in Appendix A. The exposed topsoil shall be limed, fertilized, seeded, and mulched in accordance with the specifications. Seeded areas shall exhibit a full stand of grass at the end of the warranty period.

2.0 Materials:

Soil used as backfill shall be natural, fertile, agricultural topsoil capable of sustaining vigorous plant growth. Topsoil shall be free of stones, lumps, roots, sticks, or other extraneous matter. Soil to be used as backfill must be approved by the City prior to placement in order to judge the suitability of the material for the intended use. Materials for seeding and mulching shall be as listed in the specifications.

3.0 Measurement:

Shoulder repair will be measured per linear foot of shoulder repair that has been installed and accepted.

4.0 Payment:

Payment for shoulder repair shall be inclusive of all labor, materials, and workmanship to place the soil backfill or remove the excess grass and topsoil, seeding, and mulching.

Payment will be made under:

SHOULDER REPAIR..... LF

ITEMIZED PROPOSAL SECTION

City of Havelock
P.O. Box 368
Havelock, North Carolina 28532

PROJECT NAME: Havelock 2022 Paving Maintenance

The undersigned, having carefully examined the site and familiarized himself with the existing conditions on the Project area affecting the cost of work and with the Contract Documents, the form of Proposal, the form of Bid Bond, form of Contract, Addenda (if any), Standard Specifications, Special Provisions, form of Performance Bond and Payment Bond, and details/drawings, as prepared by the City of Havelock, hereby proposes to furnish all supervision, labor, equipment, materials and services, including all utility and transportation services required to construct and complete the Project in accordance with the above listed documents at and for the Contract Sum as determined by the unit or lump sum prices bid for work in place for the following items and quantities.

The quantities shown in the itemized proposal are considered to be approximate only and are given as the basis for comparison of bids. The City of Havelock may increase or decrease the amount of any item or portion of items as may be deemed necessary or expedient. An increase or decrease in the quantity of any item will not be regarded as sufficient grounds for an increase or decrease in the unit prices, nor in the time allowed for the completion of the work, except as provided for in the Contract.

FOR BIDS EQUAL TO OR EXCEEDING \$100,000:

Accompanying this Proposal is a Surety Bond with Warrant of Attorney to confess judgment, or other satisfactory surety, or certified check drawn on a responsible banking institute, payable to the order of the City of Havelock for five percent (5%) of the total price bid, which deposit shall be forfeited as liquidated damages in case this Proposal is accepted and the undersigned shall fail to execute a contract with necessary bond for the performance of said contract with the City of Havelock, under the conditions of this Proposal, within 14 calendar days after the notice of award is received by him, as provided in the Standard Specifications; otherwise, said deposit is to be returned to the undersigned.

ACKNOWLEDGMENT OF ADDENDA

The Bidder hereby acknowledges receipt of any addenda

NUMBER: _____ DATE: _____ INITIAL: _____

NUMBER: _____ DATE: _____ INITIAL: _____

NUMBER: _____ DATE: _____ INITIAL: _____

NUMBER: _____ DATE: _____ INITIAL: _____

ITEMIZED PROPOSAL

PROJECT: Havelock 2022 Street Improvements						
(Section Code Numbers refer to appropriate section of the 2012 Revised Standard Specifications of the North Carolina Departments of Transportation. SP refers to the appropriate section of these specifications.)						
Item No.	Sect. No.	Item Description	Quantity and Unit		Unit Price Bid Dollars	Amount Bid Dollars
1	800	Mobilization	3	LS		
2	SP-1	Grading	/	LS		
3	607	Incidental Milling	9974	SY		
4	607	Milling Asphalt Pavement, 1.5" Depth	290	SY		
5	SP-5	1.5" Asphalt Surface Course Type S 9.5 B	59,447	SY		
6	858	Adjustment of Valve Boxes	15	EA		
7	858	Adjustment of Manholes	14	EA		
8	SP-7	Shoulder Repair	23,505	LF		
9	MUTCD	Traffic Control	20	Day		
					Subtotal	
					10% Contingency	
					Total Amount Bid	

EXECUTION OF BID

A CONTRACT FOR THE CONSTRUCTION OF:

PROJECT NAME: HAVELOCK 2022 PAVING MAINTENANCE

The person executing the Bid, on behalf of the Bidder, being first duly sworn, deposes and says that:

- (1) It is the intent of the Bidder to enter into this Contract to furnish materials, labor, and equipment required to perform all work specified in accordance with the instructions, terms, conditions, provisions, specifications, and all other Contract Documents incorporated into this Invitation to Bid;
- (2) He/she is fully informed regarding the preparation and contents of the attached Proposal and of all pertinent circumstances regarding such Proposal;
- (3) Neither he/she, nor any official, agent or employee of the Bidder has entered into any agreement, participated in any collusion, or otherwise taken any action which is a restraint of free competitive bidding in connection with is Bid;
- (4) He/she will not discriminate against any employee or applicant for employment because of race, color, religion, sex, national origin, disability, or veteran's status.

Type of Bidder: Sole Proprietor Partnership Limited Liability Company Corporation
 Joint Venture

(Check appropriate box)

	BIDDER #1	BIDDER #2 <i>(If a Joint Venture or Partnership)</i>
Name	_____	_____
Address	_____	_____
	_____	_____
Phone	_____	_____
Fax	_____	_____
Printed Name	_____	_____
SIGNATURE	_____	_____
Title	_____	_____
NC General Contractor's License Number	_____	_____
Classification	_____	_____
Limits	_____	_____

Subscribed and sworn before me
this ___ day of _____, 20__

Subscribed and sworn before me
this ___ day of _____, 20__

Signature

Signature

My commission expires _____

My commission expires _____

BONDS AND CERTIFIED POWER OF ATTORNEY

(Attach Bond and Power of Attorney to this sheet)

Note: Attorneys-in-fact who sign bonds must file with each bond a certified and effectively dated copy of their power of attorney.

FORMS

CONTRACTOR'S AFFIDAVIT RELEASE AND WAIVER OF CLAIM

STATE OF _____ COUNTY OF _____

_____, of
(Name) (Title)

_____, being first duly sworn, deposes and says
that:
(Contractor)

The undersigned is authorized to execute this Affidavit, Release and Waiver of Claim on behalf of the Contractor and that he has personal knowledge of all facts set forth herein;

This Affidavit, Release and Waiver of Claim is made concerning the construction of the following;

Project: _____ Project No.: _____

All payrolls, material bills, sales tax, social security tax, state and federal unemployment insurance, and all other liabilities and taxes owed by the Contractor and arising in any manner from the above-described project have been paid in full;

No claim or lien exists in favor of any supplier of materials or labor or in favor of any subcontractor furnishing materials or labor on the above-described project;

Notwithstanding the foregoing, if the City of Havelock, or property of the City of Havelock, is subject to any claim or lien that arises in any manner from the failure of the Contractor to pay any liability described above, the Contractor will indemnify and hold the City of Havelock harmless for any amount that the City of Havelock is required to pay to discharge such lien or settle such claim and, further, will pay the City of Havelock's expenses, costs, and attorney fees incurred in connection therewith;

All claims, suits, and proceedings of every name, description, or nature arising out of the above project against the City of Havelock, its officers, employees, and agents have been settled;

The Contractor releases and waives any and all claims of every type and description that the Contractor may have against the City of Havelock arising in any manner from the construction of the above-described project.

By: _____ Date: _____

Title: _____

Sworn to and subscribed before me this _____ day of

_____, 20_____

Notary Public

My commission expires _____

CONTRACTOR'S AFFIDAVIT OF PAYMENT OF DEBTS AND CLAIMS

To: (Owner)

Contract For:

Project Name and Address:

Contract Date:

State of North Carolina
County of

The undersigned hereby certifies that, except as listed below, he has paid in full or has otherwise satisfied all obligations for all materials and equipment furnished, for all work, labor, and services performed, for all sub-contractor's services and for all known indebtedness and claims against the Contractor for damages arising in any manner in connection with the performance of the Contract referenced above for which the Owner of his property might in any way be held responsible.

Exceptions:

Contractor:

Address:

By:

Subscribed and sworn to before me this _____ day of _____, 20____

Notary Public:

My Commission Expires:

AGREEMENT

AGREEMENT

THIS CONTRACT made and executed in four (4) copies this ____ day of _____, 20____, by and between the City of Havelock, NC, and Municipal Corporation hereinafter designated as the City, and _____, hereinafter designated as the Contractor.

WITNESSETH: That the parties hereto, each in consideration of the Agreements on the part of the other herein contained, have mutually agreed and hereby mutually agree, the City for itself and its successors and the Contractor for itself, himself, or themselves and its successors, his or their executors, administrators and assigns as follows:

Article 1. DESCRIPTION. Under this Agreement and Contract, the Contractor shall construct Havelock 2022 Paving Maintenance.

Article 2. In consideration of the payments to be made as hereinafter provided, and the performance of the City of all of the matters and things to be performed by the City and herein provided; the Contractor agrees, at his own sole cost and expense, to perform all the labor and services and to furnish all the labor and materials, plant and equipment necessary to complete, and to complete in good, substantial, workmanlike and approved manner, the work described under Article 1 hereof, within the time specified and in accordance with the terms, conditions and provisions of this Contract and with the instructions, orders and directions of the public services director made in accordance with this Contract.

Article 3. The City agrees to pay and the Contractor agrees to accept as full compensation for all work done, and materials furnished, and for materials, equipment and supplies sold, and also for all costs and expenses incurred, and loss or damages sustained by reason of the action of the elements, or growing out of the nature of the work, and for all risk of unforeseen obstruction or difficulty encountered in the prosecution of the work, and for all risks of every description connected with the work, and for all expenses incurred by, or in consequence of, the suspension or discontinuance of the work as herein specified, and for faithfully completing the work and the whole thereof as herein provided, and for maintaining the work in good condition until the final payment is made, the prices stipulated in the Bid hereto attached.

Article 4. The following documents shall constitute integral parts of the agreement, the whole to be collectively known and referred to as the Contract Documents or Contract Advertisement: Invitation to Bid, Itemized Proposal, Agreement, Standard Special Provisions, Project Special Provisions, Contract Drawings, Addenda, and all interpretations of addenda to the Contract Documents issued by the City or the Engineer with the approval of the City.

The Table of Contents, Headings and Titles contained herein and in said documents are solely to facilitate reference to various provisions of the Contract Documents and in no way affect, limit or cast light on the interpretation of the provisions to which they refer.

Article 5. If the Contractor shall fail to comply with any of the terms, conditions, provisions or stipulations of this Contract, according to the true intent and meaning thereof, then the City may make use of any or all remedies provided in that behalf in the Contract and shall have the right and power to proceed in accordance with the provisions thereof.

IN WITNESS WHEREOF, the parties of this Agreement have hereunto set their hands and seals and have executed this Agreement, in four copies the day and year first above written.

CONTRACTOR:

By: _____

Name: _____

Title: _____

(Seal)

ATTEST:

Name: _____

Title: _____

CITY:

City of Havelock _____

By: _____

Name: _____

Title: _____

(Seal)

ATTEST:

Name: _____

Title: City Clerk _____

This instrument has been pre-audited in the manner required by the local Government Budget and Fiscal Control Act.

Finance Director
City of Havelock, North Carolina

**AGREEMENT
(CERTIFICATE OF CITY'S ATTORNEY)**

The undersigned as the duly authorized attorney for the City, does hereby certify that:

I have examined the Contract, the surety bond(s) and the policies or other evidence of insurance coverage, and in the manner of execution thereof. In my opinion said surety bonds and insurance coverage are in compliance with the Contract and are adequate in form, substance and amount to protect the various interests of the City in connection with the Contract. I am of further opinion that the Contract, the said surety bond(s) and policies or other evidence of insurance coverage have been duly executed by the proper parties thereto acting through their duly authorized representatives; that said representatives have full power and authority to execute said agreements on behalf of the respective parties named thereon; and that each of the aforementioned agreements constitutes valid and legally binding obligations upon the parties executing the same in accordance with the terms, conditions and provisions thereof.

Date

City's Attorney

AGREEMENT
(Attach Insurance Certificates Here)

AGREEMENT
(Attach Performance Bond Here)

AGREEMENT
(Attach Labor and Material Bond Here)

APPENDIX A

- **Havelock 2022 Paving Maintenance Street List**
- **Havelock 2022 Paving Maintenance Map**
- **Detail Drawings**
 - **Utility Adjustments for Resurfacing**
 - **Resurfacing and Milling Typical Sections**
 - **Shoulder Typical Section**
- **Quality Management System (QMS) Forms**
 - **Daily Paving Operation Evaluation Form**

STREET	From	To	Manholes (EA)	Valves (EA)	Milling Incidental (SY)	Length (Mile)	Resurfacing (SY)	Resurface Depth (Inch)	Shoulder Repair (LF)	Milling Asphalt Pavement, 1.5" Depth (SY)
Little John Ln	Devonshire Dr	Friar			18	0.08	885	1.5	796	
Dogwood St	Fleetwood St	E. Main St	1		151	0.14	1,642	1.5	1178	
Evelyn Ct	Webb Blvd	Cul-De-Sac			15	0.13	2,067	1.5	1478	
Pirates Ln	Tarheel	Wolfpack	1		30	0.17	2,392	1.5	1794	
Pirates Ln	Wolfpack	McCotter			28	0.06	824	1.5	620	
Rams Rd	Tarheel	Cul-De-Sac	1		15	0.19	2,817	1.5	2040	
Rams Rd	Rams	Cul-De-Sac			-	0.01	622	1.5	251	
Blarney Ct	Manchester Rd	Cul-De-Sac			18	0.05	854	1.5	512	
Forest Hill Dr	Fleetwood St	Webb Blvd		2	25	0.21	2,226	1.5	2226	
Poplar Rd	Woodhaven Dr	Cul-De-Sac			520	0.07	1,211	1.5		
Little John Ln	Devonshire Dr	East Avon PL			15	0.17	1,980	1.5	1782	
Lee Dr	Manila St	Begin Curb & Gutter			14	0.03	492	1.5	316	
Lee Dr	Coyote Trl	Timber Dr			538	0.11	1,795	1.5		
Bobcat Cr	Timber Dr	Cul-De-Sac	1		512	0.04	848	1.5		
Tall Pine Rd	Forest View Dr	Wildwood Rd			361	0.07	1031	1.5		
Timber Ct	Timber Dr	Cul-De-Sac	1		550	0.05	907	1.5		
Wildwood Rd	Woodhaven Dr	Tallpine Rd			1,024	0.22	2,944	1.5		
Foxlair Ln	Gray Fox Rd	Circle			646	0.13	2,106	1.5		
S. Forest Cir	S. Forest Dr	Cul-De-Sac	1		268	0.05	991	1.5		
S. Forest Dr	Hollywood Blvd	S. Forest Cir			220	0.05	759	1.5		
S. Forest Dr	S. Forest Cir	Hollywood Blvd			1,496	0.32	5,236	1.5		
S. Forest Dr	Shepard St	S. Forest Cir			346	0.08	1,210	1.5		
Stone Bridge	Hwy 70 W	Stonebridge Sq		5	75	0.01	140	1.5		
Gene Dr	Rice Ln	Kyle Dr	2	2	29	0.12	1,675	1.5	1256	

Beechwood Dr	Cul-De-Sac	Rice Ln	1	3	27	0.07	955	1.5	720	
Lewis Ct	Cul-De-Sac	Keith Dr			25	0.04	734	1.5	502	
Tarheel Dr	Webb Blvd	McCotter Blvd		2	30	0.28	3,843	1.5	2882	
Timber Dr	Hwy 70 W	Bobcat Cir			327	0.07	1,145	1.5		
Timber Dr	Bobcat Cir	Timber Ct			250	0.05	874	1.5		
Timber Dr	Timber Ct	Lee Dr			269	0.06	739	1.5		
Hayden Ct	Rice Ln	Cul-De-Sac			15	0.07	1,134	1.5	704	
Leslie Ln	Forest Hill Dr	Cul-De-Sac			18	0.23	3,444	1.5	2510	
Pinedale Rd	Woodhaven Dr	Tallpine Rd	3	1	1,042	0.22	2,908	1.5		
Kyle Dr	McCotter Blvd	Cul-De-Sac	1		15	0.11	1,678	1.5	1112	
Poplar Rd	Woodhaven Dr	Tallpine Rd			1,028	0.21	2,989	1.5		
Derrick Cr	Methodist Dr	Cul-De-Sac	1		14	0.07	1,060	1.5	826	
Nottingham	Berkshire Dr	650' East				0.12	290	1.5		290
		Totals =	14	15	9974	4.16	59,447		23505	290

Havelock
2022 Paving Maintenance
Street List and Approximate Quantities

2022 Paving Maintenance Project

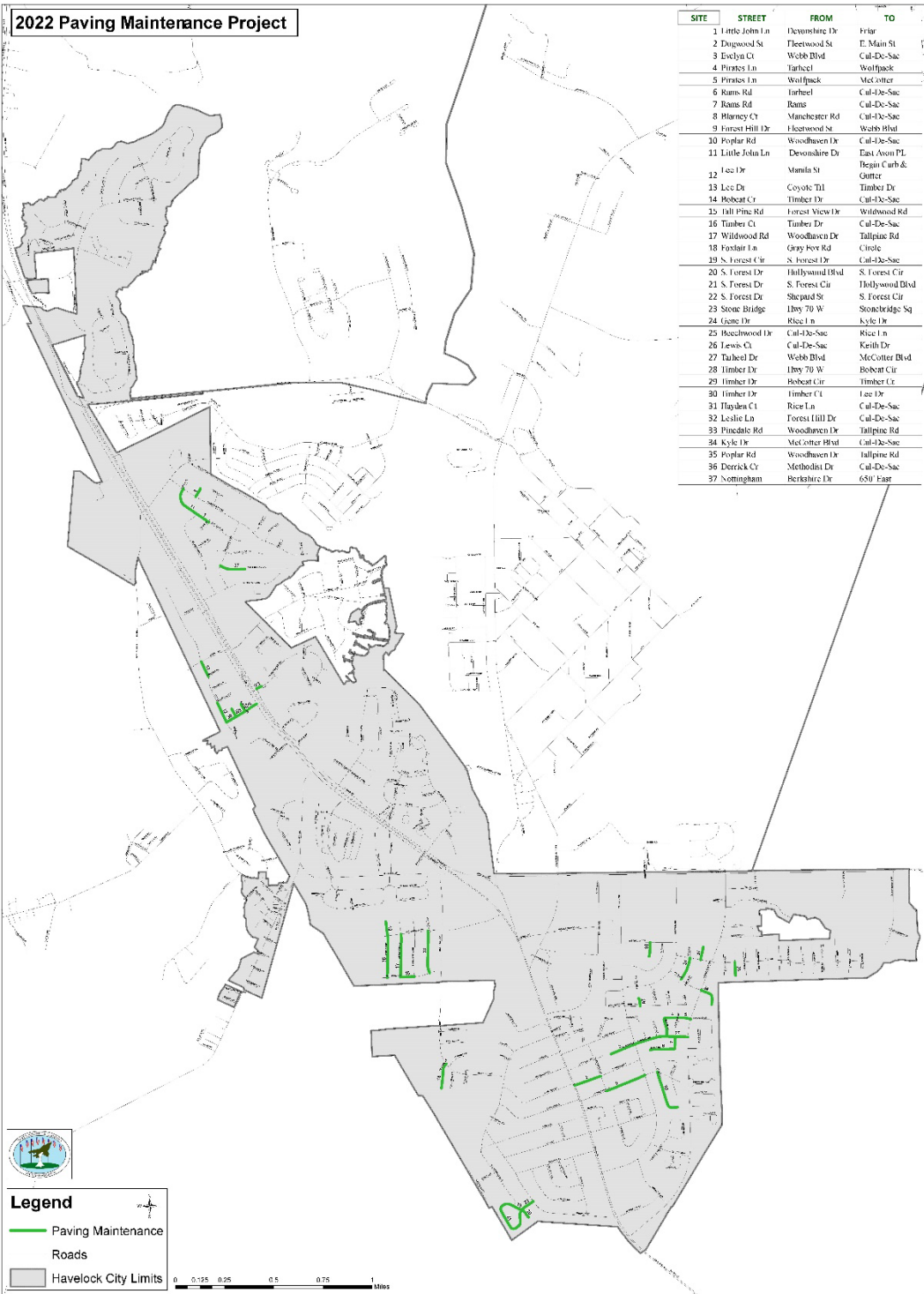

SITE	STREET	FROM	TO
1	Little John Ln	Devonshire Dr	Prfar
2	Dougwood St	Fleetwood St	E. Main St
3	Evilyn Ct	Webb Blvd	Cal-De-Sac
4	Prattys Ln	Tarheel	Walpole
5	Prattys Ln	Walpole	McJetter
6	Rams Rd	Tarheel	Cal-De-Sac
7	Rams Rd	Rams	Cal-De-Sac
8	Blaney Ct	Manchester Rd	Cal-De-Sac
9	Forrest Hill Dr	Fleetwood St	Webb Blvd
10	Poplar Rd	Woodhaven Dr	Cal-De-Sac
11	Little John Ln	Devonshire Dr	East Avon PL Beam Car & Gutter
12	Lee Dr	Mania St	Timber Dr
13	Lee Dr	Coyote Trl	Timber Dr
14	Hobcat Cr	Timber Dr	Cal-De-Sac
15	Hill Pine Rd	Forrest View Dr	Withwood Rd
16	Tanber Ct	Timber Dr	Cal-De-Sac
17	Wildwood Rd	Woodhaven Dr	Tallpine Rd
18	Foxstar Ln	Gray Foot Rd	Circle
19	S. Forest Cir	S. Forest Cir	Cal-De-Sac
20	S. Forest Dr	Hollywood Blvd	S. Forest Cir
21	S. Forest Dr	S. Forest Cir	Hollywood Blvd
22	S. Forest Dr	Shepard St	S. Forest Cir
23	Stone Bridge	Dwy 70 W	Stonebridge Sq
24	Legs Dr	Rise Ln	Kyle Dr
25	Beechwood Dr	Cal-De-Sac	Rise Ln
26	Lewis Ct	Cal-De-Sac	Keith Dr
27	Talbot Dr	Webb Blvd	McCotter Blvd
28	Timber Dr	Dwy 70 W	Hobcat Cir
29	Timber Dr	Hobcat Cir	Timber Ct
30	Timber Dr	Timber Ct	Lee Dr
31	Hayden Ct	Rise Ln	Cal-De-Sac
32	Leslie Ln	Forrest Hill Dr	Cal-De-Sac
33	Pinevale Rd	Woodhaven Dr	Tallpine Rd
34	Kyle Dr	McJetter Blvd	Cal-De-Sac
35	Poplar Rd	Woodhaven Dr	Tallpine Rd
36	Derrick Cr	Methodist Dr	Cal-De-Sac
37	Nottingham	Berkshire Dr	650' East



Legend

- Paving Maintenance
- Roads
- Havelock City Limits



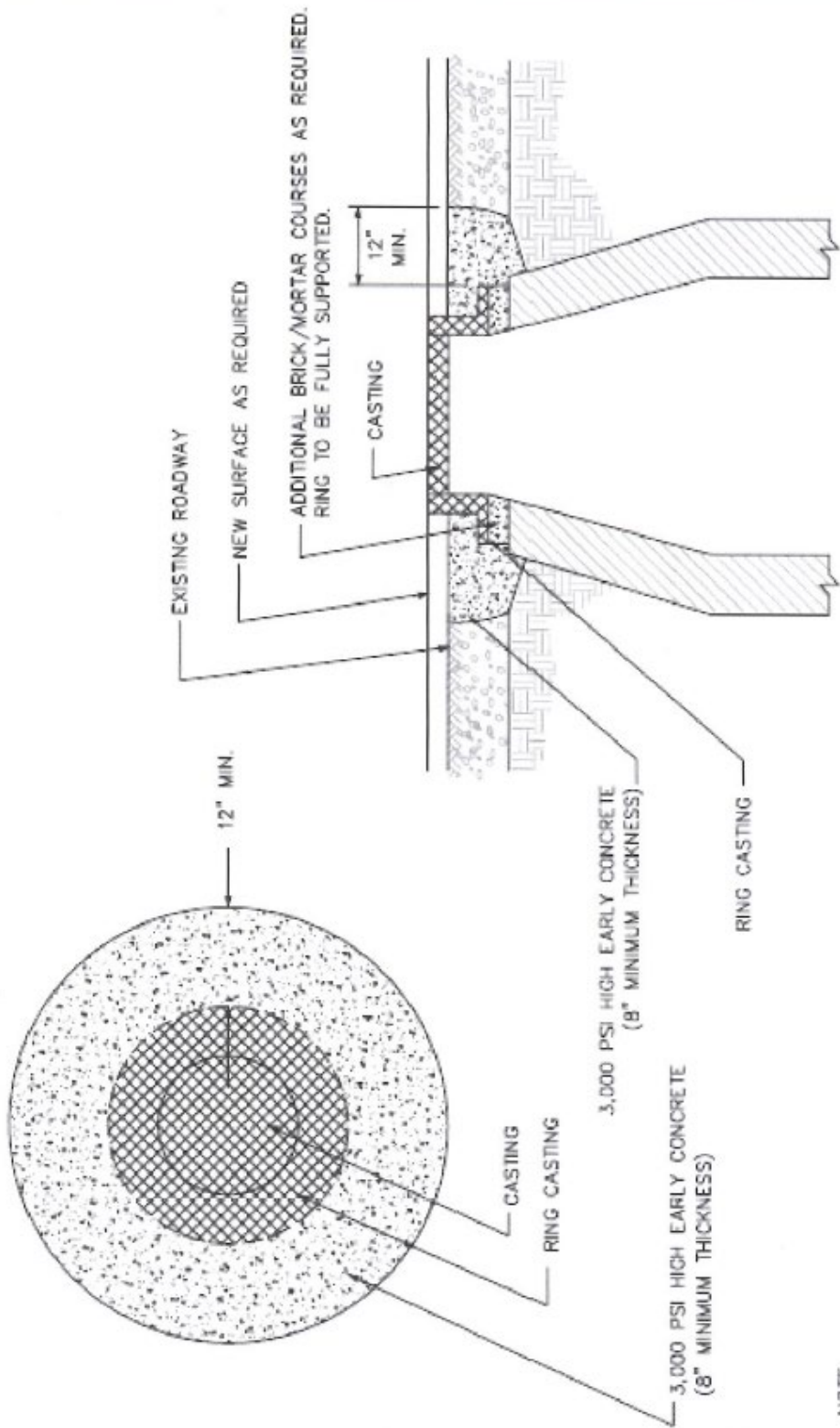

NOTE:
 SAME DIMENSIONS AND MATERIALS
 FOR ALL VALVE BOXES AND MANHOLES

September 2022

UTILITY ADJUSTMENTS FOR RESURFACING

NOT TO SCALE

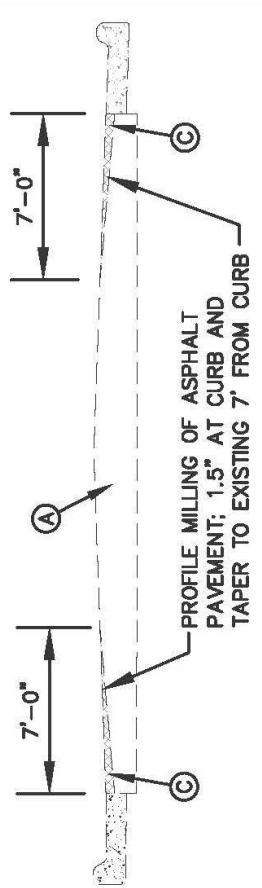

MILLING TYPICAL SECTION #1

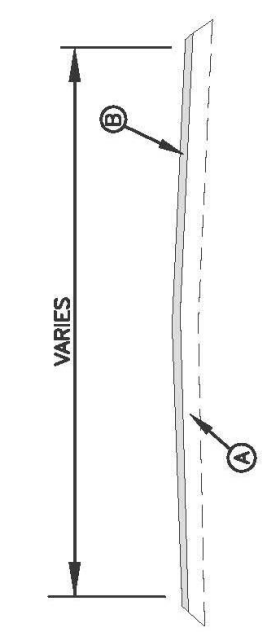

RESURFACING TYPICAL SECTION #1

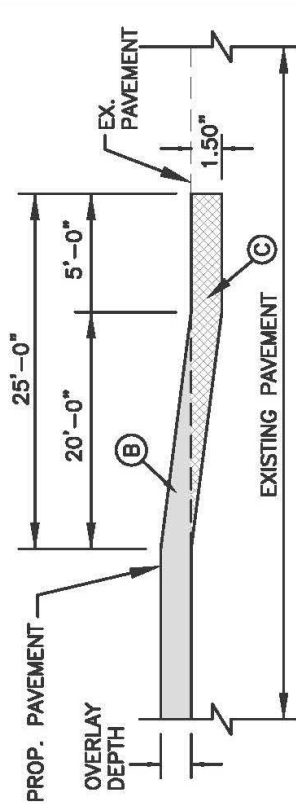

MILLING TYPICAL SECTION #2

THIS TYPICAL SECTION SHALL BE USED WHERE PROPOSED ROADWAY TIES TO EXISTING ROADWAY

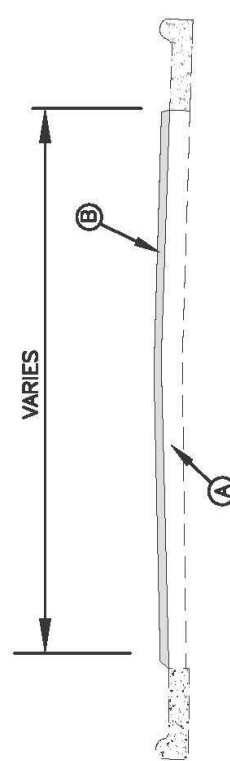

RESURFACING TYPICAL SECTION #2

RESURFACING AND MILLING SCHEDULE

- (A) EXISTING PAVEMENT
- (B) BITUMINOUS CONCRETE SURFACE COURSE, TYPE S-9.5B, AT AN AVERAGE RATE OF 112 POUNDS PER SQUARE YARD PER INCH. MINIMUM COMPACTED THICKNESS OF SURFACE COURSE SHALL BE NOT LESS THAN 1.5 INCHES.
- (C) PROPOSED ASPHALT MILLING

September 2022

RESURFACING AND MILLING TYPICAL SECTIONS

NOT TO SCALE

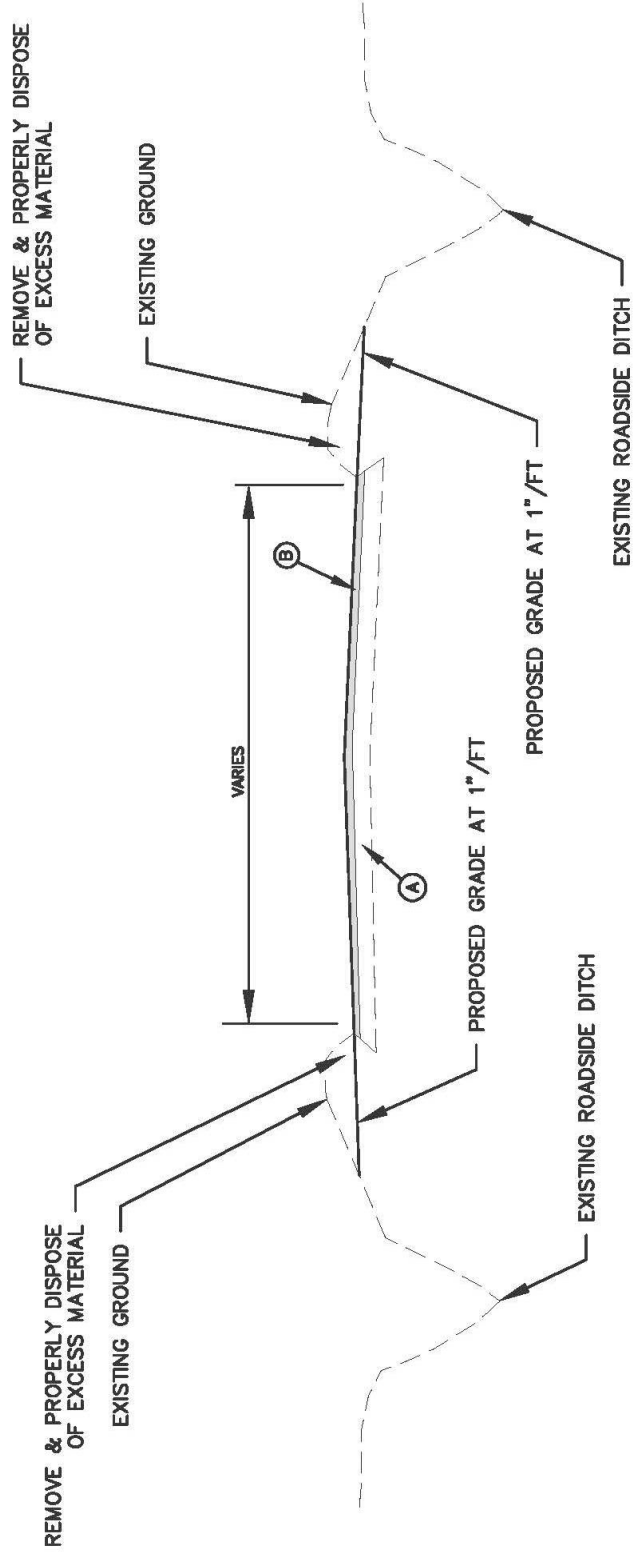

RESURFACING SCHEDULE

- (A) EXISTING PAVEMENT
- (B) BITUMINOUS CONCRETE SURFACE COURSE, TYPE S-9.5B, AT AN AVERAGE RATE OF 112 POUNDS PER SQUARE YARD PER INCH. MINIMUM COMPACTED THICKNESS OF SURFACE COURSE SHALL BE NOT LESS THAN 1.5 INCHES.

September
2022

SHOULDER TYPICAL SECTION

NOT TO SCALE

North Carolina Department of Transportation Roadway Technician's
Daily Paving Operation Evaluation Form

Date: _____ Type Mix: _____

Contractor: _____ Project: _____

	Circle		Remarks/Comments
Is tack being applied uniformly? Verify proper rate? Application Temp?	Yes	No	
Is stringline being placed for alignment?	Yes	No	
Are haul trucks raising bed before releasing gate?	Yes	No	
Are trucks cleaning out in front of paver?	Yes	No	
Is paver engaging truck - not trucks bumping paver?	Yes	No	
Is paver folding hopper wing only when the hopper is relatively full?	Yes	No	
Is hopper remaining 1/3 full?	Yes	No	
Is paving at consistent speed to match delivery rate?	Yes	No	
Is head of material kept level w/ auger shaft (+/- 1")?	Yes	No	
Is segregation observed in delivery and placement of material?	Yes	No	
Are automatic controls used properly to provide grade and cross-slope?	Yes	No	
s smoothness and texture of mat acceptable?	Yes	No	
Is mat thickness appropriate for type mix (3:1 ratio minimum)?	Yes	No	
Is overlap on longitudinal joint adequate and straight?	Yes	No	
Rolling pattern: Are rollers going slow, mat temp. being considered?	Yes	No	
Paving equipment working properly? Any leaks?	Yes	No	
Compaction method? Core, nuclear, or non-nuclear?	Yes	No	
Is MTV being used on this Map?	Yes	No	
Does this map have Warm Mix? What technology?	Yes	No	
Packed and compacted before dropping below 185°?	Yes	No	

Plans for tomorrow (or next work day) to address any problems encountered today:

QA Roadway Technician Name and HICAMS No.

Signature

Note: It is suggested that the Contractor's representative initial or acknowledge items were reviewed together:

QA/QC-8 DAILY PAVING OPERATION EVALUATION FORM

GENERAL NOTE: This form to be used to evaluate general daily paving operations and assist with communications between Department and Contractor Roadway personnel in addressing any items that may need more attention or correction in the following days' paving operations.

1. Date mix was placed.
2. Contractor placing asphalt mix.
3. Mix Type being placed.
4. Project asphalt mix is being placed.
5. Individual paving operation items evaluated today.
6. Comment section to note any corrections involving above items. Should also be used to note any other changes not listed above to be performed to improve asphalt laydown operations.
7. Name of Departments Certified Roadway Technician and HiCAMS Number (printed).
8. Signature of Departments Certified Roadway Technician.