

Roane County is inviting sealed bids for the good(s) and/or service(s) listed below, subject to the terms and conditions of the Invitation to Bid (ITB), the accompanying specifications, and the Roane County Purchasing Manual.

At the appointed time bids will be publicly opened in the office of the Roane County Purchasing Agent at the above address. Bids arriving in the Purchasing Department past the appointed date and time will be considered late and will not be opened.

Deliver Bids To:

ROANE COUNTY PURCHASING DEPARTMENT
200 EAST RACE STREET, SUITE #3
KINGSTON, TENNESSEE 37763

**Bid Number: 2016-19/171
AMBULANCE**

Open Date & Time: April 7, 2016 at 2:00 p.m. (Eastern Time Zone)

The Bid Envelope must show the Bid Number, Name & Opening Date.

PURCHASING CONTACT INFORMATION

Lynn Farnham, CPPO, CPPB
Purchasing Agent
Phone: 865-376-4317
Fax: 865-376-4318
Email: lynn.farnham@roanecountytn.gov

GENERAL TERMS & CONDITIONS

1. Attached are instructions and conditions for submitting a bid for Roane County Government. The objective of this bid is to select suppliers in such a manner as to provide for open and free competition and comparability.

BID PREPARATION & SUBMISSION

1. Bidders are expected to examine any drawings, specifications, terms and conditions, general or special conditions, schedules and all instructions for the purpose of this bid. Failure to do so will be at the bidder's risk.
2. The total bottom line cost will be determined by multiplying each item bid price times the quantity requested and adding the extended dollar figures.
3. All bids shall be in accordance with the instructions to bidders and specifications included in this ITB. Specifications are intended to be open and non-restrictive.
4. All columns of the bid document must be completed in ink or typewritten. The bottom line total (sum of extended prices) must also be printed in ink or typewritten on the proposal form. No erasures shall be permitted. Errors may be crossed out and corrections printed in ink or typewritten and must be initialed in ink by the person signing the bid.
5. All bids must meet or exceed the enclosed specifications. Bidder must indicate the manufacturer's name and model number offered. If bidder fails to provide this information, and an award is made, then the bidder shall supply the item(s) as specified. All items supplied by the successful bidder shall be new and unused and meet all OSHA standards. Items delivered not meeting these requirements shall be subject to return and replaced at no additional cost to Roane County. Any exceptions to the specifications must be clearly noted, documented and have prior approval to be submitted as an approved alternate.
6. The use of the name of a manufacturer, brand, model or make used in describing an item does not restrict the bidder to that manufacturer. Others will be considered if they meet or exceed the items specified. When an alternate manufacturer, brand, model or make will be bid, five (5) days prior to the bid the bidder must submit documents to the Purchasing Agent, for evaluation of the product. Roane County will determine if the item does meet or exceed the item as specified.
7. It shall be the sole responsibility of the bidder to make certain that all bids in proper form are submitted to the Purchasing Department as described below.
8. Delivery charges are to be prepaid and included in the bid pricing.
9. All original forms must be signed by a person with authority to bind the bid. The bid must be sealed in an envelope that is labeled according to the directions stated below.
10. On the outside of the envelope/package mark the bid as follows:
 - Vendor Name & Address
 - Bid Number
 - Bid Date & Time
11. The bid must then be in a sealed envelope/package mailed or delivered to the following address:

Roane County Purchasing Department
200 East Race Street, Suite #3
Kingston, Tennessee 37763

Please note that Roane County does not receive a guaranteed delivery time for express mail and/or packages. Please mail accordingly.

12. Sealed written bids will be received at the time and place specified on the Invitation to Bid. Postmark on the Bid by this date will not suffice. Bid must be received on or before the date and time stated. Faxed bid documents will not be accepted.

LATE RECEIPT OF THE BID

1. The bid and modifications or withdrawals thereof received after the time set for opening will not be considered, unless they are received before the award is made and it is determined by Roane County that failure to arrive on time was due solely to a delay in delivery for which the bidder has no responsibility. Roane County does not receive a guaranteed delivery time for express mail and/or packages. Please mail accordingly.
2. Bids must be in the Purchasing Department prior to 2:00 p.m. on the appointed date. Time will be determined by the clock in the Roane County Purchasing Department and once Purchasing Agent/or their designee determines the time is 2:00 p.m., no other bids will be accepted.

BID PERIOD

1. Unless otherwise noted in the bid specifications, the contract will be awarded for the period of one (1) year from the date of bid opening. Roane County reserves the right to purchase additional items against this bid on an "as needed" basis if pricing remains the same. This does not apply to bids with options of renewal.

RESTRICTIVE OR AMBIGUOUS SPECIFICATIONS

1. It is the responsibility of the bidder to review the entire Invitation to Bid document and to notify the Purchasing Agent if the Invitation to Bid is formulated in a manner that would unnecessarily restrict competition or if it is ambiguous in what is being requested.
2. Pursuant to TCA §12-4-126, questions regarding the specifications or bid procedures must be received by the Purchasing Agent and/or designer no less than ninety-six (96) hours before the bid opening date. No addenda will be issued within less than forty-eight (48) hours of the bid opening day, excluding weekends and legal holidays designated in §15-1-101 unless the bid opening is extended for a reasonable time as determined by the purchasing agent, which shall not be less than forty-eight (48) hours excluding weekends and legal holidays designated in §15-1-101, to allow for any necessary changes to the Invitation to Bid documents and to allow responders to resubmit their responses accordingly.
3. Any questions concerning this Invitation to Bid are to be faxed to the Purchasing Department. Questions will be answered via addenda. Information obtained from any office other than the Purchasing Office is not to be considered binding.

BID OPENING & AWARD

1. Only the bottom line figure will be read at the bid opening. Bids will also be examined for compliance with specification and conditions outlined in the bid document.
2. Consideration will be given to all bids properly submitted. Bids will receive appropriate confidentiality before awarding. Upon award, bid documents and tabulations will be available for review. Errors discovered after public opening may not be corrected, and the bidder may be bound to honor bid as submitted. After investigation of the nature of the mistake, the Purchasing Agent may allow the bid to be withdrawn.
3. The contract will be awarded in writing to the most responsive bidder whose bid conforms best to the Invitation to Bid will be most advantageous to Roane County. It is the intent of Roane County to involve and utilize the best product/services at the best prices and provide small and minority firms, women's business enterprises and labor surplus area firms with increased opportunity to do business with the county. However, currently there are no set asides for small or minority firms.
4. Roane County reserves the right to accept or reject any or all bids and to waive informalities and minor irregularities in the bids received.

5. Roane County reserves the right to award the bid in its entirety or to divide the award in any way that will be more advantageous to the county.
6. Bid results will be posted on the County's website along with the bid tabulation.

PROTEST PROCEDURE

1. If a prospective vendor does not agree with the bid award, they have the right to protest. Disputes arising from the award of this bid must be submitted in writing to the Roane County Purchasing Department no later than seven (7) days from date of bid award. The steps for dispute resolution may include:
 - A meeting with the Purchasing Agent, the requisitioning department's manager and representatives from the disputing party to discuss and resolve the complaint.
 - Information from the aforementioned meeting will be forwarded to the County Attorney for review.
 - A written decision letter stating the reasons for the decision will be prepared by the Purchasing Agent and submitted in writing to the protestor and all parties involved.
 - Purchases will not be allowed under this procurement until a final decision is rendered.
 - In the event that purchases must be made before a final decision is rendered, the emergency purchase procedures will be used.

APPROPRIATION

1. In the event no funds are appropriated by Roane County for the goods or services in any fiscal year or insufficient funds exist to purchase the goods or services, then the contract shall expire upon the expenditure of previously appropriated funds or the end of the current fiscal year, whichever occurs first, with no further obligations owed to or by either party.

VENDOR QUALIFICATION

1. Potential bidders must meet the following criteria:
 - Be able to provide a quality product as specified
 - Offer reasonable pricing
 - Provide dependable delivery of items ordered
 - Meet specifications and bid conditions
 - Demonstrate successful past performance
2. A potential bidder may be rejected for one or more of the following reason:
 - Inadequate or unacceptable product lines
 - Bidding remanufactured or reconditioned items
 - Bidding alternate to approved item without notice prior to bid opening
 - Documented unacceptable product

INSURANCE

1. The contractor will maintain, at their expense adequate insurance coverage to protect them from claims arising under the Worker's Compensation Act, from claims for damages resulting from bodily injuries and damage to their property, for Bodily Injury and Property Damage Liability in the amount of no less than \$1,000,000, for Products and Completed Operations Liability of no less than \$1,000,000 and from claims for damage to any Roane County property. Additional insurance requirements may be listed any Special Terms & Conditions or in the Bid Specifications. This insurance company shall have a Best's rating of A or better. Any deviations from the above requirements must be disclosed in the bid submission.
2. The successful bidder shall furnish a Certificate of Insurance issued by their insurance company showing that Roane County as an additional insured. Carrier will assume full common liability of all shipments.

COMPLIANCE WITH ALL LAWS

1. Contractor is assumed to be familiar with and agrees to observe and comply with all federal, state, and local laws, statutes, ordinances, and regulations in any manner affecting the provision of goods and/or services, and all instructions and prohibitive orders issued regarding this work and shall obtain all necessary permits.

GOVERNING LAW

1. This contract shall be governed by the laws of the State of Tennessee, and all obligations of the parties are performable in Roane County, Tennessee. The Courts in Roane County shall have exclusive and concurrent jurisdiction of any disputes which arise hereunder.

BUSINESS LICENSES

1. Bidders located in Tennessee are required to have a current business license issued by the State of Tennessee at the time the bids are submitted. Vendors located outside Tennessee are required to obtain a business license issued by the State of Tennessee.
2. A Business Tax & License Affidavit is required to be submitted with the bid.

INDEMNIFICATION/HOLD HARMLESS

1. Contractor shall indemnify, defend, save and hold harmless all departments of Roane County Government and/or the Roane County Board of Education, its officers, agents and employees from all suits, claims, actions or damages of any nature brought because of, arising out of, or due to breach of the agreement by Contractor, its subcontractors, supplier, agents or employees or due to any negligent act or occurrence or any omission or commission of the contractor, its subcontractors, suppliers, agents or employees until the contract terminates.

VENDOR PERFORMANCE

1. If the contractor fails in full or part to perform or comply with any provision of this Contract or the terms or conditions of any documents referenced and made a part hereof, Roane County may terminate this contract, in whole or in part, and may consider such failure or noncompliance a Breach of Contract. Contractors with poor performance will be notified at the time of such performance and be given opportunity to correct the problems. Documentation will be kept on file. Any contractor with continued poor performance will be removed from the potential vendor list for one year.
2. Roane County expressly retains all its rights and remedies provided by law in case of such breach, and no action by Roane County shall constitute a waiver of any such rights or remedies. In the event of termination for default, Roane County reserves the right to purchase its requirements elsewhere, with or without competitive bid.
3. Failure to deliver within the time specified or within a reasonable amount of time, or failure to make replacements of a rejected item immediately will constitute authority to purchase on the open market so as to replace the item(s) rejected and/or not received. On all such purchases, the Vendor agrees to promptly reimburse the county for excess costs incurred by such a purchase.
4. Reasons for product rejection may be any one of the following:
 - Quality
 - Price
 - Serviceability of item (damage)
 - Product does not meet bid specifications

BREACH OF CONTRACT

1. A party shall be deemed to have breached the contract if any of the following occurs:
 - Failure to provide products or services that conform to contract requirements.
 - Failure to maintain/submit any report required hereunder.
 - Failure to perform in full or in part any of the other conditions of the contract.
 - Violation of any warranty.

CONTRACT TERMINATION FOR CAUSE

1. If the contractor fails to properly perform its obligations under this contract in a timely or proper manner, or if the contractor violates any terms of this contract, the county shall have the right to terminate the contract and withhold payments in excess of fair compensation for completed services.
2. In the event the contract is terminated for due cause by the county, the county shall have the option of awarding the contact to the next lowest bidder or bidding again.

CONTRACT TERMINATION FOR CONVENIENCE

1. The county may, by written notice to the contractor, terminate this contract without cause for any reason. Said termination shall not be deemed a Breach of Contract by the county. The county must give notice of termination to the vendor at least thirty (30) days prior to the effective date of termination. The contractor shall be entitled to receive compensation for satisfactory, authorized service completed as of the termination date, but in no event shall the county be liable to the contractor for compensation for any service which has not been rendered. Upon such termination, the vendor shall have no right to any actual general, special, incidental, consequential, or any other damages whatsoever of any description or amount.

BOOKS AND RECORDS

1. The contractor shall maintain all books, documents, accounting records and other evidence pertaining to the goods and services provided under this contract and make such materials available at its offices at all reasonable times during the contract period and for three (3) years from the date of the final payment under this agreement for inspection by county or by any other governmental entity or agency participating in the funding of this agreement, or any authorized agents thereof; copies of said records to be furnished if requested. Such records shall include those books, documents and accounting records that represent the vendor's costs of manufacturing, acquiring or delivering the products and services governed by this agreement.

DELIVERY

1. All items included in this Invitation to Bid is to be delivered with no evidence of damage. The successful bidder agrees to be responsible for damaged packaging and to replace any damaged components or equipment at no charge.
2. Roane County shall retain the right to reject any or all of a delivery that does not meet product specifications. Rejected items are to be picked up at the supplier's expense.

INSPECTION AND ACCEPTANCE

1. Warranty periods shall not commence until Roane County inspects and formally accepts the goods and/or services. The terms, conditions and timing of acceptance shall be determined by Roane County. Roane County reserves the right to reject any or all items or services not in conformance with applicable specifications, and contractor assumes the costs associated with such nonconformance. Acceptance of goods or services does not constitute a waiver of latent or hidden defects or defects not readily detectable by a reasonable person under the circumstances.

INVOICES AND PAYMENTS

1. Payment will be made within 30 days after receipt of invoice and/or delivery of items included in this Invitation to Bid, whichever is later.
2. Roane County Government is not subject to taxation. A tax exemption certificate will be provided upon request.

NONDISCRIMINATION AND NON-CONFLICT STATEMENT

1. Contractor agrees that no person on the grounds of handicap, age, race, color, religion, sex or national origin, shall be excluded from participation in, or be denied benefits of, or be otherwise subjected to discrimination in the performance of this agreement, or in the employment practices of vendor. Contractor shall upon request show proof of such nondiscrimination, and shall post in conspicuous places available to all employees and applicants notices of non-discrimination. Contractor covenants that it complies with the Fair Wage and Hour Laws, the National Labor Relations Act, and other federal and state employment laws as applicable. Contractor covenants that it does not engage in any illegal employment practices.
2. Contractor covenants that it has no public or private interest, and shall not acquire directly or indirectly any interest; that would conflict in any manner with the provision of its goods or performance of its services. The contractor warrants that no part of the total contract amount provided herein shall be paid directly or indirectly to any officer or employee of Roane County as wages, compensation, or gifts in exchange for acting as officer, agent, employee, subcontractor or consultant to contractor in connection with any goods provided or work contemplated or performed relative to the agreement.
3. No employee or member of the Roane County's governing bodies shall participate in the selection or award of a contract if a conflict of interest, real or apparent, would be involved.
4. Officers, employees or officials of the Roane County Government shall neither solicit nor accept gratuities, favors or anything of more than nominal monetary value from vendors or parties to subcontracts.

Bid Number: 2016-19/171 – AMBULANCE
VENDOR INFORMATION SHEET
(Please fill out completely)

By completing and signing this form you certify that you are an authorized representative of the company for which you are submitting a bid/proposal and that you have the authority to legally bind your company. Further, by completing and signing this form you certify that you agree to all the terms and conditions of this bid/proposal.

1. Vendor Name _____

2. Address _____

City _____ State _____ Zip Code _____

3. Contact Person (Please Print) _____

4. Telephone Number _____ Fax Number _____

5. Vendor's e-mail address _____

6. Authorizing Signature _____

7. Title of Person Signing Bid _____

8. If addenda were issued, please acknowledge the receipt of: (please write "yes" if you received one)
Addendum 1 _____ Addendum 2 _____ Addendum 3 _____ Addendum 4 _____

9. If applicable, please indicate below if discounts will be allowed for prompt payment or if there is not discount offered:
_____ % Net 10 Days; _____ % Net 20 Days; _____ % Net 30 Days; _____ No Discount

COOPERATIVE PURCHASING - Vendors are to indicate if it is permissible for other governmental agencies in the State of Tennessee to purchase these items or services at the same price. Freight charges may be adjusted to reflect differences in delivery costs to other locations. Please indicate the approval of Cooperative Purchasing.

_____ Yes _____ No

SCHOOL CONTRACTS ONLY

CRIMINAL HISTORY RECORDS CHECK – Do you agree to comply with Public Chapter 587 of 2007 which requires all contractors to facilitate a criminal history check, including fingerprinting, conducted by the Tennessee Bureau of Investigation and the Federal Bureau of Investigation for each employee or subcontractor personnel before permitting the employee or subcontractor personnel to have contact with students or enter school grounds?

_____ Yes _____ No

**Bid Number: 2016-19/171 – AMBULANCE
NON –COLLUSION, INDEPENDENT PRICE DETERMINATION,
NON-DISCRIMINATION, NON-DEBARMENT & LOBBYING AFFIDAVIT**

I do hereby certify that this bid is made without prior understanding, agreement, or connection with any corporation, firm, or person submitting a bid for the same materials, supplies, or equipment, and is in all respects fair and without collusion or fraud.

I understand that collusive pricing is a violation of State and Federal law and can result in fines, prison sentences, and civil damage awards and that no collusion with another firm was used in preparation of this bid.

I also certify that this firm does not discriminate against any employee or applicant for employment on the grounds of race, color, national origin or sex; and does not and will not maintain or provide for his employees any segregated facilities at any of its establishments, and further, that the firm does not and will not permit their employees to perform their services at any location under this contract where segregated facilities are maintained.

By submission of this bid, the bidder certifies that neither it or its principals is presently debarred, suspended, proposed for debarment, declared ineligible or voluntarily excluded from participation in this transaction by any Federal or State department or agency.

I further certify that during the Invitation to Bid solicitation and/or during the performance of this contract that neither it nor its principals will participate in lobbying activities in conjunction with this project.

I agree to abide by all terms and conditions of this Invitation to Bid and certify that I am authorized to sign this affidavit for the vendor.

Please indicate which of the following apply to your company. This information is requested for information purposes only. Roane County currently has no policy that allows for set asides or preferences for woman owned or minority owned businesses.

African American Owned
 Caucasian Owned
 Native American Owned
 Other Owned

Asian Owned
 Hispanic Owned
 Woman Owned

Signature

Title

**Bid Number: 2016-19/171 – AMBULANCE
BUSINESS TAX & LICENSE AFFIDAVIT**

Please sign the affidavit below stating that your company does have a Business License and that your Business Taxes are current. Companies located outside the State of Tennessee are required to have a Business License in Tennessee.

The undersigned states that he/she has legal authority to swear this on behalf of _____ (Vendor); and that Vendor is not in any manner in violation of *Tennessee Code Annotated, §5-14-108(l)* which provides that “no purchase shall be made or purchase order or contract of purchase issued for tangible personal property or services by county officials or employees, acting in their official capacity, from any firm or individual whose business tax or license is delinquent”.

Affiant affirms and warrants that Contractor’s licenses are currently valid and all business taxes have been paid and are current as of the date of this affidavit. Contractor is licensed and pays business taxes in _____ County, Tennessee.

VENDOR

By: _____

Title: _____

Date: _____

Witness: _____

Date: _____

**Bid Number: 2016-19/171 – AMBULANCE
PRICE SHEET**

Base Bid

Please provide the information requested below:

Make/Model/Year of Chassis	
Warranty on Chassis	
Warranty on Workmanship	
Delivery After Receipt of Order	
Price for Ambulance as Specified	

**Bid Number: 2016-19/171 – AMBULANCE
BID SPECIFICATIONS**

Roane County is inviting bids for one (1) new Type III Ford E-350 Gas 146" x 90" Module as per the enclosed bid specifications.

The bid specifications were provided by Medix Specialty Vehicles and is not intended to exclude any manufacturer from bidding. Any ambulance that meets or exceeds these specifications will be considered.

Table of Contents

1.0	SCOPE & GENERAL REQUIREMENTS
2.0	CHASSIS
3.0	MODULE CONFIGURATION
4.0	MODULE CONSTRUCTION – GENERAL
5.0	FLOOR CONSTRUCTION
6.0	SIDE STRUCTURE
7.0	ROOF CONSTRUCTION
8.0	DOOR CONSTRUCTION
9.0	COMPARTMENT CONSTRUCTION & CONFIGURATION
10.0	CORROSION: Anti-electrolysis procedures
11.0	REAR BUMPER
12.0	BODY PROTECTION
13.0	CABINTRY
14.0	CABINET CONFIGURATION
15.0	UPHOLSTERY
16.0	INTERIOR HARDWARE
17.0	OXYGEN, VACUUM SYSTEMS
18.0	ELECTRICAL SYSTEM - 12-Volt Direct Current
19.0	ELECTRICAL SYSTEM - 125-Volt Alternating Current
20.0	ENVIRONMENTAL
21.0	CONSOLES, SWITCH PANELS
22.0	VISUAL CONSPICUITY - EXTERIOR LIGHTING
23.0	AUDIBLE CONSPICUITY
24.0	INTERIOR LIGHTING
25.0	COMMUNICATIONS EQUIPMENT
26.0	PAINT, LETTERING, DECALS, MISCELLANEOUS
27.0	REFERENCES AND STANDARDS
APPENDIX	STANDARD MODEL DRAWINGS

Ambulance Bid Specifications

EMERGENCY MEDICAL VEHICLE – Type III Ford E-350 Gas 146” x 90”

SCOPE & GENERAL REQUIREMENTS

This specification describes a commercial cutaway chassis with a transferable modular body converted into a Type III, 4X2 ambulance configuration as defined in the FEDERAL SPECIFICATION FOR STAR-OF-LIFE AMBULANCE, KKK-A-1822F, dated August 1, 2007. Unless otherwise specified, this vehicle shall be manufactured in accordance with the ambulance design criteria of the National Highway Traffic Administration, U.S. Department of Transportation in Washington D.C and the GSA - Federal Ambulance Specification KKK-A-1822F. Documentation shall be submitted with the bid that validates the manufacturer's current and full compliance with KKK-A-1822F or submits proof of the manufacturer's intent to have this testing completed prior to delivery of the proposed new ambulance. The ambulance described herein shall be type and model tested to and in compliance with the National Truck Equipment Association's Ambulance Manufacturing Division, Standards 001 - 025. Certifications must be current to manufacturer's most recent manufacturing/engineering design criteria.

The standard for the configuration and design of this ambulance exceeds the current KKK Federal Specification due to the requirements of this department. Manufacturers, who are unwilling or unable to meet the requirements herein, will not be considered.

The purpose of these specifications is to provide a set of minimum general requirements and test parameters for the manufacture of an emergency medical care ambulance that meets the needs and desires of this agency. The bidder is responsible for understanding that this specification establishes the essential criteria for design, performance, equipment and appearance of the ambulance or rescue vehicle. This specification requires an all-aluminum modular exterior. The compartment and cabinet sizes are critical and changes will not be allowed. While it is not the intent of this specification to preclude any qualified bidder, it must be clear that any bidder deviating in any substantial manner from these specifications will be rejected as non-compliant.

Does Your Bid Comply? Yes No Exceptions _____

This specification requires the manufacturer to provide a new, commercially produced, medical care vehicle, hereinafter referred to as an "ambulance" or "rescue vehicle". This vehicle shall be manufactured in accordance with the ambulance design criteria of the National Highway Traffic Administration, U.S. Department of Transportation in Washington D.C and the GSA - Federal Ambulance Specification KKK-A-1822F. Documentation shall be submitted with the bid that validates the manufacturer's current and full compliance with KKK-A-1822E. NO Exceptions

1.0 MANUFACTURE

1.1 Shall be a modified vehicle Upfitter approved by the OEM chassis manufacturer whose chassis is used to complete this Specified vehicle. Additionally, the manufacturer shall hold current certification in the Ford Motor Company Qualified Vehicle Modifier Program, and shall submit a copy of the QVM certificate as part of the bid proposal. This certification insures the integrity of the “conversion” of a vehicle into an ambulance regardless of chassis make.

1.2 Shall submit a copy of current certification of compliance with Federal Specification KKK-A-1822F for the type vehicle described herein, as prepared by an ISO/IEC 17025:2005 certified, independent, third-party testing laboratory.

1.3 Shall carry not less than ten million dollars (\$10,000,000.00) in product liability insurance.

1.4 Shall employ full-time Parts personnel.

1.5 Shall employ a full-time Electrical Troubleshooter.

1.6 Shall employ a full-time Service/Warranty Representative.

1.7 Shall furnish custom Computer Aided Design (CAD) interior and exterior construction drawings specific to the vehicle to be produced under this Specification. Drawing dimensions must comply with AMD Standard 019- Measuring Guidelines: Cabinets and Compartments

1.8 Shall furnish custom CAD electrical illustrations (including physical layouts of switch panels and electrical component mounts) and electrical schematics specific to the vehicle to be produced under this Specification.

1.9 Shall furnish proof of manufacturing complete ambulance packages for a minimum of 15 years.

Does Your Bid Comply? Yes No Exceptions _____

The ambulance and the allied equipment required by this specification shall be the manufacturer's current commercial ambulance model of the type and class specified. The ambulance shall be complete with the required options and accessories as specified herein. Items will be furnished with such modifications as may be necessary and specified to enable the ambulance to function reliably and efficiently in a strenuous, sustained operation. The design of the vehicle and the specified options shall permit accessibility for servicing, replacement and adjustment of components and accessories with minimum disturbance to other components and systems. The term "heavy-duty" as used, shall describe equipment or items that are in excess of the usual quality or capacity that is normally supplied with standard production vehicles or components.

This department requires that the manufacturer of the ambulance be a 100% American owned company. American owned defines the manufacturer as well as the majority equity owners of the manufacturer as US companies, individuals and/or stockholders.

The ambulance and the allied equipment required by this specification shall be the manufacturer's current commercial ambulance model of the type and class specified.

Does Your Bid Comply? Yes No Exceptions _____

The bidder shall be obligated to provide an estimated delivery time from award of bid and a selection of flooring, upholstery and Scotchlite colors for the customer to make the appropriate selections. These color selections shall become a part of the customers order and the bidders manufacturing document.

Does Your Bid Comply? Yes No Exceptions _____

This is an engineer, design, construct and delivery type specification and it is not the intention of this agency to write out vendors or manufacturers of similar or equal equipment of the types specified. It should be noted, however, that this specification is written around specific needs of this agency. With the intent to standardize certain components, therefore, in numerous places we have named specific brands of components. This has been done to establish a certain standard of quality. Other brands will be accepted providing the vendor provides documentation in the bid that the particular brand offered meets or exceeds the quality of the actual brand called for in the specification.

Does Your Bid Comply? Yes ____ No ____ Exceptions _____

Bidder must furnish all information as requested. Additionally the bidder shall supply descriptive literature and complete specifications covering the products offered. Bids not meeting this requirement will be rejected. No Exceptions.

Does Your Bid Comply? Yes ____ No ____ Exceptions _____

All bid prices shall be complete and include warranty and delivery of the completed vehicle to the purchaser. Payment shall be made in accordance with the terms, and conditions of these specifications. Payment will be made upon delivery and acceptance of the vehicle(s) and equipment specified herein.

All bid prices and conditions must be specified on the Bid Proposal Form. Bid prices shall be valid for 30 days from the date of the bid opening, or as otherwise specified in the bid proposal. Payment in full will be made as each unit is received, inspected and found to comply with these specifications. The vehicles(s) shall be free of damage and properly invoiced.

Does Your Bid Comply? Yes ____ No ____ Exceptions _____

By submission of this signed bid response, the bidder certifies under penalty of perjury, that to the best of his/her knowledge that the pricing in this bid response has been prepared independently without collusion, consultation, communication, or agreement for the purpose of restricting competition, as to any matter relating to such pricing with any other bidder or competitor. The bidder also acknowledges that the pricing quoted has not been discussed with or disclosed by the bidder prior to the opening of the bid, either directly or indirectly.

Does Your Bid Comply? Yes ____ No ____ Exceptions _____

The bidder's proposal packet shall include a copy of the ambulance manufacturer's current insurance certificate. The manufacturer shall provide proof of \$10 Million dollars of product liability insurance coverage. No Exception.

Does Your Bid Comply? Yes ____ No ____ Exceptions _____

The bidder's proposal packet shall include copies of all warranties listed in these following detailed specifications. The minimum acceptable required warranties are: Conversion Warranty, Electrical Warranty, Modular Structural Warranty and Paint Warranty. The bidder shall include a copy of these warranties within the proposal package. If the bidder does not include a copy of the warranties, the bid will automatically be rejected.

Does Your Bid Comply? Yes ____ No ____ Exceptions _____

2.0 CHASSIS

2.1 TYPE III AMBULANCE: The apparatus shall be a Type III, Class 1, 2-door, Ford E-350 Cutaway van with a transferable, modular ambulance body.

Does Your Bid Comply? Yes No Exceptions _____

2.2 AMBULANCE PREPARATON PACKAGE: The chassis provided shall be equipped with an ambulance preparation package designed and installed by the O.E.M. The package shall be designed to meet the demands and duty cycles inherent in Emergency Medical Vehicles.

Does Your Bid Comply? Yes No Exceptions _____

2.3 THROTTLE – HIGH IDLE: An O.E.M. throttle control shall be provided. The throttle shall be programmed for charge protect. The throttle control module shall be located in the console base.

Does Your Bid Comply? Yes No Exceptions _____

2.4 GROSS VEHICLE WEIGHT RATING (GVWR): The GVWR of the chassis supplied shall be at least 11,500 pounds.

Does Your Bid Comply? Yes No Exceptions _____

2.5 FRONT AXLE WEIGHT RATING (GAWR-F): The GAWR-F shall be rated at no less than 5,000 pounds.

Does Your Bid Comply? Yes No Exceptions _____

2.6 REAR AXLE WEIGHT RATING (GAWR-R): The GAWR-R shall be rated at no less than 8,500 pounds.

Does Your Bid Comply? Yes No Exceptions _____

2.7 REAR AXLE TYPE AND RATIO: The axle type shall be limited slip differential with a 4.10:1 gear ratio.

Does Your Bid Comply? Yes No Exceptions _____

2.8 ENGINE: A V-10, Gasoline engine with 305HP @ 4,250RPM / 420 lb.-ft. torque at 3,250RPM and a minimum displacement of 6.8 liters (414 cu in) shall be provided. The engine performance shall comply with or exceed KKK-A-1822F and AMD Standards 005- 12-Volt DC Electrical System Test, 014- Engine Cooling System Test, 017- Road Test and 022- Cold Engine Start Test.

Does Your Bid Comply? Yes No Exceptions _____

2.9 TRANSMISSION: A 6-speed, electronic automatic transmission with overdrive shall be provided.

Does Your Bid Comply? Yes No Exceptions _____

2.10 BATTERIES: Two batteries shall be mounted to provide easy access for servicing. The batteries shall be at least 650 CCA each.

Does Your Bid Comply? Yes _____ No _____ Exceptions _____

2.11 BRAKES: 4-wheel anti-lock, power assisted hydraulic brakes shall be supplied by the O.E.M. The brakes shall be 4-wheel Disc type. The parking brake shall be an independent mechanical brake, provided by the O.E.M.

Does Your Bid Comply? Yes _____ No _____ Exceptions _____

2.12 TIRES: All tires shall be identical make, tread type, size and load range. For aforementioned GVWR the tires shall be LT225/75R16E. A label with the recommended tire pressure shall be located above each wheel opening, unless specified otherwise by the purchaser. All tires shall be balanced per KKK-A-1822F 3.6.10.

2.13 STAINLESS STEEL WHEEL INSERTS: Stainless Steel Wheel Inserts shall be installed. Both rear wheels shall have braided valve extenders installed. Wheel inserts shall not be attached to the wheels utilizing the OEM lug nuts.

Does Your Bid Comply? Yes _____ No _____ Exceptions _____

2.14 MUD FLAPS: Heavy duty rubber Mud Flaps shall be provided behind the rear dual wheels.

Does Your Bid Comply? Yes _____ No _____ Exceptions _____

2.15 SPARE TIRE: One (1) spare tire and wheel assembly shall be supplied. When the tire is to be carried on the unit, the tire hold down and O.E.M. jack and tire tools shall be provided with the spare.

Does Your Bid Comply? Yes _____ No _____ Exceptions _____

2.16 OCCUPANT RESTRAINT SYSTEM: The front, forward facing cab seats shall be equipped with O.E.M. installed Type II lap and shoulder belt assemblies.

The seat belts shall have pre-tensioners built into the seatbelt assembly to take up belt slack during a frontal collision. The seat belt assemblies shall meet or exceed F.M.V.S.S. 208 and 209. Any transition trim panels installed in the cab shall not interfere with the swivel arc of the shoulder rings.

Does Your Bid Comply? Yes _____ No _____ Exceptions _____

2.17 SUPPLEMENTAL RESTRAINT SYSTEM: An O.E.M. air bag shall be installed on the driver and passenger side. Permanent or quick release ambulance conversion components shall not interfere with air bag deployment. The air bags must be completely operational. Modifications by the secondary manufacturer are not acceptable.

Does Your Bid Comply? Yes _____ No _____ Exceptions _____

2.18 FUEL TANK: The fuel capacity shall be at least 40 U.S. gallons. The fuel range shall be at least 250 miles per KKK-A-1822F 3.4.8.

Does Your Bid Comply? Yes ____ No ____ Exceptions _____

2.19 CAB SEATS: O.E.M. High back, stain-resistant cloth covered bucket type seats shall be provided in the cab. The seats shall adjust forward and aft. Seat base must be O.E.M. After-market seats and/or bases are not acceptable due to certified requirements regarding S.R.S. (Air bag) deployment geometry. The seats shall have external moisture repellent in case of contact with blood or body fluids.

2.20 CAB STEREO: An O.E.M. AM/FM/CD in dash radio shall be included with the chassis.

Does Your Bid Comply? Yes ____ No ____ Exceptions _____

2.21 MIRRORS: Dual electrically controlled extending mirrors with built in convex mirror shall be provided.

Does Your Bid Comply? Yes ____ No ____ Exceptions _____

2.22 DOOR LOCKS: The cab doors shall have O.E.M. power door locks. A momentary rocker type switch shall active (Lock/Unlock) both cab doors.

Does Your Bid Comply? Yes ____ No ____ Exceptions _____

2.23 TRIM PACKAGE: The highest level trim package shall be supplied from the O.E.M. The package shall include high quality chrome-like bright work on the grille face. Chrome plated steel bumper(s) shall also be supplied by the O.E.M. Argent or painted bumpers are not acceptable. The O.E.M. grille work shall remain O.E.M.

Does Your Bid Comply? Yes ____ No ____ Exceptions _____

2.24 RUNNING BOARDS: Running boards shall be constructed of .125 aluminum diamond plate and provide "splash guard" components to protect the running board surfaces from front wheel wash.

Does Your Bid Comply? Yes ____ No ____ Exceptions _____

2.25 UNDERCOATING: Chassis and module shall be fully undercoated in accordance with the chassis manufacturer's guidelines.

Does Your Bid Comply? Yes ____ No ____ Exceptions _____

2.26 WINDSHIELD SUN VISORS: OEM, stain resistant cloth covered sun visors shall be installed over the driver's and passenger's sides of the windshield.

Does Your Bid Comply? Yes ____ No ____ Exceptions _____

3.0 MODULE CONFIGURATION

3.1 OVER ALL LENGTH: The overall length of the vehicle shall not exceed two hundred forty nine inches (249"). The finished vehicle shall meet or exceed KKK-A-1822F 3.4.10.4 for Angle of Departure, Ramp Break Over and Angle of Approach.

Does Your Bid Comply? Yes ____ No ____ Exceptions _____

3.2 MODULE LENGTH: The module length shall be at least one hundred forty-six (146") inches.

Does Your Bid Comply? Yes ____ No ____ Exceptions _____

3.3 MODULE WIDTH: The module width shall comply with State requirements regarding width of vehicles permitted on its roads and highways. The module shall be ninety (90") inches wide, excluding lights and accessories. The rear wheels of the chassis shall not extend further than 2.5" from the vertical sidewall and be covered by fender flares as cited in Item 10.5 of this Specification.

Does Your Bid Comply? Yes ____ No ____ Exceptions _____

3.4 PATIENT COMPARTMENT HEADROOM: The headroom within the module shall be sixty-eight (68") inches. The measurement shall be taken from the center of the patient compartment floor to the ceiling panel.

Does Your Bid Comply? Yes ____ No ____ Exceptions _____

3.5 BULKHEAD CONFIGURATION: The bulkhead shall be a solid wall broken only by an 18"W x 46"H walk-thru opening. There shall be a sliding door with a fixed Lexan window of at least 150 square inches of viewing area. The window shall be transparent and shatterproof. The sliding door shall lock in place in both the open and closed positions.

Does Your Bid Comply? Yes ____ No ____ Exceptions _____

3.6 COMPARTMENT CONFIGURATION: The minimum compartment dimensions shall be as described within this specification and as depicted in the CAD drawings attached to the specification.

Does Your Bid Comply? Yes ____ No ____ Exceptions _____

3.7 SPARE TIRE STORAGE: Unless otherwise specified, a full size, fully inflated spare tire matching the wheels and tires mounted on the chassis shall be shipped loose. An O.E.M. jack and tire tools shall also be provided and shipped loose.

Does Your Bid Comply? Yes ____ No ____ Exceptions _____

4.0 MODULE CONSTRUCTION - GENERAL

The ambulance body shall be all aluminum. The body structure shall be manufactured by the OEM ambulance manufacturer, not an outside vendor. This Agency will not accept bids from ambulance manufacturers that sub-contract the manufacture the ambulance body being bid.

Does Your Bid Comply? Yes _____ No _____ Exceptions _____

4.1 BODY STRUCTURE ALLOY: The side, roof, front and rear sheets shall be derived from .090 thick 5052-H-32 Aluminum sheet. The roof sheet shall be one piece, from roof rail to roof rail. The side, roof and floor structure and structural shapes shall be 6005-T5 extruded aluminum.

All frame and structural members shall be MIG (metal inert gas shielded) welded together to form a "roll cage" type structure. No rivets, screws, adhesive or other mechanical fasteners shall be used for the attachment of any structural or frame member used to form this critical structure.

Does Your Bid Comply? Yes _____ No _____ Exceptions _____

4.2 BODY WARRANTY: The body shall carry a 15-year warranty following the date of delivery to the end user. The warranty shall cover repairs or replacement of body elements or components that fail due to structural defects in materials and workmanship. "Life Time Warranties" shall not be acceptable, unless the protection coverage is CLEARLY specified and attached in its entirety, with the bid. Hollow, no content and/or unclear "Life Time Warranties" are not acceptable.

Does Your Bid Comply? Yes _____ No _____ Exceptions _____

4.3 STRUCTURAL INTEGRITY: The body shall be capable of providing impact, deformation and penetration resistance in the event of a collision. The body structure shall be capable of passing a stand-alone static load test on a type-tested body. The test shall be conducted in accordance to AMD Standard 001. The test weight shall be applied at no less than 2.5 times the curb-weight of the finished vehicle to both the top and either the streetside or curbside of the ambulance module.

Does Your Bid Comply? Yes _____ No _____ Exceptions _____

4.4 BODY PANEL MANUFACTURE: Each body panel, front wall, rear wall, two side walls, and roof panel, shall be manufactured utilizing .090" aluminum sheet, 2"x2"x.125" and 1"x2"x.125" extruded aluminum framework with voids between the tubular structure filled with 2" thick block polystyrene and covered with .125" laminated Luan. These panel components shall be integrated utilizing high strength adhesives. The aluminum sheet shall be attached to the wall structure with a Methacrylate adhesive with at shear and tensile strength of approximately 2,215 psi and a tensile modulus of 157,090 psi. The block foam and ply shall be attached with a urethane adhesive with a minimum tensile strength of 300 psi. The entire assembly shall be vacuum cured to form a solid, penetration resistant composite body panel. In no case shall screws, rivets, VHB tape or any other mechanical fasteners be used to attach the skin to these structural members.

The two body side panels shall overlap the front and rear wall by $\frac{3}{4}$ " and the four vertical corners shall be full-seam welded top to bottom on the outside and interval/stitch-welded every 5" along the inside. The roof panel shall overlap the front rear and side walls by $\frac{3}{4}$ " and all four sides along the exterior roofline shall be full-seam, full perimeter welded roof panel to walls and interval/stitch-welded every 5" inside.

Does Your Bid Comply? Yes ____ No ____ Exceptions _____

4.5 MODULE INSULATION: The insulation material shall be 2" thick, 1-lb. density polystyrene block insulation. The insulation shall be permanently bonded to the exterior skin and interior wall liner and provide full perimeter, void less insulation front wall, side walls and roof.

Does Your Bid Comply? Yes ____ No ____ Exceptions _____

4.6 REMOUNTABLE: The body shall be designed to be remounted to like chassis with same cab-to-axle dimensions.

Does Your Bid Comply? Yes ____ No ____ Exceptions _____

4.7 WELD QUALITY: All welds within the modular body shall meet American Welding Society codes for structural and sheet welding. All weld sites shall be cleaned prior to welding. All welds shall be free of cracks, cavitations, oxidation and foreign substances. All MIG welds shall be shielded with Argon, during the process.

Does Your Bid Comply? Yes ____ No ____ Exceptions _____

5.0 FLOOR CONSTRUCTION

5.1 FLOOR MEMBERS: The floor shall be at the lowest level permitted by clearances and shall meet the floor height requirements of KKK-A-1822F, 3.4.10.6. The lateral and longitudinal floor structure shall consist of 2" x 2" x .125" and 1" x 2" x .125" - 6005-T5 structural aluminum tubing. The finished assembly shall be securely welded to the wall structures and exterior compartments. There shall be .50" aluminum plates welded into the floor structure to facilitate mounting of the Technician's seat base and cot retention hardware. The floor weight bearing capability shall be compliant with AMD Standard 020- Floor Distributed Load Test, S4.3 Bariatric Load.

Does Your Bid Comply? Yes ____ No ____ Exceptions _____

5.2 MOISTURE BARRIER: Over the floor substructure there shall be applied a moisture barrier of .060 inch thick aluminum skin. This skin shall be attached to the floor structure by a full bed application of a high performance elastomeric adhesive/sealant. This adhesive bed shall be adequate to eliminate any material vibration and to completely seal the patient compartment from fumes and moisture penetrating the interior.

Does Your Bid Comply? Yes ____ No ____ Exceptions _____

5.3 CARBON MONOXIDE PROTECTION: To prevent carbon monoxide penetration into the patient compartment, it is imperative that the entire underside of the modular body be sealed. All hollow corner structural materials shall be sealed with either expansion moisture resistant, closed cell foam or sealed metal plates. This completed vehicle shall be compliant with AMD Standard 007- Patient Compartment Carbon Monoxide Test.

Does Your Bid Comply? Yes ____ No ____ Exceptions _____

6.0 SIDE STRUCTURE

SHEET: The skin covering the front, sides, and rear walls shall be a single aluminum sheet with an alloy and temper strength of 5052 H32 for strength, ease of welding, and corrosion resistance. Modular bodies fabricated from "multi-piece" front, rear or side skins are not acceptable to this agency.

These panel components shall be integrated utilizing high strength adhesives. The aluminum sheet shall be attached to the wall structure with a Methacrylate adhesive with at shear and tensile strength of approximately 2,215 psi and a tensile modulus of 157,090 psi. The block foam and ply shall be attached with a urethane adhesive with a minimum tensile strength of 300 psi. The entire assembly shall be vacuum cured to form a solid, penetration resistant composite body panel. In no case shall screws, rivets, VHB tape or any other mechanical fasteners be used to attach the skin to these structural members.

Does Your Bid Comply? Yes No Exceptions _____

6.1 SIDE STRUCTURAL MEMBERS: The side assembly shall be reinforced vertically with square aluminum extruded structural on an average of twelve (12) inch centers. These structural members shall be 2"x2" extruded box tubing with an equivalent wall thickness of .125 inch. To minimize the possibility of the extrusion bending, twisting or suffering other deformation when stressed, the extrusion shall be designed that each boxed formed corner extrusion on the sides, front, rear, and roof overlap the opposing extrusion, thus allowing for full length vertical welds on the entire outside of the body and the inside of the body. There shall be 4" x .50" aluminum plates welded into the curbside wall structure to facilitate the mounting of the seat belt assemblies. These structures shall be MIG welded together to form the body's roll cage and corner impact protection

Does Your Bid Comply? Yes No Exceptions _____

6.2 CORNER SIDEWALL ASSEMBLY: The four full-welded vertical corner seams and four full-welded horizontal roof seams shall be covered with .125" extruded aluminum, radius corner extrusion bonded with Lord's 406-17 acrylic adhesive with a tensile strength of 4,650 psi and an elastic modulus of 130,000 psi creating an integrated corner support column. The cast aluminum corner caps shall be seam-welded in place. All exterior body holes for lighting or other appliances shall be routed, drilled or punched prior to prime and paint process to assure complete coverage of raw metal on edges of holes.

Does Your Bid Comply? Yes No Exceptions _____

7.0 ROOF CONSTRUCTION

7.1 PERIMETER EXTRUSIONS: The roof's substructure assembly shall consist of perimeter extrusions, lateral roof bows, and interconnecting corner caps.

Does Your Bid Comply? Yes No Exceptions _____

7.2 ROOF SHEET: The roof skin shall have an alloy and temper strength of 5052 H32. The skin shall be attached to the lateral roof bows with a combination high strength urethane and Methacrylate adhesives applied prior to a vacuum bonding process to provide even and consistent adhesion of the wall skin to the structural extrusions. In no case may screws, rivets or other mechanical fasteners be used to attach the skin to the lateral roof bows.

Does Your Bid Comply? Yes No Exceptions _____

7.3 ROOF BOWS: The lateral roof bows shall be 2" x 2" x .125" primary and 1" x 2" x .125" secondary extruded aluminum tubing. These structures shall be MIG welded together to form the body's "roll cage". These structural members shall be located so that the roof skin is supported on a minimum "center" distance of 14 inches. The roof bows shall interconnect with the roof side rails and be continuously welded at all contact points. In no case shall a lateral roof bow have free span of more than 42 inches. There shall be eight (8) .125" aluminum plates welded into the roof structure to facilitate mounting of the patient compartment dome lights. There shall also be .250" aluminum plates welded into the roof structure to facilitate mounting of the overhead grab rail and a cargo net at the head of the squad bench. There shall be 1" x 2" x .125" tubing welded into the roof structure to provide secure mounting support for four CPI model 2008 folding IV hangers and for mounting potential recessed fluorescent fixtures.

Does Your Bid Comply? Yes No Exceptions _____

7.4 ROOF CORNERS: The roof rail extrusions shall be welded together along the roof bow mating walls at the corners. In addition, the outer surfaces of the roof rail extrusions shall be continuously MIG welded to cast aluminum corner castings. The castings shall have integral flanges behind the weld sites to interlock the joint.

Does Your Bid Comply? Yes No Exceptions _____

8.0 DOOR CONSTRUCTION

8.1 DOOR SKIN: The door skin shall be .090 thick 5052-H32 aluminum sheet CNC cut and formed to create a robust, crevice free environment to mirror the mating surface of the door jamb extrusions and to provide optimum paint adhesion and corrosion resistance. The formed edges shall not have elongation cracks due to forming but shall have edges uniformly rounded for strength and aesthetic appeal. The forming process will produce a door with an integral surface for mounting a pliable air core rubberized neoprene gasket around the full perimeter of the door that will seat and seal against the mating surface on the door jamb. The CNC process will provide the cut-out for windows, latches, door panel mounting holes and hinge mounting points all machined into the finished raw door. The CNC cut, fold and weld process provides a guaranteed consistent tolerance within 1/5,000th of an inch which yields a finished product that is consistently repeatable and easily replaceable in the event of damage.

Does Your Bid Comply? Yes No Exceptions _____

8.2 DOOR PANELS: The inside door panels shall be made of .090" aluminum sheet laminated to match the interior of the unit. There shall be an aluminum diamond plate kick panel installed to protect the lower portion of the entry doors. Exposed, raw, sheared, unfinished sheet-metal edges are not acceptable. The panels shall be fastened to the door with Phillips head stainless steel, #10-32 machine screws with rubber washers to assist in cushioning the impact of door closure. The kick panel shall measure approximately 8" x 20".

Does Your Bid Comply? Yes No Exceptions _____

8.3 DOOR JAMB: The door jamb shall be an extruded aluminum extrusion measuring approximately 2.725" x 3" with no less than .1875" wall thickness to accommodate rigid fastening of compartment door hinges, and the TriMark cage nut assemblies that are used to secure nadir pens. The corners of the extruded

door jamb shall be CNC mitered, fixture fit and welded full perimeter to hold the door opening square. The mounting and access points for the nadir pens shall be CNC routed for precision and repetitive consistency. The door jamb shall have a full perimeter flange that shall be secured to the body side skin with 3M panel bond adhesive rated at no less than 2,150PSI. The jamb shall also be secured with ¼" x 20 Type "F" self-tapping, stainless steel sheet metal screws installed around the full perimeter of the framed door opening into the wall structure that is welded into place around the door opening in the side wall structure. The jamb shall be CNC to accommodate the consistent placement of the TriMark cage nuts used to mount the Nader pins and for consistently locating the door hinge.

Does Your Bid Comply? Yes ____ No ____ Exceptions _____

8.4 HINGE: All doors shall have stainless steel, continuous, piano hinges. The pin diameter shall be .250" and staked into place to prevent drifting out of the hinge leaves. The knuckle lengths shall be 1". Alternating mounting slots shall be incorporated in the hinge to facilitate fine adjustment. The hinge attachment bolts shall be ¼" x 20 x 1" long stainless steel Type "F" pan head screws. The screws shall be spaced 4 inches apart on each leaf for the full length of the hinge. The tapping points along the door and jamb shall be designed in and CNC placed for consistently repetitive production and ease of replacement. The hinges for each individual door shall be identically cut for all common door heights and the CNC process used to fabricate the door and jamb shall insure that all of the door components are easily replaceable and interchangeable.

Does Your Bid Comply? Yes ____ No ____ Exceptions _____

8.5 LATCHES: All exterior door latches shall be TriMark two stage, rotary type latches that meet FMVSS 206 requirements for door locks and door retention components. The latches shall be through bolted to the door with 5/16 UNC countersink, machine type bolts and lock nuts that comply with the latch manufacturer's requirements. All entry doors shall have two rotary latches per door. To assure uniform latch timing and functional door reliability, only straight, 3/16" diameter rods shall connect the latches to the handle. All latch timing shall be set at the handle site. Other than at the latch site, bends in door latch rods are NOT acceptable.

The Nader pins for each door latch shall be installed through the door jamb into TriMark cage nut assemblies designed to be through bolted into the door jamb extrusion with grade 8 machine type bolts per the manufacturer's requirements. The cage nut assembly will support the mounting nut should the Nader pin need to be removed for maintenance or service.

All single, short compartment doors shall have one rotary latch. All double doors or tall compartment doors shall have two rotary latches per door. All Nader pins shall be headed to prevent the door(s) from opening under impact.

Does Your Bid Comply? Yes ____ No ____ Exceptions _____

8.6 EXTERIOR HANDLES: TriMark powder coated black finished, free floating exterior paddle handles shall be provided to open all doors. Blind fasteners shall be used to fasten the handles to the door. Exposed fasteners to the outside are unacceptable for security reasons. Paddle handles shall have an isolation gasket between the paddle body and the door skin. All door skin surfaces shall be CNC cut to produce a uniform fit and shall be painted prior to installation of the hardware. The handle shall be long enough to accommodate four gloved fingers for door actuation. All paddles on single doors and leading double doors shall be locking type and keyed the same. Trailing doors shall have non-locking paddle handles mounted on the interior door

panel. The inner side of all exterior handles shall have a strip of 3M Safety Grip material installed to provide a slip resistant surface in bad weather. When locked, the paddle handle shall “float” to prevent unnecessary pressure being applied which may damage the handle and function as a signal that the handle is locked.

The rotary latches for each door shall be fit with metal rods, individually clipped to both the latches and the paddle handles. The rods shall be designed to be adjustable; however, they will be secured when adjusted so that they cannot voluntarily move. The door latching assemblies as a whole shall be fully tested to comply with FMVSS 206 requirements including 30G testing, no exceptions. A copy of the testing certificate validating the door system and testing shall be provided with the bid.

Does Your Bid Comply? Yes _____ No _____ Exceptions _____

8.7 INTERIOR HANDLES: TriMark powder coated black matching interior paddle handles shall be supplied on all module entry doors. The interior handles shall be powder coated black.

Does Your Bid Comply? Yes _____ No _____ Exceptions _____

8.8 WINDOWS: All entry doors shall be equipped with an upper window. The curbside entry door shall have a fixed pane window with a nominal area of 320 square inches. The rear access doors shall each have a fixed pane window with a nominal area of 320 square inches. All windows shall have anodized frames and blind inner mounting ring screws, fastened from the inside. The exterior portion of the frame shall have a full perimeter seal mated against the door skin. All glass shall be dark tinted safety glass compliant with FMVSS 205.

Does Your Bid Comply? Yes _____ No _____ Exceptions _____

8.9 DOOR CHECKS: All doors shall be equipped with a door check (hold open). The curbside entry door and exterior compartment doors shall have a gas strut mounted type of door check. The gas strut shall keep positive pressure on the door in the open and closed position. Door check brackets shall be bolted through overhead structure to provide a solid attachment to the door frame. All doors shall open 90 to 110 degrees, unless otherwise specified by the user.

Rear access doors shall open at least 150 degrees. The door checks shall be two pieces, heavy duty grabber type assemblies. The door shall have a ½” thick cast aluminum loop that plunges into a positive rubber/cast aluminum socket mounted on the body. Each component of the door checks shall be insulated from the skin with a rubber gasket. Each door-check component shall be rigidly mounted on the door or body by ¼” x 20 stainless steel machine screws tapped in ¼” aluminum plates permanently mounted behind the skin to stabilize the grabber.

Does Your Bid Comply? Yes _____ No _____ Exceptions _____

8.10 ENTRY DOOR ASSIST HANDLES: All entry doors shall be equipped with two-point, 1” diameter stainless steel, “handicap” style grab handles to aid in door closure and entry assistance. The handles shall run horizontally, directly above the inside door paddle handle. The assist handles shall be fastened directly to the horizontal door structure that is welded into the door assembly.

Does Your Bid Comply? Yes _____ No _____ Exceptions _____

8.11 DRIP RAILS: A drip rail shall be provided over each compartment to prevent water roll off from spilling into the opened compartment door. Drip rails shall be attached with double-sided adhesive for ease of replacement. Full height compartments are exempt because the perimeter roof rail drip rails cover these compartments.

Does Your Bid Comply? Yes _____ No _____ Exceptions _____

9.0 COMPARTMENT CONSTRUCTION & CONFIGURATION

9.1 MATERIALS: All exterior compartment walls, back and floor shall be constructed of smooth aluminum and coated with a rubberized polyurethane coating, Herculiner or equivalent. The ceilings and floor components shall be CNC cut, formed and welded to provide overlapping joints. The floors and ceilings are both welded and seam sealed as necessary to the walls and back prior to applying the rubberized coating. The compartment shall be designed so that the floor to the compartment will be below the lower edge of the door jamb.

Does Your Bid Comply? Yes _____ No _____ Exceptions _____

9.2 COMPARTMENT CONFIGURATION: The exterior compartments on this vehicle shall be as illustrated in the drawings attached to this Specification:

Drawing A- Curbside

Drawing B- Streetside

Does Your Bid Comply? Yes _____ No _____ Exceptions _____

9.3 OXYGEN COMPARTMENT: An M-size cylinder retention bracket shall be provided to secure a vertically stored cylinder. The retention bracket shall be through bolted to the compartment wall backed by 1/2" aluminum plate with four 3/8-16 grade 8 bolts with grade 8 nuts. The retention bracket shall be powder coated steel and remain rust free for the life of the ambulance. The oxygen cylinder shall be attached to the bracket with three (3) spring-buckle, webbed retention straps. The retention bracket shall be in compliance with AMD Standard 003- Oxygen Tank Retention System Static Test.

Compartment #1 shall be approximately: 13.75"W x 63.75"H x 14"D

Does Your Bid Comply? Yes _____ No _____ Exceptions _____

9.4 #2 STORAGE COMPARTMENT: This compartment shall be located just aft of the O2 compartment on the streetside of the module. It shall be configured for general storage or as specified by this agency.

Compartment #1 shall be approximately: 26.75"W x 38.25"H x 14"D

Does Your Bid Comply? Yes _____ No _____ Exceptions _____

9.5 #3 STORAGE COMPARTMENT: This compartment shall be located aft of the rear wheel well on the streetside of the module. It shall be configured for Backboard storage.

Compartment #1 shall be approximately: 13.5"W x 78.75"H x 17.5"D

Does Your Bid Comply? Yes _____ No _____ Exceptions _____

9.6 #4 INSIDE/OUTSIDE COMPARTMENT: This compartment shall be located at the forward most curbside of the module. It shall be configured to provide exterior access to the interior ALS cabinet and the battery storage area located below the floor level of the ALS storage. There shall be a separate access door located below the floor level for maintenance and service to the vehicles battery storage area. Compartment #1 shall be approximately: 19"W x 57.75"H

Does Your Bid Comply? Yes _____ No _____ Exceptions _____

9.7 #7 SPARE TIRE STORAGE COMPARTMENT: This compartment shall be located at the curbside rear of the module. It shall be configured for vertical storage of the spare tire. There shall be a 2" nylon strap and buckle assembly for securing the spare tire in the compartment. Compartment #7 shall be approximately: 32.75"W x 25.75"H x 18"D

Does Your Bid Comply? Yes _____ No _____ Exceptions _____

10.0 CORROSION: Anti-electrolysis procedures

10.1 EXTERIOR FASTENERS: Dissimilar metal contact is known to cause corrosion at fastener sites. All exterior device fasteners, especially light fasteners, shall not contact the painted aluminum surface. All fasteners that are not aluminum or plastic bodied are considered dissimilar. Each hole drilled after the prime and paint process shall be treated with an electrolysis corrosion control compound, ECK or equivalent prior to installation of the mounting screws. All mounting screws shall be stainless steel and shall be coated with the electrolysis corrosion control compound prior to installation.

Does Your Bid Comply? Yes _____ No _____ Exceptions _____

11.0 REAR BUMPER

11.1 FRAMING: The rear step bumper shall meet or exceed KKK-A-1822F 3.9.6 and be compliant with AMD Standard 018. The bumper shall be a minimum 1/8" welded tubular steel frame with a 1/4" flange designed to be bolted directly to the chassis frame without cutting, drilling or welding. The frame shall be bolted with a minimum four 1/2" steel bolts, washers and nylon lock washers on each side. In addition the bumper will be configured so that the bottom of the bumper shall be mounted below the body skirt-line. The steel bumper frame shall be powder coated black for a durable, corrosive resistant finish.

Does Your Bid Comply? Yes _____ No _____ Exceptions _____

11.2 CENTER STEP: A flip up step shall be provided to allow closer access to the patient compartment floor. The step shall be as wide as the rear access door jamb. The step shall have a grip strut surface for aggressive traction. Snow and ice shall not compromise the level of traction on the center step. A stainless steel piano hinge shall have a staked in, 1/4" diameter pin, one inch knuckles and Type-F 1/4"-20 stainless steel bolts every four inches.

Does Your Bid Comply? Yes _____ No _____ Exceptions _____

11.3 OUTER BUMPER PODS: The step bumper shall have an aesthetically pleasing appearance. The outer bumper pods shall be polished aluminum diamond plate. The outer corners shall be rounded to eliminate sharp corners around the working area. Each pod shall have a heavy duty rubber rear dock bumper attached to further protect the bumper.

Does Your Bid Comply? Yes _____ No _____ Exceptions _____

12.0 BODY PROTECTION

12.1 FRONT OF BODY: The front of the body shall have protection plates made of aluminum diamond plate fitted between the contour of the cab and the corner posts. The corner posts shall have 12" high formed diamond plate protection panels.

Does Your Bid Comply? Yes _____ No _____ Exceptions _____

12.2 REAR OF BODY: An aluminum diamond plate kick panel shall run from rear corner post to corner post and house a recessed, cast aluminum, license plate holder. The kick panel shall be 12" in height and shall extend downward from below the rear door jamb to the bottom edge of the body. The corner posts shall have 12" high formed diamond plate protection panels.

Does Your Bid Comply? Yes _____ No _____ Exceptions _____

12.3 LOWER BODY RUB RAILS: The entire skirt-line of the body, forward and aft of the rear wheels shall have extruded aluminum "C" channel skirt rails installed to protect the edge of the lower body. Each rail shall be chamfered 45 degrees at each end. The rails shall be mounted with 1/4" x 20 stainless steel machine screws through 1/8" nylon spacers to prevent contact between the rub rail and the modular body. There shall be a 3/4" white reflective stripe installed down the center of the rub rail, full length.

Does Your Bid Comply? Yes _____ No _____ Exceptions _____

12.4 REAR ENTRY DOOR: At the rear entry doors, a full width, formed, stainless steel threshold protection plate shall be provided to prevent the cot frames from causing damage to the body and the entry level floor. The threshold shall have a high quality anti-skid material applied in full width strips to provide a slip resistant step into the patient compartment.

Does Your Bid Comply? Yes _____ No _____ Exceptions _____

12.5 SIDE ENTRY DOOR: An aluminum diamond plate threshold shall be installed at the transition point between the side entry step well and the patient compartment floor. The threshold shall have a high quality anti-skid material applied in full width strips to provide a slip resistant step into the patient compartment.

Does Your Bid Comply? Yes _____ No _____ Exceptions _____

12.6 FENDER FLARES: The rear fender flares shall be extruded rubber. The fender flares shall be through bolting around the wheel well opening with 1/4"-20 stainless steel pan head bolts coated with an anti-corrosion chemical.

Does Your Bid Comply? Yes _____ No _____ Exceptions _____

13.0 CABINetry

13.1 SUBSTRATES: The interior cabinets and components shall be constructed of high quality, domestic grade plywood. The exposed layers shall be hard wood on both sides of the sheet. The layers shall be free of

voids between layers. Cabinet interiors shall be made from 3/8" or 1/2" thick, 5-ply plywood determined by the application for each. Bench lids, doors and the primary cabinet fascia shall be made from 3/4" thick, 7-ply plywood.

Does Your Bid Comply? Yes ____ No ____ Exceptions _____

13.2 CABINET INTERIOR FINISH: Cabinet interior shall be laminated with white colored, high impact, abrasion resistant laminate. The contact adhesive shall be a high bond contact adhesive, specifically designed to bond plastic laminates to wood. Painted cabinet interiors are not acceptable.

Does Your Bid Comply? Yes ____ No ____ Exceptions _____

13.3 FLOOR AND SUBSTRATE: The sub floor of the module shall be 3/4" thick, 7-ply, marine grade plywood. The vinyl floor covering shall be Lonseal or Lonplate. The final color shall be determined after bid award.

Does Your Bid Comply? Yes ____ No ____ Exceptions _____

13.4 LAMINATE: A high impact, phenol backed, high impact, and abrasion resistant laminate shall be used. The laminate shall be selected from the ambulance manufacturer's samples. The material shall be standard grade. This material as well as all interior components shall meet or exceed F.M.V.S.S. #302 (Burn Rate of Interior Components).

Does Your Bid Comply? Yes ____ No ____ Exceptions _____

13.5 CABINET ASSEMBLY: To maximize fastener bite, cabinet substrate parts shall be stapled with pneumatic fired equipment. Staples shall be placed on two-inch intervals along the corner joints. In addition to staples, the entire cabinet assembly must be screwed together with a minimum #8 screw size and a length not less than 2 times the thickness of the pierced substrate. Screw heads shall be counter-sink type and driven flush. Cabinet fascia shall be CNC cut or drop cut to eliminate the use of cleats or stick built components. The use of stick built components or dowel pin type assembly to create cabinet components will not be acceptable.

Does Your Bid Comply? Yes ____ No ____ Exceptions _____

13.6 CABINET TRIM: All trim throughout the interior conversion shall be anodized aluminum or formed stainless steel. All exposed corners within the patient compartment shall have either padded or rounded corners. Excess adhesive-sealant shall be removed. Intermittent placement of screws is not acceptable due to cleaning difficulty inherent in screw head design.

Does Your Bid Comply? Yes ____ No ____ Exceptions _____

13.7 FIT AND FINISH: Mitered joints throughout the interior conversion shall have a gap-less, hairline fit. Openings and misalignments at the corners are not acceptable. Misapplied trim to cover manufacturing mistakes is not acceptable solutions to poor design and/or workmanship. Doors shall be warp free. Sliding polycarbonate door assemblies shall be scratch free and all edges shall be smooth and free of saw marks and sharp edges. Cabinet to cabinet joints shall not require more than 7/32" diameter wetting to create a finished/well-fit look. Cabinets shall fit tightly against the ceiling without the use of vinyl covered trim pieces to cover the seam between cabinets and ceiling.

Does Your Bid Comply? Yes ____ No ____ Exceptions _____

13.8 FUNCTION: Doors and drawers shall fit the opening. Flush fitting doors shall have even door to opening spacing around the perimeter. All doors shall open and close bind-free. Drawers shall slide in and out freely, without drag. All drawers shall be mounted on side mounted, full-extension drawer slides, rated at no less than 75 pounds per pair. All hinged wood-core doors shall have positive latches.

Does Your Bid Comply? Yes ____ No ____ Exceptions _____

13.9 SLIDING POLYCARBONATE DOORS: Polycarbonate shall hereinafter be identified as "Lexan". All interior cabinets requiring the sliding, transparent Lexan door assembly shall have a mitered, anodized aluminum frame. The Lexan shall be a minimum of 3/16 inch thick.

Each door shall be fitted with a full height, extruded aluminum door handle. The door pull extrusion shall also stiffen the ends of the doors. The door track/frame extrusion shall incorporate a flocked natural rubber track insert to prevent the doors from sliding free during transit. All extrusions shall be anodized.

Does Your Bid Comply? Yes ____ No ____ Exceptions _____

13.9 HINGED ACRYLIC DOORS: All interior cabinets requiring a hinged, transparent Acrylic door assembly shall have a 1/2" smoked acrylic door installed.

Does Your Bid Comply? Yes ____ No ____ Exceptions _____

14.0 CABINET CONFIGURATION

14.1 STREET SIDE: As required by this purchaser, a CPR seat shall be provided on the street side cabinet wall. The cabinets shall be easily accessible over the primary cot. The cabinet configuration and dimensions will be described in the CAD drawings attached to this Specification.

Does Your Bid Comply? Yes ____ No ____ Exceptions _____

14.2 CURB SIDE: A two position squad bench shall be installed. Two sets of EVS V-4 four point belts shall be supplied. The belts shall restrain two seated occupants or one secondary patient, on a back board. All seat belts and anchorages shall comply with F.M.V.S.S. 209 and 210. A padded back and head rest shall be supplied for all seated personnel along the squad bench. The cabinet configuration and dimensions shall comply with the drawings attached. Squad bench lid shall utilize gas struts as support when opened and shall have a positive paddle latch to hold the lid in the closed position.

Located in the forward section of the squad bench shall be a separate locking door with a drop in area for sharps and trash containers. Access to these containers shall be through a flip up Lexan lid – red in color and marked with the "BIOHAZARD" symbol.

A Cargo net Crash barrier shall be installed at the head of the squad bench.

Does Your Bid Comply? Yes ____ No ____ Exceptions _____

14.3 REAR OVERHEAD CABINET: A cabinet will be installed over the rear doors to provide additional storage the cabinet will have Lexan sliding doors and be configured as shown in the attached CAD drawings.

Does Your Bid Comply? Yes ____ No ____ Exceptions _____

14.4 RIGHT FRONT CABINET: The right front cabinet is hereinafter known as "ALS Cabinet". The ALS cabinet shall be finished in color keyed laminate. There shall be one lower locking cabinet at the floor level with an open storage area above and a single adjustable shelf. All areas in the ALS Cabinet shall be accessible from the exterior of the vehicle which will have a full height locking door.

Does Your Bid Comply? Yes ____ No ____ Exceptions _____

14.5 STREETSIDE WALL CABINERY:

Cabinet "A1" shall be located at the upper rear of the CPR seat. The cabinet shall have sliding Lexan doors and shall include 1 adjustable shelf. Cabinet "A1" shall be approximately 21.5"H x 32"W x 15"D

Cabinet "A2" shall be located at the mid-rear of the CPR seat. The cabinet shall have sliding Lexan doors and shall include 1 adjustable shelf. Cabinet "A2" shall be approximately 21.5"H x 32"W x 15"D

Cabinet "C" shall be located above the action area for storage of medical tubing, air ways, and ventilation face masks. This cabinet will hereinafter be described as the "Action Area Overhead cabinet". The Action Area Overhead cabinet shall have the dimensions as shown on the attached CAD drawings. The Action Area Overhead cabinet will include 1 adjustable shelf. Cabinet "C" shall be approximately 16.25"H x 34.25"L x 18"D.

The CPR seat shall be approximately 28"W. The seating area shall be equipped with a hinged lid for access to the storage area below the seat. The seat/lid shall include a 2" cushion approximately 20" x 20" and shall be secured by a TriMark powder coated black, recessed latch. The back wall of the seating area shall include a backrest approximately 20"W x 30"H. An automotive style EVS V-4 four point seat belt assembly shall be provided.

Does Your Bid Comply? Yes ____ No ____ Exceptions _____

14.6 ACTION AREA COUNTERTOP: The countertop surface shall be a color coordinated laminate. The edge of the action area shall have a lip to prevent items from sliding to the floor. Action areas will be located on both sides of the CPR seat. The action area forward of the CPR seat will hereinafter be called the EMSP Action Area. The action area shelf shall be approximately 34.5"L x 18"D.

Does Your Bid Comply? Yes ____ No ____ Exceptions _____

14.7 TECHNICIAN'S SEAT: The Technician's seat shall be steel framed, high back contoured style captain's chair with Type II lap/shoulder belt assembly. The seat shall be color matched to other upholstery within the patient compartment. The seat base shall be a black, powder coated steel box. The Technician's seat shall be fastened with Grade 8 fasteners through the top of the seat base which is secured with Grade 8 fasteners through the floor and through 3/4" aluminum mounting plates welded into the floor structure.

Does Your Bid Comply? Yes ____ No ____ Exceptions _____

14.8 WALK-THRU CABINETS: Located in the pass-thru of the module behind the Technician's Seat shall be two additional storage cabinets. These cabinets shall each be designated as general storage. The upper cabinet "D" shall be approximately 21.25"H x 11"W x 16.25"D. The lower cabinet "E" shall be approximately 21.25"H x 11"W x 16.25"D. Cabinet "E" shall include the onboard battery charger, the pre-wire for the inverter and the vacuum pump.

The lower cabinet shall be the mounting location for the inverter pre-wire and the electric vacuum pump. The upper cabinet shall be for general storage.

Does Your Bid Comply? Yes ____ No ____ Exceptions _____

14.9 WALK-THRU OVERHEAD CABINET: Located above the walk-thru area shall be two cabinets. One cabinet shall be for general storage and one shall be for the 12VDC electrical control panels. The cabinets shall both be fitted with hinged ¾" plywood doors and Southco chrome flip latches to secure the doors. The latch on the electrical cabinet shall be locking.

Does Your Bid Comply? Yes ____ No ____ Exceptions _____

14.10 OCCUPANT HEAD CLEARANCE ZONES: All designated occupant seating positions in the vehicle described in the Specification shall be in compliance with AMD Standard 025- Measuring Guidelines: Occupant Head Clearance Zones.

15.0 UPHOLSTERY

15.1 UPHOLSTERY MATERIALS: All padding and upholstered seating shall be covered in vacuum formed vinyl. Sewn, exposed seams in the seat covers and cushions are not acceptable.

The color shall be selected by the purchaser to coordinate with the laminate selected.

Does Your Bid Comply? Yes ____ No ____ Exceptions _____

15.2 SEAT / BACKREST CORE MATERIAL: The foam shall meet Federal Specification KKK-A-1822F 3.11.4. All seating and trim materials shall meet or exceed FMVSS 302- Flammability of Interior Materials.

Does Your Bid Comply? Yes ____ No ____ Exceptions _____

16.0 INTERIOR HARDWARE

16.1 OVERHEAD ASSIST RAIL: This rail shall be naturally accessible to assist working attendants in maintaining their balance. The rail shall meet or exceed Federal Specification KKK-A-1822F and comply with AMD Standard 008- Patient Compartment Grab Rail Static Load Test. The rail shall be approximately 1.25" diameter, handicap style, brushed stainless steel and 72" long. The rail shall be located over the primary patient.

Does Your Bid Comply? Yes ____ No ____ Exceptions _____

16.2 COT RETENTION DEVICE & PRIMARY COT: The main cot retention device shall be a Stryker Performance Load System located in the center position. The purchaser shall specify the model of cot to be

retained by the device. The installed cot retention device shall be in compliance with AMD Standard 004 and change notice #8 of the Federal Specification.

Does Your Bid Comply? Yes ____ No ____ Exceptions _____

16.3 MEDICAL EQUIPMENT POLE: To facilitate the mounting of miscellaneous medical equipment, i.e. IV-pump, etc., a stainless steel pole approximately 1" diameter shall be installed on the inboard rear corner of the Action Area. The equipment pole shall extend from the horizontal surface of the action area to the ceiling above and be secured top and bottom with circular stanchion feet screwed in place.

Does Your Bid Comply? Yes ____ No ____ Exceptions _____

17.0 OXYGEN, VACUUM SYSTEMS

17.1 MAIN OXYGEN SUPPLY: The manufacturer shall provide a certified cylinder mount designed for storage of one (1) M-sized oxygen cylinder. The cylinder and its retention components shall be located in the streetside front exterior compartment as specified in 9.3 of this Specification.

The Oxygen System shall also include a 50 PSI, pre-set Oxygen Regulator.

The retention bracket shall be positioned so that the cylinder's main valve and regulator are visible through a Lexan viewing window in the forward end of the EMSP Action Area.

Does Your Bid Comply? Yes ____ No ____ Exceptions _____

17.2 OXYGEN OUTLETS: The oxygen supply system shall be installed in the patient compartment in compliance with KKK-A-1822E. Unless otherwise specified, the system shall consist of three Ohio style oxygen outlets in raised trim rings. Two outlets shall be located on the action wall and one outlet shall be located on the forward end of the curb side wall above the squad bench. This system shall be set up so a change in outlet style is readily made by just removing the front plate, thereby not compromising integrity of the system with field changes.

Does Your Bid Comply? Yes ____ No ____ Exceptions _____

17.3 OXYGEN HOSES: All oxygen system service hoses, fittings and devices shall be made of non-ferrous materials. Hoses used to pipe Medical Oxygen shall be 1/4" inside diameter with an abrasion resistant, green colored, electrically conductive outer jacket. All hoses shall withstand a system test pressure of 200 PSI test as prescribed in Federal Specification KKK-A-1822F 4.4.1 and AMD Standard 015- Ambulance Main Oxygen System Test. Each ambulance shall be tested. "Type Testing/Certification" is not acceptable.

Does Your Bid Comply? Yes ____ No ____ Exceptions _____

17.4 VACUUM (SUCTION) SYSTEM: A 12-Volt DC electric vacuum pump shall be installed in the lower Pass-thru cabinet forward of the Technician's Seat. The pump shall meet performance guidelines set forth by Federal Specification KKK-A-1822F 3.12.2 and AMD Standard 021- Aspirator System Test, Primary Patient. A variable vacuum regulator and gauge panel shall be installed in the action area control panel. The vacuum regulator shall control the vacuum pressure delivered to a Rico RS-4X collection system with a disposable collection canister. The Vacuum gauge shall not be mounted on the collection canister but on the Action Area

wall and be hard-plumbed to the electric vacuum pump. Each ambulance shall be tested. "Type Testing/Certification: is not acceptable.

Does Your Bid Comply? Yes ____ No ____ Exceptions _____

18.0 ELECTRICAL SYSTEM – 12-Volt Direct Current

The 12 VDC Electrical system installed in this vehicle must comply with AMD Standard 005- 12-Volt DC Electrical System Test. This electrical System shall be covered under the manufacturer's Warranty for a period of 72 months (6 yrs) or 72,000 miles which ever shall occur first.

Does Your Bid Comply? Yes ____ No ____ Exceptions _____

18.1 BODY GROUNDING: A minimum of (2) two 1" wide braided ground straps shall be bolted through the chassis frame and the floor structure of the modular body. The bolts shall be 3/8" diameter. A flat washer shall be provided under the head of the bolt, over the strap lug and an internal tooth lock washer shall be installed under the lug to preclude loosening. Chassis frames with asphalt/wax coating or E-coating shall have grounding sites prepared by lightly grinding or sanding the coating away to reveal raw metal.

Does Your Bid Comply? Yes ____ No ____ Exceptions _____

18.2 GENERAL GROUNDS: To comply with federal specification KKK-A-1822F 3.7.12 plus enhance ground quality and reduce trouble shooting time, all devices wired within the ambulance conversion shall be centrally grounded on a ground bar located in the Electrical Cabinet. The ground bar is grounded to the chassis frame by a 2/0 AWG cable and attached in the same manner as the braided body ground cables. Each device shall have a separate ground wire routed to a central buss bar then grounded via fine strand cable to the module body.

Does Your Bid Comply? Yes ____ No ____ Exceptions _____

18.3 12 VOLT WIRE: All wires within the ambulance harnesses shall meet Federal Specification KKK-A-1822F 3.7.2 and 3.7.2.1. All wire insulation shall be GXL cross-linked polyethylene.

Permanent wire identification and wire function shall be stamped on 4" centers along the full length of the wire. Wire conductors shall be stranded copper. Single strand copper conductors are not acceptable due to vibration concerns and stiffness which promotes loosening of the terminals.

Does Your Bid Comply? Yes ____ No ____ Exceptions _____

18.4 WIRE PROTECTION: All wire within the conversion shall be protected and run in split-convoluted loom with a melting temperature of 300 degrees Fahrenheit. All wire harnesses shall be clamped and routed to eliminate possibility of damage due to cut/chaffed wire. Grommets made of rubber or plastic shall be used where harnesses pass through metal or wood. Large holes and irregular shaped wire passages shall use automotive edge trim to protect the wire conduit/loom. Wire harnesses shall be neatly clamped into protective routing areas away from heat sources, unfriendly edges or moving devices.

Does Your Bid Comply? Yes ____ No ____ Exceptions _____

18.5 CIRCUIT BREAKERS: All conversion 12VDC circuits shall be protected by non-proprietary, manual reset, circuit breakers. The trip value for the breaker shall not exceed 80% of the amperage rating of the weakest component in the circuit. Branch circuit wire sizes shall be rated 125% of the expected load per KKK-A-1822F 3.7.2.1.

Does Your Bid Comply? Yes _____ No _____ Exceptions _____

18.6 12 VOLT DC OUTLETS: Two 12 Volt DC, 20 Ampere, cigarette style outlets shall be supplied; one (1) in the action area and one (1) in the ALS compartment. Each outlet shall be separately protected and shall be electrically isolated from other electrical functions on the vehicle. The outlets shall be wired per Federal Specification KKK-A-1822F 3.7.7.3.

Does Your Bid Comply? Yes _____ No _____ Exceptions _____

18.7 DUAL 2 AMP USB OUTLETS: There shall be a dual Vanner 2 Amp USB charging receptacle mounted next to the 12VDC receptacle on the action area wall.

Does Your Bid Comply? Yes _____ No _____ Exceptions _____

19.0 ELECTRICAL SYSTEM- 125 VOLT Alternating Current

19.1 The 125 VAC Electrical System described in this Specification shall comply with AMD Standard 009-125-Volt AC Electrical Systems Test. This electrical System shall be covered under the manufacturer's Warranty for a period of 72 months (6 yrs) or 72,000 miles which ever shall occur first.

Does Your Bid Comply? Yes _____ No _____ Exceptions _____

19.2 PRIMARY SHORELINE INLET: The 1125V electrical system shall be furnished with a 125VAC 20 amp straight blade shore power inlet incorporating a male plug and shall be located on the street side of the module aft of the #1 compartment and above the #2 compartment. The inlet shall have a spring-loaded, weather proof cover. The circuit shall be ground fault and circuit breaker protected incorporating a manual reset switch control (GFI) with a UL approved QO type single phase load center located behind the driver seat in the cab. All 125VAC wiring shall be 12 gauge. All 125 volt AC wiring connections shall be made in UL approved junction boxes. A battery charger pigtail with female plug will be routed to the battery charger prewire area.

A permanent, aluminized vinyl label, stating voltage and amperage shall be located above the inlet in compliance with KKK-A-1822F 3.7.8, 3.7.8.1.

Does Your Bid Comply? Yes _____ No _____ Exceptions _____

19.3 INVERTER PRE-WIRE: The vehicle shall include a complete pre-wire for a 1200 watt maximum 'UL' listed inverter with internal transfer relay and battery conditioner. The pre-wire shall include a wired connection to the shoreline inlet and output wiring to all 125 Volt AC outlets provided in the vehicle. There shall be a single on/off switch located on the rear action panel. This pre-wiring shall be in accordance to KKK-A-1822F 3.7.8.3 and Section 250-6 (Portable and Vehicle Mounted Generators) of the National Electrical Code (NEC).

Does Your Bid Comply? Yes _____ No _____ Exceptions _____

19.4 INVERTER: A VANNER 1050 Watt Inverter with 55 amp battery charger shall be installed in the lower Pass-thru cabinet and wired to the vehicle battery system and to the 125 VAC shoreline power system.

Does Your Bid Comply? Yes ____ No ____ Exceptions _____

19.5 125 OUTLET No.1: A 125 Volt, Hospital grade, Straight blade outlet shall be provided on the wall of the main Action Area. The outlet must be grounded and protected by a G.F.I. (Ground Fault Interrupter) Breaker. The outlet must illuminate a green indicator light when power is applied to the outlet.

Does Your Bid Comply? Yes ____ No ____ Exceptions _____

19.6 125 OUTLET No. 2: A 125 Volt, Hospital grade, Straight blade outlet shall be provided in the ALS cabinet. The outlet shall be grounded and protected by a G.F.I. (Ground Fault Interrupter) Breaker. The outlet must illuminate a green indicator light when power is applied to the outlet.

Does Your Bid Comply? Yes ____ No ____ Exceptions _____

20.0 ENVIRONMENTAL

20.1 REAR AIR CONDITIONING: The design of the environmental system is to provide optimal air flow and distribution of conditioned air to the module interior. Conditioned air shall be discharged from one vent area and shall be distributed through five vents evenly spaced across the face of the upper section of the ALS cabinet. The module shall have an additional, self-contained A/C evaporator unit complete with dual blower, motor driven, high output fans. The fans shall be three speeds and shall contain a 720 CFM fan. The A/C unit shall also incorporate a hot water heater core for heat. All heater hoses shall be 3/4 inch QVM approved Nomex for improved circulation. Hot water flow shall be controlled by one (1) vacuum actuated inline water valves. All A/C fittings shall be ferruled, banded, or snap ring type. Clamps will not be acceptable.

The valves shall operate with the heater/defrost controls. The unit shall be rated at least 32,000 British Thermal Units (BTU) in A/C Mode and 36,000 BTU in Heater Mode. The Vehicle A/C – Heater system must meet or exceed federal specification KKK-A-1822F 3.13.1 thru 3.13.3 and must be compliant with AMD Standards 011- Equipment Temperature Test, 012- Interior Climate Control Test.

Does Your Bid Comply? Yes ____ No ____ Exceptions _____

20.2 REAR AC CONTROLS: An ON/OFF switch shall be located in the action area. The aforementioned switch will not control fan speed, but indicate the selection of Heat/Off/Cool. A separate three-speed fan speed control switch shall be located in the action area control panel. Temperature settings shall be controlled by a simple rheostat controlled thermostat mounted on the Action Area switch panel.

Does Your Bid Comply? Yes ____ No ____ Exceptions _____

20.3 HVAC SYSTEM INSTALLATION & WARRANTY:

The auxiliary heating and air conditioning system shall be installed in the ambulance at the ambulance manufacturer's facilities by technicians employed by the manufacturer of the HVAC equipment. Said technicians shall document the installation on forms provided by the HVAC manufacturer and on forms required by the ambulance manufacturer. Warranty on the installation of, and the equipment content and performance of the equipment, shall be the sole responsibility of the HVAC manufacturer.

Does Your Bid Comply? Yes _____ No _____ Exceptions _____

21.0 CONSOLES, SWITCH PANELS

21.1 CAB CONSOLE: The ambulance conversion control console shall be ergonomically designed, CNC cut, formed, welded and powder coated. The body of the console shall be a textured flat black to avoid glare and resist abrasion. The console shall be removed from the OEM floor. The console shall include an electronic siren, the driver's control/switch panel, two cup holders and slots for maps or work books.

The siren control head and contoured switch panel shall be within easy reach of the passenger and driver.

Does Your Bid Comply? Yes _____ No _____ Exceptions _____

21.2 SWITCH PANEL, CAB CONSOLE: A switch panel made from a thick, composite/acrylic sheet shall be installed on the forward end of the floor console. All switches and controls shall have back lighted legends indication function and status. The Switch Panel shall have the following minimum controls and indicators:

- | | |
|---------------------------------------|----------------------------|
| 1. Compartment Open indicator | 8. Rear Flood Switch |
| 2. Battery On indicator | 9. Right Flood Switch |
| 3. Door Open indicator | 10. Back-Up Alarm Switch |
| 4. MASTER Emergency Switch, red bezel | 11. Spare |
| 5. Primary Secondary Mode Switch | 12. Digital Volt/Amp Meter |
| 6. Siren/Horn Switch | |
| 7. Left Flood Switch | |

Does Your Bid Comply? Yes _____ No _____ Exceptions _____

21.3 SWITCH PANEL, ACTION AREA: A switch panel made from a thick, composite/acrylic sheet shall be installed on the outboard wall of the Action Area. All switches and controls shall have back lighted legends indication function and status. The Switch Panel shall have the following minimum controls and indicators:

- | | |
|--------------------------------------|-----------------------------|
| 1. Dome Lights, Cot Switch (Hi/Lo) | 6. AC/Heat Selector Switch |
| 2. Dome Lights, Bench Switch (Hi/Lo) | 7. AC/Heat Fan Speed Switch |
| 3. Vacuum System Switch, red bezel | 8. Digital Clock |
| 4. Exhaust Vent Switch | 9. Spare Switch |
| 5. Inverter | 10. Thermostat |

Does Your Bid Comply? Yes _____ No _____ Exceptions _____

22.0 VISUAL CONSPICUITY - EXTERIOR LIGHTING

22.1 WARNING LIGHTS: The warning light system shall meet or exceed KKK-A-1822F as demonstrated with the documentation provided by the lighting manufacturer.

Unless otherwise specified, the warning lights shall be configured like, and flash in compliance with, KKK-A-1822F 3.8.2.1, and Table 1.

22.2 DUAL MODE FLASHERS: A dual mode Primary/Secondary flasher shall be provided for the vehicle emergency warning light system as required in KKK-A-1822F. Lights shall be configured as depicted in the attached drawings and as described below:

22.2.1 FRONT WALL: The front wall shall be configured with seven Whelen 900 Series LED warning lights mounted on the front of the body. The lights shall be configured as follows – R/C/R/C/R/C/R. All of the lenses shall be clear. These lights shall be wired to flash in primary/secondary modes as required.

22.2.2 WARNING LIGHTS- DRIVER SIDE: There shall be (2) Whelen 900 Series Red LED warning lights mounted on the driver side of the module. (1) In the upper forward and (1) in the upper rearward corners of the module. The lenses shall be clear.

22.2.3 WARNING LIGHTS- PASSENGER SIDE: There shall be (2) Whelen 900 Series Red LED warning lights mounted on the passenger side of the module. (1) In the upper forward and (1) in the upper rearward corners of the module. The lenses shall be clear.

22.2.4 WARNING LIGHTS– REAR: The ambulance shall be equipped with (3) Whelen 900 Series LED warning lights positioned on the upper module rear wall. The halogen shall be configured as follows: Red/ /Amber/ /Red. The lenses shall be clear.

22.2.5 REAR MID-BODY WARNING LIGHTS: This unit shall be equipped with (2) Whelen 900 Series Red LED warning lights mounted on the rear of the module set to show through the rear door windows when the rear doors are open. These halogen lights shall be Red and shall be wired to function as brake lights when not in emergency mode. The lenses shall be clear.

22.2.6 GRILLE LIGHTS: This unit shall be equipped with (2) Whelen LINZ6R Series Red Super LED warning lights mounted on the upper chrome cross bar of the OEM grille in compliance with the OEM chassis manufacturer's guidelines and the lighting requirements of KKK-A-1822F. These LEDs shall function in the primary mode only. The lenses shall be clear.

22.2.7 INTERSECTION LIGHTS – CAB: This unit shall be equipped with (2) Whelen 700 Series Red LED warning lights mounted in the forward area of the chassis front fenders in compliance with the OEM chassis manufacturer's guidelines and the lighting requirements of KKK-A-1822F. These warning lights shall function in the primary mode only. The lenses shall be clear.

Does Your Bid Comply? Yes _____ No _____ Exceptions _____

22.3 TAIL LIGHTS: Tail light configuration shall be Whelen 7"x3" LED Tail/Brake, Turn Signals and Back-up Lights installed w/ chromed bezels. These lights shall be stacked vertically above the diamond plate rear kick plate in the order presented above.

Does Your Bid Comply? Yes _____ No _____ Exceptions _____

22.4 I.C.C. LIGHTS: 3/4" round LED clearance lights shall be provided per FMVSS and D.O.T. Standards. The lights shall indicate the height and width of the vehicle and define the vehicle centerline. These lights will be mounted on the uppermost margins of the front and rear body. The lights shall be mounted in rubber grommets and the mounting location for each light shall be prepared prior to the paint process to reduce the possibility of paint break and resulting corrosion. Drilling or tapping through a painted body shall not be acceptable. There shall be five (5) amber clearance lights (Optronics LED model MCL11CAB) forward facing and five (5) red clearance lights (Optronics LED model MCL11CRB) rear facing. Additionally there shall be two (2) matching amber D.O.T. marker/directional lights mounted one (1) each side of the module on the rear corner extrusions and two (2) matching red D.O.T. marker lights mounted one (1) each side of the module on the rear corner extrusions. The D.O.T. marker lights shall be located approximately 48" above ground level.

Does Your Bid Comply? Yes _____ No _____ Exceptions _____

22.5 LICENSE PLATE LIGHT: The license plate holder shall be a cast aluminum housing that is near flush mounted on the rear of the module. The housing shall be mounted in the lower diamond plate kick panel below the street side B/T/T lighting. There shall be two (2) LED lights installed to provide illumination to the license plate with the chassis park light circuit on.

Does Your Bid Comply? Yes _____ No _____ Exceptions _____

22.6 SCENE LIGHTS: Two Whelen 900 series scene lights shall be provided on each side of the module. The curbside lights shall come on when the curbside entry door is opened.

The streetside and curbside scene lights may be turned ON/OFF with (2) two separate, right and left scene rocker switches located on the cab console switch panel. There will be a momentary disconnect switch located at the side entry door for disabling the scene lights during the daylight hours.

Does Your Bid Comply? Yes _____ No _____ Exceptions _____

22.7 LOAD LIGHTS: Two Whelen 900 series halogen load lights shall illuminate the rear of the module. Both rear lights shall come on with the opening of the leading rear access door. These rear load lights will also activate when the vehicle transmission is placed in reverse or when the rear load switch in the cab console switch panel is activated. There will be a momentary disconnect switch located on the wall at the curb side rear entry door for disabling the load lights during the daylight hours.

Does Your Bid Comply? Yes _____ No _____ Exceptions _____

22.8 PERIMETER LIGHTING CERTIFICATION: To assure that the exterior work lighting is adequate to perform EMS functions in a variety of settings which may require exterior illumination, the Scene and Load lights installed on this vehicle shall comply with AMD Standard 024- Perimeter Illumination Test.

Does Your Bid Comply? Yes _____ No _____ Exceptions _____

22.9 SPOT LIGHT: A hand held 400,000 candle power, blue-eye spot light shall be provided in the cab. A chromed hook with spring retainer shall be included to stow the light.

Does Your Bid Comply? Yes _____ No _____ Exceptions _____

22.10 COMPARTMENT LIGHTING: The compartments shall be illuminated with Optronics ILL36CB LED Compartment lights. The lights shall function each time the compartment door is opened and extinguish when the door is closed. The lights shall be located: (1) Ceiling of Compt #1; (2) in Compt #2- (1) URH, (1) LLH; (1) in ceiling of Compartment #3; (2) in Compt #4/5; (1) in Compt #6.

Does Your Bid Comply? Yes _____ No _____ Exceptions _____

23.0 AUDIBLE CONSPICUITY

23.1 ELECTRONIC SIREN: The ambulance shall be equipped with an ignition powered Carson SA 500 200 watt siren mounted in the engine cover console.

There shall be a set of CPI polished cast aluminum 100 watt speakers mounted through the bumper on the outboard ends. The siren speakers shall not block air-flow into the grille per the OEM chassis manufacturer's guidelines. The siren and speakers shall meet or exceed KKK-A-1822F 3.14.4 and be compliant with AMD Standard 023- Siren Performance Test and AMD Standard 006- Patient Compartment Sound Level Test.

Does Your Bid Comply? Yes No Exceptions _____

23.2 BACK UP ALARM: The apparatus shall include a minimum 97 decibel back up alarm device. The alarm shall be automatically activated by shifting the vehicle transmission into reverse. The backup alarm shall include a rocker type cut-off switch located in the cab console Switch Panel. The alarm device shall be provided as required in KKK-A-1822F 3.15.2 and shall be compliant with SAE Standard J994.

Does Your Bid Comply? Yes No Exceptions _____

24.0 INTERIOR LIGHTING

24.1 ACTION AREA LIGHTING: A 12-volt LED light shall be provided directly over the forward, street side work surface. A near flush, 18 inch type fixture shall be provided. The light shall have an on-off rocker switch on the body of the light housing.

Does Your Bid Comply? Yes No Exceptions _____

24.2 STEPWELL ILLUMINATION: A 12 VDC LED light shall illuminate the curbside stepwell per Federal Specification KKK-A-1822F 3.10.12.

Does Your Bid Comply? Yes No Exceptions _____

24.3 PATIENT COMPARTMENT DOME LIGHTS: The patient compartment shall have eight 8" Whelen 18 diode LED dome lights in the ceiling. The lights shall be arranged in two longitudinal rows of (4) lights each. The streetside row shall provide light directly over the patient; the curbside row shall provide light directly over the aisle and squad bench. The four curbside lights shall be activated when the side or rear module entrance doors are opened on a five minute timer circuit. The dome lights and configuration shall meet KKK-A-1822F 3.8.4, 3.8.4.1 and be compliant with AMD Standard 016- Patient Compartment Lighting Level Test.

Does Your Bid Comply? Yes No Exceptions _____

24.4 CHECK-OUT TIMER: A 5 minute check-out timer shall activate by opening the rear or side entry door when the battery switch is off. The curbside bank of dome lights shall turn on in the "high" mode. Following the first 5-minute cycle the lights will deactivate. The cycle can be reactivated by closing, then re-opening the side or rear entry door.

Does Your Bid Comply? Yes No Exceptions _____

25.0 COMMUNICATIONS EQUIPMENT

25.1 COMMUNICATIONS RADIO ANTENNA PRE-COAX: The vehicle shall be equipped with two (2) RG58-U coaxial cables with termination location to be determined by the purchaser. A 12VDC power and ground lead shall also be provide for each coaxial cable. There shall be an 18" service loop at the starting point and a 36"

termination loop. The radio power wires shall originate in the power distribution area and will be labeled appropriately for future installation by a radio technician.

Does Your Bid Comply? Yes _____ No _____ Exceptions _____

26.0 PAINT, LETTERING, DECALS, MISCELLANEOUS

26.1 100% PAINTFILM COVERAGE: All stages of primer and paint shall cover all weather-exposed surfaces. Hinge mating surfaces on the doors and jambs shall be painted. Bare aluminum and primer-only preparation is not acceptable under door hinges. Doors shall be painted without actuation handles installed. All body cutouts for emergency lighting, shoreline receptacle, etc., shall be cut prior to initiating the prime/paint process to assure complete coverage of all exposed, raw metal.

All of the module entry and compartment doors shall be removed prior to painting and be painted separately, at the same time and identically to the module process to insure complete coverage and electrolysis protection between the stainless steel hinge and the aluminum door and frame surfaces.

To reduce the risk of breaking paint and to provide a for a more consistently robust paint application, all light holes, the license plate bracket hole, gas filler bracket hole, all door window and handle holes and exhaust fan and any other option required mounting holes shall be cut in the module prior to beginning the paint process. Intersection light holes shall be cut in the chassis fenders and cut out must be coated with a corrosion resistant material to comply with Ford QVM requirements to prevent oxidation and rusting of the OEM metal surface.

The manufacturer's standard paint process shall provide that all surface body welds and imperfections be ground flush and body filled as needed to provide a smooth even surface that facilitates a flat smooth paint finish.

The entire exterior surface of the module shall be sanded with an air powered DA sander and a minimum 150 grit sand paper and then the module shall be washed with DX-330 cleaner/degreaser to remove any metal, oil or contaminant residue prior to the application of the seam seal process.

All exterior body seams shall be sealed with 3M panel bond/seam sealer to provide a smooth application environment for the prime and paint processes and to prevent future contamination, oxidation and corrosion.

The entire exterior surface of the module shall be coated with a primary coat of PPG "Delfleet" etch-coat primer, flash dried and then coated with a high performance PPG "Delfleet" primer sealer and baked to dry. The primer sealer coat shall be sanded to a flat smooth finish to eliminate all nibs and imperfections, inspected and etch primer/sealer applied where necessary and washed with DX330 to provide a clean, smooth surface prior to the application of the base coat application.

The entire exterior surface of the module shall be coated with an application of PPG "Delfleet" color mixed base coat. The base coat shall be baked to dry and inspected for imperfections. Minor surface repairs shall be utilized to provide a smooth surface prior to the application of the clear coat material. The entire exterior surface of the module shall be coated with an application of a PPG - "Delfleet" clear coat finish that will provide a robust, durable finish. The clear coat finish shall be baked per PPG "Delfleet" process instructions prior to the finished surface process application.

After the clear coat process is completed, the entire exterior surface of the module shall then be sanded with a minimum 1200 grit sand paper and then buffed using 3M Perfect-It III buffing compound to provide a clean, high gloss final surface finish.

Without exception, the manufacturer shall monitor the entire application process. The inspection process shall provide mil-thickness measurements at numerous random locations across the body to insure that the total paint process shall provide a minimum of 5 mils dry build, without runs or sags, after the completion of the final sand and buff process.

Does Your Bid Comply? Yes ____ No ____ Exceptions _____

26.2 PAINT AND COLORS: Unless otherwise specified, the module shall be painted white to match chassis. The graphics package to be included in this bid shall match the existing Fleet of ambulances in Roane County EMS. Any painting performed by the manufacturer, of the body and/or chassis, shall be covered under warranty for a period of not less than four (4) years / forty eight (48) months, and shall be sanctioned by the paint manufacturer.

Does Your Bid Comply? Yes ____ No ____ Exceptions _____

26.3 LETTERING & DECALS: Federal Specification KKK-A-1822F "Star-of-Life" and "Ambulance" lettering shall be Optional.

The following labels shall be provided as standard.

Notice: This vehicle Equipped with 12VDC charging System (Mounted in cab)

'Shore Inlet 125VAC 60 HZ'

'125VAC Outlet'

'12VDC Outlet'

'Diesel Only' or 'Gasoline Only' (per chassis requirements)

'No Smoking/Oxygen Equipped'

(2) 'Fasten Seat Belt' signs provided: (1) located in the cab and (1) in the module.

Does Your Bid Comply? Yes ____ No ____ Exceptions _____

26.4 FIRE EXTINGUISHERS: In compliance with the Federal Specification KKK-A-1822F, there shall be two (2) 5lb. ABC rated fire extinguishers with mounting brackets. These extinguishers shall be shipped loose with the completed ambulance for installation by this agency.

Does Your Bid Comply? Yes ____ No ____ Exceptions _____

27 REFERENCES AND STANDARDS

27.1 MANUALS

A Medix Owner's Manual copied onto a CD along with the OEM chassis manufacturers supplied items shall be provided with each vehicle. The information on the disc consists of the following items:

1. Chassis Warranty Card & Owner's Information
2. Chassis Maintenance and Operating Tips
3. Extra Set of Keys
4. 15 Year Module Warranty
5. 1 Year/12,000 mile Conversion Warranty

6. 6 Year/72,000 mile Electrical Warranty
7. 4 Year Paint Warranty
8. Care and Maintenance Instruction
9. Heater/AC Information & Warranty
10. OEM Chassis Manual
11. Schematics for Standard Systems:
 - Charging System
 - Power Distribution
 - Front Switch Panel
 - Rear Switch Panel
 - Climate Control System
 - OEM Drawings
 - Wire Harness list
 - Circuit Diagrams for all Systems
12. Conversion Component Information
13. Operations Manual
14. Warranty and Parts List - Siren, Etc.

Does Your Bid Comply? Yes _____ No _____ Exceptions _____

27.2 VEHICLE DRAWINGS

The following drawing views shall be provided:

1. Street side Exterior Detail
2. Curbside Exterior Detail
3. Front & Rear Exterior Detail
4. Street side Interior Detail
5. Curbside Interior Detail
6. Front & Rear Interior Detail
7. Overhead Floor Detail
8. Overhead Ceiling Detail

Does Your Bid Comply? Yes _____ No _____ Exceptions _____

ALL WARNING, SCENE, AND TAIL LIGHTS TO HAVE CHROME BEZELS
 ALL GREEN DIMENSIONS ARE TAKEN FROM EDGE OF WALL
 SURFACE PRIOR TO CORNER CAP BEING APPLIED

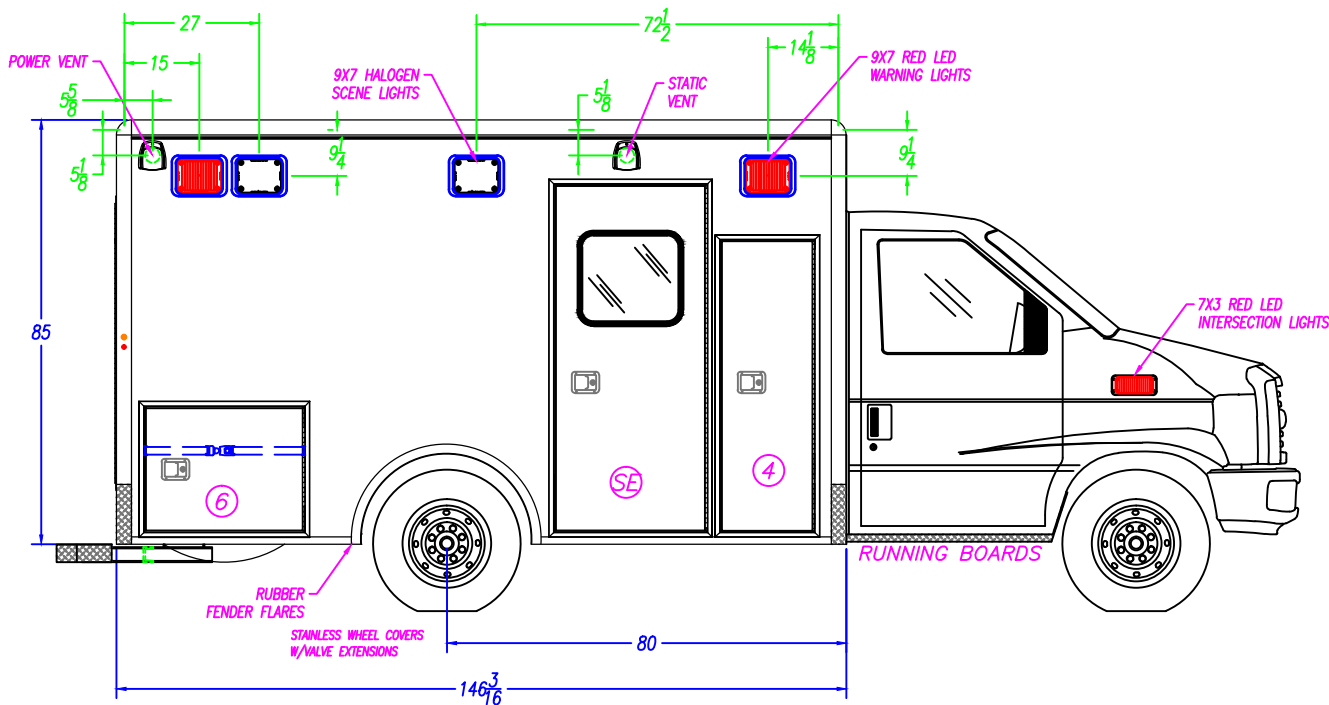

COMPARTMENT SIZES				NOTE: THE DIMENSIONS BELOW ARE OVERALL INTERIOR SIZES FOR EACH SPECIFIED COMPARTMENT TUB				COMPARTMENT & ENTRY DOORS				COMPARTMENT TUBS			
NO.	COMPARTMENT TYPE	WIDTH	HEIGHT	DEPTH	NO.	PART NUMBER	NO.	PARTNUMBER	NO.	PART NUMBER	NO.	PARTNUMBER	NO.	PARTNUMBER	
4	ALS/BATTERY COMPARTMENT	19 3/8"	15 3/8"	17 1/2"	4	71-A10910	-	---	4	41-101372	-	---	-	---	
6	OPTIONAL SPARE TIRE COMPARTMENT	32 1/4"	25 1/4"	12"	6	71-A10907	-	---	6	41-101226	-	---	-	---	
-	---	---	---	---	SE	71-A10908	-	---	-	---	-	---	-	---	
COMPARTMENT / ENTRY DOOR SIZES				FORD E-350 138" W.B. 146" RP90-ES TYPE III				<div style="display: flex; align-items: center;"> <div> <p>3008 MOBILE DRIVE ELKHART, IN 46514 PH: 574-266-0911 FAX: 574-266-6669</p> <p>"LET US SHOW YOU THE MEDIX DIFFERENCE" WWW.MEDIXAMBULANCE.COM</p> </div> </div>							
NO.	COMPARTMENT / ENTRY DOOR TYPE	WIDTH	HEIGHT	DESCRIPTION: CURB SIDE EXTERIOR											
4	ALS/BATTERY COMPARTMENT DOOR	18"	58 1/8"	DRAWN BY: D.EDWARDS	DATE CREATED: 3/3/16	SCALE: 5/16"=1'									
6	OPTIONAL SPARE TIRE COMPARTMENT DOOR	31 3/8"	24 3/8"	REVISED BY: NAME	DATE REVISID: DATE	REVISION: ---									
SE	SIDE ENTRY DOOR	29 1/4"	69 1/8"	Note: Drawings are for reference only, measurements may vary from actual product.											

ALL WARNING, SCENE, AND TAIL LIGHTS TO HAVE CHROME BEZELS
 ALL GREEN DIMENSIONS ARE TAKEN FROM EDGE OF WALL
 SURFACE PRIOR TO CORNER CAP BEING APPLIED

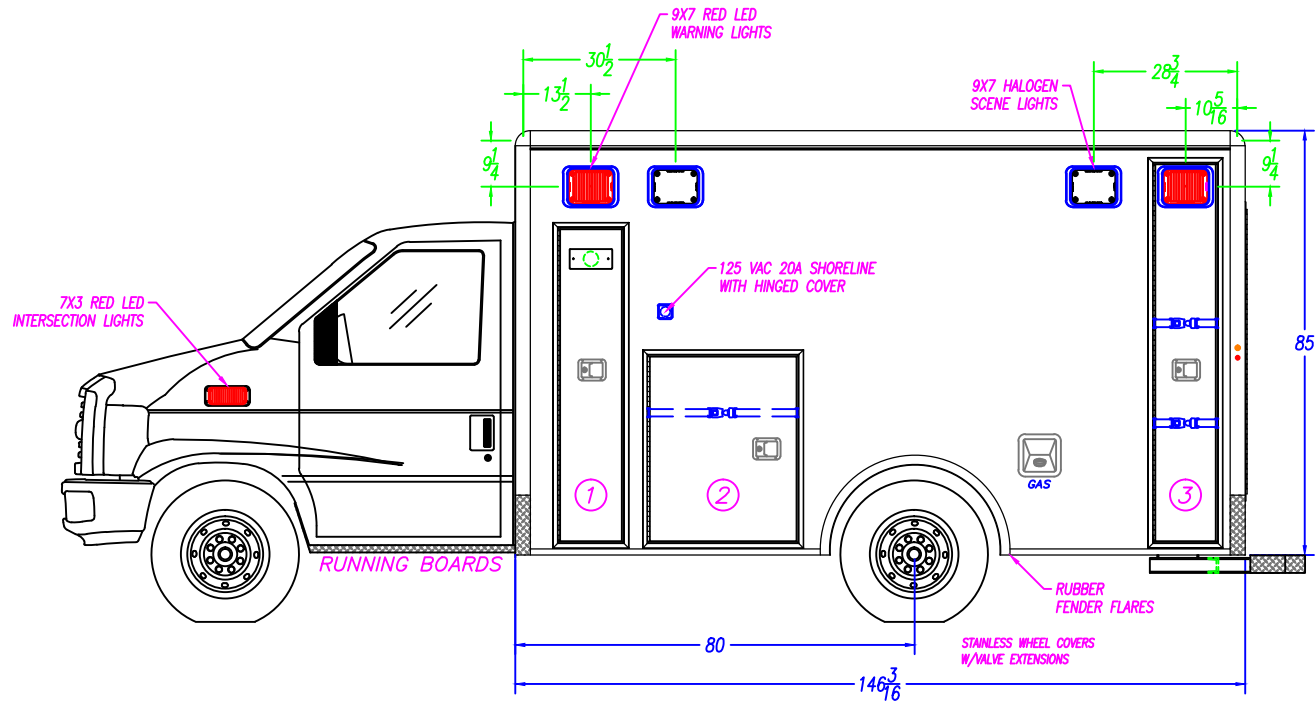

COMPARTMENT SIZES				NOTE: THE DIMENSIONS BELOW ARE OVERALL INTERIOR SIZES FOR EACH SPECIFIED COMPARTMENT TUB				COMPARTMENT & ENTRY DOORS				COMPARTMENT TUBS			
NO.	COMPARTMENT TYPE	WIDTH	HEIGHT	DEPTH	NO.	PART NUMBER	NO.	PARTNUMBER	NO.	PART NUMBER	NO.	PARTNUMBER			
1	O2 COMPARTMENT	13 7/8"	63 7/8"	13 3/4"	1	71-A10901	-	---	1	41-101222	-	---			
2	MID STORAGE COMPARTMENT	30 7/8"	38 3/8"	13 3/4"	2	71-A10903	-	---	2	41-101227	-	---			
3	BACKBOARD STORAGE COMPARTMENT	13 3/8"	76 7/8"	17 3/4"	3	71-A10904	-	---	3	41-101224	-	---			
				FORD E-350 138" W.B. 146" RP90-ES TYPE III											
COMPARTMENT / ENTRY DOOR SIZES				STREET SIDE EXTERIOR				<p>3008 MOBILE DRIVE ELKHART, IN 46514 PH: 574-266-0911 FAX: 574-266-6669</p> <p>"LET US SHOW YOU THE MEDIX DIFFERENCE" WWW.MEDIXAMBULANCE.COM</p>							
NO.	COMPARTMENT / ENTRY DOOR TYPE	WIDTH	HEIGHT	DRAWN BY:	DATE CREATED:	SCALE:									
1	O2 COMPARTMENT DOOR	12 1/2"	62 3/8"	D.EDWARDS	3/3/16	5/16"=1'									
2	MID STORAGE COMPARTMENT DOOR	29 1/2"	37 1/8"	REVISED BY:	DATE REVISED:	REVISION:									
3	BACKBOARD STORAGE COMPARTMENT DOOR	12 1/4"	74 5/8"	NAME	DATE	-									
				Note: Drawings are for reference only, measurements may vary from actual product.											

ALL WARNING, SCENE, AND TAIL LIGHTS TO HAVE CHROME BEZELS
 ALL GREEN DIMENSIONS ARE TAKEN FROM EDGE OF WALL
 SURFACE PRIOR TO CORNER CAP BEING APPLIED

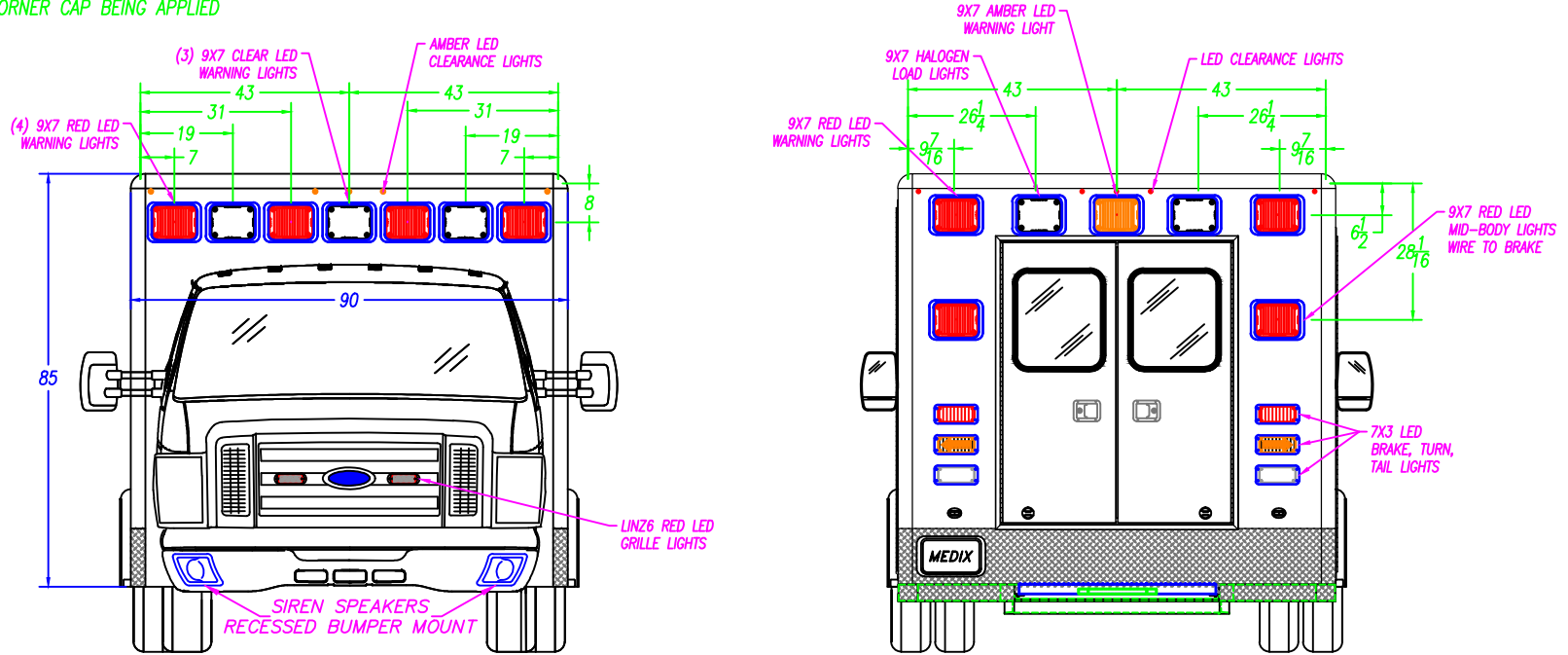

REAR ENTRY DOOR SIZES				FORD E-350 138" W.B. 146" RP90-ES TYPE III		
NO.	WIDTH	HEIGHT	PART NUMBER	FRONT & REAR EXTERIOR		
R1	---	---	---	DRAWN BY: D. EDWARDS	DATE CREATED: 3/3/16	SCALE: 5/16"=1'
R2	---	---	---	REVISED BY: NAME	DATE REVISED: DATE	REVISION: -

Note: Drawings are for reference only, measurements may vary from actual product.

3008 MOBILE DRIVE
 ELKHART, IN 46514
 PH: 574-266-0911
 FAX: 574-266-6669

"LET US SHOW YOU THE MEDIX DIFFERENCE"
 WWW.MEDIXAMBULANCE.COM

Dealer: MEDIX

Approved By:

Date:

Customer: ROANE COUNTY

16-BID

Sheet
D

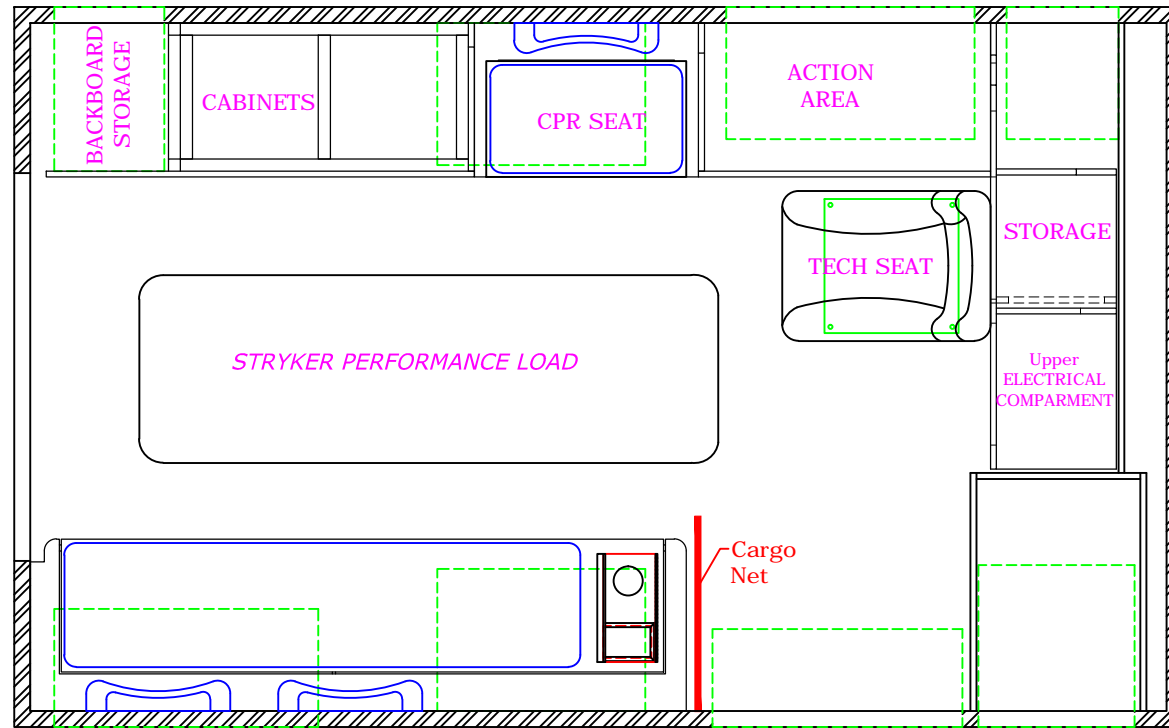

FORD E-350 138" W.B.
146" RP90-ES TYPE III

PATIENT AREA PLAN

DESCRIPTION:		
DRAWN BY: D. EDWARDS	DATE CREATED: 3/3/16	SCALE: 1/2"=1'
REVISED BY: NAME	DATE REVISID: DATE	REVISION: -

Note: Drawings are for reference only, measurements may vary from actual product.



MEDIX
SPECIALTY VEHICLES, INC.

3008 MOBILE DRIVE
ELKHART, IN 46514
PH: 574-266-0911
FAX: 574-266-6669

"LET US SHOW YOU THE MEDIX DIFFERENCE"
WWW.MEDIXAMBULANCE.COM

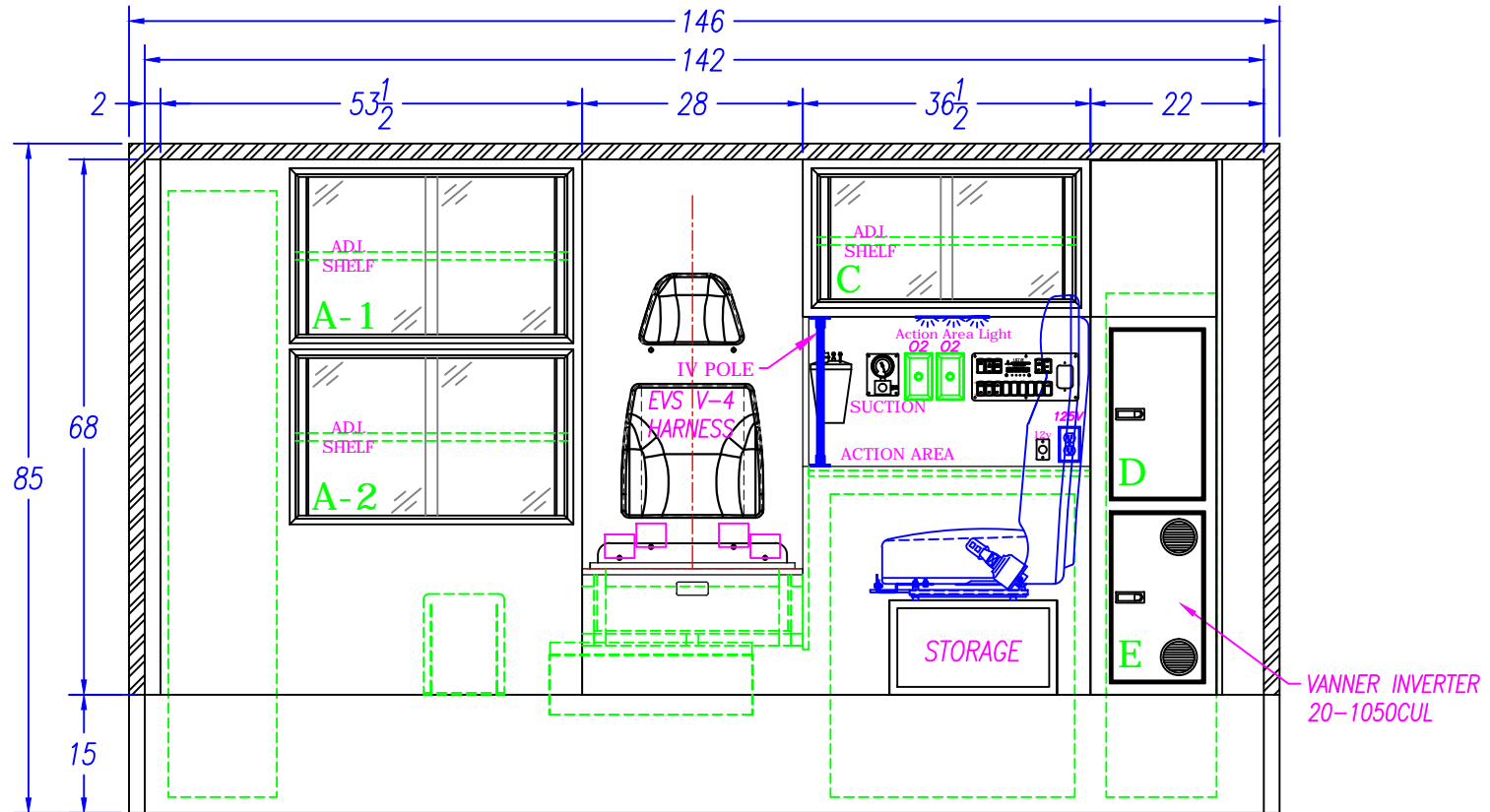

INTERIOR CABINET STORAGE				FORD E-350 138" W.B. 146" RP90-ES TYPE III	
ITEM	HEIGHT	WIDTH	DEPTH	SPECIAL NOTE	
A-1	20 3/4"	34 1/2"	15"		
A-2	20 3/4"	34 1/2"	15"		
C	16 1/4"	32 3/4"	15"		
D	21 1/2"	11"	16 1/4"		
E	21 1/2"	11"	16 1/4"		
F					

STREET SIDE INTERIOR		
DRAWN BY: D. EDWARDS	DATE CREATED: 3/3/16	SCALE: 1/2"=1'
REVISED BY: NAME	DATE REVISION: DATE	REVISION: -
Note: Drawings are for reference only, measurements may vary from actual product.		

	3008 MOBILE DRIVE ELKHART, IN 46514 PH: 574-266-0911 FAX: 574-266-6669
"LET US SHOW YOU THE MEDIX DIFFERENCE" WWW.MEDIXAMBULANCE.COM	

Dealer: MEDIX

Approved By:

Date:

Customer:

ROANE COUNTY

16-BID

Sheet
F

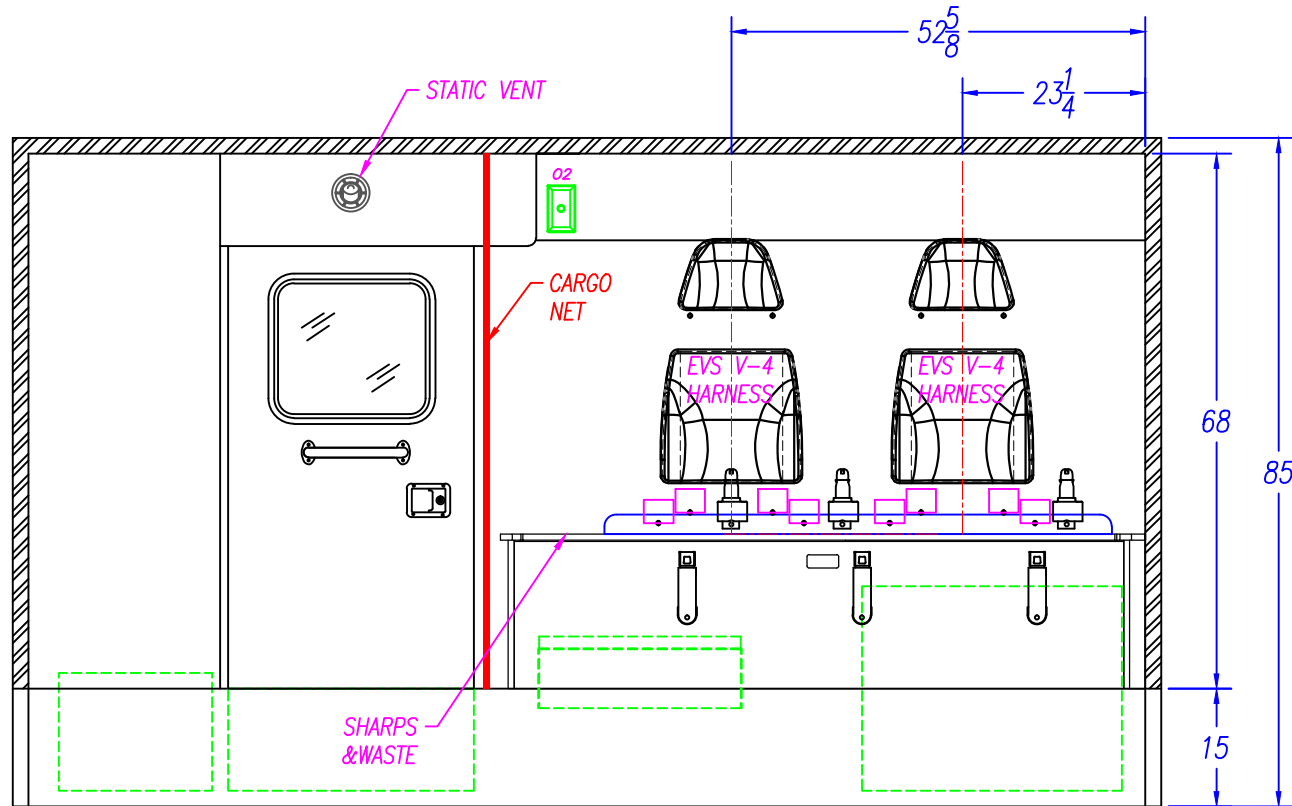

4" SEATBELT PLATE LOCATION

WELD SHOP	30	INCHES	NOTE: THIS DIMENSION IS FROM THE BOTTOM OF THE WALL TO THE BOTTOM OF THE 4" PLATE.			
CABINET SHOP	NOTE: THE HOLES FOR THE TOP SEATBELT HOLES ARE 1 1/2" FROM THE TOP OF THE SQUAD BENCH TO THE CENTER OF THE SEATBELT BOLT. NOTE: THE HOLES FOR THE BOTTOM SEATBELT BOLTS ON THE SQUAD BENCH ARE 9 3/8" FROM THE TOP OF THE FLOOR TO THE CENTER OF THE BOLT.					
NOTE: READ THE DIMENSIONS FROM RIGHT TO LEFT AS VIEWED	THE LOCATION OF THE BOTTOM SEATBELT HOLES ARE FROM THE REAR OF THE SQUAD BENCH TO THE CENTER OF THE 1/2" HOLE	BOTTOM		58 1/4"	36"	13 3/4"
	THE LOCATION OF THE TOP SEATBELT HOLES ARE FROM THE REAR WALL TO THE CENTER OF THE 1/2" HOLE	TOP		52 5/8"	38 1/2"	10"

INTERIOR CABINET STORAGE

ITEM	HEIGHT	WIDTH	DEPTH	SPECIAL NOTE
A				
B				
C				
D				
E				
F				

FORD E-350 138" W.B. 146" RP90-ES TYPE III		
DESCRIPTION: CURB SIDE INTERIOR		
DRAWN BY: D. EDWARDS	DATE CREATED: 3/3/16	SCALE: 1/2"=1'
REVISED BY: NAME	DATE REVISED: DATE	REVISION: -
Note: Drawings are for reference only, measurements may vary from actual product.		

3008 MOBILE DRIVE
ELKHART, IN 46514
PH: 574-266-0911
FAX: 574-266-6669

"LET US SHOW YOU THE MEDIX DIFFERENCE"
WWW.MEDIXAMBULANCE.COM

Dealer: MEDIX

Approved By:

Date:

Customer: ROANE COUNTY

16-BID

Sheet
G

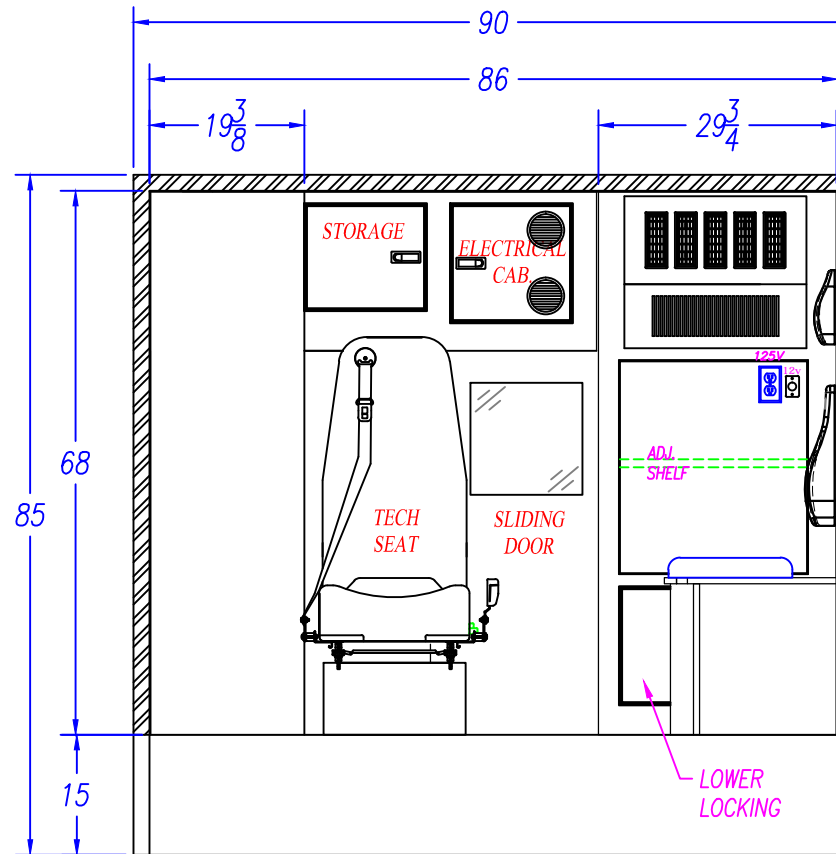

FORD E-350 138" W.B.
146" RP90-ES TYPE III

DESCRIPTION:

FRONT ELEVATION

DRAWN BY:
D. EDWARDS

DATE CREATED:
3/3/16

SCALE:
1/2"=1'

REVISED BY:
NAME

DATE REVISID:
DATE

REVISION:
-

Note: Drawings are for reference only, measurements may vary from actual product.



3008 MOBILE DRIVE
ELKHART, IN 46514
PH: 574-266-0911
FAX: 574-266-6669

SPECIALTY VEHICLES, INC.

"LET US SHOW YOU THE MEDIX DIFFERENCE"
WWW.MEDIXAMBULANCE.COM

Dealer: MEDIX

Approved By:

Date:

Customer: ROANE COUNTY

16-BID

Sheet
H

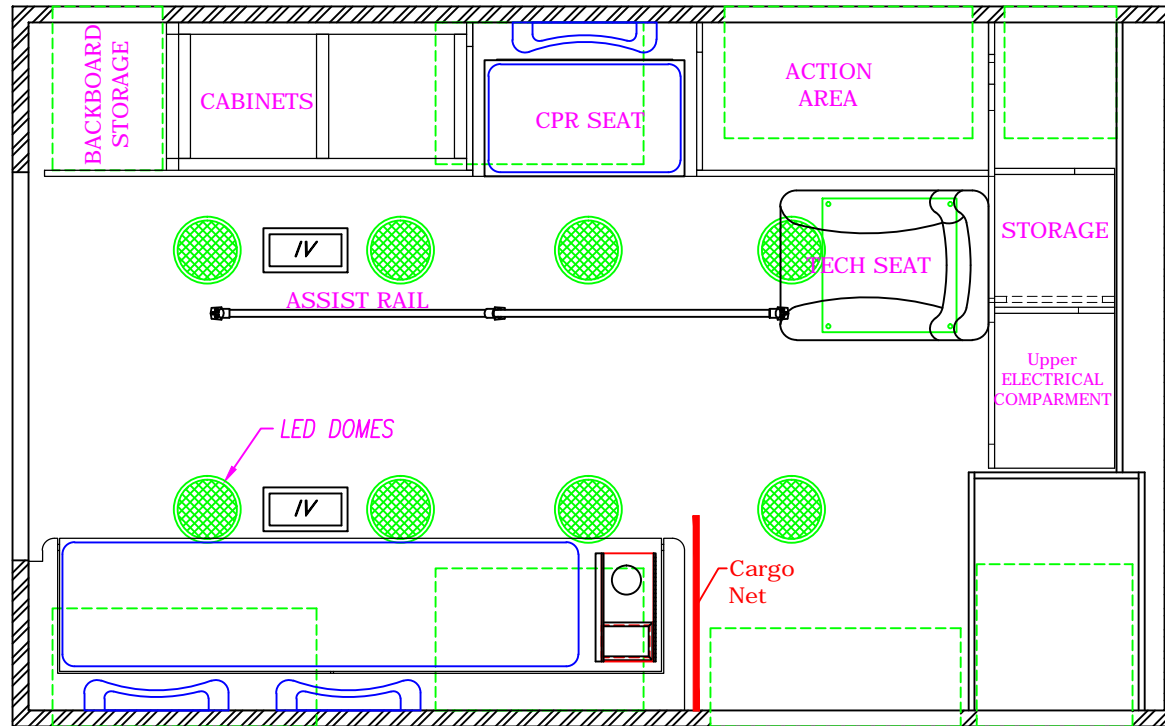

FORD E-350 138" W.B.
146" RP90-ES TYPE III

CEILING LAYOUT

DRAWN BY: D. EDWARDS			DATE CREATED: 3/3/16			SCALE: 1/2"=1'		
REVISED BY: NAME			DATE REVISID: DATE			REVISION: -		

Note: Drawings are for reference only, measurements may vary from actual product.



3008 MOBILE DRIVE
ELKHART, IN 46514
PH: 574-266-0911
FAX: 574-266-6669

"LET US SHOW YOU THE MEDIX DIFFERENCE"
WWW.MEDIXAMBULANCE.COM

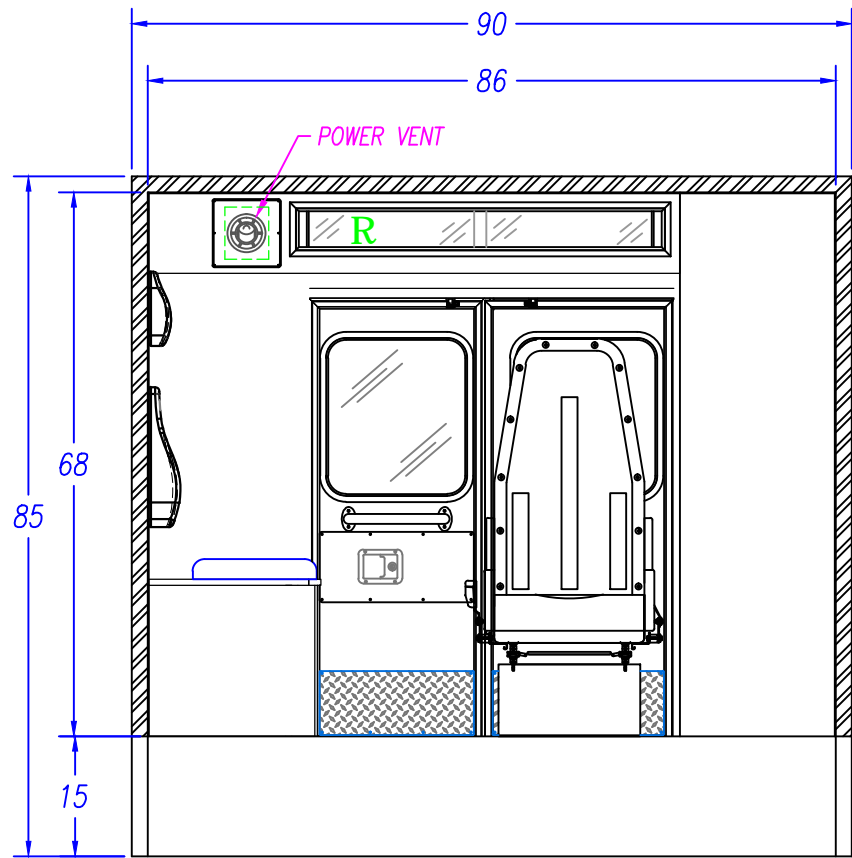

INTERIOR CABINET STORAGE					FORD E-350 138" W.B. 146" RP90-ES TYPE III		
ITEM	HEIGHT	WIDTH	DEPTH	SPECIAL NOTE	DESCRIPTION: REAR ELEVATION		
R	5 1/4"	46"	7"		DRAWN BY: D. EDWARDS	DATE CREATED: 3/3/16	SCALE: 1/2"=1'
					REVISED BY: NAME	DATE REVISID: DATE	REVISION: -
					Note: Drawings are for reference only, measurements may vary from actual product.		

MEDIX
SPECIALTY VEHICLES, INC.

3008 MOBILE DRIVE
ELKHART, IN 46514
PH: 574-266-0911
FAX: 574-266-6669

"LET US SHOW YOU THE MEDIX DIFFERENCE"
WWW.MEDIXAMBULANCE.COM