

PROJECT NAME
FIRE STATION ADD/ALTER, B3321

PROJECT NO.
PROJECT NO. 1039839

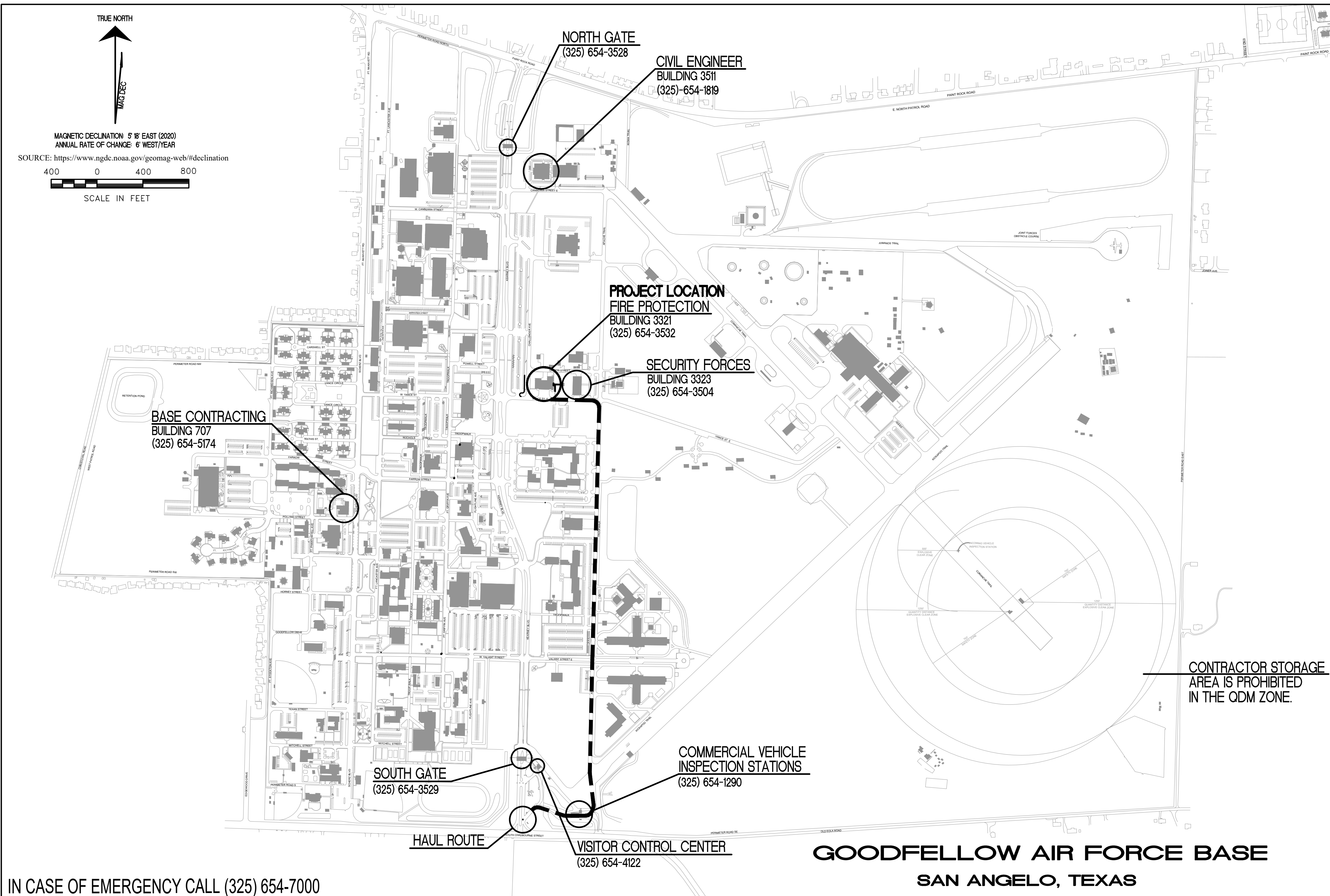

IN CASE OF EMERGENCY CALL (325) 654-7000

- GENERAL NOTES**
- PROSPECTIVE OFFERERS SHALL ONLY CONTACT THE TEXAS GRANT ADMINISTRATOR/PROJECT MANAGER, TOM GREEN COUNTY, 113 WEST BEAUREGARD AVE. SAN ANGELO, TX, 76903, (325)-657-8060 FOR ANY AND ALL INFORMATION WITH REGARDS TO THIS SOLICITATION.
 - ALL WORK SHALL BE NEW, UNUSED, AND OF INDUSTRY-WIDE QUALITY OR AS INDICATED HEREIN, WHICHEVER IS OF THE HIGHEST QUALITY. THE CONTRACTOR SHALL BE RESPONSIBLE FOR FIELD VERIFYING ALL EXISTING DIMENSIONS, CONDITION, AND EQUIPMENT PRIOR TO START OF WORK.
 - THE CONTRACTOR SHALL INITIATE AND PROCESS FOR APPROVAL AF FORM #103 "WORK CLEARANCE REQUEST" FOR THE CONTRACTING OFFICER PRIOR TO PERFORMANCE OF ON-SITE WORK.
 - LOCATIONS OF EXISTING UTILITIES ARE APPROXIMATE. THE CONTRACTOR SHALL FIELD VERIFY EXACT LOCATIONS PRIOR TO EXCAVATION OR TRENCHING. IT SHALL BE THE RESPONSIBILITY OF THE CONTRACTOR TO LOCATE SERVICE LINES AS REQUIRED FOR CONSTRUCTION FOR THIS PROJECT.
 - THE CONTRACTOR SHALL HAND DIG WITHIN (2) FEET EITHER SIDE OF UTILITY CROSSING UNTIL THE UTILITY IS PHYSICALLY EXPOSED, PRIOR TO PERFORMING MECHANICAL TRENCHING OR EXCAVATING. CONTRACTOR SHALL PROVIDE NEW TOPSOIL AND HYDROMULCHING IN ALL AREAS WHERE DISTURBED OR DAMAGED BY CONSTRUCTION ACTIVITIES.
 - PROSPECTIVE OFFERERS ARE HIGHLY ENCOURAGED TO ATTEND THE SCHEDULED PRE-PROPOSAL SITE VISIT TO THOROUGHLY FAMILIARIZE THEMSELVES WITH ANY AND ALL EXISTING SITE AND PROJECT LOCATION CONDITIONS WHICH MAY AFFECT THE WORK UNDER THIS CONTRACT. THE GOVERNMENT SHALL NOT BE RESPONSIBLE FOR CONTRACTOR ERRORS OR OMISSIONS WHICH COULD BE MADE KNOWN BY ATTENDING A SCHEDULED SITE VISIT.
 - THE CONTRACTOR SHALL COORDINATE ALL COMMUNICATIONS WORK WITH THE ENGINEERING SECTION MANAGER AT FRONTIER COMMUNICATIONS AT 1-800-921-8102; WITH THE INSTALLATION OFFICE, SUDENLINK CABLE AT 1-877-794-2724 AND THE GOODFELLOW AFB COMMUNICATIONS SQUADRON AT 325-654-3010.
 - THE CONTRACTOR SHALL INITIATE AND PROCESS FOR APPROVAL AF FORM #103 "WORK CLEARANCE REQUEST" TO THE GOODFELLOW AFB ASSIGNED PROJECT MANAGER PRIOR TO PERFORMANCE OF ON-SITE WORK. SITE UTILITIES THAT ARE LOCATED AND MARKED BY THE GOVERNMENT SHALL BE MAINTAINED BY THE CONTRACTOR.

- PROJECT NOTES**
- THE CONTRACTOR SHALL MAINTAIN A CONSTRUCTION SITE NEAT AND CLEAN OF DEBRIS AS DIRECTED BY THE CONTRACTING OFFICER. THE CONTRACTOR'S WASTE DUMPSTERS SHALL BE EMPTIED ON A REGULAR BASIS. ROADWAYS SHALL BE CLEAR OF DIRT AND DEBRIS. THE CONTRACTOR SHALL WATER-DOWN AREA FOR DUST CONTROL.
 - THE CONTRACTOR SHALL PROVIDE AND MAINTAIN SILT FENCING AROUND THE LIMITS OF CONSTRUCTION SITE. SILT FENCING SHALL ALSO BE PROVIDED AROUND AREA STORM DRAINAGE SURFACE INLETS. AT THE POST CONSTRUCTION PHASE, THE CONTRACTOR SHALL BE RESPONSIBLE FOR THE REMOVAL OF ALL MATERIALS RELATED TO THE PROJECT SILT FENCING TO INCLUDE ACCUMULATED DEBRIS. THE CONTRACTOR SHALL BE RESPONSIBLE FOR BRINGING THE AREA AROUND ALL SILT FENCING BACK TO THEIR ORIGINAL CONDITION PRIOR TO THE INSTALLATION OF SAID FENCING AND PROJECT CONSTRUCTION. THE CONTRACTOR SHALL MAINTAIN RECORDS OF THE ORIGINAL CONDITION OF THE SITE. SUCH RECORDS SHALL BE IN THE FORM OF COLOR PHOTOGRAPHS THAT SHALL BE KEPT ON FILE AS WELL AS TRANSMITTED TO THE GOVERNMENT FOR SAFE KEEPING.
 - THE CONTRACTOR SHALL INSTALL AND MAINTAIN A 6'-0" TALL TEMPORARY CONSTRUCTION CHAIN-LINK FENCE AROUND THE LIMITS OF WORK, NOT INCLUDING THE CONSTRUCTION ACCESS ROAD. COORDINATE CHAINS AND PADLOCKS ON GATES WITH GOODFELLOW FIRE DEPARTMENT. EACH GATE SHALL BE NUMBERED FOR EMERGENCY ACCESS AND SHALL HAVE INGRESS/EGRESS SIGNAGE AND AREA LIGHTING. THE CONTRACTOR SHALL MAINTAIN FIRE ACCESS THROUGH EACH INDIVIDUAL CONSTRUCTION SITE AT ALL TIMES.
 - TRUCK WASHOUT AREA SHALL BE CONSTRUCTED, MAINTAINED, AND CLEANED IN ACCORDANCE WITH TCEQ REGULATIONS. PROVIDE DETAILS AND MAINTENANCE PLAN AS PART OF THE STORMWATER POLLUTION PREVENTION PLAN. STORMWATER PERMITS SHALL BE REQUIRED PRIOR TO THE START OF CONSTRUCTION.
 - ALL CONTRACTORS SHALL STOCKPILE REQUIRED MATERIALS AND EQUIPMENT WITHIN THE LIMITS OF RESPECTIVE PROJECT AREAS OR STAGING AREA AS INDICATED ON THE DRAWINGS.
 - ALL HAUL ROADS SHALL BE MAINTAINED SUCH THAT UNOBSTRUCTED ACCESS SHALL BE PROVIDED AT ALL TIMES FROM THE ROAD TO THE STAGING AREA AND FROM THE STAGING AREA TO THE WORK SITE AND FACILITATE GOVERNMENT ACCESS TO THE BASE AT ALL TIMES. THE MAINTENANCE OF HAUL ROADS SHALL BE THE RESPONSIBILITY OF THE CONTRACTOR AT NO ADDITIONAL COST TO THE GOVERNMENT. THE HAUL ROAD LOCATIONS SHALL BE AS INDICATED ON THE STAGING/LAYDOWN AND ACCESS PLAN, OR BY THE CONTRACTING OFFICER.
 - THE CONTRACTOR SHALL COORDINATE ACTIVITIES THROUGHOUT THE PROJECT IN A MANNER THAT ALLOWS EMERGENCY ACCESS TO ALL EXISTING ROADWAYS AT ALL TIMES WITHOUT DELAYS TO EMERGENCY VEHICLES RESPONSE TIME.
 - WHILE WITHIN GOODFELLOW AFB, THE CONTRACTOR SHALL COMPLY WITH BASE REGULATIONS PERTAINING TO "NO FIREARMS" AND "NO ILLEGAL DRUGS."
 - ONLY RUBBER-TIRED VEHICLES SHALL BE ALLOWED ON EXISTING PAVEMENT THAT IS TO REMAIN IN PLACE.
 - ALL CONTRACTOR OPERATIONS SHALL BE CONDUCTED AND PERFORMED WITHIN ACCORDANCE OF DEPARTMENT OF LABOR OSHA REQUIREMENTS FOUND IN 29 CFR 1910.146 AND 1910.147 AND 29 CFR 1926, AND AIR FORCE OCCUPATIONAL SAFETY AND HEALTH [AFOSH] AND AIR FORCE INSTRUCTION [AFI] STANDARDS INCLUDING AFI 91-303, AIR FORCE CONSOLIDATED OCCUPATIONAL SAFETY INSTRUCTION. THE CONTRACTOR SHALL ALSO ENSURE THAT ALL WORK IS PERFORMED IN ACCORDANCE WITH PROJECT IDENTIFIED NATIONAL STANDARDS, MILITARY MANUALS, PAMPHLETS, INSTRUCTIONS, STANDARDS, HANDBOOKS AND WITH THE CORPS OF ENGINEERS [COE] SAFETY MANUAL 385-1-1 [EDITION IN EFFECT ON THE DATE OF THIS SOLICITATION]. ALL PROJECT SITES SHALL BE SUBJECT TO INSPECTION BY THE DEPARTMENT OF LABOR. IN THE EVENT OF CONFLICT BETWEEN THE OSHA STANDARDS AND THESE REQUIREMENTS, THE MOST STRINGENT SHALL APPLY.
 - AT ALL TIMES, THE CONTRACTOR SHALL MAINTAIN ONE FIRE LANE FREE OF OBSTRUCTION AND MAINTAIN ACCESS TO THE SITE AND ALL SURROUNDING ROADS AND STREETS.
 - GRASS AND WEEDY VEGETATION WITHIN THE AREAS UTILIZED BY THE CONTRACTOR, INCLUDING WORK AREAS, ADMINISTRATIVE AREAS AND STORAGE AREAS SHALL BE MOWED WHEN THE GRASS AND WEEDY VEGETATION IS AT A HEIGHT OF 6 INCHES, MOWING SHALL BE TO A HEIGHT OF 3 INCHES. MOWING SHALL BE ACCOMPLISHED WITH A ROTARY MOWER THAT LEAVES THE CLIPPINGS EVENLY DISTRIBUTED ON THE SOIL SURFACE. MOWING SHALL BE ACCOMPLISHED DURING PERIODS AND IN SUCH A MANNER THAT THE SOIL AND GRASS SHALL NOT BE DAMAGED. TOWED OR SELF-PROPELLED RIDING MOWERS SHALL NOT BE OPERATED WITHIN 3 FEET OF TREES OR SHRUBS. AREAS ADJACENT TO TREES AND SHRUBS SHALL BE MOWED WITH HAND-PROPELLED MOWERS.
 - EROSION CONTROL DEVICES SHALL BE USED FOR STAGING AREAS AND MATERIAL STOCKPILES WHEN NECESSARY TO CONTROL EROSION AND STORMWATER RUNOFF IN ACCORDANCE WITH FEDERAL, STATE AND LOCAL REGULATIONS. A SWPPP SHALL BE SUBMITTED PRIOR TO MOBILIZING.

DATE	SIGNATURE
	RECOMMENDED (BCE)
	SUBMITTED (PROGRAMS CHIEF)
	FIRE CHIEF
	SAFETY
	ASSET MANAGEMENT
	BIO-ENVIRONMENTAL OFFICER
	SECURITY FORCES
	COMMUNICATIONS
	CHIEF OF OPERATIONS
	PROGRAM DEVELOPMENT
	PROGRAM MANAGEMENT
	PROJECT MANAGER
	USING AGENCY
	USING AGENCY

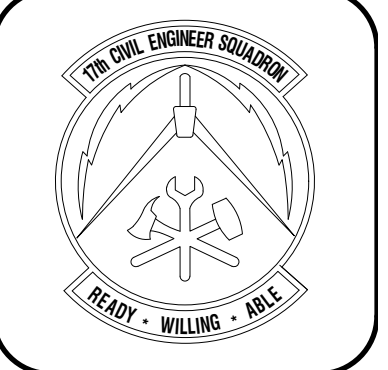
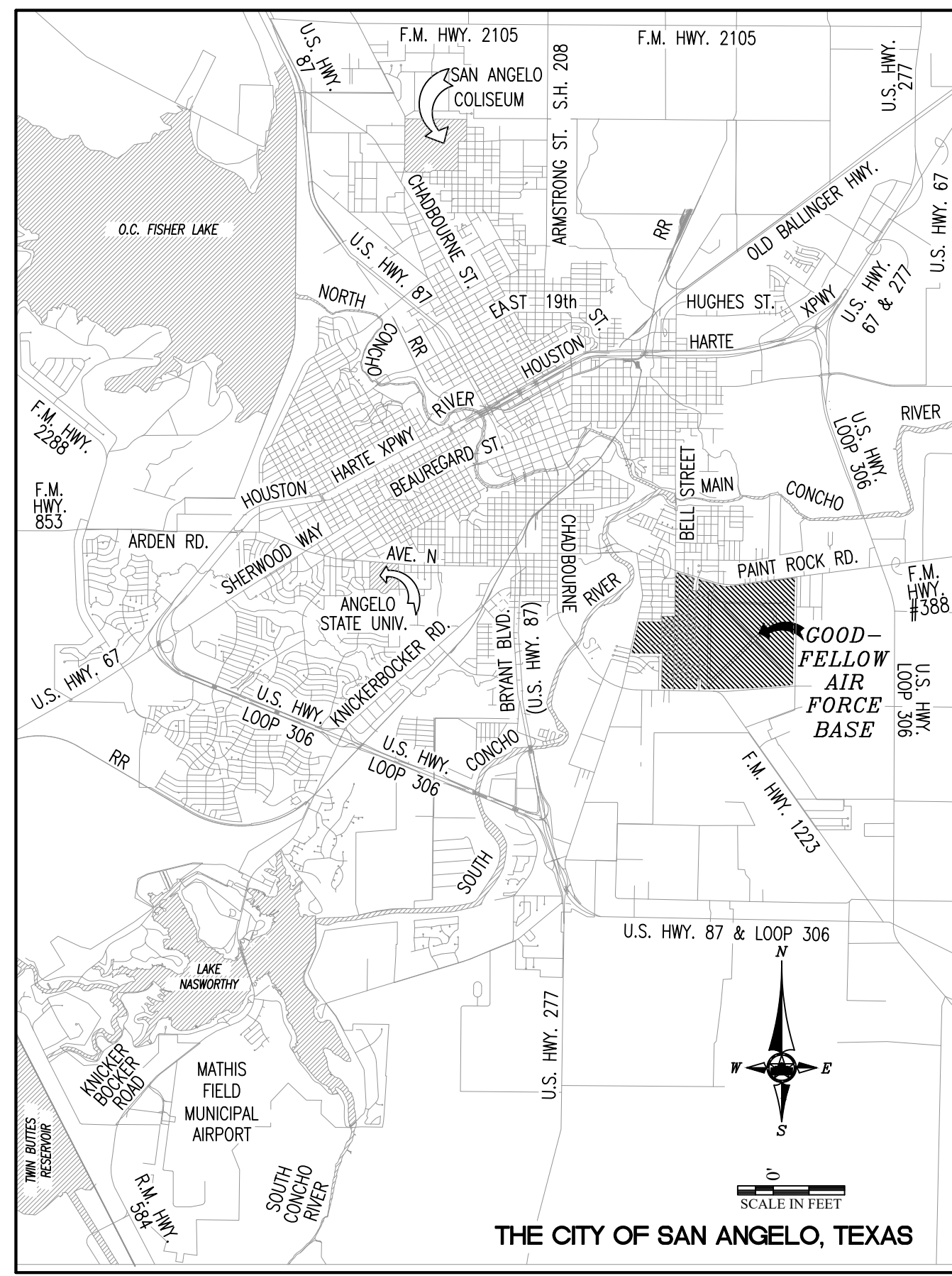

Designed by JH/RA/LLA	Drawn by JH/RA/LLA	Reviewed by RT/JH	Submitted by PC/ES
--------------------------	-----------------------	----------------------	-----------------------

FIRE STATION ADD/ALTER, B3321
PROJECT NO. 1039839
17th TRAINING WING
GOODFELLOW AIR FORCE BASE, TEXAS

PROJECT TITLE

Project Number:	1039839
SHEET TITLE	COVER SHEET
Date:	SEP 2023

SEQ.	SHEET	OF
01	G-001	50

TYPICAL ABBREVIATIONS [WHERE APPLICABLE]

ACCORD.	ACCORDANCE	DEMO	DEMOLITION
ACOUS. INSUL.	ACOUSTIC INSULATION	DET	DETAIL
ADDTN.	ADDITION	DIM	DIMENSION
ADJ.	ADJUSTABLE	DIST	DISTANCE
AFF	ABOVE FINISH FLOOR	DWG	DRAWING
ALUM.	ALUMINUM	EA	EACH
ATTEN.	ATTENUATING	ELEC	ELECTRIC(AL)
BITUM	BITUMINOUS	E.W.C.	ELECTRIC WATER COOLER
BLK	BLOCK	EXIST.	EXISTING
BLKG	BLOCKING	EXP. JT.	EXPANSION JOINT
BM	BENCH MARK	EQ	EQUAL
BOT	BOTTOM	E.W.	EACH WAY
CAB	CABINET	EXT.	EXTERIOR
CEM. BD.	CEMENTITIOUS BOARD	EXT. CAB.	EXTINGUISHER CABINET
CER TILE	CERAMIC TILE	F.D.	FLOOR DRAIN
CLG	CEILING	FEC	FIRE EXTINGUISHER CABINET
CONC.	CONCRETE	FIN	FINISH
CMU	CONC. MASONRY UNIT	FIN FLR	FINISH FLOOR
COL.	COLUMN	FLOUR.	FLOURESCENT
CONF.	CONFERENCE	FLR.	FLOOR
CONT.	CONTINUOUS	FLR. E.J.	FLOOR EXPANSION JOINT
COORD	COORDINATE	FURR'G	FURRING
CORR	CORRIDOR	GA.	GAUGE

GALV	GALVANIZED	PLY'WD	PLYWOOD
GFE	GOVERNMENT FURNISH EQUIPMENT	PLBG.	PLUMBING
GYP BD.	GYP SUM BOARD	PROJ. MNT.	PROJECTOR MOUNT
H.C.	HANDICAPPED	PROT.	PROTECTION
HDWD.	HARDWOOD	PSI	POUNDS PER SQUARE INCH
H.M.	HOLLOW METAL	RCP	REFLECTED CLG. PLAN
HORIZ.	HORIZONTAL	REF.	REFERENCE
INSUL	INSULATION	RESIL.	RESILIENT
LAV	LAVATORY	RM.	ROOM
MAINT	MAINTENANCE	SCHED.	SCHEDULE
MAX.	MAXIMUM	SCTN.	SECTION
MECH.	MECHANICAL	SCW	SOLID CORE WOOD
MFR.	MANUFACTURER	SPEC.	SPECIFICATION
MIN.	MINIMUM	S.S.	STAINLESS STEEL
MISC.	MISCELLANEOUS	STL.	STEEL
MPE	MECHANICAL-PLUMBING-ELECTRICAL	STRUCT.	STRUCTURE
MTD.	MOUNTED	SUSP. GRID	ELECTRICAL
MTL.	METAL	CLG. SYS.	SUSPENDED GRID CEILING SYSTEM
O.C.	ON CENTER	THK.	THICK
O.C.E.W.	ON CENTER EACH WAY	TYP.	TYPICAL
OPNG.	OPENING	TYP. MRKR./	TYPICAL MARKER/TACK
ORIG. BLDG.	ORIGINAL BUILDING	TACK BD.	BOARD
P	PLATE	UNC.	UNCASED

U.S.G.	UNITED STATES GYPSUM
V.C.T.	VINYL COMPOSITION TILE
VERT.	VERTICAL
V.W.C.	VINYL WALL COVERING
WD.	WOOD
WDW.	WINDOW
W/	WITH
W/MFR'S	WITH MANUFACTURER'S
W.W.F.	WELDED WIRE FABRIC
∅	DIAMETER

DRAWING INDEX	
Sheet Number	Sheet Title
GENERAL	
G-001	COVER SHEET
G-002	GENERAL INFORMATION 1
G-003	GENERAL INFORMATION 2
G-004	BID SCHEDULE
LIFE SAFETY	
LS-101	LIFE SAFETY PLAN
STRUCTURAL	
S-001	STRUCTURAL NOTES, SYMBOLS, & ABBREVIATIONS
S-101	FOUNDATION & FRAMING PLAN
S-501	DETAILS
S-502	DETAILS
CIVIL	
C-001	CIVIL SYMBOLS NOTES & ABBREVIATIONS
CU-101	EXISTING SITE UTILITIES
CG-101	SITE CONTOURS
CD-101	SITE DEMO
C-101	SITE NEW
C-501	SITE DETAILS
C-502	SITE DETAILS
ARCHITECTURAL	
AD-101	DEMO PLAN
A-101	FLOORPLAN NEW - OVERALL FLOORPLAN
A-102	FLOORPLAN NEW - NEW ADDITION
A-103	FLOORPLAN NEW - BID OPTIONS
A-201	REFLECTED CEILING PLAN
A-301	ROOF PLAN
A-401	BUILDING SECTIONS
A-501	EXTERIOR ELEVATIONS
A-601	ENLARGED PLANS
A-701	INTERIOR ELEVATIONS
A-801	FINISHES AND SCHEDULES
A-802	DOORS, WINDOWS, AND PARTITION TYPES
A-901	WALL SECTIONS AND DETAILS
A-1001	DETAILS
MECHANICAL	
M-001	MECHANICAL SYMBOLS NOTES & ABBREVIATIONS
MD-101	HVAC DEMO - BID OPTIONS
M-101	HVAC PLAN - NEW ADDITION
M-102	HVAC PLAN - BID OPTIONS
M-501	HVAC DETAILS
M-601	HVAC SCHEDULES
M-701	HVAC CONTROLS
ELECTRICAL	
E-001	ELECTRICAL SYMBOLS NOTES & ABBREVIATIONS
ED-101	ELECTRICAL DEMOLITION PLAN
E-101	ELECTRICAL POWER SUPPLY
E-201	LIGHTING PLAN
E-301	POWER PLAN
E-401	PA SYSTEM PLAN
E-601	EXISTING FIRE STATION PANELS
PLUMBING	
P-001	PLUMBING NOTES SYMBOLS & ABBREVIATIONS
P-101	SANITARY SEWER PLAN
P-102	DOMESTIC WATER PLAN
P-501	PLUMBING DETAILS 1
P-601	PLUMBING SCHEDULES
FIRE ALARM	
FA-001	FIRE PROTECTION PLAN, NOTES, & SYMBOLS

PRIVATIZED ELECTRICAL UTILITY SYSTEMS:

AEP TEXAS NORTH COMPANY IS THE UTILITY OWNER AND SOLE PROVIDER OF THE ELECTRICAL PRIMARY DISTRIBUTION UTILITY SYSTEM AT GOODFELLOW AIR FORCE BASE, TEXAS.

NEWLY PROVIDED SYSTEM INFRASTRUCTURE AND/OR MODIFICATIONS OF OR CONNECTIONS TO THE EXISTING SYSTEM INFRASTRUCTURE IDENTIFIED IN THE SPECIFICATIONS AND/OR DRAWINGS MUST BE COORDINATED WITH THE UTILITY OWNER PRIOR TO THE CONTRACT START DATE. TO CONNECT FACILITIES, THE CONSTRUCTION CONTRACTOR SHALL REQUEST THAT THE UTILITY OWNER PROVIDE THE REQUIRED CONNECTING FACILITIES, UP TO A POINT OF DEMARCATION WHICH INCLUDES ALL TERMINATIONS AT THE TRANSFORMER.

ALL WORK ON THE SYSTEM OR FACILITIES EXPECTED TO CONNECT TO THE SYSTEM SHALL COMPLY WITH THE UTILITY OWNER'S SPECIFICATIONS AND CONSTRUCTION STANDARDS. IN NO EVENT SHALL THE CONSTRUCTION CONTRACTOR CONNECT TO, OR OTHERWISE TOUCH THE UTILITY OWNER'S INFRASTRUCTURE WITHOUT THE UTILITY OWNER'S EXPRESS WRITTEN PERMISSION.

THE UTILITY OWNER: CONTACT VIA:
 AEP TEXAS NORTH COMPANY
 930 West 19th Street
 San Angelo, Texas 76903
 PHONE: 325-657-2800

ARCHITECT / ENGINEER RESPONSIBILITIES:

- SITE PLAN WITH ADJACENT STREETS OR LANDMARKS IDENTIFIED.
- BUILDING PLAN SHEETS WITH THE FOLLOWING INFORMATION:
 - LOCATION OF SERVICE ENTRANCE
 - REQUESTED TRANSFORMER LOCATION, IF A PREFERENCE IS KNOWN.
 - SQUARE FOOTAGE OF BUILDING SPACE WITH THE TYPE OF LOAD TO BE SERVED.
 - ELECTRICAL PANEL SCHEDULE
 - NUMBER AND SIZE OF SECONDARY CONDUCTORS TO BE TERMINATED AT THE TRANSFORMER
 - PROPOSED LOCATION OF OTHER UTILITY ROUTES AND ENTRANCES.
- LOAD DEMAND INFORMATION FROM EXISTING SIMILAR BUILDINGS.
- SCHEDULE OF WORK.

CONTRACTOR / BUILDER RESPONSIBILITIES:

- CONTACT NAMES AND NUMBERS UPON ARRIVAL AT THE SITE.
- LOCATION OF TRANSFORMER PAD.
- INSTALL SECONDARY CONDUITS INTO THE APPROPRIATE WELL LOCATION BEFORE PAD INSTALLATION. THIS INCLUDES ANY REQUIRED METERING CABLE CONDUITS.
- PROVIDE FINAL GRADE IN TRANSFORMER PAD AREA PRIOR TO PAD CONSTRUCTION.
- INSTALLATION OF ANY REQUIRED INSTRUMENT RATED METERING EQUIPMENT.
- PROVIDE SECONDARY CABLE TERMINALS.
- PRIMARY CONDUIT DITCH COMPACTION IF REQUIRED.
- ASPHALT AND/OR CONCRETE CUT AND REPAIR IF REQUIRED.
- LOCATION OF OTHER UTILITY LINES INSTALLED DURING THIS CONSTRUCTION.
- TEMPORARY POWER POLE, IF REQUIRED. LOCATION TO BE APPROVED BY AEP TEXAS. NOTE: ANY LINE EXTENSION REQUIRED FOR THE PURPOSE OF TEMPORARY SERVICE WILL REQUIRE A CIAC TO COVER THE COST OF INSTALLATION AND REMOVAL OF TEMPORARY FACILITIES AND ANY MATERIAL WHICH CANNOT BE REUSED.

AEP TEXAS RESPONSIBILITIES:

- SIZING AND INSTALLATION OF ALL PRIMARY CONDUCTORS INCLUDING DITCH AND CONDUIT.
- SIZING AND INSTALLATION OF DISTRIBUTION TRANSFORMERS.
- CONSTRUCTION OF TRANSFORMER PAD.
- INSTALLATION OF SECONDARY CABLE TERMINALS.

CONSTRUCTION NOTES:

- THE EDGE OF THE TRANSFORMER PAD SHALL NOT BE CLOSER THAN TWO FEET FROM A WALL, OR FIVE FEET FROM A DOOR OR WINDOW, OR TWENTY FEET FROM A STAIRWELL OR FIRE ESCAPE.
- TRANSFORMERS SHALL NOT BE COMPLETELY ENCLOSED BY WALLS, FENCES, OR LANDSCAPING WITHOUT VENTILATION WHICH IS APPROVED BY AEP TEXAS. THE ENTIRE WIDTH OF THE FRONT OF THE TRANSFORMER AND SECONDARY CABINET SHALL BE ACCESSIBLE. IF A FENCE IS INSTALLED, IT WILL HAVE SUFFICIENT GATES NECESSARY TO PROVIDE THIS ACCESS.
- TRANSFORMERS WILL BE LOCATED IN THE AREAS WITH ALL WEATHER ACCESS BY SERVICE TRUCKS. IN ADDITION, THERE WILL BE NO STRUCTURES CONSTRUCTED ABOVE TRANSFORMERS WHICH WOULD INHIBIT CRANE OPERATIONS.
- NO OTHER UTILITY LINES WILL BE INSTALLED WITHIN TWO FEET OF THE TRANSFORMER PAD.
- NO CUSTOMER EQUIPMENT, EXCEPT INSTRUMENT RATED METERING EQUIPMENT WHICH IS PLACED ON THE SECONDARY BUSHINGS, SHALL BE ATTACHED TO AEP TEXAS TRANSFORMERS; NOR WILL THERE BE ANY HOLES DRILLED INTO THE TRANSFORMER CABINET FOR CONDUITS, CONDUCTORS OR METERS.
- THE NUMBER AND SIZE OF THE SECONDARY CONDUCTORS WHICH ARE ALLOWED TO BE ATTACHED TO THE TRANSFORMER SECONDARY BUSHINGS WILL BE CONTROLLED BY AEP TEXAS. IF THE DESIGN REQUIRES MORE OR LARGER CONDUCTORS THAN ALLOWED FOR A PARTICULAR TRANSFORMER SIZE, AEP TEXAS WILL INSTALL A SECONDARY CABINET WITH BUS BARS ADJACENT TO THE TRANSFORMER. AEP TEXAS WILL SUPPLY AND INSTALL THE SECONDARY CONDUCTORS FROM THE TRANSFORMER TO THE SECONDARY CABINET. THE POINT OF INTERCONNECTION WILL BE THE BUS BARS WITHIN THE SECONDARY CABINET. THIS CABINET WILL REQUIRE A LARGER TRANSFORMER PAD.
- TRANSFORMERS LARGER THAN 1000 KVA WILL REQUIRE A LARGER PAD.
- TEMPORARY CONSTRUCTION POWER WILL BE SUPPLIED TO CUSTOMER SUPPLIED POWER POLES LOCATED WITHIN FIVE FEET OF AN EXISTING PAD MOUNTED TRANSFORMER OR WITHIN FIFTY FEET OF A PRIMARY POWER POLE.

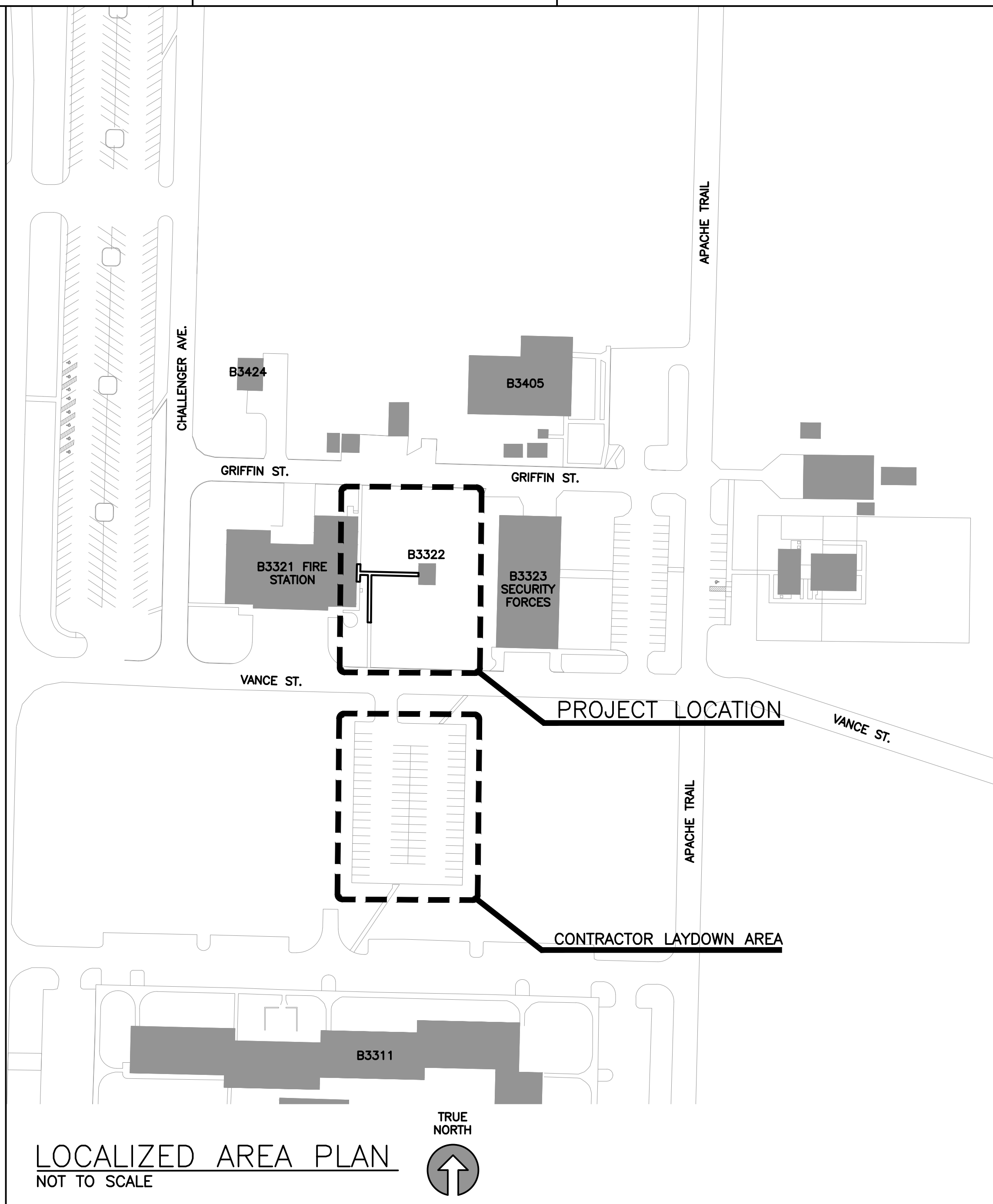

LOCALIZED AREA PLAN

NOT TO SCALE

LEGEND:

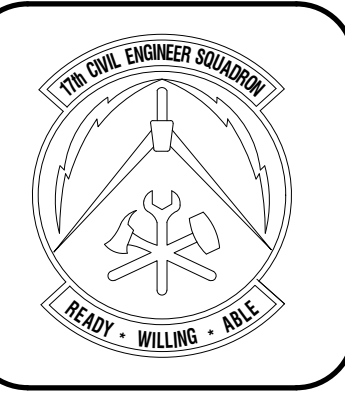
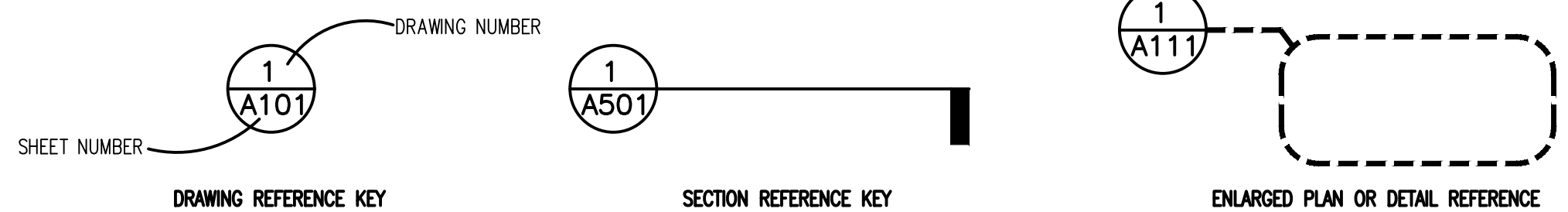

DESIGNED BY	JR/RA/LA
DRAWN BY	JR/RA/LA
REVIEWED BY	RTI/JH
SUBMITTED BY	PCES

PROJECT TITLE	FIRE STATION ADD/ALTER, B3321
PROJECT NO.	1039839
PROJECT LOCATION	17th TRAINING WING
PROJECT ADDRESS	GOODFELLOW AIR FORCE BASE, TEXAS

PROJECT NUMBER	1039839
SHEET TITLE	GENERAL INFORMATION 1
DATE	SEP 2023

SEQ.	SHEET	OF
02	G-002	50

A. GENERAL NOTES

- CONSTRUCTION ACCESS TO THE SITE SHALL BE THROUGH THE EXISTING SOUTH GATE LOCATED ON SOUTH CHADBOURNE STREET. ALL CONSTRUCTION TRAFFIC ENTERING THE BASE IS REQUIRED TO PASS THROUGH THE COMMERCIAL VEHICLE SEARCH AREA LOCATED TO THE EAST OF KEARNEY BOULEVARD. HOURS OF OPERATION ARE FROM 6:00 A.M. TO 2:00 P.M. MONDAY THROUGH FRIDAY, PHONE 325-654-1290.
- CONTRACTORS SHALL KEEP ALL PUBLIC ROADS AND STREETS CLEAN OF CONSTRUCTION DEBRIS, MUD, ETC. AT ALL TIMES. CONTRACTOR SHALL PROVIDE EQUIPMENT AND PERSONNEL TO CLEAN ANY STREETS AS REQUESTED BY THE CONTRACTING OFFICER. THE CONTRACTOR IS RESPONSIBLE FOR ALL REPAIRS TO STREETS, PARKING AREAS AND BASE OR GOVERNMENT PROPERTY DAMAGED FROM THEIR CONSTRUCTION ACTIVITIES.
- CONTRACTORS SHALL MAINTAIN A CONSTRUCTION SITE NEAT AND CLEAN OF DEBRIS AS DIRECTED BY CONTRACTING OFFICER. CONTRACTOR WASTE DUMPSTERS SHALL BE EMPTIED ON A REGULAR BASIS.
- THE CONTRACTOR AND CONTRACTOR PERSONNEL WILL NOT BE REQUIRED TO PARTICIPATE IN BASEWIDE ACTIVE SHOOTER DRILLS, EMERGENCY RESPONSE DRILLS, AND OTHER INCIDENT RESPONSE DRILLS. THE GOVERNMENT WILL COORDINATE THE OCCURRENCE OF THESE DRILLS WITH THE CONTRACTOR IN THE EVENT THAT DRILLS WILL AFFECT CONTRACTOR ACCESS TO GOODFELLOW AFB.

B. STAGING NOTES

- CONTRACTOR SHALL PROVIDE AND MAINTAIN A TEMPORARY CONSTRUCTION CHAIN LINK FENCE, 6 FEET HIGH, AROUND THE LIMITS OF WORK NOT INCLUDING THE CONSTRUCTION ACCESS ROAD. COORDINATE CHAIN AND PADLOCKS ON GATES WITH GOODFELLOW FIRE DEPARTMENT. EACH GATE SHALL BE NUMBERED FOR EMERGENCY ACCESS, SHALL HAVE ENTRY/EGRESS SIGNAGE AND AREA LIGHTING. CONTRACTORS SHALL MAINTAIN FIRE ACCESS THROUGH EACH INDIVIDUAL CONSTRUCTION SITE AT ALL TIMES.
- TRUCK WASHOUT AREA SHALL BE CONSTRUCTED, MAINTAINED AND CLEANED IN ACCORDANCE WITH TCEQ REGULATIONS. PROVIDE DETAILS AND MAINTENANCE PLAN AS PART OF THE STORMWATER POLLUTION PREVENTION PLAN. STORMWATER PERMITS ARE REQUIRED PRIOR TO THE START OF CONSTRUCTION.
- ALL CONTRACTORS SHALL STOCKPILE REQUIRED MATERIALS AND EQUIPMENT WITHIN LIMITS OF RESPECTIVE PROJECT AREAS OR STAGING AREA AS INDICATED ON THE DRAWINGS.
- CONTRACTOR SHALL CONNECT TO EXISTING OR NEW FIRE HYDRANTS FOR TEMPORARY CONSTRUCTION WATER. INSTALL QUICK DISCONNECT, BACK FLOW PREVENTER AND SHUT-OFF VALVE ON 2 1/2" HOSE CONNECTION ONLY. PRIOR TO MAKING ANY CONNECTIONS TO BASE WATER SYSTEMS, THE CONTRACTOR MUST NOTIFY AND COORDINATE WITH 17CES. A FIRE PLUG USAGE PERMIT IS REQUIRED AND USAGE SHALL BE METERED AT ALL TIMES.
- ALL TEMPORARY ELECTRIC POWER FACILITIES SHALL MEET OR EXCEED NESC AND NEC REQUIREMENTS AS APPLICABLE FOR PRIMARY AND SECONDARY FACILITIES.

C. ACCESS AND VEHICLE PARKING

- ACCESS TO THE PROJECT FOR ALL CONSTRUCTION PERSONNEL, VEHICLES AND EQUIPMENT IS ILLUSTRATED ON THE LOCALIZED AREA PLAN SHOWN ON SHEET G-002. ACCESS ROUTES MAY BE SUBJECT TO CHANGE BASED ON OPERATIONAL REQUIREMENTS. POTENTIAL SCHEDULE IMPACTS SHALL BE COORDINATED WITH 17CES.
- LOCATION OF ACCESS/ HAUL ROADS ARE AS INDICATED ON G-001 AND G-002.
- ALL HAUL ROADS SHALL BE MAINTAINED SUCH THAT UNOBSTRUCTED ACCESS WILL BE PROVIDED AT ALL TIMES FROM THE ROAD TO THE STAGING AREA AND FROM THE STAGING AREA TO THE WORK SITE AND FACILITATE GOVERNMENT ACCESS TO THE BASE AT ALL TIMES. THE MAINTENANCE OF HAUL ROADS SHALL BE THE RESPONSIBILITY OF THE CONTRACTOR AT NO ADDITIONAL COST TO THE GOVERNMENT. THE HAUL ROAD LOCATIONS SHALL BE AS INDICATED ON G-000 AND G-001.
- CONTRACTOR SHALL COORDINATE ACTIVITIES THROUGHOUT THE PROJECT IN A MANNER THAT ALLOWS EMERGENCY ACCESS TO ALL EXISTING ROADWAYS AT ALL TIMES WITHOUT DELAYS TO EMERGENCY VEHICLES RESPONSE TIME.
- ALL CONTRACTOR VEHICLES AND PERSONNEL MAY BE SEARCHED BY SECURITY FORCES WHEN ENTERING THE BASE AND MAY EXPERIENCE DELAYS. ALL PERSONNEL ENTERING GOODFELLOW A.F.B. MUST HAVE A VALID PHOTO ID PER BASE SECURITY REQUIREMENTS. ALL VEHICLES ENTERING THE BASE MUST HAVE CURRENT/ VALID REGISTRATION, CURRENT/ VALID INSURANCE AND CURRENT/ VALID DRIVERS LICENSE FOR THE OPERATOR. ALL DRIVERS MUST COMPLY WITH ALL GOODFELLOW AFB DRIVING REQUIREMENTS (SPEED LIMITS, SEATBELTS, ETC.) PERSONNEL ATTEMPTING TO GAIN ACCESS TO GOODFELLOW AFB NOT IN COMPLIANCE WITH BASE SECURITY REQUIREMENTS MAY BE REJECTED ACCESS TO THE BASE..
- WHEN NOT ENGAGED IN CONSTRUCTION ACTIVITIES, THE CONTRACTOR'S CONSTRUCTION EQUIPMENT AND VEHICLES SHALL BE PARKED WITHIN THE WORK AREA OR STAGING AREA.

D. COORDINATION AND COMMUNICATION DURING CONSTRUCTION

- PRIOR TO CONSTRUCTION, THE CONTRACTOR SHALL CORDON OFF THE WORK AREAS AND STREET CROSSINGS BY USING APPROVED BARRICADES.

E. TRAFFIC CONTROL

- ONLY RUBBER-TIRED VEHICLES SHALL BE ALLOWED ON EXISTING PAVEMENT THAT IS TO REMAIN.
- ANY DAMAGE TO ROADS AND PAVEMENT DUE TO CONSTRUCTION EQUIPMENT, CONSTRUCTION TRAFFIC OR CONSTRUCTION ACTIVITY SHALL BE REPAIRED TO THEIR ORIGINAL CONDITION BY THE CONTRACTOR AT HIS/ HER OWN EXPENSE.

F. EQUIPMENT AND STOCKPILE HEIGHT

- STOCKPILE ALL CONSTRUCTION MATERIALS WITHIN STAGING AREA. MAXIMUM HEIGHT 15.00' WITH 5:1 SIDE SLOPES. PROVIDE EROSION CONTROL PROTECTION AROUND THE STOCKPILE LIMITS. ANY MATERIALS THAT ARE TO BE STOCKPILED FOR USE FOR OTHER PROJECTS ON THE BASE SHALL BE COORDINATED WITH 17CES. ALL MATERIAL NOT REQUIRED SHALL BE HAULED OFF GOVERNMENT PROPERTY.

G. EXCAVATION AND TRENCHES

- OPEN TRENCHES AND EXCAVATIONS AT THE CONSTRUCTION SITE SHALL BE PROMINENTLY MARKED WITH ORANGE AND WHITE TYPE III BARRICADES AND WITH FLASHING TYPE A-LOW INTENSITY WARNING LIGHTS FROM DUSK TILL DAWN.

H. OTHER SAFETY REQUIREMENTS

- CONTRACTOR SHALL MAINTAIN SAFETY PRACTICES THAT CONFORM TO OCCUPATIONAL SAFETY AND HEALTH ADMINISTRATION (OSHA) REGULATIONS.
- CONTRACTOR SHALL MAINTAIN AT ALL TIMES ONE FIRE LANE FREE FROM OBSTRUCTION AND MAINTAIN ACCESS TO THE SITE AND ALL SURROUNDING ROADS AND STREETS.

I. CONTRACTOR SAFETY PLAN SUBMITTALS

- CONTRACTOR SHALL FURNISH A CONSTRUCTION SAFETY PLAN IN ACCORDANCE WITH THE SPECIFICATIONS WITH THE PROJECT SCHEDULE. THE SAFETY PLAN SHALL IDENTIFY THE FOLLOWING ITEMS:
 - PROPOSED ACCESS POINTS, STAGING AREA AND HAUL ROUTES.
 - TEMPORARY MARKINGS TO BE USED, IF ANY.
 - LOCATIONS AND TYPE OF BARRICADES OR OTHER TRAFFIC CONTROL DEVICES.
 - METHODS BY WHICH THE CONTRACTOR WILL COMMUNICATE WITH 17CES.

J. MAINTENANCE OF STORAGE AREA

- THE CONTRACTOR SHALL AT ALL TIMES KEEP THE CONSTRUCTION SITE, CONSTRUCTION TRAILER(S)/BUILDING(S), AND STORAGE AREA(S) IN A CLEAN, NEAT, WORKMAN LIKE CONDITION, FREE FROM ACCUMULATION OF WASTE, RUBBISH, WEEDS, OVERGROWN GRASS, OR CONSTRUCTION DEBRIS, TO THE SATISFACTION OF THE CONTRACTING OFFICER. ALL LOOSE OR LIGHT WEIGHT MATERIALS SHALL BE SECURED TO PREVENT BLOWING OR SCATTERING. THE BURNING OF TRASH OR CONSTRUCTION DEBRIS IS STRICTLY PROHIBITED ON GOODFELLOW AFB. PRIOR TO FINAL INSPECTION, THE CONTRACTOR SHALL REMOVE ALL CONSTRUCTION DEBRIS, TOOLS, EQUIPMENT, AND MATERIALS NOT THE PROPERTY OF THE GOVERNMENT. UPON COMPLETION OF THE WORK, THE CONTRACTOR SHALL LEAVE THE WORK SITE AND STORAGE AREA(S) IN A CLEAN, NEAT, AND WORKMANLIKE CONDITION SATISFACTORY TO THE CONTRACTING OFFICER. REFER TO STATEMENT OF WORK.
- THE CONTRACTOR SHALL KEEP FENCING IN A STATE OF GOOD REPAIR AND PROPER ALIGNMENT. GRASSED OR UNPAVED AREAS, WHICH ARE NOT ESTABLISHED ROADWAYS, WILL BE COVERED WITH A LAYER OF GRAVEL AS NECESSARY TO PREVENT RUTTING AND THE TRACKING OF MUD ONTO PAVED OR ESTABLISHED ROADWAYS. SHOULD THE CONTRACTOR ELECT TO TRAVERSE THEM WITH CONSTRUCTION EQUIPMENT OR OTHER VEHICLES; GRAVEL GRADATION WILL BE AT THE CONTRACTOR'S DISCRETION. MOW AND MAINTAIN GRASS LOCATED WITHIN THE BOUNDARIES OF THE CONSTRUCTION SITE FOR THE DURATION OF THE PROJECT. GRASS AND VEGETATION ALONG FENCES, BUILDINGS, UNDER TRAILERS, AND IN AREAS NOT ACCESSIBLE TO MOWERS WILL BE EDGED OR TRIMMED NEATLY.
- GRASS AND WEEDY VEGETATION WITHIN THE AREAS UTILIZED BY THE CONTRACTOR, INCLUDING WORK AREAS, ADMINISTRATIVE AREAS, AND STORAGE AREAS, SHALL BE KEPT MOWED TO CONTROL VEGETATIVE GROWTH. VEGETATION SHALL BE MOWED WHEN IT REACHES A HEIGHT OF 6 INCHES. MOWING SHALL BE TO A HEIGHT OF 3 INCHES. MOWING SHALL BE ACCOMPLISHED WITH A ROTARY MOWER THAT LEAVES THE CLIPPINGS EVENLY DISTRIBUTED ON THE SOIL SURFACE. MOWING SHALL BE ACCOMPLISHED DURING PERIODS AND IN SUCH MANNER THAT THE SOIL AND GRASS WILL NOT BE DAMAGED. TOWED OR SELF-PROPELLED RIDING MOWERS SHALL NOT BE OPERATED WITHIN 3 FEET OF TREES OR SHRUBS. AREAS ADJACENT TO TREES AND SHRUBS SHALL BE MOWED WITH HAND-PROPELLED MOWERS.
- EROSION CONTROL DEVICES SHALL BE USED FOR THE STAGING AREA AND ANY MATERIAL STOCK PILES WHEN NECESSARY TO CONTROL EROSION AND STORM WATER RUNOFF IN ACCORDANCE WITH FEDERAL, STATE, AND LOCAL REGULATIONS.
- AREAS NOT MOWED: GOVERNMENT MAY IMMEDIATELY AFTER NOTICE TO THE CONTRACTOR AND AT THE DISCRETION OF THE CONTRACTING OFFICER MOW THE CONTRACTOR'S AREAS AT ANY TIME THE VEGETATION HEIGHT EXCEEDS 6 INCHES.

K. WATERING

- THE CONTRACTOR SHALL COMPLY WITH THE CURRENT CITY OF SAN ANGELO, TEXAS WATER CONSERVATION AND DROUGHT CONTINGENCY PLAN FOR ALL ON BASE WATER USAGE.

PROJECT NOTES

- THESE PROJECT NOTES SHALL APPLY THROUGHOUT THE CONTENTS OF THESE CONSTRUCTION DOCUMENTS AND ALL WORK FOR THIS PROJECT.
- THE CONTRACTOR SHALL VERIFY ALL EXISTING AND NEW DIMENSIONS AND CONDITIONS PRIOR TO COMMENCEMENT OF ANY AND ALL WORK FOR THIS PROJECT.
- THE CONTRACTOR SHALL PROVIDE ALL MATERIALS, LABOR, TOOLS, EQUIPMENT, AND ASSOCIATED WORK REQUIRED TO COMPLETELY EXECUTE THE PROJECT.
- THE CONTRACTOR SHALL PROVIDE ALL WORK COMPLETE, IN TEH QUICKEST TIME PRACTICAL, AND IN A NEAT WORKMANLIKE MANNER.
- THE CONTRACTOR SHALL PROVIDE ITEMS OF WORK NOT SPECIFICALLY INDICATED, BUT OBVIOUSLY AND/OR NORMALLY REQUIRED TO COMPLETELY AND PROPERLY EXECUTE THE WORK.
- THE CONTRACTOR SHALL COMPLY WITH ALL LAWS GOVERNING SAFETY, SPECIFICALLY THE "OCCUPATIONAL SAFETY AND HEALTH" STANDARDS (OSHA)
- THE CONTRACTOR SHALL COMPLY WITH REQUIREMENTS OF THE FEDERAL "AMERICANS WITH DISABILITIES ACT" AND THE "TEXAS ACCESSIBILITIES STANDARDS/TEXAS "ELIMINATIONS OF ARCHITECTURAL BARRIERS ACT" [LATEST EDITIONS]
- THE CONTRACTOR SHALL BE RESPONSIBLE FOR PROTECTION OF THE EXISTING ON-SITE BUILDINGS AND OTHER INSTALLATIONS THAT ARE TO REMAIN INTACT DURING AND AFTER WORK FOR THIS PROJECT.
- THE CONTRACTOR SHALL TAKE ALL MEASURES NECESSARY TO PROTECT THE PROJECT DURING CONSTRUCTION, INCLUDING BUT NOT LIMITED TO, BRACING AND SHORING OF DEAD LOADS, CONSTRUCTION LOADS, AND WIND LOADS.
- THE CONTRACTOR SHALL PROVIDE AND MAINTAIN FIRE EXTINGUISHERS ON SITE DURING CONSTRUCTION FOR THIS PROJECT.
- THE CONTRACTOR SHALL PROVIDE AND MAINTAIN A CLEAN, SECURE, WEATHERTIGHT, TEMPORARY FIELD OFFICE WITH ALL REQUIRED SERVICES DURING THE COURSE OF THE PROJECT. THE FIELD OFFICE SHALL BE A PORTABLE FACILITY PLACED ON SITE AT A LOCATION MUTUALLY AGREEABLE TO BOTH CONTRACTOR AND CONTRACTING OFFICER OR CONTRACTING OFFICER REPRESENTATIVE.
- THE CONTRACTOR SHALL MAINTAIN A COMPLETE, CURRENT SET OF THE CONSTRUCTION DOCUMENTS AND DAILY PROJECT LOG IN THE FIELD OFFICE AT ALL TIMES. DAILY REPORTS INDICATING NUMBER OF EMPLOYEES WORKING, WORK PERFORMED, EQUIPMENT USED, AND PROGRESS PICTURES SHALL BE SUBMITTED VIA EMAIL TO THE CONTRACTING OFFICER OR CONTRACTING OFFICER REPRESENTATIVE ON A WEEKLY OR DAILY BASIS UNTIL PROJECT COMPLETION.
- THROUGHOUT THE ENTIRE COURSE OF THE WORK, THE CONTRACTOR SHALL MAINTAIN A QUALIFIED SUPERINTENDENT ON SITE AT ALL TIMES MONDAY-FRIDAY DURING DESIGNATED WORK TIMES. CONTRACTOR SHALL PROVIDE AN ASSIGNED ALTERNATE ON SITE SUPERINTENDENT DURING THE PRIMARY SUPERINTENDENTS ABSENCE. BOTH SHALL HAVE FULL AUTHORITY TO ACT ON BEHALF OF THE CONTRACTOR.
- THE CONTRACTOR SHALL COORDINATE ALL WORK FOR THIS PROJECT WITH WORK OF OTHER TRADES.
- THE CONTRACTOR SHALL PROVIDE AND PROPERLY MAINTAIN PORTABLE TOILET(S) ON SITE FOR USE BY CONTRACTOR EMPLOYEES OR SUBCONTRACTORS. USE OF EXISTING FIRE STATION RESTROOMS WILL NOT BE ALLOWED.
- THE CONTRACTOR SHALL BE RESPONSIBLE FOR THE REMOVAL OF ALL CONSTRUCTION DEBRIS FROM PROJECT SITE AND SHALL PROVIDE AND MAINTAIN DUMPSTERS, INCLUDING ALL ASSOCIATED DUMPING FEES, HAULING OF DEBRIS FROM SITE, AND REMOVAL FEES.
- THE CONTRACTOR SHALL KEEP THE PROJECT FACILITY AND SITE FREE OF ALL DEBRIS ON A DAILY BASIS AND PROVIDE FINAL CLEANUP IN ACCORDANCE WITH THE SPECIFICATIONS AND TO THE CONTRACTING OFFICER'S SATISFACTION.
- THE CONTRACTING OFFICER SHALL BE THE FINAL AUTHORITY IN MATTERS REGARDING INTERPRETATION OF THE INSTRUCTIONS AND INTENT OF THE CONSTRUCTION DOCUMENTS.
- IN THE EVENT OF DISCREPANCIES, SPECIFICATIONS SHALL TAKE PRECEDENT OVER THE DRAWINGS,
- UNLESS INDICATED OTHERWISE, ALL EXTERIOR AND INTERIOR FINISHES SHALL BE CODE COMPLIANT AND AS DIRECTED BY THE PROJECT MANAGER.
- THE CONTRACTOR SHALL PROVIDE THE CONTRACTING OFFICER OR CONTRACTING OFFICER REPRESENTATIVE WITH ALL MATERIAL AND/OR PRODUCT SAMPLES AND COLORS FOR PROPER SELECTION AND FINAL APPROVAL PRIOR TO INSTALLATION.
- THE CONTRACTOR SHALL PROVIDE SUBMITTALS FOR ALL PRODUCTS AND/OR MATERIALS LISTED IN THE SPECIFICATIONS FOR APPROVAL PRIOR TO INSTALLATION.
- ALL CHANGES, MODIFICATIONS, AND/OR ALTERATIONS TO THE WORK INCLUSIVE OF THESE CONTRACT DOCUMENTS SHALL REQUIRE THE STANDARD CHANGE ORDER PROCESS AND THE ISSUANCE OF A SIGNED CHANGE ORDER (AIA G701) PRIOR TO PERFORMANCE WORK FOR SAID CHANGES, MODIFICATIONS AND/OR ALTERATIONS.
- ALL PRODUCTS AND/OR MATERIALS SHALL NOT BE INSTALLED UNTIL APPROVED BY THE CONTRACTING OFFICER.
- ALL PRODUCTS AND/OR MATERIALS SHALL BE PROVIDED, STORED, AND INSTALLED PER THE RESPECTIVE MANUFACTURER'S RECOMMENDATIONS, MINIMUM.
- THE CONTRACTOR SHALL WARRANT ALL EQUIPMENT, MATERIALS, AND WORKMANSHIP FOR A PERIOD OF ONE (1) YEAR AFTER PROJECT COMPLETION. ANY MANUFACTURER AND/OR SPECIFIED WARRANTY THAT IS FOR PERIOD LONGER THAN THE ONE (1) YEAR WARRANTY SHALL BE SO WARRANTED.
- THE CONTRACTOR SHALL ENSURE THAT ALL EXTERIOR GRADES AT NEW CONSTRUCTION PROVIDE FOR POSITIVE DRAINAGE AWAY FROM THE BUILDING.
- ALL WELDERS SHALL BE CURRENTLY A.W.S. CERTIFIED AND WELDING SHALL COMPLY WITH CURRENT A.W.S. STANDARDS.
- GYPSUM WALL AND CEILING BOARDS SHALL BE TEXTURED ORANGE PEEL THROUGHOUT AND/OR WHERE REQUIRED.
- THE CONTRACTOR SHALL PROVIDE OWNER WITH A SINGLE "AS-BUILT" SET OF DRAWINGS COMPRISED OF RED-LINE MARKUPS OF ALL PROJECT ALTERATIONS AND/OR CHANGES.
- ALL COMPACTION FOR FILL SHALL BE 95% STANDARD PROCTOR DENSITY, MINIMUM.
- THE CONTRACTOR SHALL NOT SCALE DRAWINGS HEREIN.

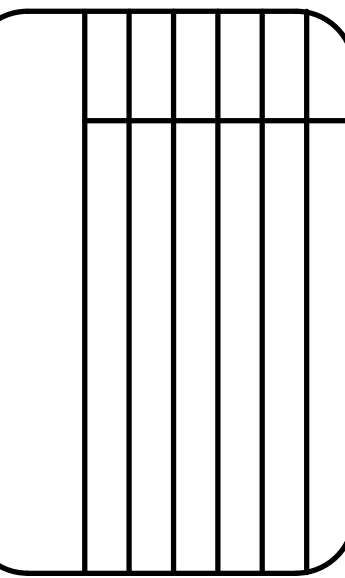
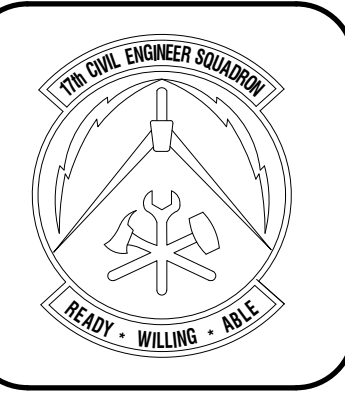

Designed by
JH/ML/A

Drawn by
JH/ML/A

Reviewed by
RTJ/AH

Submitted by
PCES

PROJECT TITLE

FIRE STATION ADD/ALTER, B3321

PROJECT NO. 1039839

17th TRAINING WING

GOODFELLOW AIR FORCE BASE, TEXAS

Project Number:
1039839

SHEET TITLE
GENERAL INFORMATION 2

Date:
SEP 2023

SEQ. SHEET OF

03 **G-003** 50

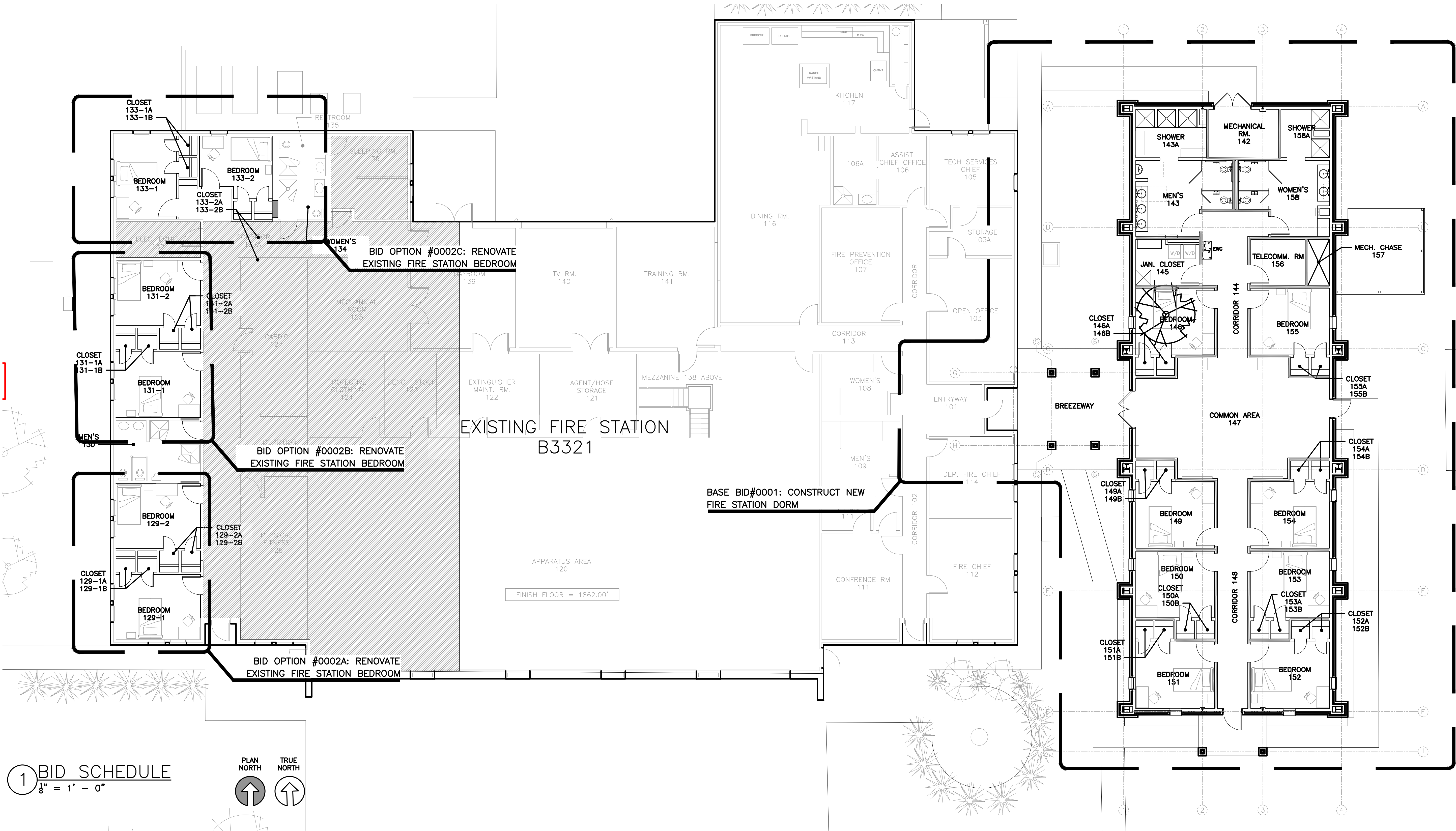
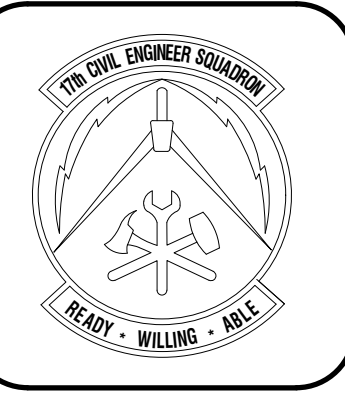

1 BID SCHEDULE
1/8" = 1' - 0"

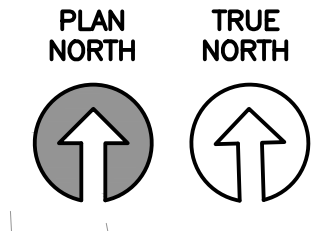

BID SCHEDULE

BASE BID #0001 - CONSTRUCT NEW FIRE STATION DORM:
CONSTRUCT NEW 8-BEDROOM DORMITORY COMPLETE WITH MEN/WOMEN'S RESTROOMS, TELECOMMUNICATIONS ROOM, JANITOR'S CLOSET, AND MECHANICAL ROOM.

BID OPTION #0002/#0003/#0004 - RENOVATE EXISTING FIRE STATION BEDROOMS:
DEMO EXISTING INTERIOR PARTITIONS, FIXTURES, HVAC AND FINISHES AND PROVIDE NEW.

--	--	--	--	--	--	--	--	--	--

Designed by JH/ML/A	Drawn by JH/ML/A	Reviewed by RT/JH	Submitted by PC/ES
------------------------	---------------------	----------------------	-----------------------

PROJECT TITLE
**FIRE STATION ADD/ALTER, B3321
PROJECT NO. 1039839
17th TRAINING WING
GOODFELLOW AIR FORCE BASE, TEXAS**

Project Number: 1039839
SHEET TITLE BID SCHEDULE
Date: SEP 2023

SEQ. 04	SHEET G-004	OF 50
------------	-----------------------	----------

FIRE STATION ADD/ALTER, B3321
LIFE SAFETY ANALYSIS

APPLICABLE CODES & STANDARDS

UNITED FACILITIES CRITERIA (UFC):

- UFC 1-200-01 GENERAL BUILDING REQUIREMENTS (2023)
- UFC 3-580-01 TELECOMMUNICATIONS INTERIOR INFRASTRUCTURE PLANNING AND DESIGN (2016)
- UFC 3-600-01 FIRE PROTECTION ENGINEERING FOR FACILITIES (2021)
- UFC 4-730-10 FIRE STATIONS (2021)

INTERNATIONAL BUILDING CODE IBC (2021)

INTERNATIONAL PLUMBING CODE IBC (2021)

NATIONAL FIRE PROTECTION ASSOCIATION (NFPA)

- NFPA 10 STANDARD FOR PORTABLE EXTINGUISHERS
- NFPA 13 INSTALLATION OF SPRINKLER SYSTEMS
- NFPA 14 INSTALLATION OF STANDPIPE AND HOSE SYSTEMS
- NFPA 70 NATIONAL ELECTRIC CODE (NEC) (2020)
- NFPA 72 NATIONAL FIRE ALARM CODE (2019)
- NFPA 90A STANDARD FOR INSTALLATION OF AIR-CONDITIONING AND VENTILATION SYSTEMS (2018)
- NFPA 101 LIFE SAFETY CODE (2018)
- ARCHITECTURAL BARRIERS ACT (ABA) 2015

IBC CHAPTER 3: OCCUPANCY TYPE

OCCUPANCY TYPE: R-2 DORMITORIES

NFPA CLASSIFICATION: RESIDENTIAL, CHAPTER 28: NEW HOTEL AND DORMITORIES

IBC CHAPTER 5: ALLOWABLE HEIGHTS/AREAS

ALLOWABLE BUILDING HEIGHT: PER TABLE 504.3

ALLOWED: 75' (SPRINKLERED)

ACTUAL: 15'-7"

ALLOWABLE NUMBER OF STORIES: PER TABLE 504.4

ALLOWED: 5 STORIES

ACTUAL: 1 STORY

ACTUAL BUILDING FOOTPRINT: 3,515 SQ.FT.

FIRE PROTECTION: FULLY SPRINKLERED IN ACCORDANCE WITH IBC 903.2.8

FIRE DETECTION: HEAT/SMOKE DETECTION, DUCT DETECTION, MANUAL PULL STATIONS, VISUAL STROBE AND AUDIBLE HORN ANNUNCIATION VIA ADDRESSABLE FIRE ALARM PANEL WITH POINT-TO-POINT DETECTION.

IBC CHAPTER 6: CONSTRUCTION TYPE

FIRE RESISTANCE REQUIREMENTS (TYPE 2B) CONSTRUCTION REQUIREMENTS: PER TABLE 601







- PRIMARY STRUCTURE: 0
- BEARING WALLS: 0
- NON BEARING WALLS: 0
- FLOOR CONSTRUCTION: 0
- ROOF CONSTRUCTION: 0

IBC CHAPTER 7: FIRE AND SMOKE RESISTANT FEATURES

FIRE PROTECTION AREAS: (PER NFPA 28.3.2.2.2)

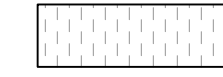
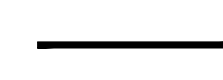
- BOILER AND FUEL FIRED HEATER ROOMS: 1 HOUR AND SPRINKLERS
- GUEST LAUNDRY: 1 HOUR OR SPRINKLERS
- STORAGE ROOMS: 1 HOUR OR SPRINKLERS
- FIRE BARRIERS (FB) - PER NFPA SEC. 8.3
- SMOKE PARTITIONS - PER NFPA SEC. 8.3

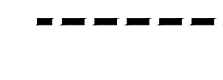
LEGEND

-  RESIDENTIAL OCCUPANCY (200 SQFT / OCC.)
-  ASSEMBLY OCCUPANCY (15 SQFT. / OCC.)
-  STORAGE / MECH. ROOM OCCUPANCY (500 SQFT. / OCC.)
-  1/2 HOUR RATED FIRE PARTITION
-  1 HOUR RATED FIRE PARTITION
-  SMOKE PARTITION
-  RECESSED FIRE EXTINGUISHER AND CABINET PER NFPA 10. BRACKET AND CABINET SHALL ACCOMMODATE 10LB A/B/C CHEMICAL TYPES. CABINETS TO HAVE FLAT PARTIAL GLASS FRONT WITH HINGED LATCHING DOOR. MOUNT PER NFPA 10 REQ'S

IBC CHAPTER 7 CONT'D:

OPENING PROTECTION

- FIRE BARRIERS - PER NFPA SEC. 8.6
- SMOKE PARTITIONS - PER NFPA SEC 8.6
- PROTECTION OF VERTICAL OPENINGS PER NFPA 8.6

DOOR RATINGS:

- 1 HOUR FIRE BARRIERS: 45 MINUTE DOOR
- SMOKE PARTITION: NO FIRE RATING REQUIRED
- FIRE DOORS: PROVIDE SELF OR AUTOMATIC CLOSING FIRE DOORS WITH POSITIVE LATCHING HARDWARE PER NFPA 8.3.3.3
- SMOKE PARTITIONS: PROVIDE SELF OR AUTOMATIC CLOSING FIRE DOORS WITH POSITIVE LATCHING HARDWARE. NO FIRE RATING REQUIRED. LOULVRES ARE NOT PERMITTED.
- DOORS OPENING ONTO EXIT ACCESS CORRIDORS SHALL HAVE NOT LESS THAN 20-MINUTE FIRE PROTECTION RATING IN ACCORDANCE WITH NFPA 8.3 (PER NFPA 78.3.6.7)
- DOORS THAT OPEN ONTO EXIST ACCESS CORRIDORS SHALL BE SELF-CLOSING AND SELF-LATCHING PER NFPA 78.3.6.7.2

HVAC:

FIRE DAMPERS SHALL BE PROVIDED IN ALL AIR TRANSFER OPENINGS IN PARTITIONS THAT ARE REQUIRED TO HAVE A FIRE RESISTANCE RATING

CORRIDORS:

IN BUILDINGS PROTECTED BY AN APPROVED AUTOMATIC SPRINKLER SYSTEM, CORRIDORS SHALL HAVE 1/2 FIRE RESISTANCE RATING PER NFPA 78.3.6.1.2

IBC CHAPTER 10: MEANS OF EGRESS

OCCUPANT LOAD FACTOR:

ACCESSORY STORAGE AREAS, MECH. EQUIPMENT ROOMS: 500 (PER NFPA 101 TABLE 7.3.1.2)

331.91 SQFT./ (500) = .66 OCCUPANTS

ASSEMBLY: 15 NET (PER NFPA 101 TABLE 7.3.1.2)

964.62 SQFT. / (15) = 64.31

DORMITORIES : 200 (PER NFPA 101 TABLE 7.3.1.2)

2,218.47 SQFT. / (200) = 11.1 OCCUPANTS

CALCULATED OCCUPANT LOAD: 76.07 (77) * .2 OCC.

EGRESS WIDTH REQUIREMENTS: 15.4"

ACTUAL PROVIDED: 144"

NUMBER OF EGRESS EXITS (NOT INCLUDING PRIMARY/SECONDARY MEANS OF ESCAPE REQUIRED BY NFPA 28.2.1.2)

MINIMUM NUMBER OF EXITS: 2

ACTUAL EXITS PROVIDED: 3

MAXIMUM TRAVEL DISTANCES TO EXITS (PER NFPA 28.2.6)

GUEST ROOM TO CORRIDOR DOOR MAXIMUM: 125' (NFPA 28.2.6.2)

CORRIDOR DOOR TO EXIT: 200' (NFPA 28.2.6.3.2)

MAXIMUM COMMON TRAVEL PATHS (PER NFPA 28.2.5.4): 50'

DEAD END CORRIDOR MAX (PER NFPA 28.2.5.6): 50'

IBC CHAPTER 29: PLUMBING SYSTEMS

RESIDENTIAL OCCUPANCY: DORMITORIES

11.76 OCC (12) 6 MALE / 6 FEMALE

- WATER CLOSETS: 1 PER 10 (.6 MALE AND FEMALE)
- LAVATORIES: 1 PER 10 (.6 MALE AND FEMALE)
- SHOWERS: 1 PER 8 (.75 MALE AND FEMALE)
- DRINKING FOUNTAIN: 1 PER 100 (.06 REQ'D)
- 1 SERVICE SINK

ASSEMBLY OCCUPANCY: AUDITORIUMS WITHOUT PERMANENT SEATING

64.31 (65 OCC.) 32.5 MALE / 32.5 FEMALE

- WATER CLOSETS: 1 PER 125 MALE , 1 PER 65 FEMALE (.26 MALE / .5 FEMALE)
- LAVATORIES: 1 PER 200 (.325 REQ'D)
- SHOWERS: N/A
- DRINKING FOUNTAIN: 1 PER 500 (.13 REQ'D)
- 1 SERVICE SINK

TOTAL FIXTURE REQUIREMENTS

- MALE:
- WATER CLOSETS: .86 REQ'D / 2 PROVIDED (+ 1 URINAL)
- LAVATORIES: .925 REQ'D / 3 PROVIDED
- SHOWERS: .75 REQ'D / 3 PROVIDED

- FEMALE:
- WATER CLOSETS: 1.1 REQ'D / 2 PROVIDED
- LAVATORIES: .925 REQ'D / 2 PROVIDED
- SHOWERS: .75 REQ'D / 2 PROVIDED

- DRINKING FOUNTAIN: .19 REQ'D / 2 PROVIDED
- SERVICE SINK: 1 REQ'D / 1 PROVIDED

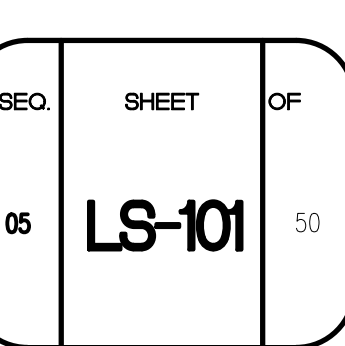
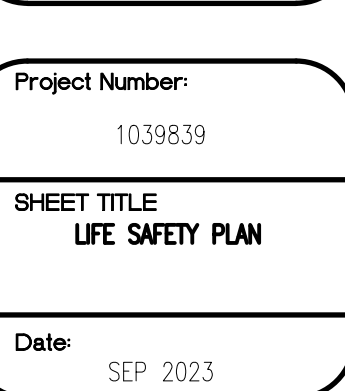
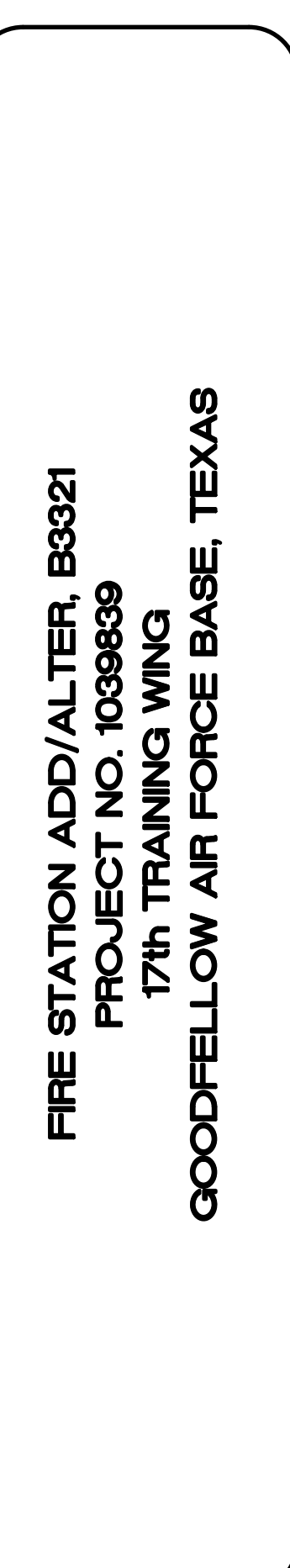
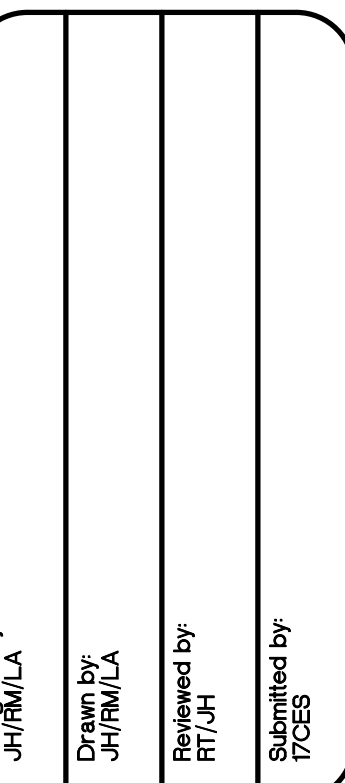
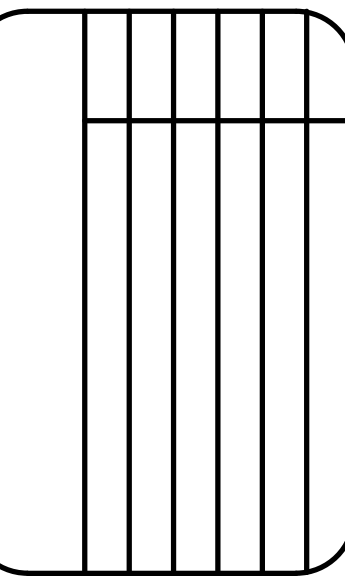
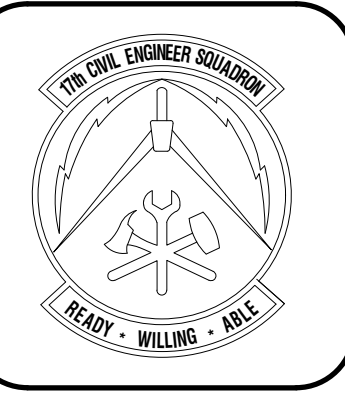
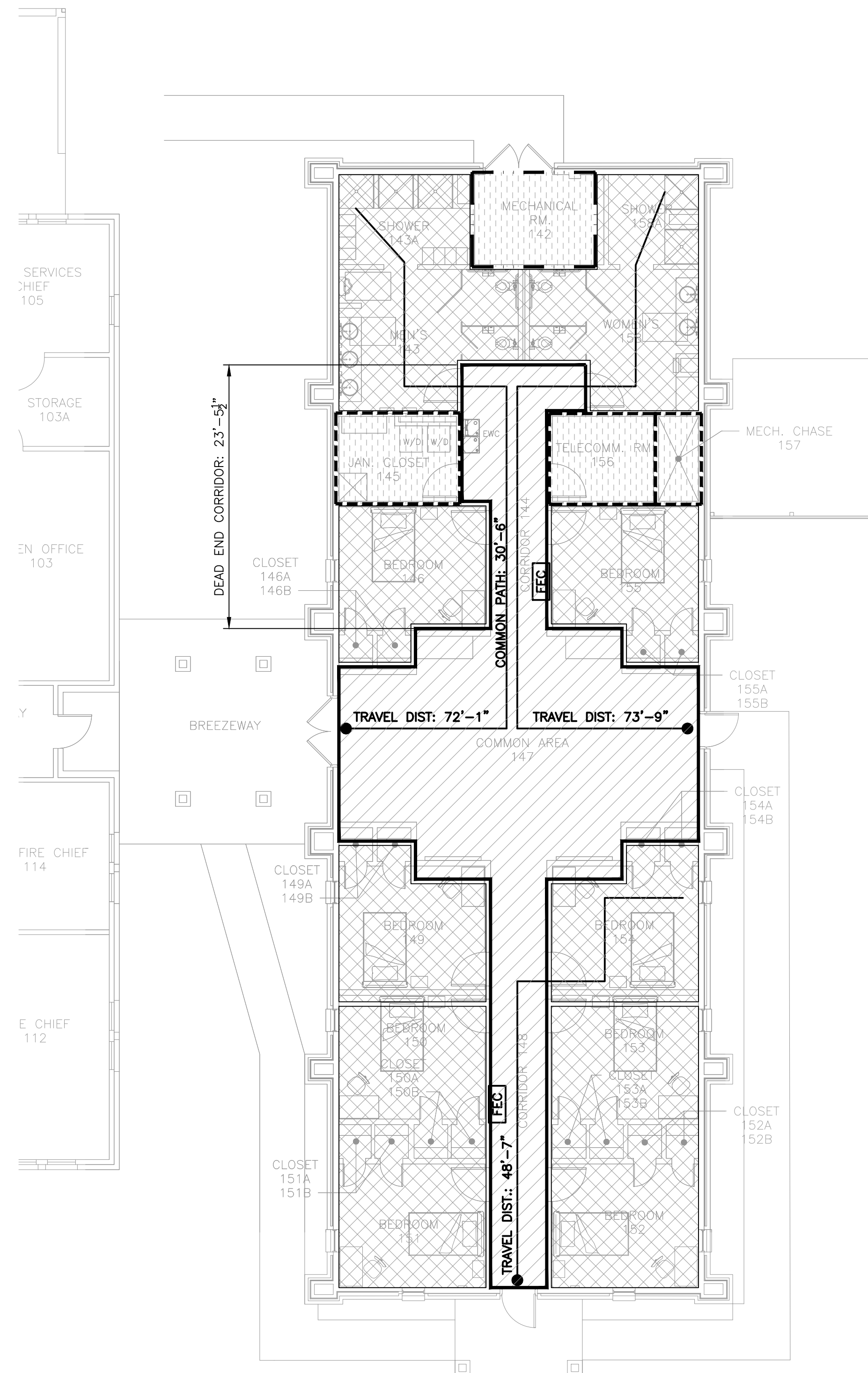

FIRE STATION ADD/ALTER, B3321
PROJECT NO. 1039839
17th TRAINING WING
GOODFELLOW AIR FORCE BASE, TEXAS

PROJECT TITLE

Project Number:
1039839

SHEET TITLE
LIFE SAFETY PLAN

Date:
SEP 2023

SEQ. SHEET OF
05 LS-101 50

GENERAL NOTES:

BUILDING CODES:

ALL STRUCTURAL FRAMING SYSTEMS PROVIDED BY THE CONTRACTOR SHALL BE DESIGNED IN GENERAL ACCORDANCE WITH THE FOLLOWING CODE REFERENCES:

- 1.UNIFIED FACILITIES CRITERIA (UFC) 1-200-01 GENERAL BUILDING REQUIREMENTS WITH CHANGE 1.
- 2.UNIFIED FACILITIES CRITERIA (UFC) 1-301-01 STRUCTURAL ENGINEERING, WITH CHANGE 1 REVISED.
- 3.INTERNATIONAL BUILDING CODE (IBC), 2012.
- 4.AMERICAN SOCIETY OF CIVIL ENGINEERS (ASCE) 7-10, MINIMUM DESIGN LOADS FOR BUILDINGS AND OTHER STRUCTURES.
- 5.AMERICAN INSTITUTE OF STEEL CONSTRUCTION SPECIFICATION (AISC) 360-10.
- 6.STEEL JOIST INSTITUTE (SJI) SPECIFICATIONS AND LOAD TABLES, 75 YEAR STEEL JOIST MANUAL.

DIVISION 1 – GENERAL REQUIREMENTS

CONTRACTOR SHALL PROVIDE NECESSARY EQUIPMENT, MATERIALS, AND LABOR REQUIRED TO PROVIDE NEW REINFORCED CONCRETE FOUNDATIONS AND SLABS, NEW PRE-ENGINEERED (PEB) METAL BUILDING, AND CONNECTED METAL CANOPIES AND BREEZEWAYS AS INDICATED IN THE FOLLOWING DRAWINGS.

THE CONTRACTOR SHALL BE RESPONSIBLE FOR REMOVING EXISTING VEGETATION AND TOPSOIL TO A DEPTH OF 30" BELOW GRADE. THE CONTRACTOR SHALL GRADE AND COMPACT THE SUB-BASE IN PREPARATION FOR NEW CONCRETE PADS AND SLABS AS INDICATED. LIFTS SHALL BE COMPACTED IN 6" BASE MATERIAL LIFTS AS SPECIFIED AND COMPACTED TO A MINIMUM 95% PROCTOR DENSITY UNLESS NOTED OTHERWISE.

THE CONTRACTOR SHALL PROVIDE ALL TESTING REPORTS FROM A CERTIFIED GEOTECHNICAL ENGINEER AS SPECIFIED.

CONTRACT DOCUMENTS INCLUDE, BUT ARE NOT LIMITED TO, THE STRUCTURAL DOCUMENTS (DRAWINGS AND SPECIFICATIONS), BUT DO NOT INCLUDE SHOP DRAWINGS, VENDOR DRAWINGS, OR MATERIAL PREPARED AND SUBMITTED BY THE CONTRACTOR. THE NOTES PRESENTED HEREIN ARE NOT INTENDED TO REPLACE THE SPECIFICATIONS. SEE THE SPECIFICATIONS FOR REQUIREMENTS IN ADDITION TO THE GENERAL NOTES.

REFERENCE TO STANDARD SPECIFICATIONS OF ANY TECHNICAL SOCIETY, ORGANIZATION OR ASSOCIATION OR TO CODES OF LOCAL OR STATE AUTHORITIES, SHALL MEAN THE LATEST STANDARD, CODE, SPECIFICATION OR TENTATIVE SPECIFICATION ADOPTED AT THE DATE OF TAKING BIDS, UNLESS SPECIFICALLY STATED OTHERWISE.

CONTRACT DOCUMENTS SHALL GOVERN IN THE EVENT OF A CONFLICT WITH THE CODE OF PRACTICE OR SPECIFICATIONS OF AISC, ASTM, AWC, SJI, AF&PA OR OTHER STANDARDS. WHERE A CONFLICT OCCURS WITHIN THE CONTRACT DOCUMENTS, THE MORE STRINGENT REQUIREMENT SHALL GOVERN.

CONTRACTOR HAS SOLE RESPONSIBILITY FOR MEANS, METHODS, SAFETY, TECHNIQUES, SEQUENCES, AND PROCEDURES OF CONSTRUCTION.

CONTRACTOR SHALL COORDINATE THE RELOCATION OF UTILITIES, IF REQUIRED BY THE REPAIRS. THE CONTRACTOR SHALL FOLLOW THE APPLICABLE CODES AND INDUSTRY STANDARDS WHEN MOVING EXISTING ELECTRICAL, MECHANICAL, COMMUNICATIONS, PLUMBING, WATER, AND SPRINKLER LINES, ETC. AS REQUIRED FOR THE PERFORMANCE OF THE STRUCTURAL REPAIRS.

THE CONTRACTOR SHALL HAVE ALL TEMPORARY SHORING DESIGNED AND CERTIFIED BY A QUALIFIED PROFESSIONAL ENGINEER LICENSED IN THE STATE OF TEXAS AS PART OF HIS WORK. THE CONTRACTOR SHALL SUBMIT ONE COPY OF THE ALL CERTIFIED TEMPORARY SHORING DOCUMENTS FOR REVIEW AND RECORD PURPOSES. DESIGN DOCUMENTS SHALL INCLUDE BUT NOT LIMITED TO: PLANS, SECTIONS, DETAILS, AND STRUCTURAL CALCULATIONS.

WORK SPECIFIED HEREIN SHALL BE INSPECTED IN ACCORDANCE WITH THE APPLICABLE BUILDING CODE, LOCAL ORDINANCES, AND THE CONTRACT DOCUMENTS. THE CONTRACTOR SHALL COORDINATE REQUIRED INSPECTIONS WITH THE GOVERNMENT'S INSPECTOR(S).

THE CONTRACTOR SHALL TAKE NECESSARY STEPS TO MINIMIZE INTERFERENCE WITH THE OPERATIONS AND BASE MISSION. PRIOR TO COMMENCING WORK, THE CONTRACTOR SHALL SUBMIT A DETAILED, WRITTEN WORK PLAN TO THE CONTRACTING OFFICER FOR REVIEW AND APPROVAL.

WHERE APPLICABLE THE CONTRACTOR SHALL COORDINATE ALL WORK ON ROOFS WITH THE CONTRACTING OFFICER SO THAT THE ROOF WARRANTIES ARE NOT VOIDED. THE CONTRACTOR SHALL PROPERLY REINSTALL OR REPLACE ANY ROOF OR FACADE COMPONENTS THAT WERE REMOVED OR DAMAGED DURING THE COURSE OF THE WORK PRIOR TO DEPARTURE FROM THE WORK SITE EACH DAY. ANY ROOF OR FACADE COMPONENTS THAT ARE REINSTALLED OR REPLACED SHALL BE WATER TIGHT. ALL REPAIRS SHALL BE APPROVED BY THE CONTRACTING OFFICIAL PRIOR TO THE COMMENCEMENT OF REPAIR ACTIVITIES.

WHERE SUSPECT BUILDING MATERIALS ARE ENCOUNTERED DURING SELECTIVE DEMOLITION OR REPAIRS OPERATIONS, THE CONTRACTOR SHALL IMMEDIATELY NOTIFY THE CONTRACTING OFFICER PRIOR TO PERFORMING ANY SAMPLING, TESTING, ABATEMENT, HANDLING, AND DISPOSAL OF ANY SUSPECT BUILDING MATERIAL(S) AND SHALL ADHERE TO THE STANDARDS, PRACTICES AND PROTOCOLS OF BASE COMMAND.

DIVISION 2 – SITE WORK

THE CONTRACTOR SHALL BE RESPONSIBLE FOR LOCATING ALL BURIED UTILITIES IN THE CONSTRUCTION AREA PRIOR TO BEGINNING WORK.

THE CONTRACTOR SHALL BE RESPONSIBLE FOR THE STORAGE, HAULING AND DISPOSAL OF ALL ITEMS SPECIFIED IN THE CONSTRUCTION DOCUMENT TO BE SELECTIVE DEMOLISHED.

THE CONTRACTOR SHALL BE RESPONSIBLE FOR THE INSTALLATION OF AND DESIGN OF THE SLAB ON GRADE FOUNDATION AND CONCRETE PIERS FOR PEB COLUMNS. THE CONTRACTOR SHALL SUBMIT DESIGN CALCULATIONS AND SHOP DRAWINGS SIGNED AND SEALED BY A REGISTERED ENGINEER IN THE STATE OF TEXAS TO THE CONTRACTING OFFICIAL PRIOR TO INSTALLATION.

DIVISION 3 – CONCRETE

ALL CONCRETE SHALL HAVE A MINIMUM 28 DAY COMPRESSIVE STRENGTH (f'c) OF 3,000 PSI.

ALL CONCRETE SHALL BE AIR ENTRAINED AND SHALL HAVE AN ENTRAINED AIR CONTENT RANGING BETWEEN 5 TO 7 PERCENT.

ALL CONCRETE REINFORCING STEEL SHALL BE ASTM A615 GRADE 60.

FOR HOT WEATHER CONCRETE, THE CONTRACTOR SHALL ADHERE TO THE REQUIREMENTS OF ACI 305.

FOR COLD WEATHER CONCRETE, THE CONTRACTOR SHALL ADHERE TO THE REQUIREMENTS OF ACI 306.

THE CONTRACTOR SHALL BE SUBMIT ALL CONCRETE MIX DESIGNS SHOP DRAWINGS TO THE CONTRACTING OFFICIAL FOR APPROVAL PRIOR TO BEGINNING WORK.

THE CONTRACTOR SHALL SUBMIT ALL CONCRETE SHOP DRAWINGS PRIOR TO CASTING CONCRETE.

THE CONTRACTOR SHALL BE RESPONSIBLE FOR THE DESIGN OF ALL CONCRETE FORM WORKS TO BE USED ON THIS PROJECT. THE CONTRACTOR SHALL SUBMIT ALL FORM WORK CALCULATIONS AND SHOP DRAWINGS TO THE CONTRACTING OFFICIAL PRIOR TO BEGINNING CONCRETE WORK. ALL FORM WORK CALCULATIONS AND SHOP DRAWINGS SHALL BE DESIGNED, SIGNED AND SEALED BY A REGISTERED ENGINEER IN THE STATE OF TEXAS.

DIVISION 4 – MASONRY

PROVIDE BRICK WAINSCOT AND STUCCO EXTERIOR WALL FINISH AS INDICATED AND AS SPECIFIED.

NEW BRICK VENEER TO MATCH EXISTING FIRE STATION FINISH AS MUCH AS POSSIBLE. CONTRACTOR SHALL SUBMIT SAMPLES OF BRICK TO THE GOVERNMENT FOR APPROVAL PRIOR TO INSTALLATION.

DIVISION 5 – STRUCTURAL STEEL

THE CONTRACTOR SHALL FIELD VERIFY ALL QUANTITIES AND RELEVANT DIMENSIONS OF STRUCTURAL STEEL AND MISCELLANEOUS STEEL MEMBERS USED IN THIS PROJECT PRIOR TO FABRICATION.

STEEL ANGLES SHALL MEET THE REQUIREMENTS OF ASTM A 36 AND SHALL BE PAINTED. SURFACES SHALL BE PREPARED IN ACCORDANCE WITH STEEL STRUCTURES PAINTING COUNCIL SPECIFICATION SSPC-SP7.

ALL STEEL SHALL BE DETAILED, FABRICATED, AND ERECTED IN ACCORDANCE WITH THE AISC MANUAL, AISC SPECIFICATION, AND AISC CODE OF STANDARD PRACTICE.

BOLTS, NUTS, AND WASHERS SHALL CONFORM TO THE REQUIREMENTS OF ASTM A 325. STRUCTURAL BOLTS SHALL BE 3/4 INCH DIAMETER MINIMUM.

ALL CHEMICAL EPOXY ANCHORS SHALL BE HILTI HIT-HY 150 ADHESIVE ANCHORING SYSTEM OR APPROVED EQUIVALENT. ANCHORS SHALL CONSIST OF 3/4" DIAMETER HILTI HAS RODS WITH A MINIMUM EMBEDMENT OF 6". IN THE EVENT THAT DAMAGE TO THE EXISTING CONCRETE WALL IS FOUND IN THE SPECIFIED CONNECTION AREA, THE CONTRACTING OFFICER SHALL BE IMMEDIATELY NOTIFIED AND ADHESION ANCHORS SHALL NOT BE INSTALLED UNTIL SUCH A TIME AS THE CONCRETE WALLS CAN BE EVALUATED.

EXTERIOR BREEZEWAY AND CANOPY ARE TO BE COMPRISED OF HOLLOW STRUCTURAL STEEL (HSS) MEMBERS UNLESS NOTED OTHERWISE. ALL EXPOSED MEMBERS WILL BE MED. BRONZE FINISH UNLESS NOTED OTHERWISE.

DIVISION 6 – WOOD AND PLASTIC

UNLESS STATED OTHERWISE, WOOD CONSTRUCTION SHALL BE DETAILED, FABRICATED, AND INSTALLED IN ACCORDANCE WITH THE APPLICABLE SECTIONS OF THE 2012 EDITION OF THE NATIONAL DESIGN SPECIFICATION (NDS) FOR WOOD CONSTRUCTION AS PUBLISHED BY THE AMERICAN FOREST AND PAPER ASSOCIATION (AF&PA) AND THE AMERICAN WOOD COUNCIL (AWC).

THE CONTRACTOR SHALL FIELD VERIFY DIMENSIONS PRIOR TO FABRICATION OF WOOD STRUCTURAL SHORING.

UNLESS OTHERWISE SPECIFIED, EACH PIECE OF LUMBER SHALL BEAR GRADE MARKS, STAMPS, OR OTHER IDENTIFYING MARKING INDICATING THE GRADES OF MATERIAL AND RULES OR STANDARDS UNDER WHICH PRODUCED.

MATERIAL FOR CRIBBING AND SHORING BEAMS SHALL BE SOUTHERN PINE No. 2 AND SHALL HAVE THE MINIMUM PROPERTIES LISTED BELOW. ALL LUMBER SHALL HAVE A MOISTURE CONTENT NOT EXCEEDING 19 PERCENT.

- FB = 1,050 PSI
- FT = 650 PSI
- FV = 175 PSI
- FC (PERP) = 565 PSI
- FC = 1,100 PSI
- E = 1,400,000 PSI

TEMPORARY SHORING

SCREW JACKS CAPABLE OF RESISTING A MINIMUM LOAD OF 1,300 LBS SHALL BE INSTALLED ON TIMBER CRIBBING. EACH JACK SHALL BE TIGHTENED UNTIL SHORING BEAM IS FULLY ENGAGED AGAINST THE BOTTOM OF THE EXISTING METAL FLOOR DECKING.

JACKS SHALL BE PERIODICALLY MONITORED AT LEAST ONCE A MONTH OR AFTER EACH SIGNIFICANT WEATHER EVENT. EACH JACK SHALL BE CHECKED TO VERIFY THAT IT IS ADEQUATELY TIGHT AND FULLY ENGAGED. WHERE JACKS ARE FOUND TO BE LOOSE, JACKS SHALL BE RE-TIGHTENED.

CRIBBING SHALL CONSIST OF 6X6 TIMBERS PLACE IN TWO LAYERS PERPENDICULAR TO EACH OTHER.

THE CONTRACTOR SHALL EXCAVATE THE TOP LAYER OF SOIL TO STIFF, DRY MATERIAL PRIOR TO THE INSTALLATION OF TIMBER CRIBBING. PROVISIONS SHALL BE MADE TO KEEP THE SHORING AREA AS DRY AS POSSIBLE TO AVOID IN ADVERTENT CRIBBING SETTLEMENT DUE TO THE SOFTENING OF THE BASE MATERIALS DUE TO EXCESSIVE MOISTURE EXPOSURE. TIMBER CRIBBING SHALL NOT BE PLACED ON LOOSE OR WET SOIL.



--	--	--	--	--	--	--	--

Designed by JH/RL/A	Drawn by JH/RL/A	Reviewed by RT/JH	Submitted by PC/BS
------------------------	---------------------	----------------------	-----------------------

PROJECT TITLE
FIRE STATION ADD/ALTER, B3321
PROJECT NO. 1039839
17th TRAINING WING
GOODFELLOW AIR FORCE BASE, TEXAS

Project Number: 1039839
SHEET TITLE STRUCTURAL NOTES, SYMBOLS, & ABBREVIATIONS
Date: SEP 2023

SEQ.	SHEET	OF
06	S-001	50

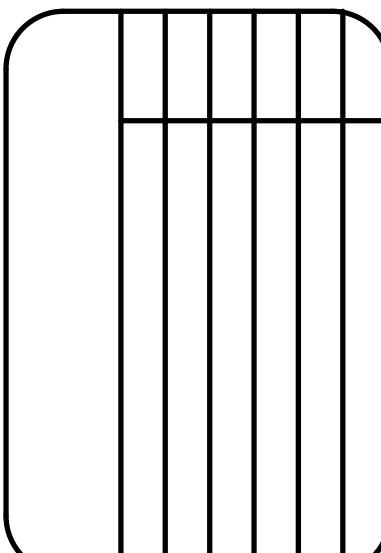
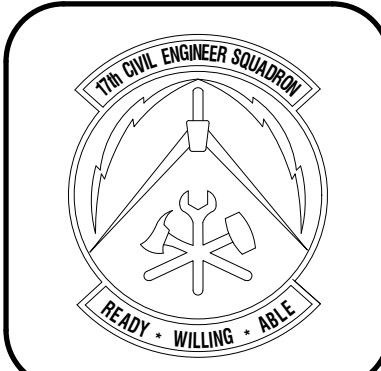

Designed by:
JHR/MLA
Drawn by:
JHR/MLA
Reviewed by:
RTJ/AH
Submitted by:
PCBS

PROJECT TITLE
**FIRE STATION ADD/ALTER, B3321
PROJECT NO. 1039839
17th TRAINING WING
GOODFELLOW AIR FORCE BASE, TEXAS**

Project Number:
1039839
SHEET TITLE
**FOUNDATION & FRAMING
PLAN**
Date:
SEP 2023

SEQ. SHEET OF
07 **S-101** 50

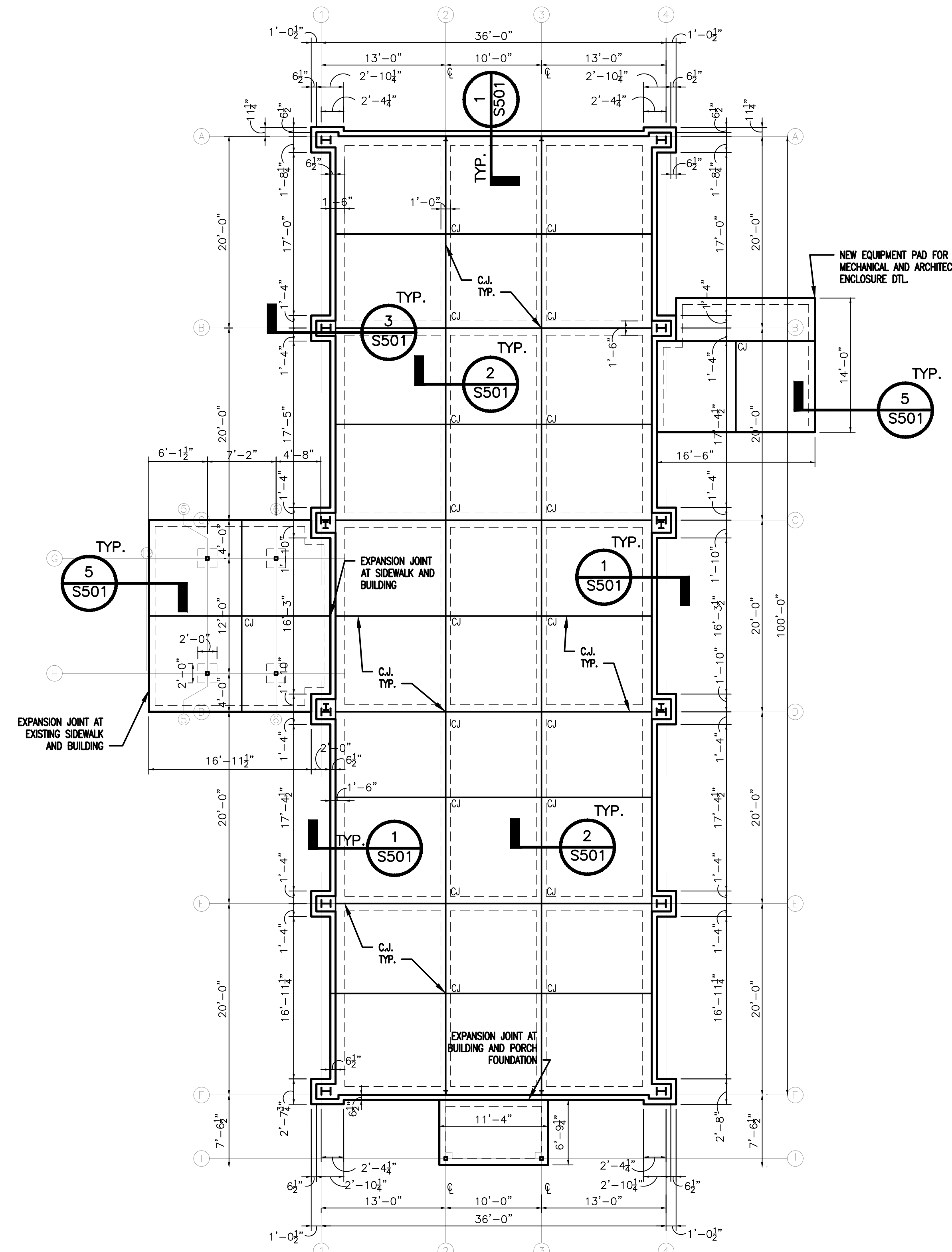

1 NEW ADDITION FRAMING PLAN
1/8" = 1' - 0"

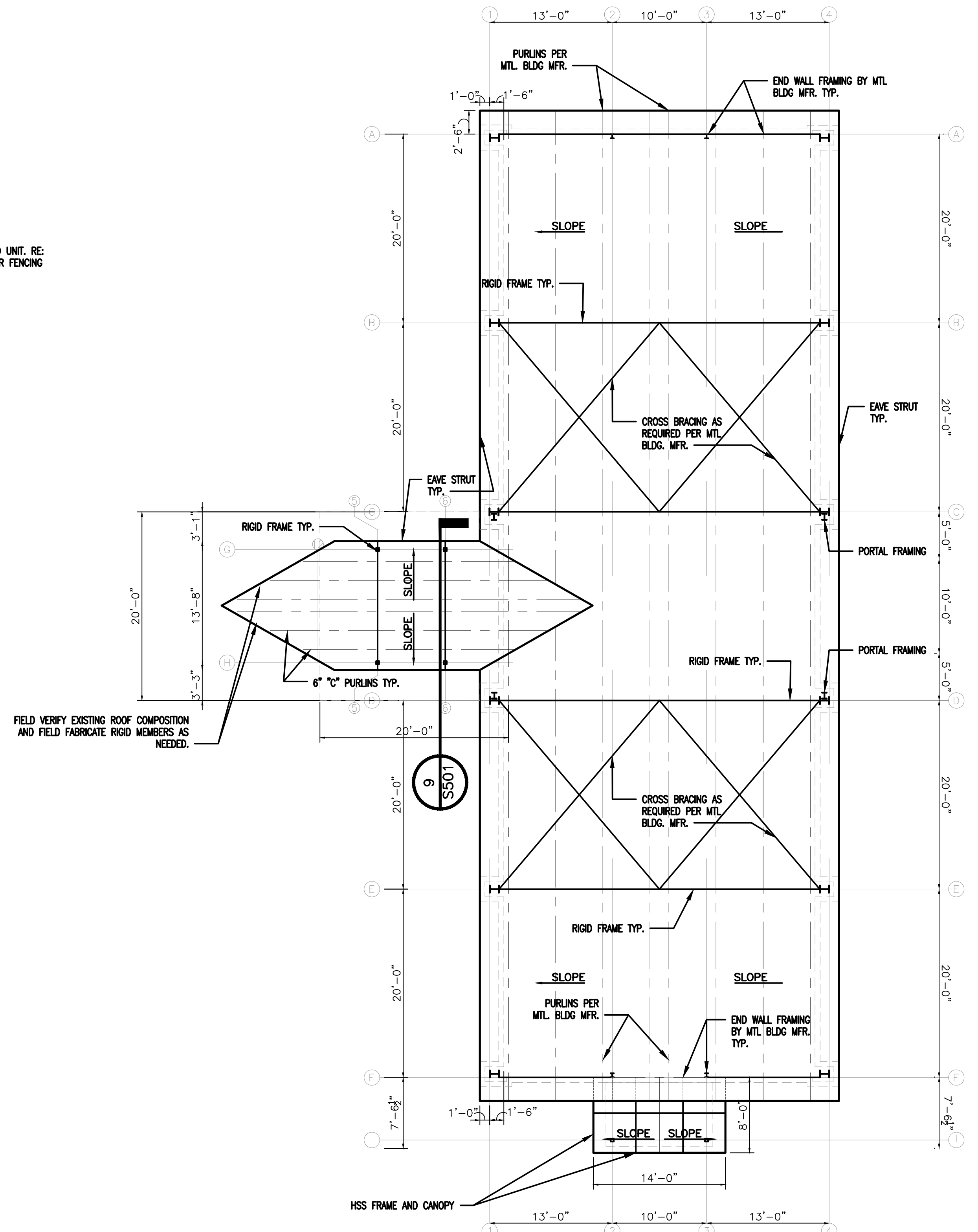
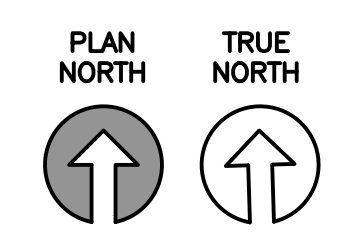

2 NEW ADDITION ROOFING PLAN
1/8" = 1' - 0"

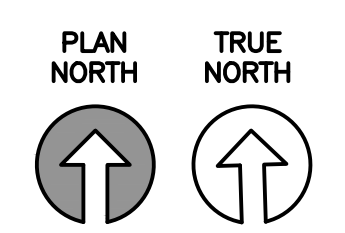

- CONCRETE FINISHES**
- CONCRETE SLABS TO RECEIVE "TROWEL" FINISH. RE: ARCHITECTURAL FOR ROOMS TO RECEIVE FLOOR HARDENER.
 - CONCRETE SURFACES EXPOSED TO PUBLIC VIEW TO RECEIVE LIGHT BROOM FINISH UNLESS NOTED OTHERWISE.
- NOTES: UNLESS NOTED OTHERWISE ON PLAN OR SECTION**
- DESIGN FOUNDATION BEARING PRESSURE (NET) 2 KSF.
 - PLACE 6" CAPILLARY WATER BARRIER AND VAPOR BARRIER UNDER ALL SLABS, U.N.O
 - CONSTRUCTION JOINTS (C.J.) SHALL BE PLACED AS SHOWN ON FOUNDATION PLANS THROUGH SLABS AND BEAMS
 - SEE GENERAL NOTES FOR CONCRETE PROTECTION FOR REINFORCING
 - FILL:
 - REMOVE 2'-0" OF EXISTING MATERIAL AND REPLACE WITH NON-EXPANSIVE FILL UNDER THE 6" CAPILLARY BARRIER.
 - ALL FILL PLACED UNDER BUILDING SLABS SHALL BE NON-EXPANSIVE AND SHALL BE COMPACTED TO NO LESS THAN 95% MAX. PROCTOR DENSITY ACCORDING TO ASTM D1557, METHOD D.
 - THE CONTRACTOR SHALL MAINTAIN POSITIVE DRAINAGE OF THE SITE DURING CONSTRUCTION. THE SITE SHALL BE MAINTAINED IN A DEWATERED CONDITION DURING THE ENTIRE CONSTRUCTION PERIOD. PONDING OF WATER IN AND AROUND THE CONSTRUCTION SITE WILL NOT BE PERMITTED. ANY WATER, EITHER GROUND OR SURFACE MUST BE CONTINUALLY REMOVED.
 - FLOOR ELEVATION OF NEW ADDITION SHALL MATCH EXISTING FIRE STATION.

- GENERAL NOTES**
- THESE DRAWINGS ARE FOR CONTRACTOR REFERENCE AND BIDDING PURPOSES ONLY. CONTRACTOR SHALL BE RESPONSIBLE FOR PROVIDING A PREFABRICATED, PRE-ENGINEERED METAL BUILDING AND CONCRETE FOUNDATION USING THE BASIS OF DESIGN PROVIDED ABOVE. CONTRACTOR SHALL PROVIDE NECESSARY SHOP DRAWINGS OF FOUNDATION AND FRAMING COMPONENTS WITH APPROPRIATE DETAILS SIGNED AND APPROVED BY A PROFESSIONAL ENGINEER.
 - CONTRACTOR SHALL VERIFY EXISTING DIMENSIONS, EQUIPMENT, AND CONDITIONS PRIOR TO START OF WORK.
 - ALL CONCRETE WORK SHALL BE PERFORMED BY THE CONTRACTOR IN ACCORDANCE WITH THE LATEST ACI STANDARD SPECIFICATIONS FOR CONCRETE AND REINFORCED CONCRETE 301-20.
 - CONTRACTOR SHALL ENSURE ALL CONCRETE SHALL BE STANDARD WEIGHT AND SHALL TEST AT 3000 PSI @ 28 DAYS.
 - ALL REINFORCING STEEL SHALL BE ASTM DESIGNATION A-615, GRADE 60, EXCEPT THAT GRADE 40 SHALL BE USED FOR BEAM STIRRUPS. DETAIL REINFORCING AND PROVIDE ACCESSORIES IN ACCORDANCE WITH THE LATEST ACI MANUAL OF STANDARD PRACTICE FOR DETAILING REINFORCED CONCRETE STRUCTURES.
 - UNLESS NOTED OTHERWISE, WHERE REINFORCING CONTINUOUS REINFORCING IS DESIGNATED, LAP TOP AND BOTTOM BARS AT 12" MIN. STAGGER LAPS. AT NON-CONTINUOUS ENDS OF ALL BEAMS AND SLABS PROVIDE ACI RECOMMENDED 90 HOOK FOR TOP BARS, EXCEPT AT CORNERS OMIT HOOK ON EXTERIOR TOP BARS AND PROVIDE "L" BARS (EXTERIOR HORIZONTAL TOP, BOTTOM AND ALL INTERMEDIATE BARS) LAPPING 12" MIN. IN EA. DIRECTION. CONTRACTOR SHALL BE RESPONSIBLE FOR INSTALLING PIPE AND DUCT SLEEVES IN GRADE BEAMS AS INDICATED ON MECHANICAL, ELECTRICAL, AND PLUMBING DRAWINGS. THESE SLEEVES SHALL BE STEEL AND SHALL NOT INTERFERE WITH THE STRUCTURAL FRAMING NOR SHALL THEY IMPAIR THE STRENGTH OF THE STRUCTURE.

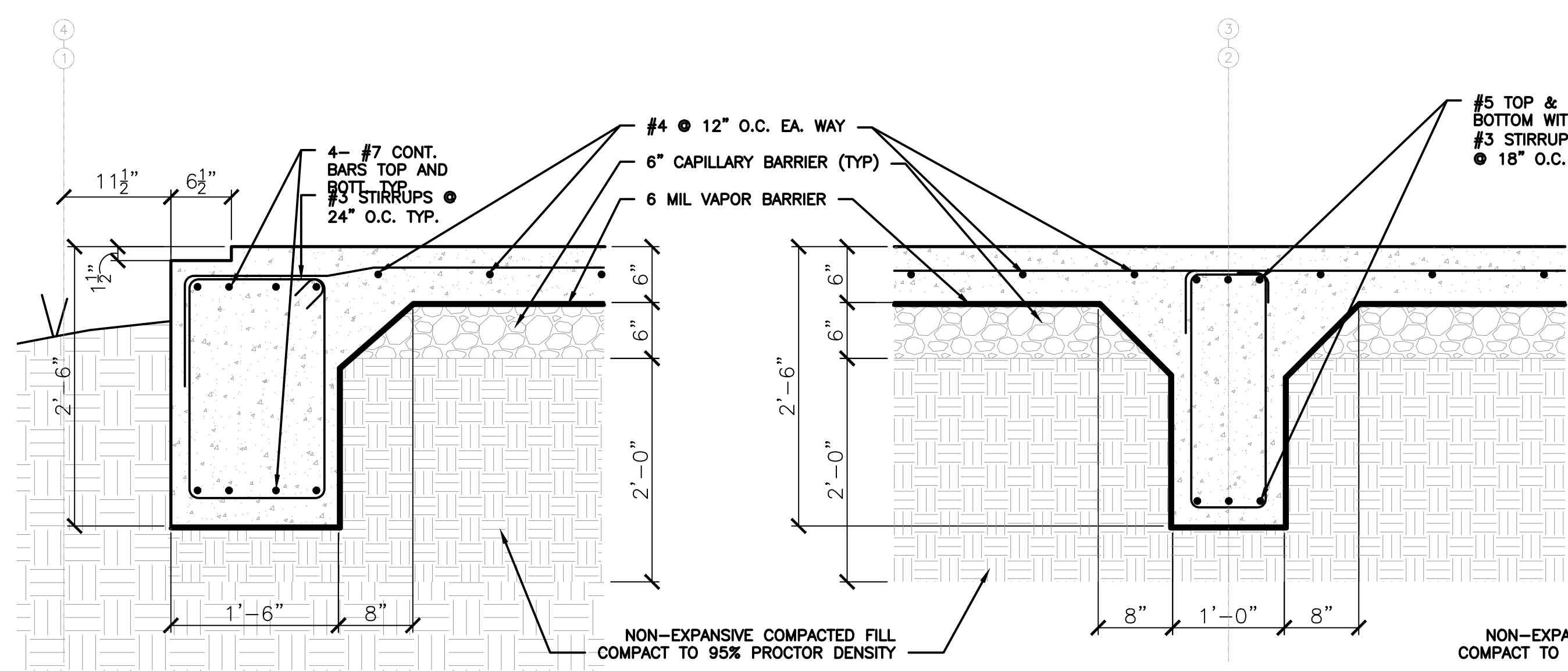
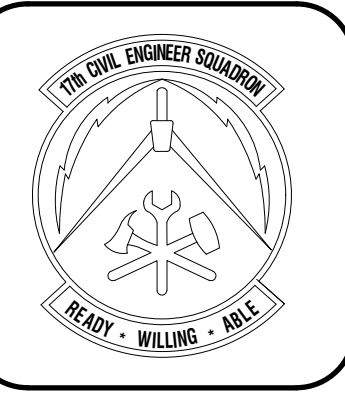

1 TYP. EXT. EDGE BEAM DTL.
1" = 1' - 0"

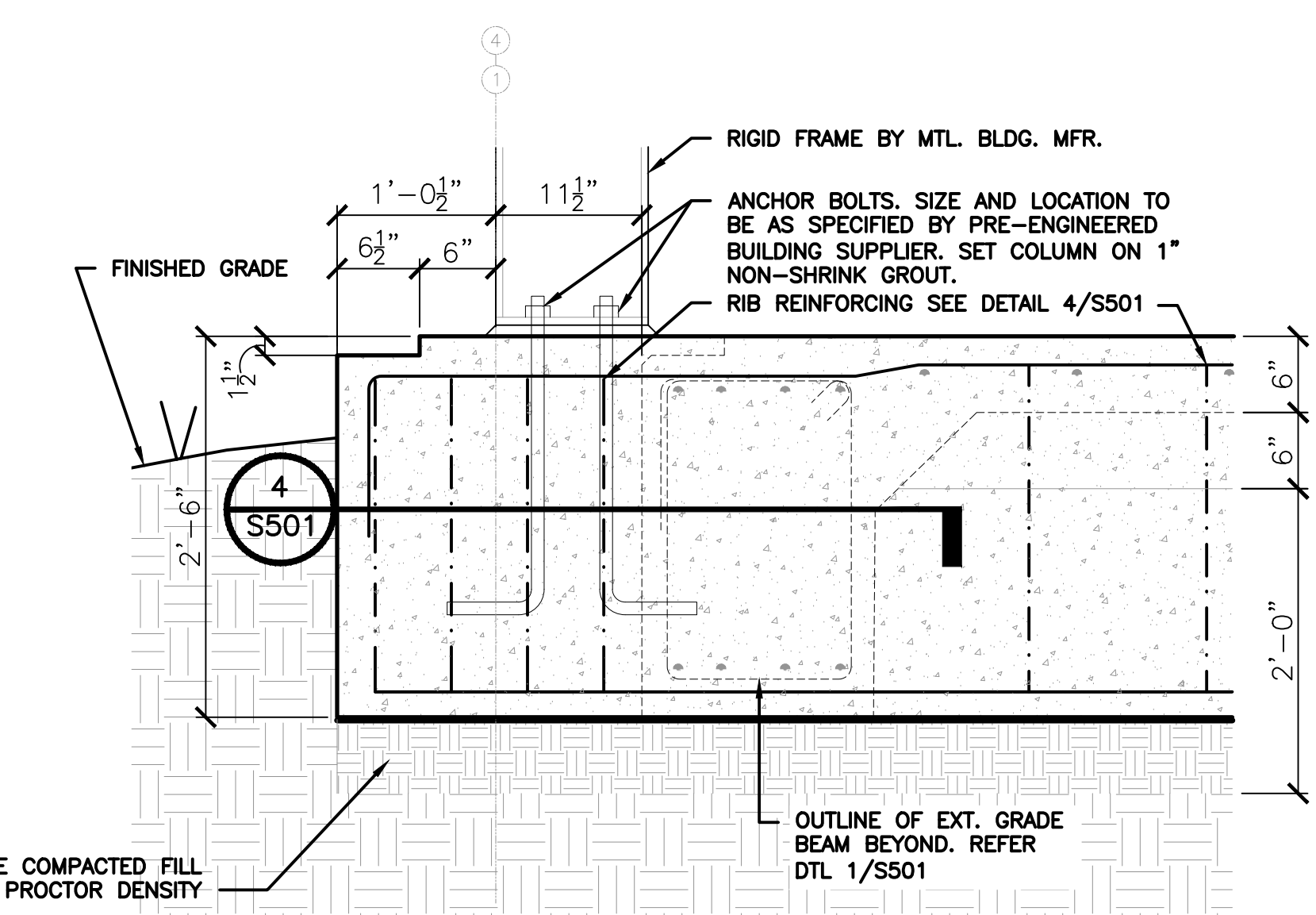

2 TYP. INT. GRADE BEAM DTL.
1" = 1' - 0"

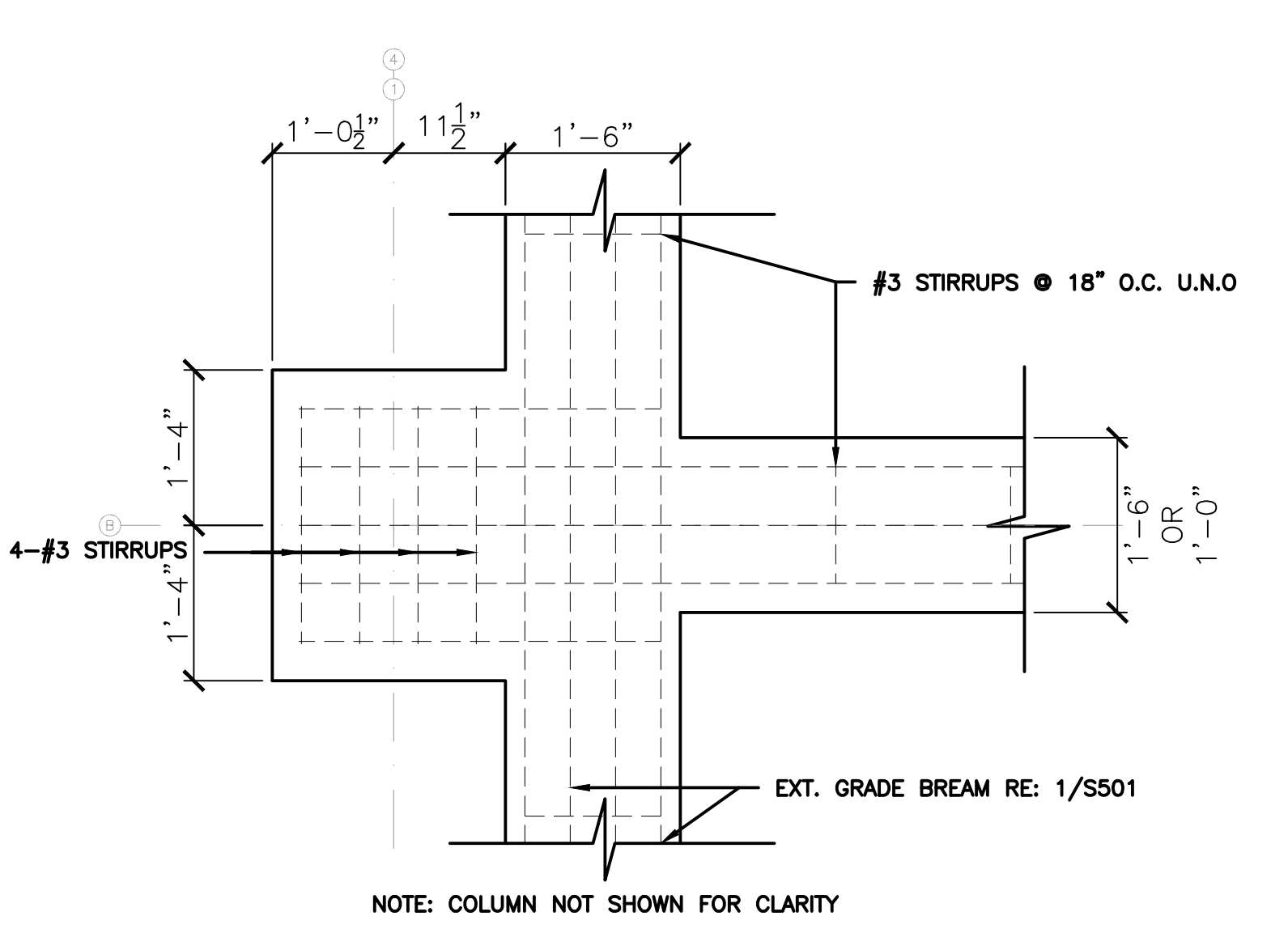

3 TYP. COL. FOOTING DTL.
1" = 1' - 0"

4 SECTION - GRADE BEAM
3/4" = 1' - 0"

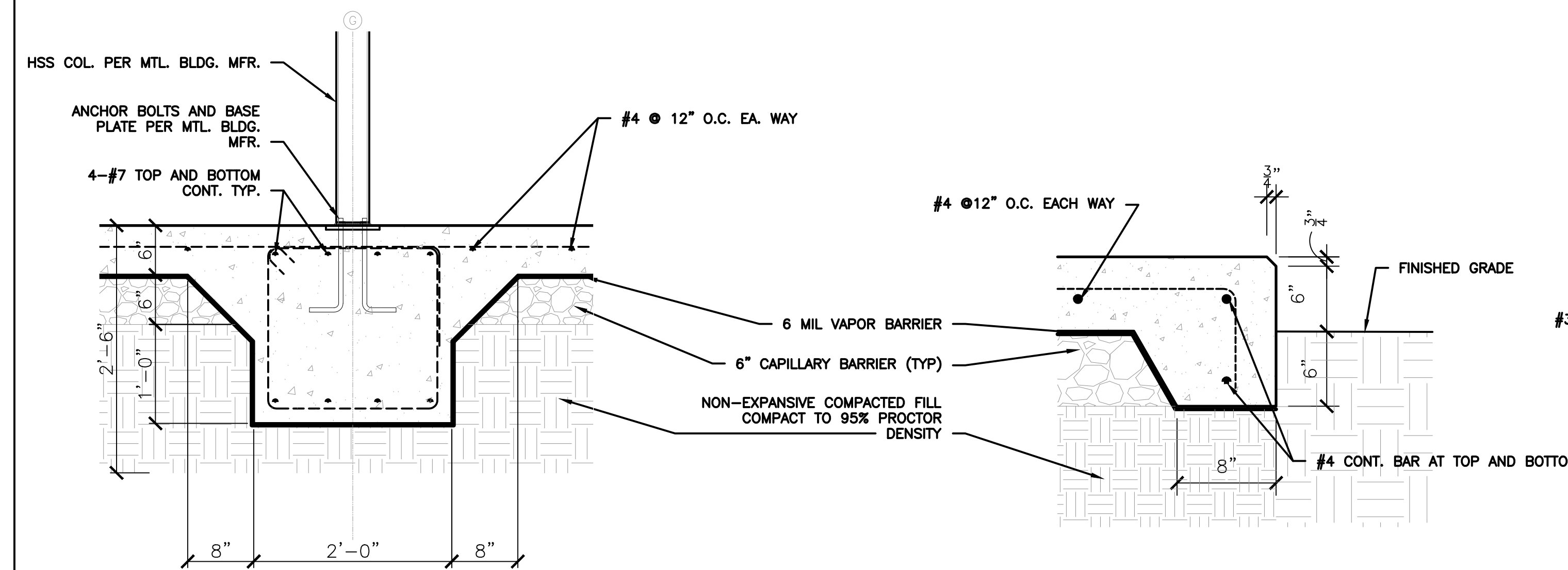

6 BREEZEWAY COL. DTL.
1" = 1' - 0"

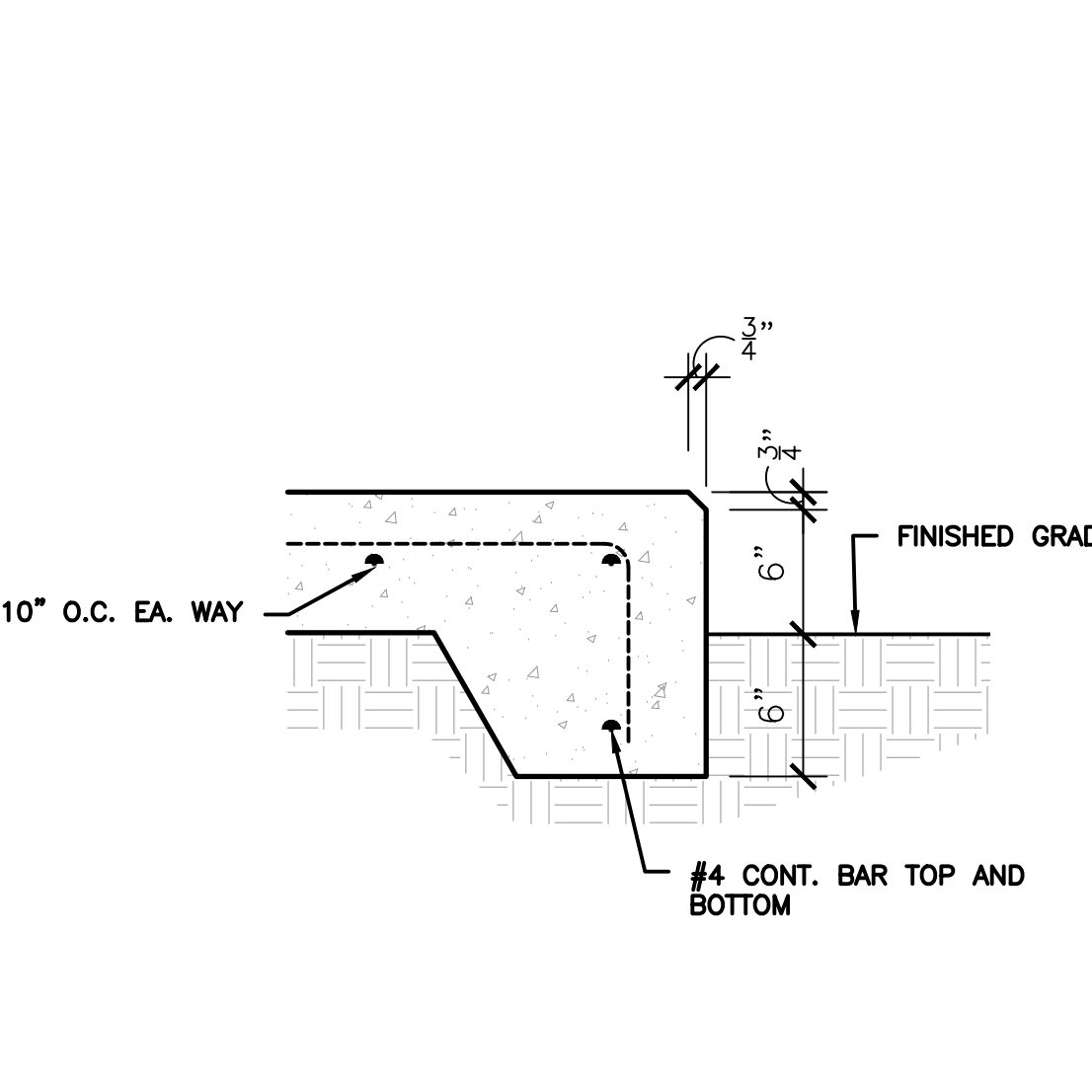

7 THICKENED SLAB EDGE DTL.
1-1/2" = 1' - 0"

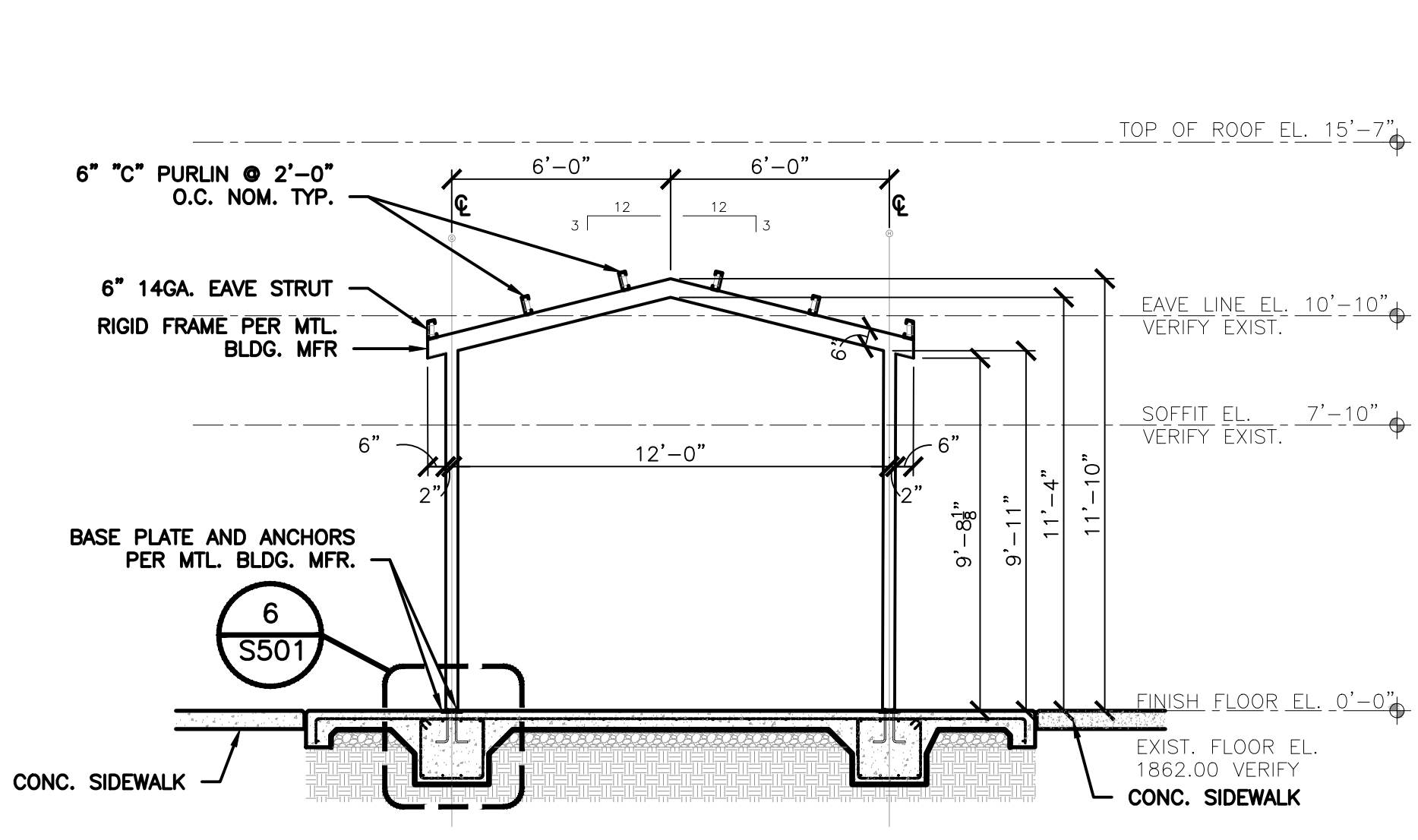

8 PACKAGED UNIT PAD DTL.
1-1/2" = 1' - 0"

9 BREEZEWAY SECTION
1/2" = 1' - 0"

STEEL STUD WALL HEADER AND JAMB SCHEDULE							
MAX SPAN	LOCATION	HEADER TYPE	HEADER SECTIONS	JAMB SECTIONS	HEADER CONNECTION TO JAMB		
					CONNECTION TYPE	F3 SCREWS	F2 SCREWS
6'-0"	EXTERIOR WALL	A	2 - 2-600S200-54	2 - 2-600S200-54	STIFFCLIP HE-43	8-#10	4-#10

10 TYP. HEADER AND JAMB SCHEDULE
3" = 1' - 0"

12 TYP. EXT. WALL MTL. STUD BASE MOUNTING DTL.
NTS

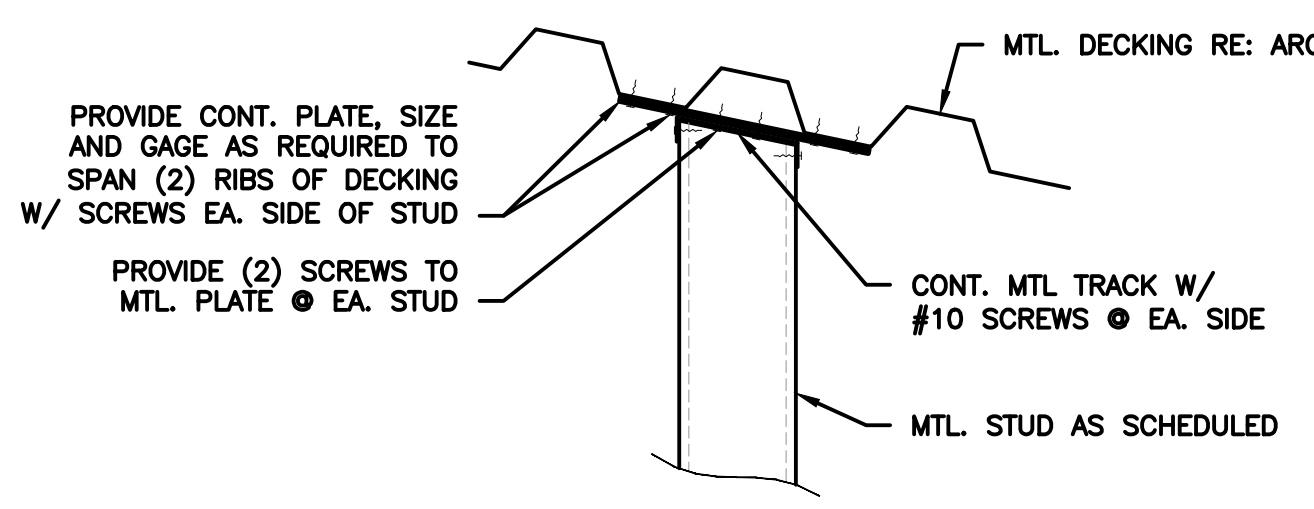

14 TYP. FRAMING DTL. - STUD @ MTL. DECKING
NTS

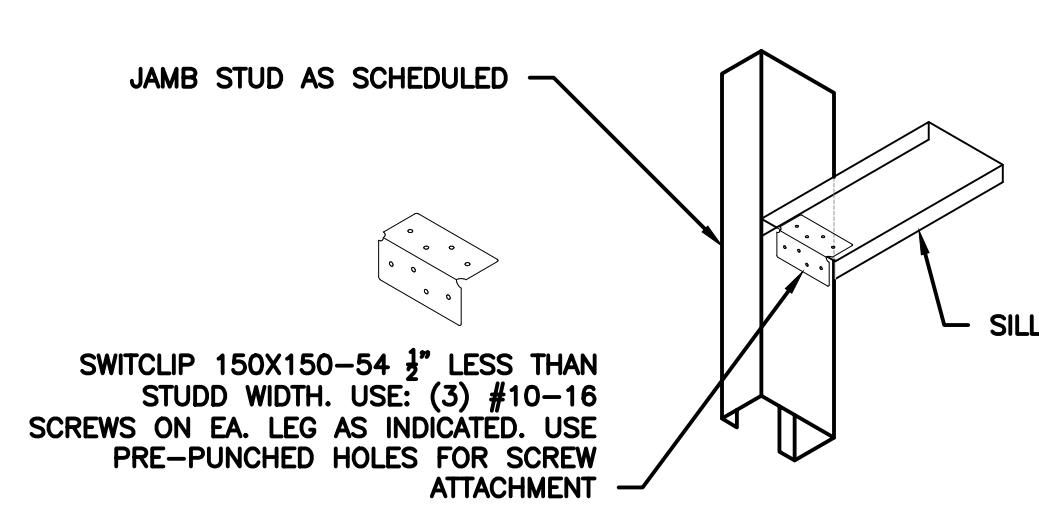

15 TYP. FRAMING DTL. - STUD @ MTL. DECKING
NTS

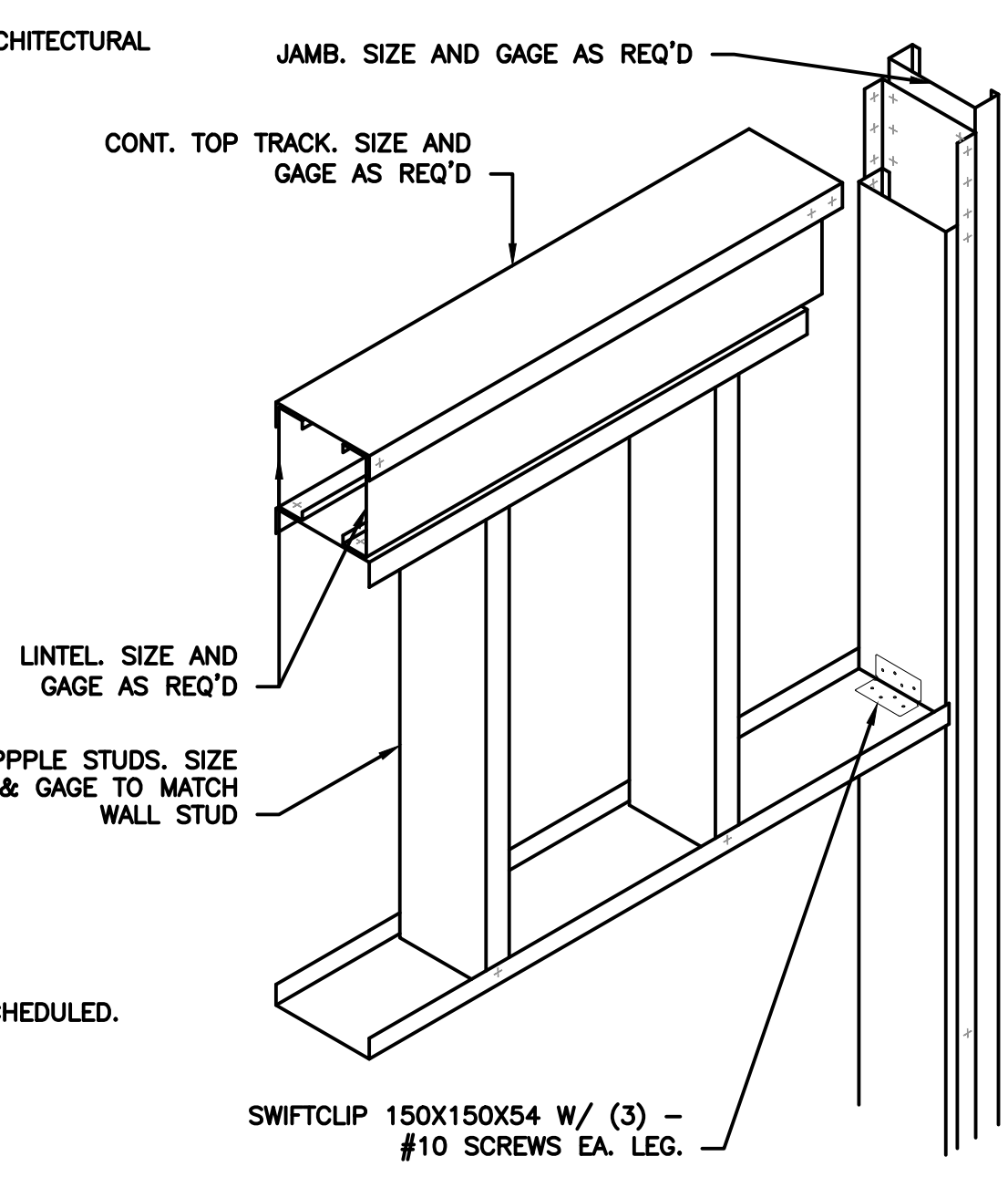

16 TYP. LOAD BEARING JAMB & HEADER DTL.
NTS

- GENERAL NOTES**
- THESE DRAWINGS ARE FOR CONTRACTOR REFERENCE AND BIDDING PURPOSES ONLY. CONTRACTOR SHALL BE RESPONSIBLE FOR PROVIDING A PREFABRICATED, PRE-ENGINEERED METAL BUILDING AND CONCRETE FOUNDATION USING THE BASIS OF DESIGN PROVIDED ABOVE. CONTRACTOR SHALL SUBMIT FOR APPROVAL NECESSARY SHOP DRAWINGS OF FOUNDATION AND FRAMING COMPONENTS WITH APPROPRIATE DETAILS STAMPED BY A PROFESSIONAL ENGINEER.
 - CONTRACTOR SHALL VERIFY EXISTING DIMENSIONS, EQUIPMENT, AND CONDITIONS PRIOR TO START OF WORK.
 - ALL CONCRETE WORK SHALL BE PERFORMED BY THE CONTRACTOR IN ACCORDANCE WITH THE LATEST ACI STANDARD SPECIFICATIONS FOR CONCRETE AND REINFORCED CONCRETE 301-20.
 - CONTRACTOR SHALL ENSURE ALL CONCRETE SHALL BE STANDARD WEIGHT AND SHALL TEST AT 3000 PSI @ 28 DAYS.
 - ALL REINFORCING STEEL SHALL BE ASTM DESIGNATION A-615, GRADE 60, EXCEPT THAT GRADE 40 SHALL BE USED FOR BEAM STIRRUPS. DETAIL REINFORCING AND PROVIDE ACCESSORIES IN ACCORDANCE WITH THE LATEST ACI MANUAL OF STANDARD PRACTICE FOR DETAILING REINFORCED CONCRETE STRUCTURES.
 - UNLESS NOTED OTHERWISE, WHERE REINFORCING CONTINUOUS REINFORCING IS DESIGNATED, LAP TOP AND BOTTOM BARS AT 12" MIN. STAGGER LAPS. AT NON-CONTINUOUS ENDS OF ALL BEAMS AND SLABS PROVIDE ACI RECOMMENDED 90 HOOK FOR TOP BARS, EXCEPT AT CORNERS OMIT HOOK ON EXTERIOR TOP BARS AND PROVIDE "L" BARS (EXTERIOR HORIZONTAL TOP, BOTTOM AND ALL INTERMEDIATE BARS) LAPPING 12" MIN. IN EA. DIRECTION.
 - CONTRACTOR SHALL BE RESPONSIBLE FOR INSTALLING PIPE AND DUCT SLEEVES IN GRADE BEAMS AS INDICATED ON MECHANICAL, ELECTRICAL, AND PLUMBING DRAWINGS. THESE SLEEVES SHALL BE STEEL AND SHALL NOT INTERFERE WITH THE STRUCTURAL FRAMING NOR SHALL THEY IMPAIR THE STRENGTH OF THE STRUCTURE.

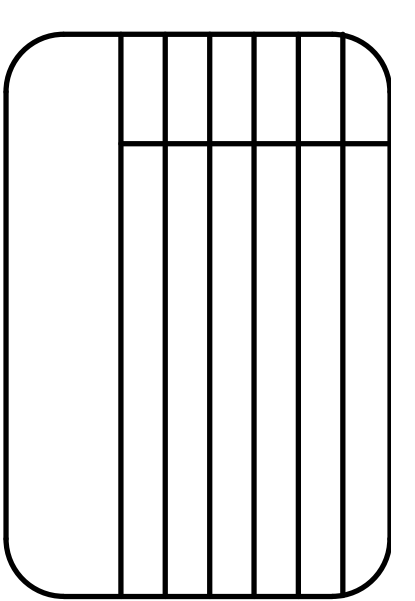

Designed by: JHR/M/L/A
 Drawn by: JHR/M/L/A
 Reviewed by: RTI/JH
 Submitted by: PCES

PROJECT TITLE
FIRE STATION ADD/ALTER, B3321
PROJECT NO. 1039839
17th TRAINING WING
GOODFELLOW AIR FORCE BASE, TEXAS

Project Number: 1039839
 SHEET TITLE: DETAILS
 Date: SEP 2023
 SEQ. SHEET OF: 08 **S-501** 50

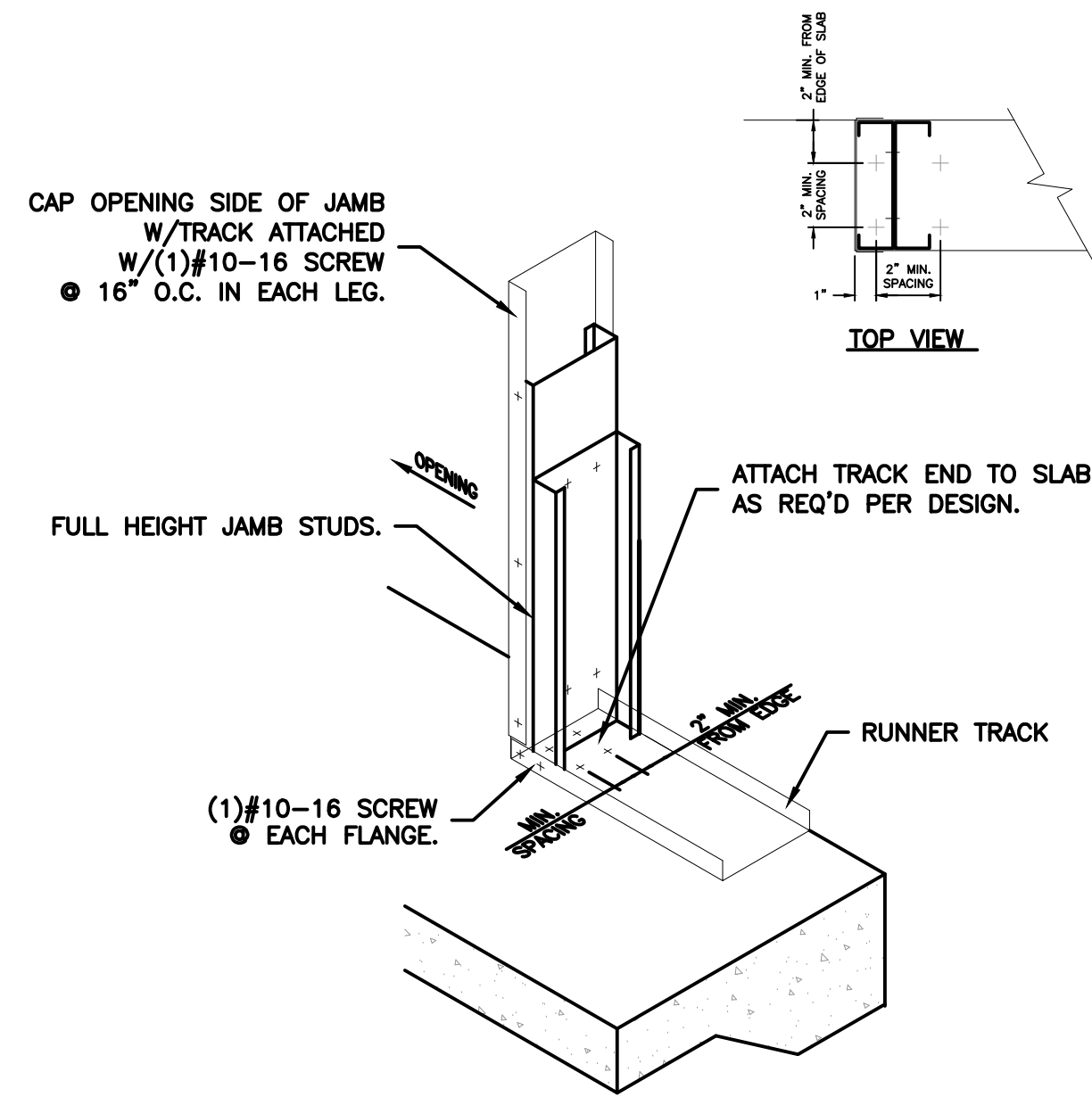

1 DOOR JAMB ANCHORAGE DTL. NTS

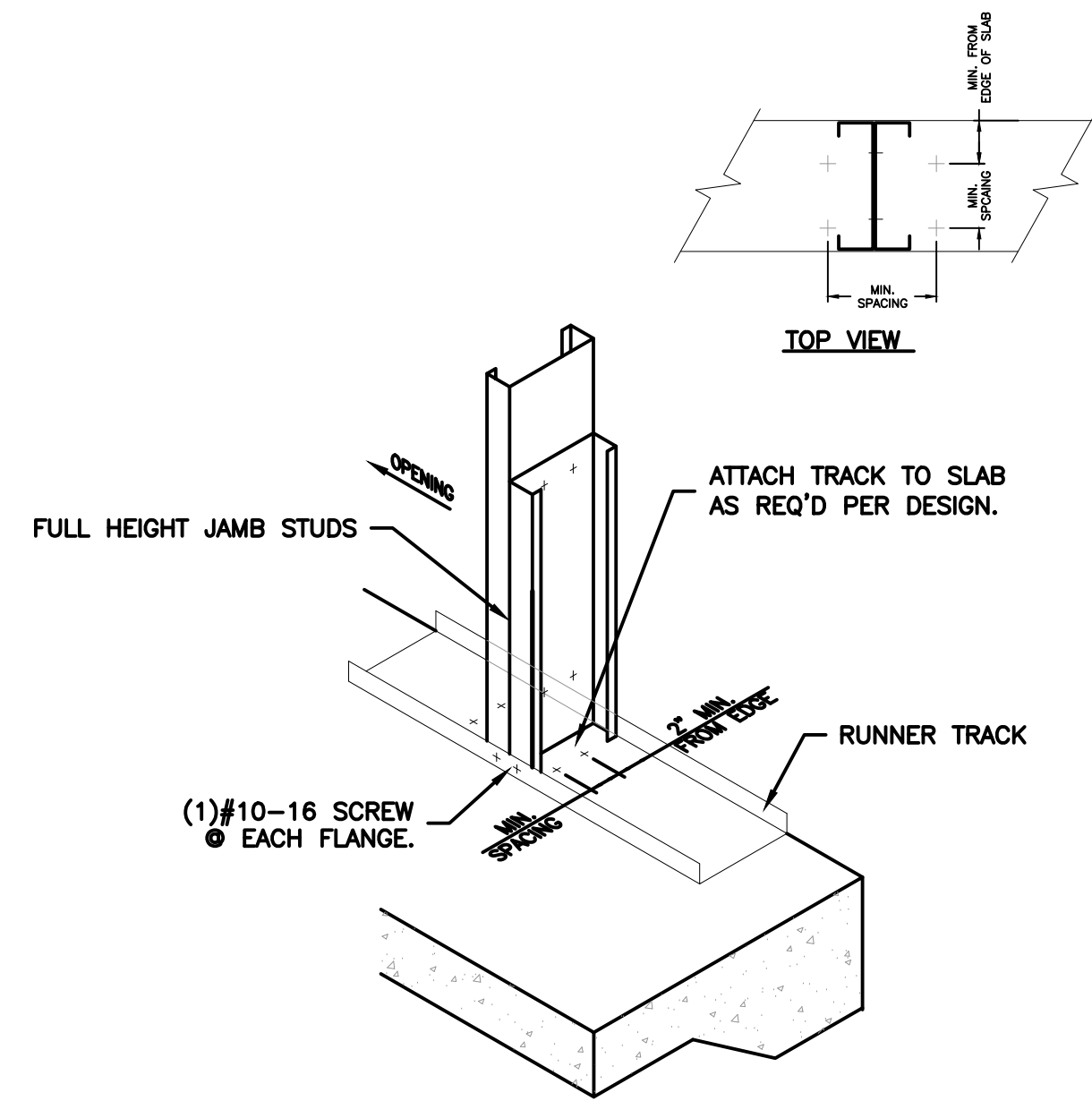

2 WINDOW JAMB ANCHORAGE DTL. NTS

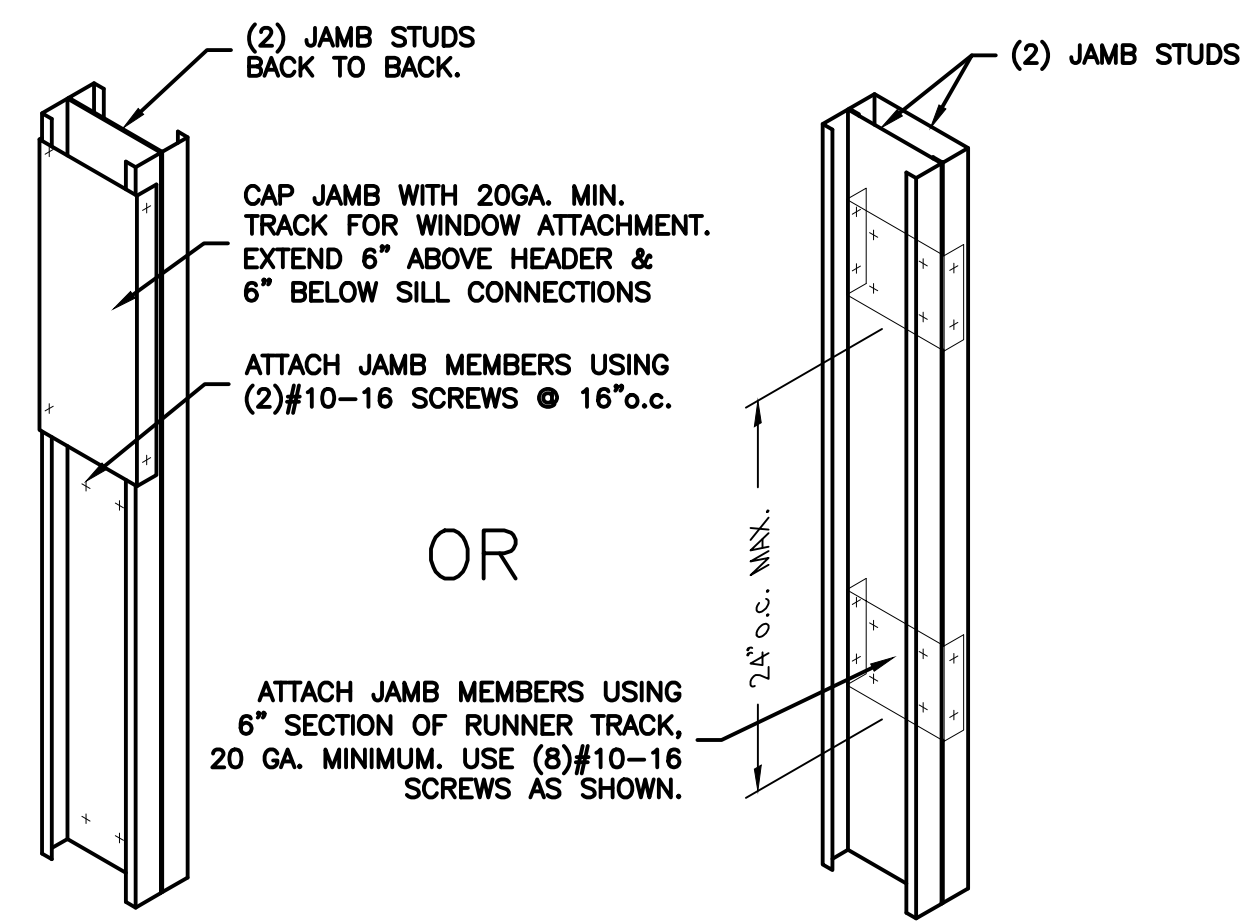

3 TYP. TIED JAMB STUD DTL. NTS

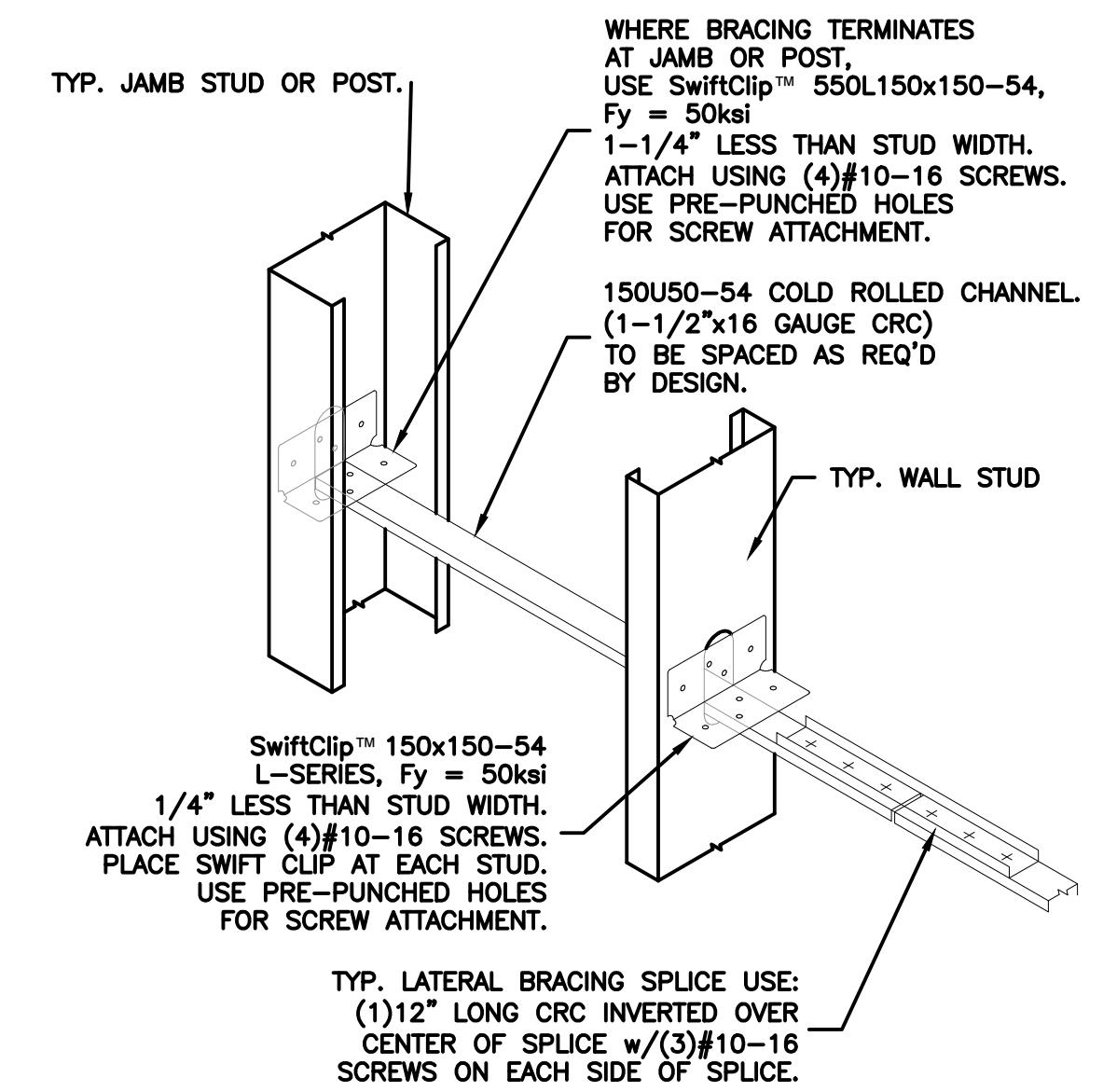

4 TYP. LATERAL BRACING DTL. NTS

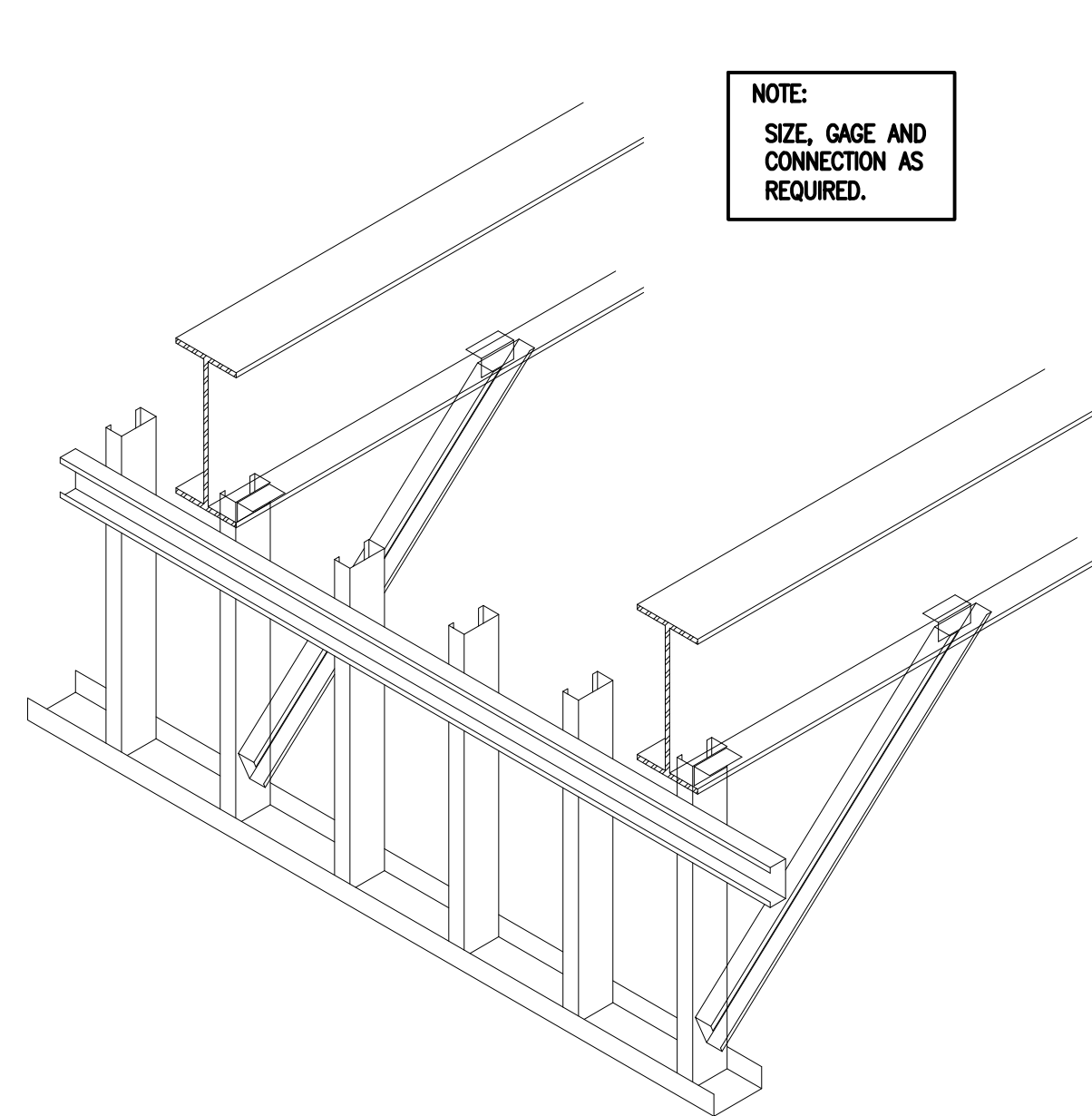

5 FASCIA DTL AT KICKED WALL NTS

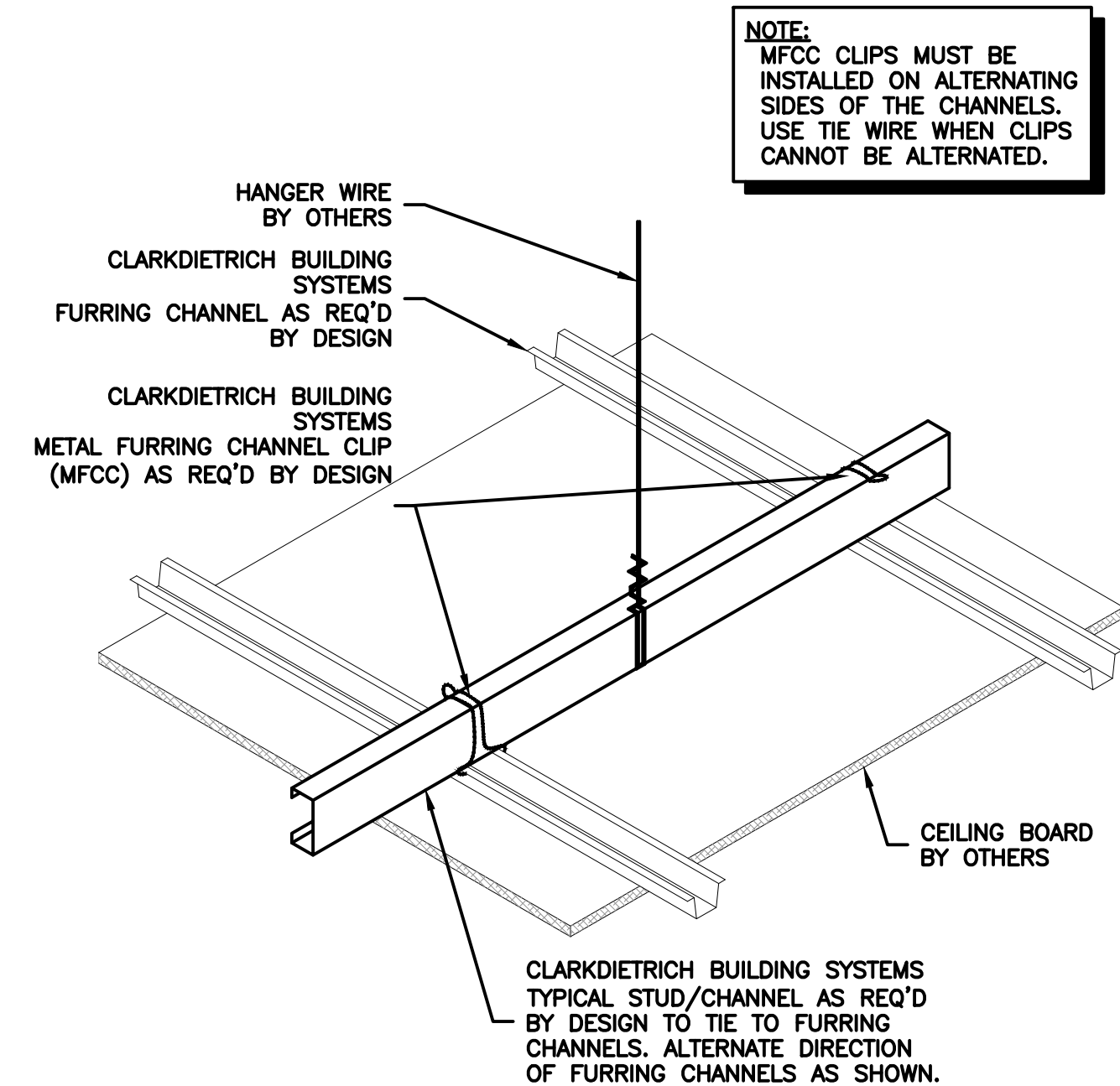

6 SUSP. CLG. FRAMING DTL - MTL FURRING CHANNELS NTS

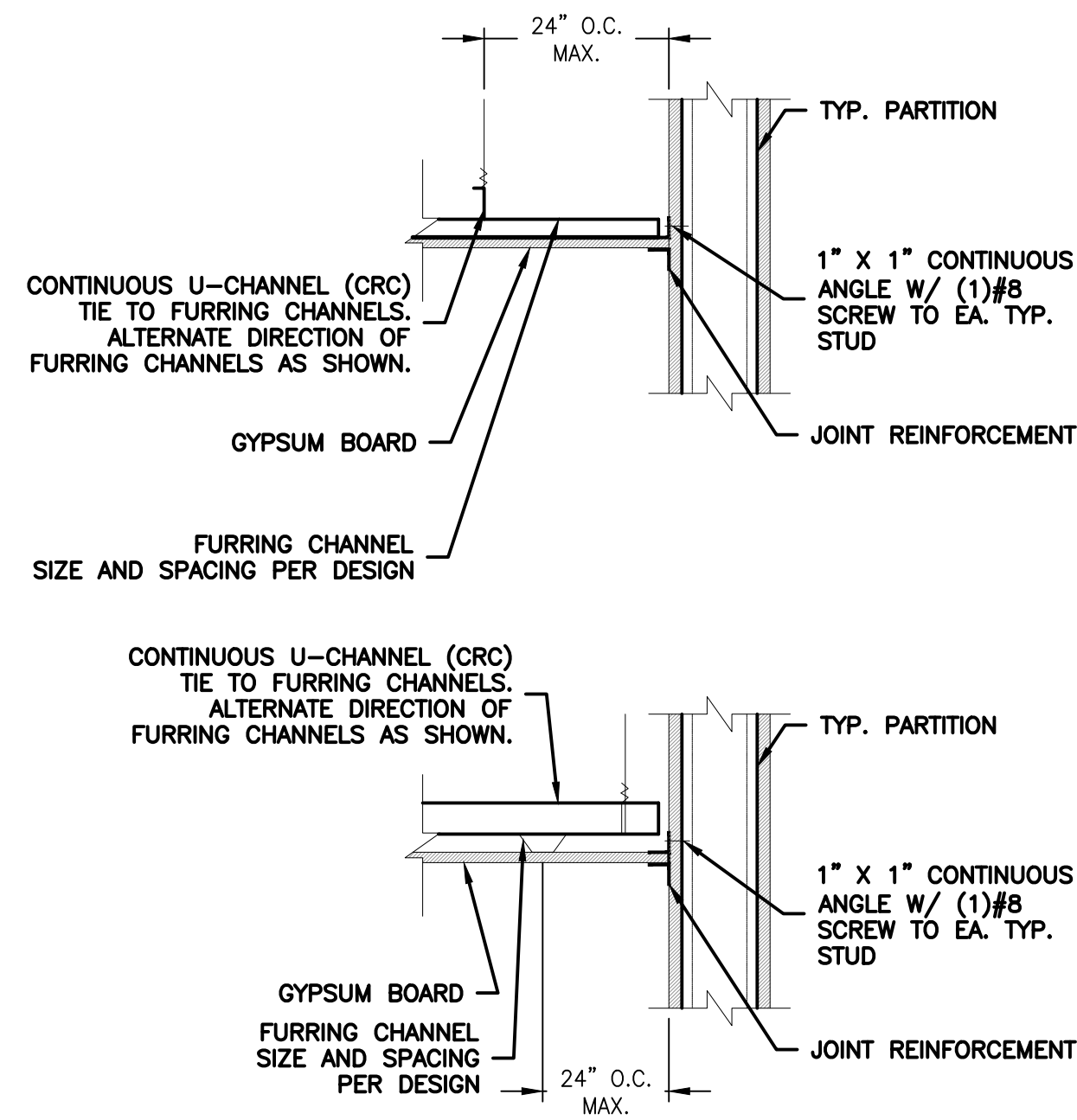

7 SUSP. CLG. FRAMING DTL - CEILING SECTION NTS

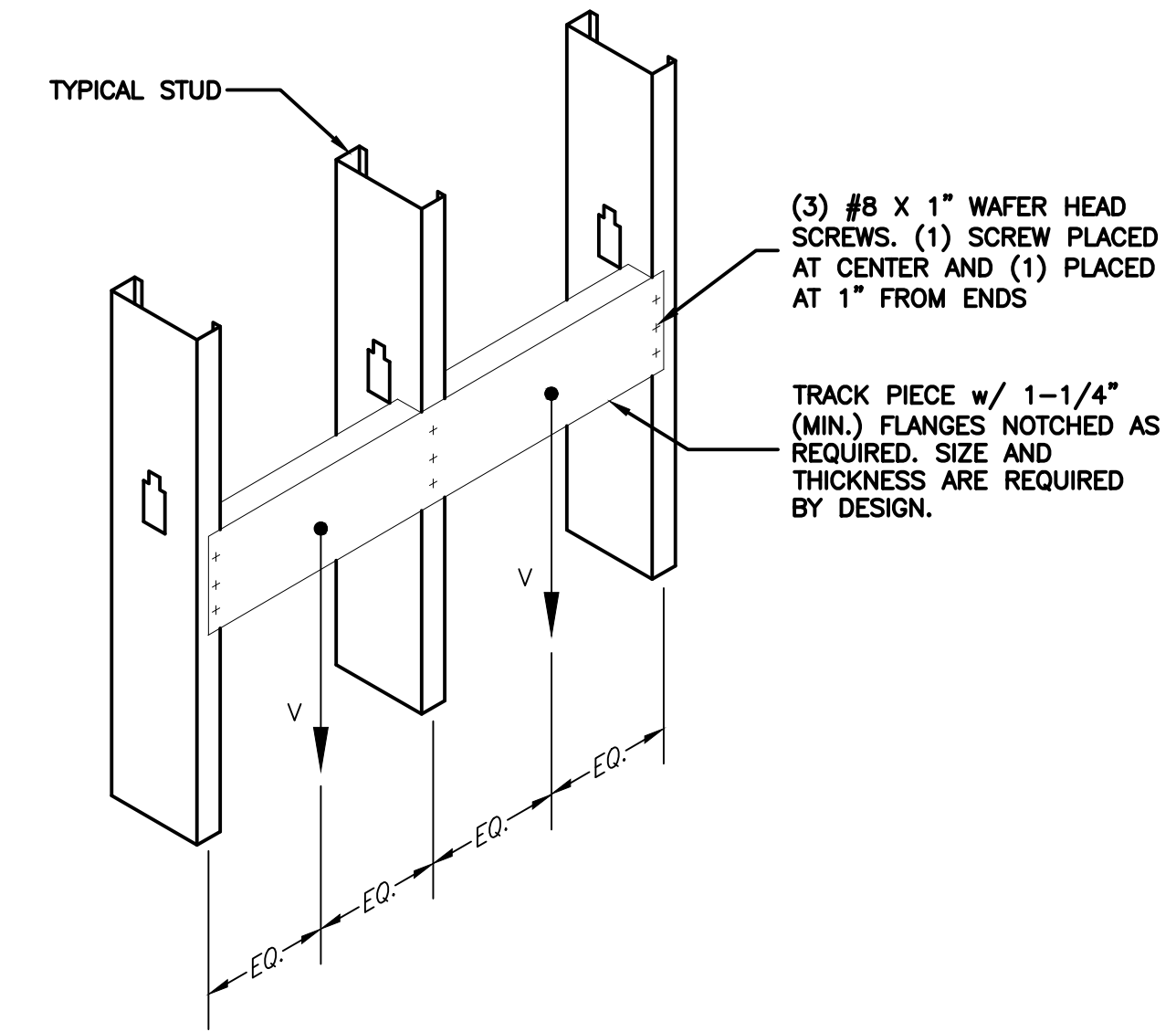

8 BACKING PLATE DTL. NTS

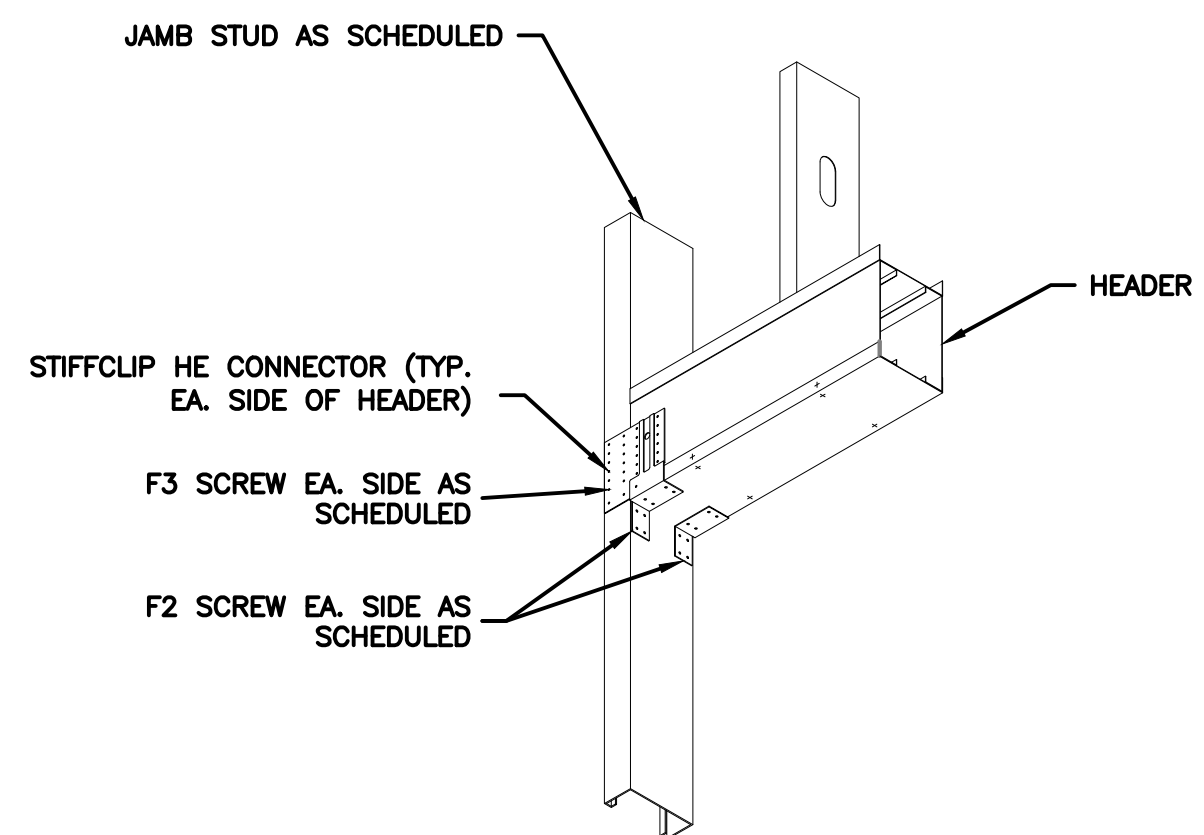

9 BOXED HEADER CONNECTION DTL. NTS

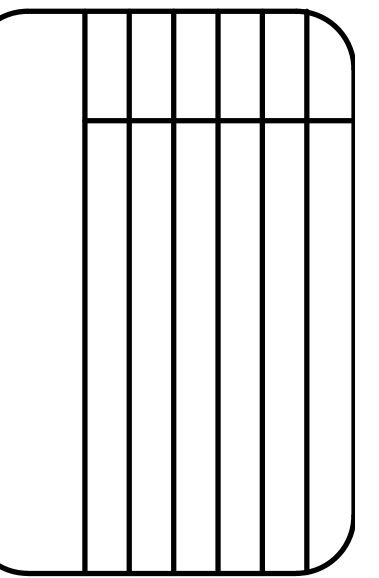
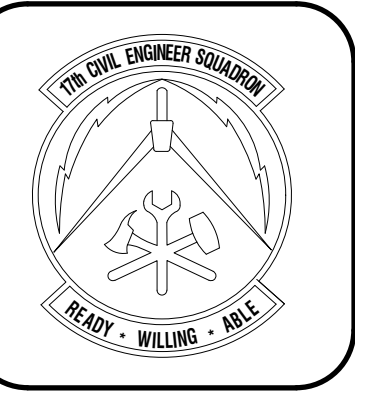

Designed by: JHR/LA
 Drawn by: JHR/LA
 Reviewed by: RTI/JH
 Submitted by: PCBS

PROJECT TITLE
 FIRE STATION ADD/ALTER, B3321
 PROJECT NO. 1039839
 17th TRAINING WING
 GOODFELLOW AIR FORCE BASE, TEXAS

Project Number: 1039839
 SHEET TITLE: DETAILS
 Date: SEP 2023

SEQ. SHEET OF
 09 S-502 50

GENERAL NOTES:

GENERAL NOTES:

1. CONSTRUCTION ACCESS TO THE BASE SHALL BE THROUGH THE EXISTING GATE LOCATED ON SOUTH CHADBOURNE STREET. ALL CONSTRUCTION TRAFFIC ENTERING THE BASE IS REQUIRED TO PASS THROUGH THE COMMERCIAL VEHICLE SEARCH AREA LOCATED TO THE EAST OF KEARNEY BOULEVARD. HOURS OF OPERATION ARE FROM 6:00 A.M. TO 2:00 P.M. MONDAY THROUGH FRIDAY, PHONE 325-654-1290.
2. CONTRACTORS SHALL KEEP ALL PUBLIC ROADS AND STREETS CLEAN OF CONSTRUCTION DEBRIS, MUD, ETC. AT ALL TIMES. CONTRACTOR SHALL PROVIDE EQUIPMENT AND PERSONNEL TO CLEAN ANY STREETS AS REQUESTED BY 17CES. CONTRACTOR IS RESPONSIBLE FOR ALL REPAIRS TO STREETS, PARKING AREAS AND BASE OR GOVERNMENT PROPERTY DAMAGED FROM THEIR CONSTRUCTION ACTIVITIES.
3. CONTRACTORS SHALL MAINTAIN A CONSTRUCTION SITE NEAT AND CLEAN OF DEBRIS AS DIRECTED BY CONTRACTING OFFICER. CONTRACTOR WASTE DUMPSTERS SHALL BE EMPTIED ON A REGULAR BASIS.

STAGING NOTES:

1. CONTRACTOR SHALL INSTALL AND MAINTAIN A TEMPORARY CONSTRUCTION CHAIN LINK FENCE, 6 FEET HIGH, AROUND THE LIMITS OF WORK NOT INCLUDING THE CONSTRUCTION ACCESS ROAD. COORDINATE CHAIN AND PADLOCKS ON GATES WITH GOODFELLOW FIRE DEPARTMENT. EACH GATE SHALL BE NUMBERED FOR EMERGENCY ACCESS. SHALL HAVE ENTRY/EGRESS SIGNAGE AND AREA LIGHTING. CONTRACTORS SHALL MAINTAIN FIRE ACCESS THROUGH EACH INDIVIDUAL CONSTRUCTION SITE AT ALL TIMES. CONTRACTOR SHALL MAINTAIN FIRE ACCESS TO EXISTING FIRE HYDRANTS ON SITE.
2. TRUCK WASHOUT AREA SHALL BE CONSTRUCTED, MAINTAINED AND CLEANED IN ACCORDANCE WITH TEXAS TCEQ REGULATIONS. PROVIDE DETAILS AND MAINTENANCE PLAN AS PART OF THE STORMWATER POLLUTION PREVENTION PLAN. STORMWATER PERMITS ARE REQUIRED PRIOR TO THE START OF CONSTRUCTION.
3. ALL CONTRACTORS SHALL STOCKPILE REQUIRED MATERIALS AND EQUIPMENT WITHIN LIMITS OF RESPECTIVE PROJECT AREAS OR STAGING AREA AS INDICATED ON THE DRAWINGS.
4. CONTRACTOR SHALL CONNECT TO EXISTING OR NEW FIRE HYDRANTS FOR TEMPORARY CONSTRUCTION WATER. INSTALL QUICK DISCONNECT, BACK FLOW PREVENTER AND SHUT-OFF VALVE ON 1 1/2" HOSE CONNECTION ONLY, PRIOR TO MAKING ANY CONNECTIONS TO BASE WATER SYSTEMS. THE CONTRACTOR MUST NOTIFY AND COORDINATE WITH 17CES. A FIRE PLUG USAGE PERMIT IS REQUIRED AND USAGE SHALL BE METERED AT ALL TIMES.
5. ALL TEMPORARY ELECTRIC POWER FACILITIES SHALL MEET OR EXCEED NESC AND NEC REQUIREMENTS AS APPLICABLE FOR PRIMARY AND SECONDARY FACILITIES.

ACCESS AND VEHICLE PARKING:

1. ACCESS TO THE PROJECT FOR ALL CONSTRUCTION PERSONNEL, VEHICLES AND EQUIPMENT IS ILLUSTRATED ON THE STAGING/LAYDOWN AND ACCESS PLAN. ACCESS ROUTES MAY BE SUBJECT TO CHANGE BASED ON OPERATIONAL REQUIREMENTS. POTENTIAL SCHEDULE IMPACTS SHALL BE COORDINATED WITH 17CES.
2. LOCATION OF ACCESS/HAUL ROADS ARE AS INDICATED ON SHEET G-001 AND G-002.
3. ALL HAUL ROADS SHALL BE MAINTAINED SUCH THAT UNOBSTRUCTED ACCESS WILL BE PROVIDED AT ALL TIMES FROM THE ROAD TO THE STAGING AREA TO THE WORK SITE AND FACILITATE GOVERNMENT ACCESS TO THE BASE AT ALL TIMES. THE MAINTENANCE OF HAUL ROADS SHALL BE THE RESPONSIBILITY OF THE CONTRACTOR AT NO ADDITIONAL COST TO THE GOVERNMENT. THE HAUL ROAD LOCATIONS SHALL BE AS INDICATED ON SHEET G-001 AND G-002.
4. CONTRACTOR SHALL COORDINATE ACTIVITIES THROUGHOUT THE PROJECT IN A MANNER THAT ALLOWS EMERGENCY ACCESS TO ALL EXISTING ROADWAYS AT ALL TIMES WITHOUT DELAYS TO EMERGENCY VEHICLES RESPONSE TIME.
5. ALL CONTRACTOR VEHICLES AND PERSONNEL MAY BE SEARCHED BY SECURITY FORCES WHEN ENTERING THE BASE AND MAY EXPERIENCE DELAYS. ALL PERSONNEL ENTERING GOODFELLOW AFB. MUST HAVE A VALID PHOTO ID PER BASE SECURITY REQUIREMENTS. ALL VEHICLES ENTERING THE BASE MUST HAVE CURRENT/VALID REGISTRATION, CURRENT/VALID INSURANCE AND CURRENT/VALID INSURANCE AND CURRENT/VALID DRIVERS LICENSE FOR THE OPERATOR. ALL DRIVERS MUST COMPLY WITH ALL GOODFELLOW AFB DRIVING REQUIREMENTS (SPEED LIMITS, SEATBELTS, ETC.)
6. WHEN NOT ENGAGED IN CONSTRUCTION ACTIVITIES, THE CONTRACTOR'S CONSTRUCTION EQUIPMENT AND VEHICLES SHALL BE PARKED WITHIN THE WORK AREA OR STAGING AREA.
7. THE CONTRACTOR SHALL ENSURE 24 HOUR ACCESS TO VANCE ST. TO AVOID DISRUPTION TO EMERGENCY SERVICES. VANCE ST. SHALL MAINTAIN OPERABILITY THROUGHOUT THE LIFE OF THE CONTRACT.

COORDINATION AND COMMUNICATION DURING CONSTRUCTION:

1. PRIOR TO CONSTRUCTION, THE CONTRACTOR SHALL CORDON OFF THE WORK AREAS AND STREET CROSSINGS BY USING APPROVED BARRICADES.

TRAFFIC CONTROL:

1. ONLY RUBBER-TIRED VEHICLES SHALL BE ALLOWED ON EXISTING PAVEMENT THAT IS TO REMAIN.
2. ANY DAMAGE TO ROADS AND PAVEMENT DUE TO CONSTRUCTION EQUIPMENT, CONSTRUCTION TRAFFIC OR CONSTRUCTION ACTIVITY SHALL BE REPAIRED TO THEIR ORIGINAL CONDITION BY THEY CONTRACTOR AT HIS/HER OWN EXPENSE.

EQUIPMENT AND STOCKPILE HEIGHT:

1. STOCKPILE ALL CONSTRUCTION MATERIALS WITHIN STAGING AREA. MAXIMUM HEIGHT 15.00' WITH 5:1 SIDE SLOPES. PROVIDE EROSION CONTROL PROTECTION AROUND THE STOCKPILE LIMITS. ANY MATERIALS THAT ARE TO BE STOCKPILED FOR USE FOR OTHER PROJECTS ON THE BASE SHALL BE COORDINATED WITH 17CES. ALL MATERIAL NOT REQUIRED SHALL BE HAULED OFF GOVERNMENT PROPERTY.

EXCAVATION AND TRENCHES:

1. OPEN TRENCHES AND EXCAVATIONS AT THE CONSTRUCTION SITE SHALL BE PROMINENTLY MARKED WITH ORANGE AND WHITE TYPE III BARRICADES AND WITH FLASHING TYPE A-LOW INTENSITY WARNING LIGHTS FROM DUSK TILL DAWN.

OTHER SAFETY REQUIREMENTS:

1. CONTRACTOR SHALL MAINTAIN SAFETY PRACTICES THAT CONFORM TO OCCUPATIONAL SAFETY AND HEALTH ADMINISTRATION (OSHA) REGULATIONS.
2. CONTRACTOR SHALL MAINTAIN AT ALL TIMES ONE FIRE LANE FREE FROM OBSTRUCTION AND MAINTAIN ACCESS TO THE SITE AND ALL SURROUNDING ROADS AND STREETS.

CONTRACTOR SAFETY PLAN SUBMITTALS

1. CONTRACTOR SHALL FURNISH A CONSTRUCTION SAFETY PLAN IN ACCORDANCE WITH THE SPECIFICATIONS WITH THE PROJECT SCHEDULE. THE SAFETY PLAN SHALL IDENTIFY THE FOLLOWING ITEMS:
 - 1.1. PROPOSED ACCESS POINTS, STAGING AREA AND HAUL ROUTES.
 - 1.2. TEMPORARY MARKINGS TO BE USED, IF ANY.
 - 1.3. LOCATIONS AND TYPE OF BARRICADES OR OTHER TRAFFIC CONTROL DEVICES.
 - 1.4. METHODS BY WHICH THE CONTRACTOR WILL COMMUNICATE WITH 17 CES.

MAINTENANCE OF STORAGE AREA

1. THE CONTRACTOR SHALL AT ALL TIMES KEEP THE CONSTRUCTION SITE, CONSTRUCTION TRAILER(S)/BUILDING(S), AND STORAGE AREA(S) IN A CLEAN, NEAT, WORKMAN LIKE CONDITION, FREE FROM ACCUMULATION OF WASTE, RUBBISH, WEEDS, OVERGROWN GRASS, OR CONSTRUCTION DEBRIS, TO THE SATISFACTION OF THE CONTRACTING OFFICER. ALL LOOSE OR LIGHT WEIGHT MATERIALS SHALL BE SECURED

TO PREVENT BLOWING OR SCATTERING. THE BURNING OF TRASH OR CONSTRUCTION DEBRIS IS STRICTLY PROHIBITED ON GOODFELLOW AFB. PRIOR TO FINAL INSPECTION, THE CONTRACTOR SHALL REMOVE ALL CONSTRUCTION DEBRIS, TOOLS, EQUIPMENT, AND MATERIALS NOT THE PROPERTY OF THE GOVERNMENT. UPON COMPLETION OF THE WORK, THE CONTRACTOR SHALL LEAVE THE WORK SITE AND STORAGE AREA(S) IN A CLEAN, NEAT, AND WORKMANLIKE CONDITION SATISFACTORY TO THE CONTRACTING OFFICER. REFER TO STATEMENT OF WORK.

2. THE CONTRACTOR SHALL KEEP FENCING IN A STATE OF GOOD REPAIR AND PROPER ALIGNMENT. GRASSED OR UNPAVED AREAS, WHICH ARE NOT ESTABLISHED ROADWAYS, WILL BE COVERED WITH A LAYER OF GRAVEL AS NECESSARY TO PREVENT RUTTING AND THE TRACKING OG MUD ONTO PAVED OR ESTABLISHED ROADWAYS. SHOULD THE CONTRACTOR ELECT TO TRAVERSE THEM WITH CONSTRUCTION EQUIPMENT OR OTHER VEHICLES; GRAVEL GRADATION WILL BE AT THE CONTRACTOR'S DISCRETION. MOW AND MAINTAIN GRASS LOCATION WITHIN THE BOUNDARIES OF THE CONSTRUCTION SITE FOR THE DURATION OF THE PROJECT. GRASS AND VEGETATION ALONG FENCES, BUILDINGS, UNDER TRAILERS, AND IN AREAS NOT ACCESSIBLE TO MOWERS WILL BE EDGED OR TRIMMED NEATLY.
3. GRASS AND WEEDY VEGETATION WITHIN THE AREAS UTILIZED BY THE CONTRACTOR, INCLUDING WORK AREAS, ADMINISTRATIVE AREAS, AND STORAGE AREAS, SHALL BE KEPT MOWED TO CONTROL VEGETATION GROWTH. VEGETATION SHALL BE MOWED WHEN IT REACHES A HEIGHT OF 6 INCHES. MOWING SHALL BE TO A HEIGHT OF 3 INCHES. MOVING SHALL BE ACCOMPLISHED WITH A ROTARY MOWER THAT LEAVES THE CLIPPINGS EVENLY DISTRIBUTED ON THE SOIL SURFACE. MOWING SHALL BE ACCOMPLISHED DURING PERIODS AND IN SUCH A MANNER THAT THE SOIL AND GRASS WILL NOT BE DAMAGED. TOWED OR SELF-PROPELLED RIDING MOWERS SHALL NOT BE OPERATED WITHIN 3 FEET OF TREES OR SHRUBS. AREAS ADJACENT TO TREES AND SHRUBS SHALL BE MOWED WITH HAND-PROPELLED MOWERS.
4. EROSION CONTROL DEVICES SHALL BE USED FOR THE STAGING AREA AND ANY MATERIAL STOCK PILES WHEN NECESSARY TO CONTROL EROSION AND STORM WATER RUNOFF IN ACCORDANCE WITH FEDERAL, STATE, AND LOCAL REGULATIONS.
5. AREAS NOT MOWED: GOVERNMENT MAY IMMEDIATELY AFTER NOTICE TO THE CONTRACTOR AND THE DISCRETION OF THE CONTRACTING OFFICER MOW THE CONTRACTOR'S AREAS AT ANY TIME THE VEGETATION HEIGHT EXCEEDS 6 INCHES.

WATERING

1. THE CONTRACTOR SHALL COMPLY WITH THE CURRENT CITY OF SAN ANGELO, TEXAS WATER CONSERVATION AND DROUGHT CONTINGENCY PLAN FOR ALL ON BASE WATER USAGE.
2. EXISTING INFORMATION SHOWN WAS TAKEN FROM AS BUILT DRAWINGS PROVIDED BY GOODFELLOW AIR FOR BASE (GAFB) AND A WALK-THRU OF THE FACILITY. THE CONTRACTOR SHALL FIELD VERIFY THE EXISTING CONDITIONS PRIOR TO BID AND NOTIFY THE CONTRACTING OFFICER OF ANY SUBSTANTIAL DISCREPANCIES WHICH WOULD IMPACT BASIS OF DESIGN AND CONSTRUCTION.
3. CONTRACTOR SHALL VISIT THE JOB SITE TO FAMILIARIZE THEMSELVES WITH EXISTING CONDITIONS AND TO VERIFY LOCATIONS, SIZE AND QUANTITIES OF EXISTING UTILITIES, MECHANICAL SYSTEMS, PLUMBING SYSTEMS, ETC. SUBMITTAL OF A BID SHALL SIGNIFY WILLINGNESS TO COMPLY WITH THE CONSTRUCTION DOCUMENTS AND ACCEPTANCE OF ON-SITE CONDITIONS AS THEY EXIST.

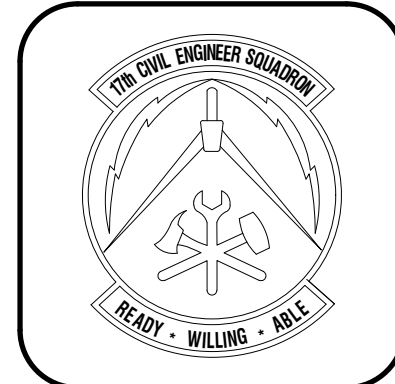

--	--	--	--	--	--	--	--

Designed by JH/MLLA	Drawn by JH/MLLA	Reviewed by RT/JH	Submitted by PCBS
------------------------	---------------------	----------------------	----------------------

PROJECT TITLE

**FIRE STATION ADD/ALTER, B3321
PROJECT NO. 1039839
17th TRAINING WING
GOODFELLOW AIR FORCE BASE, TEXAS**

Project Number: 1039839
SHEET TITLE CIVIL SYMBOLS, NOTES & ABBREVIATIONS
Date: SEP 2023

SEQ.	SHEET	OF
10	C-001	50

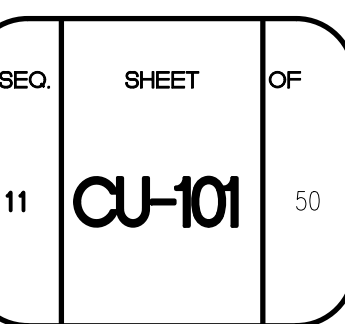
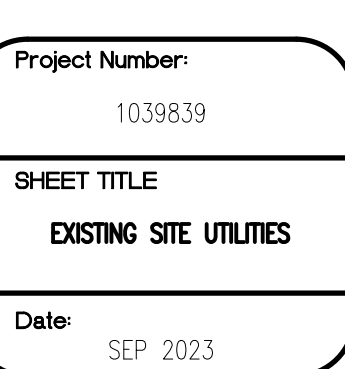
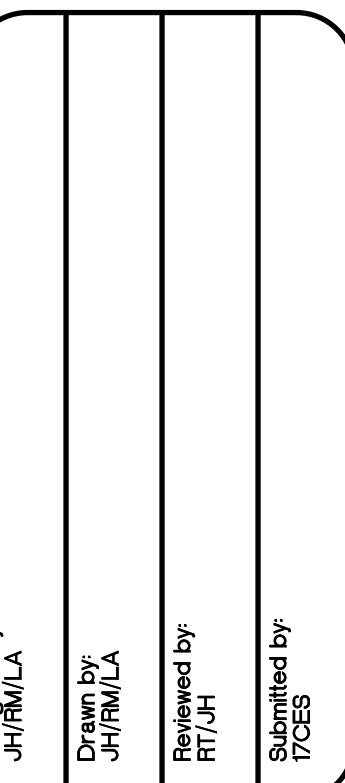
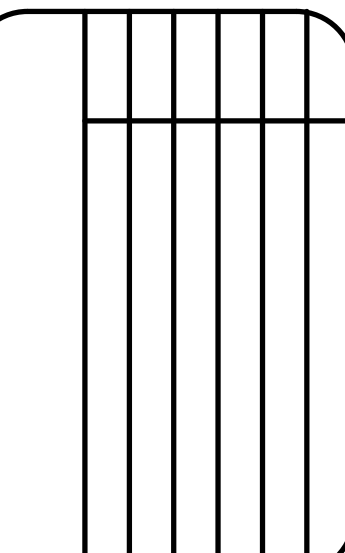
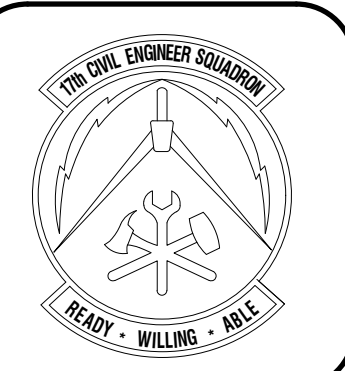

LEGEND	
SYMBOL	DESCRIPTION
— EX SS —	EXIST. SANITARY SEWER LINE
(MH)	SANITARY SEWER MANHOLE
— 36" STM —	EXIST. STORMWATER LINE
(II)	STORMWATER INLET
— EX WTR —	EXIST. DOMESTIC WATER LINE
WV	WATER VALVE
⊙	FIRE HYDRANT
— UE — UE — UE —	UNDERGROUND ELECTRIC LINE
— OE — OE — OE —	OVERHEAD ELECTRIC LINE
⚡	TRANSFORMER
— G — G — G —	GAS LINE
GV	GAS VALVE
M	METER
YCO	YARD CLEANOUT
— UC — UC —	UNDERGROUND TELECOMM.

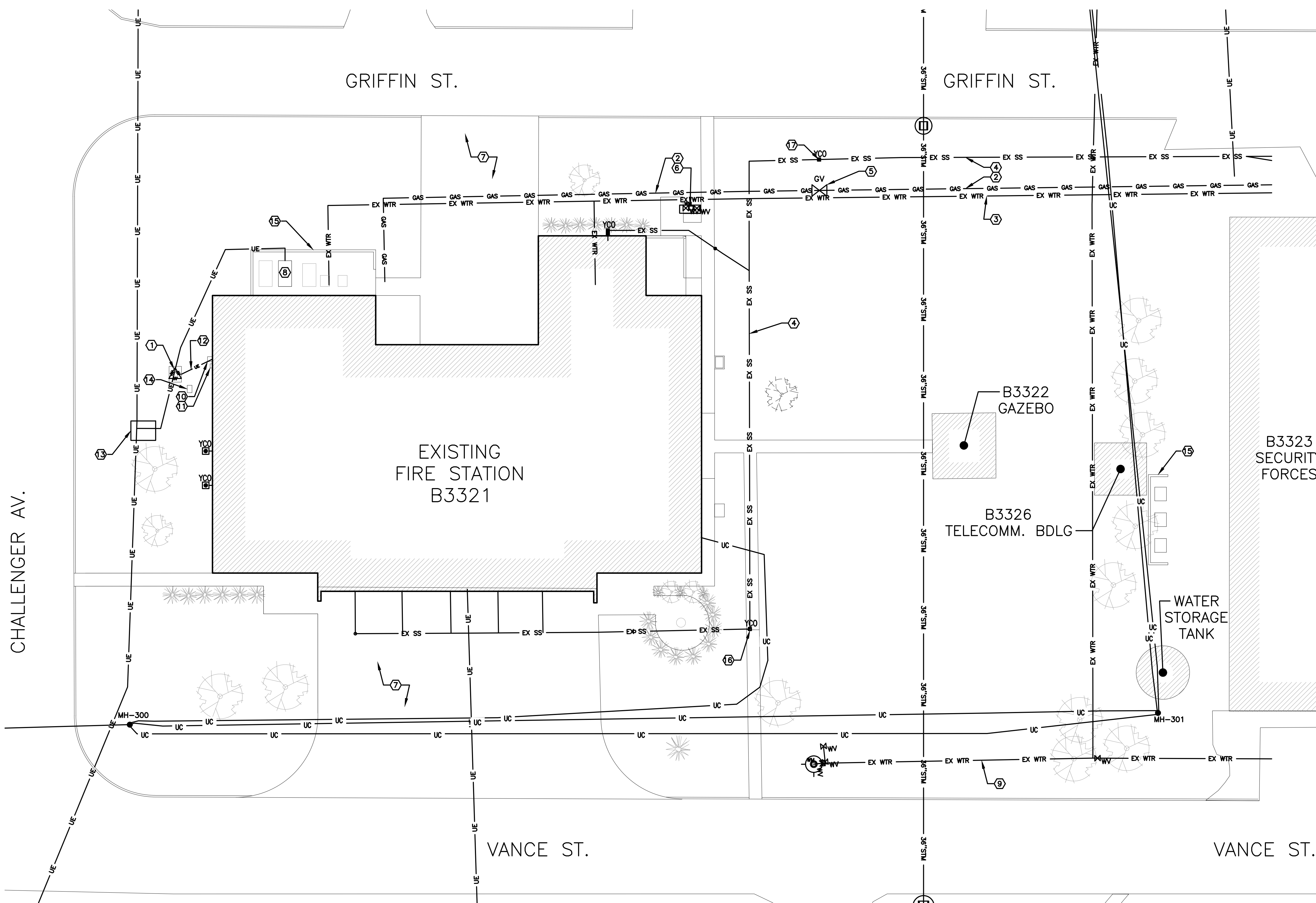

1 EXISTING BUILDING UTILITIES
1/8" = 1' - 0"

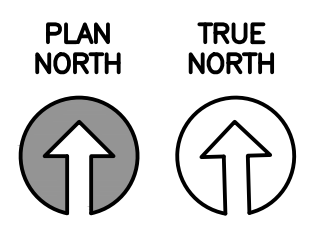

GENERAL NOTES

- ALL LABOR, MATERIALS, AND METHODS OF CONSTRUCTION SHALL BE IN STRICT ACCORDANCE WITH THE UNIFIED FACILITIES CRITERIA (UFCs) AND OTHER APPLICABLE CODES AND STANDARDS.
- THE CONTRACTOR SHALL BE REQUIRED FOR ACQUIRING AND SUBMITTING ALL REQUIRED PERMITS, INCLUDING AN AF FORM 103 "DIG REQUEST PERMIT", PRIOR TO POTHOLING, DIGGING, AND EXCAVATING THE SITE. NO CONSTRUCTION SHALL BEGIN UNTIL THE CONTRACTOR HAS RECEIVED ALL PLANS AND ANY OTHER DOCUMENTATION FROM ALL OF THE PERMITTING AND ANY OTHER REGULATORY AUTHORITIES. ANY PENALTIES, STOP WORK ORDERS OR ADDITIONAL WORK RESULTING FROM THE CONTRACTOR BEING IN VIOLATION OF THE REQUIREMENTS ABOVE, SHALL BE FULLY BORNE BY THE CONTRACTOR.
- UTILITIES SHOWN ARE BASED OFF MOST RECENT INFORMATION, AND ONLY MEANT TO ASSIST THE CONTRACTOR. THE CONTRACTOR SHALL BE RESPONSIBLE FOR VERIFYING THE EXACT LOCATION OF UTILITIES PRIOR TO START OF CONSTRUCTION. ANY DAMAGE TO EXISTING UTILITIES NOT INCLUDED IN THIS SCOPE OF WORK, REQUIRING REPAIR OR REPLACEMENT SHALL BE CORRECTED BY THE CONTRACTOR AT NO ADDITIONAL COST TO THE GOVERNMENT.
- CONTRACTOR SHALL COORDINATE LIMITS OF WORK AND LAYDOWN AREA WITH THE CONTRACTING OFFICER PRIOR TO START OF WORK.
- UTILITY OUTAGES AND DISRUPTIONS SHALL BE COORDINATED WITH THE GOV'T AND SHALL BE PERFORMED AS SPECIFIED.

- SITE WORK AREAS SHALL BE KEPT IN A CLEAN, SAFE, AND WORKMANLIKE CONDITION. DEBRIS SHALL BE CLEANED UP ON A DAILY BASIS, AND SITE SHALL BE MAINTAINED AS SPECIFIED.
- WHEN EXCAVATING, THE CONTRACTOR SHALL HAND DIG AROUND AREAS WHERE EXISTING UTILITIES ARE SUSPECTED OR INDICATED ON THESE DRAWINGS.
- REFER TO FIRE STATION AS BUILTS FOR ADDITIONAL UTILITY AND POWER INFORMATION.

KEYNOTES

- EXISTING 300 kVA PAD MOUNTED TRANSFORMER.
- EXISTING 1" - 10PSI GAS SERVICE LINE
- EXISTING 2 1/2" WATER SERVICE LINE
- EXISTING 6" SANITARY SEWER LINE
- EXISTING 1094 CFH GAS METER
- EXISTING FIRE STATION WATER METER AND SERVICE BOX
- CONCRETE APRON AND DRIVEWAY
- EXISTING FIRE STATION EMERGENCY GENERATOR
- EXISTING 6" WATER SERVICE LINE TO FIRE HYDRANT
- EXISTING MAIN DISCONNECT
- EXISTING ELECTRIC METER
- PRIMARY SERVICE LINE. 3-#4/0 CU 15 KV IN 4" C & 4" C SPARE, CONCRETE ENCASED.
- EXISTING ELECTRICAL MANHOLE AND ENCLOSURE MH-DB
- EXISTING C-TV BOX
- EXISTING EXTERIOR MECHANICAL ENCLOSURE
- EXISTING YARD CLEANOUT, FL = 1858.67'
- EXISTING YARD CLEANOUT, FL = 1856.56'

CI

GRIFFIN ST.

GRIFFIN ST.

CHALLENGER AV.

EXISTING FIRE STATION B3321
FINISH FLOOR = 1862.00'

FINISH FLOOR = 1862.00'

B3322 GAZEBO

B3326 TELECOMM. BDLG

B3323 SECURITY FORCES

WATER STORAGE TANK

VANCE ST.

VANCE ST.

LEGEND:

- 1859.12' EXISTING SPOT ELEVATIONS
- - 1860.00' - - EXISTING CONTOURS
- 1860.00' — NEW CONTOURS
- NEW BUILDING
- EXISTING BUILDING
- NEW CONCRETE SURFACE

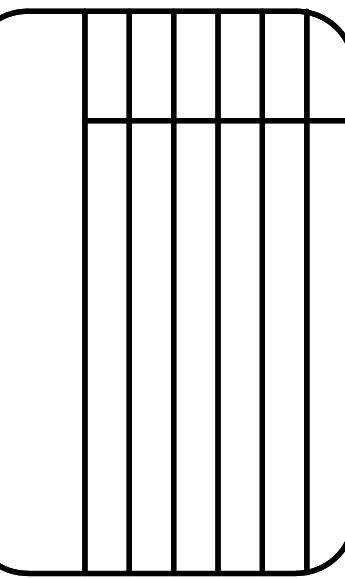
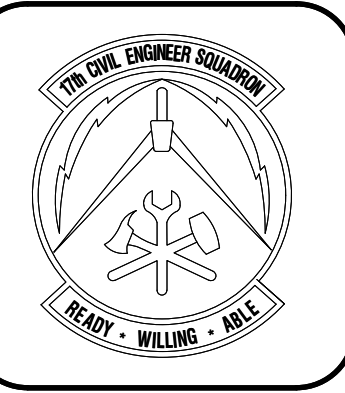

Designed by
JHR/LA

Drawn by
JHR/LA

Reviewed by
RTI/JH

Submitted by
PCBS

PROJECT TITLE

FIRE STATION ADD/ALTER, B3321
PROJECT NO. 1039839
17th TRAINING WING
GOODFELLOW AIR FORCE BASE, TEXAS

Project Number:
1039839

SHEET TITLE
SITE CONTOURS

Date:
SEP 2023

SEQ. SHEET OF

12 CG-101 50

1 SITE GRADING PLAN
1/8" = 1' - 0"

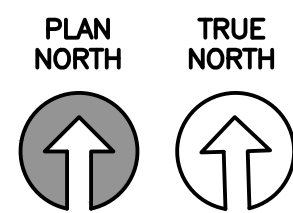

GENERAL SITE NOTES:

1. CONTRACTOR SHALL VERIFY NEW GRADES WITH THE PROJECT MANAGER TO ENSURE POSITIVE DRAINAGE AWAY FROM THE NEW BUILDING.
2. PROVIDE ELECTRICAL SERVICE TO ALL NEW EXTERIOR ELECTRICAL ITEMS, AS REQUIRED.
3. REFERENCE MECHANICAL, PLUMBING AND ELECTRICAL DRAWINGS FOR EXTERIOR WORK AND INTERIOR CONTINUATIONS.
4. CONTRACTOR SHALL COORDINATE WORK WITH ALL OTHER TRADES FOR EXTERIOR AND INTERIOR CONTINUATIONS.
5. SITE PLAN DIMENSIONS WITHIN () ARE APPROXIMATE.
6. LOCATION OF EXISTING ITEMS OUTSIDE OF PROJECT SITE ARE APPROXIMATE AND ARE FOR REFERENCE ONLY.
7. PROVIDE TOPSOIL AND HYDROMULCH AS INDICATED.
8. NEW CONCRETE SIDEWALKS SHALL BE FIBER REINFORCED CONCRETE.
9. FOR SIDEWALK CONCRETE EXPANSION JOINT SEE SHEET C-501, DETAIL #2

DUST:

1. TAKE PRECAUTIONS NECESSARY TO PREVENT DUST NUISANCE, BOTH ON-SITE AND ADJACENT BUILDINGS. CORRECT OR REPAIR DAMAGE CAUSED BY DUST.

EROSION CONTROL:

1. TAKE PRECAUTIONS NECESSARY TO PREVENT EROSION AND TRANSPORTATION OF SOIL DOWNSTREAM, TO ADJACENT PROPERTIES AND INTO ON-SITE AND OFF-SITE DRAINAGE SYSTEMS. THE CONTRACTOR AND SUBCONTRACTORS SHALL BE RESPONSIBLE FOR MEETING THE REQUIREMENTS OF THE TPDES GENERAL PERMIT #TXR150000 AND SHALL PREPARE A "STORM WATER POLLUTION PREVENTION PLAN" WHERE REQUIRED AND ADHERE TO THE REQUIREMENTS SET FORTH THEREIN. THE CONTRACTOR SHALL PROVIDE THE PROJECT MANAGER AND GOV'T WITH COPIES OF ALL DOCUMENTS ASSOCIATED WITH THE PLAN.

SPILLAGE:

1. AVOID SPILLAGE BY COVERING AND SECURING LOADS WHEN HAULING ON OR ADJACENT TO PUBLIC STREETS OR HIGHWAYS. REMOVE SPILLAGE AND SWEEP, WASH OR OTHERWISE CLEAN PROJECT, STREET AND HIGHWAYS.

EXISTING PLANTS AND FEATURES:



1. DO NOT DAMAGE TOPS, TRUNKS AND ROOTS OF EXISTING TREES AND/OR SHRUBS THAT ARE INTENDED TO REMAIN. DO NOT USE HEAVY EQUIPMENT WITHIN BRANCH SPREAD. INTERFERING BRANCHES MAY BE REMOVED ONLY WITH THE PERMISSION OF THE PROJECT MANAGER. DO NOT DAMAGE PLANTS AND FEATURES THAT ARE TO REMAIN.

DIG TESS:

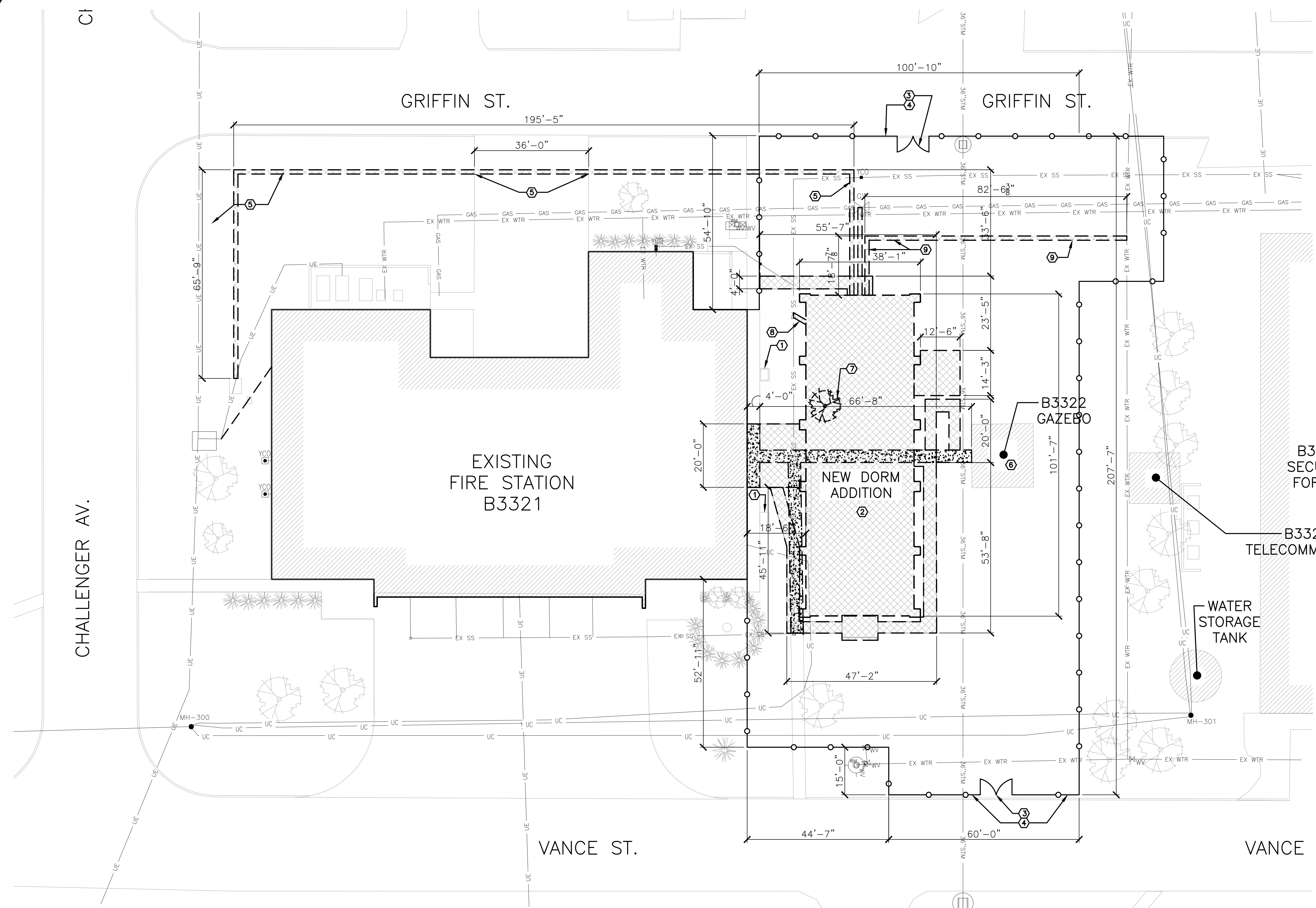
1. CONTRACT DIG TESS TO ARRANGE FOR UTILITY LOCATIONS WHERE REQUIRED.

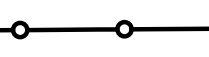

LEGEND

-  DEMO AREA
-  TEMPORARY FENCING
-  EXISTING FACILITY
-  EXISTING CONCRETE SIDEWALK DEMO

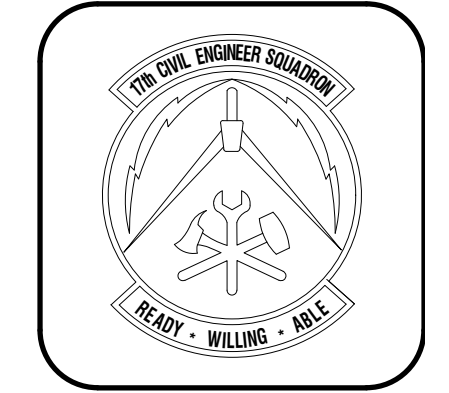

Designed by JH/MLLA	Drawn by JH/MLLA	Reviewed by RT/JAH	Submitted by PC/ES
------------------------	---------------------	-----------------------	-----------------------

PROJECT TITLE
FIRE STATION ADD/ALTER, B3321
PROJECT NO. 1039839
17th TRAINING WING
GOODFELLOW AIR FORCE BASE, TEXAS

Project Number: 1039839
SHEET TITLE SITE DEMO
Date: SEP 2023

SEQ.	SHEET	OF
13	CD-101	50

1 SITE GRADING PLAN
 $\frac{1}{16}'' = 1' - 0''$

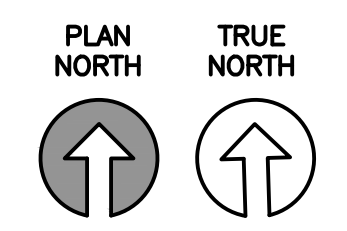

KEYNOTES AS INDICATED BY (X)

1. EXISTING A/C UNITS AND PAD TO REMAIN. CONTRACTOR SHALL PROTECT FROM DAMAGE.
2. NEW BUILDING FOOTPRINT. CONTRACTOR SHALL EXCAVATE EARTHWORK AND FILL AS SPECIFIED.
3. PROPOSED CONTRACTOR ENTRY/EXIT. CONTRACTOR SHALL SAW CUT AND REPLACE CURB AS NEEDED FOR MATERIAL AND EQUIPMENT SHIPMENTS. CONTRACTOR SHALL PROVIDE TEMPORARY ROCK STABILIZED CONSTRUCTION ENTRANCE OR CONTROL MATS. CONTRACTOR SHALL ENSURE CONSTRUCTION DEBRIS ON VANCE ST. OR GRIFFIN ST. IS CLEANED DAILY AS SPECIFIED OR AS DIRECTED BY CO.
4. CONTRACTOR SHALL PROVIDE TEMPORARY FENCING AROUND WORKSITE AS INDICATED. DUE TO HIGH WINDS EXPERIENCED IN WORK AREA, THE CONTRACTOR SHALL PROVIDE SAND BAGS OR WEIGHTS ON ALL POSTS. CONTRACTOR SHALL PROVIDE GOVERNMENT ACCESS TO FIRE HYDRANTS AT ALL TIMES.
5. CONTRACTOR SHALL TRENCH AND REMOVE FILL FOR NEW ELECTRICAL WIRING AND CONDUIT. CONTRACTOR SHALL HORIZONTALLY BORE UNDERNEATH EXISTING CONCRETE DRIVEWAY. CONTRACTOR SHALL PROVIDE HIGH VISIBILITY SIGNAGE AS SPECIFIED. CONTRACTOR SHALL BE RESPONSIBLE FOR RESTORING DISTURBED AREAS UPON COMPLETION OF WORK.
6. EXISTING GAZEBO TO REMAIN. CONTRACTOR SHALL PROTECT.
7. CONTRACTOR SHALL DEMO EXISTING TREE.
8. CONTRACTOR SHALL TRENCH AND EXCAVATE EARTHWORK FOR NEW SANITARY SEWER CONNECTION. CONTRACTOR SHALL TIE INTO EXISTING 6" SANITARY SEWER LINE ONCE NEW SEWER LINE IS READY TO CONNECT.
9. CONTRACTOR SHALL TRENCH AND EXCAVATE EARTHWORK FOR NEW DOMESTIC WATER/GAS SERVICE LINES. CONTRACTOR SHALL TIE INTO EXISTING WATER/GAS LINES ONCE NEW SERVICE IS READY TO CONNECT. CONTRACTOR SHALL DEMO EXISTING GAS METER AND PROVIDE NEW AS INDICATED.

GENERAL NOTES:

1. THE CONTRACTOR SHALL BE RESPONSIBLE FOR VERIFYING EXISTING CONDITIONS, EQUIPMENT, AND DIMENSIONS PRIOR TO START OF WORK.
2. CONTRACTOR SHALL ENSURE TO PROTECT ITEMS INDICATED AS "EXISTING TO REMAIN". ANY DAMAGE TO ITEMS OR BUILDING ELEMENTS OUTSIDE THE SCOPE OF WORK REQUIRING REPAIR OR REPLACEMENT SHALL BE PERFORMED BY THE CONTRACTOR AT NO ADDITIONAL COST TO THE GOVERNMENT.
3. THE CONTRACTOR SHALL COORDINATE WORK WITH ALL OTHER TRADES.
4. CONTRACTOR SHALL PROVIDE EROSION AND SEDIMENT CONTROL DEVICES FOR ALL STORM DRAINAGE INLETS AND SILT FENCES AS SPECIFIED AND INDICATED IN GENERAL 001, 002, AND G003. REFER TO C-501 FOR EROSION CONTROL DETAILS.
5. REFER TO CU-101 FOR SITE UTILITIES LEGEND.
6. CONTRACTOR SHALL COORDINATE ALL UTILITY OUTAGES WITH THE GOVERNMENT AS SPECIFIED. CONTRACTOR SHALL ENSURE ALL NEW UTILITY WORK IS COMPLETED PRIOR TO DEMOLISHING OR CONNECTING TO EXISTING LINES.

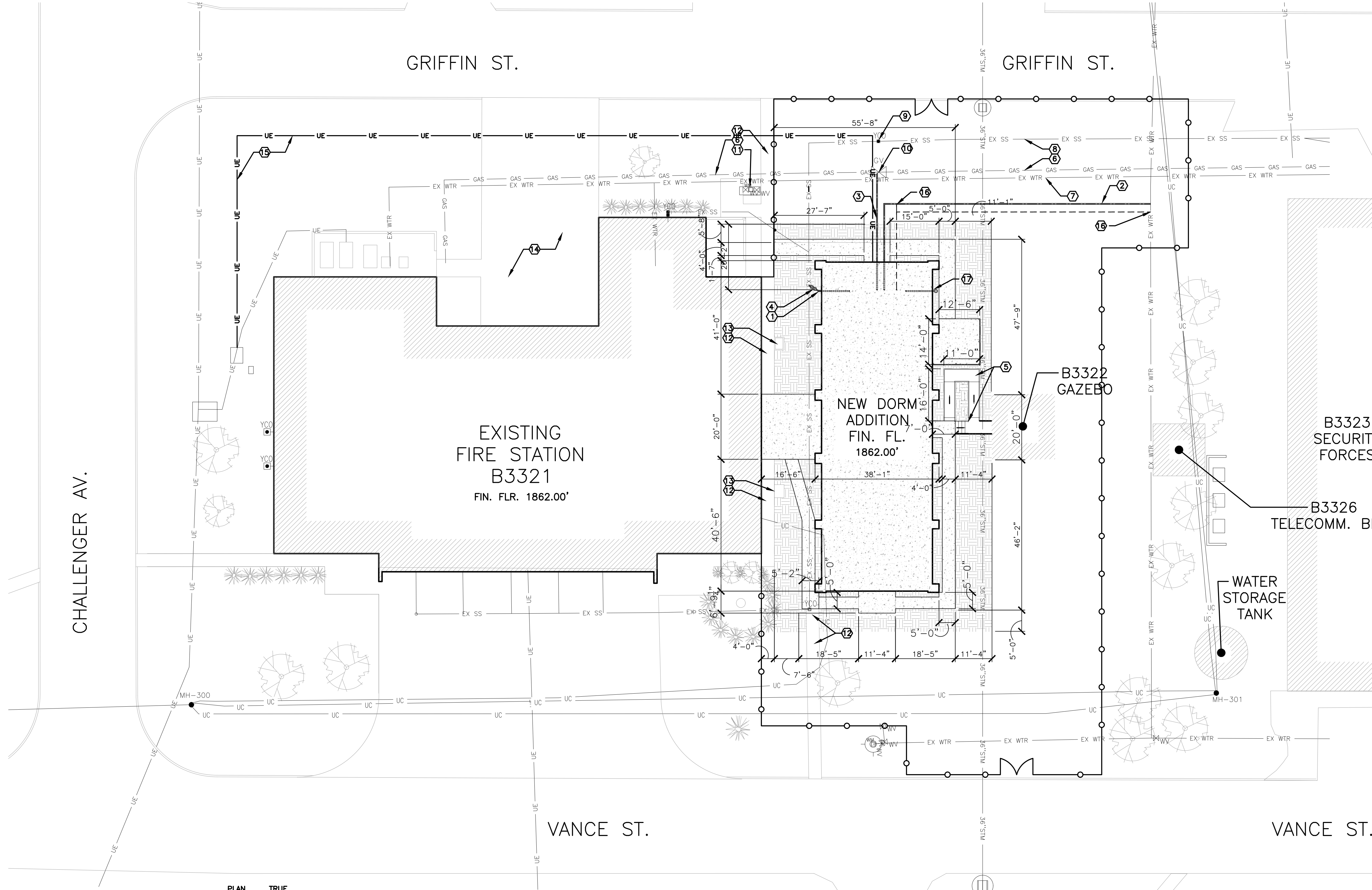

- LEGEND**
- HYDROMULCHED AREA
 - TEMPORARY FENCING
 - EXISTING FACILITY
 - NEW CONCRETE SIDEWALK DEMO

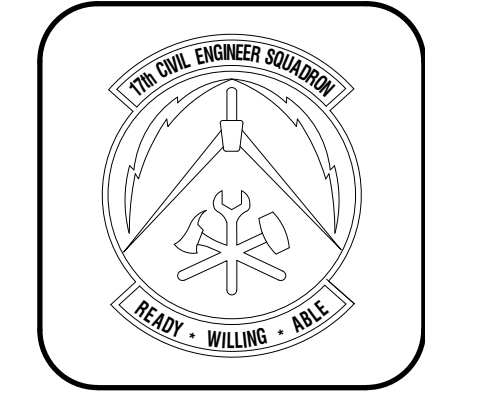

Designed by JH/MLLA	Drawn by JH/MLLA	Reviewed by RT/JH	Submitted by PCBS
------------------------	---------------------	----------------------	----------------------

PROJECT TITLE
 FIRE STATION ADD/ALTER, B3321
 PROJECT NO. 1039839
 17th TRAINING WING
 GOODFELLOW AIR FORCE BASE, TEXAS

① **NEW SITE PLAN**
 $\frac{1}{16}'' = 1' - 0''$

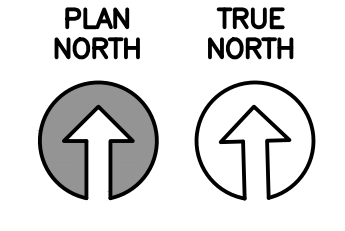

- KEYNOTES AS INDICATED BY**
1. CONTRACTOR SHALL PROVIDE NEW 4" SANITARY SEWER LATERAL OUTSIDE OF BUILDING TO CONNECT TO EXISTING 6" SANITARY SEWER LINE. REFER TO PLUMBING FOR ADDITIONAL INFORMATION
 2. CONTRACTOR SHALL TAP INTO EXISTING 8" WATER MAIN. PROVIDE NEW 1 1/2" DOMESTIC WATER SERVICE LINE. PROVIDE NEW SERVICE CONNECTION AND ACCESS BOX AT CONNECTION POINT.
 3. NEW 1" GAS SERVICE LINE. PROVIDE NEW GAS METER ASSEMBLY, REGULATOR, AND CUTOFF VALVE. FOR EXTERIOR NATURAL GAS SERVICE, PROVIDE POLYETHYLENE PIPING AS SPECIFIED.
 4. NEW TWO-WAY CLEANOUT RE:1/C501
 5. NEW CONCRETE ADA COMPLIANT RAMP AND STAIRCASE. PROVIDE NEW ANODIZED ALUMINUM HANDRAILS WITH DK. BRONZE FINISH. RE: ARCHITECTURAL
 6. EXISTING 1" -10PSI GAS LINE
 7. EXISTING 2 1/2" WATER SERVICE LINE
 8. EXISTING 6" SANITARY SEWER LINE
 9. EXISTING GROUND CLEANOUT FL = 1865.56
 10. EXISTING 1094 CFH GAS METER
 11. EXISTING FIRE STATION WATER METER AND SERVICE BOX
 12. EXISTING CONCRETE SIDEWALK TO REMAIN.
 13. EXISTING A/C UNITS AND PAD TO REMAIN. CONTRACTOR SHALL PROTECT.
 14. EXISTING FIRE STATION DRIVEWAYS

15. NEW ELECTRIC SERVICE LINE AND CONDUIT
16. CONTRACTOR SHALL PROVIDE NEW DEDICATED WATER SERVICE FOR FIRE SUPPRESSION SYSTEM. SERVICE MAY BE TAPPED SEPARATELY FROM DOMESTIC WATER AS DETERMINED BY QFPE. REFER TO FA-101. REFER TO GAFB BASE STANDARDS FOR TYP. PIPE MATERIAL REQUIREMENTS.
17. CONTRACTOR TO PROVIDE NEW YARD CLEANOUT.

GENERAL NOTES:

1. THE CONTRACTOR SHALL BE RESPONSIBLE FOR VERIFYING EXISTING CONDITION, EQUIPMENT, ELEVATIONS, AND DIMENSIONS PRIOR TO START OF WORK.
2. CONTRACTOR SHALL ENSURE TO PROTECT ITEMS INDICATED AS "EXISTING TO REMAIN". ANY DAMAGE TO ITEMS OR BUILDING ELEMENTS OUTSIDE THE SCOPE OF WORK WILL BE REPLACED OR REPAIRED BY THE CONTRACTOR AT NO ADDITIONAL COST TO THE GOVERNMENT.
3. THE CONTRACTOR SHALL COORDINATE WORK WITH ALL OTHER TRADES.
4. REFER TO CU-101 FOR SITE UTILITIES.
5. CONTRACTOR SHALL TAKE NECESSARY PRECAUTIONS TO PREVENT EROSION AND TRANSPORTATION OF SOIL DOWNSTREAM, TO ADJACENT PROPERTIES AND INTO ON-SITE OR OFF-SITE DRAINAGE SYSTEMS. THE CONTRACTOR AND SUBCONTRACTORS SHALL BE RESPONSIBLE FOR MEETING THE REQUIREMENTS OF THE TPDES GENERAL PERMIT #TXR150000 AND SHALL PREP ARE A "STORM WATER POLLUTION PREVENTION PLAN" WHERE REQUIRED AND ADHERE TO THE REQUIREMENTS SET FORTH THEREIN. THE

CONTRACTOR SHALL PROVIDE THE PROJECT MANAGER AND GOVT. WITH COPIES OF ALL DOCUMENTS ASSOCIATED WITH THE PLAN.

6. FOR SANITARY SEWER LATERALS OUTSIDE OF FACILITY CONTRACTOR SHALL PROVIDE PVC AS SPECIFIED.
7. FOR WATER SERVICE LINES 3" IN DIAMETER AND SMALLER, CONTRACTOR SHALL PROVIDE PVC RATED PIPING FOR DOMESTIC WATER USE AS SPECIFIED.

Project Number: 1039839
SHEET TITLE SITE NEW
Date: SEP 2023

SEQ. 14	SHEET C-101	OF 50
------------	-----------------------	----------

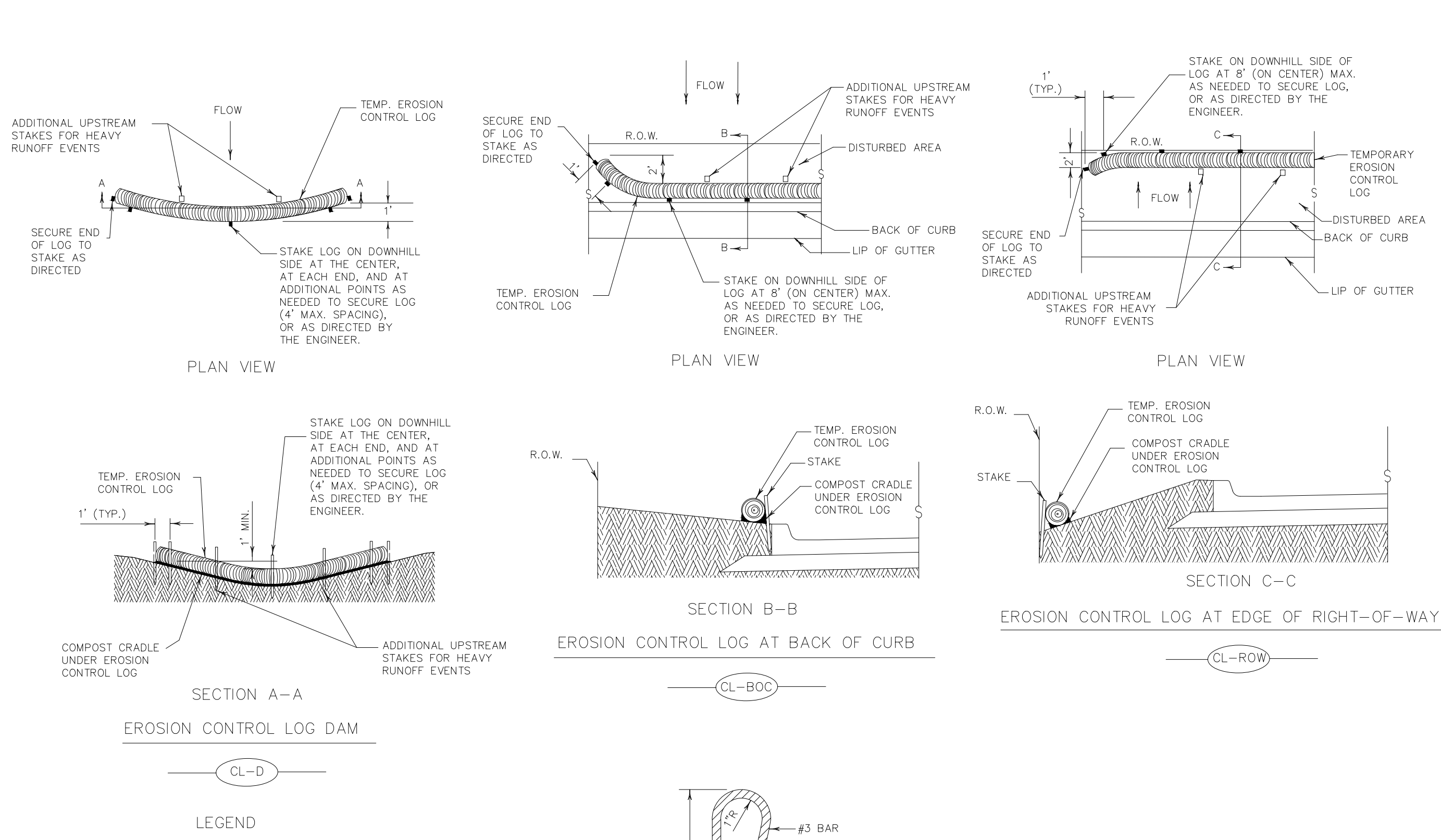
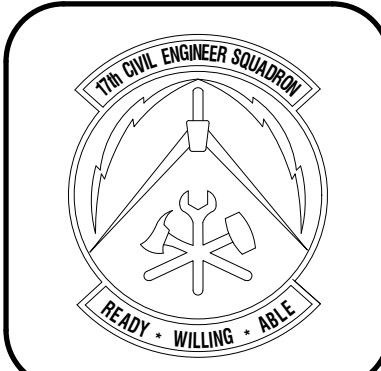

- LEGEND**
- CL-D EROSION CONTROL LOG DAM
 - CL-BOC EROSION CONTROL LOG AT BACK OF CURB
 - CL-ROW EROSION CONTROL LOG AT EDGE OF RIGHT-OF-WAY
 - CL-SST EROSION CONTROL LOGS ON SLOPES STAKE AND TRENCHING ANCHORING
 - CL-SSL EROSION CONTROL LOGS ON SLOPES STAKE AND LASHING ANCHORING
 - CL-DI EROSION CONTROL LOG AT DROP INLET
 - CL-CI EROSION CONTROL LOG AT CURB INLET
 - CL-GI EROSION CONTROL LOG AT CURB & GRATE INLET

SEDIMENT BASIN & TRAP USAGE GUIDELINES

An erosion control log sediment trap may be used to filter sediment out of runoff draining from an unstabilized area.

Log Traps: The drainage area for a sediment trap should not exceed 5 acres. The trap capacity should be 1800 CF/Acre (0.5" over the drainage area).

Control logs should be placed in the following locations:

1. Within drainage ditches spaced as needed or min. 500' on center
2. Immediately preceding ditch inlets or drain inlets
3. Just before the drainage enters a water course
4. Just before the drainage leaves the right of way
5. Just before the drainage leaves the construction limits where drainage flows away from the project.

The logs should be cleaned when the sediment has accumulated to a depth of 1/2 the log diameter.

Cleaning and removal of accumulated sediment deposits is incidental and will not be paid for separately.

GENERAL NOTES:

1. EROSION CONTROL LOGS SHALL BE INSTALLED IN ACCORDANCE WITH MANUFACTURER'S RECOMMENDATIONS, OR AS DIRECTED BY THE ENGINEER.
2. LENGTHS OF EROSION CONTROL LOGS SHALL BE IN ACCORDANCE WITH MANUFACTURER'S RECOMMENDATIONS AND AS REQUIRED FOR THE PURPOSE INTENDED.
3. UNLESS OTHERWISE DIRECTED, USE BIODEGRADABLE OR PHOTODEGRADABLE CONTAINMENT MESH ONLY WHERE LOG WILL REMAIN IN PLACE AS PART OF A VEGETATIVE SYSTEM. FOR TEMPORARY INSTALLATIONS, USE RECYCLABLE CONTAINMENT MESH. FILL LOGS WITH SUFFICIENT FILTER MATERIAL TO ACHIEVE THE MINIMUM COMPACTED DIAMETER SPECIFIED IN THE PLANS WITHOUT EXCESSIVE DEFORMATION.
4. STAKES SHALL BE 2" X 2" WOOD OR #3 REBAR, 2'-4" LONG, EMBEDDED SUCH THAT 2" PROTRUDES ABOVE LOG, OR AS DIRECTED BY THE ENGINEER.
5. DO NOT PLACE STAKES THROUGH CONTAINMENT MESH.
6. COMPOST CRADLE MATERIAL IS INCIDENTAL & WILL NOT BE PAID FOR SEPARATELY.
7. SANDBAGS USED AS ANCHORS SHALL BE PLACED ON TOP OF LOGS & SHALL BE OF SUFFICIENT SIZE TO HOLD LOGS IN PLACE.
8. TURN THE ENDS OF EACH ROW OF LOGS UPSLOPE TO PREVENT RUNOFF FROM FLOWING AROUND THE LOG.
9. FOR HEAVY RUNOFF EVENTS, ADDITIONAL UPSTREAM STAKES MAY BE NECESSARY TO KEEP LOG FROM FOLDING IN ON ITSELF.

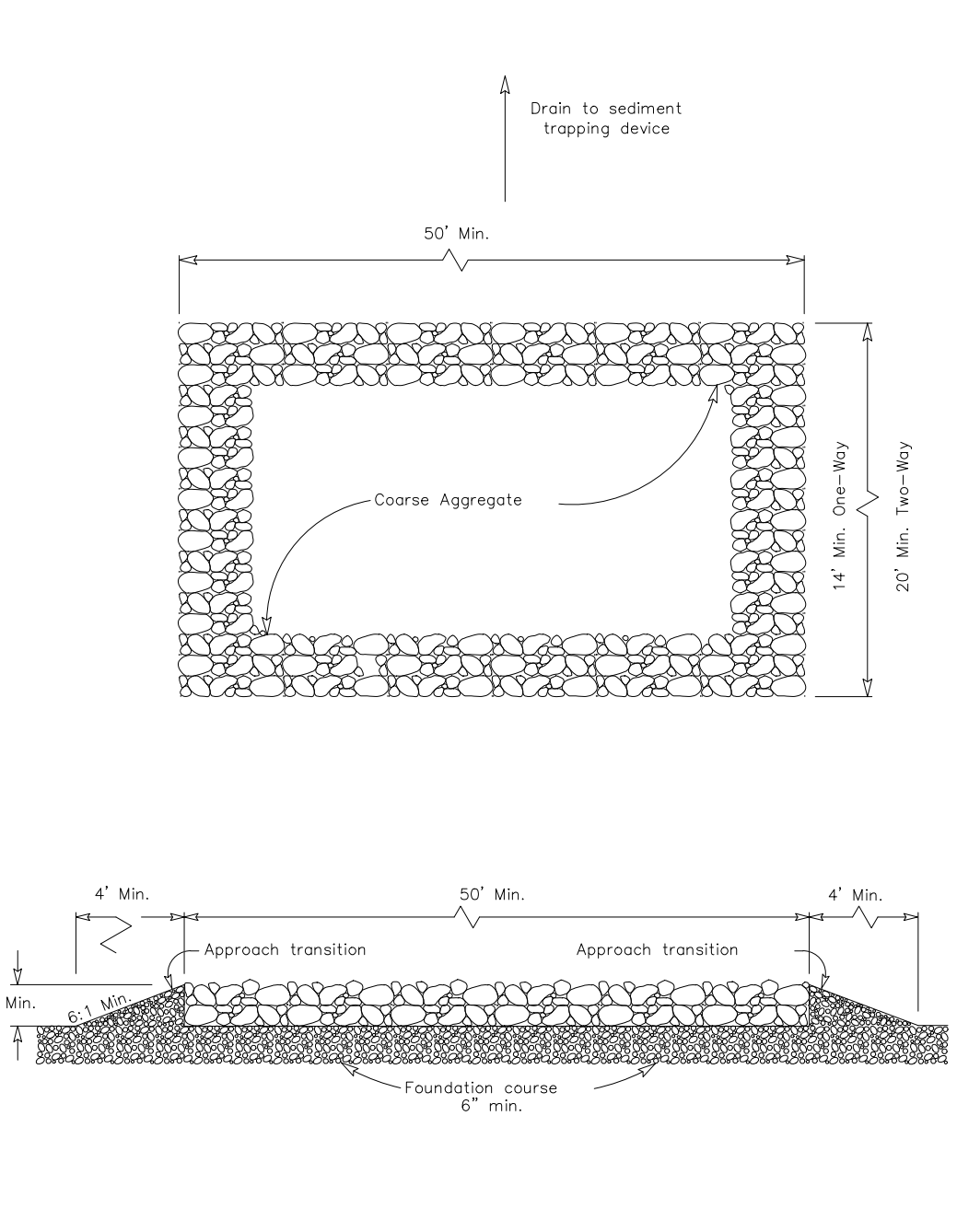
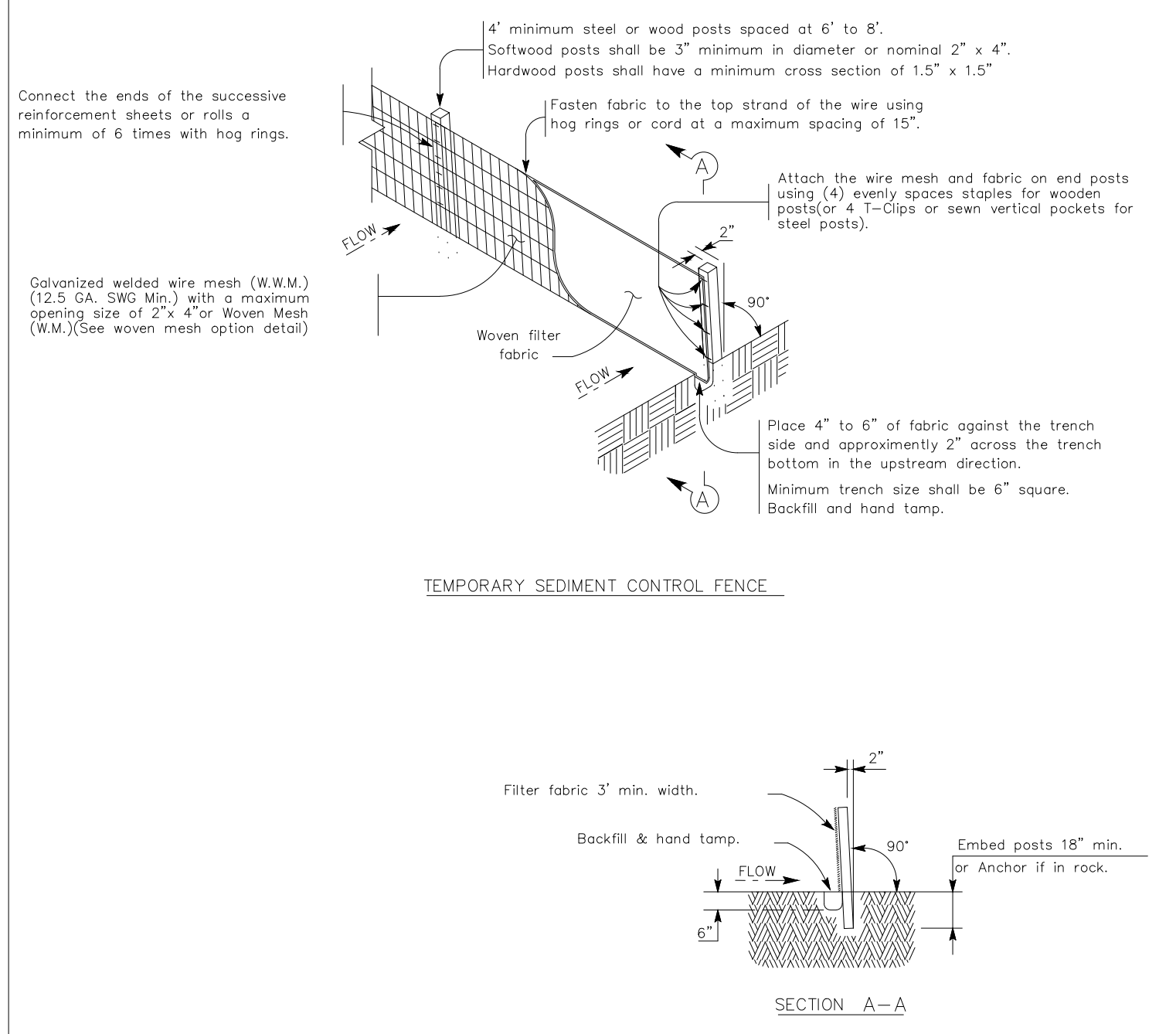
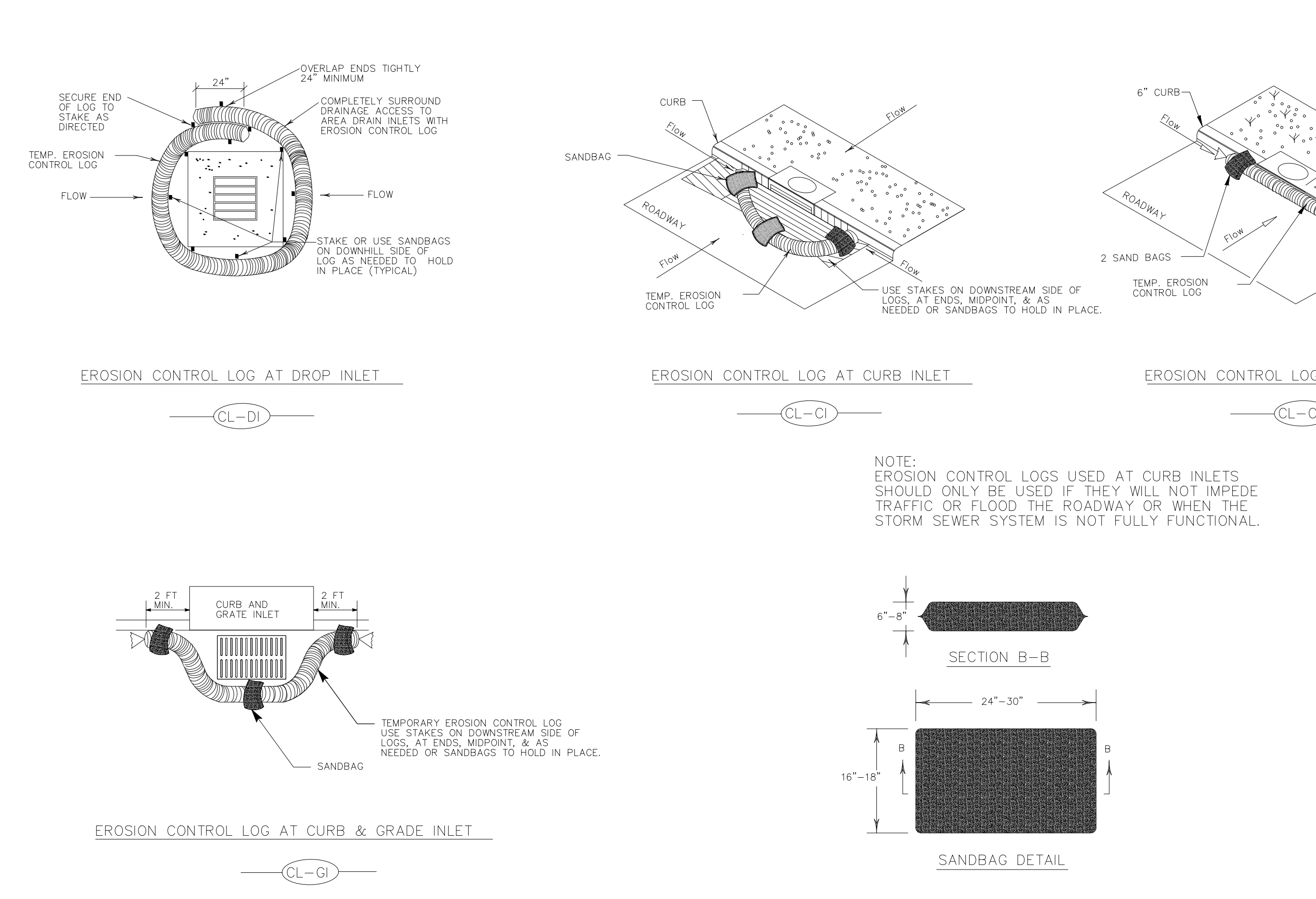
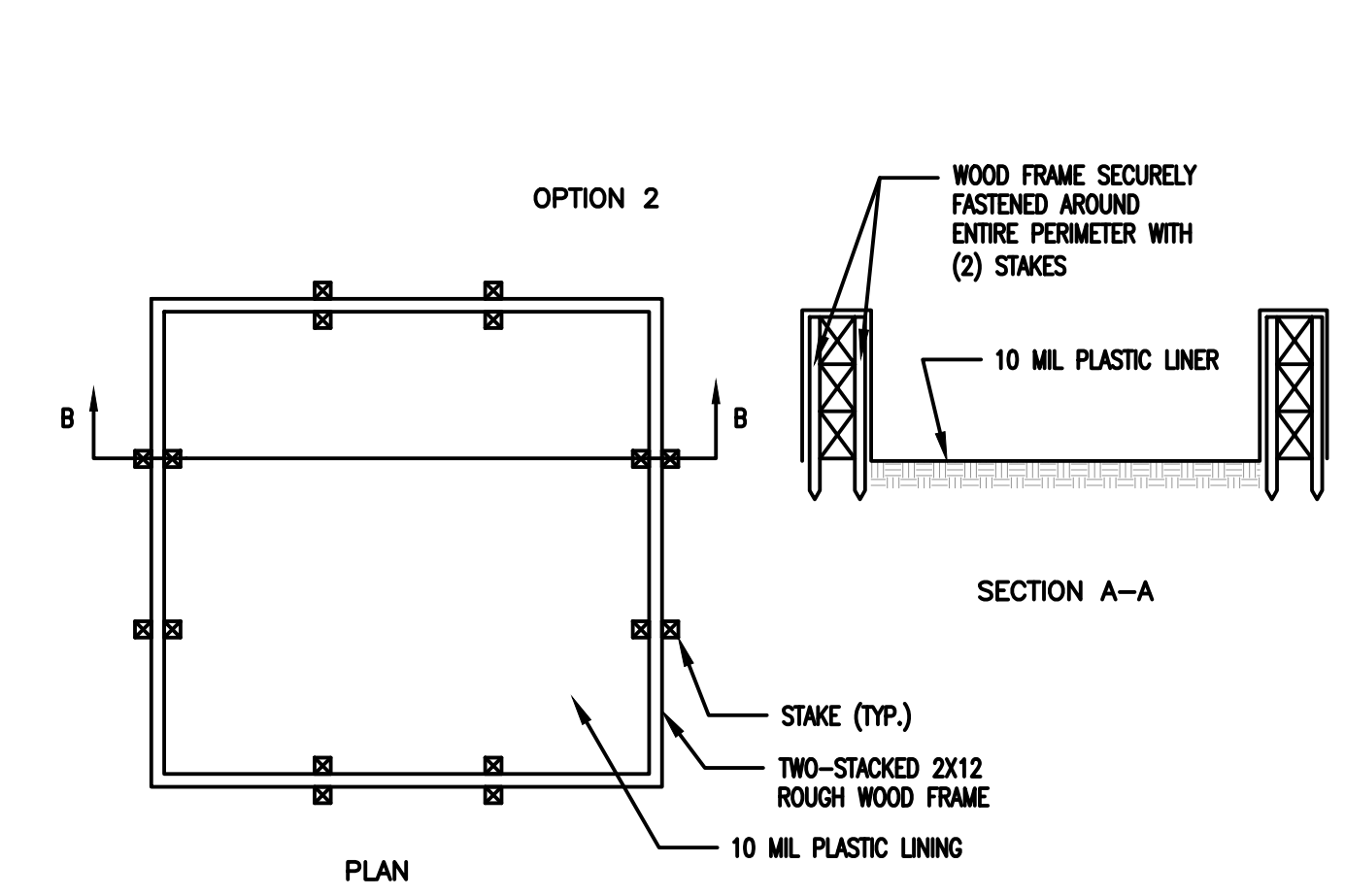
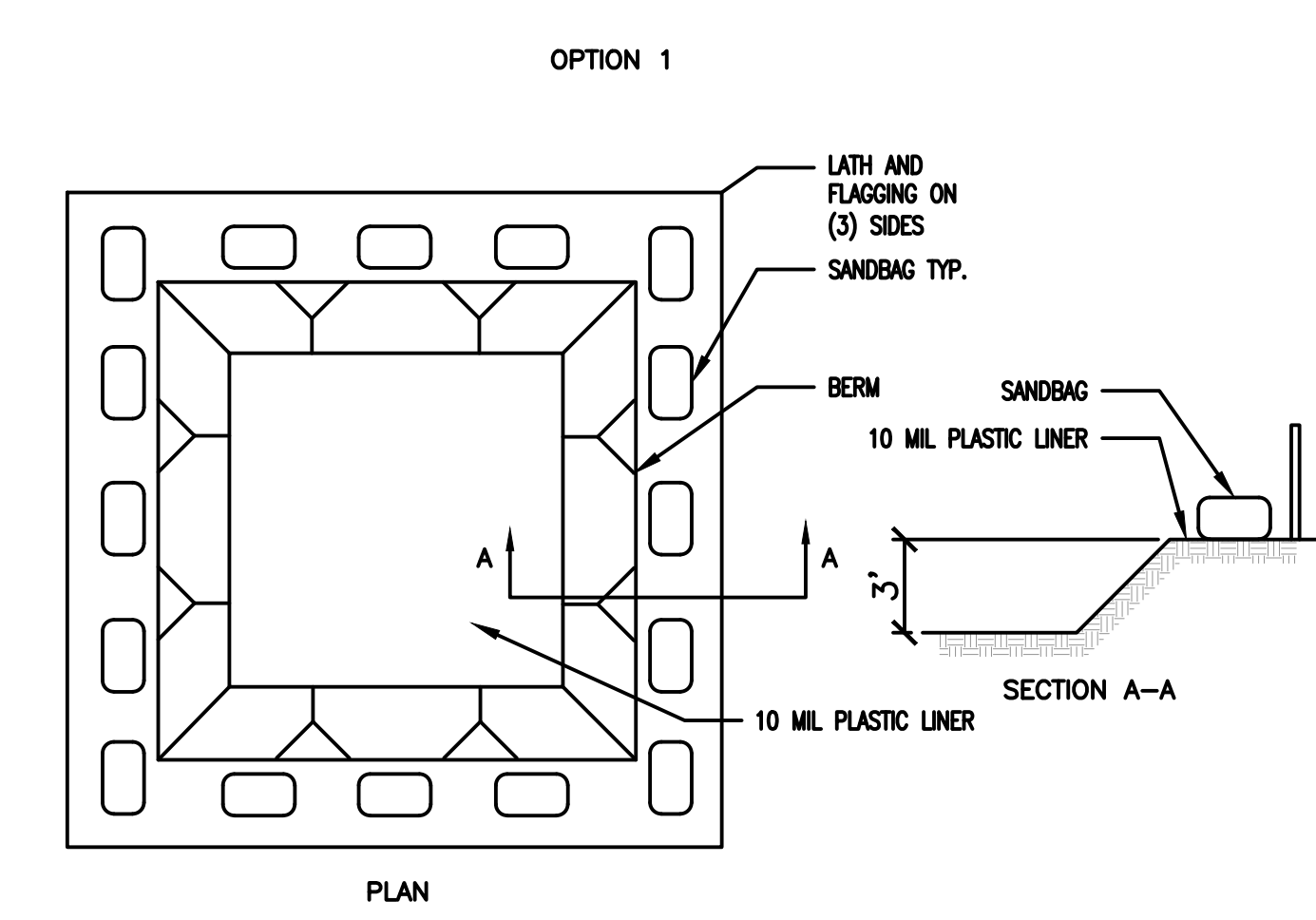
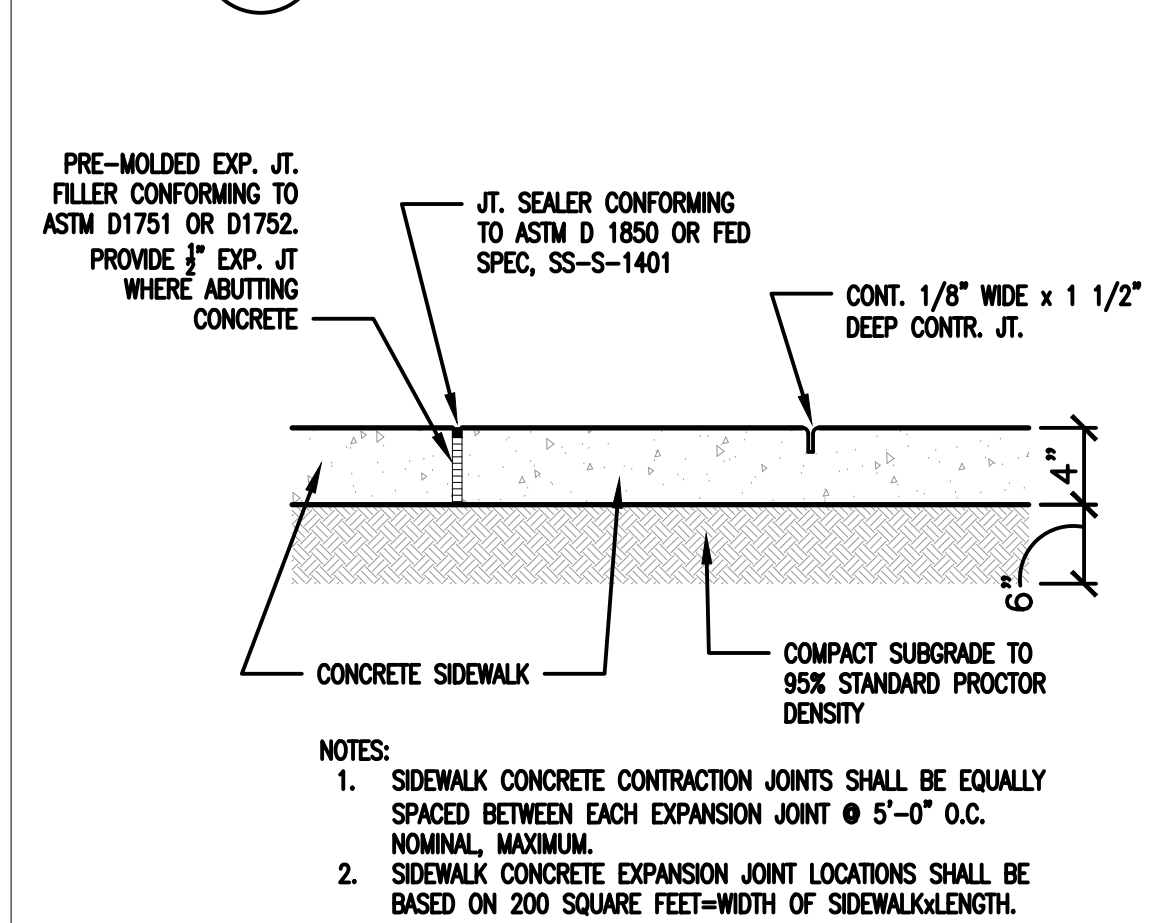
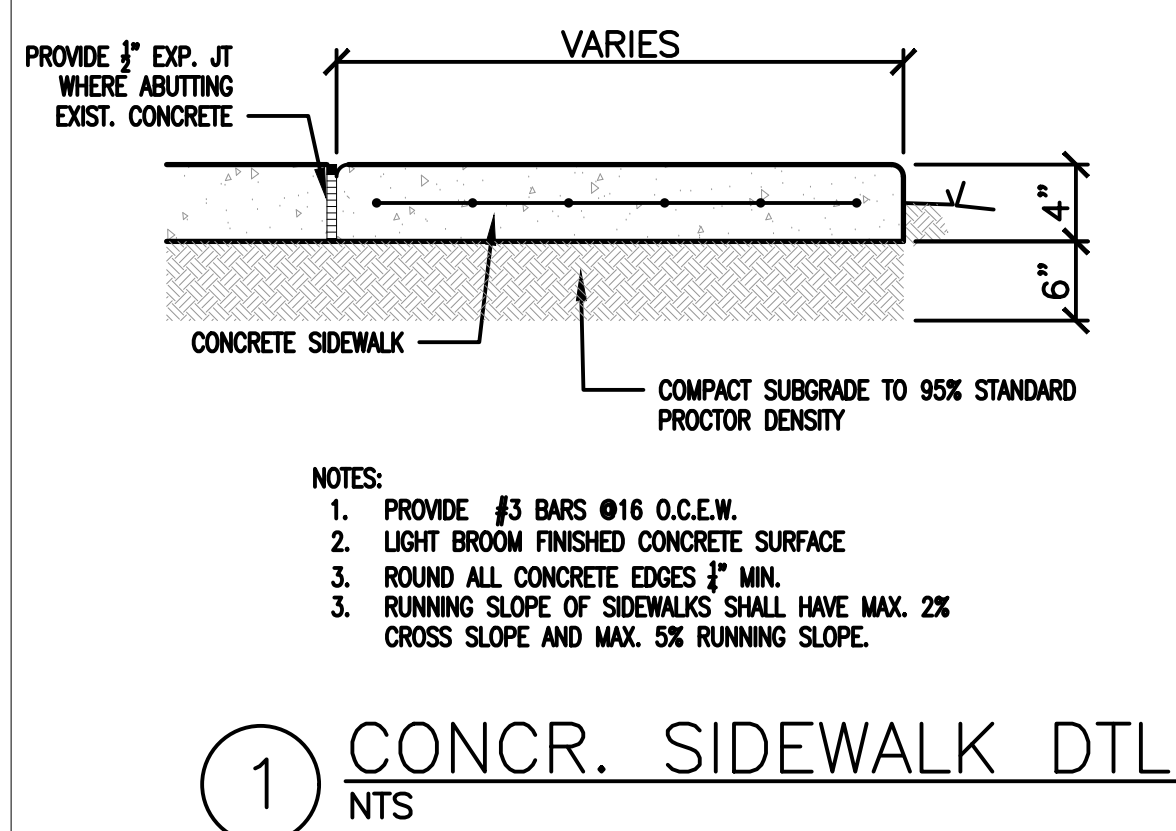

SEDIMENT CONTROL FENCE USAGE GUIDELINES

A sediment control fence may be constructed near the downstream perimeter of a disturbed area along a contour to intercept sediment from overland runoff. A 2 year storm frequency may be used to calculate the flow rate to be filtered.

Sediment control fence should be sized to filter a maximum flow through rate of 100 GPM/FT. Sediment control fence is not recommended to control erosion from a drainage area larger than 2 acres.

LEGEND
 Sediment Control Fence
 SCF

GENERAL NOTES (TYPE 1)

1. The length of the type 1 construction exit shall be as indicated on the plans, but not less than 50'.
2. The coarse aggregate should be open graded with a size of 4" to 8".
3. The approach transitions should be no steeper than 6:1 and constructed as directed by the Engineer.
4. The construction exit foundation course shall be flexible base, bituminous concrete, portland cement concrete or other materials approved by the Engineer.
5. The construction exit shall be graded to allow drainage to a sediment trapping device.
6. The guidelines shown hereon are suggestions only and may be modified by the Engineer.
7. Construct exits with a width of at least 14 ft. for one-way and 20 ft. for two-way traffic for the full width of the exit, or as directed by the engineer.

4 EROSION CONTROL DTLs.
 SCALE: NTS

SHEET 3 OF 3

Texas Department of Transportation
 Design Division Standard

TEMPORARY EROSION, SEDIMENT AND WATER POLLUTION CONTROL MEASURES
 EROSION CONTROL LOG
 EC(9)-16

FILE: ec916 DR: T2007 DW: RW DW: LS/PT DR: LS
 DATE: JULY 2016 CONT: 2021 JOB: HIGHWAY
 COUNTY: SHEET NO.

PROJECT TITLE
 FIRE STATION ADD/ALTER, B3321
 PROJECT NO. 1039839
 17th TRAINING WING
 GOODFELLOW AIR FORCE BASE, TEXAS

Project Number
 1039839

SHEET TITLE
 SITE DETAILS

Date
 SEP 2023

SEQ.
 15

SHEET
 C-501

OF
 50

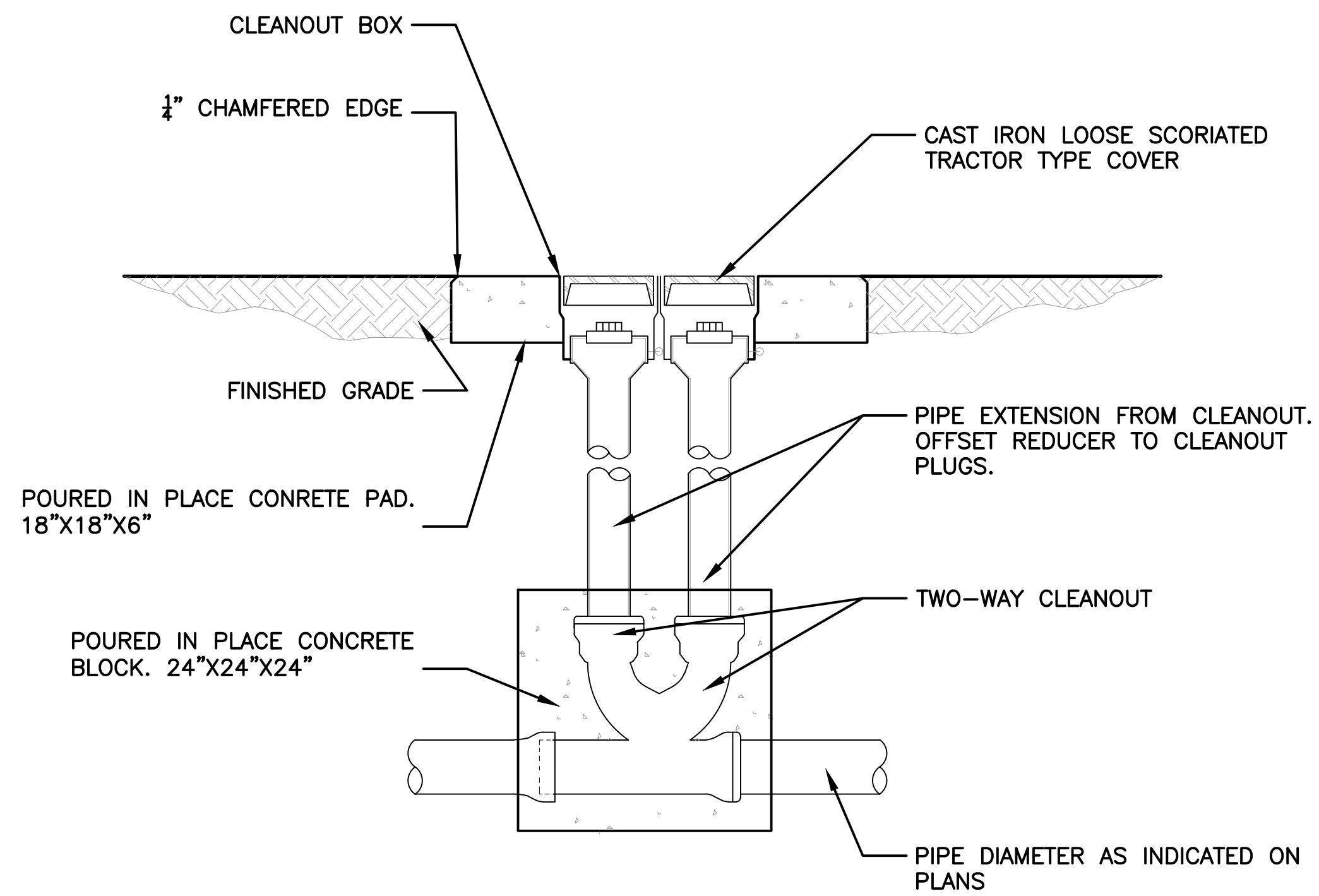

① TWO-WAY CLEANOUT DTL. (TYP.)
N.T.S

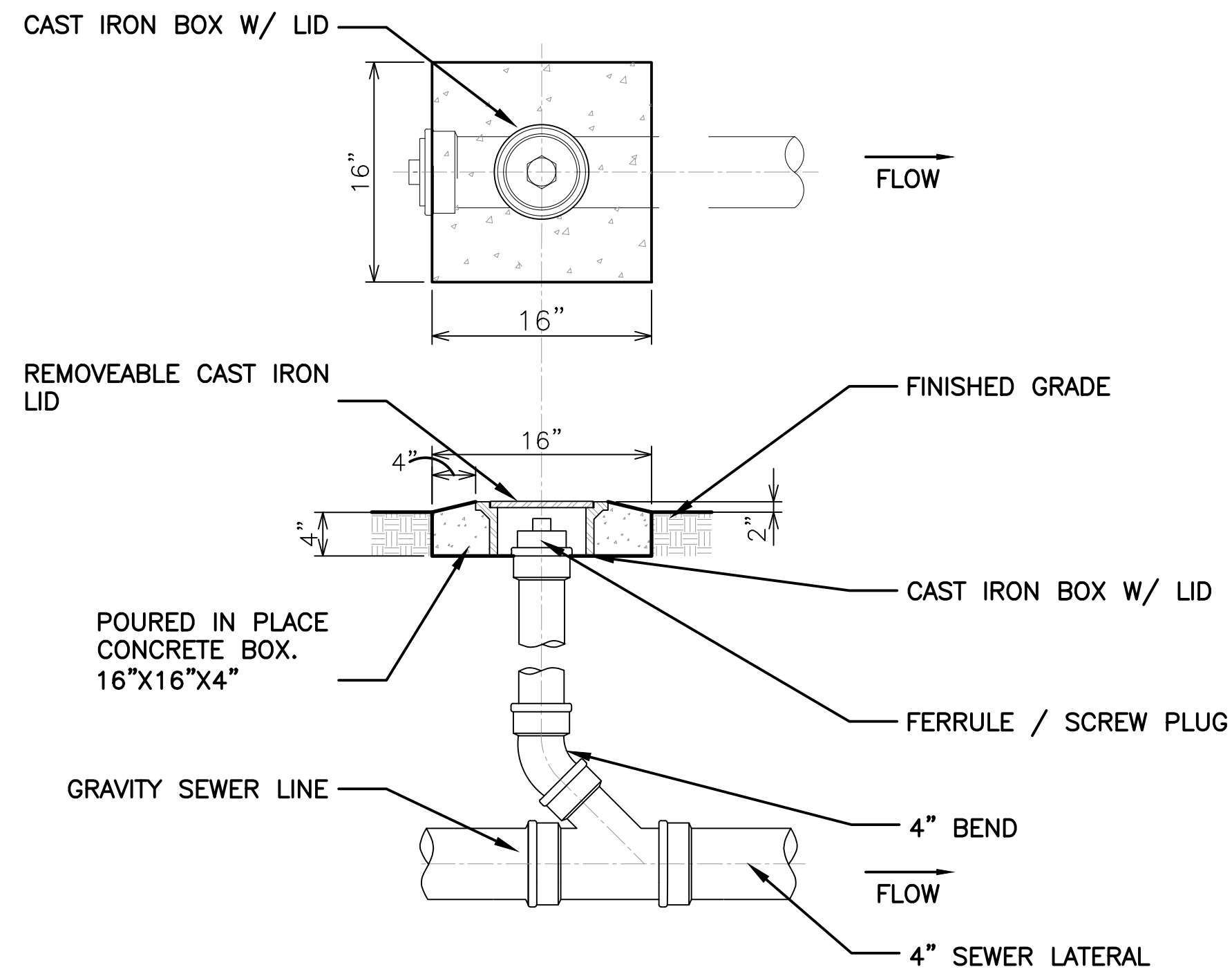

② YARD CLEANOUT DTL. (TYP.)
N.T.S

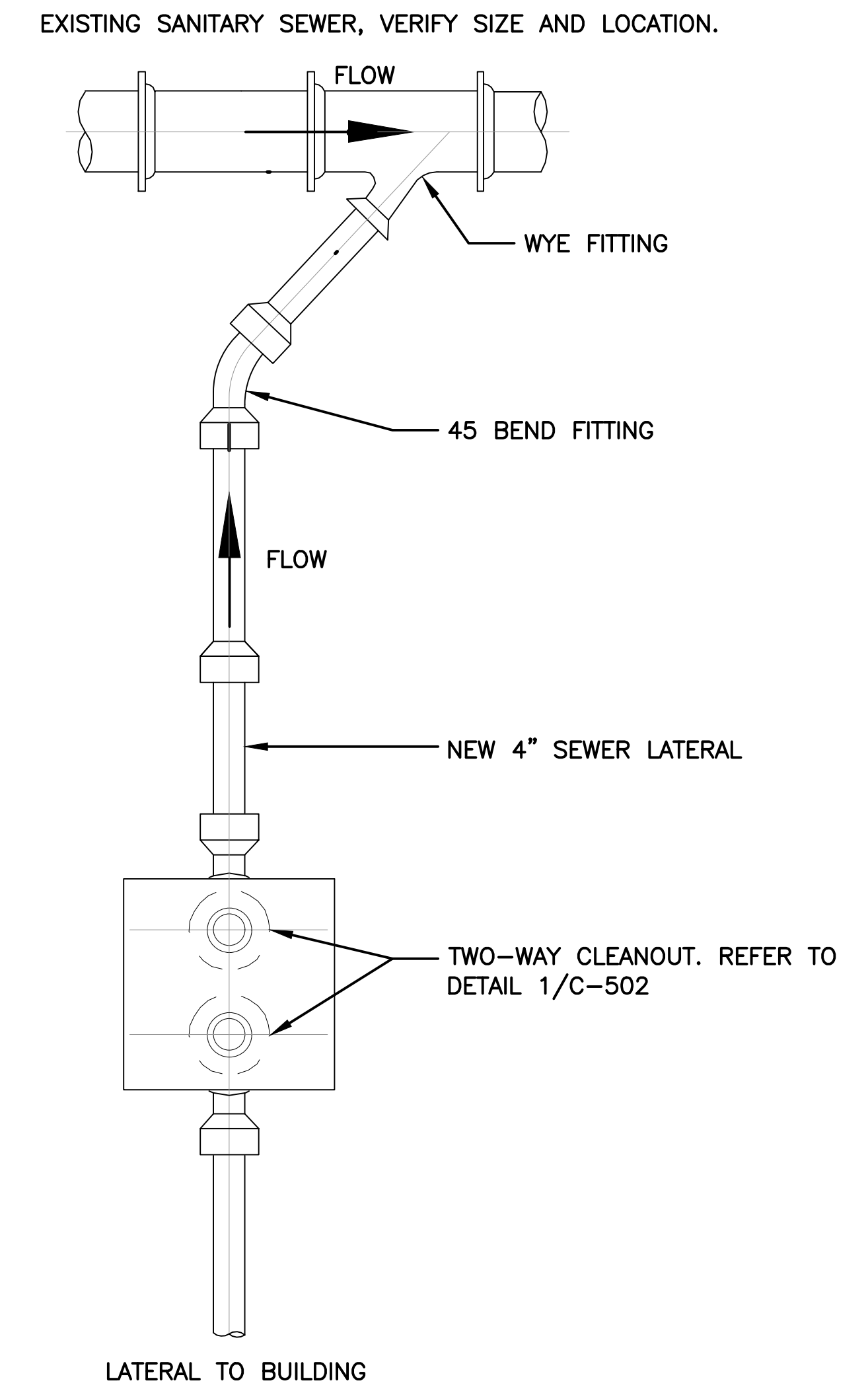

③ TYPICAL SEWER CONNECTION DETAIL
N.T.S

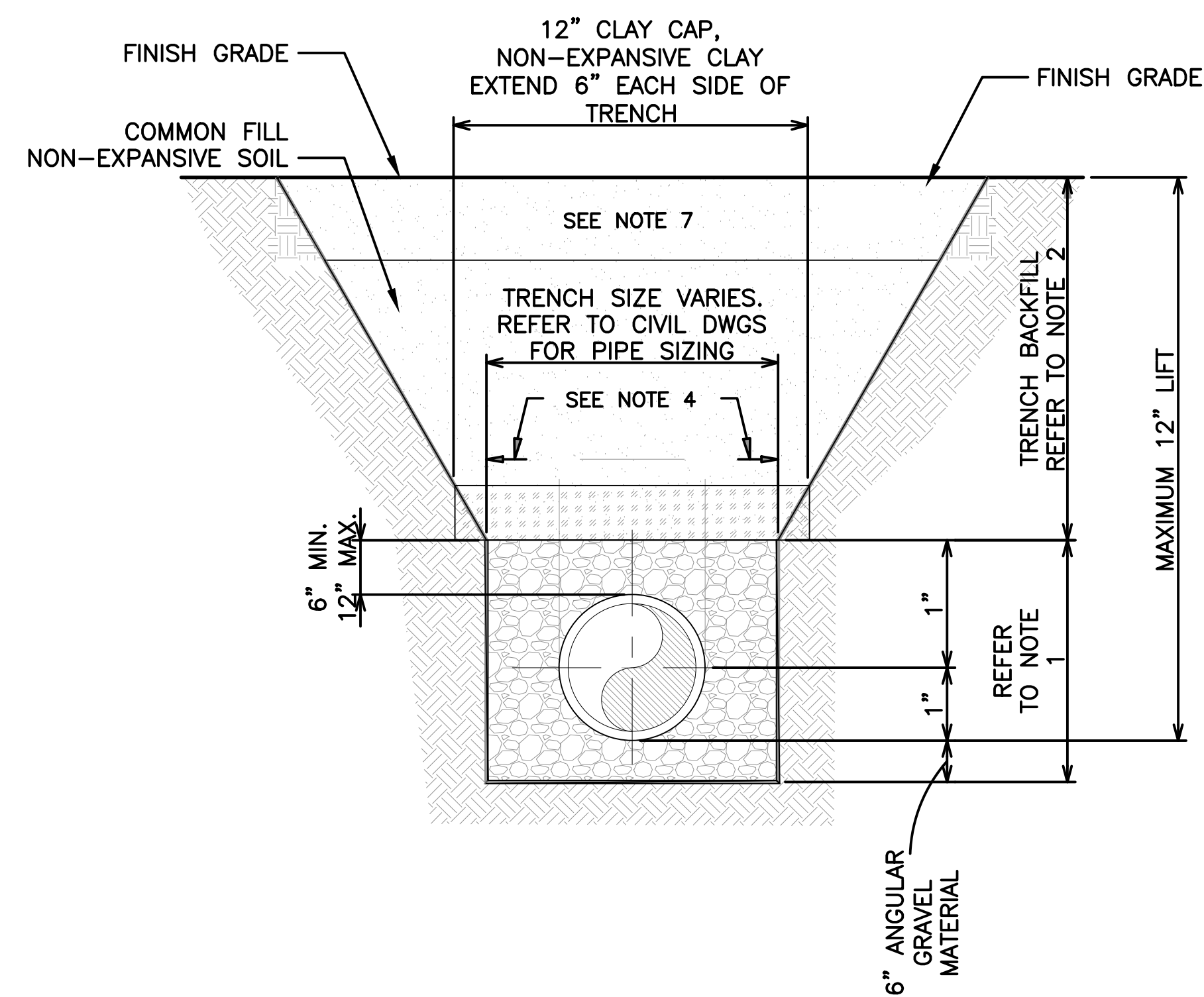

④ TRENCHING AND BEDDING DTL.
N.T.S

NOTES:

1. INITIAL BACKFILL AND HAUNCHING: ANGULAR GRAVEL MATERIAL COMPACTED TO 95% OF THE MAXIMUM DENSITY.
2. TRENCH BACKFILL—COMMON FILL COMPACTED TO 95% OF THE MAXIMUM DENSITY. SITE EXCAVATED MATERIALS ARE NOT SUITABLE BACKFILL FOR COMMON FILL. COMMON FILL SHALL BE NON-EXPANSIVE SOIL.
3. 12" MAX. (6" MIN.) FOR PIPE DIAMETER LESS THAN 24" AND 24" MAX (12" MIN) FOR PIPE DIAMETER 24" AND LARGER.
4. WATER SHALL NOT BE PERMITTED IN THE TRENCH DURING CONSTRUCTION.
5. ALL PIPE TO BE INSTALLED WITH BELL FACING UPSTREAM TO THE DIRECTION OF THE FLOW.
6. FINAL RESTORATION IN IMPROVED AREAS SHALL BE IN COMPLIANCE WITH STATEMENT OF WORK AND TO THE SATISFACTION OF THE CONTRACTING OFFICER.
7. IN GREEN AREAS THE TOP 1/4 OF THE EXCAVATION THE USE OF EXCAVATED MATERIALS FOR FINAL BACKFILL OF TRENCHES. EXISTING MATERIAL MUST BE FREE OF LARGE STONES, CLODS AND ORGANIC MATTER. COMPACTED TO 95% OF STANDARD PROCTOR IN PAVED AREAS.

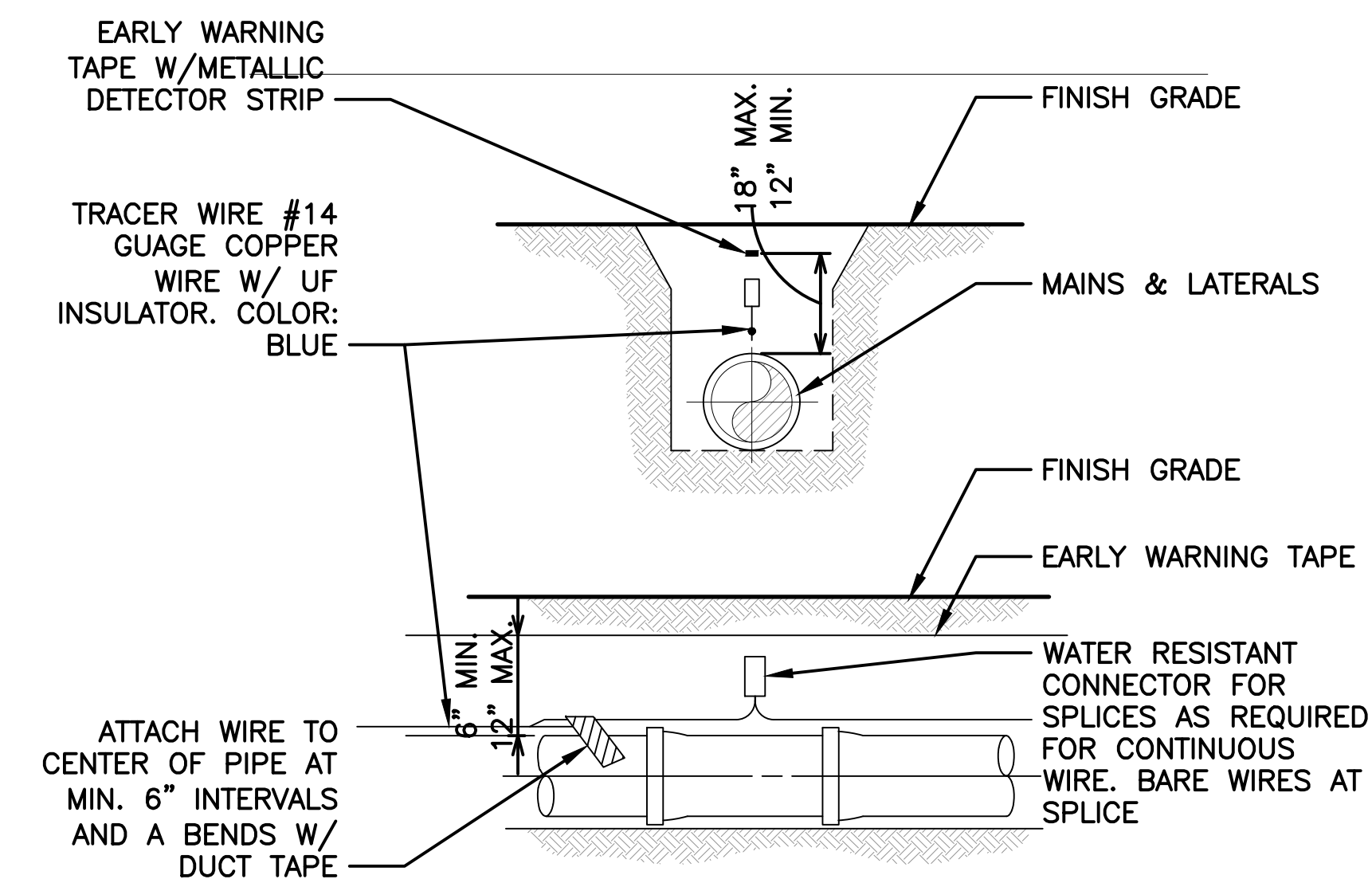

⑤ PIPE LOCATING DTL.
N.T.S

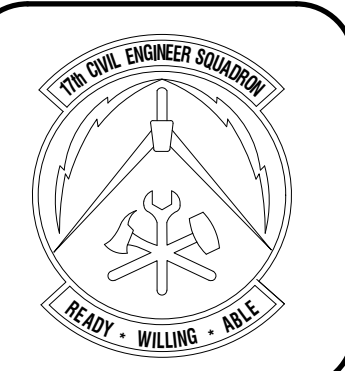

DESIGNED BY	JH/ML/LA
DRAWN BY	JH/ML/LA
REVIEWED BY	RT/JH
SUBMITTED BY	PC/ES

PROJECT TITLE	FIRE STATION ADD/ALTER, B3321
PROJECT NO.	1039839
TRAINING WING	17th TRAINING WING
LOCATION	GOODFELLOW AIR FORCE BASE, TEXAS

PROJECT TITLE	FIRE STATION ADD/ALTER, B3321
PROJECT NO.	1039839
TRAINING WING	17th TRAINING WING
LOCATION	GOODFELLOW AIR FORCE BASE, TEXAS

PROJECT NUMBER	1039839
SHEET TITLE	SITE DETAILS
DATE	SEP 2023

SEQ.	SHEET	OF
16	C-502	50

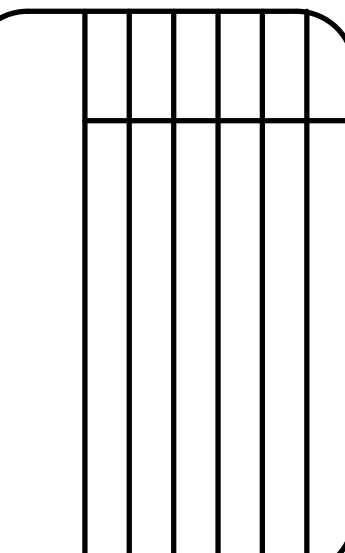
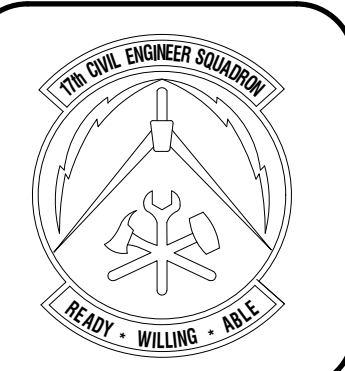

Designed by
JH/ML/LA

Drawn by
JH/ML/LA

Reviewed by
RT/JAH

Submitted by
PC/ES

PROJECT TITLE

FIRE STATION ADD/ALTER, B3321
PROJECT NO. 1039839
17th TRAINING WING
GOODFELLOW AIR FORCE BASE, TEXAS

Project Number:
1039839

SHEET TITLE
DEMO PLAN

Date:
SEP 2023

SEQ.	SHEET	OF
17	AD-101	50

KEYNOTES AS INDICATED BY (X)

1. CONTRACTOR SHALL DEMO EXISTING HALF WALL INCLUDING FRAMING, GYP. BD., TRIM, AND MOLDING.
2. CONTRACTOR SHALL DEMO EXISTING CARPET FLOORING AND RUBBER BASE. CONTRACTOR SHALL SCRAPE AND PREPARE SURFACE FOR NEW FLOORING AND FLOOR BASE.
3. CONTRACTOR SHALL DEMO EXISTING CEILING SYSTEM AND LIGHT FIXTURES.
4. CONTRACTOR SHALL DEMO RESTROOM DOOR AND FRAME. CONTRACTOR SHALL DEMO EXISTING FLOOR BASE TO NEAREST JOINT.
5. CONTRACTOR SHALL CUT OPENING TO RESTROOM. PROVIDE NEW FRAMING AS NEEDED FOR NEW DOORWAY.
6. CONTRACTOR SHALL REMOVE EXISTING WALL BASE MATERIAL. CONTRACTOR SHALL PROTECT EXISTING FIXTURES AND PARTITIONS.
7. CONTRACTOR SHALL DEMO EXISTING METAL GUTTER AND DOWNSPOUT.
8. CONTRACTOR SHALL DEMO EXISTING STANDING SEAM METAL PANELS FOR NEW BREEZEWAY AND ADDITION. REMOVE ENTIRE PANEL TO RIDGE.
9. CONTRACTOR SHALL DEMO EXISTING WALL AND INSULATION TO STUD. EXISTING ELECTRICAL CONDUIT, WIRING, BOXES, AND CIRCUITS MAY BE REUSED WHERE APPLICABLE. HOWEVER, CONTRACTOR SHALL PROVIDE ALL NEW RECEPTACLES, COVERS, AND SWITCHES THROUGHOUT. REFER TO ELECTRICAL.

GENERAL NOTES

1. CONTRACTOR SHALL BE RESPONSIBLE FOR VERIFYING EXISTING DIMENSIONS, EQUIPMENT, AND CONDITIONS PRIOR TO START OF WORK.
2. CONTRACTOR SHALL ENSURE WORK AREAS SHALL BE KEPT CLEAN, SAFE, AND IN A WORKMANLIKE CONDITION. DEBRIS SHALL BE CLEANED ON A DAILY BASIS AND SITE SHALL BE MAINTAINED IN ACCORDANCE WITH THE SPECIFICATIONS.
3. THE CONTRACTOR SHALL TAKE APPROPRIATE STEPS TO PROTECT BUILDING ELEMENTS OUTSIDE THE SCOPE OF WORK AND LABELED AS "EXISTING TO REMAIN". DAMAGE TO THESE ITEMS REQUIRING REPAIR OR REPLACEMENT SHALL BE PERFORMED BY THE CONTRACTOR AT NO ADDITIONAL COST TO THE GOVERNMENT.
4. CONTRACTOR SHALL COORDINATE WITH ALL OTHER TRADES.
5. FOR UNDER-SLAB DEMO, CONTRACTOR SHALL DEMO THE MINIMUM NECESSARY CONCRETE TO PROVIDE FOR NEW PLUMBING INSTALLATION.

LEGEND

- EXISTING TO REMAIN
- DEMO

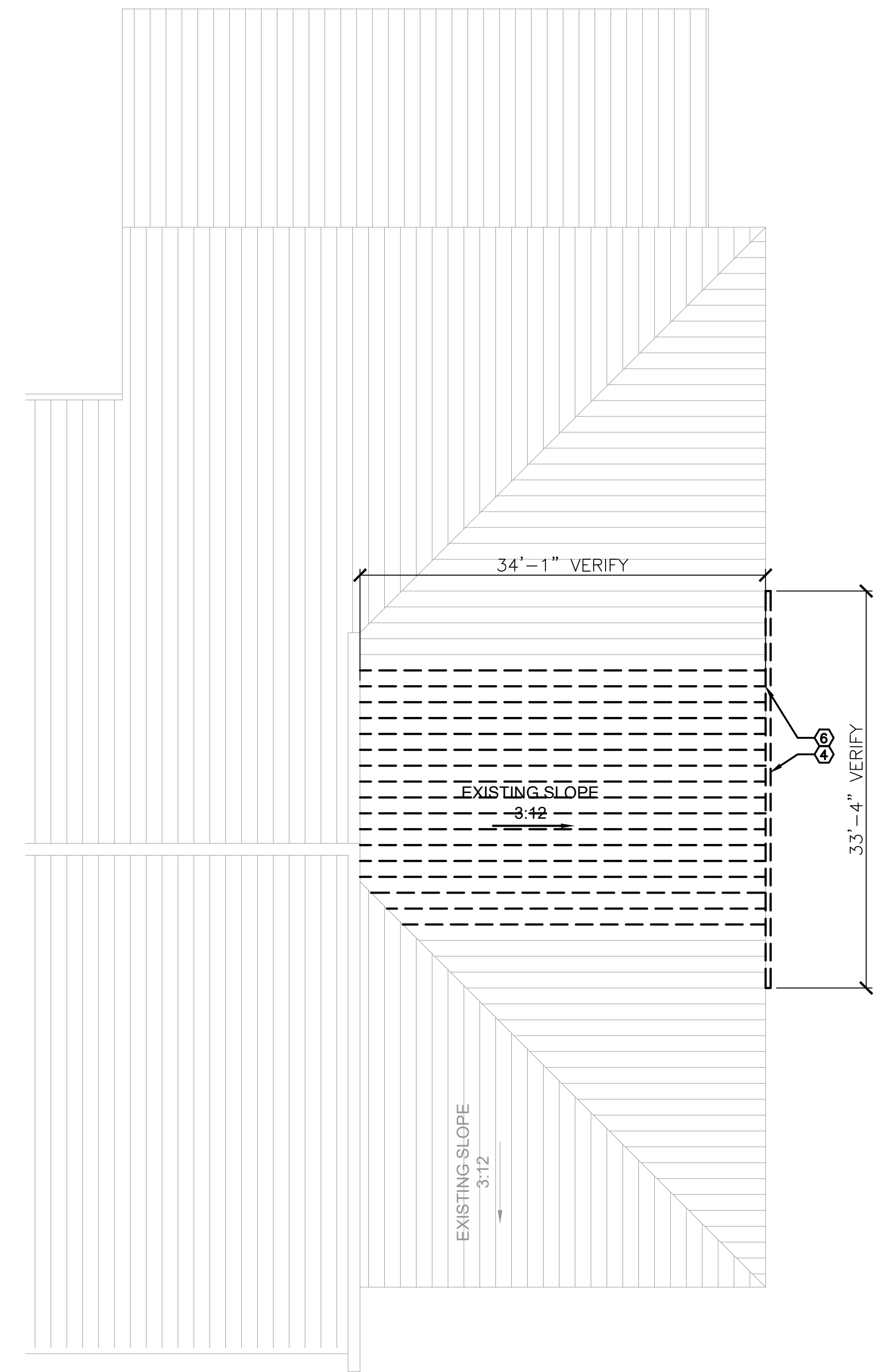

1 DEMO PLAN-BASE BID
1/8" = 1' - 0"
PLAN NORTH ↑ TRUE NORTH ↑

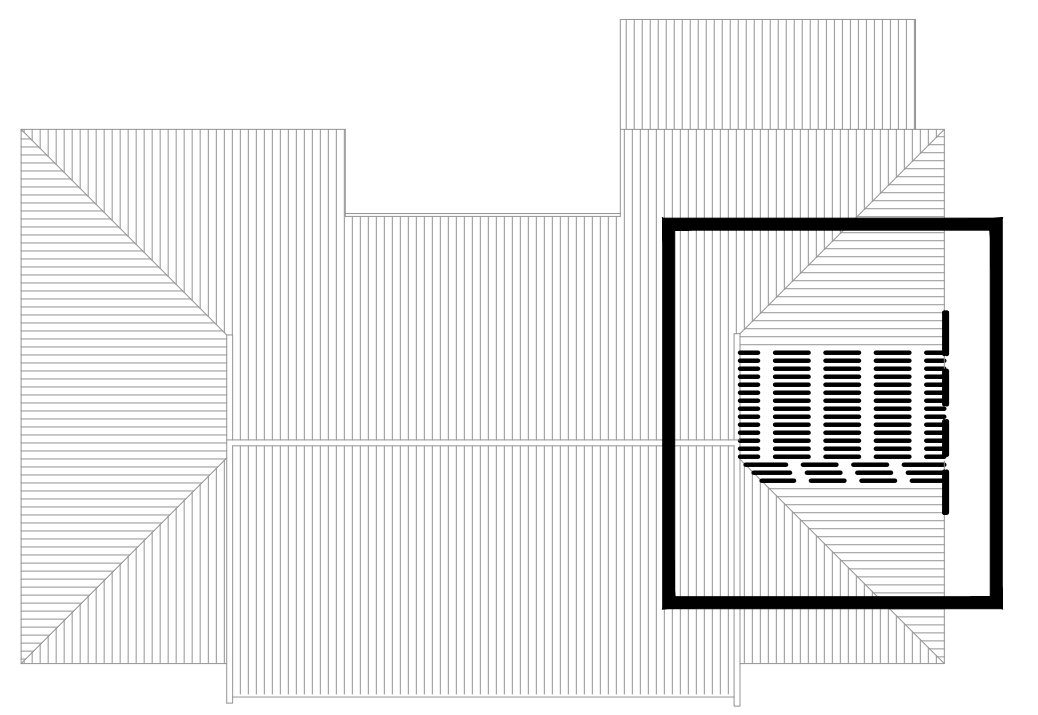

KEY PLAN

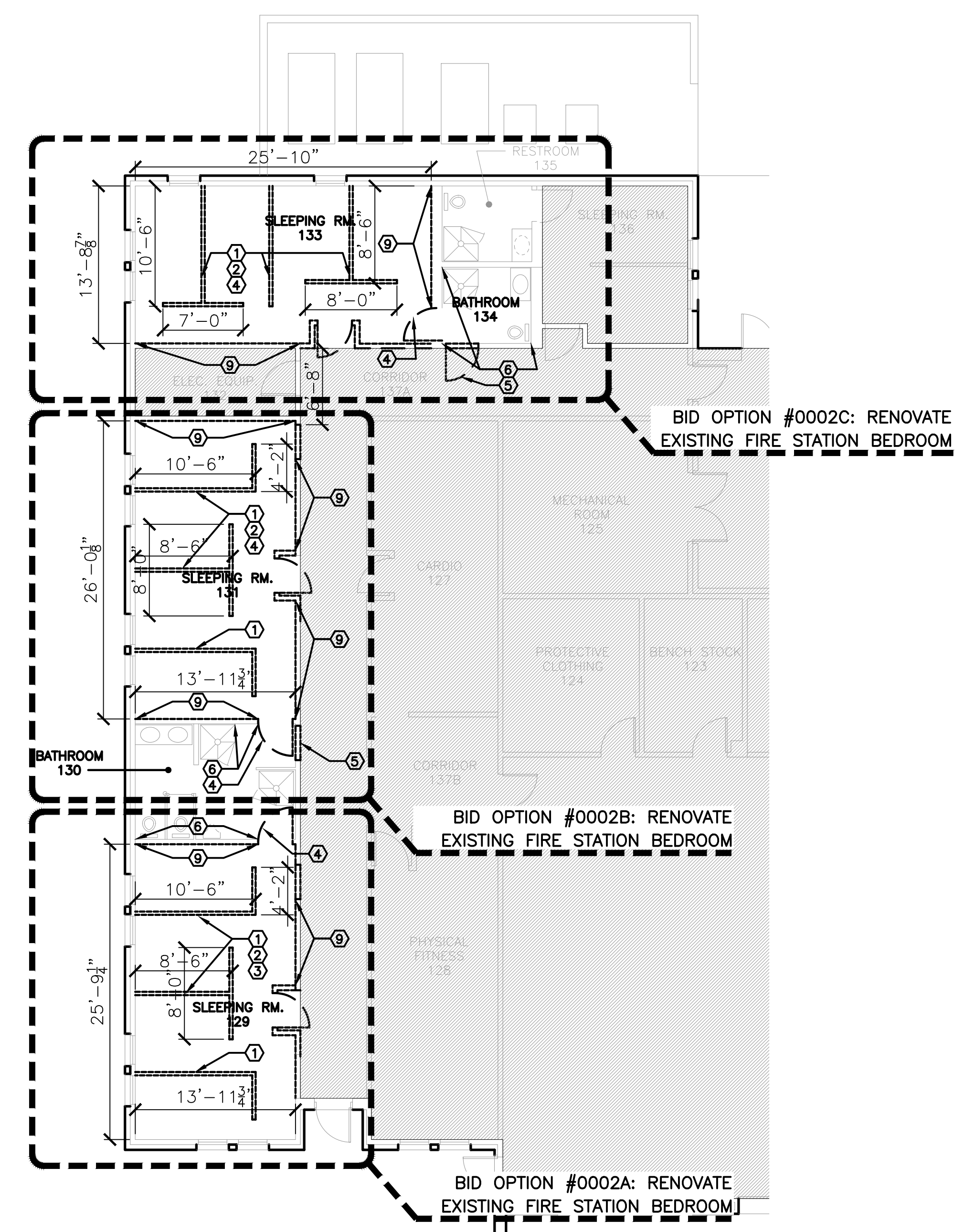

2 DEMO PLAN-BID OPTION
1/8" = 1' - 0"
PLAN NORTH ↑ TRUE NORTH ↑

PROJECT TITLE

Project Number:
1039839

SHEET TITLE
DEMO PLAN

Date:
SEP 2023

SEQ.	SHEET	OF
17	AD-101	50

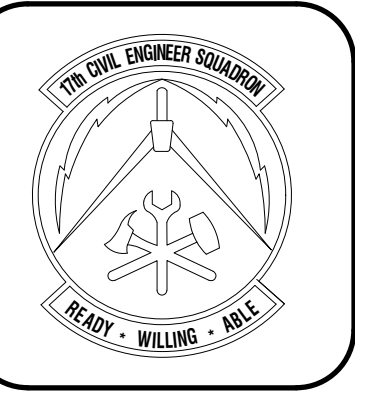

Designed by JH/MLLA	Checked by JH/MLLA	Reviewed by RT/AF	Submitted by PC/ES
------------------------	-----------------------	----------------------	-----------------------

PROJECT TITLE	FIRE STATION ADD/ALTER, B3321 PROJECT NO. 1039839 17th TRAINING WING GOODFELLOW AIR FORCE BASE, TEXAS
---------------	--

PROJECT NUMBER	1039839	
SHEET TITLE	FLOORPLAN NEW - OVERALL FLOORPLAN	
DATE	SEP 2023	
SEQ.	SHEET	OF
18	A-101	50

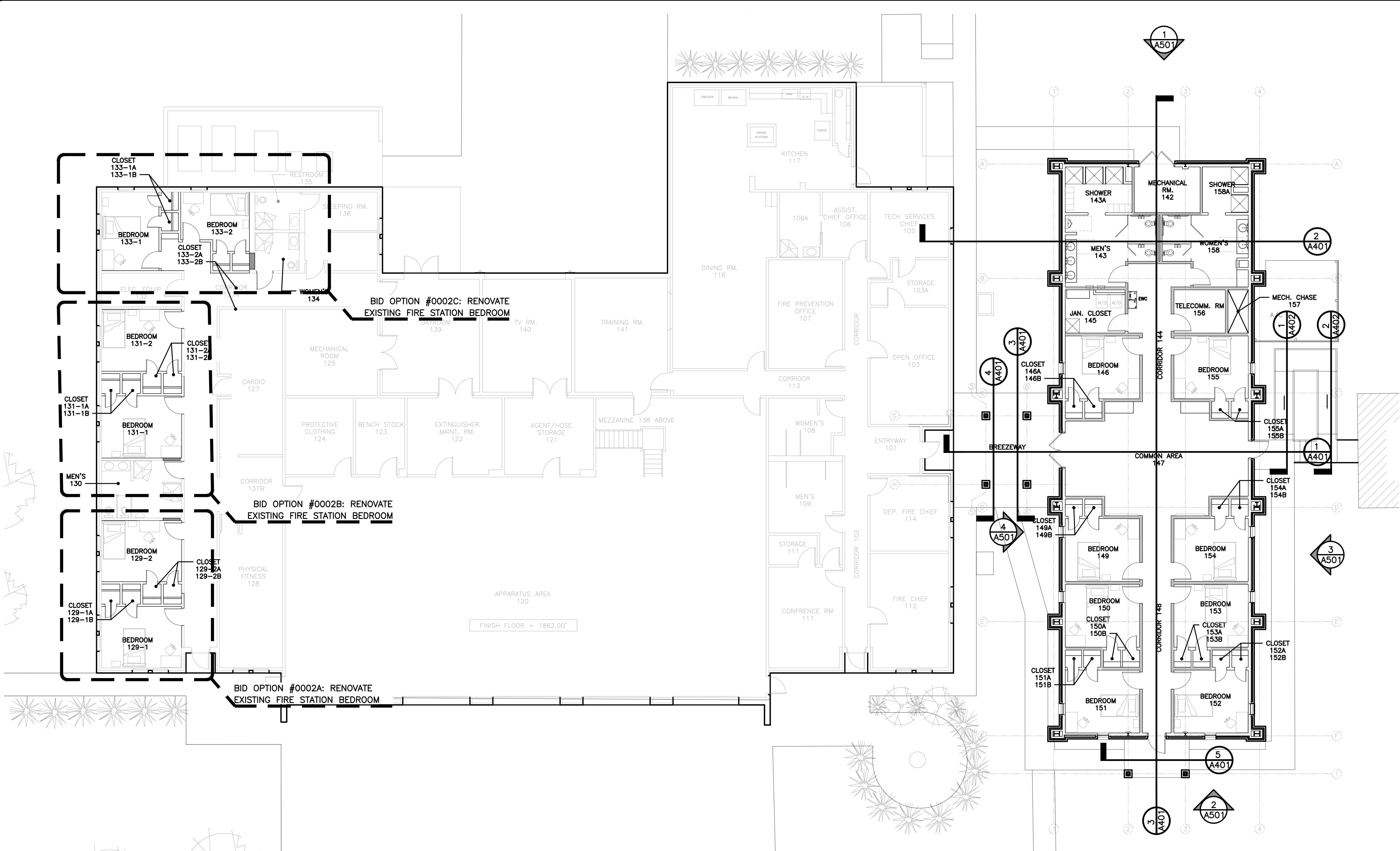

1 OVERALL FLOORPLAN NEW
 1/8" = 1' - 0"
 PLAN NORTH ↑
 TRUE NORTH ↑

- GENERAL NOTES**
- CONTRACTOR SHALL BE RESPONSIBLE FOR VERIFYING EXISTING DIMENSIONS, EQUIPMENT, AND CONDITIONS PRIOR TO START OF WORK.
 - CONTRACTOR SHALL ENSURE WORK AREAS SHALL BE KEPT CLEAN, SAFE, AND IN A WORKMANLIKE CONDITION. DEBRIS SHALL BE CLEANED ON A DAILY BASIS AND SITE SHALL BE MAINTAINED IN ACCORDANCE WITH THE SPECIFICATIONS.
 - THE CONTRACTOR SHALL TAKE APPROPRIATE STEPS TO PROTECT BUILDING ELEMENTS OUTSIDE THE SCOPE OF WORK AND LABELED AS "EXISTING TO REMAIN". DAMAGE TO THESE ITEMS REQUIRING REPAIR OR REPLACEMENT SHALL BE PERFORMED BY THE CONTRACTOR AT NO ADDITIONAL COST TO THE GOVERNMENT.
 - CONTRACTOR SHALL COORDINATE WITH ALL OTHER TRADES.

LEGEND

SECTION TAG
RE: A/401

EXTERIOR TAG
RE: A/501

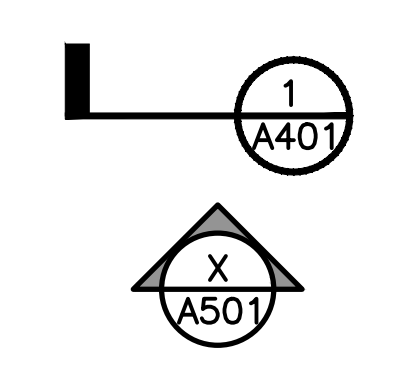

PROJECT TITLE	FIRE STATION ADD/ALTER, B3321 PROJECT NO. 1039839 17th TRAINING WING GOODFELLOW AIR FORCE BASE, TEXAS
---------------	--

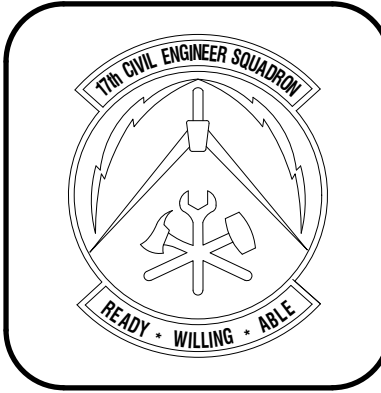

GENERAL NOTES

1. FURNITURE IS SHOWN FOR CLARITY. FURNITURE TO BE PROVIDED BY OTHERS.
2. CONTRACTOR SHALL BE RESPONSIBLE FOR VERIFYING EXISTING DIMENSIONS, EQUIPMENT, AND CONDITIONS PRIOR TO START OF WORK.
3. CONTRACTOR SHALL ENSURE WORK AREAS SHALL BE KEPT CLEAN, SAFE, AND IN A WORKMANLIKE CONDITION. DEBRIS SHALL BE CLEANED ON A DAILY BASIS AND SITE SHALL BE MAINTAINED IN ACCORDANCE WITH THE SPECIFICATIONS.
4. THE CONTRACTOR SHALL TAKE APPROPRIATE STEPS TO PROTECT BUILDING ELEMENTS OUTSIDE THE SCOPE OF WORK AND LABELED AS "EXISTING TO REMAIN". DAMAGE TO THESE ITEMS REQUIRING REPAIR OR REPLACEMENT SHALL BE PERFORMED BY THE CONTRACTOR AT NO ADDITIONAL COST TO THE GOVERNMENT.
5. CONTRACTOR SHALL COORDINATE WITH ALL OTHER TRADES.
6. IN ALL BID OPTIONS THE CONTRACTOR SHALL BE RESPONSIBLE FOR PATCHING, REPAIRING, TAPING, FLOATING, AND TEXTURING EXPOSED OR DAMAGED SURFACES FROM DEMO'D AREAS.

LEGEND

- INTERIOR ELEVATION TAG RE: A701
- DOOR TAG RE: A802
- WINDOW TAG RE: A-802
- PARTITION TYPE RE: A-601
- BATT INSULATION

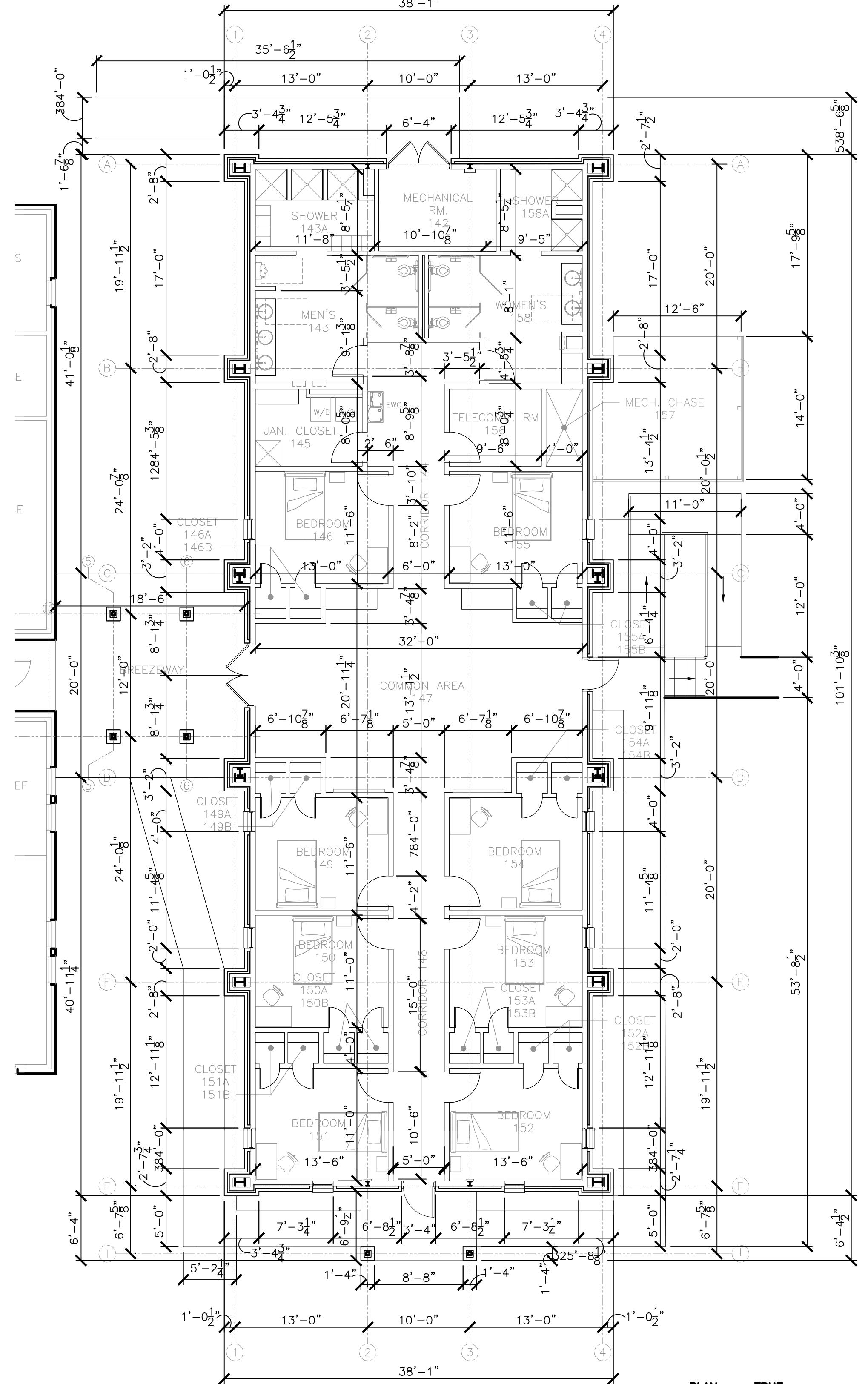
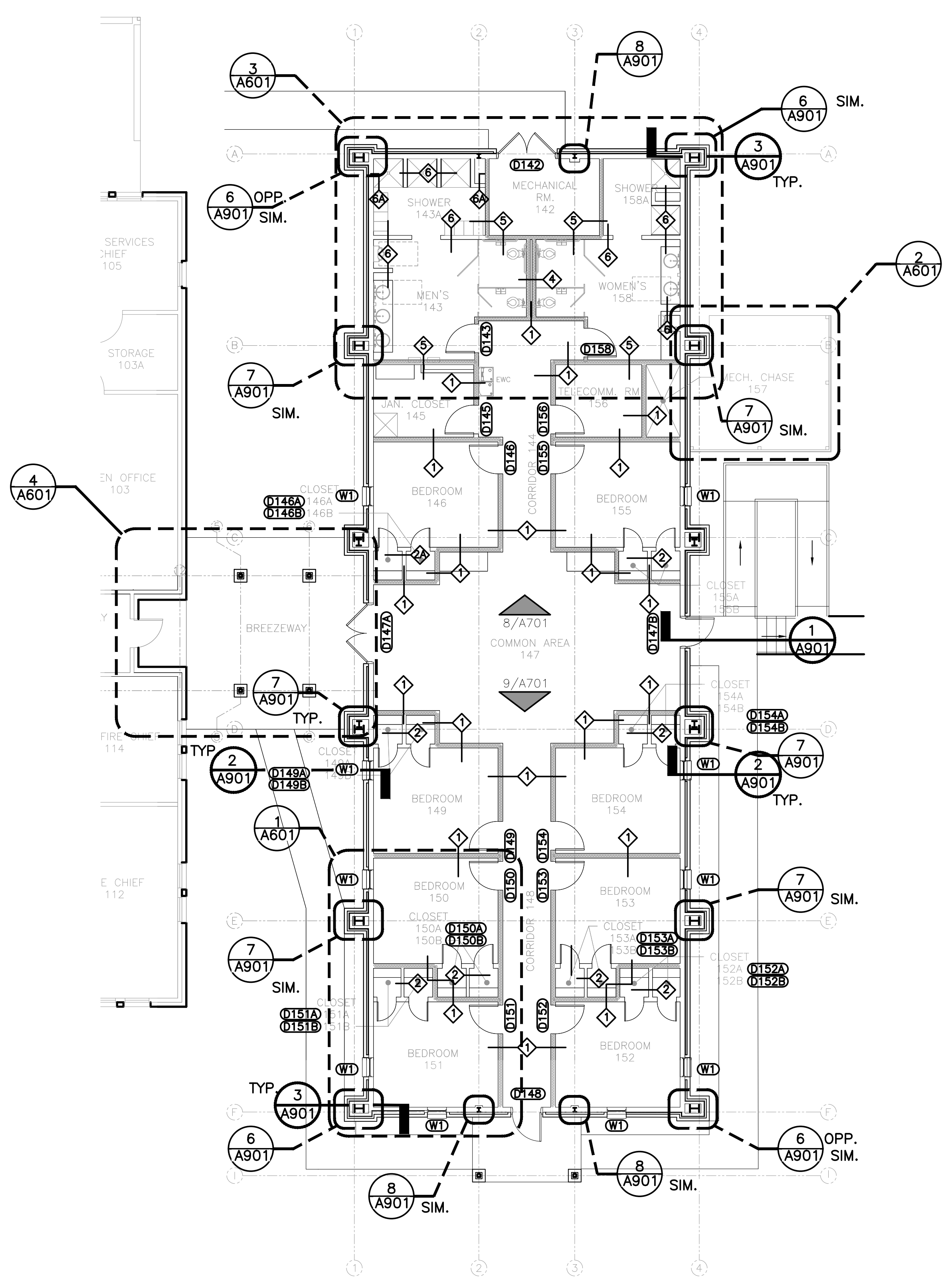

① NEW FLOORPLAN - ANNOTATED PLAN
 $\frac{1}{8}'' = 1' - 0''$
 PLAN NORTH ↑ TRUE NORTH ↑

② NEW FLOORPLAN - DIMENSION PLAN
 $\frac{1}{8}'' = 1' - 0''$
 PLAN NORTH ↑ TRUE NORTH ↑

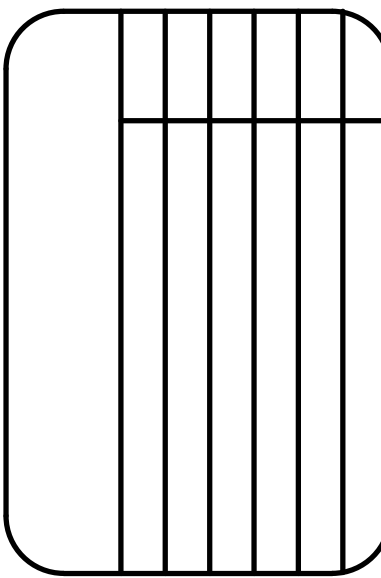

Designed by:
JHR/LA
 Drawn by:
JHR/LA
 Reviewed by:
RT/JH
 Submitted by:
PCES

PROJECT TITLE
FIRE STATION ADD/ALTER, B3321
PROJECT NO. 1039839
17th TRAINING WING
GOODFELLOW AIR FORCE BASE, TEXAS

Project Number:
1039839
 SHEET TITLE
FLOORPLAN NEW - NEW ADDITION
 Date:
SEP 2023

SEQ. SHEET OF
 19 **A-102** 50

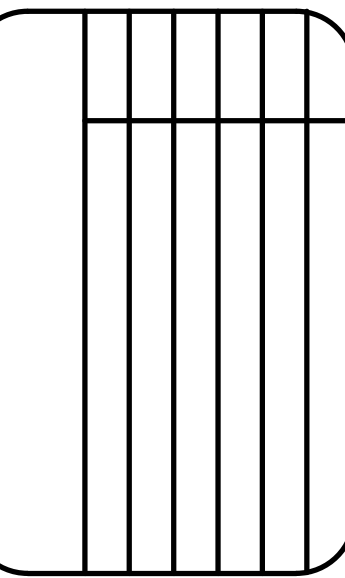
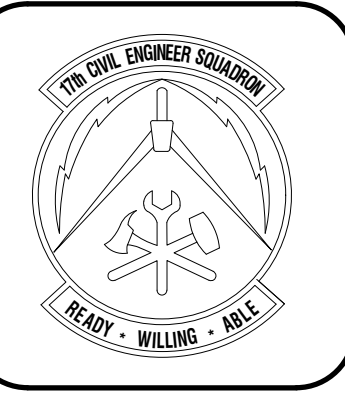

Designed by
JH/MLA

Drawn by
JH/MLA

Reviewed by
RT/JH

Submitted by
PC/ES

PROJECT TITLE

FIRE STATION ADD/ALTER, B3321
PROJECT NO. 1039839
17th TRAINING WING
GOODFELLOW AIR FORCE BASE, TEXAS

Project Number:
1039839

SHEET TITLE
FLOORPLAN NEW - BID
OPTIONS

Date:
SEP 2023

SEQ. SHEET OF
20 **A-103** 50

GENERAL NOTES

- FURNITURE IS SHOWN FOR CLARITY. FURNITURE TO BE PROVIDED BY OTHERS.
- CONTRACTOR SHALL BE RESPONSIBLE FOR VERIFYING EXISTING DIMENSIONS, EQUIPMENT, AND CONDITIONS PRIOR TO START OF WORK.
- CONTRACTOR SHALL ENSURE WORK AREAS SHALL BE KEPT CLEAN, SAFE, AND IN A WORKMANLIKE CONDITION. DEBRIS SHALL BE CLEANED ON A DAILY BASIS AND SITE SHALL BE MAINTAINED IN ACCORDANCE WITH THE SPECIFICATIONS.
- THE CONTRACTOR SHALL TAKE APPROPRIATE STEPS TO PROTECT BUILDING ELEMENTS OUTSIDE THE SCOPE OF WORK AND LABELED AS "EXISTING TO REMAIN". DAMAGE TO THESE ITEMS REQUIRING REPAIR OR REPLACEMENT SHALL BE PERFORMED BY THE CONTRACTOR AT NO ADDITIONAL COST TO THE GOVERNMENT.
- CONTRACTOR SHALL COORDINATE WITH ALL OTHER TRADES.
- WHERE BID OPTIONS REQUIRE THE DEMO OF RESTROOM DOORS. CONTRACTOR SHALL BE RESPONSIBLE FOR DEMOLISHING EXISTING DOORS AS INDICATED ON THE DEMO PLAN. CONTRACTOR SHALL PATCH AND REPAIR SURROUNDING SURFACES, TAPE, FLOAT, TEXTURE TO MATCH, PRIME AND PAINT TO EXISTING WALL. CONTRACTOR SHALL PAINT THE ENTIRE WALL AND PROVIDE NEW FLOOR BASE SIMILAR TO EXISTING. CONTRACTOR SHALL TAPE OFF AND PROTECT EXISTING PARTITIONS, FLOORING, AND FIXTURES FROM DAMAGE.
- IN ALL BID OPTION AREAS: THE CONTRACTOR SHALL BE RESPONSIBLE FOR PATCHING, REPAIRING, TAPING, FLOATING, AND TEXTURING EXPOSED OR DAMAGED SURFACES FROM DEMO'D AREAS.
- IN ALL BID OPTION AREAS: WHERE EXISTING RESTROOM, CORRIDOR, OR ELECTRICAL CLOSET WALLS ARE TO REMAIN. CONTRACTOR SHALL PROVIDE NEW BATT INSULATION AND (2) LAYERS OF FC GYP. BD. ON THE BEDROOM SIDE. PROVIDE INSULATION TO TOP OF PARTITION.
- CONTRACTOR SHALL BE RESPONSIBLE FOR PROVIDING TEMPORARY WALL CONSTRUCTION AND DUST/SOUND PROTECTION FOR AREAS UNDER CONSTRUCTION IN ACCORDANCE WITH THE SPECIFICATIONS. CONTRACTOR ENTRANCE DURING CONSTRUCTION SHALL BE ADJACENT TO ROOM 129-1 UNLESS NOTED OTHERWISE.

LEGEND

- EXISTING TO REMAIN
- DOOR INFILL
- ELEVATION TAG
- BATT INSULATION
- PARTITION TYPE RE: A801/A802
- DOOR TAG RE: A801/A802

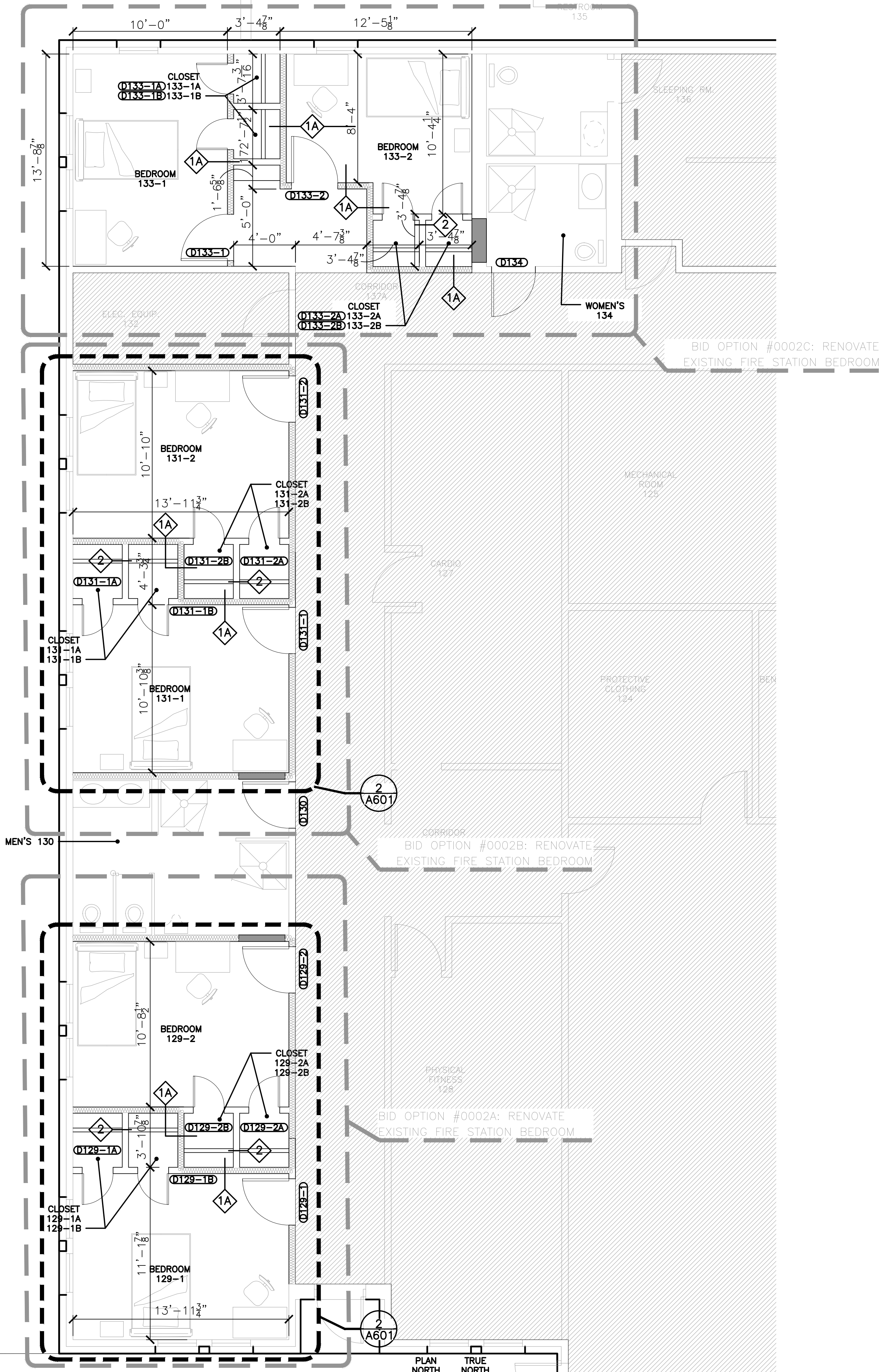

1 FLOORPLAN NEW - BID OPTIONS
1/4" = 1' - 0"

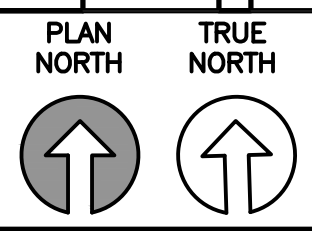

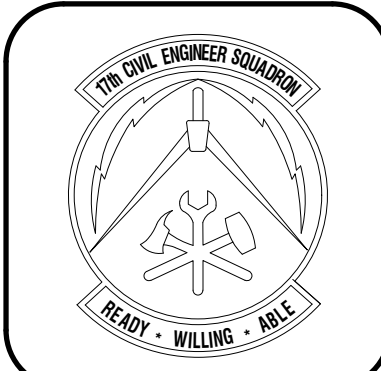

KEYNOTES AS INDICATED BY (X)

1. NEW PUBLIC ANNOUNCING (PA) SOFT START AUDIO OUTPUT SPEAKERS. TYP. ALL SLEEPING ROOMS.
2. NEW FIRE DEVICES AS REQ'D BY NEW QPPE DESIGN. TYP. ALL SLEEPING ROOMS. REFER TO FIRE ALARM.
3. MECHANICAL CHASE, NO CEILING REQ'D.
4. FURR DOWN BETWEEN NEW AND EXISTING CEILING GRIDS.

GENERAL NOTES

1. CONTRACTOR SHALL BE RESPONSIBLE FOR VERIFYING EXISTING DIMENSIONS, EQUIPMENT, AND CONDITIONS PRIOR TO START OF WORK.
2. CONTRACTOR SHALL ENSURE WORK AREAS SHALL BE KEPT CLEAN, SAFE, AND IN A WORKMANLIKE CONDITION. DEBRIS SHALL BE CLEANED ON A DAILY BASIS AND SITE SHALL BE MAINTAINED IN ACCORDANCE WITH THE SPECIFICATIONS.
3. THE CONTRACTOR SHALL TAKE APPROPRIATE STEPS TO PROTECT BUILDING ELEMENTS OUTSIDE THE SCOPE OF WORK AND LABELED AS "EXISTING TO REMAIN". DAMAGE TO THESE ITEMS REQUIRING REPAIR OR REPLACEMENT SHALL BE PERFORMED BY THE CONTRACTOR AT NO ADDITIONAL COST TO THE GOVERNMENT.
4. CONTRACTOR SHALL COORDINATE WITH ALL OTHER TRADES.
5. CONTRACTOR SHALL CENTER FIXTURES, SPRINKLER HEADS, DEVICES, AND ACCESSORIES BETWEEN CEILING TILES AS MUCH AS POSSIBLE.
6. IN BID OPTION AREAS, CONTRACTOR SHALL VERIFY CEILING HEIGHTS PRIOR TO DEMOLITION, AND PROVIDE NEW CEILINGS WITH SIMILAR HEIGHTS.

LEGEND

- EXISTING TO REMAIN
- CEILING HEIGHT
- 2'-0" X 2'-0" X 7/8" SUSP. GRID CLG SYSTEM. RE: 2/A201
- SUSP. 3/8" FC GYP BD CLG SYSTEM
- 2'4" LED RECESSED TROFFER LIGHT FIXTURE
- 6" LED ROUND RECESSED LIGHT FIXTURE
- SURFACE MOUNTED LED WALL PACK
- SURFACE MOUNTED LED UP/DN WALL SCONCE
- EXIT LIGHTING

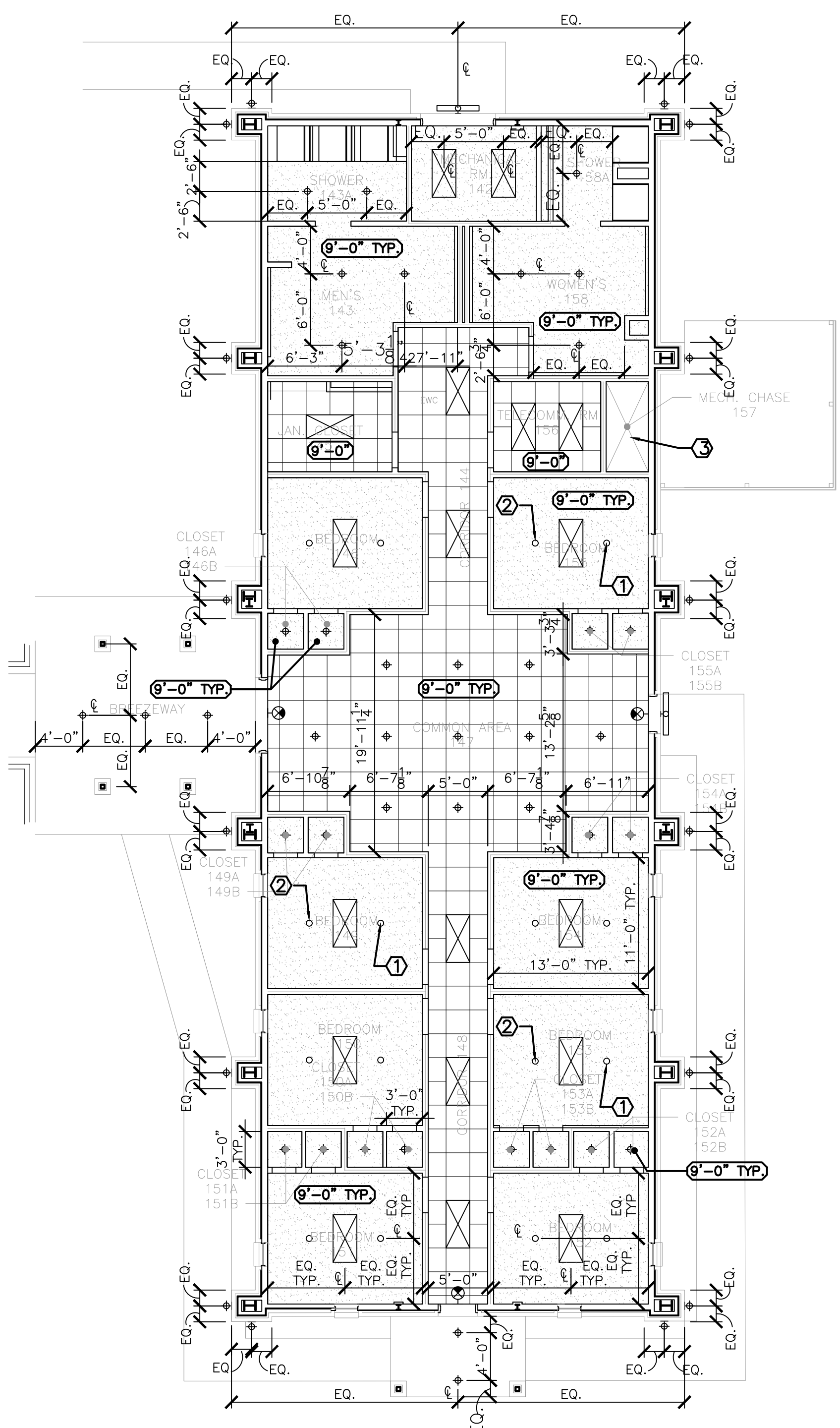

① REFLECTED CEILING PLAN - NEW ADDITION
1/8" = 1' - 0"

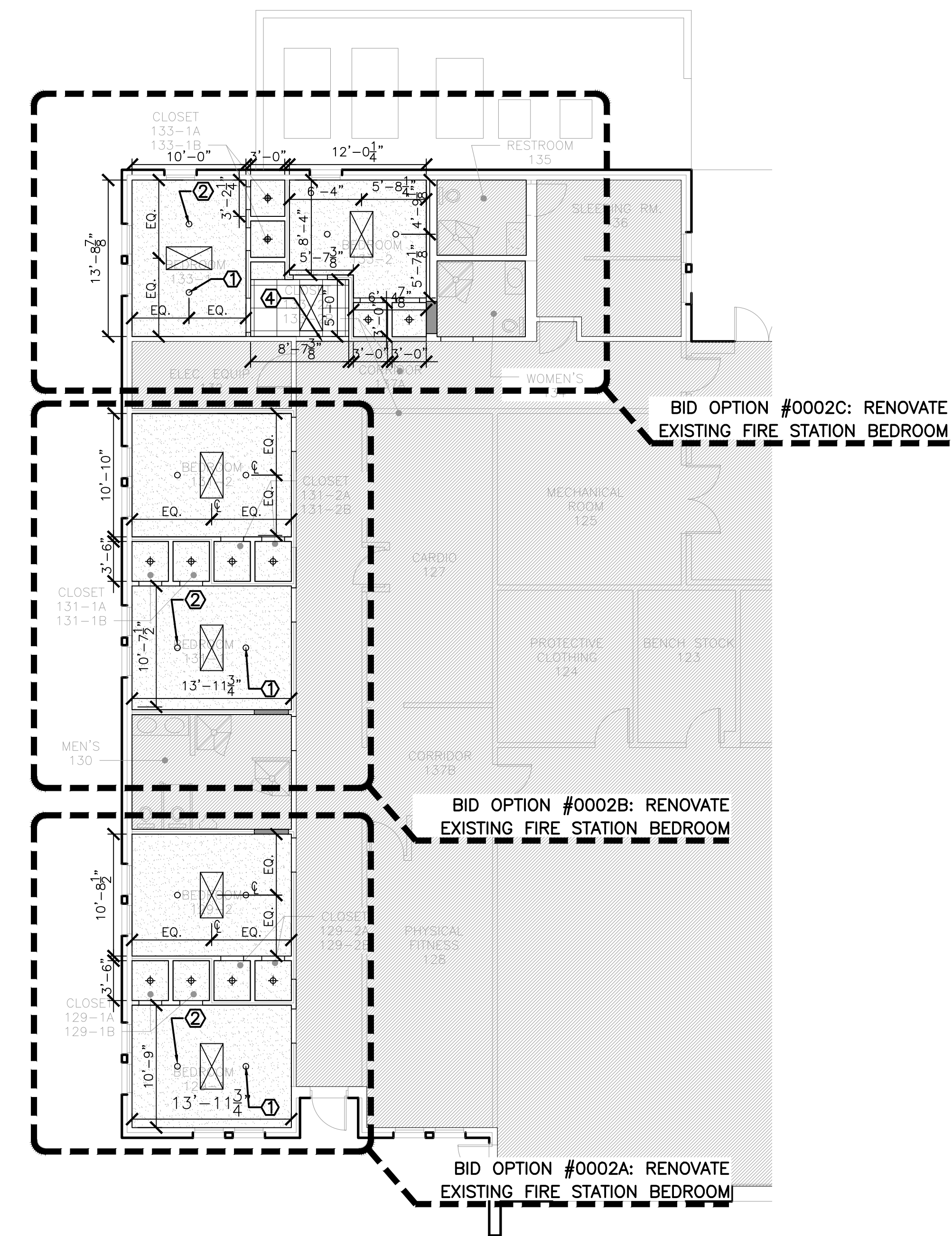
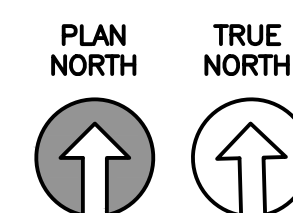

② REFLECTED CEILING PLAN - BID OPTIONS
1/8" = 1' - 0"

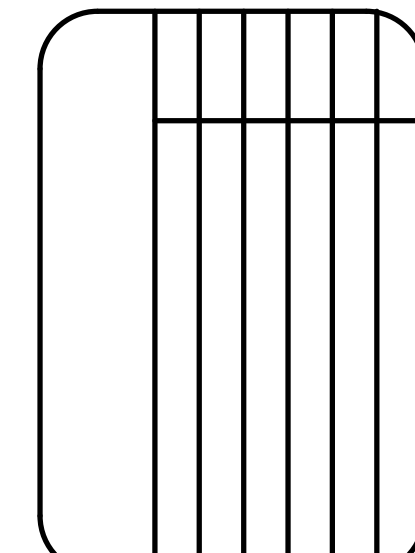
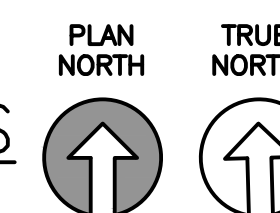

Designed by JH/MLA	Drawn by JH/MLA	Reviewed by RT/JH	Submitted by PC/S
-----------------------	--------------------	----------------------	----------------------

FIRE STATION ADD/ALTER, B3321
PROJECT NO. 1039839
17th TRAINING WING
GOODFELLOW AIR FORCE BASE, TEXAS

Project Number:	1039839
SHEET TITLE	REFLECTED CEILING PLAN
Date:	SEP 2023

SEQ.	SHEET	OF
21	A-201	50

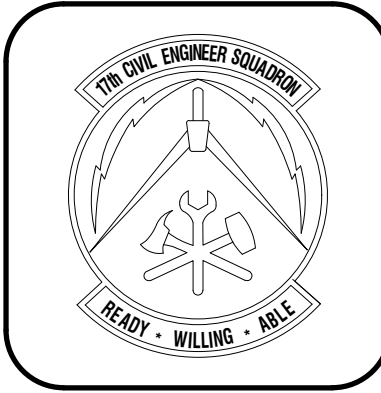

--	--	--	--	--	--

Designed by J.H.R.M.L.A.	Drawn by J.H.R.M.L.A.	Reviewed by RTI/AH	Submitted by PCBS
-----------------------------	--------------------------	-----------------------	----------------------

PROJECT TITLE
**FIRE STATION ADD/ALTER, B3321
 PROJECT NO. 1039839
 17th TRAINING WING
 GOODFELLOW AIR FORCE BASE, TEXAS**

Project Number: 1039839
SHEET TITLE ROOF PLAN
Date: SEP 2023

SEQ.	SHEET	OF
22	A-301	50

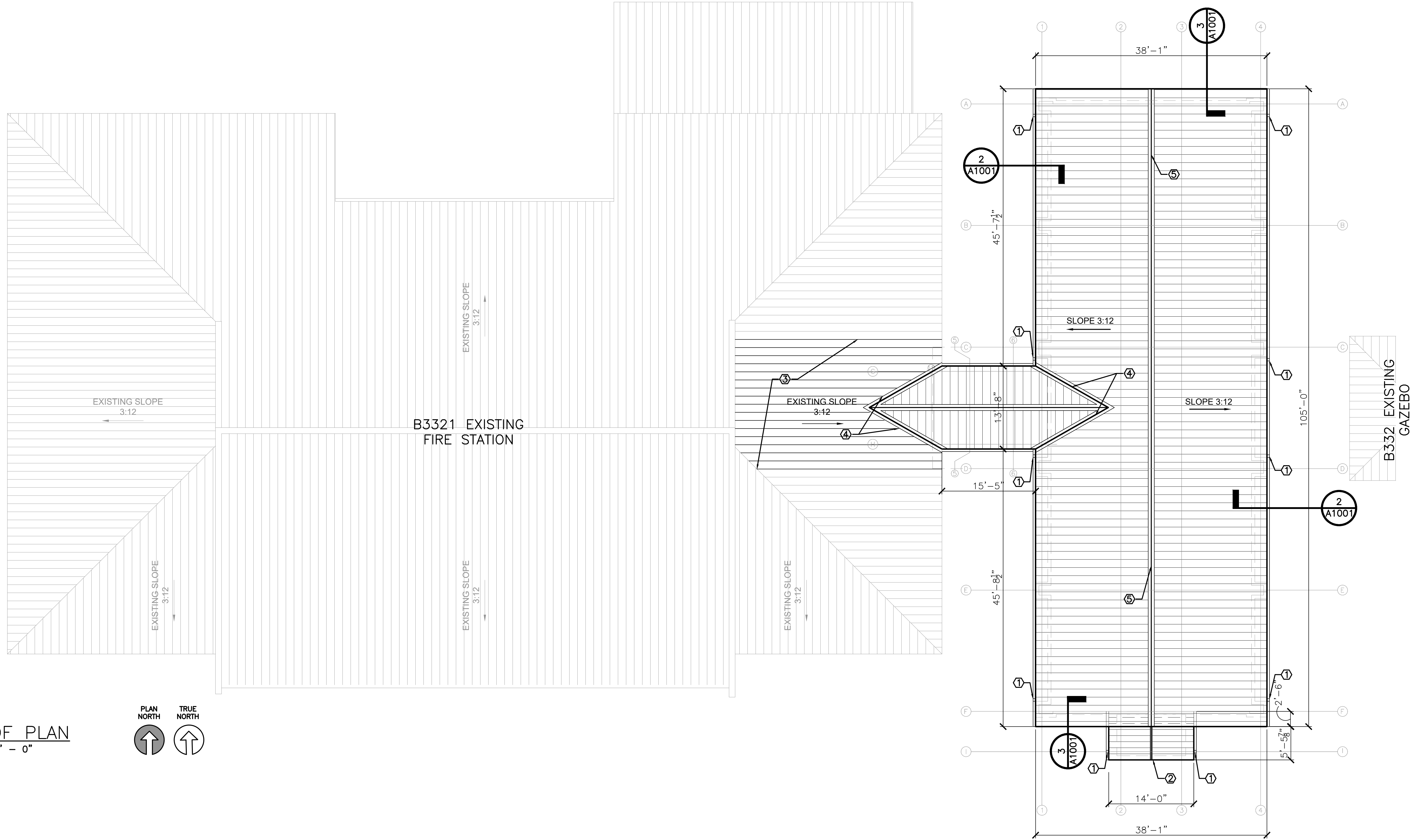

1 ROOF PLAN
 1/8" = 1' - 0"

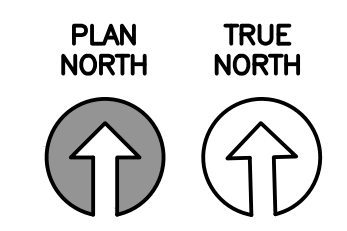

KEYNOTES

- CONTRACTOR SHALL PROVIDE NEW BOXED GUTTER AND DOWNSPOUTS. TRIM TO MATCH NEW MTL ROOF FINISH. RE: 2/A1001 FOR SOFFIT DTL.
- NEW MTL ROOF CANOPY BELOW
- CONTRACTOR SHALL PROVIDE NEW STANDING SEAM METAL ROOF PANELS TO MATCH EXISTING ROOF. COLOR MATCH TO EXISTING AS MUCH AS POSSIBLE. CONTRACTOR SHALL SEAL PENETRATIONS AND MODIFY EXISTING ROOF AS NEEDED FOR NEW BREEZEWAY.
- CONTRACTOR SHALL PROVIDE NEW ROOF VALLEY TRIM.
- CONTRACTOR SHALL PROVIDE NEW RIDGE CAP.

GENERAL NOTES

- CONTRACTOR SHALL BE RESPONSIBLE FOR VERIFYING EXISTING DIMENSIONS, EQUIPMENT, AND CONDITIONS PRIOR TO START OF WORK.
- THE CONTRACTOR SHALL TAKE APPROPRIATE STEPS TO PROTECT BUILDING

- ELEMENTS OUTSIDE THE SCOPE OF WORK AND LABELED AS "EXISTING TO REMAIN". DAMAGE TO THESE ITEMS REQUIRING REPAIR OR REPLACEMENT SHALL BE PERFORMED BY THE CONTRACTOR AT NO ADDITIONAL COST TO THE GOVERNMENT.
- CONTRACTOR SHALL COORDINATE WITH ALL OTHER TRADES.
 - CONTRACTOR SHALL ENSURE ALL SEAMS ARE WEATHERPROOFED AND SEALED PROPERLY.
 - CONTRACTOR SHALL PROVIDE CLOSURE STRIPS AND BUTYL TAPE PER MFR. RECOMMENDATIONS
 - CONTRACTOR SHALL PROVIDE FLASHING/SEALANT FOR THROUGH-ROOF PENETRATIONS PER MTL. BLDG. ROOF MFR RECOMMENDATIONS.
 - NEW STANDING SEAM MTL. ROOF TO MATCH EXISTING. SLOPE = 3 : 12 (2.7 : 12 @ BREEZEWAY).
 - CONTRACTOR SHALL PROVIDE RIDGE VENT W/COR-A-VENT LOW PROFILE FLOATING RIDGE VENT EQ. TO THAT BY RIGID GLOBAL BUILDINGS
 - CONTRACTOR SHALL PROVIDE THERMAL BLOCKS @ EA. PURLIN.

LEGEND

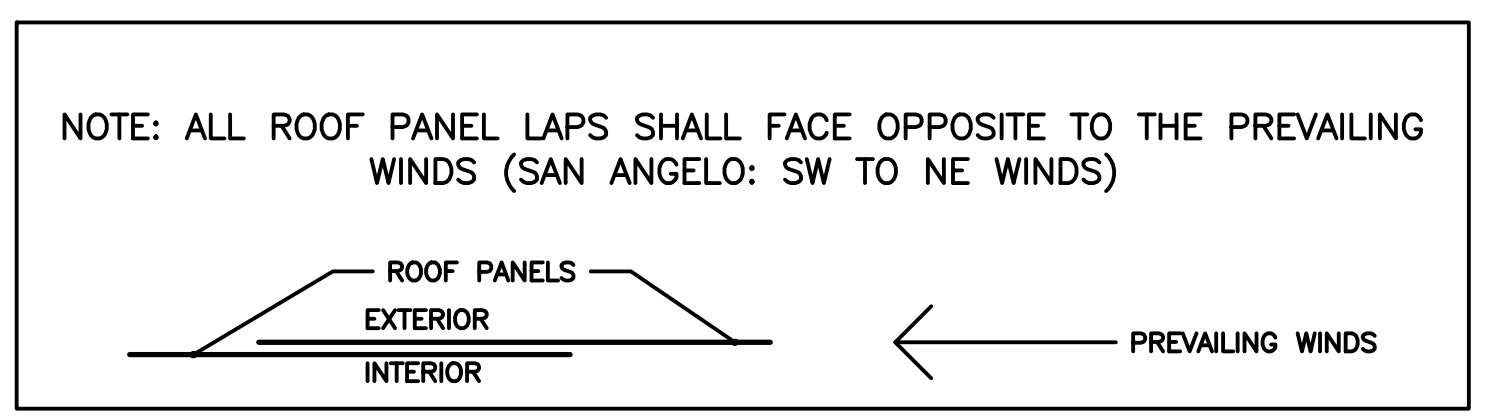
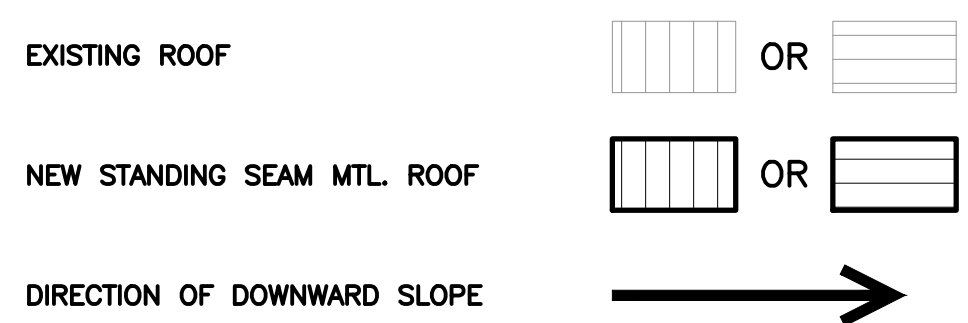

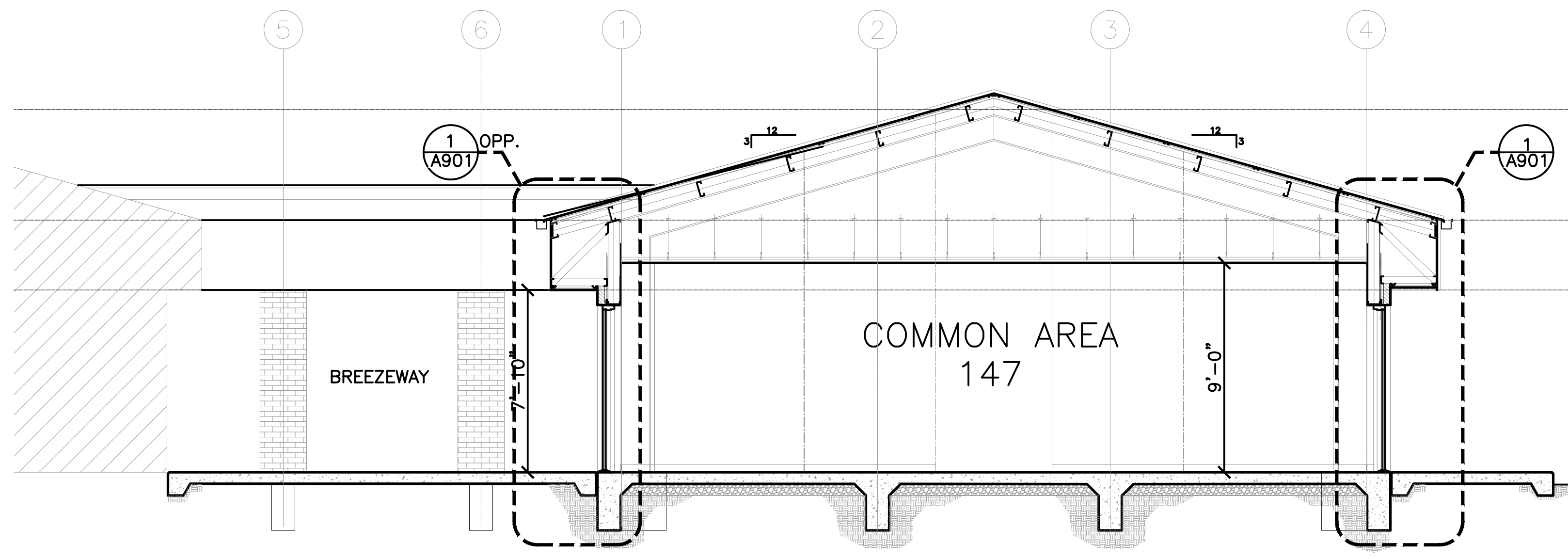
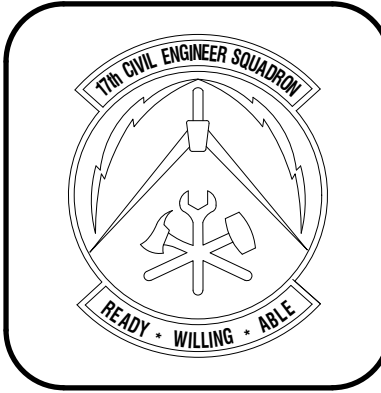

1 SECTION - THROUGH BREEZEWAY
1/4" = 1' - 0"

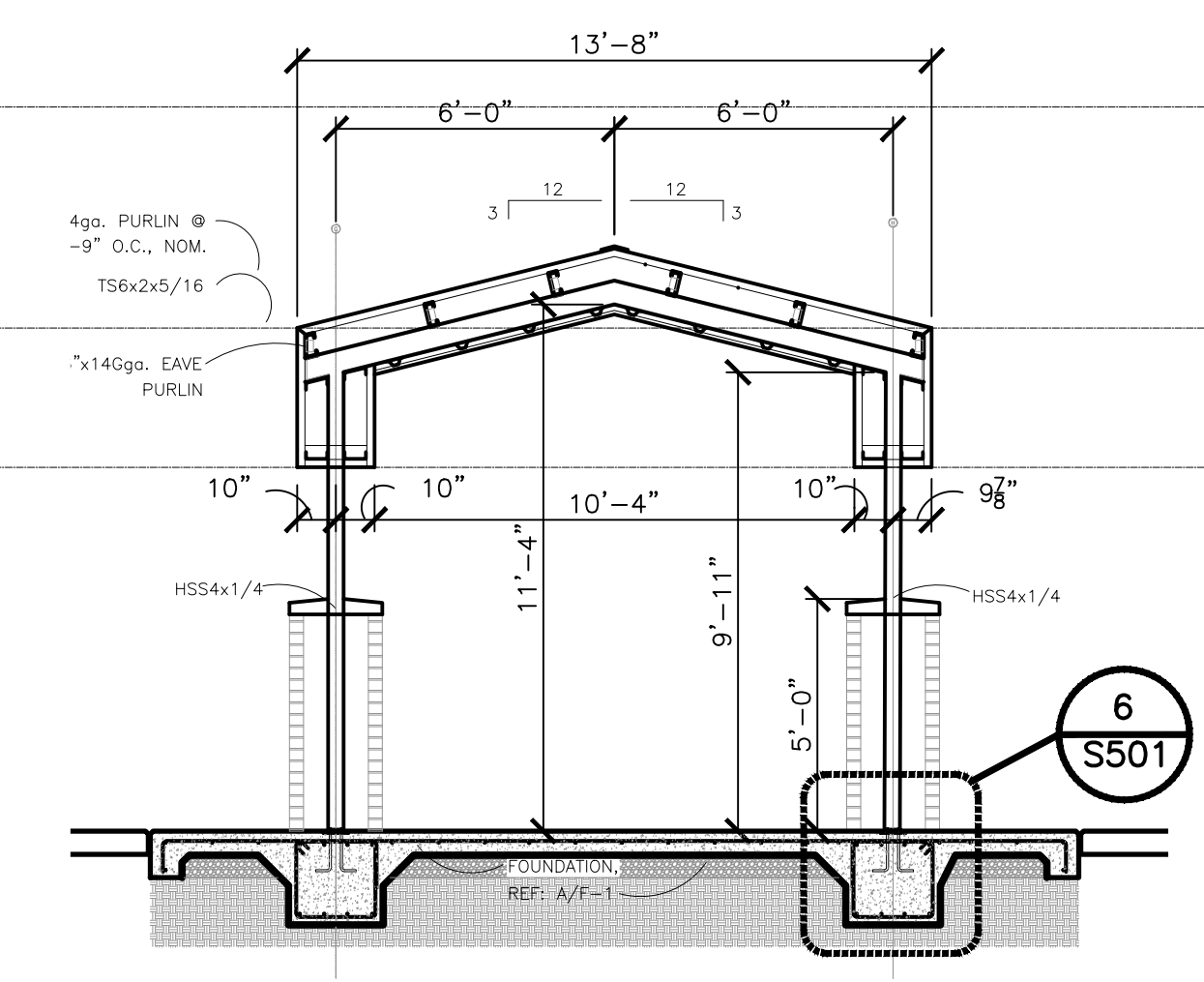

3 BREEZEWAY SECTION
1/4" = 1' - 0"

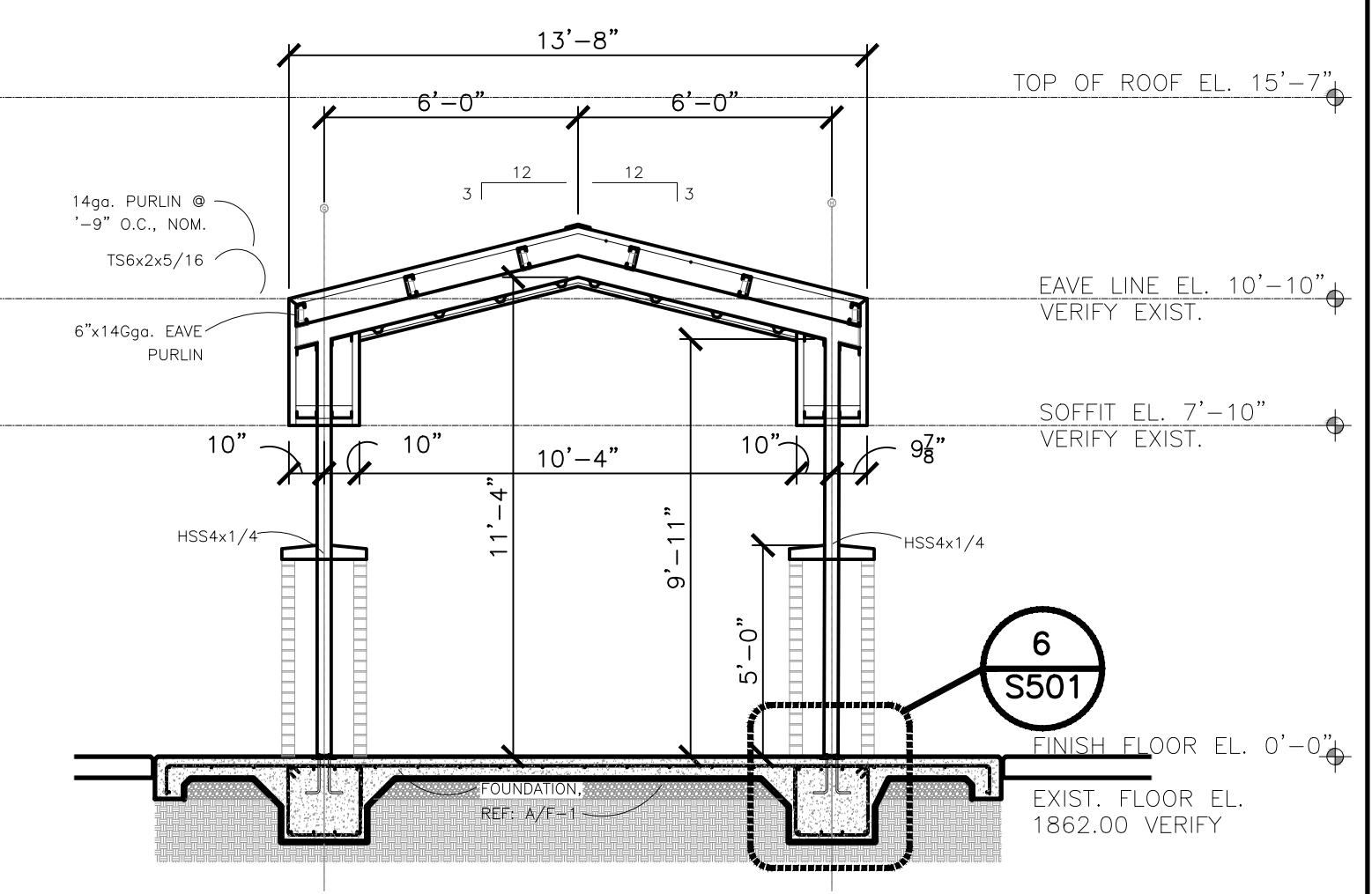

4 BREEZEWAY SECTION
1/4" = 1' - 0"

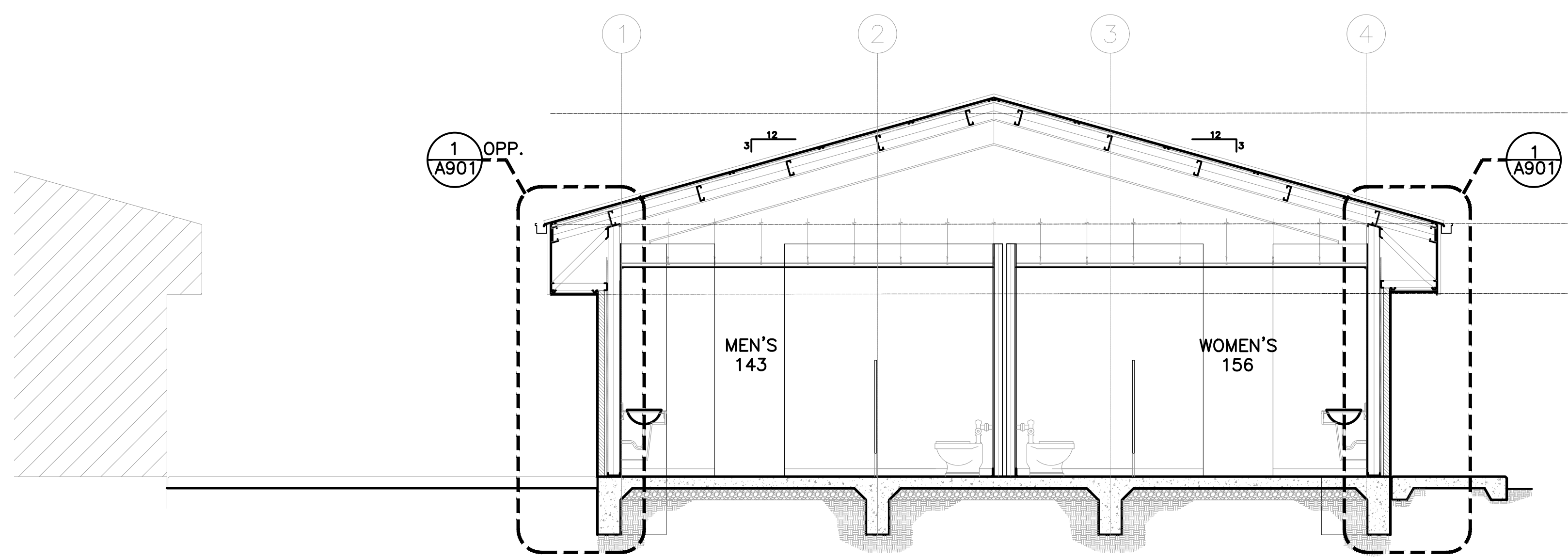

2 SECTION - THROUGH RESTROOMS
1/4" = 1' - 0"

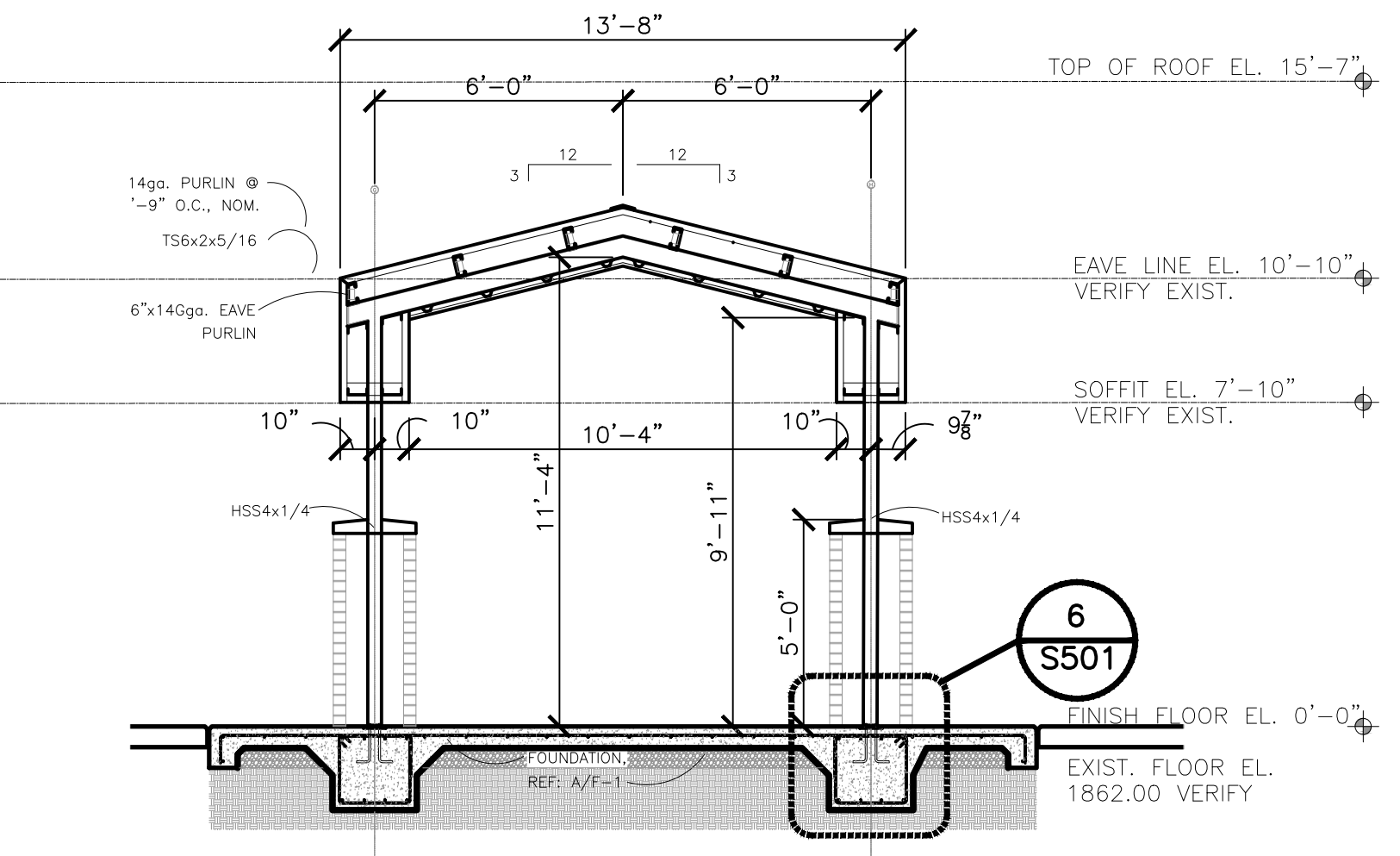

6 SECTION - THROUGH PORCH
1/4" = 1' - 0"

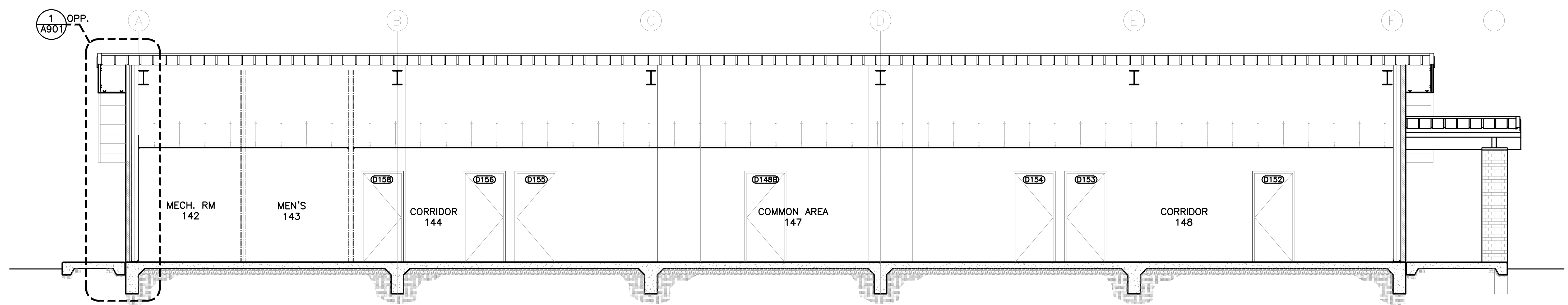

3 SECTION - LONGITUDINAL
1/4" = 1' - 0"

--	--	--	--	--	--	--	--	--	--

--	--	--	--	--	--	--	--	--	--

Designed by: JRM/MLA
Drawn by: JRM/MLA
Reviewed by: RTJ/AH
Submitted by: PCBS

PROJECT TITLE
**FIRE STATION ADD/ALTER, B3321
PROJECT NO. 1039839
17th TRAINING WING
GOODFELLOW AIR FORCE BASE, TEXAS**

Project Number:
1039839
SHEET TITLE
BUILDING SECTIONS
Date:
SEP 2023

SEQ. SHEET OF
18 **A-401** 50

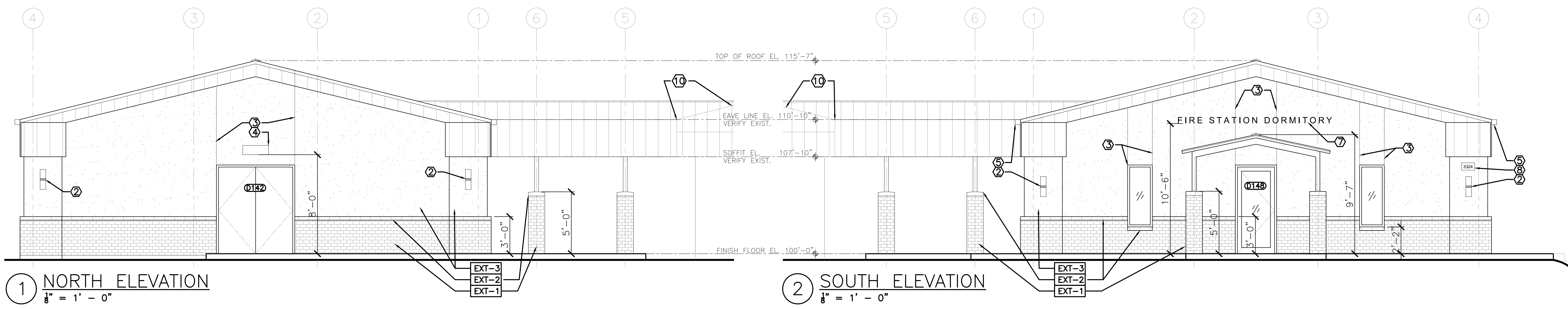
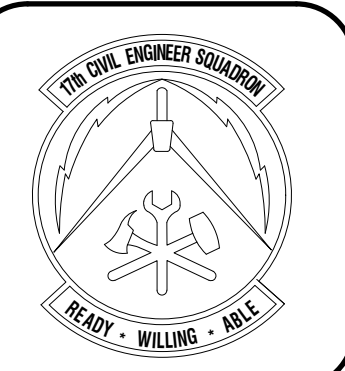

1 NORTH ELEVATION
1/8" = 1' - 0"

2 SOUTH ELEVATION
1/8" = 1' - 0"

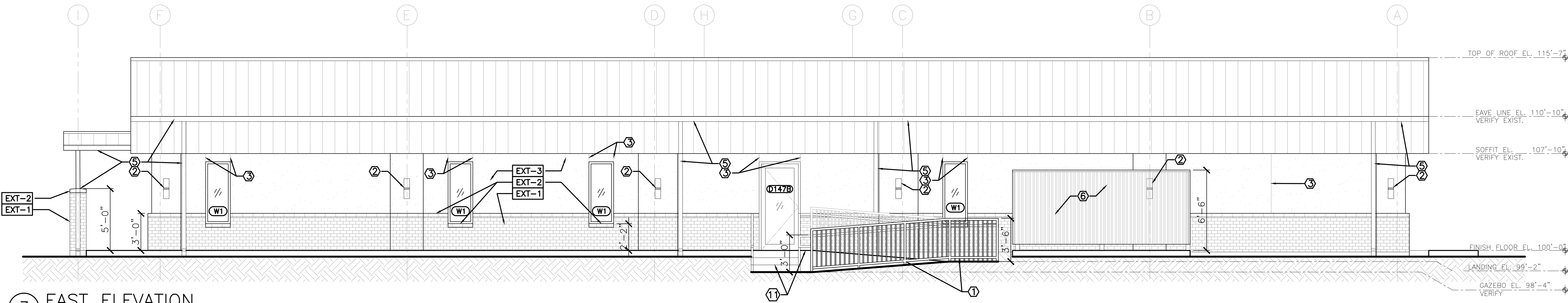

3 EAST ELEVATION
1/8" = 1' - 0"

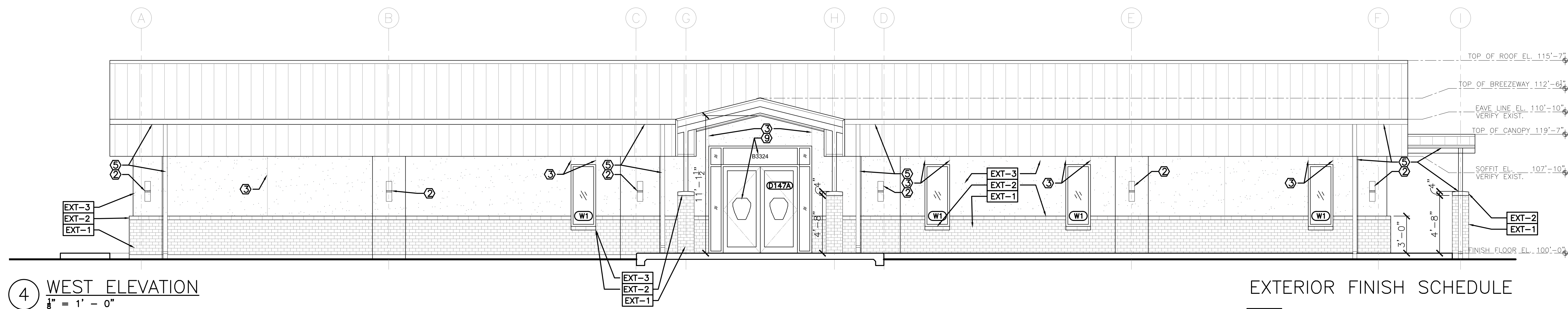

4 WEST ELEVATION
1/8" = 1' - 0"

- KEYNOTES** AS NOTATED BY
- CONTRACTOR SHALL PROVIDE STEEL PIPE HANDRAIL AND INSTALL PER ADA REQUIREMENTS. DK. BRONZE FINISH
 - CONTRACTOR SHALL PROVIDE NEW EXTERIOR SURFACE MOUNTED LED UP/DN WALL SCONCE. TYP. DK. BRONZE FINISH. CENTER BETWEEN EDGE OF SOFFIT AND CAST STONE CAP. REFER TO ELECTRICAL FOR SCHEDULE
 - NEW CONTROL JOINT. TYP
 - CONTRACTOR SHALL PROVIDE NEW EXTERIOR SURFACE MOUNTED LED WALL PACK. REFER TO ELECTRICAL.
 - CONTRACTOR SHALL PROVIDE 5" METAL DOWNSPOUT AND GUTTER. MEDIUM BRONZE FINISH TO MATCH METAL ROOF
 - CONTRACTOR SHALL PROVIDE NEW MECHANICAL ENCLOSURE AND PAD. PROVIDE NEW METAL "R" PANEL ENCLOSURE WITH DK BRONZE FINISH. PROVIDE EDGE

- TRIM FOR EXPOSED EDGES. REFER A/601 FOR ADDITIONAL INFORMATION.
- CONTRACTOR SHALL PROVIDE NEW EXTERIOR BUILDING ENTRANCE SIGNAGE IN ACCORDANCE WITH GAFB BASE STANDARDS AND RAISED ALUMINUM LETTERING, 6" HEIGHT. CENTER ABOVE PORCH CANOPY.
 - CONTRACTOR SHALL PROVIDE NEW EXTERIOR BUILDING SIGNAGE. BUILDING NUMBER TO BE DETERMINED. PROVIDED 3/8" ACRYLIC OR PAINTED ALUMINUM LETTERING WITH DK. BRONZE BACKGROUND AND WHITE LETTERING. REFER TO GAFB BASE STANDARDS.
 - CONTRACTOR SHALL PROVIDE FROSTED VINYL BUILDING ID NUMBER AND FIRE DEPT. EMBLEM ON GLASS STOREFRONT. FD EMBLEM AVAILABLE UPON REQUEST.
 - CONTRACTOR SHALL MODIFY EXISTING FIRE STATION ROOF TO ACCEPT NEW BREEZEWAY. CONTRACTOR SHALL FIELD VERIFY TYPE AND MATCH NEW.
 - NEW CONCRETE STAIRS AND RAMP. REFER TO A401 FOR ADDITIONAL INFORMATION.

GENERAL NOTES:

- CONTRACTOR SHALL VERIFY ALL DIMENSIONS AND JOB CONDITIONS PRIOR TO START OF WORK.
- CONTRACTOR SHALL PROVIDE ALL WEATHERPROOFING, FLASHING, AND SEALANTS AT ALL ROOF VALLEYS, AND INTERSECTIONS OF NEW CONSTRUCTION AND EXISTING CONNECTIONS.
- ALL METAL ROOF PANEL LAPS SHALL FACE OPPOSITE TO PREVAILING WINDS (SAN ANGELO: SW TO NE WINDS)

EXTERIOR FINISH SCHEDULE

EXT-1	FACE BRICK TO MATCH EXISTING FIRE STATION
EXT-2	CAST STONE CAP - WHITE OR LIMESTONE FINISH
EXT-3	CEMENT STUCCO - TAN FINISH TO MATCH FIRE STATION
D100	DOOR TAG
W1	WINDOW TAG

Designed by
JH/MLA
Drawn by
JH/MLA
Reviewed by
RT/JH
Submitted by
PCBS

FIRE STATION ADD/ALTER, B3321
PROJECT NO. 1039839
17th TRAINING WING
GOODFELLOW AIR FORCE BASE, TEXAS

PROJECT TITLE

Project Number:
1039839
SHEET TITLE
EXTERIOR ELEVATIONS
Date:
SEP 2023

SEQ. SHEET OF
24 A-501 50

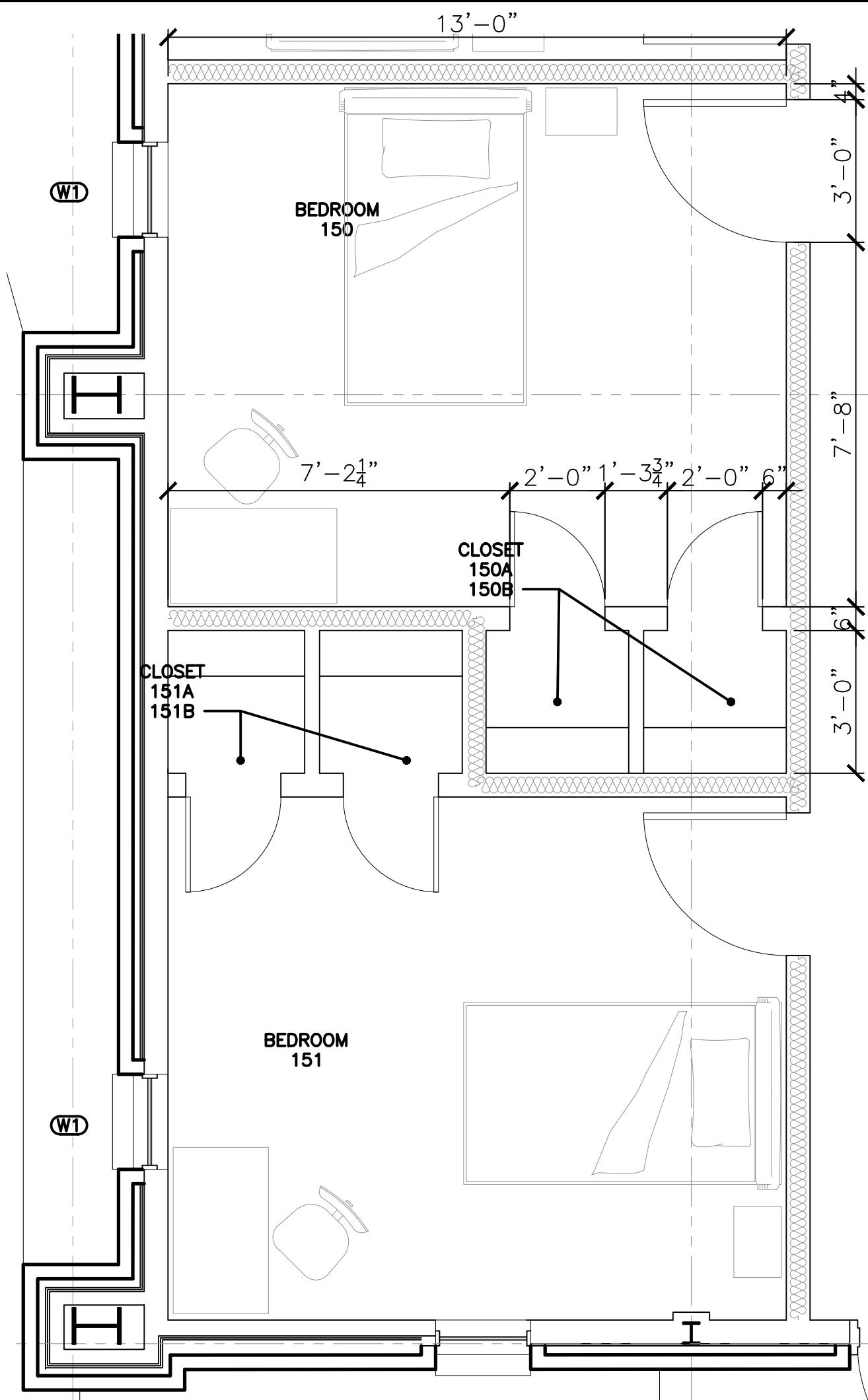

2 ENLARGED PLAN - TYP. DORM
 $\frac{3}{8}'' = 1' - 0''$

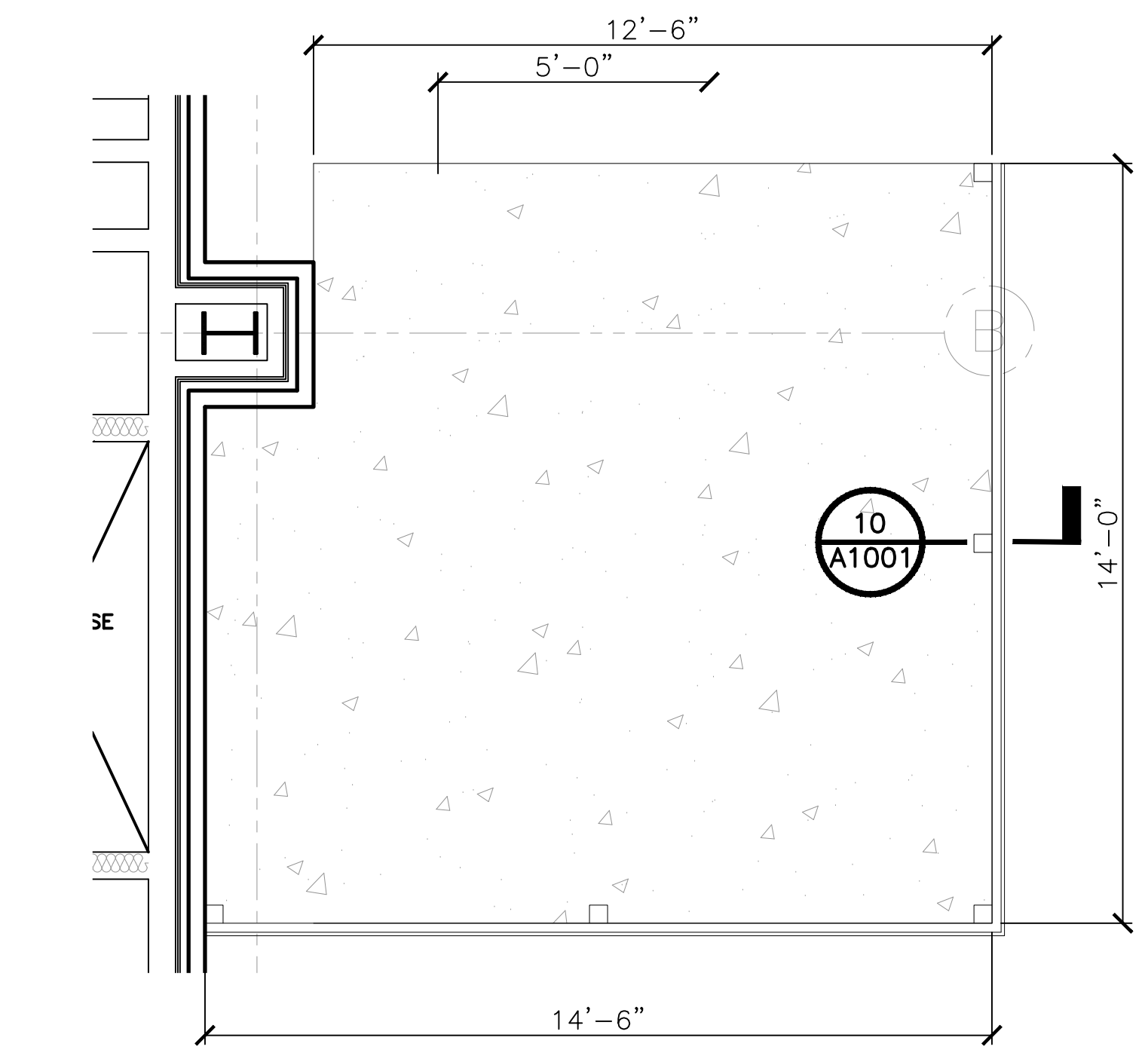

2 ENLARGED PLAN - HVAC ENCLOSURE
 $\frac{3}{8}'' = 1' - 0''$

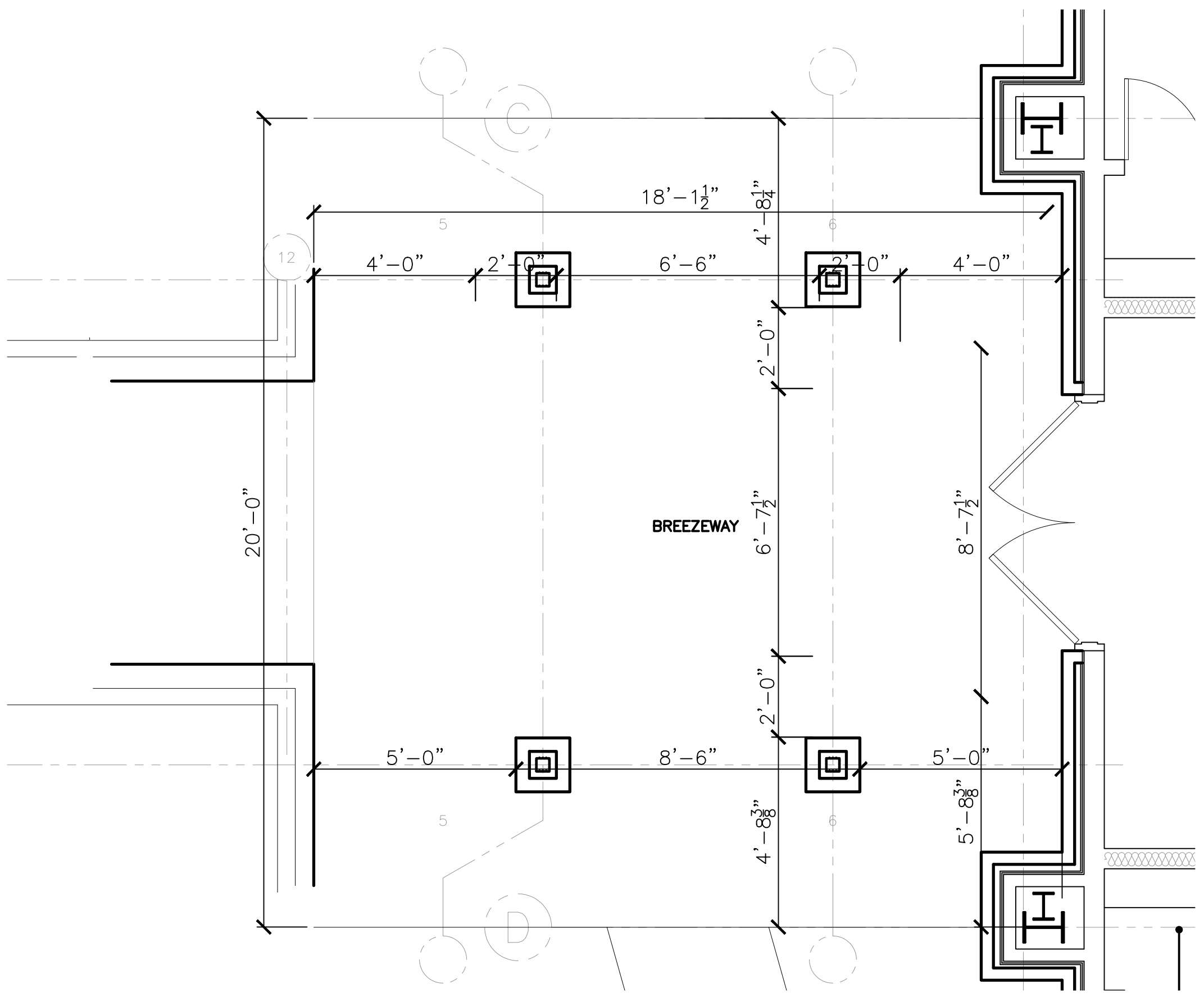

3 ENL. PLAN - BREEZEWAY
 $\frac{3}{8}'' = 1' - 0''$

LEGEND

- KEYNOTES
- INTERIOR ELEVATION RE: A701

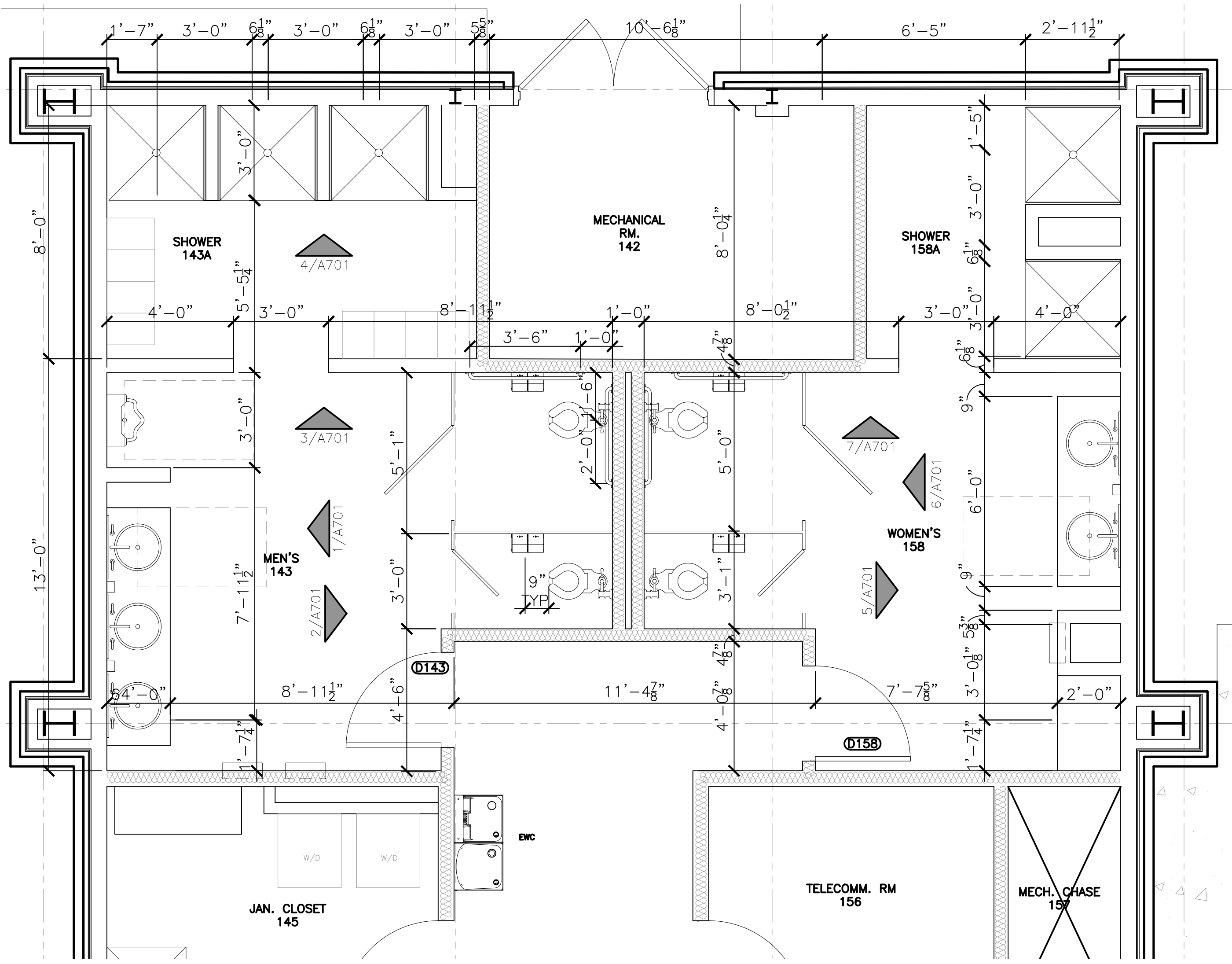
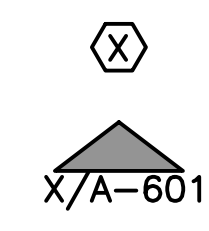

3 ENLARGED PLAN - RESTROOMS
 $\frac{3}{8}'' = 1' - 0''$

KEYNOTES AS INDICATED BY

- 1. N/A

GENERAL NOTES

- CONTRACTOR SHALL BE RESPONSIBLE FOR VERIFYING EXISTING DIMENSIONS, EQUIPMENT, AND CONDITIONS PRIOR TO START OF WORK.
- CONTRACTOR SHALL ENSURE WORK AREAS SHALL BE KEPT CLEAN, SAFE, AND IN A WORKMANLIKE CONDITION. DEBRIS SHALL BE CLEANED ON A DAILY BASIS AND SITE SHALL BE MAINTAINED IN ACCORDANCE WITH THE SPECIFICATIONS.
- THE CONTRACTOR SHALL TAKE APPROPRIATE STEPS TO PROTECT BUILDING ELEMENTS OUTSIDE THE SCOPE OF WORK AND LABELED AS "EXISTING TO REMAIN". DAMAGE TO THESE ITEMS REQUIRING REPAIR OR REPLACEMENT SHALL BE PERFORMED BY THE CONTRACTOR AT NO ADDITIONAL COST TO THE GOVERNMENT.
- CONTRACTOR SHALL COORDINATE WITH ALL OTHER TRADES.
- CONTRACTOR SHALL DEMOLISH ALL ITEMS NOT SPECIFICALLY INDICATED, BUT OBVIOUSLY AND/OR NORMALLY REQUIRED TO COMPLETELY AND PROPERLY EXECUTE THE DEMOLITION WORK.
- FOR UNDER-SLAB DEMO, CONTRACTOR SHALL DEMO THE MINIMUM NECESSARY CONCRETE TO PROVIDE FOR NEW PLUMBING INSTALLATION.

TOILET ACCESSORY SCHEDULE (OR APPROVED EQUAL)			
TAG #	NAME	MANUFACTURER	NOTES
TA-1	TOILET PAPER DISPENSER	KOALA KARE	GFCI - GOV'T FURNISHED CONTRACTOR INSTALLED
TA-2	SOAP DISPENSER	KOALA KARE	GFCI - GOV'T FURNISHED CONTRACTOR INSTALLED
TA-3	PAPER TOWEL DISPENSER	KOALA KARE	GFCI - GOV'T FURNISHED CONTRACTOR INSTALLED
TA-4	24" X 36" GLASS MIRROR	BOBRICK #B-3942	GFCI - CONTRACTOR FURNISHED & INSTALLED
TA-5	GRAB BAR, 36"	BOBRICK #B-5806 X 36	CFCI - CONTRACTOR FURNISHED & INSTALLED
TA-6	GRAB BAR, 42"	BOBRICK #B-5806 X 42	CFCI - CONTRACTOR FURNISHED & INSTALLED
TA-7	WASTE RECEPTACLE	BOBRICK #B-2400	CFCI - CONTRACTOR FURNISHED & INSTALLED
TA-8	SHOWER CURTAIN AND HOOKS		CFCI - CONTRACTOR FURNISHED & INSTALLED
TA-9	SHOWER CURTAIN		CFCI - CONTRACTOR FURNISHED & INSTALLED

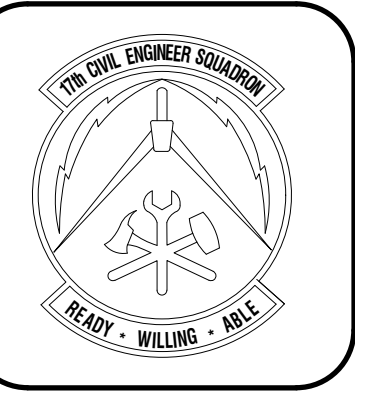

DESIGNED BY JH/MLLA
CHECKED BY JH/MLLA
REVIEWED BY RT/JAF
SUBMITTED BY PCBS

PROJECT TITLE FIRE STATION ADD/ALTER, B3321 PROJECT NO. 1039839 17th TRAINING WING GOODFELLOW AIR FORCE BASE, TEXAS

PROJECT TITLE FIRE STATION ADD/ALTER, B3321 PROJECT NO. 1039839 17th TRAINING WING GOODFELLOW AIR FORCE BASE, TEXAS
PROJECT NUMBER 1039839
SHEET TITLE ENLARGED PLANS
DATE SEP 2023
SEQ. SHEET OF 25 A-601 50

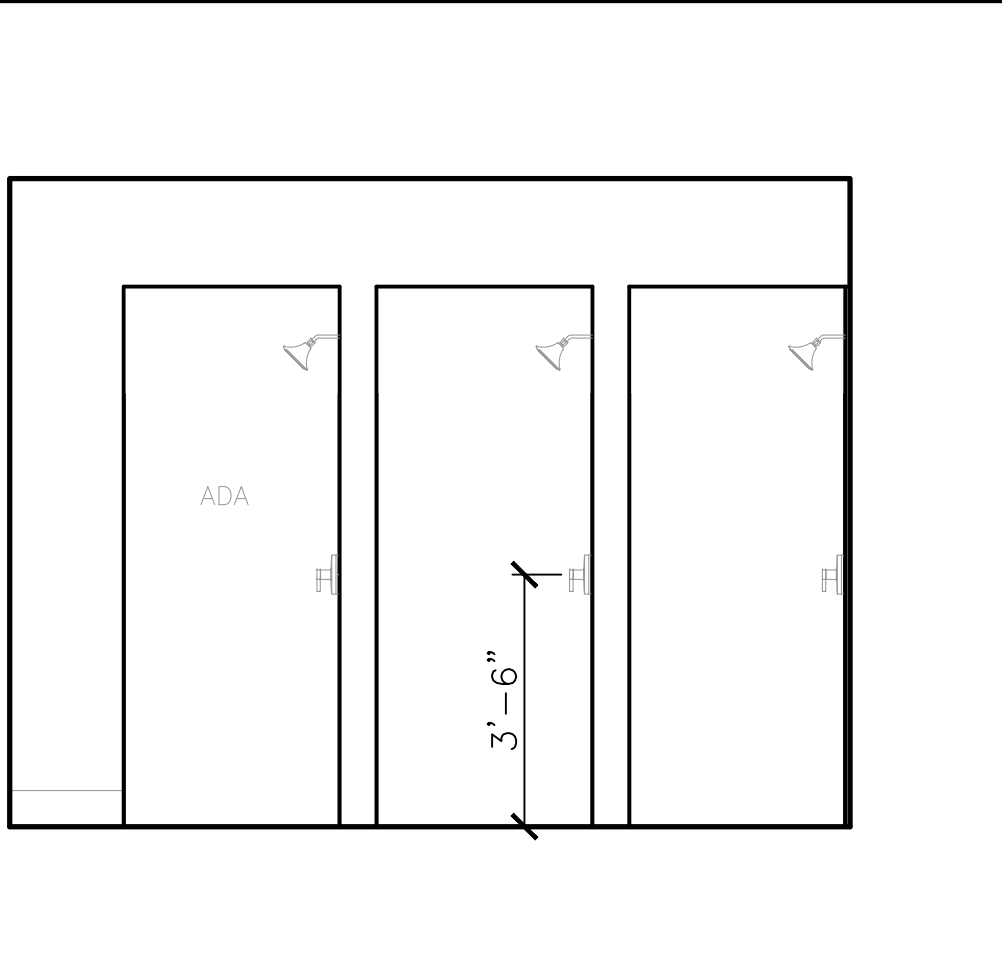
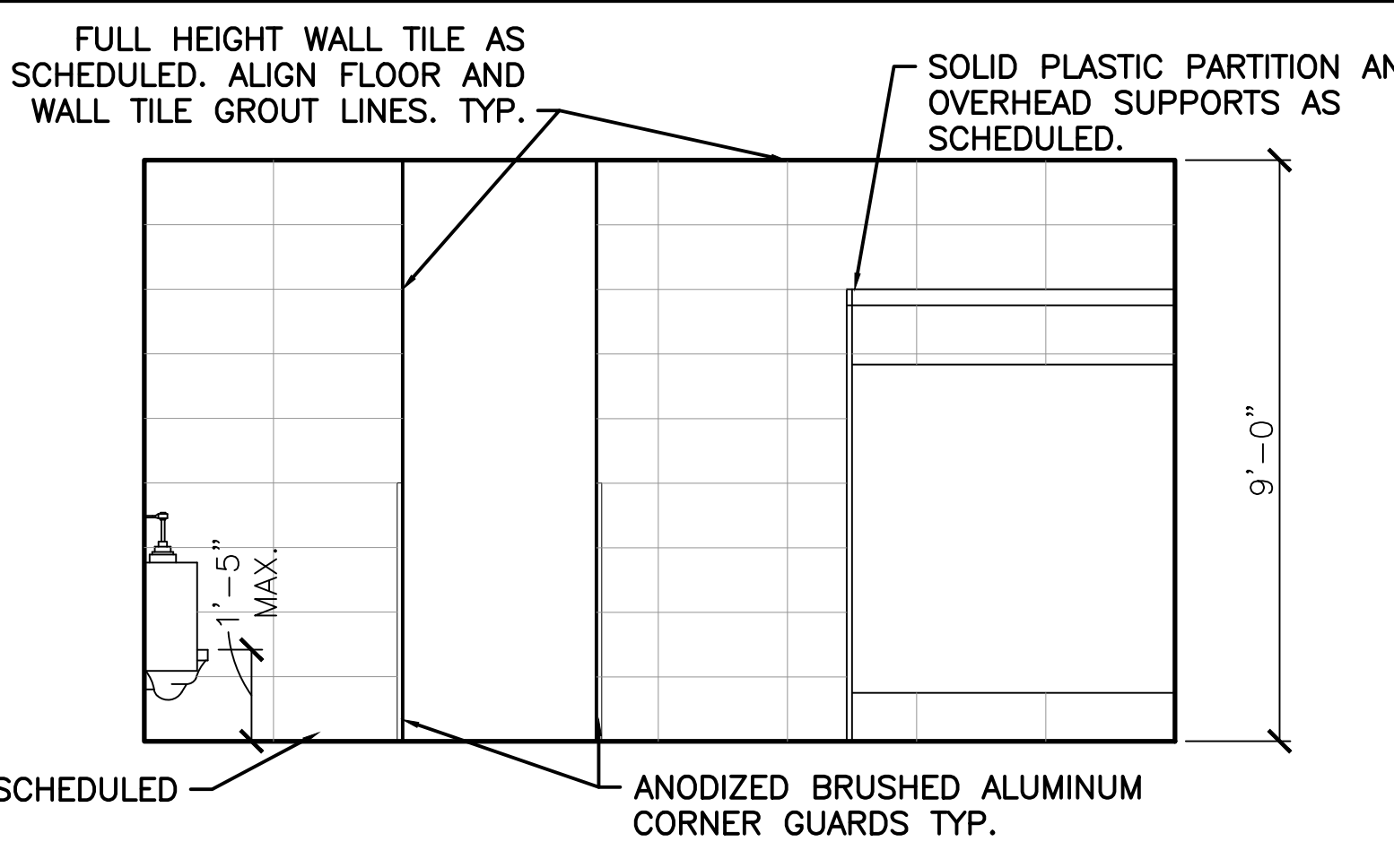
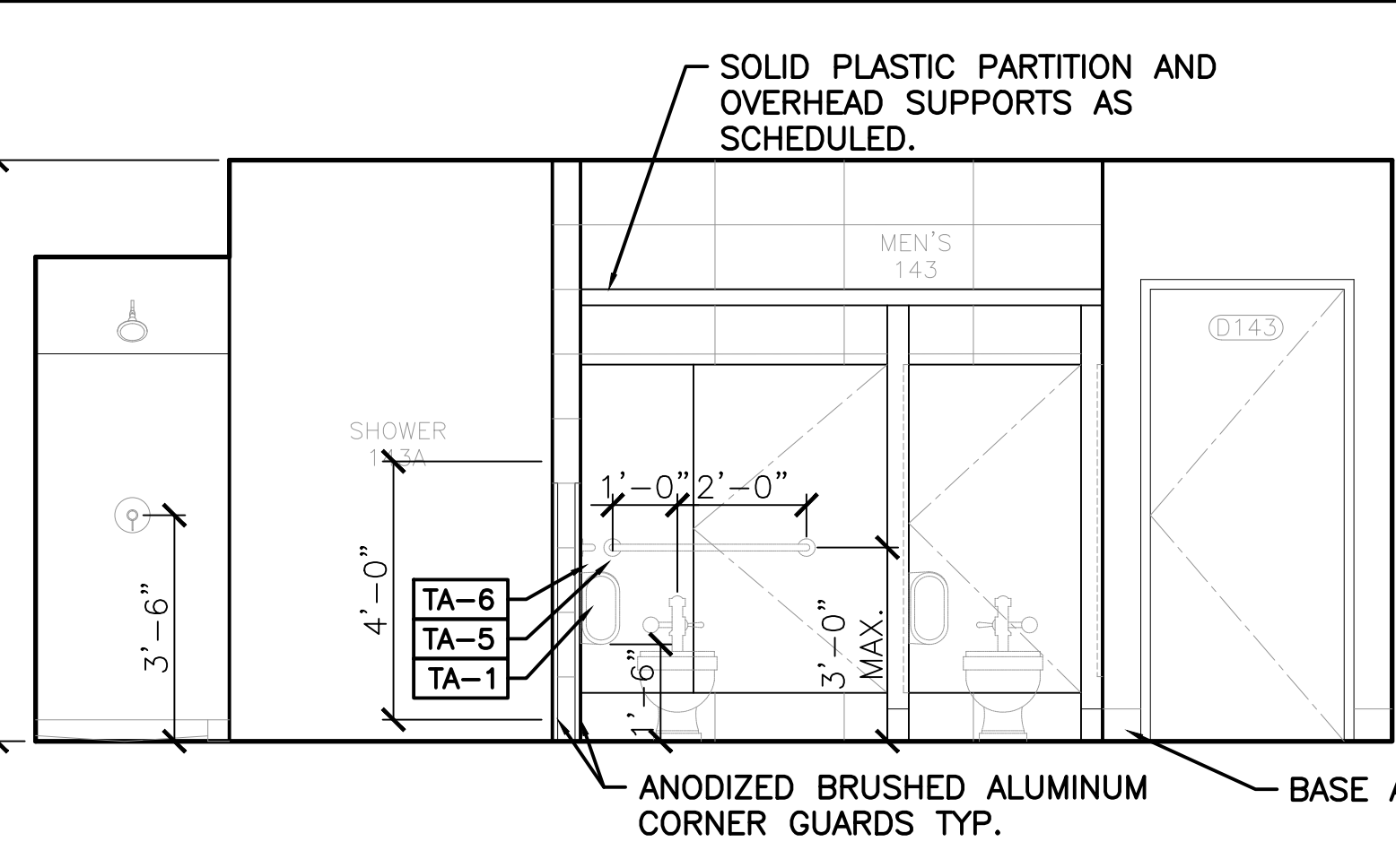
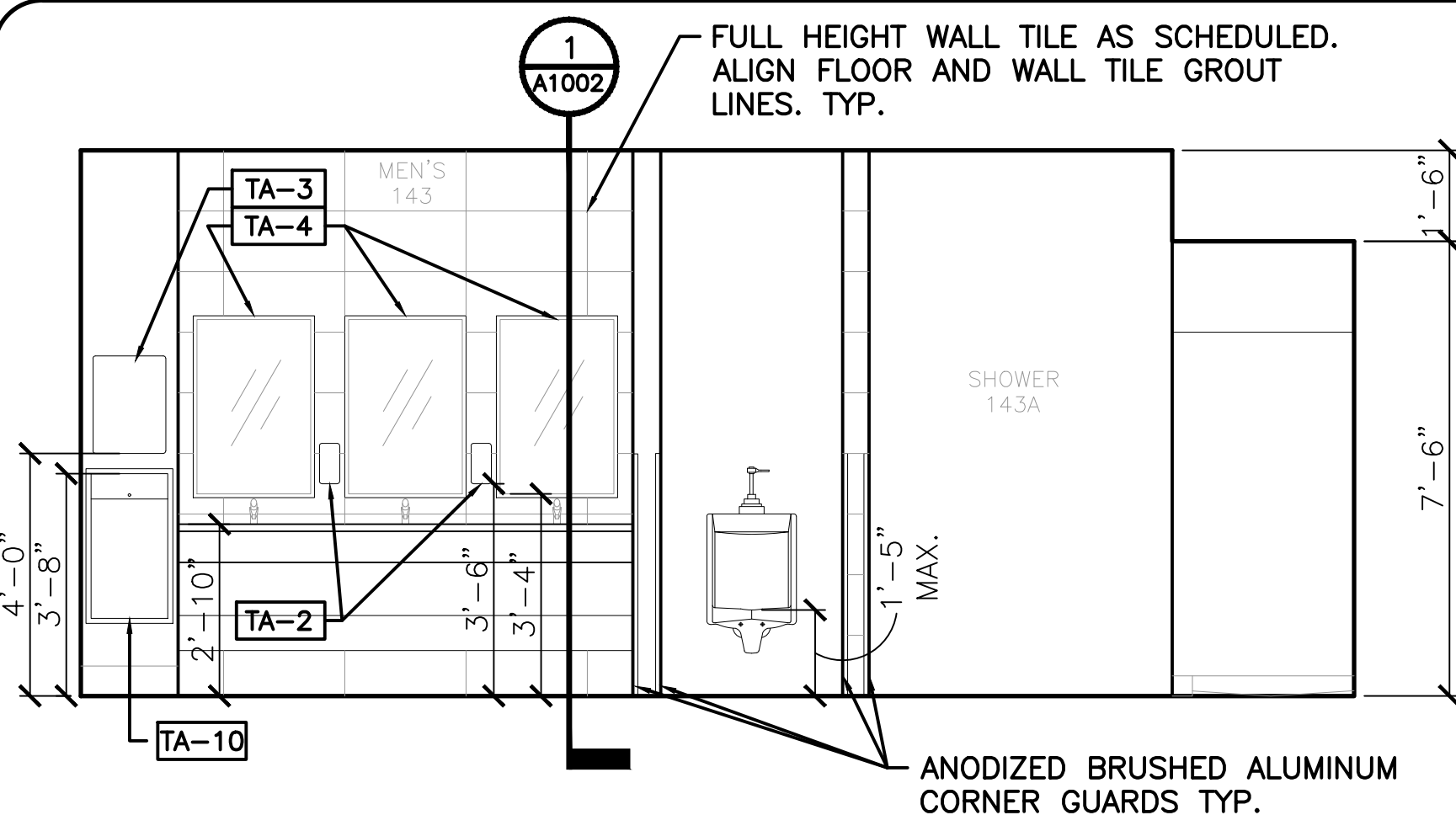
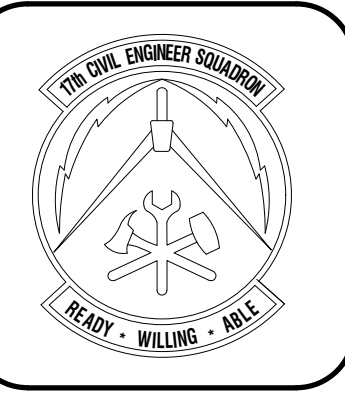

1 INT. ELEVATION-MEN'S RR
3/8" = 1'-0"

2 INT. ELEVATION-MEN'S RR
3/8" = 1'-0"

3 INT. ELEVATION-MEN'S RR
3/8" = 1'-0"

4 INT. ELEVATION-MEN'S RR
3/8" = 1'-0"

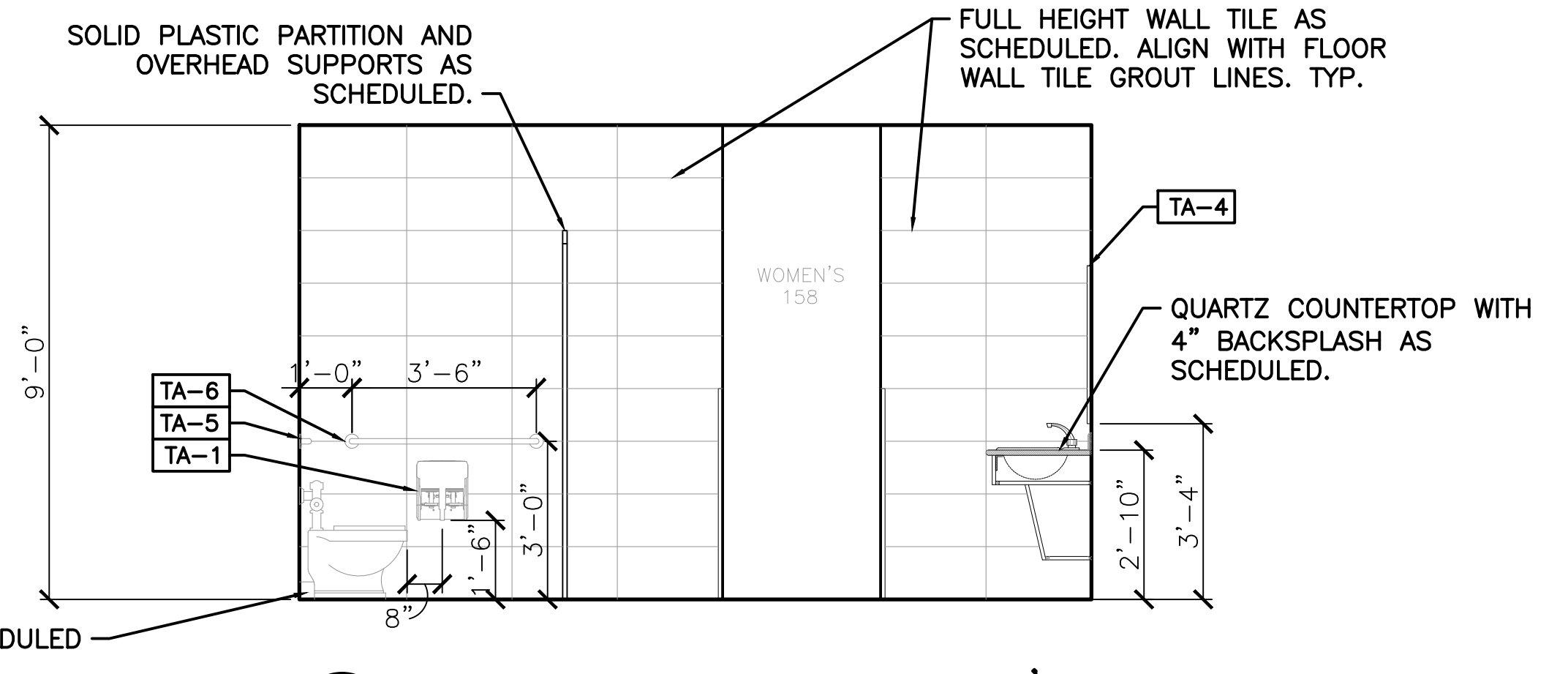
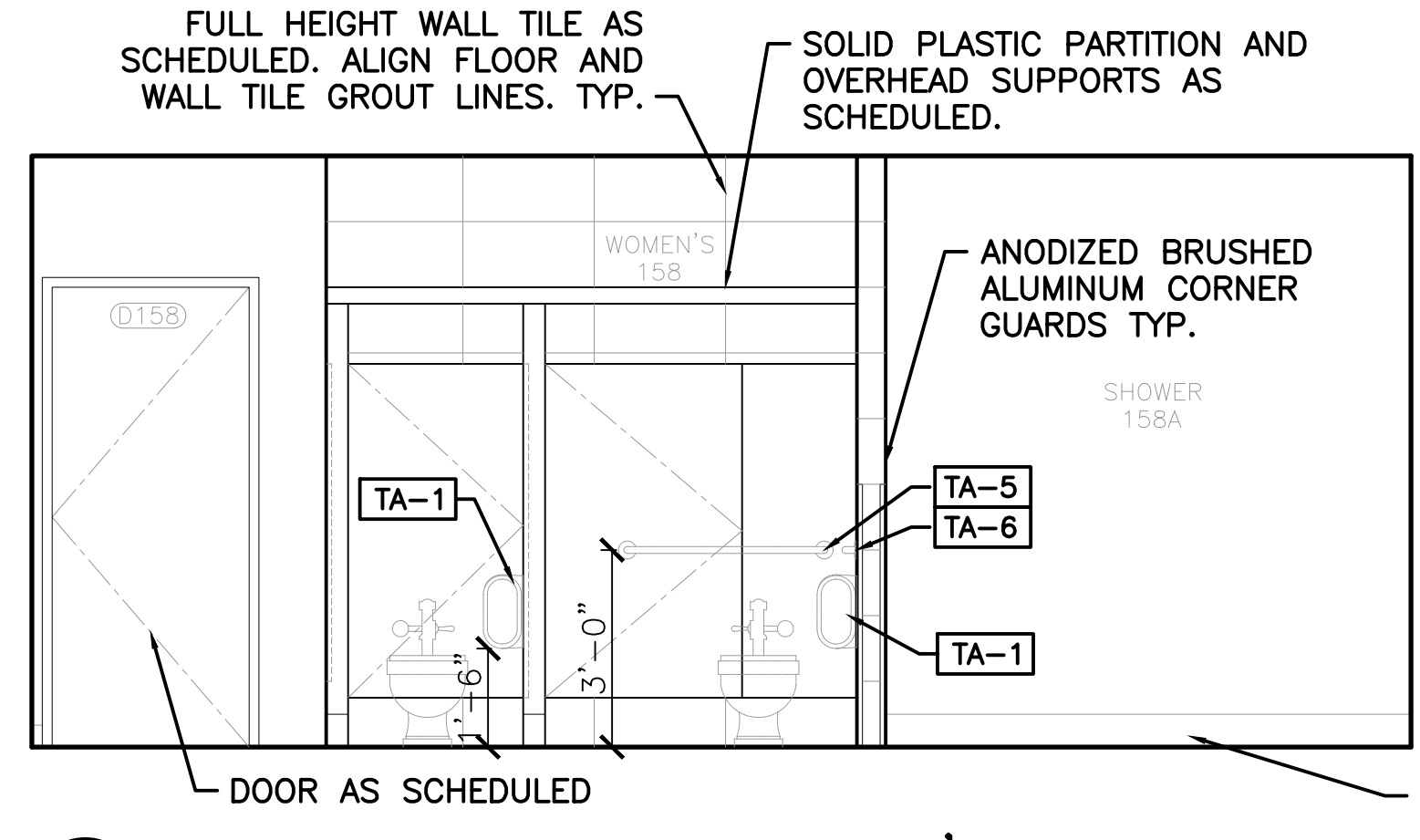
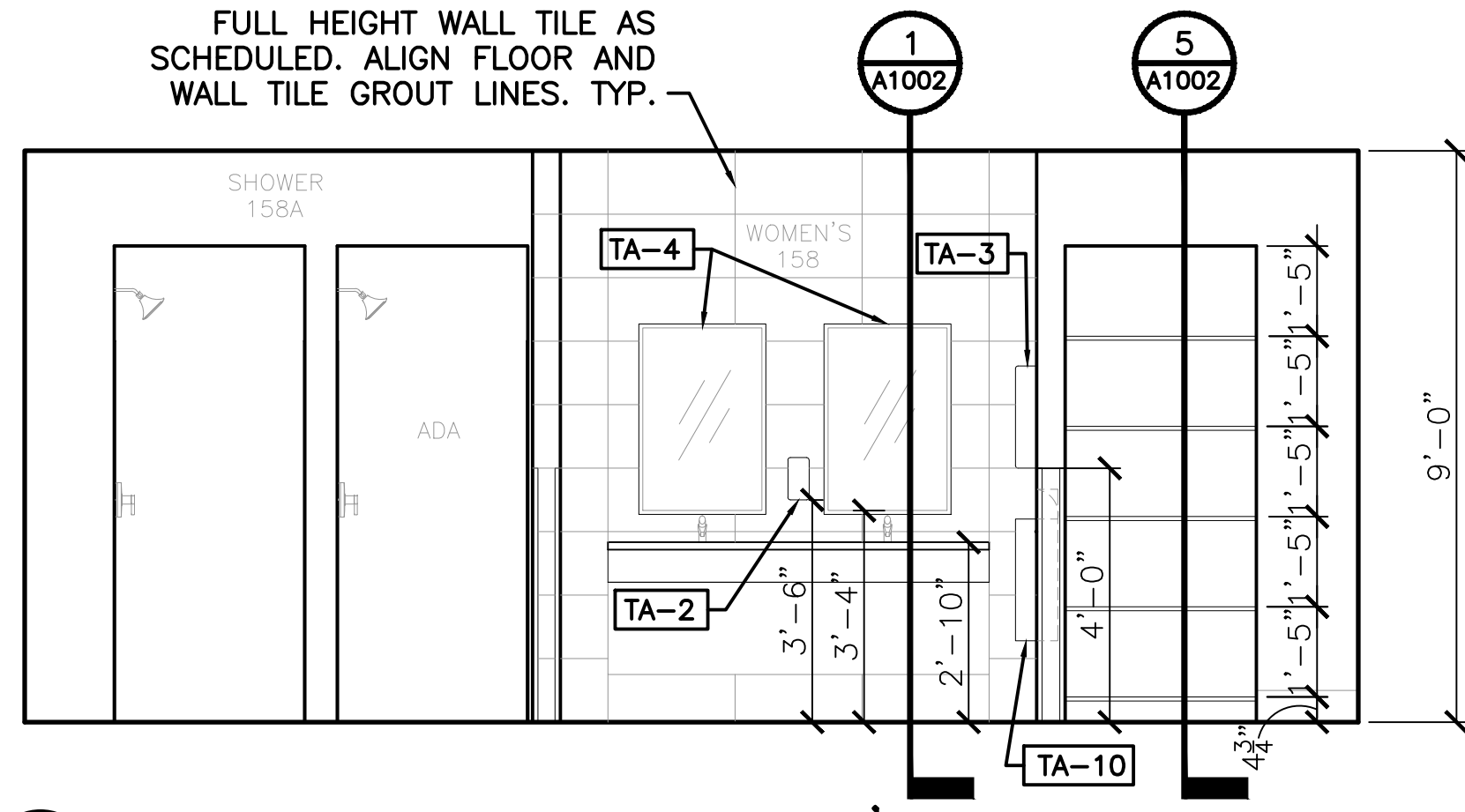

5 INT. ELEVATION-WOMEN'S RR
3/8" = 1'-0"

6 INT. ELEVATION-WOMEN'S RR
3/8" = 1'-0"

7 INT. ELEVATION-WOMEN'S RR
3/8" = 1'-0"

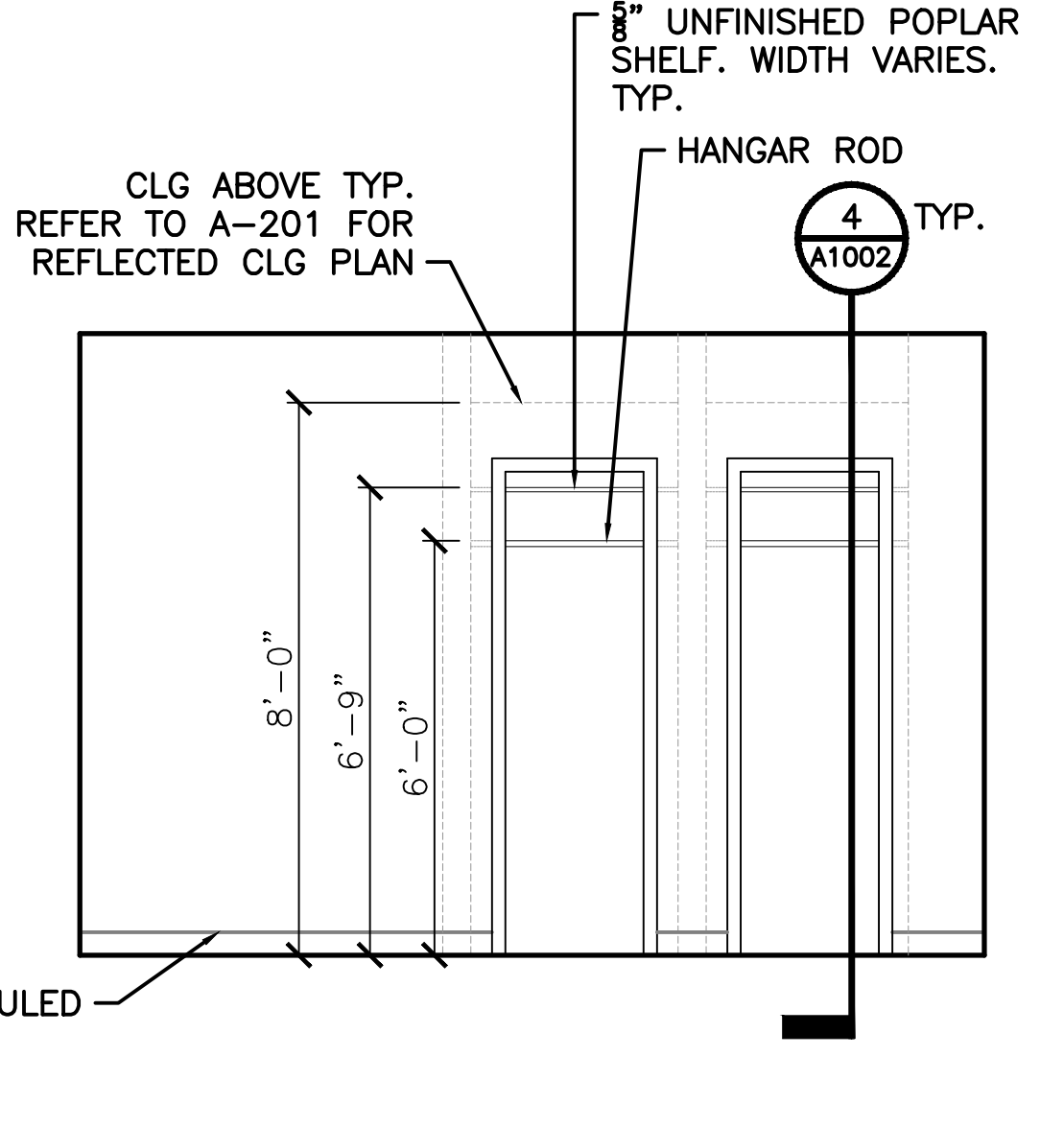
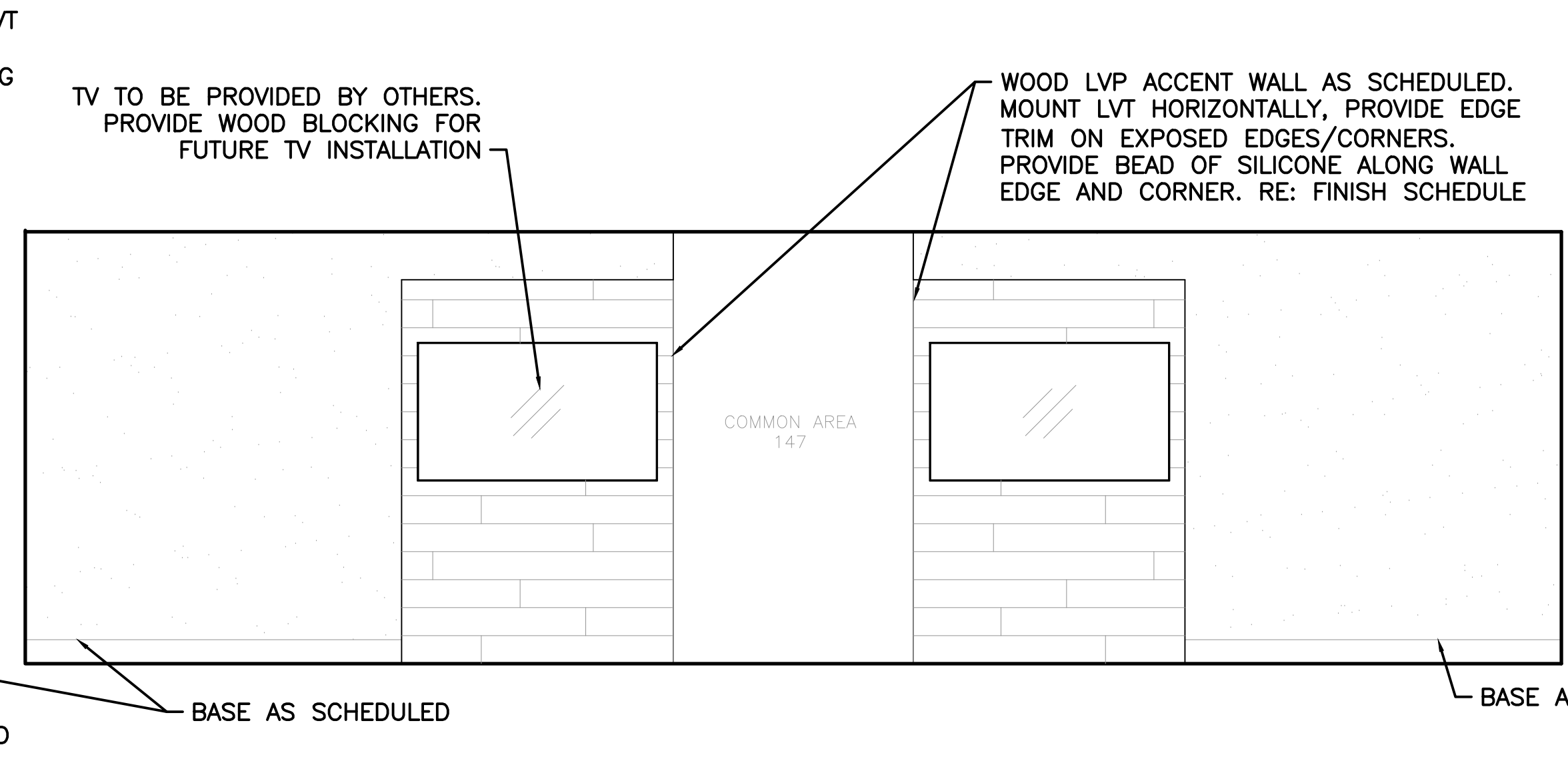
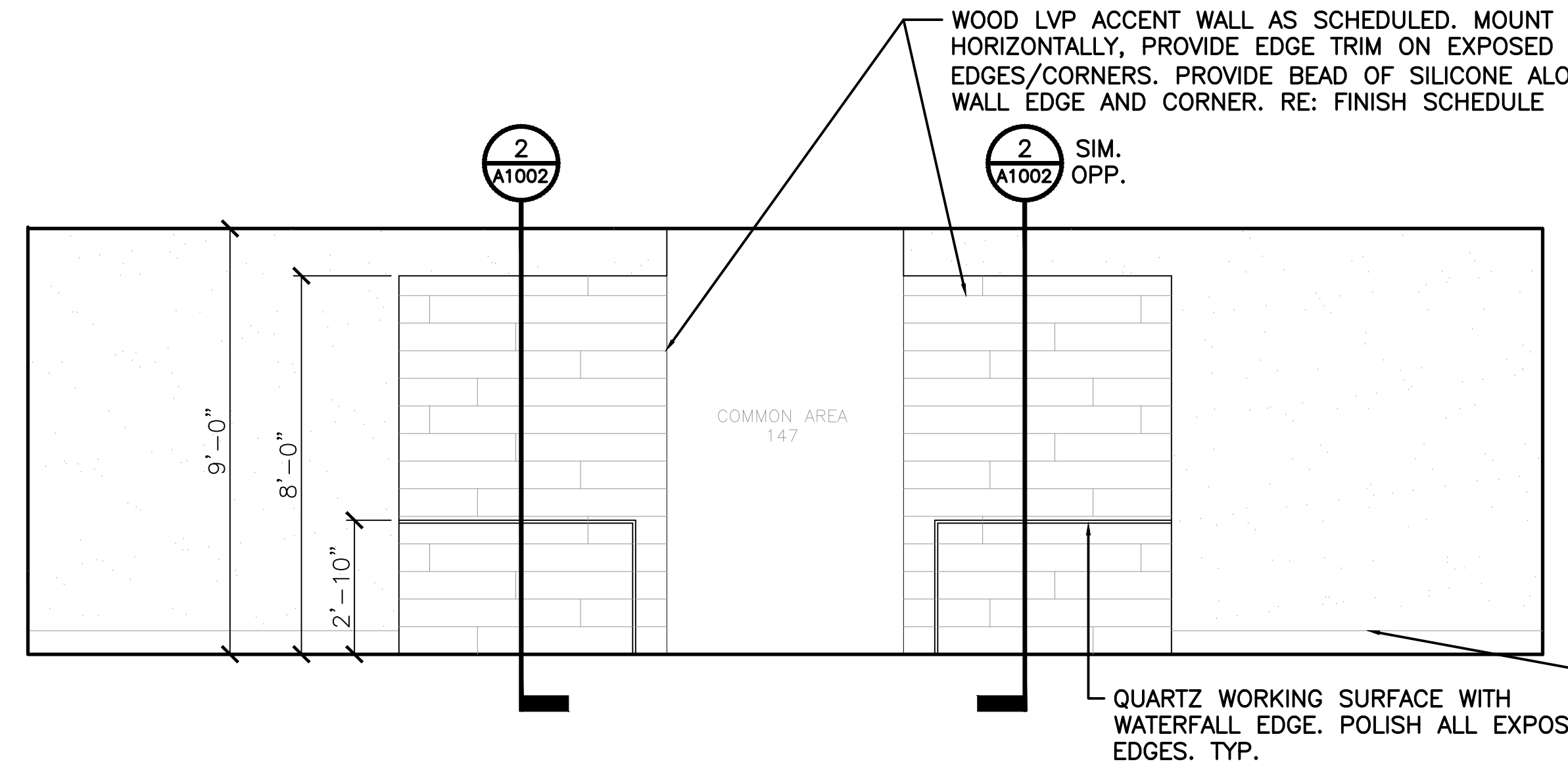

8 INT. ELEVATION - COMMON RM.
3/8" = 1'-0"

9 INT. ELEVATION - COMMON RM.
3/8" = 1'-0"

10 TYP. DORM CLOSET
3/8" = 1'-0"

GENERAL NOTES

- CONTRACTOR SHALL BE RESPONSIBLE FOR VERIFYING EXISTING DIMENSIONS, EQUIPMENT, AND CONDITIONS PRIOR TO START OF WORK.
- CONTRACTOR SHALL ENSURE WORK AREAS SHALL BE KEPT CLEAN, SAFE, AND IN A WORKMANLIKE CONDITION. DEBRIS SHALL BE CLEANED ON A DAILY BASIS AND SITE SHALL BE MAINTAINED IN ACCORDANCE WITH THE SPECIFICATIONS.
- THE CONTRACTOR SHALL TAKE APPROPRIATE STEPS TO PROTECT BUILDING ELEMENTS OUTSIDE THE SCOPE OF WORK AND LABELED AS "EXISTING TO REMAIN". DAMAGE TO THESE ITEMS REQUIRING REPAIR OR REPLACEMENT SHALL BE PERFORMED BY THE CONTRACTOR AT NO ADDITIONAL COST TO THE GOVERNMENT.
- CONTRACTOR SHALL COORDINATE WITH ALL OTHER TRADES.
- CONTRACTOR SHALL DEMOLISH ALL ITEMS NOT SPECIFICALLY INDICATED, BUT OBVIOUSLY AND/OR NORMALLY REQUIRED TO COMPLETELY AND PROPERLY EXECUTE THE DEMOLITION WORK.
- FOR UNDER-SLAB DEMO, CONTRACTOR SHALL DEMO THE MINIMUM NECESSARY CONCRETE TO PROVIDE FOR NEW PLUMBING INSTALLATION.

TOILET ACCESSORY SCHEDULE (OR APPROVED EQUAL)				
TAG #	NAME	MANUFACTURER	MODEL	NOTES
TA-1	TOILET PAPER DISPENSER	GEORGIA PACIFIC	COMPACT, MFG #56744A	CFCI - CONTRACTOR FURNISHED & INSTALLED
TA-2	SOAP DISPENSER	SC JOHNSON	PROLINE CURVE, #BLK2LDP	CFCI - CONTRACTOR FURNISHED & INSTALLED
TA-3	PAPER TOWEL DISPENSER	TORK	PEAKSERVE MINI CONTINUOUS, #552538	CFCI - CONTRACTOR FURNISHED & INSTALLED
TA-4	24" X 36" GLASS MIRROR	BOBRICK	#B-3942	CFCI - CONTRACTOR FURNISHED & INSTALLED
TA-5	GRAB BAR, 36"	BOBRICK	#B-5806 X 36	CFCI - CONTRACTOR FURNISHED & INSTALLED
TA-6	GRAB BAR, 42"	BOBRICK	#B-5806 X 42	CFCI - CONTRACTOR FURNISHED & INSTALLED
TA-7	WASTE RECEPTACLE	BOBRICK	#B-2400	CFCI - CONTRACTOR FURNISHED & INSTALLED
TA-8	SHOWER ROD & FLANGE	ASI	#1204-36/1204-1	CFCI - CONTRACTOR FURNISHED & INSTALLED
TA-9	SHOWER CURTAIN & HOOKS	ASI	#1200-V36/1200-SHU	CFCI - CONTRACTOR FURNISHED & INSTALLED
TA-10	WASTE RECEPTACLE	BOBRICK	RECESSED, SATIN FINISH, #B-3644	CFCI - CONTRACTOR FURNISHED & INSTALLED

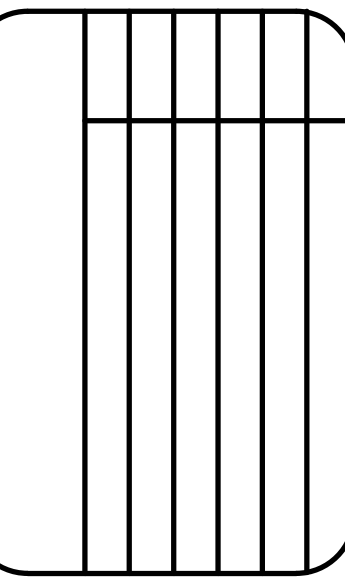

Designed by: JH/ML/A
 Drawn by: JH/ML/A
 Reviewed by: RTI/AH
 Submitted by: PC/ES

PROJECT TITLE
FIRE STATION ADD/ALTER, B3321
PROJECT NO. 1039839
17th TRAINING WING
GOODFELLOW AIR FORCE BASE, TEXAS

Project Number:
1039839
 SHEET TITLE
INTERIOR ELEVATIONS
 Date:
SEP 2023

SEQ. SHEET OF
 26 **A-701** 50

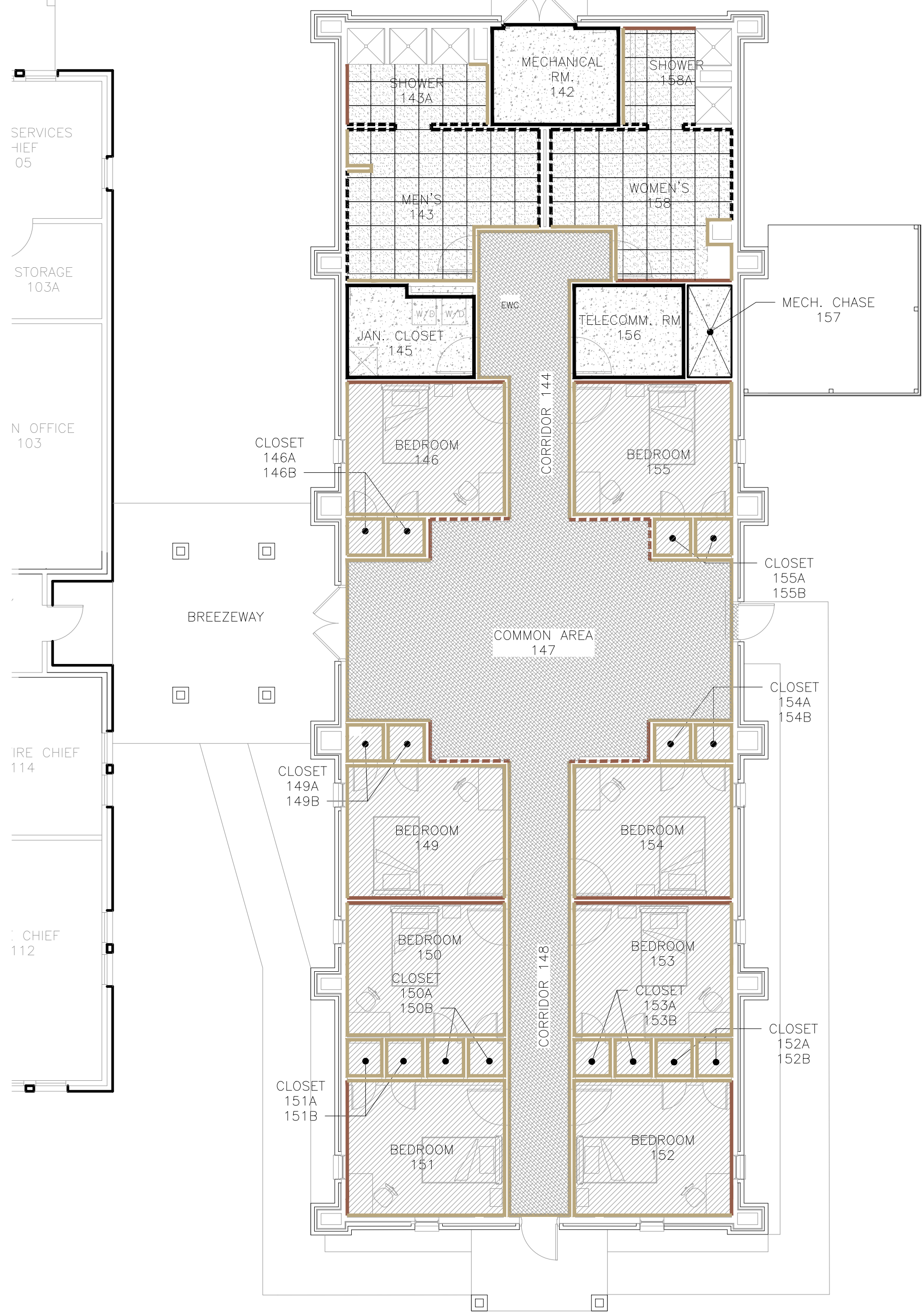

FINISH SCHEDULE (NEW ADDITION)

ROOM #	ROOM NAME	FLOOR	BASE	WALLS				CLG.	CLG. HT.	NOTES
				N	S	E	W			
142	MECHANICAL RM.	CN-1	RB-1	PT-3	PT-3	PT-3	PT-3	CL-2	10'-0"	
143	MEN'S RR	TL-1	TL-1	TL-2	PT-1	TL-2/PT-1	PT-2	CL-2	9'-0"	
143A	MEN'S SHOWER	TL-1	TL-1	-	TL-2	PT-2	PT-2	CL-2	9'-0"	
144	CORRIDOR	CP-1	RB-1	PT-1	PT-1	PT-1	PT-1	CL-1	9'-0"	
145	JAN. CLOSET	CN-1	RB-1	PT-3	PT-3	PT-3	PT-3	CL-2	9'-0"	
146	BEDROOM 1	CP-4	RB-1	PT-2	PT-1	PT-1	PT-1	CL-2	9'-0"	
146A	CLOSET	CP-4	RB-1	PT-1	PT-1	PT-1	PT-1	CL-2	9'-0"	
146B	CLOSET	CP-4	RB-1	PT-1	PT-1	PT-1	PT-1	CL-2	9'-0"	
147	COMMON AREA	CP-1	RB-1	PT-1/PT-2	PT-1/PT-2	PT-1/PT-2	PT-1/PT-2	CL-1	9'-0"	
148	CORRIDOR	CP-1	RB-1	-	PT-1	PT-1	PT-1	CL-1	9'-0"	
149	BEDROOM 3	CP-4	RB-1	PT-1	PT-2	PT-1	PT-1	CL-2	9'-0"	
149A	CLOSET	CP-4	RB-1	PT-1	PT-1	PT-1	PT-1	CL-2	9'-0"	
149B	CLOSET	CP-4	RB-1	PT-1	PT-1	PT-1	PT-1	CL-2	9'-0"	
150	BEDROOM 5	CP-4	RB-1	PT-2	PT-1	PT-1	PT-1	CL-2	9'-0"	
150A	CLOSET	CP-4	RB-1	PT-1	PT-1	PT-1	PT-1	CL-2	9'-0"	
150B	CLOSET	CP-4	RB-1	PT-1	PT-1	PT-1	PT-1	CL-2	9'-0"	
151	BEDROOM 7	CP-4	RB-1	PT-1	PT-1/PT-2	PT-1	PT-1/PT-2	CL-2	9'-0"	
151A	CLOSET	CP-4	RB-1	PT-1	PT-1	PT-1	PT-1	CL-2	9'-0"	
151B	CLOSET	CP-4	RB-1	PT-1	PT-1	PT-1	PT-1	CL-2	9'-0"	
152	BEDROOM 8	CP-4	RB-1	PT-1	PT-1/PT-2	PT-1	PT-2	CL-2	9'-0"	
152A	CLOSET	CP-4	RB-1	PT-1	PT-1	PT-1	PT-1	CL-2	9'-0"	
152B	CLOSET	CP-4	RB-1	PT-1	PT-1	PT-1	PT-1	CL-2	9'-0"	
153	BEDROOM 6	CP-4	RB-1	PT-2	PT-1	PT-1	PT-1	CL-2	9'-0"	
153A	CLOSET	CP-4	RB-1	PT-1	PT-1	PT-1	PT-1	CL-2	9'-0"	
153B	CLOSET	CP-4	RB-1	PT-1	PT-1	PT-1	PT-1	CL-2	9'-0"	
154	BEDROOM 4	CP-4	RB-1	PT-1	PT-2	PT-1	PT-1	CL-2	9'-0"	
154A	CLOSET	CP-4	RB-1	PT-1	PT-1	PT-1	PT-1	CL-2	9'-0"	
154B	CLOSET	CP-4	RB-1	PT-1	PT-1	PT-1	PT-1	CL-2	9'-0"	
155	BEDROOM 2	CP-4	RB-1	PT-2	PT-1	PT-1	PT-1	CL-2	9'-0"	
155A	CLOSET	CP-4	RB-1	PT-1	PT-1	PT-1	PT-1	CL-2	9'-0"	
155B	CLOSET	CP-4	RB-1	PT-1	PT-1	PT-1	PT-1	CL-2	9'-0"	
156	TELECOMM RM.	CN-1	RB-1	PT-3	PT-3	PT-3	PT-3	CL-1	9'-0"	
158	WOMAN'S RR	TL-1	TL-1	TL-2	PT-1/PT-2	TL-2/PT-1	TL-2/PT-1	CL-2	9'-0"	
158A	WOMEN'S SHOWER	TL-1	TL-1	TL-2	PT-1	-	-	CL-2	9'-0"	

FINISH SCHEDULE (BID OPTION - EXISTING FIRE STATION)

ROOM #	ROOM NAME	FLOOR	BASE	WALLS				CLG.	CLG. HT.	NOTES
				N	S	E	W			
129-1	BEDROOM	CP-4	RB-1	PT-1	PT-1	PT-1	PT-1	CL-2	9'-0"	
129-1A	CLOSET	CP-4	RB-1	PT-1	PT-1	PT-1	PT-1	CL-2	9'-0"	
129-1B	CLOSET	CP-4	RB-1	PT-1	PT-1	PT-1	PT-1	CL-2	9'-0"	
129-2	BEDROOM	CP-4	RB-1	PT-1	PT-1	PT-1	PT-1	CL-2	9'-0"	
129-2A	CLOSET	CP-4	RB-1	PT-1	PT-1	PT-1	PT-1	CL-2	9'-0"	
129-2B	CLOSET	CP-4	RB-1	PT-1	PT-1	PT-1	PT-1	CL-2	9'-0"	
131-1	BEDROOM	CP-4	RB-1	PT-1	PT-1	PT-1	PT-1	CL-2	9'-0"	
131-1A	CLOSET	CP-4	RB-1	PT-1	PT-1	PT-1	PT-1	CL-2	9'-0"	
131-1B	CLOSET	CP-4	RB-1	PT-1	PT-1	PT-1	PT-1	CL-2	9'-0"	
131-2	BEDROOM	CP-4	RB-1	PT-1	PT-1	PT-1	PT-1	CL-2	9'-0"	
131-2A	CLOSET	CP-4	RB-1	PT-1	PT-1	PT-1	PT-1	CL-2	9'-0"	
131-2B	CLOSET	CP-4	RB-1	PT-1	PT-1	PT-1	PT-1	CL-2	9'-0"	
133	BEDROOM	CP-4	RB-1	PT-1	PT-1	PT-1	PT-1	CL-2	9'-0"	
133A	CLOSET	CP-4	RB-1	PT-1	PT-1	PT-1	PT-1	CL-2	9'-0"	
133B	CLOSET	CP-4	RB-1	PT-1	PT-1	PT-1	PT-1	CL-2	9'-0"	
134	BEDROOM	CP-4	RB-1	PT-1	PT-1	PT-1	PT-1	CL-2	9'-0"	
134A	CLOSET	CP-4	RB-1	PT-1	PT-1	PT-1	PT-1	CL-2	9'-0"	
134B	CLOSET	CP-4	RB-1	PT-1	PT-1	PT-1	PT-1	CL-2	9'-0"	

DOOR SCHEDULE (NEW ADDITION)

DOOR #	ROOM NAME	TYPE	DOOR			FINISH	HARDWARE	FRAME		NOTES	
			WIDTH	HEIGHT	THICKNESS			TYPE	FINISH		
142	MECHANICAL RM.	D	6'-0"	7'-0"	1-3/4"	H.M.	PTD.	1	B	PTD.	SW#7675 "SEALSKIN"
143	MEN'S RR	C	3'-0"	7'-0"	1-3/4"	WOOD	STAIN	4	A	PTD.	
145	JANITOR'S CLOSET	C	3'-0"	7'-0"	1-3/4"	WOOD	STAIN	5	A	PTD.	
146	BEDROOM 1	A	3'-0"	7'-0"	1-3/4"	WOOD	STAIN	6	A	PTD.	
146A	CLOSET	B	2'-0"	7'-0"	1-3/4"	WOOD	STAIN	7	E	PTD.	
146B	CLOSET	B	2'-0"	7'-0"	1-3/4"	WOOD	STAIN	7	E	PTD.	
147A	COMMON AREA	E	6'-0"	7'-0"	1-3/4"	ALUM.	TRANSPARENT	2	C	ALUM.	
147B	COMMON AREA	F	3'-0"	7'-0"	1-3/4"	ALUM.	TRANSPARENT	3	D	ALUM.	
148	CORRIDOR	F	3'-0"	7'-0"	1-3/4"	ALUM.	TRANSPARENT	3	D	ALUM.	
149	BEDROOM 3	A	3'-0"	7'-0"	1-3/4"	WOOD	STAIN	6	A	PTD.	
149A	CLOSET	B	2'-0"	7'-0"	1-3/4"	WOOD	STAIN	7	E	PTD.	
149B	CLOSET	B	2'-0"	7'-0"	1-3/4"	WOOD	STAIN	7	E	PTD.	
150	BEDROOM 5	A	3'-0"	7'-0"	1-3/4"	WOOD	STAIN	6	A	PTD.	
150A	CLOSET	B	2'-0"	7'-0"	1-3/4"	WOOD	STAIN	7	E	PTD.	
150B	CLOSET	B	2'-0"	7'-0"	1-3/4"	WOOD	STAIN	7	E	PTD.	
151	BEDROOM 7	A	3'-0"	7'-0"	1-3/4"	WOOD	STAIN	6	A	PTD.	
151A	CLOSET	B	2'-0"	7'-0"	1-3/4"	WOOD	STAIN	7	E	PTD.	
151B	CLOSET	B	2'-0"	7'-0"	1-3/4"	WOOD	STAIN	7	E	PTD.	
152	BEDROOM 8	A	3'-0"	7'-0"	1-3/4"	WOOD	STAIN	6	A	PTD.	
152A	CLOSET	B	2'-0"	7'-0"	1-3/4"	WOOD	STAIN	7	E	PTD.	
152B	CLOSET	B	2'-0"	7'-0"	1-3/4"	WOOD	STAIN	7	E	PTD.	
153	BEDROOM 6	A	3'-0"	7'-0"	1-3/4"	WOOD	STAIN	6	A	PTD.	
153A	CLOSET	B	2'-0"	7'-0"	1-3/4"	WOOD	STAIN	7	E	PTD.	
153B	CLOSET	B	2'-0"	7'-0"	1-3/4"	WOOD	STAIN	7	E	PTD.	
154	BEDROOM 4	A	3'-0"	7'-0"	1-3/4"	WOOD	STAIN	6	A	PTD.	
154A	CLOSET	B	2'-0"	7'-0"	1-3/4"	WOOD	STAIN	7	E	PTD.	
154B	CLOSET	B	2'-0"	7'-0"	1-3/4"	WOOD	STAIN	7	E	PTD.	
155	BEDROOM 2	A	3'-0"	7'-0"	1-3/4"	WOOD	STAIN	6	A	PTD.	
155A	CLOSET	B	2'-0"	7'-0"	1-3/4"	WOOD	STAIN	7	E	PTD.	
155B	CLOSET	B	2'-0"	7'-0"	1-3/4"	WOOD	STAIN	7	E	PTD.	
156	TELECOMM RM.	C	3'-0"	7'-0"	1-3/4"	WOOD	STAIN	5	A	PTD.	
158	WOMAN'S RR	C	3'-0"	7'-0"	1-3/4"	WOOD	STAIN	4	A	PTD.	

DOOR SCHEDULE (BID OPTIONS - EXISTING FIRE STATION)

DOOR #	ROOM NAME	TYPE	DOOR			FINISH	HARDWARE	FRAME		NOTES
			WIDTH	HEIGHT	THICKNESS			TYPE	FINISH	
129-1	BEDROOM	C	3'-0"	7'-0"	1-3/4"	WOOD	STAIN	6	A	PTD.
129-1A	CLOSET	B	2'-0"	7'-0"	1-3/4"	WOOD	STAIN	7	E	PTD.
129-1B	CLOSET	B	2'-0"	7'-0"	1-3/4"	WOOD	STAIN	7	E	PTD.
129-2	BEDROOM	C	3'-0"	7'-0"	1-3/4"	WOOD	STAIN	6	A	PTD.
129-2A	CLOSET	B	2'-0"	7'-0"	1-3/4"	WOOD	STAIN	7	E	PTD.
129-2B	CLOSET	B	2'-0"	7'-0"	1-3/4"	WOOD	STAIN	7	E	PTD.
130	MEN'S RR	C	3'-0"	7'-0"	1-3/4"	WOOD	STAIN			PTD.
131-1	BEDROOM	C	3'-0"	7'-0"	1-3/4"	WOOD	STAIN	6	A	PTD.
131-1A	CLOSET	B	2'-0"	7'-0"	1-3/4"	WOOD	STAIN	7	E	PTD.
131-1B	CLOSET	B	2'-0"	7'-0"	1-3/4"	WOOD	STAIN	7	E	PTD.
131-2	BEDROOM	C	3'-0"	7'-0"	1-3/4"	WOOD	STAIN	6	A	PTD.
131-2A	CLOSET	B	2'-0"	7'-0"	1-3/4"	WOOD	STAIN	7	E	PTD.
131-2B	CLOSET	B	2'-0"	7'-0"	1-3/4"	WOOD	STAIN	7	E	PTD.
133-1	BEDROOM	C	3'-0"	7'-0"	1-3/4"	WOOD	STAIN	6	A	PTD.
133-1A	CLOSET	B	2'-0"	7'-0"	1-3/4"	WOOD	STAIN	7	E	PTD.
133-1B	CLOSET	B	2'-0"	7'-0"	1-3/4"	WOOD	STAIN	7	E	PTD.
133-2	BEDROOM	C	3'-0"	7'-0"	1-3/4"	WOOD	STAIN	6	A	PTD.
133-2A	CLOSET	B	2'-0"	7'-0"	1-3/4"	WOOD	STAIN	7	E	PTD.
133-2B	CLOSET	B	2'-0"	7'-0"	1-3/4"	WOOD	STAIN	7	E	PTD.
134	MEN'S RR	C	3'-0"	7'-0"	1-3/4"	WOOD	STAIN			PTD.

- DOOR SCHEDULE NOTES:
- 18 GA. GALV. HOLLOW MTL. DOORS & ALL DOOR FRAMES SHALL BE 16 GA. GALV. HOLLOW MTL FRAMES EQ. TO REPUBLIC BRAND DOORS AND FRAMES PER SDI-100.
 - WOOD DOORS SHALL BE EQUAL TO MASONITE ARCHITECTURAL BRAND. REFERENCE NOTE #3 BELOW.
 - INTERIOR DOORS SHALL BE STAIN GRAIN SOLID CORE WOOD DOORS AS SCHEDULED. SOLID CORE WOOD DOORS SHALL BE 5-PLY W/ 1-3/8" HARDWOOD STILES, MIN., 1-1/8" SOLID WOOD RAILS, MIN., 5" WIDE SOLID BLOCKING FOR HARDWARE AND STAVE CORES. ROTARY CUT BIRCH VENEER THROUGHOUT WITH UNIFORM COLOR AND GRAIN WITH NO SPLICHTS LARGE OR SMALL.
 - WHERE FLOORING MATERIAL CHANGES BETWEEN ROOMS, THE CHANGES SHALL OCCUR AT THE CENTERLINE OF THE DOOR PANEL.
 - PROVIDE COMPLETE HARDWARE SCHEDULE OF ITEMS FOR REVIEW & APPROVAL PRIOR TO INSTALLATION.
 - PROVIDE COMPLETE HARDWARE AND ACCESSORIES FOR ALL DOORS LISTED HEREON, PROVIDE A.D.A. COMPLIANT DOOR HANDLES THROUGHOUT ONLY. RE: CURRENT A.D.A. REQUIREMENTS FOR ALL HARDWARE CRITERIA.
 - INCLUDE HARDWARE FOR ELECTRIC PANELS AS REQUIRED.

2 FINISH FLOOR PLAN-NEW ADDITION
 $\frac{1}{8}'' = 1' - 0''$

- ### LEGEND
- TL-1: 24"x24" FLOOR TILE
 - TL-2: 12x24" WALL TILE
 - PT-1: FIELD PAINT SW#9856
 - PT-2: ACCENT PAINT SW#9595
 - PT-4: PAINT SW#7007
 - CP-1: CARPET TILE
 - CP-2: NOT USED
 - CP-3: NOT USED
 - CP-4: BROADLOOM CARPET
 - LVP-1: LVP ACCENT WALL
 - CN-1: POLISHED CONCRETE

FINISH LEGEND OR APPROVED EQ.

NAME	DESCRIPTION	MFR	MODEL/STYLE	COLOR/FINISH	REMARKS
FLOORING					
CN-1	POLISHED CONCRETE				

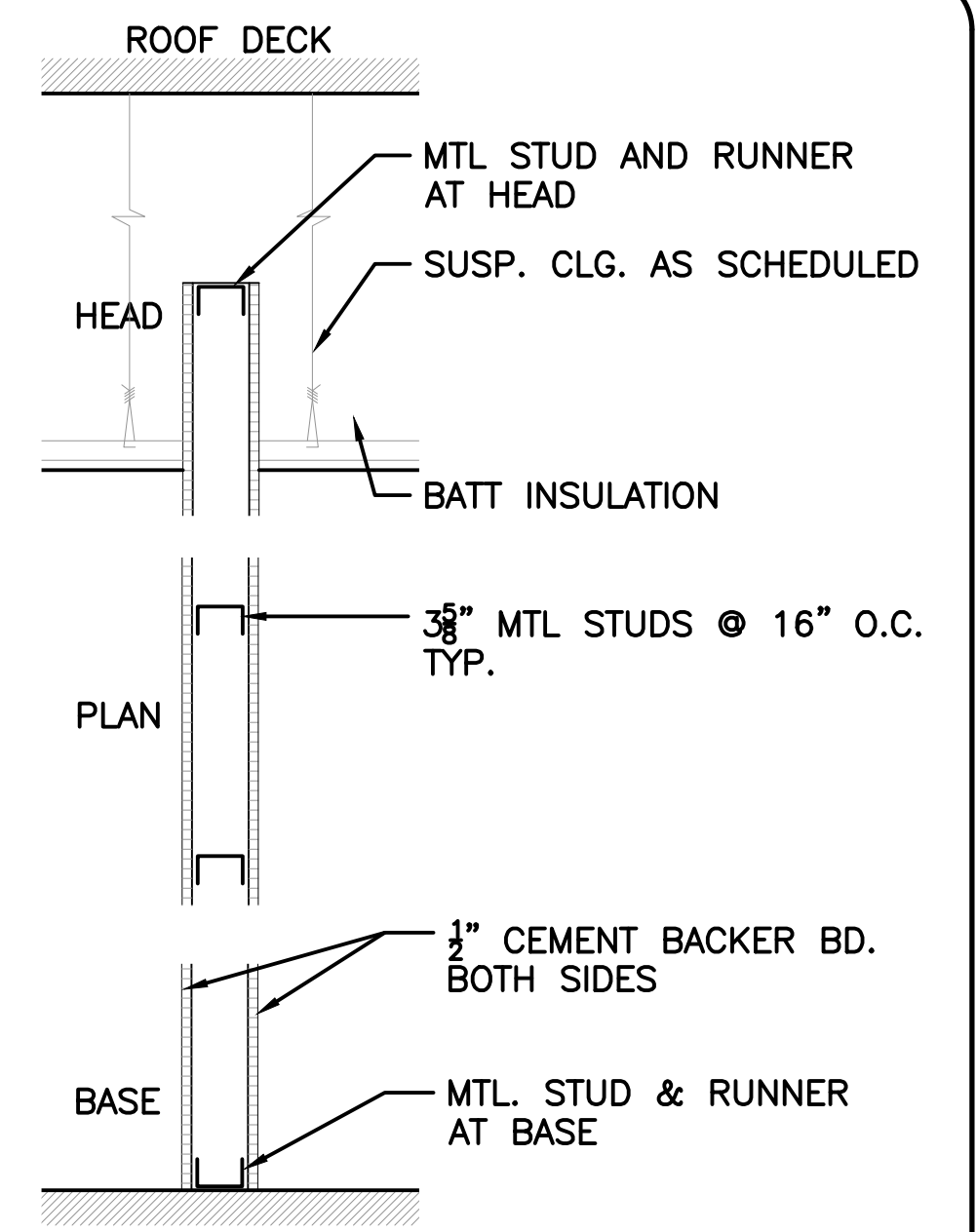
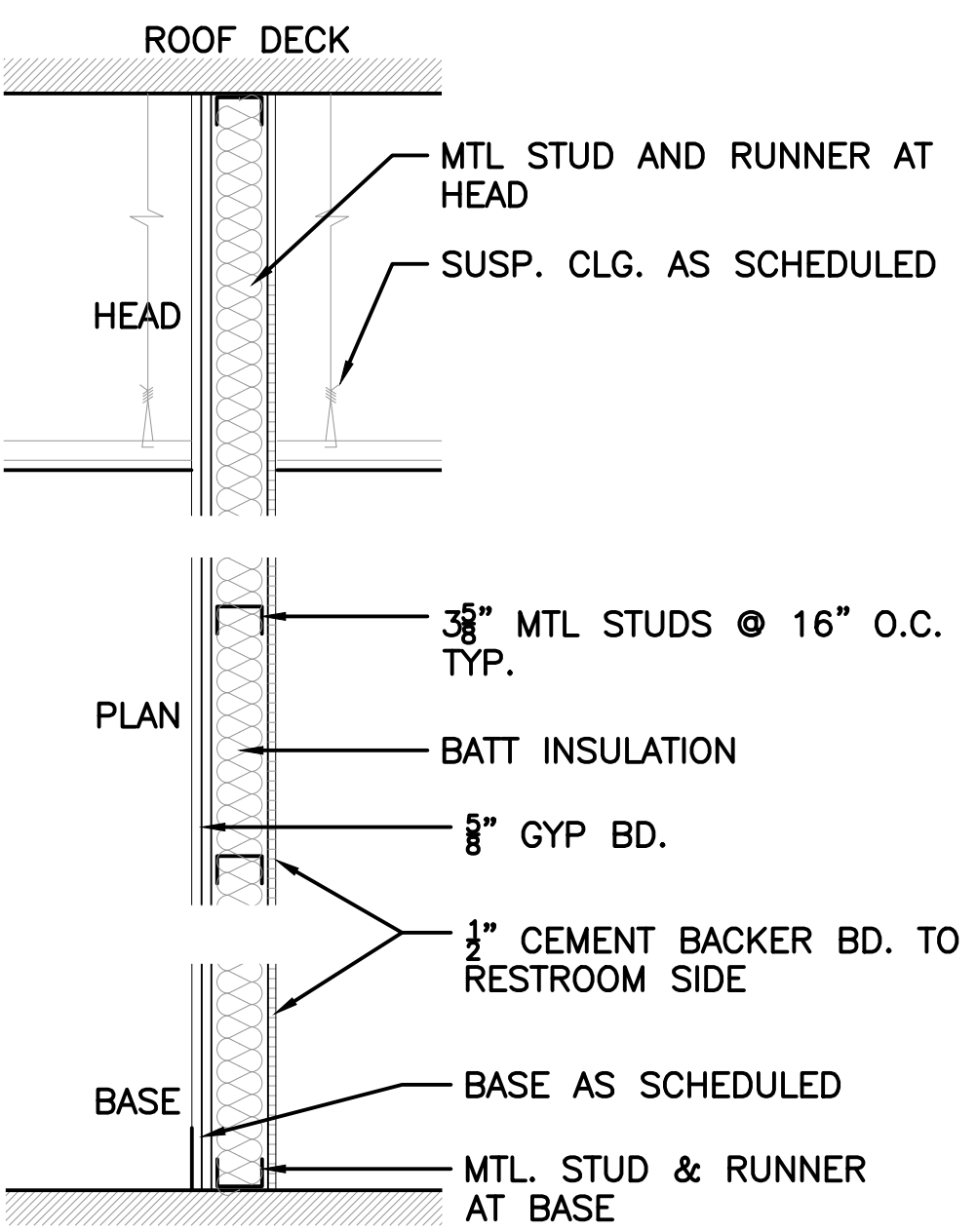
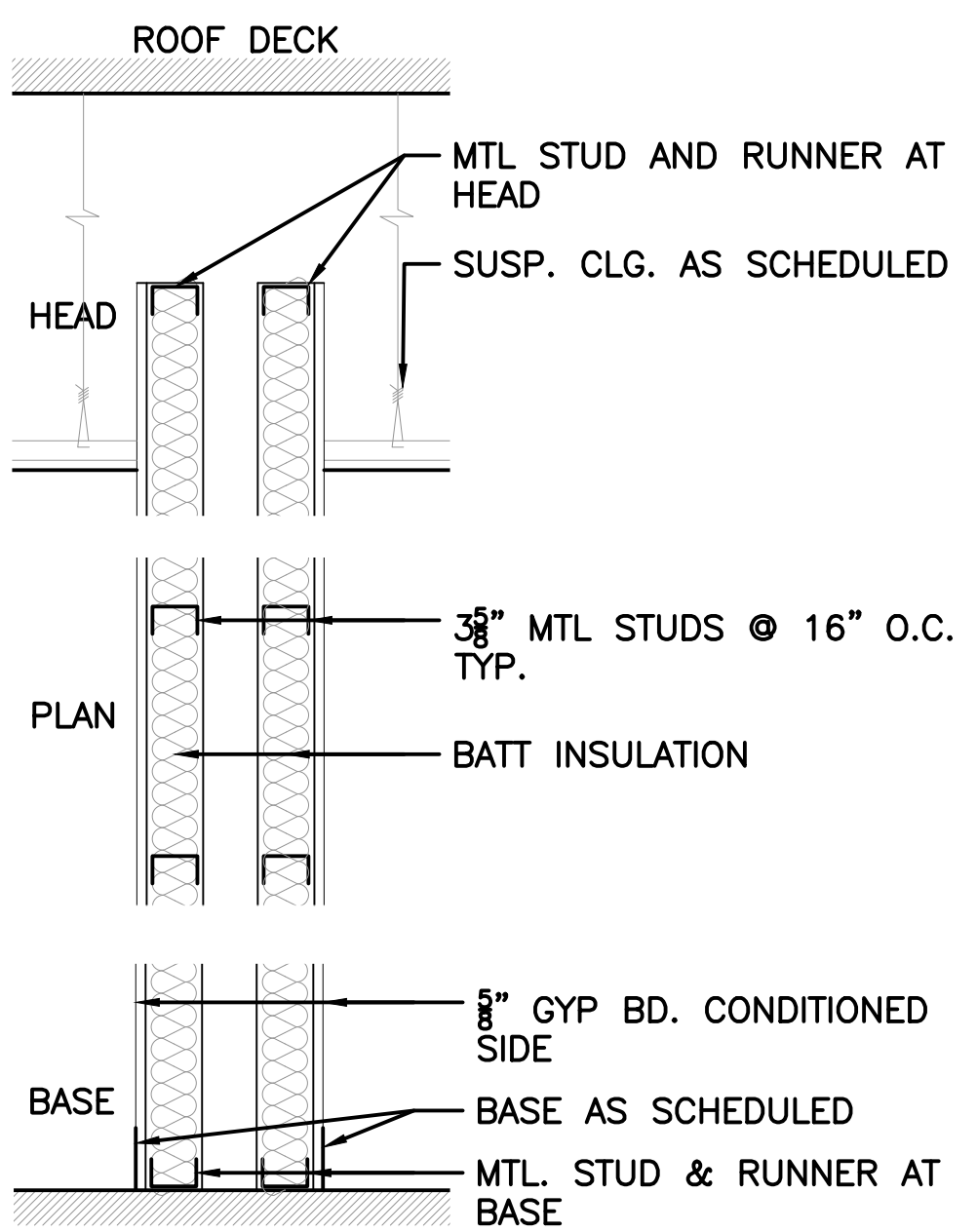
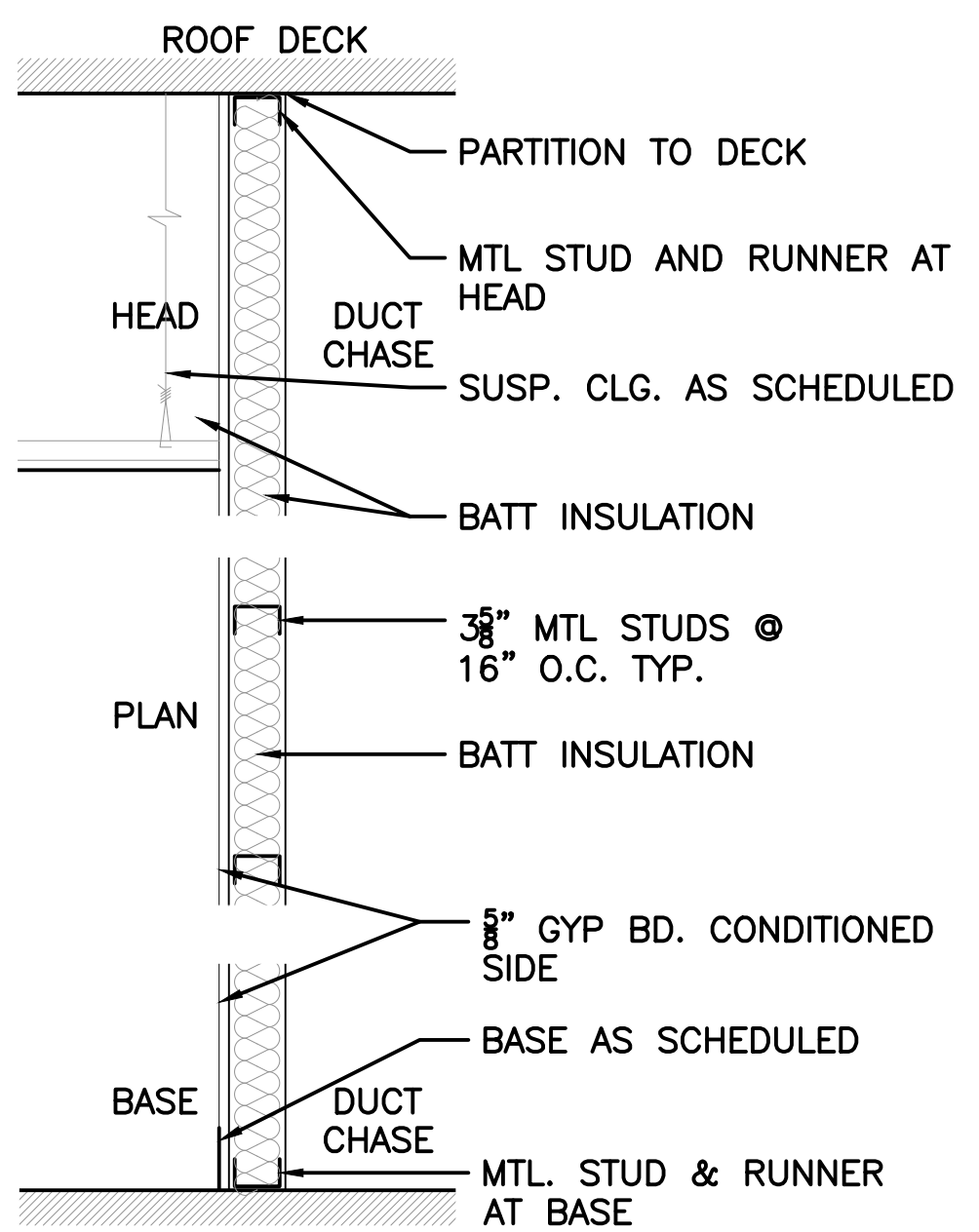
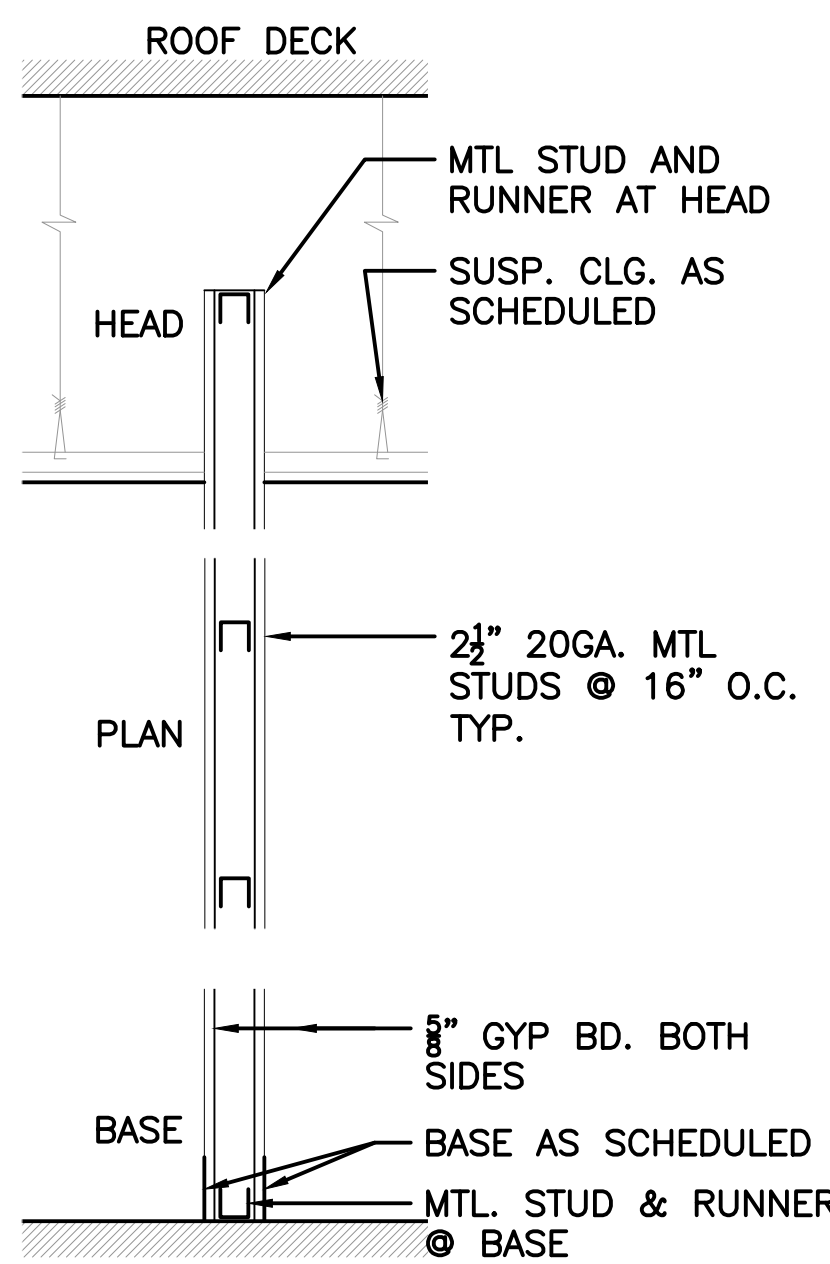
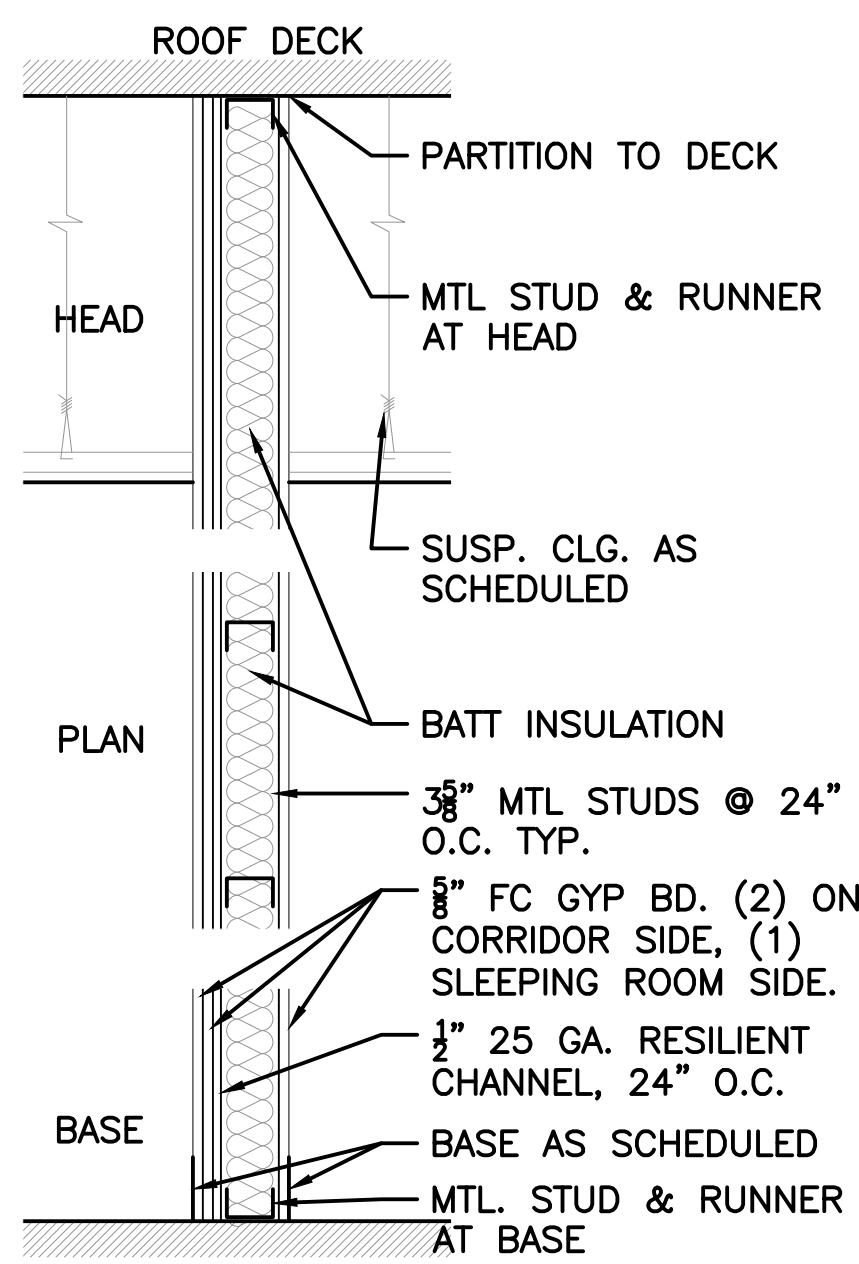

NOTE: 1A - BID OPTION
PARTITIONS TO MATCH HEIGHT OF EXISTING PARTITIONS.

NOTE: SLEEPING AREA / CORRIDORS
1HR RATED WALL ASSEMBLY SEALED TO DECK. FIRESTOP ALL PENETRATIONS.

NOTE: CLOSET PARTITIONS

NOTE: TELECOMM / MECH. CHASE
1HR RATED WALL ASSEMBLY. SEAL TO DECK. FIRESTOP ALL PENETRATIONS.

NOTE: RESTROOM CHASE
1HR RATED WALL ASSEMBLY. SEAL TO DECK. FIRESTOP ALL PENETRATIONS.

NOTE: MECHANICAL ROOM PARTITION
1HR RATED WALL ASSEMBLY. SEAL TO DECK. FIRESTOP ALL PENETRATIONS.

NOTE: RESTROOM PARTITIONS
6A: PARTITIONS ONLY RECEIVE BACKER BD. AND TILE FINISH ON RESTROOM SIDE.

1 PARTITION TYPES
1" = 1' - 0"

NOTE: REFER TO A/401 FOR PARTITION HEAD SUPPORT DTLS. AND SUSP. CLG. SUPPORT DTLS.

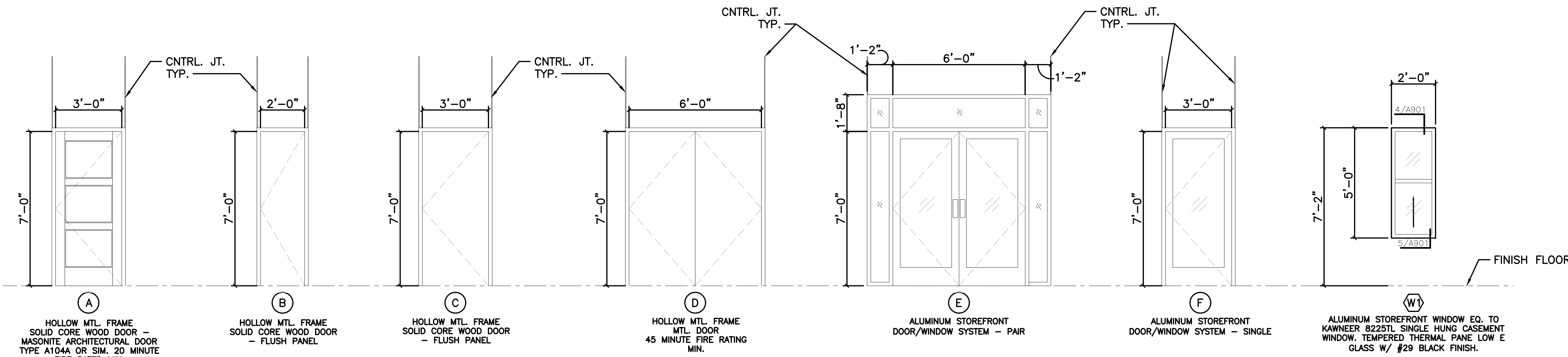

2 DOOR TYPES
3/8" = 1' - 0"

3 WINDOW TYPES
3/8" = 1' - 0"

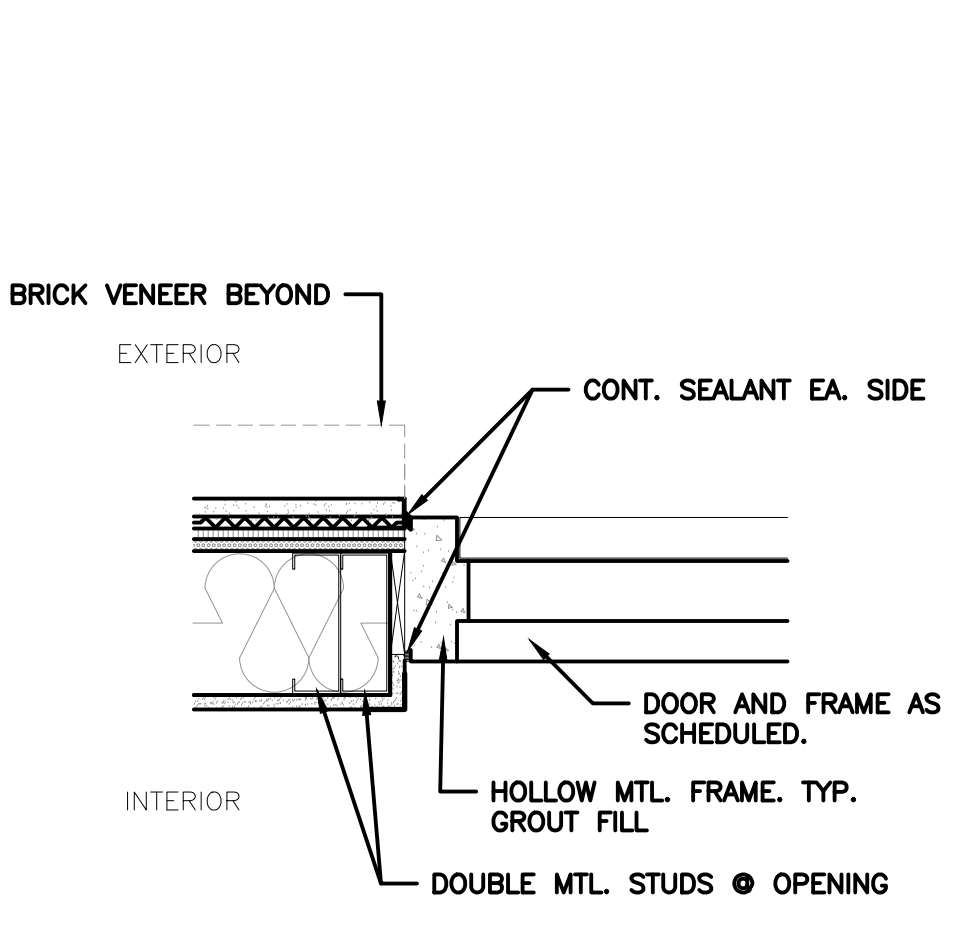
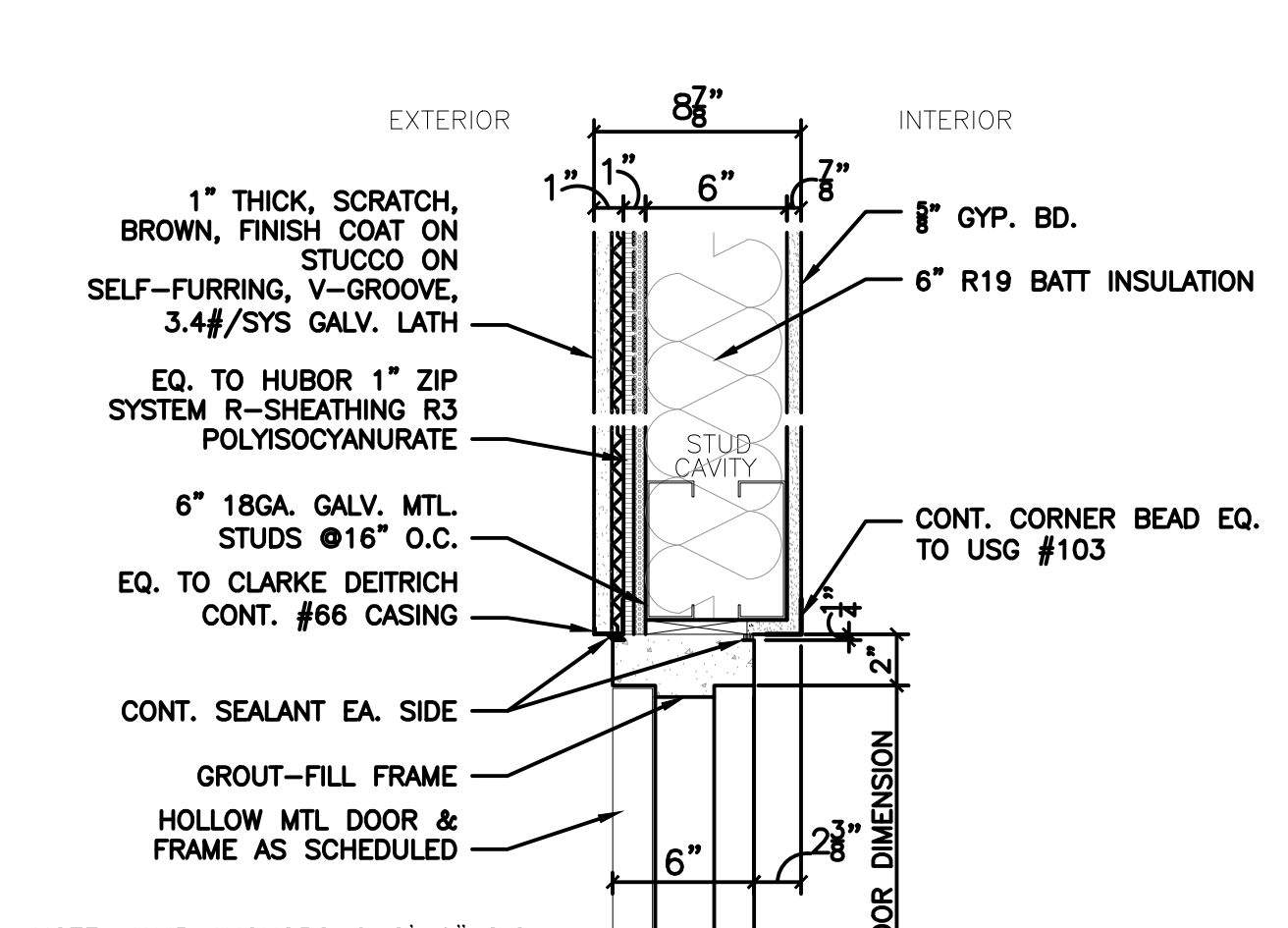
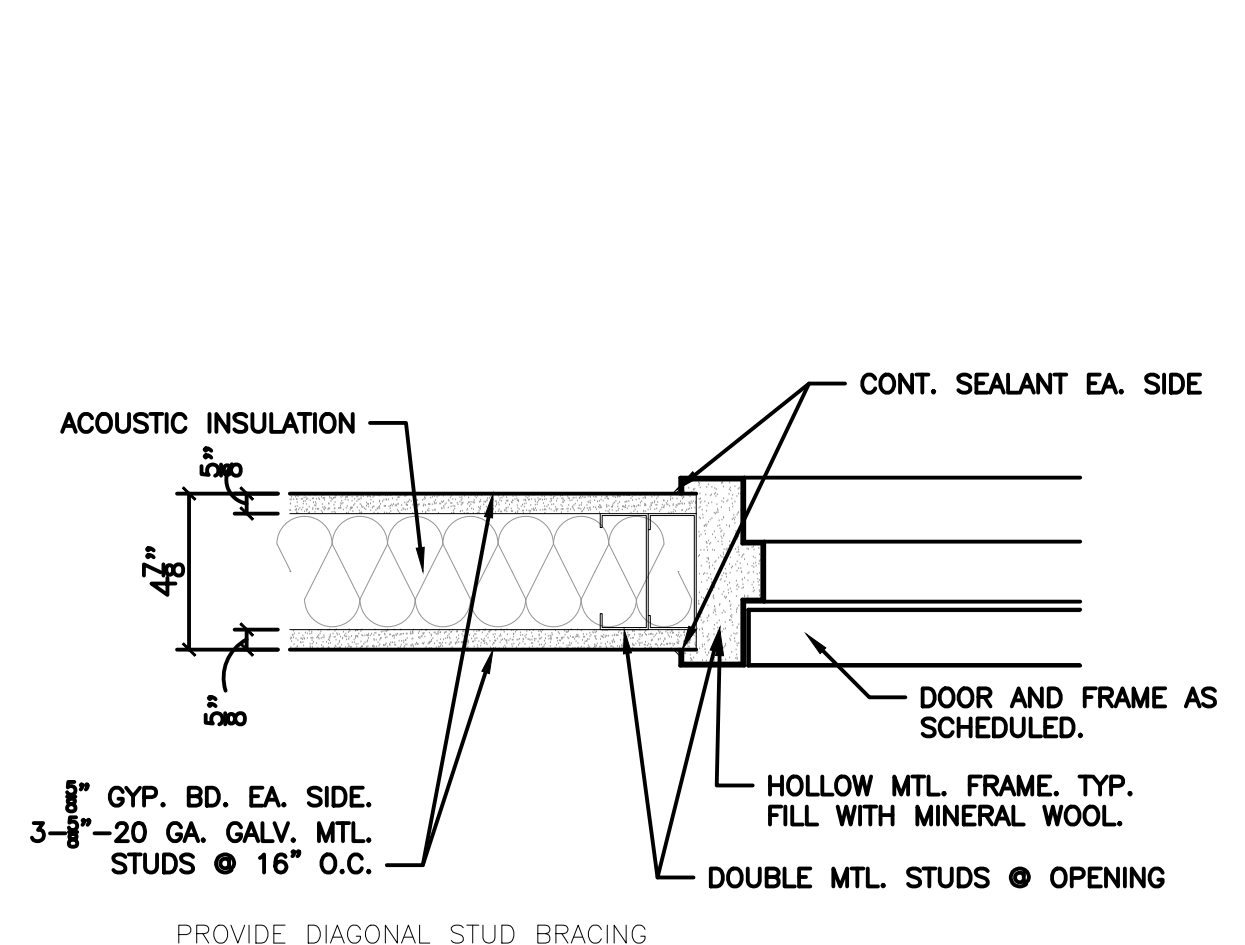
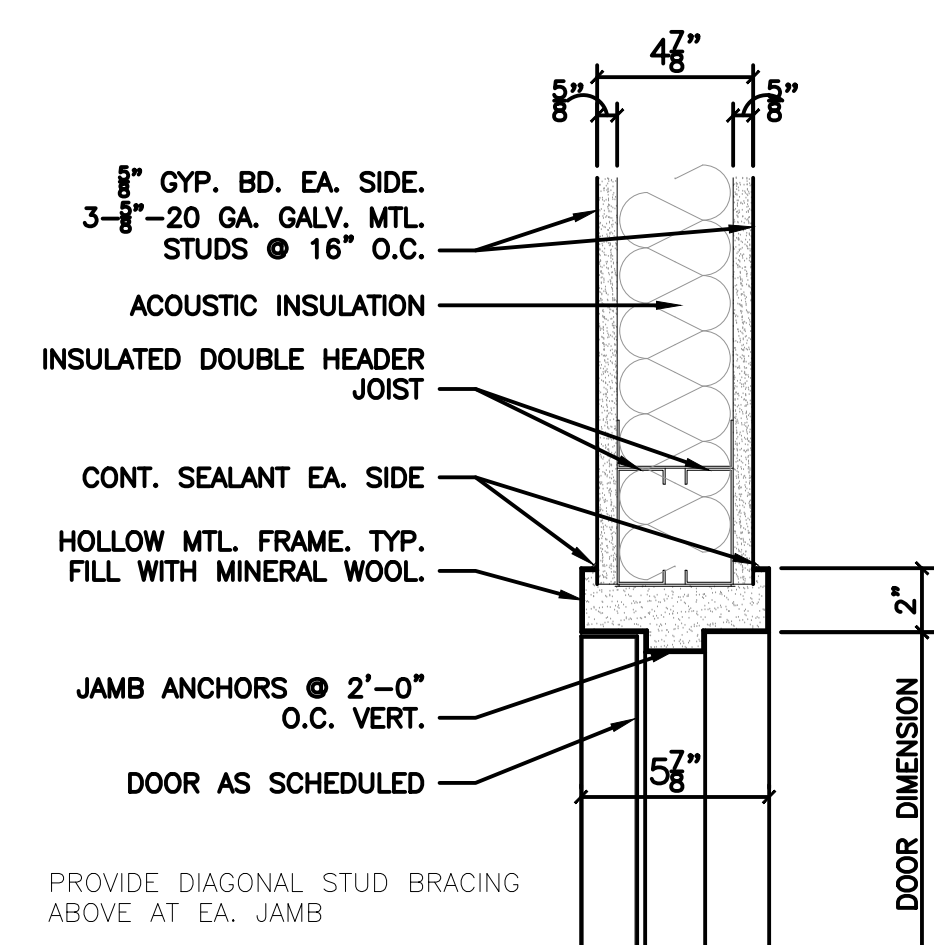
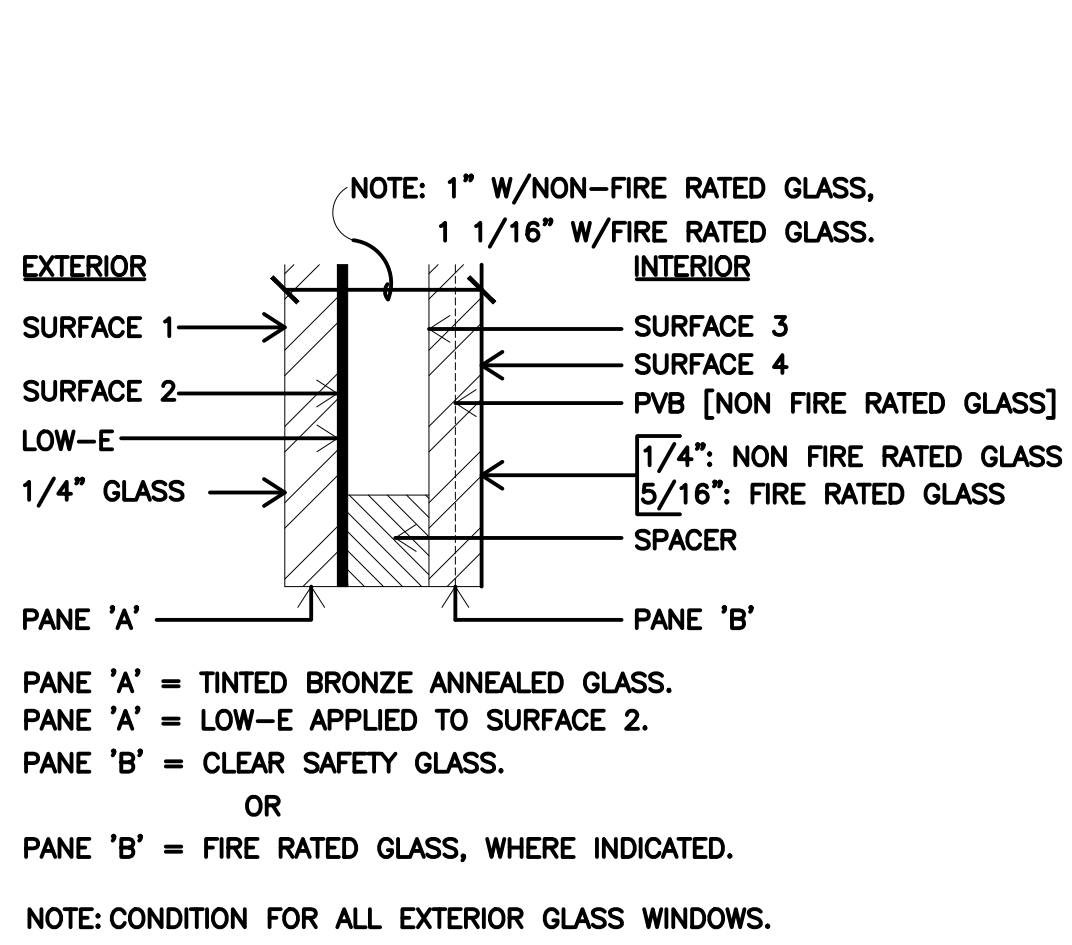

4 LOW "E" GLASS
NTS

5 INT. DOOR HEAD
SCALE: 1 1/2" = 1'-0"

6 INT. DOOR JAMB
SCALE: 1 1/2" = 1'-0"

7 EXT. DOOR HEAD
JAMB SIM.
SCALE: 1 1/2" = 1'-0"

8 EXT. DOOR JAMB
SCALE: 1 1/2" = 1'-0"

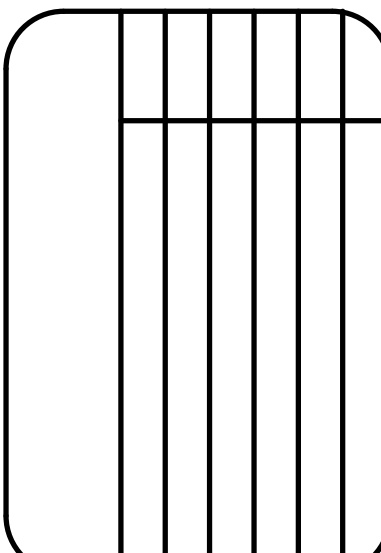
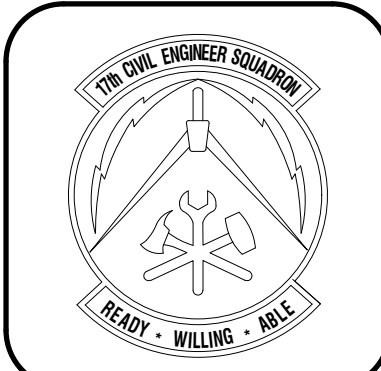

Designed by: J.H.R.M.L.A.
Drawn by: J.H.R.M.L.A.
Reviewed by: RTI/J.H.
Submitted by: P.C.B.S.

PROJECT TITLE
FIRE STATION ADD/ALTER, B3321
PROJECT NO. 1039839
17th TRAINING WING
GOODFELLOW AIR FORCE BASE, TEXAS

Project Number: 1039839
SHEET TITLE: DOORS, WINDOWS, AND PARTITION TYPES
Date: SEP 2023

SEQ. SHEET OF
28 A-802 50

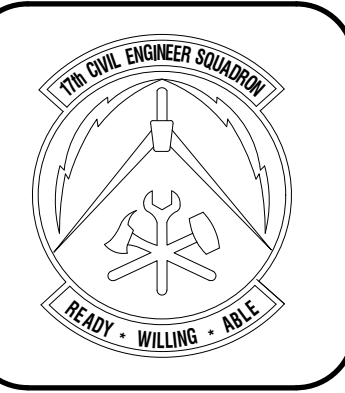

24 GA. STANDING SEAM MTL. ROOF PANELS TO MATCH EXIST. PROVIDE THERMAL BLOCKS @ EA. PURLING.
 7/8"-18 GA. GALV. MTL. FURRING CHANNELS @ 4'-0" O.C. MAX. 1 1/2" TYPE B-20, GALV. MTL. DECK.
 8" R-30 FSK BATT INSULATION W/1" WIDE X 20 GA. STL. BANDING
 12 GA. GALV. TIE-WIRE @ 48" O.C.E.W W/ ONE EA. TIRE WIRE @ EA. CORNER OF LIGHT & MEP FIXTURES
 R-19 BATT INSULATION
 2'X2' SUSP. GRID CLG. SYS. GYP. BD.
 BOARD AND BLOCK COMPOSITE AS SPECIFIED
 DOUBLE STUD HEADER
 1" THICK, SCRATCH, BROWN, FINISH COAT ON STUCCO ON SELF-FURRING, V-GROOVE, 3.4#/SYS GALV. LATH
 DOOR AS SCHEDULED
 BRICK VENEER & WAINSCOT BEYOND
 BASE AS SCHEDULED BEYOND
 FIN. FLR. =185=62.00'
 CONC. FOUNDATION, RE: STRUCT
 6" CAPILLARY BARRIER
 6 MIL VAPOR BARRIER
 COMPACTED FILL TO 95% PROCTOR DENSITY

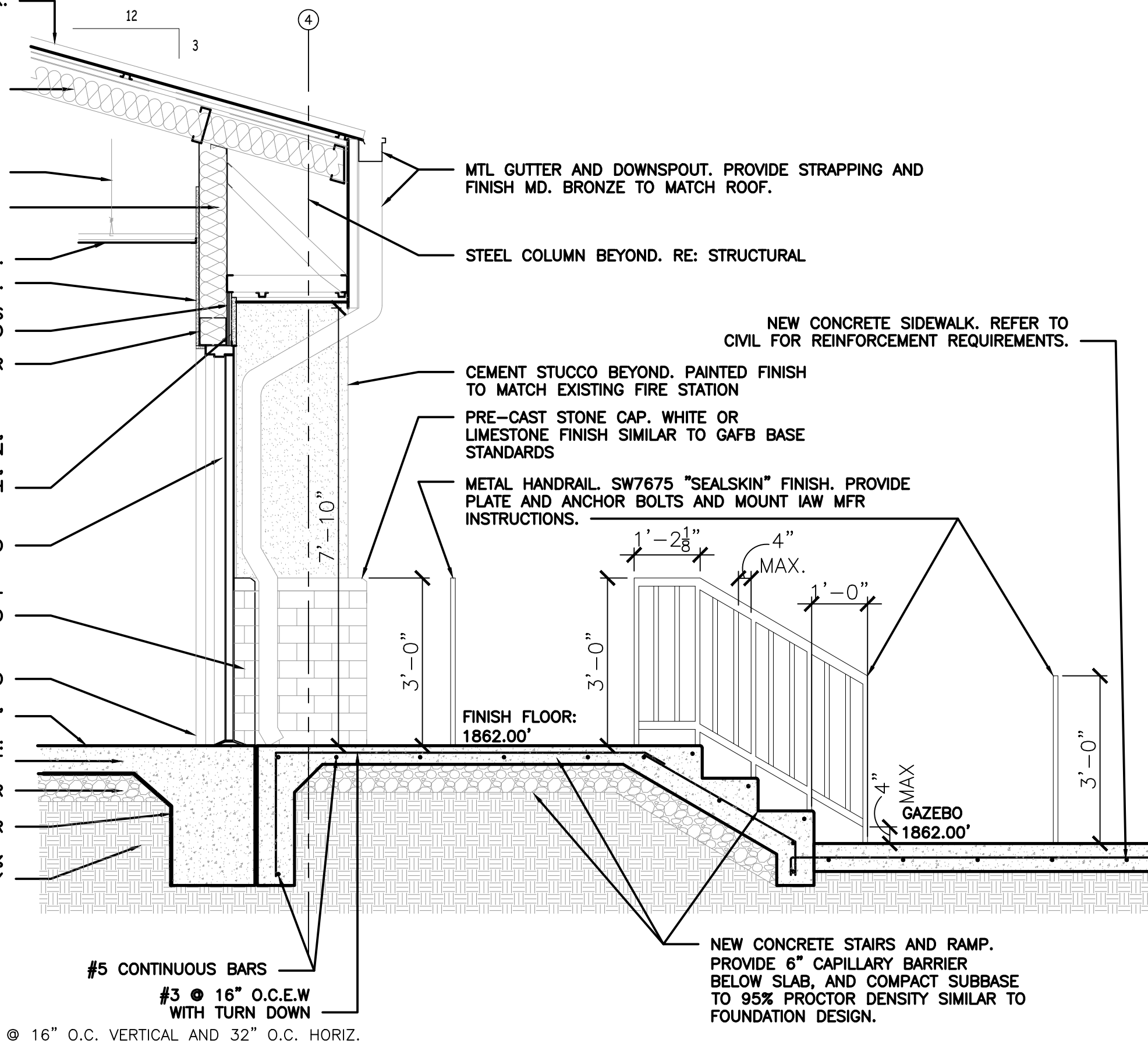

1 WALL SECTION-THRU DOOR
 1/2" = 1' - 0"

24 GA. STANDING SEAM MTL. ROOF PANELS TO MATCH EXIST. PROVIDE THERMAL BLOCKS @ EA. PURLING.
 7/8"-18 GA. GALV. MTL. FURRING CHANNELS @ 4'-0" O.C. MAX. 1 1/2" TYPE B-20, GALV. MTL. DECK.
 8" R-30 FSK BATT INSULATION W/1" WIDE X 20 GA. STL. BANDING
 12 GA. GALV. TIE-WIRE @ 48" O.C.E.W W/ ONE EA. TIRE WIRE @ EA. CORNER OF LIGHT & MEP FIXTURES
 R-19 BATT INSULATION
 2'X2' SUSP. GRID CLG. SYS. GYP. BD.
 BOARD AND BLOCK SHEATHING AS SPECIFIED
 6" 18GA. GALV. MTL. STUDS @ 16" O.C., MAX.
 1" THICK, SCRATCH, BROWN, FINISH COAT ON STUCCO ON SELF-FURRING, V-GROOVE, 3.4#/SYS GALV. LATH
 WINDOW AS SCHEDULED
 BRICK VENEER & WAINSCOT BEYOND
 CONT. THRU WALL FLASHING. TYP.
 BASE AS SCHEDULED
 FIN. FLR. =1862.00'
 6" CAPILLARY BARRIER
 6 MIL VAPOR BARRIER
 COMPACTED FILL TO 95% PROCTOR DENSITY

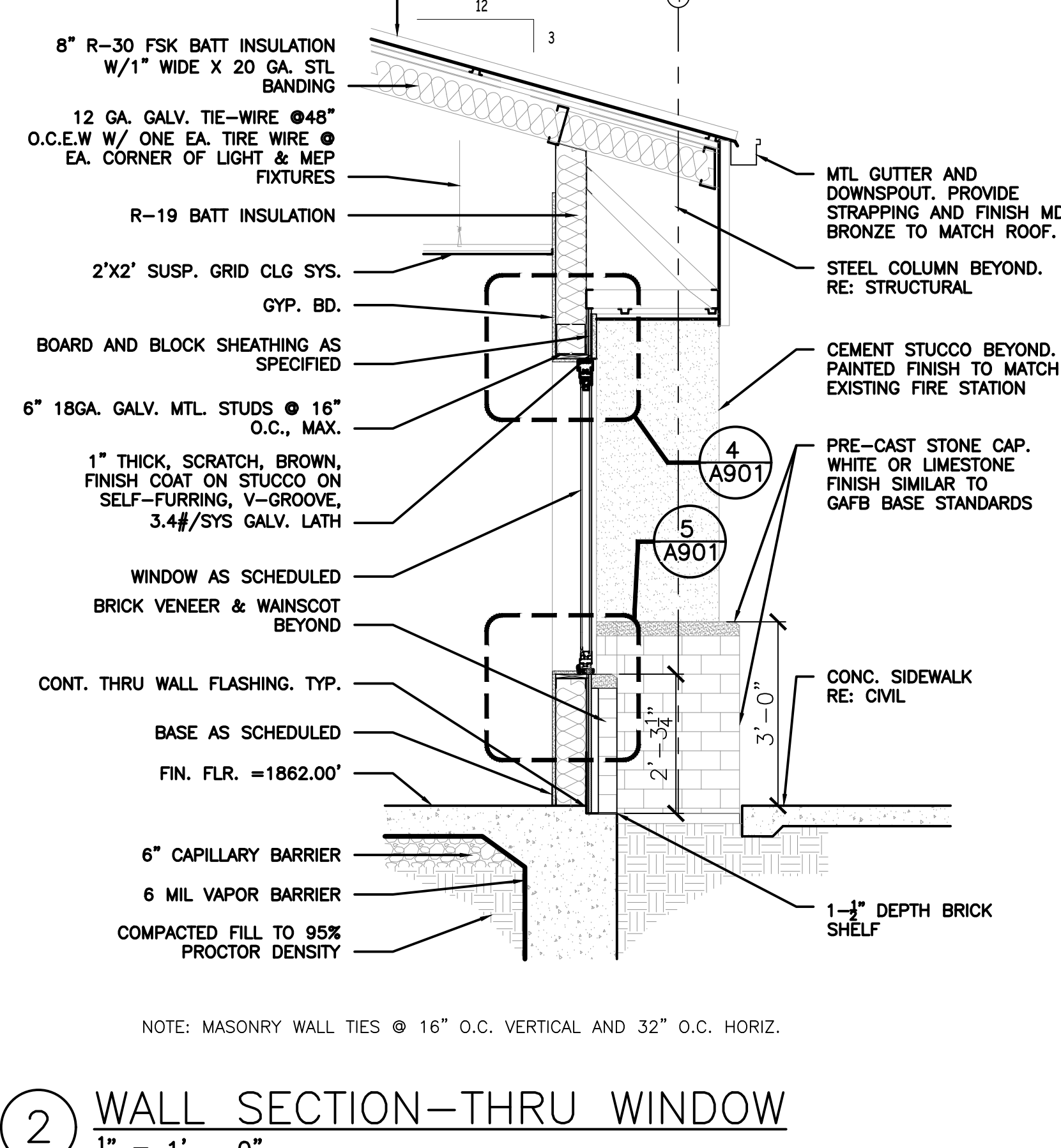

2 WALL SECTION-THRU WINDOW
 1/2" = 1' - 0"

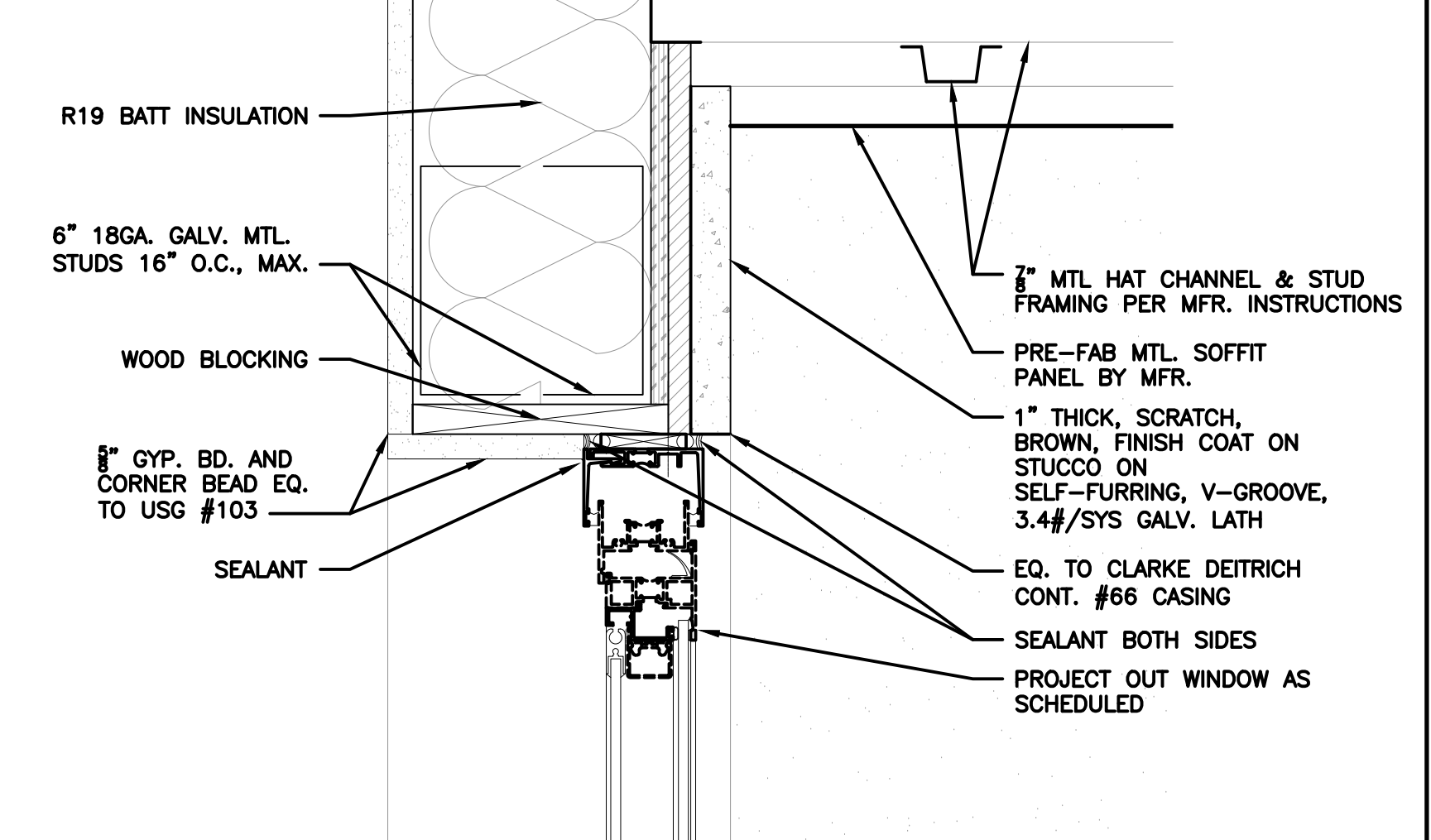

4 WINDOW HEAD DTL.
 3" = 1' - 0"

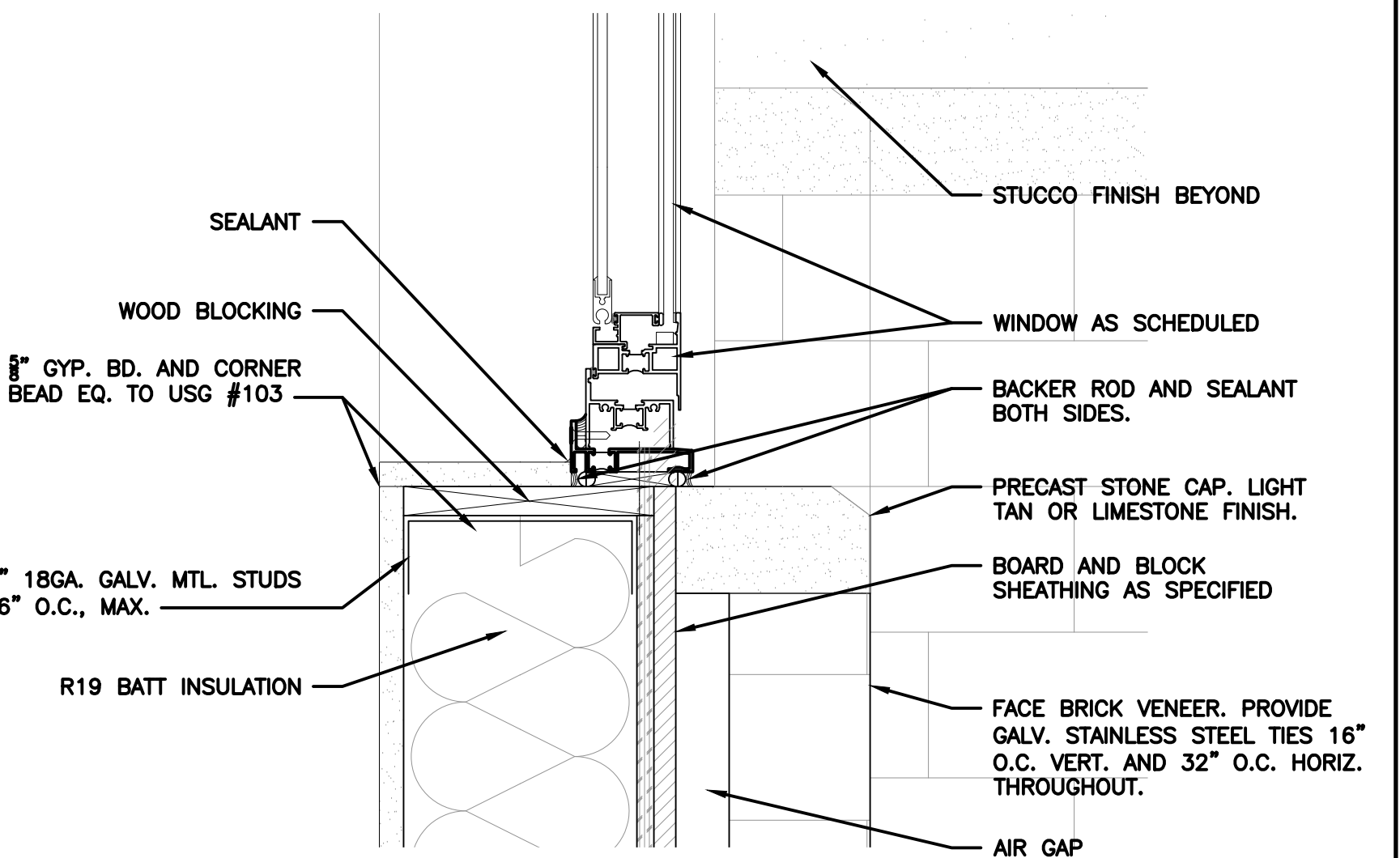

5 WINDOW SILL DTL.
 3" = 1' - 0"

24 GA. STANDING SEAM MTL. ROOF PANELS TO MATCH EXIST. PROVIDE THERMAL BLOCKS @ EA. PURLING.
 7/8"-18 GA. GALV. MTL. FURRING CHANNELS @ 4'-0" O.C. MAX. 1 1/2" TYPE B-20, GALV. MTL. DECK.
 8" R-30 FSK BATT INSULATION W/1" WIDE X 20 GA. STL. BANDING
 12 GA. GALV. TIE-WIRE @ 48" O.C.E.W W/ ONE EA. TIRE WIRE @ EA. CORNER OF LIGHT & MEP FIXTURES
 R-19 BATT INSULATION
 2'X2' SUSP. GRID CLG. SYS.
 BOARD AND BLOCK SHEATHING AS SPECIFIED
 6" 18GA. GALV. MTL. STUDS @ 16" O.C., MAX.
 1" THICK, SCRATCH, BROWN, FINISH COAT ON STUCCO ON SELF-FURRING, V-GROOVE, 3.4#/SYS GALV. LATH
 BRICK VENEER & WAINSCOT BEYOND
 CONT. THRU WALL FLASHING. TYP.
 BASE AS SCHEDULED
 FIN. FLR. =1862.00'

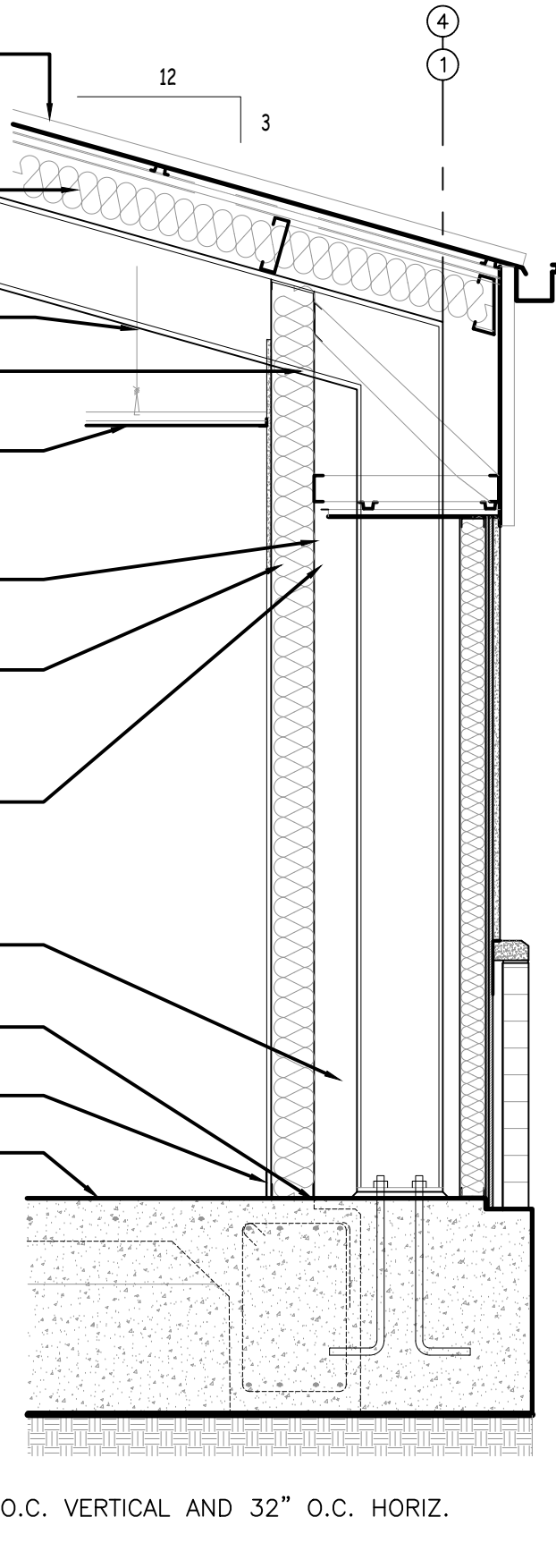

3 WALL SECTION-THRU COLUMN
 1/2" = 1' - 0"

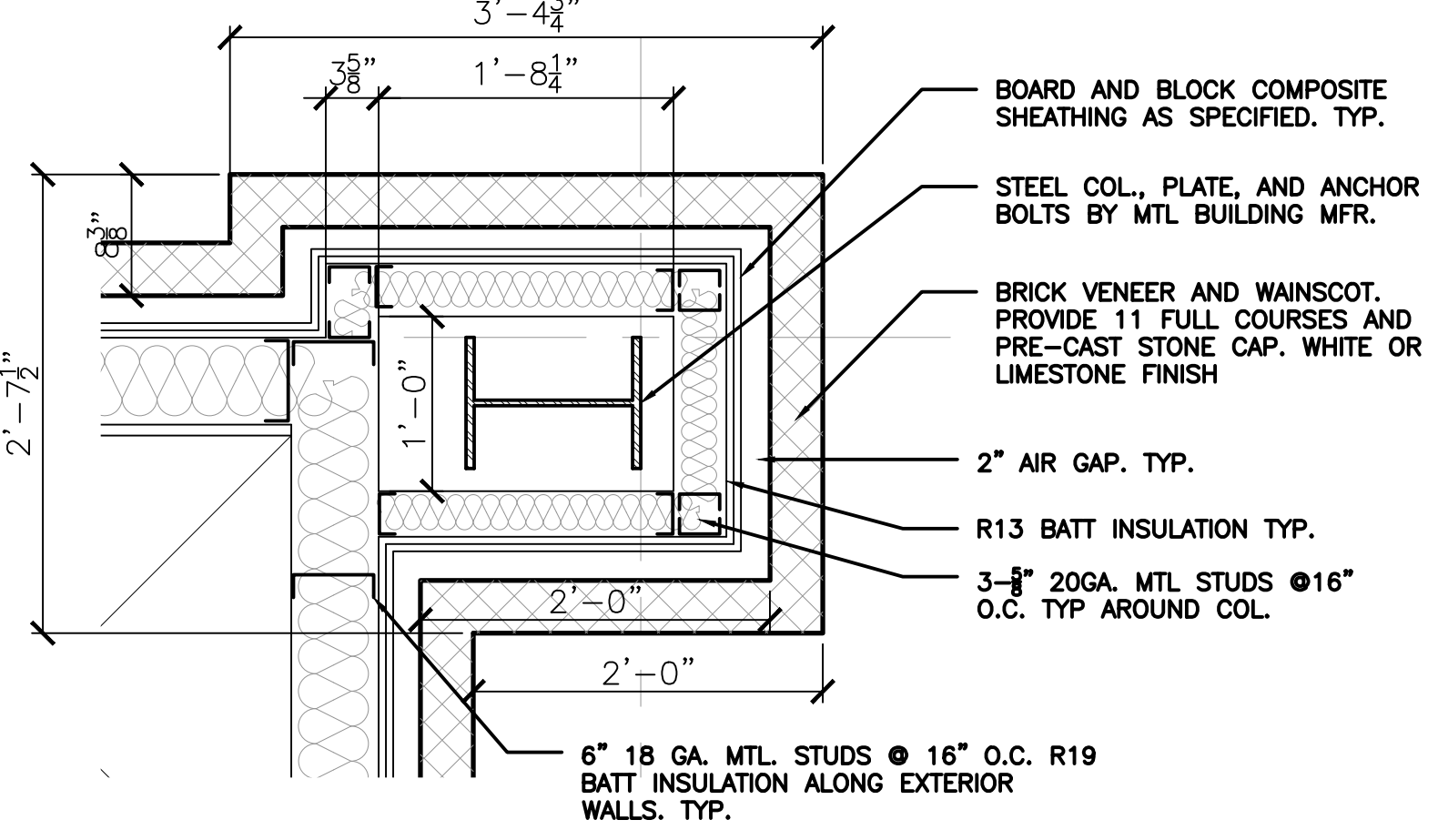

6 COL. FURRING DTL. - CORNER
 1" = 1' - 0"

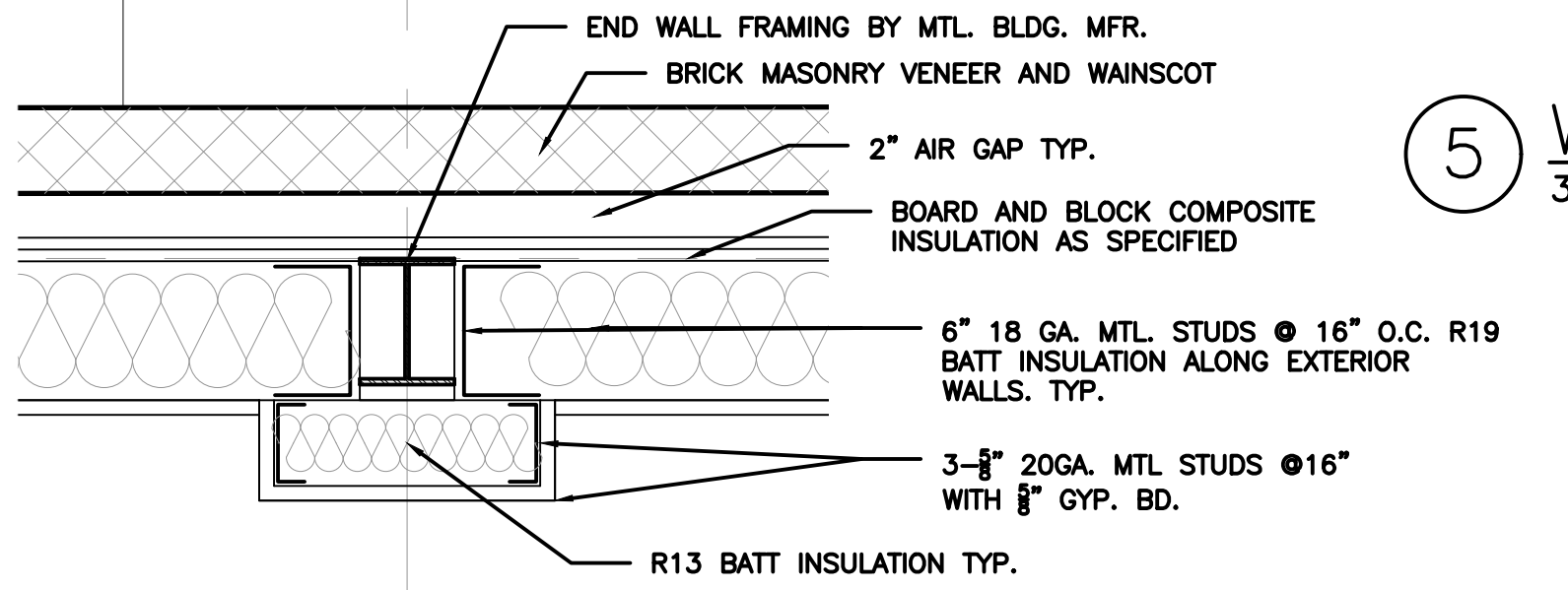

8 COL. FURRING DTL.-END WALL
 3" = 1' - 0"

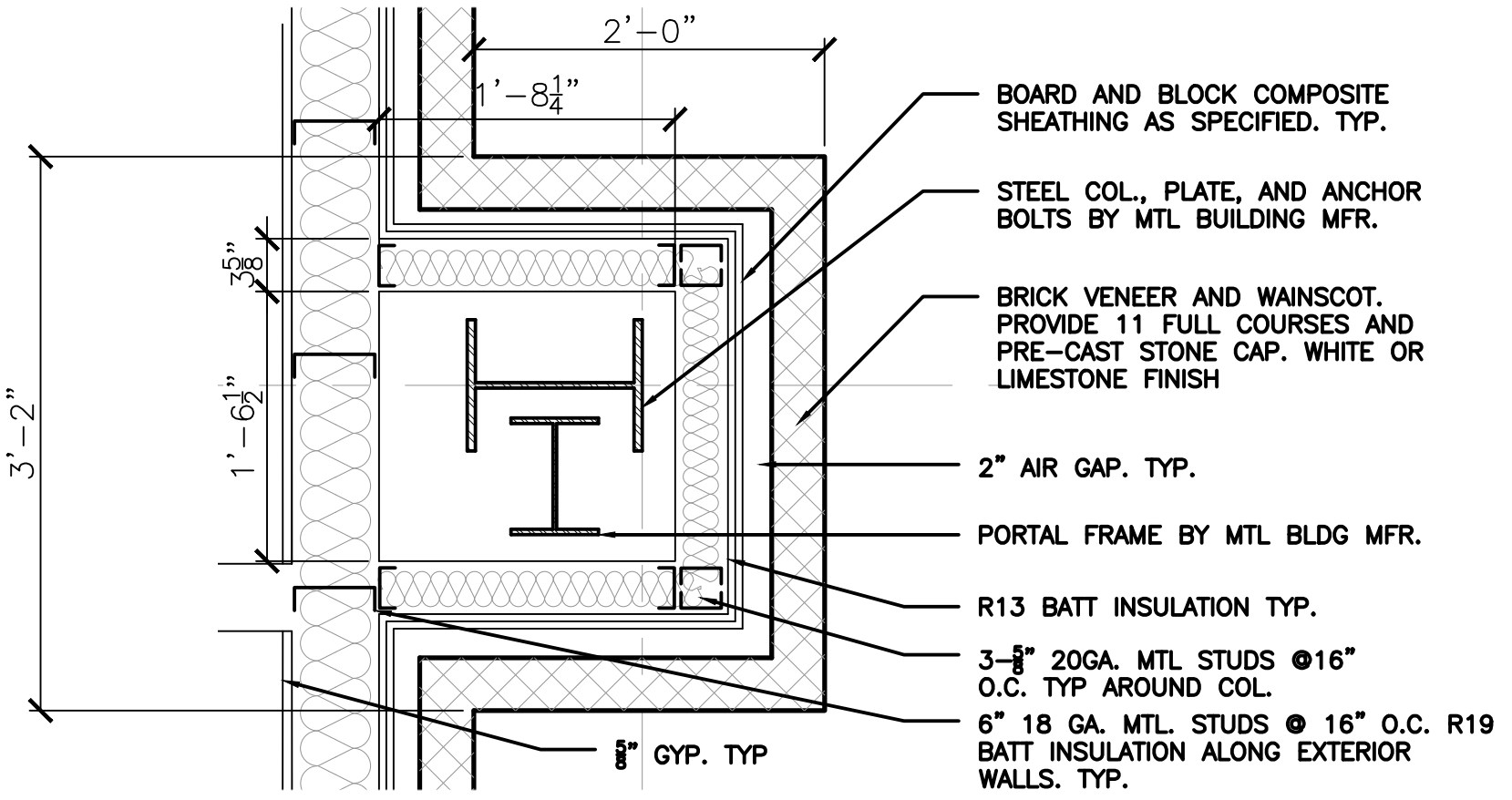

7 COL. FURRING DTL.-MIDDLE
 3" = 1' - 0"

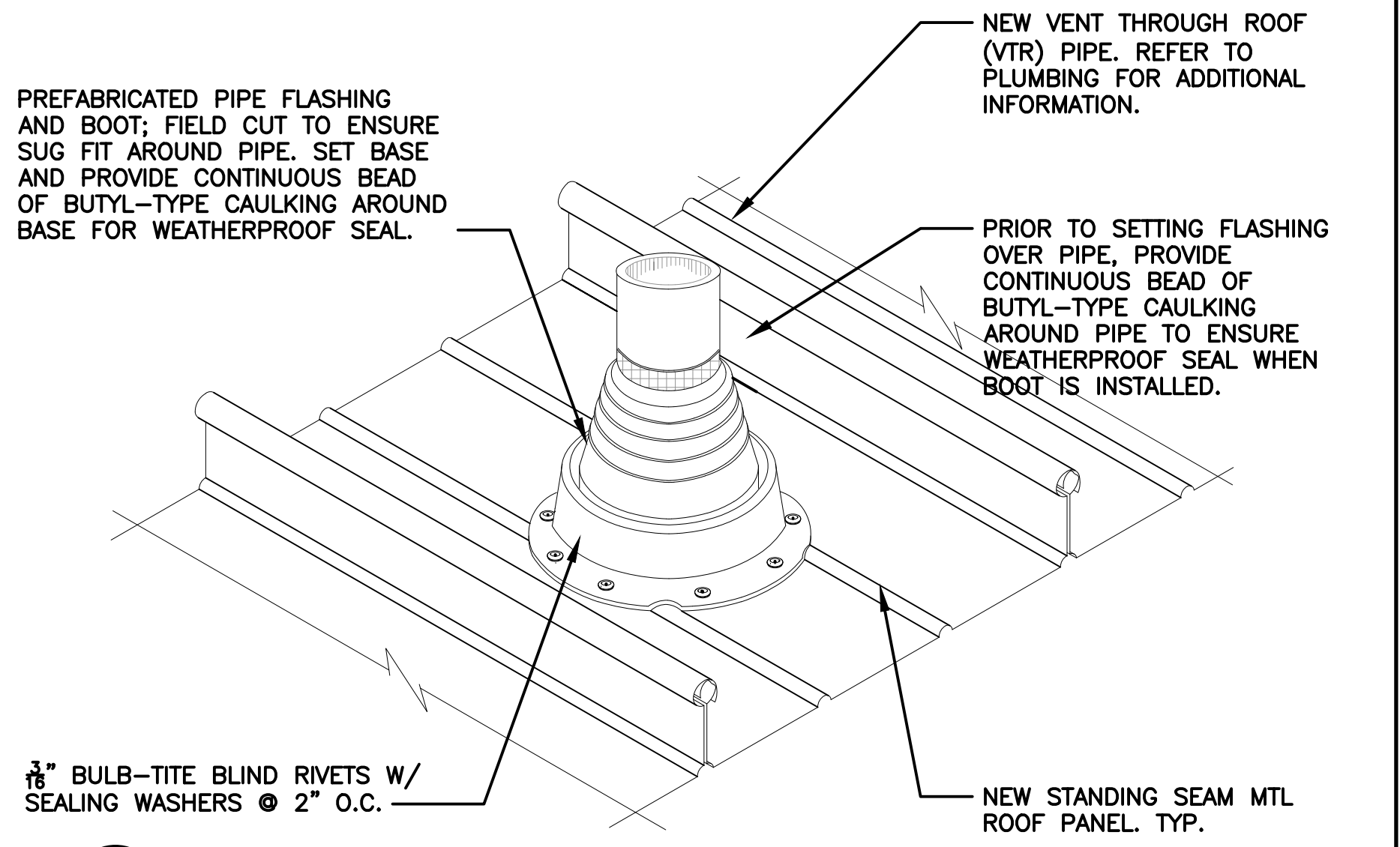

9 TUBULAR PENETRATION FLASHING DTL.
 N.T.S.

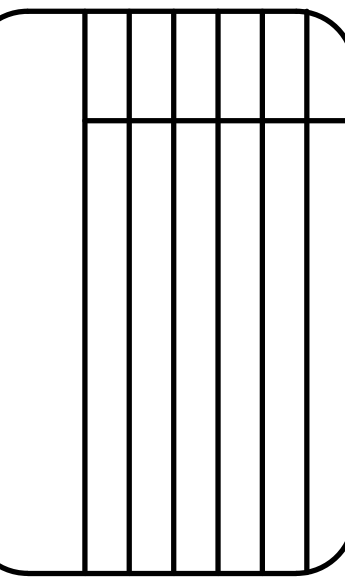

Designed by: JHR/LA
 Drawn by: JHR/LA
 Reviewed by: RTJ/JH
 Submitted by: PCES

FIRE STATION ADD/ALTER, B3321
 PROJECT NO. 1039839
 17th TRAINING WING
 GOODFELLOW AIR FORCE BASE, TEXAS

Project Number: 1039839
 SHEET TITLE: WALL SECTIONS AND DETAILS
 Date: SEP 2023

SEQ. SHEET OF
 29 A-901 50

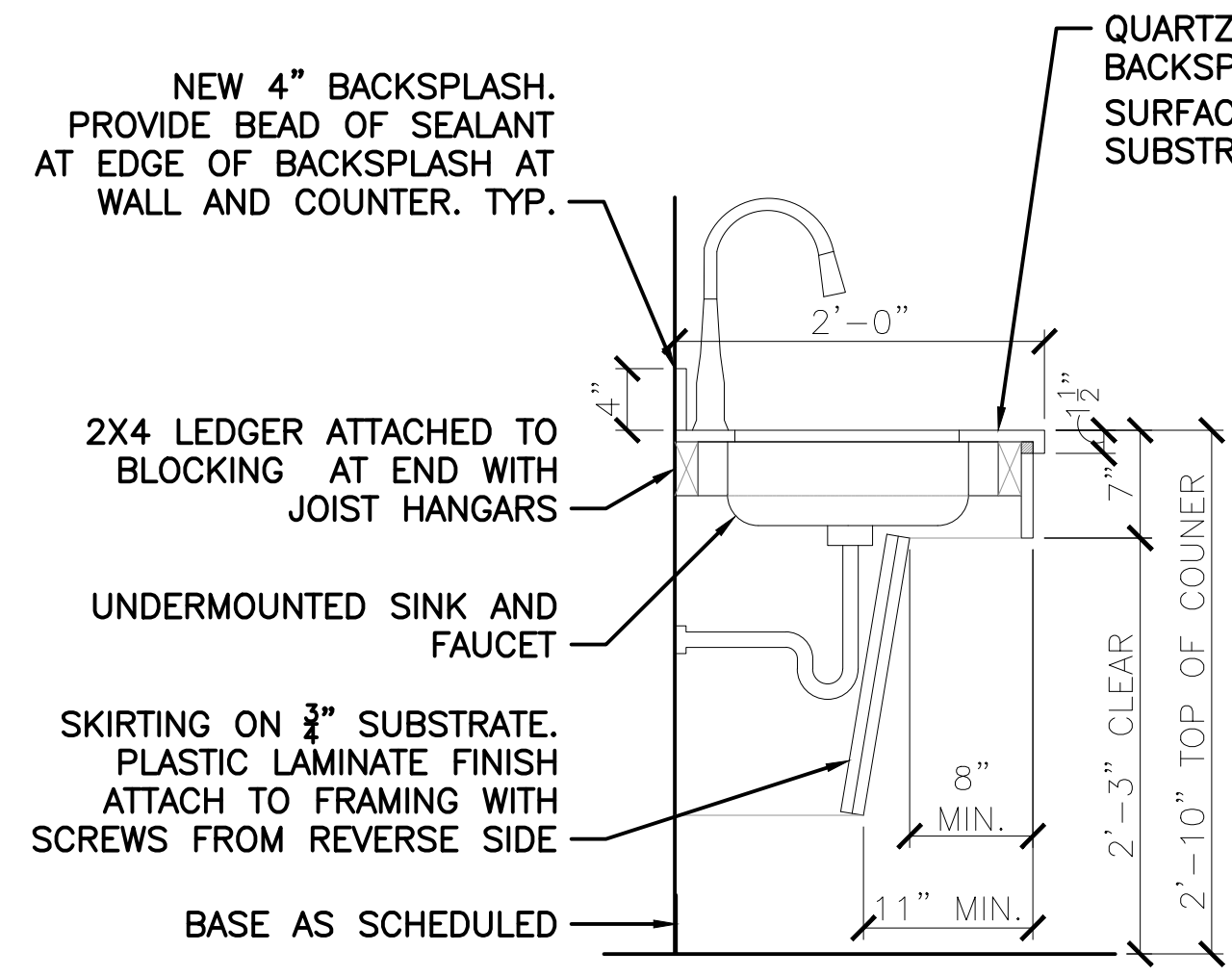
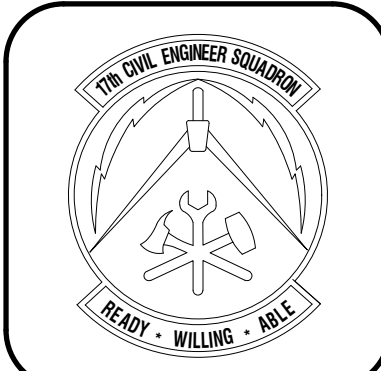

① MILLWORK DTL.
1" = 1' - 0"

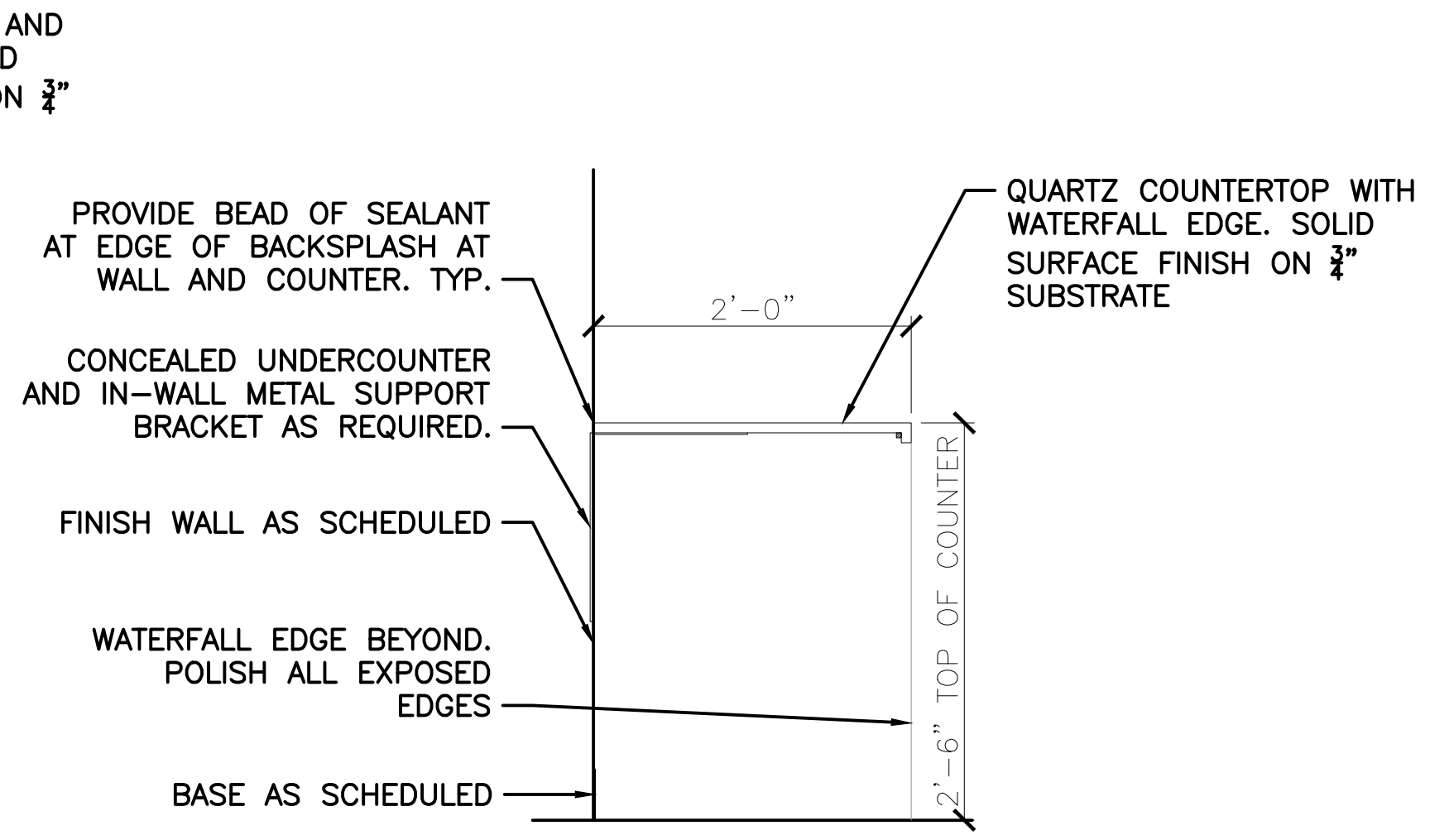

② MILLWORK DTL.
1" = 1' - 0"

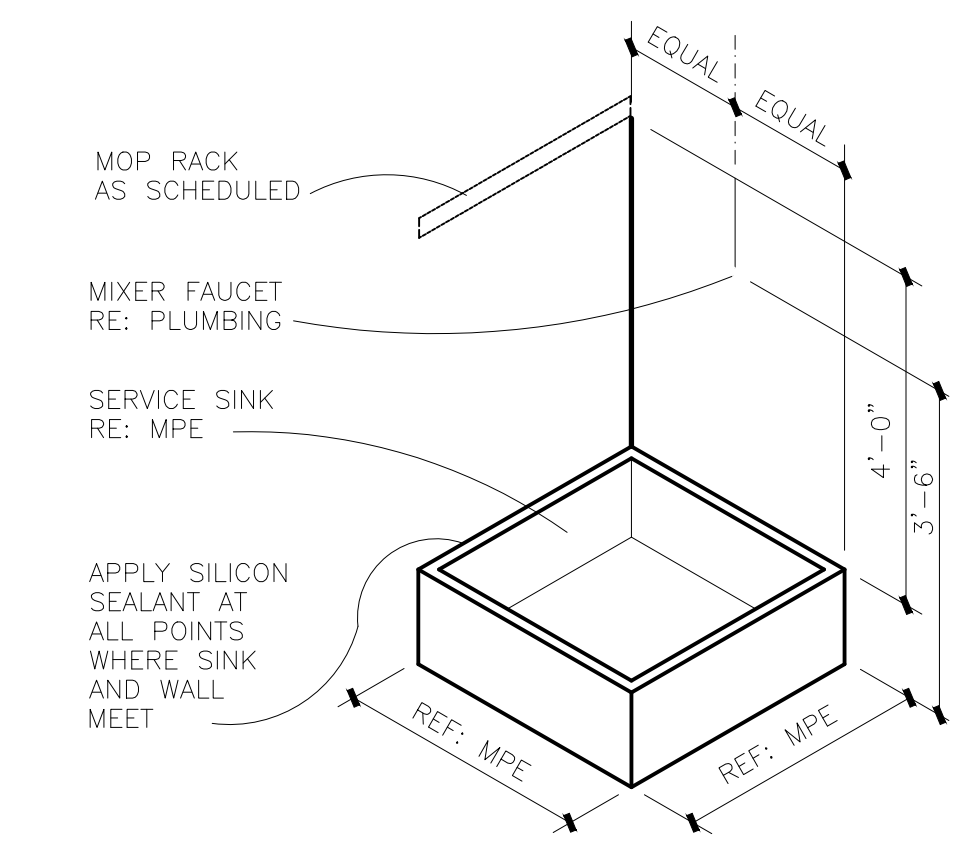

③ JAN. SINK DTL.
NTS

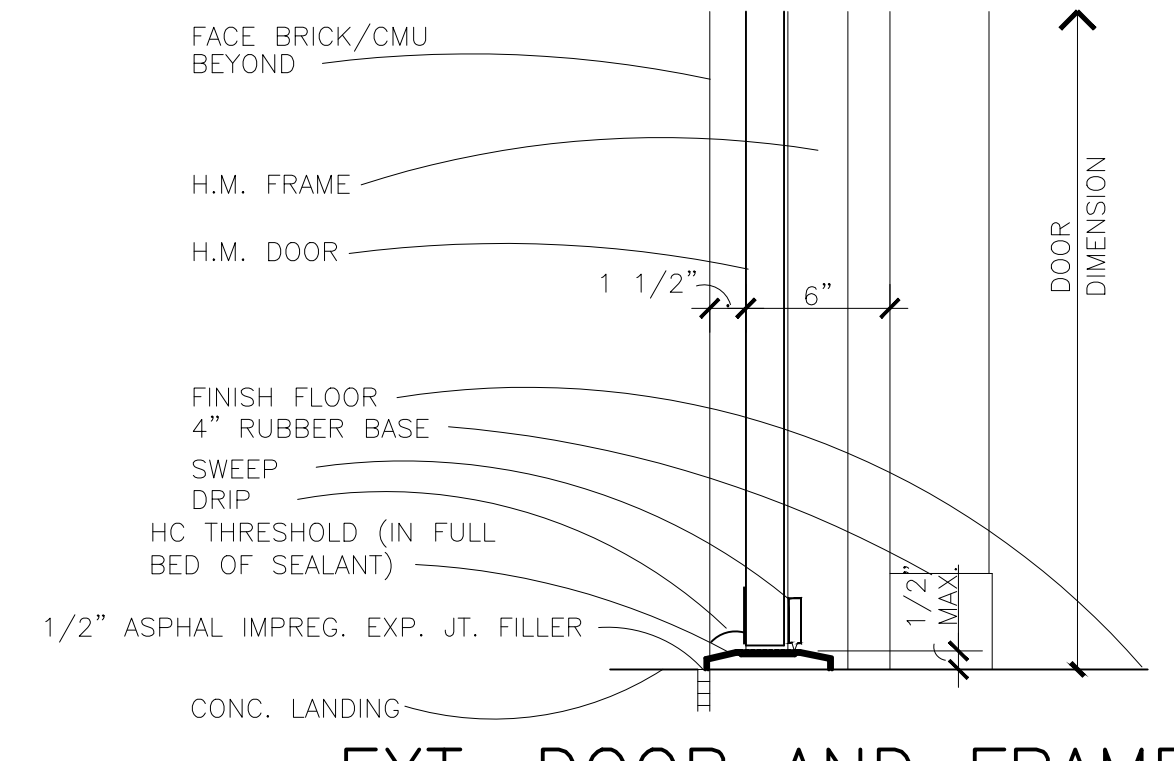

④ EXT. DOOR AND FRAME @ FLOOR
NTS

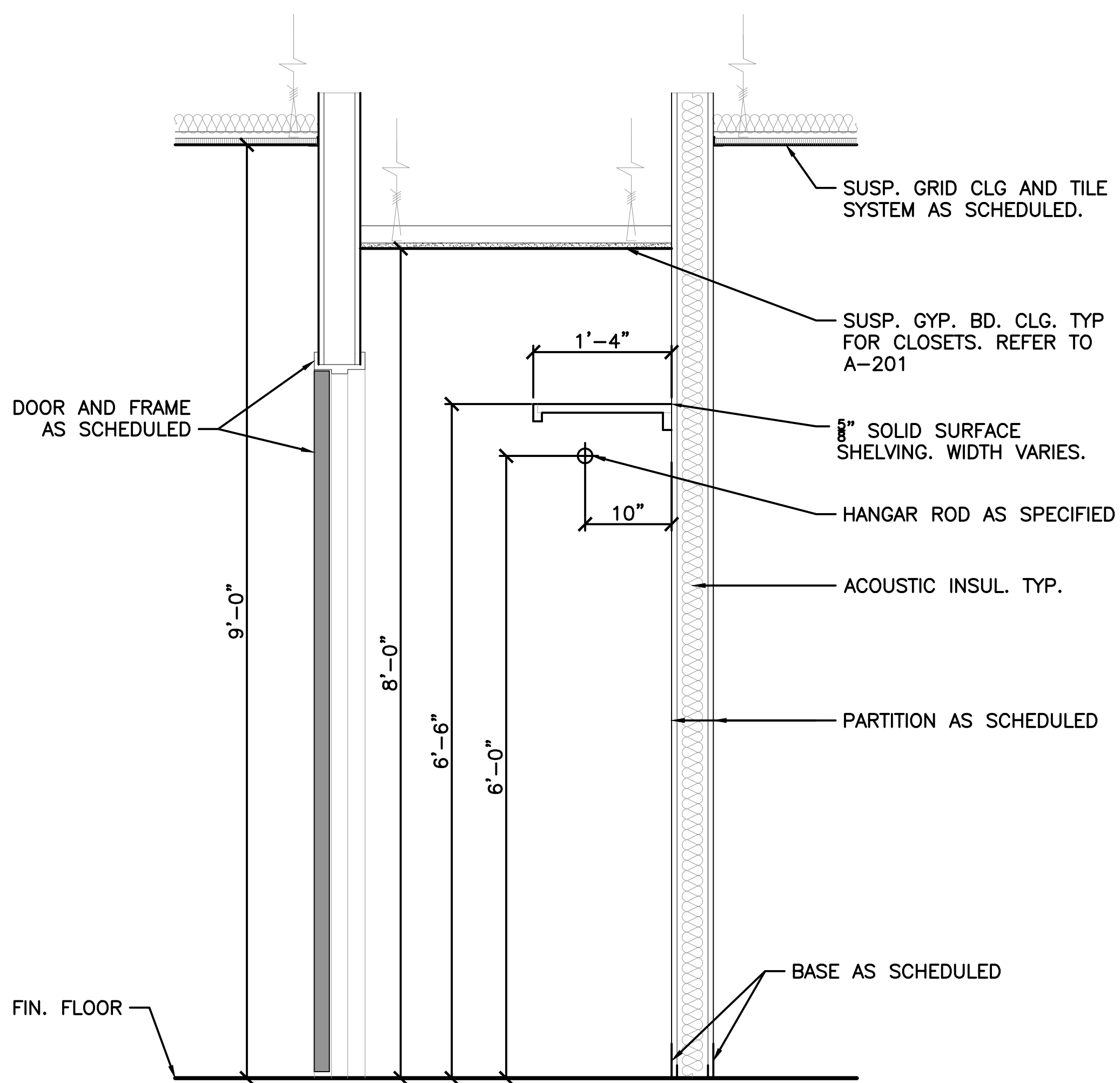

⑤ TYP. CLOSET SECTION
1" = 1' - 0"

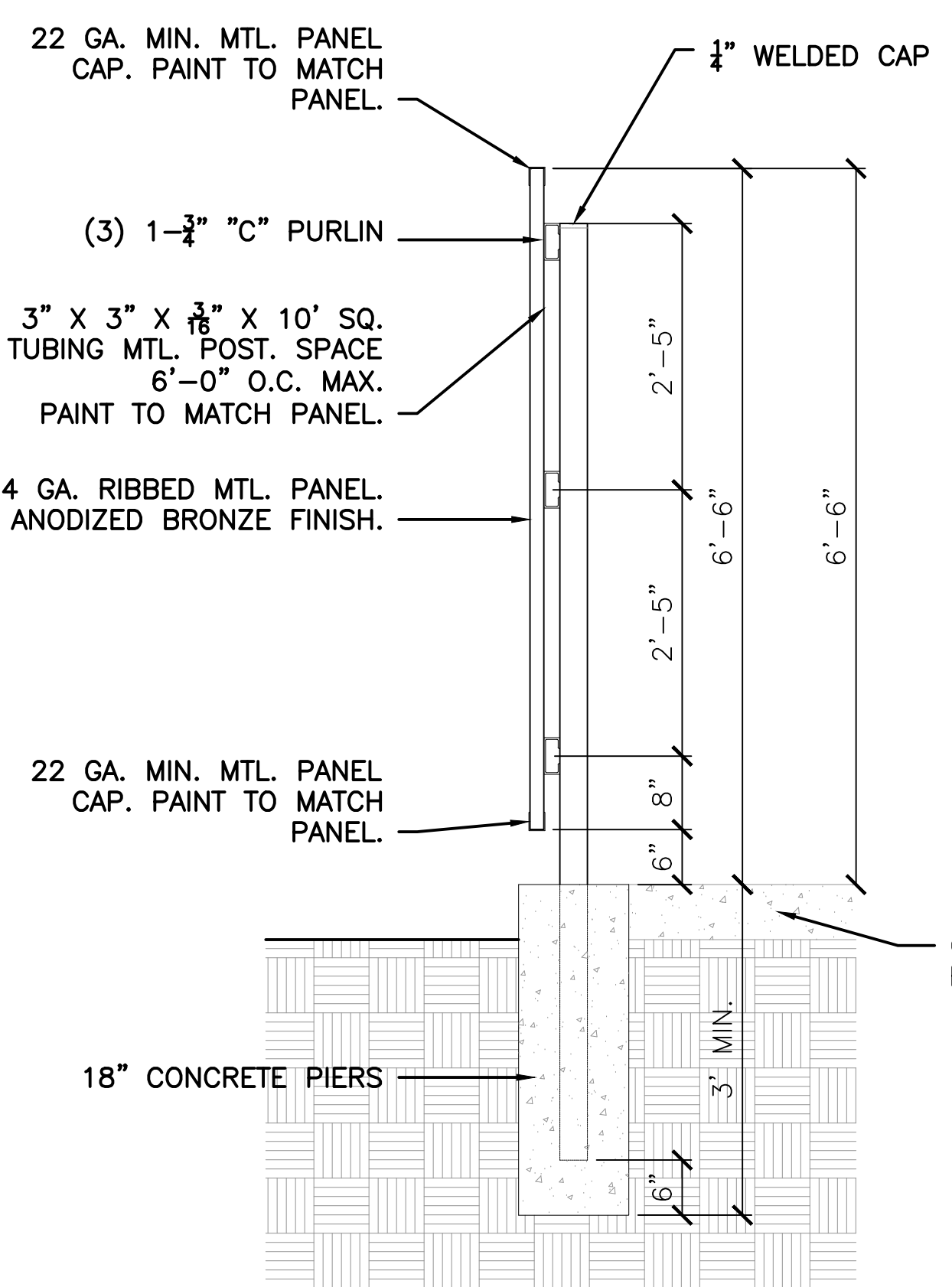

⑩ TYP. MTL. FENCE PANEL DTL.
3/4" = 1' - 0"

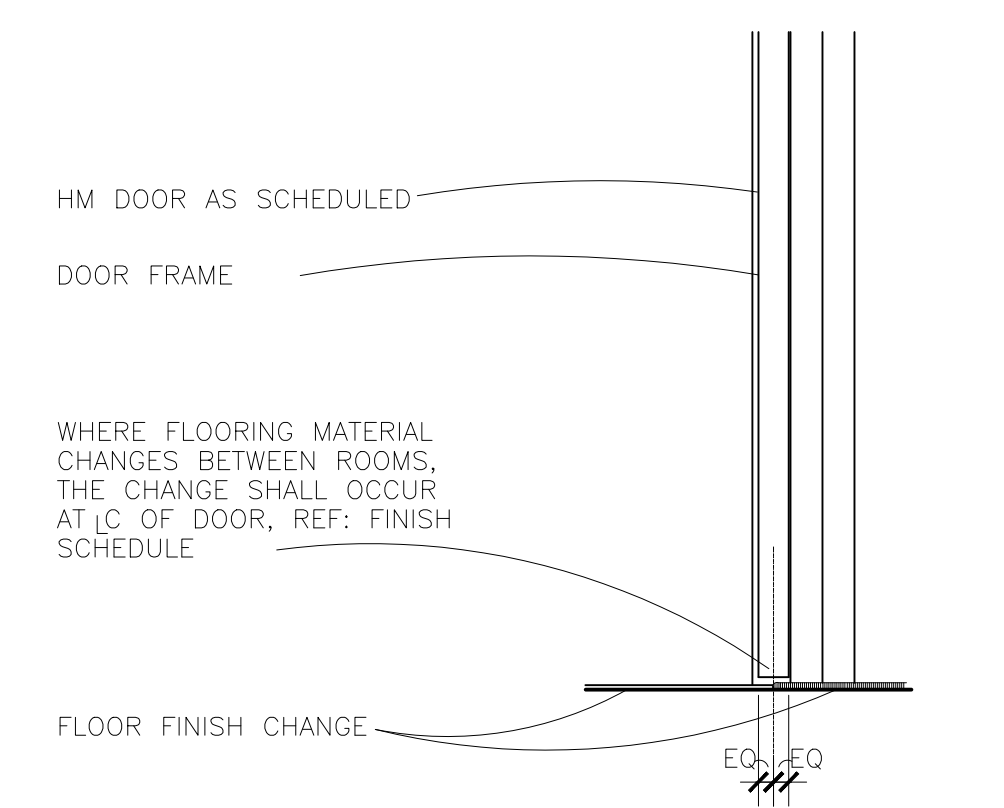

⑥ INT. DOOR & FRAME @ FLOOR
NTS

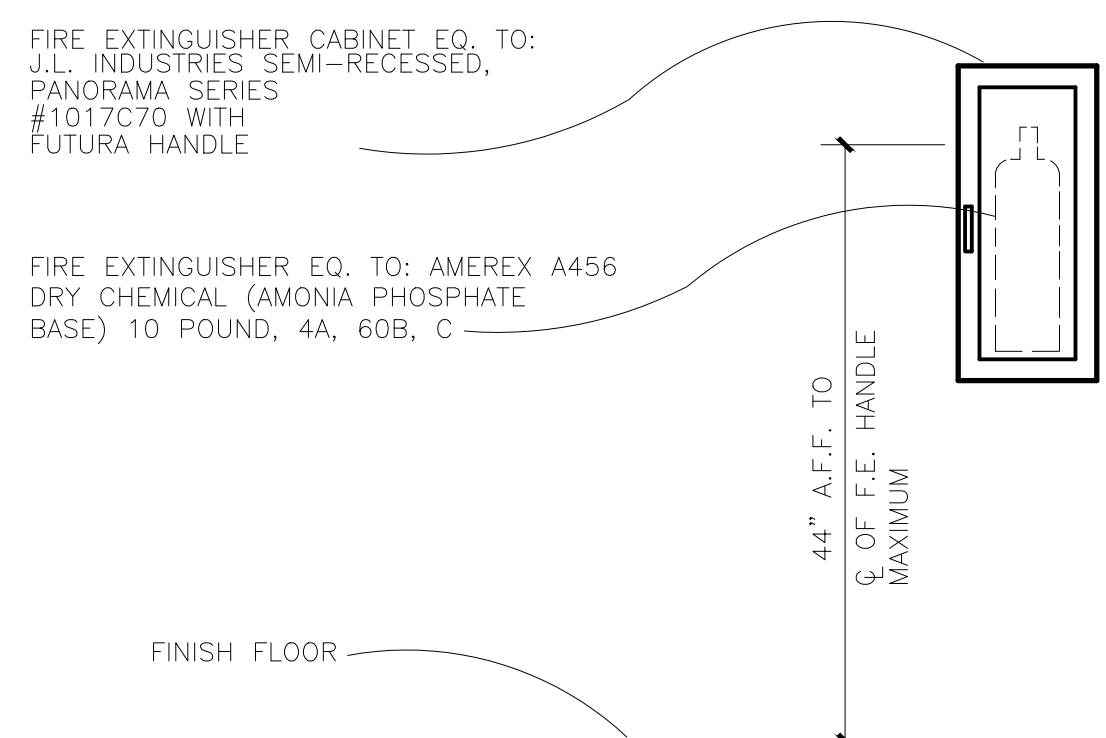

⑦ FIRE EXTINGUISHER CABINET DTL.
NTS

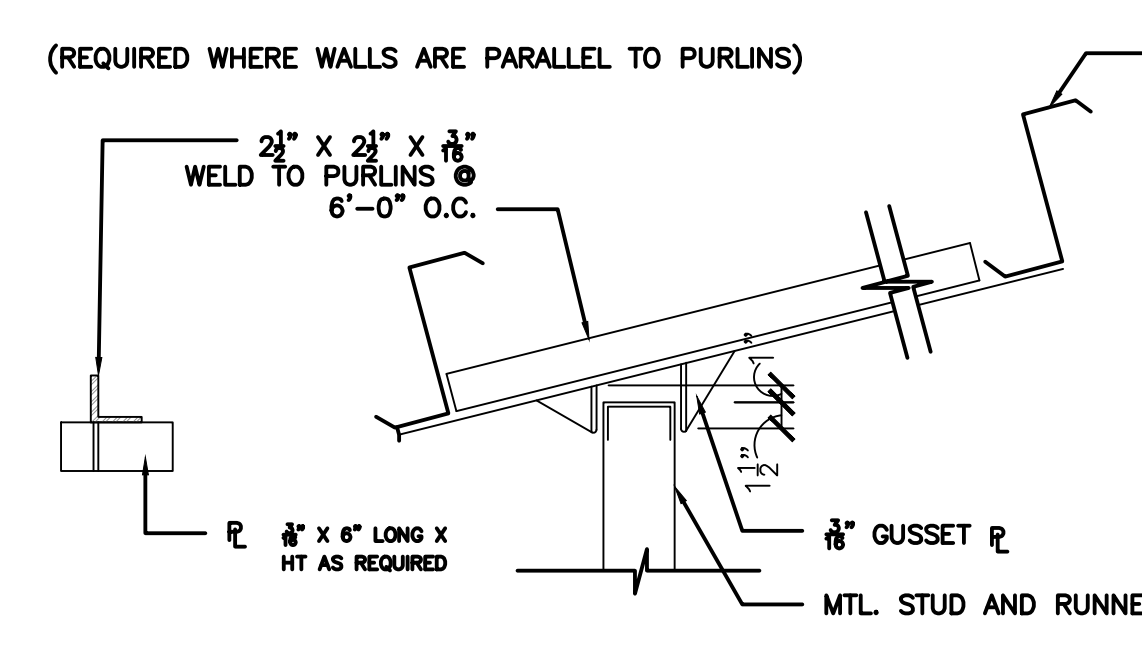

⑧ MTL. STUD PARTITION SUPPORT DTL.
1 1/2" = 1' - 0"

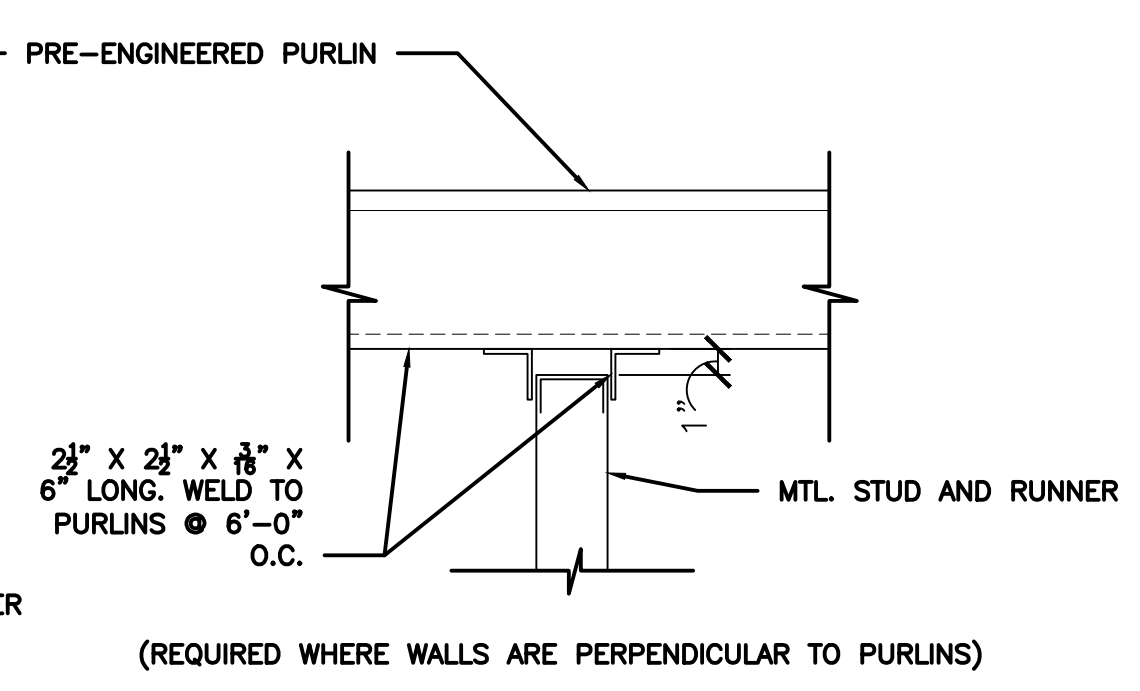

⑨ MTL. STUD PARTITION SUPPORT DTL.
1 1/2" = 1' - 0"

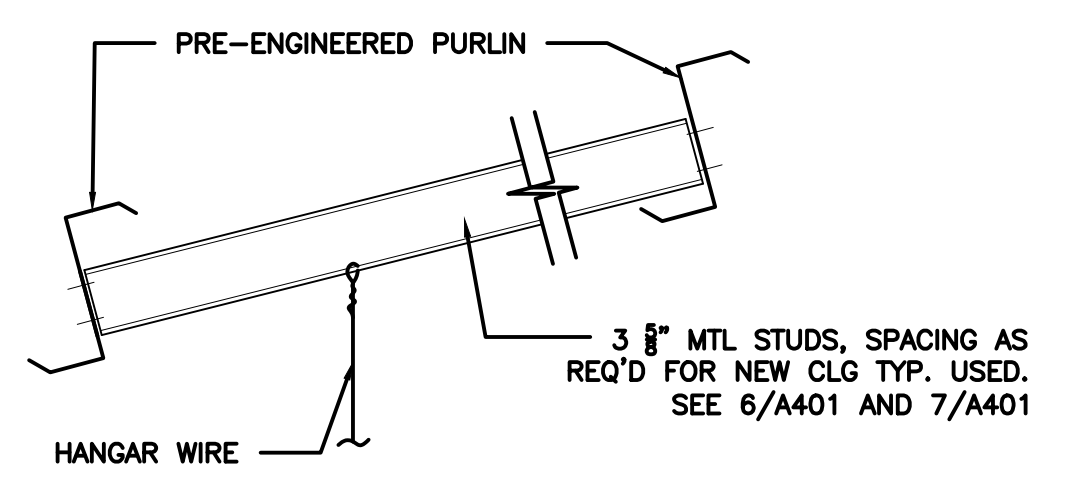

⑪ TYP. SUSP. CLG SUPPORT DTL.
1 1/2" = 1' - 0"

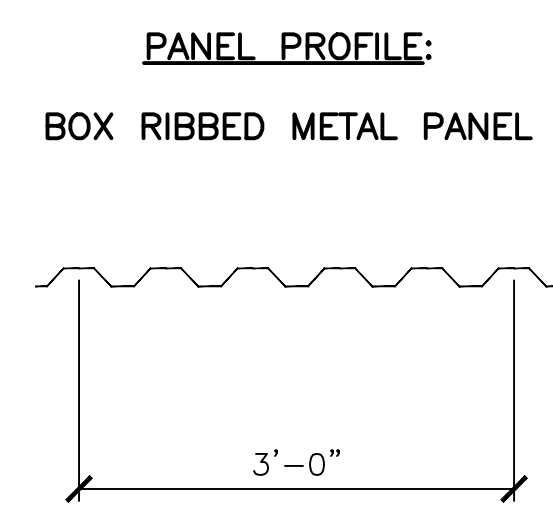

Designed by: JHR/MLA
Drawn by: JHR/MLA
Reviewed by: RTJ/JH
Submitted by: PCES

FIRE STATION ADD/ALTER, B3321
PROJECT NO. 1039839
17th TRAINING WING
GOODFELLOW AIR FORCE BASE, TEXAS

PROJECT TITLE
Project Number: 1039839
SHEET TITLE: DETAILS
Date: SEP 2023

SEQ. SHEET OF
30 A-1001 50

MECHANICAL SYMBOLS AND ABBREVIATIONS (NOT ALL APPLY)

STANDARD SYMBOLS				ABBREVIATIONS				
SYMBOL	DESCRIPTION	SYMBOL	DESCRIPTION	SYMBOL	DESCRIPTION	SYMBOL	DESCRIPTION	
PIPING-HVAC								
— PAR —	PROCESS ARGON	•••	TEE, TURNED UP	☹	BUCKET TRAP	SA	SOUND ATTENUATOR	
— CWS —	CHILLED WATER SUPPLY	— PH ₃ —	PHOSPHINE (HIGHLY TOXIC)	•••	TEE, TURNED DOWN	☉	OUTSIDE AIR (O. A.)	
— CWR —	CHILLED WATER RETURN	— PN ₂ —	PROCESS NITROGEN	→•••	VALVE IN RISER	▭	ACOUSTICAL LINING (A.L.)	
— HWS —	HEATING WATER SUPPLY	— R12 —	DICHLORODIFLUOROMETHANE	→•••	VALVE ON ELBOW UP	⊙	EXHAUST FAN	
— HWR —	HEATING WATER RETURN	— R14 —	TETRAFLUOROMETHANE	→•••	VALVE ON ELBOW DOWN	⊙	SUPPLY FAN	
— TWS —	TOWER WATER SUPPLY	— Si ₂ H ₆ —	DISILANE (PYROPHORIC/TOXIC)	↘	45 ELBOW	⊙	VENT FAN	
— TWR —	TOWER WATER RETURN	— SiH ₄ —	SILANE (PYROPHORIC/TOXIC)	↘	30 ELBOW	▭	FLEXIBLE DUCT CONNECTION	
— LPS —	LOW PRESSURE STEAM	PIPING-GASES		└	90 ELBOW	☹	FINNED PIPE RADIATION	
— MPS —	MEDIUM PRESSURE STEAM	— AR —	ARGON	├	TEE	☹	RECTANGULAR OUTLET, EXHAUST	
— HPS —	HIGH PRESSURE STEAM	— BA —	BREATHING AIR	└┘	CAP	☹	SIDEWALL OUTLET, REGISTERS/GRILLES	
— C —	CONDENSATE, GRAVITY	— CA —	COMPRESSED AIR	⊖	RUPTURE DISK	☹	SIDEWALL INLET, REGISTERS/GRILLES	
— PC —	CONDENSATE, PUMPED	— CDA —	CLEAN DRY AIR	⊖	SHOCK ABSORBER	⊞	RELAY	
— FOS —	FUEL OIL SUPPLY	— CH ₄ —	METHANE	●	FLOOR DRAIN	☹	TEMPERATURE SWITCH	
— FOR —	FUEL OIL RETURN	— C ₂ H ₂ —	ACETYLENE	■	FLOOR SINK	☹	THERMOMETER (WITH TEMPERATURE RANGE)	
— FOG —	FUEL OIL GAGE LINE	— CO ₂ —	CARBON DIOXIDE	⊖	EXPANSION JOINT	☹	VENTURI FLOW METER	
— FOV —	FUEL OIL TANK VENT	— G —	NATURAL GAS	⊖	LINE STRAINER	— E —	ELECTRIC	
— RD —	REFRIGERANT DISCHARGE (HOT GAS)	— H ₂ —	HYDROGEN	☹	CLEAN-OUT TO GRADE	☹	SMOKE DETECTOR, DUCT	
— RS —	REFRIGERANT SUCTION	— HCW —	HOUSE CLEANING VACUUM	⊖	OPEN SIGHT DRAIN, AIR GAP	☹	FIRE DETECTOR, DUCT	
— RL —	REFRIGERANT LIQUID	— HE —	HELIUM	⊖	WALL CLEANOUT (WCO)	☹	FIRE/SMOKE DETECTOR, DUCT	
---NAME---	DEMO PIPE	— LAR —	LIQUID ARGON	☹	FLOOR CLEANOUT (FCO)	⊞	T-STAT, ELECTRONIC	
(E) NAME	EXISTING PIPE	— LC0 ₂ —	LIQUID CARBON DIOXIDE	→	DIRECTION AND FLOW	⊞	T-STAT, PNEUMATIC	
PIPING-PLUMBING								
————	COLD WATER	— LN ₂ —	LIQUID NITROGEN	☹	VALVES	⊞	T-STAT, SENSOR	
————	HOT WATER	— LO ₂ —	LIQUID OXYGEN					⊞
-----	HOT WATER RETURN	— LPG —	LIQUID PETROLEUM GAS	⊖	BALL VALVE	☹	DAMPER, ELECTRIC	
— W —	WATER	— N ₂ —	NITROGEN	⊖	GATE VALVE	☹	DAMPER, PNEUMATIC	
— NPW —	NON POTABLE WATER	— O ₂ —	OXYGEN	⊖	GLOBE VALVE	☹	RECTANGULAR OUTLET, RETURN	
-----	SANITARY SEWER	— PV —	PROCESS VACUUM	⊖	PLUG COCK	☹	RECTANGULAR OUTLET, EXHAUST	
-----	VENT	— VAG —	VACUUM	↔	SWING CHECK VALVE	☹	ROUND OUTLET	
— D —	GRAVITY DRAIN	PIPING-PROCESS LIQUIDS		↔	SPRING CHECK VALVE	☹	LINEAR OUTLET (SIZE=NUMBER SLOTS X LENGTH OF SLOTS)	
— PD —	PRESSURE DRAIN	— DI —	DEIONIZED WATER	↔	HOSE BIBB	☹	LINEAR INLET (SIZE=NUMBER SLOTS X LENGTH OF SLOTS)	
— AD —	ACID WASTE, GRAVITY	— HF —	HYDROFLUORIC ACID	↔	NEEDLE VALVE	☹	LIGHT TROFFER OUTLET	
— AV —	ACID VENT	— PCWR —	PROCESS COLD WATER RETURN	↔	BUTTERFLY VALVE	☹	MISCELLANEOUS	
— PAD —	ACID DRAIN, PUMPED	— PCWS —	PROCESS COLD WATER SUPPLY	↔	MOTOR OPERATED GLOBE VALVE	☹	CENTRIFUGAL PUMP	
— RWL —	RAIN WATER LEADER	— POR —	PROCESS OIL RETURN	↔	MOTOR OPERATED GATE VALVE	☹	NUMBER DETAIL BUBBLE	
— ORWL —	OVERFLOW RAIN WATER LEADER	— POS —	PROCESS OIL SUPPLY	↔	SOLENOID OPERATED VALVE	☹	EQUIPMENT MARK (AHU-1 SHOWN)	
— ST —	STORM SEWER	— RO —	REVERSE OSMOSIS WATER	↔	SOLENOID OPERATED 3-WAY VALVE	☹	END POINT OF REMOVAL	
— S —	SOFT WATER	— SCW —	SOFTENED COLD WATER	↔	SELF-CONTAINED TEMP. CONTROL VALVE	☹	KEYED NOTE CONSTRUCTION	
-----	DEMO PIPE	PIPING-FITTINGS		↔	EXTERNAL, PRESSURE REDUCING VALVE	☹	MANHOLE	
-----	EXISTING PIPE	├	SCREWED JOINT	↔	INTERNAL, PRESSURE REDUCING VALVE	☹	POINT OF CONNECTION FROM NEW TO EXISTING CONSTRUCTION	
PIPING-SPECIALTY								
— AsH ₃ —	ARSINE (HIGHLY TOXIC)	├	FLANGED JOINT	↔	THREE WAY VALVE, ELECTRICAL	☹	LETTER SECTION BUBBLE	
— Cl ₂ —	CHLORINE (CORROSIVE)	├	WELDED JOINT	↔	THREE WAY VALVE, MANUAL	☹	BREAK	
— DMC —	DIMETHYLCADMIUM (METAL ORGANIC)	├	UNION	↔	THREE WAY VALVE, PNEUMATIC	☹	KEYED NOTE, DEMOLITION	
— DMT —	DIMETHYLTELLURIUM (METAL ORGANIC)	├	CONCENTRIC REDUCER	↔	ANGLE VALVE	☹	METER	
— H ₂ Se —	HYDROGEN SELENIDE (TOXIC)	├	ECCENTRIC REDUCER	↔	RELIEF VALVE	☹	TITLE	
— HCL —	HYDROGEN CHLORIDE (CORROSIVE)	├	ELBOW, TURNED DOWN	↔	DIAPHRAGM VALVE	☹	NOT TO SCALE	
— NH ₃ —	AMMONIA (TOXIC)	├	ELBOW, TURNED UP	↔	BACKFLOW PREVENTER	☹	DETAIL BUBBLE	
— F —	FLUORINE	☹	AIR VENT	↔	F & T TRAP	☹	TITLE — INDICATES THE TITLE OF THE DETAIL SCALE — INDICATES THE SCALE OF THE DETAIL (IF APPLICABLE) X — DENOTES DETAIL NUMBER Y — DENOTES REFERENCE SHEET NUMBER Z — DENOTES SHEET NUMBER	
— F —	FLUORINE	☹	VACUUM RELIEF	↔	THERMOSTATIC TRAP	☹		

GENERAL NOTES:

THESE MECHANICAL GENERAL NOTES APPLY TO ALL MECHANICAL DRAWINGS:

- ALL WORK SHALL BE PERFORMED IN ACCORDANCE WITH THE CODES AS REFERENCED IN THE RFP AND THE REQUIREMENTS STATED IN THE APPLICABLE SECTIONS OF THE NATIONAL FIRE CODES (NFPA STANDARDS) CURRENT AT THE TIME OF ISSUANCE OF THE RFP. AMENDMENTS TO THESE CODES AS SET FORTH BY THE AUTHORITY HAVING JURISDICTION SHALL SUPERSEDE THE INTERNATIONAL CODES AND NFPA STANDARDS AS ISSUED.
- DIVISION 23 OPERATIONS SHALL BE SUPERVISED BY A LICENSED MASTER MECHANICAL INSTALLER TO ENSURE THAT ALL WORK IS INSTALLED IN ACCORDANCE WITH THE APPLICABLE CODES AND THE CONSTRUCTION DOCUMENTS.
- EXISTING INFORMATION SHOWN WAS TAKEN FROM AS BUILT DRAWINGS PROVIDED BY GOODFELLOW AIR FOR BASE (GAFB) AND A WALK-THRU OF THE FACILITY. THE CONTRACTOR SHALL FIELD VERIFY THE EXISTING CONDITIONS PRIOR TO BID AND NOTIFY THE CONTRACTING OFFICER OF ANY SUBSTANTIAL DISCREPANCIES WHICH WOULD IMPACT BASIS OF DESIGN AND CONSTRUCTION.
- CONTRACTOR SHALL VISIT THE JOB SITE TO FAMILIARIZE THEMSELVES WITH EXISTING CONDITIONS AND TO VERIFY LOCATIONS, SIZE AND QUANTITIES OF EXISTING UTILITIES, MECHANICAL SYSTEMS, PLUMBING SYSTEMS, ETC. SUBMITTAL OF A BID SHALL SIGNIFY WILLINGNESS TO COMPLY WITH THE CONSTRUCTION DOCUMENTS AND ACCEPTANCE OF ON-SITE CONDITIONS AS THEY EXIST.
- THE INSTALLER IS RESPONSIBLE FOR COORDINATING WITH OTHER TRADES. THE INSTALLER SHALL NOT INSTALL OR FABRICATE ANY WORK SHOWN UNTIL ALL SUCH WORK IS FULLY COORDINATED. FURNISH AND INSTALL ADDITIONAL DUCTWORK, PIPING, OFFSETS, AND FITTINGS AS REQUIRED TO COORDINATE THE INSTALLATION WITH OTHER TRADES AS PART OF THE WORK.
- COORDINATE WITH AND OBTAIN APPROVAL FROM CONTRACTING OFFICER FOR ALL UTILITY OUTAGES A MINIMUM OF 7 DAYS IN ADVANCE.
- SECURE OPENINGS THROUGH WALLS, ROOFS AND FLOORS FROM WEATHER DURING CONSTRUCTION.
- SECURE OPENINGS THROUGH ROOFS AND FLOORS FROM FALL AND PROVIDE ALL APPROPRIATE FALL PROTECTION MEASURES PER OSHA REQUIREMENTS.
- SALVAGE EQUIPMENT ITEMS TO A DESIGNATED STORAGE OR DISPOSAL AREA AS DIRECTED BY THE CONTRACTING OFFICER.
- COVER ALL DUCTWORK OPENING DURING CONSTRUCTION TO PREVENT MIGRATION OF DUST.
- INSTALL CONSTRUCTION FILTERS AT ALL RETURN OPENINGS OF ALL EQUIPMENT DURING CONSTRUCTION TO PREVENT MIGRATION OF DUST.
- ALL PIPING AND CUT IN FINISHED ROOMS OR SPACES SHALL BE CONCEALED IN A FURRED CHASE OR ABOVE THE SUSPENDED CEILING.
- THE FIRST DUCT SIZE INDICATES THE DIMENSION OF FACE SHOWN ON PLAN VIEW ONLY.
- ACCESS PANELS IN GYP BOARD CEILINGS ARE REQUIRED FOR ALL VALVES, TRAPS, DAMPERS, CLEANOUTS, CONTROLS, ETC. UNLESS OTHERWISE SPECIFIED THE ACCESS PANELS SHALL BE 16 GAGE PAINTABLE STEEL CONSTRUCTION WITH A PIANO HINGED DOOR, FLANGE FRAME, WALL SLEEVE AND KEYS LOCK. THE PANELS IN EXPOSED, FINISHED AREAS SHALL BE STAINLESS STEEL. THE ACCESS PANELS IN FIRE RATED ASSEMBLIES SHALL HAVE THE SAME RATING AS THE ASSEMBLY.
- EXTERNAL STATIC PRESSURE NOTED THE ON THE SCHEDULES ONLY INCLUDES SYSTEM LOSSES AND EXCLUDES LOSSES DUE TO ITEMS IN THE UNIT ITSELF SUCH AS (COILS, CASING, DAMPERS AND CLEAN FILTERS)
- DIFFUSERS RESISTER AND GRILLE SIZES SHOWN ON THE FLOOR PLAN ARE NECK SIZES.
- REFER TO THE ARCHITECTURAL REFLECTED CEILING PLANS FOR EXACT LOCATIONS OF CEILING DIFFUSER, REGISTER AND GRILLES.
- IF A DAMPER IN THE DUCT IS LOCATED ABOVE A HARD CEILING FURNISH AND INSTALL A ROUND DAMPER YOUNG REGULATOR 5020-1200 OR EQUIVALENT WITH WORM GEAR REGULATOR USE WITH FLEXIBLE SHAFT AND CONCEALED CEILING CAP WITH BRACKET FASTENS ABOVE THE CEILING ACCESS THROUGH A 1" ZINC PLATED THREADED STEEL CAP. PAINT SHALL BE APPROVED BY THE CONTRACTING OFFICER BEFORE PAINTING THE CAP TO MATCH CEILING COLOR.
- THE DRAWINGS ARE PART DIAGRAMMATIC IN NATURE AND THE CONTRACTOR SHALL BE RESPONSIBLE TO COORDINATE ALL NEW PIPING, NEW DUCTS, NEW EQUIPMENT WITH THE EXISTING CONDITIONS SUCH AS PIPING, EQUIPMENT, STRUCTURAL COMPONENTS AND ETC. PRIOR TO SUBMISSION OF PIPING LAYOUT SHOP DRAWINGS AND COMMENCEMENT OF WORK. CONTRACTOR SHALL FURNISH AND INSTALL ALL BENDS, OFFSETS, ADDITIONAL PIPING WALL PENETRATIONS, EXISTING PIPE RE-ROUTING ETC. AS REQUIRED TO CONFIRM WITH EXISTING CONDITIONS AND TO PROVIDE A FULLY FUNCTIONAL SYSTEMS.
- THESE DRAWINGS ARE ACCOMPANIED BY SPECIFICATIONS OF THE BUILDING AND DETAILS OF THE INSTALLATIONS INDICATING THE LOCATIONS OF EQUIPMENT, PIPING, DUCTWORK, OUTLETS, LIGHT FIXTURES, ETC. ITEMS SPECIFICALLY MENTIONED IN THE SPECIFICATIONS BUT NOT SHOWN ON THE DRAWINGS AND ITEMS SHOWN ON THE DRAWINGS BUT NOT SPECIFICALLY MENTIONED IN THE SPECIFICATIONS SHALL BE INSTALLED BY THE CONTRACTOR UNDER THE APPROPRIATE SECTION OR WORK AS IF THEY WERE INDICATED BY BOTH.
- THE SPECIFICATIONS DETERMINE THE NATURE AND SETTING OF THE SEVERAL MATERIALS, THE DRAWINGS ESTABLISH THE QUANTITIES, DIMENSIONS, DETAILS AND THE SCHEDULES WHICH GIVE THE PERFORMANCE CHARACTERISTICS.
- SHOULD THE DRAWINGS DISAGREE IN THEMSELVES AND WITH THE SPECIFICATIONS AND WITH VARIOUS CODES AND REGULATIONS, THE BETTER QUALITY OR GREATER QUANTITY OF WORK OR MATERIALS SHALL BE ASSUMED AND ESTIMATED AND UNLESS OTHERWISE DIRECTED BY THE CONTRACTING OFFICER AND ENGINEER IN WRITING SHALL BE PERFORMED OR FURNISHED. IN CASE THE SPECIFICATIONS SHOULD NOT FULLY AGREE WITH THE SCHEDULES, THE LATER SHALL GOVERN.

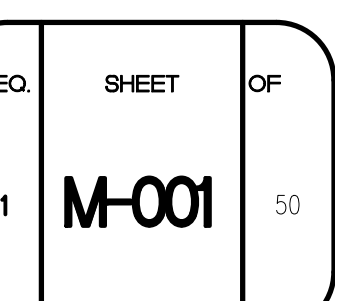
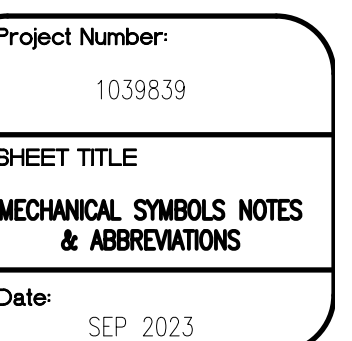
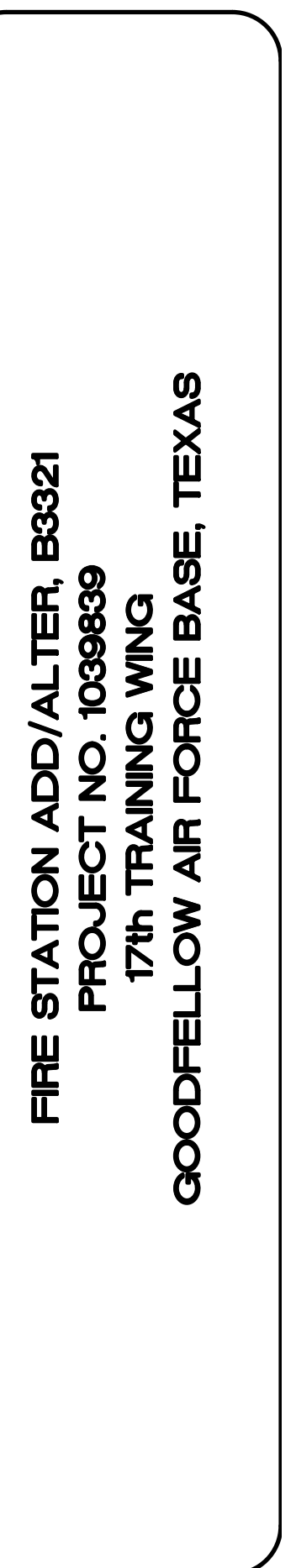
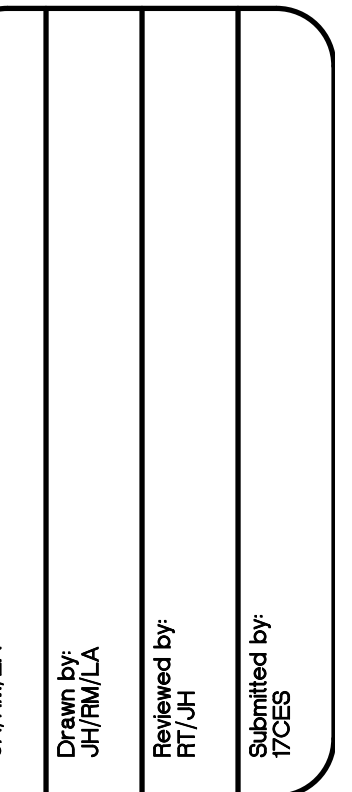
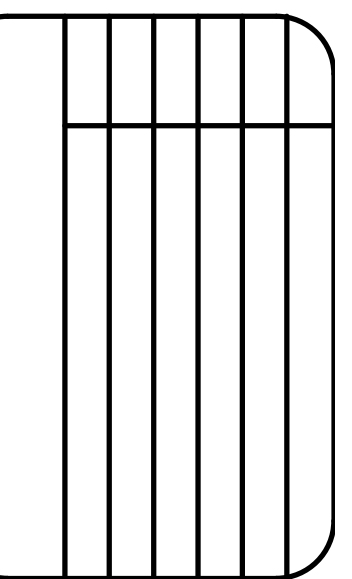
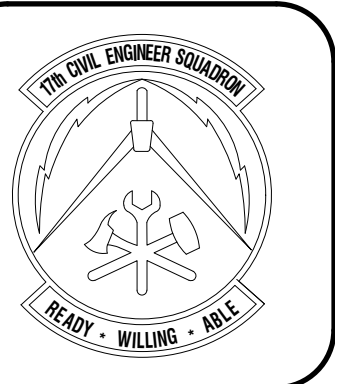

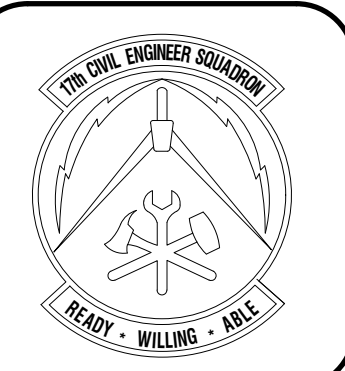

GENERAL DEMOLITION NOTES:

1. REFERENCE SHEET M-001 FOR LEGENDS, SYMBOLS, ABBREVIATIONS AND FURTHER GENERAL NOTES.
2. NOT ALL EXISTING DUCTWORK IS SHOWN. DUCTWORK SHOWN IS THAT PERTAINING TO DEMOLITION / REMODEL. HVAC FACILITIES NOT SHOWN SHALL REMAIN IN SERVICE AND REMAIN UNTOUCHED.
3. PRIOR TO BIDDING, THE CONTRACTOR SHALL FIELD VERIFY EXISTING CONDITIONS INCLUDING: EXACT LOCATIONS, SIZES AND QUANTITIES OF ITEMS WHICH ARE TO BE REMOVED, RELOCATED, AND/OR ADDED. SUBMITTAL OF A BID MUST SIGNIFY WILLINGNESS TO COMPLY WITH THE CONTRACTING OFFICER'S REQUIREMENTS; THE DESIGN AND SPECIFICATIONS; AND ACCEPTANCE OF ON-SITE CONDITIONS AS THEY EXIST.
4. FACILITIES NOT INDICATED OR NOT INDICATED TO BE REMOVED MUST REMAIN IN SERVICE EXCEPT:
 - 4.1. FACILITIES IN WALLS AND PARTITIONS BEING REMOVED MUST BE REMOVED.
 - 4.2. FACILITIES WHICH INTERFERE WITH THE INSTALLATION OF NEW PARTITIONS MUST BE RELOCATED AS REQUIRED TO ACCOMMODATE THE NEW PARTITIONING.
5. VERIFY ALL EXISTING PIPE SIZES BEFORE REMOVAL.
6. PERFORM ALL DEMOLITION IN ACCORDANCE WITH SPECIFICATIONS AND COORDINATE WITH PHASING PLAN.
7. SECURE ALL OPENINGS THROUGH WALLS, ROOFS, AND FLOORS FROM WEATHER DURING CONSTRUCTION. SECURE OPENINGS THROUGH ROOFS AND FLOORS WITH APPROPRIATE FALL PROTECTION MEASURES PER OSHA REQUIREMENTS.
8. COVER ALL DUCTWORK OPENINGS DURING CONSTRUCTION TO PREVENT MIGRATION OF DUST. INSTALL CONSTRUCTION FILTERS AT ALL RETURN OPENINGS OF ALL EQUIPMENT DURING CONSTRUCTION AND REPLACE AS REQUIRED TO PREVENT MIGRATION OF DUST.
9. PROVIDE DUST BARRIERS TO CRITICAL EQUIPMENT AREAS.
10. WHERE DEMOLITION WORK REQUIRES WORK IN HALLWAY: THE CONTRACTOR SHALL BE RESPONSIBLE FOR REMOVING THE MINIMUM CEILING TILES REQUIRED TO PERFORM WORK AND STORING TEMPORARILY UNTIL DEMOLITION IS COMPLETE, UPON WHICH THE CONTRACTOR SHALL REINSTALL SUCH CEILING TILES. WHERE DEMO WORK INSIDE OF CORRIDOR REQUIRES DEMOLITION OF GYP. BD. CEILINGS, THE CONTRACTOR SHALL BE RESPONSIBLE FOR CUTTING AND REMOVING THE MINIMUM AMOUNT OF AREA REQUIRED TO PERFORM WORK AND PROVIDING NEW GYP. BD. OF SIMILAR TYPE AND THICKNESS UPON COMPLETION OF DEMO WORK. UPON COMPLETION OF DEMOLITION CONTRACTOR SHALL PATCH, REPAIR, TAPE, AND FLOAT SEAMS TO MATCH EXISTING.
11. WHERE DEMOLITION WORK REQUIRES WORK IN FITNESS AREAS: THE CONTRACTOR SHALL BE RESPONSIBLE FOR REMOVING THE MINIMUM CEILING TILES REQUIRED TO PERFORM WORK AND STORING TEMPORARILY UNTIL DEMOLITION IS COMPLETE. THE GOVERNMENT WILL BE RESPONSIBLE FOR REMOVING FITNESS MACHINES AND EQUIPMENT PRIOR TO START OF CONTRACTOR WORK, AND WILL REINSTALL MACHINES AND EQUIPMENT UPON COMPLETION OF WORK.

KEYNOTES ⓧ

1. CONTRACTOR SHALL DEMOLISH EXISTING SUPPLY AND RETURN AIR DUCT GRILLS, BRANCHES, INSULATION, AND CAP DUCTWORK AT MAIN TRUNK.
2. CONTRACTOR SHALL DEMOLISH EXISTING THERMOSTAT INCLUDING WIRING, DEVICES, CONDUIT, AND CIRCUIT.

LEGEND

--- DEMO

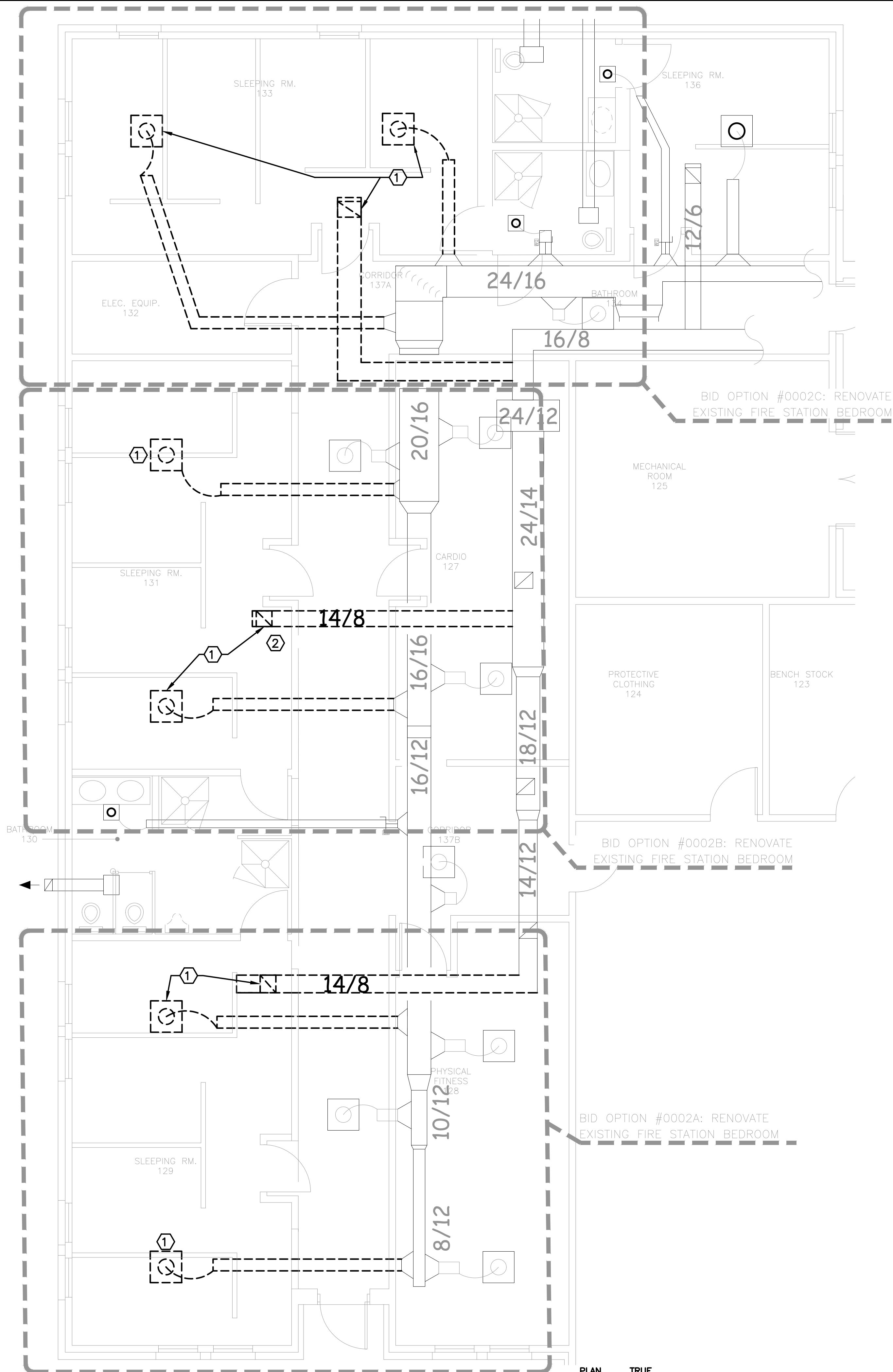

1 EXISTING BUILDING HVAC DEMOLITION PLAN
SCALE: 1/8"=1'-0"

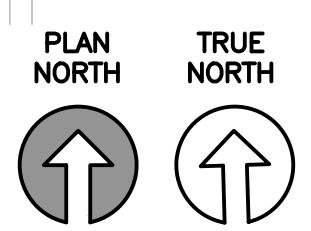

PROJECT TITLE
FIRE STATION ADD/ALTER, B3321
PROJECT NO. 1039839
17th TRAINING WING
GOODFELLOW AIR FORCE BASE, TEXAS

Project Number:	1039839
SHEET TITLE	HVAC DEMO - BID OPTIONS
Date:	SEP 2023

SEQ.	SHEET	OF
32	MD-101	50

GENERAL NOTES:

1. REFERENCE SHEET M-001 FOR LEGEND, SYMBOLS, ABBREVIATIONS AND FURTHER GENERAL NOTES.

KEYNOTES AS NOTATED BY:



1. FURNISH AND INSTALL AIR TERMINAL UNIT, CONTROLS, AND APPURTENANCES (REF. 1/M-501).
2. FURNISH AND INSTALL A BACNET COMPATIBLE THERMOSTAT.
3. FURNISH AND INSTALL A NEW EQUIPMENT PAD WITH 4" OF GRAVEL BASE BENEATH THE FOOTPRINT OF THE PAD. THE NEW EQUIPMENT PAD SHALL BE 5 1/2" THICK, 3,000 PSI CONCRETE WITH #4 REINFORCEMENT BARS ON 10" CENTERS EACH WAY. EXTEND THE PAD 4" BEYOND THE EDGES OF THE EQUIPMENT CURB. CHAMFER OR RADIUS THE TOP EDGES 1/2" X 1/2".
4. FURNISH AND INSTALL A DEDICATED OUTDOOR AIR SYSTEM UNIT, PLENUM CURB, CONTROLS AND APPURTENANCES. COORDINATE THE INSTALLATION OF THE DUCT SMOKE DETECTOR SERVING DOAS-1 WITH THE FIRE ALARM INSTALLER.
5. FURNISH AND INSTALL A BAROMETRIC RELIEF DAMPER AND TERMINATE THE RELIEF AIR DUCT WITH A WEATHERHOOD WITH AN INSECT SCREEN.
6. FURNISH AND INSTALL A 2" HUB DRAIN AND DRY WELL. ROUTE CONDENSATE PIPING OVER THE HUB DRAIN, TURN DOWN AND TERMINATE WITH AN AIR GAP. FOR MORE INFORMATION REFERENCE DETAIL 2/M-502.
7. FURNISH AND INSTALL A DX UNIT AND APPURTENANCES (REF. 1/M-502). FURNISH AND INSTALL A CONTROL CIRCUIT AND REFRIGERANT PIPING FROM THE OUTDOOR UNIT TO THE INDOOR FAN COIL UNIT. SIZE AND INSTALL THE REFRIGERANT PIPING IN ACCORDANCE WITH THE MANUFACTURER'S RECOMMENDATIONS. THE CONNECTION FROM THE OUTDOOR UNIT TO THE INDOOR FAN COIL UNIT SHALL BE ROUTED IN LIQUID TIGHT FLEXIBLE CONDUIT.
8. ROUTE THE REFRIGERANT PIPING AND CONTROL CIRCUIT DOWN IN THE WALL TO 6" AFF. SLEEVE THE EXTERIOR FACING AND ROUTE THE PIPING AND CONTROL CIRCUIT OUT THROUGH THE SLEEVE. SEAL CAULK THE ANNULAR SPACE BETWEEN THE PIPING/CONDUIT AND THE SLEEVE WEATHER TIGHT.
9. ROUTE INSULATED 3/4" PIPING FROM THE INTEGRAL CONDENSATE PUMP UP TO ABOVE THE CEILING AND CONNECT TO THE GRAVITY SLOPED CONDENSATE PIPING.
10. ROUTE THE CONDENSATE DRAIN DOWN WITHIN THE WALL, PENETRATE OUTSIDE, TURN DOWN AND TERMINATE WITH A 2" AIR GAP.
11. FURNISH AND INSTALL A CEILING MOUNTED EXHAUST FAN, CONTROLS AND APPURTENANCES. THE EXHAUST FAN SHALL BE SUSPENDED AND SUPPORTED FROM THE STRUCTURE ABOVE. ROUTE EXHAUST DUCTWORK FROM THE UNITS DISCHARGE CONNECTION THROUGH A ROOF CURB TO A ROOF JACK TRANSITION AND CONNECT. THE ROOF CURB SHALL BE FABRICATED TO ACCOUNT FOR THE ROOF PITCH SUCH THAT THE ROOF JACK IS INSTALLED LEVEL.
12. FURNISH AND INSTALL A SUSPENDED ELECTRIC UNIT HEATER WITH INTEGRAL THERMOSTAT AND APPURTENANCES. THE HEATER SHALL BE SEQUENCED SUCH THAT THE TEMPERATURE OF THE ROOM DOES NOT FALL BELOW 45 DEG F (ADJ).

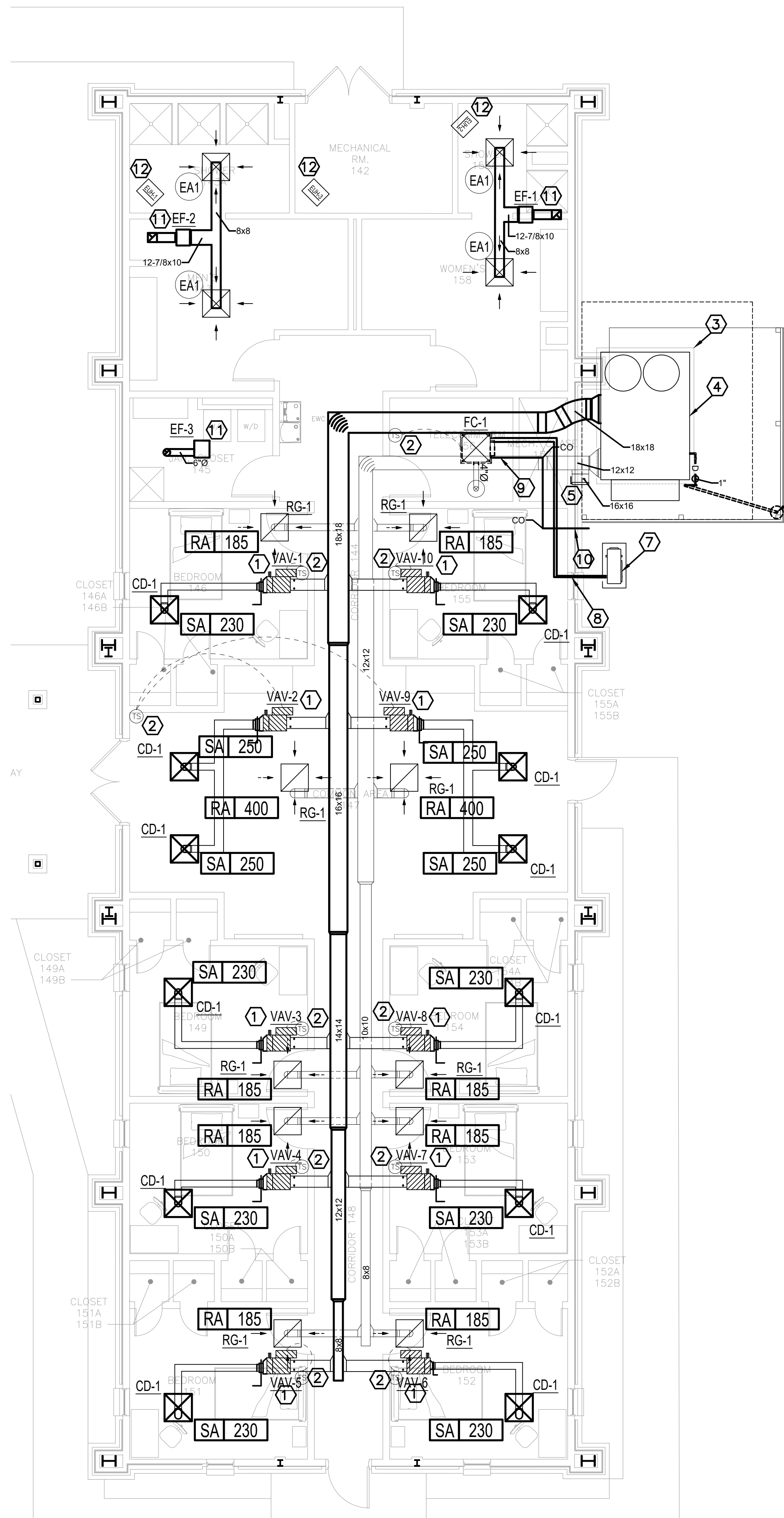

1 HVAC PLAN - ADDITION
 3/8" = 1' - 0"

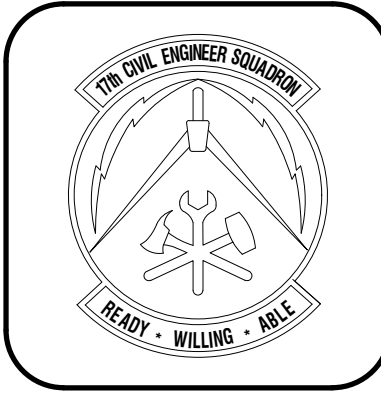
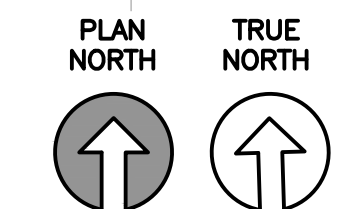

--	--	--	--	--	--

Designed by JRM/MLLA	Drawn by JRM/MLLA	Reviewed by RTI/JH	Submitted by PCBS
-------------------------	----------------------	-----------------------	----------------------

PROJECT TITLE
FIRE STATION ADD/ALTER, B3321
PROJECT NO. 1039839
17th TRAINING WING
GOODFELLOW AIR FORCE BASE, TEXAS

Project Number: 1039839
SHEET TITLE HVAC PLAN - NEW ADDITION
Date: SEP 2023

SEQ.	SHEET	OF
33	M-101	50

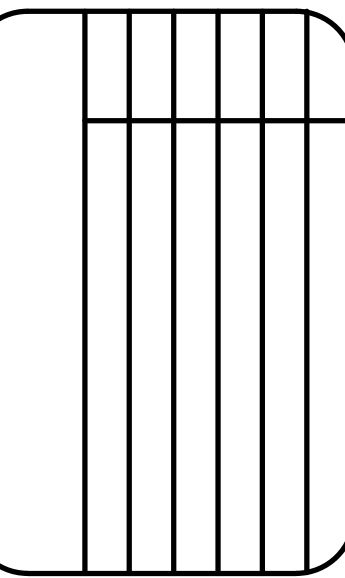
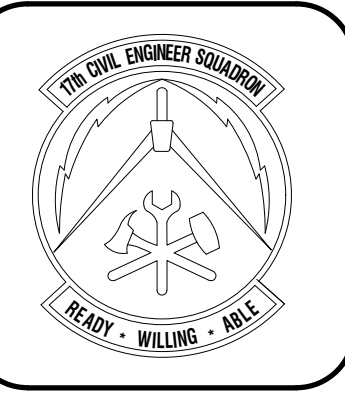

Designed by
JH/MLA

Drawn by
JH/MLA

Reviewed by
RT/JH

Submitted by
PCES

PROJECT TITLE

FIRE STATION ADD/ALTER, B3321
PROJECT NO. 1039839
17th TRAINING WING
GOODFELLOW AIR FORCE BASE, TEXAS

Project Number:
1039839

SHEET TITLE
HVAC PLAN - BID
OPTIONS

Date:
SEP 2023

SEQ.	SHEET	OF
34	M-102	50

GENERAL NOTES:

1. REFERENCE SHEET M-101 FOR LEGEND, SYMBOLS, ABBREVIATIONS, AND FURTHER GENERAL NOTES.
2. MINOR ALTERATION WORK INCLUDING: CUT, PATCH, PAINT AND OTHERWISE FINISH SURFACES SHALL MATCH ADJACENT SURFACES.
3. REGARDLESS OF WHICH BID OPTION IS AWARDED, THE CONTRACTOR WILL BE RESPONSIBLE FOR PROVIDING (1) HEAT PUMP, CONCRETE PAD, CORRESPONDING PIPING FOR A COMPLETE AND FUNCTIONAL SYSTEM.

KEYNOTES: (3)

1. FURNISH AND INSTALL A NEW EQUIPMENT PAD WITH 4" OF GRAVEL BASE BENEATH THE FOOTPRINT OF THE PAD. THE NEW EQUIPMENT PAD SHALL BE 5-1/2" THICK, 3000 PSI CONCRETE WITH #4 REINFORCEMENT BARS ON 10" CENTERS EACH WAY. EXTEND THE PAD 4" BEYOND THE EDGES OF THE EQUIPMENT CURB. CHAMFER OR RADIUS THE TOP EDGES 1/2" X 1/2".
2. FURNISH AND INSTALL A HEAT PUMP AND PERTINENT APPURTENANCES (REF 7/M-501), FURNISH AND INSTALL A CONTROL CIRCUIT AND REFRIGERANT PIPING FROM THE HEAT PUMP UNIT TO EACH INDOOR UNIT (6 TOTAL). SIZE AND INSTALL THE REFRIGERANT PIPING IN ACCORDANCE WITH THE MANUFACTURER'S RECOMMENDATIONS. THE CONNECTION TO THE HEAT PUMP UNIT SHALL BE ROUTED IN LIQUID TIGHT FLEXIBLE CONDUIT.
3. FURNISH AND INSTALL A INDOOR UNIT AND PERTINENT APPURTENANCES IN ACCORDANCE WITH MFR INSTRUCTIONS.
4. FURNISH AND INSTALL A TEMPERATURE SENSOR.
5. ROUTE THE REFRIGERANT PIPING AND CONTROL CIRCUIT DOWN IN THE WALL TO 6" AFF. SLEEVE THE EXTERIOR FACING AND ROUTE THE PIPING AND CONTROL CIRCUIT OUT THROUGH THE SLEEVE. SEAL CAULK THE ANNULAR SPACE BETWEEN THE PIPING/CONDUIT AND SLEEVE WEATHER TIGHT.

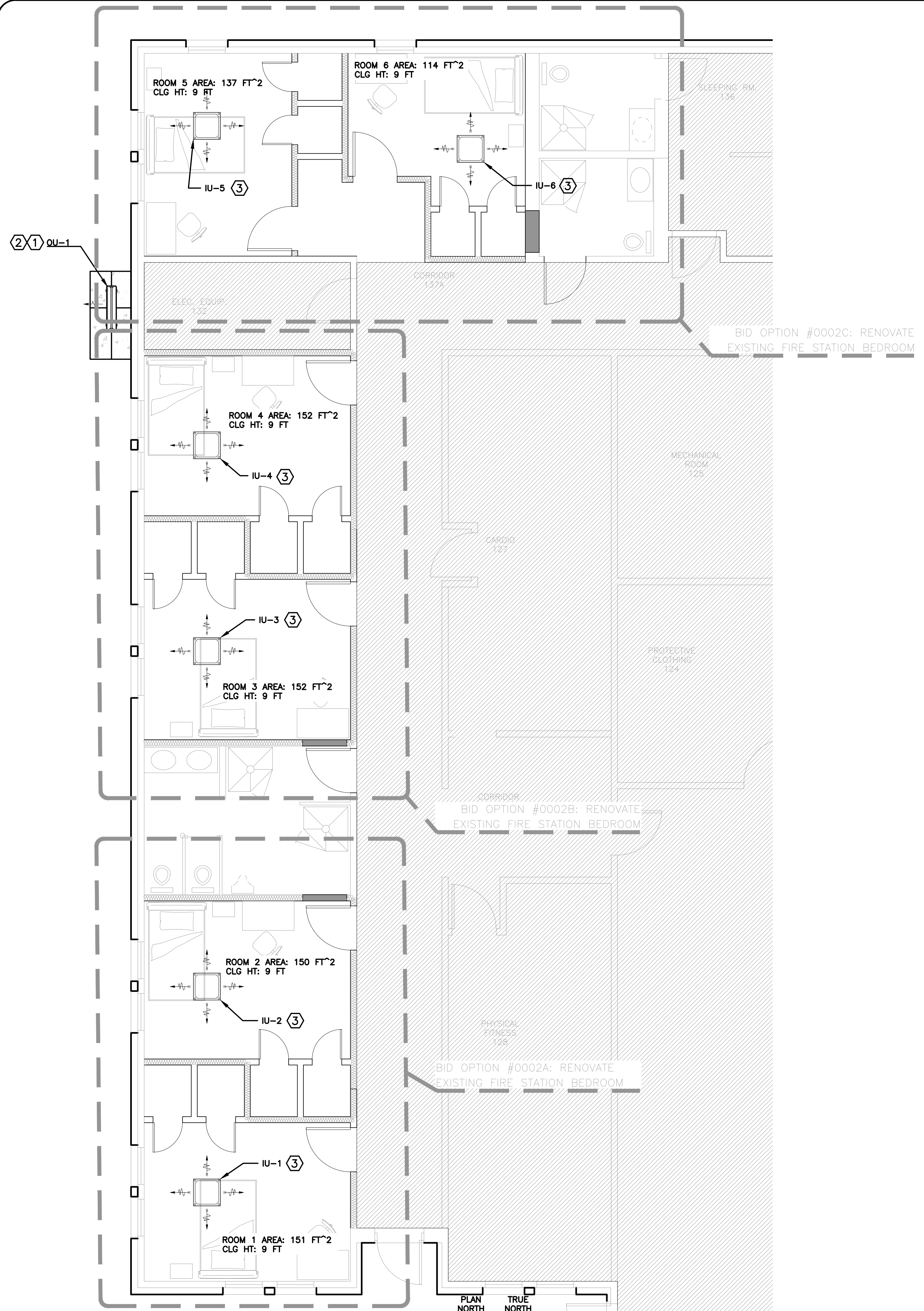

1 HVAC PLAN - BID OPTIONS
SCALE: 1/4"=1'-0"

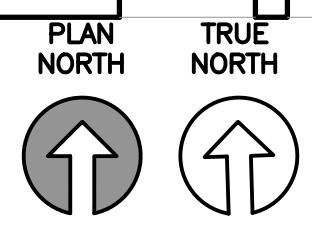

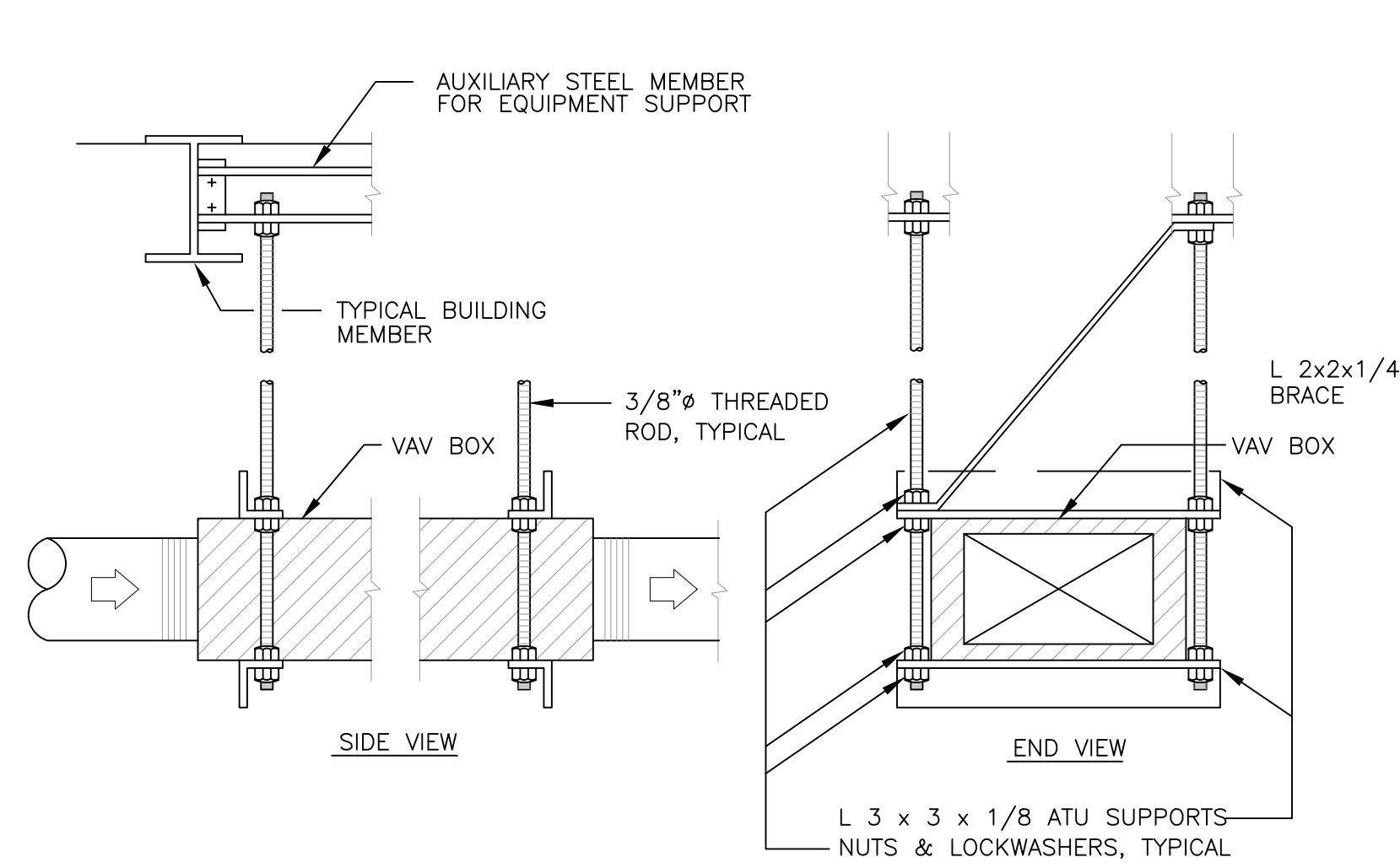

1 VAV BOX MOUNTING DETAIL
NTS

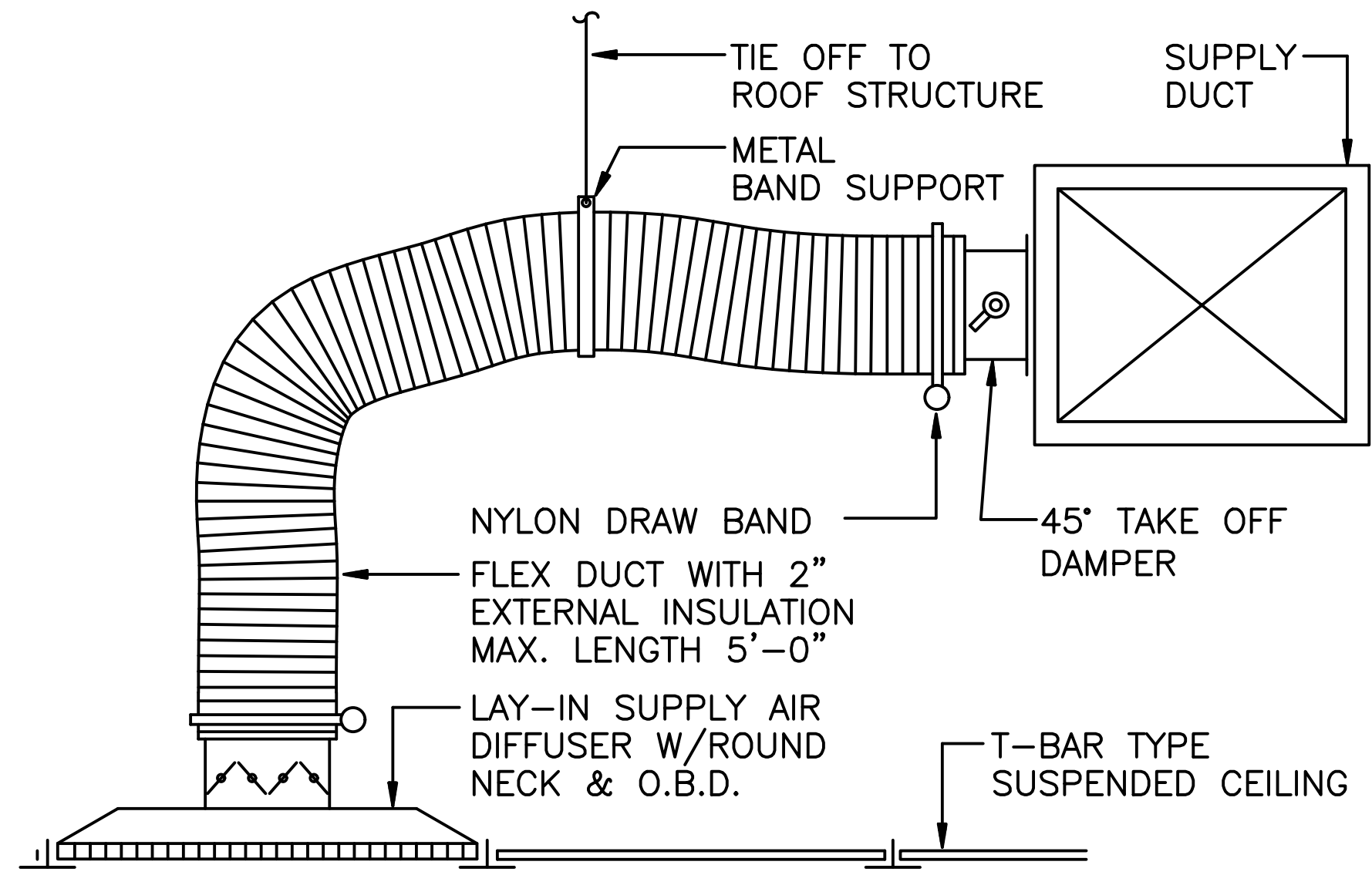

2 SUPPLY AIR DIFFUSER DETAIL
NTS

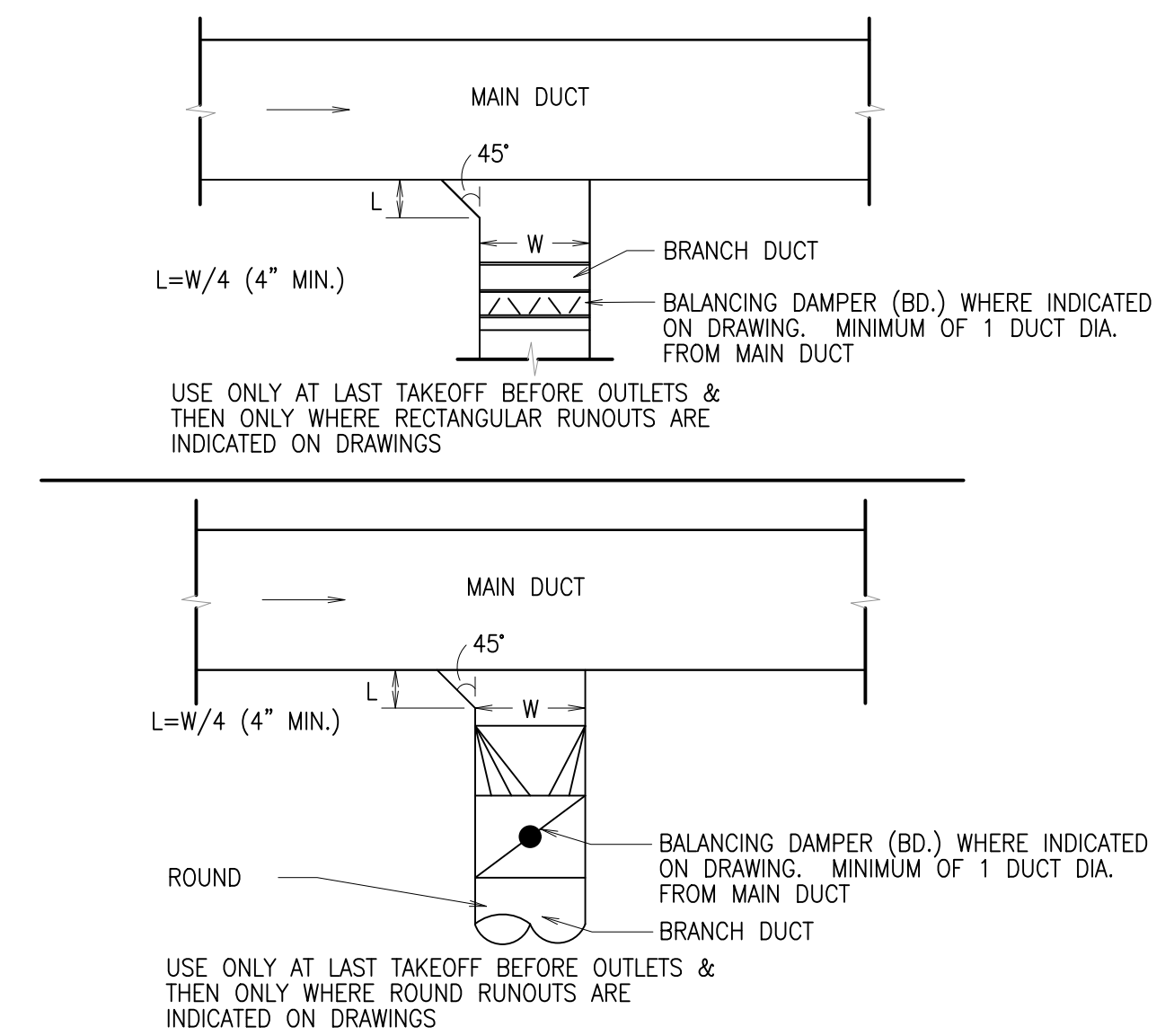

3 TYP. DUCT BRANCH CONNECTION DETAIL
NTS

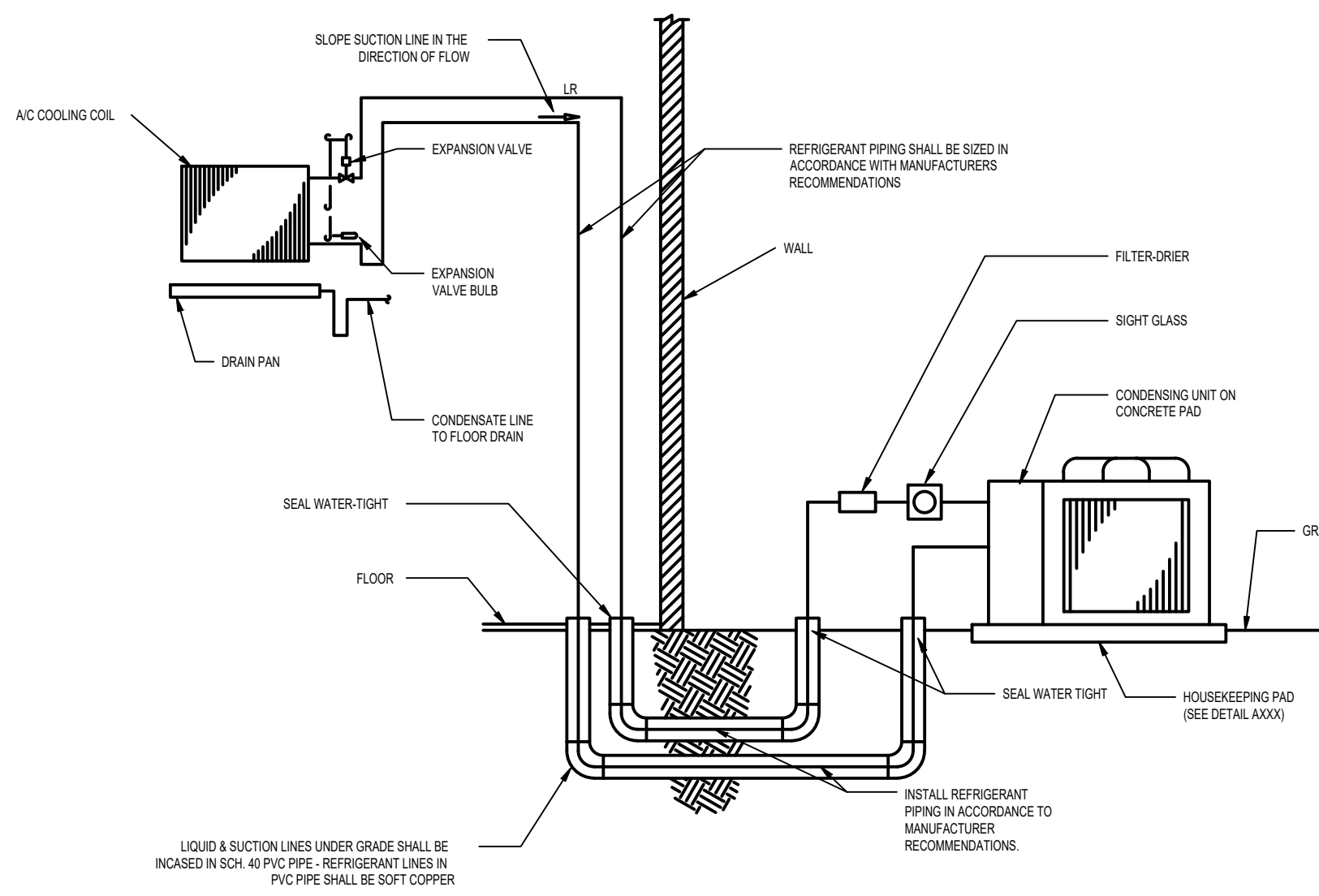

4 REFRIGERANT PIPING DIAGRAM
NTS

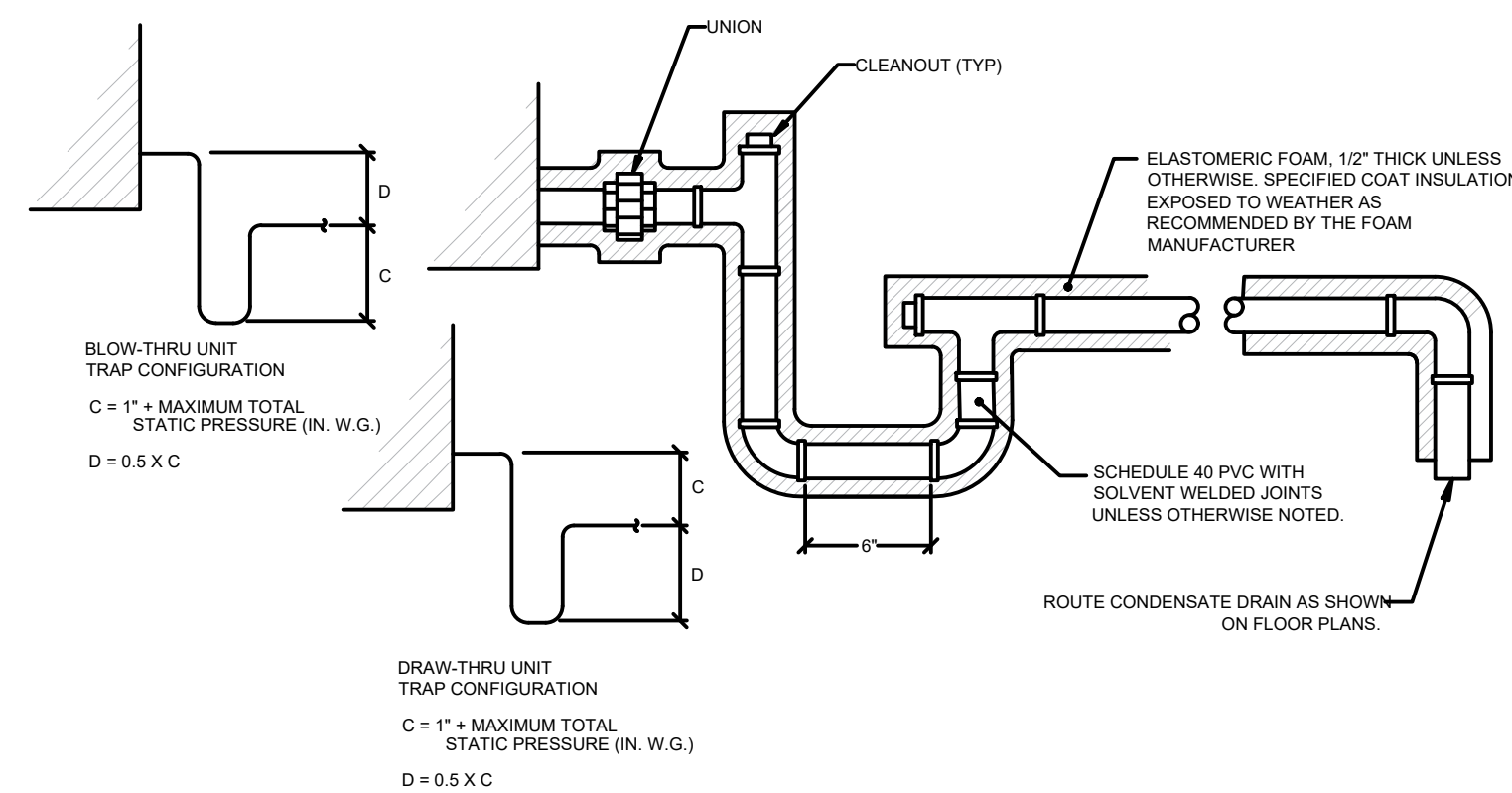

5 CONDENSATE TRAP INSTALLATION DETAIL
NTS

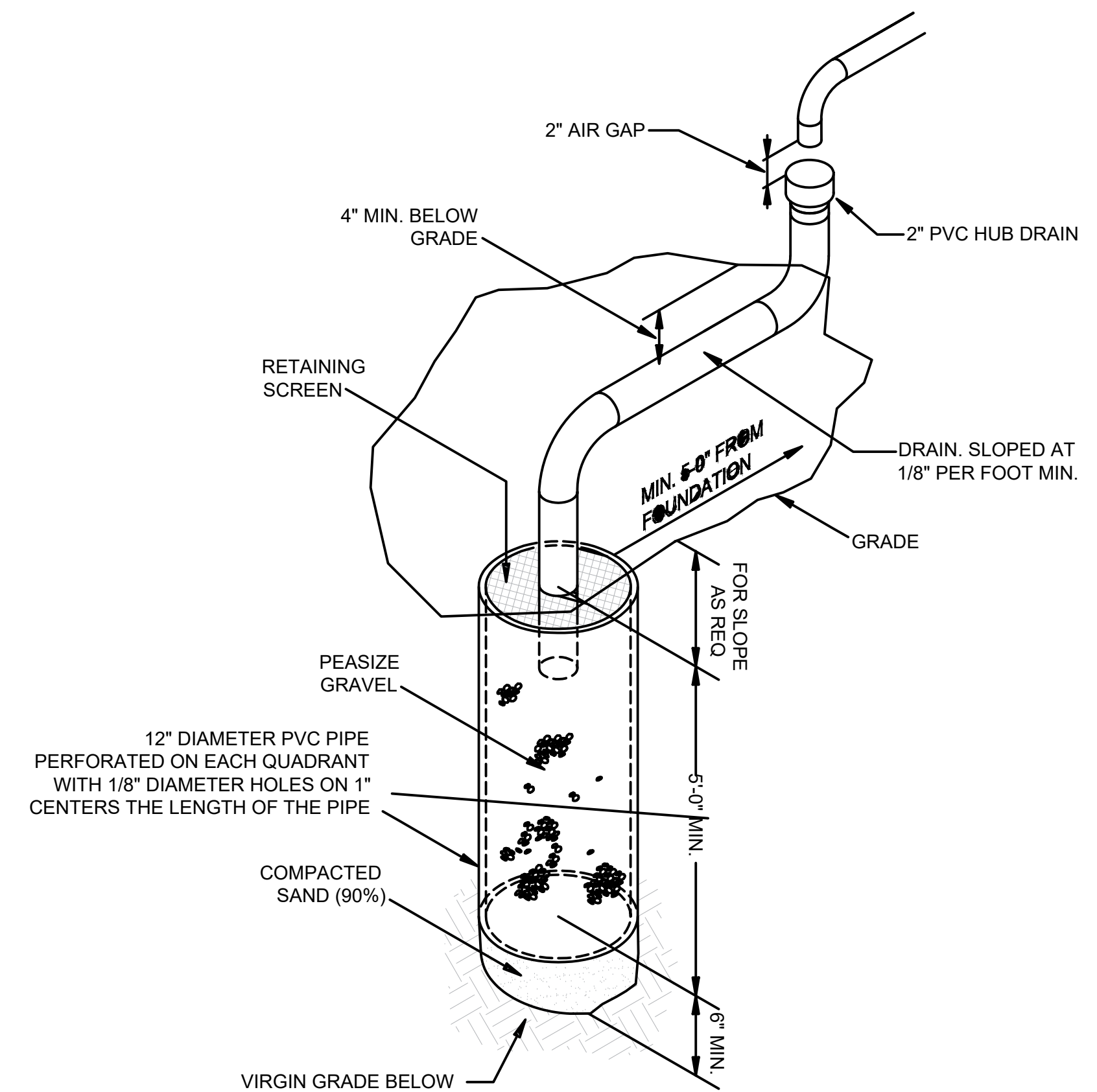

6 DRY WELL DETAIL
NTS

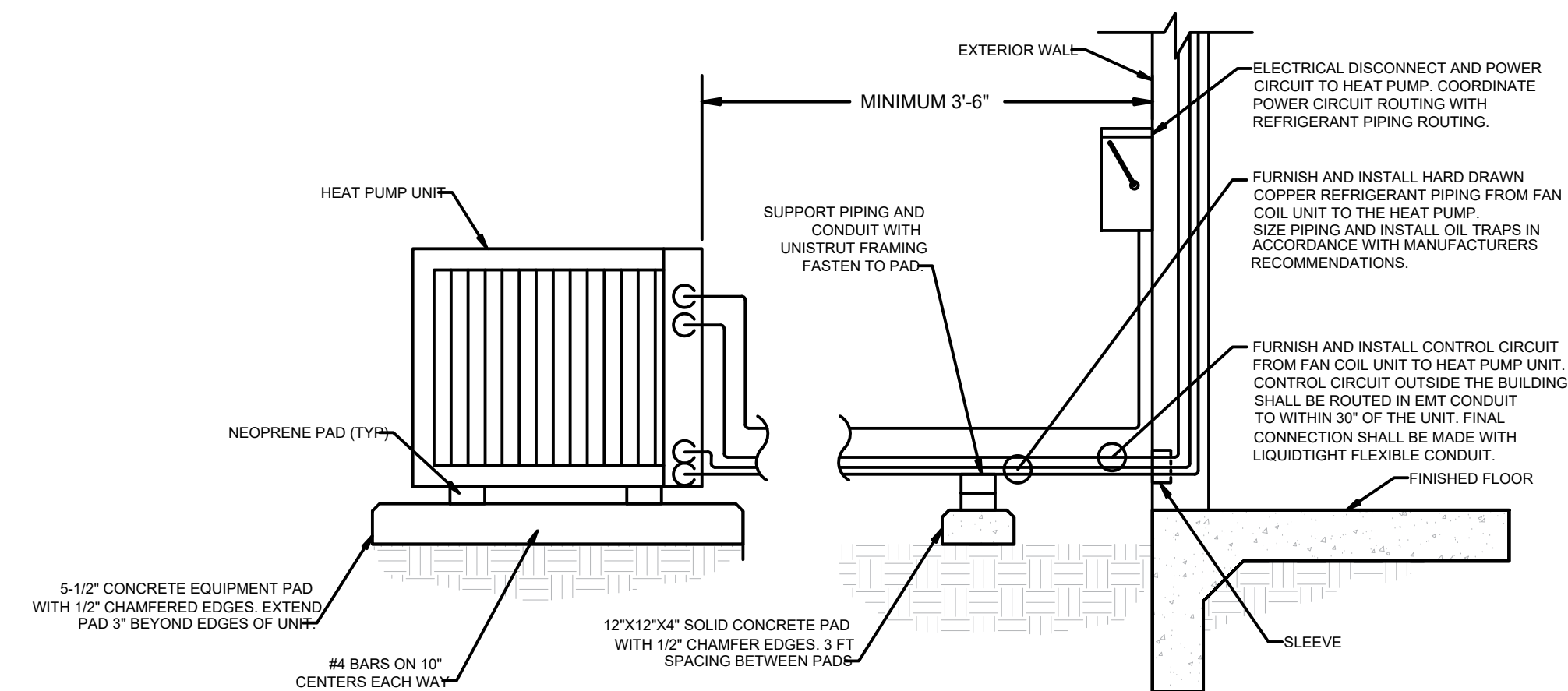

7 HEAT PUMP INSTALLATION DETAIL
NTS

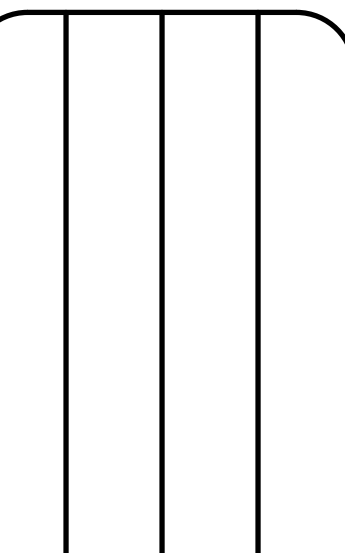
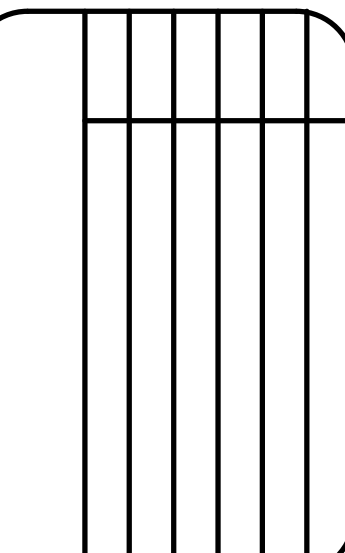
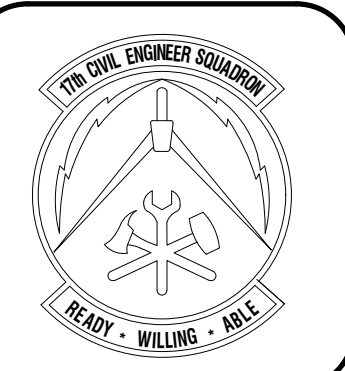

Designed by:
JRM/LLA
Drawn by:
JRM/LLA
Reviewed by:
RTJ/JH
Submitted by:
PCBS

PROJECT TITLE
FIRE STATION ADD/ALTER, B3321
PROJECT NO. 1039839
17th TRAINING WING
GOODFELLOW AIR FORCE BASE, TEXAS

Project Number:
1039839
SHEET TITLE
HMC DETAILS
Date:
SEP 2023

SEQ. SHEET OF
35 M-501 50

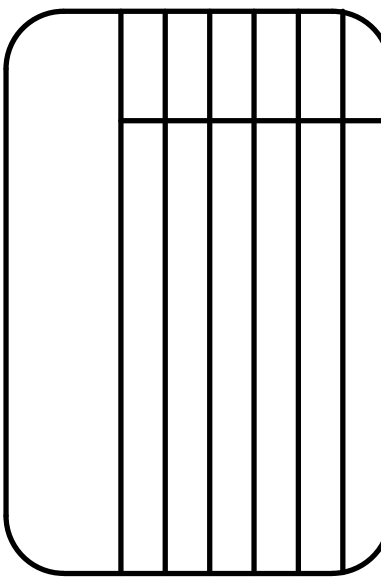
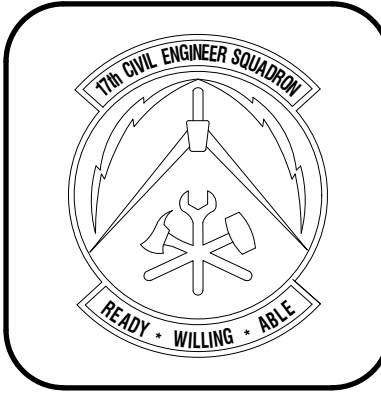

Designed by:
JRM/MLA
Drawn by:
JRM/MLA
Reviewed by:
RTI/AH
Submitted by:
PCES

PROJECT TITLE
**FIRE STATION ADD/ALTER, B3321
PROJECT NO. 1039839
17th TRAINING WING
GOODFELLOW AIR FORCE BASE, TEXAS**

Project Number:
1039839
SHEET TITLE
HVAC SCHEDULES
Date:
SEP 2023

SEQ. SHEET OF
36 **M-601** 50

MARK	NOMINAL COOLING CAPACITY (BTUH)	NOMINAL HEATING CAPACITY (BTUH)	SUPPLY AIR FLOW (CFM)	OUTSIDE AIR (CFM)	EFFICIENCY RATING (SEER)	ELECTRICAL								BASIS OF DESIGN	NOTES
						FAN COIL UNIT				HEAT PUMP UNIT					
						MARK	VOLTS/PHASE/HZ	MCA	MAX FUSE	MARK	VOLTS/PHASE/HZ	MCA	MAX FUSE		
OU-1	60000	66000	-	4850	20.5	-	-	-	-	OU-1	208-230/1/60	36.3	40	6	1,2,3,4,5
IU-1	7500	8500	220/270/320	-	-	IU-1	208-230/1/60	0.5	15	-	-	-	-	7	5
IU-2	7500	8500	220/270/320	-	-	IU-2	208-230/1/60	0.5	15	-	-	-	-	7	5
IU-3	7500	8500	220/270/320	-	-	IU-3	208-230/1/60	0.5	15	-	-	-	-	7	5
IU-4	7500	8500	220/270/320	-	-	IU-4	208-230/1/60	0.5	15	-	-	-	-	7	5
IU-5	7500	8500	220/270/320	-	-	IU-5	208-230/1/60	0.5	15	-	-	-	-	7	5
IU-6	7500	8500	220/270/320	-	-	IU-6	208-230/1/60	0.5	15	-	-	-	-	7	5

NOTES:
 1. FURNISH AND INSTALL THE HEAT PUMP WITH CONDENSER COIL (HAIL) GUARD AND OPTIONAL WIND BAFFLE FOR EXTENDED OPERATING RANGE.
 2. FURNISH AND INSTALL THE UNIT WITH SINGLE POINT OF ELECTRICAL CONNECTION.
 3. FURNISH AND INSTALL THE UNIT WITH BANET CAPATIBLE THERMOSTAT.
 4. FURNISH AND INSTALL THE UNIT WITH A LOW AMBIENT STARTUP KIT.
 5. THE SYSTEM SHALL BE MANUFACTURED BY TRANE, CARRIER, BRYANT, OR APPROVED EQUAL.
 6. TOSHIBA/CARRIER MCY-MAP0607HS-UL-HEAT PUMP
 7. TOSHIBA/CARRIER MMU-AP0071MH2UL-COMPACY 4-WAY CASSETTE

AIR DEVICE SCHEDULE										
MARK	TYPE	NECK SIZE (IN)	MODULE SIZE (IN)	MATERIAL	MAX. CFM	THROW AT 100 FEET	TOTAL STATIC PRESSURE (IN WG)	NOISE CRITERIA RATING (NC)	BASIS OF DESIGN:	NOTES
CD1	SUPPLY CEILING DIFFUSER	6 Ø	24X24	ALUMINUM	275	5	0.099	25-30	TITUS OMNI	1
RG1	RETURN CEILING GRILLE	22X10	24X24	ALUMINUM	700	-	0.06	18	TITUS 350 FL	1
EG1	EXHAUST CEILING GRILLE	8X8	24X24	ALUMINUM	415	-	0.013	18	GREENHECK XG-CC5	1

NOTES:
 1. FURNISH AND INSTALL AIR DEVICE WITH LAY-IN BORDER FRAME FOR LAY-IN CEILING AND SURFACE MOUNTING FRAME FOR ALL OTHER APPLICATIONS.

AIR TERMINAL UNIT SCHEDULE										
MARK	TYPE	CFM			HEATING			ELECTRICAL		
		MAX	MIN	CFM	MIN. KW (NOTE 3)	NOMINAL KW (NOTE 3)	VOLTAGE /PHASE	MCA	MOC	
VAV-1	SINGLE DUCT W/HEATING COIL (BEDROOM 146)	230	150	150	2.2	2.5	208/3	8.7	15	
VAV-2	SINGLE DUCT W/HEATING COIL (COMMON AREA 147W)	500	300	300	4.3	4.5	208/3	15.6	20	
VAV-3	SINGLE DUCT W/HEATING COIL (BEDROOM 149)	230	150	150	2.2	2.5	208/3	8.7	15	
VAV-4	SINGLE DUCT W/HEATING COIL (BEDROOM 150)	230	150	150	2.2	2.5	208/3	8.7	15	
VAV-5	SINGLE DUCT W/HEATING COIL (BEDROOM 151)	230	150	150	2.2	2.5	208/3	8.7	15	
VAV-6	SINGLE DUCT W/HEATING COIL (BEDROOM 152)	230	150	150	2.2	2.5	208/3	8.7	15	
VAV-7	SINGLE DUCT W/HEATING COIL (BEDROOM 153)	230	150	150	2.2	2.5	208/3	8.7	15	
VAV-8	SINGLE DUCT W/HEATING COIL (BEDROOM 154)	230	150	150	2.2	2.5	208/3	8.7	15	
VAV-9	SINGLE DUCT W/HEATING COIL (COMMON AREA 147E)	500	300	300	4.3	4.5	208/3	15.6	20	
VAV-10	SINGLE DUCT W/HEATING COIL (BEDROOM 155)	230	150	150	2.2	2.5	208/3	8.7	15	

NOTES APPLY TO ALL VAV AIR TERMINAL UNITS:
 1. INLET STATIC = 1.5" W.C.; MAX UNIT PRESSURE DROP = 0.5" W.C.; MAX NC = 25
 2. PROVIDE DUCT TRANSITION AT UNIT WHERE UNIT INLET SIZE AND DUCT RUNOUT SIZE ARE DIFFERENT.
 3. PROVIDE ELECTRIC REHEAT FOR VAVS

PACKAGED UNIT SCHEDULE																
MARK	OUTSIDE AIR FLOW RATE (CFM)	EXTERNAL STATIC PRESSURE AT MAXIMUM AIR FLOW (W.G.)	SPACE SHR	MIN. COOLING SUPPLY AIR FLOW RATE	MAX COOLING SUPPLY AIR FLOW RATE (CFM)	COOLING					TOTAL CAPACITY (MBH) AT 97.8 (F) AMBIENT	ELECTRICAL			NOTES	
						ENTERING AIR DB TEMP. (F)	ENTERING AIR (WB) TEMP. (F)	LEAVING AIR DB TEMP (F)	LEAVING AIR WB TEMP. (F)	SENSIBLE CAPACITY (MBH)		LATENT CAPACITY (MBH)	VOLTS/PHASE	MCA		MOC
PAC-1	375	2"	0.916	-	2840	74.3	60.3	52.6	51.3	63.7	5.9	69.6	208/3	74.1	90	1,2,3,4,5,6,7,8

NOTES:
 1. FURNISH AND INSTALL PACKAGED UNIT WITH A METAL CONDENSER COIL (HAIL) GUARD.
 2. FURNISH AND INSTALL PACKAGED UNIT WITH A FILTER RACK AND 2" THICK MERV 13 FILTERS.
 3. FURNISH AND INSTALL THE UNIT WITH A SINGLE POINT ELECTRICAL CONNECTION AND NON-CORROSIVE DRAIN PAN.
 4. THE CONDENSER SETION SHALL BE SELECTED BASED ON AN OUTDOOR AMBIENT AIR TEMPERATURE OF 105 F AT THE COOLING CONDITIONS.
 5. FURNISH AND INSTALL UNIT WITH AN ECONOMIZER SEQUENCE, DAMPERS, RELIEF DAMPER, CONTROLS, AND ACCESSORIES.
 6. THE PACKAGE UNIT SHALL BE A TRANE "HORIZON" MODEL OR APPROVED EQUAL.
 7. SYSTEM SHALL INCLUDE LOW AMBIENT CONTROL.
 8. SYSTEM SHALL INCLUDE SOUND ATTENUATION PACKAGE

FAN COIL UNIT SCHEDULE													
MARK	NOMINAL COOLING CAPACITY (BTUH)	SUPPLY AIR FLOW (CFM)	OUTSIDE AIR (CFM)	EFFICIENCY RATING (SEER)	FAN COIL UNIT				HEAT PUMP UNIT				NOTES
					MARK	VOLTS/P HASE/HZ	MCA	MAX FUSE	MARK	VOLTS/PHASE	MCA	MAX FUSE	
FC/HP-1	18000	450	5	17	FC-1	POWERED BY OUTDOOR UNIT			HP-1	208-230/1	18.3	20	1,2,3,4,5,6

NOTES:
 1. FURNISH AND INSTALL THE HEAT PUMP WITH CONDENSER COIL (HAIL) GUARD AND OPTIONAL WIND BAFFLE FOR EXTENDED OPERATING RANGE.
 2. FURNISH AND INSTALL THE UNIT WITH SINGLE POINT OF ELECTRICAL CONNECTION.
 3. FURNISH AND INSTALL THE UNIT WITH BACNET COMPATIBLE THERMOSTAT.
 4. FURNISH AND INSTALL THE UNIT WITH A LOW AMBIENT STARTUP KIT.
 5. FURNISH AND INSTALL THE FC UNIT WITH AN INTERGRAL CONDENSATE PUMP.
 6. THE SYSTEM SHALL BE MANUFACTURED BY TRANE, CARRIER, BRYANT, OR APPROVED EQUAL.

FAN SCHEDULE										
MARK	Description	CFM	EXTERNAL STATIC PRESSURE (WG)	SOUND (SONES)	FAN			ELECTRICAL	REFERENCE SELECTION: GREENHECK	NOTES
					RPM	WATTS	DRIVE			
EF-1	144 MALE	290	0.25	1.3	1095	73	DIRECT	115/1	CSP-A390	1,2,3
EF-2	157 FEMALE	240	0.25	1.3	964	48	DIRECT	115/1	CSP-A390	1,2,3
EF-3	146 JANITOR	80	0.25	0.9	796	80	DIRECT	115/1	SP-B110	1,2

NOTES:
 1. FURNISH AND INSTALL FAN WITH INTEGRAL BACKDRAFT DAMPER AND FAN SPEED CONTROLLER.
 2. FURNISH AND INSTALL FEMP OR ENERGY STAR COMPLIANT FAN.
 3. FURNISH AND INSTALL FAN TO BE CONTROLLED TO OPERATE WITH THE LIGHTIN OCCUPANCY OR VACANCY SENSOR + 15 MINUTES.

ELECTRIC UNIT HEATER SCHEDULE			
MARK	HEATER SIZE	ELECTRICAL VOLTS/PHASE	NOTES
EUH-1	4 KW	208/3	1,2
EUH-2	4 KW	208/3	1,2
EUH-3	3 KW	208/3	1,2

NOTES:
 1. FURNISH AND INSTALL AN ELECTRIC RESISTANCE HEATER WITH INTEGRAL
 2. MOUNT THE UNIT HEATER SUSPENDED FROM THE STRUCTURE

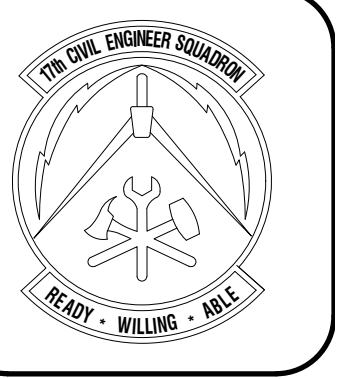

ELECTRIC STANDARD SYMBOLS AND ABBREVIATIONS (NOT ALL APPLY)

STANDARD SYMBOLS - POWER		STANDARD SYMBOLS - POWER		STANDARD SYMBOLS - LIGHTING		STANDARD SYMBOLS - COMM/DATA																																																																																																																																																																																																													
SYMBOL	DESCRIPTION	SYMBOL	DESCRIPTION	SYMBOL	DESCRIPTION	SYMBOL	DESCRIPTION																																																																																																																																																																																																												
	SINGLE RECEPTACLE , 125V, 30A, NEMA 5-30R		BALANCED MAGNETIC SWITCH		LED LIGHT , RECESSED, SURFACE OR PENDANT MOUNT (SEE FIXTURE SCHEDULE FOR MOUNTING TYPE)		DATA OUTLET , WALL MOUNT																																																																																																																																																																																																												
	DUPLEX RECEPTACLE , 125V, 20A, NEMA 5-20R		SAFETY SWITCH AND MOTOR CONTROLLER , COMBINATION, PROVIDE WITH ELECTRICAL LOCK-OUT PROVISIONS. MOUNT TOP AT 72" ABOVE FLOOR UNLESS NOTE OTHERWISE		LED LIGHT , SURFACE, PENDANT, OR RECESSED MOUNT, EMERGENCY (SEE FIXTURE SCHEDULE FOR MOUNTING TYPE)		DATA JACK , FLOOR MOUNT																																																																																																																																																																																																												
	DUPLEX RECEPTACLE , GFI, 125V, 20A, NEMA 5-20R		FUSED DISCONNECT , MOUNT TOP AT 72" ABOVE FLOOR UNLESS NOTE OTHERWISE		LED LIGHT , STRIP		COMBINATION DATA/TELEPHONE OUTLET , WALL MOUNT																																																																																																																																																																																																												
	DUAL DUPLEX RECEPTACLE , 125V, 15A, NEMA 5-15R		SAFETY SWITCH , MOUNT TOP AT 72" ABOVE FLOOR UNLESS NOTE OTHERWISE		LED LIGHT , STRIP, NIGHT LIGHT		COMBINATION DATA/TELEPHONE JACK , FLOOR MOUNT																																																																																																																																																																																																												
	DUPLEX RECEPTACLE , GFI, 125V, 15A, NEMA 5-15R		ENCLOSED BREAKER , MOUNT TOP AT 72" ABOVE FLOOR UNLESS NOTE OTHERWISE		LED LIGHT , STRIP, EMERGENCY		TELEPHONE OUTLET , WALL MOUNT																																																																																																																																																																																																												
	DUPLEX RECEPTACLE , 125V, 15A, NEMA 5-15R		SWITCH-MOTOR RATED , THERMAL OVERLOAD, FOR FRACTIONAL HORSEPOWER MOTORS		LED LIGHT , CEILING OR PENDANT		TELEPHONE JACK , FLOOR MOUNT																																																																																																																																																																																																												
	DUPLEX RECEPTACLE , CEILING SURFACE MOUNTED, 125V, 15A, NEMA 5-15R		CABLE TRAY		LED LIGHT , RECESSED		PA/AUDIO																																																																																																																																																																																																												
	DUAL DUPLEX RECEPTACLE , RAISED FLOOR MOUNT, 125V, 20A, NEMA 5-20R		ELECTRICAL PRIMARY , AERIAL		EXIT LIGHT , WALL MOUNT, SINGLE FACE, 90 MINUTE BATTERY PACK, R LETTER MEANS RECESSED		SPEAKER CEILING MOUNTED																																																																																																																																																																																																												
	RECEPTACLE , 20A, 125V, 2P/3W, LOCKING, NEMA REF XX-20R		ELECTRICAL PRIMARY , AERIAL, EXISTING		SWITCH , SINGLE POLE SINGLE THROW (SPST) SWITCH, SMALL LETTER INDICATES DEVICE SWITCHED		SPEAKER WALL MOUNTED																																																																																																																																																																																																												
	POWER POLE , RECESS MOUNT		ELECTRICAL PRIMARY , UNDERGROUND		SWITCH , DOUBLE POLE SINGLE THROW (DPST) SWITCH, SMALL LETTER INDICATES DEVICE SWITCHED (IF USED)		COMMUNICATION CABLE , UNDERGROUND, EXISTING																																																																																																																																																																																																												
	PLUG-IN STRIP , AS SPECIFIED ON PLANS		ELECTRICAL PRIMARY , UNDERGROUND, EXISTING		SWITCH , SINGLE POLE DOUBLE THROW (SPDT-3 POLE) SWITCH, SMALL LETTER INDICATES DEVICE SWITCHED (IF USED)		FIBER OPTIC CABLE																																																																																																																																																																																																												
	PANELBOARD , 240V OR 208V, RECESS MOUNT		ELECTRICAL SECONDARY , AERIAL		SWITCH , DOUBLE POLE DOUBLE THROW (DPDT-4 POLE) SWITCH, SMALL LETTER INDICATES DEVICE SWITCHED (IF USED)	ANNOTATIVE SYMBOLS																																																																																																																																																																																																													
	PANELBOARD , 240V OR 208V, SURFACE MOUNT		ELECTRICAL SECONDARY , AERIAL, EXISTING		SWITCH , SINGLE POLE, DIMMING TYPE SWITCH, SMALL LETTER INDICATES DEVICE SWITCHED (IF USED)		KEY NOTE X - DENOTES THE KEY NOTE NUMBER																																																																																																																																																																																																												
	PANELBOARD , 480V, RECESS MOUNT		ELECTRICAL SECONDARY , UNDERGROUND		SWITCH , EMERGENCY POWER OFF		CIRCUIT IDENTIFICATION XX - DENOTES FEEDER NUMBER/IDENTIFICATION																																																																																																																																																																																																												
	PANELBOARD , 480V, SURFACE MOUNT		ELECTRICAL SECONDARY , UNDERGROUND, EXISTING		SWITCH , SINGLE POLE, WEATHERPROOF SWITCH, SMALL LETTER INDICATES DEVICE SWITCHED (IF USED)	TITLE																																																																																																																																																																																																													
	FIRE ALARM CONTROL PANEL , SURFACE MOUNT		ELECTRICAL DUCTBANK		PHOTOCELL , HEAVY DUTY DIE CAST HOUSING, SPST, 120V OR 208/277V, 1800VA	NOT TO SCALE																																																																																																																																																																																																													
	JUNCTION BOX , SIZE FOR WIRE FILL OR AS SPECIFIED		CEILING FAN , RECESSED		OCCUPANCY SENSOR , CEILING MOUNT	DETAIL BUBBLE TITLE - INDICATES THE TITLE OF THE DETAIL SCALE - INDICATES THE SCALE OF THE DETAIL (IF APPLICABLE) X - DENOTES DETAIL NUMBER Y - DENOTES SHEET NUMBER Z - DENOTES REFERENCE SHEET NUMBER																																																																																																																																																																																																													
	JUNCTION BOX , FLOOR MOUNT		WATT-HOUR METER		HUMIDITY SENSOR , CEILING MOUNT	ABBREVIATIONS																																																																																																																																																																																																													
	GENERATOR , AS SPECIFIED ON PLANS		CONDUIT OR WIRE REPAIR ITEM	<table style="width: 100%; border-collapse: collapse;"> <tr> <td>A</td><td>AMPERE(S)</td> <td>F.C.O.</td><td>FLOOR CLEAN OUT</td> <td>N.T.S.</td><td>NOT TO SCALE</td> </tr> <tr> <td>A.C.</td><td>ABOVE COUNTER</td> <td>F.D.</td><td>FIRE DAMPER</td> <td>O</td><td>OXYGEN</td> </tr> <tr> <td>A/C</td><td>AIR CONDITIONED</td> <td>FLR</td><td>FLOOR</td> <td>O.A.</td><td>OUTSIDE AIR</td> </tr> <tr> <td>A.D.</td><td>ACCESS DOOR</td> <td>FPM</td><td>FEET PER MINUTE</td> <td>OBD</td><td>OPPOSED BLADE DAMPER</td> </tr> <tr> <td>A.F.F.</td><td>ABOVE FINISHED FLOOR</td> <td>F.S.D.</td><td>FIRE/SMOKE DAMPER</td> <td>O.C.</td><td>ON CENTER</td> </tr> <tr> <td>AHU</td><td>AIR HANDLING UNIT</td> <td>FT</td><td>FEET, FOOT</td> <td>O.H.</td><td>OVERHEAD</td> </tr> <tr> <td>AP</td><td>ACCESS PANEL</td> <td>GFCI</td><td>GROUND FAULT CURRENT INTERRUPTER</td> <td>P</td><td>PUMP</td> </tr> <tr> <td>AS</td><td>AIR SEPARATOR</td> <td>GND.</td><td>GROUND</td> <td>PRV</td><td>PRESSURE REDUCING VALVE</td> </tr> <tr> <td>B</td><td>BOILER</td> <td>GPM</td><td>GALLONS PER MINUTE</td> <td>PSIG</td><td>POUNDS PER SQUARE INCH</td> </tr> <tr> <td>B.F.</td><td>BELOW FLOOR</td> <td>GW</td><td>GREASE WASTE</td> <td>QTY.</td><td>QUANTITY</td> </tr> <tr> <td>B.G.</td><td>BELOW GRADE</td> <td>H</td><td>HOOD</td> <td>RA</td><td>RETURN AIR</td> </tr> <tr> <td>CB</td><td>CIRCUIT BREAKER</td> <td>HP</td><td>HORSEPOWER</td> <td>REQ'D</td><td>REQUIRED</td> </tr> <tr> <td>CH</td><td>WATER COOLED CHILLER</td> <td>HW</td><td>HOT WATER</td> <td>RPM</td><td>REVOLUTIONS PER MINUTE</td> </tr> <tr> <td>CISP</td><td>CAST IRON SOIL PIPE</td> <td>HWCP</td><td>HOT WATER CIRCULATION PUMP</td> <td>RTU</td><td>ROOF TOP UNIT</td> </tr> <tr> <td>CKT</td><td>CIRCUIT</td> <td>HZ</td><td>HERTZ</td> <td>SC</td><td>SHARED CIRCUIT</td> </tr> <tr> <td>CLG.</td><td>CEILING</td> <td>IN.</td><td>INCHES</td> <td>S.D.</td><td>SMOKE DAMPER</td> </tr> <tr> <td>C.O.</td><td>CLEANOUT</td> <td>IN. WTR.</td><td>INCHES OF WATER</td> <td>SF</td><td>SUPPLY FAN</td> </tr> <tr> <td>C.P.T.</td><td>COMPRESSION TANK</td> <td>IG</td><td>ISOLATED GROUND</td> <td>SP</td><td>STATIC PRESSURE</td> </tr> <tr> <td>CT</td><td>COOLING TOWER</td> <td>J-BOX</td><td>JUNCTION BOX</td> <td>ST</td><td>STEAM</td> </tr> <tr> <td>CU</td><td>CONDENSING UNIT</td> <td>KVA</td><td>KILOVOLT AMPERE</td> <td>SWBD</td><td>SWITCHBOARD</td> </tr> <tr> <td>CW</td><td>COLD WATER</td> <td>KW</td><td>KILOWATT</td> <td>T.C.</td><td>TIME CLOCK</td> </tr> <tr> <td>DB</td><td>DRY BULB</td> <td>LOUV.</td><td>LOUVER</td> <td>T.E.</td><td>TELEPHONE</td> </tr> <tr> <td>DIA.</td><td>DIAMETER</td> <td>LAT</td><td>LEAVING AIR TEMPERATURE</td> <td>TMV</td><td>THERMOSTATIC MIXING VALVE</td> </tr> <tr> <td>DN.</td><td>DOWN</td> <td>M.V.</td><td>MEDICAL VACUUM</td> <td>TV</td><td>TELEVISION</td> </tr> <tr> <td>DWG.</td><td>DRAWING</td> <td>MAX.</td><td>MAXIMUM</td> <td>TYP.</td><td>TYPICAL</td> </tr> <tr> <td>(E)</td><td>EXISTING ITEM TO REMAIN</td> <td>MIN.</td><td>MINIMUM</td> <td>UH</td><td>UNIT HEATER</td> </tr> <tr> <td>EA</td><td>EACH</td> <td>MLO</td><td>MAIN LUGS ONLY</td> <td>U.N.O.</td><td>UNLESS NOTED OTHERWISE</td> </tr> <tr> <td>EAT</td><td>ENTERING AIR TEMPERATURE</td> <td>MAU</td><td>MAKE UP AIR UNIT</td> <td>V</td><td>VOLT(S)</td> </tr> <tr> <td>ED</td><td>EJECTION DISCHARGE</td> <td>N</td><td>NITROGEN</td> <td>VFD</td><td>VARIABLE FREQUENCY DRIVE</td> </tr> <tr> <td>EF</td><td>EXHAUST FAN</td> <td>N2O</td><td>NITROUS OXIDE</td> <td>V.T.R.</td><td>VENT THRU ROOF</td> </tr> <tr> <td>ESP</td><td>EXTERNAL STATIC PRESSURE</td> <td>N.C.</td><td>NORMALLY CLOSED</td> <td>W.C.O.</td><td>WALL CLEAN OUT</td> </tr> <tr> <td>EWT</td><td>ENTERING WATER TEMPERATURE</td> <td>NIC</td><td>NOT IN CONTRACT</td> <td>WH</td><td>WATER HEATER</td> </tr> <tr> <td>EXST</td><td>EXISTING</td> <td>NL</td><td>NIGHT LIGHT</td> <td>WP</td><td>WEATHERPROOF</td> </tr> <tr> <td>*F</td><td>DEGREES FAHRENHEIT</td> <td>N.O.</td><td>NORMALLY OPEN</td> <td></td><td></td> </tr> </table>				A	AMPERE(S)	F.C.O.	FLOOR CLEAN OUT	N.T.S.	NOT TO SCALE	A.C.	ABOVE COUNTER	F.D.	FIRE DAMPER	O	OXYGEN	A/C	AIR CONDITIONED	FLR	FLOOR	O.A.	OUTSIDE AIR	A.D.	ACCESS DOOR	FPM	FEET PER MINUTE	OBD	OPPOSED BLADE DAMPER	A.F.F.	ABOVE FINISHED FLOOR	F.S.D.	FIRE/SMOKE DAMPER	O.C.	ON CENTER	AHU	AIR HANDLING UNIT	FT	FEET, FOOT	O.H.	OVERHEAD	AP	ACCESS PANEL	GFCI	GROUND FAULT CURRENT INTERRUPTER	P	PUMP	AS	AIR SEPARATOR	GND.	GROUND	PRV	PRESSURE REDUCING VALVE	B	BOILER	GPM	GALLONS PER MINUTE	PSIG	POUNDS PER SQUARE INCH	B.F.	BELOW FLOOR	GW	GREASE WASTE	QTY.	QUANTITY	B.G.	BELOW GRADE	H	HOOD	RA	RETURN AIR	CB	CIRCUIT BREAKER	HP	HORSEPOWER	REQ'D	REQUIRED	CH	WATER COOLED CHILLER	HW	HOT WATER	RPM	REVOLUTIONS PER MINUTE	CISP	CAST IRON SOIL PIPE	HWCP	HOT WATER CIRCULATION PUMP	RTU	ROOF TOP UNIT	CKT	CIRCUIT	HZ	HERTZ	SC	SHARED CIRCUIT	CLG.	CEILING	IN.	INCHES	S.D.	SMOKE DAMPER	C.O.	CLEANOUT	IN. WTR.	INCHES OF WATER	SF	SUPPLY FAN	C.P.T.	COMPRESSION TANK	IG	ISOLATED GROUND	SP	STATIC PRESSURE	CT	COOLING TOWER	J-BOX	JUNCTION BOX	ST	STEAM	CU	CONDENSING UNIT	KVA	KILOVOLT AMPERE	SWBD	SWITCHBOARD	CW	COLD WATER	KW	KILOWATT	T.C.	TIME CLOCK	DB	DRY BULB	LOUV.	LOUVER	T.E.	TELEPHONE	DIA.	DIAMETER	LAT	LEAVING AIR TEMPERATURE	TMV	THERMOSTATIC MIXING VALVE	DN.	DOWN	M.V.	MEDICAL VACUUM	TV	TELEVISION	DWG.	DRAWING	MAX.	MAXIMUM	TYP.	TYPICAL	(E)	EXISTING ITEM TO REMAIN	MIN.	MINIMUM	UH	UNIT HEATER	EA	EACH	MLO	MAIN LUGS ONLY	U.N.O.	UNLESS NOTED OTHERWISE	EAT	ENTERING AIR TEMPERATURE	MAU	MAKE UP AIR UNIT	V	VOLT(S)	ED	EJECTION DISCHARGE	N	NITROGEN	VFD	VARIABLE FREQUENCY DRIVE	EF	EXHAUST FAN	N2O	NITROUS OXIDE	V.T.R.	VENT THRU ROOF	ESP	EXTERNAL STATIC PRESSURE	N.C.	NORMALLY CLOSED	W.C.O.	WALL CLEAN OUT	EWT	ENTERING WATER TEMPERATURE	NIC	NOT IN CONTRACT	WH	WATER HEATER	EXST	EXISTING	NL	NIGHT LIGHT	WP	WEATHERPROOF	*F	DEGREES FAHRENHEIT	N.O.	NORMALLY OPEN		
A	AMPERE(S)	F.C.O.	FLOOR CLEAN OUT					N.T.S.	NOT TO SCALE																																																																																																																																																																																																										
A.C.	ABOVE COUNTER	F.D.	FIRE DAMPER					O	OXYGEN																																																																																																																																																																																																										
A/C	AIR CONDITIONED	FLR	FLOOR					O.A.	OUTSIDE AIR																																																																																																																																																																																																										
A.D.	ACCESS DOOR	FPM	FEET PER MINUTE					OBD	OPPOSED BLADE DAMPER																																																																																																																																																																																																										
A.F.F.	ABOVE FINISHED FLOOR	F.S.D.	FIRE/SMOKE DAMPER					O.C.	ON CENTER																																																																																																																																																																																																										
AHU	AIR HANDLING UNIT	FT	FEET, FOOT					O.H.	OVERHEAD																																																																																																																																																																																																										
AP	ACCESS PANEL	GFCI	GROUND FAULT CURRENT INTERRUPTER					P	PUMP																																																																																																																																																																																																										
AS	AIR SEPARATOR	GND.	GROUND					PRV	PRESSURE REDUCING VALVE																																																																																																																																																																																																										
B	BOILER	GPM	GALLONS PER MINUTE					PSIG	POUNDS PER SQUARE INCH																																																																																																																																																																																																										
B.F.	BELOW FLOOR	GW	GREASE WASTE					QTY.	QUANTITY																																																																																																																																																																																																										
B.G.	BELOW GRADE	H	HOOD					RA	RETURN AIR																																																																																																																																																																																																										
CB	CIRCUIT BREAKER	HP	HORSEPOWER					REQ'D	REQUIRED																																																																																																																																																																																																										
CH	WATER COOLED CHILLER	HW	HOT WATER					RPM	REVOLUTIONS PER MINUTE																																																																																																																																																																																																										
CISP	CAST IRON SOIL PIPE	HWCP	HOT WATER CIRCULATION PUMP					RTU	ROOF TOP UNIT																																																																																																																																																																																																										
CKT	CIRCUIT	HZ	HERTZ	SC	SHARED CIRCUIT																																																																																																																																																																																																														
CLG.	CEILING	IN.	INCHES	S.D.	SMOKE DAMPER																																																																																																																																																																																																														
C.O.	CLEANOUT	IN. WTR.	INCHES OF WATER	SF	SUPPLY FAN																																																																																																																																																																																																														
C.P.T.	COMPRESSION TANK	IG	ISOLATED GROUND	SP	STATIC PRESSURE																																																																																																																																																																																																														
CT	COOLING TOWER	J-BOX	JUNCTION BOX	ST	STEAM																																																																																																																																																																																																														
CU	CONDENSING UNIT	KVA	KILOVOLT AMPERE	SWBD	SWITCHBOARD																																																																																																																																																																																																														
CW	COLD WATER	KW	KILOWATT	T.C.	TIME CLOCK																																																																																																																																																																																																														
DB	DRY BULB	LOUV.	LOUVER	T.E.	TELEPHONE																																																																																																																																																																																																														
DIA.	DIAMETER	LAT	LEAVING AIR TEMPERATURE	TMV	THERMOSTATIC MIXING VALVE																																																																																																																																																																																																														
DN.	DOWN	M.V.	MEDICAL VACUUM	TV	TELEVISION																																																																																																																																																																																																														
DWG.	DRAWING	MAX.	MAXIMUM	TYP.	TYPICAL																																																																																																																																																																																																														
(E)	EXISTING ITEM TO REMAIN	MIN.	MINIMUM	UH	UNIT HEATER																																																																																																																																																																																																														
EA	EACH	MLO	MAIN LUGS ONLY	U.N.O.	UNLESS NOTED OTHERWISE																																																																																																																																																																																																														
EAT	ENTERING AIR TEMPERATURE	MAU	MAKE UP AIR UNIT	V	VOLT(S)																																																																																																																																																																																																														
ED	EJECTION DISCHARGE	N	NITROGEN	VFD	VARIABLE FREQUENCY DRIVE																																																																																																																																																																																																														
EF	EXHAUST FAN	N2O	NITROUS OXIDE	V.T.R.	VENT THRU ROOF																																																																																																																																																																																																														
ESP	EXTERNAL STATIC PRESSURE	N.C.	NORMALLY CLOSED	W.C.O.	WALL CLEAN OUT																																																																																																																																																																																																														
EWT	ENTERING WATER TEMPERATURE	NIC	NOT IN CONTRACT	WH	WATER HEATER																																																																																																																																																																																																														
EXST	EXISTING	NL	NIGHT LIGHT	WP	WEATHERPROOF																																																																																																																																																																																																														
*F	DEGREES FAHRENHEIT	N.O.	NORMALLY OPEN																																																																																																																																																																																																																
	GROUND ROD		HAND-OFF-AUTO SWITCH		START/STOP STATION																																																																																																																																																																																																														
	GROUND		AUXILIARY SWITCH - FIRST LETTER DENOTES SWITCH TYPE P=PRESSURE; T=TEMPERATURE; V=VIBRATION; F=FLOW		ON/OFF SWITCH																																																																																																																																																																																																														
	TRANSFORMER , PAD MOUNT/POLE MOUNT AS SCHEDULED		STOP PUSH BUTTON																																																																																																																																																																																																																
	EMERGENCY MANAGEMENT CONTROL SYSTEM PANEL																																																																																																																																																																																																																		
C-TV	CABLE TV OUTLET	STANDARD SYMBOLS - LIGHTING																																																																																																																																																																																																																	
	EXPOSED RACEWAY , CROSS LINES INDICATE WIRE NUMBER (-PHASE, -NEUTRAL, -SWITCH, -GROUND)		WALL PACK , WALL MOUNT																																																																																																																																																																																																																
	CONCEALED RACEWAY , IN WALLS OR ABOVE CEILING		LED LIGHT , WALL MOUNT																																																																																																																																																																																																																
	POINT OF CONNECTION FROM NEW TO EXISTING CONSTRUCTION		LED LIGHT , WALL MOUNT, EMERGENCY																																																																																																																																																																																																																
	HOMERUN , NUMBER OF ARROWS INDICATES NUMBER OF PHASES		LED LIGHT , RECESSED MOUNT																																																																																																																																																																																																																
	MOTOR CONTROLLER , MOUNT TOP AT 72" ABOVE FLOOR UNLESS NOTE OTHERWISE																																																																																																																																																																																																																		

GENERAL NOTES:

ALL WORK SHALL BE PERFORMED IN ACCORDANCE WITH CODES ADOPTED BY THE AUTHORITY HAVING JURISDICTION (AHJ) AND THE REQUIREMENTS STATED IN THE RFP, UNITED FACILITY CRITERIA AND APPLICABLE SECTIONS OF THE NATIONAL FIRE CODES (NFPA STANDARDS) CURRENT AT THE RFP WAS AMENDMENTS TO THESE CODES AS SET FORTH BY THE AUTHORITY HAVING JURISDICTION SHALL SUPERSEDE THESE CODES AND NFPA STANDARDS AS ISSUED.

1. INTERRELATION BETWEEN THE DRAWINGS AND THE SPECIFICATIONS: IN GENERAL, THE DRAWINGS INDICATE LOCATIONS, QUANTITIES AND CAPACITIES AND THE SPECIFICATIONS INDICATE QUALITY, OPTIONS, WARRANTIES AND COMPLIANCE STANDARDS. IN THE EVENT THERE IS A CONFLICT BETWEEN THE DRAWINGS, THE GREATER QUALITY OR QUANTITY SHALL BE REQUIRED. IN ALL CASES, THE ENGINEER OF RECORD SHALL BE THE INTERPRETER OF THE DOCUMENTS.

2. INTERRELATION BETWEEN THE DRAWINGS: IN THE EVENT OF A CONFLICT BETWEEN A DETAIL AND A FLOOR PLAN, THE LARGER SIZE, QUANTITY, LENGTH OR OPTIONS SHALL BE REQUIRED. IN THE EVENT OF CONFLICT BETWEEN WHAT IS SHOWN ON THE FLOOR PLAN AND A KEYED NOTE, THE KEYED NOTE SHALL GOVERN. IN ALL CASES, THE ENGINEER OF RECORD SHALL BE THE INTERPRETER OF THE DOCUMENTS.

3. PRIOR TO BIDDING, THE DIVISION 26 INSTALLER SHALL VISIT THE JOB SITE TO BECOME FAMILIAR WITH EXISTING CONDITIONS AND TO VERIFY LOCATIONS AND SIZES OF EXISTING EQUIPMENT, CONDUCTORS, ETC. SUBMITTAL OF A BID SHALL SIGNIFY WILLINGNESS TO COMPLY WITH THE CONSTRUCTION DOCUMENTS AND ACCEPTANCE OF ON-SITE CONDITIONS AS THEY EXIST.

4. THE EXISTENCE AND LOCATION OF UTILITIES, MECHANICAL SYSTEMS, ELECTRICAL SYSTEMS AND OTHER CONSTRUCTION INDICATED AS EXISTING ARE NOT GUARANTEED. BEFORE BEGINNING WORK, INVESTIGATE AND VERIFY THE EXISTENCE AND LOCATION OF MECHANICAL AND ELECTRICAL SYSTEMS AND OTHER CONSTRUCTION AFFECTING THE WORK.

5. COOPERATE FULLY WITH SEPARATE CONTRACTORS SO WORK ON THOSE CONTRACTS MAY BE CARRIED OUT SMOOTHLY WITHOUT INTERFERING WITH OR DELAYING WORK UNDER THIS CONTRACT. COORDINATE THE WORK OF THIS CONTRACT WITH WORK PERFORMED UNDER SEPARATE CONTRACTS.

6. DO NOT INTERRUPT UTILITIES SERVING FACILITIES OCCUPIED BY GOVERNMENT OR OTHERS UNLESS PERMITTED BY THE GOVERNMENT. THE CONTRACTOR SHALL PROVIDE 14 DAYS NOTIFICATION, UON OF THE DRAWINGS ARE DIAGRAMMATIC ONLY AND SHALL NOT BE SCALED. NOT ALL NEC REQUIRED ITEMS SUCH AS RACEWAYS, CONDUCTORS, GROUNDING SYSTEMS, ETC. CAN BE SHOWN. FURNISH AND INSTALL RACEWAYS, CONDUCTORS, ETC. AS REQUIRED FOR A COMPLETE AND FUNCTIONAL, NEC COMPLIANT SYSTEM.

7. THE INSTALLER IS RESPONSIBLE FOR COORDINATING WITH OTHER TRADES. THE INSTALLER SHALL NOT INSTALL OR FABRICATE ANY WORK SHOWN UNTIL ALL SUCH WORK IS FULLY COORDINATED, FURNISH AND INSTALL ADDITIONAL RACEWAYS, CONDUCTORS, ETC. AS REQUIRED TO COORDINATE THE INSTALLATION WITH OTHER TRADES AS PART OF THE WORK.

8. TAKE FIELD MEASUREMENTS AS REQUIRED TO FIT THE WORK PROPERLY, RECHECK MEASUREMENTS BEFORE INSTALLING EACH PRODUCT. WHERE PORTIONS OF THE WORK ARE INDICATED TO FIT TO OTHER CONSTRUCTION, VERIFY DIMENSIONS OF OTHER CONSTRUCTION BY FIELD MEASUREMENTS BEFORE FABRICATION. COORDINATE FABRICATION SCHEDULE WITH CONSTRUCTION PROGRESS TO AVOID DELAYING THE WORK. FURNISH AND INSTALL ADDITIONAL RACEWAYS, CONDUCTORS, ETC. AS REQUIRED TO ACCOMMODATE FIELD CONDITIONS AS PART OF THE WORK.

9. THE WORK SHALL BE SUPERVISED BY A MASTER ELECTRICIAN TO ASSURE THAT ALL WORK IS INSTALLED IN ACCORDANCE WITH APPLICABLE CODES AND THE CONSTRUCTION DOCUMENTS.

10. REFER TO ARCHITECTURAL REFLECTED CEILING PLANS FOR EXACT LOCATIONS OF LIGHTING FIXTURES.

11. IT SHALL BE THE RESPONSIBILITY OF THE CONTRACTOR TO RELOCATE TO THE PROPER SIDE OF THE DOOR ANY SWITCH, RECEPTACLE OR DEVICE BEING AFFECTED BY ANY CHANGE IN DIRECTION OF DOOR SWINGS AS SHOWN ON THE ARCHITECTURAL FLOOR PLAN.

12. MECHANICAL EQUIPMENT SIZES ARE AS DESIGNED, BREAKERS, CONDUIT STARTERS, CONDUCTORS, ETC. SHALL BE ADJUSTED TO THE EQUIPMENT SUBMITTED AND APPROVED FOR INSTALLATION ON THIS PROJECT.

13. REMOTE MOUNTED MOTORS SHALL BE PROVIDED WITH RECEPTACLES AND PLUGS OR DISCONNECT SWITCHES TO BE COMPATIBLE WITH THE CONSTRUCTION TYPE AND THE NEC. EACH MOTOR BEING INSTALLED ON THIS CONTRACT SHALL BE PROVIDED WITH THERMAL PROTECTION IN EITHER A MANUAL OR MAGNETIC STARTER. THERMAL ELEMENTS SHALL BE SIZED AND INSTALLED ACCORDING TO THE NAMEPLATE FULL LOAD AMP RATING OF THE MOTOR.

14. KILOWATT (KW) RATINGS FOR EQUIPMENT MOTOR LOADS ARE AS DESIGNED WITH 90% POWER FACTOR RATING ASSUMED. THE CONTRACTOR SHALL BE RESPONSIBLE FOR INCREASING THE SIZE, AS REQUIRED, OF ALL FEEDERS AND PROTECTIVE DEVICES SERVING ANY ITEMS OF EQUIPMENT SUPPLIED WITH POWER FACTOR RATINGS LESS THAN 90% EFFICIENCY.

15. IN ALL AREAS THE GENERAL CONTRACTOR SHALL BE RESPONSIBLE FOR COORDINATION BETWEEN THE ELECTRICAL AND MECHANICAL TRADES TO PROVIDE CLEARANCE ABOVE CEILING BETWEEN RECESSED LIGHTING FIXTURES AND THERMAL INSULATION OR DUCTWORK IN ACCORDANCE WITH THE NEC, PARAGRAPH 410-66.

16. A CIRCUIT SHALL BE DEFINED TO INCLUDE ALL OF THE FOLLOWING: CONDUIT, CONDUCTORS, BOXES, WIRING DEVICES, COVERPLATES, WIREWAYS, ETC.

17. MULTIWIRE BRANCH CIRCUITS AS DEFINED BY THE NATIONAL ELECTRICAL CODE SHALL NOT BE USED. A DEDICATED NEUTRAL CONDUCTOR SHALL BE RUN FOR EACH BRANCH CIRCUIT, UON.

18. THE CONTRACTOR SHALL LABEL EACH JUNCTION/PULL BOX COVER PLATE WITH THE CIRCUIT NUMBER OF THE CIRCUITS IT CONTAINS. LABEL EACH EXISTING CONDUIT AT THE POINT WHERE IT EXITS THE JUNCTION BOX WITH THE CIRCUIT NUMBER IT CONTAINS. IF THE RACEWAY SYSTEM IS IN AN EXPOSED AREA LABEL THE INSIDE OF THE JUNCTION/PULL BOX COVER PLATE ONLY.

19. LABEL THE RECEPTACLE AND LIGHT SWITCH FACEPLATES WITH THE CIRCUIT DESIGNATION. THE LABEL SHALL BE CLEAR WITH 1/4" BLACK LETTERS AND SHALL BE MACHINE PRINTED.

20. RECEPTACLES RATED FOR 15A OR 20A/125V AND INSTALLED WITHIN 6FT OF THE OUTSIDE OF A SINK SHALL BE GFCI PROTECTED. IF THE RECEPTACLE IS NOT ACCESSIBLE THEN GFCI PROTECTED CIRCUIT BREAKER SHALL BE USED.

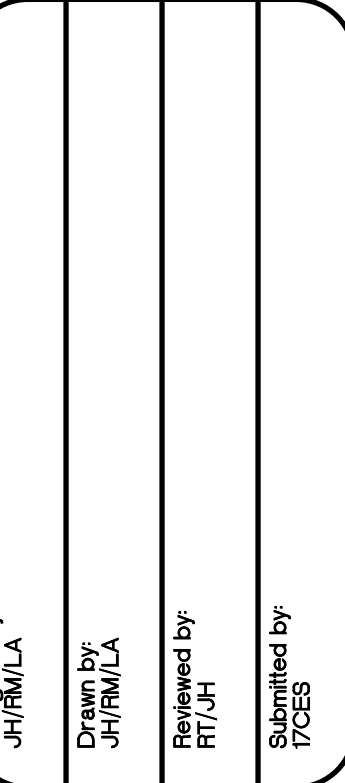
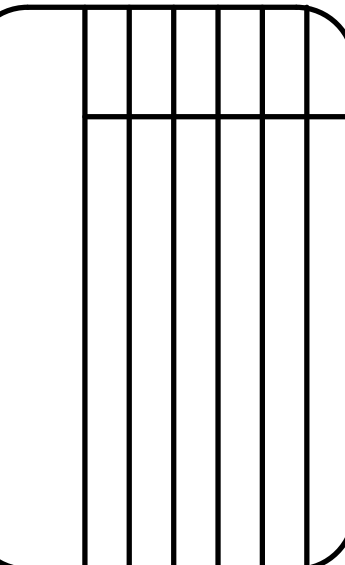

FIRE STATION ADD/ALTER, B3321
PROJECT NO. 1039839
17th TRAINING WING
GOODFELLOW AIR FORCE BASE, TEXAS

PROJECT TITLE

Project Number:
1039839

SHEET TITLE
ELECTRICAL SYMBOLS NOTES & ABBREVIATIONS

Date:
SEP 2023

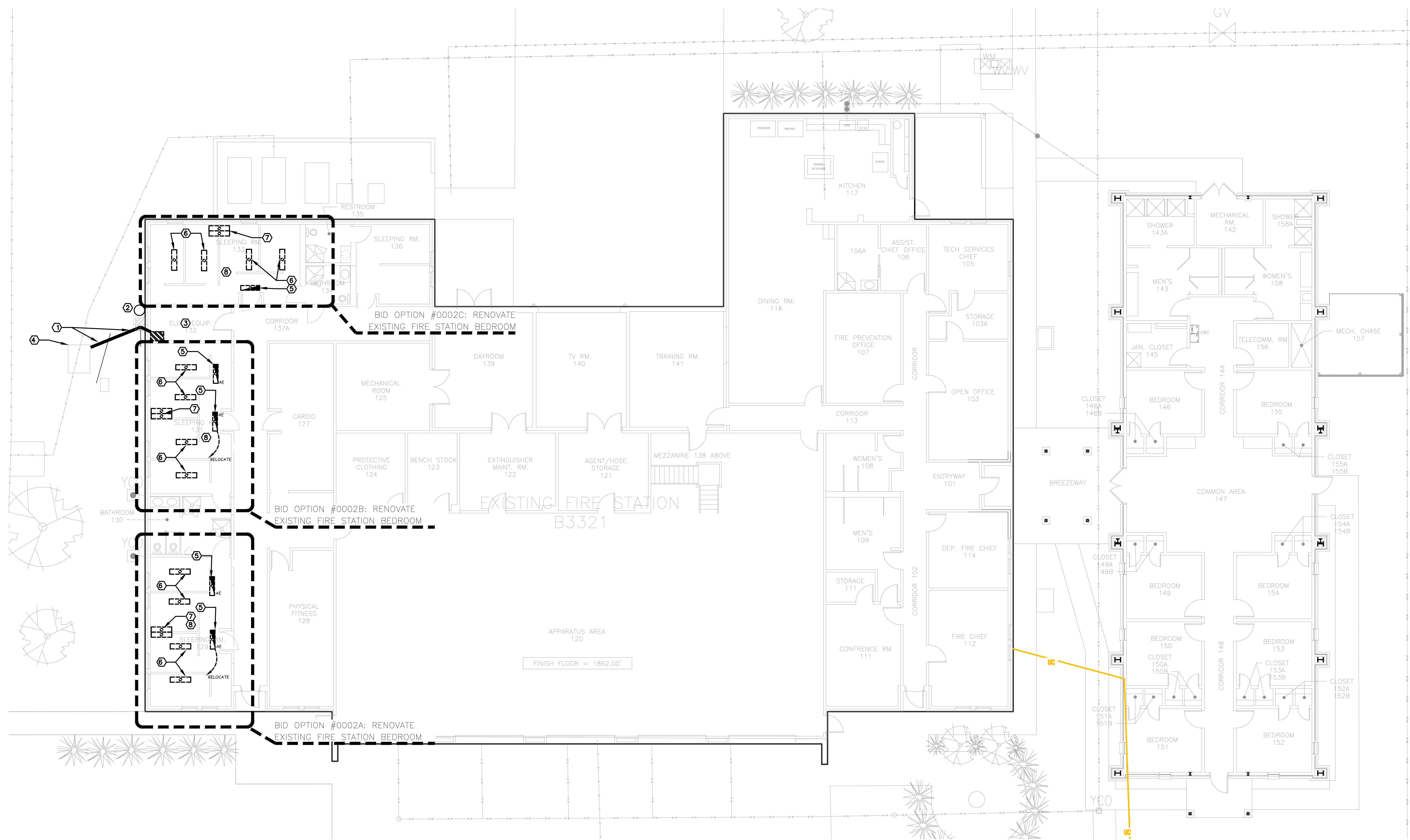

KEYNOTES AS NOTATED BY (X)

1. EXISTING UNDERGROUND SERVICE CIRCUIT FROM TRANSFORMER TO MAIN DISTRIBUTION PANEL (MDP)
2. CONTRACTOR SHALL DEMO EXISTING MAIN SERVICE DISCONNECT AND METER.
3. CONTRACTOR SHALL DEMOLISH EXISTING MDP.
4. EXISTING 150KVA TRANSFORMER AND PAD
5. CONTRACTOR SHALL REMOVE AND REPLACE EXISTING EMERGENCY LIGHTING IN ROOMS 129 AND 131. NEW LAMPS SHALL BE CONNECTED TO THE SAME CIRCUIT FEEDING EMERGENCY LIGHTING IN THESE TWO ROOMS.
6. CONTRACTOR SHALL REMOVE AND REPLACE EXISTING LIGHT FIXTURES WITH NEW DIMMABLE LED EQUIVALENT AS SHOWN ON E601 LIGHTING SCHEDULE. REPLACE SWITCHES CONTROLLING THESE LIGHTS BY SWITCHES. CONTRACTOR SHALL ENSURE TO RELOCATE SWITCHES FOR EACH NEWLY PARTITIONED ROOM.
7. CONTRACTOR SHALL DEMOLISH EXISTING WALL MOUNTED FIXTURES. EXISTING CIRCUITS ARE TO REMAIN AND ENCLOSED IN JUNCTION BOXES ABOVE THE CEILING.
8. CONTRACTOR SHALL RELOCATE CIRCUITS IN BID OPTION ROOMS AS NEEDED TO ALLOW FOR NEW RECESSED FIXTURES AS SHOWN ON A-201

GENERAL NOTES

1. THESE WORK PLANS ARE ONLY MEANT TO CONVEY THE SCOPE OF WORK FOR CONTRACTOR BIDDING AND REFERENCE PURPOSES ONLY. THE CONTRACTOR SHALL BE RESPONSIBLE FOR PROVIDING ALL NECESSARY PLANS, DRAWINGS, LINE DIAGRAMS, PANEL AND LOAD CALCULATIONS BEARING THE SEAL OF AN ELECTRICAL ENGINEER TO ENSURE THE COMPLETE INSTALLATION OF ALL NECESSARY ELECTRICAL SYSTEMS IN THE NEW ADDITION AND BID OPTION AREAS, IF AWARDED.
2. CONTRACTOR SHALL BE RESPONSIBLE FOR VERIFYING EXISTING CONDITIONS, EQUIPMENT, CURRENT PANEL CAPACITY, NEW LOAD REQUIREMENTS, AND DIMENSIONS PRIOR TO START OF WORK.
3. PLACEMENT OF NEW SERVICE CIRCUIT, NEW MAIN SERVICE DISCONNECT, AND NEW MDP SHALL BE DONE BEFORE DEMOLITION. CONTRACTOR SHALL PROVIDE TEMPORARY POWER TO FACILITY TO AVOID POWER INTERRUPTION. THE CONTRACTOR SHALL ENSURE TO HAVE ELECTRICAL EQUIPMENT AND MATERIALS INCLUDING PANELS, SWITCHES, WIRING, CONDUIT, AND ACCESSORIES READY AND AVAILABLE AT THE SITE PRIOR TO BEGINNING WORK ON THE EXISTING FIRE STATION.
4. THE CONTRACTOR SHALL COORDINATE HIS/HER WORK WITH THAT OF ALL OTHER TRADES, INCLUDING BUT NOT LIMITED TO, ELECTRICAL, HVAC, STRUCTURAL AND GENERAL ARCHITECTURE.
5. EXISTING OUTLETS AND RECEPTACLES IN BID OPTION ROOMS ARE TO REMAIN UNLESS NOTED OTHERWISE.
6. THE GOVERNMENT HAS CONFIRMED WITH AEP, AS THE PRIMARY UTILITY PROVIDER, THAT A NEW, AND OR, UPSIZED TRANSFORMER WILL NOT BE REQUIRED TO PERFORM THE DESCRIBED IN THESE DRAWINGS.
7. CONTRACTOR SHALL DO ALL ELECTRICAL INSTALLATION ACCORDING NEC AND UFC STANDARDS.
8. IN BID OPTION AREAS, THE CONTRACTOR SHALL BE RESPONSIBLE FOR DEMOLISHING ANY EXISTING PUBLIC ANNOUNCING (PA) SPEAKERS, AND REUSING EXISTING CIRCUITS FOR NEW WORK. CONTRACTOR SHALL INSTALL NEW SOFT-START PUBLIC ANNOUNCING SPEAKERS IN EACH BEDROOM SIMILAR TO THOSE REQUIRED IN THE NEW ADDITION.

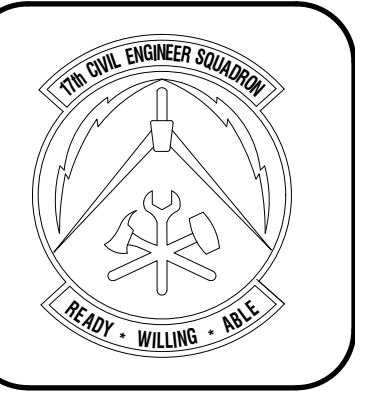

Designed by JH/RML/LA	
Drawn by JH/RML/LA	
Reviewed by RT/JH	
Submitted by PC/ES	

PROJECT TITLE
FIRE STATION ADD/ALTER, B3321
PROJECT NO. 1039839
17th TRAINING WING
GOODFELLOW AIR FORCE BASE, TEXAS

Project Number: 1039839
SHEET TITLE ELECTRICAL DEMOLITION PLAN
Date: SEP 2023

SEQ.	SHEET	OF
39	ED-101	50

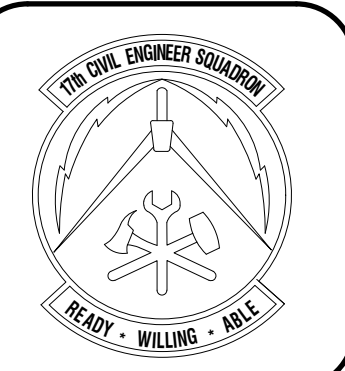

--	--	--	--	--	--	--

Designed by JH/ML/A	Drawn by JH/ML/A	Reviewed by RT/JH	Submitted by PC/ES
------------------------	---------------------	----------------------	-----------------------

PROJECT TITLE
FIRE STATION ADD/ALTER, B3321
PROJECT NO. 1039839
17th TRAINING WING
GOODFELLOW AIR FORCE BASE, TEXAS

Project Number:	1039839
SHEET TITLE	ELECTRICAL POWER SUPPLY
Date:	SEP 2023

SEQ.	SHEET	OF
40	F-101	50

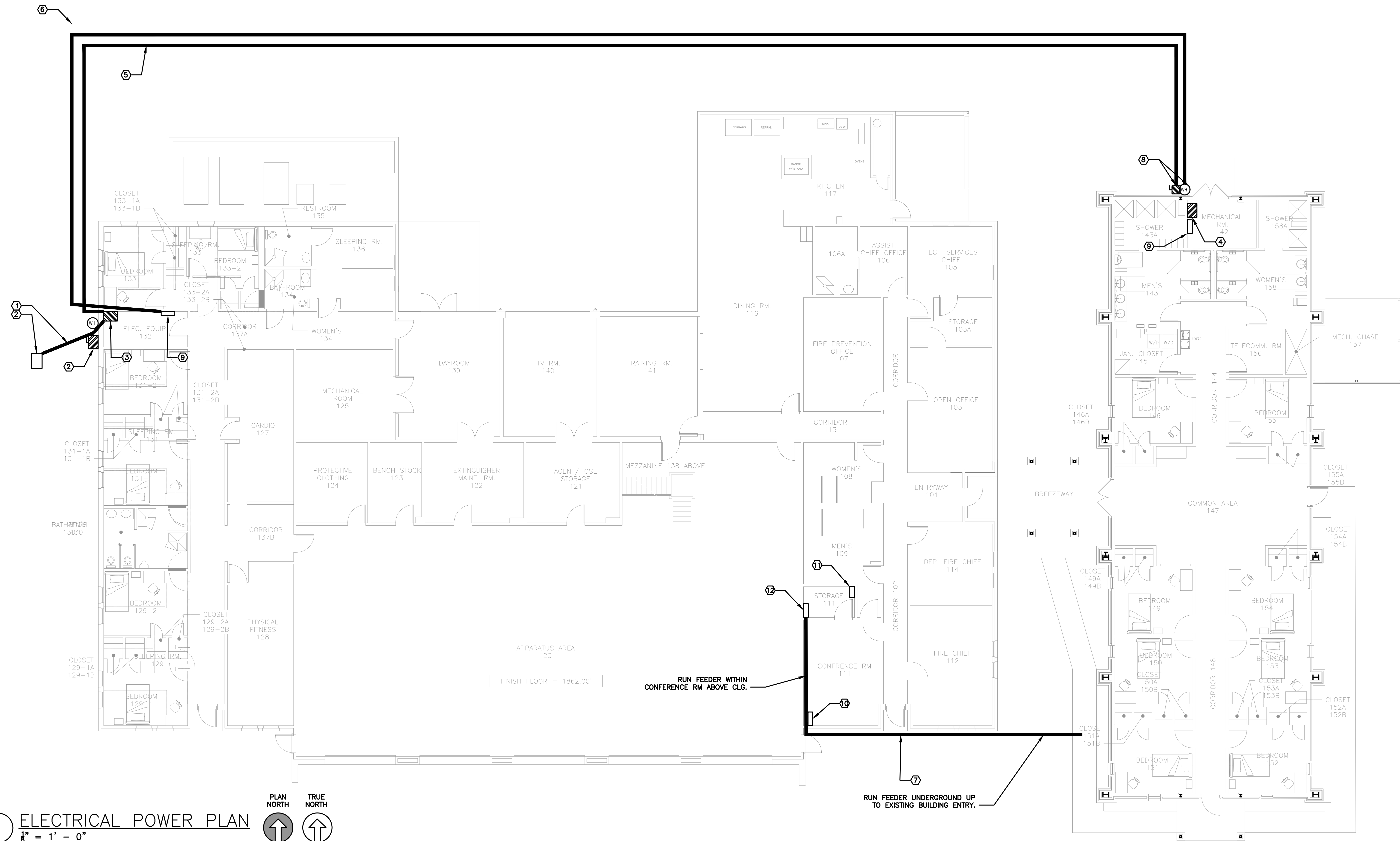

1 ELECTRICAL POWER PLAN
 $\frac{1}{8}'' = 1' - 0''$

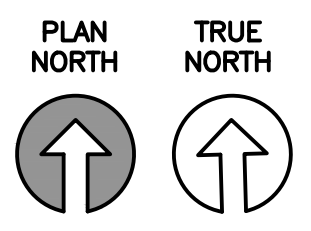

- KEYNOTES** AS INDICATED BY (X)
- EXISTING UNDERGROUND SERVICE CONNECTION.
 - CONTRACTOR SHALL PROVIDE NEW GROUNDED MAIN SERVICE DISCONNECT AND METER. SIZE AND TYPE AS DETERMINED BY ELECTRICAL ENGINEER.
 - CONTRACTOR SHALL SIZE, FURNISH, AND INSTALL A NEW MAIN DISTRIBUTION PANEL AS NEEDED TO SUPPORT CURRENT FIRE STATION FUNCTIONS AND NEW BUILDING ADDITION.
 - CONTRACTOR SHALL PROVIDE NEW D1 PANEL INSIDE NEW ADDITION BUILDING MECHANICAL ROOM, INCLUDING NEW METER AND MAIN DISCONNECT OUTSIDE MECH ROOM. ALL D1 PANEL CIRCUIT BREAKERS SHALL BE INVERSE TIME CB RATED FOR OVERLOAD PROTECTION.
 - CONTRACTOR SHALL PROVIDE NEW 250FT UNDERGROUND FEEDER CIRCUIT FROM MDP TO D1
 - CONTRACTOR SHALL PROVIDE NEW C-TV FEEDER IN PVC CONDUIT FROM EXISTING SUDENLINK SERVICE ENTRANCE TO NEW C-TV SPLITTER BOX. CONTRACTOR SHALL PROVIDE ALL NEEDED EQUIPMENT IN EXISTING SUDENLINK ENTRANCE TO ACCOMMODATE NEW CONNECTION. NEW FLUSH MOUNTED SPLITTER BOX SHALL COLLECT ALL C-TV IN NEW BUILDING. SEE E-301
 - NEW VOICE/DATA/PA FEEDER FROM NEW BUILDING TO EXISTING TELEPHONE BOARD/DATA SWITCHES/SPEAKER BOX. CONTRACTOR SHALL PROVIDE NEW TELEPHONE/DATA/PA FEEDER IN PVC CONDUIT FROM NEW BUILDING FLUSH MOUNTED COLLECTION POINT BOX TO EXISTING TELEPHONE BOARD/DATA SWITCHES/SPEAKERS AMPLIFIER BOX. CONTRACTOR SHALL PROVIDE NEW DATA SWITCH NEXT TO EXISTING ONES ON B3321 TO ACCOMMODATE FOR NEW DEMAND. REFER TO DIVISION 27 "STATEMENT OF OBJECTIVES (SOO)" FOR ADDITIONAL INFORMATION.
 - REFER TO ONE-LINE DIAGRAM ON E-601 FOR CIRCUIT/CONDUCTORS SPECIFICATIONS.
 - EXISTING C-TV BOX
 - EXISTING SPEAKER AMPLIFIER BOX
 - EXISTING RELAYS CONTROL BOX

- GENERAL NOTES**
12. EXISTING TELEPHONE BOARD AND DATA SWITCHES
 - THESE WORK PLANS ARE ONLY MEANT TO CONVEY THE SCOPE OF WORK FOR CONTRACTOR BIDDING AND REFERENCE PURPOSES ONLY. THE CONTRACTOR SHALL BE RESPONSIBLE FOR PROVIDING ALL NECESSARY PLANS, DRAWINGS, LINE DIAGRAMS, PANEL AND LOAD CALCULATIONS BEARING THE SEAL OF AN ELECTRICAL ENGINEER TO ENSURE THE COMPLETE INSTALLATION OF ALL NECESSARY ELECTRICAL SYSTEMS IN THE NEW ADDITION AND BID OPTION AREAS, IF AWARDED.
 - CONTRACTOR SHALL BE RESPONSIBLE FOR VERIFYING EXISTING CONDITIONS, EQUIPMENT, CURRENT PANEL CAPACITY, NEW LOAD REQUIREMENTS, AND DIMENSIONS PRIOR TO START OF WORK.
 - PLACEMENT OF NEW SERVICE CIRCUIT, NEW MAIN SERVICE DISCONNECT, AND NEW MDP SHALL BE DONE BEFORE DEMOLITION. CONTRACTOR SHALL PROVIDE TEMPORARY POWER TO FACILITY TO AVOID POWER INTERRUPTION. THE CONTRACTOR SHALL ENSURE TO HAVE ELECTRICAL EQUIPMENT AND MATERIALS INCLUDING PANELS, SWITCHES, WIRING, CONDUIT, AND ACCESSORIES READY AND AVAILABLE AT THE SITE PRIOR TO BEGINNING WORK ON THE EXISTING FIRE STATION.
 - THE CONTRACTOR SHALL COORDINATE HIS/HER WORK WITH THAT OF ALL OTHER TRADES, INCLUDING BUT NOT LIMITED TO, ELECTRICAL, HVAC, STRUCTURAL AND GENERAL ARCHITECTURE.
 - EXISTING OUTLETS AND RECEPTACLES IN BID OPTION ROOMS ARE TO REMAIN UNLESS NOTED OTHERWISE.
 - THE GOVERNMENT HAS CONFIRMED WITH AEP, AS THE PRIMARY UTILITY PROVIDER, THAT A NEW, AND OR, UPSIZED TRANSFORMER WILL NOT BE REQUIRED TO PERFORM THE DESCRIBED IN THESE DRAWINGS.
 - CONTRACTOR SHALL DO ALL ELECTRICAL INSTALLATION ACCORDING NEC AND UFC STANDARDS.

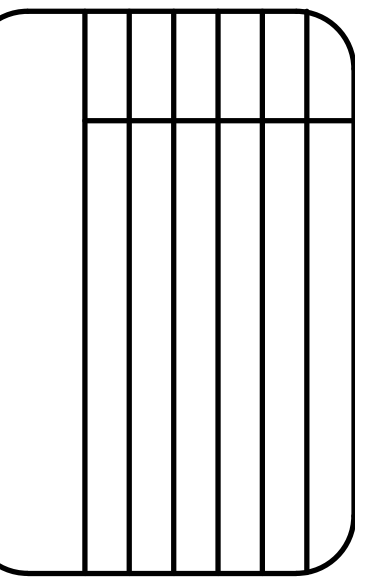
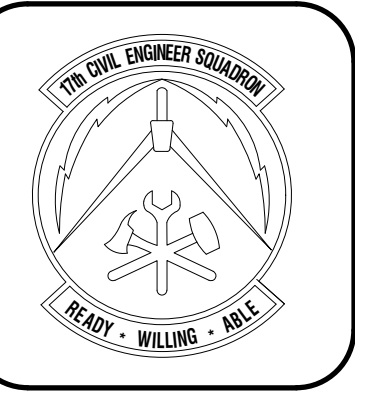

Designed by
JH/MLA
Drawn by
JH/MLA
Reviewed by
RT/JH
Submitted by
PC/ES

PROJECT TITLE
**FIRE STATION ADD/ALTER, B3321
PROJECT NO. 1039839
17th TRAINING WING
GOODFELLOW AIR FORCE BASE, TEXAS**

Project Number:
1039839
SHEET TITLE
LIGHTING PLAN
Date:
SEP 2023

SEQ. SHEET OF
41 **E-201** 50

KEYNOTES AS INDICATED BY (X)

1. ALL SWITCHES SA AND LIGHTS CONTROLLED BY THEM SHALL BE DIMMABLE SWITCHES
2. ALL CORRIDOR LIGHTING SHALL BE CONTROLLED BY OCCUPANCY SENSORS
3. NOT USED
4. OUTDOOR LIGHTING SHALL BE PHOTOCELL CONTROLLED AS INDICATED. CONTRACTOR SHALL PROVIDE SURFACE MOUNTED LED WALL PACKS ABOVE MECH. RM 142 AND EAST COMMON AREA RM147 ENTRANCES. COORDINATE WITH GAFB BASE STANDARDS FOR STANDARD PRODUCT TYPE.
5. RESTROOM LIGHTS TO BE CONTROLLED BY OCCUPANCY SENSORS.
6. CONTRACTOR SHALL PROVIDE SURFACE MOUNTED 6" LED ROUND LIGHTING, COMPLETE WITH CIRCUIT, AND CONDUIT BENEATH PORCH CANOPY AND BREEZEWAY. COORDINATE WITH GAFB BASE STANDARDS FOR STANDARD PRODUCT TYPE.

GENERAL NOTES

1. THESE WORK PLANS ARE ONLY MEANT TO CONVEY THE SCOPE OF WORK FOR CONTRACTOR BIDDING AND REFERENCE PURPOSES ONLY. THE CONTRACTOR SHALL BE RESPONSIBLE FOR PROVIDING ALL NECESSARY PLANS, DRAWINGS, LINE DIAGRAMS, PANEL AND LOAD CALCULATIONS BEARING THE SEAL OF AN ELECTRICAL ENGINEER TO ENSURE THE COMPLETE INSTALLATION OF ALL NECESSARY ELECTRICAL SYSTEMS IN THE NEW ADDITION AND BID OPTION AREAS, IF AWARDED.
2. CONTRACTOR SHALL BE RESPONSIBLE FOR VERIFYING EXISTING CONDITIONS, EQUIPMENT, CURRENT PANEL CAPACITY, NEW LOAD REQUIREMENTS, AND DIMENSIONS PRIOR TO START OF WORK.
3. PLACEMENT OF NEW SERVICE CIRCUIT, NEW MAIN SERVICE DISCONNECT, AND NEW MDP SHALL BE DONE BEFORE DEMOLITION. CONTRACTOR SHALL PROVIDE TEMPORARY POWER TO FACILITY TO AVOID POWER INTERRUPTION. THE CONTRACTOR SHALL ENSURE TO HAVE ELECTRICAL EQUIPMENT AND MATERIALS INCLUDING PANELS, SWITCHES, WIRING, CONDUIT, AND ACCESSORIES READY AND AVAILABLE AT THE SITE PRIOR TO BEGINNING WORK ON THE EXISTING FIRE STATION.
4. THE CONTRACTOR SHALL COORDINATE HIS/HER WORK WITH THAT OF ALL OTHER TRADES, INCLUDING BUT NOT LIMITED TO, ELECTRICAL, HVAC, STRUCTURAL AND GENERAL ARCHITECTURE.
5. EXISTING OUTLETS AND RECEPTACLES IN BID OPTION ROOMS ARE TO REMAIN UNLESS NOTED OTHERWISE.
6. THE GOVERNMENT HAS CONFIRMED WITH AEP, AS THE PRIMARY UTILITY PROVIDER, THAT A NEW, AND OR, UPSIZED TRANSFORMER WILL NOT BE REQUIRED TO PERFORM THE DESCRIBED IN THESE DRAWINGS.
7. CONTRACTOR SHALL DO ALL ELECTRICAL INSTALLATION ACCORDING NEC AND UFC STANDARDS.
8. ALL CONDUCTORS SHALL BE IN CONCEALED EMT CONDUITS IN WALLS OR ABOVE CEILING FOR INTERIOR APPLICATIONS AND IMC CONDUITS FOR EXTERIOR APPLICATIONS UNLESS NOTED OTHERWISE
9. MINIMUM CONDUCTOR SIZE ALLOWED IS #12 COPPER
10. CONTRACTOR SHALL PROVIDE ALL REQUIRED EQUIPMENTS TO PERFORM THIS JOB ACCORDING CODE, INDUSTRY STANDARDS, AND AS DESCRIBED EVEN IF ALL EQUIPMENT IS NOT LISTED ON THESE DRAWINGS.

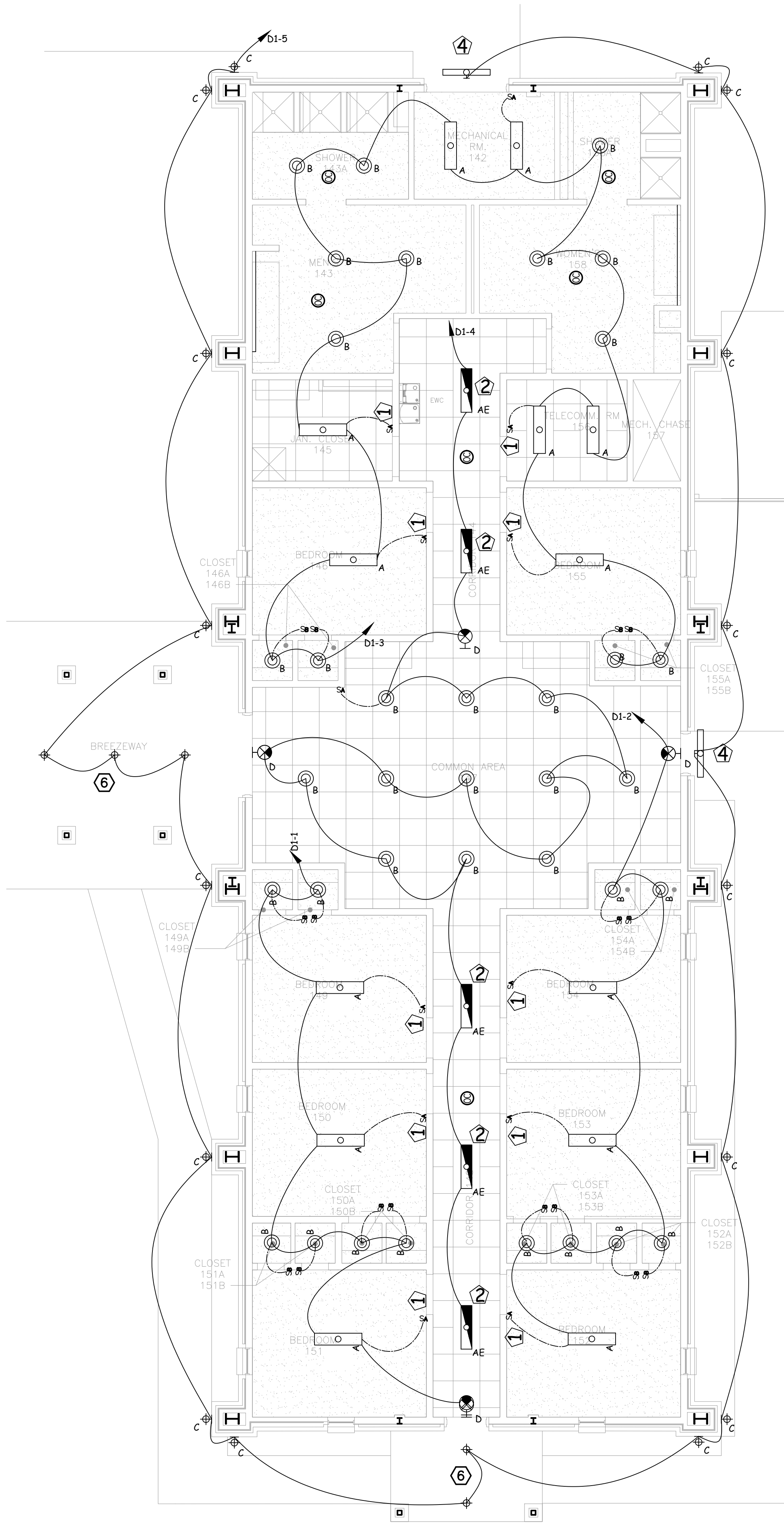

FIXTURE TYPE	MANUFACTURER MODEL #	DESCRIPTION	VOLTAGE	MOUNTING	TYPE OF LAMPS	REMARKS
			VA			
A	COOPER CRUZE ST (BAA-24C22-30-UNV-L840-CD-1-U)	2X4 LED TROFFER	120/277V 3000 LUMENS	SUSP. CLG. DROP IN	LED 4000K	
AE	COOPER CRUZE ST (BAA-24C22-30-UNV-EL14W-L840-CD-1-U)	2X2 LED TROFFER (EMERGENCY)	120/277V 3000 LUMENS	SUSP. CLG. DROP IN	LED 4000K	
B	COOPER PORTFOLIO (BAA-LD6C-10-90-40-D010-B26-M-1-H)	6" RECESSED CAN LIGHTING	120/277V 1100 LUMENS	RECESSED	LED 4000K	
C	COOPER LANERA (BAA-9002-W2-RW-LED3590-M-M-BZ-L1-UNV-WIS)	UP/DN SURFACE MOUNTED EXT. LIGHT	120/277V	WALL MOUNTED	LED	
D	COOPER SURE-LITES (CX-7-1-SD)	SURFACE MOUNTED EXIT LIGHT		SURFACE MOUNTED	LED	
E	COOPER (BAA-S123DRP-S-560D-8-40-ETT-8FO-1-UNV-D0-F-W)	ARCHITECTURAL STRIP LIGHT	120/270V 560 LMS/FT	SURFACE MOUNTED	LED 4000K	

1 LIGHTING PLAN
1/8" = 1' - 0"

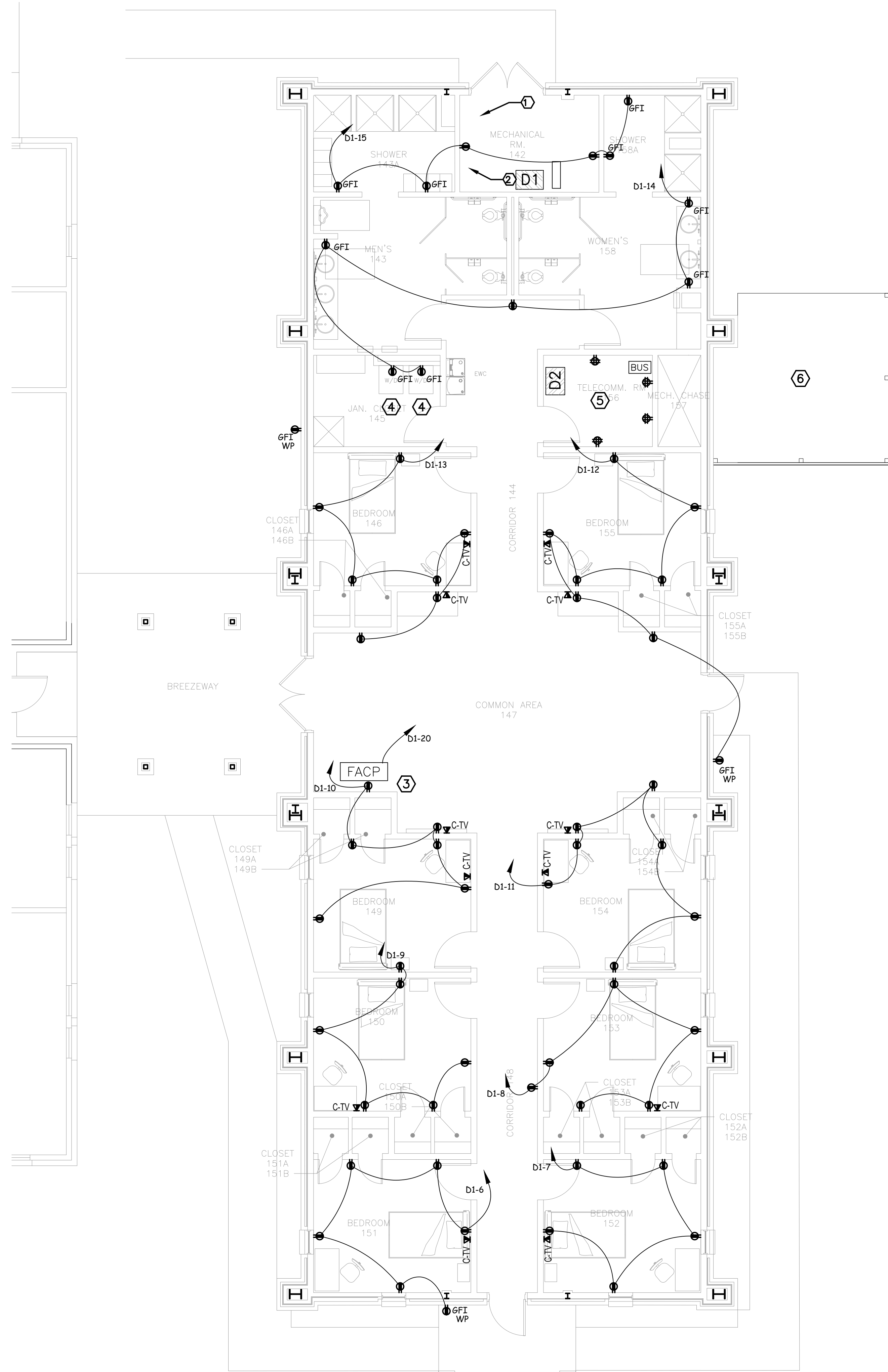

1 POWER PLAN
 $\frac{1}{16}'' = 1' - 0''$

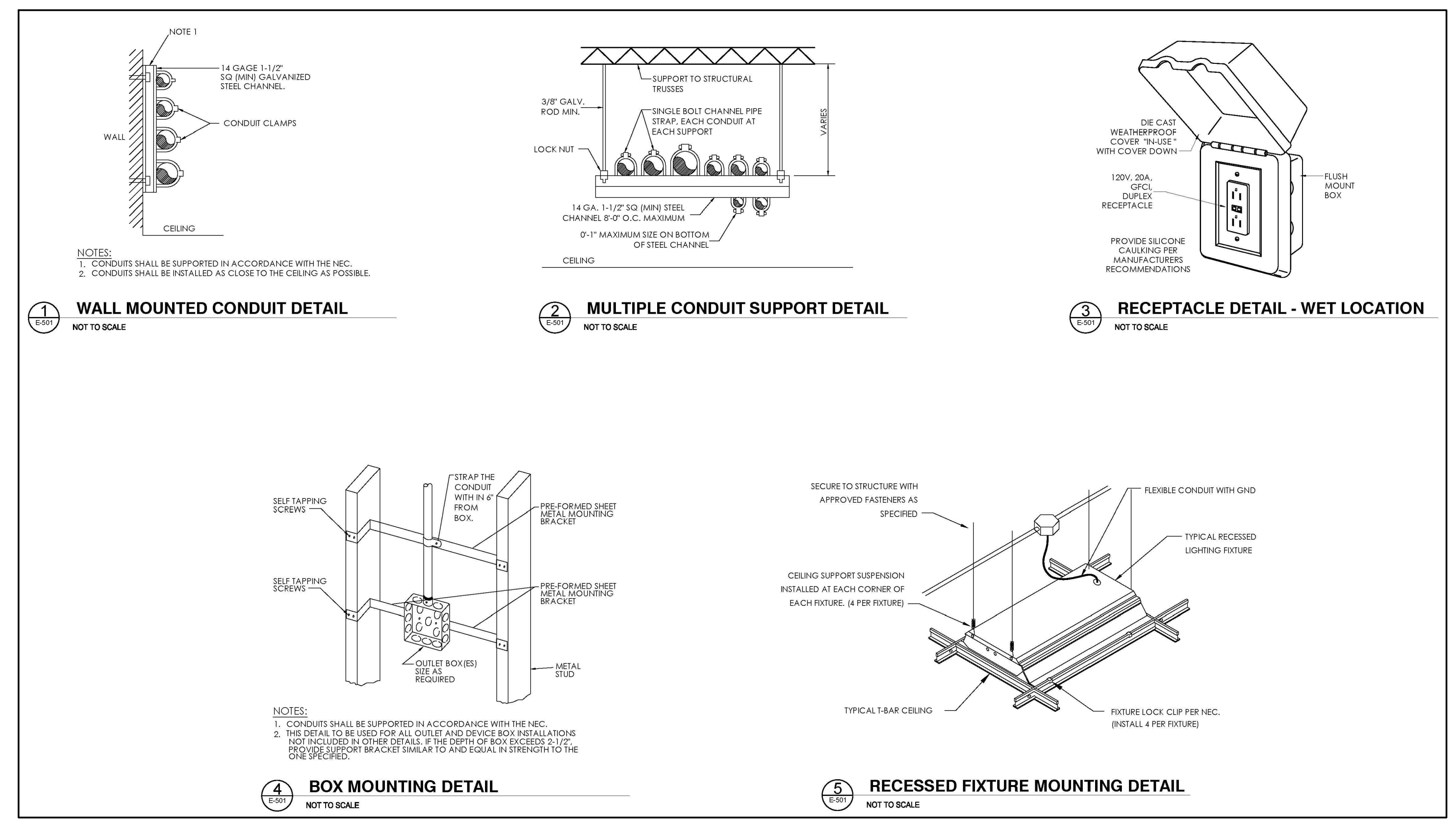

KEYNOTES

1. CONTRACTOR SHALL PROVIDE D1, ELECTRICAL PANEL. PROVIDE PANEL TYPE AND INSTALL AS SPECIFIED.
2. CONTRACTOR SHALL PROVIDE COAXIAL CABLE TV IN CONDUIT TO MECHANICAL ROOM NEW C-TV SPLITTER BOX
3. CIRCUIT BREAKER SERVING FACP CIRCUIT D1-20 SHALL HAVE AN APPROVED BREAKER LOCKING DEVICE TO COMPLY WITH NFPA 72
4. CONTRACTOR SHALL PROVIDE NEW GFCI OUTLETS, OR CIRCUITS APPROVED FOR WASHER AND DRYER USAGE.
5. CONTRACTOR SHALL PROVIDE DEDICATED ELECTRICAL PANEL FOR TELECOMMUNICATIONS ROOM IN ACCORDANCE WITH UFC 3-580-01 AND TIA-569-C. REFER TO DIVISION 27 "STATEMENT OF OBJECTIVES (SOO)" FOR ADDITIONAL INFORMATION.
6. CONTRACTOR SHALL PROVIDE NEW ELECTRICAL DISCONNECT AND DEDICATED CIRCUIT FOR NEW PACKAGED UNIT AND TELECOMMUNICATIONS ROOM FAN COIL UNIT.

GENERAL NOTES

1. THESE WORK PLANS ARE ONLY MEANT TO CONVEY THE SCOPE OF WORK FOR CONTRACTOR BIDDING AND REFERENCE PURPOSES ONLY. THE CONTRACTOR SHALL BE RESPONSIBLE FOR PROVIDING ALL NECESSARY PLANS, DRAWINGS, LINE DIAGRAMS, PANEL AND LOAD CALCULATIONS BEARING THE SEAL OF AN ELECTRICAL ENGINEER TO ENSURE THE COMPLETE INSTALLATION OF ALL NECESSARY ELECTRICAL SYSTEMS IN THE NEW ADDITION AND BID OPTION AREAS, IF AWARDED.
2. CONTRACTOR SHALL BE RESPONSIBLE FOR VERIFYING EXISTING CONDITIONS, EQUIPMENT, CURRENT PANEL CAPACITY, NEW LOAD REQUIREMENTS, AND DIMENSIONS PRIOR TO START OF WORK.
3. THE CONTRACTOR SHALL COORDINATE HIS/HER WORK WITH THAT OF ALL OTHER TRADES, INCLUDING BUT NOT LIMITED TO, ELECTRICAL, HVAC, STRUCTURAL AND GENERAL ARCHITECTURE.
4. EXISTING OUTLETS AND RECEPTACLES IN BID OPTION ROOMS ARE TO REMAIN UNLESS NOTED OTHERWISE.
5. THE GOVERNMENT HAS CONFIRMED WITH AEP, AS THE PRIMARY ELECTRICAL SERVICE PROVIDER, THAT A NEW, AND OR, UPSIZED TRANSFORMER WILL NOT BE REQUIRED TO PERFORM THE DESCRIBED IN THESE DRAWINGS.
6. CONTRACTOR SHALL PERFORM ALL ELECTRICAL WORK ACCORDING NEC AND UFC STANDARDS.
7. THE CONTRACTOR SHALL PROVIDE GROUND CONDUCTOR FOR ALL CIRCUITS
8. ALL CONDUCTORS SHALL BE IN CONCEALED EMT CONDUITS IN WALLS OR ABOVE CEILING FOR INTERIOR APPLICATIONS AND IMC CONDUITS FOR EXTERIOR APPLICATIONS UNLESS NOTED OTHERWISE
9. MINIMUM CONDUCTOR SIZE ALLOWED IS #12 COPPER

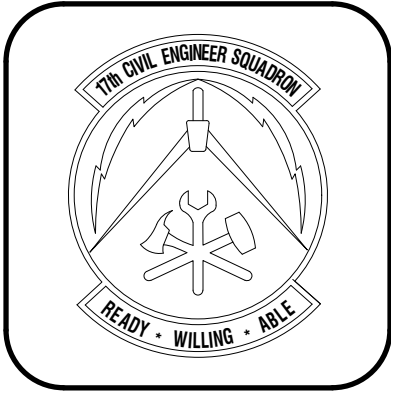

--	--	--	--	--	--	--	--	--	--

Designed by J.H.R.M.L.A.	Drawn by J.H.R.M.L.A.	Reviewed by R.T./J.H.	Submitted by P.C.B.S.
-----------------------------	--------------------------	--------------------------	--------------------------

PROJECT TITLE
FIRE STATION ADD/ALTER, B3321
PROJECT NO. 1039839
17th TRAINING WING
GOODFELLOW AIR FORCE BASE, TEXAS

Project Number: 1039839
SHEET TITLE POWER PLAN
Date: SEP 2023

SEQ.	SHEET	OF
42	E-301	50

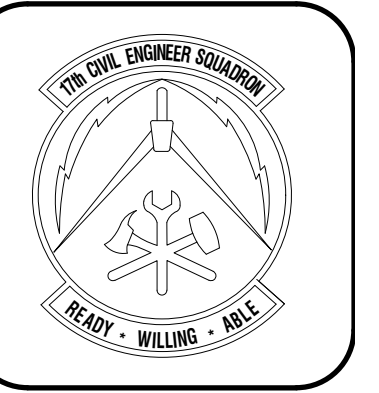

Designed by JH/MLA
Drawn by JH/MLA
Reviewed by RT/JH
Submitted by PC/S

PROJECT TITLE
**FIRE STATION ADD/ALTER, B3321
PROJECT NO. 1039839
17th TRAINING WING
GOODFELLOW AIR FORCE BASE, TEXAS**

Project Number: 1039839
SHEET TITLE PA SYSTEM PLAN
Date: SEP 2023

SEQ. 43	SHEET E-401	OF 50
------------	-----------------------	----------

KEYNOTES AS INDICATED BY ☒

1. OUTDOOR SPEAKERS SHALL BE RATED FOR OUTDOOR USE.

GENERAL NOTES

1. CONTRACTOR SHALL PROVIDE DEDICATED ALERT SPEAKER WITH A SOFT-START AUDIO OUTPUT CONTROLLABLE FROM THE DISPATCH AND TIED INTO THE FIREFIGHTING ALERT SYSTEM/AMPLIFIER. CONTRACTOR SHALL TIE SPEAKERS TO ANY EXISTING ZONE IN THE PA/AMPLIFIER SYSTEM. SEE E-101
2. CONTRACTOR SHALL DO ALL ELECTRICAL INSTALLATION ACCORDING NEC AND UFC
3. ALL CONDUCTORS SHALL BE IN CONCEALED EMT CONDUITS IN WALLS OR ABOVE CEILING FOR INTERIOR APPLICATIONS AND IMC CONDUITS FOR EXTERIOR APPLICATIONS UNLESS NOTED OTHERWISE
4. MINIMUM CONDUCTOR SIZE ALLOWED IS #12 COPPER
5. CONTRACTOR SHALL PROVIDE ALL REQUIRED EQUIPMENTS TO PERFORM THIS JOB ACCORDING INDUSTRY STANDARDS AND AS DESCRIBED EVEN IF ALL EQUIPMENT IS NOT LISTED ON THESE DRAWINGS.

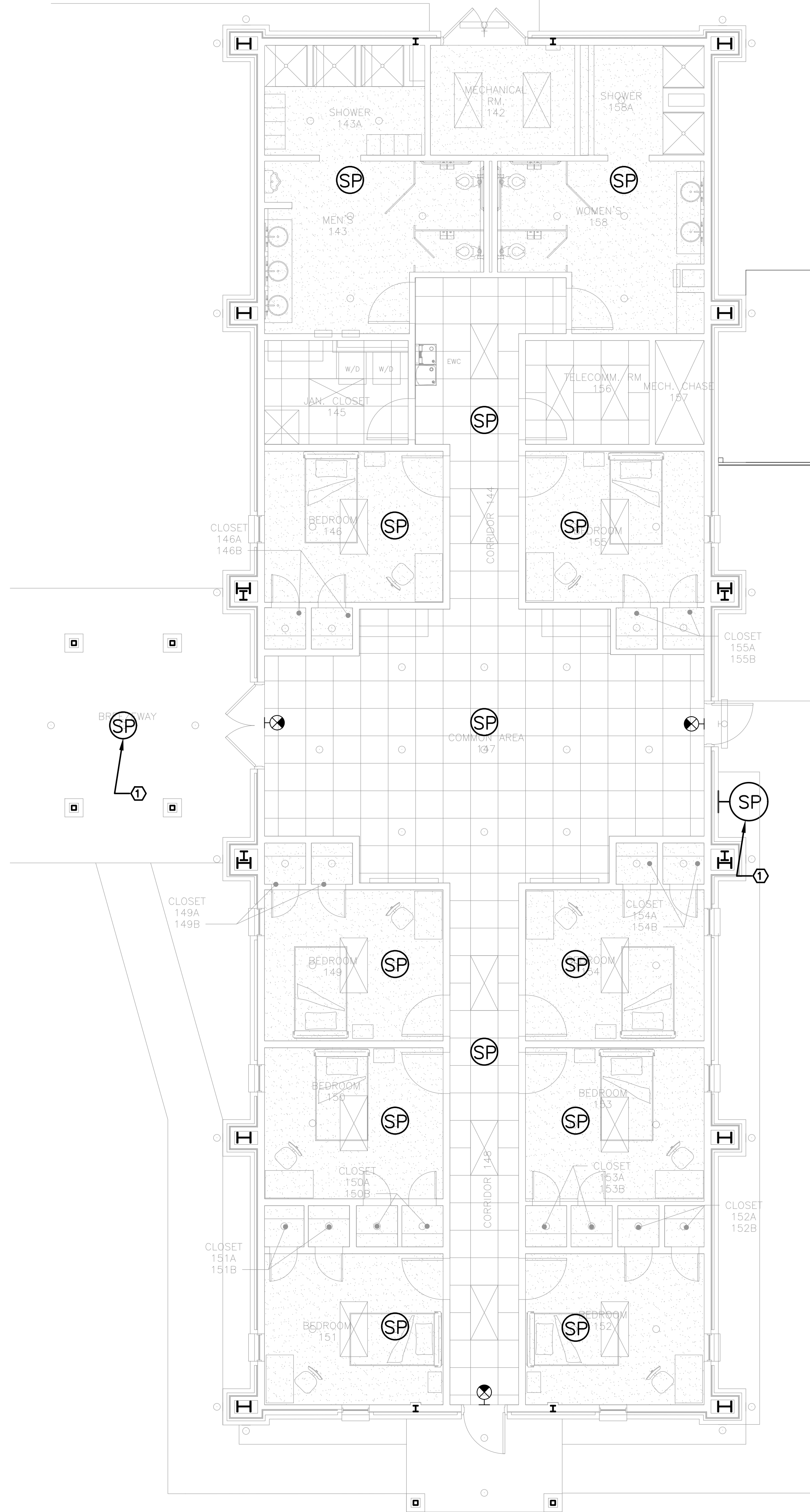

1 PA SYSTEM PLAN
1/8" = 1' - 0"

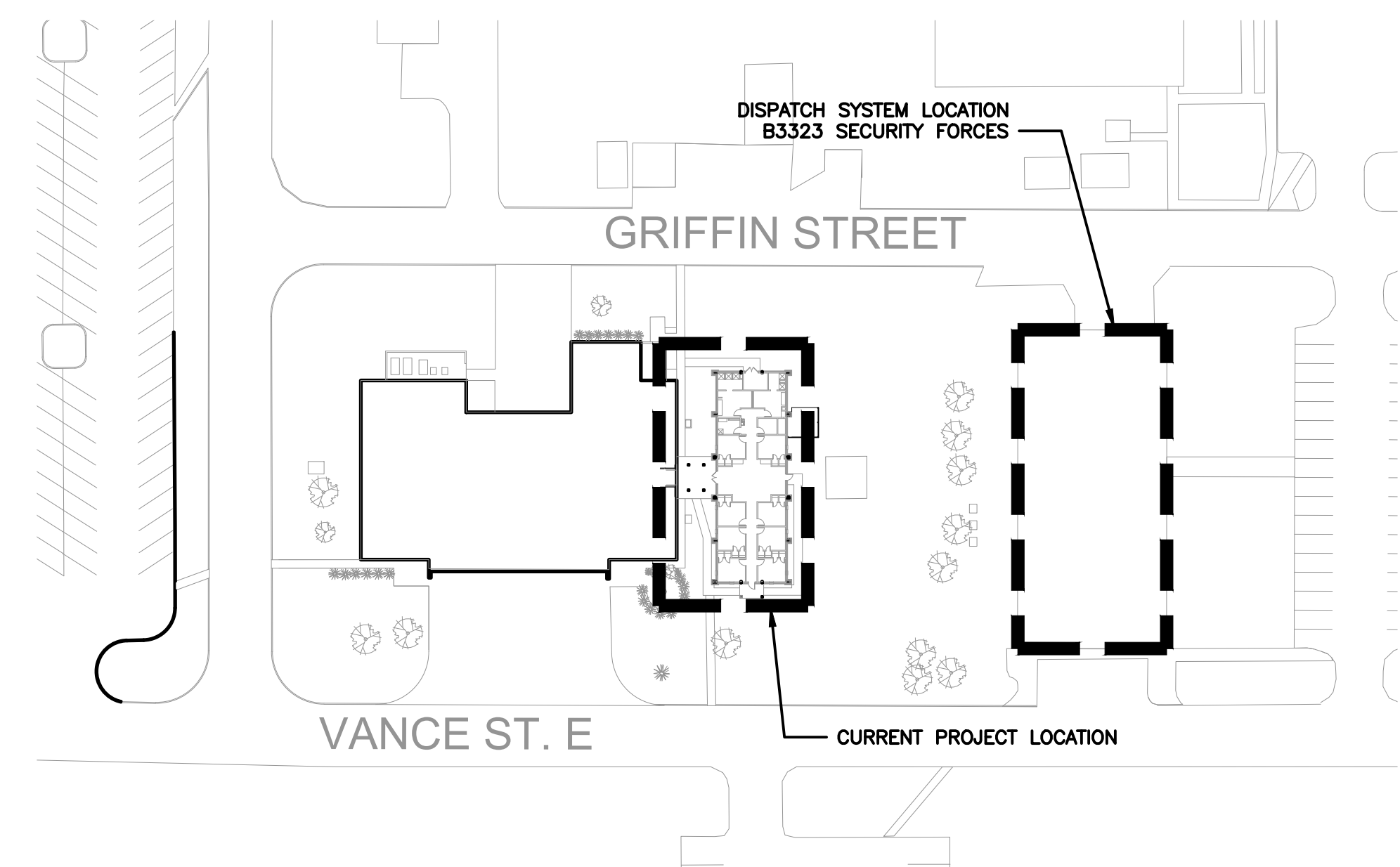

KEY PLAN
1/8" = 1' - 0"

FIRE STATION PANEL SCHEDULES
CONTRACTOR TO VERIFY

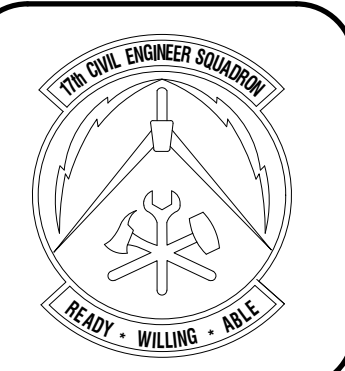

120 / 208 VOLT 3Ø, 4W 600A MLO PANEL MDP SURFACE MOUNT														
CIRC. NO.	TRIP AMPS	NO. POLES	LOAD SERVED	PHASE LOAD VA			LOAD SERVED	CIRC. NO.	TRIP AMPS	NO. POLES	LOAD SERVED			
				A	B	C								
1	-	-	////	2,800	4,433	////	2	-	-	////	2	-	-	
3	45	3	COND UNIT 1	2,800	4,433	2,800	COND UNIT 2	4	70	3	////	4	70	3
5	-	-	////	2,800	4,433	2,800	////	6	-	-	////	6	-	-
7	-	-	////	1,814	722	1,814	////	8	-	-	////	8	-	-
9	25	3	AIR COMPRESSOR	1,814	722	1,814	FURNACE 2	10	20	3	////	10	20	3
11	-	-	////	1,814	722	1,814	////	12	-	-	////	12	-	-
13	-	-	////	9,211	10,376	9,211	////	14	-	-	////	14	-	-
15	100	3	EMERGENCY ATC	9,211	10,376	9,211	PANEL G1	16	100	3	////	16	100	3
17	-	-	////	9,211	10,376	9,211	////	18	-	-	////	18	-	-
19	-	-	////	9,023	8,515	9,023	////	20	-	-	////	20	-	-
21	100	3	PANEL L1	9,023	8,515	9,023	PANEL P1	22	100	3	////	22	100	3
23	-	-	////	9,023	8,515	9,023	////	24	-	-	////	24	-	-
25	-	-	////	16,965	16,965	16,965	SPACE	26	-	-	////	26	-	-
27	200	3	PANEL D1	16,965	16,965	16,965	SPACE	28	-	-	////	28	-	-
29	-	-	////	16,965	16,965	16,965	SPACE	30	-	-	////	30	-	-
TOTAL				63,659	63,659	63,659	HIGHEST TOTAL AMPS					531	AMPS	

TOTAL = NON-CONT VA + 1.25*CONT VA

120 / 208 VOLT 3Ø, 4W 100A MCB PANEL C1 FLUSH MOUNT														
CIRC. NO.	TRIP AMPS	NO. POLES	LOAD SERVED	PHASE LOAD VA			LOAD SERVED	CIRC. NO.	TRIP AMPS	NO. POLES	LOAD SERVED			
				A	B	C								
1	20	1	TELEPHONE BOARD	360	500	360	FIRE ALARM	2	20	1	////	2	20	1
3	20	1	RADIO	500	500	500	PA SYSTEM	4	20	1	////	4	20	1
5	20	1	BASE FIRE ALARM	500	500	500	BASE FIRE ALARM	6	20	1	////	6	20	1
7	20	1	BASE FIRE ALARM	500	500	500	BASE FIRE ALARM	8	20	1	////	8	20	1
9	20	1	BASE FIRE ALARM	500	500	500	RECEPTACLES	10	20	1	////	10	20	1
11	20	1	RECEPTACLES	540	720	540	CONTROL POWER	12	20	1	////	12	20	1
13	20	1	SPARE	180	180	180	SPARE	14	20	1	////	14	20	1
15	20	1	SPARE	180	180	180	SPARE	16	20	1	////	16	20	1
17	20	1	SPARE	180	180	180	SPARE	18	20	1	////	18	20	1
19	-	-	SPACE	-	-	-	SPACE	20	-	-	////	20	-	-
21	-	-	SPACE	-	-	-	SPACE	22	-	-	////	22	-	-
23	-	-	SPACE	-	-	-	SPACE	24	-	-	////	24	-	-
25	-	-	SPACE	-	-	-	SPACE	26	-	-	////	26	-	-
27	-	-	SPACE	-	-	-	SPACE	28	-	-	////	28	-	-
29	-	-	SPACE	-	-	-	SPACE	30	-	-	////	30	-	-
TOTAL				2,325	2,415	2,095	HIGHEST TOTAL AMPS					20	AMPS	

TOTAL = NON-CONT VA + 1.25*CONT VA

120 / 208 VOLT 3Ø, 4W 225A MLO PANEL L1 SURFACE MOUNT														
CIRC. NO.	TRIP AMPS	NO. POLES	LOAD SERVED	PHASE LOAD VA			LOAD SERVED	CIRC. NO.	TRIP AMPS	NO. POLES	LOAD SERVED			
				A	B	C								
1	20	1	PARKING LOT LTS	1160	1,860	1160	APRON LIGHTS	2	20	1	////	2	20	1
3	20	1	EXTERIOR LIGHTS	400	550	400	EXTERIOR LIGHTS	4	20	1	////	4	20	1
5	20	1	PATIO LIGHTS	770	1,050	770	DORM LIGHTS	6	20	1	////	6	20	1
7	20	1	SPARE	910	1,050	910	WEST LIGHTS	8	20	1	////	8	20	1
9	20	1	KITCHEN LIGHTS	980	1,460	980	EAST LIGHTS	10	20	1	////	10	20	1
11	20	1	EAST HALL LTS	1,120	1,460	1,120	OFFICE LIGHTS	12	20	1	////	12	20	1
13	20	1	WEST EWC	500	1,080	500	GARAGE LIGHTS	14	20	1	////	14	20	1
15	20	1	WEST RECPTLS	900	1,080	900	GARAGE LIGHTS	16	20	1	////	16	20	1
17	20	1	WEST RECPTLS	900	1,080	900	GARAGE LIGHTS	18	20	1	////	18	20	1
19	20	1	DORM BED LIGHTS	400	720	400	WEST RECPTLS	20	20	1	////	20	20	1
21	20	1	WEST RECPTLS	380	540	380	WEST RECPTLS	22	20	1	////	22	20	1
23	20	1	WEST RECPTLS	720	540	720	WEST RECPTLS	24	20	1	////	24	20	1
25	20	1	DORM BED LIGHTS	400	720	400	WEST RECPTLS	26	20	1	////	26	20	1
27	20	1	DORM BED LIGHTS	900	360	900	WEST RECPTLS	28	20	1	////	28	20	1
29	20	1	WEST RECPTLS	380	360	380	DORM BED LIGHTS	30	20	1	////	30	20	1
31	20	1	SPARE	180	180	180	SPARE	32	20	1	////	32	20	1
33	20	1	CLIN 002-DORM LIGHTS	320	180	320	CLIN 003-LIGHTS/RECPTLS	34	20	1	////	34	20	1
35	20	1	SPARE	180	180	180	CLIN 003-LIGHTS/RECPTLS	36	20	1	////	36	20	1
37	-	-	SPACE	-	-	-	SPACE	38	-	-	////	38	-	-
39	-	-	SPACE	-	-	-	SPACE	40	-	-	////	40	-	-
41	-	-	SPACE	-	-	-	SPACE	42	-	-	////	42	-	-
TOTAL				9,023	8,608	8,210	HIGHEST TOTAL AMPS					75	AMPS	

TOTAL = NON-CONT VA + 1.25*CONT VA

120 / 208 VOLT 3Ø, 4W 100A MCB PANEL E1 SURFACE MOUNT														
CIRC. NO.	TRIP AMPS	NO. POLES	LOAD SERVED	PHASE LOAD VA			LOAD SERVED	CIRC. NO.	TRIP AMPS	NO. POLES	LOAD SERVED			
				A	B	C								
1	20	1	EXIT SIGNS	387	700	387	DORM LIGHTS	2	20	1	////	2	20	1
3	20	1	WEST LIGHTS	700	560	700	NIGHT LIGHTS	4	20	1	////	4	20	1
5	20	1	GARAGE LIGHTS	1,080	1,470	1,080	EAST LIGHTS	6	20	1	////	6	20	1
7	20	1	GARAGE LIGHTS	1,000	1,470	1,000	TRAFFIC SIGNAL	8	20	1	////	8	20	1
9	20	1	DOOR OPENER	902	902	902	DOOR OPENER	10	20	1	////	10	20	1
11	20	1	DOOR OPENER	902	902	902	DOOR OPENER	12	20	1	////	12	20	1
13	20	1	DOOR OPENER	902	902	902	RECEPTACLES	14	20	1	////	14	20	1
15	20	1	DROP LIGHTS	380	560	380	RECEPTACLES	16	20	1	////	16	20	1
17	20	1	RECEPTACLES	720	540	720	COND UNIT 3	18	25	2	////	18	25	2
19	20	1	FURN 3	662	1,350	662	////	20	-	-	////	20	-	-
21	20	1	KITCHEN RECPTL	500	180	500	SPARE	22	20	1	////	22	20	1
23	20	1	SPARE	180	180	180	SPARE	24	20	1	////	24	20	1
25	20	1	SPARE	180	180	180	SPARE	26	20	1	////	26	20	1
27	20	1	SPARE	180	180	180	SPARE	28	-	-	////	28	-	-
29	-	-	SPACE	-	-	-	SPACE	30	-	-	////	30	-	-
31	-	-	SPACE	-	-	-	SPACE	32	-	-	////	32	-	-
33	-	-	SPACE	-	-	-	SPACE	34	-	-	////	34	-	-
35	-	-	SPACE	-	-	-	SPACE	36	-	-	////	36	-	-
37	-	-	SPACE	-	-	-	SPACE	38	-	-	////	38	-	-
39	-	-	SPACE	-	-	-	SPACE	40	-	-	////	40	-	-
41	-	-	SPACE	-	-	-	SPACE	42	-	-	////	42	-	-
TOTAL				6,886	5,299	6,882	HIGHEST TOTAL AMPS					57	AMPS	

TOTAL = NON-CONT VA + 1.25*CONT VA

120 / 208 VOLT 3Ø, 4W 225A MLO PANEL P1 SURFACE MOUNT														
CIRC. NO.	TRIP AMPS	NO. POLES	LOAD SERVED	PHASE LOAD VA			LOAD SERVED	CIRC. NO.	TRIP AMPS	NO. POLES	LOAD SERVED			
				A	B	C								
1	20	1	WEST EXHAUST	560	1,270	560	FURNACE 1	2	20	1	////	2	20	1
3	20	1	WH RECIRC PUMP	100	400	100	EAST EXHAUST	4	20	1	////	4	20	1
5	20	1	COMPUTER RECPTL	360	720	360	EAST RECPTLS	6	20	1	////	6	20	1
7	20	1	EAST RECPTLS	900	720	900	EAST RECPTLS	8	20	1	////	8	20	1
9	20	1	EAST RECPTLS	720	720	720	EAST EWC	10	20	1	////	10	20	1
11	20	1	EAST RECPTLS	900	720	900	EAST RECPTLS	12	20	1	////	12	20	1
13	20	1	EAST RECPTLS	720	720	720	COMPUTER RECPTL	14	20	1	////	14	20	1
15	20	1	DORM BED LIGHT	360	400	360	EAST RECPTLS	16	20	1	////	16	20	1
17	20	1	EAST RECPTLS	900	720	900	EAST RECPTLS	18	20	1	////	18	20	1
19	20	1	REFRIGERATOR	500	720	500	REFRIGERATOR	20	20	1	////	20	20	1
21	20	1	KITCHEN RECPTLS	500	360	500	DISPOSAL	22	20	1	////	22	20	1
23	20	1	KITCHEN RECPTLS	500	902	500	DISHWASHER	24	25	2	////	24	25	2
25	20	1	KITCHEN EXHAUST	500	2,080	500	////	26	-	-	////	26	-	-
27	20	1	KITCHEN RECPTLS	180	180	180	////	28	20	1	////	28	20	1
29	20	1	SPARE	180	180	180	SPARE	30	20	1	////	30	20	1
31	-	-	SPACE	-	-	-	SPACE	32	20	1	////	32	20	1
33	20	2	CLIN 003 SPLIT SYSTEM	1,920	-	1,920	SPACE	34	-	-	////	34	-	-
35	-	-	SPACE	-	-	-	SPACE	36	-	-	////	36	-	-
37	-	-	SPACE	-	-	-	SPACE	38	-	-	////	38	-	-
39	-	-	SPACE	-	-	-	SPACE	40	-	-	////	40	-	-
41	-	-	SPACE	-	-	-	SPACE	42	-	-	////	42	-	-
TOTAL				8,515	6,762	8,950	HIGHEST TOTAL AMPS					76	AMPS	

TOTAL = NON-CONT VA + 1.25*CONT VA

120 / 208 VOLT 3Ø, 4W 100A MCB PANEL G1 FLUSH MOUNT														
CIRC. NO.	TRIP AMPS	NO. POLES	LOAD SERVED	PHASE LOAD VA			LOAD SERVED	CIRC. NO.	TRIP AMPS	NO. POLES	LOAD SERVED			
				A	B	C								
1	-	-	////	4,453	2,392	4,453	HOSE DRYER	2	30	2	////	2	30	2
3	70	3	SCBA AIR COMP	4,453	2,392	4,453	////	4	-	-	////	4	-	-
5	-	-	////	534	400	534	ROOM EXHAUST	6	20	1	////			

PLUMBING SYMBOLS AND ABBREVIATIONS (NOT ALL APPLY)

STANDARD SYMBOLS		ABBREVIATIONS	
SYMBOL	DESCRIPTION	SYMBOL	DESCRIPTION
PIPING-PLUMBING			
	COLD WATER		ELBOW, TURNED DOWN
	HOT WATER		ELBOW, TURNED UP
	HOT WATER RETURN		AIR VENT
	WATER		VACUUM RELIEF
	NON POTABLE WATER		TEE, TURNED UP
	SANITARY SEWER		TEE, TURNED DOWN
	VENT		VALVE IN RISER
	GRAVITY DRAIN		VALVE ON ELBOW UP
	PRESSURE DRAIN		VALVE ON ELBOW DOWN
	ACID WASTE, GRAVITY		45 ELBOW
	ACID VENT		30 ELBOW
	ACID DRAIN, PUMPED		90 ELBOW
	RAIN WATER LEADER		TEE (SHOW SIZES WHEN REDUCING TEE)
	OVERFLOW RAIN WATER LEADER		CAP
	STORM SEWER		RUPTURE DISK
	SOFT WATER		SEALED AIR CHAMBER SHOCK ABSORBER
PIPING-GASES			
	ARGON		FLOOR SINK
	BREATHING AIR		EXPANSION JOINT
	COMPRESSED AIR		LINE STRAINER
	CLEAN DRY AIR		CLEAN-OUT TO GRADE
	METHANE		OPEN SIGHT DRAIN, AIR GAP
	ACETYLENE		WALL CLEANOUT (WCO)
	CARBON DIOXIDE		FLOOR CLEANOUT (FCO)
	NATURAL GAS		DIRECTION AND FLOW
	HYDROGEN		PRESSURE GAUGE
	HOUSE CLEANING VACUUM	VALVES	
	HELIUM		BALL VALVE
	LIQUID ARGON		GATE VALVE
	LIQUID CARBON DIOXIDE		GLOBE VALVE
	LIQUID HYDROGEN		PLUG COCK
	LIQUID NITROGEN		SWING CHECK VALVE
	LIQUID OXYGEN		SPRING CHECK VALVE
	LIQUID PETROLEUM GAS		HOSE BIBB
	NITROGEN		NEEDLE VALVE
	OXYGEN		BUTTERFLY VALVE
	MEDICAL VACUUM		BALANCING VALVE
	PROCESS VACUUM		MOTOR OPERATED GLOBE VALVE
	VACUUM		MOTOR OPERATED GATE VALVE
PIPING-FITTINGS			
	SCREWED JOINT		SOLENOID OPERATED 3-WAY VALVE
	FLANGED JOINT		SELF-CONTAINED TEMP. CONTROL VALVE
	WELDED JOINT		EXTERNAL, PRESSURE REDUCING VALVE
	UNION		INTERNAL, PRESSURE REDUCING VALVE
	CONCENTRIC REDUCER		THREE WAY VALVE, ELECTRICAL
	ECCENTRIC REDUCER		THREE WAY VALVE, MANUAL
			THREE WAY VALVE, PNEUMATIC

ABBREVIATIONS	
A.F.	ABOVE FLOOR
B.F.	BELOW FLOOR
CPT	COMPRESSION TANK
CT	COOLING TOWER
CU	CONDENSING UNIT
CW	COLD WATER
DB	DRY BULB
DIA.	DIAMETER
DIR.A.	DIRECT ACTING
DN.	DOWN
DWG.	DRAWING
EA.	EACH
EAT	ENTERING AIR TEMPERATURE
EWT	ENTERING WATER TEMPERATURE
ED	EJECTION DISCHARGE
EF	EXHAUST FAN
ESP	EXTERNAL STATIC PRESSURE
EXST	EXISTING
'F	DEGREES FAHRENHEIT
FCO	FLOOR CLEAN OUT
F.D.	FIRE DAMPER
FLR	FLOOR
FM	FAN MOTOR
FFM	FEET PER MINUTE
F.S.D.	FIRE/SMOKE DAMPER
FT	FEET, FOOT
GFE	GOVERNMENT FURNISHED EQUIPMENT
GPM	GALLONS PER MINUTE
GW	GREASE WASTE
H	HOOD
HP	HORSEPOWER
HW	HOT WATER
HWCP	HOT WATER CIRCULATION PUMP
HZ	HERTZ
IN.	INCHES
IN. WTR.	INCHES OF WATER
LOUV	LOUVER
LAT	LEAVING AIR TEMPERATURE
M.V.	MEDICAL VACUUM
MAX.	MAXIMUM
MIN.	MINIMUM
M.L.O.	MAIN LUGS ONLY
MAU	MAKE UP AIR UNIT
N	NITROGEN
NO2	NITROUS OXIDE
N.C.	NORMALLY CLOSED
N.I.C.	NOT IN CONTRACT
N.O.	NORMALLY OPEN
N.T.S.	NOT TO SCALE
O2	OXYGEN
O.A.	OUTSIDE AIR
OBDD	OPPOSED BLADE DAMPER
O.C.	ON CENTER
O.H.P.	OVERHEAD PUMP
P	PUMP
PRV	PRESSURE REDUCING VALVE
PSIG	POUNDS PER SQUARE INCH
QTY.	QUANTITY
R.A.	RETURN AIR
REQ'D	REQUIRED
REV.A.	REVERSE ACTING
RPM	REVOLUTIONS PER MINUTE
RTU	ROOF TOP UNIT
S.D.	SMOKE DAMPER
SF	SUPPLY FAN
S.P.	STATIC PRESSURE
STS	STEAM SWITCH
SWBD	SWITCHBOARD
T.C.	TIME CLOCK
TMV	THERMOSTATIC MIXING VALVE
TYPICAL	TYPICAL
UH	UNIT HEATER
VAC.	VACUUM
V.A.	VOLUME DAMPER
V.T.R.	VENT THRU ROOF
CH	CHILLER, WATER COOLED
CISP	CAST IRON SOIL PIPE
CKT	CIRCUIT
CLG.	CEILING
C.O.	CLEANOUT
CFM	CUBIC FEET PER MINUTE
UF	UNDERFLOOR
W.C.O.	WALL CLEAN OUT
WH	WATER HEATER
W.H.A.	WATER HAMMER
ARESTOR	ARESTOR
W/	WITH
W/O	WITHOUT
WP	WEATHERPROOF
A/C	ABOVE CEILING
A/C	AIR CONDITIONED
A.D.	ACCESS DOOR
A.F.F.	ABOVE FINISHED FLOOR
AHU	AIR HANDLING UNIT
AP	ACCESS PANEL
AS	AIR SEPARATOR
B	BOILER

GENERAL NOTES:

- THESE PLUMBING GENERAL NOTES APPLY TO ALL PLUMBING DRAWINGS:
- ALL PLUMBING SHALL MEET THE REQUIREMENTS OF THE INTERNATIONAL PLUMBING CODE (IPC-LATEST EDITION AT TIME OF ISSUANCE OF THE RFP) AND THE CONTRACT SPECIFICATIONS.
 - THE DIVISION 22 OPERATIONS SHALL BE SUPERVISED BY A LICENSED MASTER PLUMBER TO ASSURE THAT ALL WORK IS INSTALLED IN ACCORDANCE WITH APPLICABLE CODES AND THE CONSTRUCTION DOCUMENTS.
 - DRAWINGS ARE DIAGRAMMATIC ONLY AND SHALL NOT BE SCALED. NOT ALL ITEMS CAN BE SHOWN. CONTRACTOR SHALL DETERMINE LOCATIONS OF EXISTING SYSTEMS, CONDITIONS AND COMPONENTS IN THE FIELD.
 - CONTRACTOR SHALL DETERMINE EXACT LOCATIONS OF EXISTING UTILITIES IN THE FIELD, WHETHER OR NOT SHOWN ON DRAWINGS. EXERCISE CAUTION AND IDENTIFY LOCATIONS OF UNMARKED UTILITY LINES AS NECESSARY TO PERFORM WORK OF THIS SECTION.
 - IT SHALL BE THE RESPONSIBILITY OF THIS CONTRACTOR TO COORDINATE HIS WORK WITH THAT OF ALL OTHER TRADES, INCLUDING BUT NOT LIMITED TO, ELECTRICAL, HVAC, STRUCTURAL AND GENERAL ARCHITECTURE. CONTRACTOR SHALL ENSURE NO SANITARY SEWER PIPING IS ROUTING PARALLEL IN OR UNDER STRUCTURAL FOUNDATION BEAMS.
 - ANY INTERFERENCE SHALL BE BROUGHT TO THE ATTENTION OF THE CONSTRUCTION MANAGER AND CONTRACTING OFFICER, AND SHALL BE RESOLVED PRIOR TO THE INSTALLATION OF THE WORK INVOLVED.
 - NO WORK SHALL BE INSTALLED IN VIOLATION OF ANY GOVERNING CODES. ANY WORK SHOWN ON THE DRAWINGS WHICH IS IN VIOLATION OF SUCH CODES SHALL BE BROUGHT TO THE ATTENTION OF THE CONTRACTING OFFICER AND SHALL BE RESOLVED PRIOR TO THE INSTALLATION OF THE WORK INVOLVED.
 - ALL PIPING PENETRATING CEILINGS AND WALLS SHALL BE INSTALLED WITH CHROME (STAINLESS STEEL WHERE NOTED) PLATED ESCUTCHEONS AT THE PENETRATION. ALL PIPING PENETRATING RATED PARTITIONS SHALL BE MADE WITH AN APPROVED UL FIRESTOP SYSTEM. EXPOSED PIPING SHALL BE CHROME PLATED.
 - VERIFY PLUMBING FIXTURE SCHEDULE WITH CONTRACTING OFFICER PRIOR TO START OF CONSTRUCTION. FIXTURE SELECTIONS AND INSTALLATION SHALL MEET ALL REQUIREMENTS OF THE ARCHITECTURAL BARRIERS ACT (ABA) ACCESSIBILITY REQUIREMENTS.
 - CONTRACTOR SHALL BE RESPONSIBLE FOR REPLACING ANY EXISTING WORK DAMAGED DURING THE COURSE OF CONSTRUCTION, WITH EQUAL OR BETTER MATERIAL AND WITHOUT ADDITIONAL CHARGE.
 - ALL EQUIPMENT SHALL BE INSTALLED IN STRICT COMPLIANCE WITH MANUFACTURER'S WRITTEN INSTALLATION INSTRUCTION.
 - CONTRACTOR SHALL PROVIDE ALL MISCELLANEOUS STEEL SHAPES, HANGER RODS, STRAPS, ETC. REQUIRED FOR ALL SYSTEM INSTALLATIONS FOR A COMPLETE, FUNCTIONAL, FURTHERMORE PROVIDE ALL SEISMIC RESTRAINTS AS REQUIRED BY THE INTERNATIONAL BUILDING CODE.
 - SEAL ALL EXTERIOR WALL PENETRATIONS WEATHER TIGHT. FURNISH AND INSTALL RATED SLEEVES AT ALL FIRE WALL PENETRATIONS AND SEAL AROUND ALL PIPE WITH FIRE STOP SEALANT. COORDINATE PENETRATIONS AND FIRE STOPPING WITH THE GENERAL CONTRACTOR AND OR CONSTRUCTION MANAGER.
 - CONTRACTOR SHALL MAKE TESTS AT HIS OWN EXPENSE, AS REQUIRED BY CONTRACTING OFFICER AND/OR ANY INSPECTION DEPARTMENT. TEST SHALL BE MADE TO VERIFY WHETHER THE EXISTING PIPING/EQUIPMENT SYSTEM AND NEW PIPING SYSTEMS AND EQUIPMENT INSTALLED COMPLY WITH SPECIFICATIONS AND ARE IN PROPER WORKING ORDER.
 - IF THERE IS A DISCREPANCY BETWEEN THE SPECIFICATIONS AND DRAWINGS, THE CONTRACTOR SHALL FURNISH AND INSTALL THE GREATER VALUE AND QUALITY OF EITHER THE SPECIFICATIONS OR DRAWINGS. IN ALL CASES, THE ENGINEER OF RECORD SHALL BE THE INTERPRETER OF THE DOCUMENTS.
 - IF THERE IS A DISCREPANCY BETWEEN THE DRAWING DETAILS AND DRAWING FLOOR PLAN, THE CONTRACTOR SHALL FURNISH AND INSTALL THE GREATER VALUE AND QUALITY OF EITHER THE DETAIL OR FLOOR PLAN. IN ALL CASES, THE ENGINEER OF RECORD SHALL BE THE INTERPRETER OF THE DOCUMENTS.
 - SANITARY, SOIL WASTE AND VENT PIPING SHALL SLOPE NOT LESS THAN: 1/8" PER FOOT FOR PIPING 2 1/2" IN DIAMETER OR LESS, 1/16" PER FOOT FOR PIPING 3" TO 6" IN DIAMETER, 1/32" PER FOOT FOR PIPING 8" OR LARGER IN DIAMETER.
 - THE CONTRACTOR SHALL PROVIDE ISOLATION VALVES ON WATER PIPING TO EACH GROUP OF FIXTURES. ACCESS PANELS ARE REQUIRED IN CYP BOARD CEILINGS AND WALLS FOR ALL VALVES, TRAPS, CLEANOUTS, ETC. ACCESS PANELS SHALL BE 16 GAGE PAINTABLE STEEL CONSTRUCTION WITH A PIANO HINGED DOOR. FLANGE FRAME, WALL SLEEVE AND VANDAL PROOF SCREWS. PANELS IN EXPOSED TILE OR BLOCK ACCESS PANELS IN FIRE RATED ASSEMBLIES SHALL HAVE THE SAME RATING AS THE ASSEMBLY. STOPS ARE REQUIRED AT ALL PLUMBING FIXTURES.
 - WHERE DISSIMILAR METALS ARE TO BE JOINED AS WELL AS PIPES THAT REQUIRE SUPPORTS, APPROVED INSULATION UNIONS AND COOPER CLAD BRACKETS TO SUPPORT PIPES ARE TO BE USED.
 - INSULATE ALL HOT AND COLD WATER PIPING. INSULATION SHALL BE OF THE TYPE SPECIFIED PER SPECIFICATIONS AND MINIMUM THICKNESS SPECIFIED IN ASHRAE STANDARD 90.1 LATEST EDITION

- (AT DATE OF RFP) AND UFC CRITERIA, WHICHEVER IS GREATER. ALL INSULATION SHALL HAVE COMPLETE FIRE AND SMOKE HAZARD RATINGS. INSULATION SHALL BE A CLASS FIBERGLASS OR EQUIVALENT. MANUFACTURED BY OWNES-CORNING FIBERGLASS OR EQUIVALENT. INSULATION SHALL HAVE A MINIMUM DENSITY OF 4.0 LB AND A K FACTOR OF 0.25.
- CONTRACTOR SHALL BE RESPONSIBLE FOR ALL FIXTURE, CASEWORK AND EQUIPMENT ROUGH-IN DIMENSIONS AND CORRECT FLOOR AND WALL PENETRATIONS.
 - ALL DOMESTIC WATER PIPING SHALL BE DISINFECTED IN ACCORDANCE WITH AWWA.
 - DRAWINGS DO NOT INDICATE ALL DETAILS, FITTINGS AND EXACT LOCATION OF PIPE OR EQUIPMENT. THE CONTRACTOR SHALL PROVIDE ALL NECESSARY MATERIALS AND LABOR IN AN APPROPRIATE MANNER TO ENSURE FULLY FUNCTIONAL SYSTEMS ACCEPTABLE TO THE CO, OWNER, AUDITED AND ENGINEER.

GENERAL DEMOLITION NOTES:

- THESE PLUMBING GENERAL NOTES APPLY TO ALL PLUMBING DRAWINGS:
- PERFORM ALL DEMOLITION IN ACCORDANCE WITH SPECIFICATION SECTION 02 41 00 EXISTING CONDITIONS - DEMOLITION. WORK IS TO BE PERFORMED WITH THE GOAL OF MAXIMIZING SALVAGE AND RECYCLING OF MATERIALS.
 - COORDINATE WITH AND OBTAIN APPROVAL FROM CONTRACTING OFFICER FOR ALL UTILITY OUTAGES A MINIMUM OF 72 HOURS IN ADVANCE.
 - SECURE ALL OPENINGS THROUGH WALLS, ROOFS AND FLOORS FROM WEATHER DURING CONSTRUCTION.
 - SECURE OPENINGS THROUGH ROOFS AND FLOORS FROM FALL AND PROVIDE ALL APPROPRIATE FALL PROTECTION MEASURES PER OSHA REQUIREMENTS.
 - SALVAGE EQUIPMENT ITEMS TO A DESIGNATED STORAGE OR DISPOSAL AREA AS DIRECTED BY THE CONTRACTING OFFICER.
 - CONTRACTOR TO LOCATE ALL UNDERGROUND UTILITIES PRIOR TO START OF CONSTRUCTION AND MARK APPROPRIATELY.
 - CONTRACTOR SHALL REVIEW OWNER'S HAZARDOUS MATERIAL TEST REPORTS AND COORDINATED WORK WITH ABATEMENT CONTRACTOR(S) AS APPROPRIATE. NOTIFY CONTRACTING OFFICER AND/OR CONTRACTING OFFICER'S REPRESENTATIVE IMMEDIATELY OF ANY MATERIAL SUSPECTED OR KNOWN TO BE HAZARDOUS FOR WORK INSTRUCTIONS PRIOR TO CONTINUING OF WORK ON THAT SECTION OR AREA OF CONSTRUCTION AS APPROPRIATE.
 - PIPING UNDER CONCRETE SLAB ON GRADE FLOORS MAY BE CUT BELOW CONCRETE FLOOR, CAPPED, AND ABANDONED IN PLACE IF NOT INTERFERING WITH INSTALLATION OF NEW PIPING OR OTHER TRADES.
 - CAP ALL UNUSED PIPING BELOW GRADE. MARK ABANDONED PIPING EXTERIOR TO BUILDING WITH METALLIC BURIED WARNING TAPE 6" BELOW GRADE.
 - PLUG ALL FLOOR DRAINS TO REMAIN PRIOR TO START OF CONSTRUCTION TO PREVENT ENTRY OF DEBRIS DURING CONSTRUCTION.
 - REMOVE ALL RUBBISH AND DEBRIS CAUSED BY THE DEMOLITION WORK AND DISPOSE OF PROPERLY. CLEAN ALL RELATED EXISTING AND NEW PLUMBING FIXTURES AND EQUIPMENT AT COMPLETION OF DEMOLITION WORK.

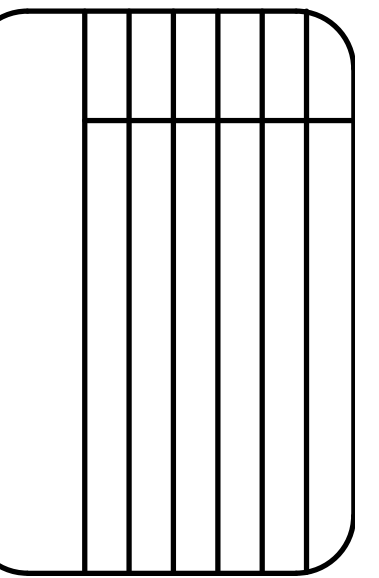
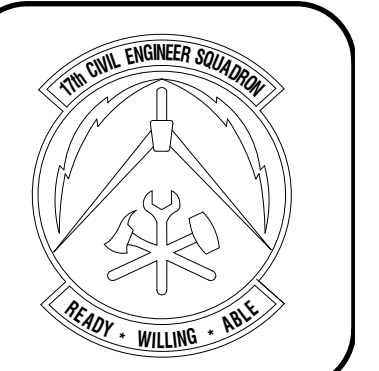

Designed by: J.H.R.L.A.
 Drawn by: J.H.R.L.A.
 Reviewed by: RTI/JH
 Submitted by: PCES

PROJECT TITLE
**FIRE STATION ADD/ALTER, B3321
 PROJECT NO. 1039839
 17th TRAINING WING
 GOODFELLOW AIR FORCE BASE, TEXAS**

Project Number:
 1039839
 SHEET TITLE
**PLUMBING NOTES SYMBOLS
 & ABBREVIATIONS**
 Date:
 SEP 2023

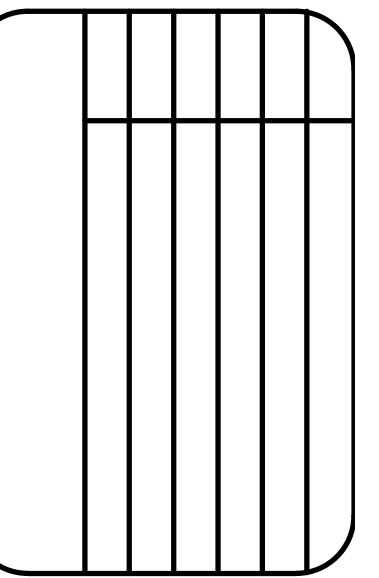
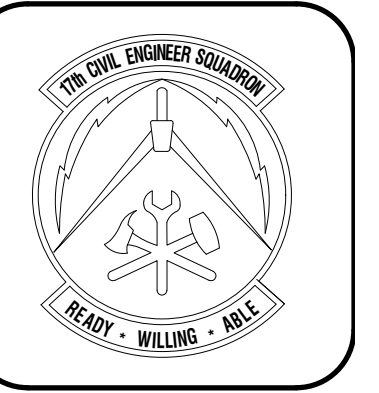

Designed by:
JHR/MLA

Drawn by:
JHR/MLA

Reviewed by:
RTI/AH

Submitted by:
PCES

PROJECT TITLE

FIRE STATION ADD/ALTER, B3321
PROJECT NO. 1039839
17th TRAINING WING
GOODFELLOW AIR FORCE BASE, TEXAS

Project Number:
1039839

SHEET TITLE
SANITARY SEWER PLAN

Date:
SEP 2023

SEQ.	SHEET	OF
46	P-101	50

GENERAL NOTES

1. REFERENCE SHEET P-001 FOR LEGEND, SYMBOLS, ABBREVIATIONS, SPECIFICATIONS AND FURTHER GENERAL NOTES.
2. ALL SANITARY SEWER PIPING SHALL BE PVC SCHEDULE 80.
3. CONTRACTOR SHALL ENSURE WASTE FROM CLOTHES SHALL DISCHARGE THROUGH AN AIR BREAK INTO A STANDPIPE.
4. AIR BREAK SHALL BE PROVIDED BETWEEN THE INDIRECT WASTE PIPE AND THE TRAP SEAL OF THE WASTE RECEPTOR.

KEYNOTES

1. SS PIPING RISE FROM BELOW FLOOR TO SERVE THE PLUMBING FIXTURE(S). REFERENCE P-301 FOR MORE INFORMATION.
2. VENT PIPING RISE FROM BELOW FLOOR TO SERVE THE PLUMBING FIXTURE(S). REFERENCE P-301 FOR MORE INFORMATION.
3. FURNISH AND INSTALL A FLOOR-MOUNTED, FLOOR OUTLET, FLUSH VALVE WATER CLOSET AND APPURTENANCES. ROUTE 4" SS PIPING FROM THE HORIZONTAL 4" SS BELOW FLOOR TO THE FIXTURE AND CONNECT, ROUTE 2" VENT PIPING FROM THE WATER CLOSETS TO HORIZONTAL VENT PIPE ABOVE. HORIZONTAL VENT PIPE FROM WATER CLOSETS SHALL BE 3", PROVIDE 4" VTR.
4. FURNISH AND INSTALL AN UNDERMOUNT LAVATORY, FAUCET, THERMOSTATIC MIXING VALVE AND APPURTENANCES. ROUTE 1 1/2" SS PIPING FROM THE LAVATORY DRAIN ROUGH-IN CONNECTION DOWN WITHIN THE WALL TO THE HORIZONTAL SS PIPING BELOW THE FLOOR AND CONNECT. ROUTE 2" VENT PIPING UP WITHIN THE WALL FROM THE SS PIPING SERVING THE LAVATORY TO ABOVE THE CEILING AND CONNECT TO THE 2" HORIZONTAL VENT PIPING ABOVE. 2" VERTICAL VENT PIPE AND 2" HORIZONTAL PIPE TO VENTS ABOVE WATER CLOSETS. FURNISH AND INSTALL THE P-TRAP AND APPURTENANCES FROM THE DRAIN TO THE LAVATORY, AND CONNECT.
5. FURNISH AND INSTALL A WALL-HUNG URINAL AND FLUSH VALVE. ROUTE A 2" SS PIPE DOWN WITHIN THE WALL FROM THE OUTLET OF THE URINAL TO THE HORIZONTAL SS PIPE BELOW THE FLOOR AND CONNECT. ROUTE A 2" VENT PIPE UP IN THE WALL FROM THE FIXTURE TO THE HORIZONTAL VENT PIPING AND CONNECT. 2" VERTICAL VENT PIPE AND 2" HORIZONTAL PIPE TO VENTS ABOVE WATER CLOSETS.
6. FURNISH AND INSTALL A SHOWER ASSEMBLY, FAUCETS, THERMOSTATIC MIXING VALVE, ACCESSORIES AND APPURTENANCES. FURNISH AND INSTALL A GRID STRAINER SHOWER DRAIN. TRAP THE DRAIN, ROUTE 1 1/2" SS PIPING BELOW FLOOR, AND CONNECT TO THE HORIZONTAL SS PIPING. ROUTE A 2" VENT UP IN THE WALL TO ABOVE THE CEILING AND CONNECT TO THE HORIZONTAL VENT PIPING.
7. FURNISH AND INSTALL A MOP BASIN, FAUCET, ACCESSORIES AND APPURTENANCES. ROUTE AND P-TRAP THE 1 1/2" SS PIPING FROM THE DRAIN OF THE MOP BASIN TO THE SS PIPING BELOW THE FLOOR AND CONNECT. ROUTE A 2" VENT UP WITHIN THE WALL TO 2" HORIZONTAL VENT ABOVE CEILING AND CONNECT TO EWC. COMBINED 2" VENT PIPE TO 2" VTR.
8. FURNISH AND INSTALL A FLOOR DRAIN WITH TRIP GUARD ASSEMBLY. ROUTE A 2" SS PIPE FROM THE FLOOR DRAIN TRAP OUTLET TO THE HORIZONTAL SS PIPING BELOW FLOOR AND CONNECT. ROUTE A 2" VENT PIPE UP IN THE WALL FROM THE FIXTURE TO THE HORIZONTAL VENT PIPING IN THE ATTIC AND CONNECT.
9. FURNISH AND INSTALL A WALL-HUNG, BI-LEVEL DRINKING FOUNTAIN WITH BOTTLE FILLER. ROUTE A 1 1/2" SS PIPE FROM THE OUTLET OF THE ELECTRIC DRINKING FOUNTAIN DOWN WITHIN THE WALL AND TO THE HORIZONTAL SS AND CONNECT. FURNISH AND INSTALL A WCO. ROUTE A 2" VENT UP WITHIN THE WALL TO THE HORIZONTAL VENT ABOVE CEILING AND CONNECT TO MOP SINK (MS-1). COMBINED 2" VENT PIPE TO 2" VTR.
10. FURNISH AND INSTALL A GAS WATER HEATER, SUPPORT PLATFORM, EXPANSION TANK, DRAIN PAN, AND APPURTENANCES. REFERENCE DETAIL 3/P-501 FOR MORE INFORMATION. ROUTE THE 3/4" T&P PIPING DOWN TO EXISTING FLOOR DRAIN, TURN DOWN AND TERMINATE.
11. FURNISH AND INSTALL ALL CLEANOUTS IN AN ACCESSIBLE LOCATION A MINIMUM OF 42" AFF. THE WALL CLEANOUT ACCESS COVER SHALL BE CONSTRUCTED OF STAINLESS STEEL.

REFER TO
C-101 FOR
EXTERIOR
CONNECTION

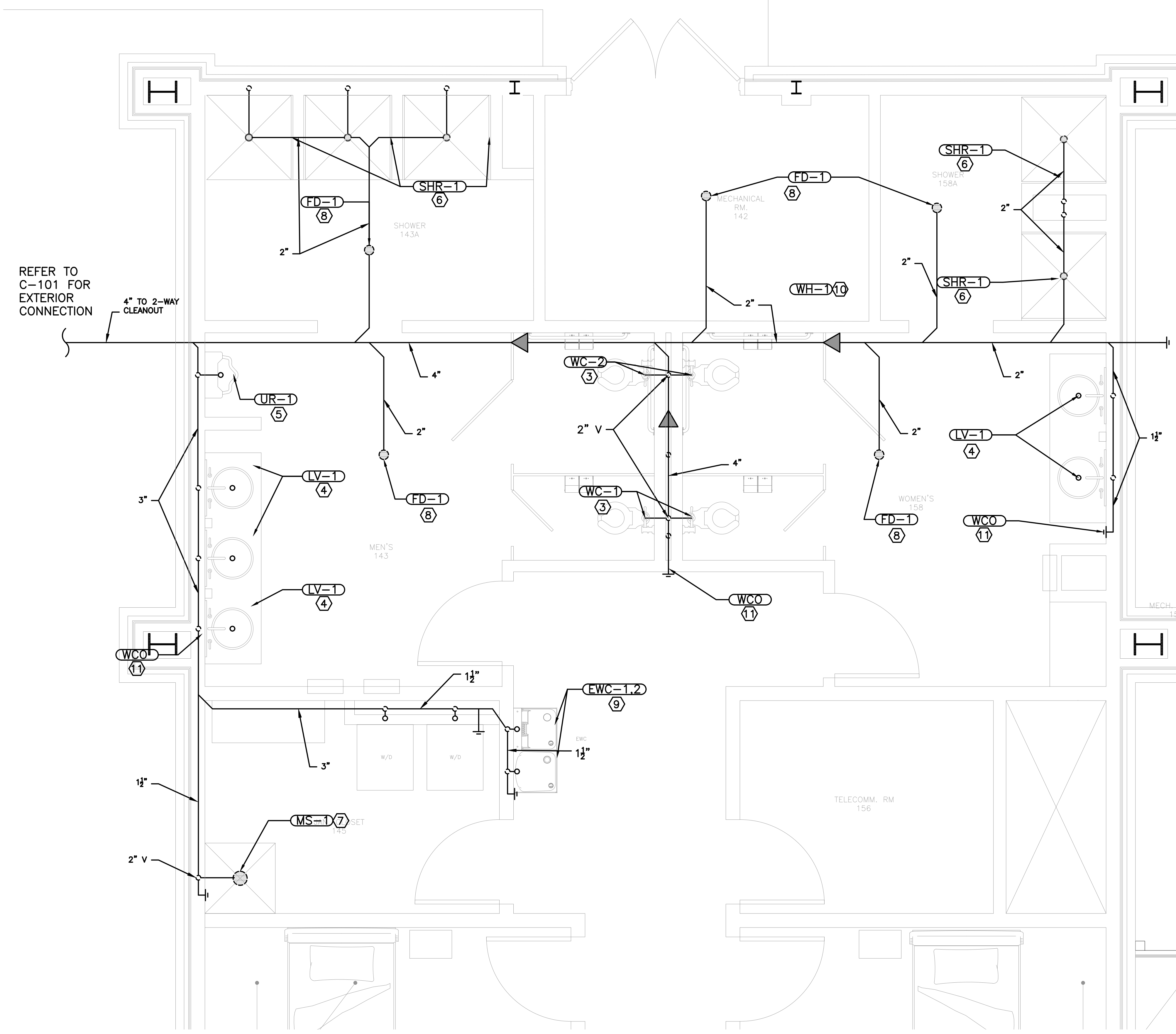

1 SANITARY SEWER PLAN

3/8" = 1' - 0"

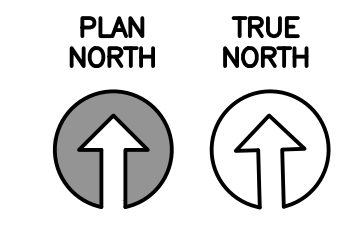

PROJECT TITLE

Project Number:

1039839

SHEET TITLE

SANITARY SEWER PLAN

Date:

SEP 2023

SEQ.

SHEET

OF

46

P-101

50

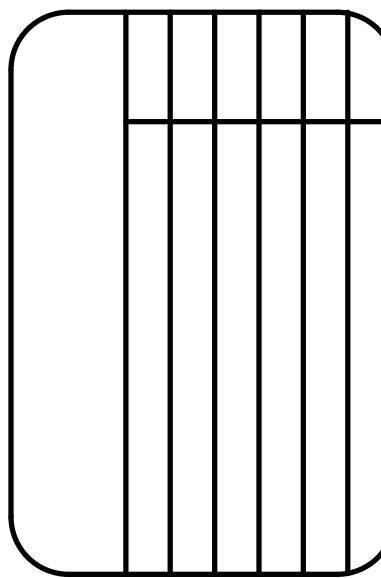

Designed by:
JHR/MLA
Drawn by:
JHR/MLA
Reviewed by:
RT/AJH
Submitted by:
TPCES

PROJECT TITLE
**FIRE STATION ADD/ALTER, B3321
PROJECT NO. 1039839
17th TRAINING WING
GOODFELLOW AIR FORCE BASE, TEXAS**

Project Number:
1039839
SHEET TITLE
SANITARY SEWER PLAN
Date:
SEP 2023

SEQ. SHEET OF
47 **P-102** 50

GENERAL NOTES

- REFERENCE SHEET P-001 FOR LEGEND, SYMBOLS, ABBREVIATIONS, SPECIFICATIONS AND FURTHER GENERAL NOTES.
- DOMESTIC PLUMBING SHALL BE (PEX) OR APPROVED EQUAL.
 - PEX PIPING SHALL BE INSTALLED ACCORDING TO THE MANUFACTURER'S RECOMMENDATIONS.
- CONTRACTOR SHALL FURNISH AND INSTALL AN ACCESS PANEL FOR ITEMS IN INACCESSIBLE LOCATIONS.
- FOR WASHER/DRYER LOCATIONS, WATER SUPPLY TO WASHER SHALL BE PROTECTED AGAINST BACKFLOW BY AN AIR GAP THAT INTEGRAL WITH THE MACHINE. (X)

KEYNOTES

- FURNISH AND INSTALL A FLOOR-MOUNTED, FLOOR OUTLET, FLUSH VALVE WATER CLOSET AND APPURTENANCES. ROUTE A 1" CW PIPING FROM THE HORIZONTAL CW PIPING ABOVE THE CEILING DOWN WITHIN THE WALL TO THE ROUGH-IN CONNECTION AT THE WALL. FURNISH AND INSTALL A SUPPLY, STOP AND APPURTENANCES FROM THE CW ROUGH-IN TO THE WATER CLOSET AND CONNECT.
- FURNISH AND INSTALL AN UNDERMOUNT LAVATORY, FAUCET, THERMOSTATIC MIXING VALVE AND APPURTENANCES. ROUTE 1/2" CW AND 1/2" HW PIPING FROM THE HORIZONTAL CW & HW PIPING ABOVE THE CEILING DOWN WITHIN THE WALL TO THE ROUGH-IN CONNECTION, TO THE THERMOSTATIC MIXING VALVE AND LAVATORY FAUCET AND CONNECT. FURNISH AND INSTALL THE SUPPLIES, STOPS, AND APPURTENANCES FROM THE CW, AND HW ROUGH-INS TO THE LAVATORY, THERMOSTATIC MIXING VALVE AND FAUCET AND CONNECT.
- FURNISH AND INSTALL A WALL-HUNG URINAL AND DFLUSH VALVE. ROUTE A 3/4" CW PIPE FROM THE HORIZONTAL CW PIPE ABOVE THE CEILING DOWN IN THE WALL TO THE INLET OF THE FLUSH VALVE AND CONNECT.
- FURNISH AND INSTALL A SHOWER ASSEMBLY, FAUCETS, THERMOSTATIC MIXING VALVE, ACCESSORIES AND APPURTENANCES. ROUTE 1/2" CW AND 1/2" HW PIPING FROM THE (PEX) MANIFOLD IN MECHANICAL ROOM, ABOVE THE CEILING DOWN WITHIN THE WALL TO THE ROUGH-IN AND CONNECT.
- FURNISH AND INSTALL A MOP BASIN, FAUCET, ACCESSORIES AND APPURTENANCES. ROUTE 3/4" CW AND 3/4" HW FROM THE CW AND HW PIPING ABOVE THE CEILING DOWN IN THE WALL TO THE FAUCET AND CONNECT.
- FURNISH AND INSTALL A WALL-HUNG, BI-LEVEL DRINKING FOUNTAIN WITH BOTTLE FILLER. ROUTE 1/2" CW PIPE FROM THE HORIZONTAL CW PIPE ABOVE THE CEILING DOWN IN THE WALL TO THE INLET OF THE ELECTRIC DRINKING FOUNTAIN AND CONNECT.
- FURNISH AND INSTALL A WATER HAMMER ARRESTOR, VALVE AND ACCESS PANEL, THE ARRESTOR SHALL BE INSTALLED WITHIN THE WALL/CHASE CAVITY. FURNISH AND INSTALL AN ACCESS PANEL AT THE INACCESSIBLE LOCATION.
- FURNISH AND INSTALL A CIRCUIT SETTER ABOVE THE CEILING. SET THE CIRCUIT SETTER TO 0.5 GPM.

FOR DOMESTIC WATER CONNECTION SEE C-101.

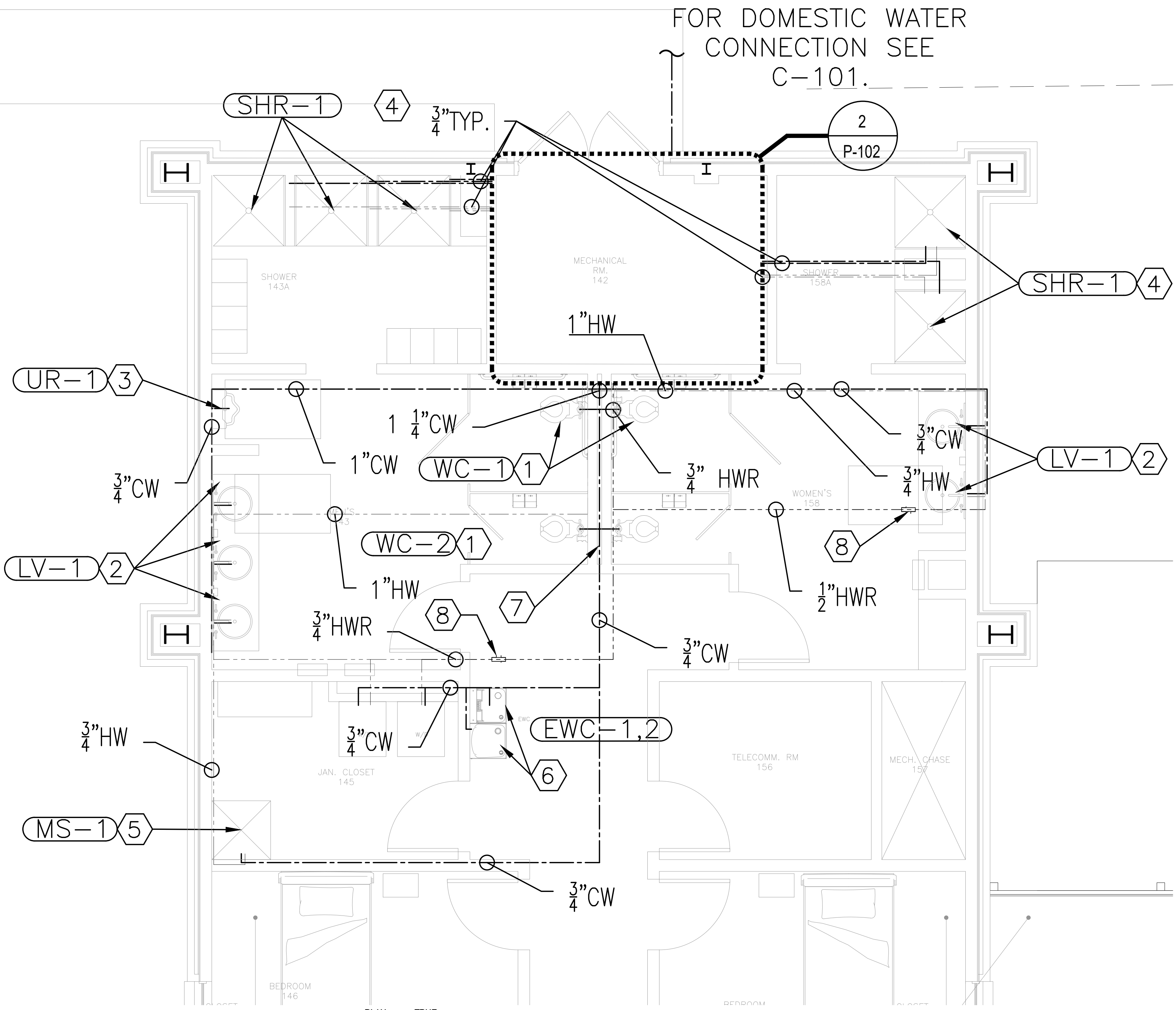

1 DOMESTIC WATER PLAN
3/4" = 1' - 0"
PLAN NORTH TRUE NORTH

ENLARGED MECH. RM. KEYNOTES (X)

- CONNECT TO EXISTING DOMESTIC WATER LINE. RE:C101
- NOT USED.
- FURNISH AND INSTALL A GAS WATER HEATER, SUPPORT PLATFORM, EXPANSION TANK, DRAIN PAN, AND APPURTENANCES, REFERENCES SHEET P-501 FOR ADDITIONAL INFORMATION. ROUTE THE 3/4" T&P PIPING DOWN TO EXISTING FLOOR DRAIN, TURN DOWN AND TERMINATE.
- FURNISH AND INSTALL GAS PIPING CONNECTION TO EQUIPMENT, REFERENCE SHEET P-501.
- FURNISH AND INSTALL A DOMESTIC HOT WATER RECIRCULATION PUMP, REFERENCE SHEET P-501.
- FURNISH AND INSTALL A DOMESTIC PLUMBING APPROVED PEX CW AND HW MANIFOLD.
- CONTRACTOR TO FURNISH AND INSTALL RECIRCULATION PUMP. MOUNT IN ACCESSIBLE LOCATION ABOVE EXPANSION TANK.
- DASHED LINE INDICATES NEW FIRE SUPPRESSION RISER ASSEMBLY AND DOUBLE CHECK BACKFLOW PREVENTER PER IPC. COORDINATE SIZE AND ASSEMBLY WITH QFPE. REFER TO FA-101.
- DOMESTIC WATER RISER AND ENTRY POINT
- CONTRACTOR TO PROVIDE NEW 1/2" EXTERIOR WALL HYDRANT AND COVERED ENCLOSURE.
- CONTRACTOR TO PROVIDE NEW WATER SERVICE ENTRANCE ISOLATION VALVE.

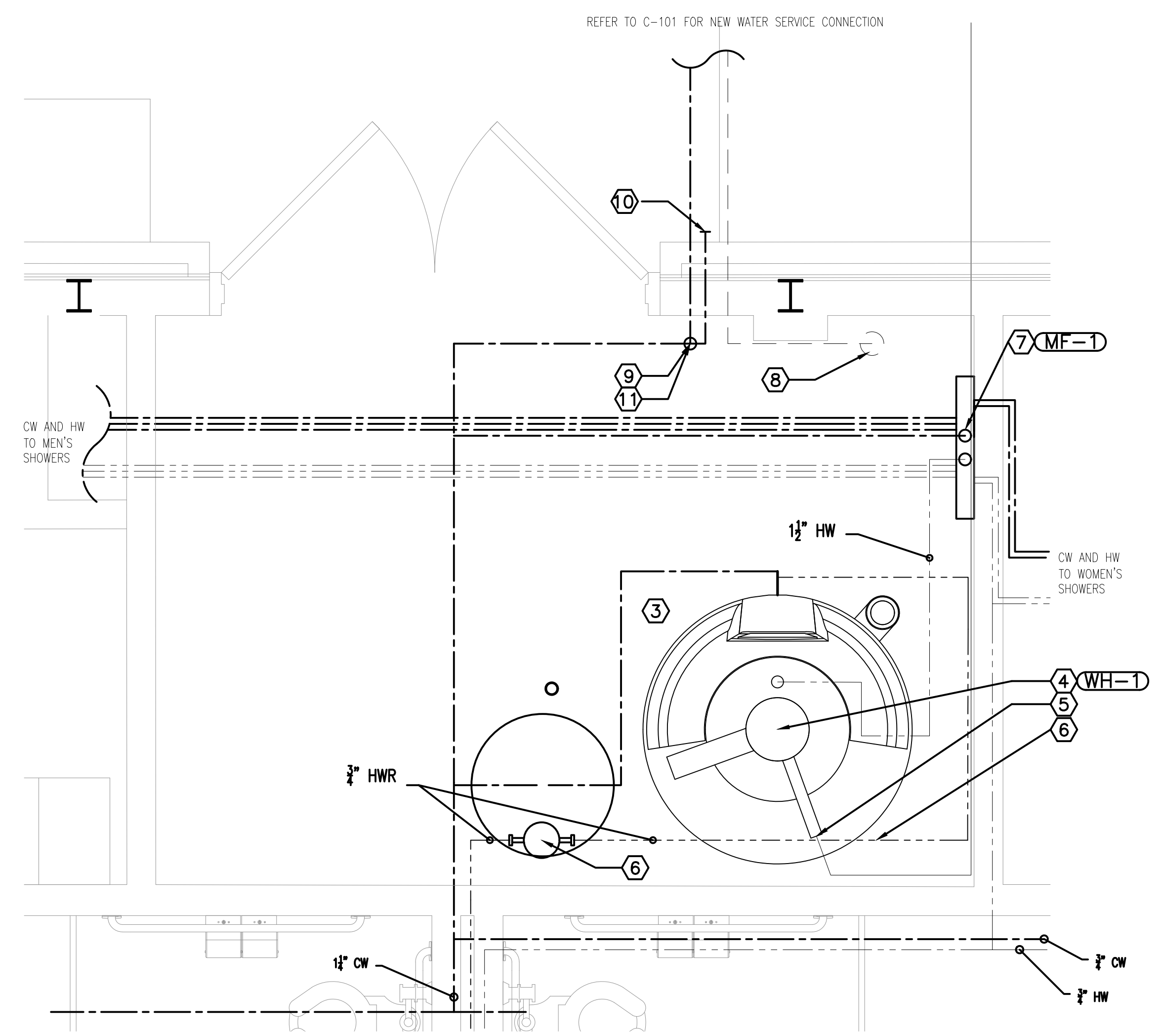

2 ENLARGED MECHANICAL ROOM PLUMBING PLAN
3/4" = 1' - 0"
PLAN NORTH TRUE NORTH

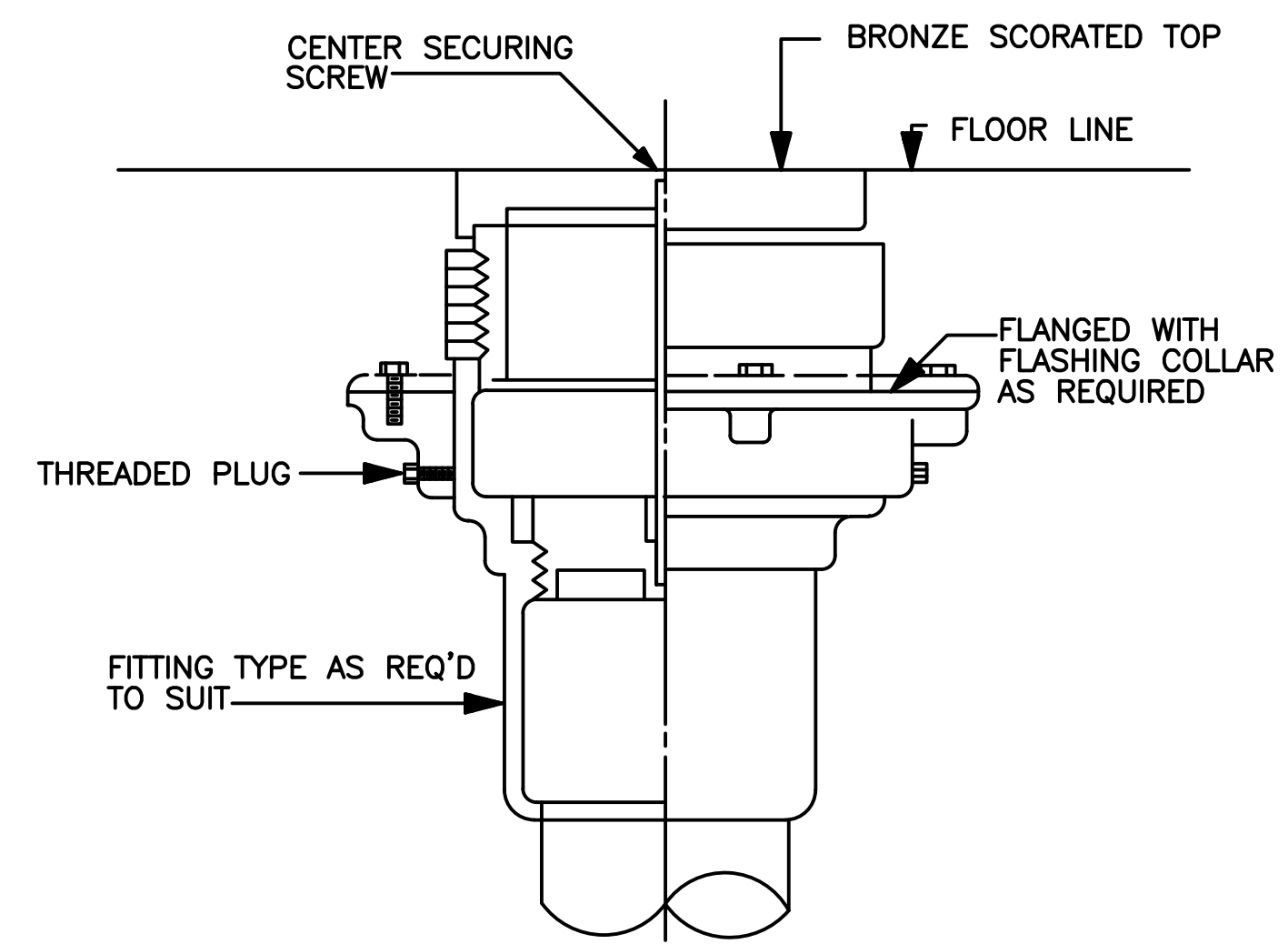

1 FLOOR DRAIN DETAIL (TYP.)
NTS

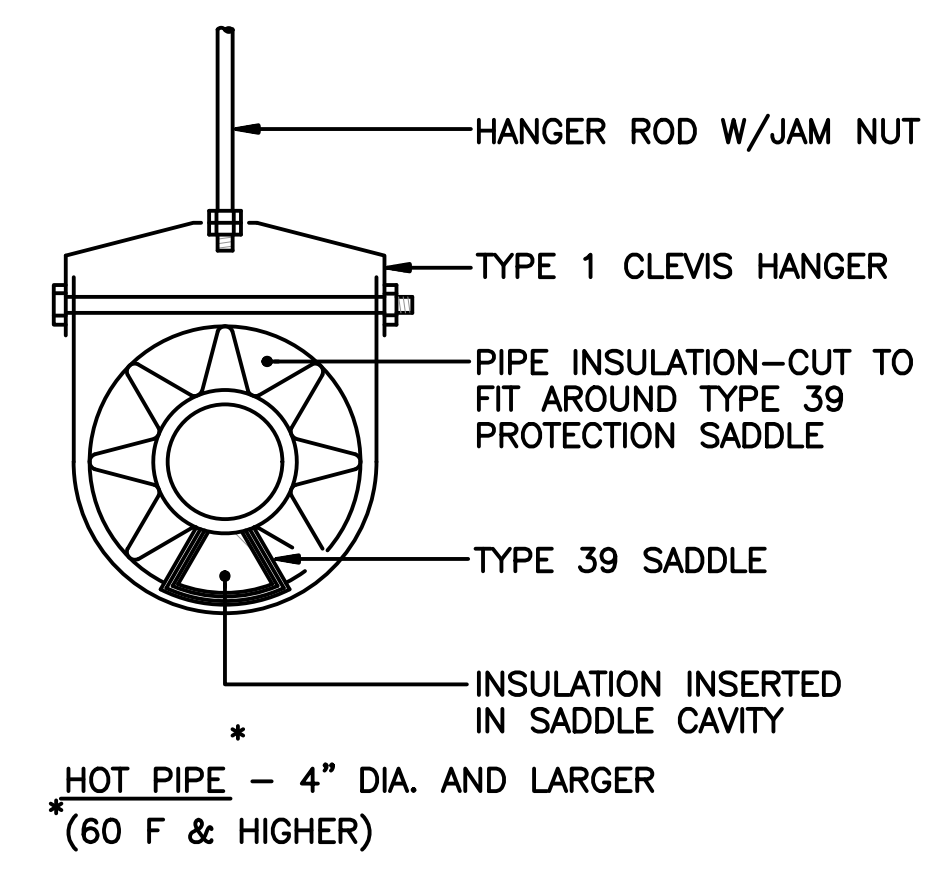

2 PIPE HANGAR DETAIL
NTS

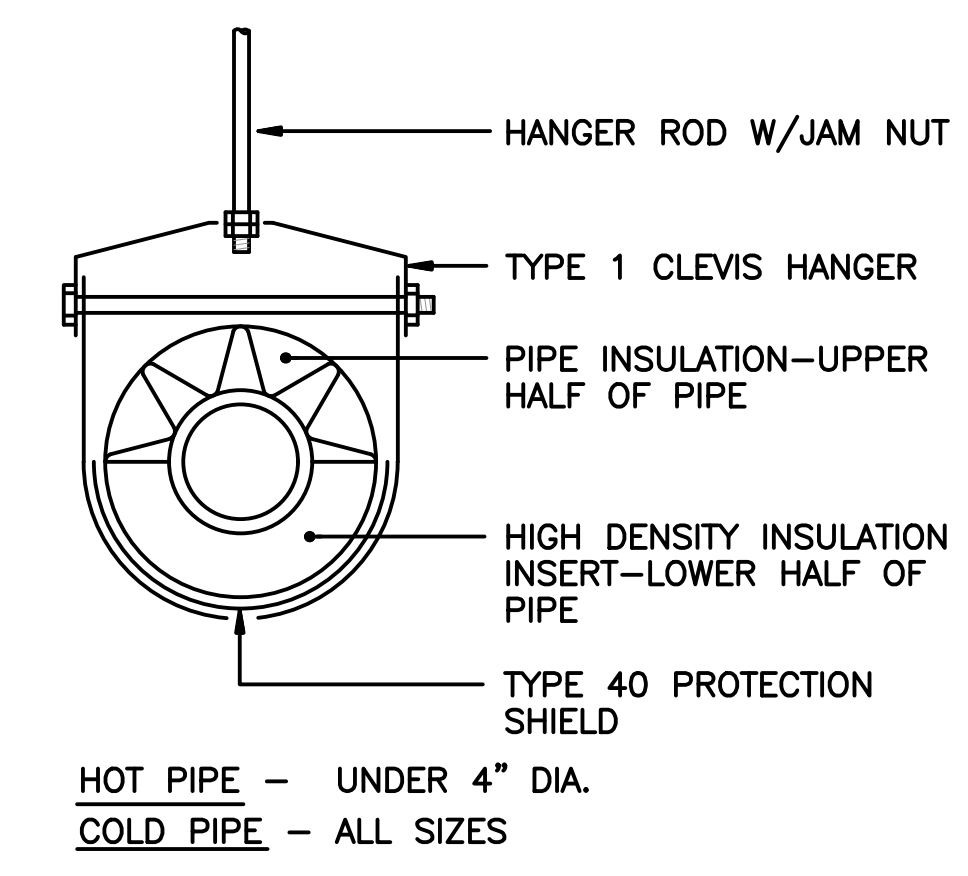

3 MOP SINK DETAIL
NTS

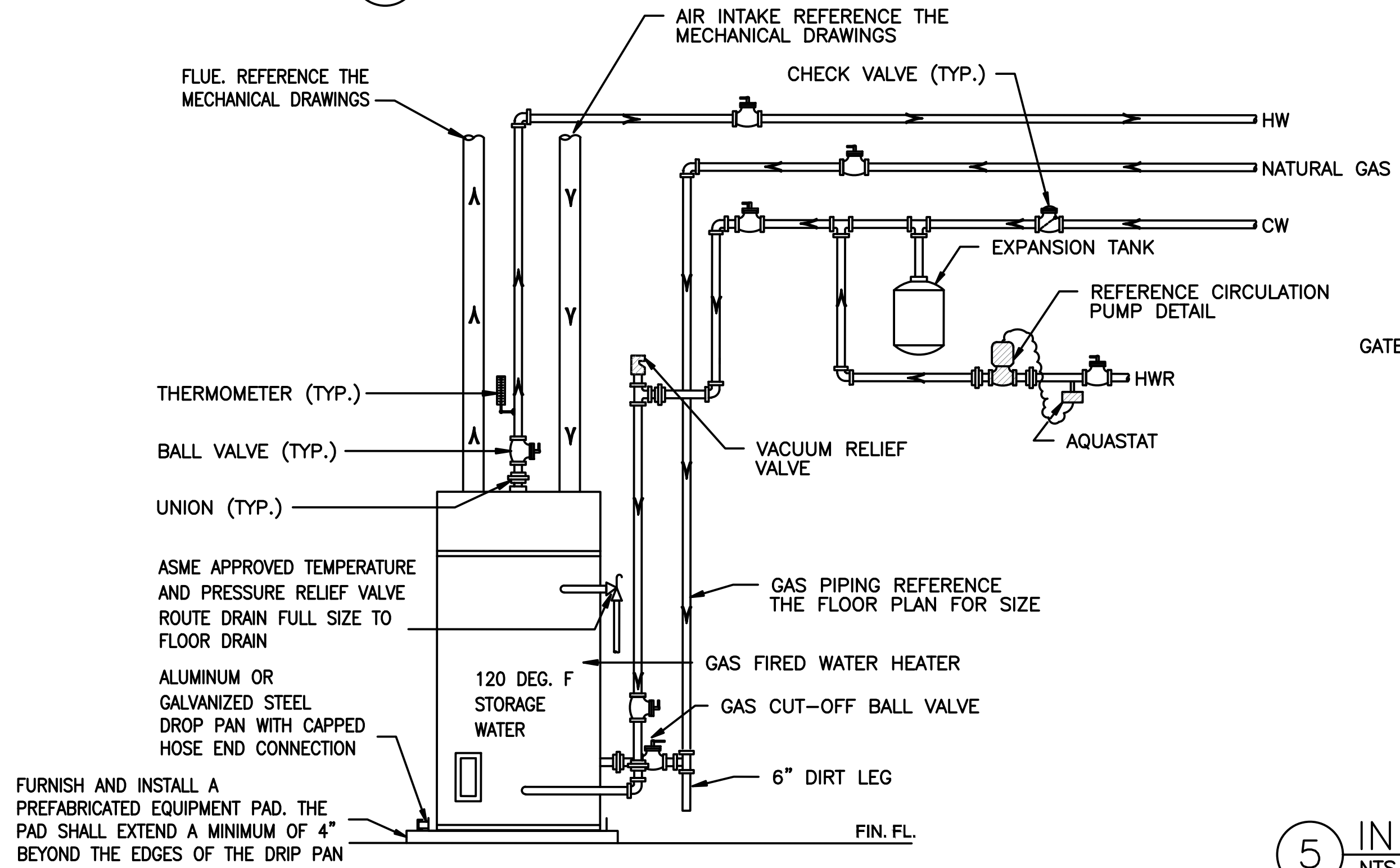
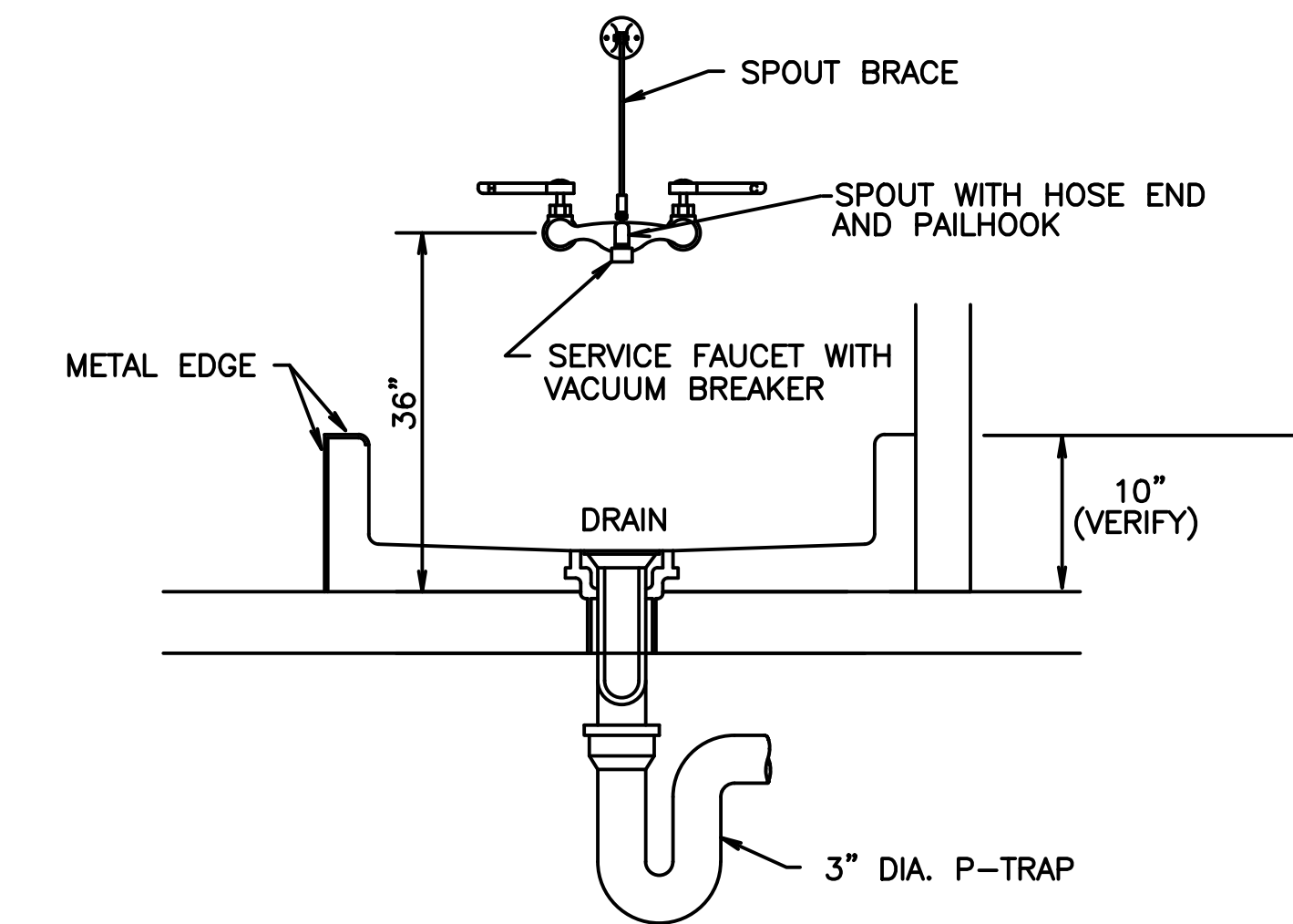

4 GAS FIRED WATER HEATER DTL
NTS

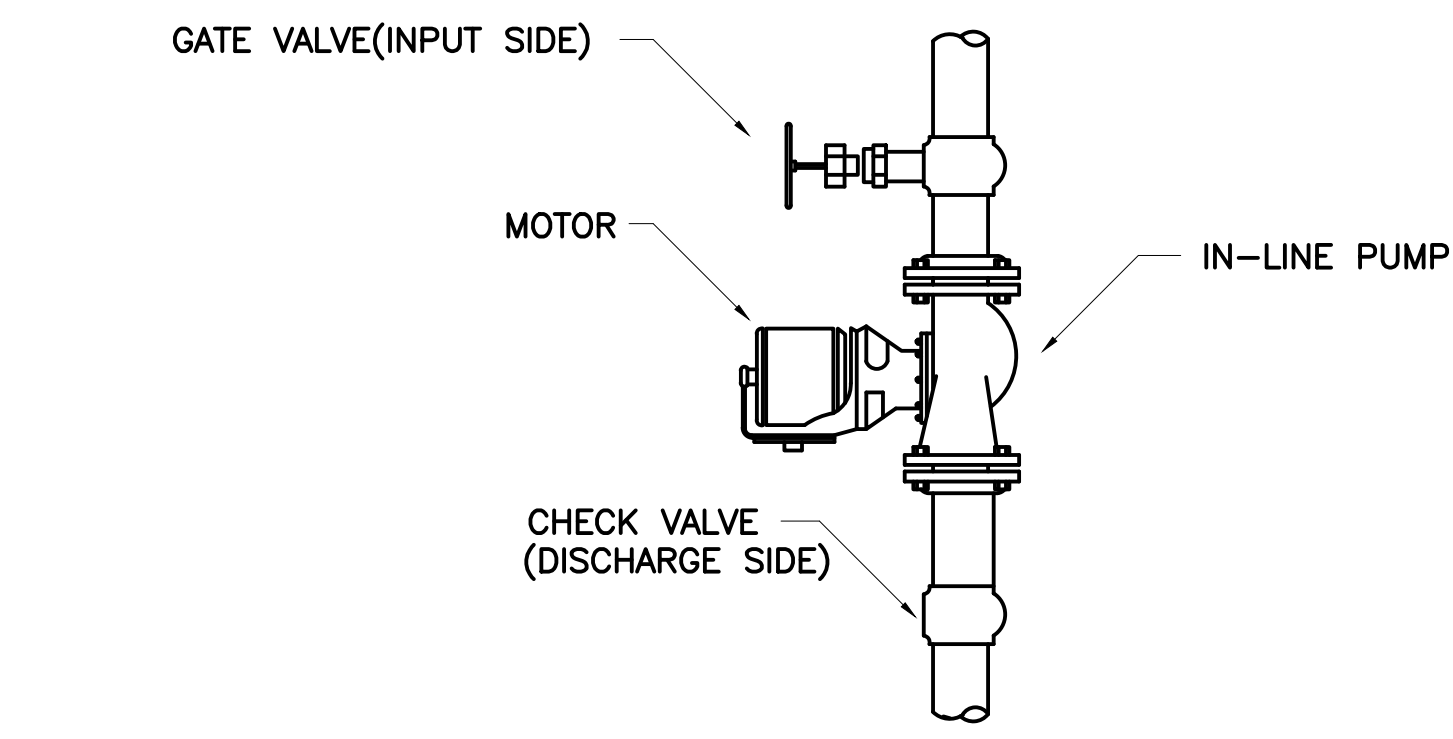

5 IN LINE RECIRCULATION PUMP DTL.
NTS

6 FLUE THROUGH ROOF DETAIL
NTS

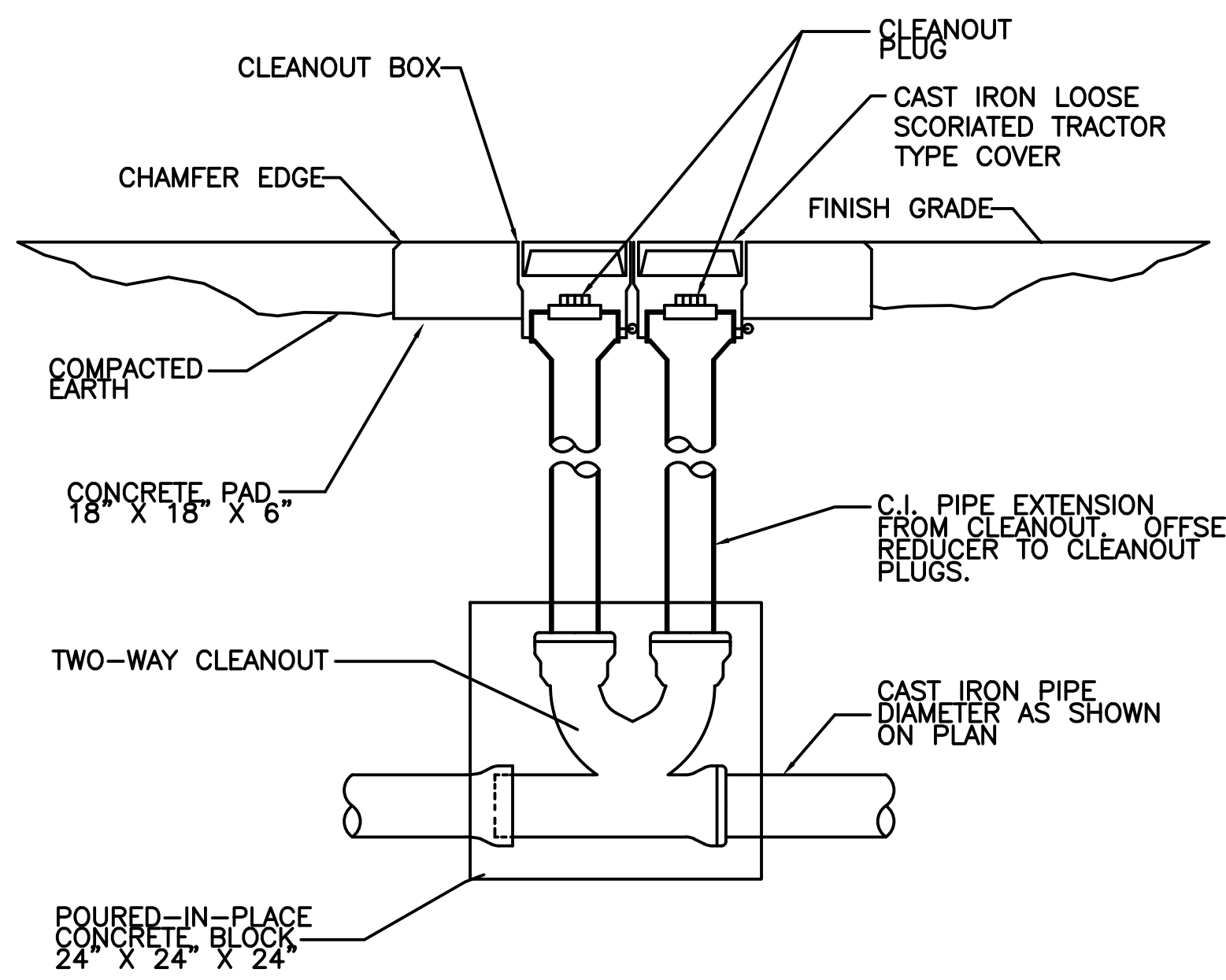

7 EXTERIOR AND DOUBLE CLEANOUT DETAIL
NTS

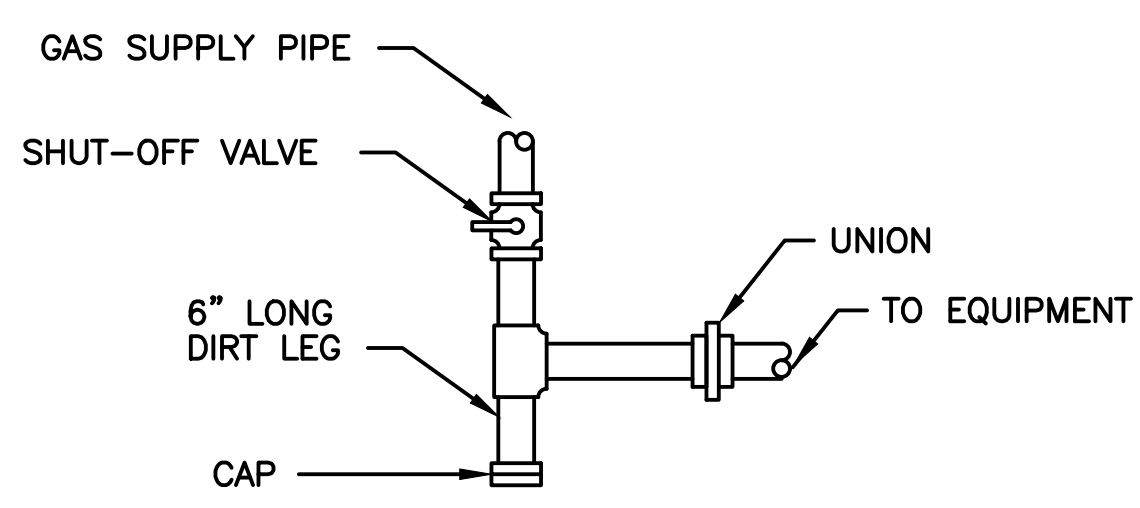

8 GAS CONNECTION DETAIL (TYP.)
NTS

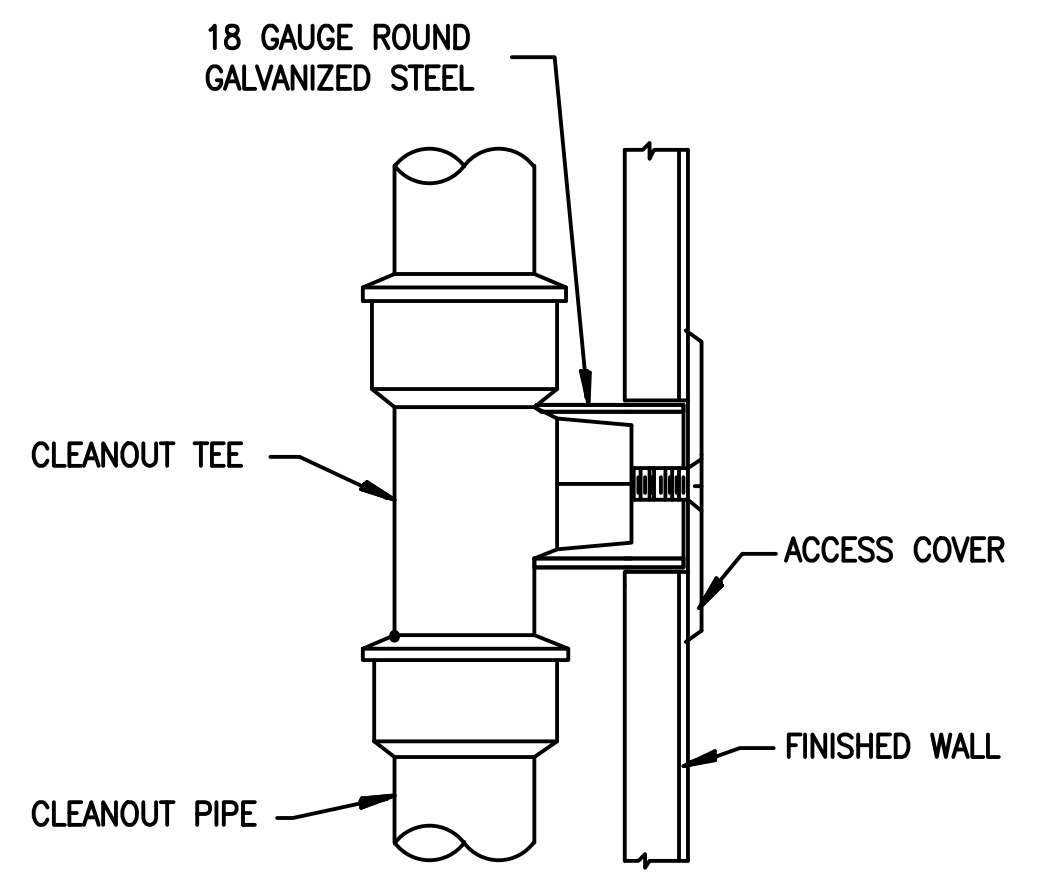

9 WALL CLEANOUT DETAIL
NTS

10 FIRE PROTECTION DETAIL
WALL/FLOOR PENETRATION
NTS

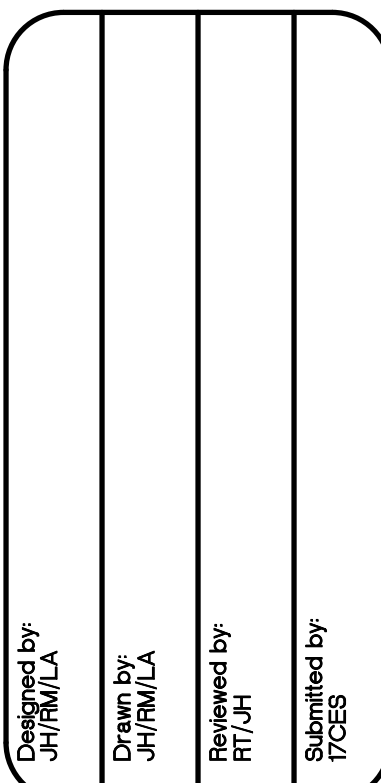
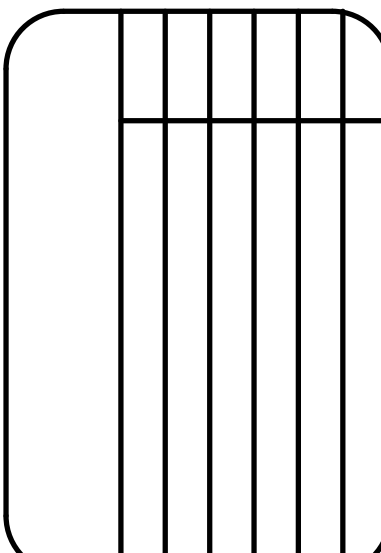
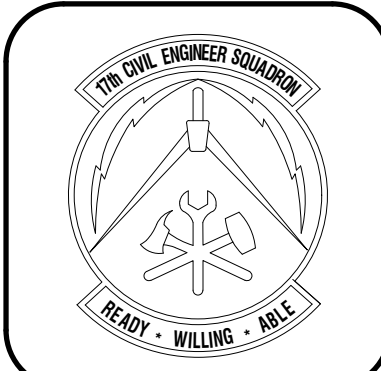

PROJECT TITLE
FIRE STATION ADD/ALTER, B3321
PROJECT NO. 1039839
17th TRAINING WING
GOODFELLOW AIR FORCE BASE, TEXAS

Project Number:
1039839
 SHEET TITLE
PLUMBING DETAILS 1
 Date:
 SEP 2023

SEQ. SHEET OF
 50 **P-501** 50

PLUMBING FIXTURE SCHEDULE									
MARK	DESCRIPTION	WASTE PIPE	VENT PIPE	COLD WATER	HOT WATER	WASTE FIXTURE UNITS	ELECTRICAL	REMARKS	BASIS OF DESIGN MANUFACTURER & MODEL NUMBER
		IN	IN	IN	IN				
WC-1	WATER CLOSET, 1.1/1.6 G.P.F. FLUSHOMETER, SIPHON JET WITH ENLONGATED BOWL AND TOP SULLY SPUD, MOUNT RIM AT 16-1/2" A.F.F. FOR ADA/ABA COMPLIANCE, VERIFY FLUSH HANDLE PER TDLR REQUIREMENTS. FLOOR FLANGE SHALL BE COPPER ALLOY, CAST IRON, OR PLASTIC. GASKET SHALL BE WAX-TYPE SEAL. COLOR: WHITE FLUSHVALVE: DUAL FLUSH MANUAL	4	2	1	-	4	N/A	VITREOUS CHINA, TOP SPUD, FLOOR MOUNTED, FLOOR OUTLET, ELONGATED BOW, PROVIDE WITH HEAVY DUTY INJECTION MOLDED PLASTIC, OPEN FRONT TOILET SEAT WITH COVER AND CHECK HINGES COMPLYING WITH ANSI Z124.5 FOR COMMERCIAL HEAVY DUTY. FIXTURE SHALL BE FURNISHED AND INSTALLED IN ACCORDANCE WITH ADA/ABA STANDARDS FOR ADULTS.	WATER CLOSET: KOHLER Highdill Ultra #K-96057 FLUSH VALVE: SLOAN WES 111-1.6/1.1 SEAT: BEMIS COMMERCIAL #1955SSCT
WC-2	WATER CLOSET, 1.1/1.6 G.P.F. FLUSHOMETER, SIPHON JET WITH ENLONGATED BOWL AND TOP SUPPLY SPUD, MOUNT RIM AT 15" A.F.F., VERIFY FLUSH HANDLE PER TDLR REQUIREMENTS. COLOR: WHITE FLUSHVALVE: DUAL FLUSH MANUAL	4	2	1	-	4	N/A	VITREOUS CHINA, TOP SPUD, FLOOR MOUNTED, FLOOR OUTLET, ELONGATED BOW, PROVIDE WITH HEAVY DUTY INJECTION MOLDED PLASTIC, OPEN FRONT TOILET SEAT WITH COVER AND CKECK HINGES COMPLYING WITH ANSI Z124.5 FOR COMMERCIAL HEAVY DUTY. FIXTURE SHALL BE FURNISHED AND INSTALLED IN ACCORDANCE WITH ADA/ABA STANDARDS FOR ADULTS.	WATER CLOSET: KOHLER Highdill Ultra #K-96057 FLUSH VALVE: SLOAN WES 111-1.6/1.1 SEAT: BEMIS COMMERCIAL #1955SSCT
UR-1	URINAL, 0.125 GPF FLUSHOMETER ULTRA HIGH EFFICIENCY WASHOUT, MOUNT RIM AT 17" A.F.F FOR ADA/ABA COMPLIANCE. COLOR: WHITE	2	2	3/4	-	2	N/A	VITREOUS CHINA, TOP SPUD, WALL CARRIER SYSTEM, BACK OUTLET, EXTENDED RIM, WASHOUT FLUSHING ACTION, CHROME-PLATED MANUAL FLUSHOMETER. FIXTURE SHALL BE FURNISHED AND INSTALLED IN ACCORDANCE WITH ADA/ABA STANDARDS FOR ADULTS.	URINAL: KOHLER BARDON #K-4991-ET-0 FLUSH VALVE: SLAON REGAL #186-0.125
UR-2	URINAL, 0.125 GPF FLUSHOMETER ULTRA HIGH EFFICIENCY WASHOUT, MOUNT RIM AT 24" A.F.F. COLOR: WHITE	2	2	3/4	-	2	N/A	VITREOUS CHINA, TOP SPUD, WALL CARRIER SYSTEM, BACK OUTLET, EXTENDED RIM, WASHOUT FLUSHING ACTION, CHROME-PLATED MANUAL FLUSHOMETER, PROVIDE WITH CONCEALED FLOOR MOUNTED HANGAR, PROVIDE WITH CONCEALED FLOOR MOUNTED HANGAR.	URINAL: KOHLER BARDON #K-4991-ET-0 FLUSH VALVE: SLAON REGAL #186-0.125
LV-1	LAVATORY, ACCESSIBLE, ADA COMPLIANT, UNDER COUNTER MOUNTED ENAMELED CAST IRON, COUNTED MOUNTED, SINGLE LEVER 4" ON CENTER CHROME-PLATED FAUCET, LESS POP-UP, 0.5 GPM AERATOR, GRID STRAINER DRAIN AND THERMOSTATIC MIXING VALVE. PIPE INSULATION: WHITE FOAM PER ADA COLOR: WHITE	2	2	1/2	1/2	1	N/A	FLUSHOMETER. FIXTURE SHALL BE FURNISHED AND INSTALLED IN ACCORDANCE WITH ADA/ABA STANDARDS FOR ADULTS. FURNISH AND INSTALL TMV-1 AND PIPING PROTECTION COVERS BELOW THE LAVATORY.	LAVATORY: KOHLER #K-2874 FAUCET: AMERICAN STANDARD #7385050.002
SHR-1	SHOWER ASSEMBLY WITH TEMP/TROL PRESSURE BALANCED MIXING VALVE WITH INTEGRAL SERVICE STOPS, 1.5 GPM, VOLUME DIVERTER, INTEGRAL VOLUME CONTROL, VACUUM BREAKER, TRIM AND DRAIN.	2	2	1/2	1/2	2	N/A	THE HOT WATER LIMIT STOPS SHALL BE SET TO 110 DEGREES FARENHEIT. MIXING VALVE SHALL BE ASSE 1016 COMPLIANT.	SHOWER ASSEMBLY:
MS-1	HIGH DENSITY COMPOSITE SERVICE BASIN WITH INTEGRAL DRAIN, STAINLESS STEEL STRAINER, HOSE & BRACKET, MOP HANGAR AND WALL-MOUNTED CHROME PLATED FAUCET WITH VACUUM BREAKER, INTEGRAL STOPS, ADJUSTABLE WALL BRACE, PAIL HOOK AND 3/4" THREAD ON SPOUT, STAINLESS STEEL WALL GUARDS.	3	2	1/2	1/2	2	N/A	THE FIXTURE SHALL BE FURNISHED AND INSTALLED WITH 120 DEGREE FARENHEIT PIPING.	MOP BASIN: #Z1996-24 FAUCET: DELTA #28T9 HOSE & BRACKET: ZURN #Z1996-HH MOP HANGER: ZURN #Z1996-MH WALL GUARD: ZURN #Z1996-WG
EW-1.2	WATER COOLER, WALL MOUNTED, BI-LEVEL, UL LISTED, BARRIER FREE PER ANSI A117.1-1980. MEETS ADA AND TDLR ACCESSIBILITY REQUIREMENTS.	2	2	3/4	3/4	.5	120 V, DUPLEX RECEPTACLE	FIXTURE SHALL BE FURNISHED AND INSTALLED IN ACCORDANCE WITH ADA/ABA STANDARDS FOR ADULTS.	ELKAY #EZSTL8WSLK
TMV-1	PIPE PER MANUFACTURE RECOMMENDED PIPING INSTRUCTIONS. POINT OF USE ASSE 1070 COMPLIANT THERMOSTATIC MIXING VALVE.	-	-	1/2	1/2	-	N/A	-	WATTS #LFMMV
FD-1	FLOOR DRAIN, CAST IRON WITH ANCHOR FLANGE AND 6" SQUARE NICKEL BRONZE STARINER WITH VANDAL RESISTANT SCREWS.	3	2	-	-	2	N/A	FURNISH AND INSTALL WITH TRAP GUARD INSERT.	MIFAB #F1100 SERIES
RCP-1	DOMESTIC HOT WATER RECIRCULATION PUMP, BRONZE CONSTRUCTION, DOMESTIC WATER CIRCULATOR PUMP, WITH AQUASTAT AND PROGRAMMABLE TIMER.	-	-	-	-	-	120 V, DUPLEX RECEPTACLE	FURNISH AND INSTALL WITH PROGRAMMABLE TIMER AND AQUASTAT.	BELL & GOSSETT #ECCOCIRC 19-16 SERIES

WATER HEATER SCHEDULE							
MARK	STORAGE (GALLONS)	RECOVERY CAPACITY @90° F RISE, BASED ON 96% THERMAL EFFICICNTY (GAL/HR)	ELECTRICAL		BASIS OF DESIGN	TYPE	NOTES
			VOLTS	PHASE			
WH-1	119	388	120	1	AO SMITH BTH-300(A)	GAS-FIRED	1,2,3

NOTES:
1. REFERENCE DETAIL 3/P-501 FOR ADDITIONAL INSTALLATION REQUIREMENTS.
2. THE WATER HEATER SHALL BE INSTALLED IN ACCORDANCE WITH CODE/AHJ REQUIRED DRAIN PAN, T&P VALVE, EXPANSION TANK, HEAT TRAP, STAND, SHUT-OFF VALVES, CHECK VALVE AND APPURTENANCES
3. SET THE INTEGRAL WATER HEATER CONTROLS TO MAINTAINING THE STORAGEE WATER AT 120° F.

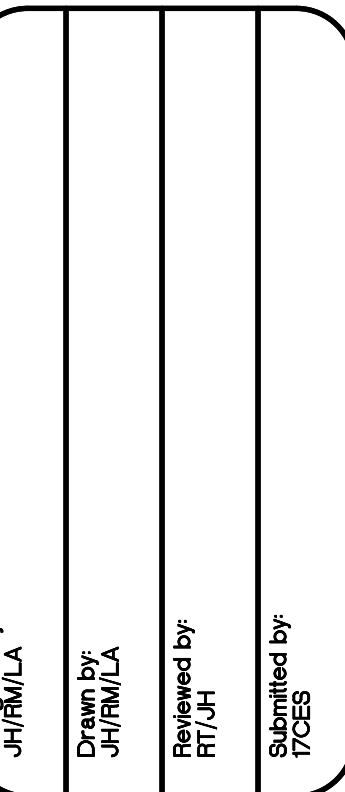
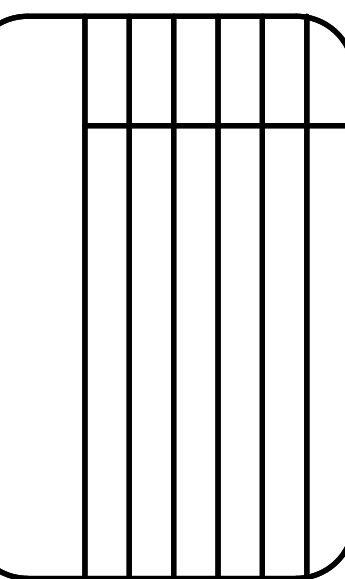
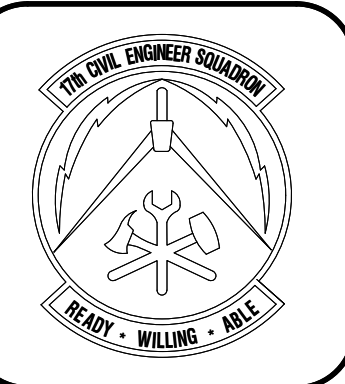

PROJECT TITLE
FIRE STATION ADD/ALTER, B3321
PROJECT NO. 1039839
17th TRAINING WING
GOODFELLOW AIR FORCE BASE, TEXAS

Project Number:
1039839
SHEET TITLE
PLUMBING SCHEDULES
Date:
SEP 2023

SEQ. **SHEET** **OF**
52 **P-601** 50

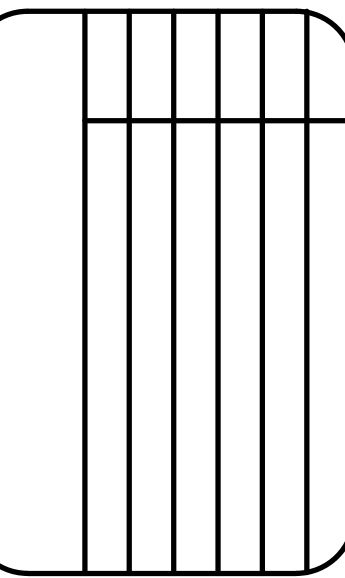
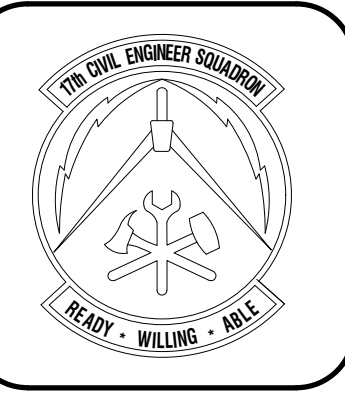

Designed by: JH/ML/A
 Drawn by: JH/ML/A
 Reviewed by: RT/JH
 Submitted by: PC/ES

PROJECT TITLE
FIRE STATION ADD/ALTER, B3321
PROJECT NO. 1039839
17th TRAINING WING
GOODFELLOW AIR FORCE BASE, TEXAS

Project Number:
1039839
 SHEET TITLE
FIRE PROTECTION PLAN
 NOTES & SYMBOLS
 Date:
SEP 2023

SEQ. SHEET OF
 54 **FA-001** 50

GENERAL NOTES:

1. THE CONTRACTOR SHALL PROVIDE THE SERVICES OF A QUALIFIED FIRE PROTECTION ENGINEER (QFPE) AS PART OF THEIR BID PROPOSAL TO COMPLETE THE REQUIRED ITEMS AS DESCRIBED IN THESE DRAWINGS.
2. THE INFORMATION PROVIDED ON THE CONTRACT DOCUMENTS SERVES TO GUIDE THE CONTRACTOR IN THE DESIGN AND INSTALLATION OF A COMPLETE FIRE PROTECTION SYSTEM.
3. MUST COMPLY WITH UFC 1-200-01. NOTE: THIS UFC REFERENCES ALL OTHER DOD UFCs AND BUILDING CODES. MUST COMPLY WITH UFC 3-600-01 AND ALL STANDARDS AND CODES REFERENCED BY THIS UFC. THIS INCLUDES, BUT IS NOT LIMITED TO, NFPA STANDARDS AND CODES, ICC CODES, TIA STANDARDS, CEREG DESIGN GUIDE.
4. ALL DESIGN WORK SHALL BE PERFORMED BY A QUALIFIED FIRE PROTECTION ENGINEER (QFPE). THIS FPE SHALL ALSO BE CONSIDERED THE QUALIFIED FIRE PROTECTION ENGINEER (QFPE) FOR THIS PROJECT AS DEFINED BY UFC 3-600-01, AND SHALL BE RESPONSIBLE FOR PERFORMING ALL WORK DESCRIBED IN THAT UFC FOR QFPE.
5. THE QFPE SHALL BE REGULARLY AND DIRECTLY INVOLVED IN ALL ASPECTS OF DESIGN, INSTALLATION, ACCEPTANCE TESTING AND COMMISSIONING OF FIRE PROTECTION, FIRE ALARM AND LIFE SAFETY SYSTEMS AND FEATURES. THE QFPE SHALL PERSONALLY CONDUCT AND/OR WITNESS ALL ACCEPTANCE TESTING FOR FIRE PROTECTION, FIRE ALARM AND LIFE SAFETY SYSTEMS AND FEATURES.
6. THE QFPE SHALL BE RESPONSIBLE FOR REVIEWING DESIGNS AND SUBMITTALS FOR ALL TRADES TO ENSURE THAT FIRE PROTECTION AND LIFE SAFETY FEATURES ARE MAINTAINED THROUGHOUT THE CONTRACT. THIS INCLUDES, BUT IS NOT LIMITED TO, DEVELOPING AND SUBMITTING THE REVIEW LETTER AT THE 100% DESIGN DESCRIBED IN UFC 3-600-01 SECTION 1-7.3.
7. ADDITIONAL INFORMATION REGARDING FIRE PROTECTION AND LIFE SAFETY REQUIREMENTS CAN BE FOUND IN THE ARCHITECTURAL AND ELECTRICAL SECTIONS. THE QFPE AS DESCRIBED ABOVE SHALL BE RESPONSIBLE FOR OVERSEEING THE DESIGN, INSTALLATION, ACCEPTANCE TESTING AND COMMISSIONING OF ALL FIRE PROTECTION AND LIFE SAFETY REQUIREMENTS FOUND THROUGHOUT THIS CONTRACT.
8. THE CONTRACTOR SHALL PROVIDE AN AS BUILT DRAWING AT THE END OF PROJECT.

DESIGN NOTES:

1. THE QFPE SHALL COORDINATE WITH ALL TRADES TO ENSURE THAT ALL MEANS OF EGRESS AND LIFE SAFETY COMPONENTS AND SYSTEMS AS DESCRIBED IN UFC 3-600-01 AND NFPA 101 ARE DESIGNED, INSTALLED AND TESTED IN ACCORDANCE WITH THE STANDARDS OF THIS SECTION.
2. THE NEW BUILDING THAT MEETS THE MINIMUM REQUIREMENTS FOR FIRE SPRINKLERS SHALL BE FULLY SPRINKLERED IN ACCORDANCE WITH UFC 3-600-01. THE MINIMUM PRESSURE AND FLOW REQUIREMENTS SHALL BE CALCULATED TO THE BASE OF RISER AND TO THE DEMARCATION BOUNDARY WITH POTABLE WATER AT THE BASE. THE BORE DATA SHALL BE ON THE NAMEPLATE FOR EACH SPRINKLER RISER. THE PRESSURE AND FLOW REQUIREMENTS AT THE POINT OF DEMARCATION SHALL BE PROVIDED IN WRITING TO THE GOVERNMENT NO LATER THAN THE 65% DESIGN STAGE. THE QFPE SHALL BE RESPONSIBLE FOR DETERMINING IF THE NEW BUILDING MEETS THE MINIMUM REQUIREMENTS FOR FIRE SPRINKLERS PER UFC 3-600-01 AND INCLUDE THIS IN THE DESIGN ANALYSIS. ALL BUILDINGS, BOTH NEW AND EXISTING, THAT MEET THE THRESHOLD FOR REQUIRING SPRINKLERS SHALL BE PROVIDED WITH AUTOMATIC FIRE SPRINKLERS IN ACCORDANCE WITH UFC 3-600-01 AND NFPA 13.
3. NEW BUILDING SHALL HAVE CALCULATED FIRE FLOWS FOR FIREFIGHTING PURPOSES PERFORMED BY THE QFPE IN ACCORDANCE WITH UFC 3-600-01 AND NFPA 1. THESE FIRE FLOWS SHALL BE PROVIDED TO THE GOVERNMENT IN WRITING PRIOR TO THE 65% DESIGN SUBMITTAL.
4. THE QFPE IS RESPONSIBLE FOR ALL FIRE PROTECTION DESIGN FROM THE POINT OF DEMARCATION DOWN THROUGHOUT BUILDING. THE CONTRACTOR SHALL BE RESPONSIBLE FOR PROVIDING ALL EQUIPMENT, MATERIALS AND CONSTRUCTION REQUIRED TO DELIVER A FULLY OPERATIONAL FIRE SPRINKLER AND FIRE ALARM SYSTEMS TO THE GOVERNMENT, FOR THE NEW BUILDING REQUIRING FIRE SPRINKLERS AND FIRE ALARM BY THE QFPE PER THIS SCOPE OF WORK.
5. IF BID OPTIONS ARE AWARDED. CONTRACTOR SHALL INCLUDE ALL NECESSARY SHOP DRAWINGS, CALCULATIONS, DIAGRAMS, DEVICES, MATERIALS, LABOR, SUPERVISION, AND ACCESSORIES NEEDED FOR COMPLETE AND FUNCTIONAL SYSTEM IN EACH BID OPTION AWARDED. IN EACH OPTION AWARDED THE CONTRACTOR SHALL BE RESPONSIBLE FOR REMOVING AND DEMOLISHING EXISTING FIRE ALARM DEVICES, CORRESPONDING CONDUIT, JUNCTION BOXES, WIRING, AND ACCESSORIES AND PROVIDE NEW.

FIRE ALARM SYSTEM:

1. THE FIRE CONTROL UNIT SHALL COMPLY WITH UFC 3-600-01 AND NFPA 72. THE ADDRESSABLE FIRE ALARM CONTROL PANEL SHALL BE MONACO MAAP-X, MODEL 227-965-XX (WITH INTERNAL RADIO). THE SYSTEM SHALL INCLUDE AN OMNI DIRECTIONAL ANTENNA AND LIGHTNING ARRESTOR.
2. THE FIRE ALARM SYSTEM SHALL PROVIDE THE FOLLOWING:
 - A. TRANSMISSION OF ALARM, SUPERVISORY, AND TROUBLE SIGNALS TO THE GOODFELLOW AIR FORCE BASE FIRE DEPARTMENT (GFABFD).
 - B. CARBON MONOXIDE DETECTION IN ROOMS WITH AND ADJACENT TO FUEL BURNING EQUIPMENT INCLUDING DISTINCT NOTIFICATION FOR CARBON MONOXIDE ALARMS IN ACCORDANCE TO UFC 3-600-01
 - C. DEACTIVATION OF HEATING VENTILATION AND AIR CONDITIONING FANS UPON FIRE ALARM ACTIVATION
3. CONTRACTOR SHALL ENSURE THAT 17 CES FIRE ALARM TECHNICIANS, 17 CES FIRE PREVENTION OFFICE, PROJECT MANAGER AND OTHER STAKEHOLDERS IN ACCORDANCE WITH NFPA AND UFC-03-600-1; ARE NOTIFIED OF ALL ALARM SYSTEM AND SPRINKLER SYSTEM ACCEPTANCE TEST.
4. CONTRACTOR SHALL PROVIDE ALL CERTIFICATION DOCUMENTATION TO THE 17 CES FIRE PREVENTION OFFICE WHEN THE ALARM ACCEPTANCE TESTING IS COMPLETE.

KEYNOTES:

1. DESIRED LOCATION OF FIRE PROTECTION SYSTEM RISER. DESIGN TO BE MINIMUM DISTANCE FROM SURROUNDING WALLS TO ENSURE THAT IT DOES NOT OBSTRUCT THE EXHAUST FAN IN THE MECHANICAL ROOM.
2. LOCATION OF NEW FIRE ALARM CONTROL PANEL (FACP)

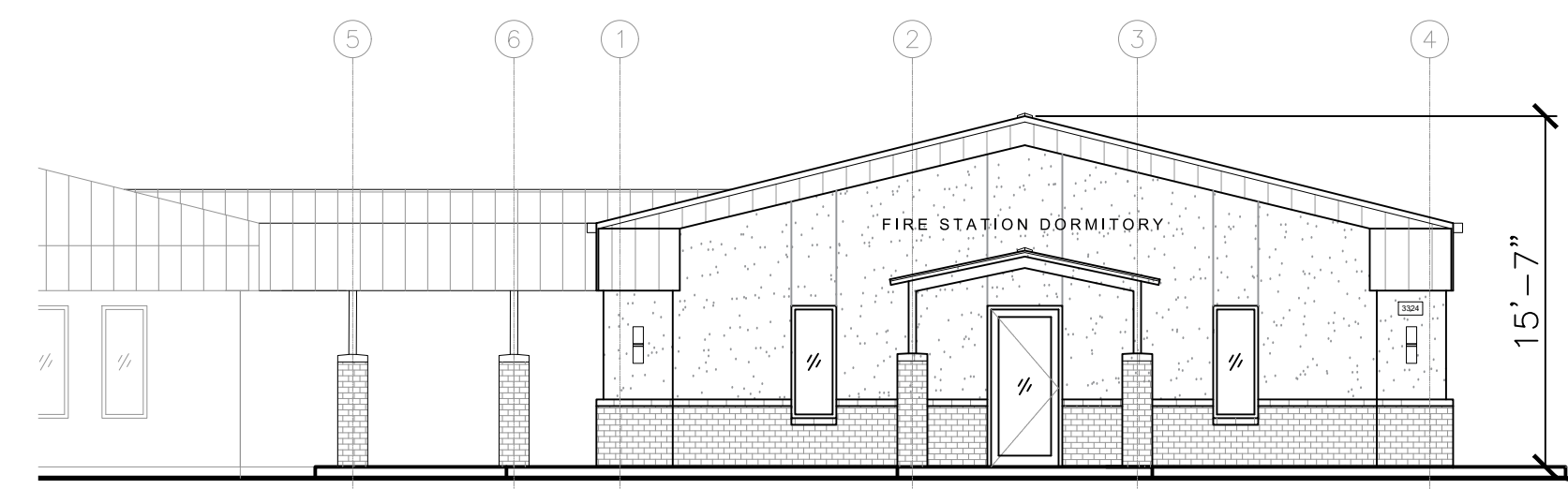
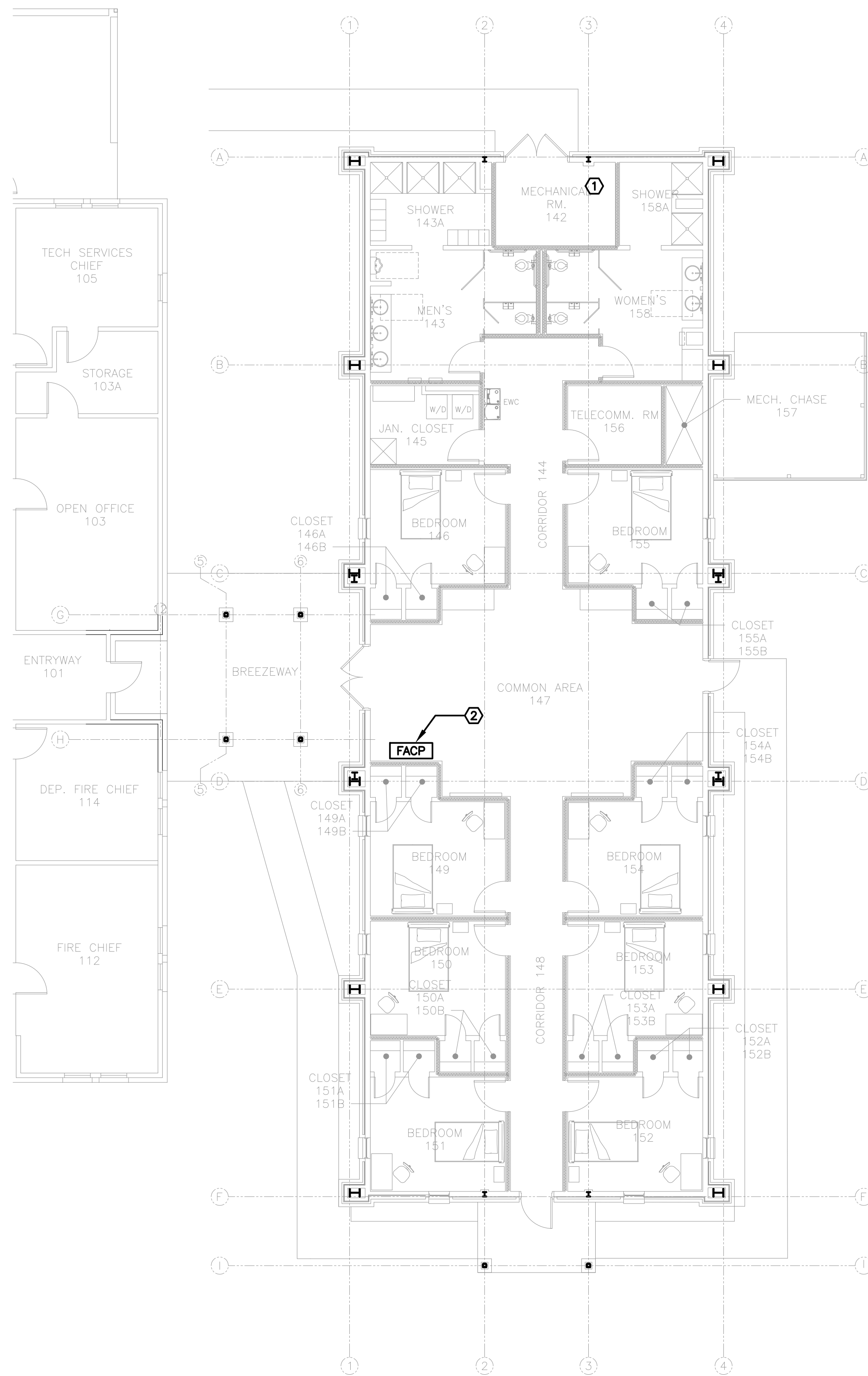

② SOUTH ELEVATION
 $\frac{1}{8}'' = 1' - 0''$

① NEW ADDITION FLOORPLAN
 $\frac{1}{8}'' = 1' - 0''$