

“Technical Specifications” for East Andrews Drainage Improvements – Phase 1

March 2023

OWNER:

Georgetown County
129 Screven St
Georgetown, SC 29442

PREPARED BY:

Davis & Floyd, Inc.
1940 Algonquin Rd, Suite 301
Charleston, SC 29405
(843) 554-8602

D|F

D|F Job No.: 31969.00

Bid No.: 21-038

EDA Investment ID: 04-79-07486

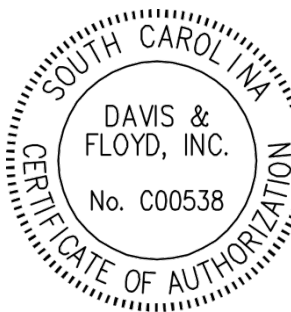

03/03/2023

TABLE OF CONTENTS

Page Number

SPECIAL PROVISIONS	1
(1) REFERENCES:	1
(2) STANDARDS AND REFERENCES:.....	1
(3) ERRATA TO 2007 STANDARD SPECIFICATIONS FOR HIGHWAY CONSTRUCTION:	1
(4) PROPOSAL ITEMS AND QUANTITIES:	1
(5) SUBMITTALS:	2
(6) MANUFACTURERS MATERIALS CERTIFICATIONS AND CERTIFIED TEST REPORTS:	2
(7) AS-BUILT CONSTRUCTION PLANS:.....	2
(8) SECTION 101: SUBSTANTIAL COMPLETION OF WORK.....	3
(9) DIVISION 100: STANDARD DRAWINGS:.....	3
(10) DIVISION 100: IMMINENT STANDARD DRAWINGS:	3
(11) DIVISION 100: STANDARD DRAWING ERRATA:.....	3
(12) SECTION 103.8: CONTRACTOR'S LIABILITY INSURANCE:	6
(13) SECTION 105: CONSTRUCTION STAKES, LINES, AND GRADES:	6
(14) SECTION 106: QUALIFIED PRODUCT LISTINGS	6
(15) CONSTRUCTION SCHEDULE	6
(16) SECTION 106: SOUTH CAROLINA MINING ACT:	6
(17) SECTION 107: PROJECT BULLETIN BOARDS:.....	7
(18) SECTION 107: FAIR LABOR STANDARDS ACT OF 1938, AS AMENDED:.....	7
(19) SECTION 107: APPLICATION OF DAVIS-BACON AND RELATED ACTS TO INDEPENDENT TRUCK DRIVERS AND MISCELLANEOUS CONSTRUCTION ACTIVITIES:.....	7
(20) SECTION 107: REQUIREMENTS FOR FEDERAL AID CONTRACTS WHICH AFFECT SUBCONTRACTORS, DBE HAULERS, MATERIAL SUPPLIERS AND VENDORS:	7
(21) SECTION 107: CARGO PREFERENCE ACT REQUIREMENTS:	7
(22) SECTION 107: IRAN DIVESTMENT ACT:.....	8
(23) SECTION 107: LATE DISCOVERY OF ARCHAEOLOGICAL/HISTORICAL REMAINS ON FEDERAL AID PROJECTS AND APPROVAL OF DESIGNATED BORROW PITS:.....	8
(24) SECTION 107: CRANE SAFETY:.....	9
(25) SECTION 107: REQUIRED MEDIA NOTIFICATION FOR CONSTRUCTION PROJECTS:	9
(26) SECTION 107: CONTRACT PROVISION TO REQUIRE CERTIFICATION AND COMPLIANCE CONCERNING ILLEGAL ALIENS.....	9
(27) SECTION 208: FINE GRADING:	9
(28) SECTION 305: MAINTENANCE STONE:.....	9
(29) DIVISION 600: MANUAL ON UNIFORM TRAFFIC CONTROL DEVICES:	9
(30) DIVISION 600: TRAFFIC CONTROL:.....	9
(31) SECTION 602: GENERAL REQUIREMENTS FOR PROVIDING AND MAINTAINING TRAFFIC CONTROL DEVICES IN THE WORK ZONE:	9
(32) SECTION 602: PERMANENT CONSTRUCTION SIGNS:.....	9
(33) SECTION 610: WORK ZONE TRAFFIC CONTROL PROCEDURES:	10
(34) SECTION 815: EROSION CONTROL MEASURES:	10
(35) EXCAVATED MATERIALS.....	10
(36) PROMPT PAYMENT CLAUSE:.....	10
(37) EDA REQUIRED SPECIFICATION DOCUMENTS.....	10

SUPPLEMENTAL SPECIFICATIONS

ERRATA TO 2007 STANDARD SPECIFICATIONS FOR HIGHWAY CONSTRUCTION
THE SOUTH CAROLINA MINING ACT
AS-BUILT CONSTRUCTION PLANS
CRANE SAFETY
APPLICATION OF DAVIS-BACON AND RELATED ACTS TO INDEPENDENT TRUCK DRIVERS AND
MISCELLANEOUS CONSTRUCTION ACTIVITIES
REQUIREMENTS FOR FEDERAL AID CONTRACTS WHICH AFFECT SUBCONTRACTORS, DBE
HAULERS, MATERIAL SUPPLIERS AND VENDORS
LATE DISCOVERY OF ARCHAEOLOGICAL/HISTORICAL REMAINS ON FEDERAL AID PROJECTS
AND APPROVAL OF DESIGNATED BORROW PITS
VERTICAL DRAINS
FINE GRADING
TRAFFIC CONTROL
SECTION 810: EROSION CONTROL MEASURES
PROMPT PAYMENT CLAUSE

APPENDIX A

DAVIS-BACON WAGE RATES
LOBBYING CERTIFICATION AND RESTRICTION FORM (CD-512)
REQUIREMENTS FOR AFFIRMATIVE ACTION (EEO)
EDA CONTRACTING PROVISIONS FOR CONSTRUCTION PROJECTS
EDA CONSTRUCTION SITE SIGN SPECIFICATIONS

SPECIAL PROVISIONS

PROJECT ID

31969.00

PROPOSAL ID

Bid #21-038

COUNTY

Georgetown

EDA INVESTMENT ID

04-79-07486

This project is to be constructed under the South Carolina Department of Transportation's Specifications For Highway Construction Edition of 2007, the South Carolina Department of Transportation's 2004 Construction Manual, the Supplemental Technical Specifications in effect at the time of the letting, and the following Special Provisions.

(1) REFERENCES:

For purposes of this Contract references to the Department shall refer to the Georgetown County Department of Public Services. References to the "Resident Construction Engineer", "Director of Traffic Engineering" or "Engineer's Representative" shall refer to Georgetown County.

(2) STANDARDS AND REFERENCES:

This project is to be constructed under the SCDOT 2007 Standard Specifications for Highway Construction, the 2009 SCDOT Standard Drawings, the SCDOT 2004 Construction Manual, the SCDOT Supplemental Technical Specifications in effect at the time of the letting, and the following Special Provisions:

The above noted publications are available on the internet as follows, or may be obtained from the SCDOT Engineering Publications office at (803) 737-4533 or via e-mail at enrpubsales@dot.state.sc.us

SCDOT 2007 Standard Specifications for Highway Construction	http://www.scdot.org/doing/doingPDFs/2007_full_specbook.pdf
2009 SCDOT Standard Drawings	Standard Drawings Disclaimer
SCDOT 2004 Construction Manual	SCDOT Construction Manual (2004)
SCDOT Supplemental Technical Specifications	Supplemental Technical Specifications
South Carolina Manual on Uniform Traffic Control Devices (SCMUTCD)	http://www.scdot.org/doing/technicalPDFs/mutcdSupp/supplement_mutcd.pdf
Approved Products List for Traffic Control Devices in Work Zones	Traffic Engineering Manuals

(3) ERRATA TO 2007 STANDARD SPECIFICATIONS FOR HIGHWAY CONSTRUCTION:

See attached Supplemental Specification dated **January 1, 2018**.

(4) PROPOSAL ITEMS AND QUANTITIES:

A list of bid items and quantities is included in this project manual. The bidder shall submit his proposal on the form furnished. The bidder shall state the prices, in figures, for which he proposes

SPECIAL PROVISIONS

to do each item of work. All figures shall be written in ink. If an entry is made in the proposal and subsequently changed by the bidder, the original figure or figures shall be completely obliterated to eliminate any doubt as to the bid prices. All changes in the bid process shall be initiated by the bidder. The bidder shall show the products of the respective unit prices and quantities written in figures in the column provided for that purpose and the total amount of the proposal obtained by adding the amounts of the several items.

The bidder's proposal shall be signed correctly with ink. If the proposal is made by an individual, his name and post office address must be shown; if made by a firm or partnership, the name and post office address of each member of the firm or partnership must be shown; if made by a corporation, the person signing the proposal must show the name of the State under the laws of which the corporation is chartered, the names, titles and business addresses of the president, vice president, secretary and treasurer.

If two or more Contractors bid as a joint venture, the appropriate information on each Contractor must be shown as referred to in the foregoing paragraph for single Contractors.

(5) SUBMITTALS:

All submittals, regardless of origin, shall be stamped with the approval of the Contractor and identified with the name and number of this Contract, Contractor's name, and references to applicable specification paragraphs and Contract Drawings. Each submittal shall indicate the intended use of the item in the work. When catalog pages are submitted, applicable items shall be clearly identified and inapplicable data crossed out. The current revision, issue number, and date shall be indicated on all drawings and other descriptive data.

The Contractor shall be solely responsible for the completeness of each submittal. Contractor's stamp of approval is a representation to the Owner and Engineer that the Contractor accepts sole responsibility for determining and verifying all quantities, dimension, field construction criteria, materials, catalog numbers, and similar data, and that the Contractor shall reviewed and coordinated each submittal with the requirements of the work and the Contract Documents.

Engineer's review of submittals covers only general conformity to the Drawings and Specifications, external connections, and dimensions that affect layout; it does not indicate thorough review of all dimensions, quantities, and details of the material, equipment, device, or item covered. Engineer's review shall not relieve Contractor of sole responsibility for errors, omissions, or deviations in the drawings and data, nor of Contractor's sole responsibility for compliance with the Contract Documents.

Engineer's submittal review period shall be the consecutive number of calendar days as required (30) and shall commence on the first calendar day following receipt of the submittal in the Engineer's office. The time required to mail the submittal back to the Contractor shall not be considered a part of the submittal review period.

The contractor may be required to submit submittals through an online program at no additional cost to the contractor.

(6) MANUFACTURERS MATERIALS CERTIFICATIONS AND CERTIFIED TEST REPORTS:

The contractor shall supply the Resident Engineer with all required materials certifications and manufacturers test reports for items to be permanently incorporated into the project. These material certifications shall be provided prior to the materials use in the project. The Authority will supply the Resident Engineer with a list of required certifications and manufacturers tests based on the pay items and special provisions included in the proposals. The County Project Manager must approve these certifications and reports before payment can be made to the contractor for these items.

(7) AS-BUILT CONSTRUCTION PLANS:

See attached Supplemental Specification dated April 1, 2008.

SPECIAL PROVISIONS

The Contractor shall submit an electronic version of the as-builts in AutoCAD (.dwg) format.

(8) SECTION 101: SUBSTANTIAL COMPLETION OF WORK

Section 101.3.76 is hereby replaced with the following:

101.3.76 Substantial Completion of Work

Substantial Completion of Work is the point in the project when work has been constructed to the typical section in the Plans over the entire length of the project including tie-ins, all pay items have been installed in reasonable conformance with the plans and specifications over the entire length of the project and all lanes of traffic are open to the public in their final configuration with the final applications of thermoplastic and raised pavement markers with the only remaining work to be performed being punch list items.

(9) DIVISION 100: STANDARD DRAWINGS:

The Bidders are hereby advised that this project shall be constructed using the Current Standard Drawings with all updates effective at the time of the letting. The Standard Drawings are available for download at <https://www.scdot.org/business/standard-drawings.aspx>. All drawings that are updated are labeled with their effective letting date in red.

All references in the plans, standard specifications, supplemental specifications, supplemental technical specifications or special provisions to drawings under the previous numbering system (prior to 2007) are hereby updated to the new drawing numbers. Refer to sheets 000-205-01 through 000-205-07 to find new drawing numbers when looking for references to older drawing numbers. "Old sheet numbers" are also visible on the website when using the full set of drawings "current" search and are sortable by clicking the header "Old Sheet #" on the results page. Be aware that some older drawings now span over multiple pages due to detailing changes.

(10) DIVISION 100: IMMINENT STANDARD DRAWINGS:

On the Standard Drawings search page, enter status of Imminent with other fields blank to see a list of upcoming Standard Drawings and their corresponding effective let date. Imminent drawings may be used at any time they are available if approved by the Resident. Follow procedure shown in imminent drawings when noted in this section.

No imminent drawings are currently required on this project, but contractor is encouraged to review available imminent drawings for bidding upcoming projects.

(11) DIVISION 100: STANDARD DRAWING ERRATA:

The Bidders are hereby advised that the following note changes apply to the published Standard Drawings.

On sheet **000-205-05**, add the following information under the columns below:

OLD DRAWING NAME	NEW DRAWING NAME
720-905-01 to 720-905-05	720-901-01 to 720-993-32

On sheet **605-005-05 (ver 1-1-2013)**, replace entire text of General Note #4 with the following text:

4. The square footage of sign panels attached to 2½" x 2½" 12 gauge sign support secured to a 3" x 3" 7 gauge breakaway anchor shall not exceed 20 square feet.

On sheet **610-005-00 (ver 5-1-18)** added the following definition to Note 1 of Flagging Operations section:

SIDE ROAD FLAGGER – This flagger is stationed on an intersecting side road and controls the side road traffic entering into the roadway where the work activity area is located.

On sheet **610-005-20 (ver 5-1-18)** added Note 5 :

SPECIAL PROVISIONS

5. When the work proceeds through a “STOP sign controlled” “SIDE ROAD” intersection continue the work operations through the intersection to a specific location point within the “DEPARTURE LANE” no less than 300 FT to 500 FT beyond the limits of the intersection to allow the work train and all portions of the lane closure to clear the intersection.

On sheet **610-005-20 (ver 5-1-18)**

Added dimension “300’-500” for the work activity area after the intersection.

On sheet **610-005-30 (ver 5-1-18)** added Note 5 :

5. When the work proceeds through a “STOP SIGN CONTROLLED” intersection continue the work operations through the intersection to a specific location point within the “DEPARTURE LANE” no less than 300 FT to 500 FT beyond the limits of the intersection to allow the work train and all portions of the lane closure to clear the intersection.

On sheet **610-005-40 (ver 5-1-18)** added Note 5 :

5. When the work proceeds through a “TRAFFIC SIGNAL CONTROLLED” intersection continue the work operations through the intersection to a specific location point within the “DEPARTURE LANE” no less than 300 FT to 500 FT beyond the limits of the intersection to allow the work train and all portions of the lane closure to clear the intersection.

On sheet **610-005-50 (ver 5-1-18)** added Note 5 :

5. When the work proceeds through a “TRAFFIC SIGNAL CONTROLLED” intersection continue the work operations through the intersection to a specific location point within the “DEPARTURE LANE” no less than 300 FT to 500 FT beyond the limits of the intersection to allow the work train and all portions of the lane closure to clear the intersection.

On sheet **610-005-60 (ver 5-1-18)** Title block changed :

Title block now reads “Flagging Operations – Work Zones Beginning @ Intersections with Two-Lane Two-Way Roadways – Departure Lane.”

On sheet **610-005-70 (ver 5-1-18)** Title block changed :

Title block now reads “Flagging Operations – Work Zones Terminating @ Intersections with Two-Lane Two-Way Roadways – Approach Lane.”

On sheet **610-005-80 (ver 5-1-18)** Note 6 revised:

6. Dependent upon the location of the work zone in the “Departure Lane” or the “Approach Lane” of the two-lane two-way road, when the work zone progresses to a location that requires conversion from this flagging operation traffic control setup to a standard flagging operation traffic control setup or vice versa, comply with the requirements of Standard Drawing No. 610-005-60 or Standard Drawing No. 610-005-70 as necessary regarding these conversions.

On sheet **610-005-90 (ver 5-1-18)** Note 6 revised:

6. Dependent upon the location of the work zone in the “Departure Lane” or the “Approach Lane” of the two-lane two-way road, when the work zone progresses to a location that requires conversion from this flagging operation traffic control setup to a standard flagging operation traffic control setup or vice versa, comply with the requirements of Standard Drawing No. 610-005-60 or Standard Drawing No. 610-005-70 as necessary regarding these conversions.

SPECIAL PROVISIONS

In Section 714-000 – Pipe Culverts (Permanent) (ver January 2011)

Delete and replace all references to P1 Biaxial Geogrid with B4 Geogrid on all Drawings within this Section of the Standard Drawings.

On sheet 720-305-00 (ver May 2008), delete the entire note directly above main detail:

On sheet 720-405-00 (ver May 2009) Detail 2 replace dimension 2'-6" maximum with:

2'-6" minimum

On sheet 720-901-01 (ver Feb 2015) replace note 5.04 with:

5.04 When a mid-block crossing is required, consider mid-block staggered crossing (720-955-41) to encourage eye contact between the pedestrian and the oncoming traffic. Always angle the stagger so that the pedestrian travels through the refuge facing the oncoming traffic.

On sheet 722-305-00 (ver May 2010) Detail 4 replace note "French Drain see note 21" with:

French Drain see note 4.5.

On sheet 722-305-00 (ver May 2010) table 722-305A, 4th column, change the following:

Delete (SF)

Replace text "up to 36" with "up to 3'X3' "

Replace text "larger than 36" with "larger than 3'X3' "

On sheet 722-305-00 (ver May 2010) change general note 3.3 2nd sentence & Detail 4:

Place Class 2 Type C Geotextile for Erosion Control under riprap as specified in SCDOT Standard Specification.

On sheet 804-105-00 (ver May 2008) Title Block replace text "Rirap (Bridge End)" with:

Riprap (Bridge End)

On sheet 804-105-00 (ver May 2008) Change Note 2: Geotextile Pay Item to:

8048210 Geotextile for Erosion Control under riprap (Class 2) Type C.... SY

On sheet 804-205-00 (ver May 2009) Change Note 2: Geotextile Pay Item to:

8048210 Geotextile for Erosion Control under riprap (Class 2) Type C.... SY

On sheet 804-305-01 (ver Jul 2017) Change Note 4: Geotextile Pay Item to:

8048210 Geotextile for Erosion Control under riprap (Class 2) Type C.... SY

On sheet 804-305-02 (ver Jul 2017) Change Section A: Geotextile Note to:

Geotextile for Erosion Control under riprap (Class 2) Type C

On sheet 804-310-00 (ver Jul 2017) Change Note 3: Geotextile Pay Item to:

8048210 Geotextile for Erosion Control under riprap (Class 2) Type C.... SY

On sheet 805-001-01 Jan 2019 version, replace note 25.06 with:

SPECIAL PROVISIONS

25.06 FOR PROJECTS THAT SPECIFY PREMASH DEVICES (W-BEAM, TYPE T, TBBC, TYPE B, ETC.) INSTALL W-BEAM RAIL HEIGHT AT 29" +/- 1" (PREVIOUSLY NOTED AS 27.75" +3"/-0".)

On sheet **805-220-00** (ver Jul 2018) replace note 5:

FOR SITES WITH BRIDGES, BOLT GUARDRAIL TO BRIDGE PARAPET AS REQUIRED IN STIFFNESS TRANSITION, AND HOLD FACE OF GUARDRAIL POSITION (TYPICALLY 5'-3" FROM FACE OF CURB) THROUGH STIFFNESS TRANSITION. Make any necessary adjustments to face of guardrail within the LONGITUDINAL BARRIER. INSTALL END TREATMENT so that impact head is beyond the back of sidewalk.

On website, drawings between 805-500-00 and 805-779-99 are reserved as PREMASH standards. Do not value engineer or otherwise substitute PREMASH devices in any location where it has been determined that MASH devices fit and are specified. If MASH devices do not fit site condition, install PREMASH only upon approval by the Resident Engineer. Note that during MASH implementation, some PREMASH details may be published with old drawing numbering and a cover sheet that addresses drawing and pay item changes.

On sheets **805-860-xx (05, 10, 15, 20, 24, 30)** (ver Jan 2016):

All references to toe drain details are revised to refer to drawing 805-875-10 (correct all notes pointing to drawings 805-895-00 or other incorrect drawing numbers.)

(12) SECTION 103.8: CONTRACTOR'S LIABILITY INSURANCE:

Section 103.8 is hereby deleted and replaced with the requirements of SECTION 00100, Item #29 of this Project Manual.

(13) SECTION 105: CONSTRUCTION STAKES, LINES, AND GRADES:

Section 105.8.2 applies to this project. Payment for this work shall be made according to the following schedule:

Percent Contract Complete	Percent of Stakes, Lines, and Grades bid amount to be paid
1-5	20
6-15	40
16-29	60
30-49	70
50-69	80
70-89	90
90-100	100

(14) SECTION 106: QUALIFIED PRODUCT LISTINGS

All references to "Approval Sheet" or "Approval Policy" are to be replaced with "Qualified Products Listings (QPL)" and "Qualified Products Policies (QPP)" respectively. This change includes all references in the SCDOT Standard Drawings, SCDOT Standard Specifications, SCDOT Supplemental Specifications, SCDOT Special Provisions, SCDOT Supplemental Technical Specifications, SCDOT Internet and Intranet websites, and all other documents produced by SCDOT.

(15) CONSTRUCTION SCHEDULE

See Attached Supplemental Specification CONSTRUCTION SCHEDULES Dated November 4, 2013.

This project will have a Level 1 Schedule.

(16) SECTION 106: SOUTH CAROLINA MINING ACT:

See Attached Supplemental Specification Dated **March 20, 2003**. This Supplemental Specification is hereby modified as follows:

SPECIAL PROVISIONS

Paragraph 9 is hereby deleted and replaced with the following:

The deputy secretary for engineering, or his duly appointed representative, will make a final inspection of the reclaimed area and keep a permanent record of his approval thereof. A map or sketch providing the location and approximate acreage of each pit used on the project will be provided to the resident construction engineer for inclusion in the final plans.

The last paragraph is hereby deleted and replaced with the following:

The contractor shall comply with the provisions of the plan that are applicable to the project as determined by the engineer. Seeding or other work necessary to comply with the plan on pits furnished by the contractor shall be at the expense of the contractor. Seeding shall be in accordance with SC-M-810 (latest version) which can be found at <https://www.scdot.org/business/road-technical-specs.aspx>.

(17) SECTION 107: PROJECT BULLETIN BOARDS:

In accordance with the Required Contact Provisions Federal-Aid Construction Contracts Section II, Item 3, Part d, add the following:

Single Location Projects – On projects in which work is performed at a single location (such as bridge replacement projects, two-lane to five-lane widening projects, etc.), mount the project bulletin board in a permanent location within the project limits so that it is visible and accessible at all times.

Multiple Location Projects – On projects in which work is being performed or has the capability of being performed at multiple locations (such as resurfacing projects, pavement marking projects, etc.), display a portable bulletin board with at least one of the prime contractor's work crews. If the prime contractor is not performing work, display the portable bulletin board with at least one of the subcontractor's work crews. Display the portable bulletin board in a location and a manner that is acceptable to the RCE. Notify the RCE and all subcontractors as to the location of the portable bulletin board. On resurfacing projects, mount an additional project bulletin board in a permanent location at the asphalt plant supplying asphalt mix to the project so that it is visible and accessible at all times.

(18) SECTION 107: FAIR LABOR STANDARDS ACT OF 1938, AS AMENDED:

Attention is directed to this Federal Legislation, which has been enacted into law. The contractor will be responsible for carrying out all of the provisions of this legislation, which may affect this contract.

(19) SECTION 107: APPLICATION OF DAVIS-BACON AND RELATED ACTS TO INDEPENDENT TRUCK DRIVERS AND MISCELLANEOUS CONSTRUCTION ACTIVITIES:

See attached Supplemental Specification dated **June 13, 1990** on page Error! Bookmark not defined..

(20) SECTION 107: REQUIREMENTS FOR FEDERAL AID CONTRACTS WHICH AFFECT SUBCONTRACTORS, DBE HAULERS, MATERIAL SUPPLIERS AND VENDORS:

See attached Supplemental Specification dated **July 1, 2021**.

(21) SECTION 107: CARGO PREFERENCE ACT REQUIREMENTS:

(a) Use of United States-flag vessels – General Provisions:

"(1) Pursuant to Pub. L. 664 (43 U.S.C. 1241(b)) at least 50 percent of any equipment, materials or commodities procured, contracted for or otherwise obtained with funds granted, guaranteed, loaned, or advanced by the U.S. Government under this agreement, and which may be transported by ocean vessel, shall be transported on privately owned United States-flag commercial vessels, if available.

SPECIAL PROVISIONS

"(2) Within 20 days following the date of loading for shipments originating within the United States or within 30 working days following the date of loading for shipments originating outside the United States, a legible copy of a rated, 'on-board' commercial ocean bill-of-lading in English for each shipment of cargo described in paragraph (a)(1) of this section shall be furnished to both the Contracting Officer (through the prime contractor in the case of subcontractor bills-of-lading) and to the Division of National Cargo, Office of Market Development, Maritime Administration, Washington, DC 20590."

(b) Use of United States-flag vessels - The contractor agrees:

"(1) To utilize privately owned United States-flag commercial vessels to ship at least 50 percent of the gross tonnage (computed separately for dry bulk carriers, dry cargo liners, and tankers) involved, whenever shipping any equipment, material, or commodities pursuant to this contract, to the extent such vessels are available at fair and reasonable rates for United States-flag commercial vessels.

"(2) To furnish within 20 days following the date of loading for shipments originating within the United States or within 30 working days following the date of loading for shipments originating outside the United States, a legible copy of a rated, 'on-board' commercial ocean bill-of-lading in English for each shipment of cargo described in paragraph (b) (1) of this section to both the Contracting Officer (through the prime contractor in the case of subcontractor bills-of-lading) and to the Division of National Cargo, Office of Market Development, Maritime Administration, Washington, DC 20590.

"(3) To insert the substance of the provisions of this clause in all subcontracts issued pursuant to this contract."

(22) SECTION 107: IRAN DIVESTMENT ACT:

By submission of this bid/proposal, the bidder/proposer as the prime contractor/consultant/vendor does hereby certify his compliance to the following:

1. CERTIFICATION: (a) The Iran Divestment Act List is a list published pursuant to Section 11-57-310 that identifies persons engaged in investment activities in Iran. Section 11-57-310 requires the government to provide a person ninety days (90) written notice before he is included on the list. The following representation, which is required by Section 11-57-330(A), is a material inducement for the SCDOT to award a contract to you. (b) By signing your Offer, you certify that, as of the date you sign, you are not on the then-current version of the Iran Divestment Act List. (c) You must notify the SCDOT immediately if, at any time before posting of a final statement of award, you are added to the Iran Divestment Act List.

2. ONGOING OBLIGATIONS: (a) You must notify SCDOT immediately if, at any time during the contract term, you are added to the Iran Divestment Act List. (b) Consistent with Section 11-57-330(B), you shall not contract with any person to perform a part of the Work, if, at the time you enter into the subcontract, that person is on the then-current version of the Iran Divestment Act List.

3. OPTION TO RENEW RESTRICTION: Contractor acknowledges that, unless excused by Section 11-57-320, if the contractor is on the then-current Iran Divestment Act List as of the date of any contract renewal, the renewal will be void ab initio.

(23) SECTION 107: LATE DISCOVERY OF ARCHAEOLOGICAL/HISTORICAL REMAINS ON FEDERAL AID PROJECTS AND APPROVAL OF DESIGNATED BORROW PITS:

See attached Supplemental Specification dated **August 7, 1991**.

If archaeological materials are encountered during construction, the procedures codified at 36 CFR 800.13(b) will apply and the SC Department of Archives and History and the EDA shall be contacted immediately. Archaeological materials consist of any Items, fifty years old or older, which were made or used by man. These items include, but are not limited to, stone projectile points

SPECIAL PROVISIONS

(arrowheads), ceramic sherds, bricks, worked wood, bone and stone, metal and glass objects, and human skeletal materials.

(24) SECTION 107: CRANE SAFETY:

See attached Supplemental Specification dated August 1, 2013.

(25) SECTION 107: REQUIRED MEDIA NOTIFICATION FOR CONSTRUCTION PROJECTS:

Contractors are encouraged to co-operate with the news media since all projects are constructed with public funds. Because the scope of this project will cause disruption of normal traffic flow, the Contractor is required to notify the public, in a timely manner, of disruptive activities such as lane closures.

The Contractor is required to utilize area media to accomplish public notification of traffic disruptions.

The Contractor is required to deal directly with the news media and all reasonable efforts should be made to co-operate with the media. However, the safety, security and construction schedule on site should not be disrupted in order to accomplish this.

(26) SECTION 107: CONTRACT PROVISION TO REQUIRE CERTIFICATION AND COMPLIANCE CONCERNING ILLEGAL ALIENS

By submission of this bid, the bidder as the prime contractor does hereby agree:

- a. to certify its compliance with the requirements of Chapter 14 of Title 8 of the S.C. Code of Laws regarding Unauthorized Aliens and Public Employment;
- b. to provide SCDOT with any documents required to establish such compliance upon request; and
- c. to register and participate and require agreement from subcontractors and sub-subcontractors to register and participate in the federal work authorization program to verify the employment authorization of all new employees, or to employ only workers who supply the documents required pursuant to S.C.Code 8-14-20(B)(2).

(27) SECTION 208: FINE GRADING:

See attached Supplemental Specification Dated **January 4, 2012**.

(28) SECTION 305: MAINTENANCE STONE:

Maintenance Stone used on this project shall conform to the gradation requirements of Section 305, or to the gradation specified for Aggregate No. CR-14 in the Standard Specifications.

(29) DIVISION 600: MANUAL ON UNIFORM TRAFFIC CONTROL DEVICES:

The Contractor is advised that all work involving design or installation of traffic control devices, including but not limited to signs, pavement markings, elements of work zone traffic control, signals, etc., shall be in compliance with the FHWA's Manual on Uniform Traffic Control Devices (MUTCD), latest edition. The latest edition is defined as the edition that the Traffic Engineering Division of SCDOT recognizes as having been officially adopted (Engineering Directive, Memorandum 19) at the time the project is let, unless stated otherwise in the Special Provisions.

(30) DIVISION 600: TRAFFIC CONTROL:

See attached Supplemental Specification dated **July 1, 2019**.

(31) SECTION 602: GENERAL REQUIREMENTS FOR PROVIDING AND MAINTAINING TRAFFIC CONTROL DEVICES IN THE WORK ZONE:

Delete **Section 602.1.11**.

(32) SECTION 602: PERMANENT CONSTRUCTION SIGNS:

SPECIAL PROVISIONS

Utility locations must be performed prior to the placement of Permanent Construction Signs. State Law requires that the location of each sign be marked with a white line in the roadway or a stake in the shoulder. The locator company will mark 25 feet on either side of the location. The responsibility for marking the sign locations prior to the contractor calling PUPS for utility locate lies with the party responsible for lines and grades on the project. If Construction Lines and Grades is a pay item, then the Prime Contractor is responsible for marking the sign location. If this is not included, it is the Department's responsibility to mark the locations.

Prior to marking the sign location, care must be taken when marking the signs to ensure that there are no obstructions or other mitigating factors that will cause the sign to be moved outside of the 50 foot utility window. Any costs associated with staking out the sign locations are considered incidental to the cost of Permanent Construction Signs.

Requests for utility locates must be specific and isolated to the sign locations if no ground disturbing activities are occurring outside of the sign placement.

(33) SECTION 610: WORK ZONE TRAFFIC CONTROL PROCEDURES:

The first sentence of Section 610.3 of the 2007 Standard Specifications is hereby revised to:

"Ensure that background color of personal protective apparel is either fluorescent Yellow-Green or fluorescent Orange-Red, and meets ANSI Standard 107-2004 National Standard for High Visibility Apparel Class 2 (or Class 3 as necessary) Performance Criteria, or latest edition."

Note #12 of Standard Drawing 610-005-00 is hereby revised to:

"During nighttime flagging operations, flaggers shall wear a Safety Vest and Safety Pants meeting ANSI Standard 107-2004 National Standard for High Visibility Apparel Class 3 Performance Criteria, or Latest Edition, and a Hardhat. The color of the apparel background material shall be either fluorescent Yellow-Green or fluorescent Orange-Red."

(34) SECTION 815: EROSION CONTROL MEASURES:

See attached Supplemental Specification dated **January 1, 2020**.

(35) EXCAVATED MATERIALS

No excavated material shall be placed within areas of mapped 100-year or 500-year floodplain.

(36) PROMPT PAYMENT CLAUSE:

See attached Supplemental Specification Dated **June 14 2000**.

Paragraph 2 of the Supplemental Specification shall be updated as below.

"The Contractor may withhold as retainage up to **ten (10%)** percent of a subcontractor's payment until satisfactory completion of all work items of the subcontract. "Satisfactorily completion of all work items of the subcontract" shall mean when the SCDOT pays the Contractor for the last work item of the subcontract. The Contractor must release to the subcontractor any retainage withheld within seven (7) calendar days from the date the Contractor receives payment from SCDOT for the last work item of the subcontract"

(37) EDA REQUIRED SPECIFICATION DOCUMENTS

See attached Appendix A. There shall be no additional compensation for these requirements.

January 1, 2018

ERRATA TO 2007 STANDARD SPECIFICATIONS FOR HIGHWAY CONSTRUCTION

Make the changes listed below to correct errata in the SCDOT *2007 Standard Specifications for Highway Construction*:

DIVISION 100 GENERAL PROVISIONS

SECTION 101 DEFINITIONS AND TERMS

Subsection 101.2 Abbreviations and Acronyms

Amend the table of **SCDOT OFFICIALS AND OFFICES** as follows:

DELETIONS		REPLACEMENTS	
BDE*	Bridge Design Engineer	PSE*	Preconstruction Support Engineer
BDGE*	Bridge Design Geotechnical Engineer	GDSE*	Geotechnical Design Support Engineer
SHE*	State Highway Engineer	DSE*	Deputy Secretary for Engineering

*Wherever it appears in the text, replace the deleted abbreviation with the new abbreviation.

SECTION 102 BIDDING REQUIREMENTS AND CONDITIONS

Subsection 102.8 Irregular Bids

Paragraph 2, item E, first sentence; delete the word "the" after the word "When".

SECTION 105 CONTROL OF WORK

Subsection 105.6 Cooperation with Utilities

Paragraph 1, last sentence; change the word "THE" to "the".

DIVISION 200 EARTHWORK

SECTION 202 REMOVAL OF STRUCTURES AND OBSTRUCTIONS

Subsection 202.5 Measurement

Paragraph 5, second bullet; change the words "Brick sidewalk" to "Concrete, brick or stone sidewalks".

SECTION 204 STRUCTURE EXCAVATION

Subsection 204.2.1.2 Structure Excavation for Culverts

Paragraph 1, at the end of the first sentence; change "**Subsection 204.4**" to "**Subsection 204.5**".

DIVISION 400 ASPHALT PAVEMENTS

SECTION 401 HOT MIXED ASPHALT (HMA) PAVEMENT

Subsection 401.2.1.2 Liquid Anti-Stripping Agent

Paragraph 1, first sentence; delete the period at the end of the sentence and add "and SC-M-406."

Subsection 401.2.5 Material for Full Depth Patching

Paragraph 1, delete and replace with the following:

"Use an approved SCDOT Intermediate Type C mix for all Full Depth Patching."

SUPPLEMENTAL SPECIFICATIONS

Subsection 401.5 Measurement

After paragraph 10, add the following paragraph:

- 11 The measurement of Prime Coat is the number of gallons of asphalt material applied to the completed and accepted base course.

Subsection 401.6 Payment

After paragraph 12, add the following paragraph:

- 13 "The payment for Prime Coat is at the contract unit price for Prime Coat and includes compensation for all labor, equipment, tools, maintenance, and incidentals necessary to complete that work."

Subsection 401.6 Payment

Paragraph 13, **Table of Pay Items**

Change paragraph reference number "13" to "14" and add the following Pay Item:

Item No.	Pay Item	Unit
4010005	Prime Coat	GAL

SECTION 403 HMA SURFACE COURSE

Subsection 403.5 Measurement

Paragraph 1, first sentence; change "HMA Intermediate Course" to "HMA Surface Course".

Subsection 403.6 Payment

Paragraph 1, first sentence; change "HMA Intermediate Course" to "HMA Surface Course".

SECTION 407 ASPHALT SURFACE TREATMENT – DOUBLE TREATMENT

Subsection 407.5 Measurement

Paragraph 1, first sentence; add the word "is" after "(Double Treatment Type (1, 2, 3, 4, or 5))".

SECTION 408 ASPHALT SURFACE TREATMENT – TRIPLE TREATMENT

Subsection 408.5 Measurement

Paragraph 1, first sentence; add the word "is" after "(Triple Treatment Type (1 or 2))".

DIVISION 600 MAINTENANCE AND TRAFFIC CONTROL

**SECTION 625 PERMANENT PAVEMENT MARKINGS
FAST DRY WATERBOURNE PAINT**

Subsection 625.2.2.4.11 Lead Content

Paragraph 1, first sentence; change 6% to 0.06%.

SECTION 627 THERMOPLASTIC PAVEMENT MARKINGS

Subsection 627.4.10 Inspection and Acceptance of Work

Paragraph 2, first sentence; change "period of 90 days" to "period of 180 days".

Subsection 627.4.10 Inspection and Acceptance of Work

Paragraph 2, second sentence; change "90-day observation period" to "180-day observation period".

Subsection 627.4.10 Inspection and Acceptance of Work

Paragraph 3, first sentence; change "90-day period" to "180-day period".

DIVISION 700 STRUCTURES**SECTION 709 STRUCTURAL STEEL****Subsection 709.4.3.5.2 Submittals and Notification**

Paragraph 1, delete the last two sentences and replace them with, "The Department's review and acceptance are required before any field welding will be permitted."

Subsection 709.6.3 Pay Items (page 650)

Subsection heading number; change subsection heading number from "709.6.3" to "709.6.4".

SECTION 712 DRILLED SHAFTS AND DRILLED PILE FOUNDATIONS**Subsection 712.4.4 Dry Construction Method**

Paragraph 2, last sentence in A; change "*Drilled Shaft Report*" to "*Drilled Shaft Log*".

Subsection 712.4.10.4 Excavation Cleanliness

Paragraph 1, last sentence; change "*Drilled Shaft Report*" to "*Drilled Shaft Log*".

Subsection 712.4.10.6 Shaft Load Test

Change first paragraph reference number from "2" to "1".

Subsection 712.6.10 Drilled Pile Set-Up

Insert paragraph reference number "1" to the left of the first paragraph.

SECTION 723 DECK JOINT STRIP SEAL**Subsection 723.1 Description**

Insert paragraph reference number "3" to the left of the third paragraph.

SECTION 726 BRIDGE DECK REHABILITATION**Subsection 726.4.1 General**

Insert paragraph reference number "1" to the left of the first paragraph.

Subsection 723.4.6 Full Depth Patching (page 790)

Subsection heading number; change subsection heading number from "723.4.6" to "726.4.6"

Subsection 726.6.8 Concrete Overlay (Latex) or (Portland Cement) (page 802)

Paragraph 2, the equation is changed to $AP=CP \times (ACS/RCS) ^ 2$

SECTION 727 CROSSHOLE SONIC LOGGING OF DRILLED SHAFT FOUNDATIONS**Subsection 726.6 Payment (page 807)**

Subsection heading number; change subsection heading number from "726.6" to "727.6"

DIVISION 800 INCIDENTAL CONSTRUCTION**SECTION 805 GUARDRAIL****Subsection 805.5 Measurement**

Paragraph 4; amend as follows:

SUPPLEMENTAL SPECIFICATIONS

"The quantity for the pay item 8053000 Additional Length Guardrail Post is the length of required post installed in excess of the standard length post based on the system being installed, measured by the linear foot (LF), complete, and accepted."

SECTION 815 EROSION CONTROL

Subsection 815.1 Description

Paragraph 1, first sentence; change "temporary flexible pipe" to "temporary pipe".

Subsection 815.5 Measurement

Paragraph 13; delete the first sentence and replace it with the following sentence:
"The quantity for Temporary Pipe Slope Drains is measured and paid for in accordance with **Subsections 803.5** and **803.6** respectively."

Subsection 815.5 Measurement

Delete paragraph 19.

Subsection 815.6 Payment

After paragraph 15, add the following paragraph:

- 16 Payment for Removal of Silt Retained by Silt Fence is full compensation for removing and disposing of sediment deposits accumulated by silt fences as specified or directed and includes all materials, labor, equipment, tools, supplies, transportation, and incidentals necessary to fulfill the requirements of the pay item in accordance with the Plans, the Specifications, and other terms of the Contract.

Subsection 815.6 Payment

Change original paragraph number "16" to "17".

Subsection 815.6 Payment

Pay Item table; change the Unit for Item No. 8156214 to "EA".

INDEX:

Amend as follows:

Page I-3, after "Bridge Deck Rehabilitation, measurement and payment:"

Delete page 807.

Page I-12, after "Letting:"

Replace page 19 with page 9.

Page I-13, after "Overhead Sign Structure:"

Replace page 488 with page 495.

Page I-15, after "Proof Rolling:"

Delete page 98.

Page I-18, after "Structural Steel, turned and ribbed bolts:"

Replace page 624 with page 625.

Page I-19, after "Waterproofing, bridge deck:"

Delete page 907.

Page I-20, after "Working Drawings:"

Replace page 543 with page 779.

March 20, 2003

THE SOUTH CAROLINA MINING ACT

The South Carolina Mining Act enacted by the General Assembly in 1973 requires that the Department adopt reclamation standards to govern activities of the Department and any person acting under contract with the Department, on highway rights-of-way or material pits maintained solely in connection with the construction, repair and maintenance of the public road systems in South Carolina.

**STANDARD PLAN FOR THE RECLAMATION OF EXCAVATED AREAS ADOPTED BY
THE SOUTH CAROLINA DEPARTMENT OF TRANSPORTATION**

Reclamation plans as stated herein shall include all areas disturbed in excavations of borrow and material pits, except planned inundated areas.

The final side slopes of areas excavated for borrow and material pits shall be left at such an angle so as to minimize erosion and the possibility of slides. The minimum slope in every case shall be not less than 3:1.

Small pools of water that are, or are likely to become noxious, odious, or foul should not be allowed to collect or remain on the borrow pit. Suitable drainage ditches, conduits, or surface gradient shall be constructed to avoid collection of noxious, odious, or foul pools of water unless the borrow pit is to be reclaimed into a lake or pond.

Borrow pits reclaimed to a lake or pond must have an adequate supply of water to maintain a water sufficient level to maintain a minimum water depth of four (4) feet on at least fifty (50) percent of the surface area of the lake or pond.

Excavated areas will be drained where feasible unless otherwise requested by the property owner where, in such instances, the property owner may wish to develop the excavated area for recreational purposes or for the raising of fish, or for other uses, in compliance with the South Carolina Mining Act.

Where material is stripped from the ground surface in relatively thin layers, the area, after excavation has been completed, will be thoroughly scarified and terraced and planted to establish satisfactory vegetation necessary to control erosion. Vegetative cover should be established on a continuing basis to ensure soil stability appropriate to the area. Conservation practices essential for controlling both on-site and off-site erosion and siltation must be established. A minimum of seventy-five (75) percent vegetative ground cover, with no substantial bare spots, must be established and maintained into the second growing season.

Excavated areas that are drained will be seeded to obtain a satisfactory vegetative cover. The side slopes of excavated area will be planted to vegetation.

The State Highway Engineer, or his duly appointed representative, will make a final inspection of the reclaimed area and keep a permanent record of his approval thereof. A map or sketch providing the location and approximate acreage of each pit used on the project will be made available to the Final Plans Engineer.

All applicable regulations of agencies and statutes relating to the prevention and abatement of pollution shall be complied with by the contractor in the performance of the contract.

The Contractor shall comply with the provisions of the Plan which are applicable to the project as determined by the Engineer. Seeding or other work necessary to comply with the plan on pits furnished by the contractor shall be at the expense of the contractor. Bermuda shall not be planted on ground surface pit areas. The quantity of fescue seed specified in Subsection 810.04 of the Standard Specifications shall be increased by fifteen (15) pounds in lieu of the deleted bermuda seed.

November 4, 2009

AS-BUILT CONSTRUCTION PLANS

GENERAL

The Contractor shall produce and deliver to the Department the final As-Built plans for this contract. This set of As-Built plans is not intended to document final quantities, but is intended to show approved revisions to the contract design including but not limited to: revised roadway profiles and cross sections, revised typical sections, revised drainage installations, any changes to the demolition and removal items and any other changes to the original design.

If any design changes occur during construction, the plan sheets (or any other "job site record document" with a seal) revised after award of contract shall include a complete accounting and detail of the revisions and design changes. The P.E. responsible for the revisions shall seal each altered plan sheet (or any other "job site record document" with a seal). This documented information is to be part of the As-Built Plan requirements.

The As-Built plans shall be neat, legible and of the correct size. Bridge projects and any road projects which include Plan, Profile and Cross-Section Sheets shall be full size. In general, if the job was let with full size plans (22" X 36"), the As-Built shall be full size. All revisions to the original plans shall be delineated in red, located properly on the drawing, they shall be legible and true to scale. Every As-Built Plan, Profile and Cross-section Sheet shall be designated as such by note or stamp "As-Built" in black. The As-Built plans shall be bound in the same manner as they were let, not combined. In other words, if a project includes road and bridge work and each is bound separately, keep them separate for As-Built, each with its own AB201 cover sheet.

In submitting As-Built plans, the Contractor, or person responsible for the work, shall be required to complete FORM AB205 or AB206 whichever is applicable, and submit the form with the required deliverables to the RCE. The items and notes on these forms that apply to this project establish the minimum requirements for As-Built Plans. The forms can be found on the SCDOT website at <http://www.scdot.org/doing/default.html>.

Changes to the state highway system by any outside agency also need to have their plans placed in the Plans Library for future reference. This includes but is not limited to: encroachment permit projects, enhancements, procurements, inter-governmental agreements (IGA), local public agency (LPA) projects and any other agency, private or public, making changes to the existing state highway system. When AsLet plans are provided, the person or agency responsible for the work shall supply the SCDOT As-Built Plans Office in headquarters a set of As-Built plans which meet the requirements of this specification. Regardless of whether or not as-let plans are provided, when any changes are made to or within existing ROW, the as-built plans office is to be notified so the changes can be documented in the plans library. Once notified, the as-built engineer and the person responsible for the work can determine what will best represent the work performed in the field. The as-built engineer will review and forward to the Plans Storage Office for archiving.

The final As-Built plans shall be submitted within forty-five (45) days following the substantial work complete date of the project.

CRANE SAFETY

The contractor's attention is directed to the following Crane Safety criteria. All applicable items under the submittal list section shall be submitted to the Resident Construction Engineer (RCE) before any crane operations may begin. If any personnel or equipment is changed or added, all applicable items shall be updated and submitted to the RCE before continuing with crane(s) operations.

All contractors shall comply with the manufacturer specifications and limitations applicable to the operation of any and all cranes and derricks. Prime contractors and sub-contractors shall comply with the latest Occupational Safety and Health Administration (OSHA) regulations, adopted American National Standards Institute (ANSI) and American Society of Mechanical Engineers (ASME) crane standards, and other applicable standards including, but not limited to the following:

- OSHA 29 CFR 1926 Subpart CC "Cranes and Derricks in Construction"
- OSHA 29 CFR 1926.251 "Rigging Equipment for Material Handling"
- ASME B30.5-2007 "Mobile and Locomotive Cranes"
- ASME B30.8-2010 "Floating Cranes and Floating Derricks"
- ASME B30.22-2005 "Articulating Boom Cranes"
- ASME B30.26-2010 "Rigging Hardware"

Submittal List

1. **Crane Operators:** All crane operators shall be certified by the National Commission for the Certification of Crane Operators (NCCCO), National Center for Construction Education and Research (NCCER), or Crane Institute of America Certification (CIC).
 - a. Contractor shall submit a copy of the NCCCO, NCCER, or CIC certification for each crane operator prior to performing any crane operations on the job site. The original certification card shall be available for review upon request and must remain current within a 5 year expiration date for the duration of the job. (Contractors with a crane operator-in- training on the jobsite shall comply with all the OSHA Subpart CC requirements).
 - b. Contractor shall submit a copy of the current Crane Operators Medical Evaluation card (3 year expiration) in the form of NCCCO, NCCER or CIC Physical Examination form or equivalent meeting the ASME B30.5 requirement or a current USDOT Medical Examiner's Certificate card (2 year expiration). The original medical card or equivalent for all crane operators shall be available for review upon request.
2. **Competent Person:** The named competent person will have the responsibility and authority to stop any work activity due to safety concerns.
 - a. Contractor shall submit the name and qualifications of the "Competent Person" as defined by OSHA Subpart CC responsible for all crane safety and lifting operations.

June 13, 1990

APPLICATION OF DAVIS-BACON AND RELATED ACTS TO INDEPENDENT TRUCK DRIVERS AND MISCELLANEOUS CONSTRUCTION ACTIVITIES

The Davis-Bacon and Related Acts apply when:

- 1) A Contractor or Subcontractor hires a trucking firm or fleet of trucks to haul materials from a plant, pit, or quarry, which has been established specifically to serve (or nearly so) a particular project or projects covered by Davis-Bacon and Related Acts.
- 2) A Contractor or Subcontractor hires a trucking firm or fleet of trucks to haul material from a non-commercial stockpile or non-commercial storage site outside the limits of the project to the project site.
- 3) A Contractor or Subcontractor hires a trucking firm or fleet of trucks to haul excavated materials away from a Davis-Bacon covered project.
- 4) A contractor or Subcontractor rents or leases equipment with an operator to perform work as called for under a Davis-Bacon construction contract.
- 5) A common carrier is used for the transportation of materials from an exclusive material supply facility to fulfill the specific need of a construction contract.

The fleet owner is not considered a Subcontractor with regard to the 70% subcontracting limitations and would not have to be approved as a Subcontractor. However, payrolls must be submitted by truck fleet owner covering the truck drivers, and all requirements such as predetermined wages, overtime, etc., are applicable. Legitimate owner-operators (truck owner driving his own truck) must appear on the payroll by name and notation "truck Owner Operator" with no hours, etc. shown.

The Davis-Bacon and Related Acts do not apply when:

- 1) A Contractor or Subcontractor hires a trucking firm or fleet of trucks to haul materials from a commercial plant, pit, or quarry which had previously been established for commercial use and regularly sell materials to the general public.
- 2) A Contractor or Subcontractor hires a trucking firm or fleet of trucks to haul materials from an established commercial plant, pit, or quarry to a stockpile outside the limits of the project.
- 3) Bona fide owner-operators of trucks, who are independent contractors, use their own equipment to haul materials to or from or on a Davis-Bacon covered project. (One man-One truck)

The fleet owner is not considered a Subcontractor with regard to the 70% subcontracting limitation and would not have to be approved as a Subcontractor.

July 1, 2021

REQUIREMENTS FOR FEDERAL AID CONTRACTS WHICH AFFECT SUBCONTRACTORS, DBE HAULERS, MATERIAL SUPPLIERS AND VENDORS

- A. The Contractor's attention is directed to Form FHWA 1273 that is included in your contract documents as the Supplemental Specification "Required Contract Provisions Federal-Aid Construction Contracts". **This Specification requires that Form FHWA 1273 must be physically incorporated in all Federal Aid Construction Contracts and lower tier subcontracts.** Form FHWA 1273 must be either physically incorporated or incorporated by reference in all purchase orders.
- B. The contractor's attention is directed to the requirements of the Supplemental Specification "Standard Federal Equal Employment Opportunity Construction Contract Specifications" that is included in your contract documents. This specification must be physically included in each subcontract with a value of \$10,000 or greater.
- C. The Contractor's attention is directed to the requirements of the Equal Employment Opportunity Performance certifications in the Proposal Form Certifications and Signatures section of the contract. Subcontractors must answer the three questions in the "Certification (1)" section and the completed form must be physically included in the subcontract agreement.
- D. Prior to the issuance of approval of DBE subcontractors the Contractor must submit a signed copy of the subcontract agreement between the Prime Contractor and the DBE Subcontractor.
- E. Prior to the issuance of approval of DBE haulers the Contractor must submit a signed copy of the hauling agreement.

August 7, 1991

LATE DISCOVERY OF ARCHAEOLOGICAL/HISTORICAL REMAINS ON FEDERAL AID PROJECTS AND APPROVAL OF DESIGNATED BORROW PITS

A. Late Discovery of Archaeological/Historical Remains on Federal Aid Projects.

1. Responsibilities:

The Contractor and subcontractors must notify their workers to watch for the presence of any prehistoric or historic remains, including but not limited to arrowheads, pottery, ceramics, flakes, bones, graves, gravestones, or brick concentrations. If any such cultural remains are encountered, the Resident Construction Engineer shall be immediately notified and all work in the vicinity of the discovered materials or site shall cease until the Department's Staff Archaeologist or the State Highway Engineer directs otherwise.

2. Applicability:

This provision covers all areas of ground disturbance resulting from this federal - aid contract, including but not limited to road construction, Department designated borrow pits, Contractor furnished borrow pits, and/or staging areas.

3. Cost Reimbursement and Time Delays:

Any extra work required by A(1) above within the project right of way or on Department designated borrow pits (see below) will be paid for in accordance with Subsection 104.05 of the Standard Specifications. Extra contract time may be provided under Subsection 108.06 of the Standard Specifications for archaeological work within the project right of way or on designated borrow pits.

NOTE: On Contractor furnished borrow pits the contractor is not entitled to any additional time or money for delay on impact resulting from A(1) above or for extra work required by A(1) above. Therefore, contractors may wish to retain professional archaeological services to better ensure that borrow pit areas are cleared of archaeological/historical remains prior to use on Federal aid projects.

B. Approval of Designated Borrow Pits on Federal Aid Projects (Plant Sites which qualify as commercial are not included).

In instances where the Department specifically designates the location of borrow pits on project plans or in contract specifications for use on a Federal aid project, an archaeological survey will be performed by Department archaeologists prior to award of contract.

This provision also applies to designated disposal sites, staging areas, haul roads, and job site field offices.

November 4, 2013

CONSTRUCTION SCHEDULES

General

This supplemental specification addresses schedule requirements for SCDOT contracts. There are three levels of schedules. The level required is included in the Special Provision. The level of schedule is selected based on the design field review completed in the preconstruction phase or during estimate development.

Level 1 – Minimal Schedule Requirement

Level 2 Schedule – Standard Critical Path Method Schedule

Level 3 Schedule – Critical Path Method Schedule with Monthly Cumulative Payment Clause.

Level 1 Requirement:

Provide to the Resident Construction Engineer (RCE) a four-week look-ahead schedule identifying planned weekly work activities. Update the schedule every two weeks. The look-ahead schedule allows the RCE to schedule construction engineering and inspection personnel. The Department will not be responsible for delays which may be caused by the contractor's failure to abide by his schedule. Failure to submit the look-ahead schedule as specified may result in the withholding of partial payment estimates.

Provide the look-ahead schedule in Word or Excel format or as directed by the RCE.

The Contractor may provide a CPM schedule as indicated in **Level 2 Schedule Requirements** in lieu of the four-week look-ahead schedule as follows:

- Notify, in writing, the RCE that a CPM schedule will be provided in lieu of a four-week look-ahead schedule. Provide timely notification so that the baseline schedule is submitted in accordance with **Level 2 Schedule Requirements - Submission, Review, and Acceptance Process – Baseline Schedule**.
- No payment will be made if the Contractor elects to provide a CPM as a Level I Requirement. **Measurement and Basis of Payment** will be according to the Level I Schedule.
- Election to provide a CPM schedule in lieu of a four-week look-ahead schedule will be for the duration of the project.

Level 2 Schedule Requirements:

For projects requiring a CPM schedule, the Contractor will provide and update a construction schedule to the SCDOT, which will be used as a quantitative basis for:

- Monitoring and evaluating the Contractor's progress in completing contracted work;
- Evaluating requests for additional contract time;
- Budgeting for construction partial payment estimates; and
- Managing SCDOT engineering and inspection personnel.

The Contractor's construction schedule shall encompass the entire contract period, and be developed consistent with the contract milestones and the contract maintenance of traffic plan. Critical path activities shall be identified for the duration of the project. The schedule shall also include sufficient information *as outlined in this supplemental specification* to provide for monetary and quantitative tracking of the work by the SCDOT.

Include and reference in the schedule at the time of occurrence, all documentation and explanations supporting a time adjustment request.

Utilities

SUPPLEMENTAL SPECIFICATIONS

The schedule shall reflect the utility relocations noted in the contract documents and discovered during field review and include activities of appropriate duration, location, and logic, as provided by the Utility, for the utility work. Where utility durations are unknown, the Contractor shall provide a reasonable estimate of duration. Utility durations will be reviewed in the baseline approval process as outlined in the section "Submission, Review, and Acceptance Process." Utility durations will be presented at the Preconstruction Conference for concurrence by the utility provider. In the event that the utility representative cannot provide concurrence at the Preconstruction Conference, the Contractor, the Resident Construction Engineer, and the utility provider shall work diligently to reach acceptable durations. If there is no concurrence or input from the utility provider concerning the Contractor's utility durations within 15 calendar days following the Preconstruction Conference, the submission with the Contractor's estimate of utility duration will be reviewed for baseline acceptance. Further utility duration changes beyond this point in time will be assessed in monthly schedule updates. Failure to include activities for any element of work or any known utility work will not relieve the Contractor from completing the work within the allotted contract time.

Schedule Submissions

Contractors shall maintain CPM schedules for all applicable projects using at a minimum Primavera Project Management 5.0 or Primavera Contractor 5.0. The Contractor shall coordinate with the Department's District Scheduler to provide an exported schedule importable into the Primavera version used by the Department.

Templates for the CPM schedules are available to download at [the](#) the SCDOT construction Extranet site located:

<https://www.scdot.org/business/constructionletting-extranet.aspx>

When submitting schedules to the SCDOT, the Contractor shall assign file names to each schedule file (baseline and updates) according to the following conventions (dates are YYMMDD):

Type of Schedule Submitted:	Baseline	Update	As-Built
File Name Convention:	[Contract ID]b[Data Date]	[Contract ID]u[Data Date]	[Contract ID]ab[Data Date]
File Name Example:	32.82571b060201	32.82571u060201	32.82571ab060201

Note on Data Dates - The initial Baseline Construction Schedule shall have a data date equal to the Award Date and not include any work to date. Monthly schedule updates shall have a data date set 1 day beyond the most recent estimate period end date.

Extranet file names upon uploading shall include the contract ID.

All submissions shall be made within the time frames defined under "Submission, Review and Acceptance Process."

Electronic Files: Upload each baseline construction schedule and monthly update submission to the SCDOT Construction Extranet site in .xer format.

The Extranet site location is:

<https://www.scdot.org/business/constructionletting-extranet.aspx>

Provide an Adobe file of each baseline construction schedule, monthly update submission, and schedule narrative to the District Scheduler and the Resident Construction Engineer. The schedule Adobe file shall include the following columns in 11 inch x 17 inch format: Activity ID, Activity Name, Start, Finish, Schedule % Complete, Physical % Complete, Budgeted Total Cost, Actual Total Cost, Remaining Total Cost, At Completion Total Cost, Original Duration, Remaining Duration, At Completion Duration, Earned Value, Planned Value, Schedule Variance Index, and Total Float. Sort on "Start" prior to printing to Adobe.

Schedule Narrative: Submit a Schedule Narrative Report with the baseline and each monthly update schedule describing current project schedule status and identifying potential delays. This report will include a description of the progress made since the previous schedule submission and objectives for the upcoming 30 calendar days.

- 1) Address all previous schedule review comments;

SUPPLEMENTAL SPECIFICATIONS

- 2) The report shall indicate if the project is *on schedule*, *ahead of schedule* or *behind schedule* as compared to the accepted baseline. Include the Schedule Variance Index, planned value cost and earned value cost. If the project is ahead of schedule or behind schedule, the report shall include the specific number of calendar days. If the project is behind schedule, the report shall include a detailed recovery plan that will put the project back on schedule. The narrative shall compare the Substantial Completion milestone for the baseline with the update;
- 3) Describe the *current critical path* of the project including the lowest total float value and indicate if this has changed in the last 30 calendar days. Discuss current successes or problems that have affected either the critical path's length or have caused a shift in the critical path within the last 30 calendar days. Identify specific activities, progress, or events that may reasonably be anticipated to impact the critical path within the next 30 calendar days, either to affect its length or to shift it to an alternate path;
- 4) List all schedule logic or duration changes that have been made to the schedule since the previous submission. Provide an explanation for any *constraint* used. For each change, describe the basis for the change and specifically identify the affected activities by identification number;
- 5) Scheduling assumptions (considerations for known and foreseeable constraints or restrictions such as weather, traffic, environmental, utility, safety, etc);
- 6) Identify activities, either in progress or scheduled to occur within the following 30 calendar days that require Department participation, review, approval, etc;
- 7) Identify any calendars used that are not DOT specific, and explain the details of those calendars;
- 8) Identify schedule settings used;
- 9) Identify activity expense item changes;
- 10) Minimized the use of lag. Where possible, use an activity to represent lag time. In no instance shall negative lag be used;
- 11) Description of how the schedule is organized (e.g. broken down by road or activity);
- 12) Explain any actual duration exceeding the original duration;
- 13) Explain out of sequence activities individually and the overall effect on the schedule;
- 14) Explain, individually, activities that failed to start in the previous 30 days;
- 15) Include the current contract completion date;
- 16) Include the current contract amount and sum of actual cost;
- 17) Include approved change orders. Explain the costs and schedule change associated with them;
- 18) Submit the narrative with a naming convention of [Contract ID]n[Data Date].doc (e.g 32.82571n060201.doc). Contractor will upload the electronic copy [in .doc format] to the South Carolina Department of Transportation Construction Extranet site;
- 19) Explain the schedule impacts of all utility work, known or anticipated;

Schedule Details

SCDOT reserves the user_text1 and user_text2 fields.

SUPPLEMENTAL SPECIFICATIONS

Data Date - The Baseline Construction Schedule shall have a data date equal to award date and not include any completed work to date. Monthly schedule updates shall have a data date set to one day beyond the most recent estimate period end date.

Milestones - Schedule shall identify the following milestones as a minimum:

- **Award Date:** The date the Contractor is notified by the Director of Construction that he is awarded the project.
- **Contract Execution Date:** The date the contract is signed by the Department.
- **Baseline CPM Acceptance:** *Anticipated date the baseline schedule is accepted. No work will start prior to this milestone date.*
- **Notice to Proceed Date (NTP):** the NTP date is determined in coordination between the Engineer and the Contractor.
- **Work Begin Date:** Actual date that on-site work commences. In the baseline CPM schedule, this is the anticipated work begin date by either the prime contractor or any subcontractor. Once work begins, status the schedule with the actual date recorded in SiteManager.
- **Interim Completion Dates or Interim Milestones:** When interim completion dates or interim milestones (associated with project stages) are included in the contract specifications.
- **Mobilization:** Preparations for and moving of equipment, etc., to the project site.
- **Start of Paving:** Date paving production and placement is to start. This includes any paving requiring a SCDOT certified inspector representing the Department.
- **Substantial Work Complete Date:** The point in the project when all pay items have been installed in reasonable conformance with the plans and specifications over the entire length of the project including tie-ins and all lanes of traffic are open to the public in their final configuration with the final applications of thermoplastic and raised pavement markers. The only remaining work to be performed is punch list items. Place a Finish On or Before constraint on this milestone equal to the completion date in the contract. If a change order is completed for time, update the constraint to the adjusted completion date.
- **As-Built CPM Schedule Submission:** The point in time in which the final schedule submission is made.
- **Project Liability Insurance Expiration Date MM/DD/YY:** This date references the expiration of the insurance as defined in Section 103.8 of the Standard Specification for Highway Construction. Include the date that the project liability insurance expires in the milestone activity name. If the expiration renewal date is prior to the Contract Completion Date, place a "Finish On" constraint on the finish milestone. If the expiration renewal date is beyond the Contract Completion Date, place an "As Late As Possible" constraint on the finish milestone. There are no logic ties for this milestone. Inclusion of this date in the CPM schedule does not relieve the contractor of his responsibility to retain liability insurance as defined by the Standard Specifications for Highway Construction.

Activities –

- Each Activity shall be part of the logic driven network, be cost loaded using Expense Categories, and include a predecessor (except the first activity) and a successor (except the last activity).
- Each Activity Name shall include a verb and a noun and represent the work function.
- Activity Names shall include the location of the work when there are multiple activities of the same work in different locations of the project.
- Limit activity original duration to 30 calendar days.

As a minimum, and when applicable, the schedule shall include the following activities when related work is part of the contract.

- **Mobilization:** Provide the same number of mobilization activities as for payment in the proposal i.e.
 - **Mobilization Payment I**
 - **Mobilization Payment II**
- **Clearing & Grubbing:** Self-explanatory.
- **Utility Relocations:** The schedule must reflect the utility relocations noted in the contract documents and include activities of appropriate duration for the utility adjustments. Where utility

SUPPLEMENTAL SPECIFICATIONS

durations are unknown, the Contractor shall provide a reasonable estimate of duration. Relate utility activities to the contract work activities that they effect or are affected by.

- **Cure Period:** The period of time between two activities needed for material curing. Examples include concrete and thermoplastic pavement markings. For this activity, use a seven day work week calendar.
 - **Earthwork:** Unclassified & borrow excavation, compaction, fine grading, etc.
- **Drainage:** Pipe, catch basins, manholes, etc.
- **Base Course:** Graded aggregate base courses, cement modified bases, etc.
- **Paving:** Hot mix asphalt base, intermediate, and surface courses; Portland cement concrete pavements, etc.
- **Structures:** Bridges, box culverts, retaining walls, etc.

Where sufficient detail has not been provided in included activities to determine progress of work and forecast of inspection and cost, the Department will request additional activities be added. The Department requires retain logic be used in scheduling projects. Relationship ties of all out-of-sequence activities should be corrected to reflect the actual occurrence. The use of progress override is not permitted. The monthly schedule update narrative shall justify any logic change(s).

Suspend Dates - The use of suspended dates is prohibited. If the activity is disrupted, break out into additional activities and explain in narrative.

Activity Expected Finish Dates – Activity Expected Finish dates are prohibited.

Resources – The Department will not require any input to the resource component of the schedule by the Contractor.

Expenses – Contractor shall assign the SCDOT contract items as expenses to each activity. The information provided under Expenses is used to evaluate daily production rates. SCDOT contract items will be included as Expense Categories and will be made part of the SCDOT schedule template available to download from the construction Extranet site. These shall be the only expense categories associated with activities. Under expenses, populate the fields Budgeted Units, Price/Unit, and Actual Units. If a SCDOT contract item cannot be found in the most current template, SCDOT should be contacted. The template will then be updated and uploaded to the extranet by SCDOT.

Weather - Considerations for normal weather shall be addressed within the activity duration.

Calendars – Contractor shall assign an appropriate SCDOT calendar to each activity in the schedule. Alternate calendars may be assigned, but specifics of the alternate calendars must be justified in the baseline narrative. Contractor shall assign all calendars as project specific – NOT GLOBAL. Acceptance of the alternate calendars is subject to review by the SCDOT. Considerations for weather shall be addressed within the activities – calendars shall not be modified to account for weather considerations. While calendars have been created to address established seasonal restrictions, it is the Contractor's responsibility to assure that all restrictions, as identified in the contract documents, are included. Where the Contractor elects to not utilize all available contract time in the baseline schedule submission, either by blocking out days in the calendar or including an activity for an extended period of no work, future delays against the time omitted will not warrant additional time.

The Baseline Construction Schedule shall not extend beyond the number of working days or contract completion date originally provided in the contract.

Cost Loading – All schedule activities shall be cost loaded using the contract bid items (Expense Categories), unit prices, and units (quantities) under "Expenses" in Primavera. Associated expenses shall correlate with the item of work covered by the activity.

Float – Float is not for the exclusive use or benefit of either the Department or the Contractor. Negative float in the original baseline schedule is not allowed.

Schedule Layout – Organize the schedule using a Work Breakdown Structure (WBS) consistent with the phasing and staging noted in the contract documents.

SUPPLEMENTAL SPECIFICATIONS

Default Values – Contractor shall use the following defaults, physical percent complete, retain logic, longest path critical activities, and under Admin Preferences, make Time Periods 8.0 hours/day, 40 hours/week, 172 hours/month, and 2,000 hours/year.

Submission, Review and Acceptance Process

Baseline Schedule –

Submission:

Regular Bid Projects:

Contractor shall submit a Critical Path Method (CPM) Contract Schedule and Narrative to the District Scheduler no more than 15 calendar days after execution of the contract or 15 days prior to the preconstruction conference, whichever is earlier. Once the initial baseline schedule is submitted, a preconstruction meeting date may be assigned by the RCE and Contractor. The CPM Schedule and Narrative shall be submitted via upload to the Extranet. Upon upload, the Contractor shall immediately notify the District Scheduler and the Resident Engineer via email that the CPM schedule has been submitted. The accepted CPM baseline schedule is paid for in the first available estimate period after contract execution.

A+B Bid Projects:

Contractor shall submit a Critical Path Method (CPM) Contract Schedule and Narrative to the District Scheduler no less than 15 calendar days prior to the preconstruction conference. Once the initial baseline schedule is submitted, a preconstruction meeting date can be assigned by the RCE and Contractor. The preconstruction meeting shall be assigned no earlier than 15 calendar days after the initial baseline submission. The CPM Schedule and Narrative shall be submitted via upload to the Extranet. Upon upload, the Contractor shall immediately notify the District Scheduler and the Resident Engineer via email that the CPM schedule has been submitted.

Review:

Upon receipt of the CPM Construction Schedule, SCDOT shall review and provide comments to the Contractor within 10 business days of receipt. The Contractor will have 5 business days to respond to SCDOT comments. This process will continue until the Engineer and the District Scheduler determines the construction schedule is acceptable.

The Contractor's representative familiar with the submitted schedule shall present and discuss their accepted schedule at the Preconstruction Conference. In the event the schedule has not been accepted (i.e. review process is ongoing), the most current schedule under review shall be presented.

Acceptance:

Acceptance of the submitted schedule by the SCDOT will establish the baseline schedule for the contract. This acceptance by SCDOT does not serve to excuse any omissions or errors in the Contractor's schedule (i.e. activities not included in baseline will not be considered in any time extensions).

Review and **acceptance of baseline schedule is required prior to start of work**. Delays in reaching this acceptance will not constitute a basis for granting additional contract time. If there is no concurrence or input from the utility provider concerning the Contractor's utility durations within 15 days following the Preconstruction Conference, the submission with the Contractor's estimate of utility duration will be reviewed for baseline acceptance. Further utility duration changes beyond this point in time will be assessed in monthly schedule updates.

Monthly Updates –

Monthly updates shall be made no later than 15 calendar days following the most recent estimate period end date, whether or not an estimate was generated and shall have a data date one day beyond the most recent estimate period end date. If no work was completed during the estimate period, an update with the most current estimate period is required. Upon upload, the Contractor shall immediately notify the District

SUPPLEMENTAL SPECIFICATIONS

Scheduler and the Resident Engineer via email that the CPM schedule has been submitted. Failure to submit timely updates will result in SCDOT evaluating contract status from the last submitted update schedule by adjusting the data date to the most current estimate period end date. Late update submittals may result in the Contractor being evaluated for preliminary delinquency in accordance with current version of the South Carolina Department of Transportation Standard Specifications for Highway Construction. Habitually late submittals may result in automatic delinquency. Failure to submit acceptable schedule updates as required will result in the withholding of the partial payment estimate regardless of preliminary delinquency. Updates shall include the following:

- Updated schedule to show actual progress on activities;
- Updated schedule to show actual costs on activities;
- Change orders that have occurred during the last estimate period;
- Any task dependent activity greater than 30 days in actual duration that has not incurred additional costs since the last update shall be terminated and broken into additional activities. Document the activity change and reason for late completion in the narrative;
- Remaining costs on completed activities are zeroed (if remaining costs are redistributed, indicate in the narrative the activities containing the costs);
- Update remaining cost appropriately;
- Updated schedule to show actual completion on milestones;
- Narrative to describe progress, planned activities, issues, adjustments to remedy any activities or milestones behind schedule, etc., in the format described in Schedule Submissions;
- Any changes other than those to actual start, actual finish, remaining duration, and Percent Complete are considered revisions. Revisions to a schedule update are subject to acceptance by the Engineer;

As-Built Schedule – A final As-Built Schedule shall be submitted within 15 calendar days following the contract completion. The as-built schedule should reflect the final project including extra work from change orders.

Baseline Schedule Changes – Once the baseline schedule has been accepted, all subsequent schedules provided will be considered schedule updates and compared to the original baseline. A new baseline will only be considered when significant changes in contract scope, changes in SCDOT priorities, or delays beyond the control of the Contractor occur.

If a baseline change is needed, the Contractor shall provide, in writing, a request to the Resident Construction Engineer with the following information:

- An electronic copy of the proposed baseline schedule using the following naming convention and in accordance with **Schedule Types** (included previously)

Type of Schedule Submitted:	Updated Baseline
File Name Convention:	[Contract ID]ub[Data Date]
File Name Example:	32.82571ub060201

- Narrative identifying changes warranting a new baseline

A decision for an updated baseline will be made jointly between the Resident Engineer and the District Scheduler within 10 business days of receipt of request.

Progress Meetings- The contractor shall present the most current schedule at progress meetings to discuss any issues and upcoming events. If found necessary by the SCDOT, the contractor shall attend meetings to specifically discuss issues about the schedule.

Level 3 Schedule Requirements

Level 3 schedule requirements will be enforced on contracts where the bid amount exceeds \$20 million and one of the following occurs:

SUPPLEMENTAL SPECIFICATIONS

- SCDOT financial status warrants the specific control of large project monthly payouts
- The contract SVI is less than -0.50 or greater than 0.50 for two consecutive months indicating the project is significantly behind or ahead of the Contractor’s baseline schedule.

In the event that the Department chooses to enforce the Level 3 Schedule Requirement, the Contractor will submit an updated baseline schedule within 15 days of notification. The Contractor schedule will be used for payment purposes once the baseline schedule has been accepted by the Department. In addition to meeting the requirements of the Level 2 Schedule, the following shall apply.

Once accepted by SCDOT, the project’s initial baseline cost loaded CPM will be used for SCDOT budget purposes and the contractor will not be paid in excess of the cumulative amount shown on the schedule through each payment date; regardless of what subsequent monthly updates indicate. For example, see chart below:

Pay period ending	12/31/11	1/31/12	2/29/12	3/31/12	4/30/12	5/31/12
Baseline CPM Planned Payout in Millions (Cumulative to Date)	2.0 (2.0)	3.0 (5.0)	3.0 (8.0)	4.0 (12.0)	4.0 (16.0)	3.0 (19.0)
Actual work performed (Cumulative to Date)	1.5 (1.5)	2.0 (3.5)	3.5 (7.0)	6.0 (13.0)	3.0 (16.0)	4.0 (20.0)
Payout by SCDOT (Cumulative to Date)	1.5 (1.5)	2.0 (3.5)	3.5 (7.0)	5.0 (12.0)	4.0 (16.0)	3.0 (19.0)

Partial payment estimates will be generated in SiteManager (computerized construction management system) based on actual quantities installed. If actual quantities installed exceed the cumulative schedule amount to date, a negative adjustment will be made in SiteManager to adjust the pay as necessary. For previous work exceeding the schedule amount, payments will be released as work progresses and payouts fall below the scheduled cumulative amount, never to exceed the cumulative scheduled amount through that pay period.

If significant contract changes are necessary, and upon approval by the SCDOT, a re-baseline to the initial CPM will be allowed per the CPM schedule specification and the payout schedule may be adjusted accordingly.

All subcontractors must be paid in accordance with the Prompt Payment Clause (Supplemental Specification dated June 14, 2000) for the quantities used to generate the partial payment estimates. In instances where a payout by SCDOT is less than the actual work installed under a given estimate, the Prompt Payment Clause is hereby amended to require full payment to all subcontractors, for work complete, within 7 days of receipt of said SCDOT payout.

Contract Schedule Performance Evaluation:

Project performance is not measured for contracts where the percent time < 0.30 for projects with a Level I Requirement and percent time < 0.20 for projects with the Level II Requirement or Level III Requirement.

$$\text{Percent Time} = (\text{Last Estimate Date} - \text{NTP}) / [(\text{Adj Completion Date}) - (\text{NTP})]$$

Level I Requirement: Contracts with a minimal schedule requirement that are not deemed “on-call.”

Performance curves were developed using historical data from SiteManager based on contract type and ranges of contract amount. For each of these groupings, three curves identifying minimal performance levels are used to measure project performance. On the example below, the curves indicate that projects falling below the 50th percentile line are slower than 50 percent of the projects of same type and in the range of the bid amount indicated. Projects falling below the 40th percentile line are slower than 60 percent of the projects of the same type and in the range of the bid amount indicated. Projects falling

SUPPLEMENTAL SPECIFICATIONS

below the 25th percentile line are slower than 75 percent of the projects of the same type and in the range of the bid amount indicated.

On a monthly basis at the end of the estimate period, a comparison of Time Percent Complete vs. Work Percent Complete will be made and plotted on a performance curve matching the contract type within the bid amount. The measurements are defined as:

$$\text{Time Percent Complete} = (\text{Last Estimate Date} - \text{NTP}) / [(\text{Adj Completion Date}) - (\text{NTP})]$$

$$\text{Work Percent Complete} = \text{Total Paid} / (\text{Total Bid} + \text{CO})$$

Poor Performance is considered when any contract is beyond its Adjusted Contract Completion date or when Time Percent Complete versus Work Percent Complete plots in the shaded area (on the appropriate performance curve) as defined by:

[30%, 75%) time below the 25th percentile line

-or-

[75%, 100%] time below the 40th percentile line.

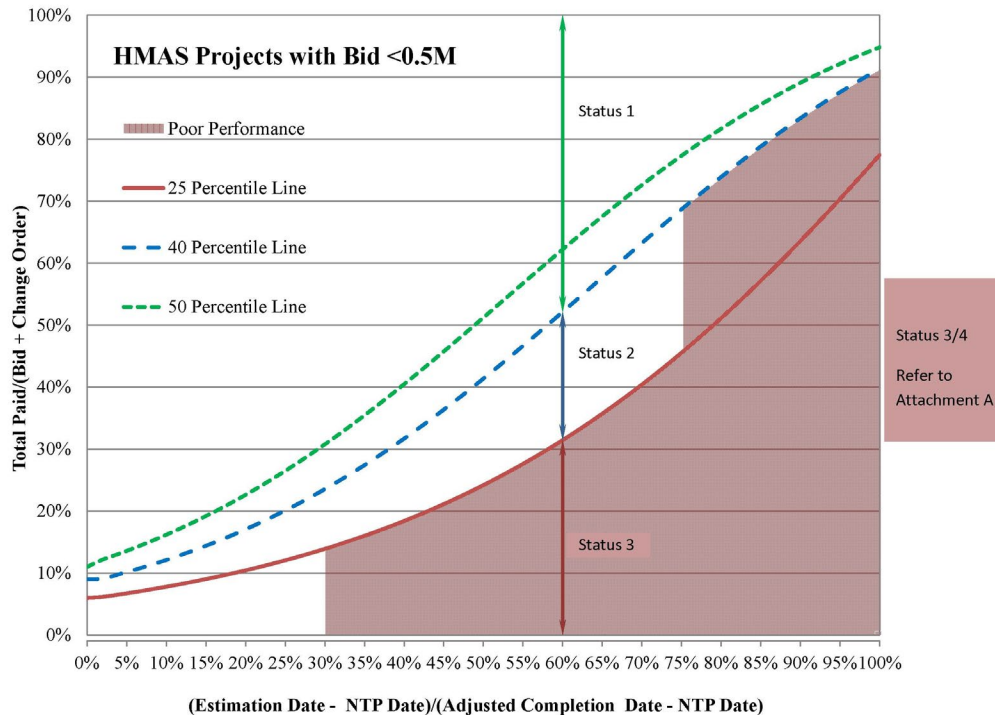

Example Performance Curve

Performance curves may be found under Construction Schedule Templates on the Extranet at:

<https://www.scdot.org/business/constructionletting-extranet.aspx>

Contracts with a CPM – Level II and III Schedule:

Monthly CPM updates are required for contracts with a CPM Level II or Level III schedule requirement as defined under **Submission, Review and Acceptance Process**. The contractor shall update actual completed quantities and physical percent complete (% of work complete for the activity) for all activities impacted during the most recent estimate period. Budgeted cost of the work performed (Earned Value) from the schedule update and budgeted cost of work planned (Planned Value) from the accepted

SUPPLEMENTAL SPECIFICATIONS

baseline schedule are used to determine project variance in Primavera utilizing Schedule Variance Index (SVI). The calculation used by Primavera is:

$$\text{Schedule Variance Index (SVI)} = (\text{Earned Value} - \text{Planned Value}) / \text{Planned Value}$$

Where $SVI < -0.10$, the contract is considered to be slipping behind plan.

Contract Performance Action:

A summary of progress performance action is included in Attachment A. Preliminary Notice of Delinquency is abbreviated as PND.

Level I Schedules:

When plotting Time Percent Complete vs Work Percent Complete as indicated above, if the contract falls in the shaded section on the appropriate performance curve,

First Offense:

- PND w/o bonding notification
- Request recovery plan

Second Offense:

- PND w/bonding notice
- Request recovery plan
- Hold PND to monitor recovery plan. If plan not met, move to delinquency

Level II or III Schedules:

In any estimate period where the SVI is $(-0.20, -1.0]$ as defined under: **Contracts with a CPM – Level II and III Schedule:**

First Offense:

- PND w/o bonding notification
- Request recovery plan

Second Offense:

- PND w/bonding notice
- Request recovery plan
- Hold PND to monitor recovery plan. If plan not met, move to delinquency

Measurement and Basis of Payment

Level 1 Schedule

There is no separate measurement or payment for look-ahead schedules. All costs associated with the preparation or revision of a look-ahead schedule are considered incidental to the work.

Level 2 and 3 Schedules

The Department will make partial payments according to Section 109, Standard Specifications for Highway Construction, and as modified by the following schedule:

Basis of Payment	Percentage of Contract Unit Price of Item
After the Engineer has accepted the CPM Baseline schedule	60
After the Engineer has accepted the As-Built CPM schedule	40

SUPPLEMENTAL SPECIFICATIONS

Type of Schedule	Ahead of Schedule	Status 1 Action	Status 2 Action	Status 3 Action	Status 3 Action	Status 3 Action	Status 4 Action
Level I Performance Curve	Projects falling above the 50% curve Monitor payouts	No Action	When plotting Time Percent Complete vs Work Percent Complete, if the contract falls in the shaded section of Status 2 or Status 3 on the appropriate performance curve, <u>First Offense:</u> -PND w/o bonding notification -Request recovery <u>Second Offense:</u> -PND w/bonding notice -Request recovery plan -Hold PND to monitor recover plan. If plan not met, move to delinquency.	Status 3 Complete Complete, if the contract falls in the shaded section of Status 2 or Status 3 on the appropriate performance curve, <u>First Offense:</u> -PND w/o bonding notification -Request recovery <u>Second Offense:</u> -PND w/bonding notice -Request recovery plan -Hold PND to monitor recover plan. If plan not met, move to delinquency.	If the contract has not reached substantial completion and is beyond contract completion < 45 days Preliminary Notice of Default w/bonding notice - Request plan to complete -Hold preliminary notice to monitor plan to complete. If plan not met, move to Default.	If has not reached substantial completion and contract is beyond the contract completion > 45 days, Notice of Default according to the Standard Specifications -Request plan to complete	
Level II or III CPM	SVI > 0.10 Monitor payouts	SVI > -0.10 No Action	SVI (-0.10, -0.25] Where SVI (-0.20, -1.0] <u>First Offense:</u> -PND w/o bonding notification -Request recovery <u>Second Offense:</u> -PND w/bonding notification -Request recovery plan -Hold PND to monitor recover plan. If plan not met, move to delinquency.	SVI (-0.25, -1.0]	If the contract is beyond contract completion < 45 days Preliminary Notice of Default w/bonding notice - Request plan to complete -Hold preliminary notice to monitor plan to complete. If plan not met, move to Default.	If contract is beyond the contract completion > 45 days, Notice of Default according to the Standard Specifications - Request plan to complete	
		Notes: [indicates inclusive of value (indicates exclusive of value					

Attachment A – Summary of Progress Performance Action

January 4, 2012

FINE GRADING

Fine Grading is the work necessary to bring the subgrade material into the final shape and compacted condition prescribed in the Contract documents. The area considered for Fine Grading is defined in **Section 208** of the 2007 SCDOT Standard Specifications.

To clarify the area for the item Fine Grading, modify the following subsections in **Section 208** as indicated below.

Subsection 208.4.3 Fine Grading

Delete the third paragraph and replace it with the following:

- 3 Fine Grading is defined as the work necessary to bring the subgrade material into the final shape and compacted condition prescribed in the Contract documents. The subgrade surface area paid for as Fine Grading is only the area under the permanent pavement structure plus 18 inch beyond the longitudinal edge of the permanent pavement structure. Except for the additional 18 inches beyond the permanent pavement structure, the area under existing pavement that remains in place, unpaved shoulders, driveways, curbs, gutters, sidewalks, multi-use paths, temporary pavement, and slopes is not included in the Fine Grading area.

Subsection 208.5 Measurement

Delete the first and second paragraphs and replace them with the following:

- 1 The quantity for the pay item Fine Grading is the surface area of the subgrade that is constructed and prepared for the intended pavement structure as defined in paragraph 3 of **Subsection 208.4.3** and is measured by the square yard (SY), complete, and accepted. The bid quantity will be considered the full amount to be paid unless work requiring fine grading is deleted, or additional work is added to the project that was not required by the original bid documents.
- 2 If the pay item Fine Grading is not included in the Contract, subgrade work is not measured for payment directly and is considered included in contract unit bid price of the various other items of work. When Fine Grading is included in the Contract, the subgrade work for areas under previously existing pavement, unpaved shoulders, driveways, curbs, gutters, sidewalks, temporary pavement, and slopes is not measured for payment directly and is considered included in contract unit bid price of the various other items of work.

July 1, 2019

TRAFFIC CONTROL

Delete Subsection 601.1.3 of the Standard Specifications in their entirety and replace them with the following:

601.1.3 Closure Restrictions

601.1.3.1 General Restrictions

- 1 The Department reserves the right to restrict the installation of lane closures, road closures, shoulder closures, ramp closures, pacing operations or any other operations that will impact the efficient flow of traffic or hinder normal traffic operations on the roads of the South Carolina state highway system during peak travel hours and/or days, holidays, holiday weekends, extended holiday periods, weekends, special events or any time traffic volumes are high. Lane closures on high volume highways during peak traffic periods or at any time traffic volumes exceed the numerical values determined to be acceptable by the Department are PROHIBITED. Lane closures on routes with high volume commuter traffic during peak traffic periods are PROHIBITED.
- 2 Special events are events generating excessive traffic as determined by the Department. Lane closures, road closures, shoulder closures, pacing operations or any other operations that would impact the efficient flow of traffic or hinder normal traffic operations during special events are PROHIBITED unless otherwise directed by the Engineer.
- 3 The Department reserves the right to suspend a lane closure, road closure, shoulder closure, pacing operation or any other operation if the RCE determines a delay or a resulting traffic backup is excessive. Observe and maintain all project specific time restrictions as specified by the Plans, the Specifications and the RCE. Install and remove lane closures, road closures, shoulder closures, pacing operations, or any other operation that would impact the efficient flow of traffic or hinder normal traffic operations within the time restrictions including all relative traffic control devices and signs. Coordinate work activities requiring lane closures, road closures, shoulder closures, pacing operations or any other operation in accordance with all restrictions.
- 4 Installation and maintenance of a lane closure is PROHIBITED when not actively engaged in work activities specific to the location of the lane closure unless otherwise specified and approved by the RCE. The length of the lane closure shall not exceed the length of roadway anticipated to be subjected to the proposed work activities within the work shift time frame or the maximum lane closure length specified within the contract unless otherwise specified and approved by the RCE. Also, a maximum lane closure length specified within a contract does not warrant installation of the specified lane closure length when the length of the lane closure necessary for conducting the work activity is less. The length and duration of each lane closure, within the contract specified parameters, shall require approval by the RCE prior to installation. The length and duration of each lane closure may be reduced by the RCE if the work zone impacts generated by a lane closure are deemed excessive or unnecessary.
- 5 The presence of temporary signs, portable sign supports, traffic control devices, trailer mounted equipment, truck mounted equipment, personnel, and vehicles relative to the installation or removal of a closure is PROHIBITED within the temporary clear zone during the prohibited hours.

601.1.3.2 Holiday Restrictions

- 1 The Department prohibits lane closures on interstate highways during holiday weekends and extended holiday periods as defined below unless otherwise directed by the Engineer. The Department's holiday lane closure restrictions for holidays that are observed on a Monday will include the weekend and are considered a holiday weekend unless otherwise established by these specifications. The Department defines the typical Monday holiday weekend as from 6:00 am of the Friday before the weekend until 6:00 a.m. of the Tuesday after the holiday. Lane closures, road closures, shoulder closures, pacing operations or any other operations that will impact the efficient flow of traffic or hinder normal traffic operations during these Monday holiday weekends as defined

SUPPLEMENTAL SPECIFICATIONS

above are PROHIBITED unless otherwise directed by the Engineer.

- 2 Easter and Thanksgiving holidays are varied and extended holiday periods of a holiday weekend. Easter holidays are defined as from 12:00 noon of the Thursday before Easter until 6:00 p.m. of the Monday after Easter. Thanksgiving holidays are defined as from 12:00 noon of the Wednesday before Thanksgiving Day until 6:00 a.m. of the Monday after Thanksgiving Day. Lane closures, road closures, shoulder closures, pacing operations, or any other operations that will impact the efficient flow of traffic or hinder normal traffic operations during the Easter and Thanksgiving holidays as defined above are PROHIBITED unless otherwise directed by the Engineer.
- 3 Consider Independence Day (4th of July) an extended holiday period. This extended holiday period will vary from year to year depending upon the day of the week the 4th of July occurs. See the table below. Lane closures, road closures, shoulder closures, pacing operations or any other operations that will impact the efficient flow of traffic or hinder normal traffic operations during the Independence Day holiday as defined below are PROHIBITED unless otherwise directed by the Engineer.

INDEPENDENCE DAY (4th OF JULY) HOLIDAY	
DAY OF WEEK	DURATION
MONDAY	6:00 AM FRIDAY, JULY 1 ST through 10:00 PM TUESDAY, JULY 5 TH
TUESDAY	6:00 AM MONDAY, JULY 3 RD through 10:00 PM WEDNESDAY JULY 5 TH
WEDNESDAY	6:00 AM TUESDAY, JULY 3 RD through 10:00 PM THURSDAY JULY 5 TH
THURSDAY	6:00 AM WEDNESDAY, JULY 3 RD through 10:00 PM FRIDAY JULY 5 TH
FRIDAY	6:00 AM THURSDAY, JULY 3 RD through 10:00 PM MONDAY JULY 7 TH
SATURDAY	6:00 AM THURSDAY, JULY 2 ND through 10:00 PM MONDAY JULY 6 TH
SUNDAY	6:00 AM FRIDAY, JULY 2 ND through 10:00 PM TUESDAY JULY 6 TH

- 4 Consider Christmas an extended holiday period. This extended holiday period will vary from year to year depending upon the day of the week Christmas Day occurs. See the table below. Lane closures, road closures, shoulder closures, pacing operations or any other operations that will impact the efficient flow of traffic or hinder normal traffic operations during the Christmas holiday as defined below are PROHIBITED unless otherwise directed by the Engineer.

CHRISTMAS HOLIDAY

SUPPLEMENTAL SPECIFICATIONS

DAY OF WEEK	DURATION
MONDAY	6:00 AM FRIDAY, DECEMBER 22 ND through 10:00 PM WEDNESDAY JANUARY 3 RD
TUESDAY	6:00 AM FRIDAY, DECEMBER 21 ST through 10:00 PM THURSDAY JANUARY 3 RD
WEDNESDAY	6:00 AM FRIDAY, DECEMBER 20 TH through 10:00 PM FRIDAY JANUARY 3 RD
THURSDAY	6:00 AM TUESDAY, DECEMBER 23 RD through 10:00 PM SUNDAY JANUARY 4 TH
FRIDAY	6:00 AM WEDNESDAY, DECEMBER 23 RD through 10:00 PM SUNDAY JANUARY 3 RD
SATURDAY	6:00 AM THURSDAY, DECEMBER 23 RD through 10:00 PM MONDAY JANUARY 3 RD
SUNDAY	6:00 AM FRIDAY, DECEMBER 23 RD through 10:00 PM TUESDAY JANUARY 3 RD

601.1.3.3 Waiver of Restrictions

1

Waiver or modification of these restrictions or the established hourly lane closure prohibition hours shall require approval from either the Deputy Secretary of Engineering, the Chief Engineer for Operations, or the Chief Engineer for Project Delivery. When requesting such a waiver or modification of these restrictions, submit the request to the RCE no less than 30 calendar days prior to the day in question. The Department reserves the right to approve, deny, and/or rescind waivers at its discretion. The Department reserves the right to suspend a lane closure, road closure, shoulder closure, pacing operation or any other operation if the RCE determines a delay or a resulting traffic backup is excessive.

January 1, 2020

SECTION 810: EROSION CONTROL MEASURES

In addition to the erosion control measures specified in the Plans, Standard Specifications, Supplemental Technical Specifications and the Special Provisions, the Contractor is advised that all land disturbing activities (clearing and grubbing, excavation, borrow and fill) are subject to the requirements set forth in the following permits and regulations:

- South Carolina Code of Regulations 63-380, Standard Plan for Erosion, Sediment, and Stormwater Runoff Control. The regulation can be found at the South Carolina Legislature website.
- Erosion and Sediment Reduction Act of 1983 (Title 48, Chapter 18 of the South Carolina Code of Laws of 1983, as amended). Section 70 of this code authorized the South Carolina Department of Health and Environmental Control (SCDHEC) to administer this regulation with respect to lands under the jurisdiction of the South Carolina Department of Transportation. The code can be found at the South Carolina Legislature website.
- National Pollutant Discharge Elimination System (NPDES) General Permit Number SCR160000, effective January 1, 2013 (or latest version): The Environmental Protection Agency, in accordance with the Federal Clean Water Act, has granted to the South Carolina Department of Health and Environmental Control (SCDHEC) the authority to administer the Federal NPDES permit program in the State of South Carolina. The permit may be viewed at the SCDOT website.

In accordance with the NPDES General Permit SCR160000 section 2.1.E: "The Prime Contractor hired by SCDOT for a project will become a Secondary Operator with SCDOT upon signing the awarded contract. The Secondary Operator must complete the agreement found in Appendix B of the SCDOT Contract, (Contractor Certification Form). The agreement is to be signed in accordance with the signatory requirements of §122.22 of the South Carolina Regulation 61-9. The agreement is to be maintained with the SWPPP.

By signing the Contract, the contractor accepts/understands the terms and conditions of the *Storm Water Pollution Prevention Plan (SWPPP)* as required by the NPDES General Permit SCR160000 and may be legally accountable to SCDHEC for compliance with the terms and conditions of the SWPPP. In addition the contractor is responsible for ensuring all subcontractors comply with the SWPPP and the permit requirements.

The SCDOT will complete and forward a *Notice of Intent (NOI)* to SCDHEC. If SCDHEC does not send a letter within 10 business days of receipt of the *NOI*, authorizing coverage, denying coverage, or advising that a review of the *SWPPP* will take place, coverage will be automatically granted.

At the pre-construction conference, with the contractor, the *SWPPP* will be explained and discussed so that the contractor is made aware of their responsibilities in the *SWPPP*.

Upon authorization of coverage, the *SWPPP* is to be fully implemented. The prompt installation of erosion control devices should be coordinated with construction activities to maintain compliance with the above regulations and NPDES General Permit.

Erosion and Sediment Control Inspections are to be conducted by a qualified individual (Certified Erosion Prevention and Sediment Control Inspectors (CEPSCI), P.E., or those as stated in the permit) by the Department at least every 7-calendar days. A representative of the Contractor is also encouraged to accompany the inspection. Correct deficiencies noted during these inspections within the assigned

SUPPLEMENTAL SPECIFICATIONS

priority period. If deficiencies are not corrected within this timeframe, the RCE can stop all work (except erosion and sediment control measures) until the deficiencies are corrected.

Give special attention to critical areas within the project limits (i.e., running streams, water bodies, wetlands, etc.). In these areas, the RCE may direct the Contractor to undertake immediate corrective action, but in no case allow these deficiencies to remain unresolved more than 48 hours for a priority 1 deficiency or 7 days for a priority 2 deficiency. This is in accordance with their assigned priority as identified during the Erosion and Sediment Control Inspection.

Failure to adequately comply with the provisions as detailed above or any other required erosion control measures can result in stoppage of all contract operations (except erosion and sediment control measures) until corrective action has been taken. Additional sanctions may be invoked by the SCDHEC in accordance with their authority.

Fines assessed on the Department by SCDHEC as the result of the Contractor's non-compliance or violation of said permit provisions will be paid by the Department and will subsequently be deducted from any monies due or that may become due to the Contractor. In case no monies are due or available, the fines incurred will be charged against the Contractor's Surety.

PROMPT PAYMENT CLAUSE

(1) Subject to the provisions on retainage provided in Paragraph (2) below, when a subcontractor has satisfactorily performed a work item of the subcontract, the Contractor must pay the subcontractor for the work item within seven (7) calendar days of the Contractor's receipt of payment from SCDOT. A subcontractor shall be considered to have "satisfactorily performed a work item of the subcontract" when the SCDOT pays the Contractor for that work item.

(2) The Contractor may withhold as retainage up to five (5%) percent of a subcontractor's payment until satisfactory completion of all work items of the subcontract. "Satisfactorily completion of all work items of the subcontract" shall mean when the SCDOT pays the Contractor for the last work item of the subcontract. The Contractor must release to the subcontractor any retainage withheld within seven (7) calendar days from the date the Contractor receives payment from SCDOT for the last work item of the subcontract.

(3) Prior to receiving payment of each monthly estimate, the Contractor shall certify to SCDOT that the construction estimate is complete and that all subcontractors have been paid for work covered by previous estimates.

(4) Failure to comply with any of the above provisions shall result in one or more of the following sanctions: (1) no further payments to the Contractor unless and until compliance is achieved; (2) the Contractor being placed in default; and/or (3) the Contractor being declared delinquent, such delinquency being subject to procedures and penalties provided in 108.08 of the Standard Specifications.

Appendix A

EDA Required Specification Documents

"General Decision Number: SC20230040 01/06/2023

Superseded General Decision Number: SC20220040

State: South Carolina

Construction Type: Highway

Counties: Allendale, Bamberg, Barnwell, Beaufort, Colleton, Georgetown, Hampton, Jasper, Newberry, Orangeburg and Williamsburg Counties in South Carolina.

DOES NOT INCLUDE SAVANNAH RIVER SITE IN ALLENDALE AND BARNWELL COUNTIES

HIGHWAY CONSTRUCTION PROJECTS (excluding tunnels, building structures in rest area projects & railroad construction; bascule, suspension & spandrel arch bridges designed for commercial navigation, bridges involving marine construction; and other major bridges).

Note: Contracts subject to the Davis-Bacon Act are generally required to pay at least the applicable minimum wage rate required under Executive Order 14026 or Executive Order 13658. Please note that these Executive Orders apply to covered contracts entered into by the federal government that are subject to the Davis-Bacon Act itself, but do not apply to contracts subject only to the Davis-Bacon Related Acts, including those set forth at 29 CFR 5.1(a)(2)-(60).

If the contract is entered into on or after January 30, 2022, or the contract is renewed or extended (e.g., an option is exercised) on or after January 30, 2022:	. Executive Order 14026 generally applies to the contract. . The contractor must pay all covered workers at least \$16.20 per hour (or the applicable wage rate listed on this wage determination, if it is higher) for all hours spent performing on the contract in 2023.
If the contract was awarded on or between January 1, 2015 and January 29, 2022, and the contract is not renewed or extended on or after January 30, 2022:	. Executive Order 13658 generally applies to the contract. . The contractor must pay all covered workers at least \$12.15 per hour (or the applicable wage rate listed on this wage determination, if it is higher) for all hours spent performing on that contract in 2023.

The applicable Executive Order minimum wage rate will be adjusted annually. If this contract is covered by one of the Executive Orders and a classification considered necessary for performance of work on the contract does not appear on this wage determination, the contractor must still submit a conformance request.

Additional information on contractor requirements and worker protections under the Executive Orders is available at <http://www.dol.gov/whd/govcontracts>.

Modification Number Publication Date
 0 01/06/2023

SUSC2011-038 09/15/2011

	Rates	Fringes
CARPENTER (Form Work Only).....	\$ 14.47	**
CEMENT MASON/CONCRETE FINISHER...	\$ 14.11	**
IRONWORKER, REINFORCING.....	\$ 15.64	**
LABORER		
Asphalt, Includes Asphalt Distributor, Raker, Shoverler, and Spreader.....		
	\$ 10.96	**
Colleton.....	\$ 10.16	**
Common or General		
Beaufort.....	\$ 10.15	**
Colleton.....	\$ 10.16	**
Georgetown, Hampton, Jasper.....	\$ 10.07	**
Newberry, Allendale, Bamberg, Barnwell.....	\$ 11.82	**
Orangeburg.....	\$ 12.63	**
Williamsburg.....	\$ 10.01	**
Luteman.....	\$ 11.71	**
Pipelayer.....	\$ 13.87	**
Traffic Control-Cone Setter		
Allendale, Bamber, Barnwell, Newberry, Orangeburg.....		
	\$ 12.98	**
Beaufort, Colleton, Georgetown, Hampton, Jasper, Williamsburg.....		
	\$ 12.84	**
Traffic Control-Flagger.....	\$ 11.68	**
POWER EQUIPMENT OPERATOR:		
Backhoe/Excavator/Trackhoe		
Allendale, Bamberg, Barnwell, Newberry, Orangeburg.....		
	\$ 17.56	
Beaufort.....	\$ 15.20	**
Colleton.....	\$ 17.78	
Georgetown, Hampton, Jasper, Williamsburg.....		
	\$ 17.23	
Bulldozer.....	\$ 20.12	
Crane.....	\$ 16.62	
Grader/Blade.....	\$ 16.62	
Loader (Front End).....	\$ 15.51	**
Mechanic.....	\$ 18.22	
Milling Machine.....	\$ 18.83	
Paver		
Allendale, Bamberg, Barnwell, Newberry, Orangeburg, Williamsburg...		
	\$ 15.01	**
Beaufort.....	\$ 14.96	**
Colleton, Georgetown,		

Hampton, Jasper.....\$ 13.67 **
 Roller.....\$ 12.76 **
 Screed.....\$ 13.01 **
 Tractor.....\$ 13.26 **

TRUCK DRIVER

Dump Truck.....\$ 12.00 **
 Lowboy Truck.....\$ 14.43 **
 Single Axle, Includes
 Pilot Car.....\$ 12.04 **
 Tractor Haul Truck.....\$ 16.25

 WELDERS - Receive rate prescribed for craft performing
 operation to which welding is incidental.

=====
 ** Workers in this classification may be entitled to a higher
 minimum wage under Executive Order 14026 (\$16.20) or 13658
 (\$12.15). Please see the Note at the top of the wage
 determination for more information.

Note: Executive Order (EO) 13706, Establishing Paid Sick Leave
 for Federal Contractors applies to all contracts subject to the
 Davis-Bacon Act for which the contract is awarded (and any
 solicitation was issued) on or after January 1, 2017. If this
 contract is covered by the EO, the contractor must provide
 employees with 1 hour of paid sick leave for every 30 hours
 they work, up to 56 hours of paid sick leave each year.
 Employees must be permitted to use paid sick leave for their
 own illness, injury or other health-related needs, including
 preventive care; to assist a family member (or person who is
 like family to the employee) who is ill, injured, or has other
 health-related needs, including preventive care; or for reasons
 resulting from, or to assist a family member (or person who is
 like family to the employee) who is a victim of, domestic
 violence, sexual assault, or stalking. Additional information
 on contractor requirements and worker protections under the EO
 is available at
<https://www.dol.gov/agencies/whd/government-contracts>.

Unlisted classifications needed for work not included within
 the scope of the classifications listed may be added after
 award only as provided in the labor standards contract clauses
 (29CFR 5.5 (a) (1) (ii)).

 The body of each wage determination lists the classification
 and wage rates that have been found to be prevailing for the
 cited type(s) of construction in the area covered by the wage
 determination. The classifications are listed in alphabetical
 order of ""identifiers"" that indicate whether the particular
 rate is a union rate (current union negotiated rate for local),
 a survey rate (weighted average rate) or a union average rate
 (weighted union average rate).

Union Rate Identifiers

A four letter classification abbreviation identifier enclosed
 in dotted lines beginning with characters other than ""SU"" or
 ""UAVG"" denotes that the union classification and rate were

prevailing for that classification in the survey. Example: PLUM0198-005 07/01/2014. PLUM is an abbreviation identifier of the union which prevailed in the survey for this classification, which in this example would be Plumbers. 0198 indicates the local union number or district council number where applicable, i.e., Plumbers Local 0198. The next number, 005 in the example, is an internal number used in processing the wage determination. 07/01/2014 is the effective date of the most current negotiated rate, which in this example is July 1, 2014.

Union prevailing wage rates are updated to reflect all rate changes in the collective bargaining agreement (CBA) governing this classification and rate.

Survey Rate Identifiers

Classifications listed under the ""SU"" identifier indicate that no one rate prevailed for this classification in the survey and the published rate is derived by computing a weighted average rate based on all the rates reported in the survey for that classification. As this weighted average rate includes all rates reported in the survey, it may include both union and non-union rates. Example: SULA2012-007 5/13/2014. SU indicates the rates are survey rates based on a weighted average calculation of rates and are not majority rates. LA indicates the State of Louisiana. 2012 is the year of survey on which these classifications and rates are based. The next number, 007 in the example, is an internal number used in producing the wage determination. 5/13/2014 indicates the survey completion date for the classifications and rates under that identifier.

Survey wage rates are not updated and remain in effect until a new survey is conducted.

Union Average Rate Identifiers

Classification(s) listed under the UAVG identifier indicate that no single majority rate prevailed for those classifications; however, 100% of the data reported for the classifications was union data. EXAMPLE: UAVG-OH-0010 08/29/2014. UAVG indicates that the rate is a weighted union average rate. OH indicates the state. The next number, 0010 in the example, is an internal number used in producing the wage determination. 08/29/2014 indicates the survey completion date for the classifications and rates under that identifier.

A UAVG rate will be updated once a year, usually in January of each year, to reflect a weighted average of the current negotiated/CBA rate of the union locals from which the rate is based.

WAGE DETERMINATION APPEALS PROCESS

1.) Has there been an initial decision in the matter? This can be:

- * an existing published wage determination
- * a survey underlying a wage determination
- * a Wage and Hour Division letter setting forth a position on a wage determination matter

* a conformance (additional classification and rate) ruling

On survey related matters, initial contact, including requests for summaries of surveys, should be with the Wage and Hour National Office because National Office has responsibility for the Davis-Bacon survey program. If the response from this initial contact is not satisfactory, then the process described in 2.) and 3.) should be followed.

With regard to any other matter not yet ripe for the formal process described here, initial contact should be with the Branch of Construction Wage Determinations. Write to:

Branch of Construction Wage Determinations
Wage and Hour Division
U.S. Department of Labor
200 Constitution Avenue, N.W.
Washington, DC 20210

2.) If the answer to the question in 1.) is yes, then an interested party (those affected by the action) can request review and reconsideration from the Wage and Hour Administrator (See 29 CFR Part 1.8 and 29 CFR Part 7). Write to:

Wage and Hour Administrator
U.S. Department of Labor
200 Constitution Avenue, N.W.
Washington, DC 20210

The request should be accompanied by a full statement of the interested party's position and by any information (wage payment data, project description, area practice material, etc.) that the requestor considers relevant to the issue.

3.) If the decision of the Administrator is not favorable, an interested party may appeal directly to the Administrative Review Board (formerly the Wage Appeals Board). Write to:

Administrative Review Board
U.S. Department of Labor
200 Constitution Avenue, N.W.
Washington, DC 20210

4.) All decisions by the Administrative Review Board are final.

=====

END OF GENERAL DECISIO"

CERTIFICATION REGARDING LOBBYING LOWER TIER COVERED TRANSACTIONS

Applicants should review the instructions for certification included in the regulations before completing this form. Signature on this form provides for compliance with certification requirements under 15 CFR Part 28, "New Restrictions on Lobbying."

LOBBYING

As required by Section 1352, Title 31 of the U.S. Code, and implemented at 15 CFR Part 28, for persons entering into a grant, cooperative agreement or contract over \$100,000 or a loan or loan guarantee over \$150,000 as defined at 15 CFR Part 28, Sections 28.105 and 28.110, the applicant certifies that to the best of his or her knowledge and belief, that:

(1) No Federal appropriated funds have been paid or will be paid, by or on behalf of the undersigned, to any person for influencing or attempting to influence an officer or employee of any agency, a Member of Congress in connection with the awarding of any Federal contract, the making of any Federal grant, the making of any Federal loan, the entering into of any cooperative agreement, and the extension, continuation, renewal, amendment, or modification of any Federal contract, grant, loan, or cooperative agreement.

(2) If any funds other than Federal appropriated funds have been paid or will be paid to any person for influencing or attempting to influence an officer or employee of any agency, a Member of Congress, an officer or employee of Congress, or an employee of a member of Congress in connection with this Federal contract, grant, loan, or cooperative agreement, the undersigned shall complete and submit Standard Form-LLL, "Disclosure Form to Report Lobbying," in accordance with its instructions.

(3) The undersigned shall require that the language of this certification be included in the award documents for all subawards at all tiers (including subcontracts, subgrants, and contracts under grants, loans, and cooperative agreements) and that all subrecipients shall certify and disclose accordingly.

This certification is a material representation of fact upon which reliance was placed when this transaction was made or entered into. Submission of this certification is a prerequisite for making or entering into this transaction imposed by section 1352, title 31, U.S. Code. Any person who fails to file the required certification shall be subject to a civil penalty of not less than \$10,000 and not more than \$100,000 for each such failure occurring on or before October 23, 1996, and of not less than \$11,000 and not more than \$110,000 for each such failure occurring after October 23, 1996.

Statement for Loan Guarantees and Loan Insurance

The undersigned states, to the best of his or her knowledge and belief, that:

In any funds have been paid or will be paid to any person for influencing or attempting to influence an officer or employee of any agency, a Member of Congress, an officer or employee of Congress, or an employee of a Member of Congress in connection with this commitment providing for the United States to insure or guarantee a loan, the undersigned shall complete and submit Standard Form-LLL, "Disclosure Form to Report Lobbying," in accordance with its instructions.

Submission of this statement is a prerequisite for making or entering into this transaction imposed by section 1352, title 31, U.S. Code. Any person who fails to file the required statement shall be subject to a civil penalty of not less than \$10,000 and not more than \$100,000 for each such failure occurring on or before October 23, 1996, and of not less than \$11,000 and not more than \$110,000 for each such failure occurring after October 23, 1996.

As the duly authorized representative of the applicant, I hereby certify that the applicant will comply with the above applicable certification.

NAME OF APPLICANT

AWARD NUMBER AND/OR PROJECT NAME

PRINTED NAME AND TITLE OF AUTHORIZED REPRESENTATIVE

SIGNATURE

DATE

**NOTICE OF REQUIREMENTS FOR AFFIRMATIVE ACTION
TO ENSURE EQUAL EMPLOYMENT OPPORTUNITY
(EXECUTIVE ORDER 11246 AND 41 CFR PART 60-4)**

The following Notice shall be included in, and shall be a part of all solicitations for offers and bids on all Federal and federally assisted construction contracts or subcontracts in excess of \$10,000.

The Offeror's or Bidder's attention is called to the "Equal Opportunity Clause" and the "Standard Federal Equal Employment Opportunity Construction Contract Specifications" set forth herein.

The goals and timetables for minority and female participation, expressed in percentage terms for the Contractor's aggregate workforce in each trade on all construction work in the covered area, are as follows:

Timetables	Goals for minority participation for each trade	Goals for female participation for each trade
	33 %	6.9%

These goals are applicable to all the Contractor's construction work (whether or not it is Federal or federally assisted) performed in the covered area. If the contractor performs construction work in a geographical area located outside of the covered area, it shall apply the goals established for such geographical area where the work is actually performed. With regard to this second area, the contractor also is subject to the goals for both its federally involved and non federally involved construction.

The Contractor's compliance with the Executive Order and the regulations in 41 CFR Part 60-4 shall be based on its implementation of the Equal Opportunity Clause, specific affirmative action obligations required by the specifications set forth in 41 CFR 60-4.3(a), and its efforts to meet the goals. The hours of minority and female employment and training must be substantially uniform throughout the length of the contract, and in each trade and the contractor shall make a good faith effort to employ minorities and women evenly on each of its projects. The transfer of minority or female employees or trainees from Contractor to Contractor or from project to project for the sole purpose of meeting the Contractor's goals shall be a violation of the contract, the Executive Order, and the regulations in 41 CFR Part 60-4. Compliance with the goals will be measured against the total work hours performed.

The Contractor shall provide written notification to the Director of the Office of Federal Contract Compliance Programs within 10 working days of award of any construction subcontract in excess of \$10,000 at any tier for construction work under the contract resulting from this solicitation. The notification shall list the name, address and telephone number of the subcontractor; employer identification number of the subcontractor; estimated dollar amount of the subcontract; estimated starting and completion dates of the subcontract; and the geographical area in which the subcontract is to be performed. As used in this Notice, and in the contract resulting from this solicitation, the "covered area" is:

State of South Carolina

County of Georgetown

City of Andrews

**U. S. DEPARTMENT OF COMMERCE
ECONOMIC DEVELOPMENT ADMINISTRATION**



**EDA CONTRACTING PROVISIONS
FOR CONSTRUCTION PROJECTS**

These EDA Contracting Provisions for Construction Projects (EDA Contracting Provisions) are intended for use by recipients receiving federal assistance from the U. S. Department of Commerce - Economic Development Administration (EDA). They contain provisions specific to EDA and other federal provisions not normally found in non-federal contract documents. The requirements contained herein must be incorporated into all construction contracts and subcontracts funded wholly or in part with federal assistance from EDA.

TABLE OF CONTENTS

1. Definitions
2. Applicability
3. Federally Required Contract Provisions
4. Required Provisions Deemed Inserted
5. Inspection by EDA Representatives
6. Examination and Retention of Contractor's Records
7. Construction Schedule and Periodic Estimates
8. Contractor's Title to Material
9. Inspection and Testing of Materials
10. "OR EQUAL" Clause
11. Patent Fees and Royalties
12. Claims for Extra Costs
13. Contractor's and Subcontractor's Insurance
14. Contract Security Bonds
15. Labor Standards - Davis-Bacon and Related Acts
16. Labor Standards - Contract Work Hours and Safety Standards Act
17. Equal Employment Opportunity
18. Contracting with Small, Minority and Women's Businesses
19. Health, Safety and Accident Prevention
20. Conflict of Interest and Other Prohibited Interests
21. New Restrictions on Lobbying
22. Historical and Archaeological Data Preservation
23. Clean Air and Water
24. Use of Lead-Based Paints on Residential Structures
25. Energy Efficiency
26. Environmental Requirements
27. Debarment, Suspension, Ineligibility and Voluntary Exclusions
28. EDA Project Sign
29. Buy America

1. **DEFINITIONS**

Agreement – The written instrument that is evidence of the agreement between the Owner and the Contractor overseeing the Work.

Architect/Engineer - The person or other entity engaged by the Recipient to perform architectural, engineering, design, and other services related to the work as provided for in the contract.

Contract – The entire and integrated written agreement between the Owner and the Contractor concerning the Work. The Contract supersedes prior negotiations, representations, or agreements, whether written or oral.

Contract Documents – Those items so designated in the Agreement. Only printed or hard copies of the items listed in the Agreement are Contract Documents.

Contractor – The individual or entity with whom the Owner has entered into the Agreement.

Drawings or Plans – That part of the Contract Documents prepared or approved by the Architect/Engineer that graphically shows the scope, extent, and character of the Work to be performed by the Contractor.

EDA - The United States of America acting through the Economic Development Administration of the U.S. Department of Commerce or any other person designated to act on its behalf. EDA has agreed to provide financial assistance to the Owner, which includes assistance in financing the Work to be performed under this Contract. Notwithstanding EDA's role, nothing in this Contract shall be construed to create any contractual relationship between the Contractor and EDA.

Owner – The individual or entity with whom the Contractor has entered into the Agreement and for whom the Work is to be performed.

Project – The total construction of which the Work to be performed under the Contract Documents may be the whole, or a part.

Recipient – A non-Federal entity receiving a Federal financial assistance award directly from EDA to carry out an activity under an EDA program, including any EDA-approved successor to the entity.

Specifications – That part of the Contract Documents consisting of written requirements for materials, equipment, systems, standards, and workmanship as applied to the Work, and certain administrative requirements and procedural matters applicable thereto.

Subcontractor – An individual or entity having direct contract with the Contractor or with any other Subcontractor for the performance of a part of the Work at the Site.

Work – The entire construction or the various separately identifiable parts thereof required to be provided under the Contract Documents. Work includes and is the result of performing or providing all labor, services, and documentation necessary to produce such construction and furnishing, installing, and incorporating all materials and equipment into such construction, all as required by the Contract Documents.

2. **APPLICABILITY**

The Project to which the construction work covered by this Contract pertains is being assisted by the United States of America through federal assistance provided by the U.S. Department of Commerce - Economic Development Administration (EDA). Neither EDA, nor any of its departments, entities, or employees is a party to this Contract. The following EDA Contracting Provisions are included in this Contract and all subcontracts or related instruments pursuant to the provisions applicable to such federal assistance from EDA.

3. **FEDERALLY REQUIRED CONTRACT PROVISIONS**

(a) All contracts in excess of the simplified acquisition threshold - currently fixed at \$150,000 (*see* 41 U.S.C. §§ 134 and 1908) must address administrative, contractual, or legal remedies in instances where contractors violate or breach contract terms, and provide for such sanctions and penalties as may be appropriate.

(b) All contracts in excess of \$10,000 must address termination for cause and for convenience by the Recipient including the manner by which it will be effected and the basis for settlement.

(c) All construction contracts awarded in excess of \$10,000 by recipients of federal assistance and their contractors or subcontractors shall contain a provision requiring compliance with Executive Order 11246 of September 24, 1965, *Equal Employment Opportunity*, as amended by Executive Order 11375 of October 13, 1967, and Department of Labor implementing regulations at 41 C.F.R. part 60.

(d) All prime construction contracts in excess of \$2,000 awarded by Recipients must include a provision for compliance with the Davis-Bacon Act (40 U.S.C. §§ 3141-3148) as supplemented by Department of Labor regulations at 29 C.F.R. part 5. The contracts must also include a provision for compliance with the Copeland "Anti-Kickback" Act (18 U.S.C. § 874 and 40 U.S.C. § 3145) as supplemented by Department of Labor regulations at 29 C.F.R. part 3.

(e) All contracts awarded by the Recipient in excess of \$100,000 that involve the employment of mechanics or laborers must include a provision for compliance with 40 U.S.C. §§ 3702 and 3704 (the Contract Work Hours and Safety Standards Act) as supplemented by Department of Labor regulations at 29 C.F.R. part 5.

(f) All contracts must include EDA requirements and regulations that involve a requirement on the contractor or sub-contractor to report information to EDA, the Recipient or any other federal agency.

- (g) All contracts must include EDA requirements and regulations pertaining to patent rights with respect to any discovery or invention which arises or is developed in the course of or under such contract.
- (h) All contracts must include EDA requirements and regulations pertaining to copyrights and rights in data.
- (i) All contracts and subgrants in excess of \$150,000 must contain a provision that requires compliance with all applicable standards, orders, or requirements issued under the Clean Air Act (42 U.S.C. § 7401 *et seq.*) and the Federal Water Pollution Control Act (Clean Water Act) (33 U.S.C. § 1251 *et seq.*), and Executive Order 11738, *Providing for Administration of the Clean Air Act and the Federal Water Pollution Control Act With Respect to Federal Contracts, Grants, or Loans*.
- (j) Contracts must contain mandatory standards and policies relating to energy efficiency which are contained in the state energy conservation plan issued in compliance with the Energy Policy and Conservation Act (42 U.S.C. § 6201).
- (k) Contracts must contain a provision ensuring that contracts are not to be made to parties on the government wide Excluded Parties List System in the System for Award Management (SAM), in accordance with the OMB guidelines at 2 C.F.R. part 180.
- (l) Contracts must contain a provision ensure compliance with the Byrd Anti-Lobbying Amendment (31 U.S.C. § 1352) under which contractors that apply or bid for an award of \$100,000 or more must file the required certification. Each tier certifies to the tier above that it will not and has not used Federal appropriated funds to pay any person or organization for influencing or attempting to influence an officer or employee of any agency, a member of Congress, officer or employee of Congress, or an employee of a member of Congress in connection with obtaining any Federal contract, grant or any other award covered by 31 U.S.C. § 1352. Each tier must also disclose any lobbying with non-Federal funds that takes place in connection with obtaining any Federal award. Such disclosures are forwarded from tier to tier up to the non-Federal award.
- (m) If the Recipient is a state agency or agency of a political subdivision of a state, any contract awarded must contain a provision ensuring compliance with section 6002 of the Solid Waste Disposal Act (42 U.S.C. § 6962), as amended by the Resource Conservation and Recovery Act related to the procurement of recovered materials.

4. **REQUIRED PROVISIONS DEEMED INSERTED**

Each and every provision of law and clause required by law to be inserted in this contract shall be deemed to be inserted herein and the contract shall be read and enforced as though it were included herein, and if through mistake or otherwise any such provision is not inserted, or is not correctly inserted, then upon the application of either party the contract shall forthwith be physically amended to make such insertion of correction.

5. **INSPECTION BY EDA REPRESENTATIVES**

The authorized representatives and agents of EDA shall be permitted to inspect all work, materials, payrolls, personnel records, invoices of materials, and other relevant data and records.

6. **EXAMINATION AND RETENTION OF CONTRACTOR'S RECORDS**

(a) The Owner, EDA, or the Comptroller General of the United States, or any of their duly authorized representatives shall, generally until three years after final payment under this contract, have access to and the right to examine any of the Contractor's directly pertinent books, documents, papers, or other records involving transactions related to this contract for the purpose of making audit, examination, excerpts, and transcriptions.

(b) The Contractor agrees to include in first-tier subcontracts under this contract a clause substantially the same as paragraph (a) above. "Subcontract," as used in this clause, excludes purchase orders that do not exceed \$10,000.

(c) The periods of access and examination in paragraphs (a) and (b) above for records relating to (1) appeals under the disputes clause of this contract, (2) litigation or settlement of claims arising from the performance of this contract, or (3) costs and expenses of this contract to which the Owner, EDA, or Comptroller General or any of their duly authorized representatives has taken exception shall continue until disposition of such appeals, litigation, claims, or exceptions.

7. **CONSTRUCTION SCHEDULE AND PERIODIC ESTIMATES**

Immediately after execution and delivery of the contract, and before the first partial payment is made, the Contractor shall deliver to the Owner an estimated construction progress schedule in a form satisfactory to the Owner, showing the proposed dates of commencement and completion of each of the various subdivisions of work required under the Contract Documents and the anticipated amount of each monthly payment that will become due to the Contractor in accordance with the progress schedule. The Contractor also shall furnish the Owner (a) a detailed estimate giving a complete breakdown of the contract price and (b) periodic itemized estimates of work done for the purpose of making partial payments thereon. The costs employed in making up any of these schedules will be used only to determine the basis of partial payments and will not be considered as fixing a basis for additions to or deductions from the contract price.

8. **CONTRACTOR'S TITLE TO MATERIAL**

No materials, supplies, or equipment for the work shall be purchased by the Contractor or by any subcontractor that is subject to any chattel mortgage or under a conditional sale contract or other agreement by which an interest is retained by the seller. The Contractor warrants and guarantees that he/she has good title to all work, materials, and equipment used by him/her in the Work, free and clear of all liens, claims, or encumbrances.

9. **INSPECTION AND TESTING OF MATERIALS**

All materials and equipment used in the completion of the Work shall be subject to adequate inspection and testing in accordance with accepted standards. The laboratory or inspection agency shall be selected by the Owner. Materials of construction, particularly those upon which the strength and durability of any structure may depend, shall be subject to inspection and testing to establish conformance with specifications and suitability for intended uses.

10. **"OR EQUAL" CLAUSE**

Whenever a material, article, or piece of equipment is identified in the Contract Documents by reference to manufacturers' or vendors' names, trade names, catalogue numbers, etc., it is intended merely to establish a standard. Any material, article, or equipment of other manufacturers and vendors that will perform adequately the duties imposed by the general design will be considered equally acceptable provided the material, article, or equipment so proposed is, in the opinion of the Architect/Engineer, of equal substance and function. However, such substitution material, article, or equipment shall not be purchased or installed by the Contractor without the Architect/Engineer's written approval.

11. **PATENT FEES AND ROYALTIES**

(a) Contractor shall pay all license fees and royalties and assume all costs incident to the use in the performance of the Work or the incorporation in the Work of any invention, design, process, product, or device that is the subject of patent rights or copyrights held by others. If a particular invention, design, process, product, or device is specified in the Contract Documents for use in the performance of the Work and if, to the actual knowledge of Owner or Architect/Engineer, its use is subject to patent rights or copyrights calling for the payment of any license fee or royalty to others, the existence of such rights shall be disclosed by the Owner in the Contract Documents.

(b) To the fullest extent permitted by Laws and Regulations, the Contractor shall indemnify and hold harmless the Owner and the Architect/Engineer, and the officers, directors, partners, employees, agents, consultants, and subcontractors of each and any of them from and against all claims, costs, losses, and damages (including but not limited to all fees and charges of engineers, architects, attorneys, and other professionals and all court or arbitration or other dispute resolution costs) arising out of or relating to any infringement of patent rights or copyrights incident to the use in the performance of the Work or resulting from the incorporation in the Work of any invention, design, process, product, or device not specified in the Contract Documents.

12. **CLAIMS FOR EXTRA COSTS**

No claims for extra work or cost shall be allowed unless the same was done in pursuance of a written order from the Architect/Engineer approved by the Owner.

13. **CONTRACTORS AND SUBCONTRACTORS INSURANCE**

(a) The Contractor shall not commence work under this Contract until the Contractor has obtained all insurance reasonably required by the Owner, nor shall the Contractor allow any subcontractor to commence work on his/her subcontract until the insurance required of the subcontractor has been so obtained and approved.

(b) Types of insurance normally required are:

- (1) Workers' Compensation
- (2) Contractor's Public Liability and Property Damage
- (3) Contractor's Vehicle Liability
- (4) Subcontractors' Public Liability, Property Damage and Vehicle Liability
- (5) Builder's Risk (Fire and Extended Coverage)

(c) **Scope of Insurance and Special Hazards:** The insurance obtained, which is described above, shall provide adequate protection for the Contractor and his/her subcontractors, respectively, against damage claims that may arise from operations under this contract, whether such operations be by the insured or by anyone directly or indirectly employed by him/her and also against any of the special hazards that may be encountered in the performance of this Contract.

(d) **Proof of Carriage of Insurance:** The Contractor shall furnish the Owner with certificates showing the type, amount, class of operations covered, effective dates, and dates of expiration of applicable insurance policies.

14. **CONTRACT SECURITY BONDS**

(a) If the amount of this Contract exceeds \$150,000, the Contractor shall furnish a performance bond in an amount at least equal to one hundred percent (100%) of the Contract price as security for the faithful performance of this Contract and also a payment bond in an amount equal to one hundred percent (100%) of the Contract price or in a penal sum not less than that prescribed by State, Territorial, or local law, as security for the payment of all persons performing labor on the Work under this Contract and furnishing materials in connection with this Contract. The performance bond and the payment bond may be in one or in separate instruments in accordance with local law. Before final acceptance, each bond must be approved by EDA. If the amount of this Contract does not exceed \$150,000, the Owner shall specify the amount of the payment and performance bonds.

(b) All bonds shall be in the form prescribed by the Contract Documents except as otherwise provided in applicable laws or regulations, and shall be executed by such sureties as are named in the current list of *Companies Holding Certificates of Authority as Acceptable Sureties on Federal Bonds and as Acceptable Reinsuring Companies* as published in Treasury Circular 570 (amended) by the Financial Management Service, Surety Bond Branch, U.S. Department of the Treasury. All bonds signed by an agent must be accompanied by a certified copy of the agent's

authority to act. Surety companies executing the bonds must also be authorized to transact business in the state where the Work is located.

15. **LABOR STANDARDS - DAVIS-BACON AND RELATED ACTS**
(as required by section 602 of PWEDA)

(a) **Minimum Wages**

(1) All laborers and mechanics employed or working upon the site of the Work in the construction or development of the Project will be paid unconditionally and not less often than once a week, and without subsequent deduction or rebate on any account (except such payroll deductions as are permitted by regulations issued by the Secretary of Labor under the Copeland Act at 29 C.F.R. part 3, the full amount of wages and bona fide fringe benefits (or cash equivalents thereof) due at the time of payment computed at rates not less than those contained in the wage determination of the Secretary of Labor, which is attached hereto and made a part hereof, regardless of any contractual relationship that may be alleged to exist between the Contractor and such laborers and mechanics. Contributions made or costs reasonably anticipated for bona fide fringe benefits under Section 1(b)(2) of the Davis-Bacon Act on behalf of laborers or mechanics are considered wages paid to such laborers or mechanics, subject to the provisions of 29 C.F.R. § 5.5(a)(1)(iv); also, regular contributions made or costs incurred for more than a weekly period (but not less often than quarterly) under plans, funds, or programs, which cover the particular weekly period, are deemed to be constructively made or incurred during such weekly period. Such laborers and mechanics shall be paid the appropriate wage rate and fringe benefits on the wage determination for the classification of work actually performed, without regard to skill, except as provided in 29 C.F.R. § 5.5(a)(4). Laborers or mechanics performing work in more than one classification may be compensated at the rate specified for each classification for the time actually worked therein, provided that the employer's payroll records accurately set forth the time spent in each classification in which work is performed. The wage determination (including any additional classification and wage rates determined under 29 C.F.R. § 5.5(a)(1)(ii) and the Davis-Bacon poster (WH-1321) shall be posted at all times by the contractor and its subcontractors at the site of the work in a prominent and accessible place where it can be easily seen by the workers.

(2) (i) Any class of laborers or mechanics to be employed under the Contract, but not listed in the wage determination, shall be classified in conformance with the wage determination. EDA shall approve an additional classification and wage rate and fringe benefits therefore only when the following criteria have been met:

(A) The work to be performed by the classification requested is not performed by a classification in the wage determination;

(B) The classification is utilized in the area by the construction industry; and

(C) The proposed wage rate, including any bona fide fringe benefits, bears a

reasonable relationship to the wage rates contained in the wage determination.

(ii) If the Contractor and the laborers and mechanics to be employed in the classification (if known), or their representatives, and EDA or its designee agree on the classification and wage rate (including the amount designated for fringe benefits where appropriate), a report of the action taken shall be sent by EDA or its designee to the Administrator of the Wage and Hour Division, Employment Standards Administration, U.S. Department of Labor, Washington, D.C. 20210.

(iii) In the event the Contractor, the laborers or mechanics to be employed in the classification or their representatives, and EDA or its designee do not agree on the proposed classification and wage rate (including the amount designated for fringe benefits, where appropriate), EDA or its designee shall refer the questions, including the views of all interested parties and the recommendation of EDA or its designee, to the Administrator for determination.

(iv) The wage rate (including fringe benefits where appropriate) determined pursuant to paragraphs (a)(2)(ii) or (iii) of this section, shall be paid to all workers performing work in the classification under this contract from the first day on which work is performed in the classification.

(3) Whenever the minimum wage rate prescribed in the contract for a class of laborers or mechanics includes a fringe benefit which is not expressed as an hourly rate, the Contractor shall either pay the benefit as stated in the wage determination or shall pay another bona fide fringe benefit or an hourly cash equivalent thereof.

(4) If the Contractor does not make payments to a trustee or other third person, the Contractor may consider as part of the wages of any laborer or mechanic the amount of any costs reasonably anticipated in providing bona fide fringe benefits under a plan or program, provided, that the Secretary of Labor has found, upon the written request of the Contractor, that the applicable standards of the Davis-Bacon Act have been met. The Secretary of Labor may require the Contractor to set aside in a separate account assets for the meeting of obligations under the plan or program.

(b) **Withholding**

EDA or its designee shall upon its own action or upon written request of an authorized representative of the Department of Labor withhold or cause to be withheld from the Contractor under this Contract or any other federal contract with the same prime Contractor, or any other federally-assisted contract subject to Davis-Bacon prevailing wage requirements, which is held by the same prime contractor so much of the accrued payments or advances as may be considered necessary to pay laborers and mechanics, including apprentices, trainees and helpers, employed by the Contractor or any subcontractor the full amount of wages required by the Contract. In the event of failure to pay any laborer or mechanic, including any apprentice, trainee or helper employed or working on the site of the Work in the construction or development of the Project, all or part of the wages required by the Contract, EDA or its designee may, after written notice to the Contractor, sponsor, applicant, or owner, take such action as may be necessary to cause the suspension of any further payment, advance, or guarantee of funds until such violations

have ceased. EDA or its designee may, after written notice to the Contractor, disburse such amounts withheld for and on account of the Contractor or subcontractor to the respective employees to whom they are due. The Comptroller General shall make such disbursements in the case of direct Davis-Bacon Act contracts.

(c) **Payrolls and basic records**

(1) Payrolls and basic records relating thereto shall be maintained by the Contractor during the course of the Work and preserved for a period of three years thereafter for all laborers and mechanics working at the site of the Work in the construction or development of the Project. Such records shall contain the name, address, and social security number of each such worker, his or her correct classification, hourly rates of wages paid (including rates of contributions or costs anticipated for bona fide fringe benefits or cash equivalents thereof of the types described in section 1(b)(2)(B) of the Davis-Bacon Act), daily and weekly number of hours worked, deductions made and actual wages paid. Whenever the Secretary of Labor has found under 29 C.F.R. § 5.5(a)(1)(iv) that the wages of any laborer or mechanic include the amount of any costs reasonably anticipated in providing benefits under a plan or program described in section 1(b)(2)(B) of the Davis-Bacon Act, the Contractor shall maintain records which show that the commitment to provide such benefits is enforceable, the plan or program is financially responsible, and the plan or program has been communicated in writing to the laborers or mechanics affected, and provide records that show the costs anticipated or the actual cost incurred in providing such benefits. Contractors employing apprentices or trainees under approved programs shall maintain written evidence of the registration of apprenticeship programs and certification of trainee programs, the registration of the apprentices and trainees, and the ratios and wage rates prescribed in the applicable programs.

(2) (i) For each week in which Contract work is performed, the Contractor shall submit a copy of all payrolls to the Owner for transmission to EDA or its designee. The payrolls submitted shall set out accurately and completely all of the information required to be maintained under 29 C.F.R. part 5.5(a)(3)(i). This information may be submitted in any form desired. Optional Form WH-347 is available for this purpose. It may be purchased from the Superintendent of Documents (Federal Stock Number 029-005-00014-1), U.S. Government Printing Office, Washington, D.C. 20402; or downloaded from the U.S. Department of Labor's website at <https://www.dol.gov/whd/forms/wh347.pdf>. The prime Contractor is responsible for the submission of copies of payrolls by all subcontractors

(ii) Each payroll submitted shall be accompanied by a "Statement of Compliance," signed by the Contractor or subcontractor or his or her agent who pays or supervises the payment of the persons employed under the Contract and shall certify the following:

(A) That the payroll for the payroll period contains the information required to be maintained under 29 C.F.R. § 5.5(a)(3)(i) and that such information is correct and complete;

(B) That each laborer or mechanic (including each helper, apprentice, and trainee) employed on the Contract during the payroll period has been paid the full weekly wages earned, without rebate, either directly or indirectly, and that no deductions have been made either directly or indirectly from the full wages earned, other than permissible deductions as set forth in 29 C.F.R. part 3; and

(C) That each laborer or mechanic has been paid not less than the applicable wage rates and fringe benefits or cash equivalents for the classification of work performed, as specified in the applicable wage determination incorporated into the Contract.

(iii) The weekly submission of a properly executed certification set forth on the reverse side of Optional Form WH-347 shall satisfy the requirement for submission of the "Statement of Compliance" required by paragraph 15(c)(2)(ii) of this section.

(iv) The falsification of any of the above certifications may subject the Contractor or subcontractor to civil or criminal prosecution under section 1001 of Title 18 and section 3729 of Title 31 of the U.S. Code.

(3) The Contractor or subcontractor shall make the records required under paragraph 15(c)(1) of this section available for inspection, copying, or transcription by authorized representatives of EDA or its designee or the Department of Labor, and shall permit such representatives to interview employees during working hours on the job. If the Contractor or subcontractor fails to submit the required records or to make them available, EDA or its designee may, after written notice to the Contractor or Owner, take such action as may be necessary to cause the suspension of any further payment, advance, or guarantee of funds. Furthermore, failure to submit the required records upon request or to make such records available may be grounds for debarment action pursuant to 29 C.F.R. § 5.12.

(d) **Apprentices and Trainees.**

(1) **Apprentices.** Apprentices will be permitted to work at less than the predetermined rate for the work they performed when they are employed pursuant to and individually registered in a bona fide apprenticeship program registered with the U.S. Department of Labor, Employment and Training Administration, Bureau of Apprenticeship and Training (Bureau), or with a State Apprenticeship Agency recognized by the Bureau, or if a person is employed in his or her first 90 days of probationary employment as an apprentice in such an apprenticeship program, who is not individually registered in the program, but who has been certified by the Bureau of Apprenticeship and Training or a State Apprenticeship Agency (where appropriate) to be eligible for probationary employment as an apprentice. The allowable ratio of apprentices to journeymen on the job site in any craft classification shall not be greater than the ratio permitted to the Contractor as to the entire work force under the registered program. Any worker listed on a payroll at an apprentice wage rate who is not registered or otherwise employed as stated above, shall be paid not less than the applicable wage rate on the wage determination for the classification of work actually performed. In addition, any

apprentice performing work on the job site in excess of the ratio permitted under the registered program shall be paid not less than the applicable wage rate on the wage determination for the work actually performed. Where a Contractor is performing construction on a Project in a locality other than that in which its program is registered, the ratios and wage rates (expressed in percentages of the journeyman's hourly rate) specified in the Contractor's or subcontractor's registered program shall be observed. Every apprentice must be paid at not less than the rate specified in the registered program for the apprentice's level of progress, expressed as a percentage of the journeymen hourly rate specified in the applicable wage determination. Apprentices shall be paid fringe benefits in accordance with the provisions of the apprenticeship program. If the apprenticeship program does not specify fringe benefits, apprentices must be paid the full amount of fringe benefits listed on the wage determination for the applicable classification. If the Administrator determines that a different practice prevails for the applicable apprentice classification, fringes shall be paid in accordance with that determination. In the event the Bureau of Apprenticeship and Training, or a State Apprenticeship Agency recognized by the Bureau, withdraws approval of an apprenticeship program, the Contractor will no longer be permitted to utilize apprentices at less than the applicable predetermined rate for the work performed until an acceptable program is approved.

(2) **Trainees.** Except as provided in 29 C.F.R. § 5.16, trainees will not be permitted to work at less than the predetermined rate for the work performed unless they are employed pursuant to and individually registered in a program that has received prior approval, evidenced by formal certification by the U.S. Department of Labor, Employment and Training Administration. The ratio of trainees to journeymen on the job site shall not be greater than permitted under the plan approved by the Employment and Training Administration. Every trainee must be paid at not less than the rate specified in the approved program for the trainee's level of progress, expressed as a percentage of the journeyman's hourly rate specified in the applicable wage determination. Trainees shall be paid fringe benefits in accordance with the provisions of the trainee program. If the trainee program does not mention fringe benefits, trainees shall be paid the full amount of fringe benefits listed on the wage determination unless the Administrator of the Wage and Hour Division determines that there is an apprenticeship program associated with the corresponding journeyman wage rate on the wage determination which provides for less than full fringe benefits for apprentices. Any employee listed on the payroll at a trainee rate who is not registered and participating in a training plan approved by the Employment and Training Administration shall be paid not less than the applicable wage rate on the wage determination for the classification of work actually performed. In addition, any trainee performing work on the job site in excess of the ratio permitted under the registered program shall be paid not less than the applicable wage rate on the wage determination for the work actually performed. In the event the Employment and Training Administration withdraws approval of a training program, the Contractor will no longer be permitted to utilize trainees at less than the applicable predetermined rate for the work performed until an acceptable program is approved.

(3) **Equal employment opportunity.** The utilization of apprentices, trainees and journeymen under this part shall be in conformity with the equal employment opportunity

requirements of Executive Order 11246, *Equal Employment Opportunity*, as amended, and 29 C.F.R. part 30.

(e) **Compliance with Copeland Anti-Kickback Act Requirements.** The Contractor shall comply with the Copeland Anti-Kickback Act (18 U.S.C. § 874 and 40 U.S.C. § 3145) as supplemented by Department of Labor regulations (29 C.F.R. part 3, “Contractors and Subcontractors on Public Buildings or Public Works Financed in Whole or in Part by Loans or Grants of the United States”). The Act provides that the Contractor and any subcontractors shall be prohibited from inducing, by any means, any person employed in the construction, completion, or repair of public work, to give up any part of the compensation to which they are otherwise entitled. The Owner shall report all suspected or reported violations to EDA.

(f) **Subcontracts.** The Contractor and any subcontractors will insert in any subcontracts the clauses contained in 29 C.F.R. §§ 5.5(a)(1) through (10) and such other clauses as EDA or its designee may require, and also a clause requiring the subcontractors to include these clauses in any lower tier subcontracts. The prime Contractor shall be responsible for the compliance by any subcontractor or lower tier subcontractor with all the contract clauses in 29 C.F.R. § 5.5.

(g) **Contract termination; debarment.** The breach of the contract clauses in 29 C.F.R. § 5.5 may be grounds for termination of the contract, and for debarment as a Contractor and a subcontractor as provided in 29 C.F.R. § 5.12.

(h) **Compliance with Davis-Bacon and Related Act Requirements.** All rulings and interpretations of the Davis-Bacon and Related Acts contained in 29 C.F.R. parts 1, 3, and 5 are herein incorporated by reference in this contract.

(i) **Disputes concerning labor standards.** Disputes arising out of the labor standards provisions of this Contract shall not be subject to the general disputes clause of this Contract. Such disputes shall be resolved in accordance with the procedures of the Department of Labor set forth in 29 C.F.R. parts 5, 6, and 7. Disputes within the meaning of this clause include disputes between the contractor (or any of its subcontractors) and EDA or its designee, the U.S. Department of Labor, or the employees or their representatives.

(j) **Certification of Eligibility.**

(1) By entering into this Contract, the Contractor certifies that neither it nor any person or firm that has an interest in the Contractor's firm is a person or firm ineligible to be awarded Government contracts by virtue of section 3(a) of the Davis-Bacon Act or 29 C.F.R. § 5.12(a)(1).

(2) No part of this Contract shall be subcontracted to any person or firm ineligible for award of a Government contract by virtue of section 3(a) of the Davis-Bacon Act or 29 C.F.R. § 5.12(a)(1).

(3) The penalty for making false statements is prescribed in the U.S. Criminal Code, 18 U.S.C. § 1001.

16. **LABOR STANDARDS - CONTRACT WORK HOURS AND SAFETY STANDARDS ACT**

As used in this paragraph, the terms “laborers” and “mechanics” include watchmen and guards.

(a) **Overtime requirements.** No Contractor or subcontractor contracting for any part of the Contract work, which may require or involve the employment of laborers or mechanics, shall require or permit any such laborer or mechanic in any workweek in which that person is employed on such work to work in excess of forty hours in such workweek unless such laborer or mechanic receives compensation at a rate not less than one and one-half times the basic rate of pay for all hours worked in excess of forty hours in such workweek.

(b) **Violation; liability for unpaid wages, liquidated damages.** In the event of any violation of the clause set forth in paragraph (a) of this section, the Contractor and any subcontractor responsible therefore shall be liable for the unpaid wages. In addition, such Contractor and subcontractor shall be liable to the United States (in the case of work done under contract for the District of Columbia or a territory, to such District or to such territory), for liquidated damages. Such liquidated damages shall be computed with respect to each individual laborer or mechanic, including watchmen and guards, employed in violation of the clause set forth in paragraph (a) of this section, in the sum of \$10 for each calendar day on which such individual was required or permitted to work in excess of the standard workweek of forty hours without payment of the overtime wages required by the clause set forth in paragraph (a) of this section.

(c) **Withholding for unpaid wages and liquidated damages.** EDA or its designee shall upon its own action or upon written request of an authorized representative of the Department of Labor withhold or cause to be withheld, from any monies payable on account of work performed by the Contractor or subcontractor under any such Contract or any other federal contract with the same prime Contractor, or any other federally-assisted contract subject to the Contract Work Hours and Safety Standards Act, which is held by the same prime Contractor such sums as may be determined to be necessary to satisfy any liabilities of such Contractor or subcontractor for unpaid wages and liquidated damages as provided in the clause set forth in paragraph (b) of this section.

(d) **Subcontracts.** The Contractor or subcontractor shall insert in any subcontracts the clauses set forth in paragraphs (a) through (c) of this section and also a clause requiring the subcontractors to include these clauses in any lower tier subcontracts. The prime Contractor shall be responsible for compliance by any subcontractor or lower tier subcontractor with the clauses set forth in paragraphs (a) through (c) of this section.

17. **EQUAL EMPLOYMENT OPPORTUNITY**

(a) The Recipient hereby agrees that it will incorporate or cause to be incorporated into any contract for construction work, or modification thereof, as defined in the regulations of the Secretary of Labor at 41 C.F.R. chapter 60, which is paid for in whole or in part with funds obtained from EDA, the following equal opportunity clause:

During the performance of this contract, the Contractor agrees as follows:

(1) The Contractor will not discriminate against any employee or applicant for employment because of race, color, religion, sex, sexual orientation, gender identity, or national origin. The Contractor will take affirmative action to ensure that applicants are employed, and that employees are treated during employment without regard to their race, color, religion, sex, sexual orientation, gender identity, or national origin. Such action shall include, but not be limited to the following: Employment, upgrading, demotion, or transfer; recruitment or recruitment advertising; layoff or termination; rates of pay or other forms of compensation; and selection for training including apprenticeship. The Contractor agrees to post in conspicuous places available to employees and applicants for employment notices to be provided setting forth the provisions of this nondiscrimination clause.

(2) The Contractor will, in all solicitations or advertisements for employees placed by or on behalf of the Contractor state that all qualified applicants will receive consideration for employment without regard to race, color, religion, sex, sexual orientation, gender identity, or national origin.

(3) The contractor will not discharge or in any other manner discriminate against any employee or applicant for employment because such employee or applicant has inquired about, discussed, or disclosed the compensation of the employee or applicant or another employee or applicant. This provision shall not apply to instances in which an employee who has access to the compensation information of other employees or applicants as a part of such employee's essential job functions discloses the compensation of such other employees or applicants to individuals who do not otherwise have access to such information, unless such disclosure is in response to a formal complaint or charge, in furtherance of an investigation, proceeding, hearing, or action, including an investigation conducted by the employer, or is consistent with the contractor's legal duty to furnish information.

(4) The Contractor will send to each labor union or representative of workers with which it has a collective bargaining agreement or other contract or understanding, a notice to be provided advising the said labor union or workers representatives of the Contractor's commitments hereunder, and shall post copies of the notice in conspicuous places available to employees and applicants for employment.

(5) The Contractor will comply with all provisions of Executive Order 11246 of September 24, 1965 and of the rules, regulations, and relevant orders of the Secretary of Labor.

(6) The Contractor will furnish all information and reports required by Executive Order 11246 of September 24, 1965, and by rules, regulations, and orders of the Secretary of Labor, or pursuant thereto, and will permit access to its books, records, and accounts by EDA and the Secretary of Labor for purposes of investigation to ascertain compliance with such rules, regulations, and orders.

(7) In the event of the Contractor's noncompliance with the nondiscrimination clauses of

this Contract or with any of the said rules, regulations, or orders, this Contract may be canceled, terminated, or suspended in whole or in part and the Contractor may be declared ineligible for further Government contracts or federally-assisted construction contracts in accordance with procedures authorized in Executive Order 11246 of September 24, 1965, and such other sanctions may be imposed and remedies invoked as provided in Executive Order 11246 of September 24, 1965, or by rule, regulation or order of the Secretary of Labor, or as otherwise provided by law.

(8) The Contractor will include the portion of the sentence immediately preceding paragraph 17(a)(1) and the provisions of paragraphs 17(a)(1) through (8) in every subcontract or purchase order unless exempted by rules, regulations, or orders of the Secretary of Labor issued pursuant to section 204 of Executive Order 11246 of September 24, 1965, so that such provisions will be binding upon each subcontractor or vendor. The Contractor will take such action with respect to any subcontract or purchase order as EDA or the Secretary of Labor may direct as a means of enforcing such provisions, including sanctions for noncompliance. Provided, however, that in the event the Contractor becomes involved in or is threatened with litigation with a subcontractor or vendor as a result of such direction by EDA or the Secretary of Labor, the Contractor may request the United States to enter into such litigation to protect the interests of the United States.

(9) The Recipient further agrees that it will be bound by the above equal opportunity clause with respect to its own employment practices when it participates in federally-assisted construction work. Provided, however, that if the Recipient so participating is a State or local government, the above equal opportunity clause is not applicable to any agency, instrumentality, or subdivision of such government that does not participate in work on or under the Contract.

(10) The Recipient agrees that it will assist and cooperate actively with EDA and the Secretary of Labor in obtaining the compliance of contractors and subcontractors with the equal opportunity clause and the rules, regulations, and relevant orders of the Secretary of Labor, that it will furnish EDA and the Secretary of Labor such information as they may require for the supervision of such compliance, and that it will otherwise assist EDA in the discharge of the EDA's primary responsibility for securing compliance.

(11) The Recipient further agrees that it will refrain from entering into any contract or contract modification subject to Executive Order 11246 of September 24, 1965, with a Contractor debarred from, or who has not demonstrated eligibility for, Government contracts and federally assisted construction contracts pursuant to the Executive Order and will carry out such sanctions and penalties for violation of the equal opportunity clause as may be imposed upon contractors and subcontractors by EDA or the Secretary of Labor pursuant to Part II, Subpart D of the Executive Order. In addition, the Recipient agrees that if it fails or refuses to comply with these undertakings, EDA may take any or all of the following actions: Cancel, terminate, or suspend in whole or in part this EDA financial assistance; refrain from extending any further assistance to the applicant under the program with respect to which the failure or refund occurred until satisfactory assurance of future compliance has been received from such applicant; and refer the case

to the Department of Justice for appropriate legal proceedings.

(b) Exemptions to Above Equal Opportunity Clause (41 C.F.R. chapter 60):

(1) Contracts and subcontracts not exceeding \$10,000 (other than Government bills of lading, and other than contracts and subcontracts with depositories of Federal funds in any amount and with financial institutions which are issuing and paying agents for U.S. savings bonds and savings notes) are exempt. The amount of the Contract, rather than the amount of the federal financial assistance, shall govern in determining the applicability of this exemption.

(2) Except in the case of subcontractors for the performance of construction work at the site of construction, the clause shall not be required to be inserted in subcontracts below the second tier.

(3) Contracts and subcontracts not exceeding \$10,000 for standard commercial supplies or raw materials are exempt.

18. **CONTRACTING WITH SMALL, MINORITY AND WOMEN'S BUSINESSES**

(a) If the Contractor intends to let any subcontracts for a portion of the work, the Contractor shall take affirmative steps to assure that small, minority and women's businesses are used when possible as sources of supplies, equipment, construction, and services.

(b) Affirmative steps shall consist of:

(1) Placing qualified small and minority businesses and women's business enterprises on solicitation lists;

(2) Ensuring that small and minority businesses and women's business enterprises are solicited whenever they are potential sources;

(3) Dividing total requirements, when economically feasible, into smaller tasks or quantities to permit maximum participation by small and minority businesses and women's business enterprises;

(4) Establishing delivery schedules, where the requirements of the contract permit, which encourage participation by small and minority businesses and women's business enterprises;

(5) Using the services and assistance of the U.S. Small Business Administration, the Minority Business Development Agency of the U.S. Department of Commerce, and State and local governmental small business agencies;

(6) Requiring each party to a subcontract to take the affirmative steps of this section; and

(7) The Contractor is encouraged to procure goods and services from labor surplus area firms.

19. **HEALTH, SAFETY, AND ACCIDENT PREVENTION**

(a) In performing this contract, the Contractor shall:

(1) Ensure that no laborer or mechanic shall be required to work in surroundings or under working conditions which are unsanitary, hazardous, or dangerous to their health and/or safety as determined under construction safety and health standards promulgated by the Secretary of Labor by regulation;

(2) Protect the lives, health, and safety of other persons;

(3) Prevent damage to property, materials, supplies, and equipment; and

(4) Avoid work interruptions.

(b) For these purposes, the Contractor shall:

(1) Comply with regulations and standards issued by the Secretary of Labor at 29 C.F.R. part 1926. Failure to comply may result in imposition of sanctions pursuant to the Contract Work Hours and Safety Standards Act (40 U.S.C. §§ 3701 – 3708); and

(2) Include the terms of this clause in every subcontract so that such terms will be binding on each subcontractor.

(c) The Contractor shall maintain an accurate record of exposure data on all accidents incident to work performed under this Contract resulting in death, traumatic injury, occupational disease, or damage to property, materials, supplies, or equipment, and shall report this data in the manner prescribed by 29 C.F.R. part 1904.

(d) The Owner shall notify the Contractor of any noncompliance with these requirements and of the corrective action required. This notice, when delivered to the Contractor or the Contractor's representative at the site of the Work, shall be deemed sufficient notice of the noncompliance and corrective action required. After receiving the notice, the Contractor shall immediately take corrective action. If the Contractor fails or refuses to take corrective action promptly, the Owner may issue an order stopping all or part of the Work until satisfactory corrective action has been taken. The Contractor shall not base any claim or request for equitable adjustment for additional time or money on any stop order issued under these circumstances.

(e) The Contractor shall be responsible for its subcontractors' compliance with the provisions of this clause. The Contractor shall take such action with respect to any subcontract as EDA, or the Secretary of Labor shall direct as a means of enforcing such provisions.

20. **CONFLICT OF INTEREST AND OTHER PROHIBITED INTERESTS**

- (a) No official of the Owner who is authorized in such capacity and on behalf of the Owner to negotiate, make, accept, or approve, or to take part in negotiating, making, accepting, or approving any architectural, engineering, inspection, construction or material supply contract or any subcontract in connection with the construction of the Project, shall become directly or indirectly interested personally in this Contract or in any part hereof.
- (b) No officer, employee, architect, attorney, engineer, or inspector of or for the Owner who is authorized in such capacity and on behalf of the Owner to exercise any legislative, executive, supervisory or other similar functions in connection with the construction of the Project, shall become directly or indirectly interested personally in this Contract or in any part thereof, any material supply contract, subcontract, insurance contract, or any other contract pertaining to the Project.
- (c) The Contractor may not knowingly contract with a supplier or manufacturer if the individual or entity who prepared the Contract Documents has a corporate or financial affiliation with the supplier or manufacturer.
- (d) The Owner's officers, employees, or agents shall not engage in the award or administration of this Contract if a conflict of interest, real or apparent, may be involved. Such a conflict may arise when: (i) the employee, officer or agent; (ii) any member of their immediate family; (iii) their partner or (iv) an organization that employs, or is about to employ, any of the above, has a financial interest in the Contractor. The Owner's officers, employees, or agents shall neither solicit nor accept gratuities, favors, or anything of monetary value from the Contractor or subcontractors.
- (e) If the Owner finds after a notice and hearing that the Contractor, or any of the Contractor's agents or representatives, offered or gave gratuities (in the form of entertainment, gifts, or otherwise) to any official, employee, or agent of the Owner or EDA in an attempt to secure this Contract or favorable treatment in awarding, amending, or making any determinations related to the performance of this Contract, the Owner may, by written notice to the Contractor, terminate this Contract. The Owner may also pursue other rights and remedies that the law or this Contract provides. However, the existence of the facts on which the Owner bases such findings shall be an issue and may be reviewed in proceedings under the dispute resolution provisions of this Contract.
- (f) In the event this Contract is terminated as provided in paragraph (e) of this section, the Owner may pursue the same remedies against the Contractor as it could pursue in the event of a breach of this Contract by the Contractor. As a penalty, in addition to any other damages to which it may be entitled by law, the Owner may pursue exemplary damages in an amount (as determined by the Owner) which shall not be less than three nor more than ten times the costs the Contractor incurs in providing any such gratuities to any such officer or employee.

21. RESTRICTIONS ON LOBBYING

(a) This Contract, or subcontract is subject to 31 U.S.C. § 1352, regarding lobbying restrictions. The section is explained in the common rule, 15 C.F.R. part 28 (55 FR 6736-6748, February 26, 1990). Each bidder under this Contract or subcontract is generally prohibited from using federal funds for lobbying the Executive or Legislative Branches of the Federal Government in connection with this EDA Award.

(b) **Contract Clause Threshold:** This Contract Clause regarding lobbying must be included in each bid for a contract or subcontract exceeding \$100,000 of federal funds at any tier under the EDA Award.

(c) **Certification and Disclosure:** Each bidder of a contract or subcontract exceeding \$100,000 of federal funds at any tier under the federal Award must file Form CD-512, *Certification Regarding Lobbying – Lower Tier Covered Transactions*, and, if applicable, Standard Form-LLL, *Disclosure of Lobbying Activities*, regarding the use of any nonfederal funds for lobbying. Certifications shall be retained by the Contractor or subcontractor at the next higher tier. All disclosure forms, however, shall be forwarded from tier to tier until received by the Recipient of the EDA Award, who shall forward all disclosure forms to EDA.

(d) **Continuing Disclosure Requirement:** Each Contractor or subcontractor that is subject to the Certification and Disclosure provision of this Contract Clause is required to file a disclosure form at the end of each calendar quarter in which there occurs any event that requires disclosure or that materially affects the accuracy of the information contained in any disclosure form previously filed by such person. Disclosure forms shall be forwarded from tier to tier until received by the Recipient of the EDA Award, who shall forward all disclosure forms to EDA.

(e) **Indian Tribes, Tribal Organizations, or Other Indian Organizations:** Indian tribes, tribal organizations, or any other Indian organizations, including Alaskan Native organizations, are excluded from the above lobbying restrictions and reporting requirements, but only with respect to expenditures that are by such tribes or organizations for lobbying activities permitted by other federal law. An Indian tribe or organization that is seeking an exclusion from Certification and Disclosure requirements must provide EDA with the citation of the provision or provisions of federal law upon which it relies to conduct lobbying activities that would otherwise be subject to the prohibitions in and to the Certification and Disclosure requirements of 31 U.S.C. § 1352, preferably through an attorney's opinion. Note, also, that a non-Indian subrecipient, contractor, or subcontractor under an award to an Indian tribe, for example, is subject to the restrictions and reporting requirements.

22. HISTORICAL AND ARCHAEOLOGICAL DATA PRESERVATION

The Contractor agrees to facilitate the preservation and enhancement of structures and objects of historical, architectural or archaeological significance and when such items are found and/or unearthed during the course of project construction. Any excavation by the Contractor that uncovers an historical or archaeological artifact shall be immediately reported to the Owner and a representative of EDA. Construction shall be temporarily halted pending the notification process and further directions issued by EDA after consultation with the State Historic

Preservation Officer (SHPO) for recovery of the items. *See* the National Historic Preservation Act of 1966 (54 U.S.C. § 300101 *et seq.*, formerly at 16 U.S.C. § 470 *et seq.*) and Executive Order No. 11593 of May 31, 1971.

23. **CLEAN AIR AND WATER**

Applicable to Contracts in Excess of \$150,000

(a) **Definition.** “Facility” means any building, plant, installation, structure, mine, vessel, or other floating craft, location, or site of operations, owned, leased, or supervised by the Contractor or any subcontractor, used in the performance of the Contract or any subcontract. When a location or site of operations includes more than one building, plant, installation, or structure, the entire location or site shall be deemed a facility except when the Administrator, or a designee, of the United States Environmental Protection Agency (EPA) determines that independent facilities are collocated in one geographical area.

(b) In compliance with regulations issued by the EPA, 2 C.F.R. part 1532, pursuant to the Clean Air Act, as amended (42 U.S.C. § 7401 *et seq.*); the Federal Water Pollution Control Act, as amended (33 U.S.C. § 1251 *et seq.*); and Executive Order 11738, the Contractor agrees to:

(1) Not utilize any facility in the performance of this contract or any subcontract which is listed on the Excluded Parties List System, part of the System for Award Management (SAM), pursuant to 2 C.F.R. part 1532 for the duration of time that the facility remains on the list;

(2) Promptly notify the Owner if a facility the Contractor intends to use in the performance of this contract is on the Excluded Parties List System or the Contractor knows that it has been recommended to be placed on the List;

(3) Comply with all requirements of the Clean Air Act and the Federal Water Pollution Control Act, including the requirements of section 114 of the Clean Air Act and section 308 of the Federal Water Pollution Control Act, and all applicable clean air and clean water standards; and

(4) Include or cause to be included the provisions of this clause in every subcontract and take such action as EDA may direct as a means of enforcing such provisions.

24. **USE OF LEAD-BASED PAINTS ON RESIDENTIAL STRUCTURES**

(a) If the work under this Contract involves construction or rehabilitation of residential structures over \$5,000, the Contractor shall comply with the Lead-based Paint Poisoning Prevention Act (42 U.S.C. § 4831). The Contractor shall assure that paint or other surface coatings used in a residential property does not contain lead equal to or in excess of 1.0 milligram per square centimeter or 0.5 percent by weight or 5,000 parts per million (ppm) by weight. For purposes of this section, “residential property” means a dwelling unit, common areas, building exterior surfaces, and any surrounding land, including outbuildings, fences and play equipment affixed to the land, belonging to an owner and available for use by residents, but not

including land used for agricultural, commercial, industrial or other non-residential purposes, and not including paint on the pavement of parking lots, garages, or roadways.

- (b) As a condition to receiving assistance under PWEDA, recipients shall assure that the restriction against the use of lead-based paint is included in all contracts and subcontracts involving the use of federal funds.

25. **ENERGY EFFICIENCY**

The Contractor shall comply with all standards and policies relating to energy efficiency which are contained in the energy conservation plan issued in compliance with the Energy Policy and Conservation Act (42 U.S.C. § 6201) for the State in which the Work under the Contract is performed.

26. **ENVIRONMENTAL REQUIREMENTS**

When constructing a Project involving trenching and/or other related earth excavations, the Contractor shall comply with the following environmental constraints:

- (1) **Wetlands.** When disposing of excess, spoil, or other construction materials on public or private property, the Contractor shall not fill in or otherwise convert wetlands.
- (2) **Floodplains.** When disposing of excess, spoil, or other construction materials on public or private property, the Contractor shall not fill in or otherwise convert 100 year floodplain areas delineated on the latest Federal Emergency Management Agency (FEMA) Floodplain Maps, or other appropriate maps, i.e., alluvial soils on Natural Resource Conservation Service (NRCS) Soil Survey Maps.
- (3) **Endangered Species.** The Contractor shall comply with the Endangered Species Act, which provides for the protection of endangered and/or threatened species and critical habitat. Should any evidence of the presence of endangered and/or threatened species or their critical habitat be brought to the attention of the Contractor, the Contractor will immediately report this evidence to the Owner and a representative of EDA. Construction shall be temporarily halted pending the notification process and further directions issued by EDA after consultation with the U.S. Fish and Wildlife Service.

27. **DEBARMENT, SUSPENSION, INELIGIBILITY, AND VOLUNTARY EXCLUSIONS**

As required by Executive Orders 12549 and 12689, *Debarment and Suspension*, 2 C.F.R. Part 180 and implemented by the Department of Commerce at 2 C.F.R. part 1326, for prospective participants in lower tier covered transactions (except subcontracts for goods or services under the \$25,000 small purchase threshold unless the subrecipient will have a critical influence on or substantive control over the award), the Contractor agrees that:

- (1) By entering into this Contract, the Contractor and subcontractors certify, that neither it nor its principals is presently debarred, suspended, proposed for debarment, declared Economic Development Administration Contracting Provisions for Construction Projects

ineligible, or voluntarily excluded from participation in this Contract by any federal department or agency.

(2) Where the Contractor or subcontractors are unable to certify to any of the statements in this certification, the Contractor or subcontractors shall attach an explanation to this bid.

See also 2 C.F.R. part 180 and 2 C.F.R. § 200.342.

28. **EDA PROJECT SIGN**

The Contractor shall supply, erect, and maintain in good condition a Project sign according to the specifications provided by EDA. To the extent practical, the sign should be a free standing sign. Project signs shall not be located on public highway rights-of-way. Location and height of signs will be coordinated with the local agency responsible for highway or street safety in the Project area, if any possibility exists for obstructing vehicular traffic line of sight. Whenever the EDA site sign specifications conflict with State law or local ordinances, the EDA Regional Director will permit such conflicting specifications to be modified so as to comply with State law or local ordinance.

29. **BUY AMERICA**

To the greatest extent practicable, contractors are encouraged to purchase American-made equipment and products with funding provided under EDA financial assistance awards.

EDA PROJECT SIGN

The Contractor shall supply, erect, and maintain in good condition a project sign according to the specifications set forth below:

EDA SITE SIGN SPECIFICATIONS

Size: 4' x 8' x ¾"

Materials: Exterior grade/MDO plywood (APA rating A-B)

Supports: 4" x 4" x 12' posts with 2" x 4" cross branching

Erection: Posts shall be set a minimum of three feet deep in concrete footings that are at least 12" in diameter.

Paint: Outdoor enamel

Colors: Jet Black, Blue (PMS300), and Gold (PMS7406). Specifically, on white background the following will be placed:

The U. S. Department of Commerce seal in blue, black, and gold;

“EDA” in blue;

“U. S. DEPARTMENT OF COMMERCE ECONOMIC DEVELOPMENT
ADMINISTRATION” in black;

“In partnership with” in blue;

(Actual name of the) “EDA Grant Recipient” in black;

Lettering: Specific fonts are named below; positioning will be as shown on the attached illustration.

“U. S. DEPARTMENT OF COMMERCE ECONOMIC DEVELOPMENT
ADMINISTRATION” use Bank Gothic Medium - **BANK GOTHIC MED**

“In partnership with” use Univers™ 55 Oblique - **Univers 55**

(Name of) “EDA Grant Recipient” use Univers™ Extra Black 85 **Univers 85**

Project signs will not be erected on public highway rights-of-way. If any possibility exists for obstruction to traffic line of sight, the location and height of the sign will be coordinated with the agency responsible for highway or street safety in the area.

The EDA Regional Director may permit modifications to these specifications if they conflict with state law or local ordinances.

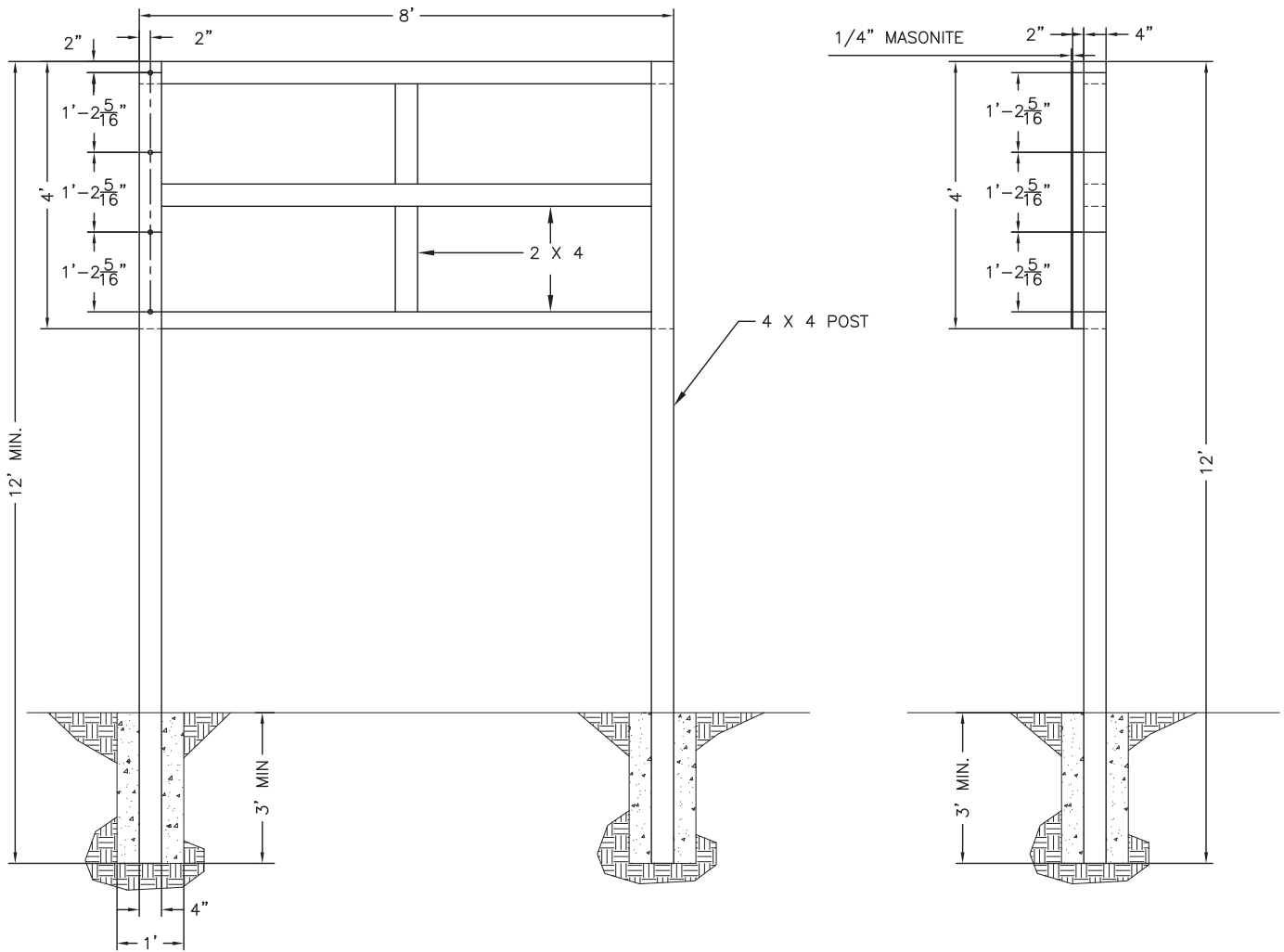

SIGN A
MASONITE SIGN
SCALE: 3/8" = 1'

PROJECT - SIGN A

ECONOMIC DEVELOPMENT ADMINISTRATION

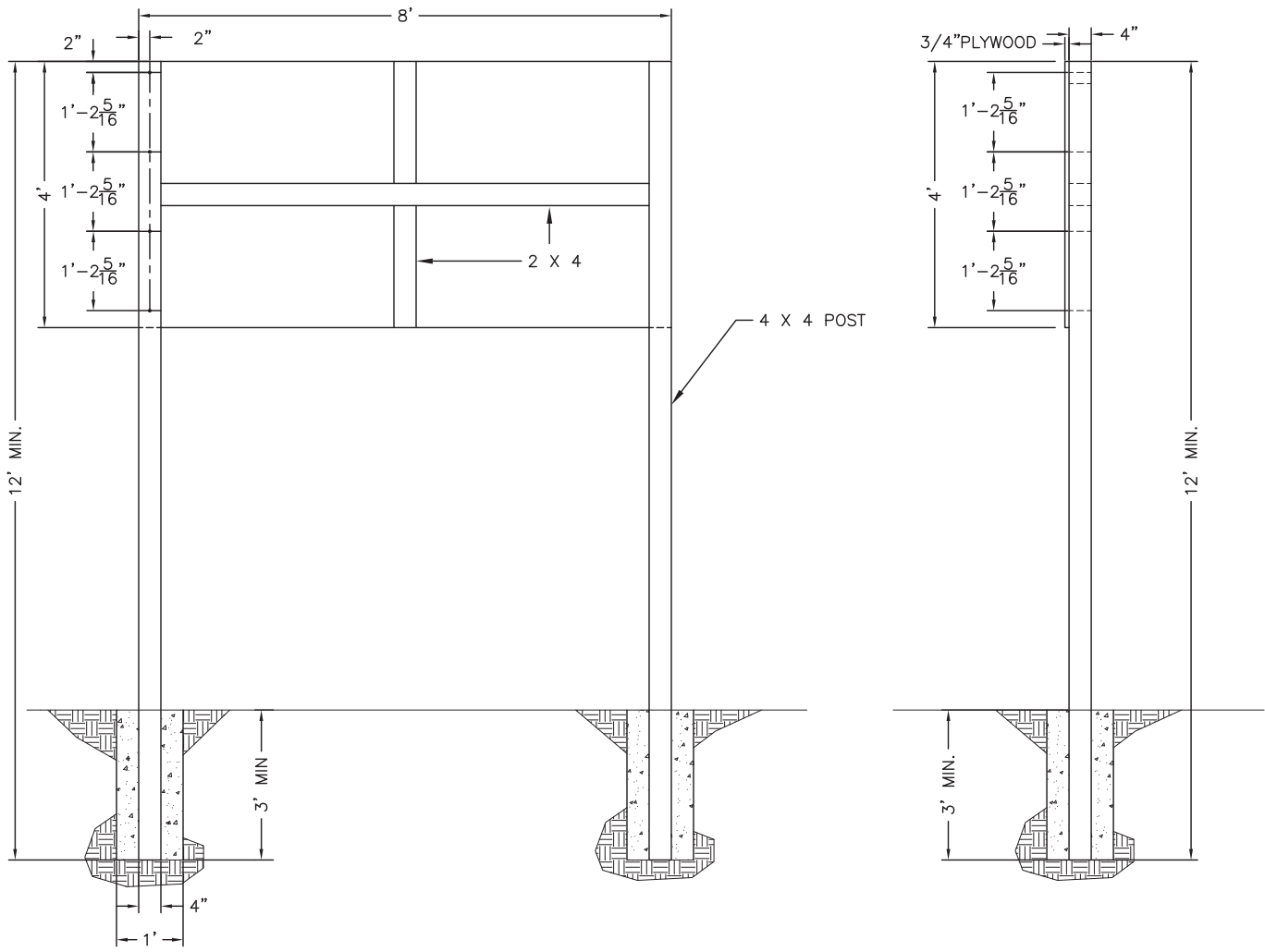

SIGN B
PLYWOOD SIGN
SCALE: 3/8" = 1'

PROJECT - SIGN B

ECONOMIC DEVELOPMENT ADMINISTRATION

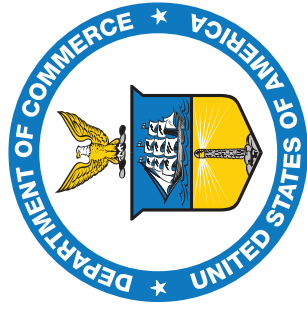

EDA

U.S. DEPARTMENT OF COMMERCE ECONOMIC DEVELOPMENT ADMINISTRATION

In partnership with

<EDA Grant Recipient Name>

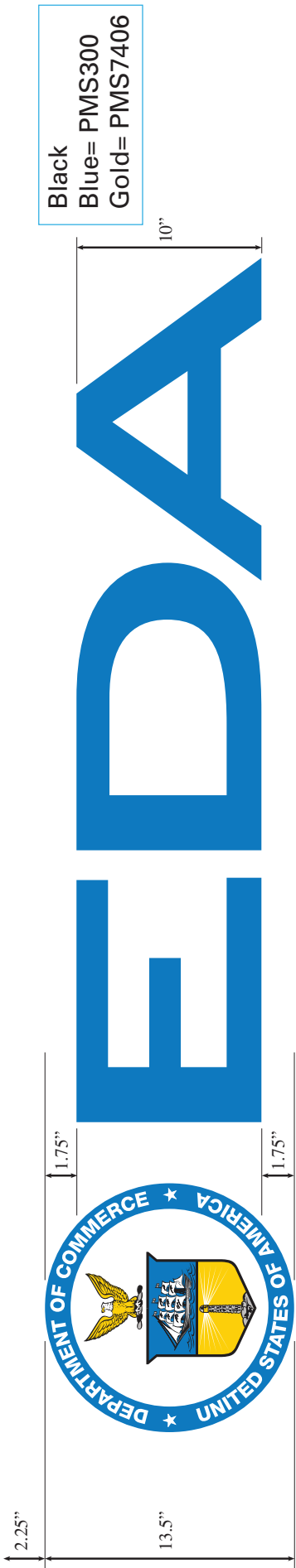

Black
Blue= PMS300
Gold= PMS7406

U.S. DEPARTMENT OF COMMERCE ECONOMIC DEVELOPMENT ADMINISTRATION

In partnership with

<EDA Grant Recipient Name>

