

PUTNAM COUNTY



**CONTRACT DOCUMENTS
FOR**

PROJECT NO. 22-42001-001

PEA RIDGE ROAD RESURFACING

**PUTNAM COUNTY
BOARD OF COMMISSIONERS**

SECTION I

BID PROPOSAL

TABLE OF CONTENTS

- Special Notice
- Notice to Contractors
- Bid Form
- Schedule of Items
- Bid Bond
- Corporate Certificate
- Oath of Successful Bidder
- Contractor Affidavit and Agreement
- SAVE Affidavit
- List of Subcontractors

SPECIAL NOTICE

60 CALENDAR DAYS ARE ALLOWED FOR CONSTRUCTION ON PROJECT NO. 22-42001-001 PEA RIDGE ROAD RESURFACING. CONTRACTOR WILL BE ASSESSED LIQUIDATED DAMAGES IN THE AMOUNT OF \$500 PER CALENDAR DAY FOR FAILURE TO COMPLETE THE PROJECT ON SCHEDULE.

SECTION I

NOTICE TO CONTRACTORS

Sealed bids will be received by the Board of Commissioners of Putnam County, Georgia, 117 Putnam Drive, Suite A, Eatonton, Georgia 31024 until 10:00 a.m. local time, **April 21, 2022** for:

22-42001-001
PEA RIDGE ROAD RESURFACING

Scope of work consists of the following:

- Approximately 8.02 miles of asphalt overlay of Pea Ridge Road from Sparta Highway to US 441 (Milledgeville Highway). The scope includes traffic control, clipping the shoulders prior to paving, tack coat, open graded crack relief, asphalt overlay, rumble strips, striping, raised pavement markings, and pulling soil/grass materials to the edge of the road upon completion.

Bids received after the stated time will not be accepted. At 10:00 a.m. local time on the above date, the bids will be publicly opened and read aloud.

The Bid shall be submitted in duplicate in a sealed envelope clearly marked 'PROJECT NO. 22-42001-001 PEA RIDGE ROAD RESURFACING BID PROPOSAL FOR PUTNAM COUNTY,' and include:

1. Completed Bid Form
2. Bid Bond, Certified Check or Cashier's Check
3. Corporate Certificate
4. Oath of Successful Bidder
5. References
6. List of Subcontractors
7. Schedule of Items
8. Contractor Affidavit and Agreement (E-verify)
9. SAVE Affidavit

Bidding Documents are available for viewing at the Putnam Board of Commissioners Office, Putnam County, Georgia, 117 Putnam Drive, Suite A, Eatonton, Georgia 31024. The Bidding Documents may be obtained at no charge from:

Atlas Technical Consultants LLC
Attn: Russell Small
2450 Commerce Avenue, Suite 100
Duluth, Georgia 30096-8910
Email: russell.small@oneatlas.com
Phone (770)263-5945, Cell (678)641-5246

Putnam County does not discriminate on the basis of disability in the admission or access to its programs or activities. Any requests for reasonable accommodations required by individuals to fully participate in any open meeting, program or activity of Putnam County Government should be directed to Mr. Paul Van Haute, County Manager, 706-485-5826.

All bidders must submit with bid, a bid bond, certified check, or cashier's check in the amount of five percent (5%) of the total bid. Successful bidder will be required to meet insurance requirements, submit a one hundred percent (100%) performance bond and a one hundred percent (100%) payment bond. Insurance and Bonding Company must be authorized to do business in Georgia by The Georgia Insurance Department, listed in the Department of Treasury's Publication of Companies holding Certificates of Authority as Acceptable Surety on Federal Bonds and as acceptable reinsuring companies, and must have an A.M. Best rating of A-5 or higher.

Individuals, firms, and businesses seeking an award of a Putnam County contract may not initiate or continue any verbal or written communications regarding a solicitation with any County officer, elected official, employee or other County representative without permission of the Putnam County Manager named in the solicitation between the date of the issuance of the solicitation and the date of the final contract award by the Board of Commissioners. Violations will be reviewed by the County Manager. If determined that such communication has compromised the competitive process, the offer submitted by the individual, firm or business may be disqualified from consideration for award.

Questions regarding Bidding Documents and Specifications should be directed to Russell Small, at russell.small@oneatlas.com no later than April 14, 2022 by 5:00 p.m.

The written bid documents supersede any verbal or written prior communications between the parties.

Award will be made to the lowest responsible and responsive bidder. Putnam County reserves the right to reject any or all bids, to waive technicalities, and to make an award as deemed in its best interest. Where Putnam County provides forms for bid schedule and bond submissions, these forms must be used without exception.

All companies submitting a bid will be notified of award.

The Bidding Documents consist of the following, including all addenda issued therewith and forms referenced therein:

Section I - Bid Proposal
Section II - Contract Documents

To: THE BOARD OF COMMISSIONERS
PUTNAM COUNTY, GEORGIA
EATONTON, GEORGIA 31024

Gentlemen:

In compliance with your Notice to Contractors, the undersigned, hereinafter termed the Bidder, proposes to enter into a Contract with Putnam County, to provide the necessary machinery, tools, apparatus, and other means of construction, and all materials and labor specified in the Contract, or necessary to complete the Work in the manner therein specified within the time specified, as therein set forth, for:

22-42001-001
PEA RIDGE ROAD RESURFACING

The Bidder has carefully examined and fully understands the Contract and Specifications, and other Documents hereto attached, and has made a personal examination of the Site of the proposed Work and has satisfied himself as to the actual conditions and requirements of the Work, and hereby proposes and agrees that if his bid is accepted, he will contract with Putnam County full conformance with the Contract Documents.

Unless otherwise directed, all work performed shall be in accordance with the Georgia Department of Transportation Standard Specifications Construction of Transportation Systems, 2021 Edition, General Conditions, Supplements thereto (Published and Not Published) and Special Provisions modifying them. All materials used in the process of completion of the work included in the contract will be furnished from Georgia Department of Transportation certified suppliers only.

It is the intent of this Bid to include all items of construction and called for in the Specifications.

In accordance with the foregoing, the undersigned proposes to furnish and construct the items listed in the attached Schedule of Items for the unit prices stated.

The Bidder agrees that the cost of any work performed, materials furnished, services provided, or expenses incurred, which are not specifically delineated in the Contract Documents, but which are incidental to the scope, intent, and completion of the Contract, shall be deemed to have been included in the prices bid for the various items scheduled.

The Bidder further proposes and agrees hereby to promptly commence the Work with adequate forces and equipment within ten (10) calendar days from receipt of Notice to Proceed, and to complete the work on project 22-42001-001 Pea Ridge Road Resurfacing in 60 calendar days. If said work is not completed within the time stated, the Contractor shall be liable and hereby agrees to pay the County as liquidated damages and not as a penalty, \$500 per calendar day for failure to complete the work in 60 calendar days, all as liquidation of the extra expense incurred by the county and liquidated damages to the county. Liquidated damages will continue until the contract is complete.

If this bid shall be accepted by Putnam County and the undersigned shall fail to execute a satisfactory contract in the form of said proposed Contract, and give satisfactory Performance and Payment Bonds, or furnish satisfactory proof of carriage of the insurance required, within

ten days from the date of Notice of Award of the Contract, then Putnam County may at its option, determine that the undersigned abandoned the Contract and thereupon this bid shall be null and void, and the sum stipulated in the attached Bid Bond or certified check shall be forfeited to Putnam County as liquidated damages.

Bidder acknowledges receipt of the following addenda:

| <u>Addendum No.</u> | <u>Date Received</u> |
|---------------------|----------------------|
| _____ | _____ |
| _____ | _____ |
| _____ | _____ |
| _____ | _____ |

Bidder further declares that the full name and resident address of all persons and parties interested in the foregoing bid as principals, are as follows:

Signed, sealed, and dated this _____ day of _____, 20_____.

Bidder: _____ (Seal)
Company Name

Bidder Mailing Address:

By: _____

Title: _____

By: _____

Title: _____

| | |
|-------------------------------|----------------------------|
| PUTNAM COUNTY, GEORGIA | |
| PROJECT: | PEA RIDGE ROAD RESURFACING |
| BID NUMBER: | 22-42001-001 |

BID SCHEDULE

| Item # | GDOT # | Description | Units | Est. Bid Quantity | Unit Price Bid | Total Price Bid |
|--------|----------|---|-------|-------------------|----------------|-----------------|
| 005 | 150-1000 | TRAFFIC CONTROL - PROJECT NO. 21-3100-21101 | LS | 1.00 | | |
| 010 | 210-0200 | GRADING PER MILE - (RESURFACING) | LM | 8.03 | | |
| 015 | 402-3113 | RECYCLED ASPH CONC 12.5 MM SUPERPAVE, GP 1 OR 2, INCL BITUM MATL & H LIME | TN | 9795.00 | | |
| 020 | 402-3121 | RECYCLED ASPH CONC 25 MM SUPERPAVE, GP 1 OR 2, INCL BITUM MATL & H LIME | TN | 0 | | |
| 025 | 413-0750 | TACK COAT | GL | 11870.00 | | |
| 030 | 415-5000 | ASPH CONC OPEN GRADED CRACK RELIEF INTERLAYER GP2 ONLY INCL BITUM | TN | 5345.00 | | |
| 035 | 429-1000 | RUMBLE STRIPS | EA | 6.00 | | |
| | | SIGNING AND MARKING | | | | |
| 040 | 652-2501 | SOLID TRAFFIC STRIPE, 5 IN, WHITE | LM | 16.06 | | |
| 045 | 652-2502 | SOLID TRAFFIC STRIPE, 5 IN, YELLOW | LM | 11.24 | | |
| 050 | 652-3502 | SKIP TRAFFIC STRIPE, 5 IN, YELLOW | GLM | 4.81 | | |
| 055 | 653-1704 | THERMOPLASTIC SOLID TRAF STRIPE, 24 IN, WHITE | LF | 160.00 | | |
| 060 | 654-1002 | RAISED PVMT. MARKERS, TP 2 | EA | 2200.00 | | |
| | | | | | TOTAL | |

COMPANY NAME: _____
 Failure to return this page may result in rejection of bid.

| | |
|-------------------------------|----------------------------|
| PUTNAM COUNTY, GEORGIA | |
| | |
| PROJECT: | PEA RIDGE ROAD RESURFACING |
| BID NUMBER: | 22-42001-001 |

CERTIFICATION OF NONCOLLUSION IN BID PREPARATION _____

(Signature)

(Date)

The County requires that all who enter into a contract for the physical performance of services with the County must satisfy O.C.G.A. § 13-10-91 and Rule 300-10-1-.02, in a manner, and such are conditions of the contract.

In compliance with the attached specifications, the undersigned offers and agrees, if this bid is accepted by the Board of Commissioners within ninety (90) days of the date of bid opening, to furnish any or all of the items upon which prices are quoted within the time specified in the bid schedule.

LEGAL BUSINESS NAME: _____

(If your company is an LLC, you must identify all principals to include address and phone numbers in your submittal)

FED TAX ID _____

ADDRESS: _____

DOES YOUR COMPANY CURRENTLY HAVE A LOCATION WITHIN COUNTY? YES NO

REPRESENTATIVE SIGNATURE: _____

PRINT AUTHORIZED REPRESENTATIVE'S NAME: _____

TELEPHONE NUMBER: _____ FAX: _____

E-MAIL ADDRESS _____

COMPANY NAME: _____

Failure to return this page my result in rejection of bid.

BID BOND

KNOW ALL MEN BY THESE PRESENTS: that

(Name of Contractor)

(Address of Contractor)

a _____
(Corporation, Partnership or Individual)

hereinafter called Principal, and

(Name of Surety)

(Address of Surety)

a Corporation of the State of _____, and a surety authorized by law to do business in the State of Georgia, hereinafter called Surety, are held and firmly bound unto

Putnam County of Board of Commissioners,
(Name of Obligee)

117 Putnam Drive, Suite A, Eatonton, Georgia 31024
(Address of Obligee)

Thereinafter referred to as Obligee: in the penal sum of _____ Dollars

(\$ _____) in lawful money of the United States, for the payment of which sum will and truly to be made, we bind ourselves, our heirs, executors, administrators and successors, jointly and severally, firmly by these presents.

WHEREAS, the Principal is about to submit, or has submitted, to Putnam County, Georgia, a proposal for furnishing materials, labor and equipment for: _____

WHEREAS, the Principal desires to file this Bond in accordance with law in lieu of a certified Bidder's check otherwise required to accompany this Bid.

NOW, THEREFORE, the conditions of this obligation are such that if the bid be accepted, the Principal shall within ten days after receipt of notification of the acceptance, execute a Contract in accordance with the Bid and upon the terms, conditions, and prices set forth in the form and manner required by Putnam County, Georgia, and execute a sufficient and satisfactory Performance Bond and Payment Bond payable to Putnam County, Georgia, each in an amount of 100% of the total Contract Price, in form and with security satisfactory to said Putnam County, Georgia, and otherwise, to be and remain in full force and virtue in law, and the Surety shall, upon failure of the Principal to comply with any or all of the foregoing requirements within the time specified above, immediately pay to Putnam County, Georgia, upon demand, the amount

hereof in good and lawful money of the United States of America, not as a penalty, but as liquidated damages.

PROVIDED, FURTHER, that Principal and Surety agree and represent that this bond is executed pursuant to and in accordance with the applicable provisions of the Official Code of Georgia Annotated, as Amended, including, but not limited to, O.C.G.A. § 36-91-1 et seq., and is intended to be and shall be constructed as a bond in compliance with the requirements thereof.

Signed, sealed, and dated this _____ day of _____ A.D., 20_____.

ATTEST:

(Principal Secretary)

(SEAL)

(Witness as to Principal)

(Address)

(Principal)

BY: _____

(Address)

(Surety)

ATTEST:

Resident or Nonresident Agent

(SEAL)

(Witness as to Surety)

(Address)

By: _____
(Attorney-in-Fact)

(Address)

NOTE: If Contractor is Partnership, all partners should execute Bond. Surety Companies executing Bonds must appear on the Treasury Department's most current list (Circular 570 as amended) and be authorized to transact business in the State where the Project is located.

CORPORATE CERTIFICATE

I, _____, certify that I am the Secretary of the Corporation named as Contractor in the foregoing bid; that _____, who signed said bid in behalf of the Contractor, was then (Title) _____ of said Corporation; that said bid was duly signed for and in behalf of said Corporation by authority of its Board of Directors, and is within the scope of its corporate powers; that said Corporation is organized under the laws of the State of _____. This _____ day of _____, 2022.

_____(Seal)

Signature

OATH OF SUCCESSFUL BIDDER

PUTNAM COUNTY, GEORGIA

Personally appeared before the undersigned officer duly authorized by law to administer oaths, _____ who, after being first duly sworn, depose and say that they are all the officers, agents, persons, or employees who have acted for or represented (Company Name) _____ in bidding or procuring a Contract with Putnam County, Georgia on the following project:

22-42001-001
PEA RIDGE ROAD RESURFACING

and that said _____ has not by (himself, themselves) or through any persons, officers, agents, or employees prevented or attempted to prevent by any means whatsoever competition in such bidding; or by any means whatsoever prevented or endeavored to prevent anyone from making a bid therefore or induced or attempted to induce another to withdraw a bid for said Work.

By: _____

Signature of Bidder

Name - Typed or Printed

Title

Sworn to and subscribed before me this

_____ day of _____, 2022

Notary Public _____

PUTNAM COUNTY BOARD OF COMMISSIONERS



117 Putnam Drive, Suite A ♦ Eatonton, GA 31024
706-485-5826 ♦ 706-923-2345 fax ♦ www.putnamcountyga.us

**Contractor Affidavit
Under O.C.G.A. § 13-10-91(b)(1)**

By executing this affidavit, the undersigned contractor verifies its compliance with O.C.G.A. § 13-10-91, stating affirmatively that the individual, firm or corporation which is engaged in the physical performance of services on behalf of the Putnam County Board of Commissioners has registered with, is authorized to use and uses the federal work authorization program commonly known as E-Verify, or any subsequent replacement program, in accordance with the applicable provisions and deadlines established in O.C.G.A. § 13-10-91. Furthermore, the undersigned contractor will continue to use the federal work authorization program throughout the contract period and the undersigned contractor will contract for physical performance of services in satisfaction of such contract only with subcontractors who present an affidavit to the contractor with the information required by O.C.G.A. § 13-10-91(b). Contractor hereby attests that its federal work authorization user identification number and date of authorization are as follows:

_____ Federal Work Authorization User Identification Number

_____ Date of Authorization

_____ Name of Contractor

_____ Name of Project

Putnam County Board of Commissioners
Name of Public Employer

I hereby declare under penalty of perjury that the foregoing is true and correct.
Executed on the _____ day of _____, 2022 in
_____ (City), _____ (State).

_____ Signature of Authorized Officer or Agent

_____ Printed Name and Title of Authorized Officer or Agent

SUBSCRIBED AND SWORN BEFORE ME ON THIS THE
_____ DAY OF _____, 20_____

_____ Notary Public Signature

My Commission Expires: _____

PUTNAM COUNTY BOARD OF COMMISSIONERS



117 Putnam Drive, Suite A ♦ Eatonton, GA 31024

706-485-5826 ♦ 706-923-2345 fax

www.putnamcountyga.us

SAVE Affidavit

(U.S. Citizens are only required to provide this affidavit one time)

By executing this affidavit under oath, as bidder to Putnam County Georgia as referenced in O.C.G.A. § 50-36-1, the undersigned applicant verifies one of the following with respect to my application for a public benefit:

Please check one box only

- 1) I am a United States citizen
- 2) I am a legal permanent resident of the United States
- 3) I am a qualified alien or non-immigrant under the Federal Immigration and Nationality Act with an alien number issued by the Department of Homeland Security or other federal immigration agency

My alien number issued by the Department of Homeland Security or other federal immigration agency is:

The undersigned applicant also hereby verifies that he or she is 18 years of age or older and has provided at least one secure and verifiable document, as required by O.C.G.A. § 50-36-1(e)(1), with this affidavit.

The secure and verifiable document provided with this affidavit can best be classified as:

In making the above representation under oath, I understand that any person who knowingly and willfully makes a false, fictitious, or fraudulent statement or representation in an affidavit shall be guilty of a violation of O.C.G.A. § 16-10-20, and face criminal penalties as allowed by such criminal statute.

Executed in _____ (city), _____ (state).

Signature of Applicant: _____

Printed Name: _____

Date _____

SUBSCRIBED AND SWORN BEFORE ME ON THIS THE _____ DAY OF _____, 20__

Notary Public Signature: _____

Affix Notary stamp/seal here

My Commission Expires: _____

REFERENCES

Putnam County requests a minimum of three (3) references where work of a **similar size and scope** has been completed **in the last three (3) years**. **DO NOT submit a project list in lieu of this form**. Attaching a list may deem the contractor's bid **non-responsive**.

1. Company Name _____

Brief Description of Project _____

Completion Date _____

Start Date _____ Contract Amount \$ _____

Contact Person _____ Telephone _____

E-Mail Address _____

2. Company Name _____

Brief Description of Project _____

Completion Date _____

Start Date _____ Contract Amount \$ _____

Contact Person _____ Telephone _____

E-Mail Address _____

3. Company Name _____

Brief Description of Project _____

Completion Date _____

Start Date _____ Contract Amount \$ _____

Contact Person _____ Telephone _____

E-Mail Address _____

Company Name _____

Note: References should be customized for each project vs. submitting the same set of references for every project bid. The references listed should be of similar size and scope of the project bidding for. Failure to return this page may result in rejection of bid.

CONTRACT DOCUMENTS

TABLE OF CONTENTS

- Contract
- Performance Bond
- Payment Bond
- Insurance Requirements
- General Conditions
- General Instructions for Bidders
- Special Provisions

SECTION II
CONTRACT

This **AGREEMENT** made and entered into this _____ day of _____, 20____ by and between Putnam County, Georgia (Party of the First Part, hereinafter called the County), and _____, (Party of the Second Part, hereinafter called the Contractor).

WITNESSETH: That the said Contractor has agreed, and by these presents does agree with the said County, for the consideration herein mentioned and under the provision of the Performance Bond and Payment Bond required by the Specifications to furnish all equipment, tools, materials, skill and labor of every description necessary to carry out and complete in a good, firm and substantial and workmanlike manner, the work specified, in strict conformity with the drawings and specifications, together with the foregoing proposal made by the Contractor, the Advertisement, the Instructions to Bidders, General Conditions, and this Agreement, shall all form essential parts to this Agreement. The work covered by this Agreement includes all work shown on plans and specifications and listed in the conditions and specifications to wit:

22-42001-001
PEA RIDGE ROAD RESURFACING

The Contractor awarded work under this contract shall commence work within ten (10) days after the issuance of the Notice to Proceed and shall fully complete all work within 60 calendar days on project 22-42001-001 Pea Ridge Road Resurfacing.

If said work is not completed within the times stated, the Contractor shall be liable and hereby agrees to pay the County as liquidated damages and not as a penalty, \$500 per calendar day for failure to complete the work in 60 calendar days, all as liquidation of the extra expense incurred by the county and liquidated damages to the county. Liquidated damages will continue until the contract is complete.

The County shall pay, and the Contractor shall receive the unit prices as stipulated in the proposal hereto attached as full compensation for everything furnished and done by the Contractor under this contract. The quantities provided in the bid form are estimates only and will vary from those indicated. Payment will be made based on actual quantities of work completed and accepted. The County reserves the right to add or delete quantities at any time. Contractor will notify the County in writing if additional items are identified or quantities of contract bid items will exceed the contract. At no time shall the contractor proceed with work outside the prescribed scope of services for which additional payment will be requested without the written authorization of the County.

When the Contractor has performed in accordance with the provisions of this Agreement, Putnam County shall pay to the Contractor, within thirty (30) days of receipt of any payment request based upon work completed or service provided pursuant to the Contract, the sum so requested, less the retainage stated in this Agreement, if any. In the event that Putnam County fails to pay the Contractor within sixty (60) days of receipt of a pay request based upon work completed or service provided pursuant to the Contract, the County shall pay the Contractor interest at the rate of 1/2% per month or pro rata fraction thereof, beginning the sixty-first (61st) day following receipt of the pay request. The Contractor's acceptance of progress payments or final payment shall release all claims for interest on said payments.

It is further mutually agreed between the Parties hereto that if, at any time after the execution of the agreement and the Performance Bond for its faithful performance and the Payment Bond, the County shall deem the surety or sureties upon such bond to be inadequate to cover the performance of the work, the Contractor shall, at its expense, within five (5) days after the receipt of notice from the County to do so, furnish an additional bond or bonds in such form and amount, and with such surety or sureties as shall be satisfactory to the first party. In such event, no further payment to the Contractor shall be deemed to be due under this agreement until such new or additional security for the faithful performance of the work shall be furnished in a manner and form satisfactory to the County.

The parties agree that each of the provisions included in this agreement is separate, distinct and severable from the other and remaining provisions of this agreement, and that the invalidity of any agreement provision shall not affect the validity of any other provision or provisions of this Contract.

(Signatures Next Page)

IN WITNESS WHEREOF, the parties hereto, acting through their duly authorized agents, have caused this **AGREEMENT** to be signed, sealed and delivered.

PUTNAM COUNTY, GEORGIA

By: _____
Billy Webster, Chairman
Putnam County Board of Commissioners

ATTEST:

Signature

Lynn Butterworth
County Clerk, Putnam County
Board of Commissioners

APPROVED AS TO FORM:

Signature
Putnam County Staff Attorney

CONTRACTOR: _____

By: _____
Signature

Print Name

Title

ATTEST:

Signature

Print Name

Corporate Secretary
(Seal)

PERFORMANCE BOND

KNOW ALL MEN BY THESE PRESENTS: that

(Name of Contractor)

(Address of Contractor)

a _____
(Corporation, Partnership or Individual)

hereinafter called Principal, and

(Name of Surety)

(Address of Surety)

a Corporation of the State of _____, and a surety authorized by law to do business in the State of Georgia, hereinafter called Surety, are held and firmly bound unto

Putnam County Board of Commissioners
(Name of Obligee)

117 Putnam Drive, Suite A, Eatonton, Georgia 31024
(Address of Obligee)

hereinafter referred to as Obligee; are held firmly bound unto said Obligee and all persons doing work or furnishing skill, tools, machinery, supplies, or material under or for the purpose of the Contract hereinafter referred to, in the penal sum of _____ Dollars

(\$ _____) in lawful money of the United States, for the payment of which sum well and truly to be made, we bind ourselves, our heirs, executors, administrators and successors, jointly and severally, firmly by these presents.

The condition of this obligation is such, as whereas the Principal entered into a certain contract, hereto attached, with the Obligee

NOW THEREFORE, the conditions of this obligation are such that if the above bound Principal shall well, truly, fully and faithfully perform said contract according to its terms, covenants, conditions, and agreements of said contract during the original term of said contract and any extensions thereof that may be granted by the obligee, with or without notice to the Surety, and during the life of any guaranty required under the contract, and shall also well and truly perform and fulfill all the undertakings, covenants, terms, conditions and agreement of any and all duly authorized modifications of said contract that may hereafter be made, then his obligation shall be void, otherwise to remain in full force and effect.

PROVIDED FURTHER, that said Surety to this Bond, for value received, hereby stipulates and agrees that no change, extension of time, alterations, or additions to the terms of the Contract or to the Work to be performed thereunder shall in any way affect its obligation on this bond, and it does hereby waive notice of any such change, extension of time, alterations, or additions to the terms of the Contract or to the work to be performed thereunder.

PROVIDED, FURTHER, that Principal and Surety agree and represent that this bond is executed pursuant to and in accordance with the applicable provisions of the Official Code of Georgia Annotated, as Amended, including, but not limited to, O.C.G.A. SS 36-91-1, et. eq., and is intended to be and shall be construed as a bond in compliance with the requirements thereof.

(Signatures Next Page)

PUTNAM COUNTY, GEORGIA

ATTEST:

(Principal Secretary)

(SEAL)

(Witness as to Principal)

(Address)

ATTEST:

Resident or Nonresident Agent

(SEAL)

(Witness as to Surety)

(Address)

(Principal)

By: _____

(Address)

(Surety)

By: _____
(Attorney-in-Fact)

(Address)

BONDING AGENT CONTACT INFO

Print Name _____

Company Name _____

E-Mail _____

Phone _____

NOTE: If Contractor is Partnership, all partners should execute Bond. Surety Companies executing Bonds must appear on the Treasury Department's most current list (Circular 570 as amended) and be authorized to transact business in the State where the Project is located.

PUTNAM COUNTY, GEORGIA

BOND # _____

PAYMENT BOND

KNOW ALL MEN BY THESE PRESENTS: that

(Name of Contractor)

(Address of Contractor)

a _____
(Corporation, Partnership or Individual)

hereinafter called Principal, and

(Name of Surety)

(Address of Surety)

a Corporation of the State of _____, and a surety authorized by law to do business in the State of Georgia, hereinafter called Surety, are held and firmly bound unto

Putnam County Board of Commissioners
(Name of Obligee)

117 Putnam Drive, Suite A, Eatonton, Georgia 31024
(Address of Obligee)

hereinafter called Obligee;

for the use and protection of all subcontractors and all persons supplying labor, services, skill, tools, machinery, materials and/or equipment in the prosecution of the work provided for in the contract hereinafter referred to in the full and just sum of _____

_____ Dollar

(\$ _____) in lawful money of the United States, for the payment of which sum, will and truly to be made, the Principal and Surety bind themselves, their, and each of their heirs, executors, administrators, successors and assigns, jointly and severally, firmly by these presents.

The condition of this obligation is such, as whereas the Principal entered into a certain contract, hereto attached, with the Obligee.

NOW, THEREFORE THE CONDITION OF THIS OBLIGATION IS SUCH, that if the Principal shall well, truly, and faithfully perform said Contract according to its terms, covenants, and conditions, and shall promptly pay all persons furnishing labor, materials services, skill, tools, machinery and/or equipment for use in the performance of said Contract, then this obligation shall be void; otherwise it shall remain in full force and effect.

PUTNAM COUNTY, GEORGIA

All persons who have furnished labor, materials, services, skill, tools, machinery and/or equipment for use in the performance of said Contract shall have a direct right of action on this Bond, provided payment has not been made in full within ninety (90) days after the last day on which labor was performed, materials, services, skill, tools, machinery, and equipment furnished, or the subcontract completed.

PROVIDED FURTHER, that said Surety to this Bond, for value received, hereby stipulates and agrees that no change, extension of time, alterations, or additions to the terms of the Contract or to the Work to be performed thereunder shall in any way affect its obligation on this bond, and it does hereby waive notice of any such change, extension of time, alterations, or additions to the terms of the Contract or to the work to be performed thereunder.

PROVIDED, HOWEVER, that no suit or action shall be commenced hereunder by any person furnishing labor, materials, services, skill, tools, machinery, and/or equipment having a direct contractual relationship with a subcontractor, but no contractual relationship express or implied with the Principal:

Unless such person shall have given notice to the Principal within ninety (90) days after such person did, or performed the last of the work or labor, or furnished the last of the materials, services, skill, tools, machinery and/or equipment for which claim is made, stating with substantial accuracy the amount claimed and the name of the party to whom the materials, services, skill, tools, machinery and/or equipment were furnished, or for whom the work or labor was done or performed. Such a notice shall be served by mailing the same by registered mail, postage prepaid, in an envelope addressed to the Principal, at any place where an office is regularly maintained for the transaction of business, or served in any manner in which legal process may be served in the State in which the aforesaid project is located, save that such service need not be made by a public officer, and a copy of such notice shall be delivered to the Obligee, to the person and at the address provided for in the Contract, within five (5) days of the mailing of the notice to the Principal.

PROVIDED, FURTHER, that any suit under this bond must be instituted before the expiration of one (1) year after the acceptance of the public works covered by the Contract by the proper authorities.

PROVIDED, FURTHER, that Principal and Surety agree and represent that this bond is executed pursuant to and in accordance with the applicable provisions of the Official Code of Georgia Annotated, as Amended, including, but not limited to, O.C.G.A. SS 36-91-1, et. eq., and is intended to be and shall be construed as a bond in compliance with the requirements thereof.

(Signatures Next Page)

PUTNAM COUNTY, GEORGIA

ATTEST:

(Principal Secretary)

(SEAL)

(Witness as to Principal)

(Address)

ATTEST:

Resident or Nonresident Agent

(SEAL)

(Witness as to Surety)

(Address)

(Principal)

By: _____

(Address)

(Surety)

By: _____
(Attorney-in-Fact)

(Address)

BONDING AGENT CONTACT INFO

Print Name _____

Company Name _____

E-Mail _____

Phone _____

NOTE: If Contractor is Partnership, all partners should execute Bond. Surety Companies executing Bonds must appear on the Treasury Department's most current list (Circular 570 as amended) and be authorized to transact business in the State where the Project is located.

PUTNAM COUNTY BOARD OF COMMISSIONERS



117 Putnam Drive, Suite A ♦ Eatonton, GA 31024

Tel: 706-485-5826 ♦ Fax: 706-923-2345 ♦ www.putnamcountyga.us

INSURANCE CLAUSE FOR ALL COUNTY CONTRACTS

The Contractor shall indemnify and hold harmless, to the fullest extent allowed by law, Putnam County, Georgia, its members, its officers and employees from and against all losses, claims, damages and expenses, including court-ordered attorney's fees, arising out of or resulting from the performance of the contract that results in bodily injury, sickness, disease, death or injury to or destruction of tangible property, including the loss of use resulting therefrom and is caused in whole or in part by the Contractor, any subcontractor, anyone directly or indirectly employed by any of them or anyone for whose acts any of them may be liable.

Contractor shall not commence work under this contract until he has obtained all insurance required under this Section and such insurance has been approved by PUTNAM COUNTY, nor shall the Contractor allow any subcontractor to commence work on his subcontract until all similar insurance required of the subcontractor has been so obtained and approved.

A. Workers' Compensation Insurance and Employer's Liability Insurance:

The Contractor shall take out and maintain during the life of this contract the applicable statutory Worker's Compensation Insurance, and in the case of any work sublet, the Contractor shall require the subcontractor similarly to provide statutory Worker's Compensation Insurance for the latter's employees. Coverage shall be provided by an insurance company authorized to write such insurance in all states where the Contractor will have employees located in the performance of this contract, and the Contractor shall require each of his subcontractors similarly to maintain Employer's Liability Insurance similarly to the Contractor.

Worker's Compensation – Required limits:

Coverage A – Coverage will include Statutory requirements

Coverage B – Employers Liability

\$100,000 Each Person

\$100,000 Each Person by Disease

\$500,000 Policy Limit – Disease

B. General Liability Insurance

1. The Contractor shall maintain during the life of this contract, Commercial General Liability Insurance, naming and protecting him and Putnam County against claims for damages resulting from (a) bodily injury, including wrongful death, and (b) property damage which may arise from operations under this contract whether such operations be by himself or by any subcontractor or anyone directly or indirectly employed by either of them. The insurance requirements are:

Commercial General Liability with limits of:
 \$1,000,000 Each Occurrence
 \$1,000,000 Personal Injury
 \$2,000,000 Products/Completed Operations
 \$2,000,000 General Aggregate

2. Coverage shall include Contractual Liability coverage insuring the contractual exposure as addressed in this contract.
3. There shall be no exclusion or limitation for the Explosion (X), Collapse (C) and Underground (U) hazards.
4. **Putnam County shall be named as Additional Insured.**
5. The Commercial General Liability coverage shall be endorsed with the Designated Construction Project(s) General Aggregate Limit endorsement.

C. Automobile Liability Insurance: The Contractor shall take out and maintain during the life of the contract such Automobile Liability Insurance as shall protect him against claims for damages resulting from (a) bodily injury, including wrongful death, and (b) property damage which may arise from the operations of any owned, hired, or non-owned automobiles used by or for him in any capacity in connection with the carrying out of this contract. The minimum acceptable limits of liability to be provided by such Automobile Liability Insurance shall be as follows:

Bodily Injury and Property Damage \$1,000,000 Combined Single Limit

D. Builder's Risk Insurance: ***(For Building Construction Contracts Only)*** Unless otherwise specified where buildings are to be constructed under this contract, the Contractor shall provide coverage for all direct physical loss (also known as "Special Causes of Loss"). Such insurance shall be written on a Replacement Cost basis covering such building in the amount equal to one-hundred percent (100%) of the contract amount (minimum) as specified herein. Losses, if any, shall be made payable to PUTNAM COUNTY and Contractor as their interest may appear. A certificate of insurance evidencing such insurance coverage shall be filed with PUTNAM COUNTY by the time work on the building begins and such insurance shall be subjected to the approval of PUTNAM COUNTY.

E. Minimum Scope of Insurance: All Liability Insurance policies shall be written on an "Occurrence" basis only. All insurance coverage is to be placed with insurers authorized to do business in the State of Georgia.

F. Certificate of Insurance: All Certificates of Insurance shall be filed with PUTNAM COUNTY on the standard ACCORD CERTIFICATE OF INSURANCE form showing the specific limits of insurance, coverage modifications and endorsements required by the preceding Sections A, B, C, D and showing PUTNAM COUNTY as an additional insured where required. Such certificate shall specifically state that insurance policies are to be endorsed to require the insurer to provide PUTNAM COUNTY thirty days notice of cancellation, non-renewal or any material reduction of insurance coverage.

The original certificate shall be provided to the Putnam County Board of Commissioners as designated and mailed to: 117 Putnam Drive, Suite A, Eatonton, GA 31024.

GENERAL CONDITIONS

Unless otherwise directed, all work performed under this contract shall be in accordance with the Georgia Department of Transportation Standard Specifications Construction of Transportation Systems, 2021 Edition, Supplemental thereto (Published and Not Published) and Special Provisions modifying them, except as noted below.

Modification of Standard Specifications

| <u>SECTION 101</u> | <u>DEFINITION AND TERMS</u> |
|-----------------------------|--|
| Section 101.14 COMMISSIONER | Delete as written and substitute the following: THE PUTNAM COUNTY BOARD OF COMMISSIONERS |
| Section 101.22 DEPARTMENT | Delete as written and substitute the following: THE PUTNAM COUNTY BOARD OF COMMISSIONERS |
| Section 101.24 ENGINEER | Delete as written and substitute the following: PUTNAM COUNTY, DIRECTOR ACTING DIRECTLY OR THROUGH HIS DULY AUTHORIZED REPRESENTATIVE. |
| Section 101.83 COUNTY | Add: THE PUTNAM COUNTY BOARD OF COMMISSIONERS |
| Section 101.84 | Add: ATLAS TECHNICAL CONSULTANTS LLC |

SECTION 102: BIDDING REQUIREMENTS AND CONDITIONS

Section 102.01 PREQUALIFICATION OF BIDDERS

Delete in its entirety and substitute the following:

Before submitting a bid in excess of \$2,000,000, the Bidder shall have been prequalified with the Georgia Department of Transportation and received a Certificate of Qualification in accordance with the Rules and Regulations approved and adopted by the State Transportation Board. Bidders submitting bids of \$2,000,000 or less shall have been registered with the Georgia Department of Transportation. In addition, the aggregate total amount a Non-prequalified Bidder may have under contract shall not exceed \$4,000,000.

Bidders intending to consistently submit Proposals shall prequalify at least once every two years. However, qualifications may be changed during that period upon the submission of additional favorable reports or upon unsatisfactory performance. In addition, the Georgia Department of

Transportation reserves the right at any time to require the Contractor to furnish a current financial and experience statement.

Bidders may be required to submit additional evidence setting forth qualifications which entitle him to considerations as a responsible Contractor. This may include:

- A complete listing of all work currently under contract and its current status
- A full listing of all work to be self-performed and to be completed by subcontractors on this project
- A listing of available equipment for use on this work, including the type, size and location of equipment
- A listing of available personnel, both supervisors and operators, for use on this project including the current projects that these personnel are assigned.

Section 102.05 EXAMINATION OF PLANS, SPECIFICATIONS, SPECIAL PROVISIONS, AND SITE OF THE WORK

Add the following paragraph:

"The County will not be responsible for Bidders' errors or misjudgment, nor for any information on local conditions or general laws and regulations."

Section 102.07 REJECTION OF PROPOSALS

Add the following subparagraphs:

"I. The County reserves the right to reject any and all bids, to waive technicalities, and to make an award as deemed in its best interest. It is understood that all bids are made subject to this Agreement, that the County reserves the right to award the bid to the lowest responsive and responsible Bidder, and in arriving at this decision, full consideration will be given to the reputation of the Bidder, his financial responsibility, and work of this type successfully completed.

J. The County also reserves the right to reject any and all bids from any person, firm, or corporation who is in arrears in any debt or obligation to the Putnam County, Georgia."

Section 102.08 PROPOSAL GUARANTY

Substitute the following for the first sentence:

"No bid will be considered unless it is accompanied by a certified check or acceptable bid bond in an amount not less than five percent (5%) of the amount bid and made payable to the Board of Commissioners of Putnam County. Such Bid Bond shall be on the forms provided by the County."

Section 102.09 DELIVERY OF PROPOSALS

Delete in its entirety and substitute the following:

"Bids should be submitted in duplicate in a sealed envelope of sufficient size with the following clearly typed or printed on the outside:

Putnam County Board of Commissioners
Bid for Construction
Bid Number
Date and Hour of Bid Opening

Company Name

SECTION 107 LEGAL REGULATIONS AND RESPONSIBILITY TO THE PUBLIC

Section 107.15 RESPONSIBILITY FOR DAMAGE CLAIMS

Delete the paragraph and substitute the following:

“The Contractor shall indemnify and save harmless the County, the engineer, and their agents and employees, from all suits, actions, or claims of any character brought because of any injuries or damage received or sustained by any person, persons, or property on account of the operations of the said Contractor; or on account of or in consequence of any neglect in safe-guarding The Work; or through use of unacceptable materials in constructing The Work; or because of any act of omission, neglect or misconduct of said Contractor; or because of any claims or amounts recovered from any infringements of patent, trademark, or copyright; or from any claims or amounts arising or recovered under the Workmen’s Compensation Act, or any other law, ordinance, order, or decree; and so much of the money due the said Contractor under and by virtue of his Contract as may be considered necessary by the County for such purpose may be withheld for the use of the County; or, in case no money is due, his surety may be held until such suit or suits, action or actions, claim or claims for injuries or damages as aforesaid shall have been settled and suitable evidence to that effect furnished to the County; except that money due the Contractor will not be withheld when the Contractor produces satisfactory evidence that he is adequately protected by public liability and property damage insurance.”

SECTION 108 - PROSECUTION AND PROGRESS

If the Contractor elects to sublet any Bid Item, no work on any such Items shall be begin without prior approval of the necessary Subcontract.

The Contractor's cost for Construction Layout shall be included in the unit price bid items.

108.02 NOTICE TO PROCEED:

Retain as written except as follows:

Delete the second paragraph which begins "Within 10 calendar days " and substitute the following:

“Within 10 calendar days after the Notice to Proceed has been issued, the Contractor shall begin the work. Contract Time charges for Available Day and Calendar Day projects will begin on the date the Contractor starts to work, or 10 days after the Notice to Proceed, whichever comes first. For Completion Date Projects Contract Time charges shall begin on the day after the Notice to Proceed.

The Engineer has the authority to suspend the Work wholly or in part, for as long as he may deem necessary, because of unsuitable weather, or other conditions considered unfavorable for continuing the Work, or for as long as he may deem necessary by reason of failure of the Contractor to carry out orders given, or to comply with any provision of the Contract. If the performance of all or any portion of the Work is suspended or delayed by the Engineer, in writing, for an unreasonable period of time (not originally anticipated, customary, or inherent to the construction industry) and the Contractor believes that additional compensation and/or contract time is due as a result of such suspension or delay, the Contractor shall submit to the Engineer, in writing, a request for adjustment

within 7 calendar days of receipt of the notice to resume work. The request shall set forth the reasons and support for such adjustment.

Upon receipt, the Engineer will evaluate the Contractor's request. If the Engineer agrees that the cost and/or time required for the performance of the Contract has increased as a result of such suspension and the suspension was caused by conditions beyond the control of, and not the fault of, the Contractor, its suppliers, or subcontractors at any approved tier, and not caused by weather, the Engineer will make an adjustment (excluding profit) and modify the Contract in writing accordingly. The Engineer will notify the Contractor of his/her determination whether or not an adjustment of the Contract is warranted.

No contract adjustment will be allowed unless the Contractor has submitted the request for adjustment within the time prescribed.

No contract adjustment will be allowed under this clause to the extent that performance would have been suspended or delayed by any other cause, or for which an adjustment is provided for or excluded under any other term or condition of this Contract.”

SECTION 109 MEASUREMENT AND PAYMENT

Section 109.07 PARTIAL PAYMENTS

Delete the second Paragraph under "A. General"

ADD the following to "A. General"

“1. The Department shall retain 5% of the gross value of the completed work as indicated by the current estimate certified by the Engineer for payment.

2. There will be no consideration for reduction of retainage until Final Payment as defined in 109.08.”

Section 109.08 FINAL PAYMENT

Delete in its entirety and substitute the following:

"Final Payment: Upon completion by the Contractor of the work, including the receipt of any final written submission of the Contractor and the approval thereof by the Department, the COUNTY will pay the Contractor a sum equal to 100 percent (100%) of the compensation set forth herein, less the total of all previous partial payments, paid or in the process of payment.

The Contractor agrees that acceptance of this final payment shall be in full and final settlement of all claims arising against the COUNTY for work done, materials furnished, costs incurred, or otherwise arising out of this Agreement and shall release the COUNTY from any and all further claims of whatever nature, whether known or unknown for and on account of said Agreement, and for any and all work done, and labor and materials furnished, in connection with same."

A. INTEREST: In the event the Contractor fails to execute the Final Supplemental Agreement as prepared by the County because he disputes the amount of the final payment as stated therein, the amount due the Contractor shall be deemed by the Contractor and the Department to be an unliquidated sum and no interest shall accrue or be payable on the sum finally determined to be due to the Contractor for any period prior to final determination of

such sum, whether such determination be by agreement of the Contractor and the Department or by final judgment of the proper court in the event of litigation between the Department and the Contractor. The Contractor specifically waives and renounces any and all rights it may have under Section 13-6-13 of the Official Code of Georgia and agrees that in the event suit is brought by the Contractor against the Department for any sum claimed by the Contractor under the Contract, for delay damages resulting from a breach of contract, for any breach of contract or for any extra or additional work, no interest shall be awarded on any sum found to be due from the Department to the Contractor in the final judgment entered in such suit. All final judgments shall draw interest at the legal rate, as specified by law. Also, the Contractor agrees that notwithstanding any provision or provisions of Chapter 11 of Title 13 of the Official Code of Georgia that the provisions of this contract control as to when and how the Contractor shall be paid for The Work. Further, the Contractor waives and renounces any and all rights it may have under Chapter 11 of Title 13 of the Official Code of Georgia.”

****ATTENTION****

FAILURE TO RETURN THE FOLLOWING DOCUMENTS MAY RESULT IN BID BEING DEEMED NON-RESPONSIVE AND AUTOMATIC REJECTION:

1. FAILURE TO USE COUNTY BID SCHEDULE.
2. FAILURE TO RETURN APPLICABLE COMPLIANCE SHEETS/SPECIFICATION SHEETS.
3. FAILURE TO RETURN APPLICABLE AGENDA.
4. FAILURE TO PROVIDE INFORMATION ON ALTERNATES OR EQUIVALENTS.
5. THE COUNTY SHALL BE THE SOLE DETERMINATION OF TECHNICALITY VS. NON-RESPONSIVE BID.
6. FAILURE TO PROVIDE BID BOND, WHEN REQUIRED, WILL RESULT IN BID BEING DEEMED NON-RESPONSIVE AND AUTOMATIC REJECTION. BID BONDS ARE NOT REQUIRED ON ALL BIDS. BOND REQUIREMENTS ARE CLEARLY STATED ON THE INVITATION TO BID. IF YOU NEED CLARIFICATION CONTACT RUSSELL SMALL AT RUSSELL.SMALL@ONEATLAS.COM

**PUTNAM COUNTY
DEPARTMENT OF COMMUNITY DEVELOPMENT
GENERAL INSTRUCTIONS FOR BIDDERS, TERMS AND CONDITIONS**

I. PREPARATION OF BIDS:

- A. Each bidder shall examine the drawings, specifications, schedule and all instructions. Failure to do so will be at the bidder's risk, as the bidder will be held accountable for their bid response.
- B. Each bidder shall furnish all information required by the bid form or document. Each bidder shall sign the bid and print or type his or her name on the schedule. The person signing the bid must initial erasures or other changes. An authorized agent of the company must sign bids.
- C. **Individuals, firms and businesses seeking an award of a Putnam County contract may not initiate or continue any verbal or written communications regarding a solicitation with any County officer, elected official, employee or other County representative without permission of the County Administrator, named in the solicitation between the date of the issuance of the solicitation and the date of the final contract award by the Board of Commissioners. Violations will be reviewed by the County Administrator. If determined that such communication has compromised the competitive process, the offer submitted by the individual, firm or business may be disqualified from consideration for award.**

II. DELIVERY:

- A. Each bidder should state time of proposed delivery of goods or services.
- B. Words such as "immediate," "as soon as possible," etc. shall not be used. The known earliest date or the minimum number of calendar days required after receipt of order (delivery A.R.O.) shall be stated (if calendar days are used, include Saturday, Sunday and holidays in the number).

III. EXPLANATION TO BIDDERS:

Any explanation desired by a bidder regarding the meaning or interpretation of the invitation for bids, drawings, specifications, etc. must be requested by the question cutoff deadline stated in the solicitation in order for a reply to reach all bidders before the close of bid. Any information given to a prospective bidder concerning an invitation for bid will be furnished to all prospective bidders as an addendum to the invitation if such information is necessary or if the lack of such information would be prejudicial to uninformed bidders. The written bid documents supersede any verbal or written communications between parties. Receipt of addendum should be acknowledged in the bid. It is the bidder's responsibility to ensure that they have all applicable addenda prior to bid submittal. This may be accomplished via contact with Mr. Russell Small, Russell.Small@oneatlas.com, prior to bid submittal.

IV. SUBMISSION OF BIDS:

- A. Bids shall be enclosed in sealed envelopes, addressed to the Putnam County Board of Commissioners with the name of the bidder, the date and hour of opening and the invitation to bid number on the face of the envelope. Telegraphic/faxed bids will not be considered. Any addenda should be enclosed in the sealed envelopes as well.
- B. Samples of items, when required, must be submitted within the time specified and, unless otherwise specified by the County, at no expense to the County. Unless otherwise specified, samples will be returned at the bidder's request and expense if items are not destroyed by testing.
- C. Items offered must meet required specifications and must be of a quality which will adequately serve the use and purpose for which intended.
- D. Full identification of each item bid upon, including brand name, model, catalog number, etc. must be furnished to identify exactly what the bidder is offering. Manufacturer's literature may be furnished.
- E. The bidder must certify that items to be furnished are new and that the quality has not deteriorated so as to impair its usefulness.
- F. Unsigned bids will not be considered except in cases where bid is enclosed with other documents which have been signed. The County will determine this.
- G. Putnam County is exempt from federal excise tax and Georgia sales tax with regard to goods and services purchased directly by Putnam County. Suppliers and contractors are responsible for federal excise tax and sales tax, including taxes for materials incorporated in county construction projects. Suppliers and contractors should contact the State of Georgia Sales Tax Division for additional information.
- H. Information submitted by a bidder in the bidding process shall be subject to disclosure after the public opening in accordance with the Georgia Open Records Act. Each page of proprietary information must be identified. Entire bid may not be deemed proprietary.

V. WITHDRAWAL OF BID DUE TO ERRORS:

The bidder shall give notice in writing of his claim of right to withdraw his bid without penalty due to an error within two (2) business days after the conclusion of the bid opening procedure. Bids may be withdrawn from consideration if the price was substantially lower than the other bids due solely to a mistake therein, provided the bid was submitted in good faith, and the mistake was a clerical mistake as opposed to a judgment mistake, and was actually due to an unintentional arithmetic error or an unintentional omission of a quantity of work, labor or material made directly in the compilation of the bid, which unintentional arithmetic error or unintentional omission can be clearly shown by objective evidence drawn from inspection of original work papers, documents and material used in the preparation of the bid sought to be withdrawn. The bidder's original work papers shall be the sole acceptable evidence of error and mistake if he elects to withdraw his bid. If a bid is withdrawn under the authority of this provision, the lowest remaining responsive bid shall be deemed to be low bid.

No bidder who is permitted to withdraw a bid shall, for compensation, supply any material or labor or perform any subcontract or other work agreement for the person or firm to whom the contract is awarded or otherwise benefit, directly or indirectly, from the performance of the project for which the withdrawn bid was submitted.

Supplier has up to forty-eight (48) hours to notify Putnam County of an obvious clerical error made in calculation of bid in order to withdraw a bid after bid opening. Withdrawal of bid for this reason must be done in writing within the forty-eight (48) hour period. Suppliers who fail to request withdrawal of bid by the required forty-eight (48) hours shall automatically forfeit bid bond. Bid may not be withdrawn otherwise.

Bid withdrawal is not automatically granted and will be allowed solely at Putnam County's discretion.

VI. TESTING AND INSPECTION:

Since tests may require several days for completion, the County reserves the right to use a portion of any supplies before the results of the tests are determined. Cost of inspections and tests of any item which fails to meet the specifications shall be borne by the bidder.

VII. F.O.B. POINT:

Unless otherwise stated in the invitation to bid and any resulting contract, or unless qualified by the bidder, items shall be shipped F.O.B. Destination. The seller shall retain title for the risk of transportation, including the filing for loss or damages. The invoice covering the items is not payable until items are delivered and the contract of carriage has been completed. Unless the F.O.B. clause states otherwise, the seller assumes transportation and related charges either by payment or allowance.

VIII. PATENT INDEMNITY:

The contractor guarantees to hold the County, its agents, officers or employees harmless from liability of any nature or kind for use of any copyrighted or uncopyrighted composition, secret process, patented or unpatented invention, articles or appliances furnished or used in the performance of the contract, for which the contractor is not the patentee, assignee or licensee.

IX. BID BONDS AND PAYMENT AND PERFORMANCE BONDS:

A five percent (5%) bid bond, a one hundred percent (100%) performance bond, and a one hundred percent (100%) payment bond shall be furnished to Putnam County for any bid as required in bid package or document. Failure to submit appropriate bonding will result in automatic rejection of bid. Bonding company must be authorized to do business in Georgia by the Georgia Insurance Commission, listed in the Department of the Treasury's publication of companies holding certificates of authority as acceptable surety on Federal bonds and as acceptable reinsuring companies, and have an A.M. Best rating as stated in the insurance requirement of the solicitation.

X. DISCOUNTS:

A. Time payment discounts will be considered in arriving at net prices and in award of bids. Offers of discounts for payment within ten (10) days following the end of the month are preferred.

- B. In connection with any discount offered, time will be computed from the date of delivery and acceptance at destination, or from the date correct invoice or voucher is received, whichever is the later date. Payment is deemed to be made for the purpose of earning the discount, on the date of the County check.

XI. AWARD:

- A. Award will be made to the lowest responsive and responsible bidder. The quality of the articles to be supplied, their conformity with the specifications, their suitability to the requirements of the County, and the delivery terms will be taken into consideration in making the award. The County may make such investigations as it deems necessary to determine the ability of the bidder to perform, and the bidder shall furnish to the County all such information and data for this purpose as the County may request. The County reserves the right to reject any bid if the evidence submitted by, or investigation of such bidder fails to satisfy the County that such bidder is properly qualified to carry out the obligations of the contract.
- B. The County reserves the right to reject or accept any or all bids and to waive technicalities, informalities and minor irregularities in bids received.
- C. The County reserves the right to make an award as deemed in its best interest, which may include awarding a bid to a single bidder or multiple bidders; or to award the whole bid, only part of the bid, or none of the bid to single or multiple bidders, based on its sole discretion of its best interest.

XII. DELIVERY FAILURES:

Failure of a contractor to deliver within the time specified or within reasonable time as interpreted by Putnam County, or failure to make replacement of rejected articles/services when so requested, immediately or as directed by the Putnam County Manager, shall constitute authority for the Putnam County Manager to purchase in the open market articles/services of comparable grade to replace the articles/services rejected or not delivered. On all such purchases, the contractor shall reimburse the County within a reasonable time specified by the Putnam County Manager for any expense incurred in excess of contract prices, or the County shall have the right to deduct such amount from monies owed the defaulting contractor. Alternatively, the County may penalize the contractor one percent (1%) per day for a period of up to ten (10) days for each day that delivery or replacement is late. Should public necessity demand it, the County reserves the right to use or consume articles delivered which are substandard in quality, subject to an adjustment in price to be determined by the Putnam County Manager.

XIII. COUNTY FURNISHED PROPERTY:

No material, labor or facilities will be furnished by the County unless so provided in the invitation to bid.

XIV. REJECTION AND WITHDRAWAL OF BIDS:

Failure to observe any of the instructions or conditions in this invitation to bid may constitute grounds for rejection of bid.

XV. CONTRACT:

Each bid is received with the understanding that the acceptance in writing by the County of the offer to furnish any or all of the commodities or services described therein shall constitute a contract between the bidder and the County which shall bind the bidder on his part to furnish and deliver the articles quoted at the prices stated in accordance with the conditions of said accepted bid. The County, on its part, may order from such contractor, except for cause beyond reasonable control, and to pay for, at the agreed prices, all articles specified and delivered.

Upon receipt of a bid package containing a Putnam County "Sample Contract" as part of the requirements, it is understood that the bidder has reviewed the documents with the understanding that Putnam County requires that all agreements between the parties must be entered into via this document. If any exceptions are taken to any part, each must be stated in detail and submitted as part of the bid. If no exceptions are stated, it is assumed that the bidder fully agrees to the provisions contained in the "Sample Contract" in its entirety.

When the contractor has performed in accordance with the provisions of this agreement, Putnam County shall pay to the contractor, within thirty (30) days of receipt of any payment request based upon work completed or service provided pursuant to the contract, the sum so requested, less the retainage stated in this agreement, if any. In the event that Putnam County fails to pay the contractor within sixty (60) days of receipt of a pay requested based upon work completed or service provided pursuant to the contract, the County shall pay the contractor interest at the rate of $\frac{1}{2}\%$ per month or pro rata fraction thereof, beginning the sixty-first (61st) day following receipt of pay requests. The contractor's acceptance of progress payments or final payment shall release all claims for interest on said payment.

XVI. NON-COLLUSION:

Bidder declares that the bid is not made in connection with any other bidder submitting a bid for the same commodity or commodities, and that the bid is bona fide and is in all respects fair and without collusion or fraud. An affidavit of non-collusion shall be executed by each bidder. Collusion and fraud in bid preparation shall be reported to the State of Georgia Attorney General and the United States Justice Department.

XVII. DEFAULT:

The contract may be canceled or annulled by the Putnam County Manager in whole or in part by written notice of default to the contractor upon non-performance or violation of contract terms. An award may be made to the next low responsive and responsible bidder, or articles specified may be purchased on the open market similar to those so terminated. In either event, the defaulting contractor (or his surety) shall be liable to the County for costs to the County in excess of the defaulted contract prices; provided, however, that the contractor shall continue the performance of this contract to the extent not terminated under the provisions of this clause. Failure of the contractor to deliver materials or services within the time stipulated on his bid, unless extended in writing by the Putnam County Manager, shall constitute contract default.

XVIII. DISPUTES:

Except as otherwise provided in the contract documents, any dispute concerning a question of fact arising under the contract which is not disposed of shall be decided after a hearing by

the Putnam County Manager, who shall reduce his/her decision to writing and mail or otherwise furnish a copy thereof to the contractor. The decision of the procurement agent shall be final and binding; however, the contractor shall have the right to appeal said decision to a court of competent jurisdiction.

XIX. SUBSTITUTIONS:

Bidders offering and quoting on substitutions or who are deviating from the attached specifications shall list such deviations on a separate sheet to be submitted with their bid. The absence of such a substitution list shall indicate that the bidder has taken no exception to the specifications contained herein.

XX. INELIGIBLE BIDDERS:

The County may choose not to accept the bid of a bidder who is in default on the payment of taxes, licenses or other monies due to the County. Failure to respond to three (3) consecutive times for any given commodity/service may result in removal from the supplier list under that commodity/service.

XXI. OCCUPATION TAX CERTIFICATE:

Each successful bidder shall provide evidence of a valid Putnam County occupation tax certificate if the bidder maintains an office within the unincorporated area of Putnam County. Incorporated, out of County, and out of State bidders are required to provide evidence of a certificate to do business in any town, County or municipality in the State of Georgia, or as otherwise required by County ordinance or resolution.

XXII. PURCHASING POLICY AND REVIEW COMMITTEE:

The Purchasing Policy and Review Committee has been established to review purchasing procedures and make recommendations for changes; resolve problems regarding the purchasing process; make recommendations for standardization of commodities, schedule buying, qualified products list, annual contracts, supplier performance (Ineligible Source List), and other problems or requirements related to Purchasing. The Purchasing Policy & Review Committee has authority to place suppliers and contractors on the Ineligible Source List for reasons listed in the Putnam County Purchasing Ordinance.

XXIII. AMERICANS WITH DISABILITIES ACT:

All contractors for Putnam County are required to comply with all applicable sections of the Americans with Disabilities Act (ADA) as an equal opportunity employer. In compliance with the Americans with Disabilities Act (ADA), Putnam County provides reasonable accommodations to permit a qualified applicant with a disability to enjoy the privileges of employment equal to those employees with disabilities. Disabled individuals must satisfy job requirements for education background, employment experience, and must be able to perform those tasks that are essential to the job with or without reasonable accommodations. Any requests for the reasonable accommodations required by individuals to fully participate in any open meeting, program or activity of Putnam County should be directed to Mr. Paul Van Haute, Putnam County Manager.

XXIV. ALTERATIONS OF SOLICITATION AND ASSOCIATED DOCUMENTS

Alterations of County documents are strictly prohibited and will result in automatic disqualification of the firm's solicitation response. If there are "exceptions" or comments to

any of the solicitation requirements or other language, then the firm may make notes to those areas, but may not materially alter any document language.

XVIII. TAX LIABILITY

Local and state governmental entities must notify contractors of their use tax liability on public works projects. Under Georgia law, private contractors are responsible for paying a use tax equal to the sales tax rate on material and equipment purchased under a governmental exemption that is incorporated into a government construction project: excluding material and equipment provided for the installation, repair, or expansion of a public water, gas or sewer system when the property is installed for general distribution purposes. To the extent the tangible personal property maintains its character (for example the installation of a kitchen stove), it remains tax-exempt. However, if the installation incorporates the tangible personal property into realty, e.g., the installation of sheetrock, it becomes taxable to the private contractor.

See O.C.G.A. 48-8-3(2) and O.C.G.A. 48-8-63

XIX. STATE LAW REGARDING WORKER VERIFICATION

Effective July 1, 2013 State Law requires that all who enter into a contract for the physical performance of services for all labor or service contract(s) that exceed \$2,499.99 (except for services performed by an individual who is licensed pursuant to Title 26, Title 43, or the State Bar of Georgia) for the County, must satisfy the Illegal Immigration Reform and Enforcement Act, in all manner, and such are conditions of the contract.

The Putnam County Manager shall be authorized to conduct random audits of a contractor's or subcontractors' compliance with the Illegal Immigration Reform and Enforcement Act and the rules and regulations of the Georgia Department of Labor. The contractor and subcontractors shall retain all documents and records of its compliance for a period of five (5) years following completion of the contract. This requirement shall apply to all contracts for all labor or service contracts that exceed \$2,499.99 except for services performed by an individual who is licensed pursuant to Title 26, Title 43, or the State Bar of Georgia.

Whenever it appears that a contractor's or subcontractor's records are not sufficient to verify the work eligibility of any individual in the employ of such contractor or subcontractor, the Putnam County Manager shall report same to the Department of Homeland Security and may result in termination of the contract if it is determined at any time during the work that the contractor/or subcontractor is no longer in compliance with the Illegal Immigration Reform and Enforcement Act.

State Law requires that all who enter into a contract for public works as defined by O.C.G.A. 36-91-2(10) for the County must satisfy the Illegal Immigration Reform and Enforcement Act of 2011, in all manner, and such are conditions of the contract.

By submitting a bid to the County, contractor agrees that, in the event the contractor employs or contracts with any subcontractor(s) in connection with the covered contract, the contractor will secure from the subcontractor(s) such subcontractor(s)' indication of the employee-number category applicable to the subcontractor, as well as attestation(s) from such

subcontractor(s) that they are in compliance with the Illegal Immigration Reform and Enforcement Act of 2011. Original signed, notarized Subcontractor Affidavits and Agreements must be submitted to the County.

The Putnam County Manager shall be authorized to conduct random audits of a contractor's or subcontractors' compliance with the Illegal Immigration Reform and Enforcement Act of 2011 and the rules and regulations of the Georgia Department of Labor. The contractor and subcontractors shall retain all documents and records of its compliance for a period of three (3) years following completion of the contract. This requirement shall apply to all contracts for the public works as defined by O.C.G.A. 36-91-2(10) where any persons are employed on the County contract.

Whenever it appears that a contractor's or subcontractor's records are not sufficient to verify the work eligibility of any individual in the employ of such contractor or subcontractor, the Putnam County Manager shall report same to the Department of Homeland Security.

A contractor's failure to participate in the federal work authorization program as defined by the Illegal Immigration Reform and Enforcement Act of 2011 shall be sanctioned by termination of the contract. If it is determined that a subcontractor is not participating in the federal work authorization program as defined by the Illegal Immigration Reform and Enforcement Act of 2011, Putnam County may direct the contractor to terminate that subcontractor. A contractor's failure to follow Putnam County's instruction to terminate a subcontractor that is not participating in the federal work authorization program as defined by the Illegal Immigration Reform and Enforcement Act of 2011 may be sanctioned by termination of the contract.

XXIX. SOLID WASTE ORDINANCE

No individual, partnership, corporation, or other entity shall engage in solid waste handling except in such a manner as to conform to and comply with the current Putnam County Solid Waste Ordinance and all other applicable local, state and federal legislation, rules, regulation and orders.

XXX. GENERAL CONTRACTORS LICENSE

Effective July 1, 2008: **All General Contractors must have a current valid license from the State Licensing Board for Residential and General Contractors, unless specifically exempted from holding such license pursuant to Georgia law (O.C.G.A. Section 43-41-17).**

XXXI. INDEMNIFICATION

To the fullest extent permitted by law, the Contractor shall, at his sole cost and expense, indemnify, defend, satisfy all judgments, and hold harmless the County, the engineer, and their agents and employees from and against all claims, damages, actions, judgments, costs, penalties, liabilities, losses and expenses, including, but not limited to, attorney's fees arising out of or resulting from the performance of the work, provided that any such claim, damage, action, judgment, cost, penalty, liability, loss or expense (1) is attributable to bodily injury, sickness, disease, or death, or to injury to or destruction of tangible property (other than the work itself) including the loss of use resulting therefrom, and (2) is caused in whole or in part by any act or omission of the Contractor, any subcontractor, anyone directly or indirectly

employed by any of them or anyone for whose acts any of them may be liable, regardless whether such claim is caused in part by a party indemnified hereunder. Such obligation shall not be construed to negate, abridge, or otherwise reduce any of the rights or obligations of indemnity which would otherwise exist as to any party or person described in this agreement. In any and all claims against the County, the engineer, or any of their agents or employees by any employee of the Contractor, any subcontractor, anyone directly or indirectly employed by any of them, or anyone for whose acts any of them may be liable, the indemnification obligation contained herein shall not be limited in any way by any limitation on the amount or type of damages, compensation, or benefits payable by or for the Contractor or any subcontractor under Worker's Compensation Acts, disability benefit acts, or other employee benefit acts.

XXXII. CODE OF ETHICS:

“Proposer/Bidder” shall disclose under oath the name of all elected officials whom it employs or who have a direct or indirect pecuniary interest in the business entity, its affiliates, or its subcontractors. The “Proposer/Bidder” shall execute a Code of Ethics affidavit. Failure to submit the affidavit during the bid or proposal process shall render the bid or proposal non-responsive.

The act of submitting false information or omitting material information shall be referred to the Purchasing Policy & Review Committee for action pursuant to the Purchasing Ordinance or to the District Attorney for possible criminal prosecution.

Any business entity holding a contract with Putnam County that subsequent to execution of the contract or issuance of the purchase order employs, subcontracts with, or transfers a direct or indirect pecuniary interest in the business entity to an elected official shall within five (5) days disclose such fact in writing under oath to the Clerk of the Board of Commissioners. Failure to comply shall be referred to the Purchasing Policy & Review Committee for action pursuant to the Purchasing Ordinance or to the District Attorney for possible criminal prosecution.

XXXIII. PENDING LITIGATION:

A bid submitted by an individual, firm or business who has litigation pending against the County, or anyone representing a firm or business in litigation against the County, not arising out of the procurement process, will be disqualified.

SPECIAL PROVISIONS AND ADDITIONS

- SECTION 150 – TRAFFIC CONTROL
- SECTION 150.6 – TRAFFIC CONTROL

**DEPARTMENT OF TRANSPORTATION
STATE OF GEORGIA**

SPECIAL PROVISION

Section 150—Traffic Control

150.1 General Description

This section, as supplemented by the Plans, Specifications, and Manual on Uniform Traffic Control Devices (MUTCD) shall be considered the Temporary Traffic Control (TTC) Plan in accordance with Work Zone Safety and Mobility Policy. Activities shall consist of furnishing, installing, maintaining, and removing necessary traffic signs, pedestrian signs, barricades, lights, signals, cones, pavement markings and other traffic control devices and shall include flagging and other means for guidance and protection of vehicular and pedestrian traffic through the Work Zone. This Work shall include both maintaining existing devices and installing additional devices as necessary in construction work zones.

The Contractor shall be responsible for the maintenance of traffic signals and Advanced Traffic Management System (ATMs) devices from the time that the system is modified until final acceptance. The maintenance of traffic signals and ATMs devices that are not a part of the Work and that are not in conflict with any portion of the Work shall not be the responsibility of the Contractor. However, the Contractor is still responsible for damages to all devices that he or his subcontractors cause, in accordance with Section 107 and other Specifications.

When any provisions of this Specification or the Plans do not meet the minimum requirements of the MUTCD, the MUTCD shall control. The 2009 Edition of the MUTCD including revisions shall be in effect for the duration of the project.

All traffic control devices used during the construction of the project shall meet the standards utilized in the MUTCD, and shall comply with the requirements of these Specifications, Georgia Construction Standards and Details, Project Plans, Design Manuals, and Special Provisions.

The needs and control of all road users (motorists, bicyclists and pedestrians within the highway right-of-way and easements, including persons with disabilities in accordance with the Americans with Disabilities Act of 1990 (ADA), Title II, Paragraph 35.130) through a Temporary Traffic Control (TTC) zone shall be an essential part of highway construction, utility work, maintenance operations and management of traffic incidents.

Utilities included in the Contract are bound by Special Provision 150 and shall follow its requirements. For utilities not included in the Contract but working within the project limits, they shall, at a minimum follow the MUTCD. Moreover, in accordance with Utility Accommodation Policy and Standards Manual dated 2016, the Engineer reserves the right to require additional certified flaggers, signs, warning lights, channelization devices, and other safety devices as may be necessary to properly protect, warn, and safeguard the traveling public. In addition, the Department reserves the right to place time restrictions or moratoriums on all utility work covered under a permit when, in the opinion of the Department, the continuance of the Work would seriously hinder traffic flow, be needlessly disruptive, or would unnecessarily inconvenience the traveling public. In case of emergencies, Utilities shall be provided access in accordance with Utility Accommodation Policy and Standards Manual.

150.1.01 Definitions

For Special Provision 150, the definitions for “shall”, “should”, and “may” will be in accordance with MUTCD (1A.13).

Shall (Standard) - a statement of required, mandatory, or specifically prohibitive practice regarding a traffic control device.

Should (Guidance) - a statement of recommended, but not mandatory, practice in typical situations, with deviations allowed if engineering judgment or engineering study indicates the deviation to be appropriate.

May (Option) - a statement of practice that is a permissive condition and carries no requirement or recommendation.

150.1.02 Content

150.1 General Description

150.1.01 Definitions

150.1.02 Content

150.1.03 Related References

A. Standard Specification

B. Reference Documents

150.1.04 Submittals/Preconstruction

A. Worksite Traffic Control Supervisor

B. Sequence of Operations

C. Pedestrian Considerations

1. Pedestrian Signage

2. Temporary Pedestrian Facilities

150.2 Materials and Traffic Control Devices

150.2.01 Traffic Control Devices

A. NCHRP 350 and MASH

B. Approval

C. Quality Guidelines for All Temporary Traffic Devices

150.2.02 Reflectorization Requirements

A. Signs

B. Channelization Devices

150.2.03 Arrow Panels

150.2.04 Channelization Devices

A. General

B. Drums

1. Design

2. Application

3. Longitudinal Channelization

4. Removal

C. Vertical Panels

- 1. Design
- 2. Application

D. Cones

- 1. Design
- 2. Applications

E. Barricades

- 1. Design
- 2. Application

F. Warning Lights

- 1. Design
- 2. Application

150.2.05 Flashing Beacon

150.2.06 Guardrail

150.2.07 Interim Signs

- A. Posts
- B. Sign Blanks and Panels

150.2.08 Pavement Markings

- A. All Traffic Striping for Forty-Five (45) Days or Less (≤ 45 Days)
- B. All Temporary Striping Beyond Forty-Five (45) days (> 45 Days)
- C. All Temporary Traffic Striping on Final Surface

150.2.09 Portable Changeable Message Signs

150.2.10 Portable Impact Attenuators

150.2.11 Portable Temporary Traffic Control Signals

150.2.12 Raised Pavement Markers

150.2.13 Rumble Strips

150.2.14 Temporary Barriers

- A. Design
- B. Application

150.2.15 Temporary Guardrail Anchorage- Type 12

150.2.16 Temporary Traffic Signal

150.3 Construction Requirements

150.3.01 General

- A. Implementation Requirements

- B. Maintenance of Traffic Control Devices
- C. Traffic Interruption Restrictions
- D. Work Zone Restrictions

- 1. Interstate
- 2. Non-Interstate Divided Highways
- 3. Non-Divided Highways

- E. Work Zone Geometric Restrictions
- F. Clear Zone
- G. Milled Surface Restrictions
- H. Construction Vehicle
- I. Environmental Impacts
- J. Existing Street Lights
- K. Nighttime Work Lighting
- L. Removal/Reinstallation of Miscellaneous Items

150.3.02 Personnel – Worker Safety Apparel

150.3.03 Signage – General

- A. Signing Requirements of the Temporary Traffic Control (TTC) Plan
- B. Conflicting or Non-Applicable Signs
- C. Removal of Existing Signs and Supports
- D. Interim Guide, Warning and Regulatory Signs
- E. Existing Special Guide Signs

- 1. Special Guide Signs
- 2. Interim Special Guide Signs
- 3. Interim Overhead Guide Sign Structures
- 4. Permanent Special Guide Signs

F. Stop Sign Regulated Intersections

G. Low Shoulder Signage

- 1. Low Shoulder for Construction/Reconstruction/Resurfacing Projects
- 2. Shoulder Drop-Off for Construction/Reconstruction/Resurfacing Project

H. Bump Signage

I. Sign Visibility

150.3.04 Advance Warning Signs

A. Project Signs - All Type of Highways

- 1. State Routes
- 2. Interstate, Limited Access and Multilane Divided Highways
- 3. Ramp Work on Limited Access Highways

B. Highway Work Zone

- 1. No Reduction in the Existing Posted Speed Limit in Highway Work Zone
- 2. Reducing the Speed Limit in a Highway Work Zone
- 3. Variable Speed Limit Zones

C. Installation/Removal of Work Area Signage

150.3.05 Shoulder/Lane Closure

A. Approval/Restrictions

1. Closure Length
2. Duration

B. Shoulder Closure

C. Lane Closure

1. Advance Warning Signs
2. Transition Area – Taper
3. Activity Area
4. Termination Area

D. Removal of Lane Closures

E. Exit and Entrance Ramps

150.3.06 Traffic Pacing Method

A. Pacing of Traffic

B. Methods of Signing for Traffic Pacing

150.3.07 Flagging Operation

A. Flaggers

B. Flagger Certification

C. Flagger Appearance and Equipment

D. Flagger Warning Signs

E. Pilot Vehicle Requirements

F. Automated Flagger Assistance Devices

G. Portable Temporary Traffic Control Signals

150.3.08 Traffic Signals

A. Responsibility/Cost

B. Law Enforcement Officer Requirement

150.3.09 Mobile Operations

150.3.10 Pavement Markings

A. General

1. Resurfacing Projects
2. Widening and Reconstruction Projects
3. New Location Construction Projects

B. Installation and Removal of Pavement Markings

1. Installation
2. Removal
3. Intermediate Surface
4. Final Surface
5. Pay Factor Reduction for Asphaltic Concrete Final Surfaces
6. Preparation and Planning for Traffic Shifts

C. Raised Pavement Markers

1. Supplementing Lane Lines
2. Supplementing Ramp Gore Lines
3. Other Lines

D. Exceptions for Interim Markings

1. Two-Lane, Two-Way Roadway
2. Multi-Lane Highway - with No Paved Shoulder(s) or Paved Shoulder(s) Four Feet or Less ($\leq 4'$)
3. Limited Access Roadways and Roadways with Paved Shoulder Greater than Four Feet ($>4'$)
4. Ramps for Multi-lane Divided Highways
5. Miscellaneous Pavement Markings

150.3.11 Differences in Elevation between Travel Lanes and Shoulders

A. Differences in Elevations

1. Difference of Two Inches ($\leq 2''$) or Less Between Adjacent Travel Lanes
2. Difference of Two Inches ($\leq 2''$) or Less Between Adjacent Travel Lane and Paved Shoulder
3. Difference of Greater Than Two Inches ($>2''$) is Permitted for Continuous Operations
4. Difference of Greater Than Two Inches ($>2''$) Between Travel Lanes and/or Shoulders for Non-Continuous Operations

B. Healed Section

C. Emergency Situations

D. Plating

E. Asphaltic Concrete Resurfacing Projects

1. Shoulder Construction Included as a Part of the Contract
2. Shoulder Construction Not Included as a Part of the Contract

150.3.12 Work Zone Law Enforcement

150.4 Measurement

150.4.01 Traffic Control Items

A. Traffic Control

B. Changeable Message Sign, Portable

C. Flashing Beacon Assembly

D. Pavement Markings

E. Portable Impact Attenuators

F. Signs

1. Interim Ground Mounted or Interim Overhead Special Guide Signs
2. Remove and Reset Existing Special Guide Signs, Ground Mount or Overhead
3. Modify Special Guide Signs, Ground Mount or Overhead

G. Temporary Audible Information Device

H. Temporary Barrier

I. Temporary Curb Cut Wheelchair Ramps

J. Temporary Guardrail Anchorage, Type 12

K. Temporary Walkways with Detectable Edging

L. Traffic Signal Installation - Temporary

M. Work Zone Law Enforcement

150.5 Reserved

150.6 Special Conditions

150.7 Payment

150.7.01 Enforcement and Adjustments

150.1.03 Related References

A. Standard Specifications

Section 104 - Scope of Work

Section 105 - -Control of Work-Legal Regulations and Responsibility to the Public

Section 107 - Legal Regulations and Responsibility to the Public

Section 108 - Prosecution and Progress

Section 209 - Subgrade Construction

Section 400 - Hot Mix Asphaltic Concrete Construction

Section 441 - Miscellaneous Concrete

Section 429 - Rumble Strips

Section 620 - Temporary Barrier

Section 632 - Portable Changeable Message Signs

Section 641 - Guardrail

Section 647 - Traffic Signal Installation

Section 648 - Traffic Impact Attenuator

Section 652 - Painting Traffic Stripe

Section 653 - Thermoplastic Traffic Stripe

Section 654 - Raised Pavement Markers

Section 656 - Removal of Pavement Markings

Section 657 - Preformed Plastic Pavement Markings

Section 658 - Polyurea Traffic Strip

Section 659 - Hot Applied Preformed Plastic Pavement Markings

Section 911 - Sign Posts

Section 912 - Sign Blanks and Panels

Section 913 - Reflectorizing Materials

B. Referenced Documents

ASTM D4956-13 (Retro-reflectivity)

American Traffic Safety Services Association (ATSSA)

Construction Detail A-3 Curb Cut (Wheelchair) Ramps Concrete Sidewalk Details

Construction Detail A-4 Detectable Warning Surface Truncated Dome Size, Spacing and Alignment Requirements

Construction Detail T-3A (Type 7, 8, and 9 Square Tube Post Installation Detail)

GDOT Signing and Marking Design Guidelines

Georgia Standard 4000W “Lengths of Advancement, Clear Zone Distances, Fill Height Embankment”

Georgia Standard 4960 “Temporary Barrier (End Treatment Options)”

Georgia Standard 9102 “Traffic Control Detail for Lane Closure on Two-Lane Highway”

Georgia Standard 9106 “Traffic Control Detail for Lane Closure on Multi-Lane Divided Highway”

Georgia Standard 9107 “Traffic Control Detail for Lane Closure on Multi-Lane Undivided Highway”

Georgia Standard 9121 “Tapers, Signs, and Markings for Passing Lanes”

Manual for Assessing Safety Hardware (MASH)

Manual on Uniform Traffic Control Devices (MUTCD)

National Cooperative Highway Research Program (NCHRP) 350

National Safety Council

Qualified Product List #29 (QPL-29) Reflective Sheeting

Qualified Product List #34 (QPL-34) Work Zone Traffic Control Devices (Drums, Type III Barricades, Vertical Panels, and Portable Sign Systems)

Qualified Product List #35 (QPL-35) Drive Type Galvanized Steel Sign Posts

Qualified Product List #46 (QPL-46) Traffic Pavement Markings

Qualified Product List #64 (QPL-64) Attenuator Units (Compression Crash Cushion) and Guardrail End Treatments

Qualified Product List #76 (QPL-76) Raised Pavement Markers and Channel Markers

Qualified Product List #79 (QPL-79) Portable Arrow Boards

Qualified Product List #82 (QPL-82) “Portable Changeable Message Signs”

Utility Accommodation Policy and Standards Manual

Work Zone Safety and Mobility Policy

150.1.04 Submittals/Preconstruction

A. Worksite Traffic Control Supervisor

The Contractor shall designate a qualified individual as the Worksite Traffic Control Supervisor (WTCS). The WTCS shall be responsible for selecting, installing and maintaining all traffic control devices in accordance with the Plans, Specifications, Special Provisions and the MUTCD. The WTCS shall be currently certified by the American Traffic Safety Services Association (ATSSA) Work Site Traffic Supervisor Certification program or the National Safety Council Certification program. On-line classes will not be accepted.

The WTCS shall be available on a twenty-four (24) hour basis to perform his duties. If the Work requires traffic control activities to be performed during the daylight and nighttime hours, it may be necessary for the Contractor to designate an alternate WTCS. An alternate WTCS must meet the same requirements and qualifications as the primary WTCS and be accepted by the Engineer prior to beginning any traffic control duties. The Worksite Traffic Control Supervisor's traffic control responsibilities shall have priority over all other assigned duties.

As the representative of the Contractor, the WTCS shall have full authority to act on behalf of the Contractor in administering the TTC Plan. The WTCS shall have appropriate training in safe traffic control practices in accordance with Part 6 of the MUTCD. In addition to the WTCS, all other individuals making decisions regarding traffic control shall meet the training requirements of the Part 6 of the MUTCD.

The Worksite Traffic Control Supervisor (WTCS) shall have a copy of Part 6 of the MUTCD and the Contract on the job site. Copies of the current MUTCD may be obtained from the FHWA web page at <http://mutcd.fhwa.dot.gov>.

The WTCS shall supervise the initial installation of traffic control devices. The Engineer, prior to the beginning of construction, will review the initial installation. Modifications to traffic control devices as required by sequence of operations or staged construction shall be reviewed by the WTCS.

Any work performed on the interstate or limited access highway right-of-way that requires traffic control shall be supervised by a submitted/approved certified Worksite Traffic Control Supervisor. No work requiring traffic control shall be performed unless the certified WTCS is on the worksite. Failure to maintain a Certified Worksite Traffic Control Supervisor on the Work will be considered as non-performance under Subsection 150.7.01.

The WTCS or alternate WTCS shall be available on a full-time basis to maintain traffic control devices with access to all personnel, materials, and equipment necessary to respond effectively to an emergency situation within forty-five (45) minutes of notification of the emergency.

The WTCS shall perform inspections, at a minimum once a month, to ensure that traffic control is maintained. For all interstate and limited access highways, the WTCS shall perform, as a minimum, weekly traffic control inspections. The inspections will start with the installation of the advance warning signs and will stop when a maintenance acceptance is issued or when the corrective list is completed.

An inspection shall include both daytime and nighttime reviews. The inspection shall be reported to the Engineer on a Traffic Control Inspection Report, (TC-1). Unless modified by the special conditions or by the Engineer, routine deficiencies shall be corrected within a twenty-four (24) hour period. Failure to comply with these provisions shall be grounds for dismissal from the duties of WTCS and/or removal of the WTCS from the project. Failure of the WTCS to execute his duties shall be considered as non-performance under Subsection 150.7.01.

TRAFFIC CONTROL INSPECTION REPORT (TC-1)

Project No.: _____ County: _____

Contractor: _____ Date: _____ Daytime: _____

Nighttime: _____

PURPOSE: To provide adequate warning, delineation, and channelization to assist in guiding road users in advance of and through the work zone by utilizing proper pavement markings, signs, and other MUTCD compliant devices.

RESPONSIBILITY: The Worksite Traffic Control Supervisor (WTCS) has the duty of ensuring that all traffic control devices are installed and maintained according to the requirements of the Traffic Control Plan.

DEFICIENCIES: Items noted below require corrective measures be performed within the next _____ hours/days.

| <u>LOCATION</u> | <u>DESCRIPTION</u> | <u>ACTION REQUIRED</u> |
|-----------------|--------------------|------------------------|
| | | |
| | | |
| | | |
| | | |

(use additional sheets if needed)

Signature: _____ WTCS or DOT performing inspection

DOT inspection presented to WTCS Date: _____ Time: _____

TO BE COMPLETED BY THE WTCS

The attached deficiencies were corrected by Date: _____ Time: _____

Signature _____ Return TC-1 to DOT inspector.

The WTCS certifies that all traffic control devices in use on the project are MASH/NCHRP 350 crashworthy compliant.

Traffic Control Checklist

Satisfactory Unsatisfactory Non-applicable

Signs

S

U

N

- Are the signs correctly installed?
- Signs are in place according to TTC Plans. Signs are plumb and level. Signs are at the proper height.
- Are the signs visible and readable to the public both daytime and nighttime?
- Is retroreflectivity good?
- Are signs not in use including PCMS properly stored?

TTC Devices

S

U

N

- Are they MASH/NHCRP 350 approved? Do they meet MUTCD and Special Provision 150 requirements?
- Are they installed according to manufacture recommendation?
- Are they in acceptable/marginal condition? Are they stable? Is the retroreflectivity good?

Clear Zone

S

U

N

- Are all material and equipment stored beyond the clear zone?
- If stored in clear zone, are they protected by positive barrier?
- Are drop-offs marked and healed according to Special Provision 150?

Positive Barriers

S

U

N

- Are the barriers in acceptable/marginal condition and FHWA approved?
- Are the barrier reflectors proper and in good condition?
- Do the barriers extend to the proper advancement length? Are the tapers according to GA Standards?

Attenuators and Guardrails

S

U

N

- Are the proper attenuator assemblies in use?
- Gating - Is the recovery area free of debris and provide the necessary recovery area?
- Is the assembly in accordance with manufacture's recommendation?
- Are the guardrails properly anchored and/or attached to the barrier?
- Are shoes and transition sections in accordance with Standards?

Pavement Markings

S

U

N

- Are the pavement markings visible and legible?
- Can they be seen during the daytime and nighttime?
- Are there no conflicting pavement markings?
- Are the pavement markings including RPM installed and maintained according to section 150?

The Engineer will periodically review the Work for compliance with the requirements of the TTC plan.

On projects where traffic control duties will not require full time WTCS supervision, the Engineer may allow the Contractor's Project superintendent, foreman, subcontractor, or other designated personnel to serve as the WTCS as long as satisfactory results are obtained. Nevertheless, the individual shall meet the requirements and perform the duties of a WTCS.

B. Sequence of Operations

Any Sequence of Operations provided in this Contract in conjunction with any staging details which may be shown in the Plans, is a suggested sequence for performing the Work. It is intended as a general staging plan for the orderly execution of the Work while minimizing the impact on pedestrian facilities, mainline, cross-streets and side streets. The Contractor shall develop detailed staging and temporary traffic control plans for performing specific areas of the Work including but not limited to all traffic shifts, detours, bridge widenings, paces, or other activities that disrupt traffic or pedestrian flow. The Engineer may require detailed staging and TTC Plans for lane closures or disruption to pedestrian facilities. These Plans shall be submitted for approval at least two (2) weeks prior to the scheduled date of the activity. Activities that have not been approved at least seven (7) days prior to the scheduled date shall be rescheduled.

Where traffic is permitted through the work area under stage construction, the Contractor may choose to construct, at no additional expense to the Department, temporary on-site bypasses or detours in order to expedite the Work. Plans for such temporary bypasses or detours shall be submitted to the Engineer for review and approval thirty (30) calendar days prior to the proposed construction. Such bypasses or detours shall be removed promptly when in the opinion of the Engineer; they are no longer necessary for the satisfactory progress of the Work. Bypasses and detours shall meet the minimum requirements of Subsection 150.3.01.E.

As an option to the Sequence of Operations in the Contract, the Contractor may submit an alternative Sequence of Operations for review and approval. Alternate Sequence of Operations for pedestrian facilities shall be in compliance with the MUTCD and ADA. Pedestrian needs identified in the preconstruction phase shall be included in the proposed alternate plan.

The Department will not pay, or in any way, reimburse the Contractor for claims arising from the Contractor's inability to perform the Work in accordance with the Sequence of Operations provided in the Contract or from an approved Contractor alternate.

The Contractor shall secure the Engineer's approval of the Contractor's proposed plan of operation, sequence of work and methods of providing for the safe passage of vehicular and pedestrian traffic before it is placed in operation. The proposed plan of operation shall supplement the approved traffic control plan. Any major changes to the approved TTC plan, proposed by the Contractor, shall be submitted to the Department for approval.

Some additional traffic control details will be required prior to any major shifts or changes in traffic. The traffic control details shall include, but not be limited to, the following:

1. A detailed drawing showing traffic locations and lanes for each step of the change.
2. The location, size, and message of all signs required by the MUTCD, Plan, Special Provisions, and other signs as required to fit conditions. Any portable changeable message signs used shall be included in the details.
3. The method to be used in, and the limits of, the obliteration of conflicting lines and markings.
4. Type, location, and extent of new lines and markings.
5. Horizontal and vertical alignment and superelevation rates for detours, including cross-section and profile grades along each edge of existing pavement.
6. Drainage details for temporary and permanent alignments.
7. Location, length, and/or spacing of channelization and protective devices (temporary barrier, guardrail, barricades, etc.)

8. Starting time, duration and date of planned change.
9. For each traffic shift, a paving plan, erection plan, or work site plan, as appropriate, detailing workforce, materials, and equipment necessary to accomplish the proposed Work. This will be the minimum resource allocation required in order to start the Work.

The above details shall be submitted to the Engineer for approval at least fourteen (14) days prior to the anticipated traffic shift. Submission should be made electronically in a portable document format (pdf). The Contractor shall have traffic control details for a traffic shift which has been approved by the Engineer prior to commencement of the physical shift. All preparatory work relative to the traffic shift, which does not interfere with traffic, shall be accomplished prior to the designated starting time. The Engineer and the Contractor's representative will verify that all conditions have been met prior to the Contractor obtaining materials for the actual traffic shift.

C. Pedestrian Considerations

All existing pedestrian facilities, including access to transit stops, shall be maintained. Where pedestrian routes are closed, alternate routes shall be provided. Closures of existing, interim and final pedestrian facilities shall have the prior written approval of the Engineer. When existing pedestrian facilities are disrupted, closed or relocated in a TTC zone, the temporary facilities shall be detectable and shall include accessibility features consistent with the features present in the existing pedestrian facility. Pedestrian facilities are considered improvements and provisions made to accommodate or encourage walking. Whenever a sidewalk is to be closed, the Engineer shall notify the maintaining agency two (2) weeks prior to the closure. Prior to closure, detectable barriers (that are detectable by a person with a visual disability traveling with the aid of a long cane), as described by the MUTCD, shall be placed across the full width of the closed sidewalk. Barriers and channelizing devices used along a temporary pedestrian route shall be in compliance with the MUTCD.

Temporary Traffic Control devices used to delineate a Temporary Traffic Control Zone Pedestrian Walkway shall be in compliance with Subsection 150.3.01.A. Appropriate signs as described in the MUTCD shall be maintained to allow safe passage of pedestrian traffic or to advise pedestrians of walkway closures (Refer to MUTCD Figures TA-28 and TA-29 for guidance). Advance closure signing should be placed at intersections rather than midblock locations so that pedestrians are not confronted with midblock work sites that will induce them to attempt skirting the work site or making a midblock crossing. Temporary Traffic Control devices and construction material shall not intrude into the usable width of the pedestrian walkway. Signs and other devices shall be placed such that they do not narrow or restrict any pedestrian passage to less than forty-eight inches ($\geq 48''$).

1. Pedestrian Signage

A pedestrian walkway shall not be severed or relocated for non-construction activities, such as parking for construction vehicles and equipment. Movement by construction vehicles and equipment across designated pedestrian walkways should be minimized. When necessary, construction activities shall be controlled by flaggers. Pedestrian walkways shall be kept free of mud, loose gravel or other debris.

When temporary covered walkways are used, they shall be lighted during nighttime hours. When temporary traffic barrier is used to separate pedestrian and vehicular traffic, the temporary barrier shall meet NCHRP-350 Test Level Three. The barrier ends shall be protected in accordance with Georgia Standard 4960. Curbing shall not be used as a substitute for temporary traffic barriers when temporary traffic barriers are required. Tape, rope or plastic chain strung between temporary traffic control devices are not considered as detectable and shall not be used as a control for pedestrian movements.

The WTCS shall inspect the activity area daily to ensure that effective pedestrian TTC is being maintained. The inspection of TTC for pedestrian traffic shall be included as part of the TC-1 report.

2. Temporary Pedestrian Facilities

Temporary pedestrian facilities shall be detectable and include accessibility features consistent with the features present in the existing pedestrian facility. The geometry, alignment and construction of the facility should meet the

applicable requirements of the “Americans with Disabilities Act Accessibility Guidelines for Buildings and Facilities (ADAAG)”.

a. Temporary Walkways with Detectable Edging

A smooth, continuous hard surface (firm, stable and slip resistant) shall be provided throughout the entire length of the temporary pedestrian facility. Compacted soils, sand, crushed stone or asphaltic pavement millings shall not be used as a surface course for walkways.

Temporary walkways shall include detectable edging as defined in the MUTCD. When temporary traffic barrier is included as a pay item in the Contract and where locations identified on the Plans for positive protection will also allow them to serve as pedestrian detectable edging, payment will be made for the temporary traffic barrier in accordance with Section 620. No payment will be made for temporary walkways with Detectable Edging where existing pavements or existing edging (that meets the requirements of MUTCD) are utilized as temporary walkways. Payment for temporary detectable edging, including approved barriers and channelizing devices, installed on existing pavements shall be included in Traffic Control-Lump Sum.

Regardless of the materials used, temporary walkways shall be constructed with sufficient thickness and durability to withstand the intended use for the duration of the construction project. If concrete or asphalt is used as the surface course for the walkway, it shall be a minimum of one and one-half inches ($\geq 1\text{-}1/2''$) thick. Temporary walkways constructed across unimproved streets and drives shall be a minimum thickness of four inches ($\geq 4''$) for concrete and three inches ($\geq 3''$) for asphalt. Joints formed in concrete sidewalks shall be in accordance with Section 441. Concrete surfaces shall have a broom finish.

If plywood is used as a walkway, it must be a minimum of three quarters of an inch ($\geq 3/4''$) thick, pressure treated and supported with pressure treated longitudinal joists spaced a maximum of sixteen inches ($\leq 16''$) on center. The plywood shall be secured to the joist with galvanized nails or galvanized deck screws. Nails and screws shall be countersunk to prevent snagging or tripping the pedestrians. A slip resistant friction course shall be applied to any plywood surface that is used as a walkway. Any slip resistant material used shall have the prior written approval of the Engineer.

The Contractor may propose alternate types of Temporary Walkways provided that the Contractor can document that the proposed walkway meets the requirements of the “Americans with Disabilities Act Accessibility Guidelines for Buildings and Facilities (ADAAG)”. Alternate types of Temporary Walkways shall have the prior written approval of the Engineer.

Temporary walkways shall be constructed and maintained so there are no abrupt changes in grade or terrain that could cause a tripping hazard or could be a barrier to wheelchair use. The Contractor shall construct and maintain the walkway to ensure that joints in the walkway have a vertical difference in elevation of no more than one quarter ($\leq 1/4''$) of an inch and that the horizontal joints have gaps no greater than one half ($\leq 1/2''$) of an inch. The grade of the temporary walkway should parallel the grade of the existing walkway or roadway and the cross slope should be no greater than two percent ($\leq 2\%$). A width of sixty inches (60”), if practical, should be provided throughout the entire length of any temporary walkway. The temporary walkway shall be a minimum width of forty eight inches (48”). When it is not possible to maintain a minimum width of sixty inches (60”) throughout the entire length of temporary walkway, a sixty inch (60”) by sixty inch (60”) passing space should be provided at least every two hundred feet (200 ft.), to allow individuals in wheelchairs to pass.

Temporary walkways shall be constructed on firm subgrade. Compact the subgrade according to Section 209. Furnish and install any needed temporary pipes prior to constructing any walkway to ensure positive drainage away from or beneath the temporary walkway. Once the walkway is no longer required, remove any temporary materials and restore the area to the original conditions or as shown in the Plans.

b. Temporary Curb Cut Wheelchair Ramps

Temporary curb cut wheelchair ramps shall be constructed in accordance with Section 441 and Construction Detail A-3 Curb Cut (Wheelchair) Ramps Concrete Sidewalk Details. Ramps shall also include a detectable warning surface in accordance with Construction Detail A-4 Detectable Warning Surface Truncated Dome Size.

Spacing and Alignment Requirements. Other types of material for the construction of the temporary curb cut wheelchair ramps, including the detectable warning surface, may be used provided the Contractor can provide documentation that the material to be used meets the requirements of the “Americans with Disabilities Act Accessibility Guidelines for Buildings and Facilities (ADAAG)”. When a wheelchair ramp is no longer required, remove the temporary materials and restore the area to existing conditions or as shown in the Plans. For the items required to restore the area to original conditions or as shown in the Plans, measures for payment shall be covered by Contract pay items. If pay items are not included in the Contract, then payment for these items shall be included in Traffic Control-Lump Sum.

c. Temporary Audible Information Device

Temporary audible information devices, when shown in the Plans, shall be installed in compliance with the “Americans with Disabilities Act Accessibility Guidelines for Buildings and Facilities (ADAAG)”. The devices shall be installed in accordance with the manufacturer’s recommendations. Prior to installation, the Contractor shall provide the Engineer with a set of manufacturer’s drawings detailing the proper installation procedures for each device. When no longer required, the devices shall remain the property of the Contractor.

150.2 Materials and Traffic Control Devices

150.2.01 Traffic Control Devices

A. NCHRP 350 and MASH

All devices shall be certified in accordance with the Manual for Assessing Safety Hardware (MASH) Test Level 3 and/or the National Cooperative Highway Research Program (NCHRP) 350 Test Level 3 as applicable unless modified by this Special Provision. In addition, temporary work zone devices, including portable barriers, manufactured after December 31, 2019, must have been successfully tested under 2016 edition of MASH requirements. Such devices manufactured on or before this date, and successfully tested under either NCHRP Report 350 or the 2009 edition of MASH, may continue to be used throughout their normal service lives.

B. Approval

All traffic control devices with applicable Qualified Products List (QPL) categories shall come from the appropriate QPL list. Products not on the QPL may be used with an approval letter from the Georgia Department of Transportation Office of Materials and Testing. If there is no applicable QPL, the Contractor shall provide proof of MASH/NCHRP 350 certification. The proof may be a letter or written statement from the manufacturer that the product is MASH/NCHRP 350 approved. Decal certifications are not proof of certification and are not required.

C. Quality Guidelines for All Temporary Traffic Devices

All traffic control devices found to be unacceptable in accordance with the current ATSSA, “Quality Guidelines for Temporary Traffic Devices and Features” regardless of total numbers shall be replaced within twenty-four (24) hours unless stated otherwise in the Specifications, in the Contract, or as directed by the Engineer.

150.2.02 Retroreflectivity Requirements

A. Signs

Reflective sheeting shall meet the requirements of Section 913 and QPL-29

All construction warning signs (black on fluorescent orange) shall meet the minimum reflectivity and color requirements of ASTM D4956 Type XI regardless of the mounting height. All other signs reflectorization shall be in accordance with the Plans, Contract, and “GDOT Signing and Marking Design Guidelines”.

B. Channelization Devices

Reflective sheeting shall meet the requirements of Section 913 and QPL-29

All channelization devices (white/ fluorescent orange and white/red) shall meet the minimum retroreflectivity requirements of ASTM D4956 Type VI.

150.2.03 Arrow Panels

Arrow panels shall meet the requirements for MUTCD (6F.61) and QPL-79.

Portable sequential arrow, sequential chevron, or flashing arrow panels shall be a minimum size of forty-eight inches (48”) high by ninety-six inches (96”) wide with not less than fifteen (15) lamps used for the arrow. The arrow shall occupy virtually the entire size of the arrow panel and shall have a minimum legibility distance of one (1) mile. The minimum legibility distance is the distance at which the arrow panel can be comprehended by an observer on a sunny day, or clear night. Arrow panels shall be equipped with automatic dimming features for use during hours of darkness. The arrow panels shall also meet the requirements for a Type C panel as shown in the MUTCD (6F.61). The sequential or flashing arrow panels shall not be used for lane closure on two-lane, two-way highways when traffic is restricted to one-lane operations in which case, appropriate signing, flaggers and when required, pilot vehicles will be deemed sufficient.

The arrow panels shall be placed on the shoulder at or near the point where the lane closing transition begins. The panels shall be mounted on a vehicle, trailer, or other suitable support. Vehicle mounted panels shall be provided with remote controls. Minimum mounting height shall be seven feet (7’) above the roadway to the bottom of the panel, except on vehicle mounted panels which should be as high as practical.

For emergency situations, arrow display panels that meet the MUTCD requirements for Type A or Type B panels may be used until Type C panels can be located and placed at the site. The use of Type A and Type B panels shall be held to the minimum length of time possible before having the Type C panel(s) in operation. The Engineer shall determine when conditions and circumstances are considered to be emergencies. The Contractor shall notify the Engineer, in writing, when any non-specification arrow display panel(s) is being used in the Work.

150.2.04 Channelization Devices

A. General

Channelization shall clearly delineate the travel way through the work zone and alert drivers and pedestrians to conditions created by work activities in or near the travel way. Channelization shall be in accordance with the Plans, Specifications, MUTCD, QPL-34, and the following requirements.

B. Drums

1. Design

Drums shall meet the minimum requirement of the MUTCD (6F.67). Drums shall have six inch (6”) wide stripes – white/fluorescent orange.

2. Application

Drums shall be used as the required channelizing device to delineate the full length of a lane closure, shift, or encroachment, except as modified by this Subsection.

3. Longitudinal Channelization

Drums shall be spaced as listed below for various roadside work conditions except as modified by Subsection 150.3.11. Spacing shall be used for situations meeting any of the conditions listed as follows:

a. FORTY FOOT (40’) SPACING MAXIMUM

- For difference in elevation exceeding two inches (> 2”).

- For heeled sections no steeper than 4:1 as shown in Subsection 150.3.11, Detail 150-H..
- b. EIGHTY FOOT (80') SPACING MAXIMUM
- For difference in elevation of two inches ($\leq 2''$) or less.
 - Flush areas where equipment or workers are within ten feet ($\leq 10'$) of the travel lane.
- c. 200 FOOT SPACING MAXIMUM: Where equipment or workers are more than ten feet ($> 10'$) from travel lane. Lateral offset clearance to be four feet (4') from the travel lane.
- For paved areas, eight feet ($> 8'$) or greater in width that are paved flush with a standard width travel lane.
 - For disturbed shoulder areas not completed to typical section that are flush to the travel lane and considered a usable shoulder.

4. Removal of Drums

Drums may be removed after shoulders are completed to typical section and grassed. Guardrail and other safety devices shall be installed and appropriate signs advising of conditions such as soft or low shoulder shall be posted before the drums are removed.

C. Vertical Panels

1. Design

All vertical panels shall meet the minimum requirements of the MUTCD (6F.66). All vertical panels shall have a minimum of 270 square inches of retroreflective area facing the traffic and be a minimum of thirty-six inches ($\geq 36''$) high. The vertical panels shall be in addition a minimum eight inches ($\geq 8''$) wide with a stripe width of six inches (6") – white/fluorescent orange.

2. Application

Vertical panels with retroreflectivity less than Type VI can only be used when traffic drums reduce the travel lane to less than ten feet ($\leq 10'$); vertical panels shall be used to restore the travel lane to ten feet ($\geq 10'$) or greater. No other application of vertical panels with retroreflectivity less than type VI will be permitted.

Vertical panels with a minimum type VI retroreflectivity and six inch (6") stripe may be used for longitudinal channelization in the activity zone where work takes place for short-term stationary lane closures and intermediate-term stationary lane closures. They can be used for lane closures lasting three (3) days and with Engineer approval up to seven (7) days. They shall not be used in the transition zone including the tapers and the tangent lengths between tapers.

D. Cones

1. Design:

All cones shall be a minimum of twenty-eight inches ($\geq 28''$) in height regardless of application and shall meet the requirements of the MUTCD (6F.64).

Retroreflectivity may be deleted from all cones.

2. Application

On interstates, cones shall be prohibited. On all other routes, cones may only be used for longitudinal channelization in the activity zone where work takes place for short-term stationary lane closures. They shall not be used in the transition zone including the tapers and the tangent lengths between tapers. The use of cones for nighttime work will not be permitted. Cones shall not be stored or allowed to be visible on the worksite during nighttime.

Cones may be used for daytime flagging operations including tapers at flagging stations.

E. Barricades

1. Design

Type 3 barricades shall meet the minimum requirements of the MUTCD (6F.68). The Contractor has the option of choosing Type 3 barricades from the QPL-34 or the Contractor may utilize generic barricades that are approved by the Federal Highway Administration (FHWA). When barricades have been specifically crash tested with signs attached, the Contractor has the responsibility to attach the signs as per the manufacturer's recommendations to ensure crashworthiness. If the barricades were not tested with the signs, crashworthy compliance may require that rigid signs be mounted separate from the Type 3 barricade.

The use of Type 1 and Type 2 barricades will not be permitted.

2. Application

Type 3 barricades shall be placed as required by the Plans, the Standards, and as directed by the Engineer.

When a barricade is placed so that it is subject to side impact from a vehicle, a drum shall be placed at the side of the barricade to add target value to the barricade.

F. Warning Lights

1. Design

All warning lights shall meet the requirements of the MUTCD (6F.83).

2. Application:

- a. Type A low-intensity flashing lights shall be used as shown in the Plans, the Standards, and as directed by the Engineer.
- b. Type C Steady-Burn lights shall be used as shown in the Plans, the Standards, and as directed by the Engineer.

150.2.05 Flashing Beacon

The flashing beacon assembly, when specified, shall be used in conjunction with construction warning signs, regulatory, or guide signs to inform traffic of special road conditions which require additional driver attention. The flashing beacon assembly shall be installed in accordance with the requirements of Section 647.

150.2.06 Guardrail

Guardrail shall comply with Section 641 Guardrail and the guardrail standards.

When the removal and installation of guardrail is required, as a part of the Work, the following time restrictions shall apply unless modified by the special conditions:

From the time that the existing guardrail or temporary positive barrier protection is removed, the Contractor has fourteen (14) days to install the new guardrail and anchors. During the interim, the location without guardrail shall be protected with drums spaced at a maximum spacing of twenty feet (20'). The guardrail blunt end is to be treated as a fixed object and shall be protected. The maximum length of rail that can be removed at any time without being replaced with positive barrier protection is a total of 2000 linear feet of existing rail or the total length of one run of existing rail, whichever is less. Based on existing field conditions, the Engineer may review the Work and require that the guardrail be installed earlier than the maximum time allowed.

The Contractor shall install new guardrail, such that traffic exposure to fixed objects is minimized. Within the same workday, temporary attenuators, as defined in Subsection 150.2.10, should be installed on the approach to fixed objects that can't be protected with guardrail. Truck mounted attenuators may be used to shield exposed fixed objects for periods not to exceed fourteen (14) days. No separate payment will be made for truck mounted attenuators, attenuators, or other methods unless provided for in the Contract.

When the roadway is open to traffic, guardrail panels shall be lapped to comply with the directional flow of traffic. Should the staging of the Work require that the lap of the guardrail be changed, this Work shall be completed before the roadway is opened to traffic. The Work to change the lap of any guardrail shall be included in Traffic Control-Lump Sum.

The laps on anchors shall be in accordance with the manufacturer's recommendations and installation instructions. As a result, a trailing anchor may be lapped opposing the flow of traffic.

Failure to comply with the above time and quantity restrictions shall be considered as non-compliance under Subsection 150.7.01.

150.2.07 Interim Signs

A. Posts

Permanent mounting height to the bottom of sign shall be seven (7) feet to eight (8) feet measured vertically from the bottom of the sign to the elevation of the near edge of the pavement or from the walkway. Posts for all interim signs should be square tubular post meeting the requirements of Section 911, QPL-35, and Construction Detail T-3A (Type 7, 8, and 9 Square Tube Post Installation Detail). Ground mounted sign(s) that are 48" wide or greater shall be mounted on two posts. For barrier mounted sign, single post mount is allowed. The post(s) shall not extend beyond the top of the sign(s). The sign(s) shall be substantially plumbed and leveled.

Unprotected interim posts shall be spliced as shown in Detail 150-A, unless full length unspliced posts are used.

Unprotected post splices will not be permitted any higher than four inches above the ground line to lessen the possibility of affecting the undercarriage of a vehicle. Installation of posts may require establishment of openings in existing pavements, islands, shoulders, etc.

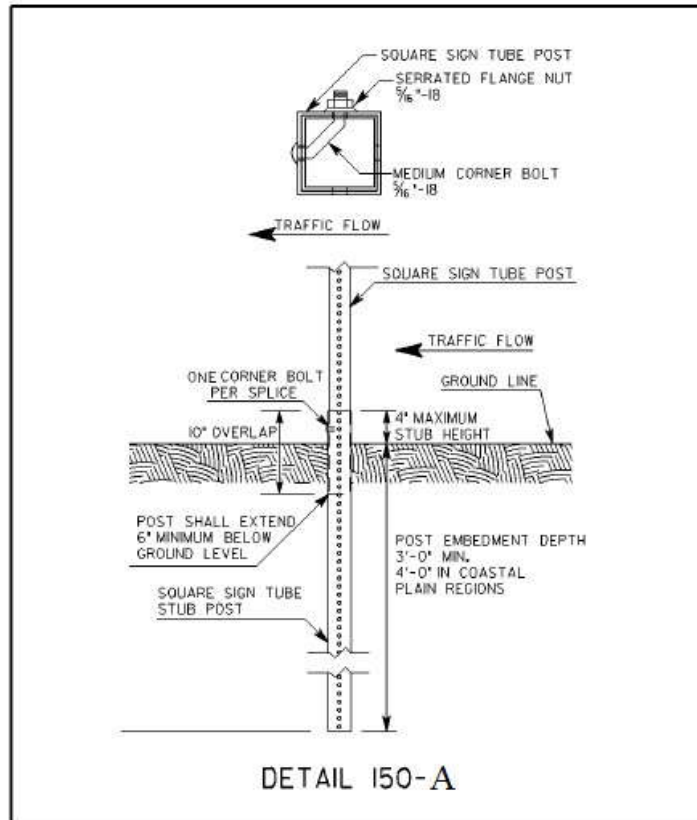

B. Sign Blanks and Panels

All TTC sign blanks and panels should conform to Section 912 of the Specifications. Alternative sign blank materials (composites, polycarbonates, fiberglass reinforced plastics, recycled plastics, etc.) shall have a letter of approval from the Office of Materials and Testing for use as interim construction signs before these materials are allowed to be incorporated into the Work, unless these rigid sign blanks are currently approved as a crashworthy sign blank material under QPL- 34. Unless specified elsewhere in the Contract, Specifications, Plans, and/or directed by the Engineer, sign sizes are according to the following:

1. All construction signs sizes shall follow the dimensions provided in the MUTCD Table 6F-1 “Temporary Traffic Control Zone Sign and Plaque Sizes” under the column for “Freeway or Expressway”.
2. For all other signs used just for staging, the sign sizes shall follow the dimensions provided in the MUTCD Table 2B-1 “Regulatory Sign and Plaque Sizes” for the largest size.
3. Permanent signs used for staging shall be according to Plans.

Plywood blanks or panels will not be permitted.

The use of flexible signs will not be permitted.

For utility work not included in the Contract, the utility Contractor may use flexible signs within the project limits.

150.2.08 Pavement Markings

All temporary traffic striping shall conform to the applicable requirements of Section 652, Section 653, Section 657, Section 658, Section 659, and QPL-46.

A. All Traffic Striping for 45 Days or Less (≤ 45 Days)

All traffic striping that will be in place for 45 days or less shall be 4 inches or greater in width.

B. All Temporary Striping Beyond 45 days (> 45 Days)

All traffic striping applied on intermediate surfaces shall be a minimum 5 inches in width or as shown on the Plans. On final surfaces when temporary striping will be overlaid or eradicated, the temporary striping shall be a minimum 5 inches in width.

C. All Temporary Traffic Striping on Final Surface

All temporary traffic striping applied to final surfaces which will not be overlaid or grinded may be 4 inches in width or as shown on the Plans.

150.2.09 Portable Changeable Message Signs

When specified, a portable changeable message sign (PCMS) shall meet the minimum requirements of Section 632, MUTCD (6F.60) and be on QPL-82. The maximum amount of messages allowed to be flashed on one PCMS is two phases (flashes). The language and the timing of the messages shall comply with the MUTCD and Section 632. When used as an advanced device, the PCMS should typically be placed ahead of the construction activities. If the PCMS is used as a substitute for another device, then the requirements for the other device apply.

Any PCMS in use, which is not protected by positive barrier protection, shall be delineated by a minimum of three drums that meet the requirement of Subsection 150.2.04.B. The drum spacing shall not exceed a maximum of ten (10') feet as shown in Detail 150-B. When the PCMS is within twenty (20') feet of the opposing traffic flow, the trailing end of the PCMS shall be delineated with a minimum of three drums spaced in the same manner as the approach side of the PCMS.

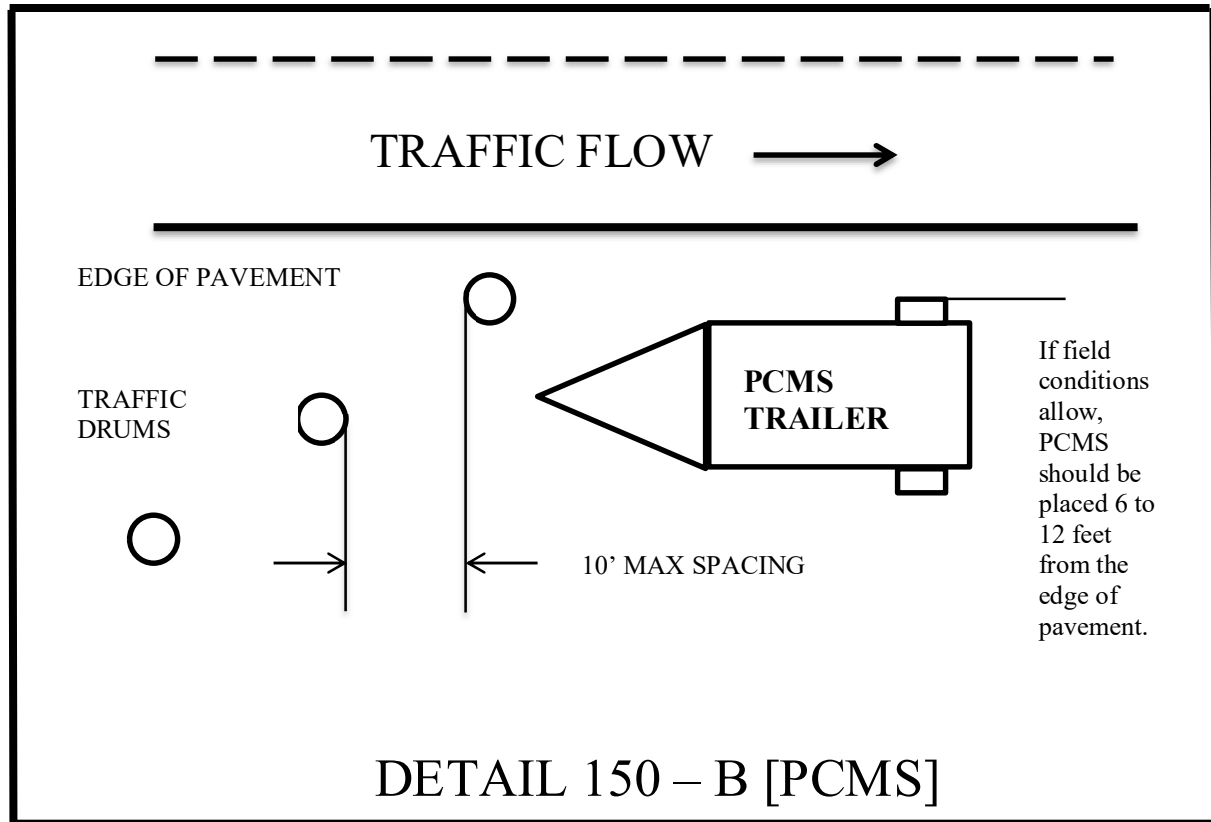

When not in use, the PCMS shall be removed from the roadway, unless protected by positive barrier protection. If the PCMS is protected by positive barrier protection, the sign panel shall be turned away from traffic when not in use.

150.2.10 Portable Impact Attenuators

This work consists of the furnishing (including spare parts), installation, maintenance, relocation, reuse as required, and removal of Portable Impact Attenuator Units/Arrays.

Portable Impact Attenuator Unit/Arrays installation shall conform to the requirements of Section 648, Manufacturer's recommendations and "(Georgia Standard 4960 "Temporary Barrier (End Treatment Options)")" and shall be installed at locations designated by the Engineer, and/or as shown on the Plans. When gating attenuators are used, the Contractor shall maintain the appropriate recovery area in accordance with the manufacturers' recommendations.

Generic sand/water loaded modules are prohibited. Manufacturers' sand/water loaded modules with specific arrays that have been NCHRP 350/MASH approved can be used in appropriate locations.

The test level of protection provided shall equal or exceed the speed limit. Test level 3 shall be used for forty-five (45) mph or above.

150.2.11 Portable Temporary Traffic Control Signals

The use of Portable Temporary Traffic Control Signals shall meet the following minimum requirements:

Only two-lane, two-way roadways will be allowed to utilize Portable Temporary Traffic Control Signals.

All portable traffic control signals shall meet the physical display and operational requirements of conventional traffic signals described in the MUTCD.

Each signal face shall have at least three lenses. The lenses shall be red, yellow, and green in color and shall give a circular type of indication. All lenses shall be twelve (12”) inches nominal in diameter. A minimum of two signal faces shall face each direction of traffic. A minimum of one signal head shall be suspended over the roadway travel lane in a manner that will allow the bottom of the signal head housing to be not less than seventeen (17’) feet above and not more than nineteen (19’) feet above the pavement grade at the center of the travel lane. The second signal head may be located over the travel lane with the same height requirements or the second signal head may be located on the shoulder. When the signal head is located on the shoulder, the bottom of the signal head housing shall be at least eight (8’) feet but not more than (15’) feet above the pavement grade at the center of highway.

Advance warning signage and appropriate pavement markings shall be installed as part of the temporary signal operation.

The signals shall be operated in a manner consistent with traffic requirements. The signals may be operated in timed-mode or in a vehicle-actuated mode. The signals shall be interconnected in a manner to ensure that conflicting movements cannot occur. To ensure that the appropriate operating pattern, including timing is displayed to the traveling public, regular inspections, including the use of accurate timing devices shall be made by the WTCS. If, at any time, any part of the system fails to operate within these requirements then the use of the signal shall be suspended, and the appropriate flagging operation shall begin immediately.

The (WTCS) shall continuously monitor the portable traffic control signal to ensure compliance with the requirements for maintenance under the MUTCD. The signal shall be maintained in a manner consistent with the intention of the MUTCD, with emphasis on cleaning of the optical system. Timing changes shall be made only by the WTCS. The WTCS shall keep a written record of all timing changes.

The portable temporary traffic signal shall have two power sources and shall be capable of running for seven calendar days continuously.

The Contractor shall have an alternate temporary traffic control plan in the event of failure of the signal.

150.2.12 Raised Pavement Markers

Raised pavement markers (RPMs) shall meet the requirements of Section 654 and QPL-76.

150.2.13 Rumble Strips

Rumble strips incorporated into the Work shall meet the requirements of Section 429 and the MUTCD. Existing rumble strips that are positioned in the traveled way to warn traffic of a stop condition shall be reinstalled prior to opening to traffic. Based on the following requirements:

Intermediate surfaces that will be in use for more than forty-five (45) calendar days shall have rumble strips reinstalled on the traveled way in the area of a stop condition. Non-refundable deductions in accordance with Subsection 150.7.01 will be assessed for any intermediate surface in place for greater than 45 days without rumble strips.

Rumble strips shall be installed on the final surface within fourteen (14) calendar days of the placement of the final surface in the area of the stop condition. Failure to install within fourteen (14) calendar days will result in assessment of non-refundable deductions in accordance with Subsection 150.7.01.

Prior to the removal of any rumble strips located in the travel lane, stop ahead (W3-1) warning signs shall be double indicated ahead of the stop condition. These warning signs shall be a minimum of 48 inches by 48 inches. These warning signs shall remain in place until the rumble strips have been reinstalled on the traveled way. Any existing warning signs for the stop ahead condition shall be removed or covered while the 48” X 48” (W3-1) signs are in place. When the rumble strips have been reinstalled, these warning signs should be promptly removed and any existing signage placed back in service.

150.2.14 Temporary Barriers

A. Design:

Temporary barriers shall meet the requirements of Sections 620. The lengths of advancement should be in accordance with Georgia Standard 4000W “Lengths of Advancement, Clear Zone Distances, and Fill Height Embankment”. The

approach end of the taper should have 10:1 or flatter ground slope. Temporary barriers shall not be used as a channelization device. Their use is in accordance with MUTCD (6F.85).

B. Application:

Temporary barriers shall be placed as required by the Plans, Standards, and as directed by the Engineer. When Temporary barrier is located twenty feet ($\leq 20'$) or less from a travel lane, yellow reflectors shall be fixed to the top of the barrier at intervals not greater than forty feet ($\leq 40'$) in the longitudinal section and twenty feet ($20'$) in the taper section and shall be mounted approximately two inches ($2''$) above the barrier. If both lanes of a two-lane two-way roadway are within twenty feet ($\leq 20'$) or less of the barrier then the reflectors shall be installed for both directions of traffic.

The reflectors shall be one hundred (100) square inches (ASTM Type VII or VIII/ Type XI) reflective sheeting mounted on flat-sheet blanks. The reflectors shall be mounted approximately two inches above the top of the barrier. The reflectors shall be attached to the barrier with adhesive or by a drilled-in anchor type device. The reflectors shall not be attached to a post or board that is placed between the gaps in the barrier sections.

Approach end of Temporary barrier shall be protected according to Georgia Standard 4960 "Temporary Barrier (End Treatment Options)" or by a portable impact attenuator.

On interstates or other controlled access highways where lane shifts or crossovers cause opposing traffic to be separated by less than forty feet ($<40'$), portable barrier should be used as a separator.

150.2.15 Temporary Guardrail Anchorage- Type 12

This work consists of the furnishing, installation, maintenance and removal of Temporary Guardrail Anchorage- Type 12 used for Portable Barrier or temporary guardrail end treatment. Materials used in the Temporary Guardrail Anchorage- Type 12 shall meet the requirements of Section 641 of the Specifications and current Georgia Standards and may be new or used. Materials salvaged from the Project, which meet the requirements of Standards, may be utilized if available. The use of any salvaged materials will require prior approval of the Engineer.

Installation of the Temporary Guardrail Anchorage- Type 12 shall conform to the requirements of the Plans, current Georgia Standards and Section 641 of the Specifications. Installation shall also include sufficient additional guardrail and appurtenances to effect the transition and connection to Temporary Concrete Barrier as required by the details in Georgia Standard 4960 "Temporary Barrier (End Treatment Options)".

150.2.16 Temporary Traffic Signals

Temporary traffic signals shall meet the requirements of Section 647 and the MUTCD.

150.3 Construction Requirements

150.3.01 General

A. Implementation Requirements

No work shall be started on any project phase until the appropriate traffic control devices have been placed in accordance with the Project requirements. Changes to traffic flow shall not commence unless all labor, materials, and equipment necessary to make the changes are available on the Project.

When any shift or change is made to the location of traffic or to the flow patterns of traffic, including pedestrian traffic, the permanent safety features shall be installed and fully operational before making the change. If staging or site conditions prevent the installation of permanent features, then the equivalent interim devices shall be utilized. This work shall also include any necessary removal and reinstallation of guardrail panels to achieve the required panel lap to accommodate the appropriate shift and traffic flow including the final traffic flow configuration. The cost of performing this work shall be included in Traffic Control-Lump Sum.

Any section of the Work that is on a new location shall have all permanent safety features installed and fully operational before the Work is opened to traffic. Safety features shall include, but are not limited to the following items:

Guardrails including anchors and delineation with properly lapped panels

- 1) Cable Barrier
- 2) Impact attenuators
- 3) Traffic signals
- 4) Warning devices
- 5) Pavement markings including words, symbols, stop bars, and crosswalks
- 6) Roadway signs including regulatory, warning, and guide

Outdoor lighting shall be considered as a safety feature for welcome centers, rest areas, and weigh station projects. For typical roadway type projects, new street lighting is not considered a safety feature, unless specifically noted in the Plans or in the special conditions.

B. Maintenance of Traffic Control Devices

Traffic control devices shall be in acceptable condition when first erected on the Project and shall be maintained in accordance with Section 104 throughout the construction period. All unacceptable traffic control devices shall be replaced within twenty-four (24) hours. When not in use, all traffic control devices shall be removed, placed or covered so as not to be visible to traffic. All construction warning signs shall be removed within seven (7) calendar days after time charges are stopped or pay items are complete. If traffic control devices are left in place for more than ten (10) calendar days after completion of the Work, the Department shall have the right to remove such devices, claim possession thereof, and deduct the cost of such removal from any monies due, or which may become due, from the Contractor.

C. Traffic Interruption Restrictions

The Department reserves the right to restrict construction operations when, in the opinion of the Engineer, the continuance of the Work would seriously hinder traffic flow, be needlessly disruptive or unnecessarily inconvenience the traveling public. The Contractor shall suspend and/or reschedule any work when the Engineer deems that conditions are unfavorable for continuing the Work.

Advanced notification requirements to the Contractor to suspend work will be according to the events and the time restrictions outlined below:

Incident management - No advanced notice required

Threatening/Inclement weather - twenty-four (24) hours

Holiday, sporting events, unfavorable conditions - Three (3) calendar days

If the Work is suspended, the Contractor may submit a request for additional Contract time as allowed under Section 108. The Department will review the request and may grant additional Contract time as justified by the impact to the Contractor's schedule. Compensation for loss of productivity, rescheduling of crews, rental of equipment or delays to the Contractor's schedule will not be considered for payment. Additional Contract time will be the only consideration granted to the Contractor.

D. Work Zone Restrictions

1. Interstate

The Contractor should not simultaneously perform work on both the inside shoulder and outside shoulder on either direction of traffic flow when the Work is within 12 feet of the travel-way. Shoulders can be alternated if areas are separated by at least one-half mile of distance.

2. Non-Interstate Divided Highways

The Contractor should not simultaneously perform work on both the inside shoulder and outside shoulder on either direction of traffic flow when the Work is within 12 feet of the travel-way. Shoulders can be alternated if areas are separated by at least one-half mile distance in rural areas or at least 500 feet of distance in urban areas.

3. Non-Divided Highways

- a. The Contractor should not simultaneously perform work on opposite sides of the roadway when the Work is within 12 feet of the travel-way. Shoulders can be alternated if areas are separated by at least one-half mile of distance in rural areas or at least 500 feet of distance in urban areas.
- b. On two-lane projects where full width sections of the existing subgrade, base or surfacing are to be removed, and new base, subgrade, or surfacing are to be constructed, the Contractor should maintain one-lane of traffic through the construction area by removing and replacing the undesirable material for half the width of the existing roadway at a time. Replacement should be made such that paving is completed to the level of the existing pavement in the adjacent lane by the end of the workday or before opening all the roadway to traffic.

E. Work Zone Geometric Restrictions

There should be no reduction in the total number of available traffic lanes including turning lanes that existed prior to construction, except as specifically allowed by the Contract and as approved by the Engineer.

Travel lane Clearances: All portions of the Work should maintain the following minimum requirements:

Horizontal: The combined dimensions of the paved shoulder and the roadway surface remaining outside the Work Zone should be no less than sixteen feet ($\geq 16'$) in width at any location.

Vertical: The overhead clearance should not be reduced to less than fifteen feet ($\geq 15'$) at any location.

The restrictions above apply to all shifts, lane closures, on-site detours and off-site detours whether shown in the Contract or proposed by the Contractor. It shall be the responsibility of the Contractor to verify that these minimum requirements have been met before proceeding with any phase of the Work. Two-lane, two-way roadways may have temporary horizontal restrictions of less than sixteen feet ($\geq 16'$) during flagging operations. The minimum horizontal clearance should be restored before the flagging operation is removed.

F. Clear Zone

At the end of the workday, all equipment, materials, and TTC devices not in use should be moved out of the clear zone or behind positive protection. The clear zone is defined by Georgia Standard 4000W "Lengths of Advancement, Clear Zone Distances, Fill Height Embankment". For urban roadway with curb, the minimum set back is six (6') feet from the curb face. If stored behind positive protection, proper lengths of advancement should be maintained. If stored behind guardrail the items shall be a minimum five feet ($\geq 5'$) from the face of the guardrail and not in the recovery zone of the anchor.

The WTCS shall monitor the Work to ensure that all the rocks, boulders, construction debris, stockpiled materials, equipment, tools and other potential hazards are kept clear of the travel lane.

G. Milled Surface Restrictions

Unless modified by the special conditions, a milled surface on any asphaltic concrete surface shall not be allowed to remain open to traffic for a period of time that exceeds thirty (> 30) calendar days.

H. Construction Vehicles

The Contractor's vehicles shall travel in the direction of normal roadway traffic and shall not reverse direction except at intersections, interchanges, or approved temporary crossings. The Contractor may submit a plan requesting that construction traffic be allowed to travel in the opposite direction of normal traffic when it would be desirable to modify traffic patterns to accommodate specific construction activities.

Prior approval of the Engineer shall be obtained before any construction traffic is allowed to travel in a reverse direction. If the Contractor's submittal is approved, the construction traffic shall be separated from normal traffic by appropriate traffic control devices.

The parking of Contractor's and/or workers' personal vehicles within the work area or adjacent to traffic is prohibited. It shall be the responsibility of the WTCS to ensure that any vehicle present at the worksite is necessary for the completion of the Work.

I. Environmental Impacts

The Contractor shall ensure that dust, mud, and other debris from construction activities do not interfere with normal traffic operations or adjacent properties.

J. Existing Street Lights

Existing street lighting shall remain lighted as long as practical and until removal is approved by the Engineer.

K. Nighttime Work Lighting

Adequate temporary lighting shall be provided at all nighttime work sites where workers will be immediately adjacent to traffic.

L. Removal/Reinstallation of Miscellaneous Items

In the prosecution of the Work, if it becomes necessary to remove any existing signs, markers, guardrail, etc. not covered by specific pay item, they shall be removed, stored and reinstalled, when directed by the Engineer, to line and grade, and in the same condition as when removed.

150.3.02 Personnel – Worker Safety Apparel

In accordance with MUTCD (6D.03) all workers, within the right-of-way who are exposed either to traffic or to work vehicles and construction equipment within the TTC zone, shall wear high-visibility safety apparel that meets the Performance Class 2 or better.

150.3.03 Signage - General

A. Signing Requirements of the Temporary Traffic Control (TTC) Plan

When existing regulatory, warning or guide signs are required for proper traffic and pedestrian control, the Contractor shall maintain these signs in accordance with the TTC plan. The Contractor shall review the status of all existing signs, interim signs added to the Work, and permanent sign installations that are part of the work to eliminate any conflicting or non-applicable signage in the TTC Plan. The Contractor's review of all signs in the TTC Plan shall establish compliance with the requirements of the MUTCD and Section 150. Any conflicts shall be reported to the Engineer immediately and the WTCS shall take the necessary measures to eliminate the conflict.

The Contractor shall make every effort to eliminate the use of interim signs as soon as the Work allows for the installation of permanent signs.

All existing illuminated signs shall remain lighted and be maintained by the Contractor.

Existing street name signs shall be maintained at street intersections.

Refer to section 150.2.05.B. **Sign Blanks and Panels** for size and material requirements.

B. Conflicting or Non-Applicable Signs

Any sign(s) or portions of a sign(s) that are not applicable to the TTC plan shall be covered so as not to be visible to traffic or shall be removed from the roadway when not in use. The WTCS shall review all traffic shifts and changes in the traffic

patterns to ensure that all conflicting signs have been removed. The review shall confirm that the highest priority signs have been installed and that signs of lesser significance are not interfering with the visibility of the high priority signs. High priority signs include signs for road closures, shifts, detours, lane closures and curves. Any signs, such as speed zones and speed limits, passing zones, littering fines and litter pick up, that reference activities that are not applicable due to the presence of the Work shall be removed, stored and reinstalled when the Work is completed.

Failure to promptly eliminate conflicting or non-applicable signs shall be considered as non-performance under Subsection 150.7.01.

C. Removal of Existing Signs and Supports

The Contractor shall not remove any existing signs and supports without prior approval from the Engineer. All existing signs and supports which are to be removed shall be stored and protected if this material will be required later in the Work as part of the TTC plan. If the signs are not to be utilized in the Work, then the signs will become the property of the Contractor unless otherwise specified in the Contract documents.

D. Interim Guide, Warning and Regulatory Signs

Interim guide, warning, or regulatory signs required to direct traffic and pedestrians shall be furnished, installed, reused, and maintained by the Contractor in accordance with the MUTCD, the Plans, Special Provisions, Special Conditions, or as directed by the Engineer. These signs shall remain the property of the Contractor. When the signs are used for long-term stationary operations as defined MUTCD (6G.02), the bottom of all interim signs shall be mounted seven feet (7') to eight feet (8') above the level of the pavement edge or sidewalk. The signs offset should be six feet (6') to twelve feet (12') from the pavement edge or two feet ($\geq 2'$) minimum for sidewalks according to MUTCD (6F-1). Special Conditions under Subsection 150.6 may modify this requirement.

Portable signs may be used when the duration of the Work is less than three (3) days or as allowed by the special conditions in Subsection 150.6. Portable interim signs shall be mounted a minimum of one foot ($\leq 1'$) above the level of the pavement edge for directional traffic of two (2) lanes or less and at seven feet (7') for directional traffic of three (3) or more lanes according to MUTCD (6F-2). Signs shall be mounted at the height recommended by the manufacturer's crashworthy testing requirements.

All sign blanks shall be rigid whether the sign is mounted as a portable sign, on a Type III barricade or as a permanent mount height sign. Utilities and their subcontractors working in the project limits, and not included in the project Contract, may use non-rigid signs.

E. Existing Special Guide Signs

Existing special guide signs on the Project shall be maintained until conditions require a change in location or legend content. When change is required, existing signs shall be modified and continued in use if the required modification can be made within existing sign borders using design requirements (legend, letter size, spacing, border, etc.) equal to that of the existing signs, or of Subsection 150.3.E.2. Differing legend designs shall not be mixed in the same sign.

1. Special Guide Signs

Special guide signs are those expressway or freeway guide signs that are designed with message content (legend) that applies to a particular roadway location. When an existing special guide sign is in conflict with work to be performed, the Contractor shall remove the conflicting sign and reset it in a new, non-conflicting location which has been approved by the Engineer.

2. Interim Special Guide Signs

When it is not possible to utilize existing signs, either in place or relocated, the Contractor shall furnish, erect, maintain, modify, relocate, and remove new interim special guide signs in accordance with the Plans or as directed by the Engineer. Interim special guide signs that may be required in addition to, or a replacement for, existing expressway and freeway (interstate) signs shall be designed and fabricated in compliance with the minimum requirements for guide signing contained in Part 2E "Guide Signs – Freeway and Expressway" of the MUTCD. All interstate shields on these signs shall be 48 inches and 60 inches for two-numeral and three-numeral routes, respectively.

The road name of the exit or route shield shall be placed on the exit gore sign.

3. Interim Overhead Guide Sign Structures

Interim overhead special guide sign structures are not required to be lighted unless specifically required by the Plans. If lighting is required, the sign shall be lighted as soon as erected and shall remain lighted, during the hours of darkness, until the interim sign is no longer required. The Contractor shall notify the Power Company at least thirty (30) days prior to desire connection to the power source.

4. Permanent Special Guide Signs

The installation of new permanent special guide signs and the permanent modification or resetting of existing special guide signs, when included in the Contract, shall be accomplished as soon as practical to minimize the use of interim special guide signs. If lighting is required by the Plans, all new permanent overhead special guide signs shall be lighted as soon as erected.

F. Stop Sign Regulated Intersections

For intersections that utilize stop sign(s) to control the flow of traffic and to restrict the movement of vehicles, the stop sign(s) shall be maintained for the duration of the Work or until such time that the stop condition is eliminated or until an interim or permanent traffic signal can be installed to provide proper traffic control. The traffic signal shall be installed and properly functioning before the removal of the existing stop sign(s) is permitted. If the existing intersection is enhanced traffic control features, such as stop lines, double indicated stop signs, oversized signs, advanced warning stop ahead signs, rumble strips on the approaches or flashing beacons located overhead or on the shoulders then these features shall be maintained for the duration of the project or until the permanent traffic control plan has been implemented.

Whenever the staging of the Work requires that the traveled way be relocated or realigned the Contractor shall reinstall all enhanced traffic control features noted above on the newly constructed sections of the Work. The cost of relocating the stop lines, stop signs, advanced warning signs, the rumble strips and the flashing beacons shall be included in the price bid for Traffic Control - Lump Sum unless individual pay items are included in the Contract for rumble strips and/or flashing beacons. When pay items are included in the Contract for rumble strips or flashing beacons then these items will be paid per each.

When staging requires the relocation or realignment of an existing stop condition, it may be necessary to consider the addition of enhanced traffic control features even though none existed at the original location. Horizontal and vertical alignment changes at a new location may have decreased or restricted sight distance or the stop condition may occur sooner than in the previous alignment. If these conditions occur, then the Engineer and/or the WTCS should consider additional measures to enhance the motorist's awareness of the changes even though the staging plans may not address enhanced features. Stop signs should be a minimum of 36 inches for interim situations. The use of 48 inch stop signs may be warranted under project specific conditions. Flags may be used on interim/permanent stop signs that are mounted at seven (7') feet in height for a short duration in order to direct additional attention to a new or relocated stop sign(s). Flags should not be used for durations exceeding two weeks unless unusual or site specific conditions warrant a longer period of time. The use of Type "A" flashing red light(s) attached to the stop sign(s) may be appropriate during the same period that the flags are in use to increase attention.

The use of rumble strips and/or PCMS may be considered. The use of new rumble strips, where none previously existed, shall have the prior approval of District Traffic Operations before being included as part of the temporary traffic control plan. The message(s) displayed on any PCMS shall have the prior approval of the Engineer and the message(s) shall be included as part of the TTC plan for the interim staging.

The placement of any additional interim ground mounted signs and posts or stop lines shall be considered as incidental to the price bid for Traffic Control - Lump Sum. The installation of rumble strips, flashing beacons or the use of Portable Changeable Message Signs (PCMS) shall be considered as Extra Work unless pay items are included in the Contract.

G. Low Shoulder Signage

1. Low Shoulder for Construction/Reconstruction/Resurfacing Projects

“Low Shoulder” (W8-9) signs shall be erected when a difference in elevation less than four (< 4’) feet from the traveled way, exceeds one inch (> 1”) but does not exceed three inches (≤ 3 ”) between the travel lane and any type of shoulder.

The spacing of the signs shall not exceed one (1) mile and the signs shall be placed immediately past each crossroad intersection. The “Low Shoulder” signs shall remain in place until the difference in elevation is eliminated and the shoulder has been dressed and permanently grassed for a minimum of thirty (30) calendar days. These signs shall be furnished, installed, maintained and removed by the Contractor as part of Traffic Control-Lump Sum. These signs shall be fluorescent orange with black borders.

2. Shoulder Drop-Off for Construction/Reconstruction/Resurfacing Project

“Shoulder Drop-Off” (W8-17) signs shall be used when a difference in elevation, less than four feet (< 4’) from the traveled way, exceeds three inches (> 3”) and is not protected by positive barrier protection. These warning signs shall be placed in advance of the drop-off.

The spacing of the signs shall not exceed one (1) mile and the signs shall be placed immediately past each crossroad intersection. The “Shoulder Drop-Off” signs shall remain in place until the difference in elevation is eliminated and the shoulder has been dressed and permanently grassed for a minimum of thirty (30) calendar days. These signs shall be furnished, installed, maintained, and removed by the Contractor as part of Traffic Control-Lump Sum. These signs shall be black borders on fluorescent orange background.

H. Bump Signage

A bump sign (W8-1) shall be utilized when a transverse joint in the pavement structure has a vertical difference in elevation of three quarters ($\geq 3/4$ ”) of an inch or greater in depth with no horizontal taper to ramp the traffic from one elevation to the other. This condition typically occurs at approach slabs during pavement milling operations and at transverse joints in asphaltic pavement lifts. Other conditions include utility and storm drainage repairs that require concrete placement for patching and/or steel plating.

The W8-1 sign shall be placed sufficiently in advance to warn the motorist of the condition.

I. Sign Visibility

All existing, interim and new permanent signs shall be installed to be completely visible and legible for an advance distance in compliance with the MUTCD. Any clearing required for maintaining the line of sight to existing, interim or permanent signs shall be done as part of the requirements of the TTC plan. The clearing shall include any advance warning signs, both interim and permanent, that are installed as a part of the Work including advance warning signs that are installed outside the limits of the project. Limbs, brush, construction equipment and materials shall be kept clear of the driver’s line of sight to all signs that are part of the TTC plan.

150.3.04 Advance Warning Signs

A. Project Signs - All Type of Highways

Advance warning signs shall be placed ahead of the work area in accordance with Part 6 of the MUTCD and unless noted below shall include a series of at least three advance road work (W20-1) signs placed at the termini of the project. The series shall have the legend ROAD WORK (1500 FEET, 1000 FEET, AND 500 FEET).

At grade intersecting roadways and on-ramps shall be signed with a minimum of one ROAD WORK AHEAD sign.

When work terminates at a “T” intersection, a minimum of one “ROAD WORK AHEAD” sign shall be placed in advance of the intersection and one “END ROAD WORK” sign shall be placed at the termination end of the intersection. Field conditions may require the use of additional warning signage.

1. State Routes

Advanced Warning Signs on State Routes shall be a minimum dimension of forty-eight inches by forty-eight inches (48" x 48"). When a State Route intersects a project which consists of adding travel lanes, reconstructing an existing roadway or new location work, the State Route approaches shall have a minimum of three (W20-1) advanced warning signs (1500 ft., 1000 ft., 500 ft.). The termination end of an intersecting State Route shall have END ROAD WORK signage.

The W20-1 signs shall be placed at the termini of the project or sufficiently in advance of the termini to allow for lane shifts, lane closures and other activities which may also require advanced warning signs. The advanced warning signs for the project should not overlap with the advanced warning signs for lane shifts, lane closures, etc.

The length of a work zone should be held to the minimum length required to accomplish the Work. If a project has multiple individual worksites within the overall limits of the project, each site should be signed individually if the advance warning signs for each site can be installed without overlapping an adjacent worksite. As soon as the work is completed at any individual site, the warning signs shall be removed from that site.

Project mileage indicated on the G20-1 sign shall be the actual project mileage rounded up to the nearest whole mile. Projects less than two (< 2) miles in length or individual worksites that are part of a multiple worksite project may delete this sign. The G20-1 sign shall be forty-eight inches by twenty-four inches (48" x 24") and the G20-2 sign shall be forty-eight inches by twenty-four inches (48" x 24").

2. Interstate, Limited Access and Multilane Divided Highways

In addition to the W20-1 signs required at 500 ft., 1000 ft. and 1500 ft., multi-lane divided highways shall also have additional advanced warning signs installed with the legend "ROAD WORK (2 MILES, 1 MILE and 1/2 MILE). All construction warning signs on divided highways shall be double indicated (i.e., on the left and right sides of the roadway.) If the use of the half (1/2) mile, one (1) mile and two (2) mile advanced warning signs cause an overlap with other work or do not benefit field conditions then the Engineer may review the use of these signs and eliminate their installation. When the posted speed limit is fifty (≤ 50) mph or less, the one-half (1/2) mile, one (1) mile and two (2) mile signs should be eliminated especially in urban areas.

The W20-1 advance warning signs for ROAD WORK 500 FEET; 1000 FEET; and 1500 FEET shall be temporarily covered when work involving the advanced warning signs for lane shifts and lane closures overlap these signs. The ROAD WORK 1/2 MILE, ROAD WORK 1 MILE, and ROAD WORK 2 MILES shall be in place when the 500, 1000 and 1500 foot signs are temporarily covered.

When the Temporary Traffic Control zone already has advanced warning (W20-1) signs installed the W20-1 signs required for lane closures under Standard 9106 should be eliminated.

3. Ramp Work on Limited Access Highways

The work zone shall not be signed for the entire length of the mainline of a limited access highway when only short individual worksites, interchange or ramp work is being performed.

When work is restricted to ramp reconstruction or widening activities, the advance warning signs on the mainline section of the limited access highway shall be limited to the use of portable advance warning signs. These portable advance warning signs shall only be utilized when work activity is within the gore point of the ramp and the mainline traveled way or work is active in the acceleration/deceleration lane adjacent to the mainline traveled way. Portable advance warning signs (W20-1: 1500 ft. /1000 ft. /500 ft.) shall be installed on the traveled way of the limited access highway when the above conditions are present. The advance warning signs shall be installed only in one direction where work is active. All portable signs shall be double indicated. When work is not active, the ramp work shall be advanced warned by the use of a single forty-eight inches by forty-eight inches (48" x 48") "ROAD WORK AHEAD" (W20-1) with an "ON RAMP" plaque (W13-4p) sign along the right shoulder of the mainline traveled way prior to the beginning of the taper for the deceleration lane. Differences in elevation shall be in compliance with the requirements of Subsection 150.3.11 prior to the removal of the portable (W20-1) advanced warning signs from the mainline.

B. Highway Work Zone

In accordance with Georgia Code, O.C.G.A. § 40-6-188, all sections or segments of the roadway under construction or reconstruction shall be signed as a Highway Work Zone except non-state highway two-lane two-way resurfacing projects. Two conditions can be applied to a Highway Work Zone. Condition 1 is when no reduction in the existing speed limit is required. Condition 2 is when worksite conditions require a reduction of the speed limit through the designated Work Zone. Properly marking a Highway Work Zone shall include the following minimum requirements:

1. No Reduction in the Existing Posted Speed Limit in Highway Work Zone

- a. Signage shall be posted at the beginning point of the Highway Work Zone warning the traveling public that increased penalties for speeding violations are in effect. The beginning point of Highway Work Zone is at the project limits, start of work zone, or at the start of the first taper. The HWZ-2 sign shall be placed a minimum of 600 feet in advance of the Highway Work Zone and shall not be placed more than 1000 feet in advance of the Work Zone. If no speed reduction is required, it is recommended that the HWZ-2 be placed at 750 feet from the work area between the ROAD WORK 500 FT. and the ROAD WORK 1000 FT. signs.

HWZ-2 signs shall be placed at intervals not to exceed one mile for the length of the project. HWZ-2 signs should be placed on the mainline after all major intersections except State Routes. State Routes shall be signed as per the requirements for intersecting roadways below.

- b. The existing speed limit shall be posted at the beginning of the Work Zone. Existing Speed Limit signs (R2-1) shall be maintained.
- c. Intersecting state routes shall be signed in advance of each intersection with the Work Zone with an HWZ-2 sign to warn motorists that increased fines are in effect. All other intersecting roadways that enter into a designated Highway Work Zone may be signed in advance of each intersection with the Work Zone. When construction equipment and personnel are present in the intersection on the mainline of a multi-lane roadway, the intersecting side roads shall be signed in advance with HWZ-2 signs. As soon as the work operation clears the intersection, the signage may be removed.
- d. Sign HWZ-3 shall be posted at the end of the Highway Work Zone indicating the end of the zone and indicating that increased penalties for speeding violations are no longer in effect.
- e. When a designated Highway Work Zone is no longer necessary, all signs shall be removed immediately.

2. Reducing the Speed Limit in a Highway Work Zone

Highway Work Zone signs shall be posted as required in Condition 1 above and in accordance with Detail 150-C.

A “Reduce Speed Limit Ahead” (W3-5) sign shall be posted 600 feet prior to the reduced speed limit.

Then a “Speed Limit” signage (R2-1) for the reduced speed limit shall be erected at the beginning of the Work Zone. Additional signs shall be placed at whichever is least:

- a. on non-interstate roads after every junction with a numbered (state or U.S.) route.
- b. on interstates entrance ramp 1,500 feet from the end of the entrance taper. Detail 150-D
- c. on non-interstate and interstate, a maximum spacing of no greater than one (1) mile apart.

On multi-lane divided highways, the speed limit signs shall be double indicated when the reduced speed is in use.

Additional signs may be necessary to adjust for actual field conditions.

For limited access (interstate) highways and controlled access multi-lane divided highways, the posted speed limit shall be reduced as required below.

When any one or more of the following conditions exist and the existing speed limit is sixty-five (65) mph or seventy (70) mph, the speed limit shall be reduced by ten (10) mph. If the existing speed limit is sixty (60) mph, the speed limit should be reduced by five (5) mph. If the existing speed limit is fifty-five (≤ 55) mph or less, the Contractor can only reduce the speed limit with the prior approval of the Engineer. The reduction in the speed limit shall be no greater than ten (10) mph:

- a) Lane closure(s) of any type and any duration.
- b) The difference in elevation exceeds two inches ($> 2''$) adjacent to a travel lane as shown in Subsection 150.3.11, Detail 150-E, Detail 150-F.
- c) Any areas where equipment or workers are within ten feet (10') of a travel lane.
- d) Temporary portable concrete barriers located less than two feet (2') from the traveled way.
- e) As directed by the Engineer for conditions distinctive to this project.

When the above conditions are not present, the speed limit shall be immediately returned to the existing posted speed limit. A speed reduction shall not be put in place for the entire length of the project unless conditions warranting the speed reduction are present for the entire project length. All existing speed limit signs within the temporary speed reduction zone shall be covered or removed while the temporary reduction in the speed limit is in effect. All signs shall be erected to comply with the minimum requirements of the MUTCD.

At a minimum, the following records shall be kept by the WTCS:

- a) Identify the need for the reduction.
- b) Record the time of the installation and removal of the temporary reduction.
- c) Fully describe the location and limits of the reduced speed zone.
- d) Document any accident that occurs during the time of the reduction.

A copy of the weekly records for reduced speed zones shall be submitted to the Engineer.

When a pilot vehicle is used on a two-lane two-way roadway, the speed limit should not be reduced. For special conditions specific to the Work, on two-lane two-way roadways or multi-lane highways, the Contractor may reduce the posted speed limit with the prior approval of the Engineer.

3. Variable Speed Limit Zones

Projects that are within or extends into variable speed limit zones shall be posted according to condition 1 with HWZ-1, HWZ-2, and HWZ-3 signs. No additional "speed limit" signs, (R2-1), shall be posted. Any reduction or increase in speed limits will be controlled by the normal operation of the variable speed limit system.

Upon request, a maximum speed limit of fifty-five (55) mph **may** be set for the project limits.

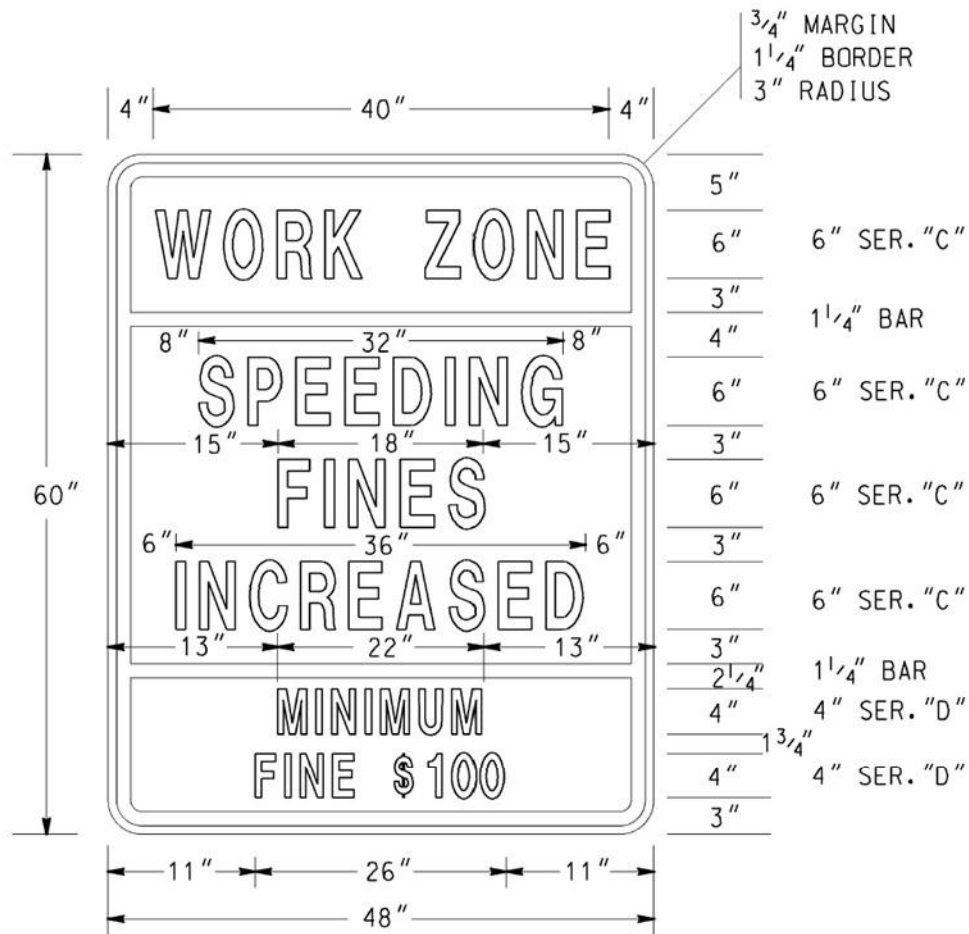

HWZ-2

COLORS

TOP PANEL

LEGEND & BORDER - BLACK (NON-REFL)
 BACKGROUND - FLUORESENT ORANGE

MIDDLE & BOTTOM PANELS

LEGEND & BORDER - BLACK
 BACKGROUND - WHITE

NOTES:

1. ALL HWZ-2 SIGN PANELS SHALL BE RIGID.
2. THE SIZE OF THE HWZ-2 SIGN SHALL NOT BE REDUCED FOR USE ON TWO-LANE ROADWAYS.

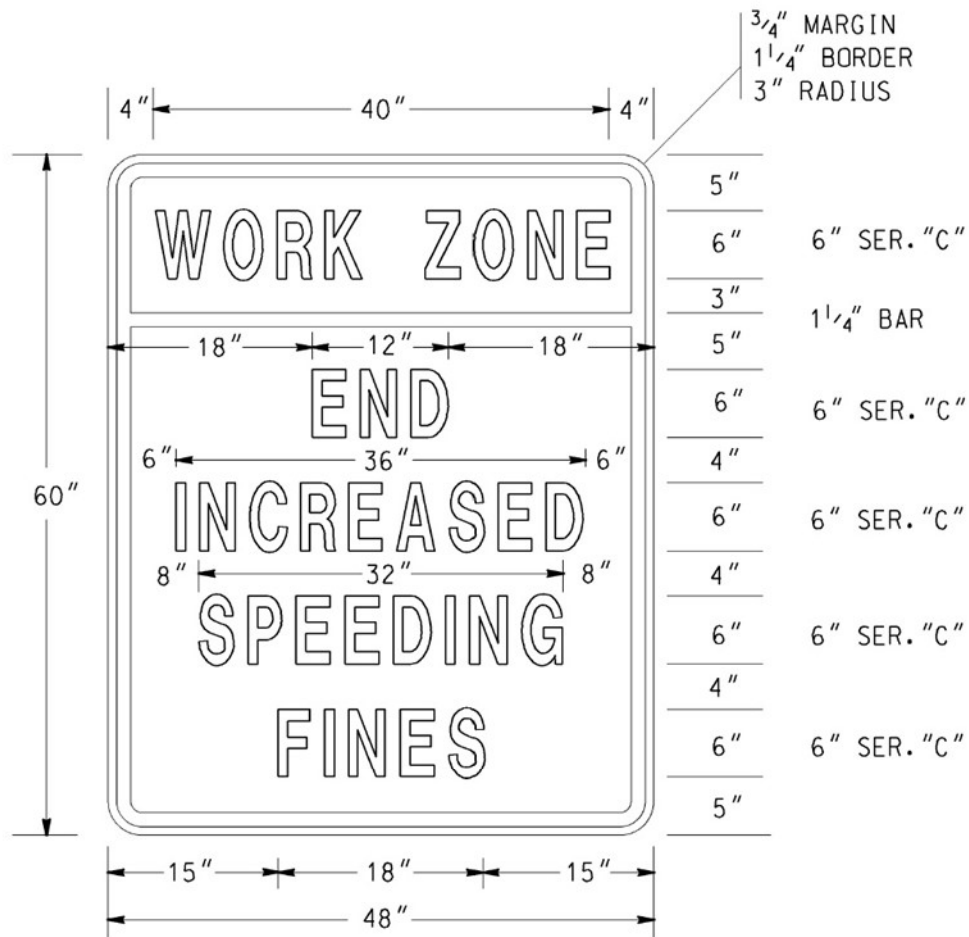

HWZ-3

COLORS

TOP PANEL

LEGEND & BORDER - BLACK (NON-REFL)
 BACKGROUND - FLUORESENT ORANGE

BOTTOM PANEL

LEGEND & BORDER - BLACK (NON-REFL)
 BACKGROUND - WHITE

NOTES:

1. ALL HWZ-3 SIGN PANELS SHALL BE RIGID.
2. THE SIZE OF THE HWZ-3 SIGN SHALL NOT BE REDUCED FOR USE ON TWO-LANE ROADWAYS.

Speed Limit Reduction for Highway Work Zone

Interstate and Multi Lane Divided Highway Signing Shall Be Double Indicated (Right Shoulder and Median Shoulder)

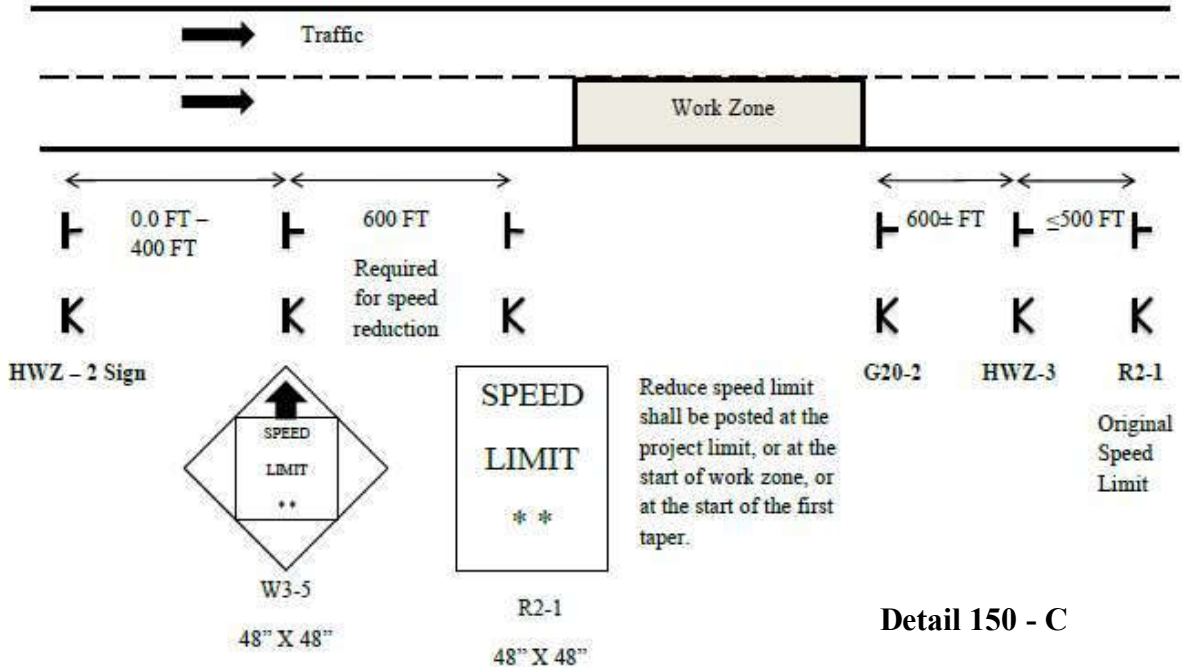

Speed Limit Reduction for Highway Work Zone

At Entrance Ramp for Interstates

Signing Shall Be Double Indicated

Detail 150 - D

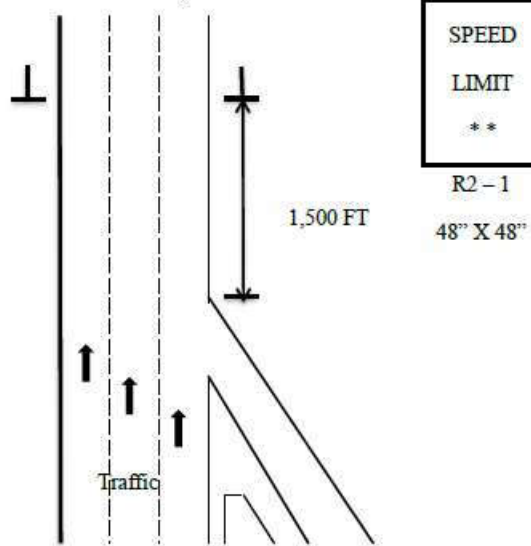

C. Installation/Removal of Work Area Signage

No payment will be made for Traffic Control-Lump Sum until the Work has actually started on the Project. The installation of traffic control signage does not qualify as the start of work. Advanced warning signs shall not be installed until the actual beginning of work activities. Any permanent mount height signs installed as the work is preparing to start shall be covered until all signs are installed unless all signs are installed within seven (≤ 7) calendar days after beginning installation.

All temporary traffic control devices shall be removed as soon as practical when these devices are no longer needed. When work is suspended for short periods of time, temporary traffic control devices that are no longer appropriate, shall be removed or covered.

All construction warning signs shall be removed within seven (≤ 7) calendar days after time charges are stopped or pay items are complete. If traffic control devices are left in place for more than ten (> 10) calendar days after completion of the Work, the Department shall have the right to remove such devices, claim possession thereof, and deduct the cost of such removal from any monies due, or which may become due, the Contractor.

CORRECTIVE LIST WORK: Portable signs shall be utilized to accomplish the completion of all corrective list items, if the corrective list is the only work being performed. The portable signs shall be removed daily. All permanent mount height signs shall be removed prior to the beginning of the corrective list only work, except "Low/Soft Shoulder" signs and any signs that have the prior written approval of the Engineer to remain in place while the corrective list work is in progress.

Failure to promptly remove the construction warning signs within the seven (7) calendar days after the completion of the Work or failure to remove or cover signs when work is suspended for short periods of time shall be considered as non-performance under Subsection 150.7.01.

150.3.05 Shoulder/Lane Closures

A. Approval/Restrictions

All shoulder closures and lane closures of any type or duration shall have the prior approval of the Engineer.

1. Closure Length

The length of a shoulder closure and a lane closure shall not exceed two (2) miles in length excluding the length of the tapers unless the prior approval of the Engineer has been obtained. The Engineer may extend the length of the closure based upon field conditions; however, the length of a work zone should be held to the minimum length required to accomplish the Work. Shoulder closure and Lane Closures shall not be spaced closer than one mile. The advanced warning signs for the Project should not overlap with the advanced warning signs for lane shifts, lane closures, etc.

2. Duration

The first (7) calendar days in an Urban area and the first three (3) calendar days in a Rural area of any lane closure shall be signed and marked as per Georgia Standard 9106 "Traffic Control Detail for Lane Closure on Multi-Lane Divided Highway" or Georgia Standard 9107 "Traffic Control Detail for Lane Closure on Multi-Lane Undivided Highway". However, lane closures that exist for a duration longer than three (> 3) calendar days may be signed and marked as per the details in Georgia Standard 9121 "Tapers, Signs, and Markings for Passing Lanes", provided the prior approval of the Engineer is obtained. The approved lane drop shall utilize a PCMS and only the signs and markings shown for the termination end of the lane drop in Georgia Standard 9121. All warning signs in the lane drop sequence shall be used. Drums may be substituted for the Type I Crystal Delineators at the same spacing.

B. Shoulder Closures

In accordance with MUTCD 6G.07, when paved shoulders, having a width of eight feet ($\geq 8'$) or more are closed, at least one (1) advance warning sign shall be used. The sign(s) should read SHOULDER CLOSED (W21-5a). The signs are only posted on the side with the shoulder closure. Where the downstream end of the shoulder closure extends beyond the distance

that can be perceived by road users, a supplementary plaque bearing the message NEXT XX FEET(W16-4P) or MILES (W7-3aP) should be placed below the SHOULDER CLOSED (W21-5a) sign. These signs shall be placed 500 feet prior to the shoulder closure. For multi-shoulder closures, the Shoulder Closed sign shall be repeated after two (2) miles at 500 feet prior to the next shoulder closure.

A shoulder closure will require a shoulder taper of $(1/3) L$ (L =merging taper length). Traffic drums shall be used for the taper. Arrow boards are not required.

If positive barriers are used to close the shoulder, the taper and drums shall be in accordance with Standard 4960, Temporary Barrier (End Treatment Options). The approach end of the barrier taper should be 10:1 or flatter slope.

C. Lane Closure

1. Advance Warning Signs

The Advance Warning signs shall be in accordance with MUTCD and Georgia Standard 9106 “Traffic Control Detail for Lane Closure on Multi-Lane Divided Highway” and Georgia Standard 9107 “Traffic Control Detail for Lane Closure on Multi-Lane Undivided Highway”.

When the Temporary Traffic Control zone already has advanced warning (W20-1) signs installed the W20-1 signs required for lane closures under Standard 9106 and 9107 should be eliminated.

For Interstate, Limited Access and Multi-lane Divided Highways, an additional PCMS shall be placed one (1) mile in advance of a lane closure with a message denoting the appropriate lane closure one (1) mile ahead. No other message shall be displayed on this PCMS. The PCMS shall be placed on the outside shoulder in accordance with Detail 150-B [PCMS]. This is in addition to the other traffic control devices required by Standard 9106.

At the discretion of the Engineer, the Contractor may start placing advance warning signs a half-hour (1/2 hr.) prior to the lane closure.

2. Transition Area – Taper

Drums shall be used on all transition tapers. If traffic drums with retroreflectivity of less than type VI are used for a merge taper that exists into the night, all drums located in the taper shall have, for the length of the taper only, a six inch (6”) fluorescent orange (ASTM Type VI, VII, VIII, IX or X) reflectorized top stripe on each drum. The top six inch (6”) stripe may be temporarily attached to the drum while in use in a taper. The Engineer may allow the fluorescent orange reflectorized six inch (6”) top stripe on each drum in a merging taper to remain in place during daylight hours provided there is a lane closure(s) with a continuous operation that begins during one nighttime period and ends during another nighttime period. All drums that have the six inch (6”) top stripe permanently attached shall not be used for any other conditions.

In accordance with MUTCD (6C.08), the minimum length for a merging taper for a lane closure on the travel way shall be as shown in Table 150-1:

TABLE 150-1

| Posted Speed Limit, MPH | Lane Width 9 Feet | Lane Width 10 Feet | Lane Width 11 Feet | Lane Width 12 Feet | Maximum Drum Spacing in Tapers, (Feet) |
|----------------------------------|-------------------|--------------------|--------------------|--------------------|--|
| Minimum Taper Length (L) in Feet | | | | | |
| 20 | 60 | 70 | 75 | 80 | 20 |
| 25 | 95 | 105 | 115 | 125 | 25 |
| 30 | 135 | 150 | 165 | 180 | 30 |
| 35 | 185 | 205 | 225 | 245 | 35 |
| 40 | 240 | 270 | 295 | 320 | 40 |
| 45 | 405 | 450 | 495 | 540 | 45 |
| 50 | 450 | 500 | 550 | 600 | 50 |
| 55 | 495 | 550 | 605 | 660 | 55 |
| 60 | 540 | 600 | 660 | 720 | 60 |
| 65 | 585 | 650 | 715 | 780 | 65 |
| 70 | 630 | 700 | 770 | 840 | 70 |
| 75 | 675 | 750 | 825 | 900 | 75 |

If site conditions require a longer taper, then the taper shall be lengthened to fit particular individual situations.

The length of shifting tapers should be at least one-half (1/2) L.

Multiple Lane Closures:

- a. A maximum of one (1) lane at a time shall be closed with each merging taper.
- b. A minimum tangent length of two (≥ 2) L shall be installed between each individual lane closure taper. The tangent length is part of the transition area. Therefore, only traffic drums can be used in the tangent.

3. Activity Area

The activity area consists of a buffer and the work space. Georgia Standard 9106 “Traffic Control Detail for Lane Closure on Multi-Lane Divided Highway” states “Buffer zones of 300’ minimum, 500’ desirable are required for tangent sections and shall be increased for horizontal or vertical curves due to sight distance considerations”

Georgia Standard 9107 “Traffic Control Detail for Lane Closure on Multi-Lane Undivided Highway” requires a fifty feet (50’) buffer. The buffer shall be increased for horizontal or vertical curves due to sight distance considerations”

The channelization devices are spaced at a maximum of eighty feet (80’).

4. Termination Area

Georgia Standard 9106 “Traffic Control Detail for Lane Closure on Multi-Lane Divided Highway” requires a 150 feet buffer and a minimum 200 feet downstream taper.

Georgia Standard 9107 “Traffic Control Detail for Lane Closure on Multi-Lane Undivided Highway” requires 150 feet downstream taper.

D. Removal of Lane Closures

To provide the greatest possible convenience to the public in accordance with Section 107, the Contractor shall remove all signs, lane closure markings, and devices immediately when lane closure work is completed or temporarily suspended for any length of time or as directed by the Engineer. All portable signs and portable sign mounting devices shall be removed from the roadway to an area which will not allow the sign to be visible and will not allow the sign or sign mounting device to be impacted by traffic. All devices shall be stored beyond the clear zone or behind positive protection.

E. Exit and Entrance Ramps

On multi-lane highways, where traffic has been shifted to the inside lanes, the exit and entrance ramps shall have drums placed on both sides of the ramp. This requirement will apply to any situation where traffic is shifted to contra flows or inside staging lanes to facilitate reconstruction work in the vicinity of exit and entrance ramps. The temporary ramp taper length should be greater than, or equal to, the existing taper length. Interim EXIT gore signs shall be placed at the ramp divergence. The “EXIT OPEN” sign shown in Figure TA-42 of the MUTCD shall be utilized. For exit ramps, drums spacing shall be decreased to ten feet (10’) for 200 feet in advance of the temporary gore and be decreased to ten feet (10’) for the first 100 feet of the temporary gore, and throughout the exit ramp. For on-ramps, drums should be used 200 feet prior to the ramp and end 100 feet past the merge taper. The drum spacing for the on ramp may be decreased but should not obstruct the view of the drivers i.e. for the ramp vehicles.

150.3.06 Traffic Pacing Method

A. Pacing of Traffic

With prior approval from the Engineer, traffic may be paced allowing the Contractor up to twenty (20) minutes maximum to work in or above all lanes of traffic for the following purposes:

1. Placing bridge members or other bridge work.
2. Placing overhead sign structures.
3. Other work items requiring interruption of traffic.

The Contractor shall provide a uniformed law enforcement officer with patrol vehicle and blue flashing light for each direction of pacing. The law enforcement officer, Engineer, and flaggers at ramps shall be provided with a radio which will provide continuous contact with the Contractor.

When ready to start the work activity, the law enforcement vehicle will act as a pilot vehicle slowing the traffic, thereby providing a gap in traffic allowing the Contractor to perform the Work. Any on-ramps between the pace and the work area shall be blocked during pacing of traffic, with a flagger properly dressed and equipped with a Stop/Slow paddle. Each ramp should be opened after the law enforcement vehicle has passed.

Pilot vehicles shall travel at a safe pace speed. The Contractor shall provide a vehicle to proceed in front of the law enforcement vehicle and behind the other traffic in order to inform the Contractor’s work force when all vehicles have cleared the area.

Traffic should not be permitted to stop during pacing unless approved by the Engineer.

B. Methods of Signing for Traffic Pacing

At a point not less than 1,000 feet in advance of the beginning point of the pace, the Contractor shall place a PCMS sign with the message “TRAFFIC SLOWED AHEAD **EXPECT** SHORT DELAY”.

150.3.07 Flagging Operations

A. Flaggers

Flaggers shall be provided as required to handle traffic, as specified in the Plans or Special Provisions, and as required by the Engineer.

B. Flagger Certification

All flaggers shall meet the requirements of the MUTCD and shall have received training and a certificate upon completion of the training from one of the following organizations:

National Safety Council
American Traffic Safety Services Association (ATSSA)

On-line classes are not accepted.

Failure to provide certified flaggers as required above shall be reason for the Engineer suspending work involving the flagger(s) until the Contractor provides the certified flagger(s). Flaggers shall have proof of certification and valid identification (photo I.D.) available any time they are performing flagger duties.

C. Flagger Appearance and Equipment

Flaggers shall wear Performance Class 2 or better for day time activities. Flaggers shall wear Performance Class 3 or better high-visibility clothing for night time activities. Flagger stations shall be illuminated at night according to MUTCD (6F.82). They shall use a Stop/Slow paddle meeting the requirements of the MUTCD (6E.03) for controlling traffic. The Stop/Slow paddles shall have a shaft length of seven feet ($\geq 7'$) minimum. The Stop/Slow paddle shall be retroreflectorized for both day and night usage. In addition to the Stop/Slow paddle, a flagger may use a flag as an additional device to attract attention. This flag shall meet the minimum requirements of the MUTCD (6E.03). The flag shall, as a minimum, be twenty-four inches ($\geq 24''$) square and red or red/orange in color.

D. Flagger Warning Signs

Signs for flagger traffic control shall be placed in advance of the flagging operation, in accordance with the MUTCD and Georgia Standard 9102 "Traffic Control Detail for Lane Closure on Two-Lane Highway". In addition, signs at regular intervals, warning of the presence of the flagger shall be placed beyond the point where traffic can reasonably be expected to stop under the most severe conditions for that day's work.

E. Pilot Vehicle Requirements

Pilot vehicles should be required during placement of bituminous surface treatment or asphaltic concrete on two-lane roadways unless otherwise specified. Pilot vehicles shall meet the requirements of the MUTCD (6C.13).

F. Automated Flagger Assistance Devices

The Contractor may request, in writing, the use of Automated Flagger Assistance Devices (AFAD). The equipment shall meet the requirements of MUTCD (6E.04). As a part of this request, the Contractor shall also submit an alternate temporary traffic TTC plan in the event of a failure of the AFAD. Any alternate plan that requires the use of flaggers shall include the use of certified flaggers. The Contractor shall obtain the approval of the Engineer before the use of any AFAD will be permitted.

G. Portable Temporary Traffic Control Signals

The Contractor may request, in writing, the substitution of portable temporary traffic control signals for flaggers on two-lane two-way roadways provided the temporary signals meets the requirements of the MUTCD, Section 647, and subsection 150.2.11. As a part of this request, the Contractor shall also submit an alternate TTC plan in the event of a failure of the signals. Any alternate plan that requires the use of flaggers shall include the use of certified flaggers. The Contractor shall obtain the approval of the Engineer before the use of any portable temporary traffic control signals will be permitted.

150.3.08 Traffic Signals

A. Responsibility/Cost

If the sequence of operations, staging, or the TTC plan requires the relocation or shifting of any components of an existing traffic signal system then any work on these traffic signals will be considered as part of Traffic Control – Lump Sum.

B. Law Enforcement Officer Requirement

In accordance with Georgia law § 40-6-20, law enforcement officers shall be used to regulate and maintain traffic control at functioning signalized intersections when lane closures or traffic shifts block or restrict movements causing interference with road user flows and will not allow the activated traffic signal to guide the traffic through the signal site.

150.3.09 Mobile Operations

A mobile operation is defined by a minimum speed of three (3) mph. When pavement markings (centerlines, lane lines, and edge lines) are applied in a continuous operation by moving vehicles and equipment, the following minimum equipment and warning devices shall be required. These devices and equipment are in addition to the minimum requirements of the MUTCD.

All vehicles shall be equipped with the official slow moving vehicle symbol sign. All vehicles shall have a minimum of two (2) flashing or rotating beacons visible in all directions. All protection vehicles shall have an arrow panel mounted on the rear. All vehicles requiring an arrow panel shall have, as a minimum, a Type B panel. All vehicle mounted signs shall be mounted with the bottom of the sign a minimum height of forty-eight inches (48") above the pavement. All sign legends shall be covered or removed from view when work is not in progress.

The lead vehicle may be a separate vehicle or the work vehicle applying the pavement markings may be used as the lead vehicle. The lead vehicle shall have an arrow panel mounted so that the panel is easily visible to oncoming (approaching) traffic. The arrow panel should operate in the caution mode.

The work vehicle(s) applying markings shall have an arrow panel mounted on the rear. The arrow panel should typically operate in the caution mode. The work vehicle placing cones shall follow directly behind the work vehicle applying the markings.

A protection vehicle shall follow the last work vehicle at all times and shall be equipped with a truck mounted attenuator that shall be certified for impacts not less than sixty-two (62) mph in accordance with MASH/NCHRP350 Test Level Three (3).

150.3.10 Pavement Markings

A. General

Full pattern pavement markings in conformance with Section 3A and 3B, except 3B.02, of the MUTCD are required on all courses before the roadway is opened to traffic, unless noted in this section. No passing zones shall be marked to conform to Subsection 150.3.10.D.1.b. During construction and maintenance activities on all highways open to traffic, both existing markings and markings applied under this Section shall be fully maintained until Final Acceptance. If the pavement markings are, or become, unsatisfactory in the judgment of the Engineer due to wear, weathering, or construction activities, they shall be restored immediately.

Markings on the final surface course, which must be removed, shall be a removable type. The Contractor will be permitted to use paint, thermoplastic, or tape on pavement which is to be overlaid as part of the Project, unless otherwise directed by the Engineer. Partial (skip) reflectorization (i.e. reflectorizing only a portion of a stripe) will not be allowed.

1. Resurfacing Projects

Pavement markings shall be provided on all surfaces that are placed over existing markings. Interim and final markings shall conform in type and location to the markings that existed prior to resurfacing unless changes or additions are noted in the Contract. The replacement of parking spaces will not be required unless a specific item or note has been included in the Contract. Any work to make additions to the markings that existed prior to resurfacing is to be considered as extra work.

2. Widening and Reconstruction Projects

If the lane configuration is altered from the preconstruction layout then pavement markings will be as required by the Plans or the Engineer.

3. New Location Construction Projects

Pavement marking plans will be provided.

B. Installation and Removal of Pavement Markings

1. Installation

All pavement markings, both interim and permanent, shall be applied to a clean surface. The Contractor shall furnish the layout and preline the roadway surface for the placement of pavement markings applied as part of the TTC plan. All interim marking tape and RPM's on the final surface shall be removed prior to the placement of the final markings.

The Contractor shall sequence the Work in such a manner as to allow the installation of markings in the final lane configuration at the earliest possible stage of the Work.

2. Removal

Markings no longer applicable shall be removed in accordance with Section 656.

The elimination of conflicting pavement markings by overpainting with unapproved paint or any type of liquid asphalt is not acceptable.

3. Intermediate Surface

Interim markings shall be removed by methods that will cause minimal damage to the pavement surface, while also ensuring that traveling public will not be confused or misdirected by any residual markings remaining on the intermediate surface. The use of approved black-out tape and black-out paint (manufactured for the sole purpose of covering existing pavement markings) may be permitted on some interim surfaces, provided the results are satisfactory to the Engineer.

4. Final Surface

No interim paint or thermoplastic markings will be permitted on any final surface unless the interim markings are in alignment with the location of the permanent markings and the interim marking will not interfere or adversely affect placement of the permanent markings. The proposed method of removal for layout errors that require markings to be removed from the final surface shall have the prior approval of the Engineer. Any damage to the final pavement surface caused by the pavement marking removal process shall be repaired at the Contractor's expense by methods acceptable and approved by the Engineer. Section 400 shall apply when corrective measures are required. The use of black-out tape or black-out paint will not be permitted under any circumstance to correct layout errors on any final surface.

Traffic shifts that are done on the final surface shall be accomplished using interim traffic marking tape that can be removed without any blemishing of the final surface. Interim traffic marking tape shall be used on any of the following final surfaces; asphaltic concrete, Portland cement concrete, and bridge deck surfaces. The Contractor may propose alternate traffic markings and removal methods on the final surface. Submitted proposals shall include the type of material, method of removal and a cost comparison to the traffic marking tape method. Prior to any approval, the Contractor shall field demonstrate to the satisfaction of the Engineer that the proposed traffic markings can be removed without any blemishing of the final surface. If the proposal is determined to be acceptable, a supplemental agreement will be executed prior to the installation of the proposed alternate traffic markings. The supplemental agreement shall denote the type of traffic marking materials, method of removal and any cost and/or time savings to the Department. The Department will not consider or participate in any cost increase that may result from implementing the proposed alternate method.

5. Pay Factor Reduction for Asphaltic Concrete Final Surfaces

When the correction of an error in the layout of the final pavement markings requires the final surface to be grounded, blemished, scarred, or polished the pay factor shall be reduced to 0.95 for the entire surface area of the final topping that has a blemish, polished or a scarred surface. The reduced pay factor shall not be confined to only the width and length of the stripe or the dimensions of the blemished areas, the whole roadway surface shall have the reduced pay factor applied. The area of the reduced pay factor shall be determined by the total length and the total width of the roadway affected. If the affected area is not corrected, the reduction in pay shall be deducted from the final payment

for the topping layer of asphaltic concrete. The Engineer shall make the final determination whether correction or a reduced pay factor is acceptable.

The eradication of pavement markings on intermediate and final concrete surfaces shall be accomplished by a method that does not grind, polish, or blemish the surface of the concrete. The method used for the removal of the interim markings shall not spall chip the joints in the concrete and shall not damage the sealant in the joints. Any joint or sealant repairs shall be included in the bid price for Traffic Control-Lump Sum. The proposed method of removal shall have the prior approval of the Engineer.

Failure to promptly remove conflicting or non-applicable pavement markings shall be considered as non-performance under Subsection 150.7.01.

6. Preparation and Planning for Traffic Shifts

When shifting of traffic necessitates removal of centerline, lane lines, or edge lines, all such lines shall be removed prior to, during, or immediately after any change to present the least interference with traffic. Interim traffic marking tape shall be used as a temporary substitute for the traffic markings being removed.

Before any change in traffic lane(s) alignment, marking removal equipment shall be present on the project for immediate use. If marking removal equipment failures occur, the equipment shall be repaired or replaced (including leasing equipment if necessary), so that the removal can be accomplished without delay.

Except for the final surface, markings on asphaltic concrete may be obliterated by an overlay course, when approved by the Engineer. When an asphaltic concrete overlay is placed for the sole purpose of eliminating conflicting markings and the in place asphaltic concrete section will allow, said overlay will be eligible for payment only if designated in the Plans. Overlays to obliterate lines will be paid for only once and further traffic shifts in the same area shall be accomplished with removable markings. Only the minimum asphaltic concrete thickness required to cover lines will be allowed. Excessive build-up will not be permitted. When an overlay for the sole purpose of eliminating conflicting markings is not allowed, the markings no longer applicable shall be removed in accordance with Section 656.

C. Raised Pavement Markers

Retroreflective raised pavement markers (RPMs) shall be placed as listed below for all asphaltic concrete pavements before the roadway is open to traffic, unless noted this section. On the final surface, RPMs shall be placed according to the timeframes specified in Subsection 150.3.10.D for full pattern pavement markings. When Portland Cement Concrete is an intermediate or final surface and is open to traffic, one (1) calendar day is allowed for cleaning and drying before the installation of RPMs is required.

Raised pavement markers are not allowed on the right edge lines under any situation.

Retroreflective raised pavement markers (RPMs) shall be placed and/or maintained on intermediate pavements surfaces on all highways that the final ride surface is not completed within 45 calendar days which is open to traffic. This includes all resurfacing projects along with widening and reconstruction projects. The RPMs shall be placed as follows:

1. Supplementing Lane Lines:
 - a. Eighty foot (80') center on skip lines with curvature less than three degrees. (Includes tangents)
 - b. Forty foot (40') centers on solid lines and all lines with curvature between three degrees and six degrees.
 - c. Twenty foot (20') centers on curves over six degrees.
 - d. Twenty foot (20') centers on lane transitions or shifts.
2. Supplementing Ramp Gore Lines:
 - a. Twenty foot (20') centers, two each, placed side by side.

3. Other Lines:

- a. As shown on the Plans or directed by the Engineer.

D. Exceptions for Interim Markings

Some exceptions to the time of placement and pattern of markings are permitted as noted below; however, full pattern pavement markings are required for the completed project.

1. Two-Lane, Two-Way Roadways

- a. Skip Lines

If used, interim temporary tape or paint skip (broken) stripe may only be used for a maximum of three (3) calendar days. The stripes shall be at least two feet ($> 2'$) long with a maximum gap of thirty-eight feet ($\leq 38'$). On curves greater than six degrees ($>6^\circ$), a one-foot ($1'$) stripe with a maximum gap of nineteen feet ($\leq 19'$) shall be used. In lane shift areas, solid lines will be required.

Interim raised pavement markers may be substituted for the interim skip (broken) stripes. If raised pavement markers are substituted for the two foot ($2'$) interim skip stripe, three (3) markers spaced at equal intervals over a two feet ($2'$) distance will be required. No separate payment will be made if the interim raised pavement markers are substituted for interim skip lines.

Interim raised pavement markers shall be retro-reflective, shall be the same color as the pavement markers for which they are substituted, and shall be visible during daytime.

The type of interim marker and method of attachment to the pavement shall be approved by the Office of Materials and Testing but in no case will the markers be attached by the use of nails. Flexible reflective markers, Type 14 or Type 15, may be used for a maximum of three (3) calendar days as an interim marker. Any flexible reflective markers in use shall be from the QPL-76.

The interim raised pavement markers shall be maintained until the full pattern pavement markings are applied. At the time full pattern markings are applied the interim raised markers shall be removed in a manner that will not interfere with application of the full pattern pavement markings.

- b. No Passing Zones Two-Lane, Two-Way Roadways

Passing zones shall be re-established in the locations existing prior to resurfacing unless otherwise noted in the Contract. No changes to the location of passing zones shall be done without the written approval of the Engineer. For periods not to exceed three (3) calendar days where interim skip centerlines are in place, no-passing zones shall be identified by using post or portable mounted DO NOT PASS regulatory signs (R4-1) twenty-four inches by thirty inches ($24'' \times 30''$) at the beginning and at intervals not to exceed one-half ($\leq 1/2$) mile within each no-passing zone. A post or portable mounted PASS WITH CARE regulatory sign (R4-2) twenty-four inches by thirty inches ($24'' \times 30''$) shall be placed at the end of each no-passing zone. Post mounted signs shall be placed in accordance with the MUTCD. Portable signs shall be secured in such a manner to prevent misalignment and minimize the possibility of being blown over by weather conditions or traffic.

On new location projects and on projects where either horizontal or vertical alignments has been modified, the location of No-Passing Zones will be identified by the Engineer.

- c. Edge lines

- Bituminous Surface Treatment Paving

Edge lines will not be required on intermediate surfaces (including asphaltic concrete leveling for bituminous surface treatment paving) that are in use for a period of less than sixty (<60) calendar days except at bridge

approaches, on lane transitions, lane shifts, and in such other areas as determined by the Engineer. On the final surface, edge lines shall be placed within thirty (≤ 30) calendar days of the time that the final surface was placed.

- All Other Types of Pavement

Edge lines will not be required on intermediate surfaces that are in use for a period of less than thirty (< 30) calendar days except at bridge approaches, on lane transitions, lane shifts, and in such other areas as determined by the Engineer. On the final surface, edge lines shall be placed within fourteen (≤ 14) calendar days of the time that the surface was placed.

2. Multi-Lane Highways – With No Paved Shoulder(s) or Paved Shoulder(s) Four Feet or Less ($\leq 4'$)

a. Undivided Highways (Includes Paved Center Turn Lane)

- Centerlines and No-Passing Barrier-Full Pattern centerlines and no-passing barriers shall be restored before opening to traffic.
- Lane lines- Interim skip (broken) stripe as described in Subsection 150.3.10.D.1.a. may be used for periods not to exceed three (≤ 3) calendar days. Skip lines are not permitted in lane shift areas. Solid lines shall be used.
- Edge lines- Edge lines shall be placed on intermediate and final surfaces within three (3) calendar days of obliteration.

b. Divided Highways (Grass or Raised Median)

- Lane lines- Full pattern skip stripe shall be restored before opening to traffic. Skip lines are not permitted in lane shift areas. Solid lines shall be required.
- Centerline/Edge line- Solid lines shall be placed on intermediate and final surfaces within three calendar days of obliteration.

3. Limited Access Roadways and Roadways with Paved Shoulders Greater Than Four Feet ($> 4'$)

a. Same as Subsection 150.3.10.D.2 except as noted in (b) below.

b. Edge lines-

- Asphaltic Concrete Pavement- Edge lines shall be placed on intermediate and final surfaces prior to opening to traffic.
- Portland Cement Concrete Pavement- Edge lines shall be placed on any surface open to traffic no later than one calendar day after work is completed on a section of roadway. All water and residue shall be removed prior to daily striping.

4. Ramps for Multi-Lane Divided Highways

A minimum of one solid line edge stripe shall be placed on any intermediate surface of a ramp prior to opening the ramp to traffic. The other edge stripe may be omitted for a maximum period of three (3) calendar days on an intermediate surface. Appropriate channelization devices shall be spaced at a maximum of twenty-five feet (25') intervals until the other stripe has been installed.

The final surface shall have both stripes placed prior to opening the ramp to traffic.

5. Miscellaneous Pavement Markings

a. Final Surface

School zones, railroads, symbols, words and other similar markings shall be placed on final surfaces conforming to Section 652 within fourteen (14) calendar days of completion of the final surface. Final markings shall conform to the type of pay item in the Plans. When no pay item exists in the Plans the final markings shall conform to Section 652 for painted markings.

b. Intermediate Surface

Intermediate surfaces that will be in use for more than forty-five (45) calendar days shall have the miscellaneous pavement markings installed to conform to the requirement of Section 652. Under Subsection 150.6, Special Conditions, or as directed by the Engineer these markings may be eliminated.

c. Stop Line

All stop signs and traffic signals shall have temporary twelve inch (12") stop lines placed in accordance with MUTCD (3B.16) on all surfaces prior to opening to traffic. Temporary tape **may** be used.

150.3.11 Differences in Elevations Between Travel Lanes and Shoulders

All time frames and requirements may be changed with the Engineer's approval.

A. Differences in Elevations

Difference in elevations due to construction between travel lanes and/or shoulders within the clear zone should be limited to the following:

1. Difference of two inches ($\leq 2''$) or less between adjacent travel lanes should remain for a maximum period of fourteen (14) calendar days.
2. Difference of two inches ($\leq 2''$) or less between adjacent travel lane and paved shoulder should remain for a maximum of thirty (30) calendar days. Traffic control devices shall be in accordance with Detail 150-G.
3. Difference of greater than two inches ($> 2''$) is permitted for continuous operations. Traffic control devices shall be in accordance with Detail 150-E.
4. Difference of greater than two inches ($> 2''$) between travel lanes and/or shoulders for non-continuous operations will not be allowed for more than a twenty-four (24) hour period. For the first twenty-four (24) hours, traffic control shall be in accordance with Detail 150-E. After twenty-four (24) hours the section should be healed according to Detail 150-H. This condition can exist for a maximum sixty (60) calendar days.
 - a. A single length of area that does not exceed 1000 feet total length may be left open as a startup area for periods not to exceed forty-eight (48) hours provided the Contractor can demonstrate the ability to complete the Work in a proficient manner. Prior approval of the Engineer shall be obtained before any startup area may be allowed.
 - b. For cement stabilized base, work adjacent to the travel lane and/or shoulders shall be healed as per Detail 150-H within forty-eight (48) hours after the seven (7) calendar day curing period is complete for each section placed. During the placement and curing period, traffic control shall be in accordance Detail 150-E.

Failure to meet these requirements shall be considered as non-performance of Work under Subsection 150.7.01.

B. Healed Section

Healed section and traffic control devices should be placed in accordance with Detail 150-H. If crushed stone materials are used to provide a healed section no separate payment will be made for the material used to heal any section. The

Contractor may submit a plan to utilize existing pay items for crushed stone provided the plan clearly demonstrates that the materials used to heal an area will be incorporated into the Work with minimal waste. Handling and hauling of any crushed stone used to heal shall be kept to a minimum. The Engineer shall determine if the crushed stone used to heal meets the Specifications for gradation and quality when the material is placed in the final location.

C. Emergency Situations

Inclement weather, traffic accidents, and other events beyond the control of the Contractor may prevent the Work from being completed as required above. The Contractor shall notify the Engineer in writing stating the conditions and reasons that have prevented the Contractor from complying with the time limitations. The Contractor shall also outline a plan detailing immediate steps to complete the Work. Failure to correct these conditions on the first calendar day that conditions will allow corrective work shall be considered as non-performance of Work under Subsection 150.7.01.

D. Plating

Plating for drainage structures, utility facilities, etc. is prohibited on the interstates. Plating on State Routes and secondary roads will require the prior approval of the project Engineer. Steel plates shall not be used on highways with a posted speed greater than forty-five (45) mph. The plate shall completely cover the pavement cut or excavation. The plate shall be adequately secured and shall provide a safe and reasonable transition to the adjoining roadway surface. An asphalt wedge can be used to provide a smooth transition over the plate(s). Temporary traffic control warning signs W8-24 shall be posted in advance warning motorist about plates in roadway in accordance with the MUTCD. Plating should not remain in place for more than four (4) calendar days.

E. Asphaltic Concrete Resurfacing Projects

1. Shoulder Construction Included as a Part of the Contract

When the placement of asphaltic concrete materials creates a difference in elevation greater than two inches (> 2”) between the earth shoulder (grassed or un-grassed) and the edge of travel lane or between the earth shoulder and a paved shoulder that is less than four feet (< 4’) in width, the Contractor shall place and maintain drums in accordance with the requirements of Subsection 150.2.04.B.3. When the edge of the paved surface is tapered with a safety edge, drums may be spaced at two (2) times the speed limit in MPH. Drums shall remain in place and be maintained until the difference in elevation has been eliminated by the placement of the appropriate shoulder materials.

2 Shoulder Construction Not Included as a Part of the Contract

When the placement of asphaltic concrete materials creates a difference in elevation greater than two inches (> 2”) between the earth shoulder (grassed or un-grassed) and the edge of travel lane or between the earth shoulder and a paved shoulder that is less than four feet (< 4’) in width, the Contractor shall notify the Engineer, in writing, when the resurfacing work including all corrective list items has been completed.

Drums spaced at twenty foot (20') intervals. **Note:** If the travel way width is reduced to less than ten feet (< 10') by the use of drums, vertical panels shall be used in lieu of drums.

Location of drums when Elevation Difference exceeds four inches (> 4")

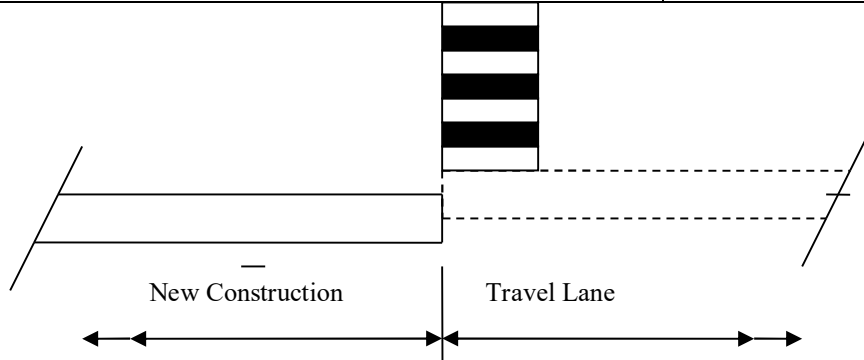

ELEVATION DIFFERENCE GREATER THAN FOUR INCHES (> 4")

DETAIL 150-E

Drums spaced at forty foot (40') intervals.

Location of drums when Elevation Difference is greater than two inches (> 2") to four inches (4")

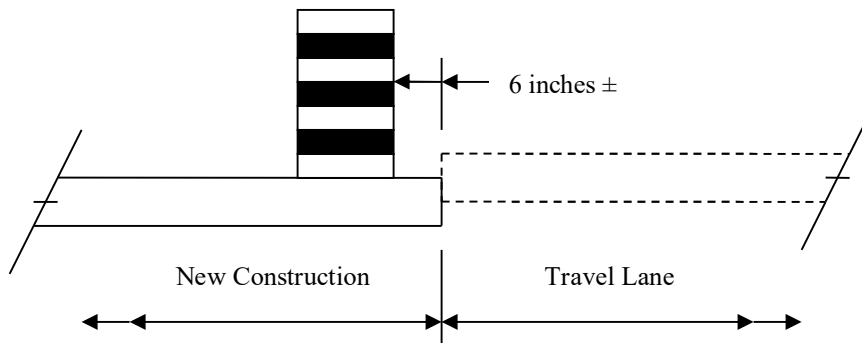

ELEVATION DIFFERENCE GREATER THAN TWO INCHES (> 2") TO
FOUR INCHES (4")

DETAIL 150-F

Drums spaced at eighty foot (80') intervals.

Location of drums when Elevation Difference is two inches ($\leq 2''$) or less.

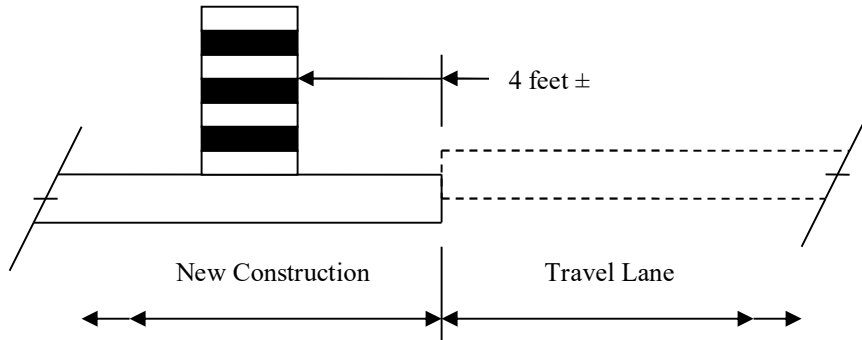

ELEVATION DIFFERENCE OF TWO INCHES ($\leq 2''$) OR LESS

DETAIL 150-G

Location of drums immediately after completion of healed sections spaced at 40 foot (40') intervals

Healed Section

Compacted graded aggregate, subbase material or dirt.

NO STEEPER THAN 4:1

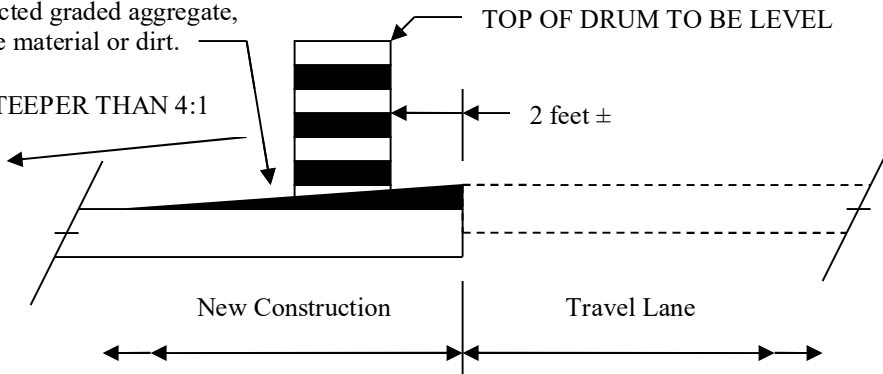

HEALED SECTION

DETAIL 150-H

150.3.12 Work Zone Law Enforcement

Work zone law enforcement consists of utilizing a uniformed law enforcement officer equipped with patrol vehicle and blue flashing lights to enforce traffic laws in construction work zones and the administration of this service. Payment for work zone law enforcement will be made only for the utilization in work zones during lane closures, traffic pacing, or other activities that occur within travel lanes. The Contractor will be responsible for negotiating a rate of reimbursement and making reimbursement to that law enforcement agency.

The Contractor will be responsible for coordinating and scheduling the utilization of the work zone law enforcement. The Engineer may require the use of work zone law enforcement at specific times and locations.

Work zone law enforcement will be required in all work zones during lane closures, traffic pacing, or other activities that occur within travel lanes on the interstate.

150.4 Measurement

150.4.01 Traffic Control Items

A. Traffic Control

When listed as a pay item in the Proposal, payment will be made at the lump sum price bid, which will include all traffic control not paid for separately, and will be paid as follows:

When the first Construction Report is submitted, a payment of twenty-five percent (25%) of the lump sum price will be made. For each progress payment thereafter, the total of the Project percent complete shown on the last pay statement plus twenty-five percent (25%) will be paid (less previous payments), not to exceed one hundred percent (100%).

When no payment item for Traffic Control-Lump Sum is shown in the Proposal, all of the requirements of Section 150 and the Temporary Traffic Control Plan shall be in full force and effect. The cost of complying with these requirements will not be paid for separately, but shall be included in the overall bid submittal.

B. Changeable Message Sign, Portable

Portable changeable message sign will be measured as specified in Section 632.

C. Flashing Beacon Assembly

Flashing beacon assemblies will be measured as specified in Section 647.

D. Pavement Markings

Pavement markings will be measured as specified in Section 150.

E. Portable Impact Attenuators

Each portable impact attenuator will be measured by the unit/array which shall include all material components, hardware, incidentals, labor, site preparation, and maintenance, including spare parts recommended by the manufacturer for repairing accident damage. Each unit will be measured only once regardless of the number of locations installed, moves required, or number of repairs necessary because of traffic damage. Upon completion of the project, the units shall be removed and retained by the Contractor.

F. Signs

When shown as a pay item in the Contract, interim special guide signs will be paid for as listed below. All other regulatory, warning, and guide signs, as required by the Contract, will be paid for under Traffic Control Lump Sum or included in the overall bid submitted.

1. Interim ground mounted or interim overhead special guide signs will be measured for payment by the square foot. This payment shall be full compensation for furnishing the signs, including supports as required, erecting, illuminating overhead signs, maintaining, removing, re-erecting, and final removal from the Project. Payment will be made only one time regardless of the number of moves required.
2. Remove and reset existing special guide signs, ground mount or overhead, complete, in place, will be measured for payment per each. Payment will be made only one time regardless of the number of moves required.
3. Modify special guide signs, ground mount or overhead, will be measured for payment by the square foot. The area measured shall include only that portion of the sign modified. Payment shall include materials, removal from posts or supports when necessary, and remounting as required.

G. Temporary Audible Information Device

Temporary audible information devices are measured as the actual number furnished and installed in accordance with the manufacturer's recommendations, which shall include all necessary materials, equipment, labor, site preparation, maintenance and removal. Each temporary audible information device will be paid for only one time regardless of the number of times it's reused during the duration of the Work. These devices shall remain the property of the Contractor.

H. Temporary Barrier

Temporary barrier shall be measured as specified in Sections 620.

I. Temporary Curb Cut Wheelchair Ramps

Temporary curb cut wheelchair ramps are measured as the actual number formed and poured, complete and accepted, which shall include all necessary materials, equipment, labor, site preparation, maintenance and removal. No additional payment will be made for sawing existing sidewalk and removal and disposal of removed material for temporary wheelchair ramp construction. No additional payment will be made for constructing the detectable warning surface.

J. Temporary Guardrail Anchorage, Type 12

Temporary guardrail anchorage- Type 12 will be measured by each assembly, complete in place and accepted according to the details shown in the Plans, which shall also include the additional guardrail and appurtenances necessary for transition and connection to temporary concrete barrier. Payment shall include all necessary materials, equipment, labor, site preparation, maintenance and removal.

K. Temporary Walkways with Detectable Edging

Temporary walkways with detectable edging will be measured in linear feet (meters), complete in place and accepted, which shall include all necessary materials, equipment, labor, site preparation, temporary pipes, passing spaces, maintenance and removal. Excavation and backfill are not measured separately for payment. No payment will be made for temporary walkways where existing pavements or existing edging (that meets the requirements of MUTCD) are utilized for the temporary walkway. Payment for temporary detectable edging, including approved barriers and channelizing devices, installed on existing pavement shall be included in Traffic Control-Lump Sum.

L. Traffic Signal Installation- Temporary

Temporary traffic signal installation will be measured as specified in Section 647.

M. Work Zone Law Enforcement

When work zone law enforcement is shown as a pay item, work zone law enforcement will be measured for payment by the hour. The Contractor shall provide a daily work record containing the actual number of hours charged by the law enforcement officer. The daily work record shall be compiled on a form provided by the Department, signed by

the law enforcement officer, signed by the Contractor's Worksite Traffic Control Supervisor attesting that the law enforcement was utilized during the time recorded, and then submitted to the Engineer.

Work zone law enforcement will be measured for payment by the hour up to the maximum number of hours included in the Contract. The Engineer may at his discretion increase the maximum number of hours.

Payment shall be full compensation for reimbursing the law enforcement agency and for all cost incurred by the Contractor in coordinating, scheduling, and administering the item work zone law enforcement.

If no work zone law enforcement pay item is included in the Contract, then all work zone law enforcement cost shall be included in Traffic Control – Lump Sum.

150.5 Reserved

150.6 Special Conditions

Special Conditions, if used, will be included elsewhere in the Contract.

150.7 Payment

When shown in the Schedule of Items in the Proposal, the following items will be paid for separately. Payment will be made under:

| | | |
|--------------|---|-----------------|
| Item No. 150 | Traffic control - | Lump sum |
| Item No. 150 | Traffic control, solid traffic stripe ___ inch, (color) | Per linear mile |
| Item No. 150 | Traffic control, skip traffic stripe ___ Inch, (color) | Per linear mile |
| Item No. 150 | Traffic control, solid traffic stripe, thermoplastic 24 inch, color | Per linear mile |
| Item No. 150 | Traffic control, raised pavement markers –all types | Per each |
| Item No. 150 | Remove and reset, existing special guide signs, overhead, complete-in-place | Per each |
| Item No. 150 | Temporary walkways with detectable edging | Per linear foot |
| Item No. 150 | Temporary curb cut wheelchair ramps | Per each |
| Item No. 150 | Temporary audible information device | Per each |
| Item No. 150 | Work Zone Law Enforcement | Per hour |

150.7.01 Enforcement and Adjustments

The safe passage of pedestrians and traffic through and around the temporary traffic control zone, while minimizing confusion and disruption to traffic flow, shall have priority over all other Contractor activities. Continued failure of the Contractor to comply with the requirements of Section 150 - Traffic Control will result in non-refundable deductions of monies from the Contract as shown in this Subsection for non-performance of Work.

Failure of the Contractor to comply with this Specification shall be reason for the Engineer suspending all other work on the Project except erosion control and traffic control, taking corrective action as specified in Section 105, and/or withholding payment of monies due to the Contractor for any work on the Project until traffic control deficiencies are corrected. These other actions shall be in addition to the deductions for non-performance of traffic control.

| SCHEDULE OF DEDUCTIONS FOR EACH CALENDAR DAY OF DEFICIENCIES OF TRAFFIC CONTROL INSTALLATION AND/OR MAINTENANCE | | |
|--|-------------------------|---------------------|
| ORIGINAL TOTAL CONTRACT AMOUNT | | |
| From More Than | To and Including | Daily Charge |
| \$0 | \$100,000 | \$250 |

| | | |
|--------------|--------------|---------|
| \$100,000 | \$1,000,000 | \$650 |
| \$1,000,000 | \$5,000,000 | \$1,300 |
| \$5,000,000 | \$20,000,000 | \$2,000 |
| \$20,000,000 | \$40,000,000 | \$2,600 |
| \$40,000,000 | \$----- | \$4,000 |

DEPARTMENT OF TRANSPORTATION

SPECIAL PROVISION

Section 150—Traffic Control

Retain Section 150 as written and add the following:

150.6 SPECIAL CONDITIONS

A. Lane Closure Restrictions

1. The Contractor shall not perform work or move equipment or materials on the traveled way that interferes with traffic flow on the mainline or local streets prior to 9:00 a.m. or after 4:00 p.m., Monday through Friday, without prior approval of the County.
2. At no time shall there be any lane closures or equipment moved on the travel way on the mainline or local streets between the hours of 6:00 a.m. and 9:00 a.m. or 4:00 p.m. and 7:00 p.m. Monday through Friday, without prior approval from the County.
3. The Contractor shall not perform work or move equipment or materials on the traveled way that interferes with traffic flow on the mainline or local streets on Saturday or Sunday without prior approval of the County. At no time shall there be any lane closures or equipment moved on the travel way on the mainline or local streets between the hours of 9:00 a.m. to 1:00 p.m. on Sundays.