

Quote Package

**CRA GATEWAY SIGNAGE (MONUMENT SIGN)**



Prepared by:  
Poly Inc.



For City of Crestview  
Community Redevelopment Agency  
198 Wilson North  
Crestview, FL 32536

## TABLE OF CONTENTS

### **DIVISION 0 - CONTRACT & BIDDING REQUIREMENTS**

00100	Scope of Work
00200	Geotechnical Report
00300	Quote Schedule
00500	Engineers Joint Contract Documents Committee (EJCDC) Standard Form Contract
00610	Performance Bond
00620	Payment Bond
00700	General Conditions
00800	Supplementary General Conditions
00810	Special Conditions

### **APPENDIX**

Drawings (7 pages) – including Technical Specifications

CRESTVIEW COMMUNITY REDEVELOPMENT AGENCY (CRA)  
GATEWAY SIGNAGE PROJECT  
MONUMENT SIGNAGE  
INVITATION TO BID

The Crestview CRA will accept separate sealed bids quoting the cost for the construction of a CRA Monument Sign at the offices of the City of Crestview, Florida at 198 Wilson Street North Crestview, FL 32536 until **3:15 p.m. (local time) on February 19, 2019**. Bids (which may be referred to in this invitation alternatively as “Quotes”) must be mailed or hand-delivered on or before the above-stated date and time. All properly and timely received bids will be publicly opened and read aloud at 3:15 p.m. on February 19, 2019 in the Crestview City Hall Council Chamber.

Bids should be labeled and addressed as follows:

**“Quote for CRA Gateway Monument Signage”**

Attn: Elizabeth Roy, CRA Administrator  
198 Wilson Street North  
Crestview, FL 32536

Applicants interested in responding to this Invitation to Bid must provide a quotation of the cost to perform the following:

*Scope of Work:*

1. Existing “Welcome to Crestview Sign” at location to be removed by Owner prior to construction.
2. Provide the materials for and construct a new 22’ brick planter/monument “Welcome to Historic Crestview” sign with cast aluminum lettering, including new lighting, as outlined in attached design construction plans in the Appendix.
3. All materials used in construction of the sign shall be new and shall meet the material specifications as shown on the original design drawings in the Appendix.

*General Conditions:*

1. All Work must be done in accordance with applicable City of Crestview, Okaloosa County and State of Florida and/or federal requirements.
2. All materials used shall be new and shall meet the material specifications as shown on the original design drawings in the Appendix to this Invitation to Bid.
3. Contractor shall employ any and all means necessary to prevent damage to adjoining property that may be caused by sign construction. Contractor shall be responsible for the cost of repair of any such damage caused by Contractor or its agents or subagents.

*Qualifications of Contractor:*

1. Only proposals received from qualified FL licensed contractors will be considered. Responding contractors must provide proof of such qualifications in their response to this Invitation to Bid.

*Reference Drawings, Specifications, and Other:*

1. Design drawings by Poly Inc. referred to as “Appendix” and consisting of:
  - a. Cover Sheet - G1.0
  - b. Sheet 1 – G1.1
  - c. Sheet 2 – A1.0
  - d. Sheet 3 – A1.1
  - e. Sheet 4 – A1.2
  - f. Sheet 5 – S1.1
  - g. Sheet 6 – E1.0
2. Technical Specifications – included on Drawing sheets listed above
3. Contract Documents
  - a. Section 00300 – Quote Schedule
  - b. Section 00500 – Engineers Joint Contract Documents Committee (EJCDC) Standard Form Contract
  - c. Section 00610 – Performance Bond
  - d. Section 00620 – Payment Bond
  - e. Section 00700 – EJCDC General Conditions
  - f. Section 00800 – Supplementary General Conditions
  - g. Section 00810 – Special Conditions

The CRA reserves the right to waive technicalities or irregularities, to reject any or all bids, and to accept that bid which is in the best interest of the CRA. The Crestview Redevelopment Agency, a dependent special district for the City of Crestview, Florida, does not discriminate on the basis of race, color, national origin, sex, religion, age, and handicapped status in employment or provision of services.

September 28, 2018

**Report of Geotechnical Exploration  
City of Crestview Signs  
Crestview, Florida  
LMJ File # 18-347 E**

**Ms. Beth Brant, PE  
Poly Inc.  
P.O. Box 841  
Shalimar, FL 32575**



**Since 1976**

Geotechnical Engineering  
Drilling Services  
Materials Testing

**Larry M. Jacobs  
& Associates**

328 E Gadsden St  
Pensacola, FL 32501

**850.434.0846**

[www.lmj-a.com](http://www.lmj-a.com)

## TABLE OF CONTENTS

1.0 INTRODUCTION .....	1
2.0 SITE AND PROJECT CONDITIONS.....	1
3.0 SUBSURFACE EXPLORATION .....	1
4.0 SUBSURFACE CONDITIONS .....	1
5.0 LABORATORY TEST RESULTS .....	2
6.0 DISCUSSION AND RECOMMENDATIONS.....	2
6.1 Basis of Recommendations.....	2
6.2 General Summary .....	2
6.3 Site Preparation Recommendations .....	3
6.4 Fill Recommendations.....	3
6.5 Foundation Recommendations .....	3
Table #1: Allowable Soil Bearing Pressures .....	3
Figure #1: Boring Logs and Boring Location Plan .....	5



## 1.0 INTRODUCTION

This report forwards the results of our geotechnical exploration for the proposed **City of Crestview Signs** in Crestview, Florida. The purpose of this exploration was to determine the general subsurface conditions in the proposed sign areas and use this information to provide recommendations for earthwork and foundation design. Our exploration consisted of four Standard Penetration Test (SPT) borings, classification of the samples from the borings, laboratory testing of selected samples, and analysis by our engineering staff.

## 2.0 SITE AND PROJECT CONDITIONS

There are three proposed signs for this project: an arched gateway sign, a tower sign, and a gateway planter sign. The arch gateway sign is planned at the west end of N main Street near the intersection with Highway 90. The tower sign is planned at the southwest corner of the intersection of Courthouse Terrace and E James Lee Blvd (Hwy 90). The planter sign is planned at the intersection of S Main Street and S Ferdon Blvd about 150 feet north of the intersection. We understand that the arched gateway sign posts are planned where the existing concrete poles are at the west end of N Main street, and this area was occupied by grassed landscaped islands with bushes and small trees at the time of drilling. The other two sign areas were grassed at the time of drilling.

The arched gateway sign is planned to be constructed using CMU columns and a steel arch, and the other two signs are planned to be constructed using CMU. All of the signs are planned to be supported on a concrete footing. At the time of this report, specific structural loading information for the signs was not available. Should this information change or be incorrect, the geotechnical engineer should be notified and changes to our recommendations may be needed.

## 3.0 SUBSURFACE EXPLORATION

Our exploration included four Standard Penetration Test (SPT) borings drilled to depths of 17-21 feet below existing grade at the time of drilling. The SPT consists of driving a 2-inch diameter split spoon sampler into the ground using a 140-pound hammer dropped 30-inches. The number of blows required to drive the sampler one foot after seating it 6-inches is referred to as the blow count or "N" value which is a measure of soil density. "N" values can be found in **Figure #1** adjacent to the soil descriptions. Five SPT samples were collected in the top 10 feet, and the borings were sampled at five-foot intervals thereafter. The borings were drilled in general accordance with ASTM D1586 using truck mounted drill rigs. The boreholes were advanced between SPT sampling using solid stem flight auger. Each sample was removed from the sampler, classified in the field by the driller, and packaged for visual classification by our engineering staff and for laboratory testing. Note that boring B-4, drilled for the gateway planter sign, encountered an obstruction at 17 feet that could not be augered past, and this boring was therefore terminated at 17 feet.

## 4.0 SUBSURFACE CONDITIONS

The boring locations, and the subsurface conditions encountered in the borings are shown on the attached **Figure #1**. The borings were located in the field using existing site features, and all boring locations should be considered approximate. Boundaries between soil layers and soil depths should also be considered approximate since the actual transition between layers may be gradual. A



generalized summary of the conditions encountered in the borings is included below. The detailed conditions encountered in the borings are shown in the boring logs attached as **Figure #1**.

The borings generally encountered 3-6 inches of topsoil or asphalt over tan/orange silty sand and slightly silty sand to 6-8 feet underlain by red/orange silty sand with some trace clay to the bottom of the borings at 17-21 feet. An exception to this general soil summary is B-3, where a 3-inch layer of asphalt was encountered under 6 inches of topsoil underlain by tan/orange clayey silty sand to 1.5 feet. Soil density varied with boring locations. The arched gateway and gateway planter sign borings (B-1, B-2, and B-4) encountered loose and medium dense soils, except for the upper 2 feet of B-1, where dense conditions were encountered. The tower sign boring (B-3) encountered loose and medium dense soils in the upper 4 feet, very loose soils to roughly 13 feet and medium dense soils to the bottom of B-3 at 21 feet.

Groundwater was not encountered in the 17 to 21-foot borings at the time of drilling. Groundwater levels will vary with changes in rainfall and site drainage characteristics and may be different at other times. Although not encountered at the time of drilling, the borings did encounter conditions that may trap or perch infiltrating stormwater at or above 6-8 feet.

## **5.0 LABORATORY TEST RESULTS**

Laboratory testing for this project consisted of basic properties tests including wash #200 sieve and natural moisture content tests to assist in soil classification and to evaluate and document basic properties. Results of the laboratory tests are shown on the boring logs (**Figure #1**) adjacent to the samples tested.

## **6.0 DISCUSSION AND RECOMMENDATIONS**

### **6.1 Basis of Recommendations**

Recommendations rendered herein are based on assumed and/or design information available at the time of this report, the subsurface conditions encountered in the test borings, commonly accepted geotechnical engineering principles and practices, and our experience with similar soil and groundwater conditions. Should final project information or existing conditions differ from the information used in this report, or should any soil conditions not discussed in this report be encountered during construction, our office should be notified and retained so that this report can be modified as needed. In addition, LMJ should be provided with the final plans for review to determine if any changes to our report are needed based on the final design.

Regardless of the care exercised in performing a geotechnical exploration, the possibility always exists that soil and/or groundwater conditions will differ from those encountered at the specific boring locations. In addition, construction operations may alter the soil conditions. Therefore, it is recommended that a representative from Larry M. Jacobs & Associates, Inc. (LMJ) be involved during the construction phases discussed in this report. Note that LMJ cannot be responsible for the misinterpretation of the recommendations in this report.

### **6.2 General Summary**

The conditions encountered in the borings are suitable for the support of the planned signs. The different sign locations encountered different soil densities; therefore, the allowable bearing pressure will be different for each sign. The following sections outline our recommendations for site preparation and foundation design.





### 6.3 Site Preparation Recommendations

The existing ground surface in the sign areas should be cleared and stripped of all vegetation, major root systems, topsoil, and any other deleterious materials. After clearing and stripping, the sites can be excavated down to the bottom of footing elevation. Note that B-3 encountered a buried asphalt layer, and if additional debris is encountered at this location, it should be completely removed and replaced up to the bottom of footing elevation with soil compacted in accordance with the following section.

### 6.4 Fill Recommendations

Specific grading information was not available at the time of this report. If any imported fill is needed for this project we would recommend using slightly silty sand or silty sand soils free of significant organic content or other deleterious materials. All fill materials should be placed near their optimum moisture content in lifts compacted to a minimum of 95% of the Modified Proctor test (ASTM D1557) density. Lift thicknesses will depend on the fill material and equipment used, but hand operated equipment is anticipated for this project, and lift thicknesses of 6 inches are recommended for hand-operated equipment. The slightly silty sand to borderline silty sand soils encountered in the borings would be best compacted using a jumping jack compactor. Backfill for excavations made in the sign areas or adjacent to the signs, such as for the placement of utilities or foundations, should be placed and compacted in the same manner as fill.

### 6.5 Foundation Recommendations

The soils immediately beneath all footings should be compacted for a minimum depth of 12 inches to a minimum of 95% of the Modified Proctor test (ASTM D1557) density using a jumping jack compactor. We recommend verifying compaction using in place nuclear density testing with a minimum of one density test run for each footing. The bottom of all footings should be evaluated by LMJ staff prior to the placement of concrete or steel.

As previously mentioned, the borings encountered erratic soil densities, and the allowable bearing pressure will be different for each sign. Assuming that the sign foundations are prepared in accordance with this report, the signs can be designed for the allowable net soil bearing pressures in the following **Table #1**. We have assumed a bottom of footing depth of roughly 3-4 feet below existing grade and footing widths of 6-9 feet for the signs. Our office should be contacted if these assumptions are not correct.

**Table #1: Allowable Soil Bearing Pressures**

Sign	Boring	Net Allowable Bearing Pressure (psf)
Arched Gateway	B-1 & B-2	2,000
Tower Sign	B-3	1,000
Gateway Planter	B-4	3,000

We estimate settlement from the sand soils immediately beneath the footings to be 1 inch or less at the allowable bearing pressures in **Table #1**. This settlement should occur during construction and soon after initial loading. The allowable bearing pressures are controlled by settlement. The tower sign boring (B-3) encountered very loose conditions, and if a higher allowable bearing pressure is needed for this sign, it could be achieved by undercutting the very loose soils and



replacing them in compacted lifts under the sign. Our office should be contacted if a higher allowable bearing pressure is needed so we can provide specific undercutting recommendations.

We hope that this report provides sufficient information for your current requirements. If you have any questions or comments, please do not hesitate to call.

Respectfully yours,

**LARRY M. JACOBS & ASSOCIATES, INC.**

A handwritten signature in blue ink, appearing to read 'Keith V. Jacobs', with a horizontal line extending to the right towards the professional seal.

Keith V. Jacobs, PE  
Project Engineer  
Florida Reg. #66577

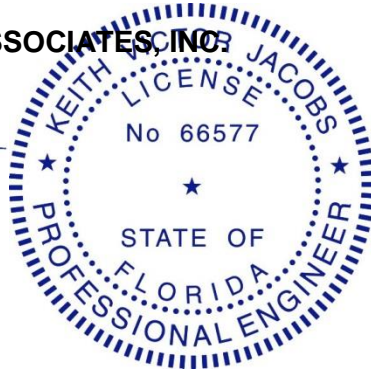

This document has been digitally signed by Keith V, Jacobs, PE. Printed copies of this document are not considered signed and sealed, and the signature must be verified on any electronic copies.  
2018-09-28

Attachments

# BORING LOGS

## BORING LOCATION PLAN

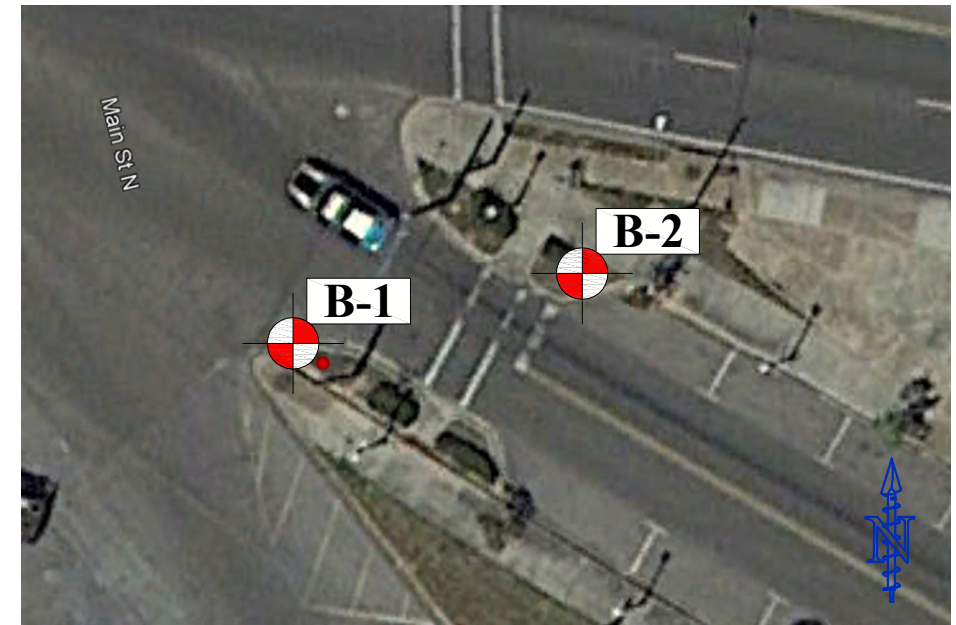

### ARCHED GATEWAY SIGN

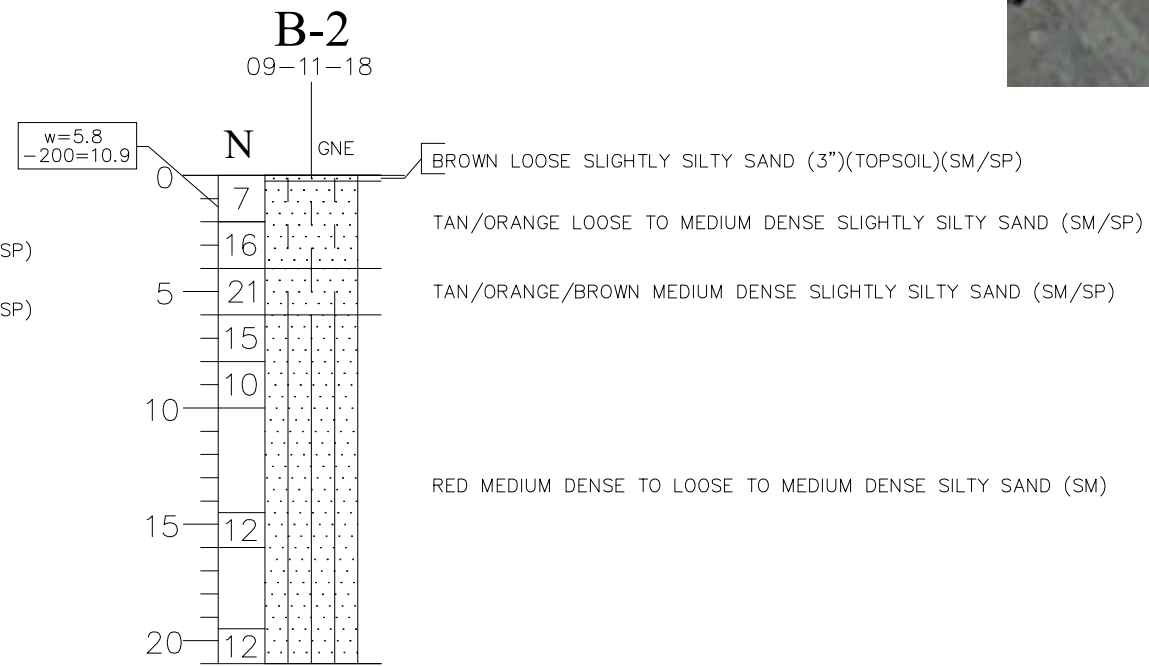
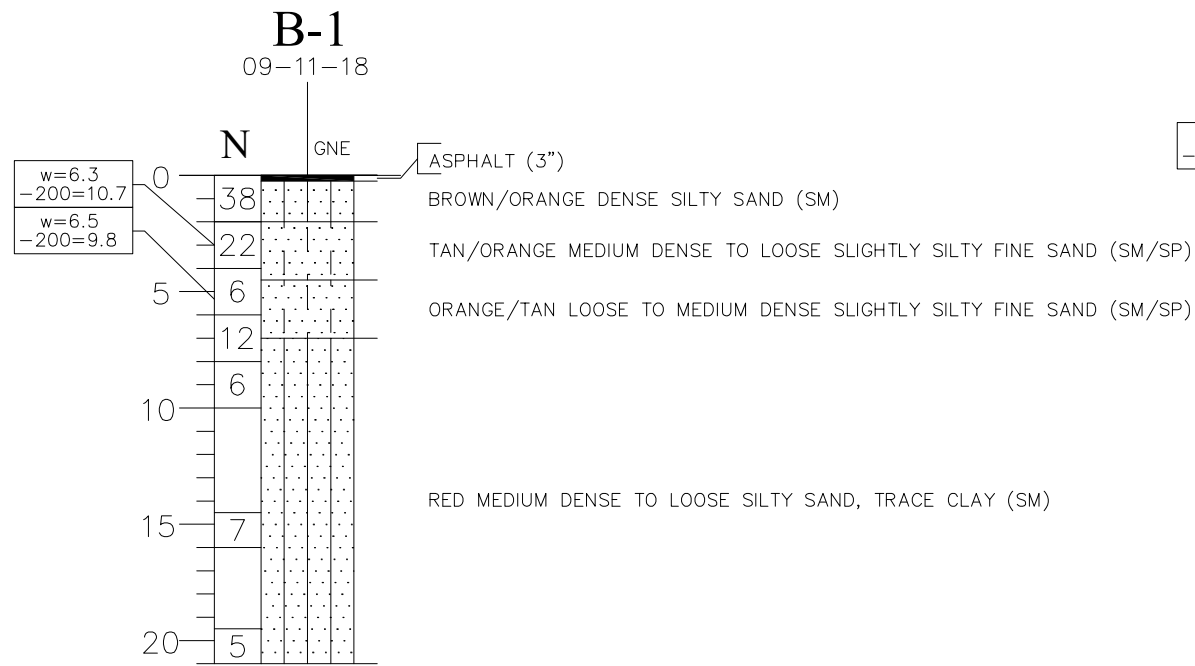

Project #: 18-347 Scale: NTS

Date: 09/28/2018 Checked By: KVJ

Project: City of Crestview Signs

Location: Crestview, Florida



# BORING LOGS

## TOWER SIGN

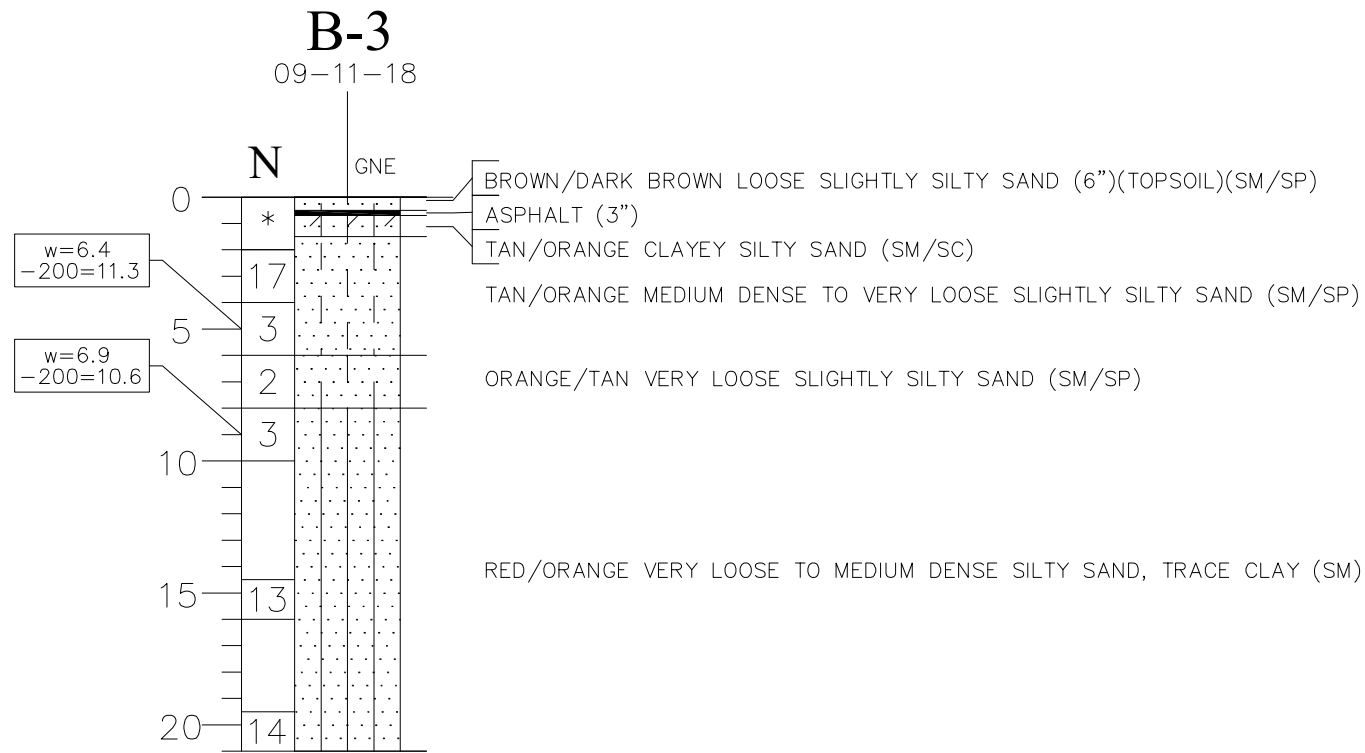

\*HAMMER BLOWS:  
 \* FT SAMPLE: 4/6"

## GATEWAY PLANTER SIGN

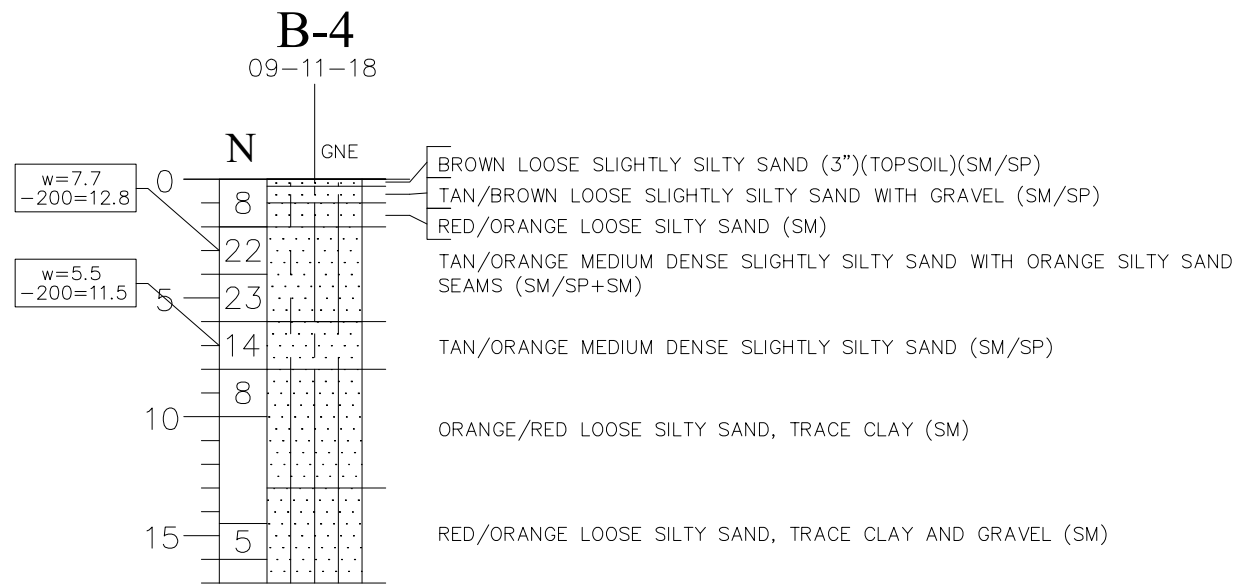

NOTE: ENCOUNTERED OBSTRUCTION AT 17 FT,  
 TRACE BLACK ORGANICS IN 8-10 FT SAMPLE

# BORING LOCATION PLAN



Project #: 18-347 Scale: NTS

Date: 09/28/2018 Checked By: KVJ

Project: City of Crestview Signs

Location: Crestview, Florida



QUOTE SCHEDULE

QUOTE SCHEDULE – CRA GATEWAY SIGNAGE (MONUMENT SIGNAGE)

NOTE: QUOTES MUST INCLUDE SALES TAX AND ALL OTHER APPLICABLE TAXES AND FEES.

<u>ITEM NO.</u>	<u>EST. QTY. AND UNIT</u>	<u>DESCRIPTION</u>	<u>UNIT PRICE</u>	<u>TOTAL</u>
1	1 LS	Mobilization, demobilization, bond, insurance, etc., obtained and in effect	\$ _____	\$ _____
2	1 LS	Provide and install all materials and labor needed to construct new brick planter sign as described in the specifications, constructed completely and in place for the lump sum amount of	\$ _____	\$ _____
<b><u>TOTAL QUOTE</u></b>			<b>\$ _____</b>	

**TOTAL BASE QUOTE AMOUNT IS** \_\_\_\_\_  
\_\_\_\_\_.

Unit Prices have been computed in accordance with paragraph 11.03.B of the General Conditions Section 00700 to this bid invitation.

QUOTER acknowledges that estimated quantities are not guaranteed and are solely for the purpose of comparison of bids and final cost will be based on actual quantities of materials and labor needed to build the structure as described in the Contract Documents.

QUOTER agrees that the Work will be Substantially Completed within sixty (60) calendar days after the date when the Contract Times commence to run as described in paragraph 2.03 of the General Conditions and all work will be completed and ready for final inspection and payment in accordance with the paragraph 14.07.B of the General Conditions within One Hundred Twenty (120) calendar days after the date when the Contract Times commence to run.

QUOTER accepts the provisions of the Agreement as to liquidated damages in the event of failure to complete the Work within the times specified above, which shall be stated in the Agreement.

The defined terms used in this Quote Schedule (words with initial capital letters) have the meanings stated in the General Conditions and the Supplementary Conditions. The terms "Quote" and "Bid" and their derivatives are intended to have the same meaning.

By signing below, QUOTER certifies that, as provided in Fl. St. 287.132-133, that neither it, nor its affiliates, contractors, sub-contractors or agents who will perform Work on the Project, have been placed on the Convicted Vendor List maintained by the State of Florida Department of Management Services within thirty-six (36) months immediately preceding the execution date, below.

SUBMITTED ON \_\_\_\_\_, 2019.

State Contractor License No. \_\_\_\_\_ (If applicable)

**IF QUOTER IS:**

**An Individual**

Name (typed or printed): \_\_\_\_\_

By: \_\_\_\_\_  
(Individual's signature)

Doing business as: \_\_\_\_\_

Business address: \_\_\_\_\_

\_\_\_\_\_

Phone No.: \_\_\_\_\_ FAX No. \_\_\_\_\_

**A Partnership**

Partnership Name: \_\_\_\_\_

By \_\_\_\_\_  
(Signature of general partner)

Name (typed or printed): \_\_\_\_\_

Business address: \_\_\_\_\_

\_\_\_\_\_

Phone No.: \_\_\_\_\_ FAX No. \_\_\_\_\_

**A Corporation**

Corporation Name: \_\_\_\_\_

State of Incorporation: \_\_\_\_\_

By: \_\_\_\_\_  
(Signature Of Person Authorized To Sign)

Name (typed or printed): \_\_\_\_\_

Title: \_\_\_\_\_

(CORPORATE SEAL)

Attest \_\_\_\_\_  
(Signature of Corporate Secretary)

Business address: \_\_\_\_\_

\_\_\_\_\_

Phone No.: \_\_\_\_\_ FAX No.: \_\_\_\_\_

Date of Qualification to do business is \_\_\_\_\_

**A Joint Venture**

Joint Venturer Names: \_\_\_\_\_

By: \_\_\_\_\_  
(Signature of joint venture partner)

Name (typed or printed): \_\_\_\_\_

Title: \_\_\_\_\_

Business address: \_\_\_\_\_

\_\_\_\_\_

Phone No.: \_\_\_\_\_ FAX No.: \_\_\_\_\_

Joint Venturer Name: \_\_\_\_\_

By: \_\_\_\_\_  
(Signature)

Name (typed or printed): \_\_\_\_\_

Title: \_\_\_\_\_

Business address: \_\_\_\_\_

\_\_\_\_\_

Phone No.: \_\_\_\_\_ FAX No.: \_\_\_\_\_

Phone and FAX number, and address for receipt of official communications:

\_\_\_\_\_

\_\_\_\_\_

(Each joint venturer must sign. The manner of signing for each individual, partnership, and corporation that is a party to the joint venture shall be in the manner indicated above.)



ATTACHMENT "A"

CONFLICT OF INTEREST DISCLOSURE FORM

For purposes of determining any possible conflict of interest, all QUOTERS/bidders must disclose if any person \_\_\_\_\_, employee(s), elected official(s), or if any of its' agencies is also an owner, corporate officer, agency, employee, etc., of their business.

Indicate either "YES" (a City of Crestview employee, elected official, or agency is also associated with your business), or "NO". If yes, give person's name(s) and position(s) with your business.

YES \_\_\_\_\_

NO \_\_\_\_\_

NAME(S) and POSITION(S):

\_\_\_\_\_  
\_\_\_\_\_  
\_\_\_\_\_  
\_\_\_\_\_

FIRM NAME: \_\_\_\_\_

BY (printed): \_\_\_\_\_

BY (signature): \_\_\_\_\_

TITLE: \_\_\_\_\_

ADDRESS: \_\_\_\_\_

PHONE: \_\_\_\_\_

ATTACHMENT "B"

## INDEMNIFICATION AND HOLD HARMLESS

To the fullest extent permitted by law, CONTRACTOR (also referred to herein as "QUOTER") shall indemnify and hold harmless the OWNER, the Crestview CRA, the City of Crestview, their officers, agents and employees from liabilities, damages, losses, and costs including but not limited to reasonable attorney fees, to the extent caused by the negligence, recklessness, or intentionally wrongful conduct of the CONTRACTOR and other persons employed or utilized by the CONTRACTOR in the performance of this Agreement.

\_\_\_\_\_  
QUOTER's Company Name

\_\_\_\_\_  
Authorized Signature - Manual

\_\_\_\_\_  
Physical Address

\_\_\_\_\_  
Authorized Signature - Typed

\_\_\_\_\_  
Mailing Address

\_\_\_\_\_  
Title

\_\_\_\_\_  
Phone Number

\_\_\_\_\_  
FAX Number

\_\_\_\_\_  
Cellular Number

\_\_\_\_\_  
After-Hours Number(s)

\_\_\_\_\_  
Date

(REVISED: JANUARY 12, 2001)

ATTACHMENT "C"

**INSURANCE COMPLIANCE**

This form is to be completed and signed by QUOTER certifying that your policy meets the insurance requirements as specified in the Supplementary Conditions, 00800 at pages 00800-3 and 00800-04, Quote No. \_\_\_\_\_, and that your insurance company has reviewed the bid requirements and certifies that you were quoted any price increase due to required coverage and such increase is acceptable to QUOTER.

**CONTRACTOR**

I certify that the insurance requirements have been reviewed.

**Company Name**

\_\_\_\_\_

Address

\_\_\_\_\_

\_\_\_\_\_

**Representative**

Name

\_\_\_\_\_

Title

\_\_\_\_\_

Phone Number

\_\_\_\_\_

END OF SECTION 00300

SECTION 00500

EJCDC  
STANDARD FORM OF AGREEMENT  
BETWEEN OWNER AND CONTRACTOR  
ON THE BASIS OF A STIPULATED PRICE

THIS AGREEMENT is by and between City of Crestview Community Redevelopment Agency,  
(hereinafter called OWNER or CRA) and \_\_\_\_\_  
(hereinafter called CONTRACTOR). OWNER and CONTRACTOR, in consideration of the  
mutual covenants hereinafter set forth, agree as follows:

**ARTICLE 1. WORK**

1.01 CONTRACTOR shall complete all Work as specified or indicated in the Contract Documents. The Work is generally described as follows:

CRA Gateway Signage (Monument Sign)

**ARTICLE 2 - THE PROJECT**

2.01 The Project for which the Work under the Contract Documents may be the whole or only a part is generally described as follows and more specifically described in the Scope of Work and Project Drawings:

CRA Gateway Signage (Monument Sign)

**ARTICLE 3 - ENGINEER**

3.01 The Project has been designed by POLY, INC. who is hereinafter called ENGINEER and who is to act on OWNER's behalf, assume all duties and responsibilities and have the rights and authority assigned to ENGINEER in the Contract Documents in connection with completion of the Work in accordance with the Contract Documents.

**ARTICLE 4 - CONTRACT TIME**

4.01 Time of the Essence

A. All time limits for Milestones, if any, Substantial Completion, and completion and readiness for final payment as stated in the Contract Documents are of the essence of the Contract.

4.02 Days to Achieve Substantial Completion and Final Payment

A. The Work will be substantially completed within **60** calendar days from the date when the Contract Time commences to run as provided in paragraph 2.03 of the General

Conditions, and completed and ready for final payment in accordance with paragraph 14.07.B of the General Conditions within **120** calendar days from the date when the Contract Time commences to run.

#### 4.03 Liquidated Damages.

- A. **Amount:** In case of failure on the part of the Contractor to complete the Work within the time(s) specified in paragraph 4.02 above, or within such additional time(s) as may be granted in writing by the CRA in accordance with Article 12 of the General Conditions, CRA will suffer damage, the amount of which is difficult, if not impossible, to ascertain. Therefore, the Contractor shall pay to the CRA, as liquidated damages, the amount of \$250 for each calendar day of delay that actual completion extends beyond the time limit specified until such reasonable time as may be required for final completion of the work. In no way shall costs for liquidated damages be construed as penalty on the Contractor.
- B. **Determination of Number of Days of Default:** For all contracts, regardless of whether the contract time is stipulated in calendar days or working days, the default days shall be counted in calendar days.
- C. **Conditions under which Liquidated Damages are imposed:** Should the Contractor or, in case of his default, the Surety, fail to complete the work within the time stipulated in paragraph 4.02 above, or within such extra time as may have been granted by the CRA in accordance with Article 12 of the General Conditions, the Contractor or, in case of his default, the Surety, shall pay to the CRA, not as a penalty, but as liquidated damages by agreement, the amount so due as determined by the Code requirements, as provided above.
- D. **Right of Collection:** The CRA shall have the right to apply as payment on such liquidated damages any money which is due to the Contractor by the CRA.
- E. **Permitting Contractor to Finish Work:** Permitting the Contractor to continue and to finish the work, or any part of it, after the expiration of the Contract Time allowed, including extensions of time granted to the Contractor, shall in no way act as a waiver on the part of the CRA the liquidated damages due under the contract.
- F. **Completion of Work by CRA:** In case of default of the contract and the completion of the Work by the CRA, the Contractor and his Surety shall be liable for the liquidated damages under the contract, but no liquidated damages shall be chargeable for any delay in the final completion of the Work caused directly from any unreasonable action or delay on the part of the CRA.

## ARTICLE 5 - CONTRACT PRICE

5.01 OWNER shall pay CONTRACTOR for completion of the Work in accordance with the Contract Documents an amount in current funds equal to the sum of the amounts determined pursuant to paragraphs 5.01.A below:

- A. For all Work, at the prices stated in CONTRACTOR's Quote, attached hereto in Section 00300.

As provided in paragraph 11.03 of the General Conditions, estimated quantities are not guaranteed, and determinations of actual quantities and classifications are to be made by ENGINEER as provided in paragraph 9.08 of the General Conditions. Unit prices have been computed as provided in paragraph 11.03 of the General Conditions.

Contract Amount of \_\_\_\_\_

## **ARTICLE 6 - PAYMENT PROCEDURES**

### **6.01 Submittal and Processing of Payments**

A. CONTRACTOR shall submit Applications for Payment in accordance with Article 14 of the General Conditions. Applications for Payment will be processed by ENGINEER as provided in the General Conditions.

### **6.02 Progress Payments; Retainage**

A. OWNER shall make progress payments on account of the Contract Price on the basis of CONTRACTOR's Applications for Payment on or about the 10th day of each month during performance of the Work as provided in Paragraphs 6.02.A.1 and 6.02.A.2 below. All such payments will be made in accordance with this Section 6.02 and the process outlined in the General and Supplementary Conditions.

1. Prior to Substantial Completion, progress payments will be made in an amount equal to the percentage indicated below, but, in each case, less the aggregate of payments previously made and less such amounts as ENGINEER shall determine, or OWNER may withhold, in accordance with paragraph 14.02 of the General Conditions.

a. Ninety percent (90%) of Work completed (with the balance being retainage). If Work has been fifty percent (50%) completed as determined by ENGINEER, and if the character and progress of the Work have been satisfactory to OWNER and ENGINEER, OWNER on recommendation of ENGINEER, may determine that as long as the character and progress of the Work remain satisfactory to them, there will be no retainage on account of Work subsequently completed, in which case the remaining progress payments prior to Substantial Completion will be in an amount equal to 100% of the Work completed less the aggregate of payments previously made; and

b. Ninety percent (90%) of cost of materials and equipment not incorporated in the Work (with the balance being retainage).

2. Upon Substantial Completion, OWNER shall pay an amount sufficient to increase total payments to CONTRACTOR to ninety-five percent (95%) of the Work completed, less such amounts as ENGINEER shall determine in accordance with paragraph 14.02.B.5 of the General Conditions and less 100% of ENGINEER's estimate of the value of Work to be completed or corrected as shown on the tentative list of items to be completed or corrected attached to the certificate of Substantial Completion.

### 6.03 Final Payment.

A. Upon final completion and acceptance of the Work in accordance with paragraph 14.07 of the General Conditions, OWNER shall pay the remainder of the Contract Price as recommended by ENGINEER as provided in said paragraph 14.07.

## **ARTICLE 7 - INTEREST**

7.01 All moneys not paid when due as provided in Article 14 of the General Conditions shall bear interest at the rate of 5% per annum.

## **ARTICLE 8 - CONTRACTOR'S REPRESENTATIONS**

8.01 In order to induce OWNER to enter into this Agreement CONTRACTOR makes the following representations:

A. CONTRACTOR has examined and carefully studied the Contract Documents and the other related data identified in the Invitation to Bid.

B. CONTRACTOR has visited the site and become familiar with and is satisfied as to the general, local and site conditions that may affect cost, progress, performance of the Work.

C. CONTRACTOR is familiar with and is satisfied as to all federal, state and local Laws and Regulations that may affect cost, progress, performance of the Work.

D. CONTRACTOR has carefully studied all: (1) reports of explorations and tests of subsurface conditions at or contiguous to the Site and all drawings of physical conditions in or relating to existing surface or subsurface structures at or contiguous to the Site (except Underground Facilities) which have been identified in the Supplementary Conditions as provided in paragraph 4.02 of the General Conditions and (2) reports and drawings of a Hazardous Environmental Condition, if any, at the Site which has been identified in the Supplementary Conditions as provided in paragraph 4.06 of the General Conditions.

E. CONTRACTOR has obtained and carefully studied (or assumes responsibility for having done so) all additional or supplementary examinations, investigations, explorations, tests, studies, and data concerning conditions (surface, subsurface, and Underground Facilities) at or contiguous to the Site which may affect cost, progress, or performance of the Work or which relate to any aspect of the means, methods, techniques, sequences, and procedures of construction to be employed by CONTRACTOR, including applying the specific means, methods, techniques, sequences, and procedures of construction, if any, expressly required by the Contract Documents to be employed by CONTRACTOR, and safety precautions and programs incident thereto.

F. CONTRACTOR does not consider that any further examinations, investigations, tests, studies, or data are necessary for the performance of the Work at the Contract Price, within the Contract Times, and in accordance with the other terms and conditions of the Contract Documents.

G. CONTRACTOR is aware of the general nature of work to be performed by

OWNER and others at the Site that relates to the Work as indicated in the Contract Documents.

H. CONTRACTOR has correlated the information known to CONTRACTOR, information and observations obtained from visits to the Site, reports and drawings identified in the Contract Documents and all additional examinations, investigations, explorations, tests, studies, and data with the Contract Documents.

I. CONTRACTOR has given ENGINEER written notice of all conflicts, errors, ambiguities or discrepancies that CONTRACTOR has discovered in the Contract Documents and the written resolution thereof by ENGINEER is acceptable to CONTRACTOR

J. CONTRACTOR agrees that the Contract Documents are generally sufficient to indicate and convey sufficient understanding of all terms and conditions for performance and furnishing of the Work.

## ARTICLE 9 - CONTRACT DOCUMENTS

### 9.01 Contents

- A. The Contract Documents consist of the following:
1. This Agreement (pages 00500-1 to 00500-8, inclusive);
  2. Performance Bond (pages 00610-1 to 00610-2, inclusive);
  3. Payment Bond (pages 00620-1 to 00620-2, inclusive);
  4. General Conditions (pages 00700-1 to 00700-43, inclusive);
  5. Supplementary Conditions (pages 00800-1 to 00800-7, inclusive);
  6. Special Conditions (pages 00810-1 to 00810-9, inclusive);
  7. Specifications as included in the Design Drawings;
  8. Design Drawings (Sheets (G1.0-G1.1, A1.0-A1.2, S1.1, E1.0, inclusive));
  9. Addenda (numbers \_\_\_\_\_, inclusive);
  10. Exhibits to this Agreement (enumerated as follows):
    - a. Notice to Proceed (page \_\_\_\_\_ inclusive);
    - b. CONTRACTOR's Quote (pages \_\_\_\_\_ to \_\_\_\_\_, inclusive);
    - c. Documentation submitted by CONTRACTOR prior to Notice of Award (pages \_\_\_\_\_ to \_\_\_\_\_, inclusive);
    - d. \_\_\_\_\_
  11. The following which may be delivered or issued after the Effective Date of the Agreement and are not attached hereto:
    - a. Written Amendments;
    - b. Work Change Directives;
    - c. Change Order(s).
- B. The documents listed in paragraph 9.01.A are attached to this Agreement and by this reference are incorporated into this Agreement (except as expressly noted otherwise above).
- C. There are no Contract Documents other than those listed above in this Article 9.
- D. The Contract Documents may only be amended, modified, or supplemented as provided in paragraph 3.05 of the General Conditions.

## ARTICLE 10 - MISCELLANEOUS



## 10.01 Terms

A. Defined terms (capitalized terms) used in this Agreement will have the meanings stated in the General Conditions.

## 10.02 Assignment of Contract

A. No assignment by a party hereto of any rights or interests in the Contract will be binding on another party hereto without the written consent of the party sought to be bound; and, specifically but without limitation, moneys that may become due and moneys that are due may not be assigned without such consent (except to the extent that the effect of this restriction may be limited by law), and unless specifically stated to the contrary in any written consent to an assignment, no assignment will release or discharge the assignor from any duty or responsibility under the Contract Documents.

## 10.03 Successors and Assigns

A. OWNER and CONTRACTOR each binds itself, its partners, successors, assigns and legal representatives to the terms of this Agreement with respect to all covenants, agreements and obligations contained in the Contract Documents.

## 10.04 Severability

A. Any provision or part of the Contract Documents held to be void or unenforceable under any Laws or Regulations shall be deemed stricken, and all remaining provisions shall continue to be valid and binding upon OWNER and CONTRACTOR, who agree that the Contract Documents shall be reformed to replace such stricken provision or part thereof with a valid and enforceable provision that comes as close as possible to expressing the intention of the stricken provision.

## 11.01– Public Records.

CONTRACTOR shall comply with the requirements of Florida’s Public Records law. In accordance with Section 119.0701, Florida Statutes, CONTRACTOR shall:

- a. Keep and maintain public records required by the OWNER necessary to build and operate the Project.
- b. Upon request from the OWNER or City of Crestview’s custodian of public records, provide the OWNER with a copy of the requested records or allow the records to be inspected or copied within a reasonable time at a cost that does not exceed the cost provided under Florida’s Public Records Law or as otherwise provided by law.
- c. Ensure that public records that are exempt or confidential and exempt from public records disclosure requirements are not disclosed except as authorized by law for the duration of the contract term and following completion of this contract if CONTRACTOR does not transfer the records to the OWNER: and
- d. Upon completion of the contract, transfer, at no cost, to the OWNER all public records in possession of CONTRACTOR or keep and maintain public records required by the

OWNER to perform the service. If CONTRACTOR transfers all public records to the OWNER upon completion of the contract, CONTRACTOR shall destroy any duplicate public records that are exempt or confidential and exempt from public records disclosure requirements. If CONTRACTOR keeps and maintains public records upon completion of this contract, the CONTRACTOR shall meet all applicable requirements for retaining public records. All records stored electronically must be provided to the OWNER, upon request from public OWNER's custodian of public records, in a format that is compatible with the information technology systems of the OWNER.

- e. If CONTRACTOR has questions regarding the application of Chapter 119, Florida Statutes to CONTRACTOR's duty to provide public records relating to this Agreement, Developer shall contact the Custodian of Public Records at:**

**City Clerk, City of Crestview  
198 North Wilson Street  
P.O. Box 1209  
Crestview, Florida 32536  
(850) 682-1560 Extension 250  
[cityclerk@cityofcrestview.org](mailto:cityclerk@cityofcrestview.org)**

- f. In the event the OWNER must initiate litigation against CONTRACTOR in order to enforce compliance with Chapter 119, Florida Statutes, or in the event of litigation filed against the OWNER or City of Crestview because CONTRACTOR failed to provide access to public records responsive to a public record request, the OWNER shall be entitled to recover all costs, including but not limited to reasonable attorneys' fees for trial court and appellate court proceedings, costs of suit, witness, fees, and expert witness fees extended as part of said litigation and any subsequent appeals.

(The remainder of this page is intentionally blank)

IN WITNESS WHEREOF, OWNER and CONTRACTOR have signed this Agreement in triplicate. One counterpart each has been delivered to OWNER, CONTRACTOR and ENGINEER. All portions of the Contract Documents have been signed or identified by OWNER and CONTRACTOR or on their behalf.

This Agreement will be effective on \_\_\_\_\_, 2019 (which is the Effective Date of the Agreement).

OWNER  
CRESTVIEW COMMUNITY  
REDEVELOPMENT AGENCY

CONTRACTOR  
\_\_\_\_\_

By: \_\_\_\_\_  
CRA Chairman

By: \_\_\_\_\_

Attest  
Elizabeth Roy, CRA Administrator

Attest  
\_\_\_\_\_

Address for giving notices:  
198 Wilson Street North  
Crestview, FL 32536

Address for giving notices:  
\_\_\_\_\_  
\_\_\_\_\_

Designated Representative:  
Name: Alisa Burleson

License No. \_\_\_\_\_  
(Where Applicable)

Title: CRA Director

Agent for Service of Process: \_\_\_\_\_

Address: 198 Wilson Street North

Phone: \_\_\_\_\_

Designated Representative:

Facsimile: \_\_\_\_\_

Name: \_\_\_\_\_

Title: \_\_\_\_\_

Address: \_\_\_\_\_

Phone: \_\_\_\_\_

Facsimile: \_\_\_\_\_

END OF SECTION 00500

SECTION 00610

**PERFORMANCE BOND**

KNOW ALL MEN BY THESE PRESENTS: That we (1) \_\_\_\_\_  
a (2) \_\_\_\_\_ hereinafter called "Principal" and (3) \_\_\_\_\_  
of \_\_\_\_\_ State of \_\_\_\_\_ hereinafter called "Surety", are held  
and firmly bound unto (4) City of Crestview Community Redevelopment Agency hereinafter called  
"Owner", in the penal sum of \_\_\_\_\_  
(\$ \_\_\_\_\_), in lawful money of the United States, for the payment of which sum well and  
truly to be made, we bind ourselves, our heirs, executors, administrators and successors, jointly and  
severally firmly by these presents:

THE CONDITION OF THIS OBLIGATION is such that Whereas, the Principal entered into a  
certain contract with the Owner, dated the \_\_\_\_\_ day of \_\_\_\_\_, 2019, a copy of  
which is hereto attached and made a part hereof for the construction of:

CRA Gateway Signage (Monument sign)

NOW, THEREFORE, if the Principal shall well, truly and faithfully perform its duties, all the  
undertakings, covenants, terms, conditions and agreements of said contract during the original term  
thereof, and any extensions thereof which may be granted by the Owner, with or without notice to the  
Surety, and if he shall satisfy all claims and demands incurred under such contract, and shall fully  
indemnify and save harmless the Owner from all costs and damages which it may suffer by reason of  
failure to do so, and shall reimburse and repay the Owner all outlay and expense which the Owner may  
incur in making good any default, then this obligation shall be void; otherwise to remain in full force and  
effect.

PROVIDED, FURTHER, that the said Surety, for value received hereby stipulates and agrees that  
no charges, extension of time, alteration or addition to the terms of the contract or to the work to be  
performed thereunder or the Specifications accompanying the same shall in any way affect its obligations  
on this bond, and it does hereby waive notice of any such change, extension of time, alteration or addition  
to the terms of the contract or to the work or to the Specifications.

PROVIDED, FURTHER, that no final settlement between the Owner and the Contractor shall  
abridge the right of any beneficiary hereunder, whose claim may be unsatisfied.

IN WITNESS WHEREOF, this instrument is executed in three (3) counterparts, each one of which shall be deemed an original, this the \_\_\_\_\_ day of \_\_\_\_\_, 2019.

ATTEST:

\_\_\_\_\_  
Principal

\_\_\_\_\_  
(Principal) Secretary

By \_\_\_\_\_ /s/

\_\_\_\_\_  
(Witness as to Principal)

\_\_\_\_\_  
(Address)

\_\_\_\_\_  
(Address)

ATTEST:

\_\_\_\_\_  
Surety

\_\_\_\_\_  
(Surety) Secretary

By \_\_\_\_\_ /S/  
Attorney-in-Fact

\_\_\_\_\_  
Witness as to Surety

\_\_\_\_\_  
(Address)

\_\_\_\_\_  
(Address)

NOTE: Date of Bond must not be prior to date of Contract.

- (1) Correct name of Contractor.
- (2) A Corporation, A Partnership or an Individual as case may be.
- (3) Correct name of Surety.
- (4) Correct name of Owner.
- (5) If Contractor is Partnership, all partners should execute bond.

END OF SECTION 00610

SECTION 00620

**PAYMENT BOND**

KNOW ALL MEN BY THESE PRESENTS: That we (1) \_\_\_\_\_  
a (2) \_\_\_\_\_ hereinafter called "Principal" and (3) \_\_\_\_\_  
of \_\_\_\_\_ State of \_\_\_\_\_ hereinafter called "Surety", are held  
and firmly bound unto (4) City of Crestview Community Redevelopment Agency hereinafter called  
"Owner", in the penal sum of \_\_\_\_\_  
(\$ \_\_\_\_\_), in lawful money of the United States, for the payment of which sum well and  
truly to be made, we bind ourselves, our heirs, executors, administrators and successors, jointly and  
severally firmly by these presents:

THE CONDITION OF THIS OBLIGATION is such that Whereas, the Principal entered into a certain  
contract with the Owner, dated the \_\_\_\_\_ day of \_\_\_\_\_, 2019, a copy of which is hereto  
attached and made a part hereof for the construction of:

CRA Gateway Signage (Monument sign)

NOW, THEREFORE, if the Principal shall promptly make payments to all persons, firms,  
subcontractors, and corporations furnishing materials for or performing labor in the prosecution of the  
work provided for in such contract, and any authorized extension or modification thereof, including all  
amounts due for materials, lubricants, oil, gasoline, coal and coke, repairs on machinery, equipment and  
tools, consumed or used in connection with the construction of such work, and all insurance premiums on  
said work, and for all labor, performed in such work, whether by subcontractor or otherwise, then this  
obligation shall be void; otherwise to remain in full force and effect.

PROVIDED, FURTHER, that the said surety, for value received hereby stipulates and agrees that no  
change, extension of time, alteration or addition to the terms of the contract or to the work to be in any  
wise affect its obligation on this bond, and it does hereby waive notice of any such changes, extension of  
time, alteration or addition to the terms of the contractor or to the work or to the Specifications.

PROVIDED, FURTHER, that no final settlement between the Owner and the Contractor shall abridge  
the right of any beneficiary hereunder, whose claim may be unsatisfied.

IN WITNESS WHEREOF, this instrument is executed in three (3) counterparts, each one of which shall be deemed in original, this the \_\_\_\_\_ day of \_\_\_\_\_, 2019.

ATTEST:

\_\_\_\_\_  
Principal

\_\_\_\_\_  
(Principal) Secretary

By \_\_\_\_\_ /s/

\_\_\_\_\_  
(Witness as to Principal)

\_\_\_\_\_  
(Address)

\_\_\_\_\_  
(Address)

ATTEST:

\_\_\_\_\_  
Surety

\_\_\_\_\_  
(Surety) Secretary

By \_\_\_\_\_ /s/

Attorney-in-Fact

\_\_\_\_\_  
Witness as to Surety

\_\_\_\_\_  
(Address)

\_\_\_\_\_  
(Address)

NOTE: Date of Bond must not be prior to date of contract.

- (1) Correct name of Contractor
- (2) A Corporation, a Partnership, or an Individual, as case may be.
- (3) Correct Name of Surety.
- (4) Correct Name of Owner.
- (5) If Contractor is Partnership, all partners should execute bond.

END OF SECTION 00620

This document has important legal consequences; consultation with an attorney is encouraged with respect to its use or modification. This document should be adapted to the particular circumstances of the contemplated Project and the Controlling Law.

# STANDARD GENERAL CONDITIONS OF THE CONSTRUCTION CONTRACT

Prepared by

**ENGINEERS JOINT CONTRACT DOCUMENTS COMMITTEE**

and

Issued and Published Jointly By



AMERICAN CONSULTING  
ENGINEERS COUNCIL



PROFESSIONAL ENGINEERS IN PRIVATE PRACTICE  
*a practice division of the*  
NATIONAL SOCIETY OF PROFESSIONAL ENGINEERS

AMERICAN CONSULTING ENGINEERS COUNCIL

AMERICAN SOCIETY OF CIVIL ENGINEERS

This document has been approved and endorsed by

The Associated General



Contractors of America

Construction Specifications Institute



These General Conditions have been prepared for use with the Owner-Contractor Agreements (No. 1910-8-A-1 or 1910-8-A-2) (1996 Editions). Their provisions are interrelated and a change in one may necessitate a change in the other. Comments concerning their usage are contained in the EJCDC User's Guide (No. 1910-50). For guidance in the preparation of Supplementary Conditions, see Guide to the Preparation of Supplementary Conditions (No. 1910-17) (1996 Edition).



Copyright ©1996

National Society of Professional Engineers  
1420 King Street, Alexandria, VA 22314

American Consulting Engineers Council  
1015 15th Street N.W., Washington, DC 20005

American Society of Civil Engineers  
345 East 47th Street, New York, NY 10017

TABLE OF CONTENTS

Page

ARTICLE 1 - DEFINITIONS AND TERMINOLOGY .....6  
1.01 *Defined Terms* .....6  
1.02 *Terminology*.....8

ARTICLE 2 - PRELIMINARY MATTERS .....9  
2.01 *Delivery of Bonds* .....9  
2.02 *Copies of Documents*.....9  
2.03 *Commencement of Contract Times; Notice to Proceed* .....9  
2.04 *Starting the Work* .....9  
2.05 *Before Starting Construction* .....9  
2.06 *Preconstruction Conference* .....10  
2.07 *Initial Acceptance of Schedules* .....10

ARTICLE 3 - CONTRACT DOCUMENTS: INTENT, AMENDING, REUSE .....10  
3.01 *Intent* .....10  
3.02 *Reference Standards*.....10  
3.03 *Reporting and Resolving Discrepancies*.....11  
3.04 *Amending and Supplementing Contract Documents*.....11  
3.05 *Reuse of Documents* .....11

ARTICLE 4 - AVAILABILITY OF LANDS; SUBSURFACE AND PHYSICAL CONDITIONS; REFERENCE POINTS .....11  
4.01 *Availability of Lands* .....11  
4.02 *Subsurface and Physical Conditions* .....12  
4.03 *Differing Subsurface or Physical Conditions* .....12  
4.04 *Underground Facilities* .....13  
4.05 *Reference Points*.....14  
4.06 *Hazardous Environmental Condition at Site*.....14

ARTICLE 5 - BONDS AND INSURANCE .....15  
5.01 *Performance, Payment, and Other Bonds* .....15  
5.02 *Licensed Sureties and Insurers* .....15  
5.03 *Certificates of Insurance* .....15  
5.04 *CONTRACTOR’s Liability Insurance* .....15  
5.05 *OWNER’s Liability Insurance* .....16  
5.06 *Property Insurance*.....16  
5.07 *Waiver of Rights* .....17  
5.08 *Receipt and Application of Insurance Proceeds*.....18  
5.09 *Acceptance of Bonds and Insurance; Option to Replace* .....18  
5.10 *Partial Utilization, Acknowledgment of Property Insurer* .....18

ARTICLE 6 - CONTRACTOR’S RESPONSIBILITIES .....18  
6.01 *Supervision and Superintendence* .....19  
6.02 *Labor; Working Hours*.....19  
6.03 *Services, Materials, and Equipment* .....19  
6.04 *Progress Schedule* .....19  
6.05 *Substitutes and “Or-Equals”* .....19  
6.07 *Patent Fees and Royalties* .....22  
6.08 *Permits*.....22  
6.09 *Laws and Regulations* .....22  
6.10 *Taxes*.....22

6.11 Use of Site and Other Areas.....	22
6.13 Safety and Protection .....	23
6.14 Safety Representative .....	23
6.15 Hazard Communication Programs.....	24
6.16 Emergencies .....	24
6.17 Shop Drawings and Samples .....	24
6.18 Continuing the Work .....	25
6.19 CONTRACTOR's General Warranty and Guarantee.....	25
6.20 Indemnification.....	25
ARTICLE 7 - OTHER WORK .....	26
7.01 Related Work at Site .....	26
7.02 Coordination .....	27
ARTICLE 8 - OWNER'S RESPONSIBILITIES.....	27
8.01 Communications to Contractor .....	27
8.02 Replacement of ENGINEER .....	27
8.03 Furnish Data .....	27
8.04 Pay Promptly When Due.....	27
8.05 Lands and Easements; Reports and Tests .....	27
8.06 Insurance .....	27
8.07 Change Orders .....	27
8.08 Inspections, Tests, and Approvals.....	27
8.09 Limitations on OWNER's Responsibilities .....	27
8.10 Undisclosed Hazardous Environmental Condition.....	27
8.11 Evidence of Financial Arrangements .....	27
ARTICLE 9 - ENGINEER'S STATUS DURING CONSTRUCTION .....	28
9.01 OWNER'S Representative .....	28
9.02 Visits to Site .....	28
9.03 Project Representative .....	28
9.04 Clarifications and Interpretations .....	28
9.05 Authorized Variations in Work .....	28
9.06 Rejecting Defective Work.....	28
9.07 Shop Drawings, Change Orders and Payments.....	28
9.08 Determinations for Unit Price Work.....	28
9.09 Decisions on Requirements of Contract Documents and Acceptability of Work .....	29
9.10 Limitations on ENGINEER's Authority and Responsibilities .....	29
ARTICLE 10 - CHANGES IN THE WORK; CLAIMS .....	29
10.01 Authorized Changes in the Work .....	29
10.02 Unauthorized Changes in the Work.....	30
10.03 Execution of Change Orders.....	30
10.04 Notification to Surety .....	30
10.05 Claims and Disputes .....	30
ARTICLE 11 - COST OF THE WORK; CASH ALLOWANCES; UNIT PRICE WORK.....	31
11.01 Cost of the Work.....	31
11.02 Cash Allowances .....	32
11.03 Unit Price Work .....	33
ARTICLE 12 - CHANGE OF CONTRACT PRICE; CHANGE OF CONTRACT TIMES .....	33
12.01 Change of Contract Price .....	33
12.02 Change of Contract Times .....	34
12.03 Delays Beyond CONTRACTOR's Control.....	34
12.04 Delays Within CONTRACTOR's Control .....	34
12.06 Delay Damages .....	34

ARTICLE 13 - TESTS AND INSPECTIONS; CORRECTION, REMOVAL OR ACCEPTANCE OF DEFECTIVE WORK.....	35
13.01 <i>Notice of Defects</i> .....	35
13.02 <i>Access to Work</i> .....	35
13.03 <i>Tests and Inspections</i> .....	35
13.04 <i>Uncovering Work</i> .....	35
13.05 <i>OWNER May Stop the Work</i> .....	36
13.06 <i>Correction or Removal of Defective Work</i> .....	36
13.07 <i>Correction Period</i> .....	36
13.08 <i>Acceptance of Defective Work</i> .....	36
13.09 <i>OWNER May Correct Defective Work</i> .....	36
 ARTICLE 14 - PAYMENTS TO CONTRACTOR AND COMPLETION.....	 37
14.01 <i>Schedule of Values</i> .....	37
14.02 <i>Progress Payments</i> .....	37
14.03 <i>CONTRACTOR's Warranty of Title</i> .....	39
14.04 <i>Substantial Completion</i> .....	39
14.05 <i>Partial Utilization</i> .....	39
14.06 <i>Final Inspection</i> .....	40
14.07 <i>Final Payment</i> .....	40
14.08 <i>Final Completion Delayed</i> .....	40
14.09 <i>Waiver of Claims</i> .....	41
 ARTICLE 15 - SUSPENSION OF WORK AND TERMINATION .....	 41
15.01 <i>OWNER May Suspend Work</i> .....	41
15.02 <i>OWNER May Terminate for Cause</i> .....	41
15.03 <i>OWNER May Terminate For Convenience</i> .....	42
15.04 <i>CONTRACTOR May Stop Work or Terminate</i> .....	42
 ARTICLE 16 - DISPUTE RESOLUTION.....	 42
16.01 <i>Methods and Procedures</i> .....	42
 ARTICLE 17 - MISCELLANEOUS .....	 42
17.01 <i>Giving Notice</i> .....	42
17.02 <i>Computation of Times</i> .....	42
17.03 <i>Cumulative Remedies</i> .....	43
17.04 <i>Survival of Obligations</i> .....	43
17.05 <i>Controlling Law</i> .....	43

## GENERAL CONDITIONS

### ARTICLE 1 - DEFINITIONS AND TERMINOLOGY

#### 1.01 *Defined Terms*

A. Wherever used in the Contract Documents and printed with initial or all capital letters, the terms listed below will have the meanings indicated which are applicable to both the singular and plural thereof.

1. *Addenda*--Written or graphic instruments issued prior to the opening of Bids which clarify, correct, or change the Bidding Requirements or the Contract Documents.

2. *Agreement*--The written instrument which is evidence of the agreement between OWNER and CONTRACTOR covering the Work.

3. *Application for Payment*--The form acceptable to ENGINEER which is to be used by CONTRACTOR during the course of the Work in requesting progress or final payments and which is to be accompanied by such supporting documentation as is required by the Contract Documents.

4. *Asbestos*--Any material that contains more than one percent asbestos and is friable or is releasing asbestos fibers into the air above current action levels established by the United States Occupational Safety and Health Administration.

5. *Bid*--The offer or proposal of a bidder submitted on the prescribed form setting forth the prices for the Work to be performed.

6. *Bidding Documents*--The Bidding Requirements and the proposed Contract Documents (including all Addenda issued prior to receipt of Bids).

7. *Bidding Requirements*--The Advertisement or Invitation to Bid, Instructions to Bidders, Bid security form, if any, and the Bid form with any supplements.

8. *Bonds*--Performance and payment bonds and other instruments of security.

9. *Change Order*--A document recommended by ENGINEER which is signed by CONTRACTOR and OWNER and authorizes an addition, deletion, or revision in the Work or an adjustment in the Contract Price or the Contract Times, issued on or after the Effective Date of the Agreement.

10. *Claim*--A demand or assertion by OWNER or CONTRACTOR seeking an adjustment of Contract Price or Contract Times, or both, or other relief with respect to

the terms of the Contract. A demand for money or services by a third party is not a Claim.

11. *Contract*--The entire and integrated written agreement between the OWNER and CONTRACTOR concerning the Work. The Contract supersedes prior negotiations, representations, or agreements, whether written or oral.

12. *Contract Documents*--The Contract Documents establish the rights and obligations of the parties and include the Agreement, Addenda (which pertain to the Contract Documents), CONTRACTOR's Bid (including documentation accompanying the Bid and any post Bid documentation submitted prior to the Notice of Award) when attached as an exhibit to the Agreement, the Notice to Proceed, the Bonds, these General Conditions, the Supplementary Conditions, the Specifications and the Drawings as the same are more specifically identified in the Agreement, together with all Written Amendments, Change Orders, Work Change Directives, Field Orders, and ENGINEER's written interpretations and clarifications issued on or after the Effective Date of the Agreement. Approved Shop Drawings and the reports and drawings of subsurface and physical conditions are not Contract Documents. Only printed or hard copies of the items listed in this paragraph are Contract Documents. Files in electronic media format of text, data, graphics, and the like that may be furnished by OWNER to CONTRACTOR are not Contract Documents.

13. *Contract Price*--The moneys payable by OWNER to CONTRACTOR for completion of the Work in accordance with the Contract Documents as stated in the Agreement (subject to the provisions of paragraph 11.03 in the case of Unit Price Work).

14. *Contract Times*--The number of days or the dates stated in the Agreement to: (i) achieve Substantial Completion; and (ii) complete the Work so that it is ready for final payment as evidenced by ENGINEER's written recommendation of final payment.

15. *CONTRACTOR*--The individual or entity with whom OWNER has entered into the Agreement.

16. *Cost of the Work*--See paragraph 11.01.A for definition.

17. *Drawings*--That part of the Contract Documents prepared or approved by ENGINEER which graphically shows the scope, extent, and character of the Work to be performed by CONTRACTOR. Shop Drawings and other CONTRACTOR submittals are not Drawings as so defined.

---

18. *Effective Date of the Agreement*--The date indicated in the Agreement on which it becomes effective, but if no such date is indicated, it means the date on which the Agreement is signed and delivered by the last of the two parties to sign and deliver.

19. *ENGINEER*--The individual or entity named as such in the Agreement.

20. *ENGINEER's Consultant*--An individual or entity having a contract with ENGINEER to furnish services as ENGINEER's independent professional associate or consultant with respect to the Project and who is identified as such in the Supplementary Conditions.

21. *Field Order*--A written order issued by ENGINEER which requires minor changes in the Work but which does not involve a change in the Contract Price or the Contract Times.

22. *General Requirements*--Sections of Division 1 of the Specifications. The General Requirements pertain to all sections of the Specifications.

23. *Hazardous Environmental Condition*--The presence at the Site of Asbestos, PCBs, Petroleum, Hazardous Waste, or Radioactive Material in such quantities or circumstances that may present a substantial danger to persons or property exposed thereto in connection with the Work.

24. *Hazardous Waste*--The term Hazardous Waste shall have the meaning provided in Section 1004 of the Solid Waste Disposal Act (42 USC Section 6903) as amended from time to time.

25. *Laws and Regulations; Laws or Regulations*--Any and all applicable laws, rules, regulations, ordinances, codes, and orders of any and all governmental bodies, agencies, authorities, and courts having jurisdiction.

26. *Liens*--Charges, security interests, or encumbrances upon Project funds, real property, or personal property.

27. *Milestone*--A principal event specified in the Contract Documents relating to an intermediate completion date or time prior to Substantial Completion of all the Work.

28. *Notice of Award*--The written notice by OWNER to the apparent successful bidder stating that upon timely compliance by the apparent successful bidder with the conditions precedent listed therein, OWNER will sign and deliver the Agreement.

29. *Notice to Proceed*--A written notice given by OWNER to CONTRACTOR fixing the date on which the

Contract Times will commence to run and on which CONTRACTOR shall start to perform the Work under the Contract Documents.

30. *OWNER*--The individual, entity, public body, or authority with whom CONTRACTOR has entered into the Agreement and for whom the Work is to be performed.

31. *Partial Utilization*--Use by OWNER of a substantially completed part of the Work for the purpose for which it is intended (or a related purpose) prior to Substantial Completion of all the Work.

32. *PCBs*--Polychlorinated biphenyls.

33. *Petroleum*--Petroleum, including crude oil or any fraction thereof which is liquid at standard conditions of temperature and pressure (60 degrees Fahrenheit and 14.7 pounds per square inch absolute), such as oil, petroleum, fuel oil, oil sludge, oil refuse, gasoline, kerosene, and oil mixed with other non-Hazardous Waste and crude oils.

34. *Project*--The total construction of which the Work to be performed under the Contract Documents may be the whole, or a part as may be indicated elsewhere in the Contract Documents.

35. *Project Manual*--The bound documentary information prepared for bidding and constructing the Work. A listing of the contents of the Project Manual, which may be bound in one or more volumes, is contained in the table(s) of contents.

36. *Radioactive Material*--Source, special nuclear, or byproduct material as defined by the Atomic Energy Act of 1954 (42 USC Section 2011 et seq.) as amended from time to time.

37. *Resident Project Representative*--The authorized representative of ENGINEER who may be assigned to the Site or any part thereof.

38. *Samples*--Physical examples of materials, equipment, or workmanship that are representative of some portion of the Work and which establish the standards by which such portion of the Work will be judged.

39. *Shop Drawings*--All drawings, diagrams, illustrations, schedules, and other data or information which are specifically prepared or assembled by or for CONTRACTOR and submitted by CONTRACTOR to illustrate some portion of the Work.

40. *Site*--Lands or areas indicated in the Contract Documents as being furnished by OWNER upon which the Work is to be performed, including rights-of-way and easements for access thereto, and such other lands

---

furnished by OWNER which are designated for the use of CONTRACTOR.

41. *Specifications*--That part of the Contract Documents consisting of written technical descriptions of materials, equipment, systems, standards, and workmanship as applied to the Work and certain administrative details applicable thereto.

42. *Subcontractor*--An individual or entity having a direct contract with CONTRACTOR or with any other Subcontractor for the performance of a part of the Work at the Site.

43. *Substantial Completion*--The time at which the Work (or a specified part thereof) has progressed to the point where, in the opinion of ENGINEER, the Work (or a specified part thereof) is sufficiently complete, in accordance with the Contract Documents, so that the Work (or a specified part thereof) can be utilized for the purposes for which it is intended. The terms "substantially complete" and "substantially completed" as applied to all or part of the Work refer to Substantial Completion thereof.

44. *Supplementary Conditions*--That part of the Contract Documents which amends or supplements these General Conditions.

45. *Supplier*--A manufacturer, fabricator, supplier, distributor, materialman, or vendor having a direct contract with CONTRACTOR or with any Subcontractor to furnish materials or equipment to be incorporated in the Work by CONTRACTOR or any Subcontractor.

46. *Underground Facilities*--All underground pipelines, conduits, ducts, cables, wires, manholes, vaults, tanks, tunnels, or other such facilities or attachments, and any encasements containing such facilities, including those that convey electricity, gases, steam, liquid petroleum products, telephone or other communications, cable television, water, wastewater, storm water, other liquids or chemicals, or traffic or other control systems.

47. *Unit Price Work*--Work to be paid for on the basis of unit prices.

48. *Work*--The entire completed construction or the various separately identifiable parts thereof required to be provided under the Contract Documents. Work includes and is the result of performing or providing all labor, services, and documentation necessary to produce such construction, and furnishing, installing, and incorporating all materials and equipment into such construction, all as required by the Contract Documents.

49. *Work Change Directive*--A written statement to CONTRACTOR issued on or after the Effective Date of the Agreement and signed by OWNER and recommended

by ENGINEER ordering an addition, deletion, or revision in the Work, or responding to differing or unforeseen subsurface or physical conditions under which the Work is to be performed or to emergencies. A Work Change Directive will not change the Contract Price or the Contract Times but is evidence that the parties expect that the change ordered or documented by a Work Change Directive will be incorporated in a subsequently issued Change Order following negotiations by the parties as to its effect, if any, on the Contract Price or Contract Times.

50. *Written Amendment*--A written statement modifying the Contract Documents, signed by OWNER and CONTRACTOR on or after the Effective Date of the Agreement and normally dealing with the nonengineering or nontechnical rather than strictly construction-related aspects of the Contract Documents.

## 1.02 Terminology

### A. Intent of Certain Terms or Adjectives

1. Whenever in the Contract Documents the terms "as allowed," "as approved," or terms of like effect or import are used, or the adjectives "reasonable," "suitable," "acceptable," "proper," "satisfactory," or adjectives of like effect or import are used to describe an action or determination of ENGINEER as to the Work, it is intended that such action or determination will be solely to evaluate, in general, the completed Work for compliance with the requirements of and information in the Contract Documents and conformance with the design concept of the completed Project as a functioning whole as shown or indicated in the Contract Documents (unless there is a specific statement indicating otherwise). The use of any such term or adjective shall not be effective to assign to ENGINEER any duty or authority to supervise or direct the performance of the Work or any duty or authority to undertake responsibility contrary to the provisions of paragraph 9.10 or any other provision of the Contract Documents.

### B. Day

1. The word "day" shall constitute a calendar day of 24 hours measured from midnight to the next midnight.

### C. Defective

1. The word "defective," when modifying the word "Work," refers to Work that is unsatisfactory, faulty, or deficient in that it does not conform to the Contract Documents or does not meet the requirements of any inspection, reference standard, test, or approval referred to in the Contract Documents, or has been damaged prior to

---

ENGINEER's recommendation of final payment (unless responsibility for the protection thereof has been assumed by OWNER at Substantial Completion in accordance with paragraph 14.04 or 14.05).

D. *Furnish, Install, Perform, Provide*

1. The word "furnish," when used in connection with services, materials, or equipment, shall mean to supply and deliver said services, materials, or equipment to the Site (or some other specified location) ready for use or installation and in usable or operable condition.

2. The word "install," when used in connection with services, materials, or equipment, shall mean to put into use or place in final position said services, materials, or equipment complete and ready for intended use.

3. The words "perform" or "provide," when used in connection with services, materials, or equipment, shall mean to furnish and install said services, materials, or equipment complete and ready for intended use.

4. When "furnish," "install," "perform," or "provide" is not used in connection with services, materials, or equipment in a context clearly requiring an obligation of CONTRACTOR, "provide" is implied.

E. Unless stated otherwise in the Contract Documents, words or phrases which have a well-known technical or construction industry or trade meaning are used in the Contract Documents in accordance with such recognized meaning.

---

ARTICLE 2 - PRELIMINARY MATTERS

---

2.01 *Delivery of Bonds*

A. When CONTRACTOR delivers the executed Agreements to OWNER, CONTRACTOR shall also deliver to OWNER such Bonds as CONTRACTOR may be required to furnish.

2.02 *Copies of Documents*

SEE SUPPLEMENTARY CONDITIONS (SECTION 00800)

~~A. OWNER shall furnish to CONTRACTOR up to ten copies of the Contract Documents. Additional copies will be furnished upon request at the cost of reproduction.~~

2.03 *Commencement of Contract Times; Notice to Proceed*

A. The Contract Times will commence to run on the thirtieth day after the Effective Date of the Agreement or, if a Notice to Proceed is given, on the day indicated in the Notice to Proceed. A Notice to Proceed may be given at any time within 30 days after the Effective Date of the Agreement. In no event will the Contract Times commence to run later than the sixtieth day after the day of Bid opening or the thirtieth day after the Effective Date of the Agreement, whichever date is earlier.

2.04 *Starting the Work*

SEE SUPPLEMENTARY CONDITIONS (SECTION 00800)

~~A. CONTRACTOR shall start to perform the Work on the date when the Contract Times commence to run. No Work shall be done at the Site prior to the date on which the Contract Times commence to run.~~

2.05 *Before Starting Construction*

A. *CONTRACTOR's Review of Contract Documents:* Before undertaking each part of the Work, CONTRACTOR shall carefully study and compare the Contract Documents and check and verify pertinent figures therein and all applicable field measurements. CONTRACTOR shall promptly report in writing to ENGINEER any conflict, error, ambiguity, or discrepancy which CONTRACTOR may discover and shall obtain a written interpretation or clarification from ENGINEER before proceeding with any Work affected thereby; however, CONTRACTOR shall not be liable to OWNER or ENGINEER for failure to report any conflict, error, ambiguity, or discrepancy in the Contract Documents unless CONTRACTOR knew or reasonably should have known thereof.

B. *Preliminary Schedules:* Within ten days after the Effective Date of the Agreement (unless otherwise specified in the General Requirements), CONTRACTOR shall submit to ENGINEER for its timely review:

1. a preliminary progress schedule indicating the times (numbers of days or dates) for starting and completing the various stages of the Work, including any Milestones specified in the Contract Documents;

2. a preliminary schedule of Shop Drawing and Sample submittals which will list each required submittal and the times for submitting, reviewing, and processing such submittal; and



3. a preliminary schedule of values for all of the Work which includes quantities and prices of items which when added together equal the Contract Price and subdivides the Work into component parts in sufficient detail to serve as the basis for progress payments during performance of the Work. Such prices will include an appropriate amount of overhead and profit applicable to each item of Work.

SEE SUPPLEMENTARY CONDITIONS (SECTION 00800)

~~C. Evidence of Insurance: Before any Work at the Site is started, CONTRACTOR and OWNER shall each deliver to the other, with copies to each additional insured identified in the Supplementary Conditions, certificates of insurance (and other evidence of insurance which either of them or any additional insured may reasonably request) which CONTRACTOR and OWNER respectively are required to purchase and maintain in accordance with Article 5.~~

#### 2.06 Preconstruction Conference

SEE SUPPLEMENTARY CONDITIONS (SECTION 00800)

~~A. Within 20 days after the Contract Times start to run, but before any Work at the Site is started, a conference attended by CONTRACTOR, ENGINEER, and others as appropriate will be held to establish a working understanding among the parties as to the Work and to discuss the schedules referred to in paragraph 2.05.B, procedures for handling Shop Drawings and other submittals, processing Applications for Payment, and maintaining required records.~~

#### 2.07 Initial Acceptance of Schedules

SEE SUPPLEMENTARY CONDITIONS (SECTION 00800)

~~A. Unless otherwise provided in the Contract Documents, at least ten days before submission of the first Application for Payment a conference attended by CONTRACTOR, ENGINEER, and others as appropriate will be held to review for acceptability to ENGINEER as provided below the schedules submitted in accordance with paragraph 2.05.B. CONTRACTOR shall have an additional ten days to make corrections and adjustments and to complete and resubmit the schedules. No progress payment shall be made to CONTRACTOR until acceptable schedules are submitted to ENGINEER.~~

~~1. The progress schedule will be acceptable to ENGINEER if it provides an orderly progression of the Work to completion within any specified Milestones and the Contract Times. Such acceptance will not impose on ENGINEER~~

~~responsibility for the progress schedule, for sequencing, scheduling, or progress of the Work nor interfere with or relieve CONTRACTOR from CONTRACTOR's full responsibility therefore.~~

~~2. CONTRACTOR's schedule of Shop Drawing and Sample submittals will be acceptable to ENGINEER if it provides a workable arrangement for reviewing and processing the required submittals.~~

~~3. CONTRACTOR's schedule of values will be acceptable to ENGINEER as to form and substance if it provides a reasonable allocation of the Contract Price to component parts of the Work.~~

### ARTICLE 3 - CONTRACT DOCUMENTS: INTENT, AMENDING, REUSE

#### 3.01 Intent

SEE ALSO SUPPLEMENTARY CONDITIONS (SECTION 00800)

A. The Contract Documents are complementary; what is called for by one is as binding as if called for by all.

B. It is the intent of the Contract Documents to describe a functionally complete Project (or part thereof) to be constructed in accordance with the Contract Documents. Any labor, documentation, services, materials, or equipment that may reasonably be inferred from the Contract Documents or from prevailing custom or trade usage as being required to produce the intended result will be provided whether or not specifically called for at no additional cost to OWNER.

C. Clarifications and interpretations of the Contract Documents shall be issued by ENGINEER as provided in Article 9.

#### 3.02 Reference Standards

A. *Standards, Specifications, Codes, Laws, and Regulations*

1. Reference to standards, specifications, manuals, or codes of any technical society, organization, or association, or to Laws or Regulations, whether such reference be specific or by implication, shall mean the standard, specification, manual, code, or Laws or Regulations in effect at the time of opening of Bids (or on the Effective Date of the Agreement if there were no Bids), except as may be otherwise specifically stated in the Contract Documents.

---

2. No provision of any such standard, specification, manual or code, or any instruction of a Supplier shall be effective to change the duties or responsibilities of OWNER, CONTRACTOR, or ENGINEER, or any of their subcontractors, consultants, agents, or employees from those set forth in the Contract Documents, nor shall any such provision or instruction be effective to assign to OWNER, ENGINEER, or any of ENGINEER's Consultants, agents, or employees any duty or authority to supervise or direct the performance of the Work or any duty or authority to undertake responsibility inconsistent with the provisions of the Contract Documents.

### 3.03 *Reporting and Resolving Discrepancies*

#### A. *Reporting Discrepancies*

1. If, during the performance of the Work, CONTRACTOR discovers any conflict, error, ambiguity, or discrepancy within the Contract Documents or between the Contract Documents and any provision of any Law or Regulation applicable to the performance of the Work or of any standard, specification, manual or code, or of any instruction of any Supplier, CONTRACTOR shall report it to ENGINEER in writing at once. CONTRACTOR shall not proceed with the Work affected thereby (except in an emergency as required by paragraph 6.16.A) until an amendment or supplement to the Contract Documents has been issued by one of the methods indicated in paragraph 3.04; provided, however, that CONTRACTOR shall not be liable to OWNER or ENGINEER for failure to report any such conflict, error, ambiguity, or discrepancy unless CONTRACTOR knew or reasonably should have known thereof.

#### B. *Resolving Discrepancies*

1. Except as may be otherwise specifically stated in the Contract Documents, the provisions of the Contract Documents shall take precedence in resolving any conflict, error, ambiguity, or discrepancy between the provisions of the Contract Documents and:

a. the provisions of any standard, specification, manual, code, or instruction (whether or not specifically incorporated by reference in the Contract Documents); or

b. the provisions of any Laws or Regulations applicable to the performance of the Work (unless such an interpretation of the provisions of the Contract Documents would result in violation of such Law or Regulation).

### 3.04 *Amending and Supplementing Contract Documents*

A. The Contract Documents may be amended to provide for additions, deletions, and revisions in the Work or to modify the terms and conditions thereof in one or more of the following ways: (i) a Written Amendment; (ii) a Change Order; or (iii) a Work Change Directive.

B. The requirements of the Contract Documents may be supplemented, and minor variations and deviations in the Work may be authorized, by one or more of the following ways: (i) a Field Order; (ii) ENGINEER's approval of a Shop Drawing or Sample; or (iii) ENGINEER's written interpretation or clarification.

### 3.05 *Reuse of Documents*

A. CONTRACTOR and any Subcontractor or Supplier or other individual or entity performing or furnishing any of the Work under a direct or indirect contract with OWNER: (i) shall not have or acquire any title to or ownership rights in any of the Drawings, Specifications, or other documents (or copies of any thereof) prepared by or bearing the seal of ENGINEER or ENGINEER's Consultant, including electronic media editions; and (ii) shall not reuse any of such Drawings, Specifications, other documents, or copies thereof on extensions of the Project or any other project without written consent of OWNER and ENGINEER and specific written verification or adaption by ENGINEER. This prohibition will survive final payment, completion, and acceptance of the Work, or termination or completion of the Contract. Nothing herein shall preclude CONTRACTOR from retaining copies of the Contract Documents for record purposes.

## ARTICLE 4 - AVAILABILITY OF LANDS; SUBSURFACE AND PHYSICAL CONDITIONS; REFERENCE POINTS

### 4.01 *Availability of Lands*

A. OWNER shall furnish the Site. OWNER shall notify CONTRACTOR of any encumbrances or restrictions not of general application but specifically related to use of the Site with which CONTRACTOR must comply in performing the Work. OWNER will obtain in a timely manner and pay for easements for permanent structures or permanent changes in existing facilities. If CONTRACTOR and OWNER are unable to agree on entitlement to or on the amount or extent, if any, of any adjustment in the Contract Price or Contract Times, or both, as a result of any delay in OWNER's furnishing the Site, CONTRACTOR may make a Claim therefor as provided in paragraph 10.05.

B. Upon reasonable written request, OWNER shall furnish CONTRACTOR with a current statement of record legal title and legal description of the lands upon which the Work is to be performed and OWNER's interest therein as necessary for giving notice of or filing a mechanic's or construction lien against such lands in accordance with applicable Laws and Regulations.

C. CONTRACTOR shall provide for all additional lands and access thereto that may be required for temporary construction facilities or storage of materials and equipment.

#### 4.02 *Subsurface and Physical Conditions*

A. *Reports and Drawings:* The Supplementary Conditions identify:

1. those reports of explorations and tests of subsurface conditions at or contiguous to the Site that ENGINEER has used in preparing the Contract Documents; and

2. those drawings of physical conditions in or relating to existing surface or subsurface structures at or contiguous to the Site (except Underground Facilities) that ENGINEER has used in preparing the Contract Documents.

B. *Limited Reliance by CONTRACTOR on Technical Data Authorized:* CONTRACTOR may rely upon the general accuracy of the "technical data" contained in such reports and drawings, but such reports and drawings are not Contract Documents. Such "technical data" is identified in the Supplementary Conditions. Except for such reliance on such "technical data," CONTRACTOR may not rely upon or make any Claim against OWNER, ENGINEER, or any of ENGINEER's Consultants with respect to:

1. the completeness of such reports and drawings for CONTRACTOR's purposes, including, but not limited to, any aspects of the means, methods, techniques, sequences, and procedures of construction to be employed by CONTRACTOR, and safety precautions and programs incident thereto; or

2. other data, interpretations, opinions, and information contained in such reports or shown or indicated in such drawings; or

3. any CONTRACTOR interpretation of or conclusion drawn from any "technical data" or any such other data, interpretations, opinions, or information.

#### 4.03 *Differing Subsurface or Physical Conditions*

SEE ALSO SUPPLEMENTARY CONDITIONS (SECTION 00800)

A. *Notice:* If CONTRACTOR believes that any subsurface or physical condition at or contiguous to the Site that is uncovered or revealed either:

1. is of such a nature as to establish that any "technical data" on which CONTRACTOR is entitled to rely as provided in paragraph 4.02 is materially inaccurate; or

2. is of such a nature as to require a change in the Contract Documents; or

3. differs materially from that shown or indicated in the Contract Documents; or

4. is of an unusual nature, and differs materially from conditions ordinarily encountered and generally recognized as inherent in work of the character provided for in the Contract Documents;

then CONTRACTOR shall, promptly after becoming aware thereof and before further disturbing the subsurface or physical conditions or performing any Work in connection therewith (except in an emergency as required by paragraph 6.16.A), notify OWNER and ENGINEER in writing about such condition. CONTRACTOR shall not further disturb such condition or perform any Work in connection therewith (except as aforesaid) until receipt of written order to do so.

B. *ENGINEER's Review:* After receipt of written notice as required by paragraph 4.03.A, ENGINEER will promptly review the pertinent condition, determine the necessity of OWNER's obtaining additional exploration or tests with respect thereto, and advise OWNER in writing (with a copy to CONTRACTOR) of ENGINEER's findings and conclusions.

#### C. *Possible Price and Times Adjustments*

1. The Contract Price or the Contract Times, or both, will be equitably adjusted to the extent that the existence of such differing subsurface or physical condition causes an increase or decrease in CONTRACTOR's cost of, or time required for, performance of the Work; subject, however, to the following:

a. such condition must meet any one or more of the categories described in paragraph 4.03.A; and

---

b. with respect to Work that is paid for on a Unit Price Basis, any adjustment in Contract Price will be subject to the provisions of paragraphs 9.08 and 11.03.

2. CONTRACTOR shall not be entitled to any adjustment in the Contract Price or Contract Times if:

a. CONTRACTOR knew of the existence of such conditions at the time CONTRACTOR made a final commitment to OWNER in respect of Contract Price and Contract Times by the submission of a Bid or becoming bound under a negotiated contract; or

b. the existence of such condition could reasonably have been discovered or revealed as a result of any examination, investigation, exploration, test, or study of the Site and contiguous areas required by the Bidding Requirements or Contract Documents to be conducted by or for CONTRACTOR prior to CONTRACTOR's making such final commitment; or

c. CONTRACTOR failed to give the written notice within the time and as required by paragraph 4.03.A.

3. If OWNER and CONTRACTOR are unable to agree on entitlement to or on the amount or extent, if any, of any adjustment in the Contract Price or Contract Times, or both, a Claim may be made therefore as provided in paragraph 10.05. However, OWNER, ENGINEER, and ENGINEER's Consultants shall not be liable to CONTRACTOR for any claims, costs, losses, or damages (including but not limited to all fees and charges of engineers, architects, attorneys, and other professionals and all court or arbitration or other dispute resolution costs) sustained by CONTRACTOR on or in connection with any other project or anticipated project.

#### 4.04 *Underground Facilities*

*SEE ALSO SUPPLEMENTARY CONDITIONS (SECTION 00800)*

A. *Shown or Indicated:* The information and data shown or indicated in the Contract Documents with respect to existing Underground Facilities at or contiguous to the Site is based on information and data furnished to OWNER or ENGINEER by the owners of such Underground Facilities, including OWNER, or by others. Unless it is otherwise expressly provided in the Supplementary Conditions:

1. OWNER and ENGINEER shall not be responsible for the accuracy or completeness of any such information or data; and

2. the cost of all of the following will be included in the Contract Price, and CONTRACTOR shall have full responsibility for:

a. reviewing and checking all such information and data,

b. locating all Underground Facilities shown or indicated in the Contract Documents,

c. coordination of the Work with the owners of such Underground Facilities, including OWNER, during construction, and

d. the safety and protection of all such Underground Facilities and repairing any damage thereto resulting from the Work.

#### B. *Not Shown or Indicated*

1. If an Underground Facility is uncovered or revealed at or contiguous to the Site which was not shown or indicated, or not shown or indicated with reasonable accuracy in the Contract Documents, CONTRACTOR shall, promptly after becoming aware thereof and before further disturbing conditions affected thereby or performing any Work in connection therewith (except in an emergency as required by paragraph 6.16.A), identify the owner of such Underground Facility and give written notice to that owner and to OWNER and ENGINEER. ENGINEER will promptly review the Underground Facility and determine the extent, if any, to which a change is required in the Contract Documents to reflect and document the consequences of the existence or location of the Underground Facility. During such time, CONTRACTOR shall be responsible for the safety and protection of such Underground Facility.

2. If ENGINEER concludes that a change in the Contract Documents is required, a Work Change Directive or a Change Order will be issued to reflect and document such consequences. An equitable adjustment shall be made in the Contract Price of Contract Times, or both, to the extent that they are attributable to the existence or location of any Underground Facility that was not shown or indicated or not shown or indicated with reasonable accuracy in the Contract Documents and that CONTRACTOR did not know of and could not reasonably have been expected to be aware of or to

---

have anticipated. If OWNER and CONTRACTOR are unable to agree on entitlement to or on the amount or extent, if any, of any such adjustment in Contract Price or Contract Times, OWNER or CONTRACTOR may make a Claim therefor as provided in paragraph 10.05.

#### 4.05 *Reference Points*

A. OWNER shall provide engineering surveys to establish reference points for construction which in ENGINEER's judgment are necessary to enable CONTRACTOR to proceed with the Work. CONTRACTOR shall be responsible for laying out the Work, shall protect and preserve the established reference points and property monuments, and shall make no changes or relocations without the prior written approval of OWNER. CONTRACTOR shall report to ENGINEER whenever any reference point or property monument is lost or destroyed or requires relocation because of necessary changes in grades or locations, and shall be responsible for the accurate replacement or relocation of such reference points or property monuments by professionally qualified personnel.

#### 4.06 *Hazardous Environmental Condition at Site*

A. *Reports and Drawings:* Reference is made to the Supplementary Conditions for the identification of those reports and drawings relating to a Hazardous Environmental Condition identified at the Site, if any, that have been utilized by the ENGINEER in the preparation of the Contract Documents.

B. *Limited Reliance by CONTRACTOR on Technical Data Authorized:* CONTRACTOR may rely upon the general accuracy of the "technical data" contained in such reports and drawings, but such reports and drawings are not Contract Documents. Such "technical data" is identified in the Supplementary Conditions. Except for such reliance on such "technical data," CONTRACTOR may not rely upon or make any Claim against OWNER, ENGINEER or any of ENGINEER's Consultants with respect to:

1. the completeness of such reports and drawings for CONTRACTOR's purposes, including, but not limited to, any aspects of the means, methods, techniques, sequences and procedures of construction to be employed by CONTRACTOR and safety precautions and programs incident thereto; or
2. other data, interpretations, opinions and information contained in such reports or shown or indicated in such drawings; or
3. any CONTRACTOR interpretation of or conclusion drawn from any "technical data" or any

such other data, interpretations, opinions or information.

C. CONTRACTOR shall not be responsible for any Hazardous Environmental Condition uncovered or revealed at the Site which was not shown or indicated in Drawings or Specifications or identified in the Contract Documents to be within the scope of the Work. CONTRACTOR shall be responsible for a Hazardous Environmental Condition created with any materials brought to the Site by CONTRACTOR, Subcontractors, Suppliers, or anyone else for whom CONTRACTOR is responsible.

D. If CONTRACTOR encounters a Hazardous Environmental Condition or if CONTRACTOR or anyone for whom CONTRACTOR is responsible creates a Hazardous Environmental Condition, CONTRACTOR shall immediately: (i) secure or otherwise isolate such condition; (ii) stop all Work in connection with such condition and in any area affected thereby (except in an emergency as required by paragraph 6.16); and (iii) notify OWNER and ENGINEER (and promptly thereafter confirm such notice in writing). OWNER shall promptly consult with ENGINEER concerning the necessity for OWNER to retain a qualified expert to evaluate such condition or take corrective action, if any.

E. CONTRACTOR shall not be required to resume Work in connection with such condition or in any affected area until after OWNER has obtained any required permits related thereto and delivered to CONTRACTOR written notice: (i) specifying that such condition and any affected area is or has been rendered safe for the resumption of Work; or (ii) specifying any special conditions under which such Work may be resumed safely. If OWNER and CONTRACTOR cannot agree as to entitlement to or on the amount or extent, if any, of any adjustment in Contract Price or Contract Times, or both, as a result of such Work stoppage or such special conditions under which Work is agreed to be resumed by CONTRACTOR, either party may make a Claim therefor as provided in paragraph 10.05.

F. If after receipt of such written notice CONTRACTOR does not agree to resume such Work based on a reasonable belief it is unsafe, or does not agree to resume such Work under such special conditions, then OWNER may order the portion of the Work that is in the area affected by such condition to be deleted from the Work. If OWNER and CONTRACTOR cannot agree as to entitlement to or on the amount or extent, if any, of an adjustment in Contract Price or Contract Times as a result of deleting such portion of the Work, then either party may make a Claim therefor as provided in paragraph 10.05. OWNER may have such deleted portion of the Work performed by OWNER's own forces or others in accordance with Article 7.

G. To the fullest extent permitted by Laws and Regulations, OWNER shall indemnify and hold harmless

CONTRACTOR, Subcontractors, ENGINEER, ENGINEER's Consultants and the officers, directors, partners, employees, agents, other consultants, and subcontractors of each and any of them from and against all claims, costs, losses, and damages (including but not limited to all fees and charges of engineers, architects, attorneys, and other professionals and all court or arbitration or other dispute resolution costs) arising out of or relating to a Hazardous Environmental Condition, provided that such Hazardous Environmental Condition: (i) was not shown or indicated in the Drawings or Specifications or identified in the Contract Documents to be included within the scope of the Work, and (ii) was not created by CONTRACTOR or by anyone for whom CONTRACTOR is responsible. Nothing in this paragraph 4.06.E shall obligate OWNER to indemnify any individual or entity from and against the consequences of that individual's or entity's own negligence.

H. To the fullest extent permitted by Laws and Regulations, CONTRACTOR shall indemnify and hold harmless OWNER, ENGINEER, ENGINEER's Consultants, and the officers, directors, partners, employees, agents, other consultants, and subcontractors of each and any of them from and against all claims, costs, losses, and damages (including but not limited to all fees and charges of engineers, architects, attorneys, and other professionals and all court or arbitration or other dispute resolution costs) arising out of or relating to a Hazardous Environmental Condition created by CONTRACTOR or by anyone for whom CONTRACTOR is responsible. Nothing in this paragraph 4.06.F shall obligate CONTRACTOR to indemnify any individual or entity from and against the consequences of that individual's or entity's own negligence.

I. The provisions of paragraphs 4.02, 4.03, and 4.04 are not intended to apply to a Hazardous Environmental Condition uncovered or revealed at the Site.

## ARTICLE 5 - BONDS AND INSURANCE

### 5.01 *Performance, Payment, and Other Bonds*

A. CONTRACTOR shall furnish performance and payment Bonds, each in an amount at least equal to the Contract Price as security for the faithful performance and payment of all CONTRACTOR's obligations under the Contract Documents. These Bonds shall remain in effect at least until one year after the date when final payment becomes due, except as provided otherwise by Laws or Regulations or by the Contract Documents. CONTRACTOR shall also furnish such other Bonds as are required by the Contract Documents.

B. All Bonds shall be in the form prescribed by the Contract Documents except as provided otherwise by Laws

or Regulations, and shall be executed by such sureties as are named in the current list of "Companies Holding Certificates of Authority as Acceptable Sureties on Federal Bonds and as Acceptable Reinsuring Companies" as published in Circular 570 (amended) by the Financial Management Service, Surety Bond Branch, U.S. Department of the Treasury. All Bonds signed by an agent must be accompanied by a certified copy of such agent's authority to act.

C. If the surety on any Bond furnished by CONTRACTOR is declared bankrupt or becomes insolvent or its right to do business is terminated in any state where any part of the Project is located or it ceases to meet the requirements of paragraph 5.01.B, CONTRACTOR shall within 20 days thereafter substitute another Bond and surety, both of which shall comply with the requirements of paragraphs 5.01.B and 5.02.

### 5.02 *Licensed Sureties and Insurers*

A. All Bonds and insurance required by the Contract Documents to be purchased and maintained by OWNER or CONTRACTOR shall be obtained from surety or insurance companies that are duly licensed or authorized in the jurisdiction in which the Project is located to issue Bonds or insurance policies for the limits and coverages so required. Such surety and insurance companies shall also meet such additional requirements and qualifications as may be provided in the Supplementary Conditions.

### 5.03 *Certificates of Insurance*

A. CONTRACTOR shall deliver to OWNER, with copies to each additional insured identified in the Supplementary Conditions, certificates of insurance (and other evidence of insurance requested by OWNER or any other additional insured) which CONTRACTOR is required to purchase and maintain. OWNER shall deliver to CONTRACTOR, with copies to each additional insured identified in the Supplementary Conditions, certificates of insurance (and other evidence of insurance requested by CONTRACTOR or any other additional insured) which OWNER is required to purchase and maintain.

### 5.04 *CONTRACTOR's Liability Insurance*

*SEE ALSO SUPPLEMENTARY CONDITIONS (SECTION 00800)*

A. CONTRACTOR shall purchase and maintain such liability and other insurance as is appropriate for the Work being performed and as will provide protection from claims set forth below which may arise out of or result from CONTRACTOR's performance of the Work and CONTRACTOR's other obligations under the Contract Documents, whether it is to be performed by CONTRACTOR, any Subcontractor or Supplier, or by

anyone directly or indirectly employed by any of them to perform any of the Work, or by anyone for whose acts any of them may be liable:

1. claims under workers' compensation, disability benefits, and other similar employee benefit acts;
2. claims for damages because of bodily injury, occupational sickness or disease, or death of CONTRACTOR's employees;
3. claims for damages because of bodily injury, sickness or disease, or death of any person other than CONTRACTOR's employees;
4. claims for damages insured by reasonably available personal injury liability coverage which are sustained: (i) by any person as a result of an offense directly or indirectly related to the employment of such person by CONTRACTOR, or (ii) by any other person for any other reason;
5. claims for damages, other than to the Work itself, because of injury to or destruction of tangible property wherever located, including loss of use resulting there from; and
6. claims for damages because of bodily injury or death of any person or property damage arising out of the ownership, maintenance or use of any motor vehicle.

B. The policies of insurance so required by this paragraph 5.04 to be purchased and maintained shall:

1. with respect to insurance required by paragraphs 5.04.A.3 through 5.04.A.6 inclusive, include as additional insureds (subject to any customary exclusion in respect of professional liability) OWNER, ENGINEER, ENGINEER's Consultants, and any other individuals or entities identified in the Supplementary Conditions, all of whom shall be listed as additional insureds, and include coverage for the respective officers, directors, partners, employees, agents, and other consultants and subcontractors of each and any of all such additional insureds, and the insurance afforded to these additional insureds shall provide primary coverage for all claims covered thereby;
2. include at least the specific coverages and be written for not less than the limits of liability provided in the Supplementary Conditions or required by Laws or Regulations, whichever is greater;

3. include completed operations insurance;
4. include contractual liability insurance covering CONTRACTOR's indemnity obligations under paragraphs 6.07, 6.11, and 6.20;
5. contain a provision or endorsement that the coverage afforded will not be canceled, materially changed or renewal refused until at least thirty days prior written notice has been given to OWNER and CONTRACTOR and to each other additional insured identified in the Supplementary Conditions to whom a certificate of insurance has been issued (and the certificates of insurance furnished by the CONTRACTOR pursuant to paragraph 5.03 will so provide);
6. remain in effect at least until final payment and at all times thereafter when CONTRACTOR may be correcting, removing, or replacing defective Work in accordance with paragraph 13.07; and
7. with respect to completed operations insurance, and any insurance coverage written on a claims-made basis, remain in effect for at least two years after final payment (and CONTRACTOR shall furnish OWNER and each other additional insured identified in the Supplementary Conditions, to whom a certificate of insurance has been issued, evidence satisfactory to OWNER and any such additional insured of continuation of such insurance at final payment and one year thereafter).

#### 5.05 OWNER's Liability Insurance

A. In addition to the insurance required to be provided by CONTRACTOR under paragraph 5.04, OWNER, at OWNER's option, may purchase and maintain at OWNER's expense OWNER's own liability insurance as will protect OWNER against claims which may arise from operations under the Contract Documents.

#### 5.06 Property Insurance

SEE SUPPLEMENTARY CONDITIONS (SECTION 00800)

~~A. Unless otherwise provided in the Supplementary Conditions, OWNER shall purchase and maintain property insurance upon the Work at the Site in the amount of the full replacement cost thereof (subject to such deductible amounts as may be provided in the Supplementary Conditions or required by Laws and Regulations). This insurance shall:~~

- ~~1. include the interests of OWNER, CONTRACTOR, Subcontractors, ENGINEER,~~

~~ENGINEER's Consultants, and any other individuals or entities identified in the Supplementary Conditions, and the officers, directors, partners, employees, agents, and other consultants and subcontractors of each and any of them, each of whom is deemed to have an insurable interest and shall be listed as an additional insured;~~

~~2. be written on a Builder's Risk "all-risk" or open peril or special causes of loss policy form that shall at least include insurance for physical loss or damage to the Work, temporary buildings, false work, and materials and equipment in transit, and shall insure against at least the following perils or causes of loss: fire, lightning, extended coverage, theft, vandalism and malicious mischief, earthquake, collapse, debris removal, demolition occasioned by enforcement of Laws and Regulations, water damage, and such other perils or causes of loss as may be specifically required by the Supplementary Conditions;~~

~~3. include expenses incurred in the repair or replacement of any insured property (including but not limited to fees and charges of engineers and architects);~~

~~4. cover materials and equipment stored at the Site or at another location that was agreed to in writing by OWNER prior to being incorporated in the Work, provided that such materials and equipment have been included in an Application for Payment recommended by ENGINEER;~~

~~5. allow for partial utilization of the Work by OWNER;~~

~~6. include testing and startup; and~~

~~7. be maintained in effect until final payment is made unless otherwise agreed to in writing by OWNER, CONTRACTOR, and ENGINEER with 30 days written notice to each other additional insured to whom a certificate of insurance has been issued;~~

~~B. OWNER shall purchase and maintain such boiler and machinery insurance or additional property insurance as may be required by the Supplementary Conditions or Laws and Regulations which will include the interests of OWNER, CONTRACTOR, Subcontractors, ENGINEER, ENGINEER's Consultants, and any other individuals or entities identified in the Supplementary Conditions, each of whom is deemed to have an insurable interest and shall be listed as an insured or additional insured;~~

~~C. All the policies of insurance (and the certificates or other evidence thereof) required to be purchased and~~

~~maintained in accordance with paragraph 5.06 will contain a provision or endorsement that the coverage afforded will not be canceled or materially changed or renewal refused until at least 30 days prior written notice has been given to OWNER and CONTRACTOR and to each other additional insured to whom a certificate of insurance has been issued and will contain waiver provisions in accordance with paragraph 5.07;~~

~~D. OWNER shall not be responsible for purchasing and maintaining any property insurance specified in this paragraph 5.06 to protect the interests of CONTRACTOR, Subcontractors, or others in the Work to the extent of any deductible amounts that are identified in the Supplementary Conditions. The risk of loss within such identified deductible amount will be borne by CONTRACTOR, Subcontractors, or others suffering any such loss, and if any of them wishes property insurance coverage within the limits of such amounts, each may purchase and maintain it at the purchaser's own expense;~~

~~E. If CONTRACTOR requests in writing that other special insurance be included in the property insurance policies provided under paragraph 5.06, OWNER shall, if possible, include such insurance, and the cost thereof will be charged to CONTRACTOR by appropriate Change Order or Written Amendment. Prior to commencement of the Work at the Site, OWNER shall in writing advise CONTRACTOR whether or not such other insurance has been procured by OWNER;~~

## 5.07 Waiver of Rights

### SEE SUPPLEMENTARY CONDITIONS (SECTION 00800)

~~A. OWNER and CONTRACTOR intend that all policies purchased in accordance with paragraph 5.06 will protect OWNER, CONTRACTOR, Subcontractors, ENGINEER, ENGINEER's Consultants, and all other individuals or entities identified in the Supplementary Conditions to be listed as insureds or additional insureds (and the officers, directors, partners, employees, agents, and other consultants and subcontractors of each and any of them) in such policies and will provide primary coverage for all losses and damages caused by the perils or causes of loss covered thereby. All such policies shall contain provisions to the effect that in the event of payment of any loss or damage the insurers will have no rights of recovery against any of the insureds or additional insureds thereunder. OWNER and CONTRACTOR waive all rights against each other and their respective officers, directors, partners, employees, agents, and other consultants and subcontractors of each and any of them for all losses and damages caused by, arising out of or resulting from any of the perils or causes of loss covered by such policies and any other property insurance applicable to the Work; and, in addition, waive all such rights against Subcontractors;~~



---

~~ENGINEER, ENGINEER's Consultants, and all other individuals or entities identified in the Supplementary Conditions to be listed as insureds or additional insureds (and the officers, directors, partners, employees, agents, and other consultants and subcontractors of each and any of them) under such policies for losses and damages so caused. None of the above waivers shall extend to the rights that any party making such waiver may have to the proceeds of insurance held by OWNER as trustee or otherwise payable under any policy so issued.~~

~~B. OWNER waives all rights against CONTRACTOR, Subcontractors, ENGINEER, ENGINEER's Consultants, and the officers, directors, partners, employees, agents, and other consultants and subcontractors of each and any of them for:~~

~~1. loss due to business interruption, loss of use, or other consequential loss extending beyond direct physical loss or damage to OWNER's property or the Work caused by, arising out of, or resulting from fire or other peril whether or not insured by OWNER; and~~

~~2. loss or damage to the completed Project or part thereof caused by, arising out of, or resulting from fire or other insured peril or cause of loss covered by any property insurance maintained on the completed Project or part thereof by OWNER during partial utilization pursuant to paragraph 14.05, after Substantial Completion pursuant to paragraph 14.04, or after final payment pursuant to paragraph 14.07.~~

~~C. Any insurance policy maintained by OWNER covering any loss, damage or consequential loss referred to in paragraph 5.07.B shall contain provisions to the effect that in the event of payment of any such loss, damage, or consequential loss, the insurers will have no rights of recovery against CONTRACTOR, Subcontractors, ENGINEER, or ENGINEER's Consultants and the officers, directors, partners, employees, agents, and other consultants and subcontractors of each and any of them.~~

#### 5.08 *Receipt and Application of Insurance Proceeds*

~~A. Any insured loss under the policies of insurance required by paragraph 5.06 will be adjusted with OWNER and made payable to OWNER as fiduciary for the insureds, as their interests may appear, subject to the requirements of any applicable mortgage clause and of paragraph 5.08.B. OWNER shall deposit in a separate account any money so received and shall distribute it in accordance with such agreement as the parties in interest may reach. If no other special agreement is reached, the damaged Work shall be repaired or replaced, the monies so received applied on account thereof, and the Work and the cost thereof covered by an appropriate Change Order or Written Amendment.~~

~~B. OWNER as fiduciary shall have power to adjust and settle any loss with the insurers unless one of the parties in interest shall object in writing within 15 days after the occurrence of loss to OWNER's exercise of this power. If such objection be made, OWNER as fiduciary shall make settlement with the insurers in accordance with such agreement as the parties in interest may reach. If no such agreement among the parties in interest is reached, OWNER as fiduciary shall adjust and settle the loss with the insurers and, if required in writing by any party in interest, OWNER as fiduciary shall give bond for the proper performance of such duties.~~

#### 5.09 *Acceptance of Bonds and Insurance; Option to Replace*

A. If either OWNER or CONTRACTOR has any objection to the coverage afforded by or other provisions of the Bonds or insurance required to be purchased and maintained by the other party in accordance with Article 5 on the basis of non-conformance with the Contract Documents, the objecting party shall so notify the other party in writing within 10 days after receipt of the certificates (or other evidence requested) required by paragraph 2.05.C. OWNER and CONTRACTOR shall each provide to the other such additional information in respect of insurance provided as the other may reasonably request. If either party does not purchase or maintain all of the Bonds and insurance required of such party by the Contract Documents, such party shall notify the other party in writing of such failure to purchase prior to the start of the Work, or of such failure to maintain prior to any change in the required coverage. Without prejudice to any other right or remedy, the other party may elect to obtain equivalent Bonds or insurance to protect such other party's interests at the expense of the party who was required to provide such coverage, and a Change Order shall be issued to adjust the Contract Price accordingly.

#### 5.10 *Partial Utilization, Acknowledgment of Property Insurer*

A. If OWNER finds it necessary to occupy or use a portion or portions of the Work prior to Substantial Completion of all the Work as provided in paragraph 14.05, no such use or occupancy shall commence before the insurers providing the property insurance pursuant to paragraph 5.06 have acknowledged notice thereof and in writing effected any changes in coverage necessitated thereby. The insurers providing the property insurance shall consent by endorsement on the policy or policies, but the property insurance shall not be canceled or permitted to lapse on account of any such partial use or occupancy.

---

## ARTICLE 6 - CONTRACTOR'S RESPONSIBILITIES

---

---

## 6.01 *Supervision and Superintendence*

A. CONTRACTOR shall supervise, inspect, and direct the Work competently and efficiently, devoting such attention thereto and applying such skills and expertise as may be necessary to perform the Work in accordance with the Contract Documents. CONTRACTOR shall be solely responsible for the means, methods, techniques, sequences, and procedures of construction, but CONTRACTOR shall not be responsible for the negligence of OWNER or ENGINEER in the design or specification of a specific means, method, technique, sequence, or procedure of construction which is shown or indicated in and expressly required by the Contract Documents. CONTRACTOR shall be responsible to see that the completed Work complies accurately with the Contract Documents.

B. At all times during the progress of the Work, CONTRACTOR shall assign a competent resident superintendent thereto who shall not be replaced without written notice to OWNER and ENGINEER except under extraordinary circumstances. The superintendent will be CONTRACTOR's representative at the Site and shall have authority to act on behalf of CONTRACTOR. All communications given to or received from the superintendent shall be binding on CONTRACTOR.

## 6.02 *Labor; Working Hours*

A. CONTRACTOR shall provide competent, suitably qualified personnel to survey, lay out, and construct the Work as required by the Contract Documents. CONTRACTOR shall at all times maintain good discipline and order at the Site.

B. Except as otherwise required for the safety or protection of persons or the Work or property at the Site or adjacent thereto, and except as otherwise stated in the Contract Documents, all Work at the Site shall be performed during regular working hours, and CONTRACTOR will not permit overtime work or the performance of Work on Saturday, Sunday, or any legal holiday without OWNER's written consent (which will not be unreasonably withheld) given after prior written notice to ENGINEER.

## 6.03 *Services, Materials, and Equipment*

A. Unless otherwise specified in the General Requirements, CONTRACTOR shall provide and assume full responsibility for all services, materials, equipment, labor, transportation, construction equipment and machinery, tools, appliances, fuel, power, light, heat, telephone, water, sanitary facilities, temporary facilities, and all other facilities and incidentals necessary for the performance, testing, start-up, and completion of the Work.

B. All materials and equipment incorporated into the Work shall be as specified or, if not specified, shall be of good quality and new, except as otherwise provided in the Contract Documents. All warranties and guarantees specifically called for by the Specifications shall expressly run to the benefit of OWNER. If required by ENGINEER, CONTRACTOR shall furnish satisfactory evidence (including reports of required tests) as to the source, kind, and quality of materials and equipment. All materials and equipment shall be stored, applied, installed, connected, erected, protected, used, cleaned, and conditioned in accordance with instructions of the applicable Supplier, except as otherwise may be provided in the Contract Documents.

## 6.04 *Progress Schedule*

A. CONTRACTOR shall adhere to the progress schedule established in accordance with paragraph 2.07 as it may be adjusted from time to time as provided below.

1. CONTRACTOR shall submit to ENGINEER for acceptance (to the extent indicated in paragraph 2.07) proposed adjustments in the progress schedule that will not result in changing the Contract Times (or Milestones). Such adjustments will conform generally to the progress schedule then in effect and additionally will comply with any provisions of the General Requirements applicable thereto.

2. Proposed adjustments in the progress schedule that will change the Contract Times (or Milestones) shall be submitted in accordance with the requirements of Article 12. Such adjustments may only be made by a Change Order or Written Amendment in accordance with Article 12.

## 6.05 *Substitutes and "Or-Equals"*

A. Whenever an item of material or equipment is specified or described in the Contract Documents by using the name of a proprietary item or the name of a particular Supplier, the specification or description is intended to establish the type, function, appearance, and quality required. Unless the specification or description contains or is followed by words reading that no like, equivalent, or "or-equal" item or no substitution is permitted, other items of material or equipment or material or equipment of other Suppliers may be submitted to ENGINEER for review under the circumstances described below.

1. *"Or-Equal" Items:* If in ENGINEER's sole discretion an item of material or equipment proposed by CONTRACTOR is functionally equal to that named and sufficiently similar so that no change in related Work will be required, it may be

---

considered by ENGINEER as an “or-equal” item, in which case review and approval of the proposed item may, in ENGINEER’s sole discretion, be accomplished without compliance with some or all of the requirements for approval of proposed substitute items. For the purposes of this paragraph 6.05.A.1, a proposed item of material or equipment will be considered functionally equal to an item so named if:

a. in the exercise of reasonable judgment ENGINEER determines that: (i) it is at least equal in quality, durability, appearance, strength, and design characteristics; (ii) it will reliably perform at least equally well the function imposed by the design concept of the completed Project as a functioning whole, and;

b. CONTRACTOR certifies that: (i) there is no increase in cost to the OWNER; and (ii) it will conform substantially, even with deviations, to the detailed requirements of the item named in the Contract Documents.

## 2. Substitute Items

a. If in ENGINEER’s sole discretion an item of material or equipment proposed by CONTRACTOR does not qualify as an “or-equal” item under paragraph 6.05.A.1, it will be considered a proposed substitute item.

b. CONTRACTOR shall submit sufficient information as provided below to allow ENGINEER to determine that the item of material or equipment proposed is essentially equivalent to that named and an acceptable substitute therefor. Requests for review of proposed substitute items of material or equipment will not be accepted by ENGINEER from anyone other than CONTRACTOR.

c. The procedure for review by ENGINEER will be as set forth in paragraph 6.05.A.2.d, as supplemented in the General Requirements and as ENGINEER may decide is appropriate under the circumstances.

d. CONTRACTOR shall first make written application to ENGINEER for review of a proposed substitute item of material or equipment that CONTRACTOR seeks to furnish or use. The application shall certify that the proposed substitute item will perform adequately the functions and achieve the results called for by the general design, be similar in substance to that specified, and be suited to the same use as that specified. The application will

state the extent, if any, to which the use of the proposed substitute item will prejudice CONTRACTOR’s achievement of Substantial Completion on time, whether or not use of the proposed substitute item in the Work will require a change in any of the Contract Documents (or in the provisions of any other direct contract with OWNER for work on the Project) to adapt the design to the proposed substitute item and whether or not incorporation or use of the proposed substitute item in connection with the Work is subject to payment of any license fee or royalty. All variations of the proposed substitute item from that specified will be identified in the application, and available engineering, sales, maintenance, repair, and replacement services will be indicated. The application will also contain an itemized estimate of all costs or credits that will result directly or indirectly from use of such substitute item, including costs of redesign and claims of other contractors affected by any resulting change, all of which will be considered by ENGINEER in evaluating the proposed substitute item. ENGINEER may require CONTRACTOR to furnish additional data about the proposed substitute item.

*B. Substitute Construction Methods or Procedures:* If a specific means, method, technique, sequence, or procedure of construction is shown or indicated in and expressly required by the Contract Documents, CONTRACTOR may furnish or utilize a substitute means, method, technique, sequence, or procedure of construction approved by ENGINEER. CONTRACTOR shall submit sufficient information to allow ENGINEER, in ENGINEER’s sole discretion, to determine that the substitute proposed is equivalent to that expressly called for by the Contract Documents. The procedure for review by ENGINEER will be similar to that provided in subparagraph 6.05.A.2.

*C. Engineer’s Evaluation:* ENGINEER will be allowed a reasonable time within which to evaluate each proposal or submittal made pursuant to paragraphs 6.05.A and 6.05.B. ENGINEER will be the sole judge of acceptability. No “or-equal” or substitute will be ordered, installed or utilized until ENGINEER’s review is complete, which will be evidenced by either a Change Order for a substitute or an approved Shop Drawing for an “or equal.” ENGINEER will advise CONTRACTOR in writing of any negative determination.

*D. Special Guarantee:* OWNER may require CONTRACTOR to furnish at CONTRACTOR’s expense a special performance guarantee or other surety with respect to any substitute.

---

E. *ENGINEER's Cost Reimbursement:* ENGINEER will record time required by ENGINEER and ENGINEER's Consultants in evaluating substitute proposed or submitted by CONTRACTOR pursuant to paragraphs 6.05.A.2 and 6.05.B and in making changes in the Contract Documents (or in the provisions of any other direct contract with OWNER for work on the Project) occasioned thereby. Whether or not ENGINEER approves a substitute item so proposed or submitted by CONTRACTOR, CONTRACTOR shall reimburse OWNER for the charges of ENGINEER and ENGINEER's Consultants for evaluating each such proposed substitute.

F. *CONTRACTOR's Expense:* CONTRACTOR shall provide all data in support of any proposed substitute or "or-equal" at CONTRACTOR's expense.

#### 6.06 *Concerning Subcontractors, Suppliers, and Others*

A. CONTRACTOR shall not employ any Subcontractor, Supplier, or other individual or entity (including those acceptable to OWNER as indicated in paragraph 6.06.B), whether initially or as a replacement, against whom OWNER may have reasonable objection. CONTRACTOR shall not be required to employ any Subcontractor, Supplier, or other individual or entity to furnish or perform any of the Work against whom CONTRACTOR has reasonable objection.

#### *SEE ALSO SUPPLEMENTARY CONDITIONS (SECTION 00800)*

B. If the Supplementary Conditions require the identity of certain Subcontractors, Suppliers, or other individuals or entities to be submitted to OWNER in advance for acceptance by OWNER by a specified date prior to the Effective Date of the Agreement, and if CONTRACTOR has submitted a list thereof in accordance with the Supplementary Conditions, OWNER's acceptance (either in writing or by failing to make written objection thereto by the date indicated for acceptance or objection in the Bidding Documents or the Contract Documents) of any such Subcontractor, Supplier, or other individual or entity so identified may be revoked on the basis of reasonable objection after due investigation. CONTRACTOR shall submit an acceptable replacement for the rejected Subcontractor, Supplier, or other individual or entity, and the Contract Price will be adjusted by the difference in the cost occasioned by such replacement, and an appropriate Change Order will be issued or Written Amendment signed. No acceptance by OWNER of any such Subcontractor, Supplier, or other individual or entity, whether initially or as a replacement, shall constitute a waiver of any right of OWNER or ENGINEER to reject defective Work.

#### *SEE ALSO SUPPLEMENTARY CONDITIONS (SECTION 00800)*

C. CONTRACTOR shall be fully responsible to OWNER and ENGINEER for all acts and omissions of the Subcontractors, Suppliers, and other individuals or entities performing or furnishing any of the Work just as CONTRACTOR is responsible for CONTRACTOR's own acts and omissions. Nothing in the Contract Documents shall create for the benefit of any such Subcontractor, Supplier, or other individual or entity any contractual relationship between OWNER or ENGINEER and any such Subcontractor, Supplier or other individual or entity, nor shall it create any obligation on the part of OWNER or ENGINEER to pay or to see to the payment of any moneys due any such Subcontractor, Supplier, or other individual or entity except as may otherwise be required by Laws and Regulations.

D. CONTRACTOR shall be solely responsible for scheduling and coordinating the Work of Subcontractors, Suppliers, and other individuals or entities performing or furnishing any of the Work under a direct or indirect contract with CONTRACTOR.

E. CONTRACTOR shall require all Subcontractors, Suppliers, and such other individuals or entities performing or furnishing any of the Work to communicate with ENGINEER through CONTRACTOR.

F. The divisions and sections of the Specifications and the identifications of any Drawings shall not control CONTRACTOR in dividing the Work among Subcontractors or Suppliers or delineating the Work to be performed by any specific trade.

G. All Work performed for CONTRACTOR by a Subcontractor or Supplier will be pursuant to an appropriate agreement between CONTRACTOR and the Subcontractor or Supplier which specifically binds the Subcontractor or Supplier to the applicable terms and conditions of the Contract Documents for the benefit of OWNER and ENGINEER. Whenever any such agreement is with a Subcontractor or Supplier who is listed as an additional insured on the property insurance provided in paragraph 5.06, the agreement between the CONTRACTOR and the Subcontractor or Supplier will contain provisions whereby the Subcontractor or Supplier waives all rights against OWNER, CONTRACTOR, ENGINEER, ENGINEER's Consultants, and all other individuals or entities identified in the Supplementary Conditions to be listed as insureds or additional insureds (and the officers, directors, partners, employees, agents, and other consultants and subcontractors of each and any of them) for all losses and damages caused by, arising out of, relating to, or resulting from any of the perils or causes of loss covered by such policies and any other property insurance applicable to the Work. If the insurers on any such policies require separate waiver forms to be signed by any Subcontractor or Supplier, CONTRACTOR will obtain the same.

---

#### 6.07 *Patent Fees and Royalties*

A. CONTRACTOR shall pay all license fees and royalties and assume all costs incident to the use in the performance of the Work or the incorporation in the Work of any invention, design, process, product, or device which is the subject of patent rights or copyrights held by others. If a particular invention, design, process, product, or device is specified in the Contract Documents for use in the performance of the Work and if to the actual knowledge of OWNER or ENGINEER its use is subject to patent rights or copyrights calling for the payment of any license fee or royalty to others, the existence of such rights shall be disclosed by OWNER in the Contract Documents. To the fullest extent permitted by Laws and Regulations, CONTRACTOR shall indemnify and hold harmless OWNER, ENGINEER, ENGINEER's Consultants, and the officers, directors, partners, employees or agents, and other consultants of each and any of them from and against all claims, costs, losses, and damages (including but not limited to all fees and charges of engineers, architects, attorneys, and other professionals and all court or arbitration or other dispute resolution costs) arising out of or relating to any infringement of patent rights or copyrights incident to the use in the performance of the Work or resulting from the incorporation in the Work of any invention, design, process, product, or device not specified in the Contract Documents.

#### 6.08 *Permits*

A. Unless otherwise provided in the Supplementary Conditions, CONTRACTOR shall obtain and pay for all construction permits and licenses. OWNER shall assist CONTRACTOR, when necessary, in obtaining such permits and licenses. CONTRACTOR shall pay all governmental charges and inspection fees necessary for the prosecution of the Work which are applicable at the time of opening of Bids, or, if there are no Bids, on the Effective Date of the Agreement. CONTRACTOR shall pay all charges of utility owners for connections to the Work, and OWNER shall pay all charges of such utility owners for capital costs related thereto, such as plant investment fees.

#### 6.09 *Laws and Regulations*

A. CONTRACTOR shall give all notices and comply with all Laws and Regulations applicable to the performance of the Work. Except where otherwise expressly required by applicable Laws and Regulations, neither OWNER nor ENGINEER shall be responsible for monitoring CONTRACTOR's compliance with any Laws or Regulations.

B. If CONTRACTOR performs any Work knowing or having reason to know that it is contrary to Laws or Regulations, CONTRACTOR shall bear all claims, costs,

losses, and damages (including but not limited to all fees and charges of engineers, architects, attorneys, and other professionals and all court or arbitration or other dispute resolution costs) arising out of or relating to such Work; however, it shall not be CONTRACTOR's primary responsibility to make certain that the Specifications and Drawings are in accordance with Laws and Regulations, but this shall not relieve CONTRACTOR of CONTRACTOR's obligations under paragraph 3.03.

C. Changes in Laws or Regulations not known at the time of opening of Bids (or, on the Effective Date of the Agreement if there were no Bids) having an effect on the cost or time of performance of the Work may be the subject of an adjustment in Contract Price or Contract Times. If OWNER and CONTRACTOR are unable to agree on entitlement to or on the amount or extent, if any, of any such adjustment, a Claim may be made therefore as provided in paragraph 10.05.

#### 6.10 *Taxes*

A. CONTRACTOR shall pay all sales, consumer, use, and other similar taxes required to be paid by CONTRACTOR in accordance with the Laws and Regulations of the place of the Project which are applicable during the performance of the Work.

#### 6.11 *Use of Site and Other Areas*

##### A. *Limitation on Use of Site and Other Areas*

1. CONTRACTOR shall confine construction equipment, the storage of materials and equipment, and the operations of workers to the Site and other areas permitted by Laws and Regulations, and shall not unreasonably encumber the Site and other areas with construction equipment or other materials or equipment. CONTRACTOR shall assume full responsibility for any damage to any such land or area, or to the owner or occupant thereof, or of any adjacent land or areas resulting from the performance of the Work.

2. Should any claim be made by any such owner or occupant because of the performance of the Work, CONTRACTOR shall promptly settle with such other party by negotiation or otherwise resolve the claim by arbitration or other dispute resolution proceeding or at law.

3. To the fullest extent permitted by Laws and Regulations, CONTRACTOR shall indemnify and hold harmless OWNER, ENGINEER, ENGINEER's Consultant, and the officers, directors, partners, employees, agents, and other consultants of each and any of them from and against all claims, costs, losses, and damages

---

(including but not limited to all fees and charges of engineers, architects, attorneys, and other professionals and all court or arbitration or other dispute resolution costs) arising out of or relating to any claim or action, legal or equitable, brought by any such owner or occupant against OWNER, ENGINEER, or any other party indemnified hereunder to the extent caused by or based upon CONTRACTOR's performance of the Work.

B. *Removal of Debris During Performance of the Work:* During the progress of the Work CONTRACTOR shall keep the Site and other areas free from accumulations of waste materials, rubbish, and other debris. Removal and disposal of such waste materials, rubbish, and other debris shall conform to applicable Laws and Regulations.

C. *Cleaning:* Prior to Substantial Completion of the Work CONTRACTOR shall clean the Site and make it ready for utilization by OWNER. At the completion of the Work CONTRACTOR shall remove from the Site all tools, appliances, construction equipment and machinery, and surplus materials and shall restore to original condition all property not designated for alteration by the Contract Documents.

D. *Loading Structures:* CONTRACTOR shall not load nor permit any part of any structure to be loaded in any manner that will endanger the structure, nor shall CONTRACTOR subject any part of the Work or adjacent property to stresses or pressures that will endanger it.

#### 6.12 *Record Documents*

A. CONTRACTOR shall maintain in a safe place at the Site one record copy of all Drawings, Specifications, Addenda, Written Amendments, Change Orders, Work Change Directives, Field Orders, and written interpretations and clarifications in good order and annotated to show changes made during construction. These record documents together with all approved Samples and a counterpart of all approved Shop Drawings will be available to ENGINEER for reference. Upon completion of the Work, these record documents, Samples, and Shop Drawings will be delivered to ENGINEER for OWNER.

#### 6.13 *Safety and Protection*

*SEE ALSO SUPPLEMENTARY CONDITIONS (SECTION 00800)*

A. CONTRACTOR shall be solely responsible for initiating, maintaining and supervising all safety precautions and programs in connection with the Work. CONTRACTOR shall take all necessary precautions for the safety of, and shall provide the necessary protection to prevent damage, injury or loss to:

1. all persons on the Site or who may be affected by the Work;

2. all the Work and materials and equipment to be incorporated therein, whether in storage on or off the Site; and

3. other property at the Site or adjacent thereto, including trees, shrubs, lawns, walks, pavements, roadways, structures, utilities, and Underground Facilities not designated for removal, relocation, or replacement in the course of construction.

B. CONTRACTOR shall comply with all applicable Laws and Regulations relating to the safety of persons or property, or to the protection of persons or property from damage, injury, or loss; and shall erect and maintain all necessary safeguards for such safety and protection. CONTRACTOR shall notify owners of adjacent property and of Underground Facilities and other utility owners when prosecution of the Work may affect them, and shall cooperate with them in the protection, removal, relocation, and replacement of their property. All damage, injury, or loss to any property referred to in paragraph 6.13.A.2 or 6.13.A.3 caused, directly or indirectly, in whole or in part, by CONTRACTOR, any Subcontractor, Supplier, or any other individual or entity directly or indirectly employed by any of them to perform any of the Work, or anyone for whose acts any of them may be liable, shall be remedied by CONTRACTOR (except damage or loss attributable to the fault of Drawings or Specifications or to the acts or omissions of OWNER or ENGINEER or ENGINEER's Consultant, or anyone employed by any of them, or anyone for whose acts any of them may be liable, and not attributable, directly or indirectly, in whole or in part, to the fault or negligence of CONTRACTOR or any Subcontractor, Supplier, or other individual or entity directly or indirectly employed by any of them). CONTRACTOR's duties and responsibilities for safety and for protection of the Work shall continue until such time as all the Work is completed and ENGINEER has issued a notice to OWNER and CONTRACTOR in accordance with paragraph 14.07.B that the Work is acceptable (except as otherwise expressly provided in connection with Substantial Completion).

#### 6.14 *Safety Representative*

A. CONTRACTOR shall designate a qualified and experienced safety representative at the Site whose duties and responsibilities shall be the prevention of accidents and the maintaining and supervising of safety precautions and programs.

A. CONTRACTOR shall be responsible for coordinating any exchange of material safety data sheets or other hazard communication information required to be made available to or exchanged between or among employers at the Site in accordance with Laws or Regulations.

6.16 *Emergencies*

A. In emergencies affecting the safety or protection of persons or the Work or property at the Site or adjacent thereto, CONTRACTOR is obligated to act to prevent threatened damage, injury, or loss. CONTRACTOR shall give ENGINEER prompt written notice if CONTRACTOR believes that any significant changes in the Work or variations from the Contract Documents have been caused thereby or are required as a result thereof. If ENGINEER determines that a change in the Contract Documents is required because of the action taken by CONTRACTOR in response to such an emergency, a Work Change Directive or Change Order will be issued.

6.17 *Shop Drawings and Samples*

A. CONTRACTOR shall submit Shop Drawings to ENGINEER for review and approval in accordance with the acceptable schedule of Shop Drawings and Sample submittals. All submittals will be identified as ENGINEER may require and in the number of copies specified in the General Requirements. The data shown on the Shop Drawings will be complete with respect to quantities, dimensions, specified performance and design criteria, materials, and similar data to show ENGINEER the services, materials, and equipment CONTRACTOR proposes to provide and to enable ENGINEER to review the information for the limited purposes required by paragraph 6.17.E.

B. CONTRACTOR shall also submit Samples to ENGINEER for review and approval in accordance with the acceptable schedule of Shop Drawings and Sample submittals. Each Sample will be identified clearly as to material, Supplier, pertinent data such as catalog numbers, and the use for which intended and otherwise as ENGINEER may require to enable ENGINEER to review the submittal for the limited purposes required by paragraph 6.17.E. The numbers of each Sample to be submitted will be as specified in the Specifications.

C. Where a Shop Drawing or Sample is required by the Contract Documents or the schedule of Shop Drawings and Sample submittals acceptable to ENGINEER as required by paragraph 2.07, any related Work performed prior to ENGINEER's review and approval of the pertinent submittal will be at the sole expense and responsibility of CONTRACTOR.

D. *Submittal Procedures*

1. Before submitting each Shop Drawing or Sample, CONTRACTOR shall have determined and verified:

a. all field measurements, quantities, dimensions, specified performance criteria, installation requirements, materials, catalog numbers, and similar information with respect thereto;

b. all materials with respect to intended use, fabrication, shipping, handling, storage, assembly, and installation pertaining to the performance of the Work;

c. all information relative to means, methods, techniques, sequences, and procedures of construction and safety precautions and programs incident thereto; and

d. CONTRACTOR shall also have reviewed and coordinated each Shop Drawing or Sample with other Shop Drawings and Samples and with the requirements of the Work and the Contract Documents.

2. Each submittal shall bear a stamp or specific written indication that CONTRACTOR has satisfied CONTRACTOR's obligations under the Contract Documents with respect to CONTRACTOR's review and approval of that submittal.

3. At the time of each submittal, CONTRACTOR shall give ENGINEER specific written notice of such variations, if any, that the Shop Drawing or Sample submitted may have from the requirements of the Contract Documents, such notice to be in a written communication separate from the submittal; and, in addition, shall cause a specific notation to be made on each Shop Drawing and Sample submitted to ENGINEER for review and approval of each such variation.

E. *ENGINEER's Review*

1. ENGINEER will timely review and approve Shop Drawings and Samples in accordance with the schedule of Shop Drawings and Sample submittals acceptable to ENGINEER. ENGINEER's review and approval will be only to determine if the items covered by the submittals will, after installation or incorporation in the Work, conform to the information given in the Contract Documents and be compatible with the design

---

concept of the completed Project as a functioning whole as indicated by the Contract Documents.

2. ENGINEER's review and approval will not extend to means, methods, techniques, sequences, or procedures of construction (except where a particular means, method, technique, sequence, or procedure of construction is specifically and expressly called for by the Contract Documents) or to safety precautions or programs incident thereto. The review and approval of a separate item as such will not indicate approval of the assembly in which the item functions.

3. ENGINEER's review and approval of Shop Drawings or Samples shall not relieve CONTRACTOR from responsibility for any variation from the requirements of the Contract Documents unless CONTRACTOR has in writing called ENGINEER's attention to each such variation at the time of each submittal as required by paragraph 6.17.D.3 and ENGINEER has given written approval of each such variation by specific written notation thereof incorporated in or accompanying the Shop Drawing or Sample approval; nor will any approval by ENGINEER relieve CONTRACTOR from responsibility for complying with the requirements of paragraph 6.17.D.1.

#### F. *Resubmittal Procedures*

1. CONTRACTOR shall make corrections required by ENGINEER and shall return the required number of corrected copies of Shop Drawings and submit as required new Samples for review and approval. CONTRACTOR shall direct specific attention in writing to revisions other than the corrections called for by ENGINEER on previous submittals.

#### 6.18 *Continuing the Work*

A. CONTRACTOR shall carry on the Work and adhere to the progress schedule during all disputes or disagreements with OWNER. No Work shall be delayed or postponed pending resolution of any disputes or disagreements, except as permitted by paragraph 15.04 or as OWNER and CONTRACTOR may otherwise agree in writing.

#### 6.19 *CONTRACTOR's General Warranty and Guarantee*

A. CONTRACTOR warrants and guarantees to OWNER, ENGINEER, and ENGINEER's Consultants that all Work will be in accordance with the Contract Documents and will not be defective. CONTRACTOR's

warranty and guarantee hereunder excludes defects or damage caused by:

1. abuse, modification, or improper maintenance or operation by persons other than CONTRACTOR, Subcontractors, Suppliers, or any other individual or entity for whom CONTRACTOR is responsible; or

2. normal wear and tear under normal usage.

B. CONTRACTOR's obligation to perform and complete the Work in accordance with the Contract Documents shall be absolute. None of the following will constitute an acceptance of Work that is not in accordance with the Contract Documents or a release of CONTRACTOR's obligation to perform the Work in accordance with the Contract Documents:

1. observations by ENGINEER;

2. recommendation by ENGINEER or payment by OWNER of any progress or final payment;

3. the issuance of a certificate of Substantial Completion by ENGINEER or any payment related thereto by OWNER;

4. use or occupancy of the Work or any part thereof by OWNER;

5. any acceptance by OWNER or any failure to do so;

6. any review and approval of a Shop Drawing or Sample submittal or the issuance of a notice of acceptability by ENGINEER;

7. any inspection, test, or approval by others; or

8. any correction of defective Work by OWNER.

#### 6.20 *Indemnification*

A. To the fullest extent permitted by Laws and Regulations, CONTRACTOR shall indemnify and hold harmless OWNER, ENGINEER, ENGINEER's Consultants, and the officers, directors, partners, employees, agents, and other consultants and subcontractors of each and any of them from and against all claims, costs, losses, and damages (including but not limited to all fees and charges of engineers, architects, attorneys, and other professionals and all court or arbitration or other dispute resolution costs) arising out of or relating to the perfor-



mance of the Work, provided that any such claim, cost, loss, or damage:

1. is attributable to bodily injury, sickness, disease, or death, or to injury to or destruction of tangible property (other than the Work itself), including the loss of use resulting therefrom; and

2. is caused in whole or in part by any negligent act or omission of CONTRACTOR, any Subcontractor, any Supplier, or any individual or entity directly or indirectly employed by any of them to perform any of the Work or anyone for whose acts any of them may be liable, regardless of whether or not caused in part by any negligence or omission of an individual or entity indemnified hereunder or whether liability is imposed upon such indemnified party by Laws and Regulations regardless of the negligence of any such individual or entity.

B. In any and all claims against OWNER or ENGINEER or any of their respective consultants, agents, officers, directors, partners, or employees by any employee (or the survivor or personal representative of such employee) of CONTRACTOR, any Subcontractor, any Supplier, or any individual or entity directly or indirectly employed by any of them to perform any of the Work, or anyone for whose acts any of them may be liable, the indemnification obligation under paragraph 6.20.A shall not be limited in any way by any limitation on the amount or type of damages, compensation, or benefits payable by or for CONTRACTOR or any such Subcontractor, Supplier, or other individual or entity under workers' compensation acts, disability benefit acts, or other employee benefit acts.

C. The indemnification obligations of CONTRACTOR under paragraph 6.20.A shall not extend to the liability of ENGINEER and ENGINEER's Consultants or to the officers, directors, partners, employees, agents, and other consultants and subcontractors of each and any of them arising out of:

1. the preparation or approval of, or the failure to prepare or approve, maps, Drawings, opinions, reports, surveys, Change Orders, designs, or Specifications; or

2. giving directions or instructions, or failing to give them, if that is the primary cause of the injury or damage.

---

## ARTICLE 7 - OTHER WORK

---

### 7.01 *Related Work at Site*

A. OWNER may perform other work related to the Project at the Site by OWNER's employees, or let other direct contracts therefor, or have other work performed by utility owners. If such other work is not noted in the Contract Documents, then:

1. written notice thereof will be given to CONTRACTOR prior to starting any such other work; and

2. if OWNER and CONTRACTOR are unable to agree on entitlement to or on the amount or extent, if any, of any adjustment in the Contract Price or Contract Times that should be allowed as a result of such other work, a Claim may be made therefore as provided in paragraph 10.05.

B. CONTRACTOR shall afford each other contractor who is a party to such a direct contract and each utility owner (and OWNER, if OWNER is performing the other work with OWNER's employees) proper and safe access to the Site and a reasonable opportunity for the introduction and storage of materials and equipment and the execution of such other work and shall properly coordinate the Work with theirs. Unless otherwise provided in the Contract Documents, CONTRACTOR shall do all cutting, fitting, and patching of the Work that may be required to properly connect or otherwise make its several parts come together and properly integrate with such other work. CONTRACTOR shall not endanger any work of others by cutting, excavating, or otherwise altering their work and will only cut or alter their work with the written consent of ENGINEER and the others whose work will be affected. The duties and responsibilities of CONTRACTOR under this paragraph are for the benefit of such utility owners and other contractors to the extent that there are comparable provisions for the benefit of CONTRACTOR in said direct contracts between OWNER and such utility owners and other contractors.

C. If the proper execution or results of any part of CONTRACTOR's Work depends upon work performed by others under this Article 7, CONTRACTOR shall inspect such other work and promptly report to ENGINEER in writing any delays, defects, or deficiencies in such other work that render it unavailable or unsuitable for the proper execution and results of CONTRACTOR's Work. CONTRACTOR's failure to so report will constitute an acceptance of such other work as fit and proper for integration with CONTRACTOR's Work except for latent defects and deficiencies in such other work.

---

7.02 *Coordination*

A. If OWNER intends to contract with others for the performance of other work on the Project at the Site, the following will be set forth in Supplementary Conditions:

1. the individual or entity who will have authority and responsibility for coordination of the activities among the various contractors will be identified;
2. the specific matters to be covered by such authority and responsibility will be itemized; and
3. the extent of such authority and responsibilities will be provided.

B. Unless otherwise provided in the Supplementary Conditions, OWNER shall have sole authority and responsibility for such coordination.

ARTICLE 8 - OWNER'S RESPONSIBILITIES

---

8.01 *Communications to Contractor*

A. Except as otherwise provided in these General Conditions, OWNER shall issue all communications to CONTRACTOR through ENGINEER.

8.02 *Replacement of ENGINEER*

A. In case of termination of the employment of ENGINEER, OWNER shall appoint an engineer to whom CONTRACTOR makes no reasonable objection, whose status under the Contract Documents shall be that of the former ENGINEER.

8.03 *Furnish Data*

A. OWNER shall promptly furnish the data required of OWNER under the Contract Documents.

8.04 *Pay Promptly When Due*

A. OWNER shall make payments to CONTRACTOR promptly when they are due as provided in paragraphs 14.02.C and 14.07.C.

8.05 *Lands and Easements; Reports and Tests*

A. OWNER's duties in respect of providing lands and easements and providing engineering surveys to establish reference points are set forth in paragraphs 4.01 and 4.05. Paragraph 4.02 refers to OWNER's identifying and making available to CONTRACTOR copies of reports

of explorations and tests of subsurface conditions and drawings of physical conditions in or relating to existing surface or subsurface structures at or contiguous to the Site that have been utilized by ENGINEER in preparing the Contract Documents.

8.06 *Insurance*

A. OWNER's responsibilities, if any, in respect to purchasing and maintaining liability and property insurance are set forth in Article 5.

8.07 *Change Orders*

A. OWNER is obligated to execute Change Orders as indicated in paragraph 10.03.

8.08 *Inspections, Tests, and Approvals*

A. OWNER's responsibility in respect to certain inspections, tests, and approvals is set forth in paragraph 13.03.B.

8.09 *Limitations on OWNER's Responsibilities*

A. The OWNER shall not supervise, direct, or have control or authority over, nor be responsible for, CONTRACTOR's means, methods, techniques, sequences, or procedures of construction, or the safety precautions and programs incident thereto, or for any failure of CONTRACTOR to comply with Laws and Regulations applicable to the performance of the Work. OWNER will not be responsible for CONTRACTOR's failure to perform the Work in accordance with the Contract Documents.

8.10 *Undisclosed Hazardous Environmental Condition*

A. OWNER's responsibility in respect to an undisclosed Hazardous Environmental Condition is set forth in paragraph 4.06.

8.11 *Evidence of Financial Arrangements*

A. If and to the extent OWNER has agreed to furnish CONTRACTOR reasonable evidence that financial arrangements have been made to satisfy OWNER's obligations under the Contract Documents, OWNER's responsibility in respect thereof will be as set forth in the Supplementary Conditions.

---

ARTICLE 9 - ENGINEER'S STATUS DURING  
CONSTRUCTION

---

9.01 *OWNER'S Representative*

A. ENGINEER will be OWNER's representative during the construction period. The duties and responsibilities and the limitations of authority of ENGINEER as OWNER's representative during construction are set forth in the Contract Documents and will not be changed without written consent of OWNER and ENGINEER.

9.02 *Visits to Site*

A. ENGINEER will make visits to the Site at intervals appropriate to the various stages of construction as ENGINEER deems necessary in order to observe as an experienced and qualified design professional the progress that has been made and the quality of the various aspects of CONTRACTOR's executed Work. Based on information obtained during such visits and observations, ENGINEER, for the benefit of OWNER, will determine, in general, if the Work is proceeding in accordance with the Contract Documents. ENGINEER will not be required to make exhaustive or continuous inspections on the Site to check the quality or quantity of the Work. ENGINEER's efforts will be directed toward providing for OWNER a greater degree of confidence that the completed Work will conform generally to the Contract Documents. On the basis of such visits and observations, ENGINEER will keep OWNER informed of the progress of the Work and will endeavor to guard OWNER against defective Work.

B. ENGINEER's visits and observations are subject to all the limitations on ENGINEER's authority and responsibility set forth in paragraph 9.10, and particularly, but without limitation, during or as a result of ENGINEER's visits or observations of CONTRACTOR's Work ENGINEER will not supervise, direct, control, or have authority over or be responsible for CONTRACTOR's means, methods, techniques, sequences, or procedures of construction, or the safety precautions and programs incident thereto, or for any failure of CONTRACTOR to comply with Laws and Regulations applicable to the performance of the Work.

9.03 *Project Representative*

A. If OWNER and ENGINEER agree, ENGINEER will furnish a Resident Project Representative to assist ENGINEER in providing more extensive observation of the Work. The responsibilities and authority and limitations thereon of any such Resident Project Representative and assistants will be as provided in paragraph 9.10 and in the Supplementary Conditions. If OWNER designates another representative or agent to represent OWNER at the Site who is not ENGINEER's Consultant, agent or employee,

the responsibilities and authority and limitations thereon of such other individual or entity will be as provided in the Supplementary Conditions.

9.04 *Clarifications and Interpretations*

A. ENGINEER will issue with reasonable promptness such written clarifications or interpretations of the requirements of the Contract Documents as ENGINEER may determine necessary, which shall be consistent with the intent of and reasonably inferable from the Contract Documents. Such written clarifications and interpretations will be binding on OWNER and CONTRACTOR. If OWNER and CONTRACTOR are unable to agree on entitlement to or on the amount or extent, if any, of any adjustment in the Contract Price or Contract Times, or both, that should be allowed as a result of a written clarification or interpretation, a Claim may be made therefor as provided in paragraph 10.05.

9.05 *Authorized Variations in Work*

A. ENGINEER may authorize minor variations in the Work from the requirements of the Contract Documents which do not involve an adjustment in the Contract Price or the Contract Times and are compatible with the design concept of the completed Project as a functioning whole as indicated by the Contract Documents. These may be accomplished by a Field Order and will be binding on OWNER and also on CONTRACTOR, who shall perform the Work involved promptly. If OWNER and CONTRACTOR are unable to agree on entitlement to or on the amount or extent, if any, of any adjustment in the Contract Price or Contract Times, or both, as a result of a Field Order, a Claim may be made therefor as provided in paragraph 10.05.

9.06 *Rejecting Defective Work*

A. ENGINEER will have authority to disapprove or reject Work which ENGINEER believes to be defective, or that ENGINEER believes will not produce a completed Project that conforms to the Contract Documents or that will prejudice the integrity of the design concept of the completed Project as a functioning whole as indicated by the Contract Documents. ENGINEER will also have authority to require special inspection or testing of the Work as provided in paragraph 13.04, whether or not the Work is fabricated, installed, or completed.

9.07 *Shop Drawings, Change Orders and Payments*

A. In connection with ENGINEER's authority as to Shop Drawings and Samples, see paragraph 6.17.

B. In connection with ENGINEER's authority as to Change Orders, see Articles 10, 11, and 12.

---

C. In connection with ENGINEER's authority as to Applications for Payment, see Article 14.

9.08 *Determinations for Unit Price Work*

A. ENGINEER will determine the actual quantities and classifications of Unit Price Work performed by CONTRACTOR. ENGINEER will review with CONTRACTOR the ENGINEER's preliminary determinations on such matters before rendering a written decision thereon (by recommendation of an Application for Payment or otherwise). ENGINEER's written decision thereon will be final and binding (except as modified by ENGINEER to reflect changed factual conditions or more accurate data) upon OWNER and CONTRACTOR, subject to the provisions of paragraph 10.05.

9.09 *Decisions on Requirements of Contract Documents and Acceptability of Work*

A. ENGINEER will be the initial interpreter of the requirements of the Contract Documents and judge of the acceptability of the Work there under. Claims, disputes and other matters relating to the acceptability of the Work, the quantities and classifications of Unit Price Work, the interpretation of the requirements of the Contract Documents pertaining to the performance of the Work, and Claims seeking changes in the Contract Price or Contract Times will be referred initially to ENGINEER in writing, in accordance with the provisions of paragraph 10.05, with a request for a formal decision.

B. When functioning as interpreter and judge under this paragraph 9.09, ENGINEER will not show partiality to OWNER or CONTRACTOR and will not be liable in connection with any interpretation or decision rendered in good faith in such capacity. The rendering of a decision by ENGINEER pursuant to this paragraph 9.09 with respect to any such Claim, dispute, or other matter (except any which have been waived by the making or acceptance of final payment as provided in paragraph 14.07) will be a condition precedent to any exercise by OWNER or CONTRACTOR of such rights or remedies as either may otherwise have under the Contract Documents or by Laws or Regulations in respect of any such Claim, dispute, or other matter.

9.10 *Limitations on ENGINEER's Authority and Responsibilities*

A. Neither ENGINEER's authority or responsibility under this Article 9 or under any other provision of the Contract Documents nor any decision made by ENGINEER in good faith either to exercise or not exercise such authority or responsibility or the undertaking, exercise, or performance of any authority or responsibility by ENGINEER shall create, impose, or give rise to any duty in contract, tort, or otherwise owed by ENGINEER to

CONTRACTOR, any Subcontractor, any Supplier, any other individual or entity, or to any surety for or employee or agent of any of them.

B. ENGINEER will not supervise, direct, control, or have authority over or be responsible for CONTRACTOR's means, methods, techniques, sequences, or procedures of construction, or the safety precautions and programs incident thereto, or for any failure of CONTRACTOR to comply with Laws and Regulations applicable to the performance of the Work. ENGINEER will not be responsible for CONTRACTOR's failure to perform the Work in accordance with the Contract Documents.

C. ENGINEER will not be responsible for the acts or omissions of CONTRACTOR or of any Subcontractor, any Supplier, or of any other individual or entity performing any of the Work.

D. ENGINEER's review of the final Application for Payment and accompanying documentation and all maintenance and operating instructions, schedules, guarantees, Bonds, certificates of inspection, tests and approvals, and other documentation required to be delivered by paragraph 14.07.A will only be to determine generally that their content complies with the requirements of, and in the case of certificates of inspections, tests, and approvals that the results certified indicate compliance with, the Contract Documents.

E. The limitations upon authority and responsibility set forth in this paragraph 9.10 shall also apply to ENGINEER's Consultants, Resident Project Representative, and assistants.

ARTICLE 10 - CHANGES IN THE WORK; CLAIMS

---

10.01 *Authorized Changes in the Work*

A. Without invalidating the Agreement and without notice to any surety, OWNER may, at any time or from time to time, order additions, deletions, or revisions in the Work by a Written Amendment, a Change Order, or a Work Change Directive. Upon receipt of any such document, CONTRACTOR shall promptly proceed with the Work involved which will be performed under the applicable conditions of the Contract Documents (except as otherwise specifically provided).

B. If OWNER and CONTRACTOR are unable to agree on entitlement to, or on the amount or extent, if any, of an adjustment in the Contract Price or Contract Times, or both, that should be allowed as a result of a Work Change Directive, a Claim may be made therefore as provided in paragraph 10.05.

---

#### 10.02 *Unauthorized Changes in the Work*

A. CONTRACTOR shall not be entitled to an increase in the Contract Price or an extension of the Contract Times with respect to any work performed that is not required by the Contract Documents as amended, modified, or supplemented as provided in paragraph 3.04, except in the case of an emergency as provided in paragraph 6.16 or in the case of uncovering Work as provided in paragraph 13.04.B.

#### 10.03 *Execution of Change Orders*

A. OWNER and CONTRACTOR shall execute appropriate Change Orders recommended by ENGINEER (or Written Amendments) covering:

1. changes in the Work which are: (i) ordered by OWNER pursuant to paragraph 10.01.A, (ii) required because of acceptance of defective Work under paragraph 13.08.A or OWNER's correction of defective Work under paragraph 13.09, or (iii) agreed to by the parties;

2. changes in the Contract Price or Contract Times which are agreed to by the parties, including any undisputed sum or amount of time for Work actually performed in accordance with a Work Change Directive; and

3. changes in the Contract Price or Contract Times which embody the substance of any written decision rendered by ENGINEER pursuant to paragraph 10.05; provided that, in lieu of executing any such Change Order, an appeal may be taken from any such decision in accordance with the provisions of the Contract Documents and applicable Laws and Regulations, but during any such appeal, CONTRACTOR shall carry on the Work and adhere to the progress schedule as provided in paragraph 6.18.A.

#### 10.04 *Notification to Surety*

A. If notice of any change affecting the general scope of the Work or the provisions of the Contract Documents (including, but not limited to, Contract Price or Contract Times) is required by the provisions of any Bond to be given to a surety, the giving of any such notice will be CONTRACTOR's responsibility. The amount of each applicable Bond will be adjusted to reflect the effect of any such change.

#### 10.05 *Claims and Disputes*

A. *Notice:* Written notice stating the general nature of each Claim, dispute, or other matter shall be delivered by the claimant to ENGINEER and the other party to the

Contract promptly (but in no event later than 30 days) after the start of the event giving rise thereto. Notice of the amount or extent of the Claim, dispute, or other matter with supporting data shall be delivered to the ENGINEER and the other party to the Contract within 60 days after the start of such event (unless ENGINEER allows additional time for claimant to submit additional or more accurate data in support of such Claim, dispute, or other matter). A Claim for an adjustment in Contract Price shall be prepared in accordance with the provisions of paragraph 12.01.B. A Claim for an adjustment in Contract Time shall be prepared in accordance with the provisions of paragraph 12.02.B. Each Claim shall be accompanied by claimant's written statement that the adjustment claimed is the entire adjustment to which the claimant believes it is entitled as a result of said event. The opposing party shall submit any response to ENGINEER and the claimant within 30 days after receipt of the claimant's last submittal (unless ENGINEER allows additional time).

B. *ENGINEER's Decision:* ENGINEER will render a formal decision in writing within 30 days after receipt of the last submittal of the claimant or the last submittal of the opposing party, if any. ENGINEER's written decision on such Claim, dispute, or other matter will be final and binding upon OWNER and CONTRACTOR unless:

1. an appeal from ENGINEER's decision is taken within the time limits and in accordance with the dispute resolution procedures set forth in Article 16; or

2. if no such dispute resolution procedures have been set forth in Article 16, a written notice of intention to appeal from ENGINEER's written decision is delivered by OWNER or CONTRACTOR to the other and to ENGINEER within 30 days after the date of such decision, and a formal proceeding is instituted by the appealing party in a forum of competent jurisdiction within 60 days after the date of such decision or within 60 days after Substantial Completion, whichever is later (unless otherwise agreed in writing by OWNER and CONTRACTOR), to exercise such rights or remedies as the appealing party may have with respect to such Claim, dispute, or other matter in accordance with applicable Laws and Regulations.

C. If ENGINEER does not render a formal decision in writing within the time stated in paragraph 10.05.B, a decision denying the Claim in its entirety shall be deemed to have been issued 31 days after receipt of the last submittal of the claimant or the last submittal of the opposing party, if any.

D. No Claim for an adjustment in Contract Price or Contract Times (or Milestones) will be valid if not submitted in accordance with this paragraph 10.05.

---

ARTICLE 11 - COST OF THE WORK; CASH ALLOWANCES; UNIT PRICE WORK

---

11.01 *Cost of the Work*

A. *Costs Included:* The term Cost of the Work means the sum of all costs necessarily incurred and paid by CONTRACTOR in the proper performance of the Work. When the value of any Work covered by a Change Order or when a Claim for an adjustment in Contract Price is determined on the basis of Cost of the Work, the costs to be reimbursed to CONTRACTOR will be only those additional or incremental costs required because of the change in the Work or because of the event giving rise to the Claim. Except as otherwise may be agreed to in writing by OWNER, such costs shall be in amounts no higher than those prevailing in the locality of the Project, shall include only the following items, and shall not include any of the costs itemized in paragraph 11.01.B.

1. Payroll costs for employees in the direct employ of CONTRACTOR in the performance of the Work under schedules of job classifications agreed upon by OWNER and CONTRACTOR. Such employees shall include without limitation superintendents, foremen, and other personnel employed full time at the Site. Payroll costs for employees not employed full time on the Work shall be apportioned on the basis of their time spent on the Work. Payroll costs shall include, but not be limited to, salaries and wages plus the cost of fringe benefits, which shall include social security contributions, unemployment, excise, and payroll taxes, workers' compensation, health and retirement benefits, bonuses, sick leave, vacation and holiday pay applicable thereto. The expenses of performing Work outside of regular working hours, on Saturday, Sunday, or legal holidays, shall be included in the above to the extent authorized by OWNER.

2. Cost of all materials and equipment furnished and incorporated in the Work, including costs of transportation and storage thereof, and

Suppliers' field services required in connection therewith. All cash discounts shall accrue to CONTRACTOR unless OWNER deposits funds with CONTRACTOR with which to make payments, in which case the cash discounts shall accrue to OWNER. All trade discounts, rebates and refunds and returns from sale of surplus materials and equipment shall accrue to OWNER, and CONTRACTOR shall make provisions so that they may be obtained.

3. Payments made by CONTRACTOR to Subcontractors for Work performed by Subcontractors. If required by OWNER, CONTRACTOR shall obtain competitive bids from subcontractors acceptable to OWNER and CONTRACTOR and shall deliver such bids to OWNER, who will then determine, with the advice of ENGINEER, which bids, if any, will be acceptable. If any subcontract provides that the Subcontractor is to be paid on the basis of Cost of the Work plus a fee, the Subcontractor's Cost of the Work and fee shall be determined in the same manner as CONTRACTOR's Cost of the Work and fee as provided in this paragraph 11.01.

4. Costs of special consultants (including but not limited to engineers, architects, testing laboratories, surveyors, attorneys, and accountants) employed for services specifically related to the Work.

5. Supplemental costs including the following:

a. The proportion of necessary transportation, travel, and subsistence expenses of CONTRACTOR's employees incurred in discharge of duties connected with the Work.

b. Cost, including transportation and maintenance, of all materials, supplies, equipment, machinery, appliances, office, and temporary facilities at the Site, and hand tools not owned by the workers, which are consumed in the performance of the Work, and cost, less market value, of such items used but not consumed which remain the property of CONTRACTOR.

c. Rentals of all construction equipment and machinery, and the parts thereof whether rented from CONTRACTOR or others in accordance with rental agreements approved by OWNER with the advice of ENGINEER, and the costs of transportation, loading, unloading, assembly, dismantling, and removal thereof. All such costs shall be in accordance with the terms of said rental agreements. The rental of any such equipment,

---

machinery, or parts shall cease when the use thereof is no longer necessary for the Work.

d. Sales, consumer, use, and other similar taxes related to the Work, and for which CONTRACTOR is liable, imposed by Laws and Regulations.

e. Deposits lost for causes other than negligence of CONTRACTOR, any Subcontractor, or anyone directly or indirectly employed by any of them or for whose acts any of them may be liable, and royalty payments and fees for permits and licenses.

f. Losses and damages (and related expenses) caused by damage to the Work, not compensated by insurance or otherwise, sustained by CONTRACTOR in connection with the performance of the Work (except losses and damages within the deductible amounts of property insurance established in accordance with paragraph 5.06.D), provided such losses and damages have resulted from causes other than the negligence of CONTRACTOR, any Subcontractor, or anyone directly or indirectly employed by any of them or for whose acts any of them may be liable. Such losses shall include settlements made with the written consent and approval of OWNER. No such losses, damages, and expenses shall be included in the Cost of the Work for the purpose of determining CONTRACTOR's fee.

g. The cost of utilities, fuel, and sanitary facilities at the Site.

h. Minor expenses such as telegrams, long distance telephone calls, telephone service at the Site, expressage, and similar petty cash items in connection with the Work.

i. When the Cost of the Work is used to determine the value of a Change Order or of a Claim, the cost of premiums for additional Bonds and insurance required because of the changes in the Work or caused by the event giving rise to the Claim.

j. When all the Work is performed on the basis of cost-plus, the costs of premiums for all Bonds and insurance CONTRACTOR is required by the Contract Documents to purchase and maintain.

B. *Costs Excluded:* The term Cost of the Work shall not include any of the following items:

1. Payroll costs and other compensation of CONTRACTOR's officers, executives, principals

(of partnerships and sole proprietorships), general managers, engineers, architects, estimators, attorneys, auditors, accountants, purchasing and contracting agents, expeditors, timekeepers, clerks, and other personnel employed by CONTRACTOR, whether at the Site or in CONTRACTOR's principal or branch office for general administration of the Work and not specifically included in the agreed upon schedule of job classifications referred to in paragraph 11.01.A.1 or specifically covered by paragraph 11.01.A.4, all of which are to be considered administrative costs covered by the CONTRACTOR's fee.

2. Expenses of CONTRACTOR's principal and branch offices other than CONTRACTOR's office at the Site.

3. Any part of CONTRACTOR's capital expenses, including interest on CONTRACTOR's capital employed for the Work and charges against CONTRACTOR for delinquent payments.

4. Costs due to the negligence of CONTRACTOR, any Subcontractor, or anyone directly or indirectly employed by any of them or for whose acts any of them may be liable, including but not limited to, the correction of defective Work, disposal of materials or equipment wrongly supplied, and making good any damage to property.

5. Other overhead or general expense costs of any kind and the costs of any item not specifically and expressly included in paragraphs 11.01.A and 11.01.B.

C. *CONTRACTOR's Fee:* When all the Work is performed on the basis of cost-plus, CONTRACTOR's fee shall be determined as set forth in the Agreement. When the value of any Work covered by a Change Order or when a Claim for an adjustment in Contract Price is determined on the basis of Cost of the Work, CONTRACTOR's fee shall be determined as set forth in paragraph 12.01.C.

D. *Documentation:* Whenever the Cost of the Work for any purpose is to be determined pursuant to paragraphs 11.01.A and 11.01.B, CONTRACTOR will establish and maintain records thereof in accordance with generally accepted accounting practices and submit in a form acceptable to ENGINEER an itemized cost breakdown together with supporting data.

#### 11.02 *Cash Allowances*

A. It is understood that CONTRACTOR has included in the Contract Price all allowances so named in the Contract Documents and shall cause the Work so covered to be performed for such sums as may be acceptable to OWNER and ENGINEER. CONTRACTOR agrees that:

1. the allowances include the cost to CONTRACTOR (less any applicable trade discounts) of materials and equipment required by the allowances to be delivered at the Site, and all applicable taxes; and

2. CONTRACTOR's costs for unloading and handling on the Site, labor, installation costs, overhead, profit, and other expenses contemplated for the allowances have been included in the Contract Price and not in the allowances, and no demand for additional payment on account of any of the foregoing will be valid.

B. Prior to final payment, an appropriate Change Order will be issued as recommended by ENGINEER to reflect actual amounts due CONTRACTOR on account of Work covered by allowances, and the Contract Price shall be correspondingly adjusted.

#### 11.03 Unit Price Work

A. Where the Contract Documents provide that all or part of the Work is to be Unit Price Work, initially the Contract Price will be deemed to include for all Unit Price Work an amount equal to the sum of the unit price for each separately identified item of Unit Price Work times the estimated quantity of each item as indicated in the Agreement. The estimated quantities of items of Unit Price Work are not guaranteed and are solely for the purpose of comparison of Bids and determining an initial Contract Price. Determinations of the actual quantities and classifications of Unit Price Work performed by CONTRACTOR will be made by ENGINEER subject to the provisions of paragraph 9.08.

B. Each unit price will be deemed to include an amount considered by CONTRACTOR to be adequate to cover CONTRACTOR's overhead and profit for each separately identified item.

*SEE SUPPLEMENTARY CONDITIONS (SECTION 00800)*

~~C. OWNER or CONTRACTOR may make a Claim for an adjustment in the Contract Price in accordance with paragraph 10.05 if:~~

~~1. the quantity of any item of Unit Price Work performed by CONTRACTOR differs materially and significantly from the estimated quantity of such item indicated in the Agreement; and~~

~~2. there is no corresponding adjustment with respect any other item of Work; and~~

~~3. if CONTRACTOR believes that CONTRACTOR is entitled to an increase in Contract Price as a result of having incurred additional expense or OWNER believes that OWNER is entitled to a decrease in Contract Price and the parties are unable to agree as to the amount of any such increase or decrease.~~

## ARTICLE 12 - CHANGE OF CONTRACT PRICE; CHANGE OF CONTRACT TIMES

### 12.01 Change of Contract Price

A. The Contract Price may only be changed by a Change Order or by a Written Amendment. Any Claim for an adjustment in the Contract Price shall be based on written notice submitted by the party making the Claim to the ENGINEER and the other party to the Contract in accordance with the provisions of paragraph 10.05.

B. The value of any Work covered by a Change Order or of any Claim for an adjustment in the Contract Price will be determined as follows:

1. where the Work involved is covered by unit prices contained in the Contract Documents, by application of such unit prices to the quantities of the items involved (subject to the provisions of paragraph 11.03 ); or

2. where the Work involved is not covered by unit prices contained in the Contract Documents, by a mutually agreed lump sum (which may include an allowance for overhead and profit not necessarily in accordance with paragraph 12.01.C.2); or

3. where the Work involved is not covered by unit prices contained in the Contract Documents and agreement to a lump sum is not reached under paragraph 12.01.B.2, on the basis of the Cost of the Work (determined as provided in paragraph 11.01) plus a CONTRACTOR's fee for overhead and profit (determined as provided in paragraph 12.01.C).

C. *CONTRACTOR's Fee:* The CONTRACTOR's fee for overhead and profit shall be determined as follows:

1. a mutually acceptable fixed fee; or

2. if a fixed fee is not agreed upon, then a fee based on the following percentages of the various portions of the Cost of the Work:



---

a. for costs incurred under paragraphs 11.01.A.1 and 11.01.A.2, the CONTRACTOR's fee shall be 15 percent;

b. for costs incurred under paragraph 11.01.A.3, the CONTRACTOR's fee shall be five percent;

c. where one or more tiers of subcontracts are on the basis of Cost of the Work plus a fee and no fixed fee is agreed upon, the intent of paragraph 12.01.C.2.a is that the Subcontractor who actually performs the Work, at whatever tier, will be paid a fee of 15 percent of the costs incurred by such Subcontractor under paragraphs 11.01.A.1 and 11.01.A.2 and that any higher tier Subcontractor and CONTRACTOR will each be paid a fee of five percent of the amount paid to the next lower tier Subcontractor;

d. no fee shall be payable on the basis of costs itemized under paragraphs 11.01.A.4, 11.01.A.5, and 11.01.B;

e. the amount of credit to be allowed by CONTRACTOR to OWNER for any change which results in a net decrease in cost will be the amount of the actual net decrease in cost plus a deduction in CONTRACTOR's fee by an amount equal to five percent of such net decrease; and

f. when both additions and credits are involved in any one change, the adjustment in CONTRACTOR's fee shall be computed on the basis of the net change in accordance with paragraphs 12.01.C.2.a through 12.01.C.2.e, inclusive.

## 12.02 *Change of Contract Times*

A. The Contract Times (or Milestones) may only be changed by a Change Order or by a Written Amendment. Any Claim for an adjustment in the Contract Times (or Milestones) shall be based on written notice submitted by the party making the claim to the ENGINEER and the other party to the Contract in accordance with the provisions of paragraph 10.05.

B. Any adjustment of the Contract Times (or Milestones) covered by a Change Order or of any Claim for an adjustment in the Contract Times (or Milestones) will be determined in accordance with the provisions of this Article 12.

## 12.03 *Delays Beyond CONTRACTOR's Control*

A. Where CONTRACTOR is prevented from completing any part of the Work within the Contract Times (or Milestones) due to delay beyond the control of CONTRACTOR, the Contract Times (or Milestones) will be extended in an amount equal to the time lost due to such delay if a Claim is made therefore as provided in paragraph 12.02.A. Delays beyond the control of CONTRACTOR shall include, but not be limited to, acts or neglect by OWNER, acts or neglect of utility owners or other contractors performing other work as contemplated by Article 7, fires, floods, epidemics, abnormal weather conditions, or acts of God.

## 12.04 *Delays Within CONTRACTOR's Control*

A. The Contract Times (or Milestones) will not be extended due to delays within the control of CONTRACTOR. Delays attributable to and within the control of a Subcontractor or Supplier shall be deemed to be delays within the control of CONTRACTOR.

## 12.05 *Delays Beyond OWNER's and CONTRACTOR's Control*

A. Where CONTRACTOR is prevented from completing any part of the Work within the Contract Times (or Milestones) due to delay beyond the control of both OWNER and CONTRACTOR, an extension of the Contract Times (or Milestones) in an amount equal to the time lost due to such delay shall be CONTRACTOR's sole and exclusive remedy for such delay.

## 12.06 *Delay Damages*

A. In no event shall OWNER or ENGINEER be liable to CONTRACTOR, any Subcontractor, any Supplier, or any other person or organization, or to any surety for or employee or agent of any of them, for damages arising out of or resulting from:

1. delays caused by or within the control of CONTRACTOR; or

2. delays beyond the control of both OWNER and CONTRACTOR including but not limited to fires, floods, epidemics, abnormal weather conditions, acts of God, or acts or neglect by utility owners or other contractors performing other work as contemplated by Article 7.

B. Nothing in this paragraph 12.06 bars a change in Contract Price pursuant to this Article 12 to compensate CONTRACTOR due to delay, interference, or disruption directly attributable to actions or inactions of OWNER or anyone for whom OWNER is responsible.

---

ARTICLE 13 - TESTS AND INSPECTIONS;  
CORRECTION, REMOVAL OR ACCEPTANCE OF  
DEFECTIVE WORK

---

13.01 *Notice of Defects*

A. Prompt notice of all defective Work of which OWNER or ENGINEER has actual knowledge will be given to CONTRACTOR. All defective Work may be rejected, corrected, or accepted as provided in this Article 13.

13.02 *Access to Work*

A. OWNER, ENGINEER, ENGINEER's Consultants, other representatives and personnel of OWNER, independent testing laboratories, and governmental agencies with jurisdictional interests will have access to the Site and the Work at reasonable times for their observation, inspecting, and testing. CONTRACTOR shall provide them proper and safe conditions for such access and advise them of CONTRACTOR's Site safety procedures and programs so that they may comply therewith as applicable.

13.03 *Tests and Inspections*

*SEE SUPPLEMENTARY CONDITIONS (SECTION 00800)*

~~A. CONTRACTOR shall give ENGINEER timely notice of readiness of the Work for all required inspections, tests, or approvals and shall cooperate with inspection and testing personnel to facilitate required inspections or tests.~~

~~B. OWNER shall employ and pay for the services of an independent testing laboratory to perform all inspections, tests, or approvals required by the Contract Documents except:~~

~~1. for inspections, tests, or approvals covered by paragraphs 13.03.C and 13.03.D below;~~

~~2. that costs incurred in connection with tests or inspections conducted pursuant to paragraph 13.04.B shall be paid as provided in said paragraph 13.04.B; and~~

~~3. as otherwise specifically provided in the Contract Documents.~~

C. If Laws or Regulations of any public body having jurisdiction require any Work (or part thereof) specifically to be inspected, tested, or approved by an employee or other representative of such public body, CONTRACTOR shall assume full responsibility for arranging and obtaining such inspections, tests, or approvals, pay all costs in connection therewith, and furnish ENGINEER the required certificates of inspection or approval.

D. CONTRACTOR shall be responsible for arranging and obtaining and shall pay all costs in connection with any inspections, tests, or approvals required for OWNER's and ENGINEER's acceptance of materials or equipment to be incorporated in the Work; or acceptance of materials, mix designs, or equipment submitted for approval prior to CONTRACTOR's purchase thereof for incorporation in the Work. Such inspections, tests, or approvals shall be performed by organizations acceptable to OWNER and ENGINEER.

E. If any Work (or the work of others) that is to be inspected, tested, or approved is covered by CONTRACTOR without written concurrence of ENGINEER, it must, if requested by ENGINEER, be uncovered for observation.

F. Uncovering Work as provided in paragraph 13.03.E shall be at CONTRACTOR's expense unless CONTRACTOR has given ENGINEER timely notice of CONTRACTOR's intention to cover the same and ENGINEER has not acted with reasonable promptness in response to such notice.

13.04 *Uncovering Work*

A. If any Work is covered contrary to the written request of ENGINEER, it must, if requested by ENGINEER, be uncovered for ENGINEER's observation and replaced at CONTRACTOR's expense.

B. If ENGINEER considers it necessary or advisable that covered Work be observed by ENGINEER or inspected or tested by others, CONTRACTOR, at ENGINEER's request, shall uncover, expose, or otherwise make available for observation, inspection, or testing as ENGINEER may require, that portion of the Work in question, furnishing all necessary labor, material, and equipment. If it is found that such Work is defective, CONTRACTOR shall pay all Claims, costs, losses, and damages (including but not limited to all fees and charges of engineers, architects, attorneys, and other professionals and all court or arbitration or other dispute resolution costs) arising out of or relating to such uncovering, exposure, observation, inspection, and testing, and of satisfactory replacement or reconstruction (including but not limited to all costs of repair or replacement of work of others); and OWNER shall be entitled to an appropriate decrease in the Contract Price. If the parties are unable to agree as to the amount thereof, OWNER may make a Claim therefor as provided in paragraph 10.05. If, however, such Work is not found to be defective, CONTRACTOR shall be allowed an increase in the Contract Price or an extension of the Contract Times (or Milestones), or both, directly attributable to such uncovering, exposure, observation, inspection, testing, replacement, and reconstruction. If the parties are unable to agree as to the amount or extent thereof,

---

CONTRACTOR may make a Claim therefore as provided in paragraph 10.05.

#### 13.05 *OWNER May Stop the Work*

A. If the Work is defective, or CONTRACTOR fails to supply sufficient skilled workers or suitable materials or equipment, or fails to perform the Work in such a way that the completed Work will conform to the Contract Documents, OWNER may order CONTRACTOR to stop the Work, or any portion thereof, until the cause for such order has been eliminated; however, this right of OWNER to stop the Work shall not give rise to any duty on the part of OWNER to exercise this right for the benefit of CONTRACTOR, any Subcontractor, any Supplier, any other individual or entity, or any surety for, or employee or agent of any of them.

#### 13.06 *Correction or Removal of Defective Work*

A. CONTRACTOR shall correct all defective Work, whether or not fabricated, installed, or completed, or, if the Work has been rejected by ENGINEER, remove it from the Project and replace it with Work that is not defective. CONTRACTOR shall pay all Claims, costs, losses, and damages (including but not limited to all fees and charges of engineers, architects, attorneys, and other professionals and all court or arbitration or other dispute resolution costs) arising out of or relating to such correction or removal (including but not limited to all costs of repair or replacement of work of others).

#### 13.07 *Correction Period*

A. If within one year after the date of Substantial Completion or such longer period of time as may be prescribed by Laws or Regulations or by the terms of any applicable special guarantee required by the Contract Documents or by any specific provision of the Contract Documents, any Work is found to be defective, or if the repair of any damages to the land or areas made available for CONTRACTOR's use by OWNER or permitted by Laws and Regulations as contemplated in paragraph 6.11.A is found to be defective, CONTRACTOR shall promptly, without cost to OWNER and in accordance with OWNER's written instructions: (i) repair such defective land or areas, or (ii) correct such defective Work or, if the defective Work has been rejected by OWNER, remove it from the Project and replace it with Work that is not defective, and (iii) satisfactorily correct or repair or remove and replace any damage to other Work, to the work of others or other land or areas resulting there from. If CONTRACTOR does not promptly comply with the terms of such instructions, or in an emergency where delay would cause serious risk of loss or damage, OWNER may have the defective Work corrected or repaired or may have the rejected Work removed and replaced, and all Claims, costs, losses, and damages (including but not limited to all fees

and charges of engineers, architects, attorneys, and other professionals and all court or arbitration or other dispute resolution costs) arising out of or relating to such correction or repair or such removal and replacement (including but not limited to all costs of repair or replacement of work of others) will be paid by CONTRACTOR.

B. In special circumstances where a particular item of equipment is placed in continuous service before Substantial Completion of all the Work, the correction period for that item may start to run from an earlier date if so provided in the Specifications or by Written Amendment.

C. Where defective Work (and damage to other Work resulting there from) has been corrected or removed and replaced under this paragraph 13.07, the correction period hereunder with respect to such Work will be extended for an additional period of one year after such correction or removal and replacement has been satisfactorily completed.

D. CONTRACTOR's obligations under this paragraph 13.07 are in addition to any other obligation or warranty. The provisions of this paragraph 13.07 shall not be construed as a substitute for or a waiver of the provisions of any applicable statute of limitation or repose.

#### 13.08 *Acceptance of Defective Work*

A. If, instead of requiring correction or removal and replacement of defective Work, OWNER (and, prior to ENGINEER's recommendation of final payment, ENGINEER) prefers to accept it, OWNER may do so. CONTRACTOR shall pay all Claims, costs, losses, and damages (including but not limited to all fees and charges of engineers, architects, attorneys, and other professionals and all court or arbitration or other dispute resolution costs) attributable to OWNER's evaluation of and determination to accept such defective Work (such costs to be approved by ENGINEER as to reasonableness) and the diminished value of the Work to the extent not otherwise paid by CONTRACTOR pursuant to this sentence. If any such acceptance occurs prior to ENGINEER's recommendation of final payment, a Change Order will be issued incorporating the necessary revisions in the Contract Documents with respect to the Work, and OWNER shall be entitled to an appropriate decrease in the Contract Price, reflecting the diminished value of Work so accepted. If the parties are unable to agree as to the amount thereof, OWNER may make a Claim therefore as provided in paragraph 10.05. If the acceptance occurs after such recommendation, an appropriate amount will be paid by CONTRACTOR to OWNER.

#### 13.09 *OWNER May Correct Defective Work*

---

A. If CONTRACTOR fails within a reasonable time after written notice from ENGINEER to correct defective Work or to remove and replace rejected Work as required by ENGINEER in accordance with paragraph 13.06.A, or if CONTRACTOR fails to perform the Work in accordance with the Contract Documents, or if CONTRACTOR fails to comply with any other provision of the Contract Documents, OWNER may, after seven days written notice to CONTRACTOR, correct and remedy any such deficiency.

B. In exercising the rights and remedies under this paragraph, OWNER shall proceed expeditiously. In connection with such corrective and remedial action, OWNER may exclude CONTRACTOR from all or part of the Site, take possession of all or part of the Work and suspend CONTRACTOR's services related thereto, take possession of CONTRACTOR's tools, appliances, construction equipment and machinery at the Site, and incorporate in the Work all materials and equipment stored at the Site or for which OWNER has paid CONTRACTOR but which are stored elsewhere. CONTRACTOR shall allow OWNER, OWNER's representatives, agents and employees, OWNER's other contractors, and ENGINEER and ENGINEER's Consultants access to the Site to enable OWNER to exercise the rights and remedies under this paragraph.

C. All Claims, costs, losses, and damages (including but not limited to all fees and charges of engineers, architects, attorneys, and other professionals and all court or arbitration or other dispute resolution costs) incurred or sustained by OWNER in exercising the rights and remedies under this paragraph 13.09 will be charged against CONTRACTOR, and a Change Order will be issued incorporating the necessary revisions in the Contract Documents with respect to the Work; and OWNER shall be entitled to an appropriate decrease in the Contract Price. If the parties are unable to agree as to the amount of the adjustment, OWNER may make a Claim therefore as provided in paragraph 10.05. Such claims, costs, losses and damages will include but not be limited to all costs of repair, or replacement of work of others destroyed or damaged by correction, removal, or replacement of CONTRACTOR's defective Work.

D. CONTRACTOR shall not be allowed an extension of the Contract Times (or Milestones) because of any delay in the performance of the Work attributable to the exercise by OWNER of OWNER's rights and remedies under this paragraph 13.09.

---

## ARTICLE 14 - PAYMENTS TO CONTRACTOR AND COMPLETION

---

### 14.01 *Schedule of Values*

A. The schedule of values established as provided in paragraph 2.07.A will serve as the basis for progress payments and will be incorporated into a form of Application for Payment acceptable to ENGINEER. Progress payments on account of Unit Price Work will be based on the number of units completed.

### 14.02 *Progress Payments*

#### A. *Applications for Payments*

1. At least 20 days before the date established for each progress payment (but not more often than once a month), CONTRACTOR shall submit to ENGINEER for review an Application for Payment filled out and signed by CONTRACTOR covering the Work completed as of the date of the Application and accompanied by such supporting documentation as is required by the Contract Documents. If payment is requested on the basis of materials and equipment not incorporated in the Work but delivered and suitably stored at the Site or at another location agreed to in writing, the Application for Payment shall also be accompanied by a bill of sale, invoice, or other documentation warranting that OWNER has received the materials and equipment free and clear of all Liens and evidence that the materials and equipment are covered by appropriate property insurance or other arrangements to protect OWNER's interest therein, all of which must be satisfactory to OWNER.

2. Beginning with the second Application for Payment, each Application shall include an affidavit of CONTRACTOR stating that all previous progress payments received on account of the Work have been applied on account to discharge CONTRACTOR's legitimate obligations associated with prior Applications for Payment.

3. The amount of retainage with respect to pro-gress payments will be as stipulated in the Agreement.

#### B. *Review of Applications*

1. ENGINEER will, within 10 days after receipt of each Application for Payment, either indicate in writing a recommendation of payment and present the Application to OWNER or return the Application to CONTRACTOR indicating in writing ENGINEER's reasons for refusing to

---

recommend payment. In the latter case, CONTRACTOR may make the necessary corrections and resubmit the Application.

2. ENGINEER's recommendation of any payment requested in an Application for Payment will constitute a representation by ENGINEER to OWNER, based on ENGINEER's observations on the Site of the executed Work as an experienced and qualified design professional and on ENGINEER's review of the Application for Payment and the accompanying data and schedules, that to the best of ENGINEER's knowledge, information and belief:

a. the Work has progressed to the point indicated;

b. the quality of the Work is generally in accordance with the Contract Documents (subject to an evaluation of the Work as a functioning whole prior to or upon Substantial Completion, to the results of any subsequent tests called for in the Contract Documents, to a final determination of quantities and classifications for Unit Price Work under paragraph 9.08, and to any other qualifications stated in the recommendation); and

c. the conditions precedent to CONTRACTOR's being entitled to such payment appear to have been fulfilled in so far as it is ENGINEER's responsibility to observe the Work.

3. By recommending any such payment ENGINEER will not thereby be deemed to have represented that: (i) inspections made to check the quality or the quantity of the Work as it has been performed have been exhaustive, extended to every aspect of the Work in progress, or involved detailed inspections of the Work beyond the responsibilities specifically assigned to ENGINEER in the Contract Documents; or (ii) that there may not be other matters or issues between the parties that might entitle CONTRACTOR to be paid additionally by OWNER or entitle OWNER to withhold payment to CONTRACTOR.

4. Neither ENGINEER's review of CONTRACTOR's Work for the purposes of recommending payments nor ENGINEER's recommendation of any payment, including final payment, will impose responsibility on ENGINEER to supervise, direct, or control the Work or for the means, methods, techniques, sequences, or procedures of construction, or the safety precautions and programs incident thereto, or for CONTRACTOR's failure to comply with Laws and

Regulations applicable to CONTRACTOR's performance of the Work. Additionally, said review or recommendation will not impose responsibility on ENGINEER to make any examination to ascertain how or for what purposes CONTRACTOR has used the moneys paid on account of the Contract Price, or to determine that title to any of the Work, materials, or equipment has passed to OWNER free and clear of any Liens.

*SEE ALSO SUPPLEMENTARY CONDITIONS (SECTION 00800)*

5. ENGINEER may refuse to recommend the whole or any part of any payment if, in ENGINEER's opinion, it would be incorrect to make the representations to OWNER referred to in paragraph 14.02.B.2. ENGINEER may also refuse to recommend any such payment or, because of subsequently discovered evidence or the results of subsequent inspections or tests, revise or revoke any such payment recommendation previously made, to such extent as may be necessary in ENGINEER's opinion to protect OWNER from loss because:

a. the Work is defective, or completed Work has been damaged, requiring correction or replacement;

b. the Contract Price has been reduced by Written Amendment or Change Orders;

c. OWNER has been required to correct defective Work or complete Work in accordance with paragraph 13.09; or

d. ENGINEER has actual knowledge of the occurrence of any of the events enumerated in paragraph 15.02.A.

#### *C. Payment Becomes Due*

1. Ten days after presentation of the Application for Payment to OWNER with ENGINEER's recommendation, the amount recommended will (subject to the provisions of paragraph 14.02.D) become due, and when due will be paid by OWNER to CONTRACTOR.

#### *D. Reduction in Payment*

1. OWNER may refuse to make payment of the full amount recommended by ENGINEER because:

a. claims have been made against OWNER on account of CONTRACTOR's performance or furnishing of the Work;

b. Liens have been filed in connection with the Work, except where CONTRACTOR has delivered a specific Bond satisfactory to OWNER to secure the satisfaction and discharge of such Liens;

c. there are other items entitling OWNER to a set off against the amount recommended; or

d. OWNER has actual knowledge of the occurrence of any of the events enumerated in paragraphs 14.02.B.5.a through 14.02.B.5.c or paragraph 15.02.A.

2. If OWNER refuses to make payment of the full amount recommended by ENGINEER, OWNER must give CONTRACTOR immediate written notice (with a copy to ENGINEER) stating the reasons for such action and promptly pay CONTRACTOR any amount remaining after deduction of the amount so withheld. OWNER shall promptly pay CONTRACTOR the amount so withheld, or any adjustment thereto agreed to by OWNER and CONTRACTOR, when CONTRACTOR corrects to OWNER's satisfaction the reasons for such action.

3. If it is subsequently determined that OWNER's refusal of payment was not justified, the amount wrongfully withheld shall be treated as an amount due as determined by paragraph 14.02.C.1.

#### 14.03 *CONTRACTOR's Warranty of Title*

A. CONTRACTOR warrants and guarantees that title to all Work, materials, and equipment covered by any Application for Payment, whether incorporated in the Project or not, will pass to OWNER no later than the time of payment free and clear of all Liens.

#### 14.04 *Substantial Completion*

A. When CONTRACTOR considers the entire Work ready for its intended use CONTRACTOR shall notify OWNER and ENGINEER in writing that the entire Work is substantially complete (except for items specifically listed by CONTRACTOR as incomplete) and request that ENGINEER issue a certificate of Substantial Completion. Promptly thereafter, OWNER, CONTRACTOR, and ENGINEER shall make an inspection of the Work to determine the status of completion. If ENGINEER does not consider the Work substantially complete, ENGINEER will notify CONTRACTOR in writing giving the reasons therefore. If ENGINEER considers the Work substantially complete, ENGINEER will prepare and deliver to OWNER a tentative certificate of Substantial Completion which shall fix the date of Substantial Completion. There shall be

attached to the certificate a tentative list of items to be completed or corrected before final payment. OWNER shall have seven days after receipt of the tentative certificate during which to make written objection to ENGINEER as to any provisions of the certificate or attached list. If, after considering such objections, ENGINEER concludes that the Work is not substantially complete, ENGINEER will within 14 days after submission of the tentative certificate to OWNER notify CONTRACTOR in writing, stating the reasons therefore. If, after consideration of OWNER's objections, ENGINEER considers the Work substantially complete, ENGINEER will within said 14 days execute and deliver to OWNER and CONTRACTOR a definitive certificate of Substantial Completion (with a revised tentative list of items to be completed or corrected) reflecting such changes from the tentative certificate as ENGINEER believes justified after consideration of any objections from OWNER. At the time of delivery of the tentative certificate of Substantial Completion ENGINEER will deliver to OWNER and CONTRACTOR a written recommendation as to division of responsibilities pending final payment between OWNER and CONTRACTOR with respect to security, operation, safety, and protection of the Work, maintenance, heat, utilities, insurance, and warranties and guarantees. Unless OWNER and CONTRACTOR agree otherwise in writing and so inform ENGINEER in writing prior to ENGINEER's issuing the definitive certificate of Substantial Completion, ENGINEER's aforesaid recommendation will be binding on OWNER and CONTRACTOR until final payment.

B. OWNER shall have the right to exclude CONTRACTOR from the Site after the date of Substantial Completion, but OWNER shall allow CONTRACTOR reasonable access to complete or correct items on the tentative list.

#### 14.05 *Partial Utilization*

A. Use by OWNER at OWNER's option of any substantially completed part of the Work which has specifically been identified in the Contract Documents, or which OWNER, ENGINEER, and CONTRACTOR agree constitutes a separately functioning and usable part of the Work that can be used by OWNER for its intended purpose without significant interference with CONTRACTOR's performance of the remainder of the Work, may be accomplished prior to Substantial Completion of all the Work subject to the following conditions.

1. OWNER at any time may request CONTRACTOR in writing to permit OWNER to use any such part of the Work which OWNER believes to be ready for its intended use and substantially complete. If CONTRACTOR agrees that such part of the Work is substantially complete, CONTRACTOR will certify to OWNER and

---

ENGINEER that such part of the Work is substantially complete and request ENGINEER to issue a certificate of Substantial Completion for that part of the Work. CONTRACTOR at any time may notify OWNER and ENGINEER in writing that CONTRACTOR considers any such part of the Work ready for its intended use and substantially complete and request ENGINEER to issue a certificate of Substantial Completion for that part of the Work. Within a reasonable time after either such request, OWNER, CONTRACTOR, and ENGINEER shall make an inspection of that part of the Work to determine its status of completion. If ENGINEER does not consider that part of the Work to be substantially complete, ENGINEER will notify OWNER and CONTRACTOR in writing giving the reasons therefore. If ENGINEER considers that part of the Work to be substantially complete, the provisions of paragraph 14.04 will apply with respect to certification of Substantial Completion of that part of the Work and the division of responsibility in respect thereof and access thereto.

*SEE SUPPLEMENTARY CONDITIONS (SECTION 00800)*

~~2. No occupancy or separate operation of part of the Work may occur prior to compliance with the requirements of paragraph 5.10 regarding property insurance.~~

#### 14.06 Final Inspection

A. Upon written notice from CONTRACTOR that the entire Work or an agreed portion thereof is complete, ENGINEER will promptly make a final inspection with OWNER and CONTRACTOR and will notify CONTRACTOR in writing of all particulars in which this inspection reveals that the Work is incomplete or defective. CONTRACTOR shall immediately take such measures as are necessary to complete such Work or remedy such deficiencies.

#### 14.07 Final Payment

##### A. Application for Payment

1. After CONTRACTOR has, in the opinion of ENGINEER, satisfactorily completed all corrections identified during the final inspection and has delivered, in accordance with the Contract Documents, all maintenance and operating instructions, schedules, guarantees, Bonds, certificates or other evidence of insurance certificates of inspection, marked-up record documents (as provided in paragraph 6.12), and other documents, CONTRACTOR may make

application for final payment following the procedure for progress payments.

2. The final Application for Payment shall be accompanied (except as previously delivered) by: (i) all documentation called for in the Contract Documents, including but not limited to the evidence of insurance required by subparagraph 5.04.B.7; (ii) consent of the surety, if any, to final payment; and (iii) complete and legally effective releases or waivers (satisfactory to OWNER) of all Lien rights arising out of or Liens filed in connection with the Work.

3. In lieu of the releases or waivers of Liens specified in paragraph 14.07.A.2 and as approved by OWNER, CONTRACTOR may furnish receipts or releases in full and an affidavit of CONTRACTOR that: (i) the releases and receipts include all labor, services, material, and equipment for which a Lien could be filed; and (ii) all payrolls, material and equipment bills, and other indebtedness connected with the Work for which OWNER or OWNER's property might in any way be responsible have been paid or otherwise satisfied. If any Subcontractor or Supplier fails to furnish such a release or receipt in full, CONTRACTOR may furnish a Bond or other collateral satisfactory to OWNER to indemnify OWNER against any Lien.

##### B. Review of Application and Acceptance

1. If, on the basis of ENGINEER's observation of the Work during construction and final inspection, and ENGINEER's review of the final Application for Payment and accompanying documentation as required by the Contract Documents, ENGINEER is satisfied that the Work has been completed and CONTRACTOR's other obligations under the Contract Documents have been fulfilled, ENGINEER will, within ten days after receipt of the final Application for Payment, indicate in writing ENGINEER's recommendation of payment and present the Application for Payment to OWNER for payment. At the same time ENGINEER will also give written notice to OWNER and CONTRACTOR that the Work is acceptable subject to the provisions of paragraph 14.09. Otherwise, ENGINEER will return the Application for Payment to CONTRACTOR, indicating in writing the reasons for refusing to recommend final payment, in which case CONTRACTOR shall make the necessary corrections and resubmit the Application for Payment.

---

C. *Payment Becomes Due*

1. Thirty days after the presentation to OWNER of the Application for Payment and accompanying documentation, the amount recommended by ENGINEER will become due and, when due, will be paid by OWNER to CONTRACTOR.

14.08 *Final Completion Delayed*

A. If, through no fault of CONTRACTOR, final completion of the Work is significantly delayed, and if ENGINEER so confirms, OWNER shall, upon receipt of CONTRACTOR's final Application for Payment and recommendation of ENGINEER, and without terminating the Agreement, make payment of the balance due for that portion of the Work fully completed and accepted. If the remaining balance to be held by OWNER for Work not fully completed or corrected is less than the retainage stipulated in the Agreement, and if Bonds have been furnished as required in paragraph 5.01, the written consent of the surety to the payment of the balance due for that portion of the Work fully completed and accepted shall be submitted by CONTRACTOR to ENGINEER with the Application for such payment. Such payment shall be made under the terms and conditions governing final payment, except that it shall not constitute a waiver of Claims.

14.09 *Waiver of Claims*

A. The making and acceptance of final payment will constitute:

1. a waiver of all Claims by OWNER against CONTRACTOR, except Claims arising from unsettled Liens, from defective Work appearing after final inspection pursuant to paragraph 14.06, from failure to comply with the Contract Documents or the terms of any special guarantees specified therein, or from CONTRACTOR's continuing obligations under the Contract Documents; and

2. a waiver of all Claims by CONTRACTOR against OWNER other than those previously made in writing which are still unsettled.

ARTICLE 15 - SUSPENSION OF WORK AND TERMINATION

---

15.01 *OWNER May Suspend Work*

A. At any time and without cause, OWNER may suspend the Work or any portion thereof for a period of not

more than 90 consecutive days by notice in writing to CONTRACTOR and ENGINEER which will fix the date on which Work will be resumed. CONTRACTOR shall resume the Work on the date so fixed. CONTRACTOR shall be allowed an adjustment in the Contract Price or an extension of the Contract Times, or both, directly attributable to any such suspension if CONTRACTOR makes a Claim therefor as provided in paragraph 10.05.

15.02 *OWNER May Terminate for Cause*

A. The occurrence of any one or more of the following events will justify termination for cause:

1. CONTRACTOR's persistent failure to perform the Work in accordance with the Contract Documents (including, but not limited to, failure to supply sufficient skilled workers or suitable materials or equipment or failure to adhere to the progress schedule established under paragraph 2.07 as adjusted from time to time pursuant to paragraph 6.04);

2. CONTRACTOR's disregard of Laws or Regulations of any public body having jurisdiction;

3. CONTRACTOR's disregard of the authority of ENGINEER; or

4. CONTRACTOR's violation in any substantial way of any provisions of the Contract Documents.

B. If one or more of the events identified in paragraph 15.02.A occur, OWNER may, after giving CONTRACTOR (and the surety, if any) seven days written notice, terminate the services of CONTRACTOR, exclude CONTRACTOR from the Site, and take possession of the Work and of all CONTRACTOR's tools, appliances, construction equipment, and machinery at the Site, and use the same to the full extent they could be used by CONTRACTOR (without liability to CONTRACTOR for trespass or conversion), incorporate in the Work all materials and equipment stored at the Site or for which OWNER has paid CONTRACTOR but which are stored elsewhere, and finish the Work as OWNER may deem expedient. In such case, CONTRACTOR shall not be entitled to receive any further payment until the Work is finished. If the unpaid balance of the Contract Price exceeds all claims, costs, losses, and damages (including but not limited to all fees and charges of engineers, architects, attorneys, and other professionals and all court or arbitration or other dispute resolution costs) sustained by OWNER arising out of or relating to completing the Work, such excess will be paid to CONTRACTOR. If such claims, costs, losses, and damages exceed such unpaid balance, CONTRACTOR shall pay the difference to OWNER. Such claims, costs, losses, and damages incurred



by OWNER will be reviewed by ENGINEER as to their reasonableness and, when so approved by ENGINEER, incorporated in a Change Order. When exercising any rights or remedies under this paragraph OWNER shall not be required to obtain the lowest price for the Work performed.

C. Where CONTRACTOR's services have been so terminated by OWNER, the termination will not affect any rights or remedies of OWNER against CONTRACTOR then existing or which may thereafter accrue. Any retention or payment of moneys due CONTRACTOR by OWNER will not release CONTRACTOR from liability.

#### 15.03 *OWNER May Terminate For Convenience*

A. Upon seven days written notice to CONTRACTOR and ENGINEER, OWNER may, without cause and without prejudice to any other right or remedy of OWNER, elect to terminate the Contract. In such case, CONTRACTOR shall be paid (without duplication of any items):

1. for completed and acceptable Work executed in accordance with the Contract Documents prior to the effective date of termination, including fair and reasonable sums for overhead and profit on such Work;

2. for expenses sustained prior to the effective date of termination in performing services and furnishing labor, materials, or equipment as required by the Contract Documents in connection with uncompleted Work, plus fair and reasonable sums for overhead and profit on such expenses;

3. for all claims, costs, losses, and damages (including but not limited to all fees and charges of engineers, architects, attorneys, and other professionals and all court or arbitration or other dispute resolution costs) incurred in settlement of terminated contracts with Subcontractors, Suppliers, and others; and

4. for reasonable expenses directly attributable to termination.

B. CONTRACTOR shall not be paid on account of loss of anticipated profits or revenue or other economic loss arising out of or resulting from such termination.

#### 15.04 *CONTRACTOR May Stop Work or Terminate*

A. If, through no act or fault of CONTRACTOR, the Work is suspended for more than 90 consecutive days by OWNER or under an order of court or other public authority, or ENGINEER fails to act on any Application for Payment within 30 days after it is submitted, or OWNER

fails for 30 days to pay CONTRACTOR any sum finally determined to be due, then CONTRACTOR may, upon seven days written notice to OWNER and ENGINEER, and provided OWNER or ENGINEER do not remedy such suspension or failure within that time, terminate the Contract and recover from OWNER payment on the same terms as provided in paragraph 15.03. In lieu of terminating the Contract and without prejudice to any other right or remedy, if ENGINEER has failed to act on an Application for Payment within 30 days after it is submitted, or OWNER has failed for 30 days to pay CONTRACTOR any sum finally determined to be due, CONTRACTOR may, seven days after written notice to OWNER and ENGINEER, stop the Work until payment is made of all such amounts due CONTRACTOR, including interest thereon. The provisions of this paragraph 15.04 are not intended to preclude CONTRACTOR from making a Claim under paragraph 10.05 for an adjustment in Contract Price or Contract Times or otherwise for expenses or damage directly attributable to CONTRACTOR's stopping the Work as permitted by this paragraph.

## ARTICLE 16 - DISPUTE RESOLUTION

---

### 16.01 *Methods and Procedures*

A. Dispute resolution methods and procedures, if any, shall be as set forth in the Supplementary Conditions. If no method and procedure has been set forth, and subject to the provisions of paragraphs 9.09 and 10.05, OWNER and CONTRACTOR may exercise such rights or remedies as either may otherwise have under the Contract Documents or by Laws or Regulations in respect of any dispute.

## ARTICLE 17 - MISCELLANEOUS

---

### 17.01 *Giving Notice*

A. Whenever any provision of the Contract Documents requires the giving of written notice, it will be deemed to have been validly given if delivered in person to the individual or to a member of the firm or to an officer of the corporation for whom it is intended, or if delivered at or sent by registered or certified mail, postage prepaid, to the last business address known to the giver of the notice.

### 17.02 *Computation of Times*

A. When any period of time is referred to in the Contract Documents by days, it will be computed to exclude the first and include the last day of such period. If the last day of any such period falls on a Saturday or Sunday or on a day made a legal holiday by the law of the

---

applicable jurisdiction, such day will be omitted from the computation.

#### 17.03 *Cumulative Remedies*

A. The duties and obligations imposed by these General Conditions and the rights and remedies available hereunder to the parties hereto are in addition to, and are not to be construed in any way as a limitation of, any rights and remedies available to any or all of them which are otherwise imposed or available by Laws or Regulations, by special warranty or guarantee, or by other provisions of the Contract Documents, and the provisions of this paragraph will be as effective as if repeated specifically in the Contract Documents in connection with each particular duty, obligation, right, and remedy to which they apply.

#### 17.04 *Survival of Obligations*

A. All representations, indemnifications, warranties, and guarantees made in, required by, or given in accordance with the Contract Documents, as well as all continuing obligations indicated in the Contract Documents, will survive final payment, completion, and acceptance of the Work or termination or completion of the Agreement.

#### 17.05 *Controlling Law*

A. This Contract is to be governed by the law of the state in which the Project is located.

## SECTION 00800

### SUPPLEMENTARY CONDITIONS

These Supplementary Conditions amend or supplement the Standard General Conditions of the Construction Contract (No. 1910-8, 1996 ed.) and other provisions of the Contract Documents as indicated below. All provisions which are not so amended or supplemented remain in full force and effect.

The terms used in these Supplementary Conditions have the meanings assigned to them in the General Conditions. Additional terms used in these Supplementary Conditions have the meanings indicated below, which are applicable to both the singular and plural thereof.

**SC-2.02** OWNER shall furnish to CONTRACTOR up to four (4) copies of the Contract Documents as are reasonably necessary for the execution of the Work. Additional copies will be furnished, upon request, at the cost of reproduction.

**SC-2.04** CONTRACTOR shall start to perform the Work on the date when the Contract Time commences to run, but no Work shall be done by CONTRACTOR at the Site prior to the Effective Date of the Agreement.

**SC-2.05.C** The CONTRACTOR shall furnish the ENGINEER with five (5) copies of Certificates of Insurance on all required policies of insurance showing limits of liability as specified. All policies must provide thirty (30) days advance notice to the OWNER and ENGINEER in the event of cancellation, expiration or alteration. Each certificate shall be accompanied by a notarized statement itemizing each and every exclusion of the policy. All certificates shall be submitted with the Agreement for execution.

**SC-2.06** Within twenty (20) days after the Effective Date of the Agreement, a conference attended by CONTRACTOR, ENGINEER and others as appropriate may be held to establish a working understanding among the parties as to the work and to discuss the schedules referred to in paragraph 2.05.B of the General Conditions, procedures for handling Shop Drawings and other submittals, processing Applications for Payment, and maintaining required records.

**SC-2.07** If requested by the OWNER or ENGINEER, at least ten (10) days before submission of the first Application for Payment a conference attended by CONTRACTOR, ENGINEER and others as appropriate will be held to review for acceptability to ENGINEER as provided below the schedules submitted in accordance with paragraph 2.05.B of the General Conditions. CONTRACTOR shall have an additional ten (10) days to make corrections and adjustments and to complete and resubmit the schedules. No progress payment shall be made to CONTRACTOR until the schedules are submitted to and acceptable to ENGINEER as provided below. The progress schedule will be acceptable to ENGINEER as providing an orderly progression of the Work to completion within any specified Milestones and the Contract Times, but such acceptance will neither impose on ENGINEER responsibility for the sequencing, scheduling or progress of the Work nor interfere with or relieve CONTRACTOR from CONTRACTOR's full responsibility therefor. CONTRACTOR's schedule of Shop Drawing and Sample submissions will be acceptable to ENGINEER as providing a workable arrangement for reviewing and processing the required submittals.

Contractors schedule of values will be acceptable to Engineer as to form and substance if it provides a reasonable allocation of the Contract Price to component parts of the Work.

**SC-3.01** In the event of a conflict between the various items which make up the Contract Documents, the following Hierarchy of Documents shall prevail:

1. Contract Change Orders
2. Addenda
3. Special Conditions
4. Agreement
- .
5. Supplementary Conditions
6. General Conditions
7. Technical Specifications
8. Drawings.

**SC-4.02** Reports of subsurface explorations and tests at the project Site are included in Section 00200 of the Bidding Documents. The CONTRACTOR may rely upon the accuracy of the Technical Data contained in such reports as per paragraphs 4.02.B of the General Conditions. Information included in such reports which may be considered Technical Data are: The Boring Method, Plan and Logs, Level of Subsurface Water, Laboratory Test Methods and Results and Similar Factual Data, all as of the dates made. These reports are not part of the Contract Documents, but the Technical Data contained therein upon which the CONTRACTOR is entitled to rely as provided in G.C. 4.02 as identified above are incorporated therein by reference.

**SC-4.03, 4.04** The plans show certain features of the topography and certain underground utilities, but they do not purport to show in detail all such lines or obstructions. Such topography and notes on the plans were inserted from records available and are for the CONTRACTOR's convenience only, and shall not be used as basis for any claims of extra compensation.

All pipes or other underground utilities shall be maintained in continuous service where possible and shall be properly protected and supported. In no case shall interruptions to utilities be allowed to exist outside of working hours.

Prior to starting the work, the proper authorities of all utilities shall be notified by the Contractor and the Contractor shall cooperate in every way possible with these authorities. Whenever necessary to determine the location of existing pipes, valves or other underground structures, the CONTRACTOR shall examine all available records and shall make all explorations and excavations necessary for such purpose.

**SC-5.01** Add the following new paragraph immediately after paragraph 5.01.C of the General Conditions:

- D.** Prior to commencing work, payment and performance bonds required by this contract shall be filed in the public records of the county where said is performed pursuant to the requirements of Section 255.05, Florida Statutes.

**SC-5.04** Add the following new paragraph immediately after paragraph 5.04.B of the General Conditions:

**C.** The limits of liability for the insurance required by paragraph 5.04 of the General Conditions shall provide coverage for not less than the following amounts or greater where required by Laws and Regulations:

**1.** Workers' Compensation and related coverages under paragraphs 5.04.A.1 and 5.04.A.2 of the General Conditions:

- |   |                    |
|---|--------------------|
| a.) State:                                    | Statutory          |
| b.) Applicable Federal (e.g. Longshoreman's): | Statutory          |
| c.) Employer's Liability                      | <u>\$1,000,000</u> |

**2. CONTRACTOR's Liability Insurance** under paragraphs 5.04.A.3 through A.6 of the General Conditions which shall also include completed operations and product liability coverages and eliminate the exclusion with respect to property under the care custody and control of the CONTRACTOR:

- |   |                    |
|---|--------------------|
| a.) General Aggregate<br>(Except Products - Completed Operations)   | <u>\$2,000,000</u> |
| b.) Products - Completed Operations Aggregate   | <u>\$2,000,000</u> |
| c.) Personal and Advertising<br>Injury (Per Person/Organization)  | <u>\$1,000,000</u> |
| d.) Each Occurrence<br>(Bodily Injury and Property Damage)  | <u>\$1,000,000</u> |
| e.) Property Damage Liability Insurance will provide Explosion,<br>Collapse and Underground coverages where applicable. |                    |
| f.) Excess Liability<br>General Aggregate   | <u>\$2,000,000</u> |
| Each Occurrence   | <u>\$2,000,000</u> |

**3. Automobile Liability:**

- |                      |  |
|----------------------|--|
| a.) Bodily Injury:   | <u>\$1,000,000</u> Each Person<br><u>\$1,000,000</u> Each Accident |
| b.) Property Damage: | <u>\$500,000</u> Each Accident                                     |

OR

- |   |                                  |
|---|----------------------------------|
| c.) Combined Single Limit<br>(Bodily Injury and Property Damage): | <u>\$2,000,000</u> Each Accident |
|---|----------------------------------|

4. In addition to the requirements of Paragraph 5.04.B.1 of the General Conditions concerning the naming of the Owner, Engineer, and Engineer's consultants as additional insureds under the CONTRACTOR's General Liability Policy. Also, the CONTRACTOR shall at his expense provide an OWNER's and CONTRACTOR's Protective Liability Policy issued in the name of the OWNER and ENGINEER covering the CONTRACTOR's obligations under Paragraph 5.04.B.4 of the General Conditions. Coverage shall be provided under this policy for not less than the following amounts:

- |                      |                                     |
|----------------------|-------------------------------------|
| (1) Bodily Injury:   | <u>\$1,000,000</u> Each Occurrence  |
| (2) Property Damage: | <u>\$1,000,000</u> Each Occurrence  |
|                      | <u>\$1,000,000</u> Annual Aggregate |

#### SC-5.07

A. OWNER and CONTRACTOR intend that all policies purchased in accordance with paragraphs SC 5.06 will protect OWNER, CONTRACTOR, Subcontractors, ENGINEER, ENGINEER's Consultants and all other persons or entities identified in the Supplementary Conditions to be listed as insured or additional insureds (and the officers, directors, partners, employees, agents, and other consultants and subcontractors of each and any of them) in such policies and will provide primary coverage for all losses and damages caused by the perils or causes of loss covered thereby. All such policies shall contain provisions to the effect that in the event of payment of any loss or damage the insurers will have no rights of recovery against any of the insureds or additional insureds thereunder.

C. Any insurance policy maintained by CONTRACTOR covering any loss, damage or consequential loss referred to in this paragraph SC 5.07.B shall contain provisions to the effect that in the event of payment of any such loss, damage or consequential loss the insurers will have no rights of recovery against OWNER, Subcontractors, ENGINEER, ENGINEER's Consultants and the officers, directors, partners, employees, agents and other consultants and subcontractors of each and any of them.

**SC-6.06.B** The CONTRACTOR, , shall identify Subcontractors, Suppliers, or other persons or organizations as follows:

- 1) Prior to the Effective Date of the Agreement, the CONTRACTOR shall within seven (7) days of the receipt of a Written Request from the OWNER or the ENGINEER identify Subcontractors, Suppliers, or others specifically requested.
- 2) Within thirty (30) days following the Effective Date of the Agreement, all Subcontractors shall be identified.

**SC-6.06.C** OWNER or ENGINEER may furnish to any such Subcontractor, Supplier or other individual or entity, to the extent practicable, information about amounts paid to CONTRACTOR on account of work performed for Contractor by a particular Subcontractor, supplier, or other individual or entity.

**SC-6.13** The following paragraphs shall apply in addition to the requirements in 6.13 of the General Conditions:

CONTRACTOR agrees to waive any claim against OWNER and OWNER's agents, architects, engineers, consultants, and their employees acting within the scope of their duties, and to defend, indemnify, and hold them harmless from any claim or liability for injury or loss that allegedly arises from CONTRACTOR's performance of the work described herein. CONTRACTOR will require all SUBCONTRACTORS to conform with this provision before they start any work. CONTRACTOR shall insure this provision in conformity with the insurance provisions of this CONTRACT.

Until final acceptance of the Work by the ENGINEER as evidenced by approval of the final estimate, the Work shall be in the custody and under the charge and care of the CONTRACTOR and he shall take every necessary precaution against injury or damage to any part thereof by the action of the elements or from any other cause, whether arising from execution or from the non-execution of the Work, unless otherwise provided for elsewhere in the Specifications or Contract. The CONTRACTOR shall rebuild, repair, restore and make good, without extra compensation, all injuries or damages to any portion of the work occasioned by any of the above causes before its completion and acceptance, and shall bear the expenses thereof. In case of suspension of the Work from any cause whatever, the CONTRACTOR shall be responsible for all materials and equipment and shall properly store them if necessary and shall provide suitable shelter from damage and shall erect temporary structures where necessary.

**SC-11.03.C** Paragraph 11.03.C of the General Conditions is hereby deleted in its entirety and the following is substituted in its place:

"C. The unit price of an item of Unit Price Work shall be subject to reevaluation and adjustment under the following conditions:

1. If the total cost of a particular item of Unit Price Work amounts to five percent (5%) or more of the Contract Price and the variation in the quantity of that particular item of Unit Price Work performed by Contractor differs by more than twenty-five percent (25%) from the estimated quantity of such item indicated in the Agreement; and
2. If there is no corresponding adjustment with respect to any other item of Work; and
3. If CONTRACTOR believes that it has incurred additional expense as a result thereof; or if OWNER believes that the quantity variation entitles it to an adjustment in the Unit Price, either OWNER or CONTRACTOR may make a claim for an adjustment in the Contract Price in accordance with Article 10 if the parties are unable to agree as to the effect of any such variations in the quantity of Unit Price Work performed."

**SC-13.03.B** CONTRACTOR shall employ and pay for the services of an independent testing laboratory acceptable to the OWNER and the ENGINEER to perform all inspections, tests, or approvals required by the Contract Documents except:

1. that costs incurred in connection with tests or inspections conducted pursuant to paragraph 13.04.B of the General Conditions shall be paid as provided in said paragraph 13.04.B; and
2. as otherwise specifically provided in the Contract Documents.

**14.02.B.5** In addition to reasons listed in G.C. 14.02.B.5.a through 14.02.B.5.d, the ENGINEER may refuse to recommend the whole or any part of any payment to the CONTRACTOR because liability for liquidated damages has been incurred by the CONTRACTOR.

**S.C.-14.05.A** Add the following new paragraph immediately after paragraph 14.05.A.1 which is to read as follows:

2. OWNER may at any time request CONTRACTOR in writing to permit OWNER to take over operation of any such part of the Work although it is not substantially complete. A copy of such request will be sent to ENGINEER and within a reasonable time thereafter OWNER, CONTRACTOR and ENGINEER shall make an inspection of that part of the Work to determine its status of completion and will prepare a list of the items remaining to be completed or corrected thereon before final payment. If CONTRACTOR does not object in writing to OWNER and ENGINEER that such part of the Work is not ready for separate operation by OWNER, ENGINEER will finalize the list of items to be completed or corrected and will deliver such lists to OWNER and CONTRACTOR together with a written recommendation as to the division of responsibilities pending final payment between OWNER and CONTRACTOR with respect to security, operation, safety, maintenance, utilities, insurance, warranties and guarantees for that part of the Work which will become binding upon OWNER and CONTRACTOR at the time when OWNER takes over such operation (unless they shall have otherwise agreed in writing and so informed ENGINEER). During such operation and prior to Substantial Completion of such part of the Work, OWNER shall allow CONTRACTOR reasonable access to complete or correct items on said list and to complete other related Work.

**SC-17.01** In addition to the provisions of paragraph 17.01 of the General Conditions, written Notice to the CONTRACTOR shall be deemed to have been given if delivered in person to the CONTRACTOR's authorized representative on the project site.

END OF SECTION 00800.



## SECTION 00810

### SPECIAL CONDITIONS

#### 1. PERFORMANCE AND PAYMENT BONDS

The Contractor shall, along with the executed Contract, furnish the Owner with a Performance Bond and a Payment Bond in penal sums equal to the amount of the CONTRACT PRICE, conditioned upon the performance by the Contractor of all undertakings, covenants, terms, conditions and agreements of the Contract Documents, and upon the prompt payment by the Contractor to all persons supplying labor and materials in the prosecution of the work provided by the Contractor and a corporated bonding company licensed to transact such business in the state in which the work is to be performed and named on the current list of "Surety Companies Acceptable on Federal Bonds" as published in the Treasury Department Circular Number 570. The expense of these bonds shall be borne by the Contractor. If at any time a surety on any such Bond is declared a bankrupt or loses its rights to do business in the state in which the work is to be performed or is removed from the list of Surety Companies accepted on Federal Bonds, Contractor shall within ten (10) days after notice from the Owner to do so, substitute an acceptable bond (or bonds) in such form and sum and signed by such other surety or sureties as may be satisfactory to the Owner. The premiums on such bond shall not be deemed due nor shall be made until the new surety or sureties shall have furnished an acceptable bond to the Owner.

#### 2. INSPECTION FACILITIES

The Contractor shall at all times provide access to, and all means necessary to provide for inspection of all parts of the work by the Engineer.

#### 3. UTILITIES

The Contractor shall be responsible for any damage done by him or any of his subcontractors to all utilities within the limits of the work. It shall be his responsibility to locate and determine the depth of the existing utilities and manholes as far ahead of his operations as practicable and shall keep the Engineer informed of possible vertical and horizontal conflicts. The Engineer shall adjust the alignment and/or profile of the proposed facilities insofar as practically feasible to eliminate potential conflicts. Unavoidable conflicts will be eliminated as described below. Should any utilities or appurtenances be damaged by the Contractor's activities and operations under this contract, the Contractor shall cause the necessary repairs to be made and shall pay the entire cost thereof without compensation. Temporary repairs may be made by the Contractor to utilities damaged by his operations when such utilities are to be relocated, provided such temporary repairs are adequate to maintain the utility in service until the permanent relocation or adjustment is made.

No separate compensation shall be allowed the Contractor for any work required by this paragraph due to conflicts with lines and appurtenances or as a result of grade revisions.

- a. High Pressure Gas Lines: Where they interfere with work, high-pressure gas lines and appurtenances will be moved by the Okaloosa Gas Distric. The Contractor shall pay any charges made by the Gas District.
- b. Low Pressure Gas Lines: Where they interfere with work, low pressure gas lines and appurtenances will be moved by the Contractor at no expense to the Owner.
- c. Sanitary Sewers: Where they interfere with the work, existing sanitary sewer lines and laterals will be moved by the Contractor. The Contractor shall notify the Director of the Water and Sewer System at least twenty-four (24) hours prior to the initiation of any such relocation work.
- d. Water Lines: Where water lines interfere with the work they will be relocated by the Contractor. The Contractor shall notify the Director of the Water and Sewer System at least twenty-four (24) hours prior to the initiation of any such relocation work.
- e. Storm Drainage Pipe: The Contractor shall excavate a sufficient distance ahead of his work to allow the Engineer time and space to resolve conflicts with any storm drainage pipes which are not shown on the plans. It is the Contractor's responsibility to protect all existing storm drainage pipes which interfere with his operations. When the plans do not indicate the conflict and the Engineer finds that the conflict creates an undue hardship on the Contractor or calls for work outside the scope of the contract, the Engineer will determine the most appropriate method for resolving the conflict which is satisfactory to both the Owner and the Contractor. This additional work shall be handled by contract change order or field instructions by the Engineer or his representative depending upon the extent and cost of said additional work.

#### 4. CONTRACTOR'S RESPONSIBILITY FOR WORK

Until final acceptance of the work by the Owner, the work shall be in the custody and under the charge and care of the Contractor and he shall take every necessary precaution against injury or damage to any part thereof by the action of the elements or from any other cause, whether arising from execution or from the non-execution of the work, unless otherwise provided for elsewhere in the Contract Documents. The Contractor shall rebuild, repair, restore, and make good, without extra compensation, all injuries or damages to any portion of the work occasioned by any of the above causes before its completion and acceptance, and shall bear the expenses thereof. In case of suspension of the work from any cause whatever, the Contractor shall be responsible for all materials and equipment and shall properly store them, if necessary, and shall provide suitable shelter from damage and shall erect temporary structures where necessary.

#### 5. EXTRA CHARGES

Upon receiving a change order or field order, the Contractor shall notify the Engineer of any additional charges the Contractor feels he is due prior to initiating the work under consideration.

6. EXAMINATION OF PLANS, SPECIFICATIONS, SUPPLEMENTARY CONDITIONS, AND SITE WORK

Before submitting a proposal, bidders shall examine carefully the site of the proposed work, the general and local conditions, the proposal form, standard specifications, supplemental specifications, provisions, and the contract and bond forms, and it is mutually agreed that the submission of a proposal shall be prima facie evidence that the bidder has made such examination and has judged for and satisfied himself as to the surface and subsurface conditions to be encountered, as to the character, quality, and quantities of work to be performed and materials to be furnished, and as to the requirements of plans, standard specifications, supplemental specifications, special provision contract, and bonds. No adjustments or compensation will be allowed for losses caused by failure to comply with this requirement.

Bidders are advised that the Owner disclaims responsibility for any opinions, conclusions, interpretations, or deductions that may be expressed or implied in any of the information presented or made available to bidders; it being expressly understood that the making of deductions, interpretations, and conclusions from all of the accessible factual information is the bidder's sole responsibility.

7. SUBSURFACE CONDITIONS

The Contractor shall check all subsurface conditions and satisfy himself on those conditions before submitting a bid. Subsurface conditions discovered during construction shall not be a basis for extra compensation.

8. ENVIRONMENTAL CONTROL

The Contractor shall insure that good environmental protection practices and methods are instituted to protect surface waters from excessive silt, sediments and nutrients caused by his construction operations.

Storm drainage facilities and temporary dikes, checks, channelization, grassing and any other prudent control shall be installed in the initial stages and as necessary in order to fulfill the requirements set forth in the above regulations. The Contractor shall be responsible for all environmental damages caused by his operations.

Cost for complying with these regulations shall be considered incidental to the work on the bid schedule and no separate payment will be made.

9. PROSECUTION OF WORK

- a. All the work shall be prosecuted in a manner which according to local conditions shall be best calculated to promote rapidity in construction, to secure safety to life and property and also to reduce to a minimum any interference with abutting property or public travel.
- b. The Contractor shall conduct his operations diligently in all parts of the work, coordinating his part so that the completion of the work shall not be unnecessarily delayed.

#### 10. USE OF ADJOINING PROPERTY

Whenever it is necessary for the Contractor to occupy or otherwise use land adjacent to the work which is not the property of the Owner or for use of which no permit has been granted, the Contractor must make his own arrangements with the Owner of such property.

#### 11. SAFETY AND HEALTH REGULATIONS

The Contractor shall comply with the Department of Labor Safety and Health Regulations for construction promulgated under Occupational Safety and Health Act of 1970 (PL-91-596) and under Section 107 of the Contract Work Hours and Safety Standards Act (PL-91-54).

#### 12. OBSERVANCE OF LAWS AND REGULATIONS

The Contractor shall keep himself informed of all laws, ordinances, and regulations in any manner affecting those employed on the work, or the materials used in the work, or in any way affecting the conduct of the work, and of all orders and decrees of bodies or tribunals having any jurisdiction or authority over the same. He shall at all times himself observe and comply with, and shall require all his agents, employees and subcontractors to observe and comply with all such applicable laws, ordinances, regulations, orders and decrees in effect or which may become effective before completion of this contract; and shall protect and indemnify the Owner against any claim of liability arising from or based upon the violation of any such law, ordinance, regulation, order, or decree, whether by himself, his employees or his subcontractors. When local or state laws or ordinances conflict with federal laws or regulations, federal laws or regulations shall take precedence.

#### 13. FINAL CONSTRUCTION INSPECTION

Whenever the Contractor considers the work required by the contract is nearing completion and ready for use, he shall notify the Engineer and request an inspection of substantial completion. Within five (5) days after receiving the notification by the Contractor, the Engineer will inspect all work in the contract. If the Engineer finds that the work has been substantially completed, he will issue a letter of substantial completion. If the Engineer finds that the work has not been substantially completed at the time of such inspection, he will advise the Contractor in writing as to the work to be

done or the particular defects in the construction discovered during the inspection. After such work has been completed satisfactorily, the Engineer will re-inspect the work for substantial completion.

When the Contractor considers the work completed, he shall notify the Engineer and request a final inspection. Within five (5) days after receiving the notification by the Contractor, the Engineer shall conduct a final inspection. If the Engineer finds the work has been completed, he will issue a letter stating that the project is complete. If the Engineer finds that the work has not been completed at the time of the inspection, he will advise the Contractor in writing as to the work to be done to complete the project. After such work has been satisfactorily completed, the Engineer will re-inspect the work. When the Engineer considers the work complete, he will issue a letter of final completion.

#### 14. EQUIPMENT AND MATERIALS REMOVED

All equipment and materials removed and/or replaced in the contract which the Owner wants shall become the property of the Owner and shall be placed at a location on the site designated by the Owner. All other equipment and materials which the Owner does not want shall be disposed of off-site at the expense of the Contractor. The Owner shall be final judge of what is salvageable.

#### 15. REMOVAL OF DEBRIS

The Contractor shall frequently clean up all refuse, rubbish, scrap materials and debris caused by his operations, so that at all times the site of the work shall present a neat, orderly and workmanlike appearance.

#### 16. TEMPORARY ROADS, DETOURS AND MAINTENANCE OF ACCESS

- a. Detours and temporary structures necessary for travel during the prosecutions of the work will be at the expense of the Contractor.
- b. No section of the work shall be closed to traffic unless approved by the Engineer. Suitable signs indicating "Road Closed" or "Detour" shall be erected by the Contractor as ordered by the Engineer at no expense.
- c. If in the opinion of the Engineer the Contractor does not comply with the above requirements such work as the Engineer may deem necessary may be performed by others at the direction of the Engineer and the charges therefor held from any money due or to become due to the Contractor on this or any other Contract.

#### 17. RESTORATION OF THE GROUNDS

As the work progresses and whenever so directed by the Engineer, the Contractor is to remove all surplus material and completely restore to good condition, all surface, disturbed, destroyed or removed by the Contractor, or his agent, or on account of construction. When the Contractor fails to promptly restore the streets or other property,

the Engineer, after having given three (3) days notice to the Contractor shall have the work shut down until the streets and other property have been restored. Loss of time due to such shut-down will not entitle the Contractor to any extension of time or extra compensation.

Before final inspection is made, all surfaces disturbed on account of this construction shall be leveled up and all surplus material and rubbish incident to the construction must be removed and disposed of and streets, gutters, ditches, sidewalks, crossings, railroads, grass plots and other property affected by the Construction shall be left in good and acceptable condition.

#### 18. UNDERGROUND UTILITIES AND SERVICES

The plans show certain features of the topography and certain underground utilities, but they do not purport to show in detail all such lines or obstructions. Such topography and notes on the plans were inserted from records available and are for the Contractor's convenience only, and shall not be used as basis for any claims of extra compensation.

All pipes or other underground utilities shall be maintained in continuous service where possible and shall be properly protected and supported. In no case shall interruptions to utilities be allowed to exist outside of working hours.

Prior to starting the work, the proper authorities of all utilities shall be notified by the Contractor and the Contractor shall cooperate in every way possible with these authorities. Whenever necessary to determine the location of existing pipes, valves or other underground structures, the Contractor shall examine all available records and shall make all explorations and excavations necessary for such purpose.

#### 19. CHEMICALS

All chemicals used during project construction or furnished for project operation, whether herbicide, pesticide, disinfectant, polymer, reactant or other classification, must show approval of either EPA or USDA. Use of such chemicals and disposal of residues shall be in strict conformance with manufacturer's instructions.

#### 20. COOPERATION BETWEEN CONTRACTORS

Contractor shall cooperate to the fullest extent in order to expedite the completion of the entire project. Any contractor deemed by the Engineer to be in violation of this clause can be subject to disciplinary action including but not limited to fines to be paid to the Owner or direct payment to other contractors.

#### 21. DAMAGE BETWEEN CONTRACTORS

If a Contractor damages any of the work performed by another contractor, that contractor causing the damage shall replace, repair, or make any other compensation deemed appropriate by the Engineer to the Contractor who did the original work.

## 22. PROJECT WARRANTY

The five-year warranty period provided under this contract shall begin on the date of the final inspection when the Engineer certifies the project substantially complete. In accordance with Section 29 of the General Conditions, this warranty shall cover defects in all material, equipment, and labor furnished under this contract.

All manufacturers of equipment furnished under this contract shall, as a minimum, provide separate warranties to both the Owner and the Contractor covering all parts, labor, shipping and handling charges for repairing or replacing equipment which proves defective during normal use for

1. Five years from date of shipment, or
2. Five years from date of substantial completion, whichever occurs earlier regardless of the date the equipment is placed in interim service.

Included in each equipment manufacturer's submittal data shall be a certified statement that the manufacturer will comply with the above warranty provisions. In the event that the manufacturer's warranty expires prior to the Contractor's warranty, the Contractor shall assume full responsibility for all equipment warranties to the Owner for the remainder of the contract warranty period.

END OF SECTION 00810.

Poly, Inc. - G:\CLEANSTUFF-29-6999\49056 CRESTVIEW SIGNS\WP101-GENERAL\49056\_G1.0.dwg [Layout1] Last Printed: December 19, 2018 - 09:13am By: cwilks

# BID DOCUMENTS FOR

# NEW GATEWAY PLANTER SIGN FOR THE CITY OF CRESTVIEW, FLORIDA



## CRA BOARD MEMBERS

### DIRECTOR

ALISA BURLESON

### COMMISSIONERS

J.B. WHITTEN - CHAIRMAN

BILL COX - VICE CHAIRMAN

JOE BLOCKER

SHANNON HAYES

DOUG FAIRCLOTH

RON GAUTNEY

DR. MARGARETH LAROSE-PIERRE

CAROL LEONE - BOARD ATTORNEY



DECEMBER 2018  
Job No. 49056



Revision	Date	Description

DATE: DECEMBER 2018  
REGISTRATION No.

DESIGNED BY: CIVIL  
ENG / ARCHT / SURVEYOR OF RECORD:

These drawings are copyrighted and the property of Poly, Inc. No part of this drawing may be reproduced or transmitted in any form or by any means, partial or full, without the prior written permission of Poly, Inc. Agreement with Poly, Inc.

Cent. of Auth. No. GA  
FL  
CA  
AL  
IA  
IL  
IN  
MI  
MO  
ND  
OH  
PA  
SC  
TN  
TX  
VA  
WI  
WV  
KY

ARCHITECT: CA-0480  
ENGINEER: CA-784E  
SURVEY: CA-0784.E.LAT927

1936 Headland Avenue  
Dothan, AL 36803  
334-793-4700

102 Sunset Lane  
Shalimar, FL 32579  
850-669-1100

2135 University Blvd. Ste. A  
Tuscaloosa, AL 35401  
205-752-4037

WWW.POLY-INC.COM

NEW GATEWAY AND WAYFINDING SIGNAGE  
THE CITY OF CRESTVIEW, FLORIDA

COVER SHEET

SHEET No.  
**G1.0**  
PROJECT No.  
49-056

BID DOCUMENTS



Poly, Inc. - G:\CLEANSTUFF-29-89949056 CRESTVIEW SIGNS\WP01-GENERAL\49056\_G1.dwg [Layout1] Last Printed: December 19, 2018 - 09:12am By: cwilks



**INDEX OF DRAWINGS**

**GENERAL:**  
 G1.0 COVER  
 G1.1 VICINITY MAP, LEGEND AND INDEX OF DRAWINGS

**ARCHITECTURAL:**  
 A1.0 SITE PLAN, NOTES AND SPECIFICATIONS  
 A1.1 ELEVATIONS AND PLANS  
 A1.2 SECTIONS AND DETAILS

**STRUCTURAL:**  
 S1.1 FOUNDATION PLAN AND SECTIONS

**ELECTRICAL:**  
 E-1.0 ELECTRICAL PLANS

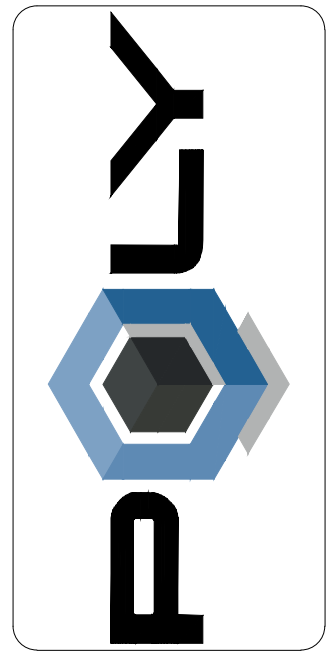

Revision	Description	Date

DESIGNED BY:	CWV	DATE:	DECEMBER 2018
DRAWN BY:	CWV	REGISTRATION NO.:	
ENG ARCHT / SURVEYOR OF RECORD:		These drawings are copyrighted and the property of Poly, Inc. No part of these drawings may be reproduced or transmitted in any form or by any means, partial or full, without the prior written permission of Poly, Inc. Agreement with Poly, Inc.	
Crt. of Auth. No.:		FL:	CA1818
ARCHITECT:	CA-0480	GA:	LS00032
ENGINEER:	CA-784E		
SURVEY:	CA-0784E		

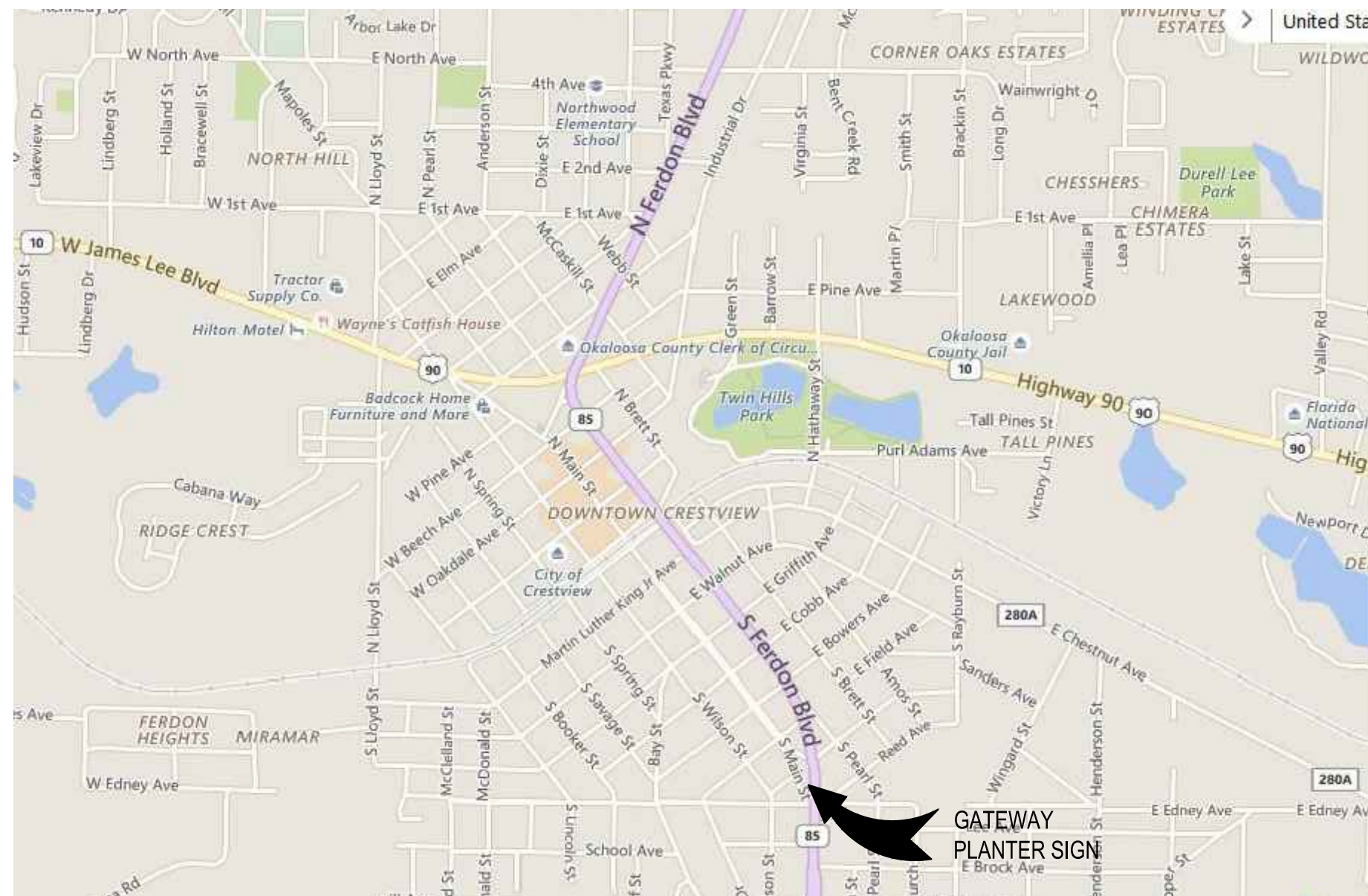

TOWN OF CRESTVIEW



GATEWAY PLANTER SIGN

**LEGEND**

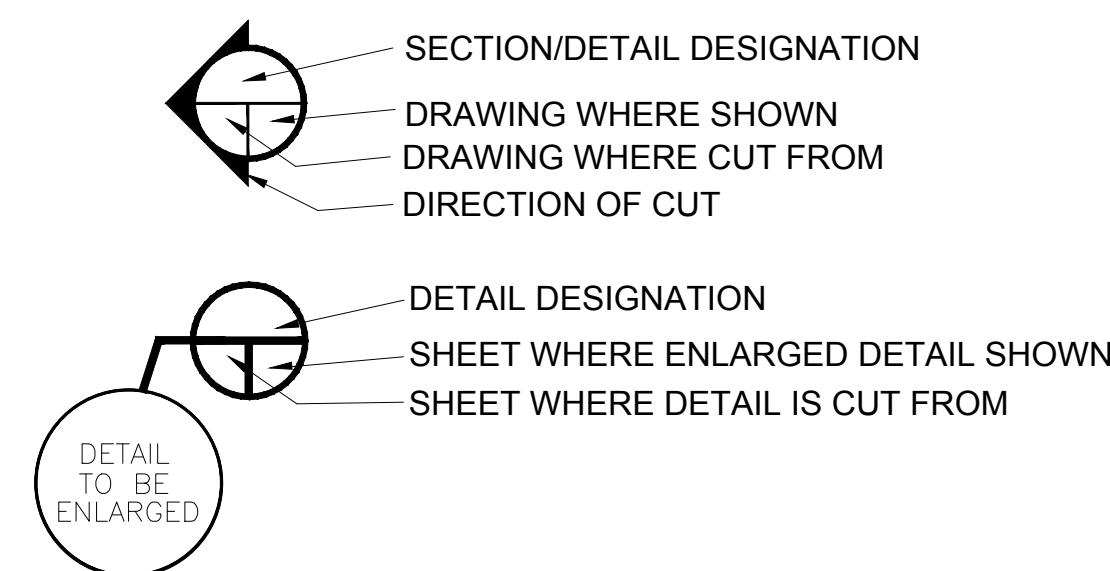

**POLY, INC.**  
 1936 Headland Avenue  
 Dothan, AL 36803  
 334-793-7700

102 Sunset Lane  
 Tallahassee, FL 32309  
 904-844-4007

2135 University Blvd, Ste. A  
 Tallahassee, FL 32309  
 904-844-4007

WWW.POLY-INC.COM

NEW GATEWAY AND WAYFINDING SIGNAGE  
 THE CITY OF CRESTVIEW, FLORIDA

INDEX OF DRAWINGS &  
 VICINITY MAP

SHEET No.  
**G1.1**  
 PROJECT No.  
 49-056

**BID DOCUMENTS**

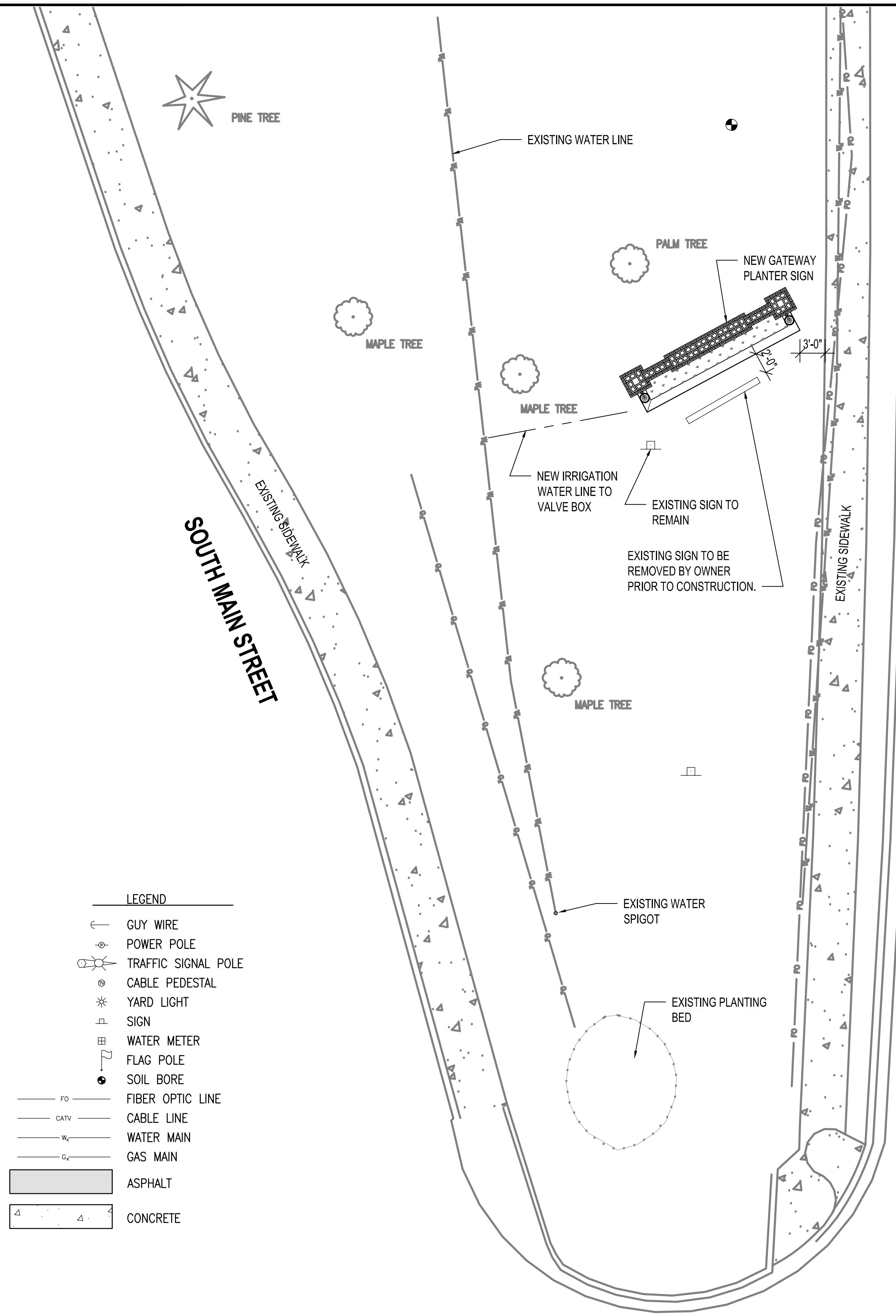

LEGEND	
	GUY WIRE
	POWER POLE
	TRAFFIC SIGNAL POLE
	CABLE PEDESTAL
	YARD LIGHT
	SIGN
	WATER METER
	FLAG POLE
	SOIL BORE
	FIBER OPTIC LINE
	CABLE LINE
	WATER MAIN
	GAS MAIN
	ASPHALT
	CONCRETE

**SITE PLAN**  
SCALE: 1/8" = 1'-0"

## ARCHITECTURAL NOTES AND SPECIFICATIONS

- GENERAL**
- CONTRACTOR SHALL PROVIDE ALL LABOR AND MATERIALS FOR CONSTRUCTION OF SIGN UNLESS OTHERWISE NOTED.
  - CONTRACTOR SHALL ACQUIRE BUILDING PERMIT FROM THE CITY.
  - SOME BUILDING MATERIALS INCLUDING BRICK VENEER AND CAST STONE MAY BE OBTAINED FROM OWNER FROM A SURPLUS OF MATERIALS FROM RECENTLY COMPLETED OKALOOSA COUNTY COURTHOUSE. ALL OTHER MATERIALS WILL BE SUPPLIED BY CONTRACTOR.
  - CONTRACTOR SHALL SUBMIT INFORMATIONAL DATA ON EACH OF THE ITEMS LISTED BELOW TO ARCHITECT. SEE STRUCTURAL AND ELECTRICAL DRAWINGS FOR ADDITIONAL REQUIRED SUBMITTALS. ARCHITECT / ENGINEERS WILL REVIEW SUBMITTALS FOR COMPLIANCE WITH THE DESIGN.

- EXISTING CONDITIONS**
- CONTRACTOR SHALL FIELD VERIFY THE LOCATIONS OF UTILITIES PRIOR STARTING WORK. REFER TO SITE PLAN.

- FOUNDATIONS**
- SEE STRUCTURAL DRAWINGS FOR COMPACTION AND PREPARATION OF SOILS UNDERNEATH FOOTINGS.
  - SEE STRUCTURAL DRAWINGS FOR FOUNDATION SIZING.

- CAST STONE**
- CAST STONE SHAPE "A" MAY BE OBTAINED FROM OWNER.
  - ANY NEW CAST STONE SHALL BE MANUFACTURED BY AN EXPERIENCED CAST STONE MANUFACTURER WHICH PRODUCES CAST STONE IN ACCORDANCE WITH ASTM C1364.
  - CAST STONE COLOR AND FINISH SHALL BE SAME AS COURTHOUSE.
  - CONTRACTOR MAY USE SAME CAST STONE MANUFACTURER WHICH PRODUCED CAST STONE FOR THE OKALOOSA COUNTY COURTHOUSE. THEIR CONTACT IS BLEOW:
- FLORIDA ARCHITECTURAL PRECAST  
2640 SOUTH KINGS HIGHWAY  
FORT PIERCE, FLORIDA 34945  
772-489-0920 PHONE, 772-489-0940 FAX

- BRICK VENEER**
- SOME BRICK AND MORTAR MAY BE OBTAINED FROM OWNER. IF NEEDED, CONTRACTOR SHALL PROVIDE ADDITIONAL BRICK AND MORTAR SHALL MATCH.
  - ALL BRICK WORK SHALL BE DONE BY AN EXPERIENCED MASON TO PRODUCE NEAT AND CONSISTENT MORTAR JOINTS.
  - ALL MORTAR SHALL BE TYPE "S" UNLESS NOTED OTHERWISE ON STRUCTURAL DRAWINGS.
  - PROVIDE AND INSTALL BRICK ANCHORS AT 16" O.C. VERTICAL SPACING AND 32" O.C. HORIZONTAL SPACING AT BRICK AND 4" CMU VENEER.

- METALS**
- STANDING SEAM METAL ROOFING SHALL BE FIELD CRIMPED, 24 GAUGE WITH 30 YEAR SMOOTH, PAINT FINISH. COLOR SHALL BE SELECTED BY OWNER.
  - METAL ROOFING SHALL BE NEATLY CRIMPED, PANELS SHALL BE FREE OF SCRATCHES AND DENTS.
  - STANDING SEAM ROOFING SHALL BE INSTALLED IN ACCORDANCE WITH MANUFACTURER'S WRITTEN INSTRUCTIONS.
  - ROOFING UNDERLAYMENT SHALL BE INSTALLED UNDER METAL PANELS AS REQUIRED BY PANEL MANUFACTURER.

- WOOD**
- ALL LUMBER AND PLYWOOD SHALL BE PRESSURE TREATED.
  - ALL NAILS SHALL BE GALVANIZED.
  - SCREWS SHALL HAVE COATING FOR USE WITH TREATED LUMBER.

- EXTERIOR INSULATION FINISHING SYSTEM (EIFS)**
- EIFS SHALL BE INSTALLED BY AN EXPERIENCED EIFS INSTALLER IN ACCORDANCE WITH MANUFACTURER'S WRITTEN INSTRUCTIONS.
  - WATER BARRIER SHALL BE OF TYPE ACCEPTABLE TO EIFS MANUFACTURER.
  - MOULDING SHAPES SHALL MATCH DESIGN INDICATED. SHAPES SHALL BE NEATLY AND EVENLY FORMED WITHOUT UNSIGHTLY VARIATIONS IN PROFILE.
  - STUCCO COLOR AND FINISH SHALL MATCH NEARBY OKALOOSA COUNTY COURTHOUSE LOCATED IN DOWNTOWN CRESTVIEW, FLORIDA.

- PLANTER SOIL MIX**
- SOIL MIX SHALL BE MIRACLE GROW POTTING MIX OR EQUAL.

- IRRIGATION SYSTEM**
- IRRIGATION SYSTEM SHALL BE INSTALLED BY AN EXPERIENCED IRRIGATION SUB-CONTRACTOR WHO FREQUENTLY INSTALLS LANDSCAPE AND IRRIGATION SYSTEMS.
  - BASIS OF DESIGN: RAIN BIRD SYSTEM WITH PROGRAMMABLE CONTROLLER AND VALVES
  - SYSTEM SHALL HAVE ONE ZONE FOR PLANTER AREA WITH DRIP SYSTEM INSTALLED THROUGHOUT.
  - TAP OFF OF WATER PIPE FEEDING NEARBY WATER SPIGOT. REFER TO SITE PLAN.

- CAST ALUMINUM LETTERS**
- BASIS OF DESIGN : LEEDS ARCHITECTURAL LETTERS, INC.  
WWW.LEEDSLETTERS.COM  
TYPEFACE: ARCHITECTURAL 113  
MOUNTING: PM - TYPE 1, PROJECTED MOUNTING  
COLOR: SELECTED BY OWNER  
TEXT SIZE: AS INDICATED ON DRAWINGS

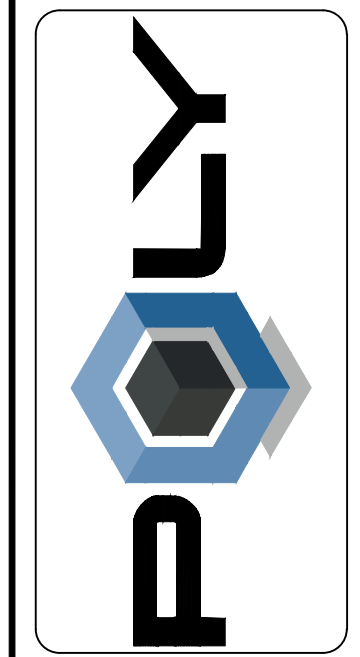

NO.	REVISION	DATE

DESIGNED BY: KLR	DATE: DECEMBER 2018
ENG / ARCH / SURVEYOR OF RECORD: CAW	REGISTRATION No.:
Cert. of Auth. No.:	

**POLY, INC.**  
1935 Redwood Avenue  
Duluth, GA 30033  
304-793-7020

103 Street Lane - 2135 University Blvd. Ste. A  
Shakopee, FL 32579 Telephone: 206-792-4037  
889-699-1000 Fax: 206-792-4037

WWW.POLY-INC.COM

NEW GATEWAY AND WAYFINDING SIGNAGE FOR THE CITY OF CRESTVIEW, FLORIDA

SITE PLAN, NOTES & ARCHITECTURAL SPECIFICATIONS

SHEET No.  
**A1.0**  
PROJECT No.  
49-056



Poly, Inc. - G:\CLEANSTUFF-29-999\46966 CRESTVIEW SIGNSWIP\06-ARCHITECTURAL\A1.2-Planter-Details.dwg [Layout] Last Printed: December 19, 2018 - 09:56am By: cwilks

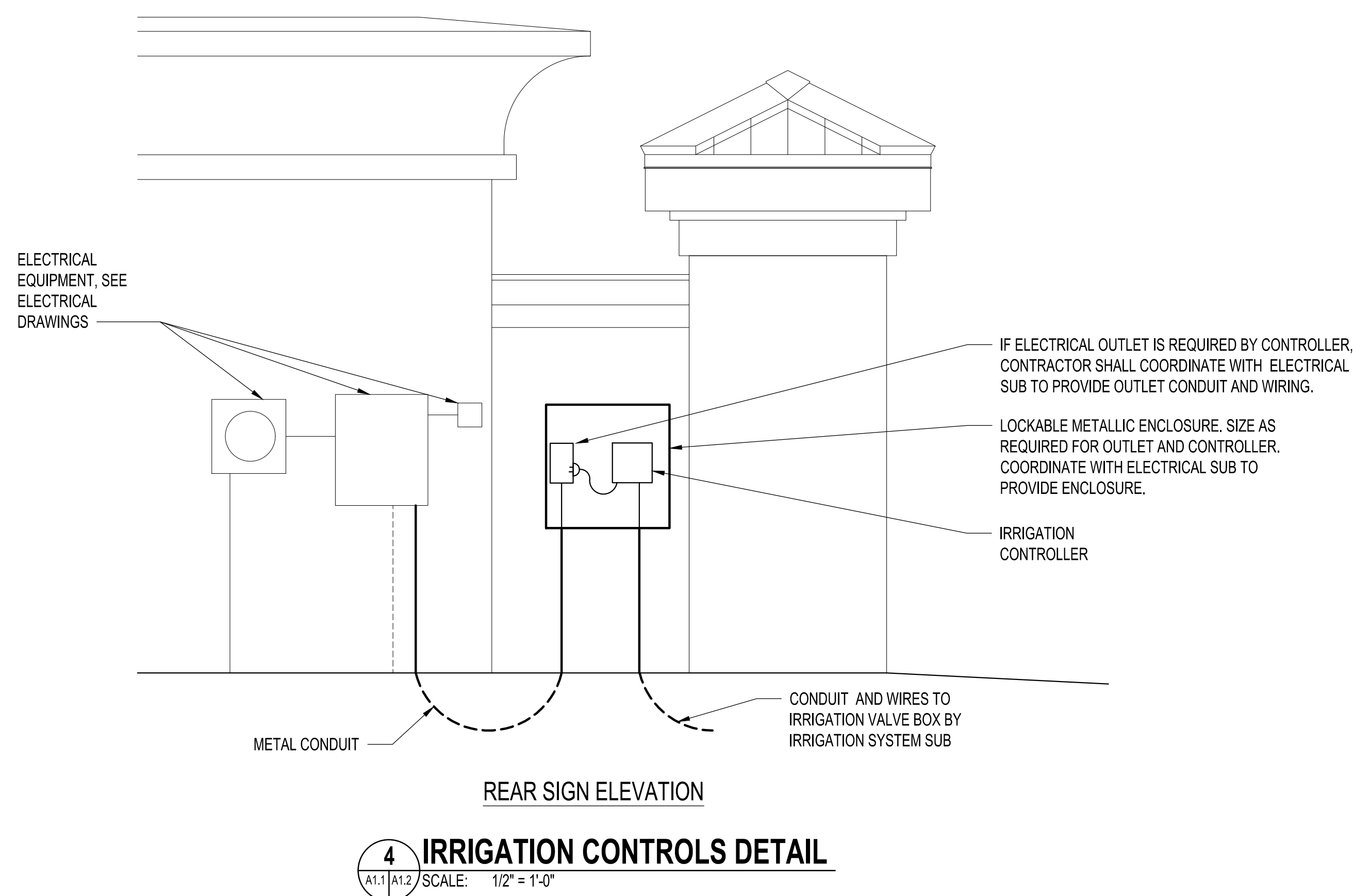
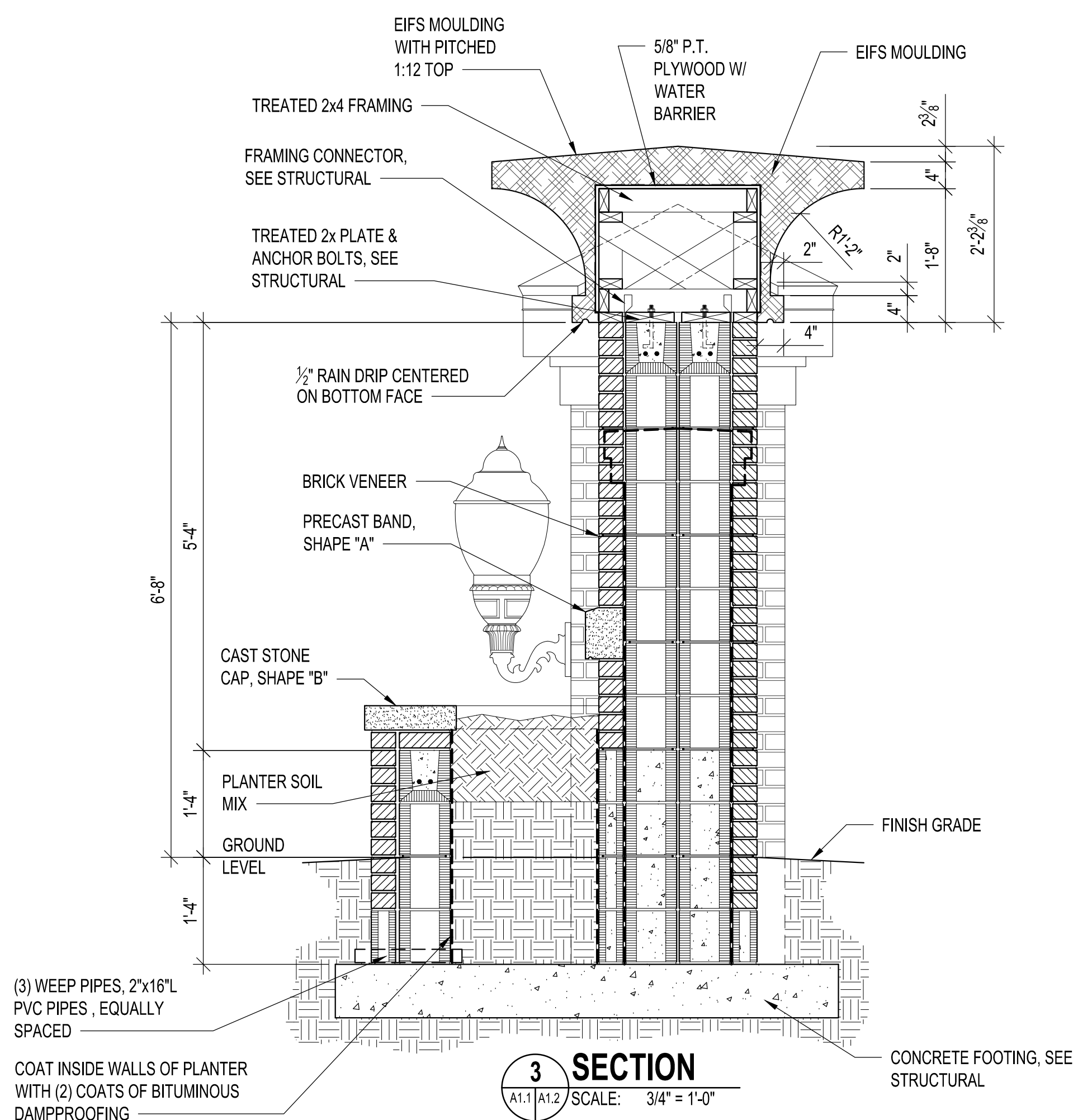
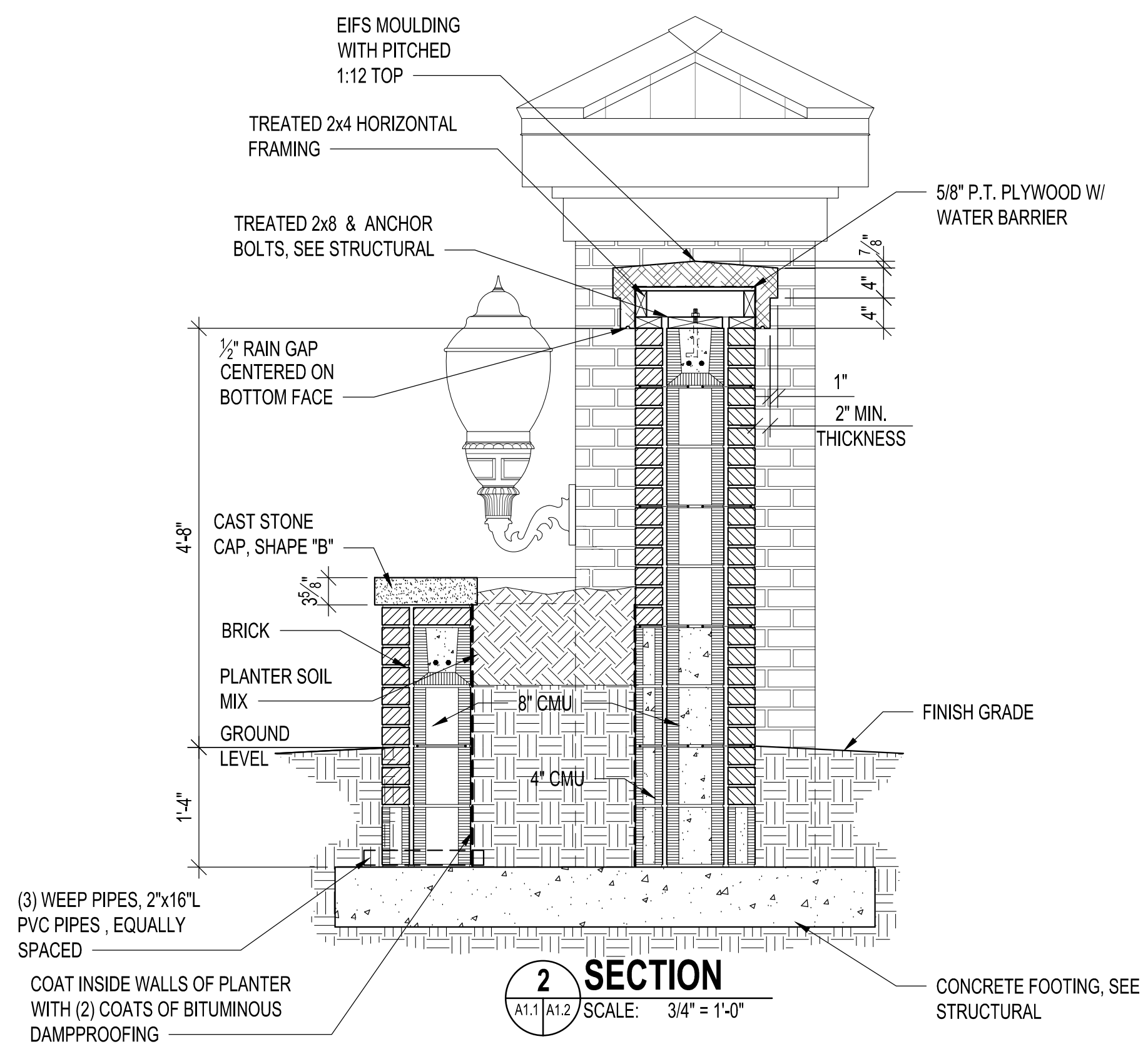
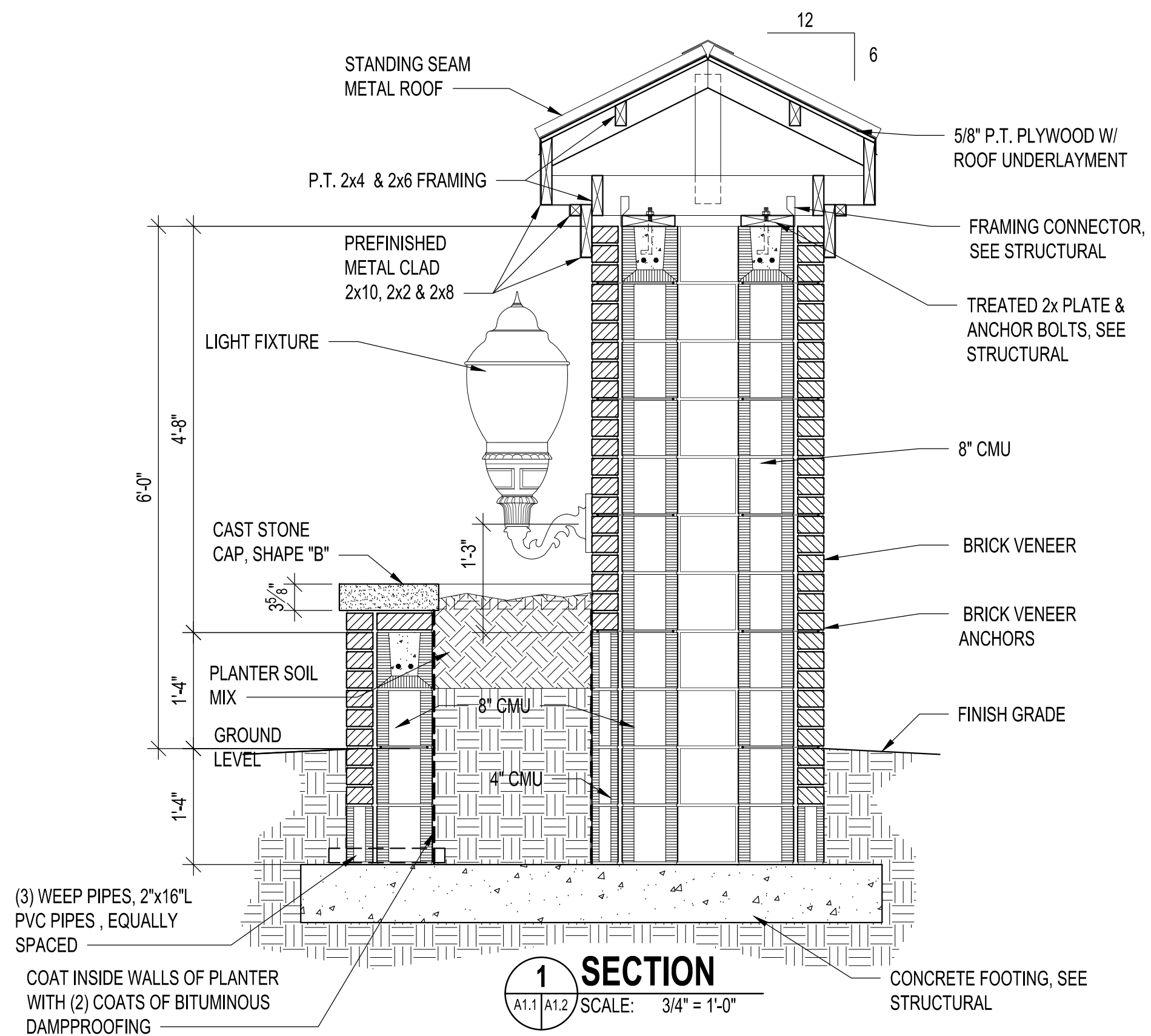

NO.	DATE	REVISION

DATE: DECEMBER 2018  
DESIGNED BY: JEB  
DRAWN BY: JEB  
REGISTRATION No.:  
CERT. OF AUTH. No.:  
ARCHITECT (CA) 0406 (CA) 00051 (001118)  
ENGINEER (CA) 74E (CA) 818 (001118)  
SURVEY (CA) 09A (LI) 8727 (LS) 90132  
These drawings are the property of Poly, Inc. and the property of Poly, Inc. and the property of Poly, Inc. No part or full reproduction is prohibited except by written agreement with Poly, Inc.

POLY, INC.  
1935 Highland Avenue  
Duluth, GA 30120  
102 Street Lane - 2156 University Blvd. Ste. A  
Shakopee, FL 32879 Telephone: 205-792-2037  
889-699-1000 FAX: 205-792-2037  
WWW.POLY-INC.COM  
NEW GATEWAY AND WAYFINDING SIGNAGE  
FOR  
THE CITY OF CRESTVIEW, FLORIDA  
SECTIONS AND DETAILS

SHEET No.  
A1.2  
PROJECT No.  
49-056

BID DOCUMENTS

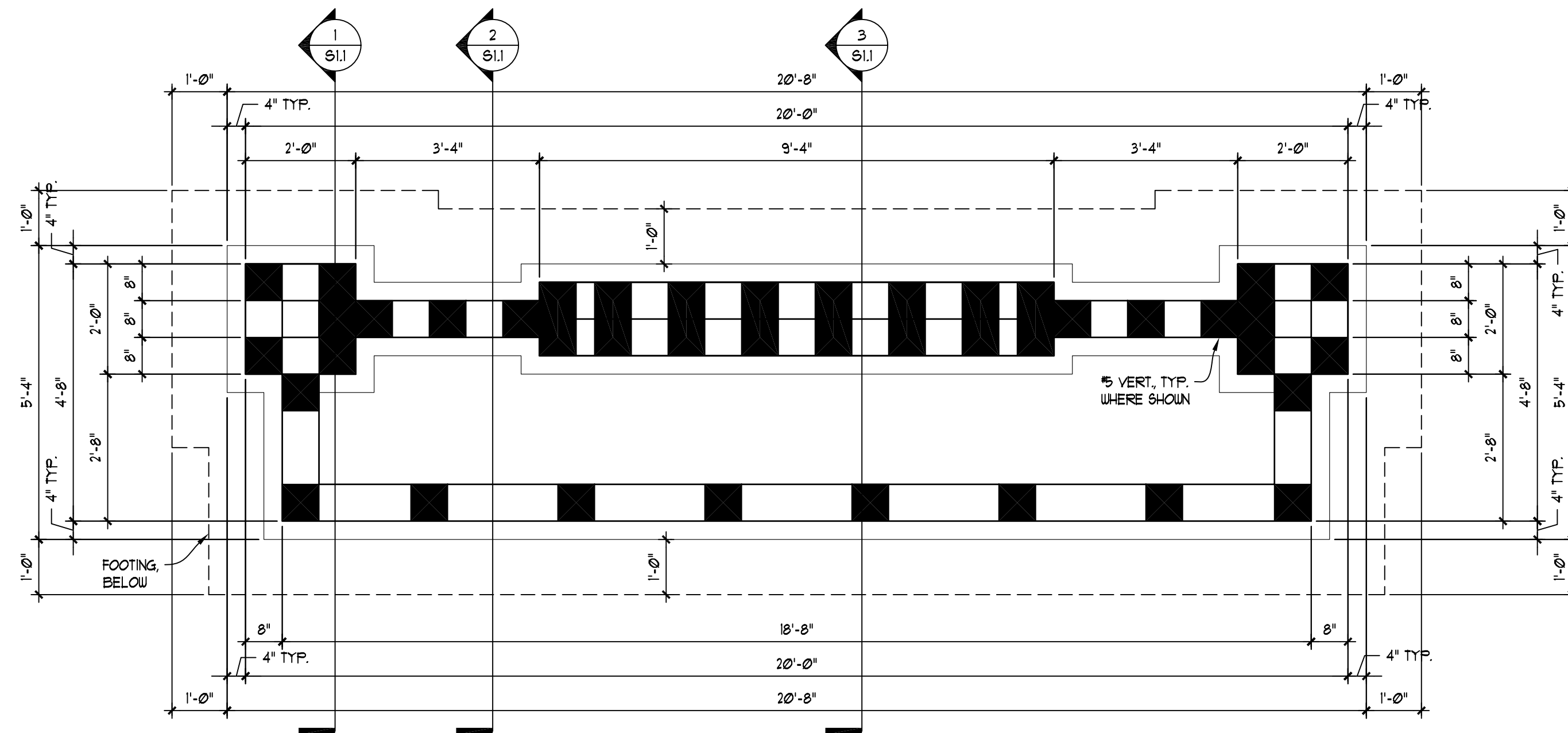

**GATEWAY PLANTER SIGN FOUNDATION PLAN**  
SCALE: 1/2"=1'-0"

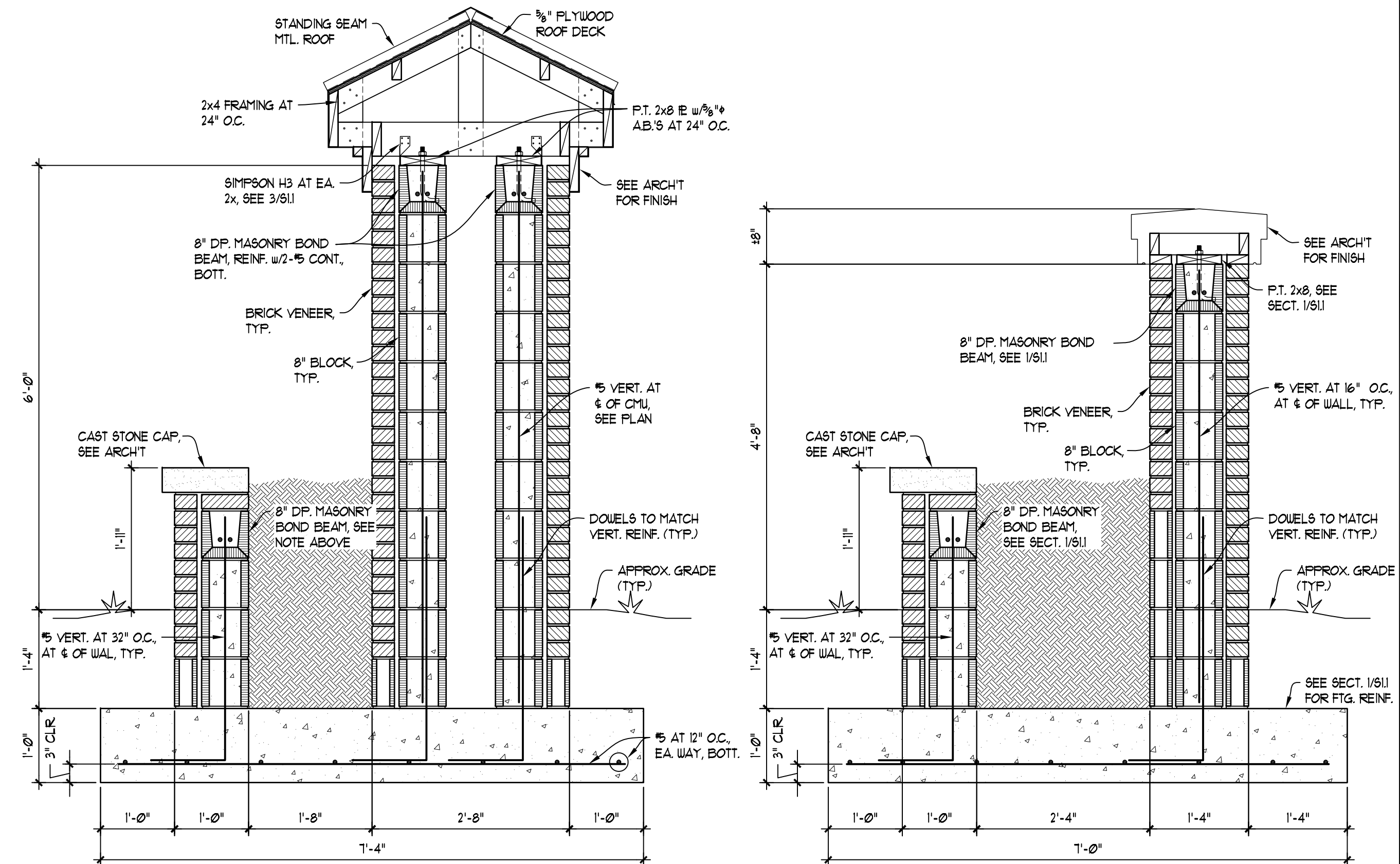

**SECTION 1**  
SCALE: 3/4"=1'-0"  
S11

**SECTION 2**  
SCALE: 3/4"=1'-0"  
S11

**GENERAL STRUCTURAL NOTES**

**GENERAL**

- NO PROVISION OF ANY REFERENCED STANDARD SPECIFICATION MANUAL OR CODE (WHETHER OR NOT SPECIFICALLY INCORPORATED BY REFERENCE IN THE CONTRACT DOCUMENTS) SHALL BE EFFECTIVE TO CHANGE THE DUTIES AND RESPONSIBILITIES OF OWNER, CONTRACTOR, ENGINEER OR SUPPLIER OR ANY OF THEIR CONSULTANTS, AGENTS OR EMPLOYEES FROM THOSE SET FORTH IN THE CONTRACT DOCUMENTS, NOR SHALL IT BE EFFECTIVE TO ASSIGN TO THE STRUCTURAL ENGINEER OF RECORD OR ANY OF THE STRUCTURAL ENGINEER OF RECORD'S CONSULTANTS, AGENTS, OR EMPLOYEES ANY DUTY OR AUTHORITY TO SUPERVISE OR DIRECT THE FURNISHING OR PERFORMANCE OF THE WORK OR AUTHORITY TO UNDERTAKE RESPONSIBILITIES CONTRARY TO THE PROVISIONS OF THE CONTRACT DOCUMENTS.
- THE GENERAL CONTRACTOR SHALL VERIFY THE DIMENSIONS AND SITE CONDITIONS BEFORE STARTING WORK. THE ARCHITECT/STRUCTURAL ENGINEER OF RECORD SHALL BE NOTIFIED OF ANY DISCREPANCY.
- MATERIALS AND WORKMANSHIP SHALL CONFORM TO THE SIXTH EDITION (2011) FLORIDA BUILDING CODE.
- THE CONTRACTOR SHALL COORDINATE THE ARCHITECTURAL, ELECTRICAL AND CIVIL WORKS WITH THE STRUCTURAL CONTRACT DOCUMENTS. ARCHITECT/STRUCTURAL ENGINEER OF RECORD SHALL BE NOTIFIED OF ANY DISCREPANCIES OR OMISSIONS.
- THE CONTRACTOR SHALL NOTIFY IN WRITING THE STRUCTURAL ENGINEER OF RECORD OF CONDITIONS ENCOUNTERED IN THE FIELD CONTRADICTORY TO THOSE SHOWN ON THE STRUCTURAL CONTRACT DOCUMENTS.
- FOR DIMENSIONS NOT SHOWN ON THE STRUCTURAL CONTRACT DOCUMENTS SEE THE ARCHITECTURAL.
- THE CONTRACTOR SHALL BE RESPONSIBLE FOR INITIATING, MAINTAINING AND SUPERVISING ALL SAFETY PRECAUTIONS AND PROGRAMS IN CONNECTION WITH THE PERFORMANCE OF THE CONTRACT. THE CONTRACTOR SHALL GIVE NOTICES AND COMPLY WITH ALL APPLICABLE LAWS, ORDINANCES, RULES, REGULATIONS AND LAWFUL ORDER OF PUBLIC AUTHORITIES (ESPECIALLY OSHA) BEARING ON SAFETY OF PERSONS OR PROPERTY OR THEIR PROTECTION FROM DAMAGE, INJURY OR LOSS. THE CONTRACTOR SHALL NOT LOAD OR PERMIT ANY PART OF THE CONSTRUCTION SITE TO BE LOADED SO AS TO ENDANGER ITS SAFETY.
- IN NO CASE SHALL STRUCTURAL ALTERATIONS OR WORK AFFECTING A STRUCTURAL MEMBER BE MADE, UNLESS APPROVED BY JOHNSON AND ASSOCIATES ENGINEERING IN WRITING.

**FOUNDATION**

- THE FOUNDATION IS DESIGNED AS A SHALLOW SPREAD FOUNDATION SYSTEM WITH AN ASSUMED ALLOWABLE SOIL BEARING PRESSURE OF 2000 PSF. THE STRUCTURAL ENGINEER OF RECORD IS NOT RESPONSIBLE FOR SUBSURFACE CONDITIONS ENCOUNTERED IN THE FIELD CONTRARY TO THOSE ASSUMED FOR DESIGN.
- THE CONTRACTOR SHALL VERIFY THE AVAILABLE SOIL BEARING CAPACITY AT FOOTING SUBGRADE ELEVATION, PRIOR TO COMMENCEMENT OF FOOTING CONCRETE OPERATIONS, BY PERFORMING HAND PENETROMETER TESTS. THE HAND PENETROMETER TESTS SHALL BE PERFORMED AT EACH ISOLATED COLUMN FOOTING AND ALONG ALL CONTINUOUS FOOTINGS AT THE RATE OF ONE TEST PER 25 LINEAR FEET. THE ENGINEER OF RECORD SHALL BE NOTIFIED IMMEDIATELY OF ALL SOIL BEARING TEST RESULTS. IF THE SUBGRADE SOIL IS DETERMINED TO BE INADEQUATE TO SUPPORT THE ASSUMED BEARING CAPACITY, THE CONTRACTOR SHALL IMMEDIATELY SUSPEND CONSTRUCTION OPERATIONS AND CONTACT THE STRUCTURAL ENGINEER OF RECORD SO THAT THE FOUNDATION SYSTEM CAN BE RE-DESIGNED TO SUIT FIELD CONDITIONS. THE STRUCTURAL ENGINEER OF RECORD IS NOT RESPONSIBLE FOR SUBSURFACE CONDITIONS ENCOUNTERED IN THE FIELD CONTRARY TO THOSE ASSUMED FOR DESIGN.
- FOOTING SUBGRADE SHALL BE COMPACTED TO A MINIMUM OF 95% MODIFIED PROCTOR DENSITY (ASTM D-1557) TO A DEPTH OF 12" BELOW BOTTOM OF FOOTING.

**CONCRETE**

- CONCRETE WORK SHALL CONFORM TO THE ACI 318-II AND CRSI STANDARDS.
- REFER TO ARCHITECTURAL DRAWINGS FOR MOLDS, GROOVES, ORNAMENTS, CLIPS, OR GROUNDS REQUIRED TO BE ENCASED IN CONCRETE AND FOR LOCATION AND DETAILS OF FLOOR FINISHES AND SLAB DEPRESSIONS.
- CONCRETE SHALL HAVE THE FOLLOWING MINIMUM 28 DAY COMPRESSIVE STRENGTH UTILIZING TYPE I CEMENT:  
FOUNDATIONS AND SLABS ON GRADE 3000 PSI

**REINFORCING STEEL**

- REINFORCING STEEL SHALL CONFORM TO ASTM A615-GRADE 60.
- WELDED WIRE FABRIC SHALL CONFORM TO ASTM A105 AND HAVE A MINIMUM SIDE LAP OF 8 INCHES.
- REINFORCEMENT SHALL BE SPLICED ONLY AS SHOWN OR NOTED IN THE STRUCTURAL CONTRACT DOCUMENTS.
- ALL REINFORCING LAP SPLICES SHALL BE A MINIMUM OF 36 BAR DIAMETERS IN LENGTH FOR REINFORCED CONCRETE. LAP SPLICES FOR REINFORCED MASONRY SHALL BE A MINIMUM OF 48 BAR DIAMETERS.
- ALL REINFORCING STEEL AND ACCESSORIES SHALL BE DETAILED, FABRICATED, AND PLACED IN ACCORDANCE WITH THE LATEST EDITION OF THE ACI MANUAL AND MANUAL OF STANDARD PRACTICE FOR DETAILING REINFORCED CONCRETE STRUCTURES.
- MINIMUM CONCRETE COVER FOR REINFORCING BARS SHALL BE IN CONFORMANCE WITH CHAPTER 7 OF ACI 318-II EXCEPT AS OTHERWISE NOTED.
- REINFORCING IN ALL CONCRETE WALLS, FOOTINGS AND BOND BEAMS SHALL BE CONTINUOUS AT INTERSECTIONS AND CORNERS. WHERE WALL FOOTINGS STEP, REINFORCING SHALL BE CONTINUOUS IN STEP.
- AT POURED CONCRETE WALLS, PIERS AND COLUMNS, DOUELS FOR VERTICAL REINFORCING BARS SHALL BE INSTALLED IN THEIR PROPER LOCATION PRIOR TO CONCRETE POUR OF THE FOOTINGS.

**STRUCTURAL METALS**

- STRUCTURAL STEEL SHALL CONFORM TO ASTM A572 GRADE 50 EXCEPT ANGLES, CHANNELS, PLATES, RODS, ETC SHALL CONFORM TO ASTM A36 AND STRUCTURAL TUBING SHALL CONFORM TO ASTM A500 GRADE B (Fy=46ksi).
- STRUCTURAL STEEL SHALL BE FABRICATED AND ERRECTED ACCORDING TO AISC 360-05, THIRTEENTH EDITION OF THE AISC MANUAL AND SPECIFICATIONS. CONTRACT DOCUMENTS SHALL GOVERN IN THE EVENT OF CONFLICT WITH THE AISC SPECIFICATION FOR THE DESIGN, FABRICATION, AND ERRECTION OF STRUCTURAL STEEL FOR BUILDINGS.

**MASONRY**

- MATERIAL AND WORKMANSHIP SHALL BE IN ACCORDANCE WITH ACI 530-II 'BUILDING CODE REQUIREMENTS FOR MASONRY STRUCTURES AND SPECIFICATION FOR MASONRY STRUCTURES'.
- MORTAR SHALL CONFORM TO ASTM C270 AND GROUT SHALL CONFORM TO ASTM C476, STANDARD SPECIFICATION FOR MORTAR AND GROUT FOR REINFORCED MASONRY.
- CONCRETE MASONRY UNITS SHALL BE GRADE N, IN ACCORDANCE WITH ASTM C90, STANDARD SPECIFICATIONS FOR HOLLOW LOAD-BEARING CONCRETE MASONRY UNITS.
- THE MINIMUM COMPRESSIVE STRENGTH OF MASONRY ASSEMBLIES AT 28 DAYS SHALL BE 1800 PSI ON THE NET SECTION (MORTAR BED AREA). (f<sub>m</sub> = 1500 PSI)

**MASONRY (CONT.)**

- ALL VERTICAL REINFORCING STEEL BARS IN CMU WALLS SHALL BE DOUELED TO THE CONCRETE FOUNDATION.
- ALL CMU REINFORCING STEEL BARS SHALL BE CONTINUOUS WITH LAP SPlice LENGTHS CONFORMING TO NOTE ABOVE.
- ALL OPENINGS IN CMU WALLS SHALL BE REINFORCED ON EACH SIDE AND TOP AND BOTTOM WITH A MINIMUM OF 1-#5 BAR.
- ALL CMU ELEMENTS SHALL BE ADEQUATELY BRACED TO PROVIDE STABILITY UNTIL THE ENTIRE STRUCTURE IS COMPLETE AND TO PREVENT DAMAGE DURING CONSTRUCTION, ESPECIALLY DUE TO BACKFILLING AND SOIL COMPACTION OPERATIONS.
- ALL VERTICAL REINFORCING SHALL BE CONTINUOUS THROUGH ALL WALL BEAMS AND SHALL BE ANCHORED IN BEAMS AT THE TOP OF WALLS.
- CONTINUOUS CONCRETE FILLED BLOCK BOND BEAMS SHALL BE PROVIDED AT THE TOP OF ALL WALLS. UNLESS OTHERWISE INDICATED BOND BEAM'S SHALL BE REINFORCED WITH 2-#5 CONTINUOUS.
- ALL MORTAR FOR BLOCK MASONRY SHALL BE TYPE S EXCEPT AS OTHERWISE NOTED.
- FILL ALL BLOCK CELLS WITH CONCRETE FROM TOP OF FOOTINGS TO FINISH FLOOR ELEVATION EXCEPT AS INDICATED OTHERWISE.
- PROVIDE CONTINUOUS HORIZONTAL NO. 3 GAGE TRUSS TYPE JOINT REINFORCING AT 16" O.C. IN ALL BLOCK MASONRY WALLS EXCEPT AS OTHERWISE NOTED.
- ALL MASONRY SHALL BE LAID IN RUNNING BOND UNLESS SPECIFICALLY NOTED OTHERWISE ON THE STRUCTURAL CONTRACT DRAWINGS. IF MASONRY BOND OTHER THAN RUNNING BOND IS UTILIZED, HORIZONTAL BOND BEAM'S SHALL BE CONSTRUCTED IN THE WALLS AT A MAXIMUM SPACING OF 48 INCHES ON CENTER.

**WOOD FRAMING**

- ALL WOOD FRAMING DESIGNED, DETAILED AND FABRICATED IN ACCORDANCE WITH THE LATEST EDITION OF THE 'NATIONAL DESIGN SPECIFICATION FOR WOOD CONSTRUCTION'.
- FOR STRUCTURAL LUMBER, PROVIDE THE FOLLOWING GRADE AND SPECIES:  
ALL STRUCTURAL LUMBER SHALL BE SOUTHERN YELLOW PINE NO. 2 GRADE OR BETTER (NO. 3 LUMBER WILL NOT BE ACCEPTED).

**DESIGN LOADS**

- WIND LOADING CRITERIA (PER ASCE 7-16)
 

BUILDING RISK CATEGORY	II
BASIC WIND SPEED: (VULT)	139 MPH
EXPOSURE CATEGORY:	C

**ERECTION BRACING AND FORMWORK**

- THE DESIGN, ADEQUACY AND SAFETY OF ERECTION BRACING, FORMWORK, SHORING, AND TEMPORARY SUPPORTS IS THE SOLE RESPONSIBILITY OF THE CONTRACTOR.
- ANCHOR BOLTS AND FOUNDATIONS HAVE NOT BEEN DESIGNED FOR ANY CONDITION OF LOADING OTHER THAN THAT OF THE COMPLETED STRUCTURE. VERIFICATION OF ADEQUACY OF ANCHOR BOLT AND FOUNDATIONS TO RESIST ERECTION INDUCED FORCES IS SOLELY THE RESPONSIBILITY OF THE STEEL ERECTOR AND CONTRACTOR.

**JOB SITE SAFETY**

THE GENERAL CONTRACTOR IS SOLELY RESPONSIBLE FOR JOB SITE SAFETY AND FOR CONFORMANCE WITH THE HEALTH AND SAFETY PROVISIONS REQUIRED BY ANY REGULATORY AGENCIES. THE STRUCTURAL ENGINEER OF RECORD HAS NO AUTHORITY TO EXERCISE ANY CONTROL OVER ANY CONSTRUCTION CONTRACTOR, OR THEIR EMPLOYEES WITH THEIR WORK OR ANY HEALTH OR SAFETY PRECAUTIONS.

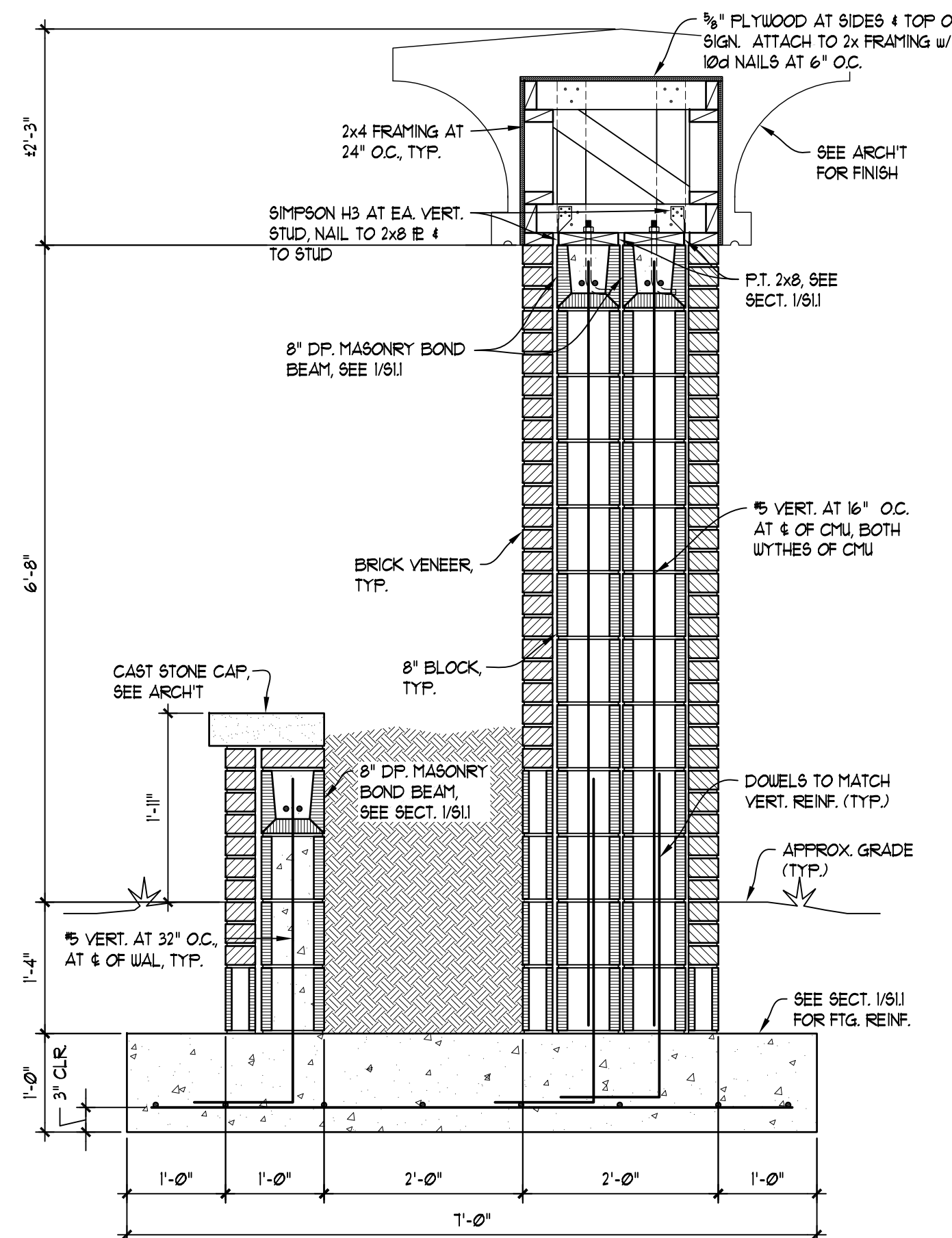

**SECTION 3**  
SCALE: 3/4"=1'-0"  
S11

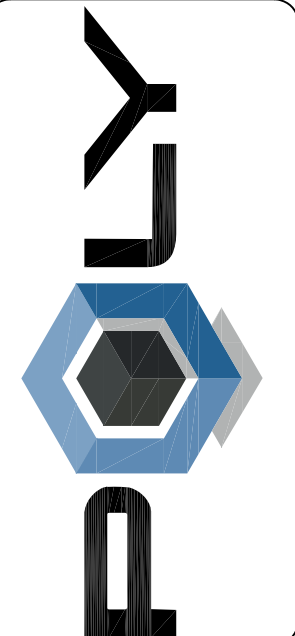

Revision	Date	Description

DATE: DECEMBER, 2018	DRAWN BY: PDL/TKJ	REGISTERED PROFESSIONAL ENGINEER	REGISTRATION No. AL PE #21832
DESIGNED BY: BBJ	ENG / ARCH / SURVEYOR OF RECORD: Bradley B. Johnson, PE	FL:	GA
1935 Headland Avenue Dothan, AL 36833	334-793-4700	ARCHITECT: CA0480	CA0201051011118
102 Sunset Lane Shalimar, FL 32579	2135 University Blvd, Ste. A Tusculoosa, AL 35401	ENGINEER: CA074E	CA01918 0011118
850-609-1100	205-752-4037	SURVEY: CA00184-3	03/29/27
WWW.POLY-INC.COM			

NEW GATEWAY AND WAYFINDING SIGNAGE THE CITY OF CRESTVIEW, FLORIDA	GATEWAY PLANTER SIGN FOUNDATION PLAN AND SECTIONS
--	--



BID DOCUMENTS

LIGHTING FIXTURE SCHEDULE									
MARK	MANUFACTURER	CATALOG NUMBER	LUMENS	WATTS	VOLTS	MOUNTING	RECESS	CONTROLS	REMARKS
A	STERNBERG	IW G74LED 5P 4L 40 TS MDL06 ARM=55 DBS	10475	98	120	SEE ARCH	NA	PE CELL	LED LANTERN
B	LITHONIA	DSXF1 LED P2 40K WFL MVOLT IS UBV DBBXD	5573	42	120	CONCRETE BASE SEE DETAIL	NA	PE CELL	LED FLOOD LIGHT

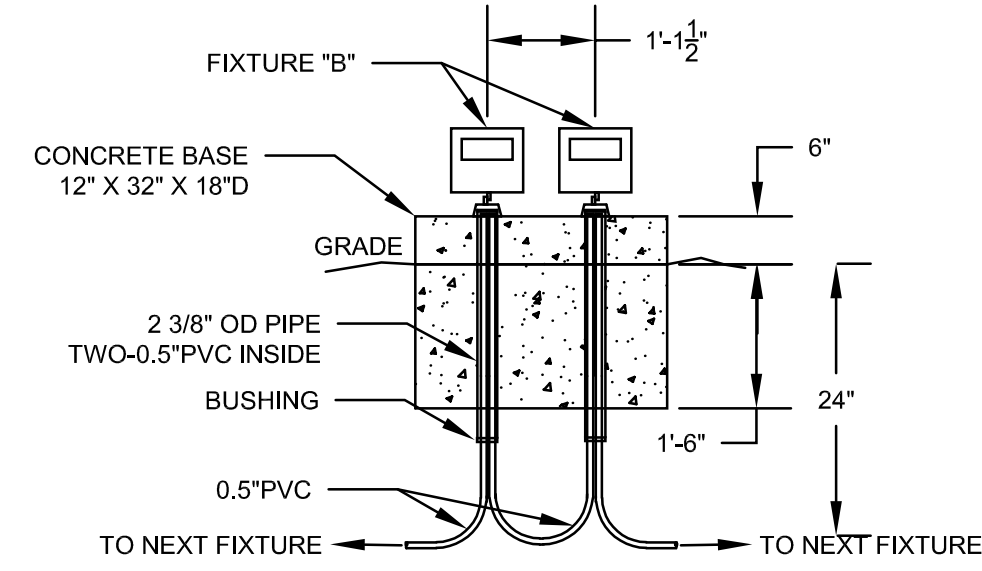

**"B" FIXTURE BASE MOUNTING**  
NTS

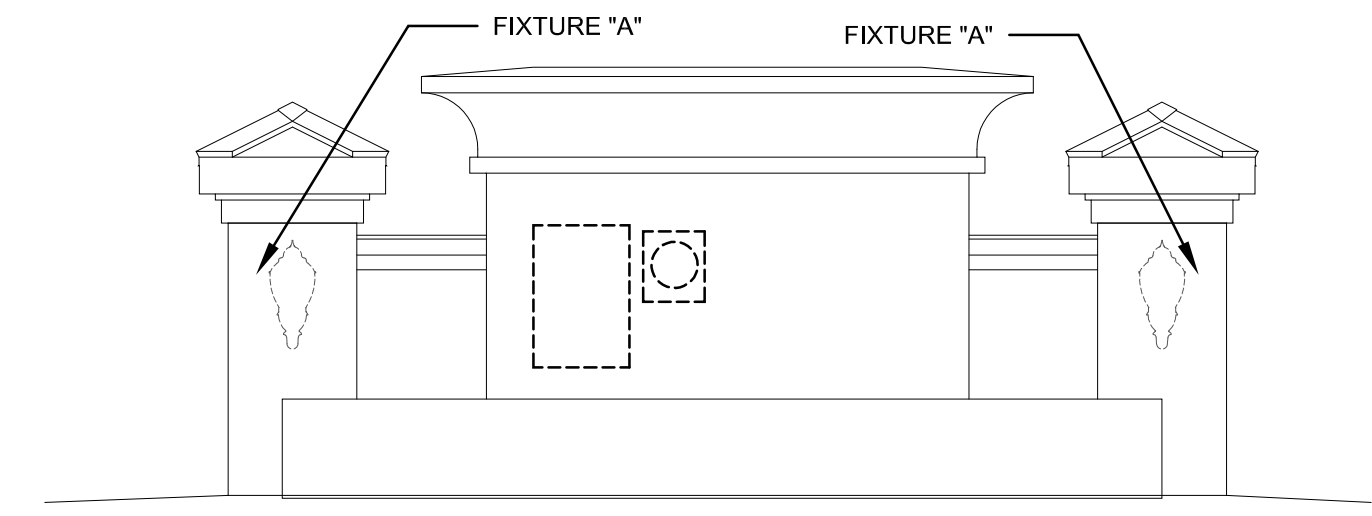

**ELEVATION PLAN - ELECTRICAL**  
1/4" = 10'

PANEL LPP		MINIMUM INTERRUPTING RATING 10000 AMPS					
60 AMP M/B		SURFACE MOUNT					
120 V, 1 PH, 3		NEMA-3R					
NOTES: SQ D NQ TYPE							
CKT NO	DESCRIPTION	BKR	VA	VA	BKR	DESCRIPTION	CKT NO
1	LTS	20/1	500		20/1	SPARE	2
3	SPARE	20/1				SPARE	4
5	SPARE	1PS			20/1	SPARE	6
7	SPACE	1PS			1PS	SPACE	8
9	REC	11PS			1PS	SPACE	10
			500 TOTAL VA				

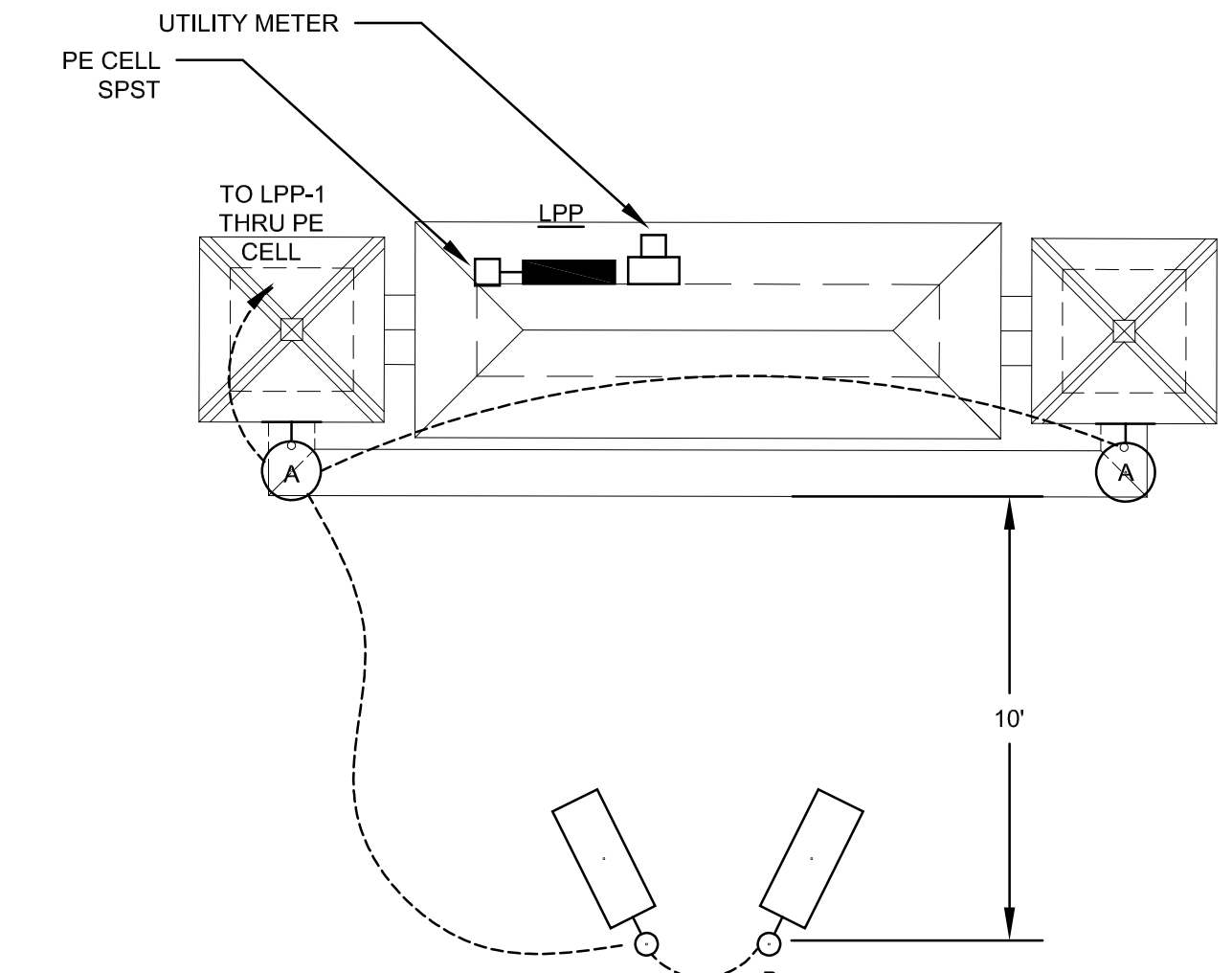

**PLAN VIEW - ELECTRICAL**  
1/4" = 10'

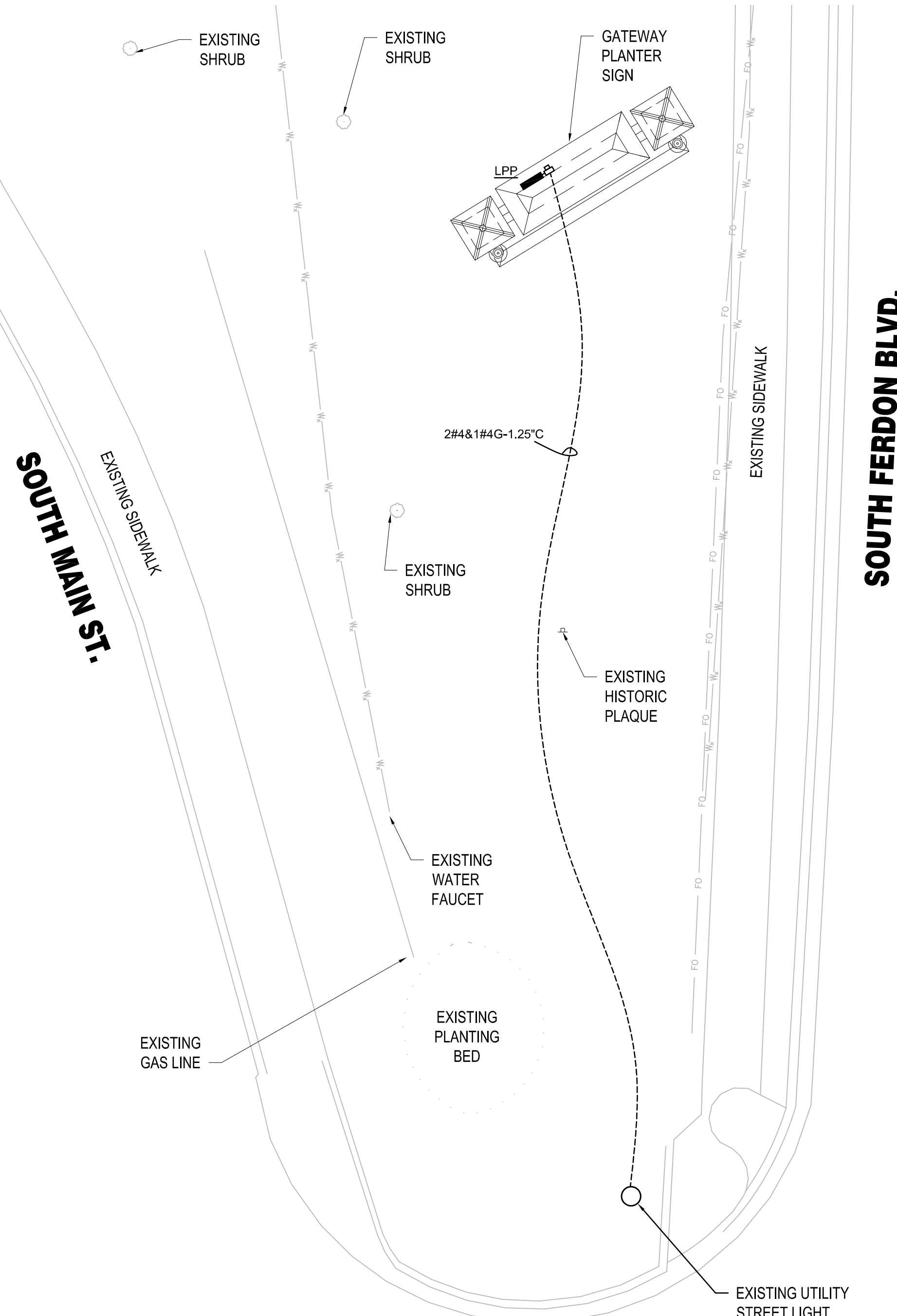

**ELECTRICAL SITE PLAN**  
1/8" = 10'

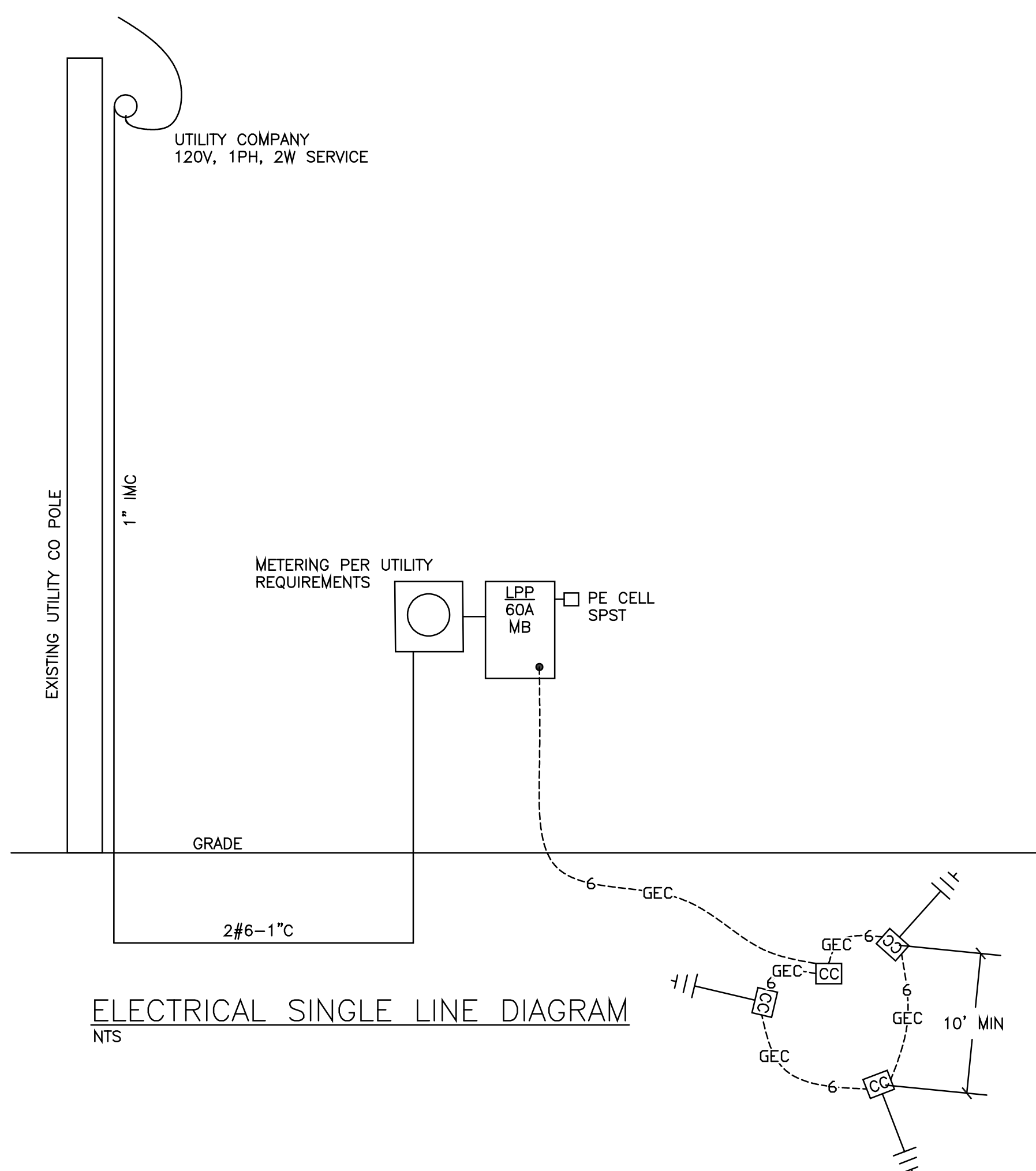

**ELECTRICAL SINGLE LINE DIAGRAM**  
NTS

**ELECTRICAL SPECIFICATIONS**

- FURNISH ALL LABOR AND MATERIALS REQUIRED TO COMPLETE THE ELECTRICAL WORK INDICATED ON DRAWINGS AND SPECIFIED BELOW.
- ALL WORK SHALL BE IN ACCORDANCE WITH THE NATIONAL ELECTRICAL CODE AND RULES AND REGULATIONS OF THE LOCAL BODIES HAVING JURISDICTION.
- ALL MATERIALS SHALL BE NEW AND LISTED BY UNDERWRITERS LABORATORIES AS CONFORMING TO THESE STANDARDS. ALL WORK SHALL BE EXECUTED IN A WORKMANLIKE MANNER AND SHALL PRESENT A NEAT AND MECHANICAL APPEARANCE WHEN COMPLETE.
- FURNISH AND INSTALL ALL ELECTRICAL LIGHTING FIXTURES AND OTHER DEVICES INDICATED ON THE DRAWINGS AND REQUIRED FOR A COMPLETE JOB. PROVIDE WIRING FOR ALL EQUIPMENT AND DEVICES. MAKE CONNECTIONS TO ALL EQUIPMENT SHOWN OR SPECIFIED.
- ALL CONDUIT CONCEALED, UNLESS SPECIFICALLY SHOWN EXPOSED. CONDUIT SYSTEMS TO BE ELECTRICALLY CONTINUOUS. USE DOUBLE LOCKNUTS AND BUSHINGS AT BOXES.
- CONDUCTORS SHALL HAVE CURRENT CARRYING CAPACITY PER N.E.C. AND 600 VOLT, THW, THWN, OR THHN INSULATION, #12 MINIMUM. MAKE ALL SPLICES AND CONNECTIONS MECHANICALLY AND ELECTRICALLY PERFECT. ALL CONDUCTORS SHALL BE COPPER. PROVIDE GREEN GROUNDING CONDUCTOR SIZED PER NEC IN ALL CIRCUITS.
- CONTRACTOR WILL CHECK ALL LIGHTING FIXTURES FOR EXACT TYPE MOUNTING AND SPACE REQUIRED BEFORE ROUGHING IN.
- SUPPORT OF ALL LIGHTING FIXTURES TO BE THE RESPONSIBILITY OF THIS CONTRACTOR.
- FOR BUILDING DETAILS, FOLLOW ARCHITECTURAL AND STRUCTURAL, AND FIT ELECTRICAL WORK THERETO.
- UPON COMPLETION, TEST ENTIRE WIRING SYSTEM AND SHOWN TO BE IN PERFECT WORKING ORDER IN ACCORDANCE WITH THE INTENT OF THESE DRAWINGS. PROMPTLY REPAIR, REPLACE OR OTHERWISE MAKE GOOD ANY DEFECT BECOMING APPARENT DURING THIS PERIOD AT NO COST TO THE OWNER.

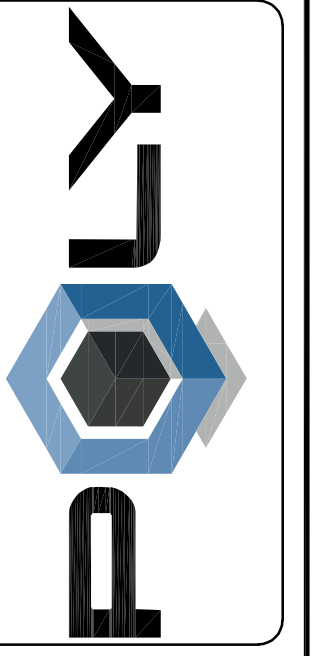

DATE:	DECEMBER 2018
DRAWN BY:	TVM
DESIGNED BY:	TVM
REGISTRATION No.:	
These drawings are the property of Poly, Inc. Any use, partial or full reproduction is prohibited except by written Agreement with Poly, Inc.	

**POLY, INC.**  
1032 Headfield Avenue  
Dunwoody, AL 35003  
334-799-4700

102 Summit Lane  
Shalimar, FL 32579  
850-698-1100

2135 University Blvd, Ste. A  
Tuscaloosa, AL 35401  
205-759-4937

WWW.POLY-INC.COM

NEW GATEWAY AND WAYFINDING SIGNAGE FOR THE CITY OF GRESTVIEW, FLORIDA

**ELECTRICAL PLANS**

SHEET No. E-1.0  
PROJECT No. 49-056

BID DOCUMENTS