

April 27, 2016

Geotechnical Engineering Report

Columbia Pike Multimodal Street Improvements Arlington, Virginia



**GeoConcepts
Engineering, Inc.**

19955 Highland Vista Drive, Suite 170
Ashburn, VA 20147

Phone 703 726 8030 • www.geoconcepts-eng.com

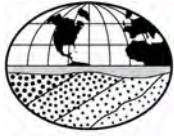

GeoConcepts Engineering, Inc.

19955 Highland Vista Dr., Suite 170
Ashburn, Virginia 20147
(703) 726-8030
www.geoconcepts-eng.com

April 27, 2016

Mr. Mike Albright
Kimley-Horn & Associates, Inc.
11400 Commerce Park Drive, Suite 400
Reston, Virginia 20191

**Subject: Geotechnical Engineering Report, Columbia Pike
Multimodal Street Improvements, Arlington, Virginia
(GeoConcepts Project No. 14189)**

Dear Mr. Albright:

GeoConcepts Engineering, Inc. (GeoConcepts) is pleased to present the following geotechnical engineering report prepared for Columbia Pike Multimodal Street Improvements in Arlington, Virginia.

We appreciate the opportunity to serve as your geotechnical consultant on this project. Please do not hesitate to contact me if you have any questions or want to meet to discuss the findings and recommendations contained in the report.

Sincerely,

GEOCONCEPTS ENGINEERING, INC.

Fernanda S. Madrona

Fernanda Madrona, EIT
Senior Staff Engineer
fmadrona@geoconcepts-eng.com

Table of Contents

1.0 Scope of Services	1
2.0 Site Description	1
3.0 Subsurface Conditions	1
3.1 Geology.....	1
3.2 Stratification	2
3.3 Groundwater	3
3.4 Soil Laboratory Test Results.....	3
3.4.1 Classification Test Results	3
3.4.2 Standard Proctor and California Bearing Ratio (CBR) Test Results.....	4
4.0 Engineering Analysis.....	4
4.1 Soil Design Parameters.....	5
4.2 Pavements.....	5
4.2.1 Traffic Analyses	5
4.2.2 Pavement Design Recommendations.....	6
4.3 Earthwork.....	8
4.3.1 Treatment of Unsuitable Pavement Subgrade Soils	9
5.0 General Limitations.....	9

Figure 1: Site Vicinity Map

Figure 2: Typical Edgedrain/Underdrain Details

Figure 3: Compacted Structural Fill Diagram

Appendix A: Subsurface Investigation

Appendix B: Soil Laboratory Test Results

Appendix C: Pavement Design Calculations

1.0 Scope of Services

This geotechnical engineering report presents the results of the field investigation, soil laboratory testing, and engineering analysis of the geotechnical data. This report specifically addresses the following:

- Recommended soil design parameters for the proposed site retaining walls.
- An assessment of subgrade conditions for support of flexible pavements, including recommended flexible pavement sections based on an estimated design California Bearing Ratio (CBR) value from soil laboratory test results and design traffic data by others.
- Earthwork recommendations for construction of loadbearing fills, including an assessment of on-site soils to be excavated for re-use as fill.

Services not specifically identified in the contract for this project are not included in the scope of services.

2.0 Site Description

Arlington County is planning multimodal street improvements along a 3.5-mile stretch of Columbia Pike from the Fairfax County line on the west end to South Joyce Street on the east end. Based on plans provided to us, the proposed construction consists of demolition and reconstruction of Columbia Pike in the following segments:

- Segment A: South Orme Street to about 200 feet east of South Oak Street, Stations 57+00 to 64+00.
- Segment C: South Courthouse Road to South Quinn Street, Stations 63+50 to 73+00.
- Segment D: South Garfield Street to South Courthouse Road, Stations 89+00 to 111+50.
- Segment F: South Wakefield Street to South Oakland Street, Stations 134+50 to 167+00.
- Segments H & I: South Jefferson Street to Four Mile Run, Stations 181+50 to 205+00.

In addition, proposed plans include site retaining walls, bicycle lanes, wider sidewalks, enhanced pedestrian crossings, landscaped median areas, and tree plantings.

3.0 Subsurface Conditions

Subsurface conditions were investigated by drilling a total of 60 test borings along the proposed roadway improvements and 14 test borings along the proposed site retaining wall areas. Test boring logs and boring location plans are presented in Appendix A of this report.

3.1 Geology

The site is located within the Coastal Plain Physiographic Province of Virginia. The Coastal Plain consists of a seaward thickening wedge of unconsolidated to semi-consolidated sedimentary deposits from the Cretaceous Geologic Period to the Holocene Geologic Epoch. These deposits represent marginal-marine to marine sediments consisting of interbedded sands and clays. The Coastal Plain is bordered to the east by the Atlantic Ocean and to the west by the Piedmont Physiographic Province. The dividing line between the Coastal Plain and the Piedmont is locally referred to as the "Fall Line". This name comes from the waterfalls that form as a result of the differential erosion that occurs as streams cross the Piedmont/Coastal Plain contact.

The existing fill soils of Stratum A are believed to be related to previous site grading. The natural soils assigned to Strata B, C, D, and E are believed to be Alluvial deposits of Quaternary age, Pleistocene age terrace deposits, Potomac Group sedimentary deposits, and residual sediments derived from early Paleozoic bedrock.

The Alluvial and Terrace Deposits are granular units dominated by gravels, sands, and silts, with lesser amounts of clay distributed heterogeneously. The Alluvial materials are gray to gray-brown, and poorly stratified, while the Terrace Deposits are more highly oxidized showing lighter colors ranging from light gray to yellow and red. The Terrace Deposits tend to be more stratified than the more recent Alluvial deposits.

The Potomac Group sediments are the oldest sedimentary deposits in the Washington, DC area, and date from the Early Cretaceous Period. These sediments are known to be highly over-consolidated as a result of the weight of a substantial thickness of overlying soils that have since been eroded away.

The bedrock underlying the site is mapped as the Indian Run Formation of the Cambrian geologic period.

3.2 Stratification

The subsurface materials encountered have been stratified for purposes of our discussions herein. These stratum designations do not imply that the materials encountered are continuous across the site. Stratum designations have been established to characterize similar subsurface conditions based on material gradations and parent geology. The subsurface materials encountered in the test borings completed at the site have been assigned to the following strata:

Stratum A (Existing Fill)	loose to very dense or soft to very stiff, POORLY GRADED SAND (SP) with gravel, clayey SAND (SC), LEAN CLAY (CL) and FAT CLAY (CH) with various amounts of sand, moist, brown, orange-brown, and gray-brown
Stratum B (Alluvial)	medium dense to very dense or stiff to very stiff, clayey SAND (SC) with gravel, LEAN CLAY (CL) and FAT CLAY (CH) with various amounts of sand, moist to wet, brown, orange-brown, and gray
Stratum C1 (Terrace Deposits)	firm to hard, LEAN CLAY (CL) and FAT CLAY (CH), with various amounts of sand, moist, gray, brown, and orange-brown
Stratum C2 (Terrace Deposits)	very loose to very dense, POORLY GRADED SAND (SP), clayey SAND (SC), and POORLY GRADED GRAVEL (GP), moist to wet, orange-brown, red, brown and white
Stratum D1 (Potomac Group)	soft to very stiff, LEAN CLAY (CL) and FAT CLAY (CH) with various amounts of sand, moist, brown, orange-brown, and gray
Stratum D2 (Potomac Group)	loose to very dense, silty SAND (SM), clayey SAND (SC), and POORLY GRADED SAND (SP), moist to wet, brown, black, orange-brown, white
Stratum E1 (Residual)	loose to very dense or stiff to very hard, silty SAND (SM), clayey SAND (SC), and sandy SILT (ML), micaceous, moist, gray, orange –brown
Stratum E2 (Intermediate Geomaterial, IGM)	very dense, silty SAND (SM), moist, gray

The two letter designations included in the strata descriptions presented above and on the test boring logs represent the Unified Soil Classification System (USCS) group symbol and group name for the samples based on laboratory testing per ASTM D-2487 and visual classifications per ASTM D-2488. It should be noted that visual classifications per ASTM D-2488 may not match classifications determined by laboratory testing per ASTM D-2487.

3.3 Groundwater

Groundwater level observations were made in the field during drilling. Groundwater was encountered at six boreholes during drilling, and a summary of the water level readings rounded off to the nearest 0.5 feet depth is presented below in Table 3.3-1.

Table 3.3-1: Groundwater Summary

Test Boring No.	Depth to Groundwater (feet)
AB-12	28.5
CRW-1	14.0
CB-9	8.0
FRW-1	9.0
FRW-8	5.5
IRW-4A	13.0

The groundwater observations presented herein are considered to be an indication of the groundwater levels at the dates and times indicated. Where more impervious Strata B, C1, and D1 clay soils are encountered, the amount of water seepage into the borings is limited, and it is generally not possible to establish the location of the groundwater table through short term water level observations. Accordingly, the groundwater information presented herein should be used with caution. Also, fluctuations in groundwater levels should be expected with seasons of the year, construction activity, changes to surface grades, precipitation, or other similar factors.

3.4 Soil Laboratory Test Results

Selected soil samples obtained from the field investigation were tested for grain size distribution, Atterberg limits, compaction characteristics using standard effort, California Bearing Ratio (CBR), and natural moisture contents. A summary of soil laboratory test results is presented below, and the results of natural moisture content tests are presented on the test boring logs in Appendix A.

3.4.1 Classification Test Results

Maximum and minimum values of percent fines passing the US Standard No. 200 sieve, liquid limits, and plasticity indices for each stratum are presented below in Table 3.4.1-1. A detailed summary of soil classification test results is presented in Table B-1 in Appendix B.

Table 3.4.1-1: Classification Test Results Summary

Stratum	Range of % Passing #200 Sieve	Range of Liquid Limit (LL)	Range of Plasticity Index (PI)
Stratum A (Existing Fill)	22-45	32-48	16-26
Stratum B (Alluvial)	51	36	17
Stratum C1 (Terrace Deposits)	59-87	21-51	4-30

Stratum	Range of % Passing #200 Sieve	Range of Liquid Limit (LL)	Range of Plasticity Index (PI)
Stratum C2 (Terrace Deposits)	9-44	27-30	12-16
Stratum D1 (Potomac Group)	51-94	53-71	33-44
Stratum D2 (Potomac Group)	29-32	44-74	29-54
Stratum E1 (Residual)	21	53	20

3.4.2 Standard Proctor and California Bearing Ratio (CBR) Test Results

A total of 14 standard proctor tests (VTM-1) and CBR tests (VTM-8) were performed on bulk samples collected from the test borings. A summary of standard proctor and CBR test results is presented below in Table 3.4.2-1. Individual sample results are presented in Appendix B.

Table 3.4.2-1: Standard Proctor and CBR Test Results Summary

Test Boring No.	Sample Depth (ft)	Stratum	USCS/AASHTO Symbol	Maximum Dry Density (pcf)	Optimum Moisture Content (%)	Max. Swell (%)	CBR Value* (%)
AB-12	0.0-5.0	A	SC/A-2-7	123	12	0.2	12.1
AB-15	0.0-5.0	A/C2	SC/A-2-6	127	9	0.2	13.7
CRW-2	0.0-5.0	A	SC/A-6	121	13	0.3	4.7
CB-5	0.0-5.0	C1	CL/A-7-6	124	11	2.4	2.1
CB-8	0.0-5.0	C2	SC/A-6	113	15	0.9	1.6
DB-2	0.0-5.0	C1	CH/A-7-6	127	9	5.4	2.5
DB-6	0.0-5.0	C2	SC/A-2-6	129	8	0.8	9.0
DB-10	0.0-5.0	C2	SC/A-6	124	10	0.2	16.0
FB-2	0.0-5.0	D2	SC/A-2-7	131	9	0.1	9.9
FB-9	0.0-5.0	B	CL/A-6	115	14	2.5	4.3
FB-18	0.0-5.0	C1	CL/A-4	97	25	5.1	2.3
HB-5	0.0-5.0	D2	SC/A-2-7	115	13	1.2	8.0
IB-2	0.0-5.0	D1	CH/A-7-6	112	15	3.8	4.3
IB-9	0.0-5.0	D2	SC/A-2-7	129	9	1.6	8.8

* CBR values correspond to 0.1-inch penetration, performed on a sample compacted to 95% compaction.

4.0 Engineering Analysis

Recommendations regarding soil design parameters, pavements, and earthwork are presented herein.

4.1 Soil Design Parameters

Recommended soil design parameters to be used for this project are presented in Table 4.1-1 herein.

Table 4.1-1: Recommended Soil Design Parameters

Stratum	Total Unit Weight (pcf)	Angle of Internal Friction (degrees)	Lateral Earth Pressure Coefficients			Coefficient of Sliding Friction
			Active (Ka)	At-Rest (Ko)	Passive (Kp)	
Stratum A (Existing Fill)	125	30	0.33	0.50	3.00	0.35
Stratum B (Alluvial)	120	28	0.36	0.53	2.77	0.35
Stratum C1 (Terrace Deposits)	120	28	0.36	0.53	2.77	0.30
Stratum C2 (Terrace Deposits)	125	32	0.31	0.47	3.25	0.40
Stratum D1 (Potomac Group)	120	20	0.49	0.66	2.04	0.30
Stratum D2 (Potomac Group)	125	34	0.28	0.44	3.54	0.40
Stratum E1 (Residual)	125	30	0.33	0.50	3.00	0.35
Stratum E2 (IGM)	130	38	0.24	0.38	4.20	0.50

4.2 Pavements

Pavement subgrades are expected to consist of existing fill, natural soils, or new compacted fill. These materials are generally considered suitable for support of the planned roadways. However, where pavement subgrades consist of unsuitable soils (soft or loose soils with a SPT blow count less than 5, soils classified as CH, MH, OH and OL in accordance with the Unified Soil Classification System (USCS), and soils with a CBR value less than 5), we recommend undercutting the unsuitable soil to a depth of at least 3 feet and backfilling with new compacted fill with a minimum CBR value of 5 in accordance with Section 303.04(b) paragraph 5 of the VDOT Road and Bridge Specifications. Recommendations regarding new compacted fill are presented in Section 4.3 of this report, and specific locations where unsuitable soils are expected along the proposed roadways are presented in Section 4.3.1 of this report.

4.2.1 Traffic Analyses

A pavement design was performed using the traffic data and information provided in the Columbia Pike Multimodal Street Improvements Transportation Study dated June 2012. Columbia Pike is classified as an undivided primary route. The proposed pavement will have 10 to 11 feet wide lanes in each direction. We have used the traffic data summary presented in Table 4.2.1-1 for pavement section design.

Table 4.2.1-1: Design Values for Pavement Section Design

Design Parameter	Flexible Pavement Design Value		Rigid Pavement Design Value	
	Segments A, C, D, and F	Segments H and I	Segments A, C, D, and F	Segments H and I
Highway Classification	Undivided Primary Route ⁽¹⁾		Undivided Primary Route ⁽¹⁾	
Design Years	20 ⁽¹⁾		30 ⁽¹⁾	
Two Way ADT (2018)	31,525 ⁽²⁾	31,955 ⁽²⁾	31,525 ⁽²⁾	31,955 ⁽²⁾

Design Parameter	Flexible Pavement Design Value		Rigid Pavement Design Value	
	Segments A, C, D, and F	Segments H and I	Segments A, C, D, and F	Segments H and I
Percent Trucks (Class 5 or Greater)	5 ⁽³⁾		5 ⁽³⁾	
Traffic Growth Rate (%)	0.21 ⁽¹⁾	0.38 ⁽¹⁾	0.21 ⁽¹⁾	0.38 ⁽¹⁾
Number of Lanes in Design Direction	2 ⁽¹⁾		2 ⁽¹⁾	
Lane Distribution Factor	90 ⁽⁴⁾		90 ⁽⁴⁾	
Average Initial Truck Factor (ESALs/Truck)	1.05 ⁽⁴⁾		1.59 ⁽⁴⁾	
Obtained ESALs based on the data above	5,550,524	5,718,512	12,741,724	13,241,836

Notes:

⁽¹⁾ From Multimodal Street Improvements Transportation Study dated June 2012

⁽²⁾ Estimated from the information provided

⁽³⁾ Assumed for design

⁽⁴⁾ Values from VDOT Pavement Design Standards

4.2.2 Pavement Design Recommendations

Pavement sections were designed according to the 1993 AASHTO Guide for Design of Pavement Structures taking into consideration the laboratory tests results from 14 California Bearing Ratio (CBR) tests performed under this contract. Table 4.2.2-1 below presents the average California Bearing Ratio (CBR) test results and the recommended design CBR value for each section. Design roadbed soil resilient modulus and mean effective K-value used for the pavement design are also presented in Table 4.2.2-1.

Table 4.2.2-1: Recommended Pavement Subgrade Design Parameters

Roadway	Average CBR	2/3 of Average CBR	Design CBR used for Pavement Design ⁽¹⁾	Soil Resilient Modulus (psi) ⁽²⁾	Mean Effective K-value (psi/inch) ⁽³⁾
Segment A	12.9	8.6	3.33	5,000	257
Segment C	2.8	1.9 ⁽⁴⁾			
Segment D	9.2	6.1			
Segment F	5.5	3.7			
Segment H/I	7.0	4.7			

Notes:

⁽¹⁾ Design CBR for Pavement Design = $5 \times 2/3 = 3.33$

⁽²⁾ Soil Resilient Modulus = $1500 \times \text{CBR}$

⁽³⁾ Mean effective K-value (k-value) = $M_r/19.4$, max 500 psi/inch

⁽⁴⁾ Undercut and replacement of soils with $\text{CBR} > 5$ is recommended per Section 4.3.1 of this report

If fill placed at the site is generated from off-site borrow areas, the actual CBR value for the pavement subgrades may be significantly different from the value presented herein. Therefore, CBR tests should be performed on the in-place subgrade after rough grading and installation of utilities within roadways. Final pavement sections should be based on CBR tests taken on subgrade soils at the time of construction.

Additional pavement design parameters used for the flexible pavement and rigid pavement design are presented in Table 4.2.2-2 herein.

Table 4.2.2-2: Pavement Design Parameters

Design Parameter	Flexible Pavement Design Value	Rigid Pavement Design Value
Initial Serviceability	4.2	4.5
Terminal Serviceability	2.8	2.8
Standard Deviation	0.49	0.39
Reliability	90%	90%

Based on the estimated design CBR, resilient modulus value, and traffic loading, the following flexible and rigid pavement sections are recommended below in Table 4.2.2-3. Pavement design calculations are presented in Appendix C of this report.

Table 4.2.2-3: Recommended Pavement Sections

Roadway	Segments A, C, D, and F	Segments H and I
Flexible Pavement Layer	Thickness (inches)	
SM-9.5	2.0	2.0
BM-25.0	8.0	8.0
Aggregate Base Material Type I, No. 21A	12.0	12.0
Rigid Pavement Layer	Thickness (inches)	
JPCP	10	10
Aggregate Base Material Type I, No. 21A	6	6
Minimum Percent Steel Reinforcement Required	0.1 (WWF placed at mid-depth of the concrete)	
Dowel Requirements	1-inch diameter smooth dowel along transverse joints, 18-inch in length, 12-inch O.C., placed at mid-height of concrete. Epoxy-coated rebar is recommended to prevent corrosion.	

Proper drainage is imperative in the design and construction of flexible pavements. The aggregate base material, Type I, size No. 21A should be connected to a longitudinal pavement drain (UD-4) with outlets or is daylighted to provide for positive lateral drainage. Depending on the bridge profile, a transverse cross-drain (CD-2) may also be placed at the bridge approaches. Typical edgedrain/underdrain details are presented as figure 2 at the end of this report. The roadway shoulder or adjacent ground should be graded so that surface drainage runs away from the pavement and does not stand on the pavement's edge. The overall pavement design should also include suitable storm inlets and diversion structures for collecting surface runoff and to limit excessive ponding on paved surfaces.

Construction loading conditions may be more severe than post-construction conditions and typically occurs prior to placement of the total pavement sections. Construction traffic activity on partially constructed pavement sections may result in subgrade and pavement failures due to the reduced support qualities of a partial section and the relatively heavy loads associated with construction traffic. Accordingly,

consideration should be given to the construction of designated haul roads where the thickness of the granular subbase and/or asphalt base course has been increased to account for the heavier-loaded construction traffic. We suggest that placement of the asphalt surface course not occur until all the major construction has been completed for pavement areas subjected to construction traffic.

4.3 Earthwork

Fill may be required for site grading in pavement areas and as backfill against retaining walls. Unsuitable existing fill, soft or loose natural soils, organic material, and rubble should be stripped to approved subgrades as determined by the geotechnical engineer. Asphalt, crushed stone, and concrete depths presented on the boring logs should not be considered as stripping depths, as stripping depths may vary widely across the site. Stripping depths will probably extend to greater depths due to the presence of minor amounts of organics, roots, and other surficial materials that will require removal as a part of the stripping operations. In addition, seasonal soil moisture variations can affect stripping depths. In general, less stripping may occur during summer months when drier weather conditions can be expected. The depth of required stripping should be determined prior to construction by the excavation contractor using test pits, probes, or other means that the contractor wishes to employ, and this determination should be the responsibility of the excavation contractor. All subgrades should be proofrolled with a minimum 20 ton, loaded dump truck or suitable rubber tire construction equipment approved by the geotechnical engineer, prior to the placement of new fill.

For pavement areas, the new fill should extend at least 2 feet outside pavement edges, as illustrated by Figure 3 at the end of this report. Fill material should be placed in lifts not exceeding 8 inches loose thickness, with fill materials compacted by hand operated tampers or light compaction equipment placed in maximum 4-inch thick loose lifts. Fill should be compacted at +/- 2% of the optimum moisture content to at least 95 percent of the maximum dry density per VTM-1. The upper 6 inches of pavement subgrades should be compacted to at least 100 percent of the maximum dry density per the same standard.

Materials used for compacted fill should consist of soils classifying SC, SM, SP, SW, GC, GM, GP, or GW per ASTM D-2487, with a maximum dry density greater than 105 pcf. Materials used for backfill against walls below grade should consist of soils classifying SM, SP, SW, GM, GP, or GW, with a liquid limit and plasticity index less than 40 and 15, respectively. It is expected that portions of the soils excavated at the site will be suitable for re-use as fill based on classification. However, the Stratum A existing fill may not be suitable for re-use as new compacted fill due to deleterious man-made materials in the fill. In addition, drying of excavated soils by spreading and aerating may be necessary to obtain proper compaction. This may not be practical during the wet period of the year. Accordingly, earthwork operations should be planned for early Spring through late Fall, when drier weather conditions can be expected. Individual borrow areas, both from on-site and off-site sources, should be sampled and tested to verify classification of materials prior to their use as fill.

Fill materials should not be placed on frozen or frost-heaved soils, and/or soils that have been recently subjected to precipitation. All frozen or frost-heaved soils should be removed prior to continuation of fill operations. Borrow fill materials should not contain frozen materials at the time of placement.

Compaction equipment that is compatible with the soil type used for fill should be selected. Theoretically, any equipment type can be used as long as the required density is achieved; however, sheepsfoot roller equipment are best suited for fine-grained soils and vibratory smooth drum rollers are best suited for granular soils. Ideally, a smooth drum roller should be used for sealing the surface soils at the end of the day or prior to upcoming rain events. In addition, compaction equipment used adjacent to walls below grade should be selected so as to not impose undesirable surcharge on walls. All areas receiving fill should be graded to facilitate positive drainage of any water associated with precipitation and surface run-off.

For utility excavation backfill, we recommend that open graded stone be used to backfill the pipe trench to the spring line of the pipe. Backfill should be compacted in lifts not exceeding 6 inches loose thickness, to at least 95 percent of the maximum dry density per VTM-1. Hand operated compaction equipment should

be used until the backfill has reached a level 1 foot above the top of the pipe to prevent damaging the pipe. Also, backfill material within 2 feet of the top of the pipe should not contain rock fragments or gravel greater than 1-inch in diameter.

After completion of compacted fill operations in retaining wall or pavement areas, construction of building elements or asphalt should begin immediately, or the finished subgrade should be protected from exposure to inclement weather conditions. Exposure to precipitation and freeze/thaw cycles will cause the finished subgrade to soften and become excessively disturbed. If development plans require that finished subgrades remain exposed to weather conditions after completion of fill operations, additional fill should be placed above finished grades to protect the newly placed fill. Alternatively, a budget should be established for reworking of the upper 1 to 2 feet of previously placed compacted fill.

4.3.1 Treatment of Unsuitable Pavement Subgrade Soils

The majority of on-site soils are suitable as pavement subgrade materials. However, soft or loose soils with a SPT blow count less than 5, soils classified as CH, MH, OH and OL in accordance with the Unified Soil Classification System (USCS), and soils with a CBR value less than 5 are not considered suitable for direct support of the proposed roadway. Removal and replacement of these unsuitable soils are recommended to limit potential total and differential settlement of pavements and structures. Table C-1 in Appendix C presents specific locations where unsuitable soils were encountered along the project alignment. In areas where no treatment is required, subgrade soils shall be dried or wetted to attain an appropriate range of moisture content for compaction purposes, prior to placement of aggregate base course.

5.0 General Limitations

Recommendations contained in this report are based upon the data obtained from the relatively limited number of test borings. This report does not reflect conditions that may occur between the points investigated, or between sampling intervals in test borings. The nature and extent of variations between test borings and sampling intervals may not become evident until the course of construction. Therefore, it is essential that on-site observations of subgrade conditions be performed during the construction period to determine if re-evaluation of the recommendations in this report must be made. It is critical to the successful completion of this project that GeoConcepts be retained during construction to observe the implementation of the recommendations provided herein.

This report has been prepared to aid in the evaluation of the site and to assist your office and the design professionals in the design of this project. It is intended for use with regard to the specific project as described herein. Changes in proposed construction, grading plans, etc. should be brought to our attention so that we may determine any effect on the recommendations presented herein.

An allowance should be established for additional costs that may be required for foundation and earthwork construction as recommended in this report. Additional costs may be incurred for various reasons including wet fill materials, soft subgrade conditions, unexpected groundwater problems, rock excavation, etc.

This report should be made available to bidders prior to submitting their proposals to supply them with facts relative to the subsurface conditions revealed by our investigation and the results of analyses and studies that have been performed for this project. In addition, this report should be given to the successful contractor and subcontractors for their information only.

We recommend the project specifications contain the following statement: "A geotechnical engineering report has been prepared for this project by GeoConcepts Engineering, Inc. This report is for informational purposes only and should not be considered part of the contract documents. The opinions expressed in this report are those of the geotechnical engineer and represent their interpretation of the subsoil conditions, tests and results of analyses that they performed. Should the data contained in this report not be adequate for the contractor's purposes, the contractor may make their own investigations, tests and analyses prior to bidding."

This report was prepared in accordance with generally accepted geotechnical engineering practices. No warranties, expressed or implied, are made as to the professional services included in this report.

We appreciate the opportunity to be of service for this project. Please contact the undersigned if you require clarification of any aspect of this report.

Sincerely,

GEOCONCEPTS ENGINEERING, INC.

Fernanda S. Madrona

Fernanda Madrona, EIT
Senior Staff Engineer

Paul E. Burkart, PE
Principal



MS/FM/SU/PEB/shm

N:\PROJECTS\Active 14 Projects\14189, Columbia Pike\Final\Columbia Pike Multimodal Street Improvements Geotechnical Report.docx

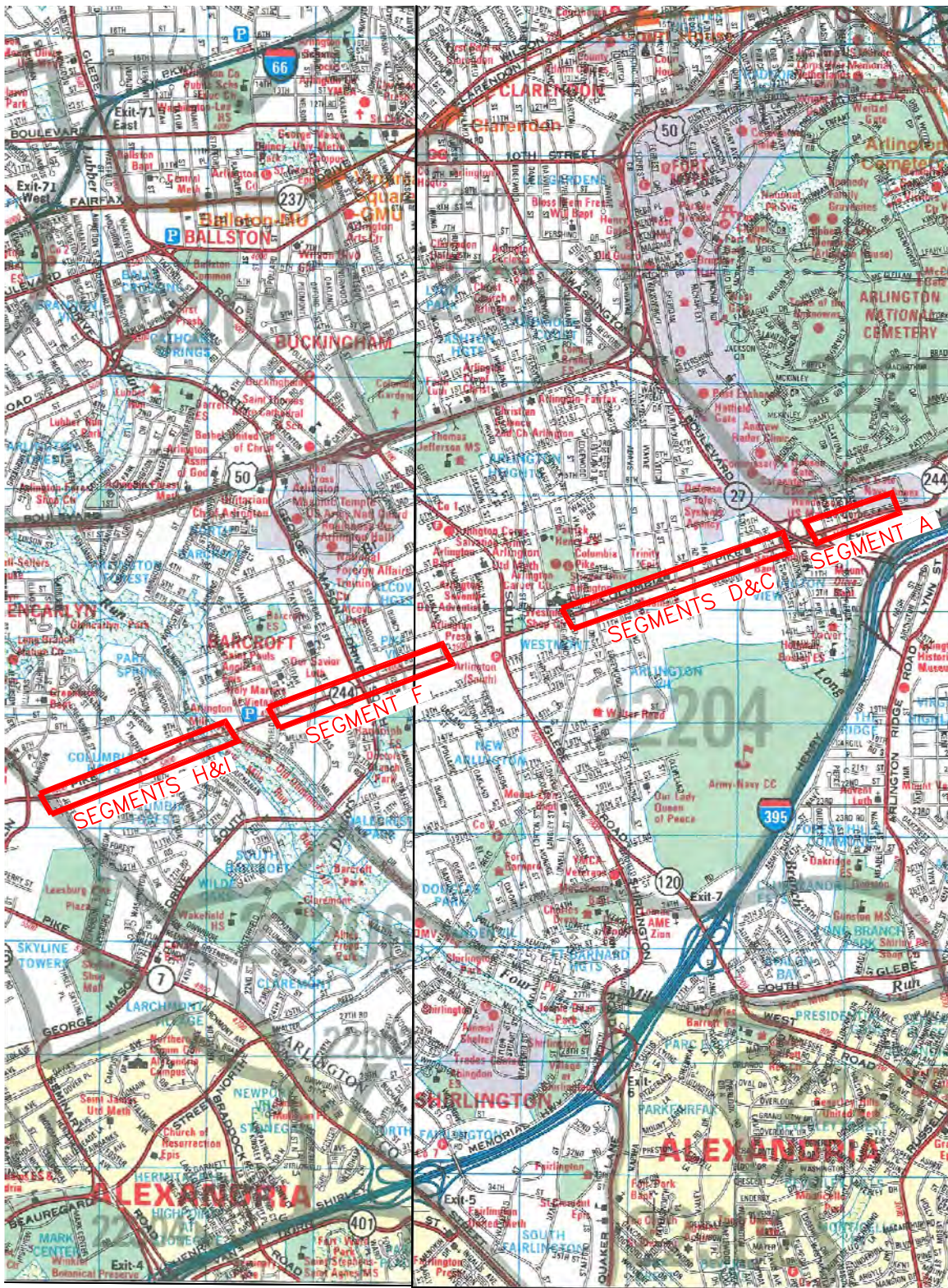

COPYRIGHT ADC THE MAP PEOPLE, PERMITTED USE 20200754



**GeoConcepts
Engineering, Inc.**

19955 Highland Vista Dr., Suite 170 (703) 726-8030
Ashburn, Virginia 20147 (703) 726-8032 fax

COLUMBIA PIKE MULTIMODAL STREET IMPROVEMENTS
ARLINGTON COUNTY, VIRGINIA

SITE VICINITY MAP

Scale:
N.T.S.

Fig.

Date:
APRIL 2016

Drawn By:
F.S.M.

Checked By:
P.E.B.

Project No.:
14189

1

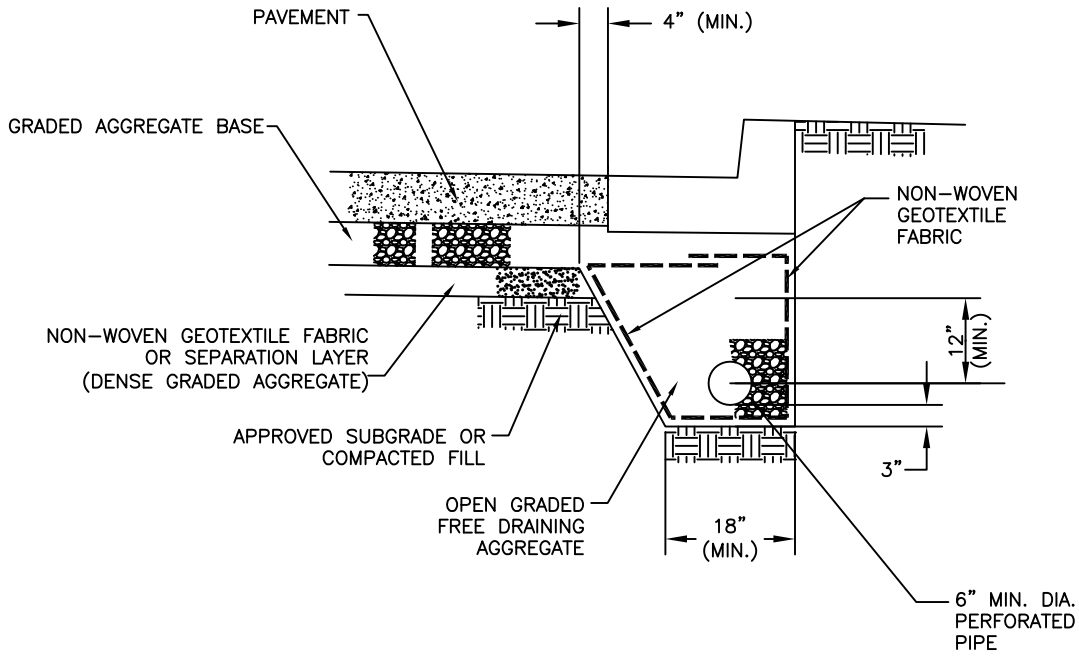

TYPICAL SHOULDER EDGEDRAIN DETAIL

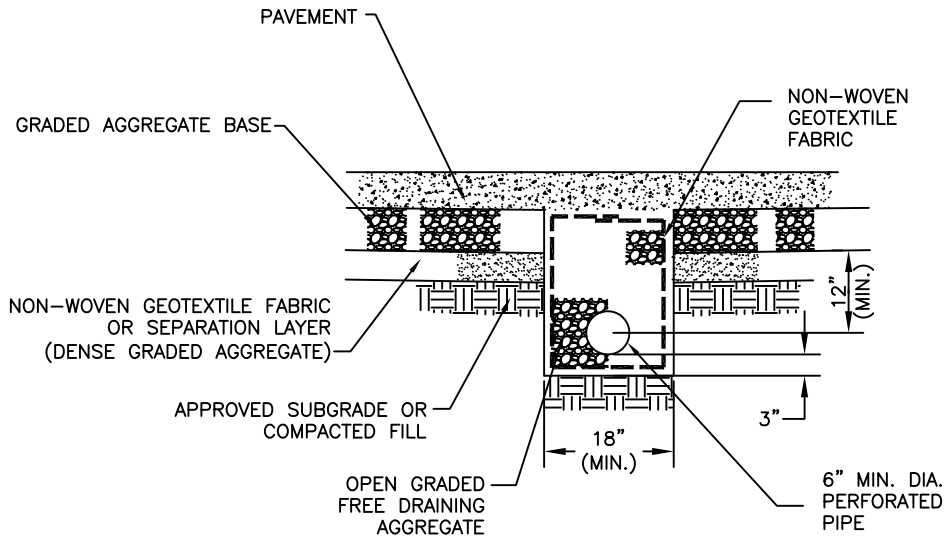

TYPICAL INTERIOR UNDERDRAIN DETAIL



**GeoConcepts
Engineering, Inc.**

19955 Highland Vista Dr., Suite 170 (703) 726-8030
Ashburn, Virginia 20147 (703) 726-8032 fax

COLUMBIA PIKE MULTIMODAL STREET IMPROVEMENTS
ARLINGTON COUNTY, VIRGINIA

TYPICAL EDGEDRAIN/UNDERDRAIN
DETAILS

Scale:
N.T.S.

Fig.

Date:
APRIL 2016

Drawn By:
F.S.M.

Checked By:
P.E.B.

Project No.:
14189

2

N:\PROJECTS\Active 14 Projects\14189, Columbia Pike\CAD\CSF DIAGRAM (PAVEMENT curb and gutter) 2-31-08.dwg

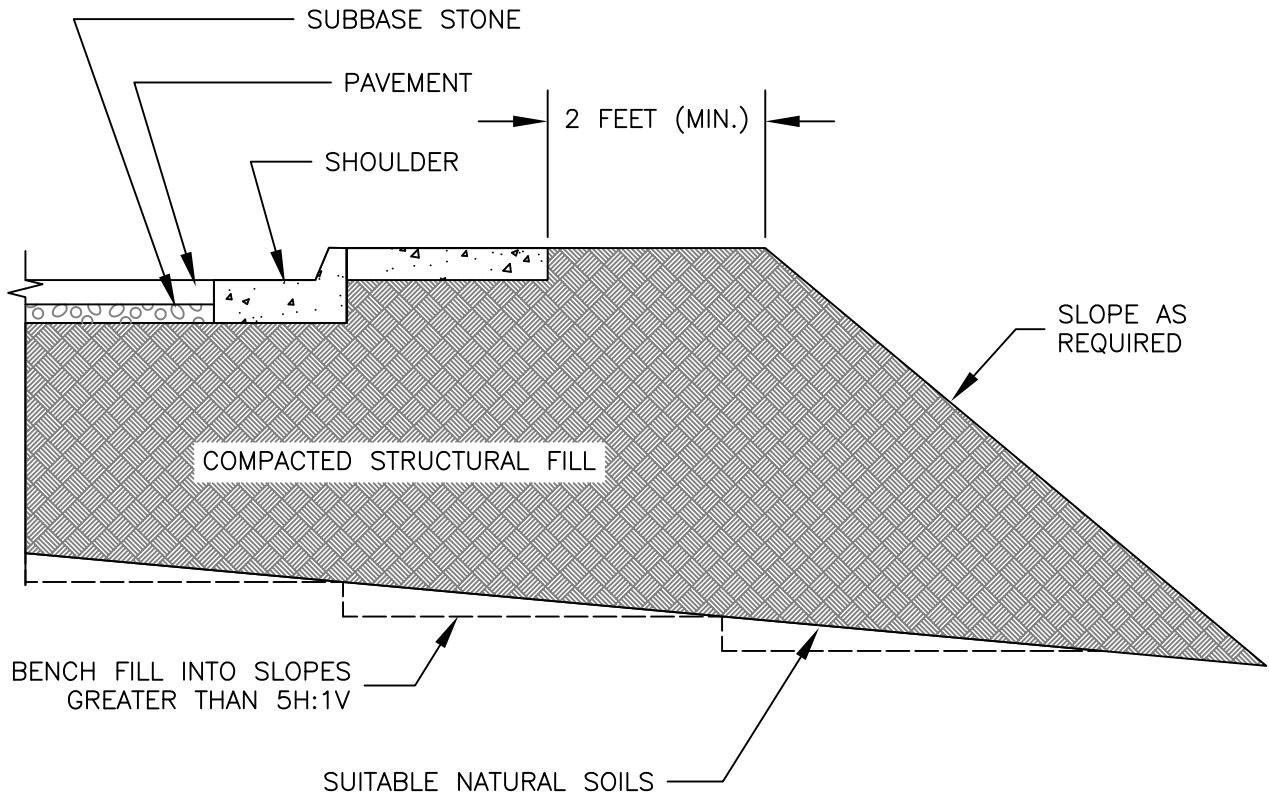

**GeoConcepts
Engineering, Inc.**

19955 Highland Vista Dr., Suite 170 (703) 726-8030
Ashburn, Virginia 20147 (703) 726-8032 fax

COLUMBIA PIKE MULTIMODAL STREET IMPROVEMENTS
ARLINGTON COUNTY, VIRGINIA

COMPACTED STRUCTURAL
FILL DIAGRAM

Scale:
N.T.S.

Fig.

Date:
APRIL 2016

Drawn By:
F.S.M.

Checked By:
P.E.B.

Project No.:
14189

3

Appendix A

Subsurface Investigation

Subsurface Investigation Procedures (1 page)

Identification of Soil (1 page)

Test Boring Notes (1 page)

Hand Auger Boring Notes (1 page)

Test Boring Logs (75 pages)

Pavement Core Photographs (61 pages)

Boring Location Plans, Figures A.1 through A.11 (11 pages)

Subsurface Investigation Procedures

1. Test Borings – Hollow Stem Augers

The borings are advanced by turning an auger with a center opening of 2-¼ inches. A plug device blocks off the center opening while augers are advanced. Cuttings are brought to the surface by the auger flights. Sampling is performed through the center opening in the hollow stem auger, by standard methods, after removal of the plug. Usually, no water is introduced into the boring using this procedure.

2. Standard Penetration Tests

Standard penetration tests are performed by driving a 2 inch O.D., 1-¾ inch I.D. sampling spoon with a 140-pound hammer falling 30 inches, according to ASTM D-1586. After an initial 6 inches penetration to assure the sampling spoon is in undisturbed material, the number of blows required to drive the sampler an additional 12 inches is generally taken as the N value. In the event 30 or more blows are required to drive the sampling spoon the initial 6 inch interval, the sampling spoon is driven to a total penetration resistance of 100 blows or 18 inches, whichever occurs first. The sampling operation is terminated after a total of 100 hammer blows and the depth of penetration is recorded.

3. Hand Auger Borings

Hand auger borings HA-2, HA-3, HA-4, and HA-19 were advanced using a 3-inch diameter auger attached to steel rods and handle extensions. The auger is manually advanced from the ground surface with excavated soil removed from the borehole with each pass of the auger.

4. Test Boring Stakeout

The test boring stakeout was provided by GeoConcepts personnel using available site plans. If the risk related to using approximate boring locations is unacceptable, we recommend an as-drilled survey of boring locations and elevations be completed by a licensed surveyor.

Identification of Soil

I. DEFINITION OF SOIL GROUP NAMES		ASTM D-2487	Symbol	Group Name
Coarse-Grained Soils More than 50% retained on No. 200 sieve	Gravels More than 50% of coarse fraction retained on No. 4 sieve	Clean Gravels Less than 5% fines	<i>GW</i>	WELL GRADED GRAVEL
			<i>GP</i>	POORLY GRADED GRAVEL
		Gravels with Fines More than 12% fines	<i>GM</i>	silty GRAVEL
			<i>GC</i>	clayey GRAVEL
	Sands 50% or more of coarse fraction passes No. 4 sieve	Clean Sands Less than 5% fines	<i>SW</i>	WELL GRADED SAND
			<i>SP</i>	POORLY GRADED SAND
		Sands with fines More than 12% fines	<i>SM</i>	silty SAND
			<i>SC</i>	clayey SAND
Fine-Grained Soils 50% or more passes the No. 200 sieve	Silts and Clays Liquid Limit less than 50	Inorganic	<i>CL</i>	LEAN CLAY
			<i>ML</i>	SILT
		Organic	<i>OL</i>	ORGANIC CLAY
				ORGANIC SILT
	Silts and Clays Liquid Limit 50 or more	Inorganic	<i>CH</i>	FAT CLAY
			<i>MH</i>	ELASTIC SILT
		Organic	<i>OH</i>	ORGANIC CLAY
				ORGANIC SILT
Highly Organic Soils	Primarily organic matter, dark in color, and organic odor	<i>PT</i>	PEAT	

II. DEFINITION OF MINOR COMPONENT PROPORTIONS

<u>Minor Component</u>	<u>Approximate Percentage of Fraction by Weight</u>
Gravelly, Sandy (adjective)	30% or more coarse grained
Sand, Gravel	15% to 29% coarse grained
Silt, Clay	5% to 12% fine grained

III. GLOSSARY OF MISCELLANEOUS TERMS

SYMBOLS	Unified Soil Classification Symbols are shown above as group symbols. Use "A" Line Chart for laboratory identification. Dual symbols are used for borderline classification.
BOULDERS & COBBLES	Boulders are considered pieces of rock larger than 12 inches, while cobbles range from 3 to 12 inches.
IGM	Residual rock material with a standard penetration test (SPT) resistance of at least 60 blows per foot.
ROCK/SPOON REFUSAL	Rock material with a standard penetration test (SPT) resistance of 50 blows for 1 inch.
ROCK FRAGMENTS	Angular pieces of rock which have separated from original vein or strata and are present in a soil matrix. Only used in residual soils
QUARTZ	A hard silicate mineral often found in residual soils. Only used when describing residual soils.
CEMENTED SAND	Usually localized rock-like deposits within a soil stratum composed of sand grains cemented by calcium carbonate, iron oxide, or other minerals. Commonly encountered in Coastal Plain sediments, primarily in the Potomac Group sands (Kps).
MICACEOUS	A term used to describe soil that "glitters" or is shiny. Most commonly encountered in fine-grained soils.
ORGANIC MATERIALS (Excluding Peat)	Topsoil - Surface soils that support plant life and contain organic matter. Lignite - Hard, brittle decomposed organic matter with low fixed carbon content (a low grade of coal).
FILL	Man-made deposit containing soil, rock, and other foreign matter.
CONTAINS	This is used when a fill deposit contains a secondary component that does not apply to a USCS classification. Only used for fill deposits
WITH	This is used when a residual soil contains a secondary component that does not contribute to its USCS classification. Only used for natural soils.
PROBABLE FILL LAYERS	Soils which contain no visually detected foreign matter but which are suspect with regard to origin. ½ to 12 inch seam of minor soil component.
COLOR	Two most predominant colors present should be described.
MOISTURE CONDITIONS	Wet, moist, or dry to indicate visual appearance of specimen.

Test Boring Notes

1. Classification of soil is by visual inspection and is in accordance with ASTM D-2488.
2. Estimated groundwater levels are indicated on the logs. These are only estimates from available data and may vary with precipitation, porosity of soil, site topography, etc.
3. Sampling data presents standard penetrations for 6-inch intervals or as indicated with graphic representations adjacent to the sampling data.
4. The logs and related information depict subsurface conditions at the specific locations and at the particular time when drilled. Soil conditions at other locations may differ from conditions occurring at the test locations. Also, the passage of time may result in a change in the subsurface conditions at the test locations.
5. The stratification lines represent the approximate boundary between soil types as determined in the sampling operation. Some variation may be expected vertically between samples taken. The soil profile, groundwater level observations and penetration resistances presented on the logs have been made with reasonable care and accuracy and must be considered only an approximate representation of subsurface conditions to be encountered at the particular location.
6. Intermediate Geomaterial (IGM) is defined as residual earth material with a penetration resistance between 60 blows per foot and refusal. Spoon refusal at the surface of rock, boulders, or obstructions is defined as a penetration resistance of 50 blows for 0 inches penetration. Auger refusal is taken as the depth at which further penetration of the auger is not possible without risking significant damage to the drilling equipment.

Hand Auger Boring Notes

1. Classification of soil is by visual inspection and is in accordance with the Unified Soil Classification System. Soil classification symbols are in accordance with ASTM D-2488.
2. Estimated groundwater levels are indicated on the log. These are only estimates from available data and may vary with precipitation, porosity of soil, site topography, etc.
3. Sampling data presents Dynamic Cone Penetration (DCP) values for 1- $\frac{3}{4}$ inch intervals.
4. The logs and related information depict subsurface conditions at the specific locations and at the particular time when drilled. Soil conditions at other locations may differ from conditions occurring at the test locations. Also, the passage of time may result in a change in the subsurface conditions at the test locations.
5. The stratification lines represent the approximate boundary between soil types as determined in the sampling operation. Some variation may be expected vertically between samples taken. The soil profile, water level observations, and penetration resistances presented on the logs have been made with reasonable care and accuracy and must be considered only an approximate representation of subsurface conditions to be encountered at the particular locations.
6. Refusal depths on the hand auger logs are the depths at which obstructions were encountered and the hand auger could no longer be advanced.



PROJECT: Columbia Pike Multimodal Street Improvements		LOGGED BY: M. Showalter		BORING NUMBER: AB-12
LOCATION: Arlington County, Virginia		DRILLING CONTRACTOR: Connelly & Associates Inc.		
OWNER/CLIENT: Kimley-Horn and Associates, Inc.		DRILLER: K. Kersh	DATES DRILLED: 3/8/16 - 3/8/16	
PROJECT NUMBER: 14189	GROUND SURFACE ELEVATION (ft): 155.3	DRILLING METHOD: Automatic hammer 3.25" HSA		OFFSET NOTES:

ELEV. (ft)	DEPTH (ft)	SAMPLE TYPE	STRATUM	GRAPHIC	MATERIAL DESCRIPTION	SOIL						
						SPT BLOW COUNTS	REC (ft)	STANDARD PENETRATION TEST RESISTANCE (BPF)		MC (%)		
								20	40	60	80	
155.3	0.0				Asphalt = 0.38ft.							
154.9	0.6				Concrete = 0.6ft.							
154.3	0.6				Fill, orange, fine to medium, clayey SAND, medium dense, moist, SC	3+6+7+9	24					
	5		A			3+5+6+7	24					16.1
	10		A			4+7+7+7	24					14.9
	10		A			4+5+6+5	24					
	15		A			4+5+5+6	24					
	15		A			7+11+13	18					
136.8	18.0		C2		Terrace deposit, tan orange and brown, medium to coarse, WELL GRADED SAND with clay and gravel, medium dense, moist, SW-SC	14+15+11	18					

GROUND WATER LEVELS: ▽ ENCOUNTERED: <u>28.5</u> ft ELEV. <u>126.8</u> NOT ENCOUNTERED UPON COMPLETION	CAVED: <u>21.0</u> ft ELEV. <u>134.3</u>	SAMPLE TYPES: <input checked="" type="checkbox"/> Split Spoon
---	--	--

REMARKS: Bulk sample collected from 0.0 to 5.0 ft.

BOREHOLE/TEST PIT COLUMBIA PIKE MULTIMODAL STREET IMPROVEMENTS LOGS.GPJ GEOCONCEPTS TEMPLATE 02-12-2015.GDT 4/22/16

THE STRATIFICATION LINES REPRESENT APPROXIMATE BOUNDARIES. THE TRANSITION MAY BE GRADUAL.



PROJECT: Columbia Pike Multimodal Street Improvements	LOGGED BY: M. Showalter	BORING NUMBER: AB-12
LOCATION: Arlington County, Virginia	DRILLING CONTRACTOR: Connelly & Associates Inc.	

SHEET 2 OF 2

ELEV. (ft)	DEPTH (ft)	SAMPLE TYPE	STRATUM	GRAPHIC	MATERIAL DESCRIPTION	SOIL			
						SPT BLOW COUNTS	REC (in)	STANDARD PENETRATION TEST RESISTANCE (BPF) 20 40 60 80	MC (%)
131.8	25		C2		Dense	23+18+19	12		7.0
126.8	30				Wet	5+18+29	18		
121.8	35				Medium dense	5+7+9	18		26.4
120.3	35				Bottom of Boring at 35.0 ft				

GROUND WATER LEVELS: <input checked="" type="checkbox"/> ENCOUNTERED: <u>28.5</u> ft ELEV. <u>126.8</u> <input type="checkbox"/> NOT ENCOUNTERED UPON COMPLETION	<input checked="" type="checkbox"/> Split Spoon
CAVED: <u>21.0</u> ft ELEV. <u>134.3</u>	

REMARKS: Bulk sample collected from 0.0 to 5.0 ft.

BOREHOLE/TEST PIT COLUMBIA PIKE MULTIMODAL STREET IMPROVEMENTS LOGS.GPJ GEOCONCEPTS TEMPLATE 02-12-2015.GDT 4/22/16

PROJECT: Columbia Pike Multimodal Street Improvements		LOGGED BY: M. Showater	BORING NUMBER: AB-13
LOCATION: Arlington County, Virginia		DRILLING CONTRACTOR: Connelly & Associates Inc.	
OWNER/CLIENT: Kimley-Horn and Associates, Inc.		DRILLER: K. Kersh	DATES DRILLED: 3/8/16 - 3/8/16
PROJECT NUMBER: 14189	GROUND SURFACE ELEVATION (ft): 153.6	DRILLING METHOD: Automatic hammer 3.25" HSA	OFFSET NOTES:

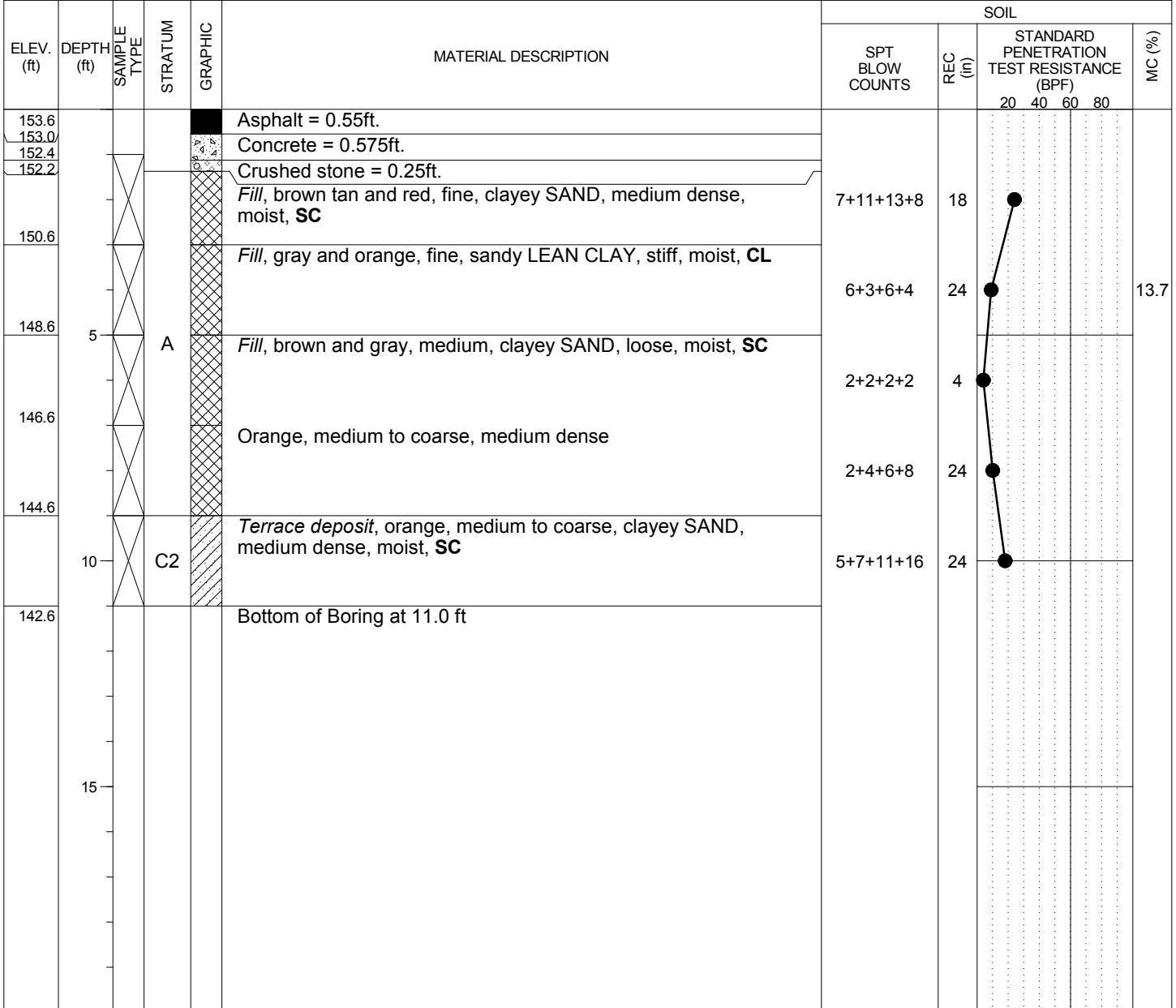

GROUND WATER LEVELS: NOT ENCOUNTERED DURING DRILLING NOT ENCOUNTERED UPON COMPLETION	CAVED: <u>7.0</u> ft ELEV. <u>146.6</u>	SAMPLE TYPES: <input checked="" type="checkbox"/> Split Spoon
--	---	--

REMARKS: Bulk sample collected from 0.0 to 5.0 ft.

THE STRATIFICATION LINES REPRESENT APPROXIMATE BOUNDARIES. THE TRANSITION MAY BE GRADUAL.

BOREHOLE/TEST PIT COLUMBIA PIKE MULTIMODAL STREET IMPROVEMENTS LOGS.GPJ GEOCONCEPTS TEMPLATE 02-12-2015.GDT 4/22/16



PROJECT: Columbia Pike Multimodal Street Improvements		LOGGED BY: M. Showater		BORING NUMBER: AB-14
LOCATION: Arlington County, Virginia		DRILLING CONTRACTOR: Connelly & Associates Inc.		
OWNER/CLIENT: Kimley-Horn and Associates, Inc.		DRILLER: K. Kersh	DATES DRILLED: 3/8/16 - 3/8/16	
PROJECT NUMBER: 14189	GROUND SURFACE ELEVATION (ft): 151.8	DRILLING METHOD: Automatic hammer 3.25" HSA	OFFSET NOTES:	

ELEV. (ft)	DEPTH (ft)	SAMPLE TYPE	STRATUM	GRAPHIC	MATERIAL DESCRIPTION	SOIL							
						SPT BLOW COUNTS	REC (ft)	STANDARD PENETRATION TEST RESISTANCE (BPF)		MC (%)			
								20	40		60	80	
151.8					Asphalt = 0.55ft.								
151.3					Concrete = 0.575ft.								
150.7					Fill, gray and orange, clayey SAND, medium dense, moist, SC	7+9+11+13	24						10.5
148.7			A		Fill, orange, LEAN CLAY with sand, very stiff, moist, CL	5+8+10+13	24						
146.7	5				Terrace deposit, orange and gray, fine, clayey SAND, medium dense, moist, SC	8+14+16+21	24						
144.7			C2		Orange and white, medium to coarse, with gravel, dense	9+17+14+12	24						
142.7	10				Medium dense	3+8+8+12	24						
140.7					Bottom of Boring at 11.1 ft								

GROUND WATER LEVELS: NOT ENCOUNTERED DURING DRILLING NOT ENCOUNTERED UPON COMPLETION	CAVED: <u>5.5</u> ft ELEV. <u>146.3</u>	SAMPLE TYPES: <input checked="" type="checkbox"/> Split Spoon
--	---	--

REMARKS:

THE STRATIFICATION LINES REPRESENT APPROXIMATE BOUNDARIES. THE TRANSITION MAY BE GRADUAL.

BOREHOLE/TEST PIT COLUMBIA PIKE MULTIMODAL STREET IMPROVEMENTS LOGS.GPJ GEOCONCEPTS TEMPLATE 02-12-2015.GDT 4/26/16



PROJECT: Columbia Pike Multimodal Street Improvements		LOGGED BY: M. Showater		BORING NUMBER: AB-15
LOCATION: Arlington County, Virginia		DRILLING CONTRACTOR: Connelly & Associates Inc.		
OWNER/CLIENT: Kimley-Horn and Associates, Inc.		DRILLER: K. Kersh	DATES DRILLED: 3/8/16 - 3/8/16	
PROJECT NUMBER: 14189	GROUND SURFACE ELEVATION (ft): 148.6	DRILLING METHOD: Automatic hammer 3.25" HSA	OFFSET NOTES:	

ELEV. (ft)	DEPTH (ft)	SAMPLE TYPE	STRATUM	GRAPHIC	MATERIAL DESCRIPTION	SOIL						
						SPT BLOW COUNTS	REC (ft)	STANDARD PENETRATION TEST RESISTANCE (BPF)		MC (%)		
								20	40	60	80	
148.6					Asphalt = 0.5ft.							
148.1					Concrete = 0.58ft.							
147.5												
			A		Fill, orange, coarse, clayey SAND with gravel, medium dense, moist, SC	6+10+12+14	24					10.1
145.6												
					Terrace deposit, orange, medium, clayey SAND with gravel, medium dense, moist, SC	1+10+11+12	24					14.2
143.5	5				Coarse							
			C2									
	10					8+11+13+14	24					
						6+8+9+11	24					
						5+5+13+15	24					
137.6					Bottom of Boring at 11.0 ft							

GROUND WATER LEVELS: NOT ENCOUNTERED DURING DRILLING NOT ENCOUNTERED UPON COMPLETION	CAVED: <u>5.0</u> ft ELEV. <u>143.6</u>	SAMPLE TYPES: <input checked="" type="checkbox"/> Split Spoon
--	---	--

REMARKS: Bulk sample collected from 0.0 to 5.0 ft.

BOREHOLE/TEST PIT COLUMBIA PIKE MULTIMODAL STREET IMPROVEMENTS LOGS.GPJ GEOCONCEPTS TEMPLATE 02-12-2015.GDT 4/22/16

THE STRATIFICATION LINES REPRESENT APPROXIMATE BOUNDARIES. THE TRANSITION MAY BE GRADUAL.



PROJECT: Columbia Pike Multimodal Street Improvements		LOGGED BY: M. Showater		BORING NUMBER: AB-16
LOCATION: Arlington County, Virginia		DRILLING CONTRACTOR: Connelly & Associates Inc.		
OWNER/CLIENT: Kimley-Horn and Associates, Inc.		DRILLER: K. Kersh	DATES DRILLED: 3/8/16 - 3/8/16	
PROJECT NUMBER: 14189	GROUND SURFACE ELEVATION (ft): 146.2	DRILLING METHOD: Automatic hammer 3.25" HSA		SHEET 1 OF 1

ELEV. (ft)	DEPTH (ft)	SAMPLE TYPE	STRATUM	GRAPHIC	MATERIAL DESCRIPTION	SOIL				
						SPT BLOW COUNTS	REC (ft)	STANDARD PENETRATION TEST RESISTANCE (BPF) 20 40 60 80		MC (%)
146.2					Asphalt = 0.5ft.					
145.7					Concrete = 0.75ft.					
144.9					Fill, brown, clayey SAND, loose, moist, SC	1+3+3+5	18			10.4
142.9			A		Fill, orange and brown, LEAN CLAY, very stiff, moist, CL	3+8+10+5	12			
139.2	5				Contains intact clay brick Terrace deposit, gray, fine, sandy silty CLAY, contains organics, soft, moist, CL-ML	8+3+4+3	18			
138.9			C1			1+1+1+1	24			18.5
136.9	10				Terrace deposit, gray, fine to coarse, clayey SAND with gravel, loose, moist, SC	1+3+7+9	12			
134.9			C2			Bottom of Boring at 11.3 ft				

GROUND WATER LEVELS: NOT ENCOUNTERED DURING DRILLING NOT ENCOUNTERED UPON COMPLETION	CAVED: <u>6.5</u> ft ELEV. <u>139.7</u>	SAMPLE TYPES: <input checked="" type="checkbox"/> Split Spoon
--	---	--

REMARKS:

THE STRATIFICATION LINES REPRESENT APPROXIMATE BOUNDARIES. THE TRANSITION MAY BE GRADUAL.

BOREHOLE/TEST PIT COLUMBIA PIKE MULTIMODAL STREET IMPROVEMENTS LOGS.GPJ GEOCONCEPTS TEMPLATE 02-12-2015.GDT 4/26/16

PROJECT: Columbia Pike Multimodal Street Improvements		LOGGED BY: L. Pugh	BORING NUMBER: CRW-1
LOCATION: Columbia Pike, Arlington, VA		DRILLING CONTRACTOR: Connelly & Associates, Inc.	
OWNER/CLIENT: Kimley-Horn & Associates, Inc.		DRILLER: K. Kersh	DATES DRILLED: 2/27/15 - 2/27/15
PROJECT NUMBER: 14189	GROUND SURFACE ELEVATION (ft): NOT SURVEYED	DRILLING METHOD: 2.25" H.S.A	OFFSET NOTES:

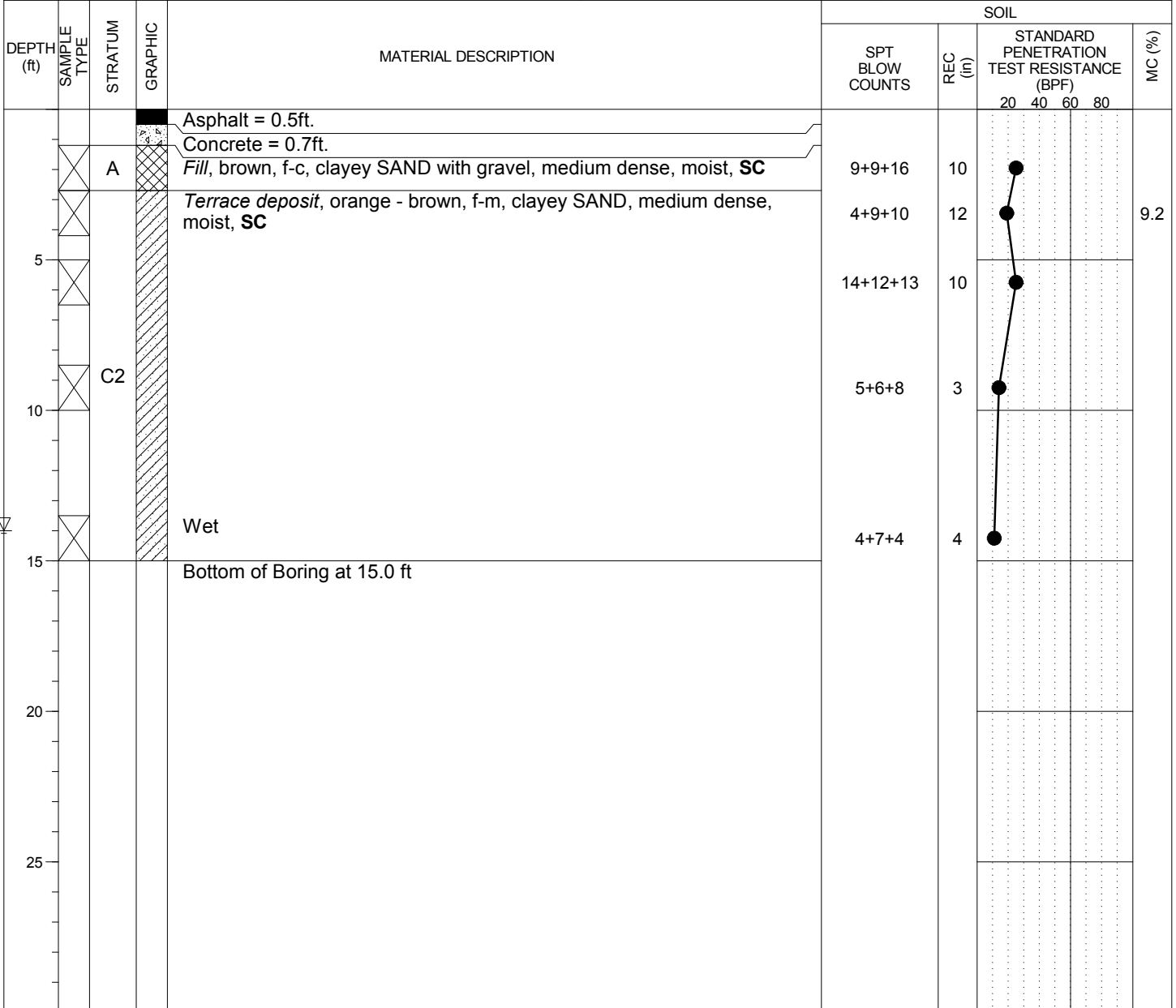

GROUND WATER LEVELS: ▽ ENCOUNTERED: <u>14.0</u> ft NOT ENCOUNTERED UPON COMPLETION CAVED: <u>8.0</u> ft	SAMPLE TYPES: <input checked="" type="checkbox"/> Split Spoon
--	--

REMARKS:

THE STRATIFICATION LINES REPRESENT APPROXIMATE BOUNDARIES. THE TRANSITION MAY BE GRADUAL.

BOREHOLE/TEST PIT SEG. D&C LOGS.GPJ GEOCONCEPTS TEMPLATE 02-12-2015.GDT 4/22/16



PROJECT: Columbia Pike Multimodal Street Improvements		LOGGED BY: L. Pugh	BORING NUMBER: CRW-2
LOCATION: Columbia Pike, Arlington, VA		DRILLING CONTRACTOR: Connelly & Associates, Inc.	
OWNER/CLIENT: Kimley-Horn & Associates, Inc.		DRILLER: K. Kersh	DATES DRILLED: 2/27/15 - 2/27/15
PROJECT NUMBER: 14189	GROUND SURFACE ELEVATION (ft): NOT SURVEYED	DRILLING METHOD: 2.25" H.S.A	OFFSET NOTES:

DEPTH (ft)	SAMPLE TYPE	STRATUM	GRAPHIC	MATERIAL DESCRIPTION	SOIL						
					SPT BLOW COUNTS	REC (ft)	STANDARD PENETRATION TEST RESISTANCE (BPF)				MC (%)
							20	40	60	80	
				Asphalt = 0.8ft.							
				Concrete = 0.4ft.							
		A		Fill, brown, f, clayey SAND, loose, moist, SC Medium dense	9+5+5	14				4.2	
5				Terrace deposit, brown, f-c, clayey SAND, medium dense, moist, SC	4+7+7	14					
		C2		Orange - brown	6+9+16	1					
10				With gravel	5+5+8	18					
15				Bottom of Boring at 15.0 ft	9+9+16	10					

GROUND WATER LEVELS: NOT ENCOUNTERED DURING DRILLING NOT ENCOUNTERED UPON COMPLETION CAVED: <u>3.5</u> ft	SAMPLE TYPES: <input checked="" type="checkbox"/> Split Spoon
--	--

REMARKS: Bulk sample from 0' to 5'

BOREHOLE/TEST PIT SEG. D&C LOGS.GPJ GEOCONCEPTS TEMPLATE 02-12-2015.GDT 4/22/16

THE STRATIFICATION LINES REPRESENT APPROXIMATE BOUNDARIES. THE TRANSITION MAY BE GRADUAL.

PROJECT: Columbia Pike Multimodal Street Improvements		LOGGED BY: L. Pugh	BORING NUMBER: CB-3
LOCATION: Columbia Pike, Arlington, VA		DRILLING CONTRACTOR: Connelly & Associates, Inc.	
OWNER/CLIENT: Kimley-Horn & Associates, Inc.		DRILLER: K. Kersh	DATES DRILLED: 2/27/15 - 2/27/15
PROJECT NUMBER: 14189	GROUND SURFACE ELEVATION (ft): NOT SURVEYED	DRILLING METHOD: 2.25" H.S.A	OFFSET NOTES:

DEPTH (ft)	SAMPLE TYPE	STRATUM	GRAPHIC	MATERIAL DESCRIPTION	SOIL						
					SPT BLOW COUNTS	REC (ft)	STANDARD PENETRATION TEST RESISTANCE (BPF)		MC (%)		
							20	40	60	80	
			Asphalt = 0.6ft.								
			Concrete = 0.6ft.								
		C1		<i>Terrace deposit</i> , brown, f, sandy silty CLAY with gravel, stiff, moist, CL-ML Brown and gray	7+7+4	10					14.4
					2+4+6	12					
5		C2		<i>Terrace deposit</i> , light brown, f, clayey SAND, medium dense, moist, SC	4+7+10	5					11.6
					14+17+17	10					
10				Orange - brown, f-c, with gravel, dense							
				Bottom of Boring at 10.0 ft							
15											
20											
25											

GROUND WATER LEVELS: NOT ENCOUNTERED DURING DRILLING NOT ENCOUNTERED UPON COMPLETION CAVED: <u>3.3</u> ft	SAMPLE TYPES: <input checked="" type="checkbox"/> Split Spoon
--	--

REMARKS:

THE STRATIFICATION LINES REPRESENT APPROXIMATE BOUNDARIES. THE TRANSITION MAY BE GRADUAL.



PROJECT: Columbia Pike Multimodal Street Improvements		LOGGED BY: L. Pugh		BORING NUMBER: CB-4
LOCATION: Columbia Pike, Arlington, VA		DRILLING CONTRACTOR: Connelly & Associates, Inc.		
OWNER/CLIENT: Kimley-Horn & Associates, Inc.		DRILLER: C. Wolfe	DATES DRILLED: 2/25/15 - 2/25/15	
PROJECT NUMBER: 14189	GROUND SURFACE ELEVATION (ft): NOT SURVEYED	DRILLING METHOD: 2.25" H.S.A	OFFSET NOTES:	

DEPTH (ft)	SAMPLE TYPE	STRATUM	GRAPHIC	MATERIAL DESCRIPTION	SOIL				
					SPT BLOW COUNTS	REC (ft)	STANDARD PENETRATION TEST RESISTANCE (BPF) 20 40 60 80		MC (%)
				Asphalt = 0.5ft.					
				Concrete = 0.6ft.					
		C1		Terrace deposit, brown, LEAN CLAY with gravel, very stiff, moist, CL	15+12+8	6	●		18.7
				Terrace deposit, white, f-c, POORLY GRADED GRAVEL with sand, very dense, moist, GP	40+41+34	12	●		
5		C2			12+17+22	2	●		4.8
				Terrace deposit, orange - brown, f-c, clayey SAND, medium dense, moist, SC	3+6+5	18	●		
10				Bottom of Boring at 10.0 ft					

GROUND WATER LEVELS: NOT ENCOUNTERED DURING DRILLING NOT ENCOUNTERED UPON COMPLETION CAVED: <u>5.8</u> ft	SAMPLE TYPES: <input checked="" type="checkbox"/> Split Spoon
--	--

REMARKS:

THE STRATIFICATION LINES REPRESENT APPROXIMATE BOUNDARIES. THE TRANSITION MAY BE GRADUAL.

BOREHOLE/TEST PIT SEG. D&C LOGS.GPJ GEOCONCEPTS TEMPLATE 02-12-2015.GDT 4/26/16

PROJECT: Columbia Pike Multimodal Street Improvements		LOGGED BY: L. Pugh	BORING NUMBER: CB-5
LOCATION: Columbia Pike, Arlington , VA		DRILLING CONTRACTOR: Connelly & Associates, Inc.	
OWNER/CLIENT: Kimley-Horn & Associates, Inc.		DRILLER: C. Wolfe	DATES DRILLED: 2/25/15 - 2/25/15
PROJECT NUMBER: 14189	GROUND SURFACE ELEVATION (ft): NOT SURVEYED	DRILLING METHOD: 2.25" H.S.A	OFFSET NOTES:

DEPTH (ft)	SAMPLE TYPE	STRATUM	GRAPHIC	MATERIAL DESCRIPTION	SOIL						
					SPT BLOW COUNTS	REC (ft)	STANDARD PENETRATION TEST RESISTANCE (BPF)		MC (%)		
							20	40	60	80	
			Asphalt = 0.6ft.								
			Concrete = 0.5ft.								
			<i>Terrace deposit</i> , light brown, f-m, sandy LEAN CLAY, stiff, moist, CL		11+5+7	18					9.7
		C1	White and brown, very stiff		6+8+9	18					
5			<i>Terrace deposit</i> , black, f-c, clayey SAND, moist, SC		5+6+7	3					
		C2	<i>Terrace deposit</i> , orange - brown, f, LEAN CLAY with sand, firm, moist, CL		3+3+4	16					23.3
10		C1	Bottom of Boring at 10.0 ft								
15											
20											
25											

GROUND WATER LEVELS: NOT ENCOUNTERED DURING DRILLING NOT ENCOUNTERED UPON COMPLETION CAVED: <u>5.6</u> ft	SAMPLE TYPES: <input checked="" type="checkbox"/> Split Spoon
--	--

REMARKS: Bulk sample from 0' to 5'

BOREHOLE/TEST PIT SEG. D&C LOGS.GPJ GEOCONCEPTS TEMPLATE 02-12-2015.GDT 4/26/16

PROJECT: Columbia Pike Multimodal Street Improvements		LOGGED BY: L. Pugh	BORING NUMBER: CB-6
LOCATION: Columbia Pike, Arlington , VA		DRILLING CONTRACTOR: Connelly & Associates, Inc.	
OWNER/CLIENT: Kimley-Horn & Associates, Inc.		DRILLER: C. Wolfe	DATES DRILLED: 2/25/15 - 2/25/15
PROJECT NUMBER: 14189	GROUND SURFACE ELEVATION (ft): NOT SURVEYED	DRILLING METHOD: 2.25" H.S.A	OFFSET NOTES:

DEPTH (ft)	SAMPLE TYPE	STRATUM	GRAPHIC	MATERIAL DESCRIPTION	SOIL		
					SPT BLOW COUNTS	REC (ft)	STANDARD PENETRATION TEST RESISTANCE (BPF) 20 40 60 80
				Asphalt = 0.6ft.			
				Concrete = 0.5ft.			
				<i>Terrace deposit</i> , brown, f-m, clayey SAND with gravel, medium dense, moist, SC	14+11+7	14	●
					4+8+14	18	●
5		C2			4+5+8	3	●
10				Bottom of Boring at 10.0 ft	4+8+11	2	●
15							
20							
25							

GROUND WATER LEVELS: NOT ENCOUNTERED DURING DRILLING NOT ENCOUNTERED UPON COMPLETION CAVED: <u>5.3</u> ft	SAMPLE TYPES: <input checked="" type="checkbox"/> Split Spoon
--	--

REMARKS:

THE STRATIFICATION LINES REPRESENT APPROXIMATE BOUNDARIES. THE TRANSITION MAY BE GRADUAL.

PROJECT: Columbia Pike Multimodal Street Improvements		LOGGED BY: L. Pugh	BORING NUMBER: CB-7
LOCATION: Columbia Pike, Arlington, VA		DRILLING CONTRACTOR: Connelly & Associates, Inc.	
OWNER/CLIENT: Kimley-Horn & Associates, Inc.		DRILLER: C. Wolfe	DATES DRILLED: 2/25/15 - 2/25/15
PROJECT NUMBER: 14189	GROUND SURFACE ELEVATION (ft): NOT SURVEYED	DRILLING METHOD: 2.25" H.S.A	OFFSET NOTES:

DEPTH (ft)	SAMPLE TYPE	STRATUM	GRAPHIC	MATERIAL DESCRIPTION	SOIL						
					SPT BLOW COUNTS	REC (ft)	STANDARD PENETRATION TEST RESISTANCE (BPF)		MC (%)		
							20	40	60	80	
			Asphalt = 0.6ft.								
			Concrete = 0.5ft.								
			<i>Terrace deposit</i> , brown, f-c, clayey SAND with gravel, medium dense, moist, SC		11+8+14	10					
5		C2			8+15+8	12					5.3
					5+6+7	6					
10		C1	<i>Terrace deposit</i> , orange - brown, f, LEAN CLAY with sand, stiff, moist, CL		5+4+5	12					22.5
				Bottom of Boring at 10.0 ft							

GROUND WATER LEVELS: NOT ENCOUNTERED DURING DRILLING NOT ENCOUNTERED UPON COMPLETION CAVED: <u>5.0</u> ft	SAMPLE TYPES: <input checked="" type="checkbox"/> Split Spoon
--	--

REMARKS:

THE STRATIFICATION LINES REPRESENT APPROXIMATE BOUNDARIES. THE TRANSITION MAY BE GRADUAL.

BOREHOLE/TEST PIT SEG. D&C LOGS.GPJ GEOCONCEPTS TEMPLATE 02-12-2015.GDT 4/26/16



PROJECT: Columbia Pike Multimodal Street Improvements		LOGGED BY: L. Pugh		BORING NUMBER: CB-8
LOCATION: Columbia Pike, Arlington, VA		DRILLING CONTRACTOR: Connelly & Associates, Inc.		
OWNER/CLIENT: Kimley-Horn & Associates, Inc.		DRILLER: T. Chew	DATES DRILLED: 2/24/15 - 2/24/15	
PROJECT NUMBER: 14189	GROUND SURFACE ELEVATION (ft): NOT SURVEYED	DRILLING METHOD: 2.25" H.S.A	OFFSET NOTES:	

DEPTH (ft)	SAMPLE TYPE	STRATUM	GRAPHIC	MATERIAL DESCRIPTION	SPT BLOW COUNTS	SOIL				MC (%)	
						REC (ft)	STANDARD PENETRATION TEST RESISTANCE (BPF)				
							20	40	60	80	
				Asphalt = 0.5ft.							
				Concrete = 0.6ft.							
	X	C2		Terrace deposit, brown, f, clayey SAND, very loose, moist, SC	3+2+2	18					16.6
	X	C1		Terrace deposit, brown, f, LEAN CLAY with sand, firm, moist, CL	2+5+3	18					21.2
5	X			Terrace deposit, dark orange - brown, f-c, clayey SAND with gravel, medium dense, moist, SC	11+7+9	18					13.7
	X	C2									
10				Bottom of Boring at 10.0 ft	13+14+15	18					

GROUND WATER LEVELS: NOT ENCOUNTERED DURING DRILLING NOT ENCOUNTERED UPON COMPLETION CAVED: <u>5.1</u> ft	SAMPLE TYPES: <input checked="" type="checkbox"/> Split Spoon
--	--

REMARKS: Bulk sample from 0' to 5'

BOREHOLE/TEST PIT SEG. D&C LOGS.GPJ GEOCONCEPTS TEMPLATE 02-12-2015.GDT 4/28/16

THE STRATIFICATION LINES REPRESENT APPROXIMATE BOUNDARIES. THE TRANSITION MAY BE GRADUAL.



PROJECT: Columbia Pike Multimodal Street Improvements		LOGGED BY: L. Pugh		BORING NUMBER: CB-9
LOCATION: Columbia Pike, Arlington , VA		DRILLING CONTRACTOR: Connelly & Associates, Inc.		
OWNER/CLIENT: Kimley-Horn & Associates, Inc.		DRILLER: C. Wolfe	DATES DRILLED: 2/25/15 - 2/25/15	
PROJECT NUMBER: 14189	GROUND SURFACE ELEVATION (ft): NOT SURVEYED	DRILLING METHOD: 2.25" H.S.A	OFFSET NOTES:	

DEPTH (ft)	SAMPLE TYPE	STRATUM	GRAPHIC	MATERIAL DESCRIPTION	SPT BLOW COUNTS	REC (ft)	SOIL				MC (%)
							STANDARD PENETRATION TEST RESISTANCE (BPF)				
							20	40	60	80	
				Asphalt = 0.5ft.							
				Concrete = 0.8ft.							
				Terrace deposit, brown, f-m, clayey SAND with gravel, medium dense, moist, SC Dark orange - brown, dense	10+13+10	18					
					8+11+22	18					
5		C2		Light brown, f-c, POORLY GRADED GRAVEL with sand, very dense, moist, GP	22+30+24	6					
10				Bottom of Boring at 10.0 ft	39+34+38	18					5.8

GROUND WATER LEVELS: <input type="checkbox"/> ENCOUNTERED: <u>8.0</u> ft NOT ENCOUNTERED UPON COMPLETION CAVED: <u>5.2</u> ft	SAMPLE TYPES: <input checked="" type="checkbox"/> Split Spoon
--	--

REMARKS:

THE STRATIFICATION LINES REPRESENT APPROXIMATE BOUNDARIES. THE TRANSITION MAY BE GRADUAL.

BOREHOLE/TEST PIT SEG. D&C LOGS.GPJ GEOCONCEPTS TEMPLATE 02-12-2015.GDT 4/22/16



PROJECT: Columbia Pike Multimodal Street Improvements		LOGGED BY: L. Pugh		BORING NUMBER: DB-1
LOCATION: Columbia Pike, Arlington, VA		DRILLING CONTRACTOR: Connelly & Associates, Inc.		
OWNER/CLIENT: Kimley-Horn & Associates, Inc.		DRILLER: T. Chew	DATES DRILLED: 2/23/15 - 2/23/15	
PROJECT NUMBER: 14189	GROUND SURFACE ELEVATION (ft): NOT SURVEYED	DRILLING METHOD: 2.25" H.S.A	OFFSET NOTES:	

DEPTH (ft)	SAMPLE TYPE	STRATUM	GRAPHIC	MATERIAL DESCRIPTION	SOIL					
					SPT BLOW COUNTS	REC (ft)	STANDARD PENETRATION TEST RESISTANCE (BPF)		MC (%)	
							20	40		60
				Asphalt = 0.2ft. Concrete = 0.6ft.						
		C1		Terrace deposit, orange - brown, f, LEAN CLAY with sand, and gravel, stiff, moist, CL Very stiff	3+4+6	18				12.1
5		C2		Terrace deposit, orange brown and red, f-c, clayey SAND with gravel, medium dense, moist, SC	8+11+13	18				
				Dense	12+14+15	18				
10				Bottom of Boring at 10.0 ft	13+15+17	18				



GROUND WATER LEVELS: NOT ENCOUNTERED DURING DRILLING NOT ENCOUNTERED UPON COMPLETION CAVED: <u>5.1</u> ft	SAMPLE TYPES: <input checked="" type="checkbox"/> Split Spoon
--	--

REMARKS:

THE STRATIFICATION LINES REPRESENT APPROXIMATE BOUNDARIES. THE TRANSITION MAY BE GRADUAL.

BOREHOLE/TEST PIT SEG. D&C LOGS.GPJ GEOCONCEPTS TEMPLATE 02-12-2015.GDT 4/26/16

PROJECT: Columbia Pike Multimodal Street Improvements		LOGGED BY: L. Pugh	BORING NUMBER: DB-2
LOCATION: Columbia Pike, Arlington , VA		DRILLING CONTRACTOR: Connelly & Associates, Inc.	
OWNER/CLIENT: Kimley-Horn & Associates, Inc.		DRILLER: T. Chew	DATES DRILLED: 2/23/15 - 2/23/15
PROJECT NUMBER: 14189	GROUND SURFACE ELEVATION (ft): NOT SURVEYED	DRILLING METHOD: 2.25" H.S.A	OFFSET NOTES:









DEPTH (ft)	SAMPLE TYPE	STRATUM	GRAPHIC	MATERIAL DESCRIPTION	SOIL					
					SPT BLOW COUNTS	REC (ft)	STANDARD PENETRATION TEST RESISTANCE (BPF)		MC (%)	
							20	40		60
				Asphalt = 0.4ft.						
				Concrete = 0.5ft.						
				<i>Terrace deposit</i> , orange - brown, sandy FAT CLAY with gravel, micaceous, stiff, moist, CH Very stiff	5+7+6	18				17.5
5		C1		Without gravel	8+10+15	18				21.7
					18+16+13	18				
10		C2		<i>Terrace deposit</i> , orange - brown, f, clayey SAND, medium dense, moist, SC	8+10+8	18				
				Bottom of Boring at 10.0 ft						

GROUND WATER LEVELS: NOT ENCOUNTERED DURING DRILLING NOT ENCOUNTERED UPON COMPLETION CAVED: <u>4.7</u> ft	SAMPLE TYPES: <input checked="" type="checkbox"/> Split Spoon
--	--

REMARKS: Bulk sample from 0' to 5'

THE STRATIFICATION LINES REPRESENT APPROXIMATE BOUNDARIES. THE TRANSITION MAY BE GRADUAL.

PROJECT: Columbia Pike Multimodal Street Improvements		LOGGED BY: L. Pugh	BORING NUMBER: DB-3
LOCATION: Columbia Pike, Arlington , VA		DRILLING CONTRACTOR: Connelly & Associates, Inc.	
OWNER/CLIENT: Kimley-Horn & Associates, Inc.		DRILLER: T. Chew	DATES DRILLED: 2/23/15 - 2/23/15
PROJECT NUMBER: 14189	GROUND SURFACE ELEVATION (ft): NOT SURVEYED	DRILLING METHOD: 2.25" H.S.A	OFFSET NOTES:

DEPTH (ft)	SAMPLE TYPE	STRATUM	GRAPHIC	MATERIAL DESCRIPTION	SOIL		
					SPT BLOW COUNTS	REC (ft)	STANDARD PENETRATION TEST RESISTANCE (BPF) 20 40 60 80
				Asphalt = 0.2ft. Concrete = 0.6ft.			
		C2		<i>Terrace deposit</i> , brown, f-c, clayey SAND with gravel, dense, moist, SC Medium dense	15+15+32	18	
5		C1		<i>Terrace deposit</i> , orange - brown, f, LEAN CLAY with sand, firm, moist, CL	33+14+9	4	
		C1			3+4+4	3	
10		C2		<i>Terrace deposit</i> , white, f, clayey SAND, medium dense, SC	4+4+7	18	
				Bottom of Boring at 10.0 ft			

GROUND WATER LEVELS: NOT ENCOUNTERED DURING DRILLING NOT ENCOUNTERED UPON COMPLETION CAVED: <u>5.2</u> ft	SAMPLE TYPES: <input checked="" type="checkbox"/> Split Spoon
--	--

REMARKS:

THE STRATIFICATION LINES REPRESENT APPROXIMATE BOUNDARIES. THE TRANSITION MAY BE GRADUAL.

BOREHOLE/TEST PIT SEG. D&C LOGS.GPJ GEOCONCEPTS TEMPLATE 02-12-2015.GDT 4/26/16



PROJECT: Columbia Pike Multimodal Street Improvements		LOGGED BY: L. Pugh		BORING NUMBER: DB-4
LOCATION: Columbia Pike, Arlington , VA		DRILLING CONTRACTOR: Connelly & Associates, Inc.		
OWNER/CLIENT: Kimley-Horn & Associates, Inc.		DRILLER: T. Chew	DATES DRILLED: 2/19/15 - 2/19/15	
PROJECT NUMBER: 14189	GROUND SURFACE ELEVATION (ft): NOT SURVEYED	DRILLING METHOD: 2.25" H.S.A	OFFSET NOTES:	

DEPTH (ft)	SAMPLE TYPE	STRATUM	GRAPHIC	MATERIAL DESCRIPTION	SOIL				
					SPT BLOW COUNTS	REC (ft)	STANDARD PENETRATION TEST RESISTANCE (BPF) 20 40 60 80		
				Asphalt = 0.9ft.					
				Crushed stone = 0.1ft.					
		A		Fill, gray - brown, clayey GRAVEL with sand, loose, moist, GC	8+5+5	12			13.4
5		C1		Terrace deposit, orange - brown, LEAN CLAY, micaceous, soft, moist, CL	5+4+3	18			
		C2		Terrace deposit, orange - brown, clayey SAND with gravel, medium dense, moist, SC	5+2+1	6			
10				Bottom of Boring at 10.0 ft	3+5+12	18			

GROUND WATER LEVELS: NOT ENCOUNTERED DURING DRILLING NOT ENCOUNTERED UPON COMPLETION CAVED: <u>4.7</u> ft	SAMPLE TYPES: <input checked="" type="checkbox"/> Split Spoon
--	--

REMARKS:

THE STRATIFICATION LINES REPRESENT APPROXIMATE BOUNDARIES. THE TRANSITION MAY BE GRADUAL.

BOREHOLE/TEST PIT SEG. D&C LOGS.GPJ GEOCONCEPTS TEMPLATE 02-12-2015.GDT 4/26/16



PROJECT: Columbia Pike Multimodal Street Improvements		LOGGED BY: L. Pugh		BORING NUMBER: DB-5
LOCATION: Columbia Pike, Arlington , VA		DRILLING CONTRACTOR: Connelly & Associates, Inc.		
OWNER/CLIENT: Kimley-Horn & Associates, Inc.		DRILLER: T. Chew	DATES DRILLED: 2/19/15 - 2/19/15	
PROJECT NUMBER: 14189	GROUND SURFACE ELEVATION (ft): NOT SURVEYED	DRILLING METHOD: 2.25" H.S.A	OFFSET NOTES:	

DEPTH (ft)	SAMPLE TYPE	STRATUM	GRAPHIC	MATERIAL DESCRIPTION	SOIL				
					SPT BLOW COUNTS	REC (ft)	STANDARD PENETRATION TEST RESISTANCE (BPF) 20 40 60 80		MC (%)
				Asphalt = 0.8ft.					
				Crushed stone = 0.1ft.					
				Fill, gray - brown, f-c, POORLY GRADED SAND with gravel, dense, moist, SP Very dense	7+18+15	18	●		
					23+35+48	18	●		
5		A			50/3	3	●		4.0
					26+27+33	18	●		
10				Bottom of Boring at 10.0 ft					
15									
20									
25									

GROUND WATER LEVELS: NOT ENCOUNTERED DURING DRILLING NOT ENCOUNTERED UPON COMPLETION CAVED: <u>5.2</u> ft	SAMPLE TYPES: <input checked="" type="checkbox"/> Split Spoon
--	--

REMARKS:

THE STRATIFICATION LINES REPRESENT APPROXIMATE BOUNDARIES. THE TRANSITION MAY BE GRADUAL.

BOREHOLE/TEST PIT SEG. D&C LOGS.GPJ GEOCONCEPTS TEMPLATE 02-12-2015.GDT 4/22/16

PROJECT: Columbia Pike Multimodal Street Improvements		LOGGED BY: L. Pugh	BORING NUMBER: DB-6
LOCATION: Columbia Pike, Arlington, VA		DRILLING CONTRACTOR: Connelly & Associates, Inc.	
OWNER/CLIENT: Kimley-Horn & Associates, Inc.		DRILLER: T. Chew	DATES DRILLED: 2/19/15 - 2/19/15
PROJECT NUMBER: 14189	GROUND SURFACE ELEVATION (ft): NOT SURVEYED	DRILLING METHOD: 2.25" H.S.A	OFFSET NOTES:

DEPTH (ft)	SAMPLE TYPE	STRATUM	GRAPHIC	MATERIAL DESCRIPTION	SOIL					
					SPT BLOW COUNTS	REC (ft)	STANDARD PENETRATION TEST RESISTANCE (BPF)			MC (%)
					20	40	60	80		
0				Asphalt = 0.3ft.						
0				Concrete = 0.5ft.						
0		C2		<i>Terrace deposit</i> , orange - brown, f, clayey SAND with gravel, very loose, moist, SC	3+1+2	2				11.0
5				Brown, loose	3+2+2	12				
5		C1		<i>Terrace deposit</i> , orange - brown, f, LEAN CLAY with sand, stiff, moist, CL	3+4+5	18				
10				Gray, without sand	5+6+6	18				
10				Bottom of Boring at 10.0 ft						

GROUND WATER LEVELS: NOT ENCOUNTERED DURING DRILLING NOT ENCOUNTERED UPON COMPLETION CAVED: <u>4.9</u> ft	SAMPLE TYPES: <input checked="" type="checkbox"/> Split Spoon
--	--

REMARKS: Bulk sample from 0' to 5'

BOREHOLE/TEST PIT SEG. D&C LOGS.GPJ GEOCONCEPTS TEMPLATE 02-12-2015.GDT 4/26/16

PROJECT: Columbia Pike Multimodal Street Improvements		LOGGED BY: L. Pugh	BORING NUMBER: DB-7
LOCATION: Columbia Pike, Arlington , VA		DRILLING CONTRACTOR: Connelly & Associates, Inc.	
OWNER/CLIENT: Kimley-Horn & Associates, Inc.		DRILLER: R. Wilcher	DATES DRILLED: 2/12/15 - 2/12/15
PROJECT NUMBER: 14189	GROUND SURFACE ELEVATION (ft): NOT SURVEYED	DRILLING METHOD: 2.25" H.S.A	OFFSET NOTES:

DEPTH (ft)	SAMPLE TYPE	STRATUM	GRAPHIC	MATERIAL DESCRIPTION	SOIL					
					SPT BLOW COUNTS	REC (ft)	STANDARD PENETRATION TEST RESISTANCE (BPF)		MC (%)	
					20	40	60	80		
				Asphalt = 0.3ft. Concrete = 0.6ft.						
				<i>Terrace deposit</i> , orange - brown, f-c, clayey SAND with gravel, medium dense, moist, SC	7+8+4	18				
5		C2		Loose	6+7+8	18				
					3+4+3	4				
10		C1		<i>Terrace deposit</i> , gray, LEAN CLAY, micaceous, firm, moist, CL	2+3+4	18				33.5
				Bottom of Boring at 10.0 ft						

GROUND WATER LEVELS: NOT ENCOUNTERED DURING DRILLING NOT ENCOUNTERED UPON COMPLETION CAVED: <u>5.7</u> ft	SAMPLE TYPES: <input checked="" type="checkbox"/> Split Spoon
--	--

REMARKS:

THE STRATIFICATION LINES REPRESENT APPROXIMATE BOUNDARIES. THE TRANSITION MAY BE GRADUAL.

BOREHOLE/TEST PIT SEG. D&C LOGS.GPJ GEOCONCEPTS TEMPLATE 02-12-2015.GDT 4/26/16



PROJECT: Columbia Pike Multimodal Street Improvements		LOGGED BY: L. Pugh		BORING NUMBER: DB-8
LOCATION: Columbia Pike, Arlington, VA		DRILLING CONTRACTOR: Connelly & Associates, Inc.		
OWNER/CLIENT: Kimley-Horn & Associates, Inc.		DRILLER: R. Wilcher	DATES DRILLED: 2/12/15 - 2/12/15	
PROJECT NUMBER: 14189	GROUND SURFACE ELEVATION (ft): NOT SURVEYED	DRILLING METHOD: 2.25" H.S.A	OFFSET NOTES:	

DEPTH (ft)	SAMPLE TYPE	STRATUM	GRAPHIC	MATERIAL DESCRIPTION	SOIL						
					SPT BLOW COUNTS	REC (ft)	STANDARD PENETRATION TEST RESISTANCE (BPF)		MC (%)		
							20	40		60	80
				Asphalt = 0.3ft. Concrete = 0.4ft.							
				Terrace deposit, brown, f-c, clayey SAND, medium dense, moist, SC F-m, loose	7+8+8	18					
5		C2			6+4+6	18					
					3+4+4	4					
10		C1		Terrace deposit, gray, LEAN CLAY, micaceous, stiff, moist, CL	5+6+8	18					33.4
				Bottom of Boring at 10.0 ft							

GROUND WATER LEVELS: NOT ENCOUNTERED DURING DRILLING NOT ENCOUNTERED UPON COMPLETION CAVED: <u>5.0</u> ft	SAMPLE TYPES: <input checked="" type="checkbox"/> Split Spoon
--	--

REMARKS:

THE STRATIFICATION LINES REPRESENT APPROXIMATE BOUNDARIES. THE TRANSITION MAY BE GRADUAL.

BOREHOLE/TEST PIT SEG. D&C LOGS.GPJ GEOCONCEPTS TEMPLATE 02-12-2015.GDT 4/26/16



PROJECT: Columbia Pike Multimodal Street Improvements		LOGGED BY: L. Pugh		BORING NUMBER: DB-9
LOCATION: Columbia Pike, Arlington, VA		DRILLING CONTRACTOR: Connelly & Associates, Inc.		
OWNER/CLIENT: Kimley-Horn & Associates, Inc.		DRILLER: R. Wilcher	DATES DRILLED: 2/12/15 - 2/12/15	
PROJECT NUMBER: 14189	GROUND SURFACE ELEVATION (ft): NOT SURVEYED	DRILLING METHOD: 2.25" H.S.A	OFFSET NOTES:	

DEPTH (ft)	SAMPLE TYPE	STRATUM	GRAPHIC	MATERIAL DESCRIPTION	SOIL						
					SPT BLOW COUNTS	REC (ft)	STANDARD PENETRATION TEST RESISTANCE (BPF)		MC (%)		
							20	40	60	80	
				Asphalt = 0.2ft. Concrete = 0.9ft.							
	X	C2		Terrace deposit, orange - brown, f, clayey SAND, medium dense, moist, SC	5+7+8	18					11.3
	X	C1		Terrace deposit, orange - brown, f, LEAN CLAY with sand, very stiff, moist, CL	4+6+10	18					18.7
5	X	C2		Terrace deposit, orange - brown, f, clayey SAND, medium dense, moist, SC	12+12+13	18					15.6
10	X	C1		Terrace deposit, orange - brown, f-m, LEAN CLAY with sand, firm, moist, CL	13+3+2	18					29.4
				Bottom of Boring at 10.0 ft							

GROUND WATER LEVELS: NOT ENCOUNTERED DURING DRILLING NOT ENCOUNTERED UPON COMPLETION CAVED: <u>5.4</u> ft	SAMPLE TYPES: <input checked="" type="checkbox"/> Split Spoon
--	--

REMARKS:

THE STRATIFICATION LINES REPRESENT APPROXIMATE BOUNDARIES. THE TRANSITION MAY BE GRADUAL.

BOREHOLE/TEST PIT SEG. D&C LOGS.GPJ GEOCONCEPTS TEMPLATE 02-12-2015.GDT 4/26/16

PROJECT: Columbia Pike Multimodal Street Improvements		LOGGED BY: L. Pugh	BORING NUMBER: DB-10
LOCATION: Columbia Pike, Arlington , VA		DRILLING CONTRACTOR: Connelly & Associates, Inc.	
OWNER/CLIENT: Kimley-Horn & Associates, Inc.		DRILLER: T. Chew	DATES DRILLED: 2/18/15 - 2/18/15
PROJECT NUMBER: 14189	GROUND SURFACE ELEVATION (ft): NOT SURVEYED	DRILLING METHOD: 2.25" H.S.A	OFFSET NOTES:

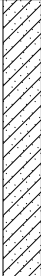
DEPTH (ft)	SAMPLE TYPE	STRATUM	GRAPHIC	MATERIAL DESCRIPTION	SOIL					
					SPT BLOW COUNTS	REC (ft)	STANDARD PENETRATION TEST RESISTANCE (BPF)			MC (%)
							20	40	60	
				Asphalt = 0.3ft.						
		C1		Concrete = 0.7ft.						
				<i>Terrace deposit, orange - brown, LEAN CLAY, firm, moist, CL</i>	5+3+3	18				
				<i>Terrace deposit, orange - brown, clayey SAND, medium dense, moist, SC</i>	4+6+7	18				16.1
5		C2			7+9+12	18				
10				Bottom of Boring at 10.0 ft	8+9+12	18				

GROUND WATER LEVELS: NOT ENCOUNTERED DURING DRILLING NOT ENCOUNTERED UPON COMPLETION CAVED: <u>5.4</u> ft	SAMPLE TYPES: <input checked="" type="checkbox"/> Split Spoon
--	--

REMARKS: Bulk sample from 0' to 5'

BOREHOLE/TEST PIT SEG. D&C LOGS.GPJ GEOCONCEPTS TEMPLATE 02-12-2015.GDT 4/26/16

THE STRATIFICATION LINES REPRESENT APPROXIMATE BOUNDARIES. THE TRANSITION MAY BE GRADUAL.



PROJECT: Columbia Pike Multimodal Street Improvements		LOGGED BY: L. Pugh		BORING NUMBER: DB-11
LOCATION: Columbia Pike, Arlington, VA		DRILLING CONTRACTOR: Connelly & Associates, Inc.		
OWNER/CLIENT: Kimley-Horn & Associates, Inc.		DRILLER: R. Wilcher	DATES DRILLED: 2/11/15 - 2/11/15	
PROJECT NUMBER: 14189	GROUND SURFACE ELEVATION (ft): NOT SURVEYED	DRILLING METHOD: 2.25" H.S.A	OFFSET NOTES:	

DEPTH (ft)	SAMPLE TYPE	STRATUM	GRAPHIC	MATERIAL DESCRIPTION	SOIL						
					SPT BLOW COUNTS	REC (ft)	STANDARD PENETRATION TEST RESISTANCE (BPF)		MC (%)		
							20	40		60	80
				Asphalt = 0.3ft. Concrete = 0.6ft.							
		C1		Terrace deposit, brown, f-m, LEAN CLAY with sand, hard, moist, CL Firm	13+27+12	18					13.3
5		C2		Terrace deposit, brown, f, clayey SAND, medium dense, moist, SC	11+4+3	0					
				Orange - brown, f-c, dense	6+8+7	18					
10				Bottom of Boring at 10.0 ft	19+16+15	18					

GROUND WATER LEVELS: NOT ENCOUNTERED DURING DRILLING NOT ENCOUNTERED UPON COMPLETION CAVED: <u>5.0</u> ft	SAMPLE TYPES: <input checked="" type="checkbox"/> Split Spoon
--	--

REMARKS:

THE STRATIFICATION LINES REPRESENT APPROXIMATE BOUNDARIES. THE TRANSITION MAY BE GRADUAL.

BOREHOLE/TEST PIT SEG. D&C LOGS.GPJ GEOCONCEPTS TEMPLATE 02-12-2015.GDT 4/22/16

PROJECT: Columbia Pike Multimodal Street Improvements		LOGGED BY: L. Pugh	BORING NUMBER: FRW-1
LOCATION: Columbia Pike, Arlington, VA		DRILLING CONTRACTOR: Connelly & Associates, Inc.	
OWNER/CLIENT: Kimley-Horn & Associates, Inc.		DRILLER: T. Chew	DATES DRILLED: 2/4/15 - 2/4/15
PROJECT NUMBER: 14189	GROUND SURFACE ELEVATION (ft): NOT SURVEYED	DRILLING METHOD: 2.25" H.S.A	OFFSET NOTES:

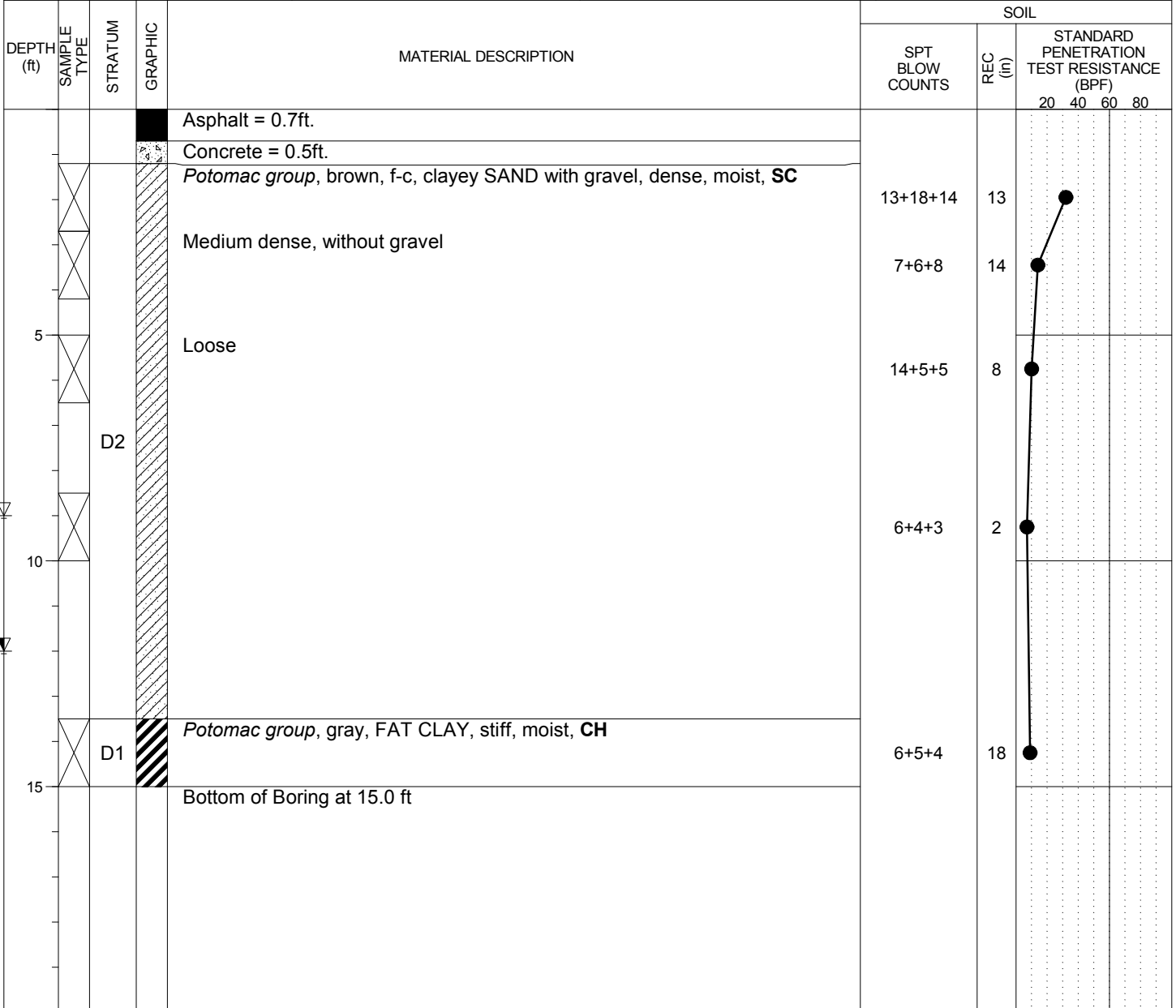

GROUND WATER LEVELS: ▽ ENCOUNTERED: <u>9.0</u> ft ▽ UPON COMPLETION: <u>12.0</u> ft CAVED: <u>13.0</u> ft	SAMPLE TYPES: <input checked="" type="checkbox"/> Split Spoon
--	--

REMARKS:

THE STRATIFICATION LINES REPRESENT APPROXIMATE BOUNDARIES. THE TRANSITION MAY BE GRADUAL.

BOREHOLE/TEST PIT SEG. F LOGS.GPJ GEOCONCEPTS TEMPLATE 02-12-2015.GDT 4/22/16



PROJECT: Columbia Pike Multimodal Street Improvements		LOGGED BY: L. Pugh	BORING NUMBER: FRW-2
LOCATION: Columbia Pike, Arlington, VA		DRILLING CONTRACTOR: Connelly & Associates, Inc.	
OWNER/CLIENT: Kimley-Horn & Associates, Inc.		DRILLER: T. Chew	DATES DRILLED: 2/4/15 - 2/4/15
PROJECT NUMBER: 14189	GROUND SURFACE ELEVATION (ft): NOT SURVEYED	DRILLING METHOD: 2.25" H.S.A	OFFSET NOTES:

DEPTH (ft)	SAMPLE TYPE	STRATUM	GRAPHIC	MATERIAL DESCRIPTION	SOIL		
					SPT BLOW COUNTS	REC (ft)	STANDARD PENETRATION TEST RESISTANCE (BPF) 20 40 60 80
				Asphalt = 0.7ft.			
				Concrete = 0.6ft.			
				<i>Potomac group</i> , brown, f-c, clayey SAND with gravel, dense, moist, SC			
				Medium dense	12+20+17	16	
				Gray, micaceous, loose	16+12+7	14	
5				Very loose	5+5+4	11	
		D2					
10					3+2+2	10	
				<i>Potomac group</i> , orange - brown, f-c, POORLY GRADED SAND with clay, medium dense, moist, SP-SC			
15				Bottom of Boring at 15.0 ft	5+6+10	18	

GROUND WATER LEVELS: NOT ENCOUNTERED DURING DRILLING NOT ENCOUNTERED UPON COMPLETION CAVED: <u>8.0</u> ft	SAMPLE TYPES: <input checked="" type="checkbox"/> Split Spoon
--	--

REMARKS:

THE STRATIFICATION LINES REPRESENT APPROXIMATE BOUNDARIES. THE TRANSITION MAY BE GRADUAL.

BOREHOLE/TEST PIT SEG. F LOGS.GPJ GEOCONCEPTS TEMPLATE 02-12-2015.GDT 4/22/16



PROJECT: Columbia Pike Multimodal Street Improvements		LOGGED BY: L. Pugh	BORING NUMBER: FRW-3
LOCATION: Columbia Pike, Arlington, VA		DRILLING CONTRACTOR: Connelly & Associates, Inc.	
OWNER/CLIENT: Kimley-Horn & Associates, Inc.		DRILLER: T. Chew	DATES DRILLED: 2/4/15 - 2/4/15
PROJECT NUMBER: 14189	GROUND SURFACE ELEVATION (ft): NOT SURVEYED	DRILLING METHOD: 2.25" H.S.A	OFFSET NOTES:

DEPTH (ft)	SAMPLE TYPE	STRATUM	GRAPHIC	MATERIAL DESCRIPTION	SOIL					
					SPT BLOW COUNTS	REC (ft)	STANDARD PENETRATION TEST RESISTANCE (BPF)			
							20	40	60	80
				Asphalt = 0.7ft.						
				Concrete = 0.6ft.						
				Potomac group, brown, f-c, clayey SAND with gravel, dense, moist, SC						
				Medium dense, moist	15+21+18	18				
					15+10+5	18				
5		D2			20+16+10	15				
				Potomac group, brown, f-c, sandy FAT CLAY with gravel, soft, moist, CH						
10					1+2+2	14				
		D1								
				Firm, moist						
15				Bottom of Boring at 15.0 ft	3+4+4	3				

GROUND WATER LEVELS: NOT ENCOUNTERED DURING DRILLING NOT ENCOUNTERED UPON COMPLETION CAVED: <u>7.5</u> ft	SAMPLE TYPES: <input checked="" type="checkbox"/> Split Spoon
--	--

REMARKS:

THE STRATIFICATION LINES REPRESENT APPROXIMATE BOUNDARIES. THE TRANSITION MAY BE GRADUAL.

BOREHOLE/TEST PIT SEG. F LOGS.GPJ GEOCONCEPTS TEMPLATE 02-12-2015.GDT 4/22/16



PROJECT: Columbia Pike Multimodal Street Improvements		LOGGED BY: L. Pugh	BORING NUMBER: FRW-4
LOCATION: Columbia Pike, Arlington, VA		DRILLING CONTRACTOR: Connelly & Associates, Inc.	
OWNER/CLIENT: Kimley-Horn & Associates, Inc.		DRILLER: T. Chew	DATES DRILLED: 2/4/15 - 2/4/15
PROJECT NUMBER: 14189	GROUND SURFACE ELEVATION (ft): NOT SURVEYED	DRILLING METHOD: 2.25" H.S.A	OFFSET NOTES:

DEPTH (ft)	SAMPLE TYPE	STRATUM	GRAPHIC	MATERIAL DESCRIPTION	SOIL		
					SPT BLOW COUNTS	REC (ft)	STANDARD PENETRATION TEST RESISTANCE (BPF) 20 40 60 80
				Asphalt = 0.7ft.			
				Concrete = 0.6ft.			
				<i>Potomac group</i> , brown, f-c, clayey SAND, loose, moist, SC	12+4+3	6	
		D2			5+4+4	5	
5				<i>Potomac group</i> , orange brown and gray, f, sandy LEAN CLAY with gravel, stiff, moist, CL	4+4+5	6	
				<i>Potomac group</i> , light brown, LEAN CLAY, micaceous, very stiff, moist, CL	4+7+9	18	
10		D1					
				Gray	8+10+14	18	
15				Bottom of Boring at 15.0 ft			

GROUND WATER LEVELS: NOT ENCOUNTERED DURING DRILLING NOT ENCOUNTERED UPON COMPLETION CAVED: <u>7.0</u> ft	SAMPLE TYPES: <input checked="" type="checkbox"/> Split Spoon
--	--

REMARKS:

BOREHOLE/TEST PIT SEG. F LOGS.GPJ GEOCONCEPTS TEMPLATE 02-12-2015.GDT 4/22/16

THE STRATIFICATION LINES REPRESENT APPROXIMATE BOUNDARIES. THE TRANSITION MAY BE GRADUAL.

PROJECT: Columbia Pike Multimodal Street Improvements		LOGGED BY: L. Pugh	BORING NUMBER: FRW-5
LOCATION: Columbia Pike, Arlington , VA		DRILLING CONTRACTOR: Connelly & Associates, Inc.	
OWNER/CLIENT: Kimley-Horn & Associates, Inc.		DRILLER: T. Chew	DATES DRILLED: 2/5/15 - 2/5/15
PROJECT NUMBER: 14189	GROUND SURFACE ELEVATION (ft): NOT SURVEYED	DRILLING METHOD: 2.25" H.S.A	OFFSET NOTES:

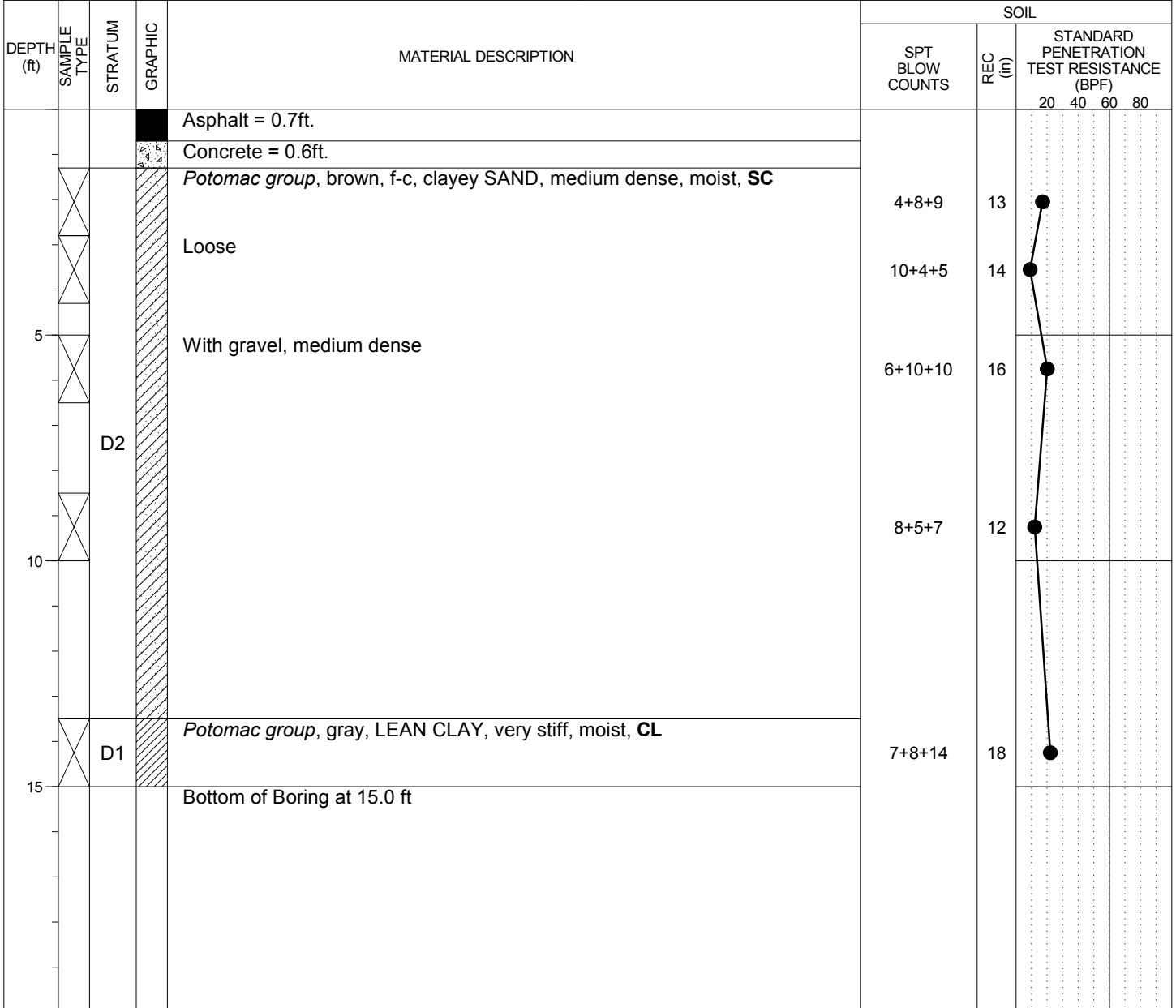





GROUND WATER LEVELS: NOT ENCOUNTERED DURING DRILLING NOT ENCOUNTERED UPON COMPLETION CAVED: <u>8.0</u> ft	SAMPLE TYPES: <input checked="" type="checkbox"/> Split Spoon
--	--

REMARKS:

THE STRATIFICATION LINES REPRESENT APPROXIMATE BOUNDARIES. THE TRANSITION MAY BE GRADUAL.

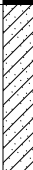
BOREHOLE/TEST PIT SEG. F LOGS.GPJ GEOCONCEPTS TEMPLATE 02-12-2015.GDT 4/22/16

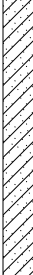
PROJECT: Columbia Pike Multimodal Street Improvements		LOGGED BY: L. Pugh	BORING NUMBER: FRW-6
LOCATION: Columbia Pike, Arlington, VA		DRILLING CONTRACTOR: Connelly & Associates, Inc.	
OWNER/CLIENT: Kimley-Horn & Associates, Inc.		DRILLER: T. Chew	DATES DRILLED: 2/5/15 - 2/5/15
PROJECT NUMBER: 14189	GROUND SURFACE ELEVATION (ft): NOT SURVEYED	DRILLING METHOD: 2.25" H.S.A	OFFSET NOTES:

DEPTH (ft)	SAMPLE TYPE	STRATUM	GRAPHIC	MATERIAL DESCRIPTION	SOIL					
					SPT BLOW COUNTS	REC (ft)	STANDARD PENETRATION TEST RESISTANCE (BPF)			MC (%)
					20	40	60	80		
				Asphalt = 1ft. Concrete = 0.5ft.						
		D2		Potomac group, brown, f-c, clayey SAND with gravel, medium dense, moist, SC	11+8+7	4				17.8
		D2			10+9+5	5				14.0
5		D1		Potomac group, gray, FAT CLAY, stiff, moist, CH	4+6+7	18				37.2
		D2		Potomac group, orange - brown, f-m, clayey SAND, medium dense, moist, SC	5+7+12	18				22.6
10		D2		Potomac group, light gray, f-c, POORLY GRADED SAND with clay, medium dense, moist, SP-SC	7+7+10	18				13.0
15				Bottom of Boring at 15.0 ft						

GROUND WATER LEVELS: NOT ENCOUNTERED DURING DRILLING NOT ENCOUNTERED UPON COMPLETION CAVED: <u>8.0</u> ft	SAMPLE TYPES:  Split Spoon
--	--

REMARKS:

THE STRATIFICATION LINES REPRESENT APPROXIMATE BOUNDARIES. THE TRANSITION MAY BE GRADUAL.

BOREHOLE/TEST PIT SEG. F LOGS.GPJ GEOCONCEPTS TEMPLATE 02-12-2015.GDT 4/22/16



PROJECT: Columbia Pike Multimodal Street Improvements		LOGGED BY: L. Pugh		BORING NUMBER: FRW-7
LOCATION: Columbia Pike, Arlington , VA		DRILLING CONTRACTOR: Connelly & Associates, Inc.		
OWNER/CLIENT: Kimley-Horn & Associates, Inc.		DRILLER: T. Chew	DATES DRILLED: 2/5/15 - 2/5/15	
PROJECT NUMBER: 14189	GROUND SURFACE ELEVATION (ft): NOT SURVEYED	DRILLING METHOD: 2.25" H.S.A	OFFSET NOTES:	

DEPTH (ft)	SAMPLE TYPE	STRATIUM	GRAPHIC	MATERIAL DESCRIPTION	SOIL		
					SPT BLOW COUNTS	REC (ft)	STANDARD PENETRATION TEST RESISTANCE (BPF) 20 40 60 80
				Asphalt = 0.5ft.			
				Concrete = 0.5ft.			
				<i>Potomac group</i> , light brown, FAT CLAY, micaceous, stiff, moist, CH	7+5+4	14	
		D1		Very stiff, moist	4+7+10	18	
5				<i>Potomac group</i> , orange - brown, f-m, clayey SAND, medium dense, moist, SC	7+9+12	17	
				<i>Potomac group</i> , light gray, f-c, POORLY GRADED SAND with clay, medium dense, moist, SP-SC	10+7+8	18	
10		D2					
					8+10+11	14	
15				Bottom of Boring at 15.0 ft			

GROUND WATER LEVELS: NOT ENCOUNTERED DURING DRILLING NOT ENCOUNTERED UPON COMPLETION CAVED: <u>7.5</u> ft	SAMPLE TYPES: Split Spoon
--	------------------------------

REMARKS:

THE STRATIFICATION LINES REPRESENT APPROXIMATE BOUNDARIES. THE TRANSITION MAY BE GRADUAL.

BOREHOLE/TEST PIT SEG. F LOGS.GPJ GEOCONCEPTS TEMPLATE 02-12-2015.GDT 4/22/16



PROJECT: Columbia Pike Multimodal Street Improvements		LOGGED BY: L. Pugh	BORING NUMBER: FRW-8
LOCATION: Columbia Pike, Arlington, VA		DRILLING CONTRACTOR: Connelly & Associates, Inc.	
OWNER/CLIENT: Kimley-Horn & Associates, Inc.		DRILLER: T. Chew	DATES DRILLED: 2/5/15 - 2/5/15
PROJECT NUMBER: 14189	GROUND SURFACE ELEVATION (ft): NOT SURVEYED	DRILLING METHOD: 2.25" H.S.A	OFFSET NOTES:

DEPTH (ft)	SAMPLE TYPE	STRATUM	GRAPHIC	MATERIAL DESCRIPTION	SOIL		
					SPT BLOW COUNTS	REC (ft)	STANDARD PENETRATION TEST RESISTANCE (BPF) 20 40 60 80
				Asphalt = 0.7ft.			
				Concrete = 0.6ft.			
				Potomac group, brown, f-c, clayey SAND, medium dense, moist, SC	8+14+6	4	
				White	5+5+7	18	
5					4+5+6	18	
		D2			4+7+8	18	
10							
				Potomac group, gray and orange brown, f-c, sandy LEAN CLAY, very stiff, moist, CL	5+9+11	18	
15		D1					
				Bottom of Boring at 15.0 ft			

GROUND WATER LEVELS: <input checked="" type="checkbox"/> ENCOUNTERED: <u>5.5</u> ft NOT ENCOUNTERED UPON COMPLETION CAVED: <u>7.4</u> ft	SAMPLE TYPES: <input checked="" type="checkbox"/> Split Spoon
---	--

REMARKS:

THE STRATIFICATION LINES REPRESENT APPROXIMATE BOUNDARIES. THE TRANSITION MAY BE GRADUAL.

BOREHOLE/TEST PIT SEG. F LOGS.GPJ GEOCONCEPTS TEMPLATE 02-12-2015.GDT 4/22/16

PROJECT: Columbia Pike Multimodal Street Improvements		LOGGED BY: L. Pugh	BORING NUMBER: FB-1
LOCATION: Columbia Pike, Arlington , VA		DRILLING CONTRACTOR: Connelly & Associates, Inc.	
OWNER/CLIENT: Kimley-Horn & Associates, Inc.		DRILLER: R. Wilcher	DATES DRILLED: 2/10/15 - 2/10/15
PROJECT NUMBER: 14189	GROUND SURFACE ELEVATION (ft): NOT SURVEYED	DRILLING METHOD: 2.25" H.S.A	OFFSET NOTES:

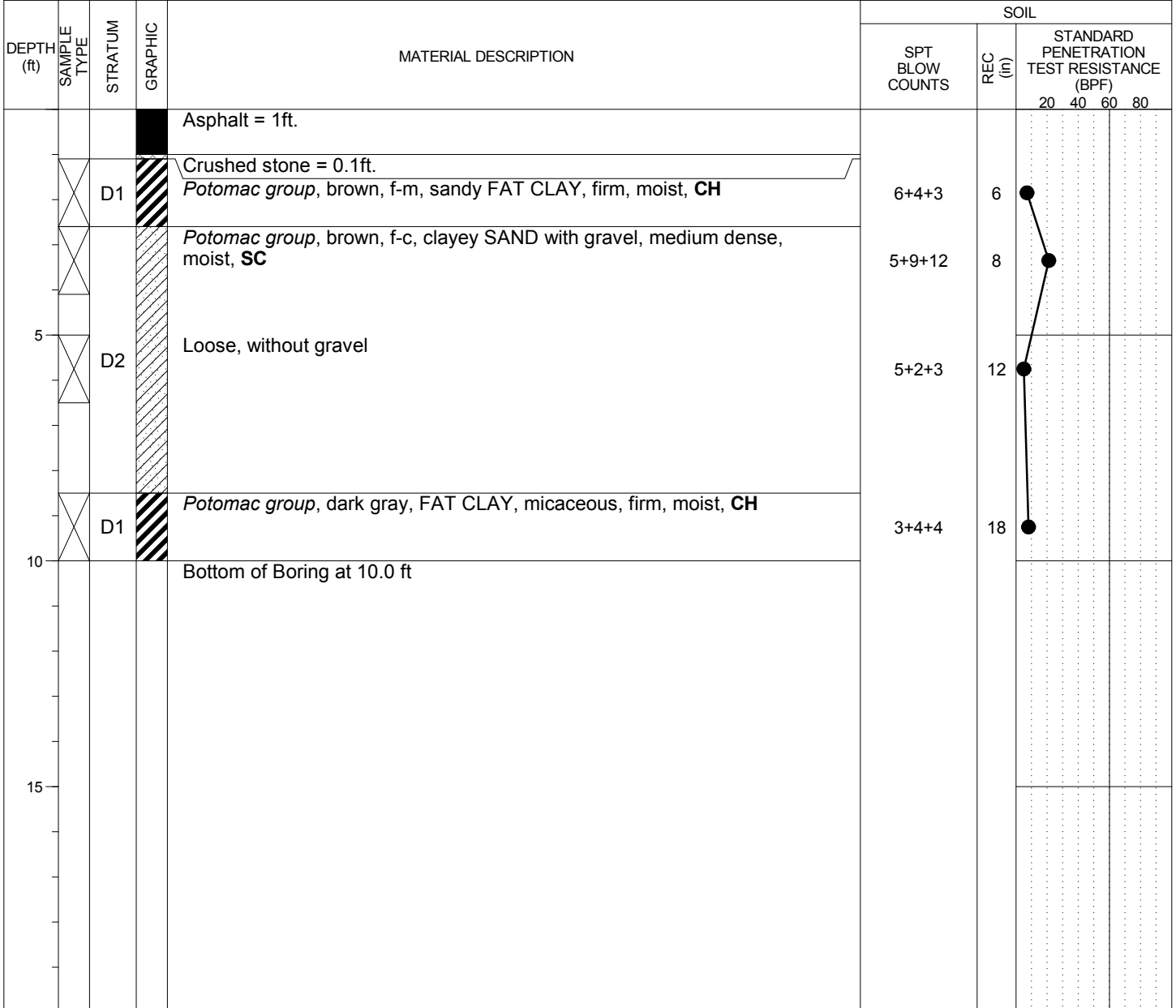

GROUND WATER LEVELS: NOT ENCOUNTERED DURING DRILLING NOT ENCOUNTERED UPON COMPLETION CAVED: <u>5.5</u> ft	SAMPLE TYPES: <input checked="" type="checkbox"/> Split Spoon
--	--

REMARKS:

THE STRATIFICATION LINES REPRESENT APPROXIMATE BOUNDARIES. THE TRANSITION MAY BE GRADUAL.

BOREHOLE/TEST PIT SEG. F LOGS.GPJ GEOCONCEPTS TEMPLATE 02-12-2015.GDT 4/22/16



PROJECT: Columbia Pike Multimodal Street Improvements		LOGGED BY: L. Pugh		BORING NUMBER: FB-2
LOCATION: Columbia Pike, Arlington, VA		DRILLING CONTRACTOR: Connelly & Associates, Inc.		
OWNER/CLIENT: Kimley-Horn & Associates, Inc.		DRILLER: T. Chew		DATES DRILLED: 2/4/15 - 2/4/15
PROJECT NUMBER: 14189	GROUND SURFACE ELEVATION (ft): NOT SURVEYED	DRILLING METHOD: 2.25" H.S.A		OFFSET NOTES:

DEPTH (ft)	SAMPLE TYPE	STRATUM	GRAPHIC	MATERIAL DESCRIPTION	SOIL						
					SPT BLOW COUNTS	REC (ft)	STANDARD PENETRATION TEST RESISTANCE (BPF)			MC (%)	
							20	40	60		80
				Asphalt = 0.6ft.							
				Concrete = 0.9ft.							
				<i>Potomac group</i> , brown, f-c, clayey SAND with gravel, dense, moist, SC	12+18+15	17					6.2
				<i>Potomac group</i> , dark gray, f-m, silty SAND, micaceous, medium dense, moist, SM	6+7+9	8					
5		D2		<i>Potomac group</i> , brown, f-c, clayey SAND with gravel, medium dense, moist, SC	9+8+7	9					
				<i>Potomac group</i> , gray, FAT CLAY, firm, moist, CH	2+3+3	14					
10				Bottom of Boring at 10.0 ft							

GROUND WATER LEVELS: NOT ENCOUNTERED DURING DRILLING NOT ENCOUNTERED UPON COMPLETION CAVED: <u>6.0</u> ft	SAMPLE TYPES: <input checked="" type="checkbox"/> Split Spoon
--	--

REMARKS: Bulk sample collected from 0.0' to 5.0'

BOREHOLE/TEST PIT SEG. F LOGS.GPJ GEOCONCEPTS TEMPLATE 02-12-2015.GDT 4/22/16



PROJECT: Columbia Pike Multimodal Street Improvements		LOGGED BY: L. Pugh		BORING NUMBER: FB-3
LOCATION: Columbia Pike, Arlington, VA		DRILLING CONTRACTOR: Connelly & Associates, Inc.		
OWNER/CLIENT: Kimley-Horn & Associates, Inc.		DRILLER: R. Wilcher	DATES DRILLED: 2/9/15 - 2/9/15	
PROJECT NUMBER: 14189	GROUND SURFACE ELEVATION (ft): NOT SURVEYED	DRILLING METHOD: 2.25" H.S.A	OFFSET NOTES:	

DEPTH (ft)	SAMPLE TYPE	STRATUM	GRAPHIC	MATERIAL DESCRIPTION	SOIL						
					SPT BLOW COUNTS	REC (ft)	STANDARD PENETRATION TEST RESISTANCE (BPF)		MC (%)		
							20	40		60	80
				Asphalt = 0.7ft.							
				Crushed stone = 0.1ft.							
	D2			<i>Potomac group</i> , brown and black, f-c, clayey SAND with gravel, medium dense, moist, SC	10+9+7	18					
	D1			<i>Potomac group</i> , gray, FAT CLAY, micaceous, stiff, moist, CH	5+5+7	18					37.5
5	D2			<i>Potomac group</i> , orange - brown, clayey SAND, medium dense, moist, SC	8+8+4	4					
	D1			<i>Potomac group</i> , gray, FAT CLAY with sand, firm, moist, CH	3+4+4	6					
10				Bottom of Boring at 10.0 ft							

GROUND WATER LEVELS: NOT ENCOUNTERED DURING DRILLING NOT ENCOUNTERED UPON COMPLETION CAVED: <u>5.5</u> ft	SAMPLE TYPES: <input checked="" type="checkbox"/> Split Spoon
--	--

REMARKS:

THE STRATIFICATION LINES REPRESENT APPROXIMATE BOUNDARIES. THE TRANSITION MAY BE GRADUAL.

BOREHOLE/TEST PIT SEG. F LOGS.GPJ GEOCONCEPTS TEMPLATE 02-12-2015.GDT 4/22/16

PROJECT: Columbia Pike Multimodal Street Improvements		LOGGED BY: L. Pugh	BORING NUMBER: FB-4
LOCATION: Columbia Pike, Arlington, VA		DRILLING CONTRACTOR: Connelly & Associates, Inc.	
OWNER/CLIENT: Kimley-Horn & Associates, Inc.		DRILLER: T. Chew	DATES DRILLED: 2/5/15 - 2/5/15
PROJECT NUMBER: 14189	GROUND SURFACE ELEVATION (ft): NOT SURVEYED	DRILLING METHOD: 2.25" H.S.A	OFFSET NOTES:

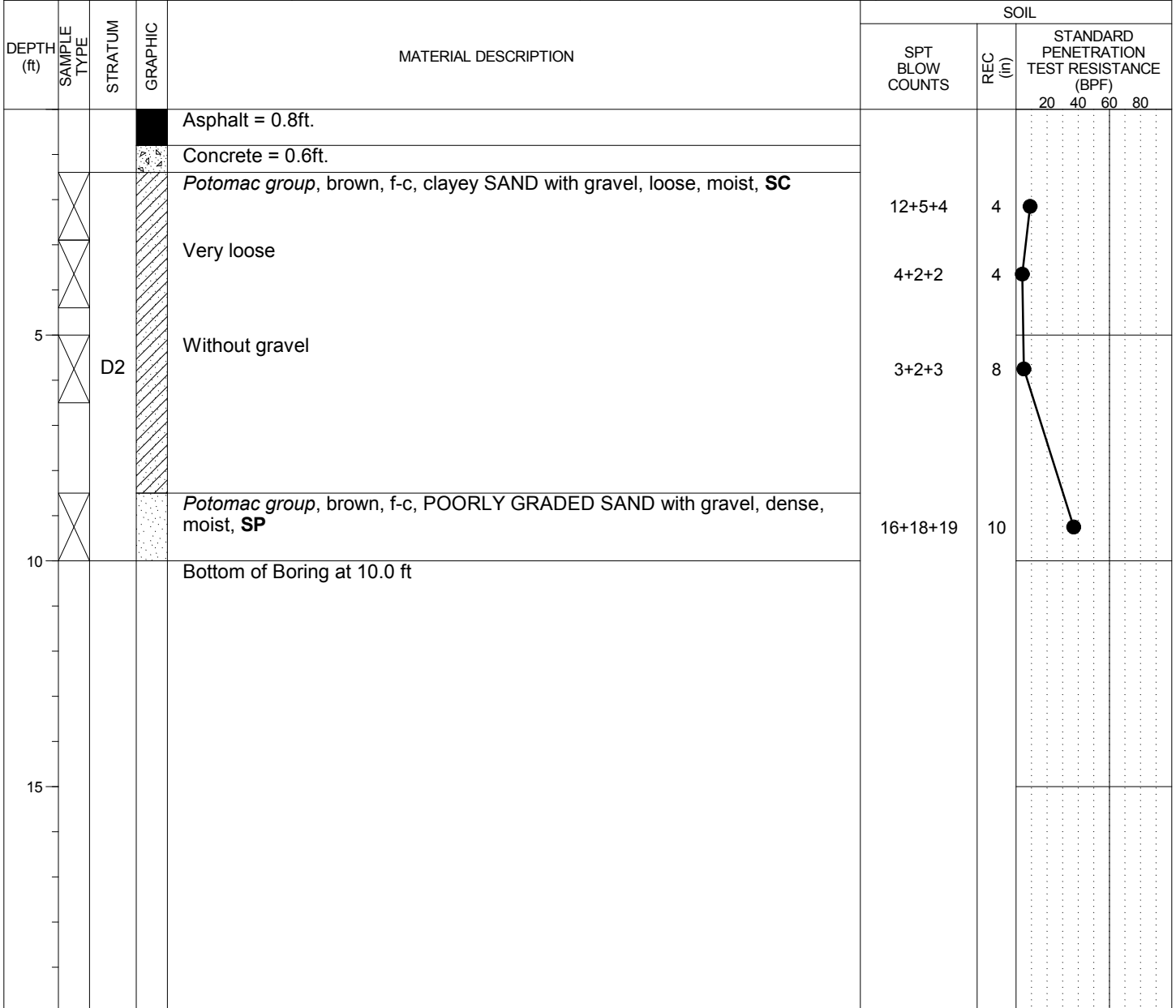

GROUND WATER LEVELS: NOT ENCOUNTERED DURING DRILLING NOT ENCOUNTERED UPON COMPLETION CAVED: <u>6.0</u> ft	SAMPLE TYPES: <input checked="" type="checkbox"/> Split Spoon
--	--

REMARKS:

THE STRATIFICATION LINES REPRESENT APPROXIMATE BOUNDARIES. THE TRANSITION MAY BE GRADUAL.

BOREHOLE/TEST PIT SEG. F LOGS.GPJ GEOCONCEPTS TEMPLATE 02-12-2015.GDT 4/22/16

PROJECT: Columbia Pike Multimodal Street Improvements		LOGGED BY: L. Pugh	BORING NUMBER: FB-5
LOCATION: Columbia Pike, Arlington , VA		DRILLING CONTRACTOR: Connelly & Associates, Inc.	
OWNER/CLIENT: Kimley-Horn & Associates, Inc.		DRILLER: R. Wilcher	DATES DRILLED: 2/9/15 - 2/9/15
PROJECT NUMBER: 14189	GROUND SURFACE ELEVATION (ft): NOT SURVEYED	DRILLING METHOD: 2.25" H.S.A	OFFSET NOTES:

DEPTH (ft)	SAMPLE TYPE	STRATUM	GRAPHIC	MATERIAL DESCRIPTION	SOIL		
					SPT BLOW COUNTS	REC (ft)	STANDARD PENETRATION TEST RESISTANCE (BPF) 20 40 60 80
				Asphalt = 0.9ft.			
				Crushed stone = 0.1ft.			
				<i>Potomac group</i> , orange - brown, f-c, sandy FAT CLAY, stiff, moist, CH	2+4+5	18	
				Brown, with gravel			
5		D1		Firm	2+5+7	12	
				<i>Potomac group</i> , gray, FAT CLAY, micaceous, stiff, moist, CH	2+3+5	10	
10				Bottom of Boring at 10.0 ft	4+4+6	18	

GROUND WATER LEVELS: NOT ENCOUNTERED DURING DRILLING NOT ENCOUNTERED UPON COMPLETION CAVED: <u>4.3</u> ft	SAMPLE TYPES: <input checked="" type="checkbox"/> Split Spoon
--	--

REMARKS:

THE STRATIFICATION LINES REPRESENT APPROXIMATE BOUNDARIES. THE TRANSITION MAY BE GRADUAL.



PROJECT: Columbia Pike Multimodal Street Improvements		LOGGED BY: L. Pugh	BORING NUMBER: FB-6
LOCATION: Columbia Pike, Arlington , VA		DRILLING CONTRACTOR: Connelly & Associates, Inc.	
OWNER/CLIENT: Kimley-Horn & Associates, Inc.		DRILLER: T. Chew	DATES DRILLED: 2/5/15 - 2/5/15
PROJECT NUMBER: 14189	GROUND SURFACE ELEVATION (ft): NOT SURVEYED	DRILLING METHOD: 2.25" H.S.A	OFFSET NOTES:

DEPTH (ft)	SAMPLE TYPE	STRATUM	GRAPHIC	MATERIAL DESCRIPTION	SOIL		
					SPT BLOW COUNTS	REC (ft)	STANDARD PENETRATION TEST RESISTANCE (BPF) 20 40 60 80
				Asphalt = 0.6ft.			
				Concrete = 0.6ft.			
				<i>Potomac group</i> , light brown, f-m, clayey SAND, medium dense, moist, SC	5+8+6	18	●
					4+5+7	18	●
5		D2			9+10+8	6	●
10					4+6+9	18	●
				Bottom of Boring at 10.0 ft			

GROUND WATER LEVELS: NOT ENCOUNTERED DURING DRILLING NOT ENCOUNTERED UPON COMPLETION CAVED: <u>5.8</u> ft	SAMPLE TYPES: <input checked="" type="checkbox"/> Split Spoon
--	--

REMARKS:

THE STRATIFICATION LINES REPRESENT APPROXIMATE BOUNDARIES. THE TRANSITION MAY BE GRADUAL.

BOREHOLE/TEST PIT SEG. F LOGS.GPJ GEOCONCEPTS TEMPLATE 02-12-2015.GDT 4/22/16

PROJECT: Columbia Pike Multimodal Street Improvements		LOGGED BY: L. Pugh	BORING NUMBER: FB-7
LOCATION: Columbia Pike, Arlington , VA		DRILLING CONTRACTOR: Connelly & Associates, Inc.	
OWNER/CLIENT: Kimley-Horn & Associates, Inc.		DRILLER: R. Wilcher	DATES DRILLED: 2/9/15 - 2/9/15
PROJECT NUMBER: 14189	GROUND SURFACE ELEVATION (ft): NOT SURVEYED	DRILLING METHOD: 2.25" H.S.A	OFFSET NOTES:

DEPTH (ft)	SAMPLE TYPE	STRATUM	GRAPHIC	MATERIAL DESCRIPTION	SOIL		
					SPT BLOW COUNTS	REC (ft)	STANDARD PENETRATION TEST RESISTANCE (BPF) 20 40 60 80
				Asphalt = 0.7ft.			
				Concrete = 0.5ft.			
				<i>Potomac group</i> , orange - brown, f, FAT CLAY with sand, micaceous, stiff, moist, CH With gravel	4+5+7	18	●
5		D1		Orange brown and gray, without gravel	5+7+7	18	●
				<i>Potomac group</i> , orange - brown, f-c, clayey SAND with gravel, dense, moist, SC	20+4+6	18	●
10		D2		Bottom of Boring at 10.0 ft	24+30+14	12	●

GROUND WATER LEVELS: NOT ENCOUNTERED DURING DRILLING NOT ENCOUNTERED UPON COMPLETION CAVED: <u>5.0</u> ft	SAMPLE TYPES: <input checked="" type="checkbox"/> Split Spoon
--	--

REMARKS:

THE STRATIFICATION LINES REPRESENT APPROXIMATE BOUNDARIES. THE TRANSITION MAY BE GRADUAL.



PROJECT: Columbia Pike Multimodal Street Improvements		LOGGED BY: L. Pugh		BORING NUMBER: FB-8
LOCATION: Columbia Pike, Arlington, VA		DRILLING CONTRACTOR: Connelly & Associates, Inc.		
OWNER/CLIENT: Kimley-Horn & Associates, Inc.		DRILLER: R. Wilcher	DATES DRILLED: 2/10/15 - 2/10/15	
PROJECT NUMBER: 14189	GROUND SURFACE ELEVATION (ft): NOT SURVEYED	DRILLING METHOD: 2.25" H.S.A	OFFSET NOTES:	

DEPTH (ft)	SAMPLE TYPE	STRATUM	GRAPHIC	MATERIAL DESCRIPTION	SOIL					
					SPT BLOW COUNTS	REC (ft)	STANDARD PENETRATION TEST RESISTANCE (BPF) 20 40 60 80			MC (%)
				Asphalt = 0.6ft.						
				Concrete = 0.5ft.						
				Alluvial, brown, f-c, sandy FAT CLAY with gravel, very stiff, moist, CH	3+9+10	12	●			
				Alluvial, orange - brown, f-m, clayey SAND, medium dense, moist, SC	9+12+14	18	●			22.7
5		B			10+10+13	18	●			
10				Bottom of Boring at 10.0 ft	10+10+10	12	●			

GROUND WATER LEVELS: NOT ENCOUNTERED DURING DRILLING NOT ENCOUNTERED UPON COMPLETION CAVED: <u>5.3</u> ft	SAMPLE TYPES: <input checked="" type="checkbox"/> Split Spoon
--	--

REMARKS:
THE STRATIFICATION LINES REPRESENT APPROXIMATE BOUNDARIES. THE TRANSITION MAY BE GRADUAL.

BOREHOLE/TEST PIT SEG. F LOGS.GPJ GEOCONCEPTS TEMPLATE 02-12-2015.GDT 4/22/16



PROJECT: Columbia Pike Multimodal Street Improvements		LOGGED BY: L. Pugh	BORING NUMBER: FB-9
LOCATION: Columbia Pike, Arlington, VA		DRILLING CONTRACTOR: Connelly & Associates, Inc.	
OWNER/CLIENT: Kimley-Horn & Associates, Inc.		DRILLER: R. Wilcher	DATES DRILLED: 2/9/15 - 2/9/15
PROJECT NUMBER: 14189	GROUND SURFACE ELEVATION (ft): NOT SURVEYED	DRILLING METHOD: 2.25" H.S.A	OFFSET NOTES:

DEPTH (ft)	SAMPLE TYPE	STRATUM	GRAPHIC	MATERIAL DESCRIPTION	SOIL		
					SPT BLOW COUNTS	REC (ft)	STANDARD PENETRATION TEST RESISTANCE (BPF) 20 40 60 80
				Asphalt = 0.6ft.			
				Concrete = 0.6ft.			
				<i>Alluvial</i> , orange - brown, f-c, sandy LEAN CLAY, stiff, moist, CL			
				Very stiff	11+4+6	8	
				Wet	4+14+13	18	
5		B		Orange brown and gray	4+5+9	6	
10				Bottom of Boring at 10.0 ft	7+9+14	18	

GROUND WATER LEVELS: NOT ENCOUNTERED DURING DRILLING NOT ENCOUNTERED UPON COMPLETION CAVED: <u>6.2</u> ft	SAMPLE TYPES: <input checked="" type="checkbox"/> Split Spoon
--	--

REMARKS: Bulk sample collected from 0.0' to 5.0'

BOREHOLE/TEST PIT SEG. F LOGS.GPJ GEOCONCEPTS TEMPLATE 02-12-2015.GDT 4/22/16

THE STRATIFICATION LINES REPRESENT APPROXIMATE BOUNDARIES. THE TRANSITION MAY BE GRADUAL.



PROJECT: Columbia Pike Multimodal Street Improvements		LOGGED BY: L. Pugh		BORING NUMBER: FB-10
LOCATION: Columbia Pike, Arlington, VA		DRILLING CONTRACTOR: Connelly & Associates, Inc.		
OWNER/CLIENT: Kimley-Horn & Associates, Inc.		DRILLER: R. Wilcher	DATES DRILLED: 2/9/15 - 2/9/15	
PROJECT NUMBER: 14189	GROUND SURFACE ELEVATION (ft): NOT SURVEYED	DRILLING METHOD: 2.25" H.S.A	OFFSET NOTES:	

DEPTH (ft)	SAMPLE TYPE	STRATUM	GRAPHIC	MATERIAL DESCRIPTION	SOIL				
					SPT BLOW COUNTS	REC (ft)	STANDARD PENETRATION TEST RESISTANCE (BPF) 20 40 60 80		MC (%)
				Asphalt = 0.4ft.					
				Concrete = 0.6ft.					
				Alluvial, orange - brown, f-m, clayey SAND with gravel, medium dense, moist, SC	5+7+4	18			
				F-c	4+4+7	18			
5		B		Brown, very dense	43+37+23	18			
				Alluvial, gray, FAT CLAY, soft, moist, CH	1+1+1	2			36.7
10				Bottom of Boring at 10.0 ft					

GROUND WATER LEVELS: NOT ENCOUNTERED DURING DRILLING NOT ENCOUNTERED UPON COMPLETION CAVED: <u>5.5</u> ft	SAMPLE TYPES: <input checked="" type="checkbox"/> Split Spoon
--	--

REMARKS:

THE STRATIFICATION LINES REPRESENT APPROXIMATE BOUNDARIES. THE TRANSITION MAY BE GRADUAL.

BOREHOLE/TEST PIT SEG. F LOGS.GPJ GEOCONCEPTS TEMPLATE 02-12-2015.GDT 4/22/16



PROJECT: Columbia Pike Multimodal Street Improvements		LOGGED BY: L. Pugh	BORING NUMBER: FB-11
LOCATION: Columbia Pike, Arlington, VA		DRILLING CONTRACTOR: Connelly & Associates, Inc.	
OWNER/CLIENT: Kimley-Horn & Associates, Inc.		DRILLER: Z. Macomber	DATES DRILLED: 2/3/15 - 2/3/15
PROJECT NUMBER: 14189	GROUND SURFACE ELEVATION (ft): NOT SURVEYED	DRILLING METHOD: 2.25" H.S.A	OFFSET NOTES:

DEPTH (ft)	SAMPLE TYPE	STRATIUM	GRAPHIC	MATERIAL DESCRIPTION	SOIL					
					SPT BLOW COUNTS	REC (ft)	STANDARD PENETRATION TEST RESISTANCE (BPF)			
							20	40	60	80
				Asphalt = 0.3ft. Concrete = 0.6ft.						
		D1		Potomac group, orange brown and gray, f-m, sandy FAT CLAY with gravel, very stiff, moist, CH	3+9+10	17				
		D1			3+9+10	6				
5		D2		Potomac group, orange - brown, f-c, clayey SAND with gravel, medium dense, moist, SC	17+9+10	13				
		D1		Potomac group, gray, LEAN CLAY, very stiff, moist, CL	10+12+12	5				
10				Bottom of Boring at 10.0 ft						

GROUND WATER LEVELS: NOT ENCOUNTERED DURING DRILLING NOT ENCOUNTERED UPON COMPLETION CAVED: <u>5.0</u> ft	SAMPLE TYPES: <input checked="" type="checkbox"/> Split Spoon
--	--

REMARKS:

THE STRATIFICATION LINES REPRESENT APPROXIMATE BOUNDARIES. THE TRANSITION MAY BE GRADUAL.

BOREHOLE/TEST PIT SEG. F LOGS.GPJ GEOCONCEPTS TEMPLATE 02-12-2015.GDT 4/22/16



PROJECT: Columbia Pike Multimodal Street Improvements		LOGGED BY: L. Pugh		BORING NUMBER: FB-12
LOCATION: Columbia Pike, Arlington, VA		DRILLING CONTRACTOR: Connelly & Associates, Inc.		
OWNER/CLIENT: Kimley-Horn & Associates, Inc.		DRILLER: Z. Macomber	DATES DRILLED: 2/3/15 - 2/3/15	
PROJECT NUMBER: 14189	GROUND SURFACE ELEVATION (ft): NOT SURVEYED	DRILLING METHOD: 2.25" H.S.A	OFFSET NOTES:	

DEPTH (ft)	SAMPLE TYPE	STRATUM	GRAPHIC	MATERIAL DESCRIPTION	SPT BLOW COUNTS	REC (ft)	SOIL				MC (%)
							STANDARD PENETRATION TEST RESISTANCE (BPF)				
							20	40	60	80	
				Asphalt = 0.4ft.							
				Concrete = 0.6ft.							
		D1		Potomac group, light brown, FAT CLAY, stiff, moist, CH	4+7+7	18					34.9
				Potomac group, light brown, clayey SAND, medium dense, moist, SC	7+9+12	18					
5		D2			11+12+15	18					
10				Bottom of Boring at 10.0 ft	6+10+10	18					

GROUND WATER LEVELS: NOT ENCOUNTERED DURING DRILLING NOT ENCOUNTERED UPON COMPLETION CAVED: <u>5.5</u> ft	SAMPLE TYPES: <input checked="" type="checkbox"/> Split Spoon
--	--

REMARKS:
THE STRATIFICATION LINES REPRESENT APPROXIMATE BOUNDARIES. THE TRANSITION MAY BE GRADUAL.

BOREHOLE/TEST PIT SEG. F LOGS.GPJ GEOCONCEPTS TEMPLATE 02-12-2015.GDT 4/22/16



PROJECT: Columbia Pike Multimodal Street Improvements		LOGGED BY: L. Pugh	BORING NUMBER: FB-13
LOCATION: Columbia Pike, Arlington , VA		DRILLING CONTRACTOR: Connelly & Associates, Inc.	
OWNER/CLIENT: Kimley-Horn & Associates, Inc.		DRILLER: Z. Macomber	DATES DRILLED: 2/3/15 - 2/3/15
PROJECT NUMBER: 14189	GROUND SURFACE ELEVATION (ft): NOT SURVEYED	DRILLING METHOD: 2.25" H.S.A	OFFSET NOTES:

DEPTH (ft)	SAMPLE TYPE	STRATUM	GRAPHIC	MATERIAL DESCRIPTION	SOIL		
					SPT BLOW COUNTS	REC (ft)	STANDARD PENETRATION TEST RESISTANCE (BPF) 20 40 60 80
				Asphalt = 0.4ft.			
				Concrete = 0.6ft.			
	D2			Potomac group, brown, f-m, clayey SAND, medium dense, moist, SC	5+12+8	7	
				Potomac group, orange brown and gray, f, FAT CLAY with sand, micaceous, very stiff, moist, CH	6+12+18	18	
5				Gray			
	D1				7+12+17	18	
10				Bottom of Boring at 10.0 ft	8+11+11	18	

GROUND WATER LEVELS: NOT ENCOUNTERED DURING DRILLING NOT ENCOUNTERED UPON COMPLETION CAVED: <u>6.5</u> ft	SAMPLE TYPES: <input checked="" type="checkbox"/> Split Spoon
--	--

REMARKS:

THE STRATIFICATION LINES REPRESENT APPROXIMATE BOUNDARIES. THE TRANSITION MAY BE GRADUAL.

BOREHOLE/TEST PIT SEG. F LOGS.GPJ GEOCONCEPTS TEMPLATE 02-12-2015.GDT 4/22/16

PROJECT: Columbia Pike Multimodal Street Improvements		LOGGED BY: L. Pugh	BORING NUMBER: FB-14
LOCATION: Columbia Pike, Arlington , VA		DRILLING CONTRACTOR: Connelly & Associates, Inc.	
OWNER/CLIENT: Kimley-Horn & Associates, Inc.		DRILLER: Z. Macomber	DATES DRILLED: 2/3/15 - 2/3/15
PROJECT NUMBER: 14189	GROUND SURFACE ELEVATION (ft): NOT SURVEYED	DRILLING METHOD: 2.25" H.S.A	OFFSET NOTES:

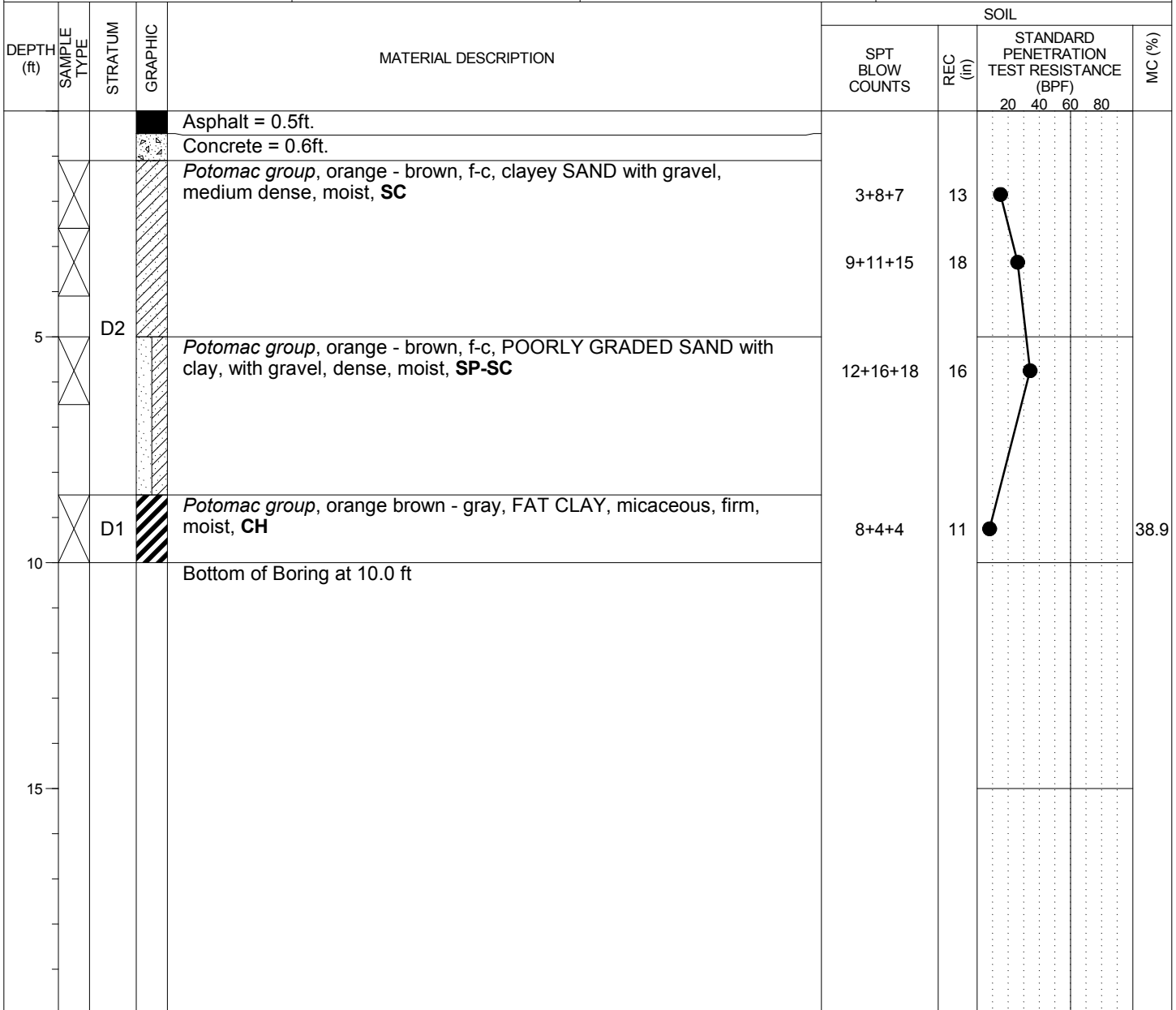

GROUND WATER LEVELS: NOT ENCOUNTERED DURING DRILLING NOT ENCOUNTERED UPON COMPLETION CAVED: <u>6.0</u> ft	SAMPLE TYPES: <input checked="" type="checkbox"/> Split Spoon
--	--

REMARKS:

THE STRATIFICATION LINES REPRESENT APPROXIMATE BOUNDARIES. THE TRANSITION MAY BE GRADUAL.



PROJECT: Columbia Pike Multimodal Street Improvements		LOGGED BY: L. Pugh	BORING NUMBER: FB-15
LOCATION: Columbia Pike, Arlington, VA		DRILLING CONTRACTOR: Connelly & Associates, Inc.	
OWNER/CLIENT: Kimley-Horn & Associates, Inc.		DRILLER: Z. Macomber	DATES DRILLED: 1/28/15 - 1/28/15
PROJECT NUMBER: 14189	GROUND SURFACE ELEVATION (ft): NOT SURVEYED	DRILLING METHOD: 2.25" H.S.A	OFFSET NOTES:

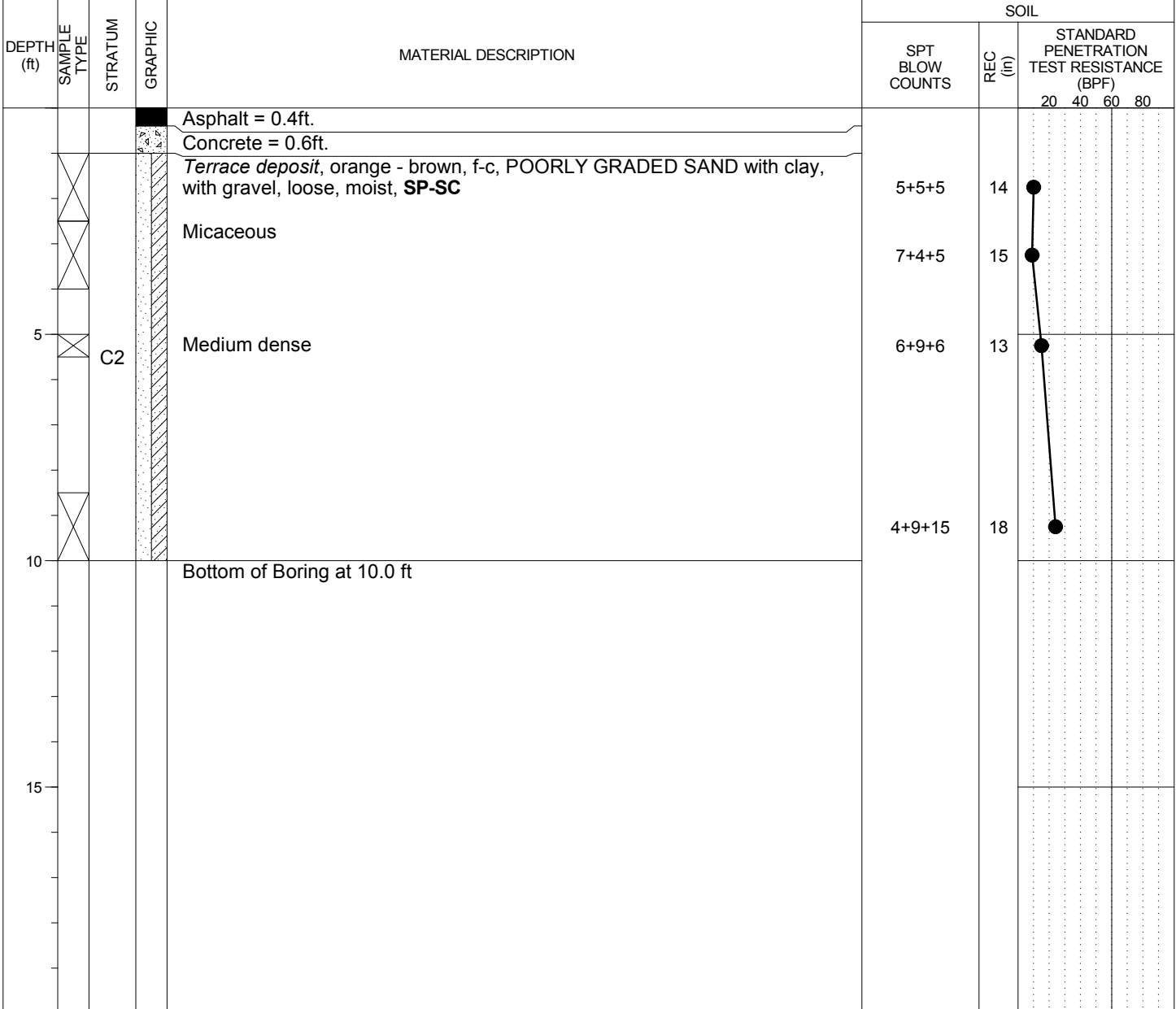

GROUND WATER LEVELS: NOT ENCOUNTERED DURING DRILLING NOT ENCOUNTERED UPON COMPLETION CAVED: <u>6.5</u> ft	SAMPLE TYPES: <input checked="" type="checkbox"/> Split Spoon
--	--

REMARKS:

THE STRATIFICATION LINES REPRESENT APPROXIMATE BOUNDARIES. THE TRANSITION MAY BE GRADUAL.

BOREHOLE/TEST PIT SEG. F LOGS.GPJ GEOCONCEPTS TEMPLATE 02-12-2015.GDT 4/22/16



PROJECT: Columbia Pike Multimodal Street Improvements		LOGGED BY: L. Pugh	BORING NUMBER: FB-16
LOCATION: Columbia Pike, Arlington, VA		DRILLING CONTRACTOR: Connelly & Associates, Inc.	
OWNER/CLIENT: Kimley-Horn & Associates, Inc.		DRILLER: Z. Macomber	DATES DRILLED: 1/28/15 - 1/28/15
PROJECT NUMBER: 14189	GROUND SURFACE ELEVATION (ft): NOT SURVEYED	DRILLING METHOD: 2.25" H.S.A	OFFSET NOTES:

DEPTH (ft)	SAMPLE TYPE	STRATUM	GRAPHIC	MATERIAL DESCRIPTION	SOIL					
					SPT BLOW COUNTS	REC (ft)	STANDARD PENETRATION TEST RESISTANCE (BPF)			MC (%)
							20	40	60	
				Asphalt = 0.2ft. Concrete = 0.3ft. <i>Terrace deposit</i> , orange - brown, f-m, POORLY GRADED SAND with clay, micaceous, loose, moist, SP-SC With gravel, medium dense						
5		C2			6+4+6	15				
					4+6+10	14				7.6
					5+7+6	18				
10				Bottom of Boring at 10.0 ft	9+11+12	16				

GROUND WATER LEVELS: NOT ENCOUNTERED DURING DRILLING NOT ENCOUNTERED UPON COMPLETION CAVED: <u>5.0</u> ft	SAMPLE TYPES: <input checked="" type="checkbox"/> Split Spoon
--	--

REMARKS:

THE STRATIFICATION LINES REPRESENT APPROXIMATE BOUNDARIES. THE TRANSITION MAY BE GRADUAL.

BOREHOLE/TEST PIT SEG. F LOGS.GPJ GEOCONCEPTS TEMPLATE 02-12-2015.GDT 4/22/16



PROJECT: Columbia Pike Multimodal Street Improvements		LOGGED BY: L. Pugh	BORING NUMBER: FB-17
LOCATION: Columbia Pike, Arlington, VA		DRILLING CONTRACTOR: Connelly & Associates, Inc.	
OWNER/CLIENT: Kimley-Horn & Associates, Inc.		DRILLER: Z. Macomber	DATES DRILLED: 1/29/15 - 1/29/15
PROJECT NUMBER: 14189	GROUND SURFACE ELEVATION (ft): NOT SURVEYED	DRILLING METHOD: 2.25" H.S.A	OFFSET NOTES:

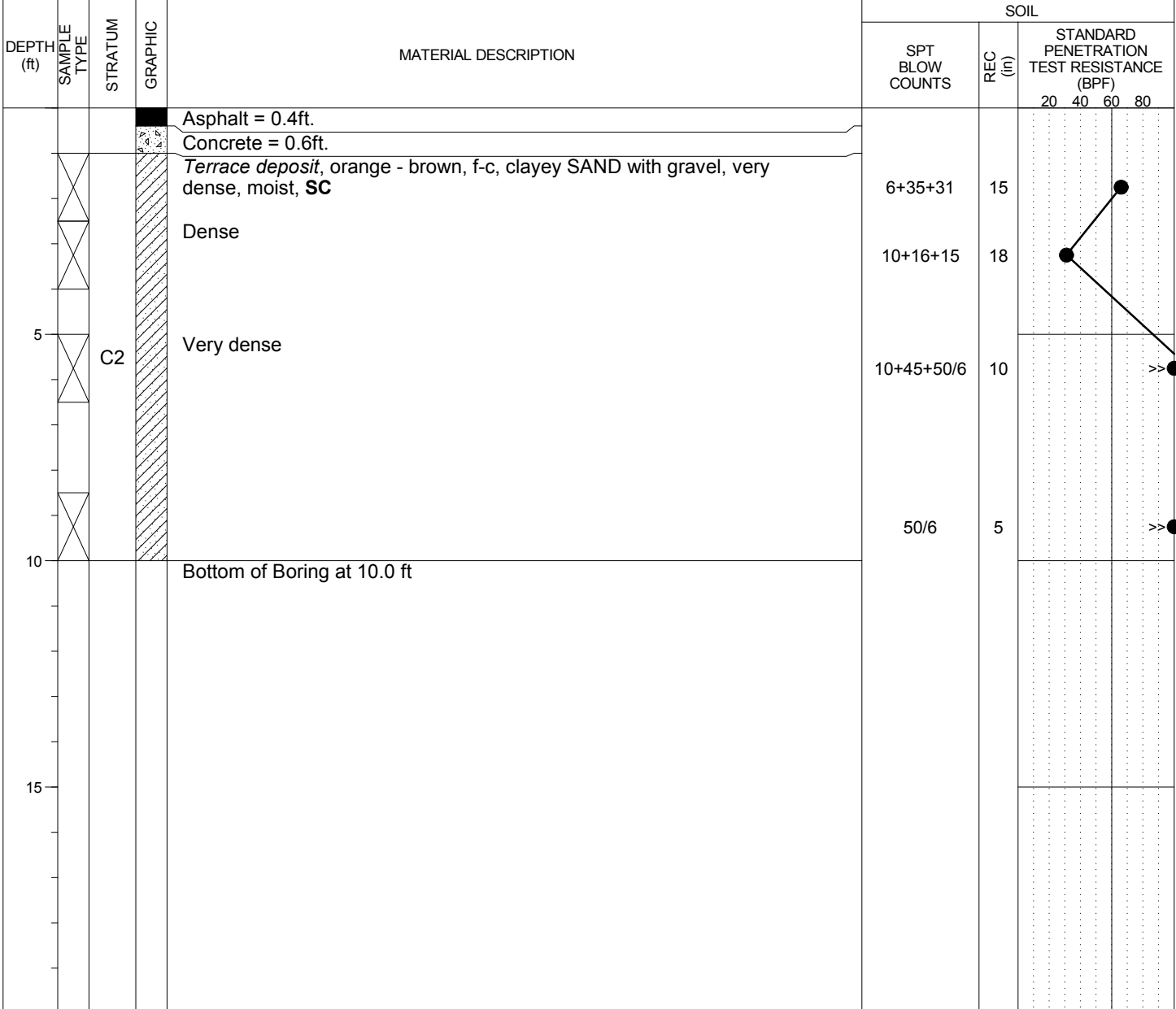

GROUND WATER LEVELS: NOT ENCOUNTERED DURING DRILLING NOT ENCOUNTERED UPON COMPLETION CAVED: <u>6.0</u> ft	SAMPLE TYPES: Split Spoon
--	------------------------------

REMARKS: Bulk sample collected from 0.0' to 5.0'

BOREHOLE/TEST PIT SEG. F LOGS.GPJ GEOCONCEPTS TEMPLATE 02-12-2015.GDT 4/22/16

THE STRATIFICATION LINES REPRESENT APPROXIMATE BOUNDARIES. THE TRANSITION MAY BE GRADUAL.



PROJECT: Columbia Pike Multimodal Street Improvements		LOGGED BY: L. Pugh		BORING NUMBER: FB-18
LOCATION: Columbia Pike, Arlington, VA		DRILLING CONTRACTOR: Connelly & Associates, Inc.		
OWNER/CLIENT: Kimley-Horn & Associates, Inc.		DRILLER: Z. Macomber	DATES DRILLED: 1/29/15 - 1/29/15	
PROJECT NUMBER: 14189	GROUND SURFACE ELEVATION (ft): NOT SURVEYED	DRILLING METHOD: 2.25" H.S.A	OFFSET NOTES:	

DEPTH (ft)	SAMPLE TYPE	STRATUM	GRAPHIC	MATERIAL DESCRIPTION	SOIL					
					SPT BLOW COUNTS	REC (ft)	STANDARD PENETRATION TEST RESISTANCE (BPF)			MC (%)
							20	40	60	
				Asphalt = 0.5ft.						
				Concrete = 0.6ft.						
				Terrace deposit, gray, LEAN CLAY, stiff, moist, CL						
				Hard	3+3+8	18				18.6
				Very stiff	10+17+18	18				
5		C1		Hard	10+14+16	18				
				Bottom of Boring at 10.0 ft	12+16+15	18				
10										
15										

GROUND WATER LEVELS: NOT ENCOUNTERED DURING DRILLING NOT ENCOUNTERED UPON COMPLETION CAVED: <u>7.0</u> ft	SAMPLE TYPES: <input checked="" type="checkbox"/> Split Spoon
--	--

REMARKS:

THE STRATIFICATION LINES REPRESENT APPROXIMATE BOUNDARIES. THE TRANSITION MAY BE GRADUAL.

BOREHOLE/TEST PIT SEG. F LOGS.GPJ GEOCONCEPTS TEMPLATE 02-12-2015.GDT 4/22/16



PROJECT: Columbia Pike Multimodal Street Improvements		LOGGED BY: L. Pugh	BORING NUMBER: HA-19 SHEET 1 OF 1
LOCATION: Columbia Pike, Arlington , VA		DRILLING CONTRACTOR: Connelly & Associates, Inc.	
OWNER/CLIENT: Kimley-Horn & Associates, Inc.		DRILLER: L. Pugh	DATES DRILLED: 2/10/15 - 2/10/15
PROJECT NUMBER: 14189	GROUND SURFACE ELEVATION (ft): NOT SURVEYED	DRILLING METHOD: Hand Augers	OFFSET NOTES:

DEPTH (ft)	SAMPLE TYPE	STRATUM	GRAPHIC	MATERIAL DESCRIPTION	SOIL	
					DCP BLOW COUNTS	Geoprobe Pen. (in)
				Asphalt = 0.9ft.		
				Crushed stone = 0.1ft.		
	D2			Potomac group, orange - brown, f-c, clayey SAND with gravel, dense, moist, SC Medium dense Dense Bottom of Boring at 2.2 ft	19+35/ 6+10+7 22+35/ 0.8	
5						
10						
15						

GROUND WATER LEVELS: NOT ENCOUNTERED DURING DRILLING NOT ENCOUNTERED UPON COMPLETION CAVED: <u>2.0</u> ft	SAMPLE TYPES:  Dynamic Cone Penetrometer
--	--

REMARKS:

THE STRATIFICATION LINES REPRESENT APPROXIMATE BOUNDARIES. THE TRANSITION MAY BE GRADUAL.

BOREHOLE/TEST PIT SEG. F LOGS.GPJ GEOCONCEPTS TEMPLATE 02-12-2015.GDT 4/22/16



PROJECT: Columbia Pike Multimodal Street Improvements		LOGGED BY: L. Pugh		BORING NUMBER: HB-1
LOCATION: Columbia Pike, Arlington , VA		DRILLING CONTRACTOR: Connelly & Associates, Inc.		
OWNER/CLIENT: Kimley-Horn & Associates, Inc.		DRILLER: Z. Macomber	DATES DRILLED: 1/13/15 - 1/13/15	
PROJECT NUMBER: 14189	GROUND SURFACE ELEVATION (ft): NOT SURVEYED	DRILLING METHOD: 2.25" H.S.A	OFFSET NOTES:	

DEPTH (ft)	SAMPLE TYPE	STRATUM	GRAPHIC	MATERIAL DESCRIPTION	SOIL		
					SPT BLOW COUNTS	REC (ft)	STANDARD PENETRATION TEST RESISTANCE (BPF) 20 40 60 80
				Asphalt = 0.5ft.			
				Crushed stone = 0.3ft.			
				Alluvial, orange - brown, f-c, clayey SAND with gravel, medium dense, moist, SC	22+20+10	7	
		B		Dense	10+19+19	0	
5				Micaceous, very dense	20+36+36	15	
				Auger Refusal at 6.5 ft			

GROUND WATER LEVELS: NOT ENCOUNTERED DURING DRILLING NOT ENCOUNTERED UPON COMPLETION CAVED: <u>3.0</u> ft	SAMPLE TYPES: <input checked="" type="checkbox"/> Split Spoon
--	--

REMARKS:

THE STRATIFICATION LINES REPRESENT APPROXIMATE BOUNDARIES. THE TRANSITION MAY BE GRADUAL.

BOREHOLE/TEST PIT SEG. H&I LOGS.GPJ GEOCONCEPTS TEMPLATE 02-12-2015.GDT 4/22/16

PROJECT: Columbia Pike Multimodal Street Improvements		LOGGED BY: L. Pugh	BORING NUMBER: HB-2
LOCATION: Columbia Pike, Arlington , VA		DRILLING CONTRACTOR: Connelly & Associates, Inc.	
OWNER/CLIENT: Kimley-Horn & Associates, Inc.		DRILLER: Z. Macomber	DATES DRILLED: 1/22/15 - 1/22/15
PROJECT NUMBER: 14189	GROUND SURFACE ELEVATION (ft): NOT SURVEYED	DRILLING METHOD: 2.25" H.S.A	OFFSET NOTES:

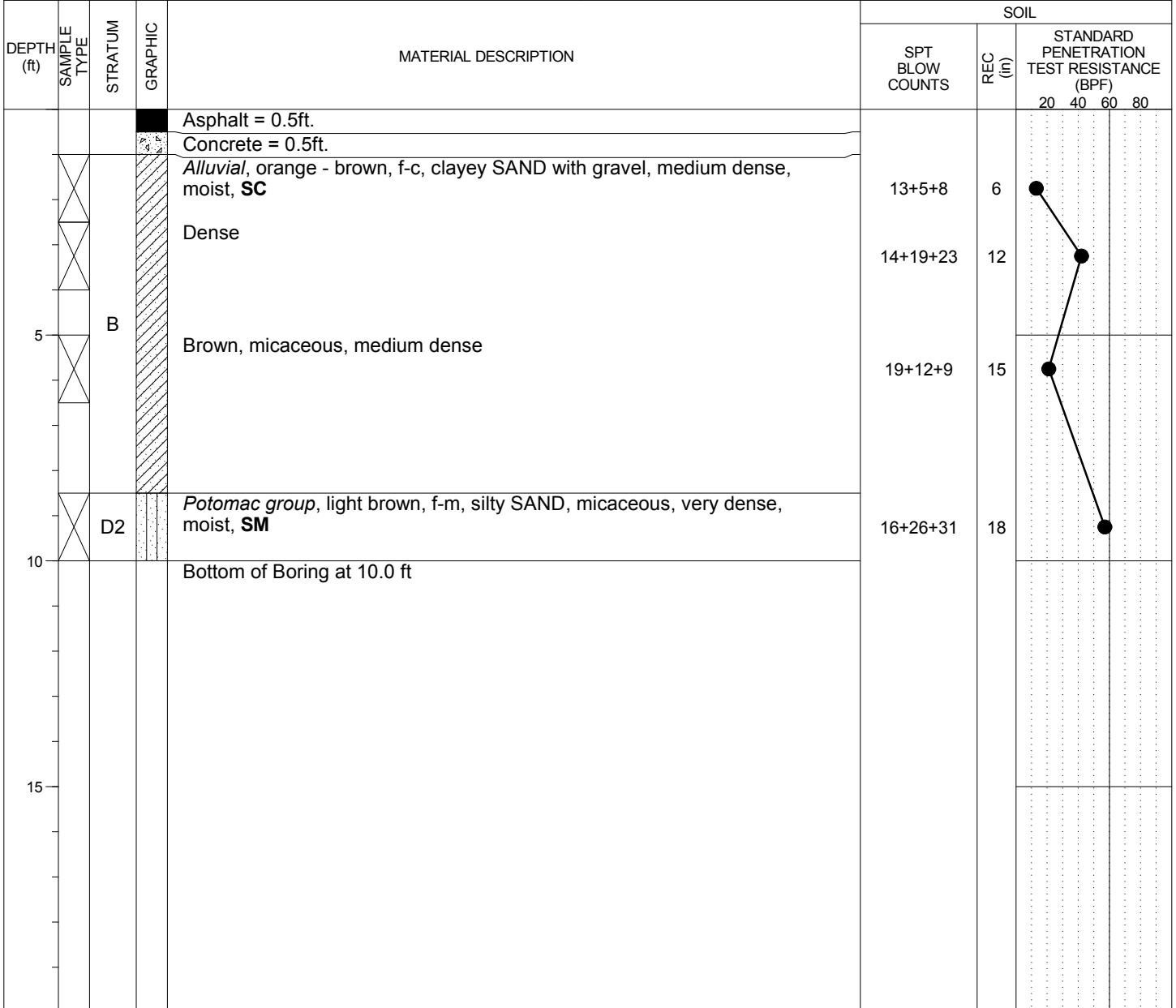

GROUND WATER LEVELS: NOT ENCOUNTERED DURING DRILLING NOT ENCOUNTERED UPON COMPLETION CAVED: <u>6.0</u> ft	SAMPLE TYPES: <input checked="" type="checkbox"/> Split Spoon
--	--

REMARKS:

THE STRATIFICATION LINES REPRESENT APPROXIMATE BOUNDARIES. THE TRANSITION MAY BE GRADUAL.

BOREHOLE/TEST PIT SEG. H&I LOGS.GPJ GEOCONCEPTS TEMPLATE 02-12-2015.GDT 4/22/16



PROJECT: Columbia Pike Multimodal Street Improvements		LOGGED BY: L. Pugh	BORING NUMBER: HB-3
LOCATION: Columbia Pike, Arlington, VA		DRILLING CONTRACTOR: Connelly & Associates, Inc.	
OWNER/CLIENT: Kimley-Horn & Associates, Inc.		DRILLER: Z. Macomber	DATES DRILLED: 1/22/15 - 1/22/15
PROJECT NUMBER: 14189	GROUND SURFACE ELEVATION (ft): NOT SURVEYED	DRILLING METHOD: 2.25" H.S.A	OFFSET NOTES:

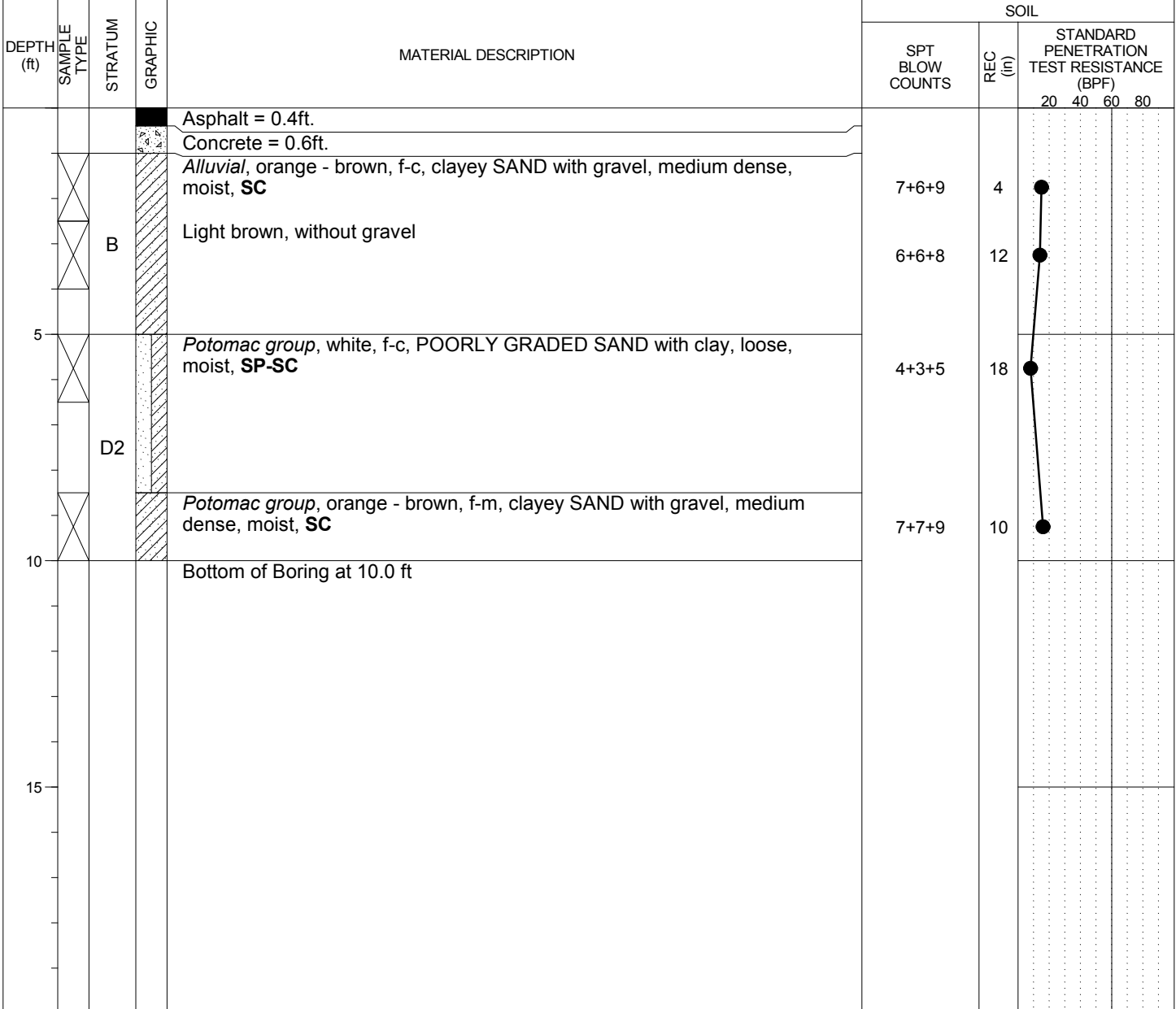

GROUND WATER LEVELS: NOT ENCOUNTERED DURING DRILLING NOT ENCOUNTERED UPON COMPLETION CAVED: <u>7.0</u> ft	SAMPLE TYPES: <input checked="" type="checkbox"/> Split Spoon
--	--

REMARKS:

THE STRATIFICATION LINES REPRESENT APPROXIMATE BOUNDARIES. THE TRANSITION MAY BE GRADUAL.

BOREHOLE/TEST PIT SEG. H&I LOGS.GPJ GEOCONCEPTS TEMPLATE 02-12-2015.GDT 4/22/16



PROJECT: Columbia Pike Multimodal Street Improvements		LOGGED BY: L. Pugh		BORING NUMBER: HB-4
LOCATION: Columbia Pike, Arlington, VA		DRILLING CONTRACTOR: Connelly & Associates, Inc.		
OWNER/CLIENT: Kimley-Horn & Associates, Inc.		DRILLER: Z. Macomber	DATES DRILLED: 1/19/15 - 1/19/15	
PROJECT NUMBER: 14189	GROUND SURFACE ELEVATION (ft): NOT SURVEYED	DRILLING METHOD: 2.25" H.S.A	OFFSET NOTES:	

DEPTH (ft)	SAMPLE TYPE	STRATUM	GRAPHIC	MATERIAL DESCRIPTION	SOIL					
					SPT BLOW COUNTS	REC (ft)	STANDARD PENETRATION TEST RESISTANCE (BPF)			MC (%)
							20	40	60	
				Asphalt = 0.4ft. Concrete = 0.6ft.						
	D2			Potomac group, orange - brown, f-c, clayey SAND with gravel, loose, moist, SC	4+3+3	9				12.2
	E1			Residual, gray, f-m, silty SAND, micaceous, dense, moist, SM	8+11+25	4				9.7
5				Weathered rock, gray, silty SAND, micaceous, very dense, moist, SM	50/6	4				>> 22.3
	E2									
10				Bottom of Boring at 9.8 ft	25+34+50/4	16				>> 1.2

GROUND WATER LEVELS: NOT ENCOUNTERED DURING DRILLING NOT ENCOUNTERED UPON COMPLETION CAVED: <u>6.5</u> ft	SAMPLE TYPES: <input checked="" type="checkbox"/> Split Spoon
--	--

REMARKS:

THE STRATIFICATION LINES REPRESENT APPROXIMATE BOUNDARIES. THE TRANSITION MAY BE GRADUAL.

BOREHOLE/TEST PIT SEG. H&I LOGS.GPJ GEOCONCEPTS TEMPLATE 02-12-2015.GDT 4/22/16

PROJECT: Columbia Pike Multimodal Street Improvements		LOGGED BY: L. Pugh	BORING NUMBER: HB-5
LOCATION: Columbia Pike, Arlington, VA		DRILLING CONTRACTOR: Connelly & Associates, Inc.	
OWNER/CLIENT: Kimley-Horn & Associates, Inc.		DRILLER: Z. Macomber	DATES DRILLED: 1/28/15 - 1/28/15
PROJECT NUMBER: 14189	GROUND SURFACE ELEVATION (ft): NOT SURVEYED	DRILLING METHOD: 2.25" H.S.A	OFFSET NOTES:

DEPTH (ft)	SAMPLE TYPE	STRATUM	GRAPHIC	MATERIAL DESCRIPTION	SOIL						
					SPT BLOW COUNTS	REC (ft)	STANDARD PENETRATION TEST RESISTANCE (BPF)			MC (%)	
							20	40	60		80
				Asphalt = 0.4ft.							
				Concrete = 0.6ft.							
				Potomac group, white and orange brown, f-c, clayey SAND, medium dense, moist, SC	5+7+12	12					
				Contains gravel, dense	15+13+18	16					17.3
5		D2		Medium dense	6+11+11	18					
				Potomac group, yellow and white, f-c, POORLY GRADED SAND with clay, with gravel, very dense, moist, SP-SC	16+20+45	18					
10				Bottom of Boring at 10.0 ft							

GROUND WATER LEVELS: NOT ENCOUNTERED DURING DRILLING NOT ENCOUNTERED UPON COMPLETION CAVED: <u>5.5</u> ft	SAMPLE TYPES: <input checked="" type="checkbox"/> Split Spoon
--	--

REMARKS: Bulk sample collected from 0.0' to 5.0'

BOREHOLE/TEST PIT SEG. H&I LOGS.GPJ GEOCONCEPTS TEMPLATE 02-12-2015.GDT 4/22/16

PROJECT: Columbia Pike Multimodal Street Improvements		LOGGED BY: L. Pugh	BORING NUMBER: HB-6
LOCATION: Columbia Pike, Arlington , VA		DRILLING CONTRACTOR: Connelly & Associates, Inc.	
OWNER/CLIENT: Kimley-Horn & Associates, Inc.		DRILLER: Z. Macomber	DATES DRILLED: 1/28/15 - 1/28/15
PROJECT NUMBER: 14189	GROUND SURFACE ELEVATION (ft): NOT SURVEYED	DRILLING METHOD: 2.25" H.S.A	OFFSET NOTES:

DEPTH (ft)	SAMPLE TYPE	STRATUM	GRAPHIC	MATERIAL DESCRIPTION	SOIL		
					SPT BLOW COUNTS	REC (ft)	STANDARD PENETRATION TEST RESISTANCE (BPF) 20 40 60 80
				Asphalt = 0.5ft.			
				Concrete = 0.5ft.			
				Potomac group, white, f-c, clayey SAND, contains gravel, medium dense, moist, SC	6+9+12	14	●
				Without gravel	7+14+14	6	●
5		D2			9+11+11	18	●
				Contains gravel	6+11+13	18	●
10				Bottom of Boring at 10.0 ft			
15							

GROUND WATER LEVELS: NOT ENCOUNTERED DURING DRILLING NOT ENCOUNTERED UPON COMPLETION CAVED: <u>6.0</u> ft	SAMPLE TYPES: <input checked="" type="checkbox"/> Split Spoon
--	--

REMARKS:

THE STRATIFICATION LINES REPRESENT APPROXIMATE BOUNDARIES. THE TRANSITION MAY BE GRADUAL.



PROJECT: Columbia Pike Multimodal Street Improvements		LOGGED BY: L. Pugh		BORING NUMBER: HB-7
LOCATION: Columbia Pike, Arlington, VA		DRILLING CONTRACTOR: Connelly & Associates, Inc.		
OWNER/CLIENT: Kimley-Horn & Associates, Inc.		DRILLER: Z. Macomber	DATES DRILLED: 1/28/15 - 1/28/15	
PROJECT NUMBER: 14189	GROUND SURFACE ELEVATION (ft): NOT SURVEYED	DRILLING METHOD: 2.25" H.S.A	OFFSET NOTES:	

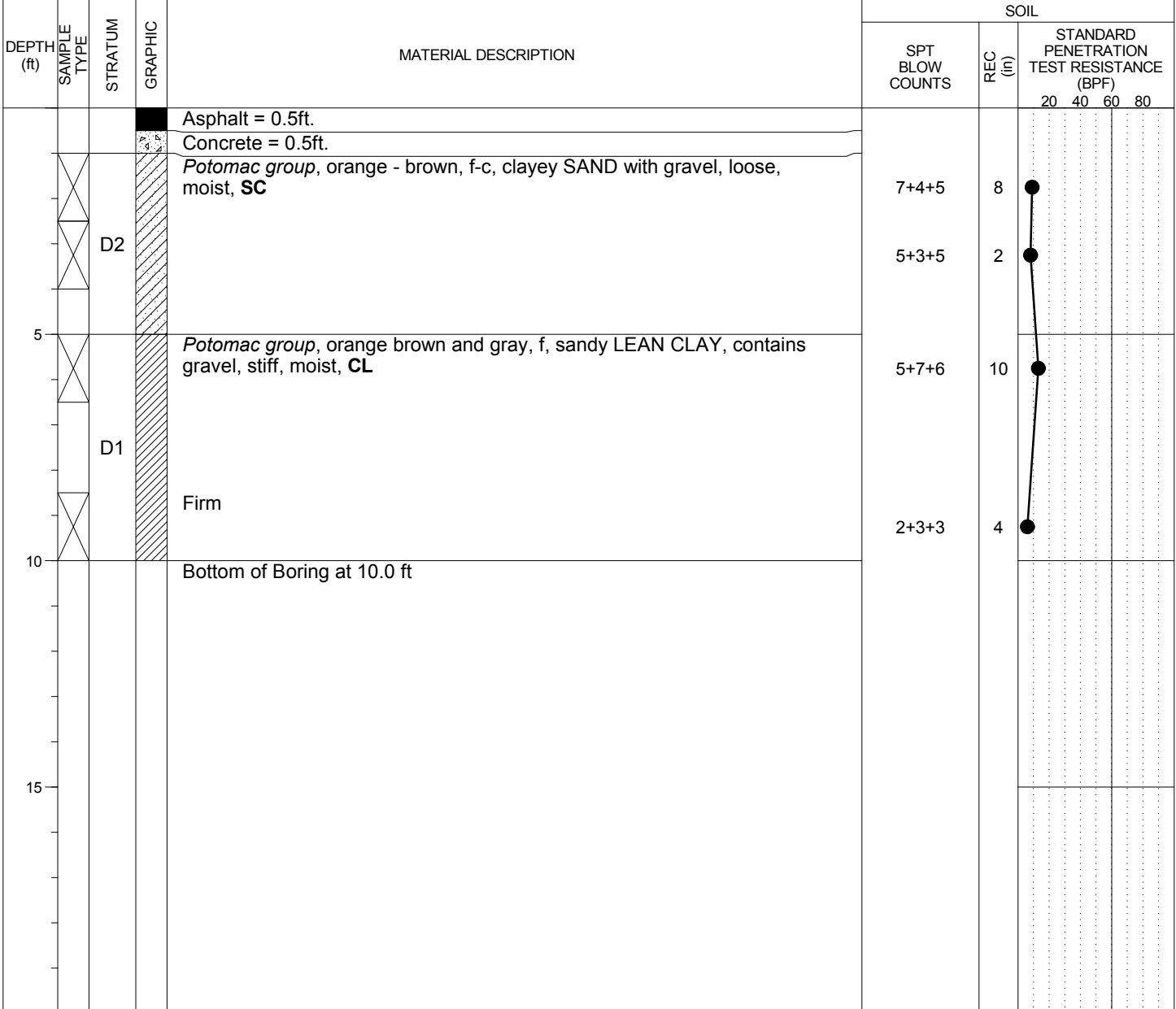

GROUND WATER LEVELS: NOT ENCOUNTERED DURING DRILLING NOT ENCOUNTERED UPON COMPLETION CAVED: <u>6.0</u> ft	SAMPLE TYPES: <input checked="" type="checkbox"/> Split Spoon
--	--

REMARKS:

THE STRATIFICATION LINES REPRESENT APPROXIMATE BOUNDARIES. THE TRANSITION MAY BE GRADUAL.

BOREHOLE/TEST PIT SEG. H&I LOGS.GPJ GEOCONCEPTS TEMPLATE 02-12-2015.GDT 4/22/16



PROJECT: Columbia Pike Multimodal Street Improvements		LOGGED BY: L. Pugh	BORING NUMBER: IRW-1
LOCATION: Columbia Pike, Arlington , VA		DRILLING CONTRACTOR: Connelly & Associates, Inc.	
OWNER/CLIENT: Kimley-Horn & Associates, Inc.		DRILLER: Z. Macomber	DATES DRILLED: 1/13/15 - 1/13/15
PROJECT NUMBER: 14189	GROUND SURFACE ELEVATION (ft): NOT SURVEYED	DRILLING METHOD: 2.25" H.S.A	OFFSET NOTES:

DEPTH (ft)	SAMPLE TYPE	STRATUM	GRAPHIC	MATERIAL DESCRIPTION	SOIL			
					SPT BLOW COUNTS	REC (ft)	STANDARD PENETRATION TEST RESISTANCE (BPF) 20 40 60 80	MC (%)
0 - 0.2		A		Topsoil = 0.2ft.	1+1+1	12		20.9
0.2 - 5		D2		Potomac group, orange - brown, f, POORLY GRADED GRAVEL with sand, dense, moist, GP	10+17+15	1		2.0
5 - 10		E1		Residual, orange - brown, f-m, silty SAND, micaceous, very stiff, moist, SM	12+11+10	10		18.7
10 - 15				Dark gray, very hard	20+29+42	18		13.6
15 - 15.5				Very stiff	19+16+14	18		20.6
15.5 - 15.5				Bottom of Boring at 15.0 ft				

GROUND WATER LEVELS: NOT ENCOUNTERED DURING DRILLING NOT ENCOUNTERED UPON COMPLETION CAVED: <u>10.5</u> ft	SAMPLE TYPES: Split Spoon
---	------------------------------

REMARKS:

THE STRATIFICATION LINES REPRESENT APPROXIMATE BOUNDARIES. THE TRANSITION MAY BE GRADUAL.

BOREHOLE/TEST PIT SEG. H&I LOGS.GPJ GEOCONCEPTS TEMPLATE 02-12-2015.GDT 4/22/16



PROJECT: Columbia Pike Multimodal Street Improvements		LOGGED BY: L. Pugh	BORING NUMBER: HA-2
LOCATION: Columbia Pike, Arlington , VA		DRILLING CONTRACTOR: GeoConcepts Engineering, Inc.	SHEET 1 OF 1
OWNER/CLIENT: Kimley-Horn & Associates, Inc.		DRILLER: L. Pugh	DATES DRILLED: 1/15/15 - 1/15/15
PROJECT NUMBER: 14189	GROUND SURFACE ELEVATION (ft): NOT SURVEYED	DRILLING METHOD: Hand Auger	OFFSET NOTES:

DEPTH (ft)	SAMPLE TYPE	STRATUM	GRAPHIC	MATERIAL DESCRIPTION	SOIL	
					DCP BLOW COUNTS	Geoprobe Pen. (in)
0		A		Topsoil = 0.3ft.	3+12+15	5
0.3				Fill, brown, f, POORLY GRADED GRAVEL, medium dense, moist, GP		
0.5				Hand Auger Refusal at 0.5 ft		
5						
10						
15						

GROUND WATER LEVELS: NOT ENCOUNTERED DURING DRILLING NOT ENCOUNTERED UPON COMPLETION CAVED: <u>0.5</u> ft	SAMPLE TYPES: Dynamic Cone Penetrometer
--	--

REMARKS:

THE STRATIFICATION LINES REPRESENT APPROXIMATE BOUNDARIES. THE TRANSITION MAY BE GRADUAL.

BOREHOLE/TEST PIT SEG. H&I LOGS.GPJ GEOCONCEPTS TEMPLATE 02-12-2015.GDT 4/22/16



PROJECT: Columbia Pike Multimodal Street Improvements		LOGGED BY: L. Pugh	BORING NUMBER: HA-3
LOCATION: Columbia Pike, Arlington , VA		DRILLING CONTRACTOR: GeoConcepts Engineering, Inc.	
OWNER/CLIENT: Kimley-Horn & Associates, Inc.		DRILLER: L. Pugh	DATES DRILLED: 1/15/15 - 1/15/15
PROJECT NUMBER: 14189	GROUND SURFACE ELEVATION (ft): NOT SURVEYED	DRILLING METHOD: Hand Auger	OFFSET NOTES:

DEPTH (ft)	SAMPLE TYPE	STRATUM	GRAPHIC	MATERIAL DESCRIPTION	SOIL	
					DCP BLOW COUNTS	Geoprobe Pen. (in)
				Concrete = 0.3ft.		
		A		Fill, brown, f-c, clayey SAND, loose, moist, SC	2+3+3	5
				Fill, brown, f-c, sandy LEAN CLAY with gravel, very stiff, moist, CL	2+4+15	5
					9+9+9	5
		D2		Potomac group, orange - brown, f-c, clayey SAND with gravel, very dense, moist, SC	19+35/	2
5				Hand Auger Refusal at 4.5 ft		

GROUND WATER LEVELS: NOT ENCOUNTERED DURING DRILLING NOT ENCOUNTERED UPON COMPLETION CAVED: <u>4.5</u> ft	SAMPLE TYPES: Dynamic Cone Penetrometer
--	--

REMARKS:

THE STRATIFICATION LINES REPRESENT APPROXIMATE BOUNDARIES. THE TRANSITION MAY BE GRADUAL.

BOREHOLE/TEST PIT SEG. H&I LOGS.GPJ GEOCONCEPTS TEMPLATE 02-12-2015.GDT 4/22/16



PROJECT: Columbia Pike Multimodal Street Improvements		LOGGED BY: L. Pugh	BORING NUMBER: HA-4 SHEET 1 OF 1
LOCATION: Columbia Pike, Arlington , VA		DRILLING CONTRACTOR: GeoConcepts Engineering, Inc.	
OWNER/CLIENT: Kimley-Horn & Associates, Inc.		DRILLER: L. Pugh	DATES DRILLED: 1/15/15 - 1/15/15
PROJECT NUMBER: 14189	GROUND SURFACE ELEVATION (ft): NOT SURVEYED	DRILLING METHOD: Hand Auger	OFFSET NOTES:

DEPTH (ft)	SAMPLE TYPE	STRATUM	GRAPHIC	MATERIAL DESCRIPTION	SOIL	
					DCP BLOW COUNTS	Geoprobe Pen. (in)
				Concrete = 0.3ft.		
		A		Fill, brown, f-c, clayey SAND with gravel, medium dense, moist, SC	6+12+18	5
				Hand Auger Refusal at 2.5 ft	6+14+14	5
5						
10						
15						

GROUND WATER LEVELS: NOT ENCOUNTERED DURING DRILLING NOT ENCOUNTERED UPON COMPLETION CAVED: <u>2.5</u> ft	SAMPLE TYPES: Dynamic Cone Penetrometer
--	--

REMARKS:

THE STRATIFICATION LINES REPRESENT APPROXIMATE BOUNDARIES. THE TRANSITION MAY BE GRADUAL.

BOREHOLE/TEST PIT SEG. H&I LOGS.GPJ GEOCONCEPTS TEMPLATE 02-12-2015.GDT 4/22/16

PROJECT: Columbia Pike Multimodal Street Improvements		LOGGED BY: L. Pugh	BORING NUMBER: IRW-4A
LOCATION: Columbia Pike, Arlington, VA		DRILLING CONTRACTOR: Connelly & Associates, Inc.	
OWNER/CLIENT: Kimley-Horn & Associates, Inc.		DRILLER: Z. Macomber	DATES DRILLED: 1/20/15 - 1/20/15
PROJECT NUMBER: 14189	GROUND SURFACE ELEVATION (ft): NOT SURVEYED	DRILLING METHOD: 2.25" H.S.A	OFFSET NOTES:

DEPTH (ft)	SAMPLE TYPE	STRATUM	GRAPHIC	MATERIAL DESCRIPTION	SOIL		
					SPT BLOW COUNTS	REC (ft)	STANDARD PENETRATION TEST RESISTANCE (BPF) 20 40 60 80
				Asphalt = 0.4ft.			
				Concrete = 0.6ft.			
				<i>Potomac group</i> , orange - brown, f-c, clayey SAND with gravel, loose, moist, SC	6+5+4	13	
				Medium dense, without gravel	3+6+13	18	
5				<i>Potomac group</i> , light brown, f-c, POORLY GRADED SAND with clay and gravel, very dense, moist, SP-SC	13+35+50/6	18	>>
		D2		<i>Potomac group</i> , light brown, f-c, clayey SAND with gravel, medium dense, moist, SC	18+12+12	18	
10							
				Wet	7+10+14	18	
15				Bottom of Boring at 15.0 ft			

GROUND WATER LEVELS: ▽ ENCOUNTERED: <u>13.0</u> ft ▽ UPON COMPLETION: <u>13.0</u> ft 1/20/2015: NOT ENCOUNTERED CAVED: <u>8.0</u> ft	SAMPLE TYPES: <input checked="" type="checkbox"/> Split Spoon
--	--

REMARKS:

THE STRATIFICATION LINES REPRESENT APPROXIMATE BOUNDARIES. THE TRANSITION MAY BE GRADUAL.



PROJECT: Columbia Pike Multimodal Street Improvements		LOGGED BY: L. Pugh		BORING NUMBER: IB-1
LOCATION: Columbia Pike, Arlington , VA		DRILLING CONTRACTOR: Connelly & Associates, Inc.		
OWNER/CLIENT: Kimley-Horn & Associates, Inc.		DRILLER: Z. Macomber	DATES DRILLED: 1/21/15 - 1/21/15	
PROJECT NUMBER: 14189	GROUND SURFACE ELEVATION (ft): NOT SURVEYED	DRILLING METHOD: 2.25" H.S.A	OFFSET NOTES:	

DEPTH (ft)	SAMPLE TYPE	STRATUM	GRAPHIC	MATERIAL DESCRIPTION	SOIL		
					SPT BLOW COUNTS	REC (ft)	STANDARD PENETRATION TEST RESISTANCE (BPF) 20 40 60 80
				Asphalt = 0.5ft.			
				Concrete = 0.5ft.			
				Fill, orange - brown, f-c, clayey SAND with gravel, loose, moist, SC	5+5+5	15	
		A		Very dense	4+6+50/6	14	>>>
				Crushed asphalt			
5				Potomac group, light brown, f-c, clayey SAND with gravel, medium dense, moist, SC	11+10+13	18	
		D2					
10				Bottom of Boring at 10.0 ft	8+10+14	18	

GROUND WATER LEVELS: NOT ENCOUNTERED DURING DRILLING NOT ENCOUNTERED UPON COMPLETION CAVED: <u>5.0</u> ft	SAMPLE TYPES: <input checked="" type="checkbox"/> Split Spoon
--	--

REMARKS:

THE STRATIFICATION LINES REPRESENT APPROXIMATE BOUNDARIES. THE TRANSITION MAY BE GRADUAL.

BOREHOLE/TEST PIT SEG. H&I LOGS.GPJ GEOCONCEPTS TEMPLATE 02-12-2015.GDT 4/22/16



PROJECT: Columbia Pike Multimodal Street Improvements		LOGGED BY: L. Pugh		BORING NUMBER: IB-2
LOCATION: Columbia Pike, Arlington, VA		DRILLING CONTRACTOR: Connelly & Associates, Inc.		
OWNER/CLIENT: Kimley-Horn & Associates, Inc.		DRILLER: Z. Macomber	DATES DRILLED: 1/20/15 - 1/20/15	
PROJECT NUMBER: 14189	GROUND SURFACE ELEVATION (ft): NOT SURVEYED	DRILLING METHOD: 2.25" H.S.A	OFFSET NOTES:	

DEPTH (ft)	SAMPLE TYPE	STRATUM	GRAPHIC	MATERIAL DESCRIPTION	SOIL						
					SPT BLOW COUNTS	REC (ft)	STANDARD PENETRATION TEST RESISTANCE (BPF)		MC (%)		
							20	40		60	80
				Asphalt = 0.4ft.							
				Concrete = 0.6ft.							
				Potomac group, brown, f-c, sandy FAT CLAY, with gravel, stiff, moist, CH	5+7+8	16					
				Orange - brown, very stiff							
5		D1		Without gravel	8+12+14	18					24.7
				Potomac group, light brown, f-c, POORLY GRADED SAND with clay, medium dense, moist, SP-SC	5+7+8	18					
10		D2			9+11+14	18					
				Potomac group, light brown and orange brown, f, sandy LEAN CLAY, very stiff, moist, CL	9+9+18	18					
15				Bottom of Boring at 15.0 ft							

GROUND WATER LEVELS: NOT ENCOUNTERED DURING DRILLING NOT ENCOUNTERED UPON COMPLETION CAVED: <u>8.5</u> ft	SAMPLE TYPES: <input checked="" type="checkbox"/> Split Spoon
--	--

REMARKS: Bulk sample collected from 0.0' to 5.0'

BOREHOLE/TEST PIT SEG. H&I LOGS.GPJ GEOCONCEPTS TEMPLATE 02-12-2015.GDT 4/22/16



PROJECT: Columbia Pike Multimodal Street Improvements		LOGGED BY: L. Pugh	BORING NUMBER: IB-3
LOCATION: Columbia Pike, Arlington, VA		DRILLING CONTRACTOR: Connelly & Associates, Inc.	
OWNER/CLIENT: Kimley-Horn & Associates, Inc.		DRILLER: Z. Macomber	DATES DRILLED: 1/20/15 - 1/20/15
PROJECT NUMBER: 14189	GROUND SURFACE ELEVATION (ft): NOT SURVEYED	DRILLING METHOD: 2.25" H.S.A	OFFSET NOTES:

DEPTH (ft)	SAMPLE TYPE	STRATUM	GRAPHIC	MATERIAL DESCRIPTION	SOIL		
					SPT BLOW COUNTS	REC (ft)	STANDARD PENETRATION TEST RESISTANCE (BPF) 20 40 60 80
				Asphalt = 1ft.			
		A		Fill, orange - brown, f-c, clayey SAND with gravel, medium dense, moist, SC Crushed asphalt	12+7+7 12+50/6	3 10	
5		D2		Potomac group, dark gray, f-c, clayey SAND with gravel, medium dense, moist, SC	14+12+10	10	
10				Bottom of Boring at 10.0 ft	16+37+28	18	

GROUND WATER LEVELS: NOT ENCOUNTERED DURING DRILLING NOT ENCOUNTERED UPON COMPLETION CAVED: <u>5.0</u> ft	SAMPLE TYPES: Split Spoon
--	----------------------------------

REMARKS:

THE STRATIFICATION LINES REPRESENT APPROXIMATE BOUNDARIES. THE TRANSITION MAY BE GRADUAL.

BOREHOLE/TEST PIT SEG. H&I LOGS.GPJ GEOCONCEPTS TEMPLATE 02-12-2015.GDT 4/22/16

PROJECT: Columbia Pike Multimodal Street Improvements		LOGGED BY: L. Pugh	BORING NUMBER: IB-4
LOCATION: Columbia Pike, Arlington , VA		DRILLING CONTRACTOR: Connelly & Associates, Inc.	
OWNER/CLIENT: Kimley-Horn & Associates, Inc.		DRILLER: Z. Macomber	DATES DRILLED: 1/20/15 - 1/20/15
PROJECT NUMBER: 14189	GROUND SURFACE ELEVATION (ft): NOT SURVEYED	DRILLING METHOD: 2.25" H.S.A	OFFSET NOTES:

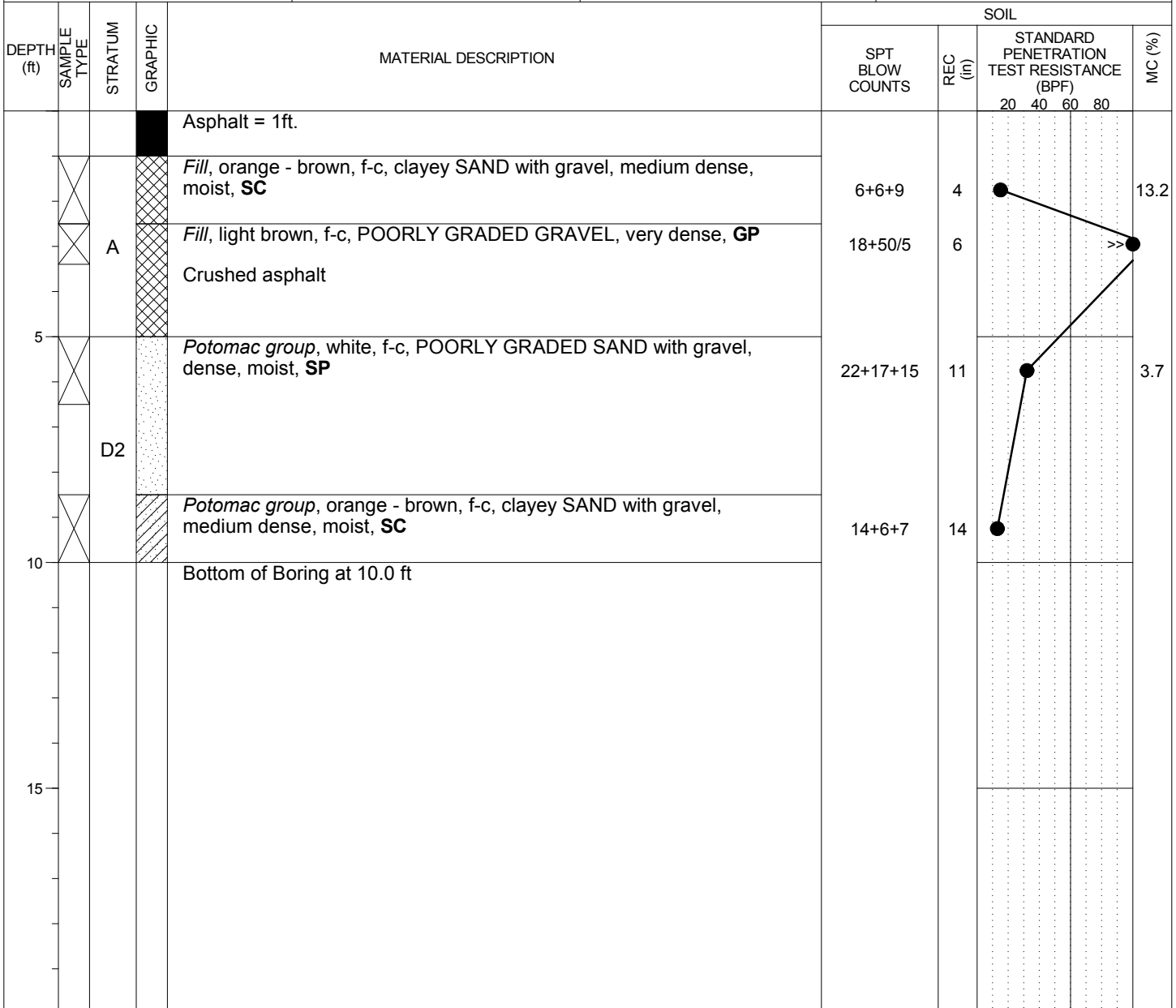

GROUND WATER LEVELS: NOT ENCOUNTERED DURING DRILLING NOT ENCOUNTERED UPON COMPLETION CAVED: <u>5.0</u> ft	SAMPLE TYPES: <input checked="" type="checkbox"/> Split Spoon
--	--

REMARKS:

THE STRATIFICATION LINES REPRESENT APPROXIMATE BOUNDARIES. THE TRANSITION MAY BE GRADUAL.

PROJECT: Columbia Pike Multimodal Street Improvements		LOGGED BY: L. Pugh	BORING NUMBER: IB-5
LOCATION: Columbia Pike, Arlington , VA		DRILLING CONTRACTOR: Connelly & Associates, Inc.	
OWNER/CLIENT: Kimley-Horn & Associates, Inc.		DRILLER: Z. Macomber	DATES DRILLED: 1/15/15 - 1/15/15
PROJECT NUMBER: 14189	GROUND SURFACE ELEVATION (ft): NOT SURVEYED	DRILLING METHOD: 2.25" H.S.A	OFFSET NOTES:

DEPTH (ft)	SAMPLE TYPE	STRATUM	GRAPHIC	MATERIAL DESCRIPTION	SOIL		
					SPT BLOW COUNTS	REC (ft)	STANDARD PENETRATION TEST RESISTANCE (BPF) 20 40 60 80
				Asphalt = 0.7ft.			
				Crushed stone = 0.2ft.			
		D2		<i>Potomac group</i> , orange - brown, f-c, clayey SAND with gravel, dense, moist, SC Loose	23+20+25	18	●
5		E1		<i>Residual</i> , gray, f-m, sandy SILT, micaceous, stiff, moist, ML	5+6+4	0	●
				<i>Residual</i> , orange - brown, f-c, silty SAND, micaceous, dense, moist, SM	7+6+6	15	●
10				Bottom of Boring at 10.0 ft	9+15+17	18	●

GROUND WATER LEVELS: NOT ENCOUNTERED DURING DRILLING NOT ENCOUNTERED UPON COMPLETION CAVED: <u>5.5</u> ft	SAMPLE TYPES: <input checked="" type="checkbox"/> Split Spoon
--	--

REMARKS:

THE STRATIFICATION LINES REPRESENT APPROXIMATE BOUNDARIES. THE TRANSITION MAY BE GRADUAL.

BOREHOLE/TEST PIT SEG. H&I LOGS.GPJ GEOCONCEPTS TEMPLATE 02-12-2015.GDT 4/22/16



PROJECT: Columbia Pike Multimodal Street Improvements		LOGGED BY: L. Pugh		BORING NUMBER: IB-6
LOCATION: Columbia Pike, Arlington , VA		DRILLING CONTRACTOR: Connelly & Associates, Inc.		
OWNER/CLIENT: Kimley-Horn & Associates, Inc.		DRILLER: Z. Macomber	DATES DRILLED: 1/15/15 - 1/15/15	
PROJECT NUMBER: 14189	GROUND SURFACE ELEVATION (ft): NOT SURVEYED	DRILLING METHOD: 2.25" H.S.A	OFFSET NOTES:	

DEPTH (ft)	SAMPLE TYPE	STRATUM	GRAPHIC	MATERIAL DESCRIPTION	SOIL		
					SPT BLOW COUNTS	REC (ft)	STANDARD PENETRATION TEST RESISTANCE (BPF) 20 40 60 80
				Asphalt = 0.6ft.			
				Crushed stone = 0.3ft.			
	A			Fill, brown, f-c, POORLY GRADED SAND with gravel, medium dense, moist, SP	22+7+22	2	
	D2			Potomac group, orange - brown, f-c, clayey SAND with gravel, medium dense, moist, SC	35+12+16	15	
5				Residual, orange - brown, f-m, sandy SILT, micaceous, stiff, moist, ML	5+6+7	18	
				Very stiff			
10	E1				6+10+12	18	
				Gray			
15				Bottom of Boring at 15.0 ft	9+14+20	18	

GROUND WATER LEVELS: NOT ENCOUNTERED DURING DRILLING NOT ENCOUNTERED UPON COMPLETION CAVED: <u>11.0</u> ft	SAMPLE TYPES: <input checked="" type="checkbox"/> Split Spoon
---	--

REMARKS:

THE STRATIFICATION LINES REPRESENT APPROXIMATE BOUNDARIES. THE TRANSITION MAY BE GRADUAL.

BOREHOLE/TEST PIT SEG. H&I LOGS.GPJ GEOCONCEPTS TEMPLATE 02-12-2015.GDT 4/22/16



PROJECT: Columbia Pike Multimodal Street Improvements		LOGGED BY: L. Pugh		BORING NUMBER: IB-7
LOCATION: Columbia Pike, Arlington , VA		DRILLING CONTRACTOR: Connelly & Associates, Inc.		
OWNER/CLIENT: Kimley-Horn & Associates, Inc.		DRILLER: Z. Macomber	DATES DRILLED: 1/19/15 - 1/19/15	
PROJECT NUMBER: 14189	GROUND SURFACE ELEVATION (ft): NOT SURVEYED	DRILLING METHOD: 2.25" H.S.A	OFFSET NOTES:	

DEPTH (ft)	SAMPLE TYPE	STRATUM	GRAPHIC	MATERIAL DESCRIPTION	SOIL		
					SPT BLOW COUNTS	REC (ft)	STANDARD PENETRATION TEST RESISTANCE (BPF) 20 40 60 80
				Asphalt = 0.9ft.			
		D2		Crushed stone = 0.1ft. <i>Potomac group</i> , orange - brown, f-c, clayey SAND with gravel, medium dense, moist, SC	7+17+12	10	
				<i>Residual</i> , gray, f-m, silty SAND, micaceous, medium dense, moist, SM	5+6+9	14	
5		E1			2+10+15	18	
		E2		<i>Weathered rock</i> , gray, f-m, silty SAND, micaceous, very dense, moist, SM	15+25+45	18	
10				Bottom of Boring at 10.0 ft			

GROUND WATER LEVELS: NOT ENCOUNTERED DURING DRILLING NOT ENCOUNTERED UPON COMPLETION CAVED: <u>7.0</u> ft	SAMPLE TYPES: <input checked="" type="checkbox"/> Split Spoon
--	--

REMARKS:

THE STRATIFICATION LINES REPRESENT APPROXIMATE BOUNDARIES. THE TRANSITION MAY BE GRADUAL.

BOREHOLE/TEST PIT SEG. H&I LOGS.GPJ GEOCONCEPTS TEMPLATE 02-12-2015.GDT 4/22/16

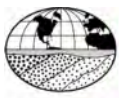

PROJECT: Columbia Pike Multimodal Street Improvements		LOGGED BY: L. Pugh		BORING NUMBER: IB-8
LOCATION: Columbia Pike, Arlington, VA		DRILLING CONTRACTOR: Connelly & Associates, Inc.		
OWNER/CLIENT: Kimley-Horn & Associates, Inc.		DRILLER: Z. Macomber	DATES DRILLED: 1/15/15 - 1/15/15	
PROJECT NUMBER: 14189	GROUND SURFACE ELEVATION (ft): NOT SURVEYED	DRILLING METHOD: 2.25" H.S.A	OFFSET NOTES:	

DEPTH (ft)	SAMPLE TYPE	STRATUM	GRAPHIC	MATERIAL DESCRIPTION	SOIL		
					SPT BLOW COUNTS	REC (ft)	STANDARD PENETRATION TEST RESISTANCE (BPF) 20 40 60 80
				Asphalt = 0.8ft.			
				Crushed stone = 0.2ft.			
				Potomac group, orange - brown, f-c, clayey SAND with gravel, medium dense, moist, SC Dark gray, micaceous	10+6+7	12	
					4+4+7	10	
5		D2		Potomac group, orange - brown, c, POORLY GRADED GRAVEL, loose, moist, GP	4+4+6	1	
				Potomac group, brown, f-c, clayey SAND, micaceous, firm, moist, SC	3+3+4	0	
10				Bottom of Boring at 10.0 ft			

GROUND WATER LEVELS: NOT ENCOUNTERED DURING DRILLING NOT ENCOUNTERED UPON COMPLETION CAVED: <u>6.5</u> ft	SAMPLE TYPES: <input checked="" type="checkbox"/> Split Spoon
--	--

REMARKS:

THE STRATIFICATION LINES REPRESENT APPROXIMATE BOUNDARIES. THE TRANSITION MAY BE GRADUAL.

BOREHOLE/TEST PIT SEG. H&I LOGS.GPJ GEOCONCEPTS TEMPLATE 02-12-2015.GDT 4/22/16



PROJECT: Columbia Pike Multimodal Street Improvements		LOGGED BY: L. Pugh		BORING NUMBER: IB-9
LOCATION: Columbia Pike, Arlington, VA		DRILLING CONTRACTOR: Connelly & Associates, Inc.		
OWNER/CLIENT: Kimley-Horn & Associates, Inc.		DRILLER: Z. Macomber	DATES DRILLED: 1/13/15 - 1/13/15	
PROJECT NUMBER: 14189	GROUND SURFACE ELEVATION (ft): NOT SURVEYED	DRILLING METHOD: 2.25" H.S.A	OFFSET NOTES:	

DEPTH (ft)	SAMPLE TYPE	STRATUM	GRAPHIC	MATERIAL DESCRIPTION	SOIL					
					SPT BLOW COUNTS	REC (ft)	STANDARD PENETRATION TEST RESISTANCE (BPF) 20 40 60 80			MC (%)
				Asphalt = 0.8ft.						
				<i>Potomac group</i> , orange - brown, f-c, clayey SAND with gravel, medium dense, moist, SC	4+7+6	15	●			7.6
5		D2		Dense	4+6+13	0	●			
					15+12+21	3	●			
10		E1		<i>Residual</i> , dark gray, f-m, clayey SAND, loose, moist, SC	5+4+3	4	●			
				Bottom of Boring at 10.0 ft						

GROUND WATER LEVELS: NOT ENCOUNTERED DURING DRILLING NOT ENCOUNTERED UPON COMPLETION CAVED: <u>4.0</u> ft	SAMPLE TYPES: <input checked="" type="checkbox"/> Split Spoon
--	--

REMARKS: Bulk sample collected from 0.0' to 5.0'

BOREHOLE/TEST PIT SEG. H&I LOGS.GPJ GEOCONCEPTS TEMPLATE 02-12-2015.GDT 4/22/16

PROJECT: Columbia Pike Multimodal Street Improvements		LOGGED BY: L. Pugh	BORING NUMBER: IB-10
LOCATION: Columbia Pike, Arlington , VA		DRILLING CONTRACTOR: Connelly & Associates, Inc.	
OWNER/CLIENT: Kimley-Horn & Associates, Inc.		DRILLER: Z. Macomber	DATES DRILLED: 1/15/15 - 1/15/15
PROJECT NUMBER: 14189	GROUND SURFACE ELEVATION (ft): NOT SURVEYED	DRILLING METHOD: 2.25" H.S.A	OFFSET NOTES:

DEPTH (ft)	SAMPLE TYPE	STRATUM	GRAPHIC	MATERIAL DESCRIPTION	SOIL		
					SPT BLOW COUNTS	REC (ft)	STANDARD PENETRATION TEST RESISTANCE (BPF) 20 40 60 80
				Asphalt = 0.5ft.			
				Crushed stone = 0.3ft.			
		D2		<i>Potomac group</i> , orange - brown, f-c, clayey SAND, micaceous, dense, moist, SC	15+20+12	1	●
				Brown, medium dense	16+6+7	18	●
5				With gravel	7+8+6	1	●
		E1		<i>Residual</i> , brown, f-m, clayey SAND, micaceous, loose, moist, SC	1+2+4	3	●
10				Bottom of Boring at 10.0 ft			

GROUND WATER LEVELS: NOT ENCOUNTERED DURING DRILLING NOT ENCOUNTERED UPON COMPLETION CAVED: <u>6.5</u> ft	SAMPLE TYPES: <input checked="" type="checkbox"/> Split Spoon
--	--

REMARKS:

THE STRATIFICATION LINES REPRESENT APPROXIMATE BOUNDARIES. THE TRANSITION MAY BE GRADUAL.

**Columbia Pike Multimodal Street Improvements
Arlington, Virginia**



Core #	Total Thickness (inch)	Asphalt Thickness (inch)	Concrete Thickness (inch)
AB-12	11.5	4.5	7.0

**Columbia Pike Multimodal Street Improvements
Arlington, Virginia**



Core #	Total Thickness (inch)	Asphalt Thickness (inch)	Concrete Thickness (inch)
AB-13	13.5	6.5	7.0

**Columbia Pike Multimodal Street Improvements
Arlington, Virginia**



Core #	Total Thickness (inch)	Asphalt Thickness (inch)	Concrete Thickness (inch)
AB-14	13.5	6.5	7.0

**Columbia Pike Multimodal Street Improvements
Arlington, Virginia**



Core #	Total Thickness (inch)	Asphalt Thickness (inch)	Concrete Thickness (inch)
AB-15	13.0	6.0	7.0

**Columbia Pike Multimodal Street Improvements
Arlington, Virginia**



Core #	Total Thickness (inch)	Asphalt Thickness (inch)	Concrete Thickness (inch)
AB-16	15.0	6.0	9.0

**Columbia Pike Multimodal Street Improvements
Arlington, Virginia**



Core #	Total Thickness (inch)	Asphalt Thickness (inch)	Concrete Thickness (inch)
CB-9	15.5	6.0	9.5

**Columbia Pike Multimodal Street Improvements
Arlington, Virginia**



Core #	Total Thickness (inch)	Asphalt Thickness (inch)	Concrete Thickness (inch)
CB-8	13.0	6.25	6.75

**Columbia Pike Multimodal Street Improvements
Arlington, Virginia**



Core #	Total Thickness (inch)	Asphalt Thickness (inch)	Concrete Thickness (inch)
CB-7	12.75	6.5	6.25

**Columbia Pike Multimodal Street Improvements
Arlington, Virginia**



Core #	Total Thickness (inch)	Asphalt Thickness (inch)	Concrete Thickness (inch)
CB-6	13.0	7.0	6.0

**Columbia Pike Multimodal Street Improvements
Arlington, Virginia**



Core #	Total Thickness (inch)	Asphalt Thickness (inch)	Concrete Thickness (inch)
CB-5	13.25	6.75	6.5

**Columbia Pike Multimodal Street Improvements
Arlington, Virginia**



Core #	Total Thickness (inch)	Asphalt Thickness (inch)	Concrete Thickness (inch)
CB-4	13.5	6.5	7.0

**Columbia Pike Multimodal Street Improvements
Arlington, Virginia**



Core #	Total Thickness (inch)	Asphalt Thickness (inch)	Concrete Thickness (inch)
CB-3	14.5	7.5	7.0

**Columbia Pike Multimodal Street Improvements
Arlington, Virginia**



Core #	Total Thickness (inch)	Asphalt Thickness (inch)	Concrete Thickness (inch)
CRW-2	14.0	7.5	6.5

**Columbia Pike Multimodal Street Improvements
Arlington, Virginia**



Core #	Total Thickness (inch)	Asphalt Thickness (inch)	Estimated Concrete Thickness (inch)
CRW-1	12.0	6.0	6.0*

* Estimated thickness, no recovery

**Columbia Pike Multimodal Street Improvements
Arlington, Virginia**



Core #	Total Thickness (inch)	Asphalt Thickness (inch)	Concrete Thickness (inch)
DB-11	8.5	2.75	5.75

**Columbia Pike Multimodal Street Improvements
Arlington, Virginia**



Core #	Total Thickness (inch)	Asphalt Thickness (inch)	Concrete Thickness (inch)
DB-10	12.0	3.5	8.5

**Columbia Pike Multimodal Street Improvements
Arlington, Virginia**



Core #	Total Thickness (inch)	Asphalt Thickness (inch)	Concrete Thickness (inch)
DB-9	13.0	2.5	10.5

**Columbia Pike Multimodal Street Improvements
Arlington, Virginia**



Core #	Total Thickness (inch)	Asphalt Thickness (inch)	Concrete Thickness (inch)
DB-8	8.5	3.25	5.25

**Columbia Pike Multimodal Street Improvements
Arlington, Virginia**



Core #	Total Thickness (inch)	Asphalt Thickness (inch)	Concrete Thickness (inch)
DB-7	10.0	3.75	6.25

**Columbia Pike Multimodal Street Improvements
Arlington, Virginia**



Core #	Total Thickness (inch)	Asphalt Thickness (inch)	Concrete Thickness (inch)
DB-6	9.75	3.5	6.25

**Columbia Pike Multimodal Street Improvements
Arlington, Virginia**



Core #	Total Asphalt Thickness (inch)	Subbase Material Type
DB-5	8.0	Crushed stone

**Columbia Pike Multimodal Street Improvements
Arlington, Virginia**



Core #	Total Asphalt Thickness (inch)	Subbase Material Type
DB-4	9.0	Crushed stone

**Columbia Pike Multimodal Street Improvements
Arlington, Virginia**



Core #	Total Thickness (inch)	Asphalt Thickness (inch)	Concrete Thickness (inch)
DB-3	7.75	2.25	5.5

**Columbia Pike Multimodal Street Improvements
Arlington, Virginia**



Core #	Total Thickness (inch)	Asphalt Thickness (inch)	Concrete Thickness (inch)
DB-2	10.5	4.5	6.0

**Columbia Pike Multimodal Street Improvements
Arlington, Virginia**



Core #	Total Thickness (inch)	Asphalt Thickness (inch)	Concrete Thickness (inch)
DB-1	9.75	3.0	6.75

**Columbia Pike Multimodal Street Improvements
Arlington, Virginia**



Core #	Total Thickness (inch)	Asphalt Thickness (inch)	Concrete Thickness (inch)
FRW-1	13.5	8.0	5.5

**Columbia Pike Multimodal Street Improvements
Arlington, Virginia**



Core #	Total Thickness (inch)	Asphalt Thickness (inch)	Concrete Thickness (inch)
FRW-2	15.5	8.5	7.0

**Columbia Pike Multimodal Street Improvements
Arlington, Virginia**



Core #	Total Thickness (inch)	Asphalt Thickness (inch)	Concrete Thickness (inch)
FRW-3	15.5	8.5	7.0

**Columbia Pike Multimodal Street Improvements
Arlington, Virginia**



Core #	Total Thickness (inch)	Asphalt Thickness (inch)	Concrete Thickness (inch)
FRW-4	15.5	8.5	7.0

**Columbia Pike Multimodal Street Improvements
Arlington, Virginia**



Core #	Total Thickness (inch)	Asphalt Thickness (inch)	Concrete Thickness (inch)
FRW-5	15.5	8.5	7.0

**Columbia Pike Multimodal Street Improvements
Arlington, Virginia**



Core #	Total Thickness (inch)	Asphalt Thickness (inch)	Concrete Thickness (inch)
FRW-6	13.0	7.0	6.0

**Columbia Pike Multimodal Street Improvements
Arlington, Virginia**



Core #	Total Thickness (inch)	Asphalt Thickness (inch)	Concrete Thickness (inch)
FRW-7	12.5	5.75	6.75

**Columbia Pike Multimodal Street Improvements
Arlington, Virginia**



Core #	Total Thickness (inch)	Asphalt Thickness (inch)	Concrete Thickness (inch)
FRW-8	15.0	8.0	7.0

**Columbia Pike Multimodal Street Improvements
Arlington, Virginia**



Core #	Total Asphalt Thickness (inch)	Subbase Material Type
FB-1	11.5	Crushed Stone

**Columbia Pike Multimodal Street Improvements
Arlington, Virginia**



Core #	Total Thickness (inch)	Asphalt Thickness (inch)	Concrete Thickness (inch)
FB-2	16.0	9.0	7.0

**Columbia Pike Multimodal Street Improvements
Arlington, Virginia**



Core #	Total Asphalt Thickness (inch)	Subbase Material Type
FB-3	8.5	Crushed Stone

**Columbia Pike Multimodal Street Improvements
Arlington, Virginia**



Core #	Total Thickness (inch)	Asphalt Thickness (inch)	Concrete Thickness (inch)
FB-4	16.0	9.0	7.0

**Columbia Pike Multimodal Street Improvements
Arlington, Virginia**



Core #	Total Asphalt Thickness (inch)	Subbase Material Type
FB-5	10.5	Crushed stone

**Columbia Pike Multimodal Street Improvements
Arlington, Virginia**



Core #	Total Thickness (inch)	Asphalt Thickness (inch)	Concrete Thickness (inch)
FB-6	15.5	7.75	7.75

**Columbia Pike Multimodal Street Improvements
Arlington, Virginia**



Core #	Total Thickness (inch)	Asphalt Thickness (inch)	Concrete Thickness (inch)
FB-7	14.5	8.0	6.5

**Columbia Pike Multimodal Street Improvements
Arlington, Virginia**



Core #	Total Thickness (inch)	Asphalt Thickness (inch)	Concrete Thickness (inch)
FB-8	14.0	7.5	6.5

**Columbia Pike Multimodal Street Improvements
Arlington, Virginia**



Core #	Total Thickness (inch)	Asphalt Thickness (inch)	Concrete Thickness (inch)
FB-9	13.5	6.75	6.75

**Columbia Pike Multimodal Street Improvements
Arlington, Virginia**



Core #	Total Thickness (inch)	Asphalt Thickness (inch)	Concrete Thickness (inch)
FB-10	12.5	5.25	7.25

**Columbia Pike Multimodal Street Improvements
Arlington, Virginia**



Core #	Total Thickness (inch)	Asphalt Thickness (inch)	Concrete Thickness (inch)
FB-11	10.75	3.75	7.0

**Columbia Pike Multimodal Street Improvements
Arlington, Virginia**



Core #	Total Thickness (inch)	Asphalt Thickness (inch)	Concrete Thickness (inch)
FB-12	11.0	4.25	6.75

**Columbia Pike Multimodal Street Improvements
Arlington, Virginia**



Core #	Total Thickness (inch)	Asphalt Thickness (inch)	Concrete Thickness (inch)
FB-13	11.75	4.5	7.25

**Columbia Pike Multimodal Street Improvements
Arlington, Virginia**



Core #	Total Thickness (inch)	Asphalt Thickness (inch)	Concrete Thickness (inch)
FB-14	13.5	6.5	7.0

**Columbia Pike Multimodal Street Improvements
Arlington, Virginia**



Core #	Total Thickness (inch)	Asphalt Thickness (inch)	Concrete Thickness (inch)
FB-15	12.0	5.25	6.75

**Columbia Pike Multimodal Street Improvements
Arlington, Virginia**



Core #	Total Thickness (inch)	Asphalt Thickness (inch)	Concrete Thickness (inch)
FB-16	8.5	2.25	6.25

**Columbia Pike Multimodal Street Improvements
Arlington, Virginia**



Core #	Total Thickness (inch)	Asphalt Thickness (inch)	Concrete Thickness (inch)
FB-17	12.5	5.75	6.75

**Columbia Pike Multimodal Street Improvements
Arlington, Virginia**



Core #	Total Thickness (inch)	Asphalt Thickness (inch)	Concrete Thickness (inch)
FB-18	13.5	6.5	7.0

**Columbia Pike Multimodal Street Improvements
Arlington, Virginia**

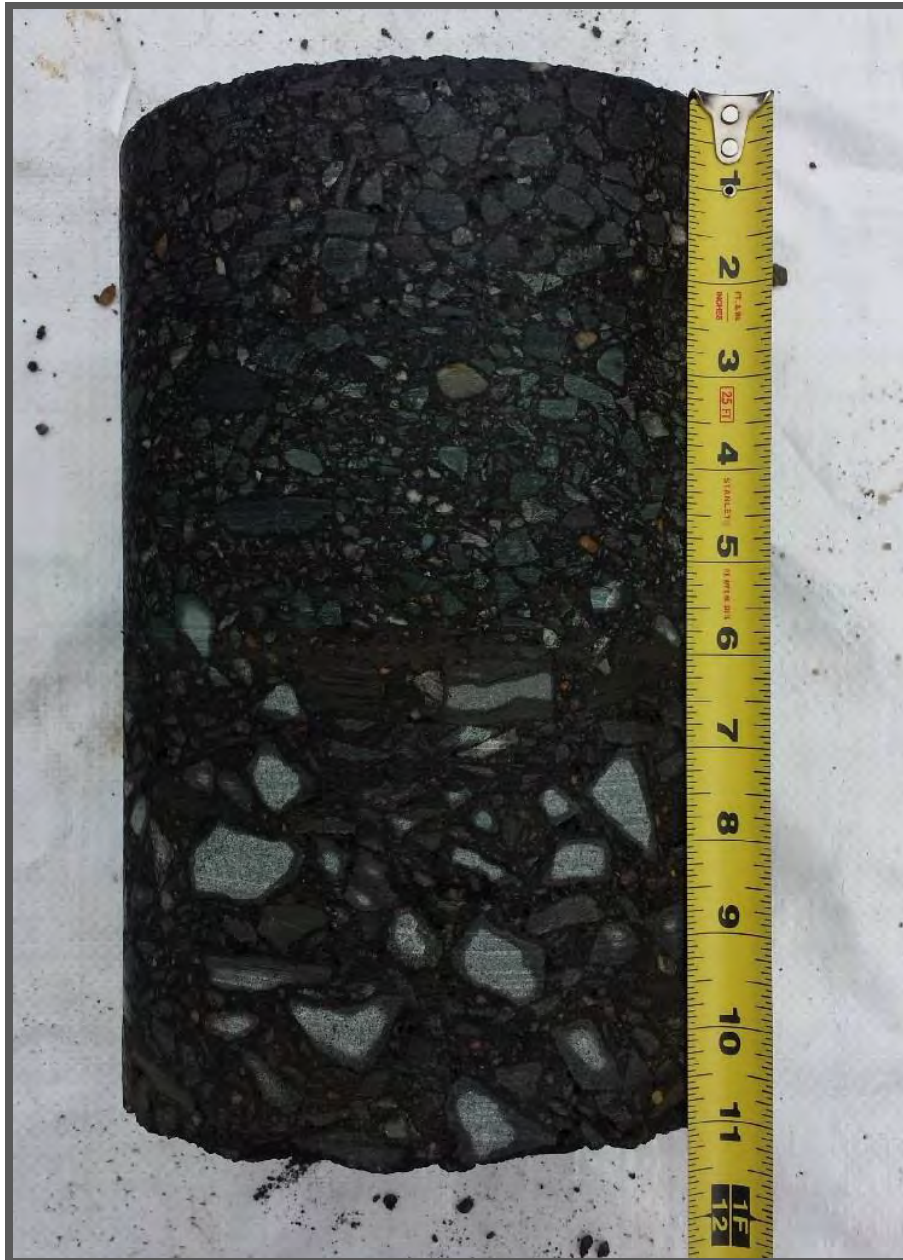

Core #	Total Asphalt Thickness (inch)	Subbase Material Type
FB-19	11.0	Crushed stone

**Columbia Pike Multimodal Street Improvements
Arlington, Virginia**



Core #	Total Thickness (inch)	Asphalt Thickness (inch)	Concrete Thickness (inch)
HB-7	13.0	6.25	6.75

**Columbia Pike Multimodal Street Improvements
Arlington, Virginia**



Core #	Total Thickness (inch)	Asphalt Thickness (inch)	Concrete Thickness (inch)
HB-6	13.0	6.75	6.25

**Columbia Pike Multimodal Street Improvements
Arlington, Virginia**



Core #	Total Thickness (inch)	Asphalt Thickness (inch)	Concrete Thickness (inch)
HB-3	12.5	5.0	7.5

**Columbia Pike Multimodal Street Improvements
Arlington, Virginia**



Core #	Total Thickness (inch)	Asphalt Thickness (inch)	Concrete Thickness (inch)
HB-2	13.0	6.0	7.0

**Columbia Pike Multimodal Street Improvements
Arlington, Virginia**



Core #	Total Thickness (inch)	Asphalt Thickness (inch)	Concrete Thickness (inch)
IB-1	12.5	6.0	6.5

**Columbia Pike Multimodal Street Improvements
Arlington, Virginia**



Core #	Total Asphalt Thickness (inch)	Subbase Material Type
IB-2	13.0	Crushed Stone

**Columbia Pike Multimodal Street Improvements
Arlington, Virginia**



Core #	Total Asphalt Thickness (inch)	Subbase Material Type
IB-10	8.5	Crushed Stone

**Columbia Pike Multimodal Street Improvements
Arlington, Virginia**



Core #	Total Asphalt Thickness (inch)	Subbase Material Type
IB-9	8.0	Crushed Stone

**Columbia Pike Multimodal Street Improvements
Arlington, Virginia**



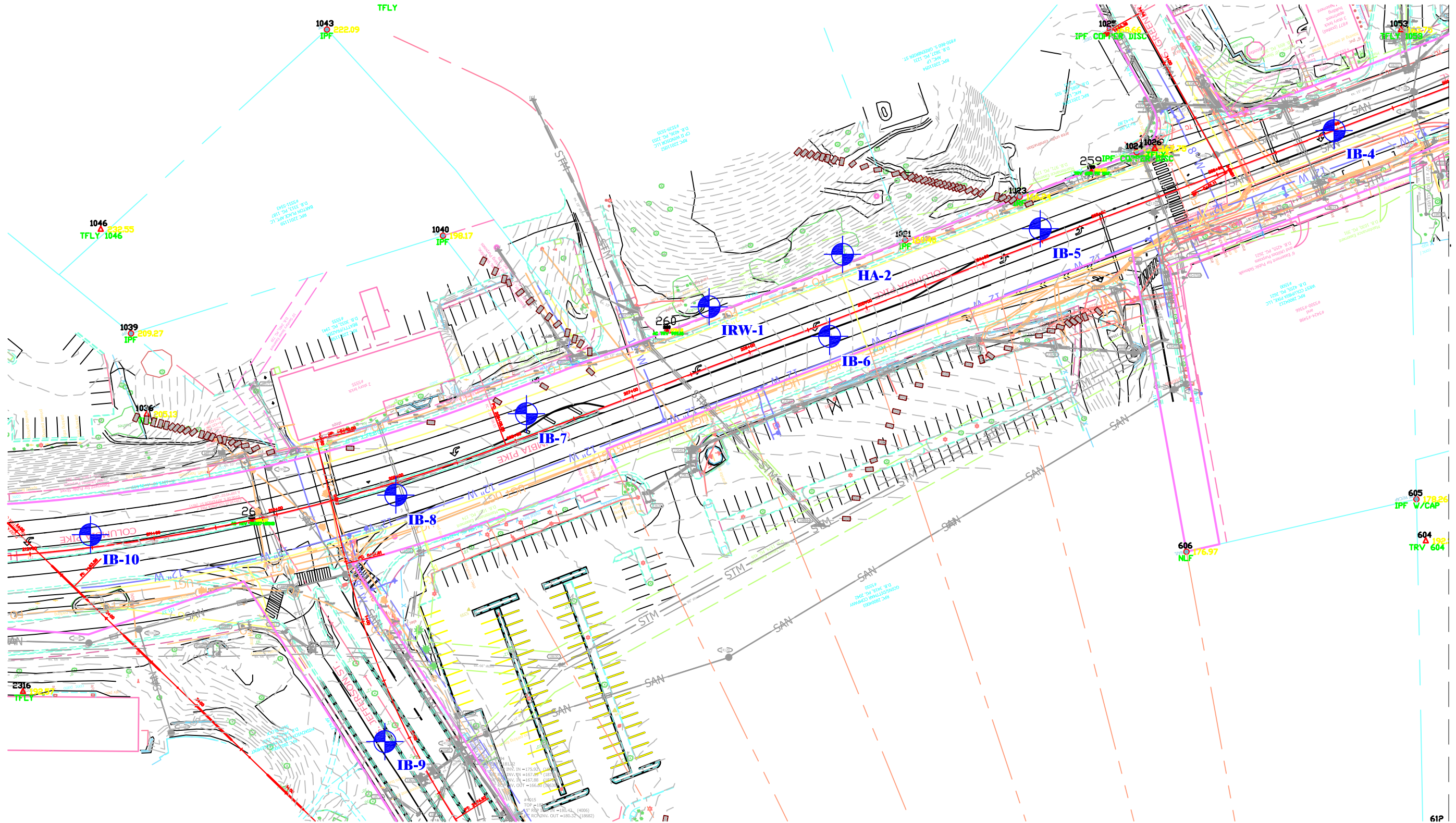

Core #	Total Asphalt Thickness (inch)	Subbase Material Type
IB-8	8.5	Crushed Stone

n:\projects\active 14 projects\14189, columbia pike\cad\segment final design drawings\geoconcepts boring location plan - segment h&i.dwg



L E G E N D

-  **IB-10** ROAD TEST BORING LOCATION
-  **IRW-1** RETAINING WALL TEST BORING LOCATION
-  **HA-2** HAND AUGER RETAINING WALL TEST BORING LOCATION

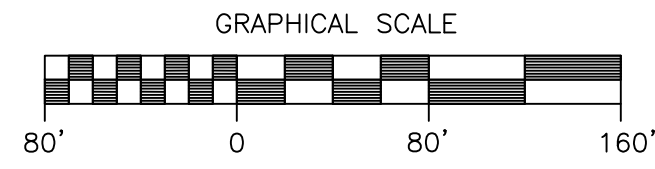

NOTE: BASE PLAN PROVIDED BY KIMLEY HORN DATED JANUARY 2015.

61P

MATCHLINE FIG. 3

 **GeoConcepts Engineering, Inc.**
 19955 Highland Vista Dr., Suite 170 (703) 726-8030
 Ashburn, Virginia 20147 (703) 726-8032 fax



COLUMBIA PIKE MULTIMODAL STREET IMPROVEMENTS ARLINGTON COUNTY, VIRGINIA			
BORING LOCATION PLAN SEGMENTS H&I		Scale: AS SHOWN	Fig. A.1
Date: APRIL 2016	Drawn By: F.S.M.	Checked By: P.E.B.	Project No.: 14189

n:\projects\active 14 projects\14189, columbia pike\cad\segment final design drawings\geoconcepts boring location plan - segment h&i.dwg



MATCHLINE FIG. 2

L E G E N D

-  **IB-3, HB-7** ROAD TEST BORING LOCATION
-  **IRW-3** RETAINING WALL TEST BORING LOCATION
-  **HA-3** HAND AUGER RETAINING WALL TEST BORING LOCATION

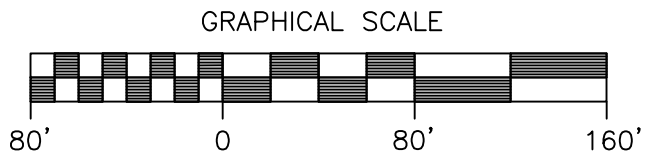



GeoConcepts Engineering, Inc.

19955 Highland Vista Dr., Suite 170 (703) 726-8030
 Ashburn, Virginia 20147 (703) 726-8032 fax

COLUMBIA PIKE MULTIMODAL STREET IMPROVEMENTS ARLINGTON COUNTY, VIRGINIA			
BORING LOCATION PLAN SEGMENTS H&I		Scale: AS SHOWN	Fig. A.2
Date: APRIL 2016	Drawn By: F.S.M.	Checked By: P.E.B.	Project No.: 14189

NOTE: BASE PLAN PROVIDED BY KIMLEY HORN DATED JANUARY 2015.

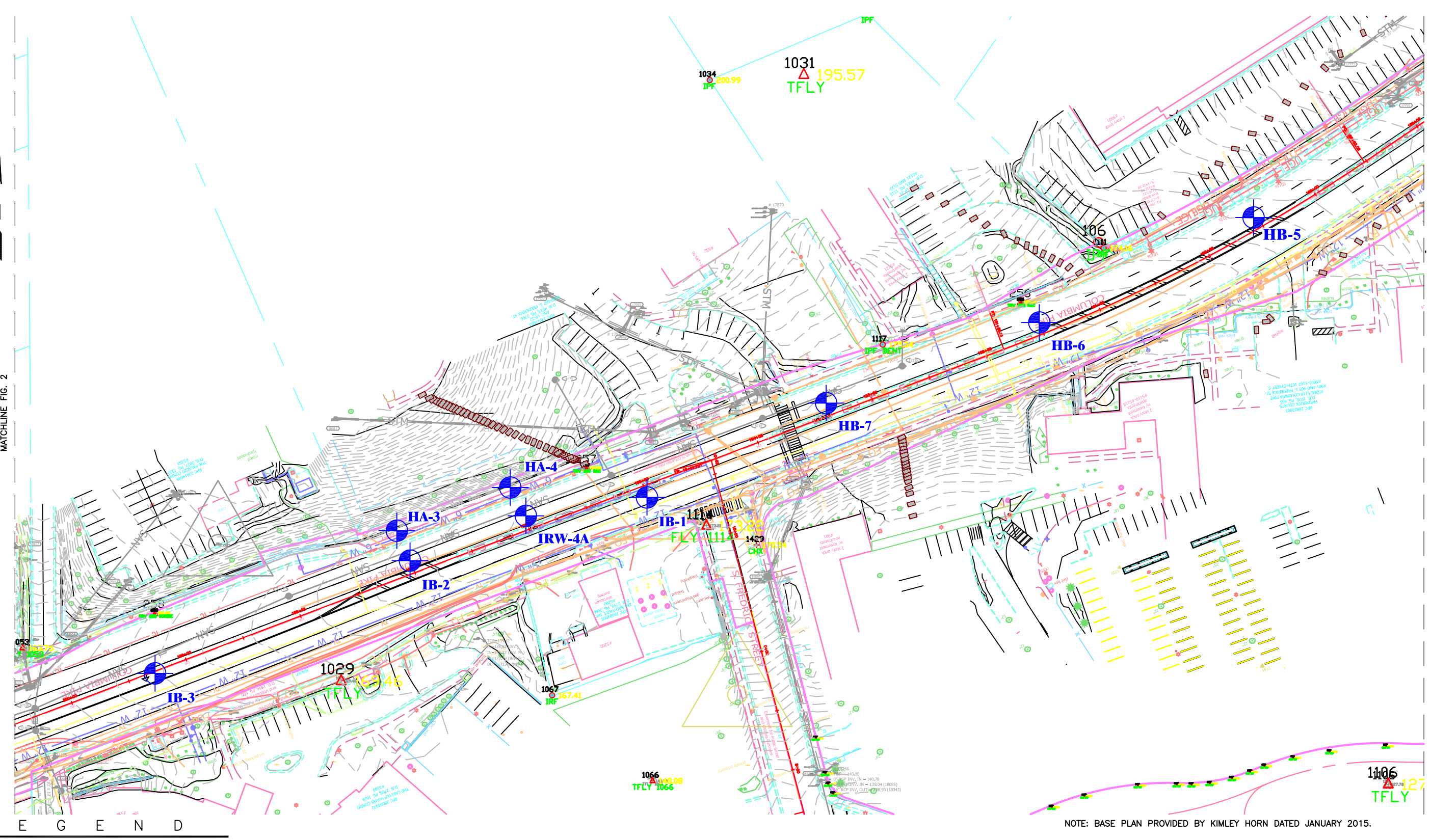
MATCHLINE FIG. 4



n:\projects\active 14 projects\14189, columbia pike\cad\segment final design drawings\geconcepts boring location plan - segment h&i.dwg

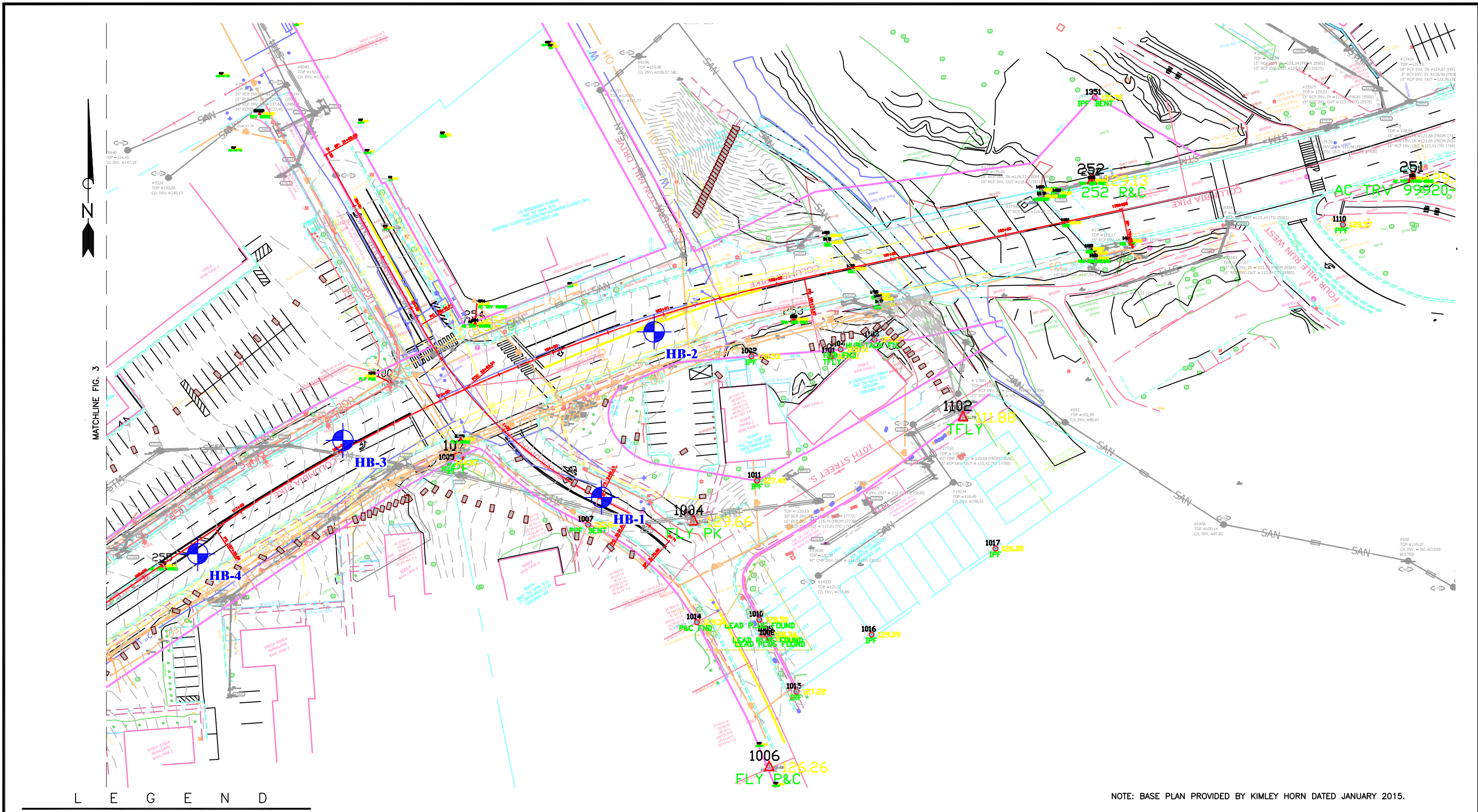

 ROAD TEST BORING LOCATION
HB-4

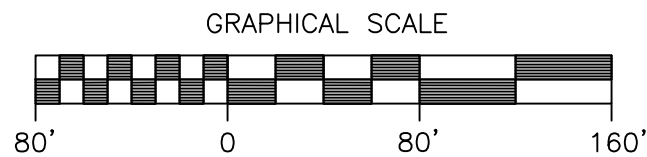



19955 Highland Vista Dr., Suite 170 (703) 726-8030
Ashburn, Virginia 20147 (703) 726-8032 fax

COLUMBIA PIKE MULTIMODAL STREET IMPROVEMENTS ARLINGTON COUNTY, VIRGINIA			
BORING LOCATION PLAN SEGMENTS H&I		Scale: AS SHOWN	Fig. A.3
Date: APRIL 2016	Drawn By: F.S.M.	Checked By: P.E.B.	Project No.: 14189



L E G E N D

-  ROAD TEST BORING LOCATION
- FB-18**
-  HAND AUGER ROAD TEST BORING LOCATION
- HA-19**

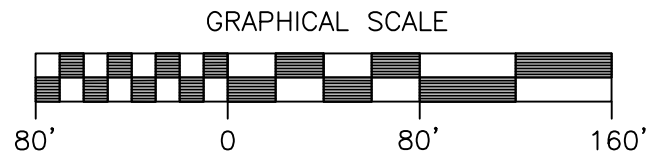

NOTE: BASE PLAN PROVIDED BY KIMLEY-HORN DATED JANUARY 2015.



GeoConcepts Engineering, Inc.

19955 Highland Vista Dr., Suite 170 (703) 726-8030
 Ashburn, Virginia 20147 (703) 726-8032 fax

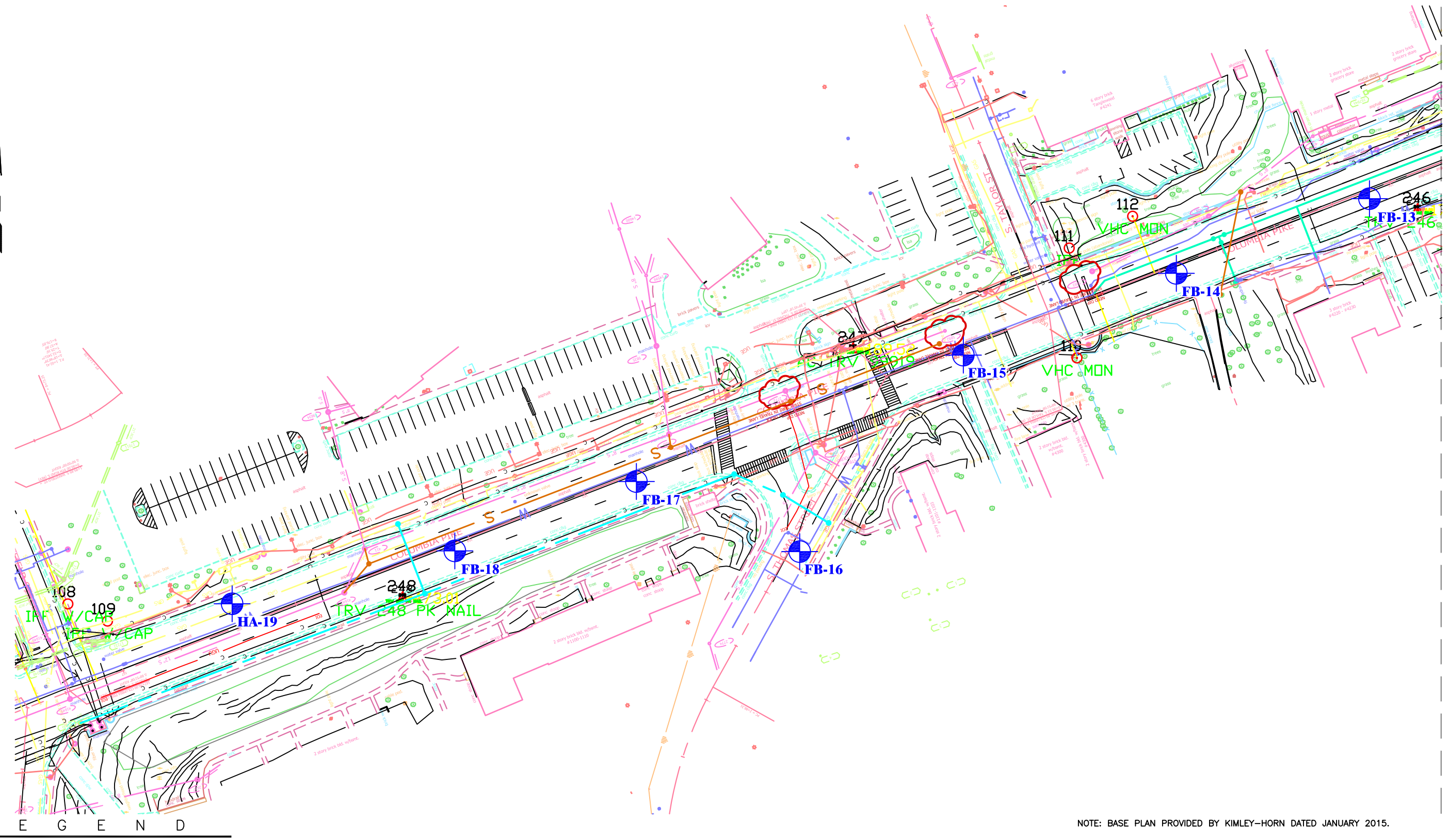

COLUMBIA PIKE MULTIMODAL STREET IMPROVEMENTS ARLINGTON COUNTY, VIRGINIA			
BORING LOCATION PLAN SEGMENT F		Scale: AS SHOWN	Fig. A.4
Date: APRIL 2016	Drawn By: F.S.M.	Checked By: P.E.B.	Project No.: 14189

MATCHLINE FIG. 6

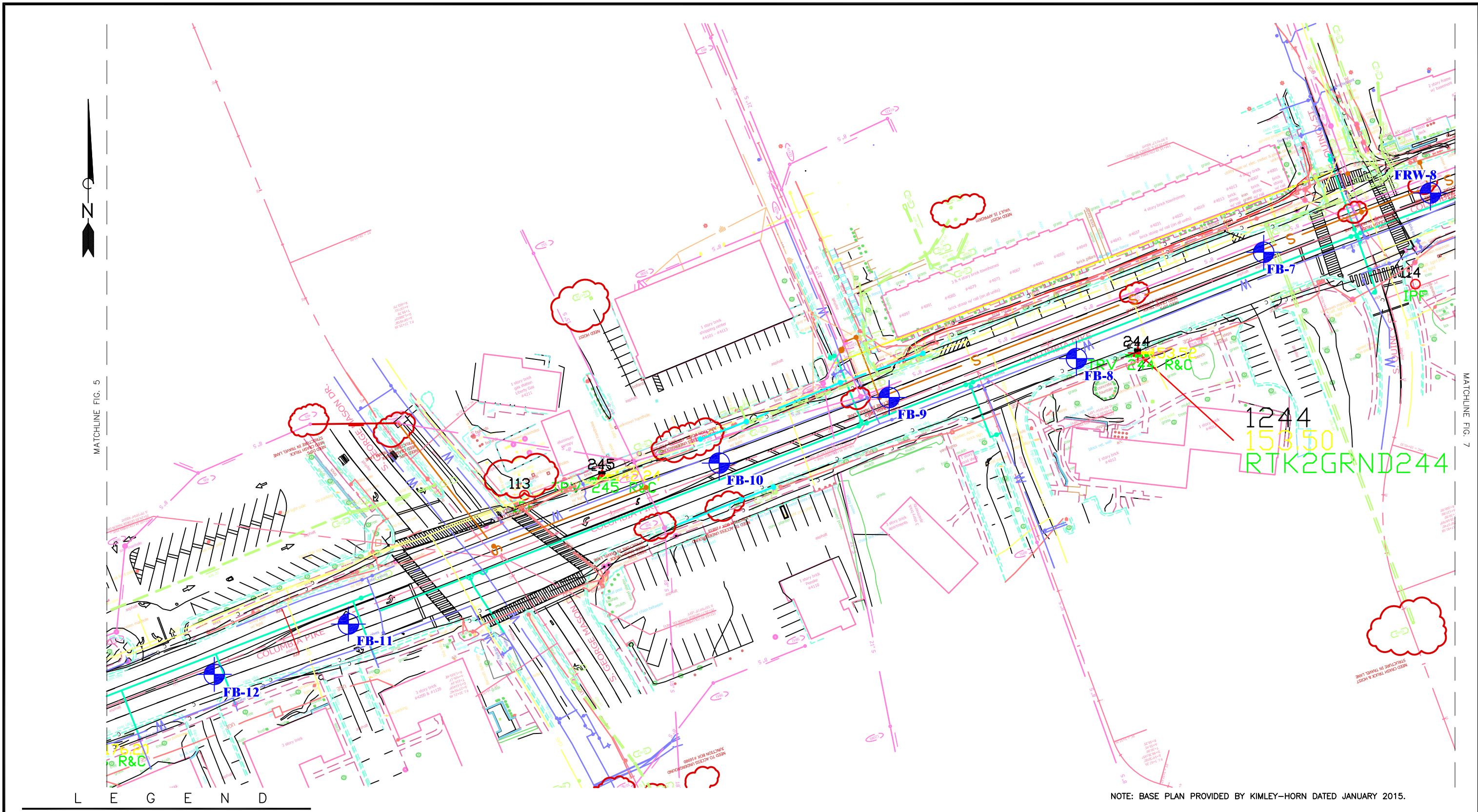



NOTE: BASE PLAN PROVIDED BY KIMLEY-HORN DATED JANUARY 2015.

-  ROAD TEST BORING LOCATION
- FB-12**
-  RETAINING WALL TEST BORING LOCATION
- FRW-8**

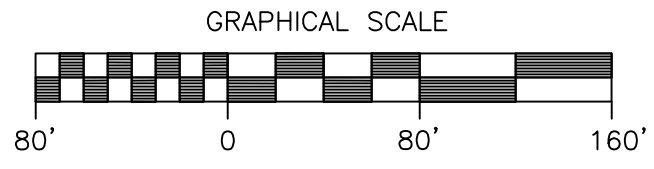



GeoConcepts Engineering, Inc.

19955 Highland Vista Dr., Suite 170 (703) 726-8030
 Ashburn, Virginia 20147 (703) 726-8032 fax

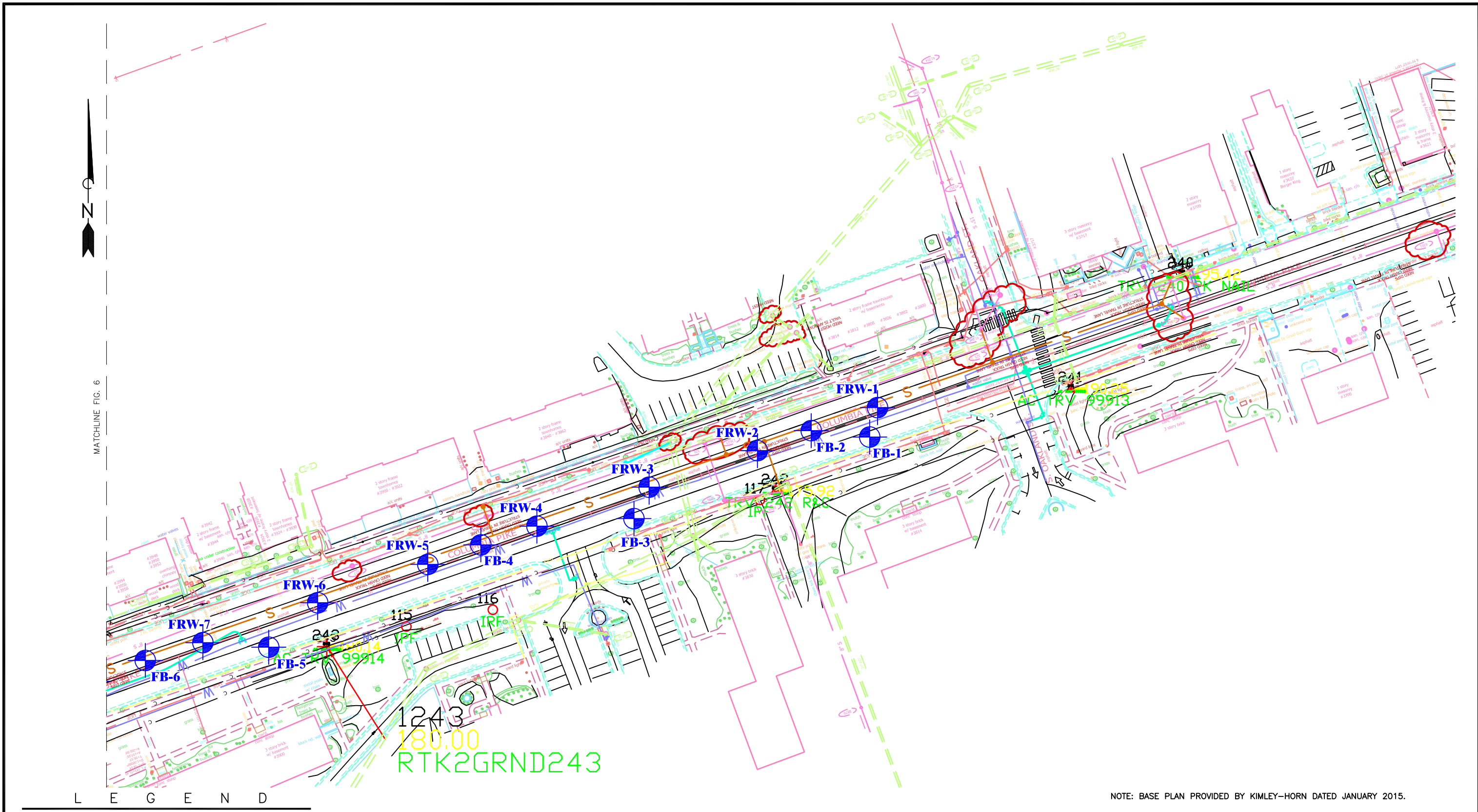
COLUMBIA PIKE MULTIMODAL STREET IMPROVEMENTS ARLINGTON COUNTY, VIRGINIA			
BORING LOCATION PLAN SEGMENT F		Scale: AS SHOWN	Fig. A.5
Date: APRIL 2016	Drawn By: F.S.M.	Checked By: P.E.B.	Project No.: 14189



- LEGEND**
-  ROAD TEST BORING LOCATION
FB-6
 -  RETAINING WALL TEST BORING LOCATION
FRW-7

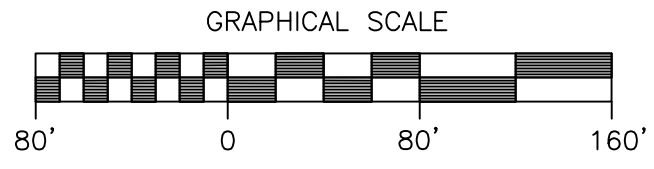

GeoConcepts Engineering, Inc.

19955 Highland Vista Dr., Suite 170 (703) 726-8030
 Ashburn, Virginia 20147 (703) 726-8032 fax

COLUMBIA PIKE MULTIMODAL STREET IMPROVEMENTS ARLINGTON COUNTY, VIRGINIA			
BORING LOCATION PLAN SEGMENT F		Scale: AS SHOWN	Fig. A.6
Date: APRIL 2016	Drawn By: F.S.M.	Checked By: P.E.B.	Project No.: 14189

n:\projects\active 14 projects\14189, columbia pike\cad\segment final design drawings\geoconcepts boring location plan - seg d.dwg



L E G E N D

 ROAD TEST BORING LOCATION
DB-11

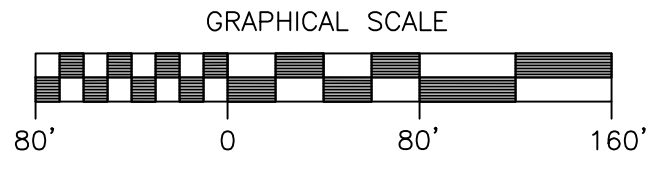

NOTE: BASE PLAN PROVIDED BY KIMLEY-HORN DATED JANUARY 2015.

MATCHLINE FIG. 9

 **GeoConcepts Engineering, Inc.**
19955 Highland Vista Dr., Suite 170 (703) 726-8030
Ashburn, Virginia 20147 (703) 726-8032 fax

COLUMBIA PIKE MULTIMODAL STREET IMPROVEMENTS ARLINGTON COUNTY, VIRGINIA			
BORING LOCATION PLAN SEGMENT D		Scale: AS SHOWN	Fig. A.7
Date: APRIL 2016	Drawn By: F.S.M.	Checked By: P.E.B.	Project No.: 14189

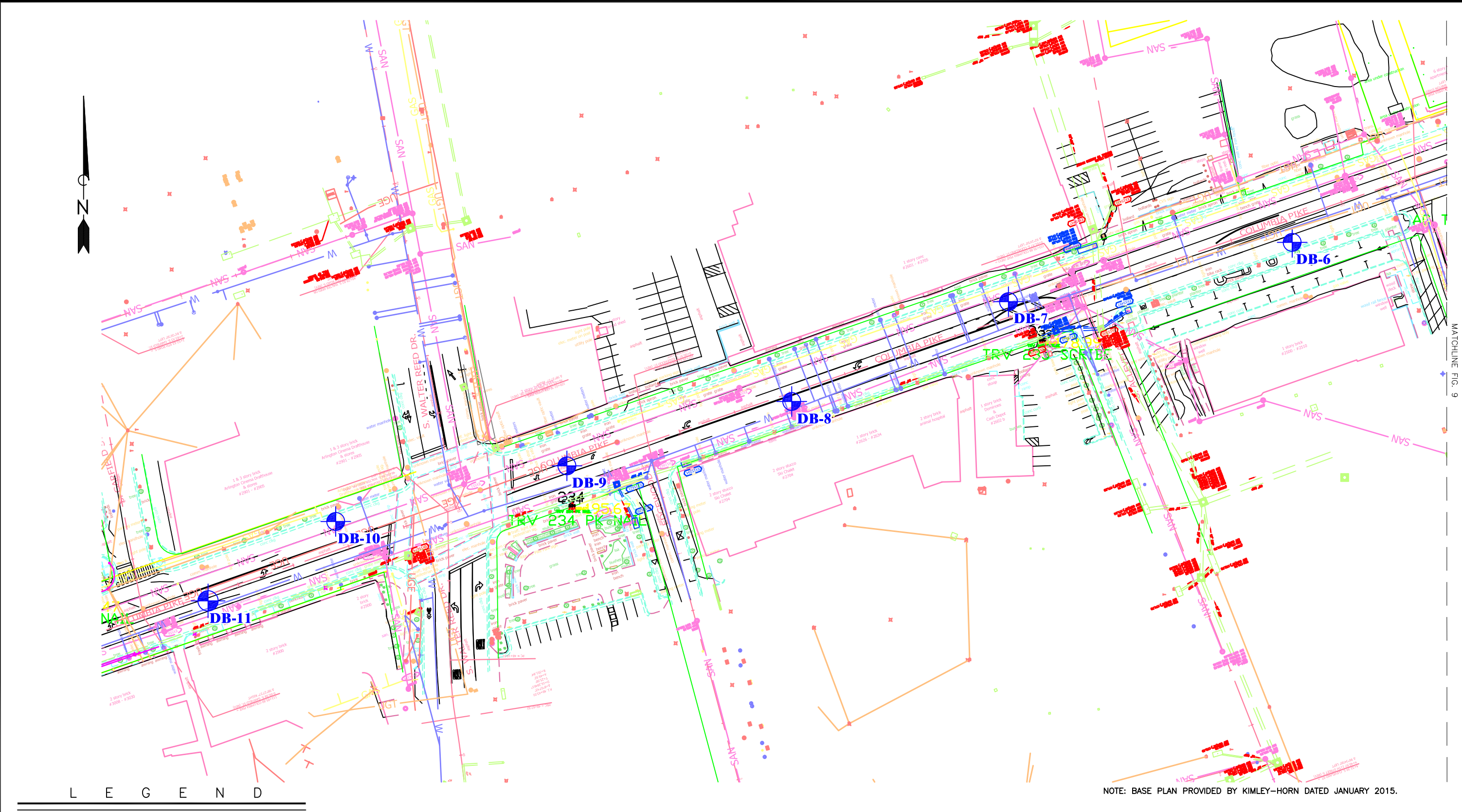

n:\projects\active 14 projects\14189, columbia pike\cad\segment final design drawings\geoconcepts boring location plan - seg d.dwg

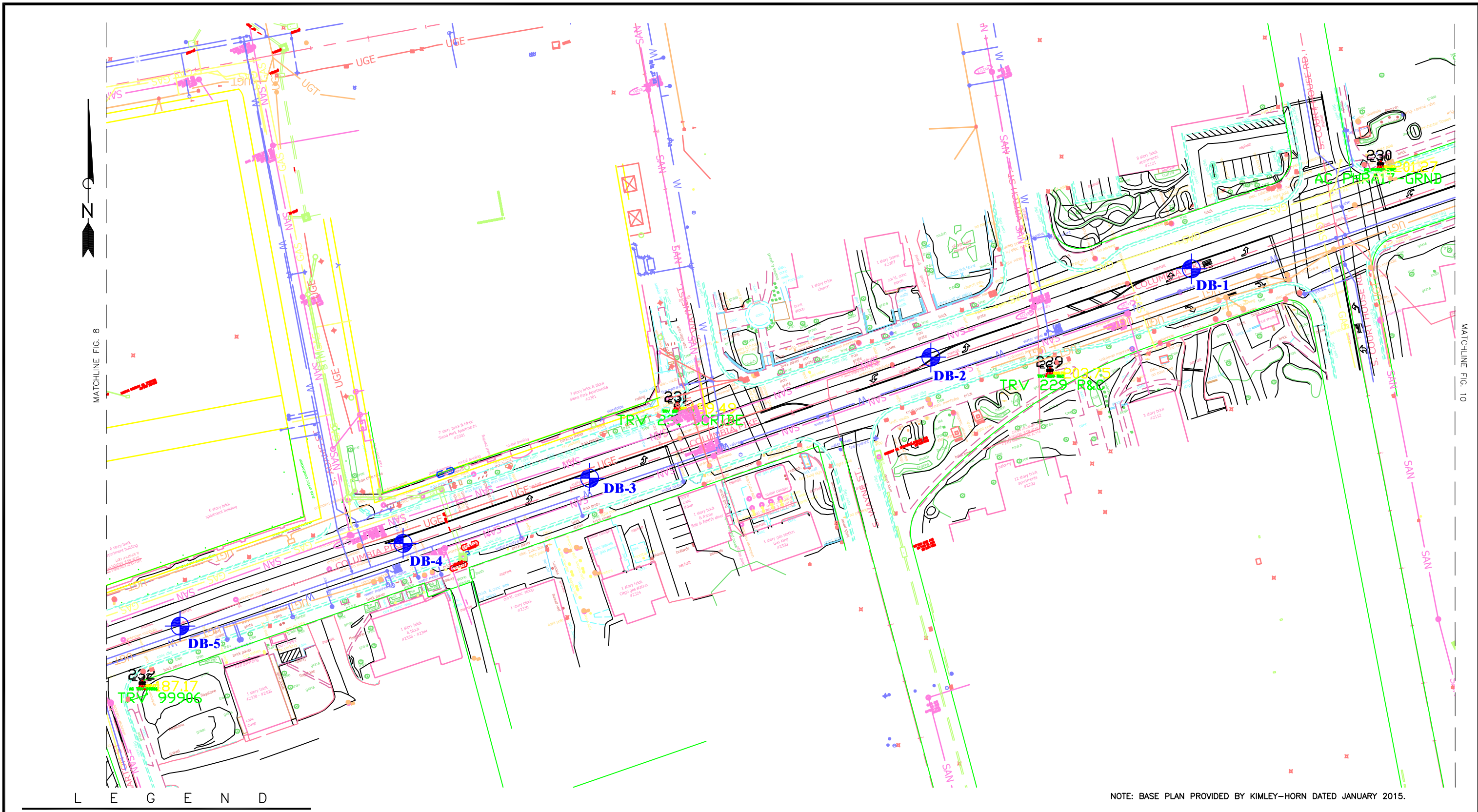

MATCHLINE FIG. 8

MATCHLINE FIG. 10

L E G E N D

NOTE: BASE PLAN PROVIDED BY KIMLEY-HORN DATED JANUARY 2015.



DB-5

ROAD TEST BORING LOCATION

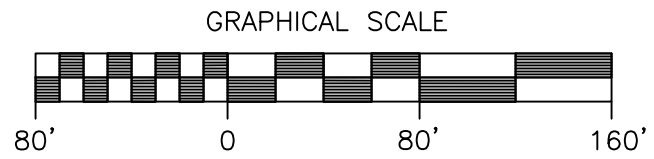

GeoConcepts Engineering, Inc.

19955 Highland Vista Dr., Suite 170 (703) 726-8030
 Ashburn, Virginia 20147 (703) 726-8032 fax

COLUMBIA PIKE MULTIMODAL STREET IMPROVEMENTS ARLINGTON COUNTY, VIRGINIA			
BORING LOCATION PLAN SEGMENT D		Scale: AS SHOWN	Fig. A.8
Date: APRIL 2016	Drawn By: F.S.M.	Checked By: P.E.B.	Project No.: 14189



MATCHLINE FIG. 9

L E G E N D



CB-9

ROAD TEST BORING LOCATION

GRAPHICAL SCALE

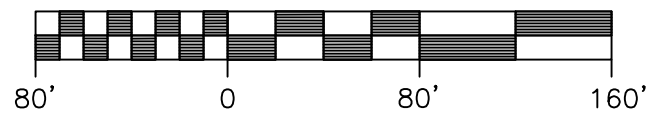

NOTE: BASE PLAN PROVIDED BY KIMLEY-HORN DATED JANUARY 2015.



MATCHLINE FIG. 11

GeoConcepts Engineering, Inc.
 19955 Highland Vista Dr., Suite 170 (703) 726-8030
 Ashburn, Virginia 20147 (703) 726-8032 fax

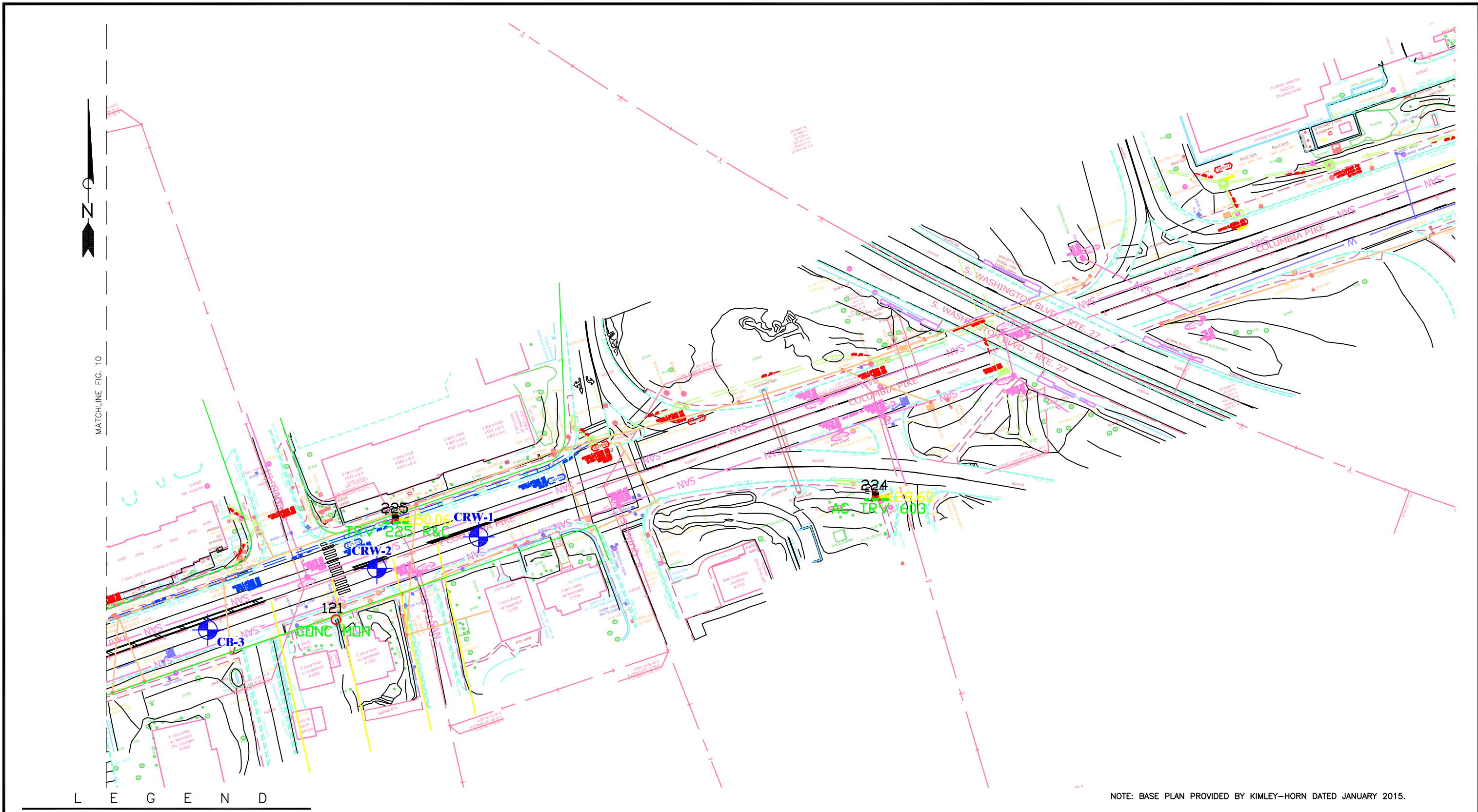
COLUMBIA PIKE MULTIMODAL STREET IMPROVEMENTS ARLINGTON COUNTY, VIRGINIA			
BORING LOCATION PLAN SEGMENT C		Scale: AS SHOWN	Fig. A.9
Date: APRIL 2016	Drawn By: F.S.M.	Checked By: P.E.B.	Project No.: 14189



NOTE: BASE PLAN PROVIDED BY KIMLEY-HORN DATED JANUARY 2015.

-  ROAD TEST BORING LOCATION
- CB-3**
-  RETAINING WALL TEST BORING LOCATION
- CRW-2**

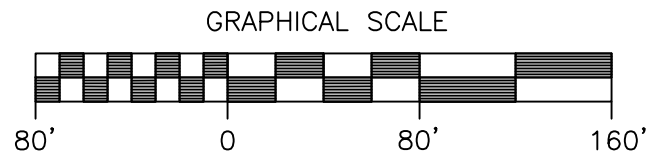

 **GeoConcepts Engineering, Inc.**
 19955 Highland Vista Dr., Suite 170 (703) 726-8030
 Ashburn, Virginia 20147 (703) 726-8032 fax

COLUMBIA PIKE MULTIMODAL STREET IMPROVEMENTS ARLINGTON COUNTY, VIRGINIA			
BORING LOCATION PLAN SEGMENT C		Scale: AS SHOWN	Fig. A.10
Date: APRIL 2016	Drawn By: F.S.M.	Checked By: P.E.B.	Project No.: 14189

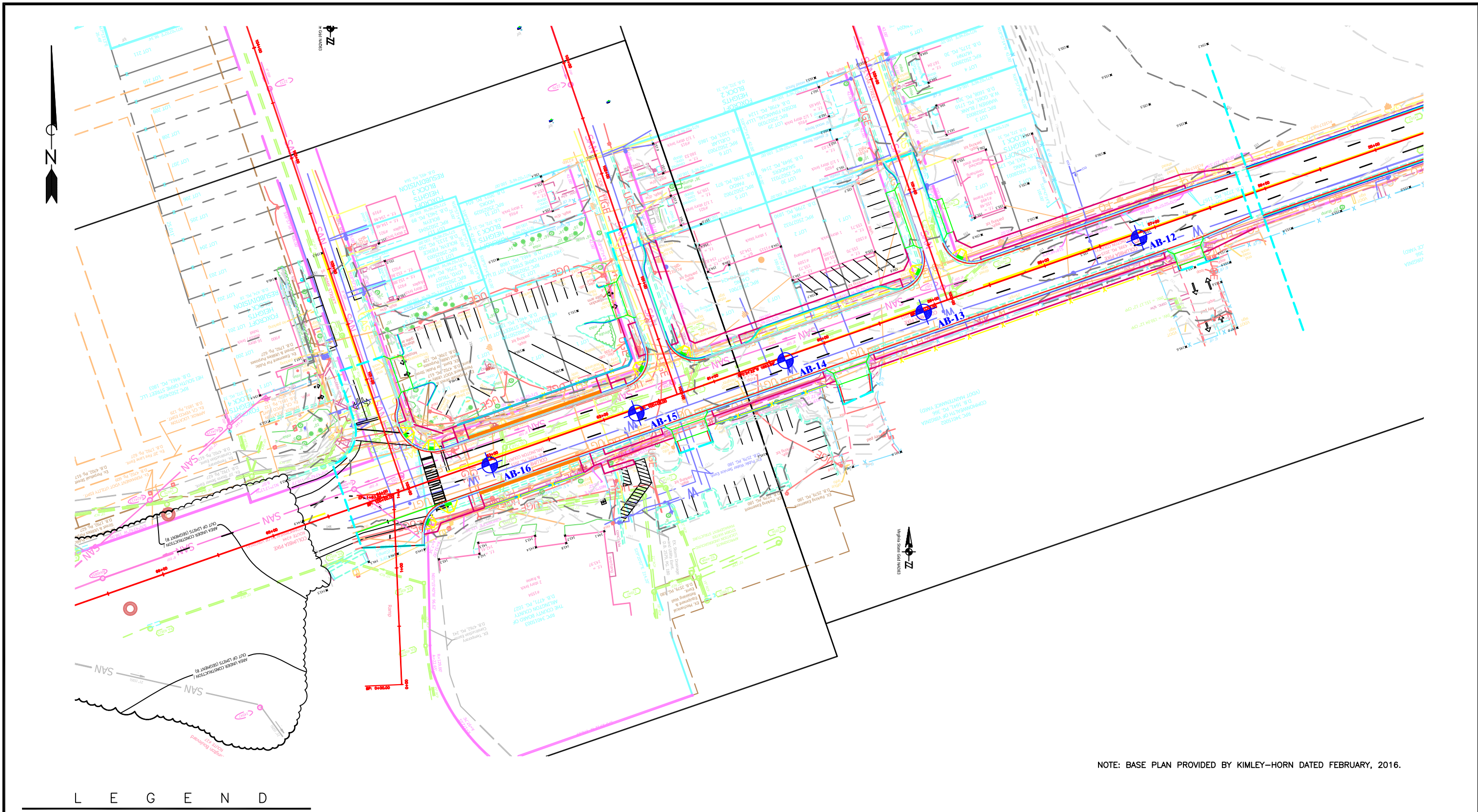

NOTE: BASE PLAN PROVIDED BY KIMLEY-HORN DATED FEBRUARY, 2016.

L E G E N D

 ROAD TEST BORING LOCATION
AB-12

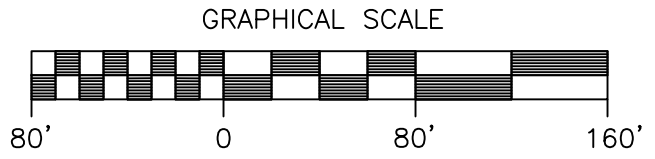

19955 Highland Vista Dr., Suite 170 (703) 726-8030
 Ashburn, Virginia 20147 (703) 726-8032 fax

COLUMBIA PIKE MULTIMODAL STREET IMPROVEMENTS ARLINGTON, VIRGINIA			
BORING LOCATION PLAN SEGMENT A		Scale: AS SHOWN	Fig. A.11
Date: APRIL 2016	Drawn By: F.S.M.	Checked By: P.E.B.	Project No.: 14189

Appendix B

Soil Laboratory Test Results

Table B-1: Summary of Soil Laboratory Test Results (1 page)

Liquid Limit and Grain Size Analysis Test Data (44 pages)

Moisture Density Relationship Test Data (14 pages)

CBR Test Data (14 pages)

Table B-1: Summary of Soil Laboratory Test Results

Project: Columbia Pike Multimodal Street Improvements, Arlington, Virginia

Contract No.: 14189

Test Boring No.	Depth	Sample	Stratum	Description of Soil Specimen	Sieve Results		Atterberg Limits			Natural Moisture Content (%)	Remarks
					Percent Retained # 4 Sieve	Percent Passing # 200 Sieve	LL	PL	PI		
AB-12	0.0-5.0	Bulk	A	clayey SAND (SC)	5.5	31.8	50	24	26	16.1	CBR=12.1%
AB-12	5.0-7.0	Split-Spoon	A	clayey SAND (SC)	1.5	26.4	48	24	24	14.9	--
AB-12	23.0-25.0	Split-Spoon	C2	WELL GRADED SAND with clay and gravel (SW-SC)	43.5	9.6	30	18	12	7.0	--
AB-13	3.0-5.0	Split-Spoon	C1	sandy LEAN CLAY (CL)	1.3	64.8	24	17	7	13.7	--
AB-15	0.0-5.0	Bulk	A/C2	clayey SAND (SC)	11.7	30.8	37	17	20	10.1	CBR=13.7%
AB-16	7.3-9.3	Split-Spoon	C1	Sandy Silty CLAY (CL-ML)	8.6	58.7	22	18	4	18.5	--
CRW-2	0.0-5.0	Bulk	A	clayey SAND (SC)	9.9	44.9	34	15	19	14.2	CBR=4.7%
CB-3	1.0-2.5	Split-Spoon	C1	sandy silty CLAY with gravel (CL-ML)	16.6	64.0	21	15	6	14.4	--
CB-5	0.0-5.0	Bulk	C1	sandy LEAN CLAY (CL)	14.3	59.1	41	18	23	9.7	CBR=2.1%
CB-8	0.0-5.0	Bulk	C2	clayey SAND (SC)	5.3	42.1	30	15	15	16.6	CBR=1.6%
DB-2	0.0-5.0	Bulk	C1	sandy FAT CLAY with gravel (CH)	18.2	61.2	51	21	30	17.5	CBR=2.5%
DB-4	5.0-6.5	Split-Spoon	A	clayey GRAVEL with sand (GC)	43.3	22.2	32	16	16	13.4	--
DB-6	0.0-5.0	Bulk	C2	clayey SAND with gravel (SC)	15.1	32.1	31	15	16	11.0	CBR=9.0%
DB-10	0.0-5.0	Bulk	C2	clayey SAND (SC)	2.1	44.4	27	14	13	16.1	CBR=16.0%
FRW-6	5.0-6.5	Split-Spoon	D1	FAT CLAY (CH)	0.0	93.6	71	27	44	37.2	--
FB-2	0.0-5.0	Bulk	D2	clayey SAND with gravel (SC)	16.4	26.8	72	26	46	6.2	CBR=9.9%
FB-9	0.0-5.0	Bulk	B	sandy LEAN CLAY (CL)	8.8	51.1	36	19	17	14.5	CBR=4.3%
FB-18	0.0-5.0	Bulk	C1	LEAN CLAY (CL)	0.1	86.7	25	17	8	18.6	CBR=2.3%
HB-5	0.0-5.0	Bulk	D2	clayey SAND (SC)	5.0	29.0	74	20	54	17.3	CBR=8.0%
IRW-1	5.0-6.5	Split-Spoon	E1	silty SAND (SM)	0	21.3	53	33	20	18.7	--
IB-2	0.0-5.0	Bulk	D1	sandy FAT CLAY (CH)	1.8	51	53	20	33	24.7	CBR=4.3%
IB-9	0.0-5.0	Bulk	D2	clayey SAND with gravel (SC)	26.2	31.7	44	15	29	7.6	CBR=8.8%

Notes:

1. Soil tests are in accordance with applicable ASTM standards.
2. Soil classification symbols are in accordance with Unified Soil Classification System.
3. Key to abbreviations: LL= Liquid Limit; PL= Plastic Limit; PI= Plasticity Index; NP= Nonplastic; N/T= Not Tested
4. CBR values correspond to 0.1 inch penetration resistance of soil sample compacted to 95% of maximum dry density



LIQUID AND PLASTIC LIMIT - ASTM D4318			
Project No.	14189	Project Name	Columbia Pike Multimodal St. Improvements
Test Boring No.	AB-12	Depth (Feet)	0.0'-5.0'
Lab Order No.	3754-2	Date	3/17/2016

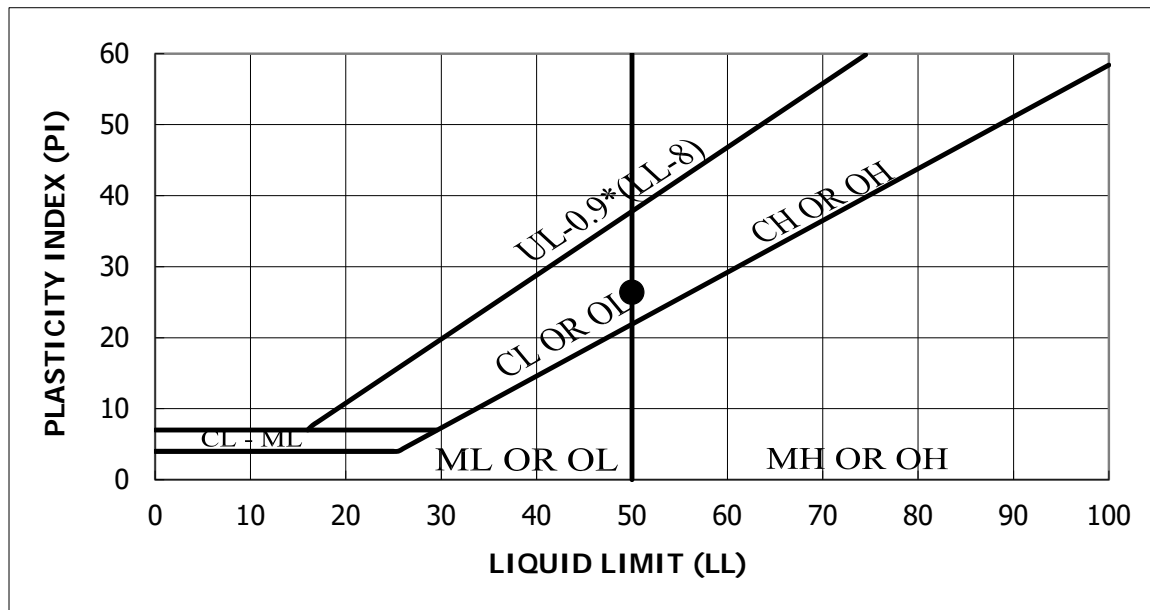

Material Description	LL	PL	PI	% Passing		USCS	w (%)
				#4	#200		
CLAYEY SAND	50	24	26	94.5	31.8	SC	16.1
Color	Brown		AASHTO Classification		A-2-7		

Test Method: ASTM D 4318
Soil Classification by ASTM D2487 and AASHTO M 145

Reviewed by Lindsay Bantz



GRAIN SIZE ANALYSIS - ASTM D422			
Project No.	14189	Project Name	Columbia Pike Multimodal St. Improvements
Test Boring No.	AB-12	Depth (Feet)	0.0'-5.0'
Lab Order No.	3754-2	Date	3/17/2016

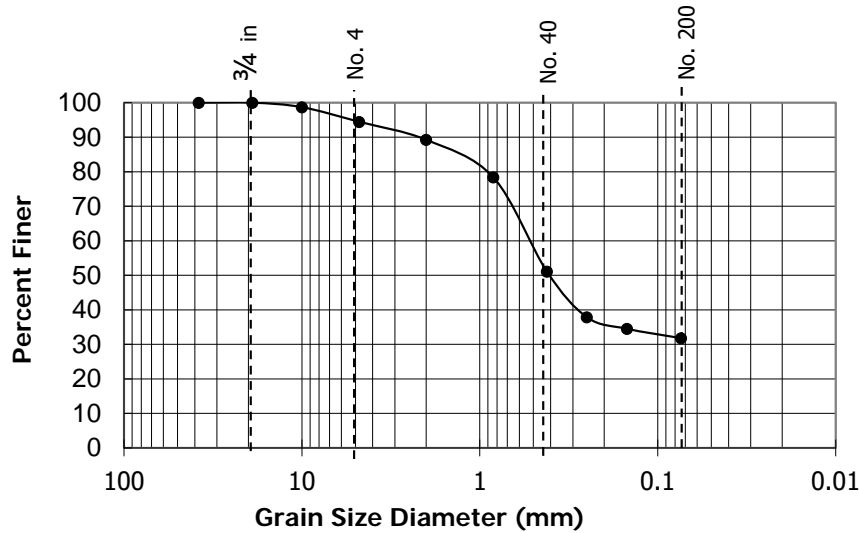

SIEVE	% Passing
1 1/2 "	100
3/4"	100
3/8"	99
#4	94
#10	89
#20	78
#40	51
#60	38
#100	35
#200	32
Pan	--

USCS Group Symbol	SC
USCS Group Name	CLAYEY SAND
Cu	---
Cc	---
LL	50
PI	26
Gravel	5.5
Sand	62.7
Fines	31.8
AASHTO Classification	A-2-7
Color	Brown

Test Method: ASTM D 422

Soil Classification by ASTM D2487 and AASHTO M 145

Reviewed by:

Lindsay Bantz



LIQUID AND PLASTIC LIMIT - ASTM D4318			
Project No.	14189	Project Name	Columbia Pike Multimodal Street Improvements
Test Boring No.	AB-12	Depth (Feet)	5.0-7.0
Lab Order No.	3754-1	Date	3/22/2016

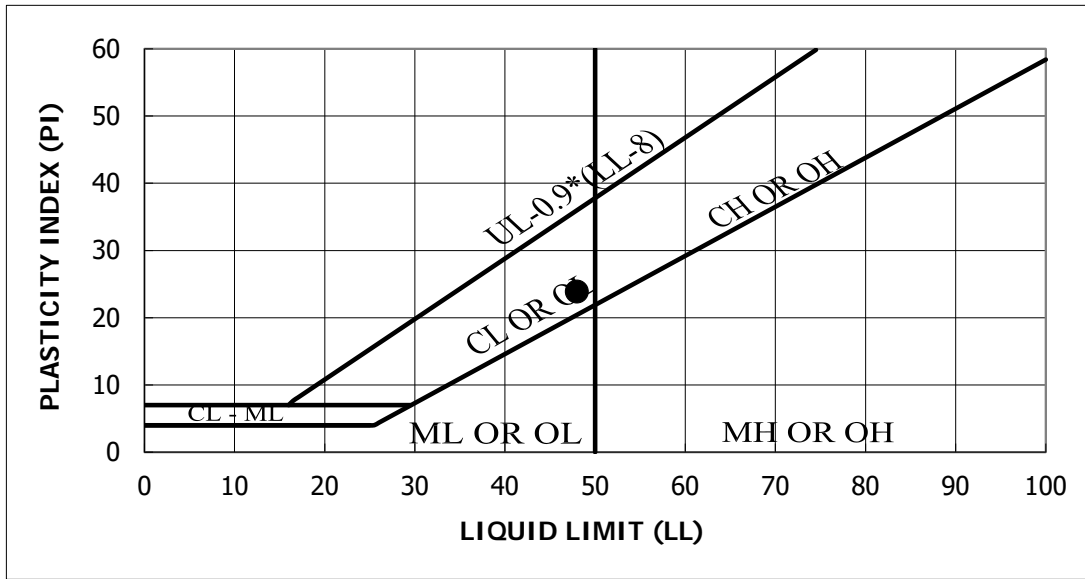

Material Description	LL	PL	PI	% Passing		USCS	w (%)
				#4	#200		
CLAYEY SAND	48	24	24	98.5	26.4	SC	14.9
Color	Reddish Brown		AASHTO Classification			A-2-7	

Test Method: ASTM D 4318
Soil Classification by ASTM D2487 and AASHTO M 145

Reviewed by Lindsay Bartz



GRAIN SIZE ANALYSIS - ASTM D422

Project No.	14189	Project Name	Columbia Pike Multimodal Street Improvements
Test Boring No.	AB-12	Depth (Feet)	5.0-7.0
Lab Order No.	3754-1	Date	3/22/2016

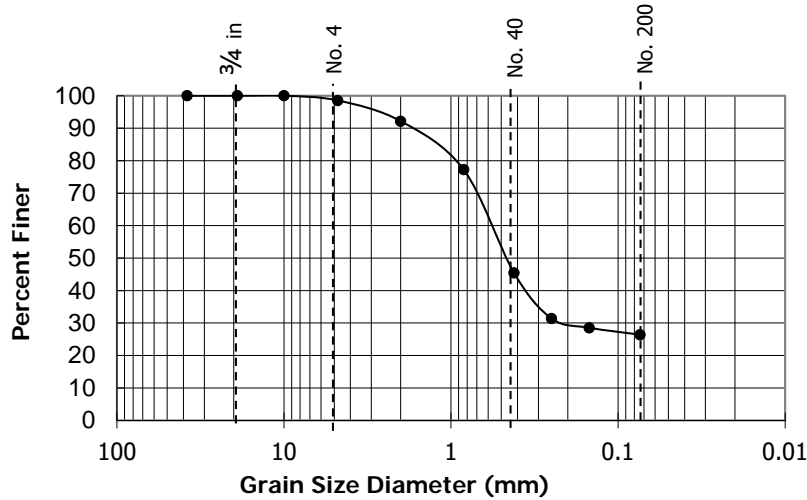

SIEVE	% Passing
1 1/2 "	100
3/4"	100
3/8"	100
#4	99
#10	92
#20	77
#40	45
#60	31
#100	29
#200	26
Pan	--

USCS Group Symbol	SC
USCS Group Name	CLAYEY SAND
Cu	---
Cc	---
LL	48
PI	24
Gravel	1.5
Sand	72.1
Fines	26.4
AASHTO Classification	A-2-7
Color	Reddish Brown

Test Method: ASTM D 422

Soil Classification by ASTM D2487 and AASHTO M 145

Reviewed by:

Lindsay Bantz



LIQUID AND PLASTIC LIMIT - ASTM D4318			
Project No.	14189	Project Name	Columbia Pike Multimodal Street Improvements
Test Boring No.	AB-12	Depth (Feet)	23.0-25.0
Lab Order No.	3754-3	Date	3/22/2016

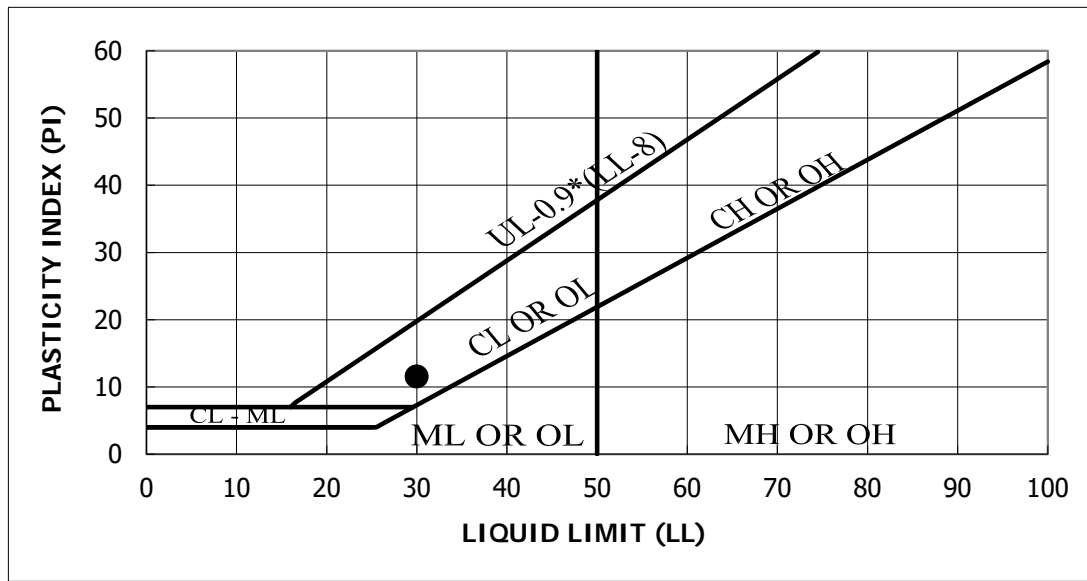

Material Description	LL	PL	PI	% Passing		USCS	w (%)
				#4	#200		
WELL GRADED SAND with clay and gravel	30	18	12	56.5	9.6	SW-SC	7.0
Color	Brown		AASHTO Classification		A-2-6		

Test Method: ASTM D 4318

Soil Classification by ASTM D2487 and AASHTO M 145

Reviewed by Lindsay Bantz



GRAIN SIZE ANALYSIS - ASTM D422			
Project No.	14189	Project Name	Columbia Pike Multimodal Street Improvements
Test Boring No.	AB-12	Depth (Feet)	23.0-25.0
Lab Order No.	3754-3	Date	3/22/2016

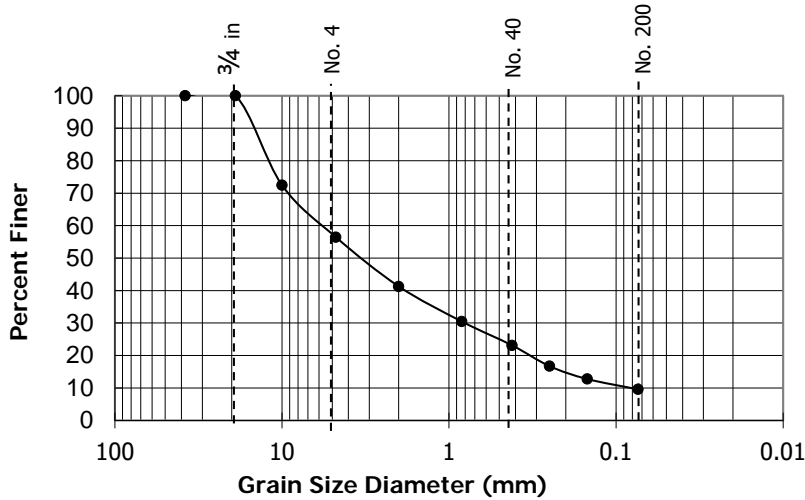

SIEVE	% Passing
1 1/2 "	100
3/4"	100
3/8"	72
#4	56
#10	41
#20	30
#40	23
#60	17
#100	13
#200	10
Pan	--

USCS Group Symbol	SW-SC
USCS Group Name	WELL GRADED SAND with clay and gravel
Cu	70.5
Cc	1.3
LL	30
PI	12
Gravel	43.5
Sand	46.9
Fines	9.6
AASHTO Classification	A-2-6
Color	Brown

Test Method: ASTM D 422

Soil Classification by ASTM D2487 and AASHTO M 145

Reviewed by:

Lindsay Bantz



LIQUID AND PLASTIC LIMIT - ASTM D4318			
Project No.	14189	Project Name	Columbia Pike Multimodal Street Improvements
Test Boring No.	AB-13	Depth (Feet)	3.0-5.0
Lab Order No.	3754-5	Date	3/22/2016

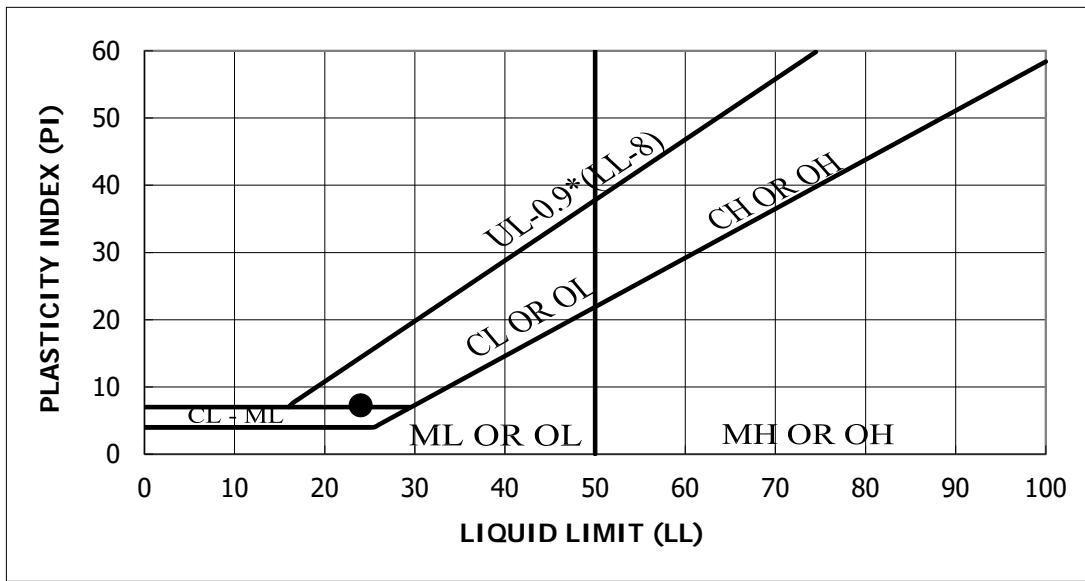

Material Description	LL	PL	PI	% Passing		USCS	w (%)
				#4	#200		
sandy Lean Clay	24	17	7	98.7	64.8	CL	13.7
Color	Dark Brown		AASHTO Classification		A-4		

Test Method: ASTM D 4318
Soil Classification by ASTM D2487 and AASHTO M 145

Reviewed by Lindsay Bantz



GRAIN SIZE ANALYSIS - ASTM D422			
Project No.	14189	Project Name	Columbia Pike Multimodal Street Improvements
Test Boring No.	AB-13	Depth (Feet)	3.0-5.0
Lab Order No.	3754-5	Date	3/22/2016

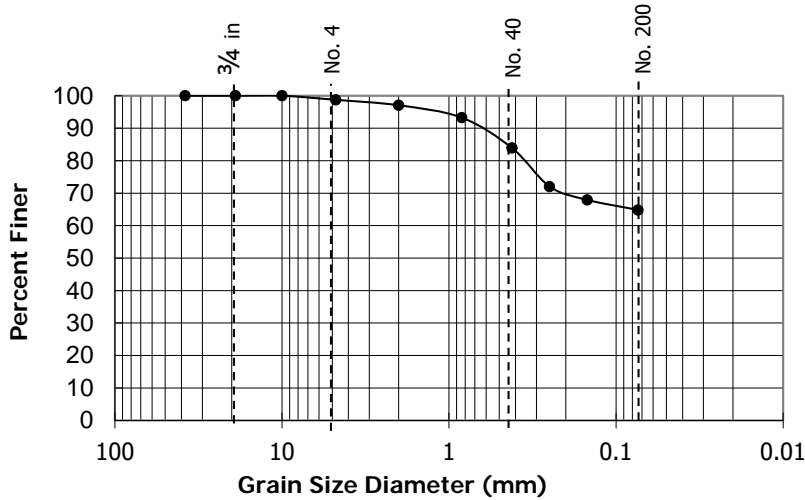

SIEVE	% Passing
1 1/2 "	100
3/4"	100
3/8"	100
#4	99
#10	97
#20	93
#40	84
#60	72
#100	68
#200	65
Pan	--

USCS Group Symbol	CL
USCS Group Name	sandy Lean Clay
Cu	---
Cc	---
LL	24
PI	7
Gravel	1.3
Sand	33.9
Fines	64.8
AASHTO Classification	A-4
Color	Dark Brown

Test Method: ASTM D 422

Soil Classification by ASTM D2487 and AASHTO M 145

Reviewed by:

Lindsay Bantz



LIQUID AND PLASTIC LIMIT - ASTM D4318			
Project No.	14189	Project Name	Columbia Pike Multimodal St. Improvements
Test Boring No.	AB-15	Depth (Feet)	0.0'-5.0'
Lab Order No.	3754-7	Date	3/17/2016

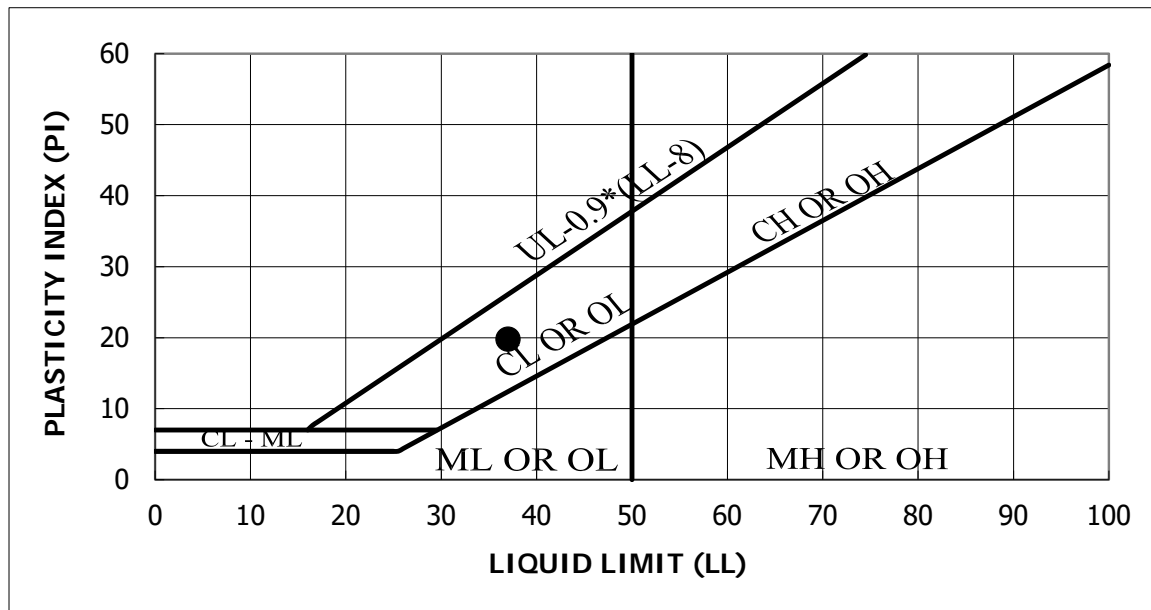

Material Description	LL	PL	PI	% Passing		USCS	w (%)
				#4	#200		
CLAYEY SAND	37	17	20	88.3	30.8	SC	10.1
Color	Brown		AASHTO Classification			A-2-6	

Test Method: ASTM D 4318
Soil Classification by ASTM D2487 and AASHTO M 145

Reviewed by Lindsay Bantz



GRAIN SIZE ANALYSIS - ASTM D422			
Project No.	14189	Project Name	Columbia Pike Multimodal St. Improvements
Test Boring No.	AB-15	Depth (Feet)	0.0'-5.0'
Lab Order No.	3754-7	Date	3/17/2016

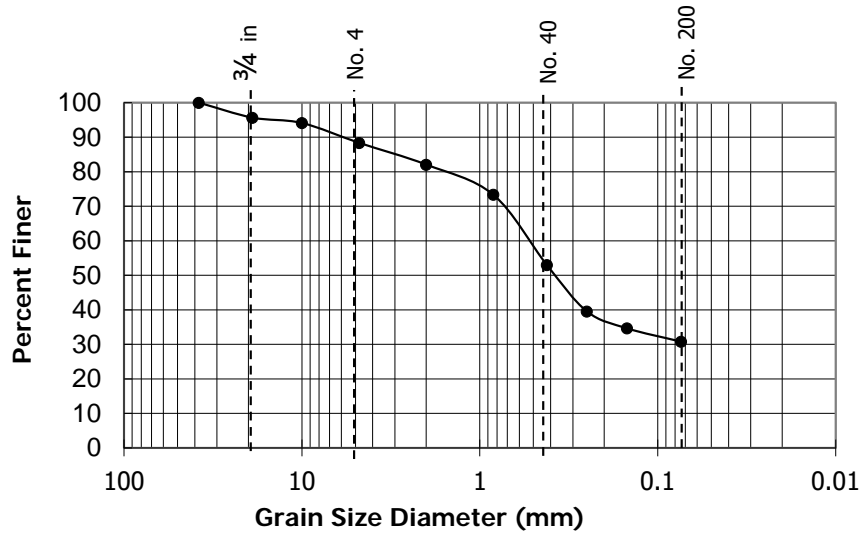

SIEVE	% Passing
1 1/2 "	100
3/4"	96
3/8"	94
#4	88
#10	82
#20	73
#40	53
#60	40
#100	35
#200	31
Pan	--

USCS Group Symbol	SC
USCS Group Name	CLAYEY SAND
Cu	---
Cc	---
LL	37
PI	20
Gravel	11.7
Sand	57.6
Fines	30.8
AASHTO Classification	A-2-6
Color	Brown

Test Method: ASTM D 422

Soil Classification by ASTM D2487 and AASHTO M 145

Reviewed by:

Lindsay Bartz



LIQUID AND PLASTIC LIMIT - ASTM D4318			
Project No.	14189	Project Name	Columbia Pike Multimodal Street Improvements
Test Boring No.	AB-16	Depth (Feet)	7.3-9.3
Lab Order No.	3754-10	Date	3/22/2016

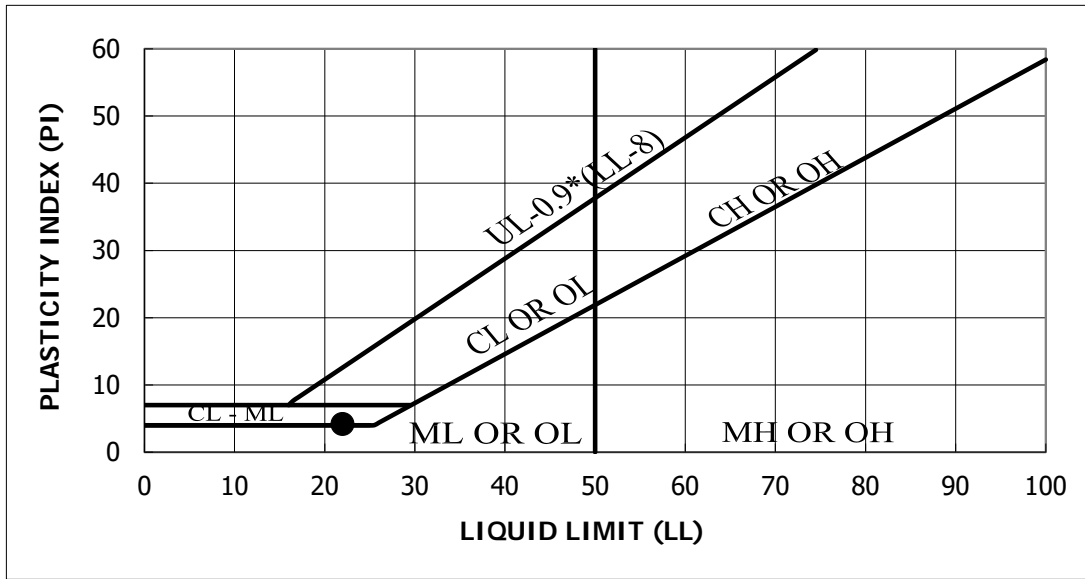

Material Description	LL	PL	PI	% Passing		USCS	w (%)
				#4	#200		
sandy silty Clay	22	18	4	91.4	58.7	CL-ML	18.5
Color	Gray		AASHTO Classification		A-4		

Test Method: ASTM D 4318
 Soil Classification by ASTM D2487 and AASHTO M 145

Reviewed by Lindsay Bantz



GRAIN SIZE ANALYSIS - ASTM D422			
Project No.	14189	Project Name	Columbia Pike Multimodal Street Improvements
Test Boring No.	AB-16	Depth (Feet)	7.3-9.3
Lab Order No.	3754-10	Date	3/22/2016

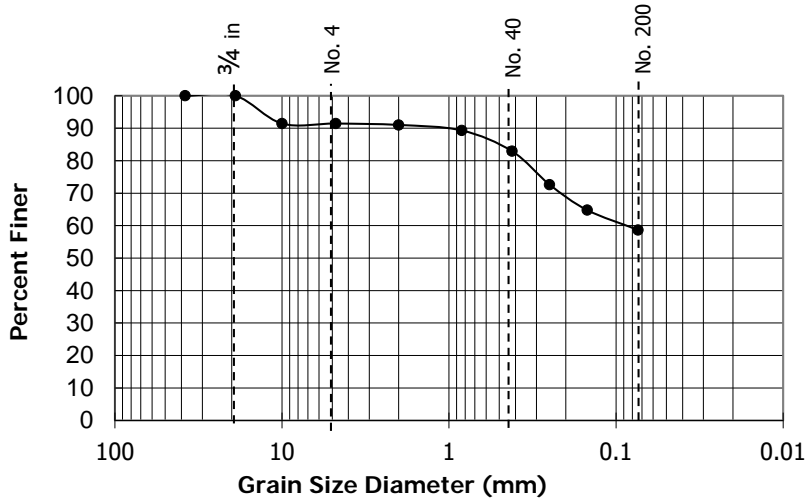

SIEVE	% Passing
1 1/2 "	100
3/4"	100
3/8"	91
#4	91
#10	91
#20	89
#40	83
#60	73
#100	65
#200	59
Pan	--

USCS Group Symbol	CL-ML
USCS Group Name	sandy silty Clay
Cu	---
Cc	---
LL	22
PI	4
Gravel	8.6
Sand	32.8
Fines	58.7
AASHTO Classification	A-4
Color	Gray

Test Method: ASTM D 422

Soil Classification by ASTM D2487 and AASHTO M 145

Reviewed by:

Lindsay Bartz

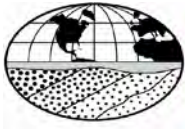

LIQUID AND PLASTIC LIMIT - ASTM D4318			
Project No.	14189	Project Name	Columbia Pike Multimodal St. Improvements
Test Boring No.	CRW-2	Depth (Feet)	0.0'-5.0'
Lab Order No.	3486-13	Date	3/5/2015

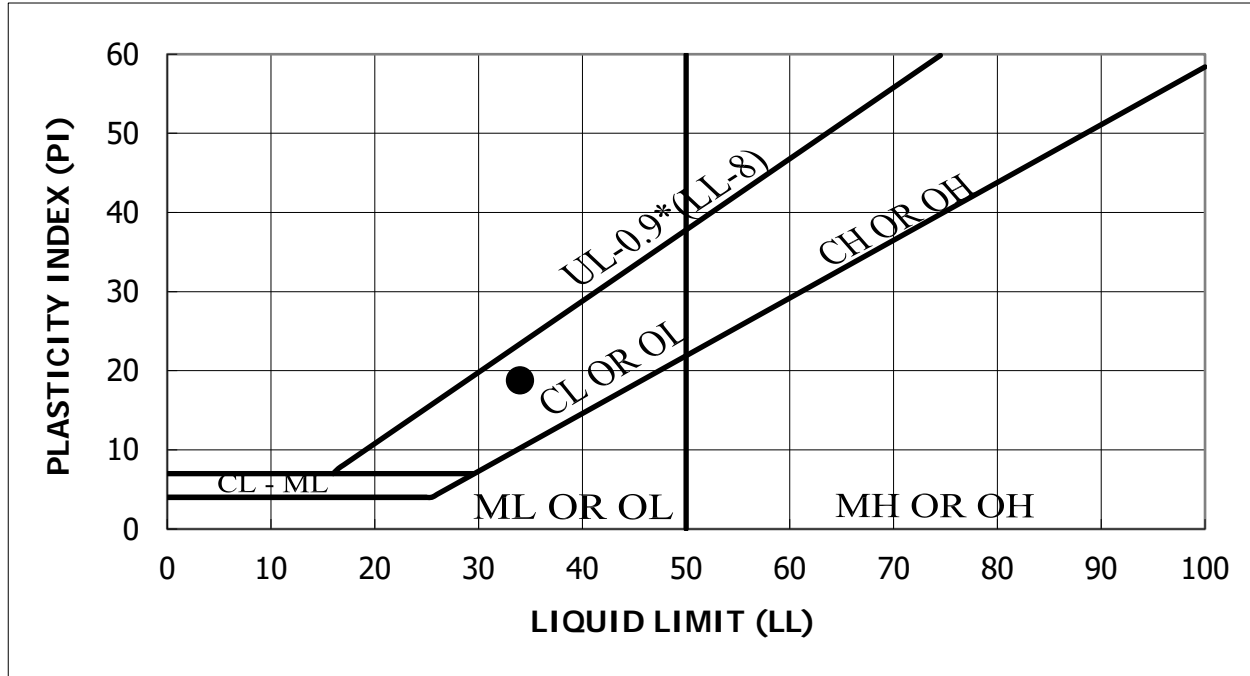

Material Description	LL	PL	PI	% Passing		USCS	w (%)
				#4	#200		
CLAYEY SAND	34	15	19	90.1	44.9	SC	14.2
Color	Brown		AASHTO Classification		A-6		

Test Method: ASTM D 4318

Soil Classification by ASTM D2487 and AASHTO M 145

Tested by _____

Reviewed by Chic M. [Signature]



GRAIN SIZE ANALYSIS - ASTM D422			
Project No.	14189	Project Name	Columbia Pike Multimodal St. Improvements
Test Boring No.	CRW-2	Depth (Feet)	0.0'-5.0'
Lab Order No.	3486-13	Date	3/5/2015

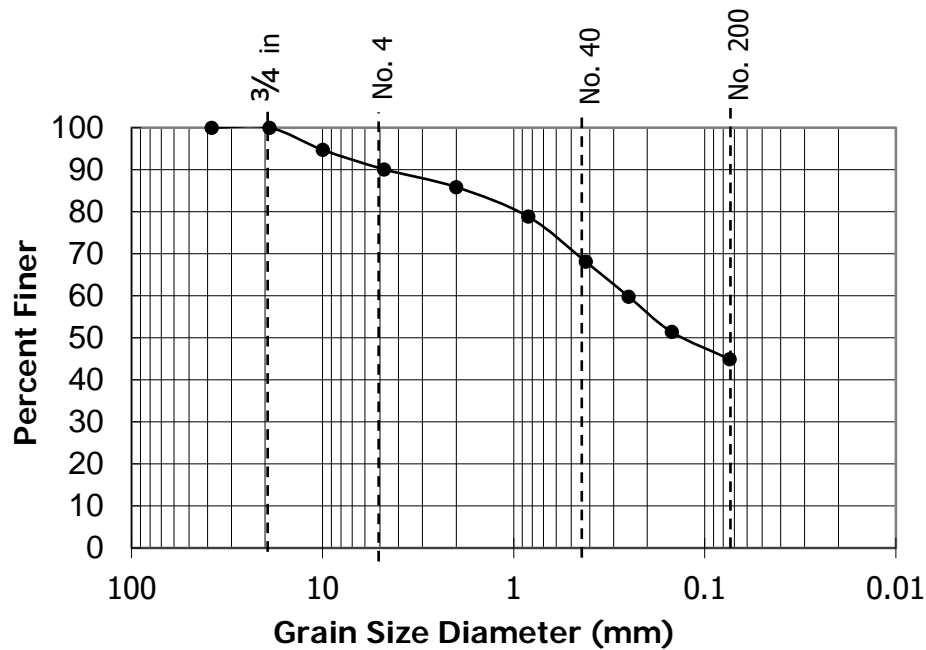

SIEVE	% Passing
1 1/2 "	100
3/4"	100
3/8"	95
#4	90
#10	86
#20	79
#40	68
#60	60
#100	51
#200	45
Pan	--

USCS Group Symbol	SC
USCS Group Name	CLAYEY SAND
Cu	---
Cc	---
LL	34
PI	19
Gravel	9.9
Sand	45.2
Fines	44.9
AASHTO Classification	A-6
Color	Brown

Test Method: ASTM D 422

Soil Classification by ASTM D2487 and AASHTO M 145

Tested by: _____

Reviewed by:

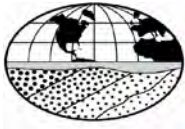

LIQUID AND PLASTIC LIMIT - ASTM D4318			
Project No.	14189	Project Name	Columbia Pike Multimodal St. Improvements
Test Boring No.	CB-3	Depth (Feet)	1.0'-2.5'
Lab Order No.	3486-1	Date	3/13/2015

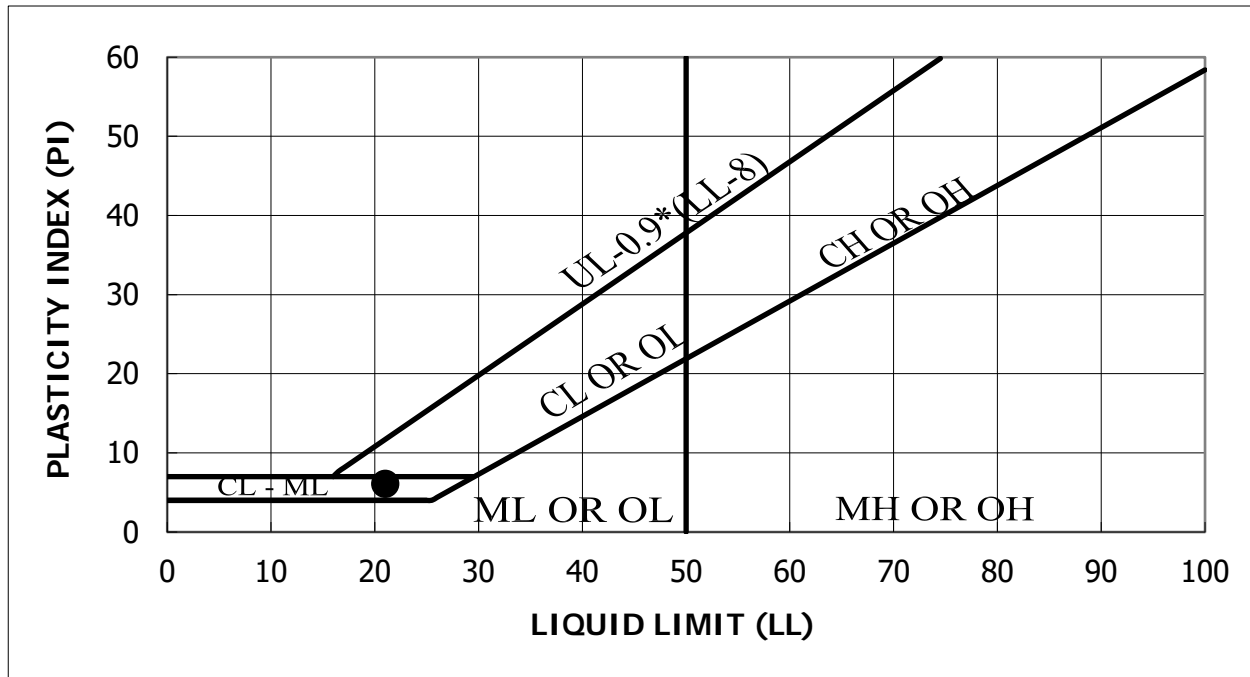

Material Description	LL	PL	PI	% Passing		USCS	w (%)
				#4	#200		
sandy silty Clay with gravel	21	15	6	83.4	64.0	CL-ML	14.4
Color	Dark Gray		AASHTO Classification		A-4		

Test Method: ASTM D 4318

Soil Classification by ASTM D2487 and AASHTO M 145

Tested by _____

Reviewed by Chil. M. [Signature]



GRAIN SIZE ANALYSIS - ASTM D422			
Project No.	14189	Project Name	Columbia Pike Multimodal St. Improvements
Test Boring No.	CB-3	Depth (Feet)	1.0'-2.5'
Lab Order No.	3486-1	Date	3/13/2015

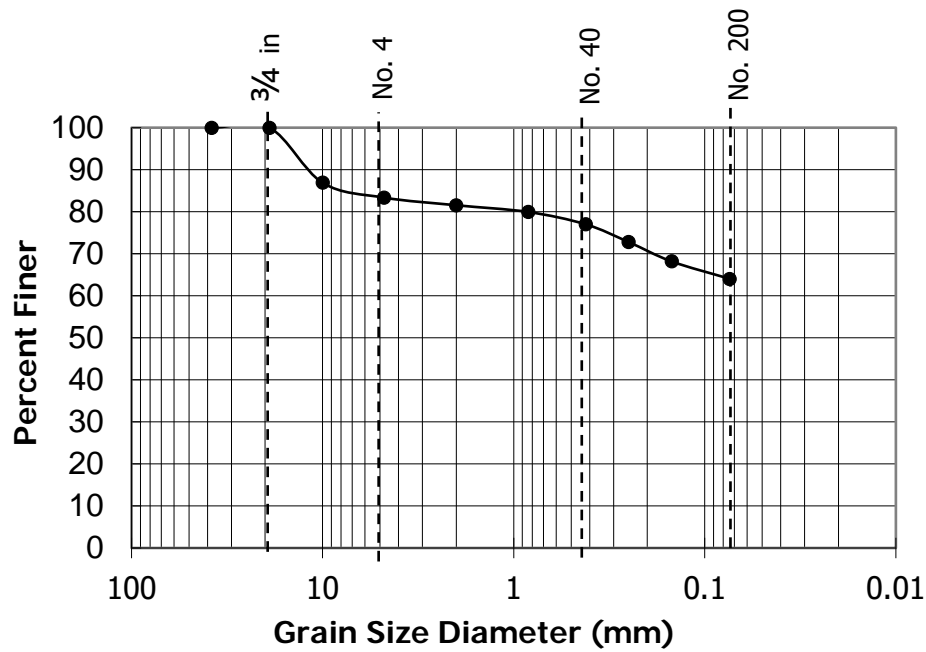

SIEVE	% Passing
1 1/2 "	100
3/4"	100
3/8"	87
#4	83
#10	82
#20	80
#40	77
#60	73
#100	68
#200	64
Pan	--

USCS Group Symbol	CL-ML
USCS Group Name	sandy silty Clay with gravel
Cu	---
Cc	---
LL	21
PI	6
Gravel	16.6
Sand	19.3
Fines	64.0
AASHTO Classification	A-4
Color	Dark Gray

Test Method: ASTM D 422

Soil Classification by ASTM D2487 and AASHTO M 145

Tested by: _____

Reviewed by:

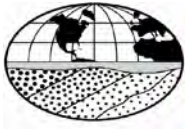

LIQUID AND PLASTIC LIMIT - ASTM D4318			
Project No.	14189	Project Name	Columbia Pike Multimodal St. Improvements
Test Boring No.	CB-5	Depth (Feet)	0.0'-5.0'
Lab Order No.	3486-12	Date	3/5/2015

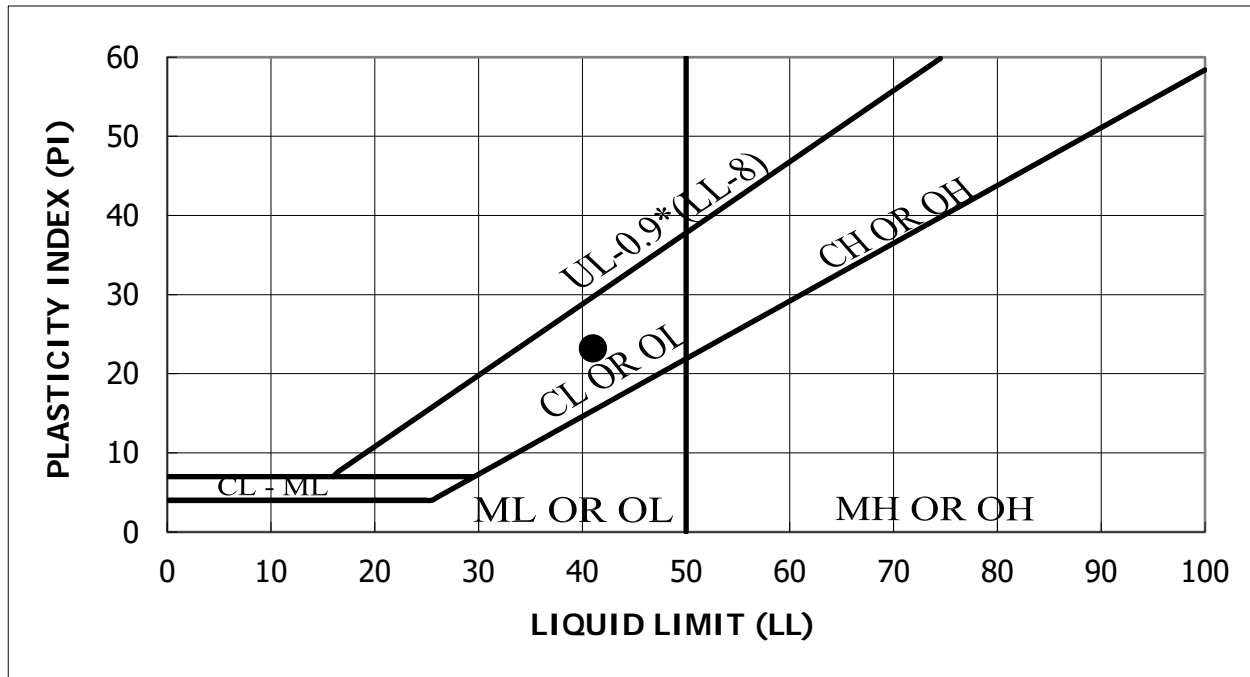

Material Description	LL	PL	PI	% Passing		USCS	w (%)
				#4	#200		
sandy Lean Clay	41	18	23	85.7	59.1	CL	9.7
Color	Light Grayish Brown		AASHTO Classification		A-7-6		

Test Method: ASTM D 4318

Soil Classification by ASTM D2487 and AASHTO M 145

Tested by _____

Reviewed by Chic. M. [Signature]



GRAIN SIZE ANALYSIS - ASTM D422			
Project No.	14189	Project Name	Columbia Pike Multimodal St. Improvements
Test Boring No.	CB-5	Depth (Feet)	0.0'-5.0'
Lab Order No.	3486-12	Date	3/5/2015

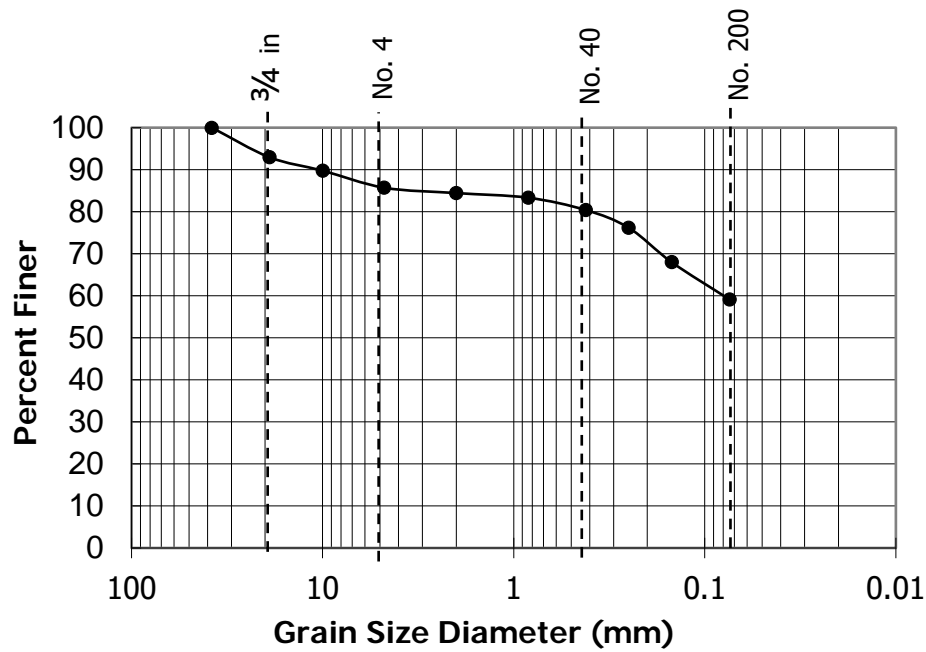

SIEVE	% Passing
1 1/2 "	100
3/4"	93
3/8"	90
#4	86
#10	84
#20	83
#40	80
#60	76
#100	68
#200	59
Pan	--

USCS Group Symbol	CL
USCS Group Name	sandy Lean Clay
Cu	---
Cc	---
LL	41
PI	23
Gravel	14.3
Sand	26.6
Fines	59.1
AASHTO Classification	A-7-6
Color	Light Grayish Brown

Test Method: ASTM D 422

Soil Classification by ASTM D2487 and AASHTO M 145

Tested by: _____

Reviewed by:

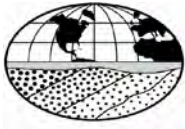

LIQUID AND PLASTIC LIMIT - ASTM D4318			
Project No.	14189	Project Name	Columbia Pike Street Improvements
Test Boring No.	CB-8	Depth (Feet)	0.0'-5.0'
Lab Order No.	3483-2	Date	3/5/2014

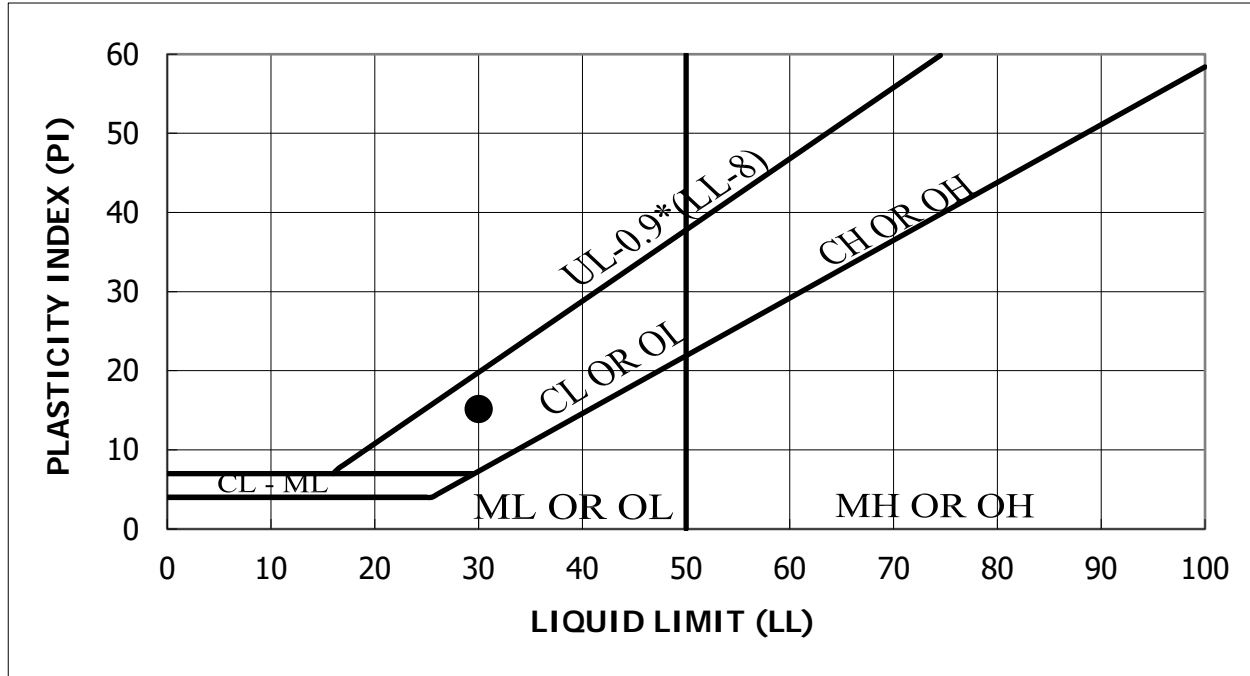

Material Description	LL	PL	PI	% Passing		USCS	w (%)
				#4	#200		
CLAYEY SAND	30	15	15	94.7	42.1	SC	16.6
Color	Dark Brownish Gray		AASHTO Classification		A-6		

Test Method: ASTM D 4318

Soil Classification by ASTM D2487 and AASHTO M 145

Tested by _____

Reviewed by Chic. M. [Signature]



GRAIN SIZE ANALYSIS - ASTM D422			
Project No.	14189	Project Name	Columbia Pike Street Improvements
Test Boring No.	CB-8	Depth (Feet)	0.0'-5.0'
Lab Order No.	3483-2	Date	3/5/2014

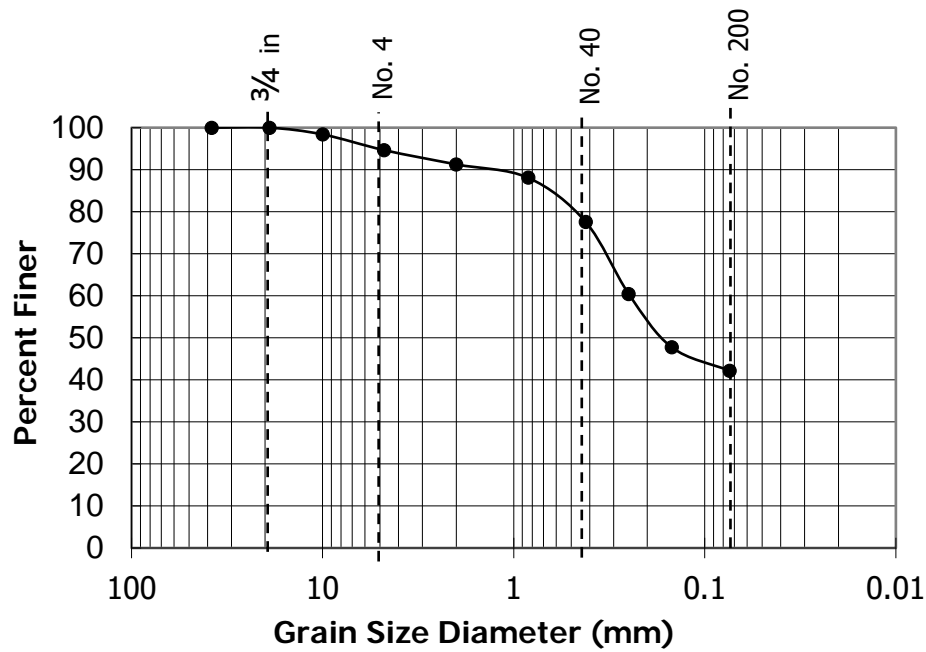

SIEVE	% Passing
1 1/2 "	100
3/4"	100
3/8"	98
#4	95
#10	91
#20	88
#40	78
#60	60
#100	48
#200	42
Pan	--

USCS Group Symbol	SC
USCS Group Name	CLAYEY SAND
Cu	---
Cc	---
LL	30
PI	15
Gravel	5.3
Sand	52.5
Fines	42.1
AASHTO Classification	A-6
Color	Dark Brownish Gray

Test Method: ASTM D 422

Soil Classification by ASTM D2487 and AASHTO M 145

Tested by: _____

Reviewed by:

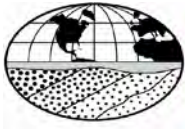

LIQUID AND PLASTIC LIMIT - ASTM D4318			
Project No.	14189	Project Name	Columbia Pike Street Improvements
Test Boring No.	DB-2	Depth (Feet)	0.0'-5.0'
Lab Order No.	3483-1	Date	3/5/2014

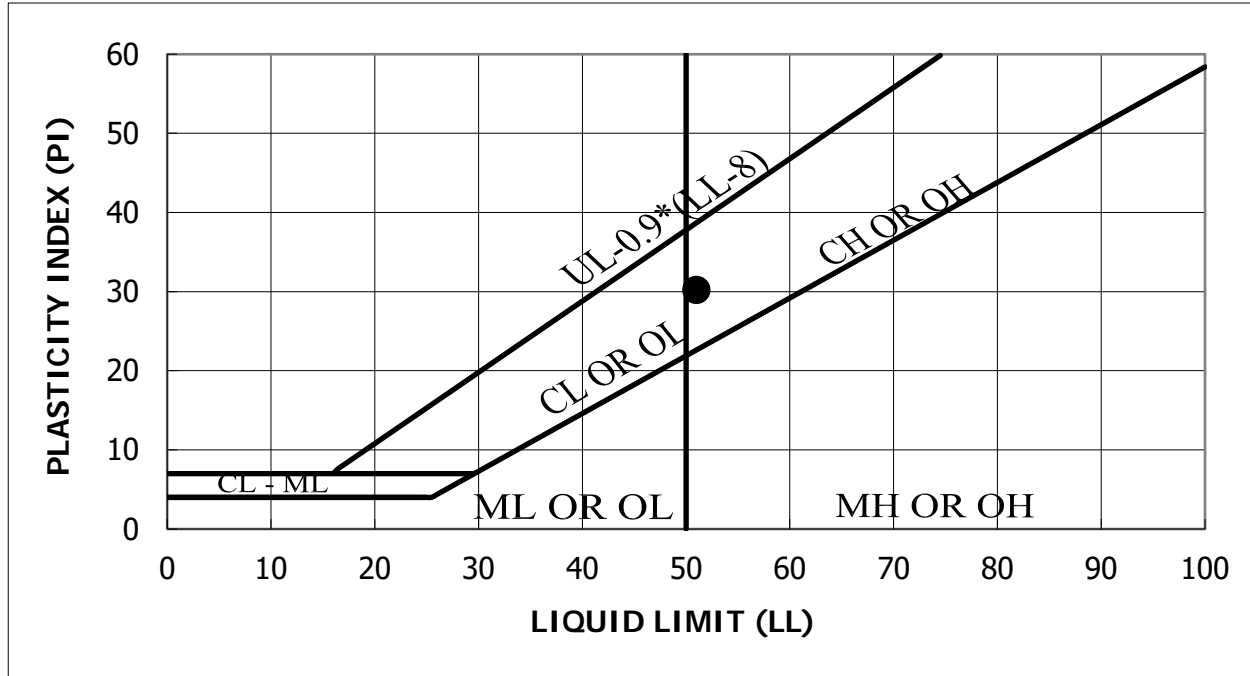

Material Description	LL	PL	PI	% Passing		USCS	w (%)
				#4	#200		
sandy Fat Clay with gravel	51	21	30	81.8	61.2	CH	17.5
Color	Orange Brown		AASHTO Classification		A-7-6		

Test Method: ASTM D 4318

Soil Classification by ASTM D2487 and AASHTO M 145

Tested by _____

Reviewed by Chil M. [Signature]



GRAIN SIZE ANALYSIS - ASTM D422			
Project No.	14189	Project Name	Columbia Pike Street Improvements
Test Boring No.	DB-2	Depth (Feet)	0.0'-5.0'
Lab Order No.	3483-1	Date	3/5/2014

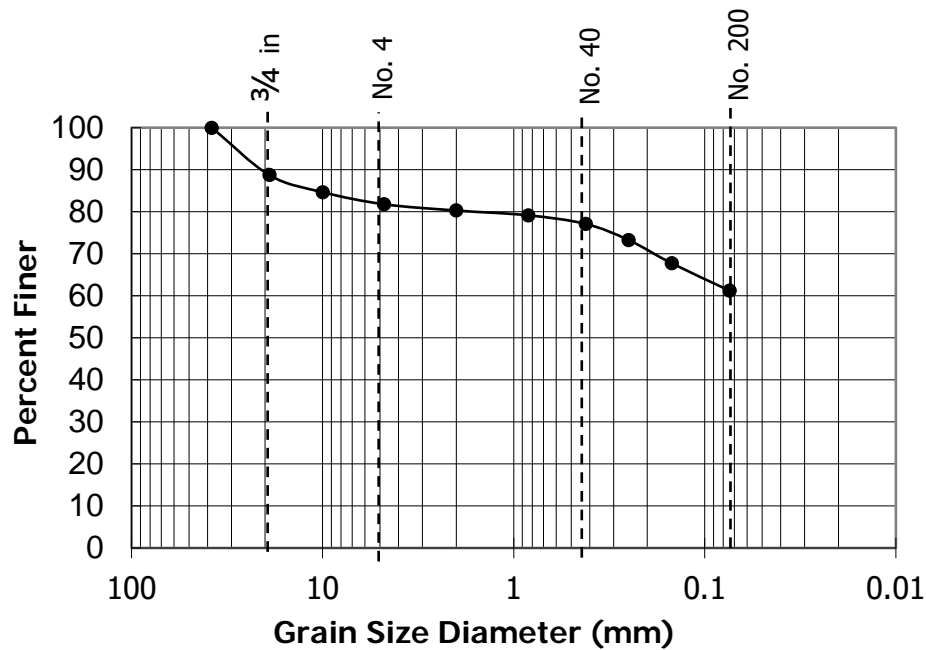

SIEVE	% Passing
1 1/2 "	100
3/4"	89
3/8"	85
#4	82
#10	80
#20	79
#40	77
#60	73
#100	68
#200	61
Pan	--

USCS Group Symbol	CH
USCS Group Name	sandy Fat Clay with gravel
Cu	---
Cc	---
LL	51
PI	30
Gravel	18.2
Sand	20.6
Fines	61.2
AASHTO Classification	A-7-6
Color	Orange Brown

Test Method: ASTM D 422

Soil Classification by ASTM D2487 and AASHTO M 145

Tested by: _____

Reviewed by:

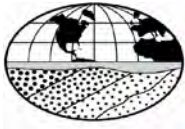

LIQUID AND PLASTIC LIMIT - ASTM D4318			
Project No.	14189	Project Name	Columbia Pike Multimodal
Test Boring No.	DB-4	Depth (Feet)	5.0'-6.5'
Lab Order No.	3484-3	Date	3/3/2015

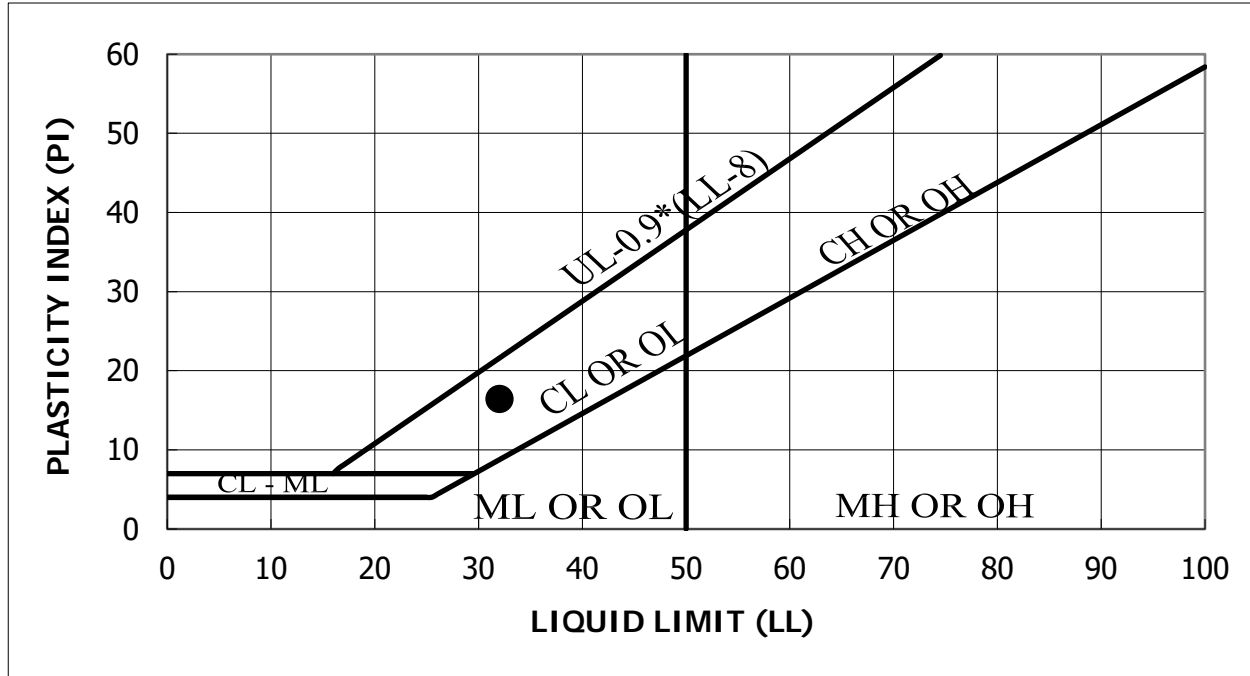

Material Description	LL	PL	PI	% Passing		USCS	w (%)
				#4	#200		
CLAYEY GRAVEL with sand	32	16	16	56.7	22.2	GC	13.4
Color	Dark Gray		AASHTO Classification		A-2-6		

Test Method: ASTM D 4318

Soil Classification by ASTM D2487 and AASHTO M 145

Tested by _____

Reviewed by Shawn Harris



GRAIN SIZE ANALYSIS - ASTM D422			
Project No.	14189	Project Name	Columbia Pike Multimodal
Test Boring No.	DB-4	Depth (Feet)	5.0'-6.5'
Lab Order No.	3484-3	Date	3/3/2015

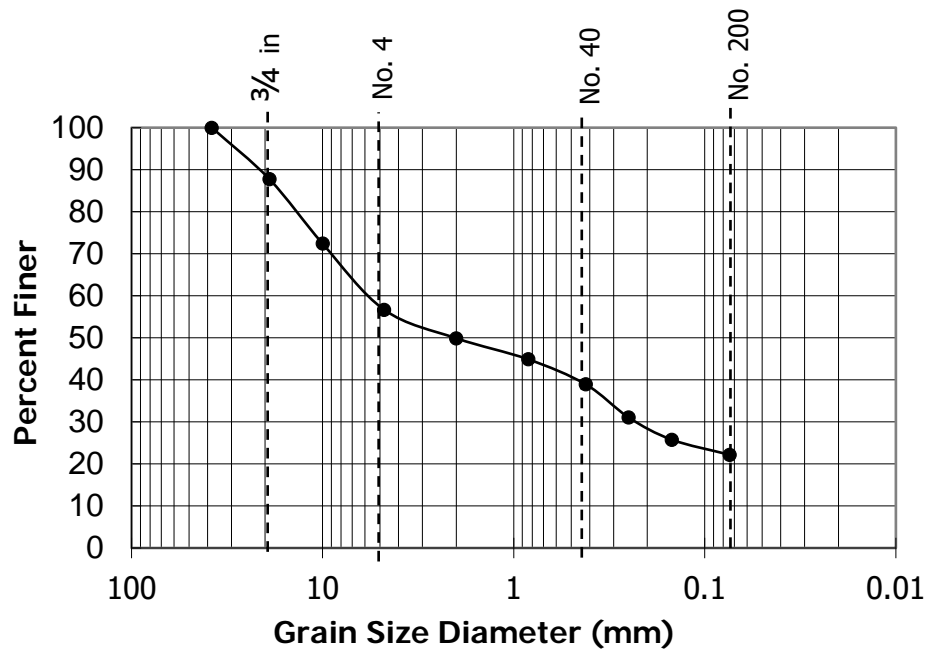

SIEVE	% Passing
1 1/2 "	100
3/4"	88
3/8"	72
#4	57
#10	50
#20	45
#40	39
#60	31
#100	26
#200	22
Pan	--

USCS Group Symbol	GC
USCS Group Name	CLAYEY GRAVEL with sand
Cu	---
Cc	---
LL	32
PI	16
Gravel	43.3
Sand	34.5
Fines	22.2
AASHTO Classification	A-2-6
Color	Dark Gray

Test Method: ASTM D 422

Soil Classification by ASTM D2487 and AASHTO M 145

Tested by: _____

Reviewed by: Shu Harris

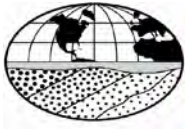

LIQUID AND PLASTIC LIMIT - ASTM D4318			
Project No.	14189	Project Name	Columbia Pike Multimodal
Test Boring No.	DB-6	Depth (Feet)	0.0'-5.0'
Lab Order No.	3481-2	Date	3/3/2015

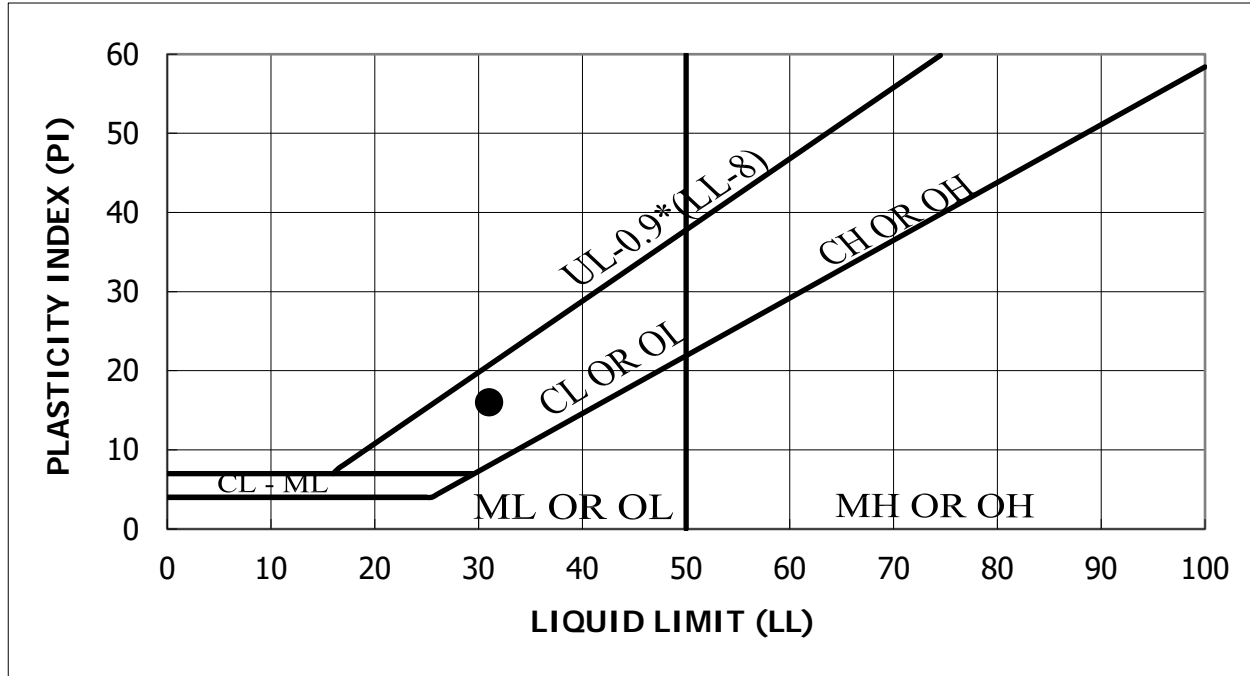

Material Description	LL	PL	PI	% Passing		USCS	w (%)
				#4	#200		
CLAYEY SAND with gravel	31	15	16	84.9	32.1	SC	11.0
Color	Dark Gray		AASHTO Classification		A-2-6		

Test Method: ASTM D 4318

Soil Classification by ASTM D2487 and AASHTO M 145

Tested by _____

Reviewed by Shawn Harris



GRAIN SIZE ANALYSIS - ASTM D422			
Project No.	14189	Project Name	Columbia Pike Multimodal
Test Boring No.	DB-6	Depth (Feet)	0.0'-5.0'
Lab Order No.	3481-2	Date	3/3/2015

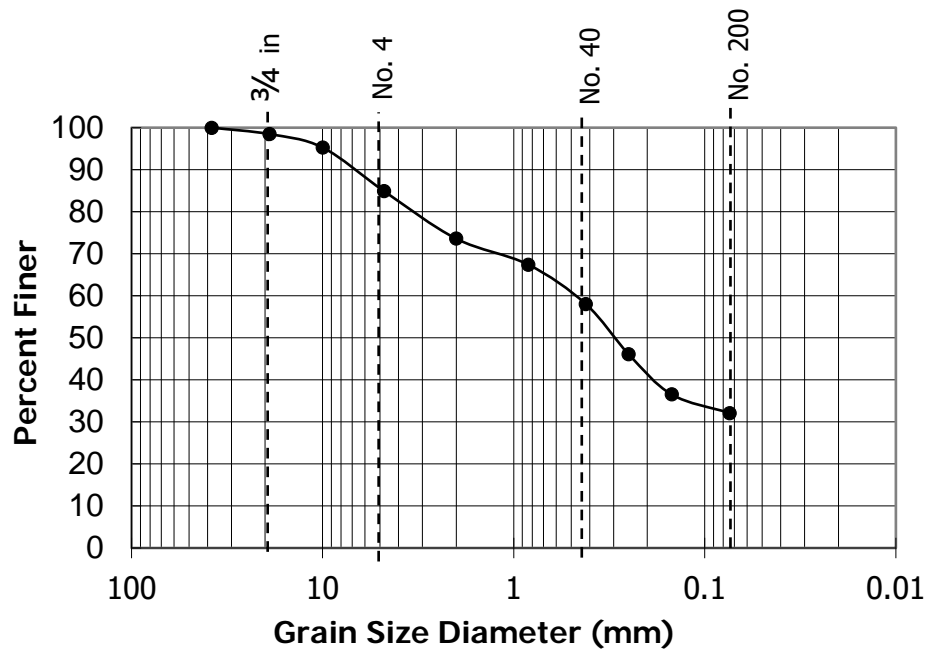

SIEVE	% Passing
1 1/2 "	100
3/4"	98
3/8"	95
#4	85
#10	74
#20	67
#40	58
#60	46
#100	37
#200	32
Pan	--

USCS Group Symbol	SC
USCS Group Name	CLAYEY SAND with gravel
Cu	---
Cc	---
LL	31
PI	16
Gravel	15.1
Sand	52.8
Fines	32.1
AASHTO Classification	A-2-6
Color	Dark Gray

Test Method: ASTM D 422

Soil Classification by ASTM D2487 and AASHTO M 145

Tested by: _____

Reviewed by: _____

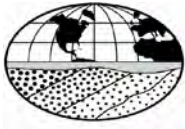

LIQUID AND PLASTIC LIMIT - ASTM D4318			
Project No.	14189	Project Name	Columbia Pike Multimodal
Test Boring No.	DB-10	Depth (Feet)	0.0'-5.0'
Lab Order No.	3481-1	Date	3/3/2015

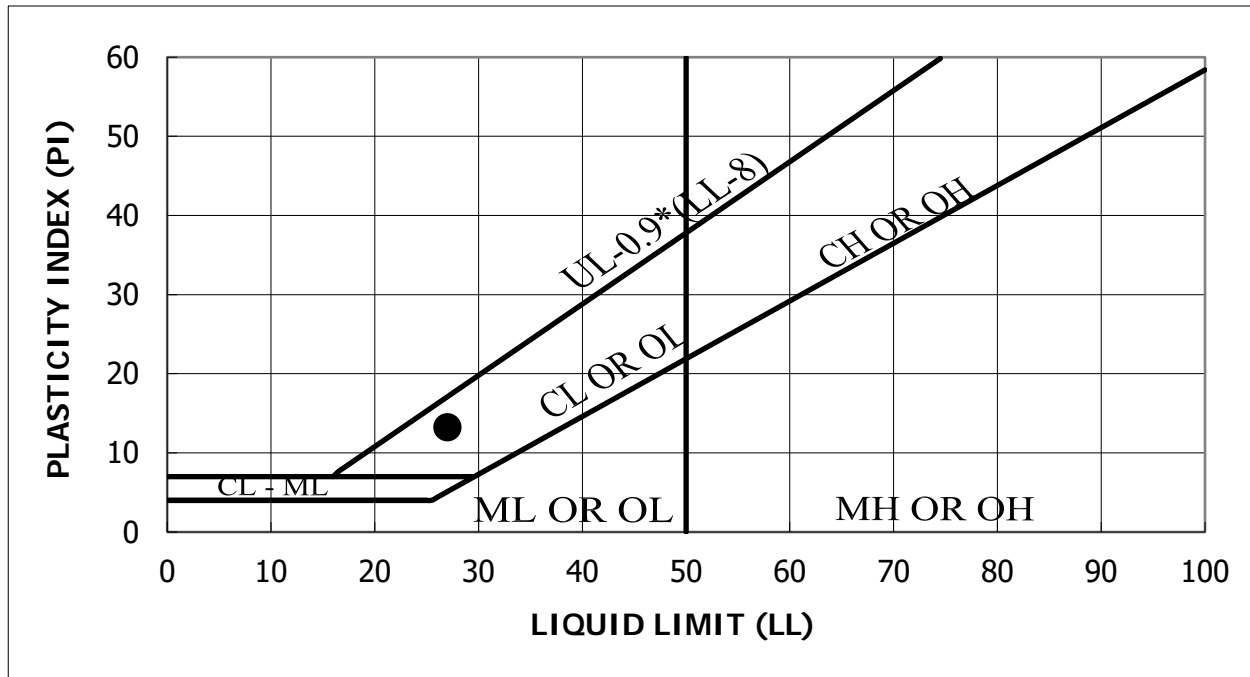

Material Description	LL	PL	PI	% Passing		USCS	w (%)
				#4	#200		
CLAYEY SAND	27	14	13	97.9	44.4	SC	16.1
Color	Brownish Gray		AASHTO Classification			A-6	

Test Method: ASTM D 4318

Soil Classification by ASTM D2487 and AASHTO M 145

Tested by _____

Reviewed by John Harris



GRAIN SIZE ANALYSIS - ASTM D422			
Project No.	14189	Project Name	Columbia Pike Multimodal
Test Boring No.	DB-10	Depth (Feet)	0.0'-5.0'
Lab Order No.	3481-1	Date	3/3/2015

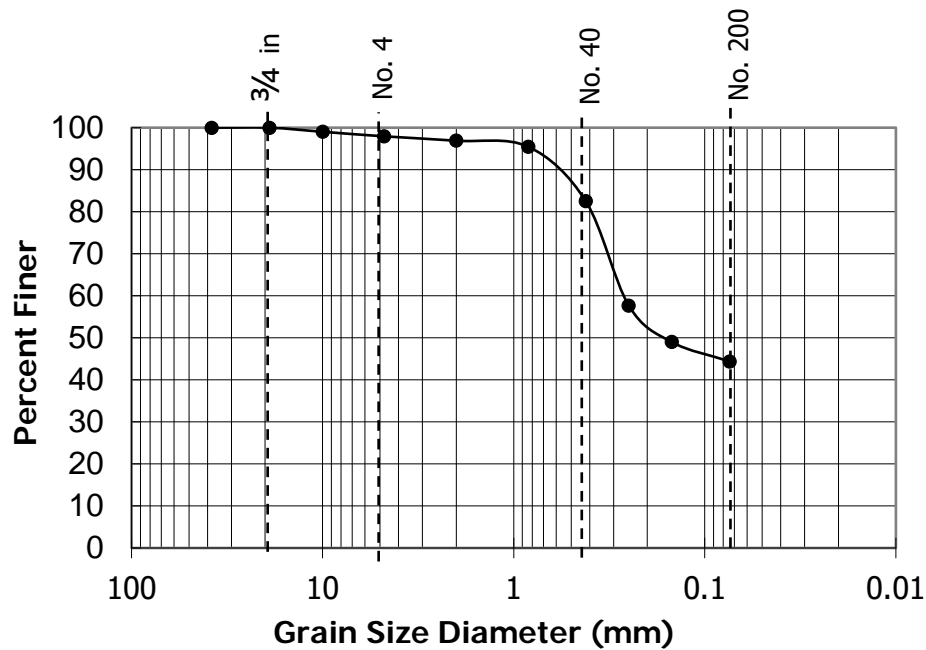

SIEVE	% Passing
1 1/2 "	100
3/4"	100
3/8"	99
#4	98
#10	97
#20	95
#40	83
#60	58
#100	49
#200	44
Pan	--

USCS Group Symbol	SC
USCS Group Name	CLAYEY SAND
Cu	---
Cc	---
LL	27
PI	13
Gravel	2.1
Sand	53.6
Fines	44.4
AASHTO Classification	A-6
Color	Brownish Gray

Test Method: ASTM D 422

Soil Classification by ASTM D2487 and AASHTO M 145

Tested by: _____

Reviewed by: _____

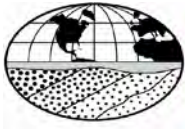

LIQUID AND PLASTIC LIMIT - ASTM D4318			
Project No.	14189	Project Name	Columbia Pike Multimodal St. Improvements
Test Boring No.	FRW-6	Depth (Feet)	5.0'-6.5'
Lab Order No.	3480-8	Date	3/6/2015

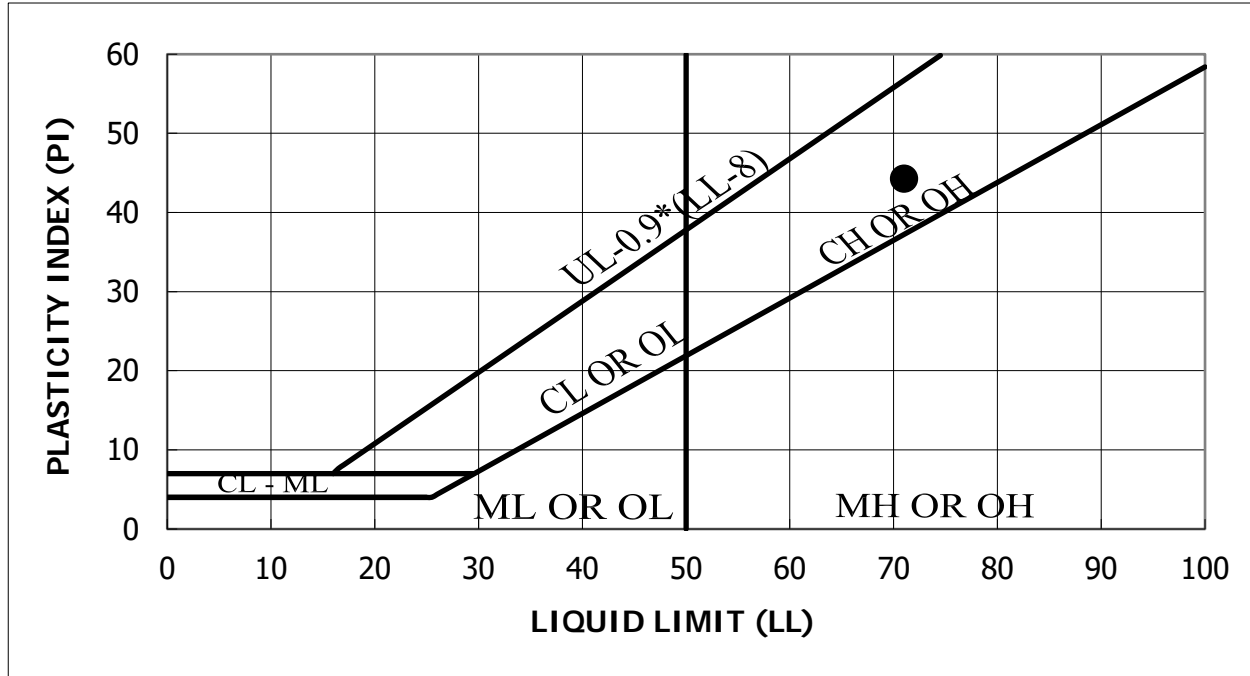

Material Description	LL	PL	PI	% Passing		USCS	w (%)
				#4	#200		
Fat Clay	71	27	44	100.0	93.6	CH	37.2
Color	Gray		AASHTO Classification		A-7-6		

Test Method: ASTM D 4318

Soil Classification by ASTM D2487 and AASHTO M 145

Tested by _____

Reviewed by Chic L. Myler

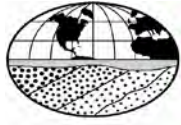

GRAIN SIZE ANALYSIS - ASTM D422			
Project No.	14189	Project Name	Columbia Pike Multimodal St. Improvements
Test Boring No.	FRW-6	Depth (Feet)	5.0'-6.5'
Lab Order No.	3480-8	Date	3/6/2015

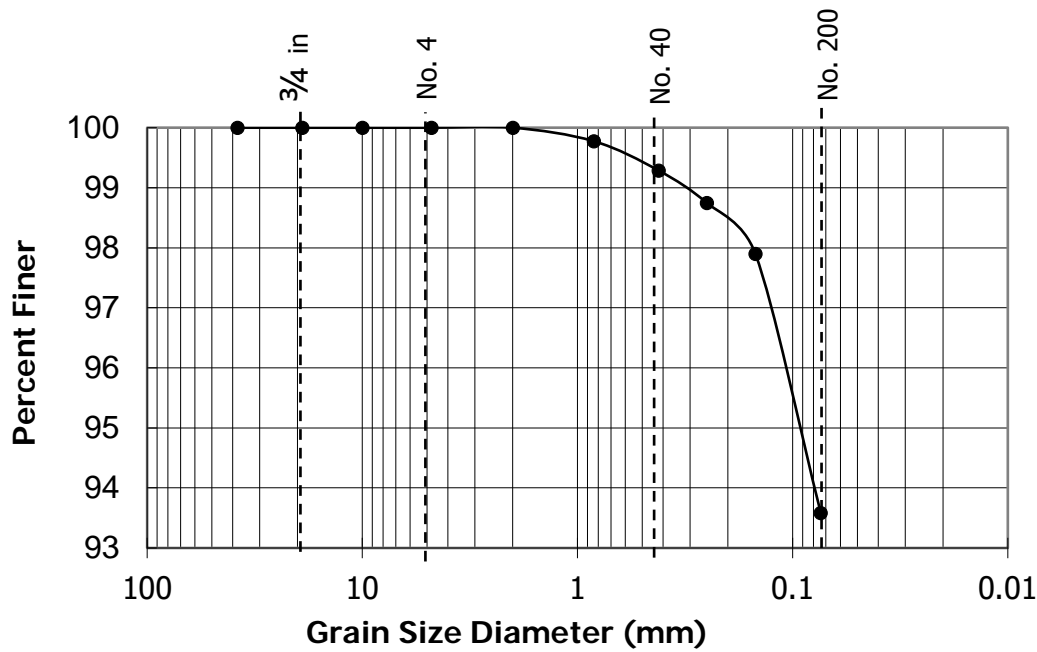

SIEVE	% Passing
1 1/2 "	100
3/4"	100
3/8"	100
#4	100
#10	100
#20	100
#40	99
#60	99
#100	98
#200	94
Pan	--

USCS Group Symbol	CH
USCS Group Name	Fat Clay
Cu	---
Cc	---
LL	71
PI	44
Gravel	0.0
Sand	6.4
Fines	93.6
AASHTO Classification	A-7-6
Color	Gray

Test Method: ASTM D 422

Soil Classification by ASTM D2487 and AASHTO M 145

Tested by: _____

Reviewed by:

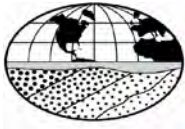

LIQUID AND PLASTIC LIMIT - ASTM D4318			
Project No.	14189	Project Name	Columbia Pike Multimodal St. Improvements
Test Boring No.	FB-2	Depth (Feet)	0.0'-5.0'
Lab Order No.	3480-14	Date	3/6/2015

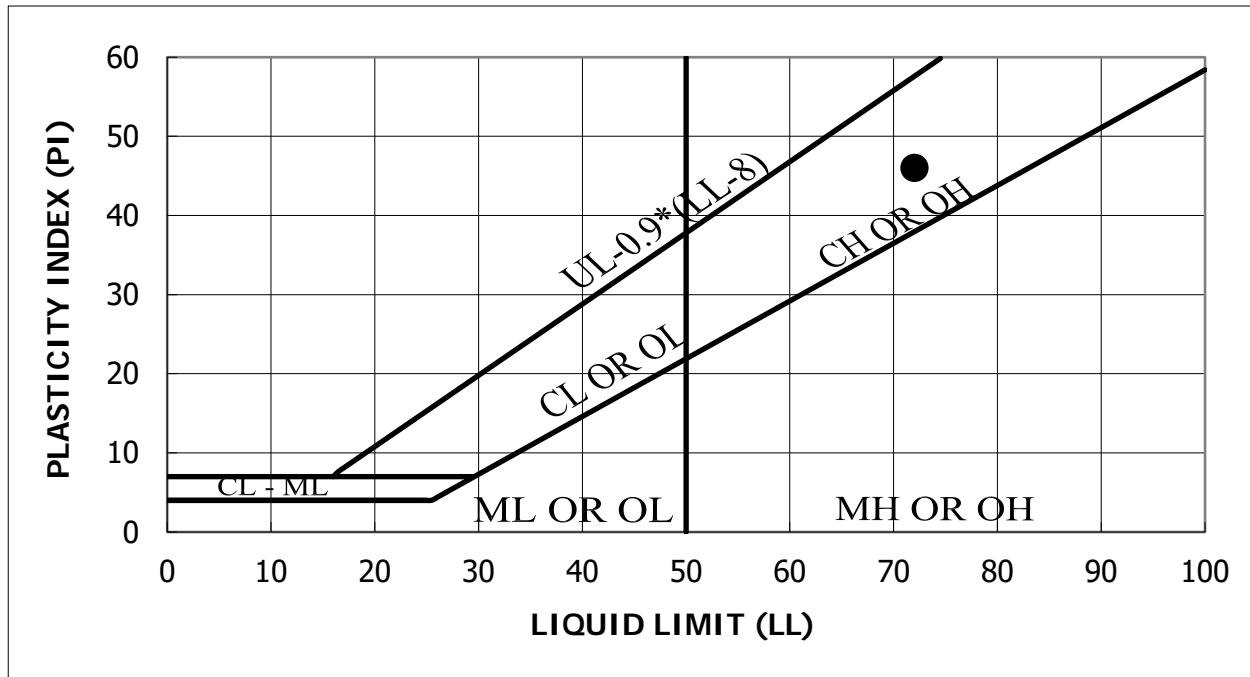

Material Description	LL	PL	PI	% Passing		USCS	w (%)
				#4	#200		
CLAYEY SAND with gravel	72	26	46	83.6	26.8	SC	6.2
Color	Dark Gray		AASHTO Classification		A-2-7		

Test Method: ASTM D 4318

Soil Classification by ASTM D2487 and AASHTO M 145

Tested by _____

Reviewed by Chic. M. [Signature]

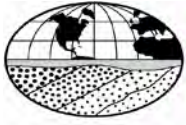

GRAIN SIZE ANALYSIS - ASTM D422			
Project No.	14189	Project Name	Columbia Pike Multimodal St. Improvements
Test Boring No.	FB-2	Depth (Feet)	0.0'-5.0'
Lab Order No.	3480-14	Date	3/6/2015

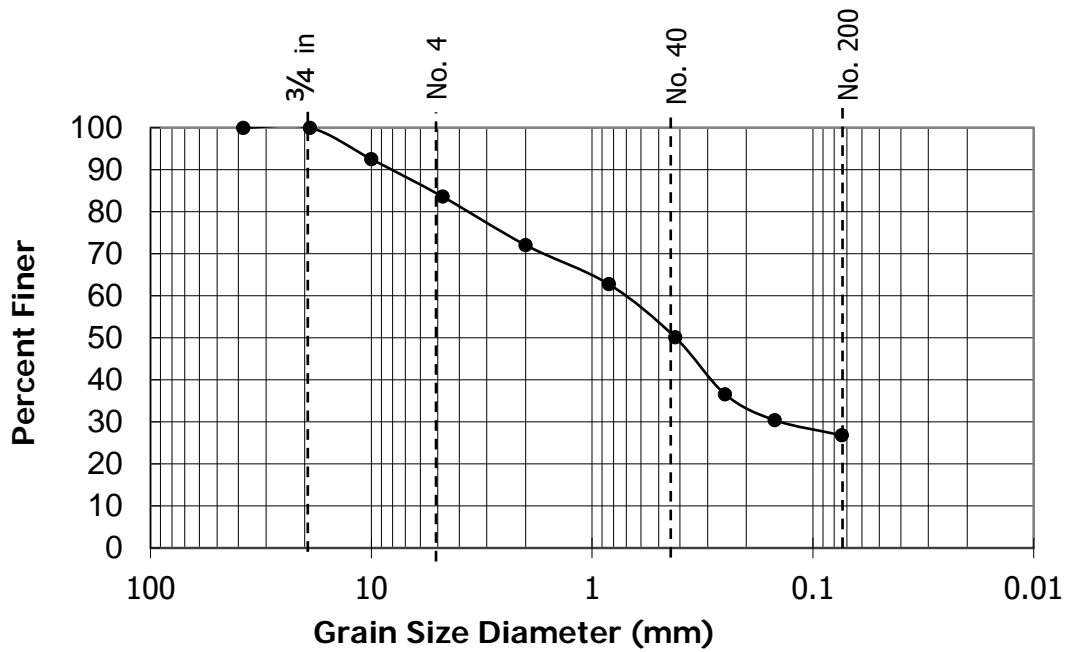

SIEVE	% Passing
1 1/2 "	100
3/4"	100
3/8"	93
#4	84
#10	72
#20	63
#40	50
#60	37
#100	30
#200	27
Pan	--

USCS Group Symbol	SC
USCS Group Name	CLAYEY SAND with gravel
Cu	---
Cc	---
LL	72
PI	46
Gravel	16.4
Sand	56.8
Fines	26.8
AASHTO Classification	A-2-7
Color	Dark Gray

Test Method: ASTM D 422

Soil Classification by ASTM D2487 and AASHTO M 145

Tested by: _____

Reviewed by:

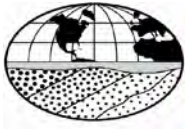

LIQUID AND PLASTIC LIMIT - ASTM D4318			
Project No.	14189	Project Name	Columbia Pike Multimodal St. Improvements
Test Boring No.	FB-9	Depth (Feet)	0.0'-5.0'
Lab Order No.	3480-13	Date	3/6/2015

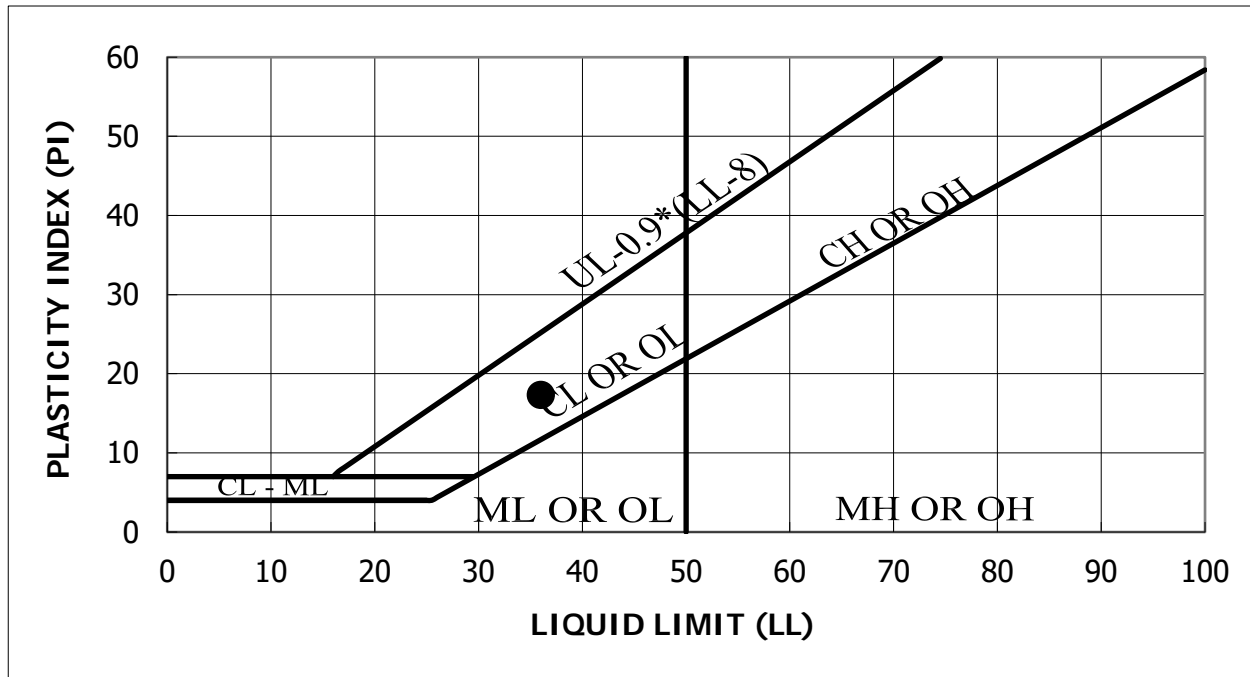

Material Description	LL	PL	PI	% Passing		USCS	w (%)
				#4	#200		
sandy Lean Clay	36	19	17	91.2	51.1	CL	14.5
Color	Brownish Gray		AASHTO Classification		A-6		

Test Method: ASTM D 4318

Soil Classification by ASTM D2487 and AASHTO M 145

Tested by _____

Reviewed by Chil. M. [Signature]



GRAIN SIZE ANALYSIS - ASTM D422			
Project No.	14189	Project Name	Columbia Pike Multimodal St. Improvements
Test Boring No.	FB-9	Depth (Feet)	0.0'-5.0'
Lab Order No.	3480-13	Date	3/6/2015

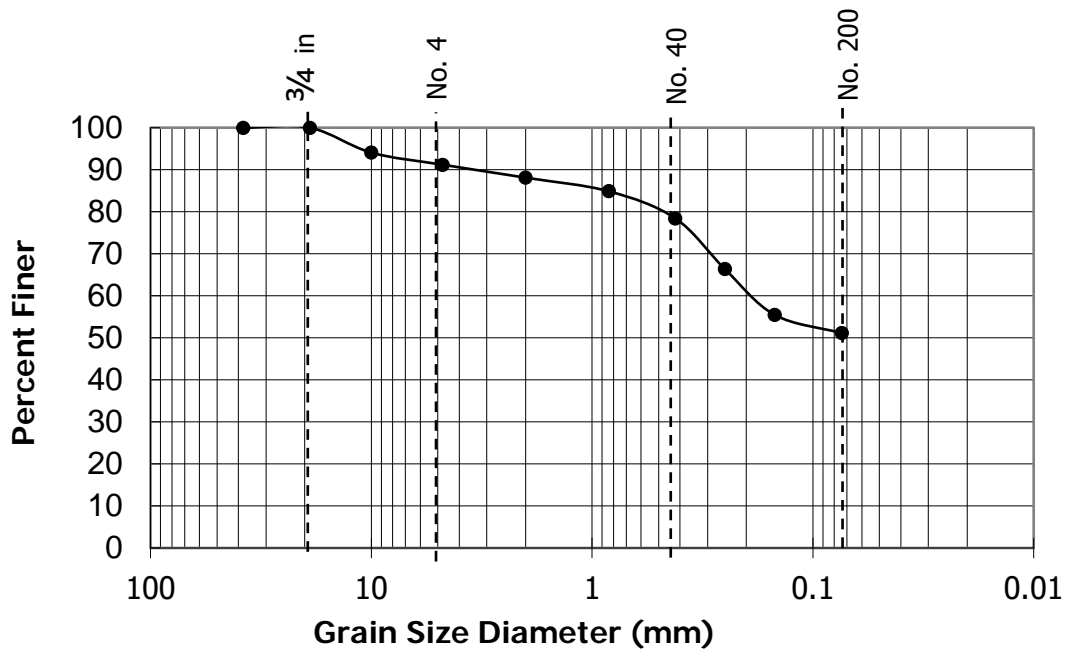

SIEVE	% Passing
1 1/2 "	100
3/4"	100
3/8"	94
#4	91
#10	88
#20	85
#40	78
#60	66
#100	55
#200	51
Pan	--

USCS Group Symbol	CL
USCS Group Name	sandy Lean Clay
Cu	---
Cc	---
LL	36
PI	17
Gravel	8.8
Sand	40.1
Fines	51.1
AASHTO Classification	A-6
Color	Brownish Gray

Test Method: ASTM D 422

Soil Classification by ASTM D2487 and AASHTO M 145

Tested by: _____

Reviewed by:

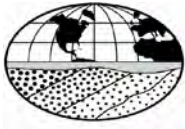

LIQUID AND PLASTIC LIMIT - ASTM D4318			
Project No.	14189	Project Name	Columbia Pike Multimodal St. Improvements
Test Boring No.	FB-18	Depth (Feet)	0.0'-5.0'
Lab Order No.	3480-12	Date	3/6/2015

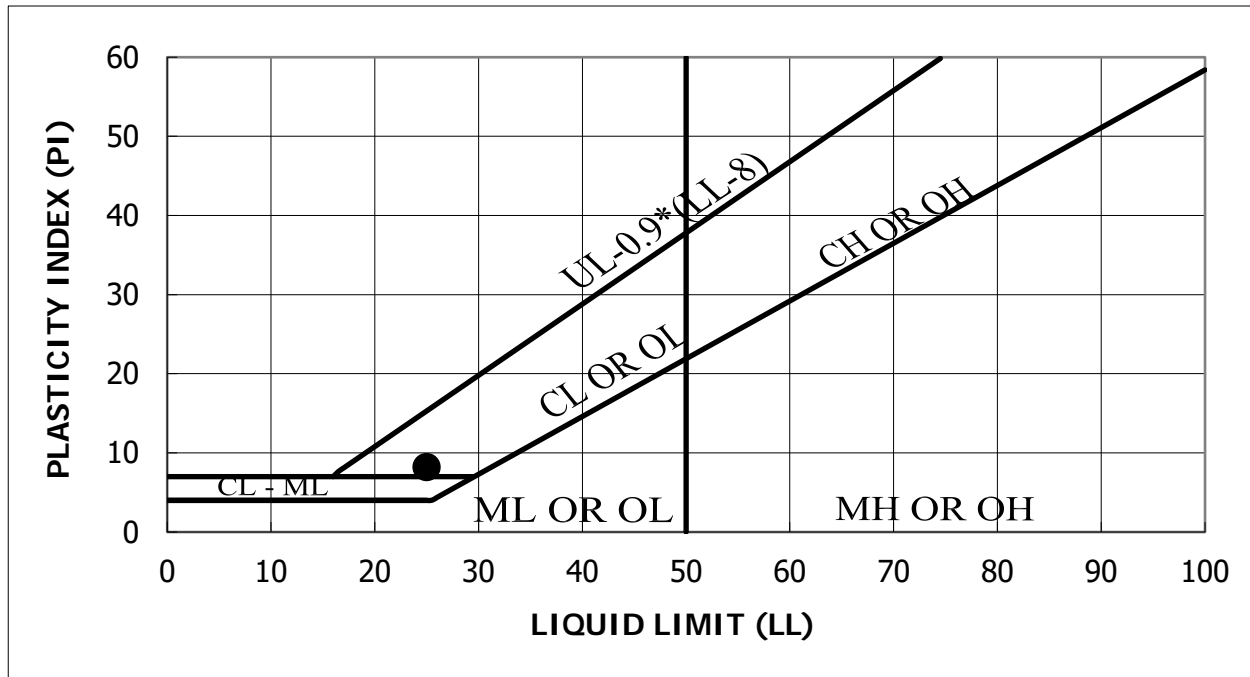

Material Description	LL	PL	PI	% Passing		USCS	w (%)
				#4	#200		
Lean Clay	25	17	8	99.9	86.7	CL	18.6
Color	Gray		AASHTO Classification			A-4	

Test Method: ASTM D 4318

Soil Classification by ASTM D2487 and AASHTO M 145

Tested by _____

Reviewed by Chic M. [Signature]

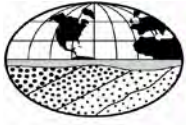

GRAIN SIZE ANALYSIS - ASTM D422			
Project No.	14189	Project Name	Columbia Pike Multimodal St. Improvements
Test Boring No.	FB-18	Depth (Feet)	0.0'-5.0'
Lab Order No.	3480-12	Date	3/6/2015

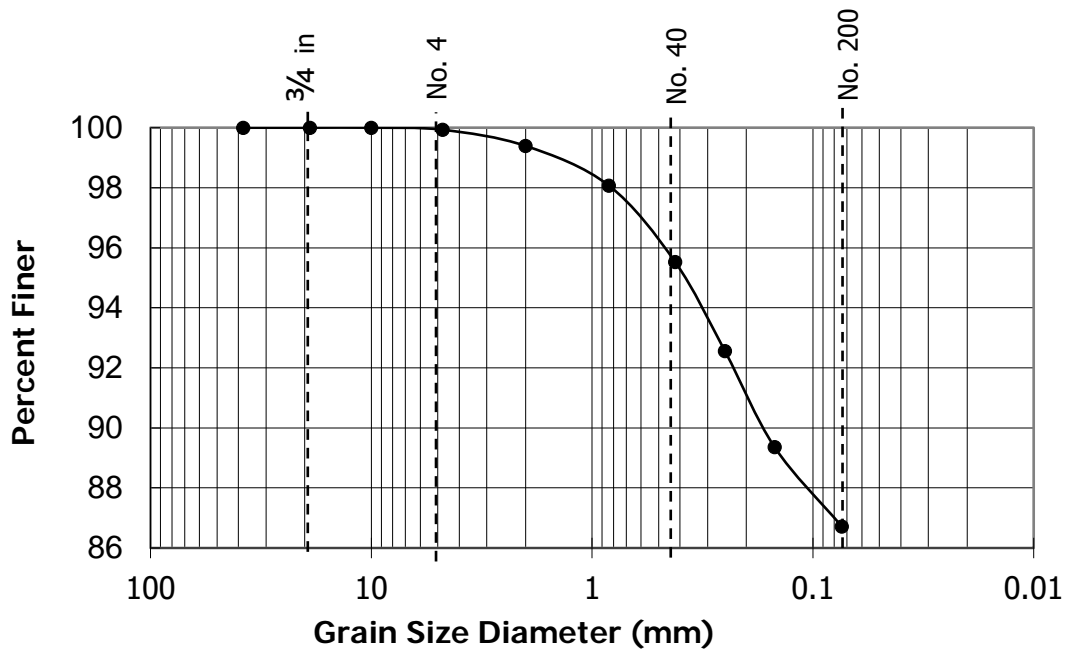

SIEVE	% Passing
1 1/2 "	100
3/4"	100
3/8"	100
#4	100
#10	99
#20	98
#40	96
#60	93
#100	89
#200	87
Pan	--

USCS Group Symbol	CL
USCS Group Name	Lean Clay
Cu	---
Cc	---
LL	25
PI	8
Gravel	0.1
Sand	13.2
Fines	86.7
AASHTO Classification	A-4
Color	Gray

Test Method: ASTM D 422

Soil Classification by ASTM D2487 and AASHTO M 145

Tested by: _____

Reviewed by:

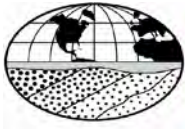

LIQUID AND PLASTIC LIMIT - ASTM D4318			
Project No.	14189	Project Name	Columbia Pike - Segment H/I
Test Boring No.	HB-5	Depth (Feet)	0.0'-5.0'
Lab Order No.	3468	Date	2/5/2015

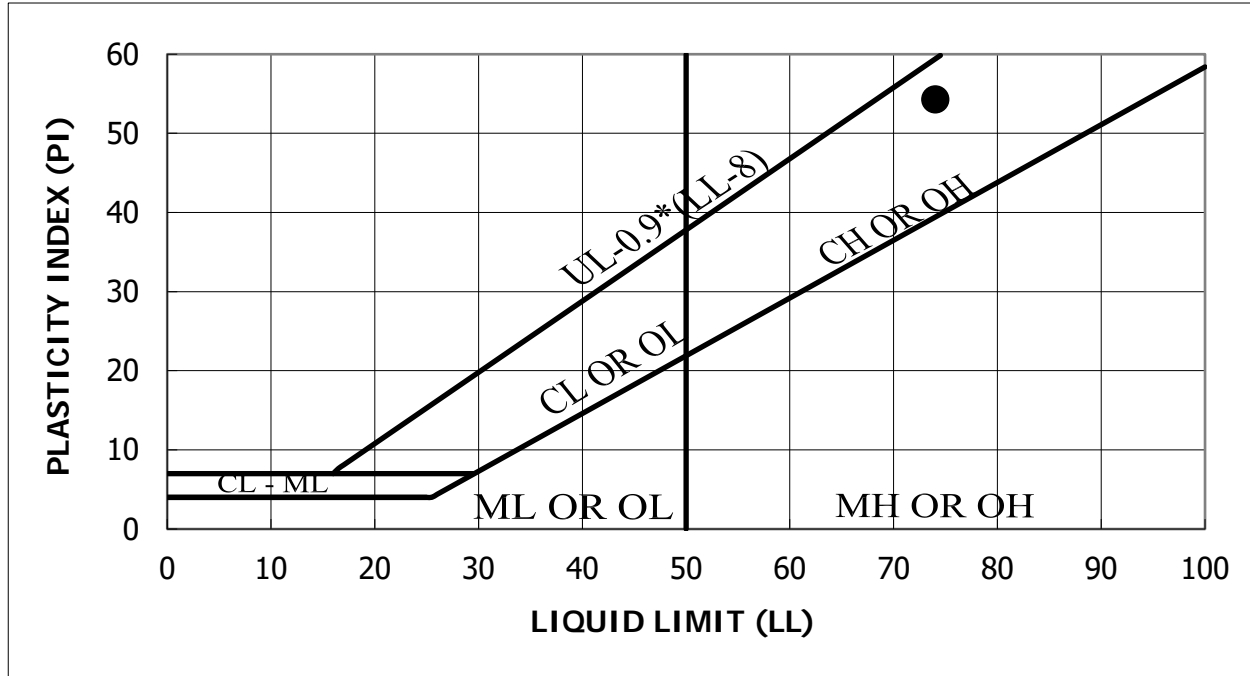

Material Description	LL	PL	PI	% Passing		USCS	w (%)
				#4	#200		
CLAYEY SAND	74	20	54	94.9	28.6	SC	17.3
Color	Gray		AASHTO Classification		A-2-7		

Test Method: ASTM D 4318

Soil Classification by ASTM D2487 and AASHTO M 145

Tested by _____

Reviewed by Shawn Harris



GRAIN SIZE ANALYSIS - ASTM D422			
Project No.	14189	Project Name	Columbia Pike - Segment H/I
Test Boring No.	HB-5	Depth (Feet)	0.0'-5.0'
Lab Order No.	3468	Date	2/5/2015

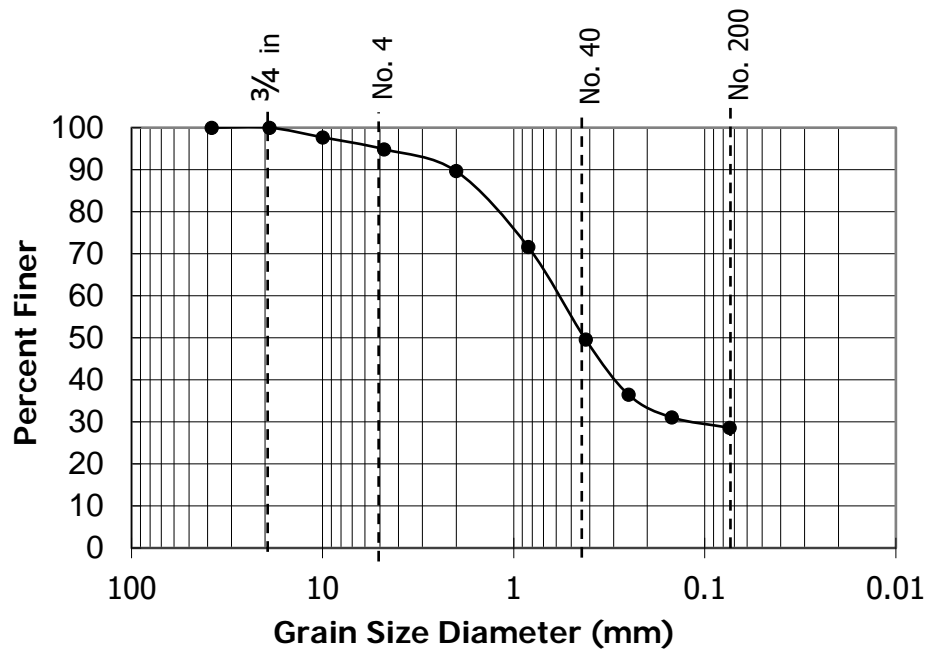

SIEVE	% Passing
1 1/2 "	100
3/4"	100
3/8"	98
#4	95
#10	90
#20	72
#40	50
#60	36
#100	31
#200	29
Pan	--

USCS Group Symbol	SC
USCS Group Name	CLAYEY SAND
Cu	---
Cc	---
LL	74
PI	54
Gravel	5.1
Sand	66.3
Fines	28.6
AASHTO Classification	A-2-7
Color	Gray

Test Method: ASTM D 422

Soil Classification by ASTM D2487 and AASHTO M 145

Tested by: _____

Reviewed by: _____

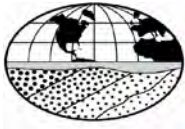

LIQUID AND PLASTIC LIMIT - ASTM D4318			
Project No.	14189	Project Name	Columbia Pike Multimodal
Test Boring No.	IRW-1	Depth (Feet)	5.0-6.5
Lab Order No.	3462-7	Date	2/2/2015

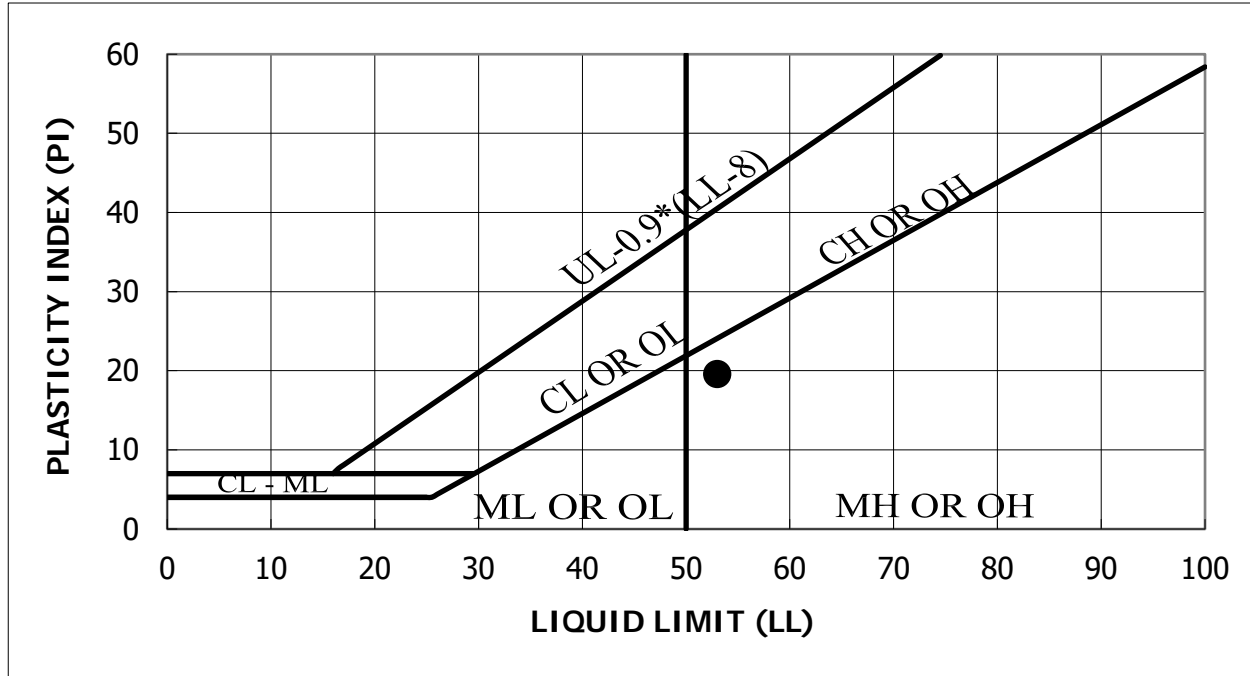

Material Description	LL	PL	PI	% Passing		USCS	w (%)
				#4	#200		
SILTY SAND	53	33	20	100.0	21.3	SM	18.7
Color	Brownish Gray		AASHTO Classification		A-2-7		

Test Method: ASTM D 4318

Soil Classification by ASTM D2487 and AASHTO M 145

Tested by _____

Reviewed by Shan Harris

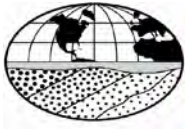

LIQUID AND PLASTIC LIMIT - ASTM D4318			
Project No.	14189	Project Name	Columbia Pike Multimodal
Test Boring No.	IB-2	Depth (Feet)	0.0-5.0
Lab Order No.	3462-13	Date	2/2/2015

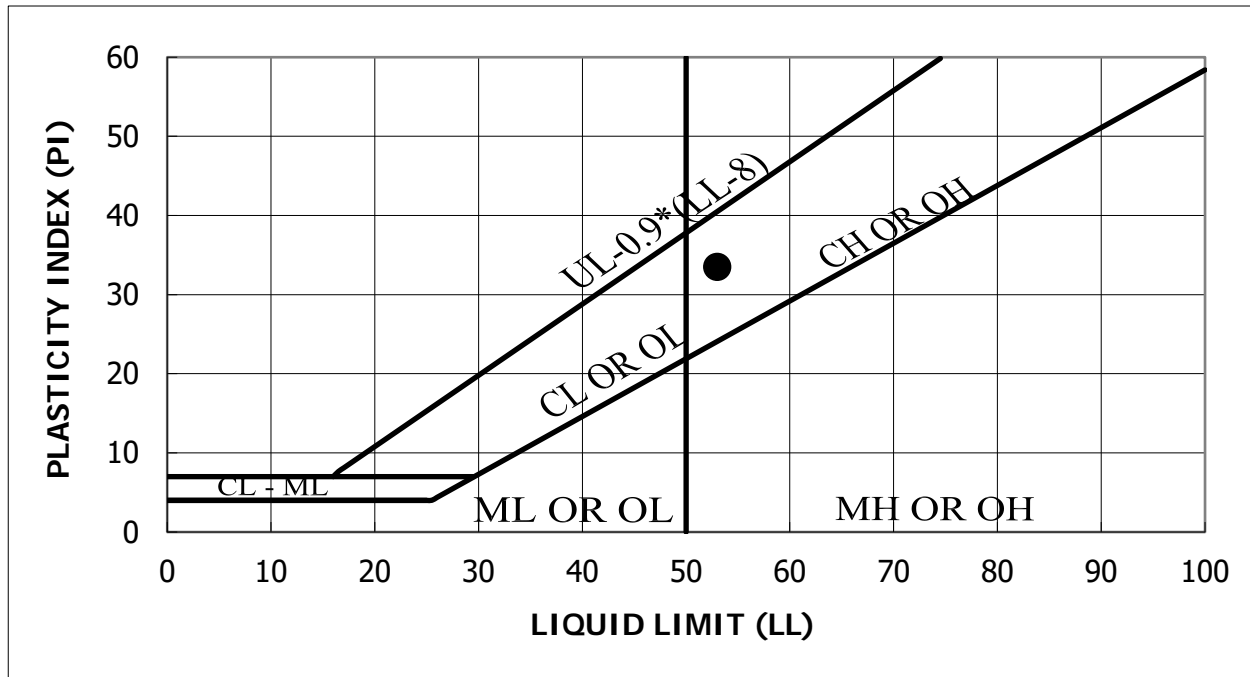

Material Description	LL	PL	PI	% Passing		USCS	w (%)
				#4	#200		
sandy Fat Clay	53	20	33	98.2	51.0	CH	24.7
Color	Brownish Gray		AASHTO Classification			A-7-6	

Test Method: ASTM D 4318

Soil Classification by ASTM D2487 and AASHTO M 145

Tested by _____

Reviewed by Shu Harris



GRAIN SIZE ANALYSIS - ASTM D422			
Project No.	14189	Project Name	Columbia Pike Multimodal
Test Boring No.	IB-2	Depth (Feet)	0.0-5.0
Lab Order No.	3462-13	Date	2/2/2015

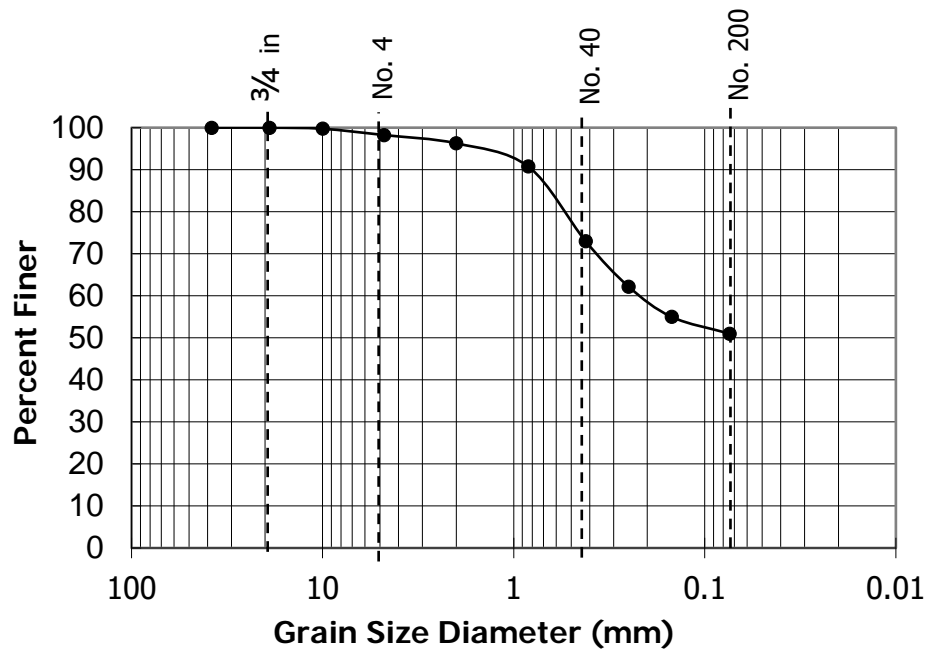

SIEVE	% Passing
1 1/2 "	100
3/4"	100
3/8"	100
#4	98
#10	96
#20	91
#40	73
#60	62
#100	55
#200	51
Pan	--

USCS Group Symbol	CH
USCS Group Name	sandy Fat Clay
Cu	---
Cc	---
LL	53
PI	33
Gravel	1.8
Sand	47.3
Fines	51.0
AASHTO Classification	A-7-6
Color	Brownish Gray

Test Method: ASTM D 422

Soil Classification by ASTM D2487 and AASHTO M 145

Tested by: _____

Reviewed by: _____

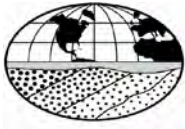

LIQUID AND PLASTIC LIMIT - ASTM D4318			
Project No.	14189	Project Name	Columbia Pike Multimodal
Test Boring No.	IB-9	Depth (Feet)	3462-12
Lab Order No.	3462-12	Date	2/2/2015

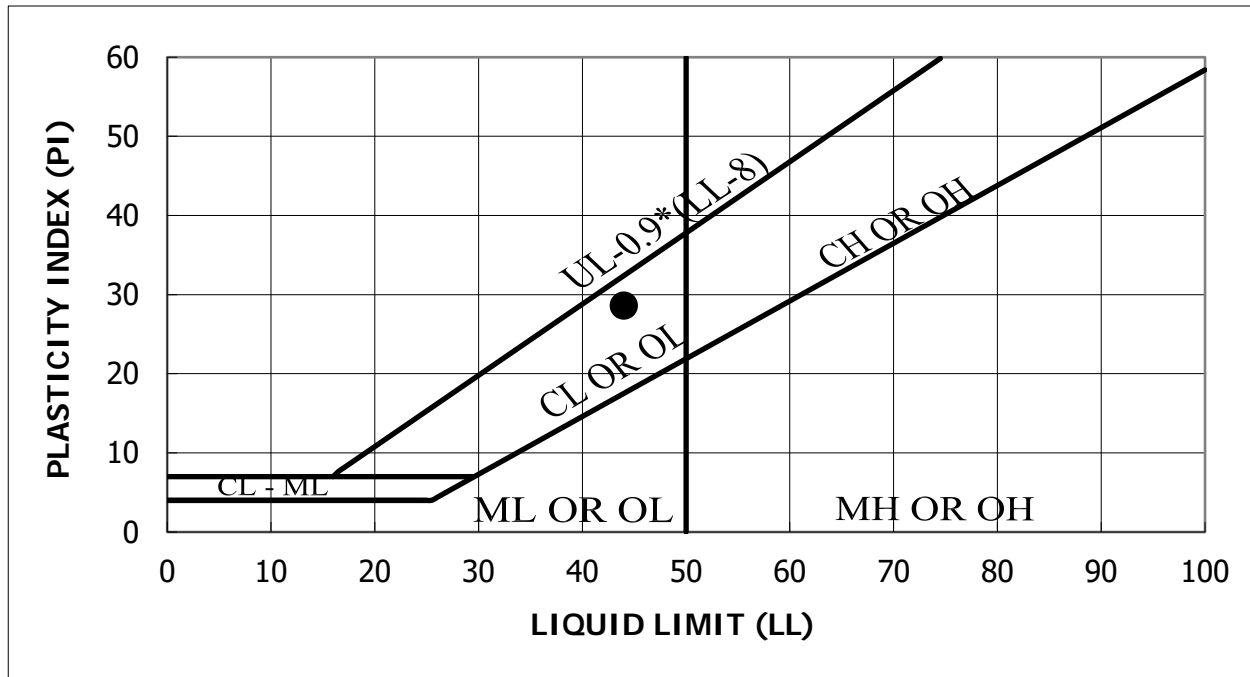

Material Description	LL	PL	PI	% Passing		USCS	w (%)
				#4	#200		
CLAYEY SAND with gravel	44	15	29	73.8	31.7	SC	7.6
Color	Gray		AASHTO Classification		A-2-7		

Test Method: ASTM D 4318

Soil Classification by ASTM D2487 and AASHTO M 145

Tested by _____

Reviewed by Shawn Harris



GRAIN SIZE ANALYSIS - ASTM D422			
Project No.	14189	Project Name	Columbia Pike Multimodal
Test Boring No.	IB-9	Depth (Feet)	3462-12
Lab Order No.	3462-12	Date	2/2/2015

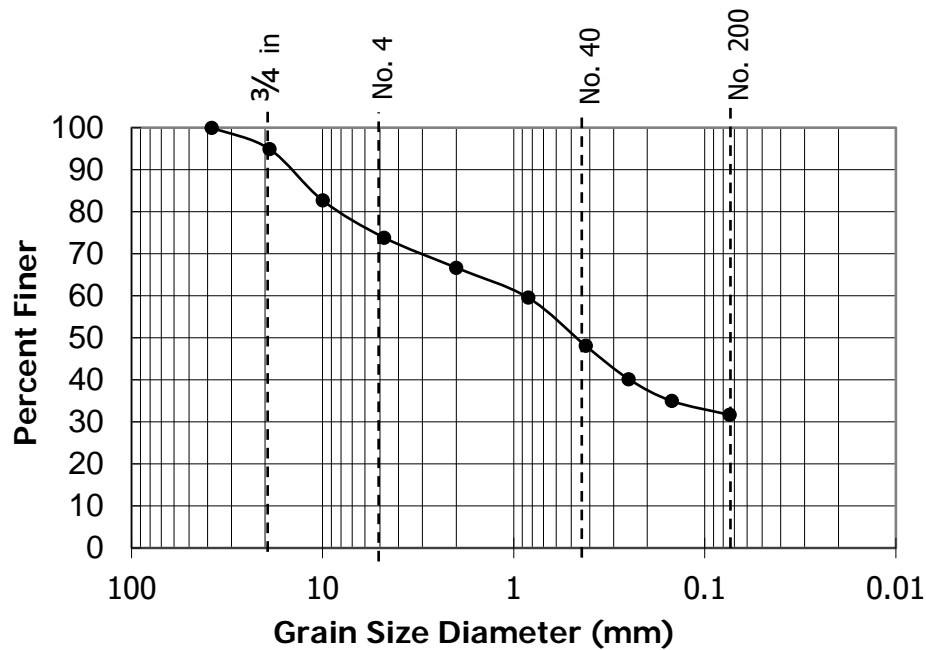

SIEVE	% Passing
1 1/2 "	100
3/4"	95
3/8"	83
#4	74
#10	67
#20	60
#40	48
#60	40
#100	35
#200	32
Pan	--

USCS Group Symbol	SC
USCS Group Name	CLAYEY SAND with gravel
Cu	---
Cc	---
LL	44
PI	29
Gravel	26.2
Sand	42.2
Fines	31.7
AASHTO Classification	A-2-7
Color	Gray

Test Method: ASTM D 422

Soil Classification by ASTM D2487 and AASHTO M 145

Tested by: _____

Reviewed by:

Shawn Harris



CALIFORNIA BEARING RATIO (CBR) TEST - ASTM- D1833

Project No.	14189	Project Name	Columbia Pike Multimodal St. Improvement
Test Boring No.	AB-12	Depth (Feet)	0.0'-5.0'
Lab Order No.	3754-2	Date	3/17/2016

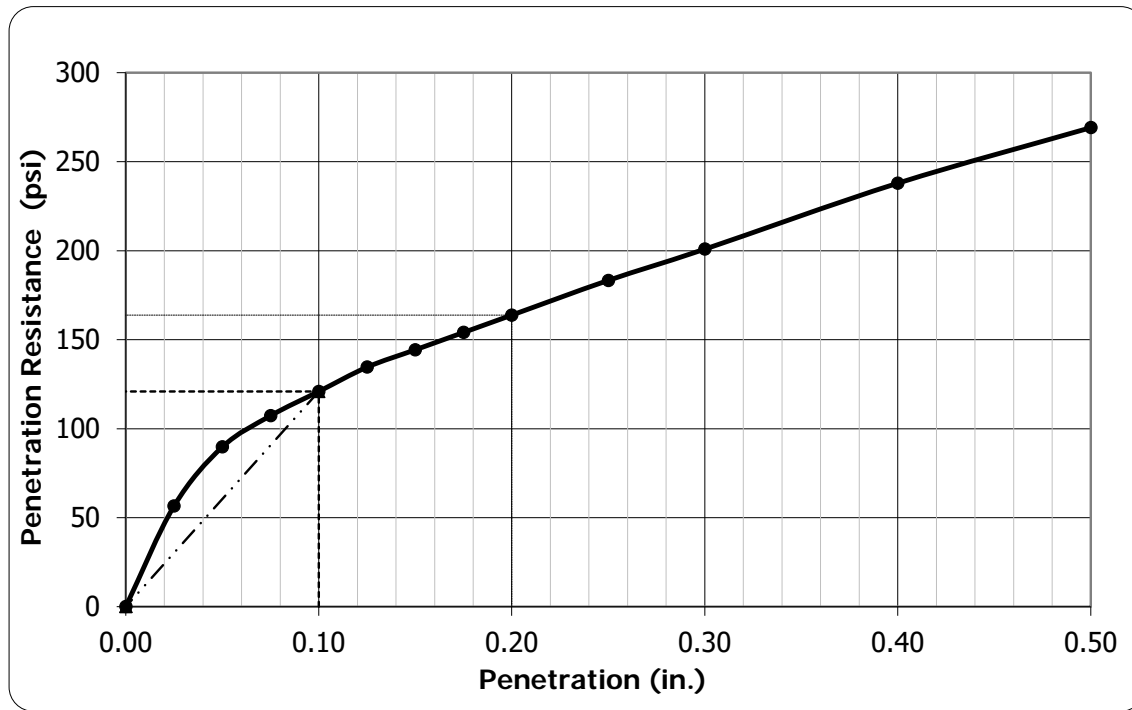

Molded	
Dry Density (pcf)	122.6
Moisture (%)	11.9
Percent of Max. Density (%)	99.7

Linearity Correction	0.000
Surcharge (lbs)	10
Max Swell (%)	0.2

Soaked	
Dry Density (pcf)	122.4
Moisture (%)	14.7
Percentage of Max. Density (%)	99.5

Material Description	CLAYEY SAND
USCS	SC
Max Density	123
Optimum Moisture (%)	12
LL	50
PI	26
Color	Brown

CBR (%)	
0.1 in.	12.1
0.2 in.	10.9

Reviewed by: Lindsay Bartz

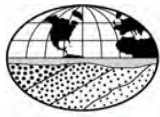

CALIFORNIA BEARING RATIO (CBR) TEST - ASTM- D1833

Project No.	14189	Project Name	Columbia Pike Multimodal St. Improvement
Test Boring No.	AB-15	Depth (Feet)	0.0'-5.0'
Lab Order No.	3754-7	Date	3/17/2016

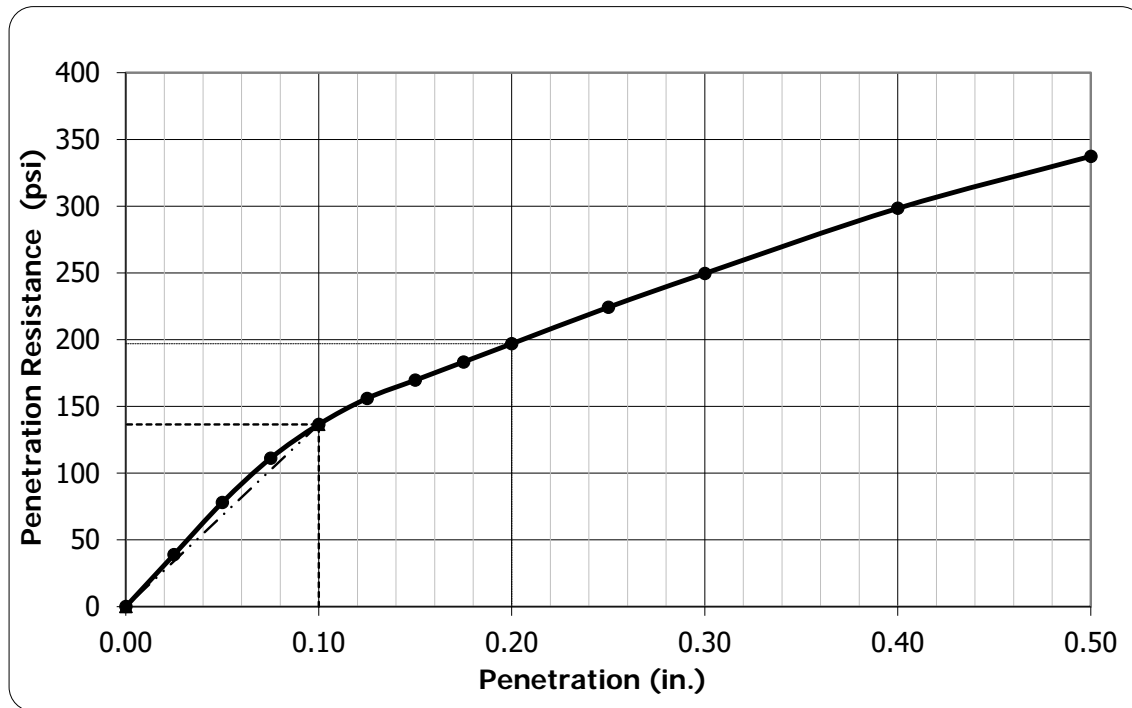

Molded	
Dry Density (pcf)	127.3
Moisture (%)	9.0
Percent of Max. Density (%)	100.3

Linearity Correction	0.000
Surcharge (lbs)	10
Max Swell (%)	0.2

Soaked	
Dry Density (pcf)	127.1
Moisture (%)	12.6
Percentage of Max. Density (%)	100.1

Material Description	CLAYEY SAND
USCS	SC
Max Density	127
Optimum Moisture (%)	9
LL	37
PI	20
Color	Brown

CBR (%)	
0.1 in.	13.7
0.2 in.	13.1

Reviewed by:

Lindsay Bantz



CALIFORNIA BEARING RATIO (CBR) TEST - VTM-008			
Project No.	14189	Project Name	Columbia Pike Multimodal St. Improvements
Test Boring No.	CRW-2	Depth (Feet)	0.0'-5.0'
Lab Order No.	3486-13	Date	3/5/2015

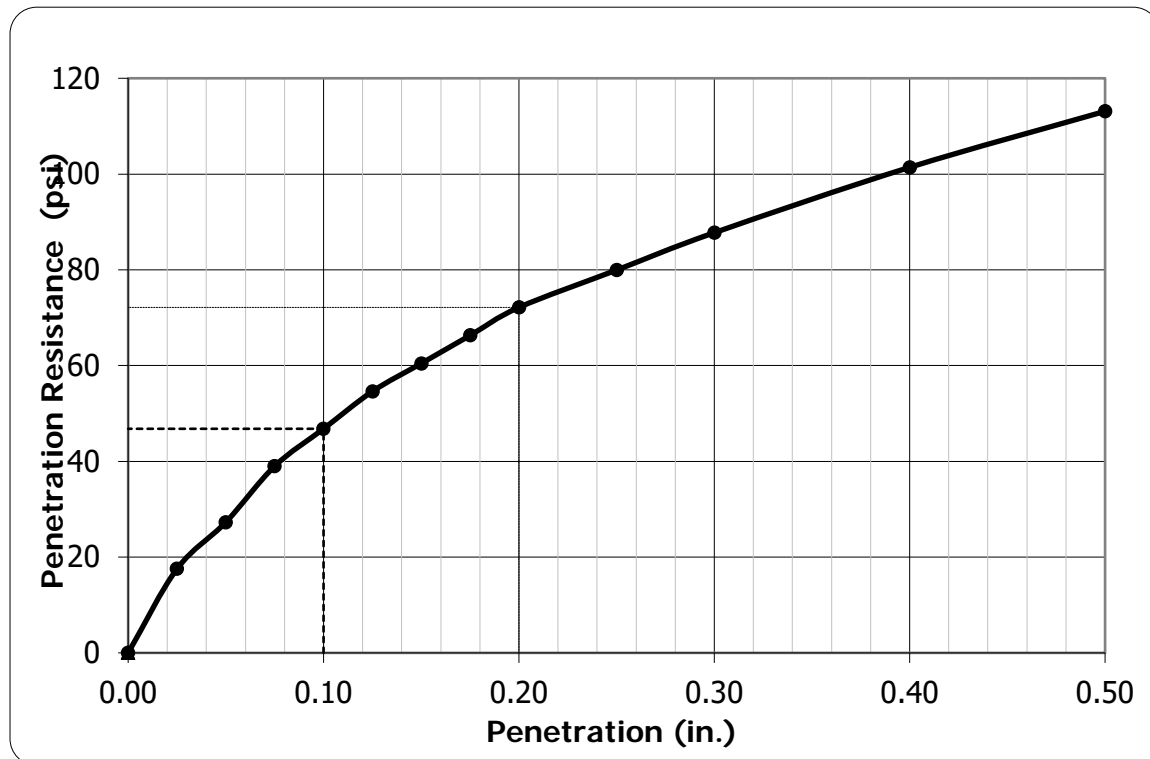

Molded	
Dry Density (pcf)	120.1
Moisture (%)	12.7
Percent of Max. Density (%)	99.3

Soaked	
Dry Density (pcf)	119.8
Moisture (%)	14.9
Percentage of Max. Density (%)	99.0

CBR (%)	
0.1 in.	4.7
0.2 in.	4.8

Linearity Correction	0.000
Surcharge (lbs)	10
Max Swell (%)	0.3

Material Description	CLAYEY SAND
USCS	SC
Max Density	121
Optimum Moisture (%)	13
LL	34
PI	19
Color	Brown

Tested by: _____

Reviewed by: Shu Han



CALIFORNIA BEARING RATIO (CBR) TEST - VTM-008			
Project No.	14189	Project Name	Columbia Pike Multimodal St. Improvements
Test Boring No.	CB-5	Depth (Feet)	0.0'-5.0'
Lab Order No.	3486-12	Date	3/5/2015

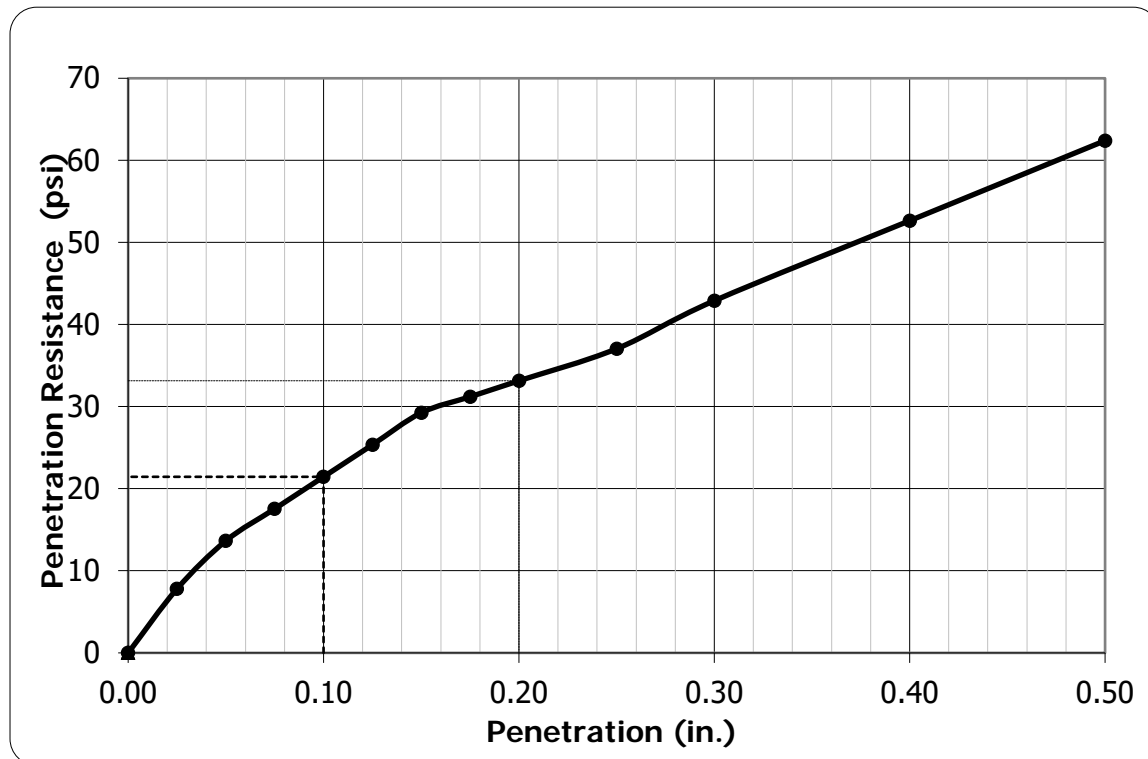

Molded	
Dry Density (pcf)	122.8
Moisture (%)	11.4
Percent of Max. Density (%)	99.0

Soaked	
Dry Density (pcf)	119.9
Moisture (%)	17.9
Percentage of Max. Density (%)	96.7

CBR (%)	
0.1 in.	2.1
0.2 in.	2.2

Linearity Correction	0.000
Surcharge (lbs)	10
Max Swell (%)	2.4

Material Description	sandy Lean Clay
USCS	CL
Max Density	124
Optimum Moisture (%)	11
LL	41
PI	23
Color	Light Grayish Brown

Tested by: _____

Reviewed by: John Harris



CALIFORNIA BEARING RATIO (CBR) TEST - VTM-008			
Project No.	14189	Project Name	Columbia Pike Street Improvements
Test Boring No.	CB-8	Depth (Feet)	0.0'-5.0'
Lab Order No.	3483-2	Date	3/5/2014

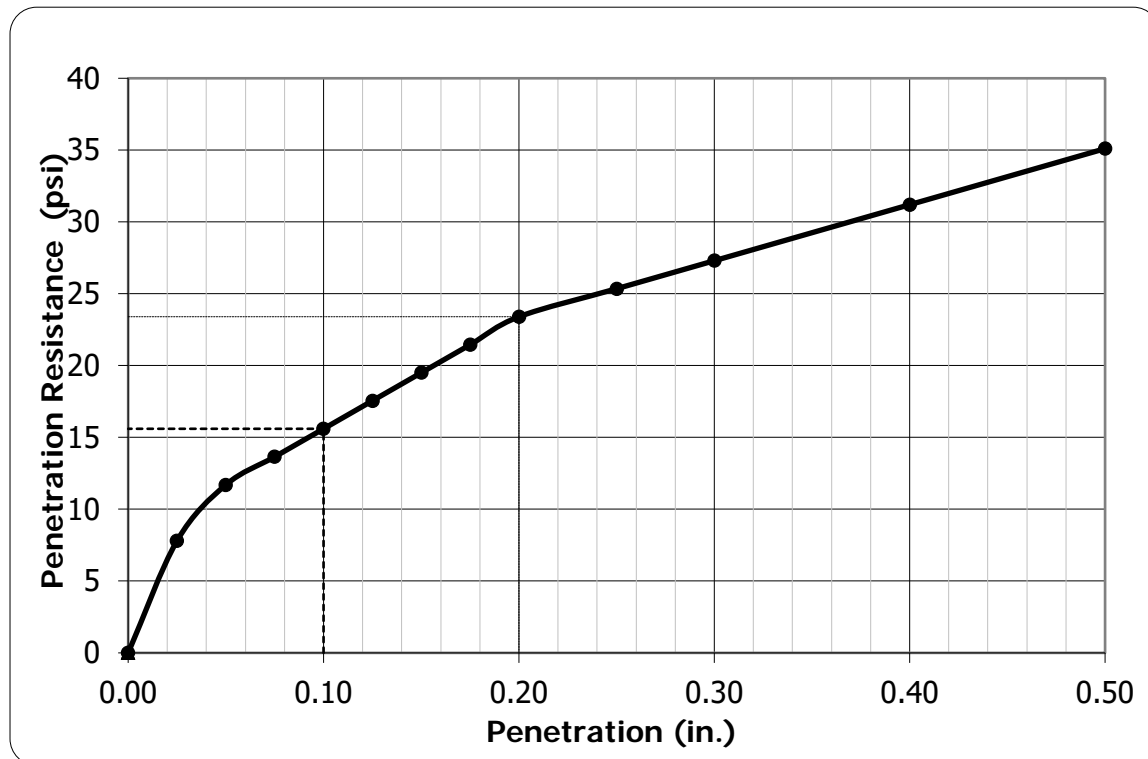

Molded	
Dry Density (pcf)	112.7
Moisture (%)	15.1
Percent of Max. Density (%)	99.7

Soaked	
Dry Density (pcf)	111.7
Moisture (%)	16.8
Percentage of Max. Density (%)	98.8

CBR (%)	
0.1 in.	1.6
0.2 in.	1.6

Linearity Correction	0.000
Surcharge (lbs)	10
Max Swell (%)	0.9

Material Description	CLAYEY SAND
USCS	SC
Max Density	113
Optimum Moisture (%)	15
LL	30
PI	15
Color	Dark Brownish Gray

Tested by: _____

Reviewed by: John Harris



CALIFORNIA BEARING RATIO (CBR) TEST - VTM-008			
Project No.	14189	Project Name	Columbia Pike Street Improvements
Test Boring No.	DB-2	Depth (Feet)	0.0'-5.0'
Lab Order No.	3483-1	Date	3/5/2014

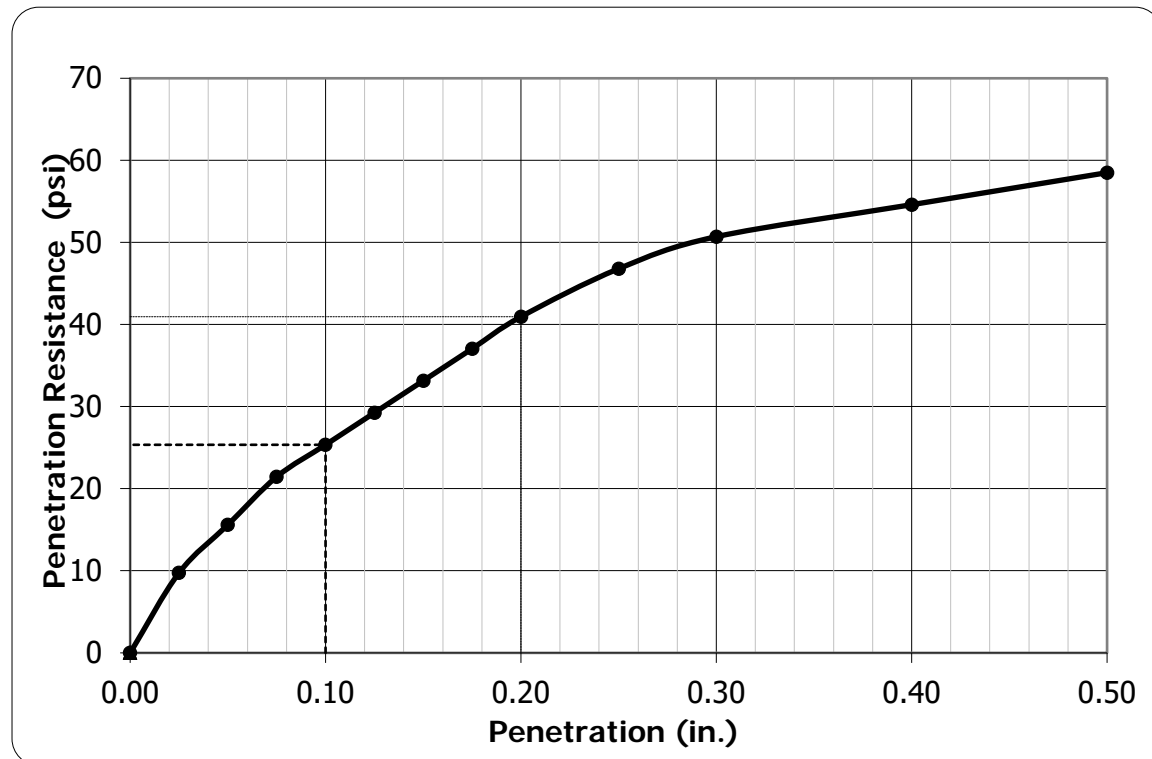

Molded	
Dry Density (pcf)	126.8
Moisture (%)	9.1
Percent of Max. Density (%)	99.8

Soaked	
Dry Density (pcf)	120.3
Moisture (%)	24.2
Percentage of Max. Density (%)	94.7

CBR (%)	
0.1 in.	2.5
0.2 in.	2.7

Linearity Correction	0.000
Surcharge (lbs)	10
Max Swell (%)	5.4

Material Description	sandy Fat Clay with gravel
USCS	CH
Max Density	127
Optimum Moisture (%)	9
LL	51
PI	30
Color	Orange Brown

Tested by: _____

Reviewed by: Shun Harris



CALIFORNIA BEARING RATIO (CBR) TEST - VTM-008			
Project No.	14189	Project Name	Columbia Pike Multimodal
Test Boring No.	DB-6	Depth (Feet)	0.0'-5.0'
Lab Order No.	3481-2	Date	3/3/2015

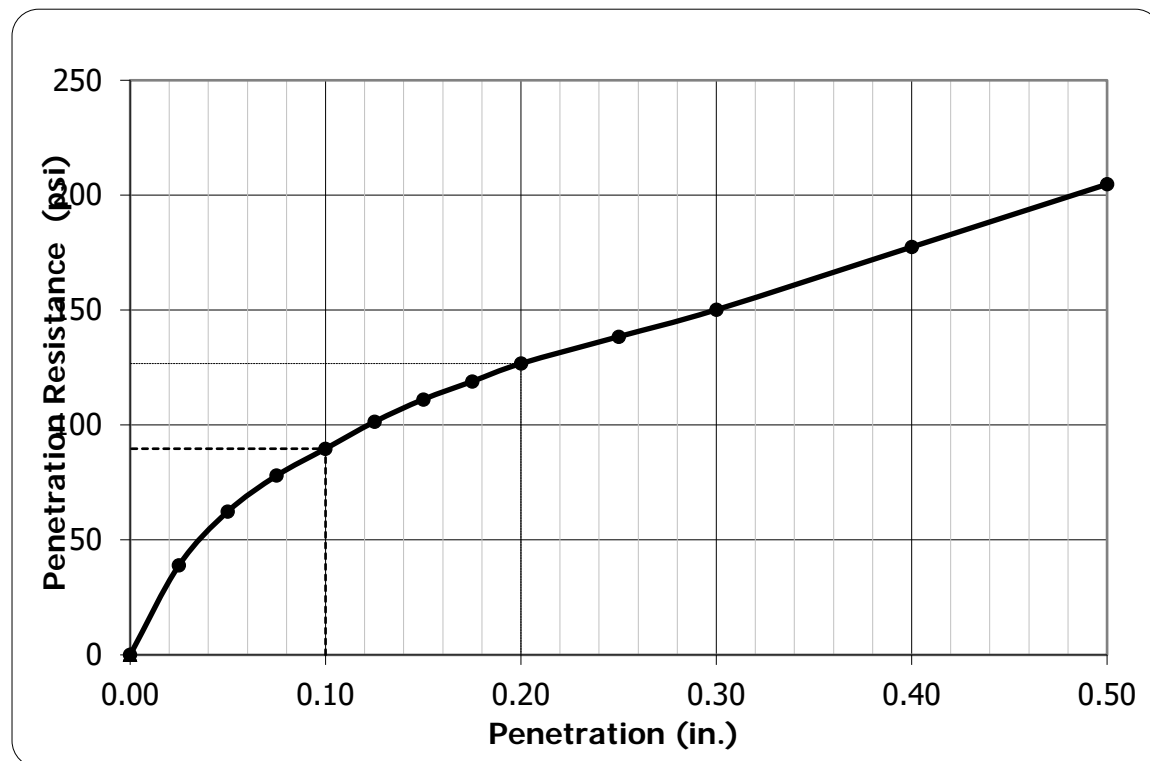

Molded	
Dry Density (pcf)	129.3
Moisture (%)	8.0
Percent of Max. Density (%)	100.2

Soaked	
Dry Density (pcf)	128.2
Moisture (%)	12.8
Percentage of Max. Density (%)	99.4

CBR (%)	
0.1 in.	9.0
0.2 in.	8.5

Linearity Correction	0.000
Surcharge (lbs)	10
Max Swell (%)	0.8

Material Description	CLAYEY SAND with gravel
USCS	SC
Max Density	129
Optimum Moisture (%)	8
LL	31
PI	16
Color	Dark Gray

Tested by: _____

Reviewed by: Shun Havis



CALIFORNIA BEARING RATIO (CBR) TEST - VTM-008			
Project No.	14189	Project Name	Columbia Pike Multimodal
Test Boring No.	DB-10	Depth (Feet)	0.0'-5.0'
Lab Order No.	3481-1	Date	3/3/2015

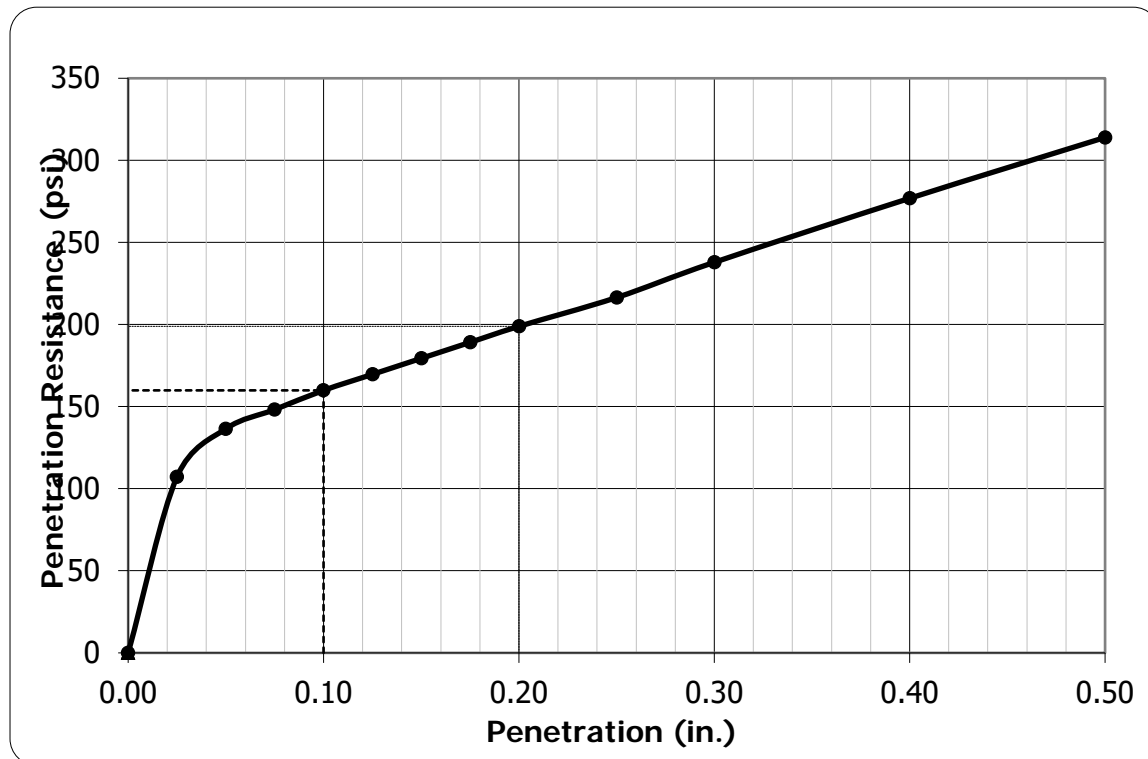

Molded	
Dry Density (pcf)	123.2
Moisture (%)	10.0
Percent of Max. Density (%)	99.3

Soaked	
Dry Density (pcf)	122.9
Moisture (%)	12.7
Percentage of Max. Density (%)	99.1

CBR (%)	
0.1 in.	16.0
0.2 in.	13.3

Linearity Correction	0.000
Surcharge (lbs)	10
Max Swell (%)	0.2

Material Description	CLAYEY SAND
USCS	SC
Max Density	124
Optimum Moisture (%)	10
LL	27
PI	13
Color	Brownish Gray

Tested by: _____

Reviewed by: Shun Harris



CALIFORNIA BEARING RATIO (CBR) TEST - VTM-008			
Project No.	14189	Project Name	Columbia Pike Multimodal St. Improvements
Test Boring No.	FB-2	Depth (Feet)	0.0'-5.0'
Lab Order No.	3480-14	Date	3/6/2015

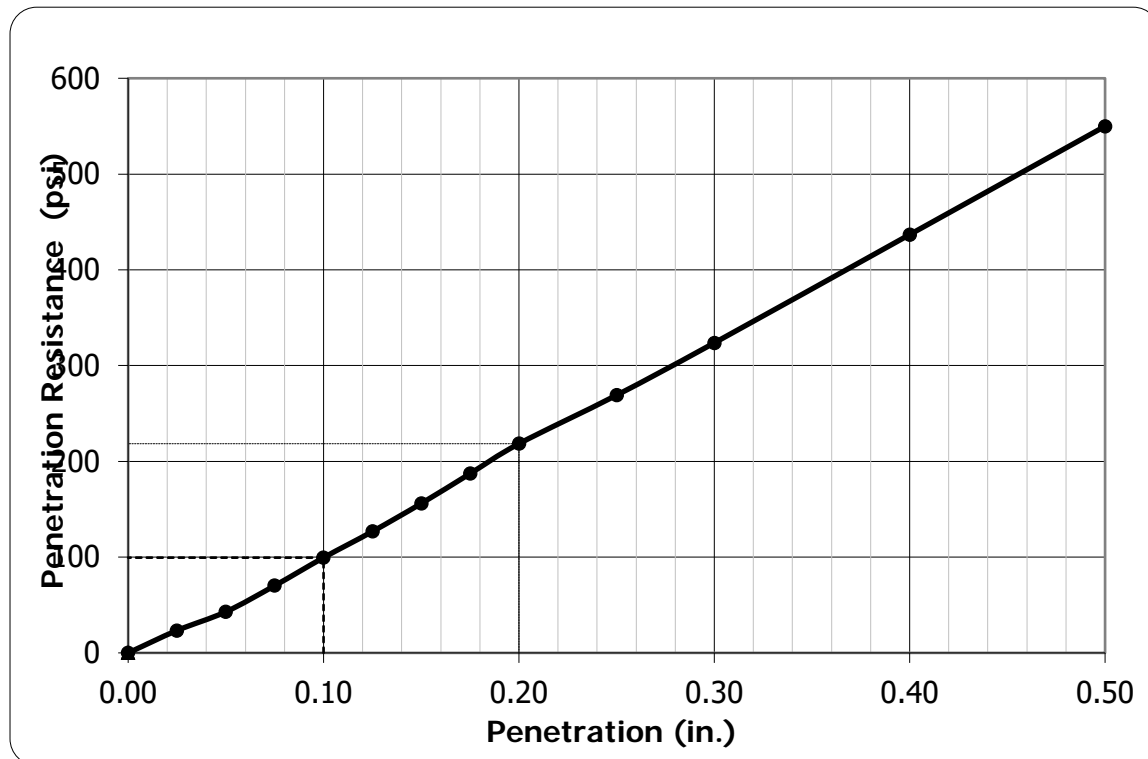

Molded	
Dry Density (pcf)	130.6
Moisture (%)	9.4
Percent of Max. Density (%)	99.7

Soaked	
Dry Density (pcf)	130.5
Moisture (%)	10.3
Percentage of Max. Density (%)	99.6

CBR (%)	
0.1 in.	9.9
0.2 in.	14.6

Linearity Correction	0.000
Surcharge (lbs)	10
Max Swell (%)	0.1

Material Description	CLAYEY SAND with gravel
USCS	SC
Max Density	131
Optimum Moisture (%)	9
LL	72
PI	46
Color	Dark Gray

Tested by: _____

Reviewed by: John Harris



CALIFORNIA BEARING RATIO (CBR) TEST - VTM-008			
Project No.	14189	Project Name	Columbia Pike Multimodal St. Improvements
Test Boring No.	FB-9	Depth (Feet)	0.0'-5.0'
Lab Order No.	3480-13	Date	3/6/2015

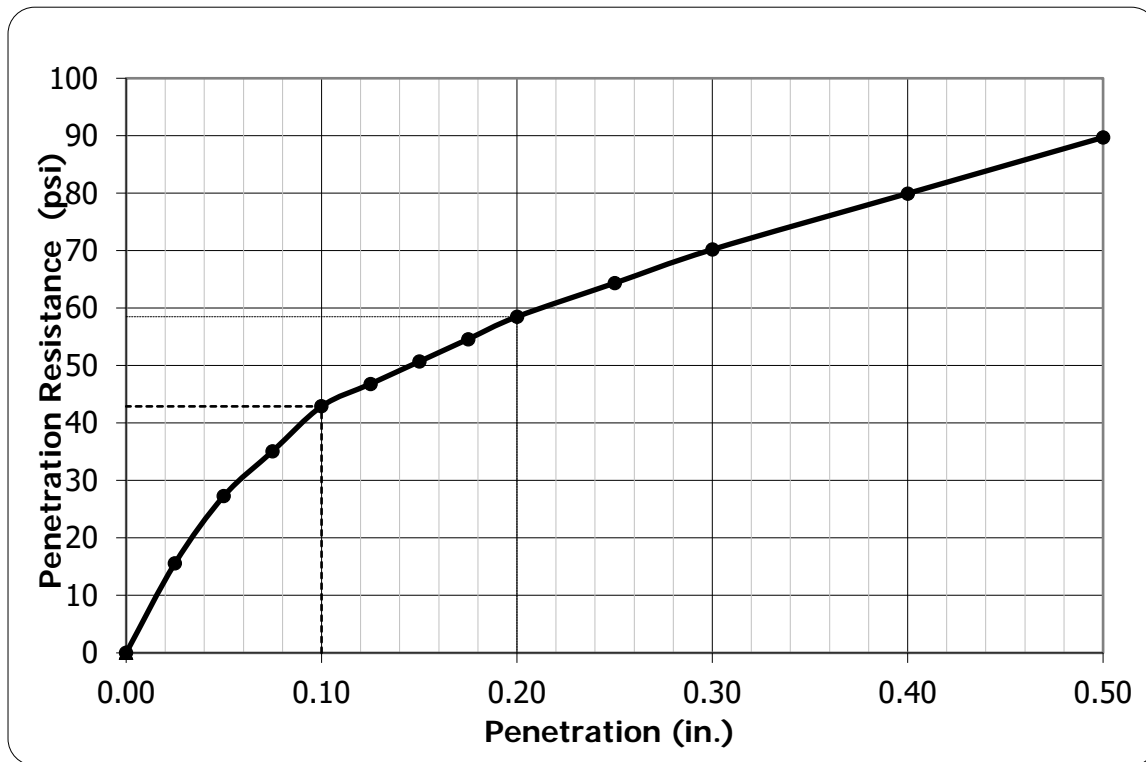

Molded	
Dry Density (pcf)	115.1
Moisture (%)	14.3
Percent of Max. Density (%)	100.1

Soaked	
Dry Density (pcf)	112.3
Moisture (%)	21.1
Percentage of Max. Density (%)	97.6

CBR (%)	
0.1 in.	4.3
0.2 in.	3.9

Linearity Correction	0.000
Surcharge (lbs)	10
Max Swell (%)	2.5

Material Description	sandy Lean Clay
USCS	CL
Max Density	115
Optimum Moisture (%)	14
LL	36
PI	17
Color	Brownish Gray

Tested by: _____

Reviewed by: John Harris



CALIFORNIA BEARING RATIO (CBR) TEST - VTM-008			
Project No.	14189	Project Name	Columbia Pike Multimodal St. Improvements
Test Boring No.	FB-18	Depth (Feet)	0.0'-5.0'
Lab Order No.	3480-12	Date	3/6/2015

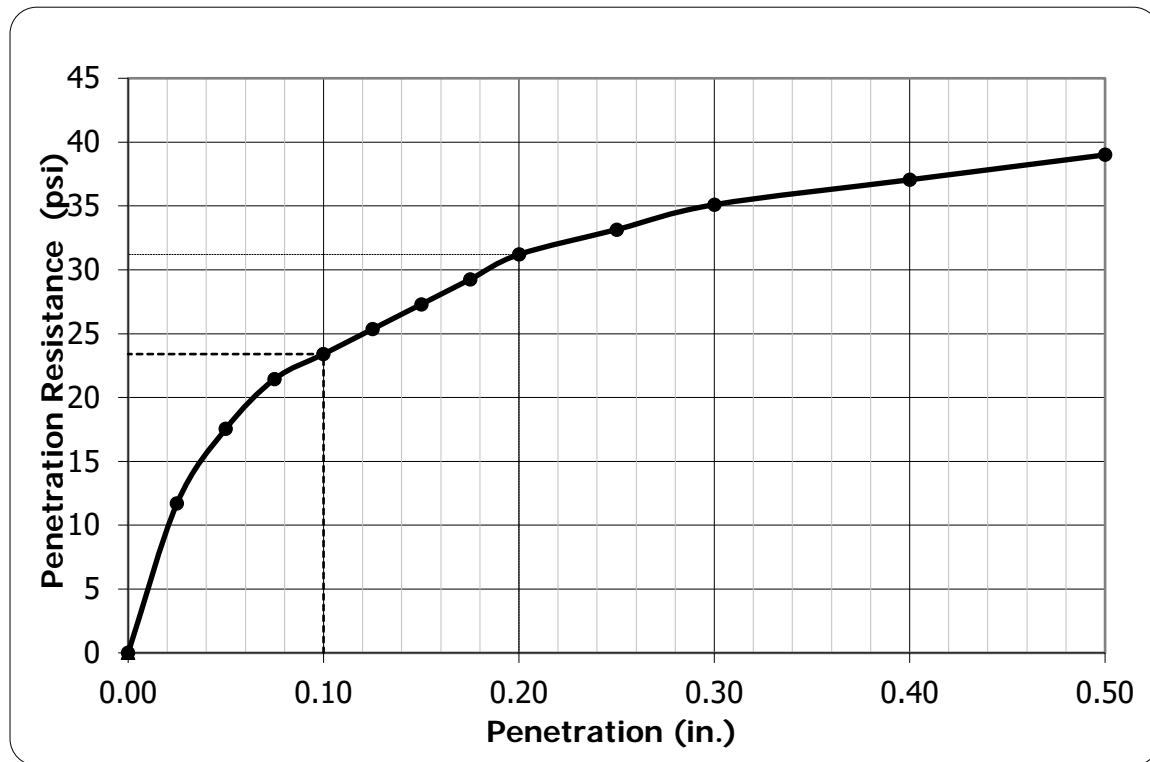

Molded	
Dry Density (pcf)	97.2
Moisture (%)	25.0
Percent of Max. Density (%)	100.2

Soaked	
Dry Density (pcf)	92.5
Moisture (%)	59.4
Percentage of Max. Density (%)	95.4

CBR (%)	
0.1 in.	2.3
0.2 in.	2.1

Linearity Correction	0.000
Surcharge (lbs)	10
Max Swell (%)	5.1

Material Description	Lean Clay
USCS	CL
Max Density	97
Optimum Moisture (%)	25
LL	25
PI	8
Color	Gray

Tested by: _____

Reviewed by: Shan Harris



CALIFORNIA BEARING RATIO (CBR) TEST - VTM-008			
Project No.	14189	Project Name	Columbia Pike - Segment H/I
Test Boring No.	HB-5	Depth (Feet)	0.0'-5.0'
Lab Order No.	3468	Date	2/5/2015

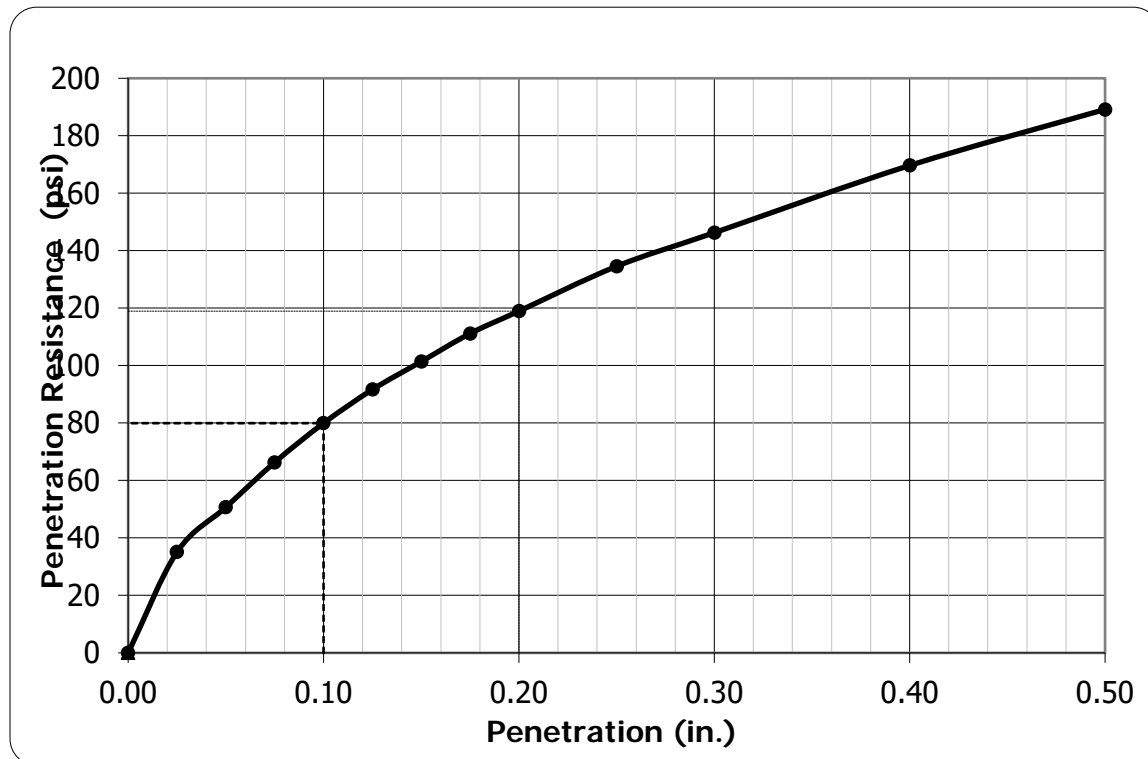

Molded	
Dry Density (pcf)	115.6
Moisture (%)	12.7
Percent of Max. Density (%)	100.5

Soaked	
Dry Density (pcf)	114.3
Moisture (%)	16.9
Percentage of Max. Density (%)	99.4

CBR (%)	
0.1 in.	8.0
0.2 in.	7.9

Linearity Correction	0.000
Surcharge (lbs)	10
Max Swell (%)	1.2

Material Description	CLAYEY SAND
USCS	SC
Max Density	115
Optimum Moisture (%)	13
LL	74
PI	54
Color	Gray

Tested by: _____

Reviewed by: Shan Harris



CALIFORNIA BEARING RATIO (CBR) TEST - VTM-008			
Project No.	14189	Project Name	Columbia Pike Multimodal
Test Boring No.	IB-2	Depth (Feet)	0.0-5.0
Lab Order No.	3462-13	Date	2/2/2015

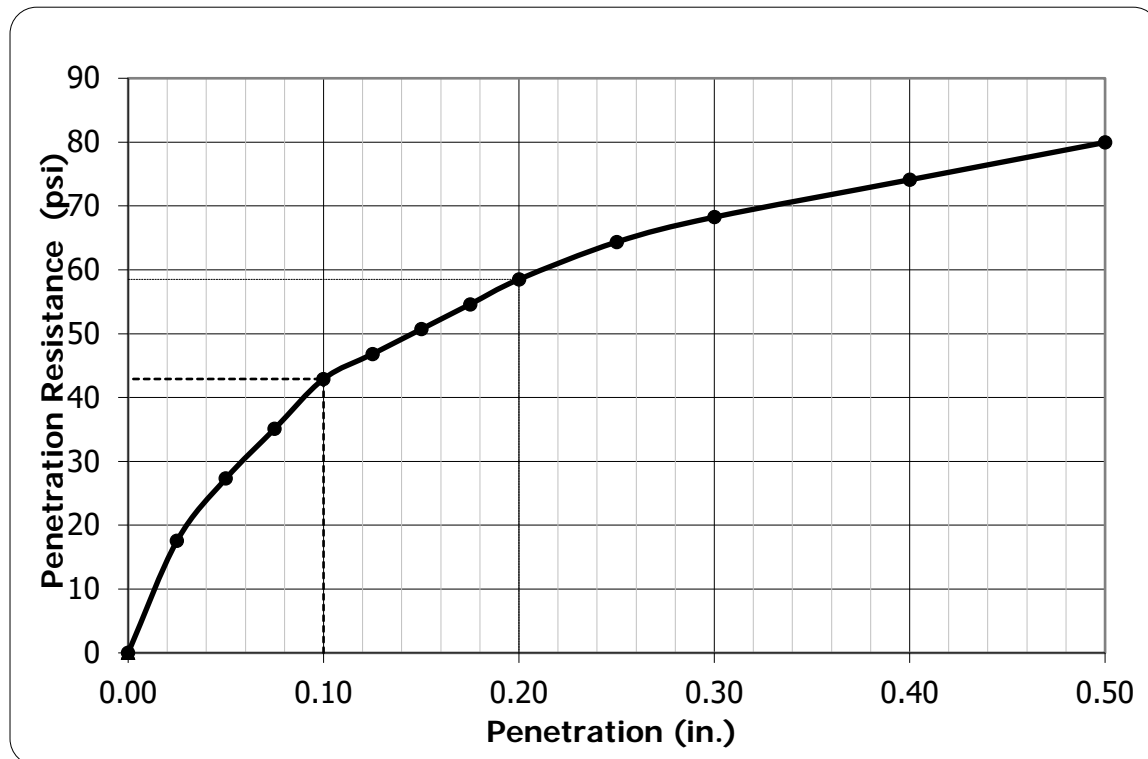

Molded	
Dry Density (pcf)	111.9
Moisture (%)	15.4
Percent of Max. Density (%)	99.9

Soaked	
Dry Density (pcf)	107.7
Moisture (%)	22.5
Percentage of Max. Density (%)	96.2

CBR (%)	
0.1 in.	4.3
0.2 in.	3.9

Linearity Correction	0.000
Surcharge (lbs)	10
Max Swell (%)	3.8

Material Description	sandy Fat Clay
USCS	CH
Max Density	112
Optimum Moisture (%)	15
LL	53
PI	33
Color	Brownish Gray

Tested by: _____

Reviewed by: Shan Harris



CALIFORNIA BEARING RATIO (CBR) TEST - VTM-008			
Project No.	14189	Project Name	Columbia Pike Multimodal
Test Boring No.	IB-9	Depth (Feet)	3462-12
Lab Order No.	3462-12	Date	2/2/2015

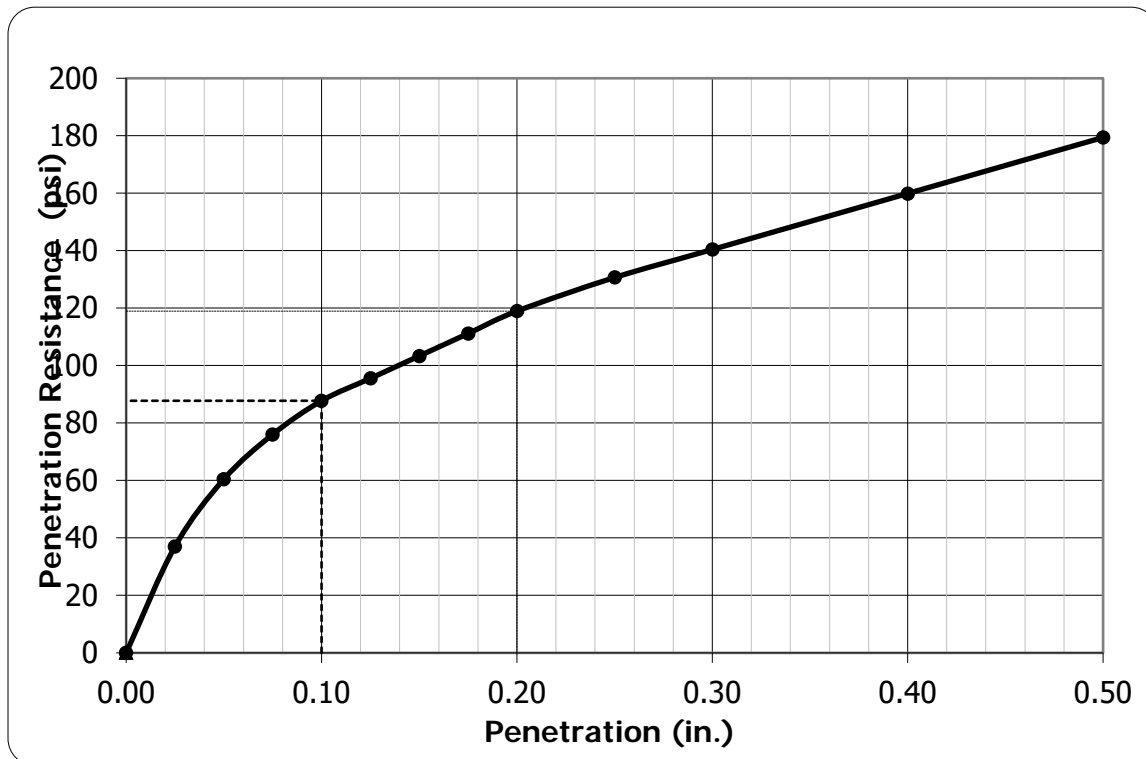

Molded	
Dry Density (pcf)	128.8
Moisture (%)	9.2
Percent of Max. Density (%)	99.9

Soaked	
Dry Density (pcf)	126.8
Moisture (%)	13.9
Percentage of Max. Density (%)	98.3

CBR (%)	
0.1 in.	8.8
0.2 in.	7.9

Linearity Correction	0.000
Surcharge (lbs)	10
Max Swell (%)	1.6

Material Description	CLAYEY SAND with gravel
USCS	SC
Max Density	129
Optimum Moisture (%)	9
LL	44
PI	29
Color	Gray

Tested by: _____

Reviewed by: Shun Harris



MOISTURE DENSITY RELATIONSHIP - VTM-001

Project No.	14189	Project Name	Columbia Pike Multimodal St. Improvements
Test Boring No.	AB-12	Depth (Feet)	0.0'-5.0'
Lab Order No.	3754-2	Date	3/17/2016

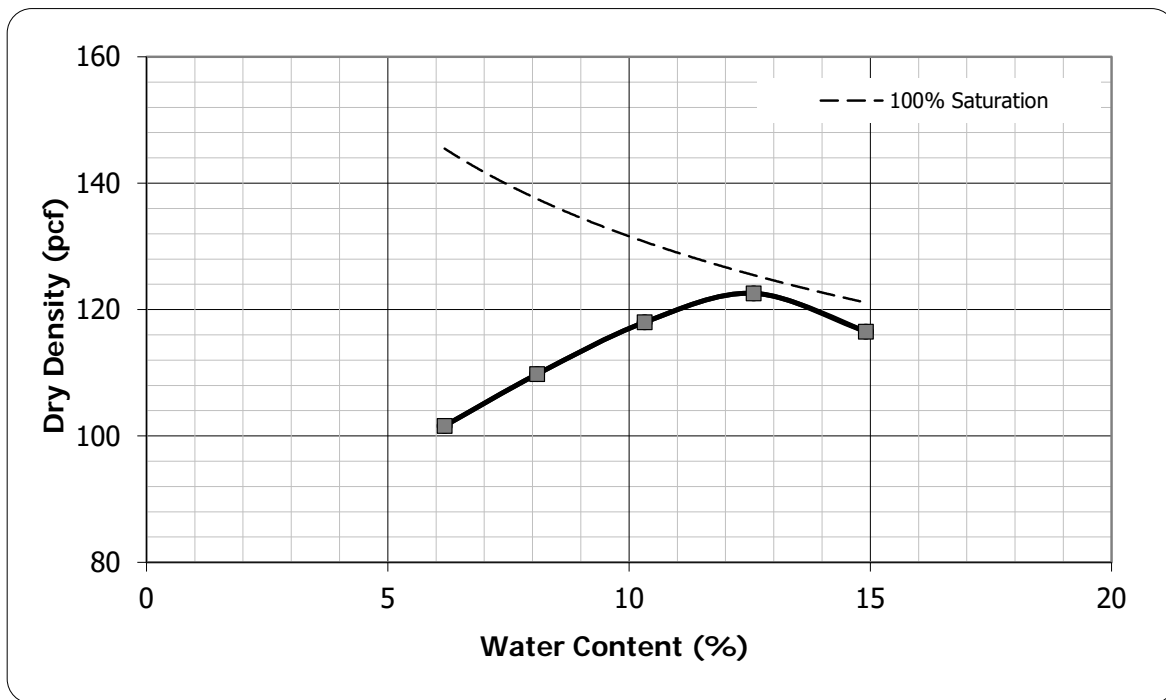

TEST RESULTS	Before Correc.		After Correc.					
Maximum Dry Density (pcf)	123		--		Color			
Optimum Moisture Content (%)	12		--		Brown			
Material	Classification		Nat. Moist. (%)	Sp. G. (Assumed)	LL	PI	% > #4	% < #200
CLAYEY SAND	USCS	AASHTO	16.1	2.7	50	26	5.5	31.8
	SC	A-2-7						

Reviewed by *Lindsay Bantz*



MOISTURE DENSITY RELATIONSHIP - VTM-001

Project No.	14189	Project Name	Columbia Pike Multimodal St. Improvements
Test Boring No.	AB-15	Depth (Feet)	0.0'-5.0'
Lab Order No.	3754-7	Date	3/17/2016

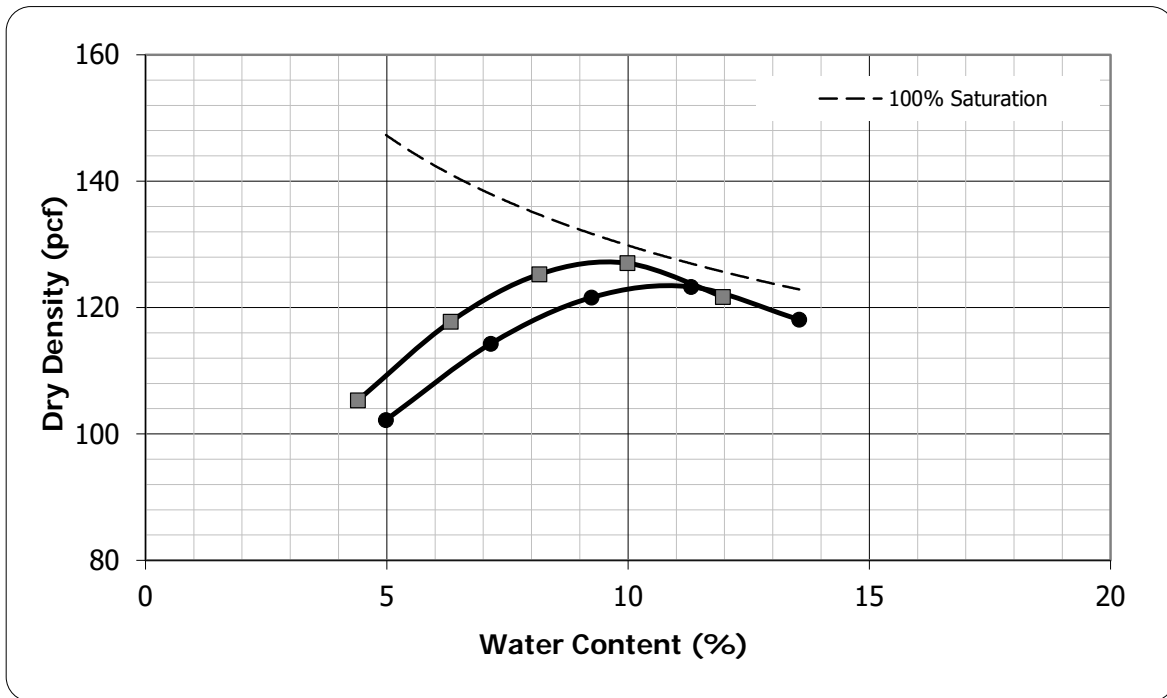

TEST RESULTS		Before Correc.		After Correc.				
Maximum Dry Density (pcf)		124		127		Color		
Optimum Moisture Content (%)		11		9		Brown		
Material	Classification		Nat. Moist. (%)	Sp. G. (Assumed)	LL	PI	% > #4	% < #200
	USCS	AASHTO						
CLAYEY SAND	SC	A-2-6	10.1	2.65	37	20	11.7	30.8

Reviewed by *Lindsay Bartz*

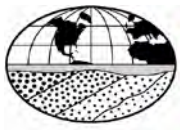

MOISTURE DENSITY RELATIONSHIP - VTM-001			
Project No.	14189	Project Name	Columbia Pike Multimodal St. Improvements
Test Boring No.	CRW-2	Depth (Feet)	0.0'-5.0'
Lab Order No.	3486-13	Date	3/5/2015

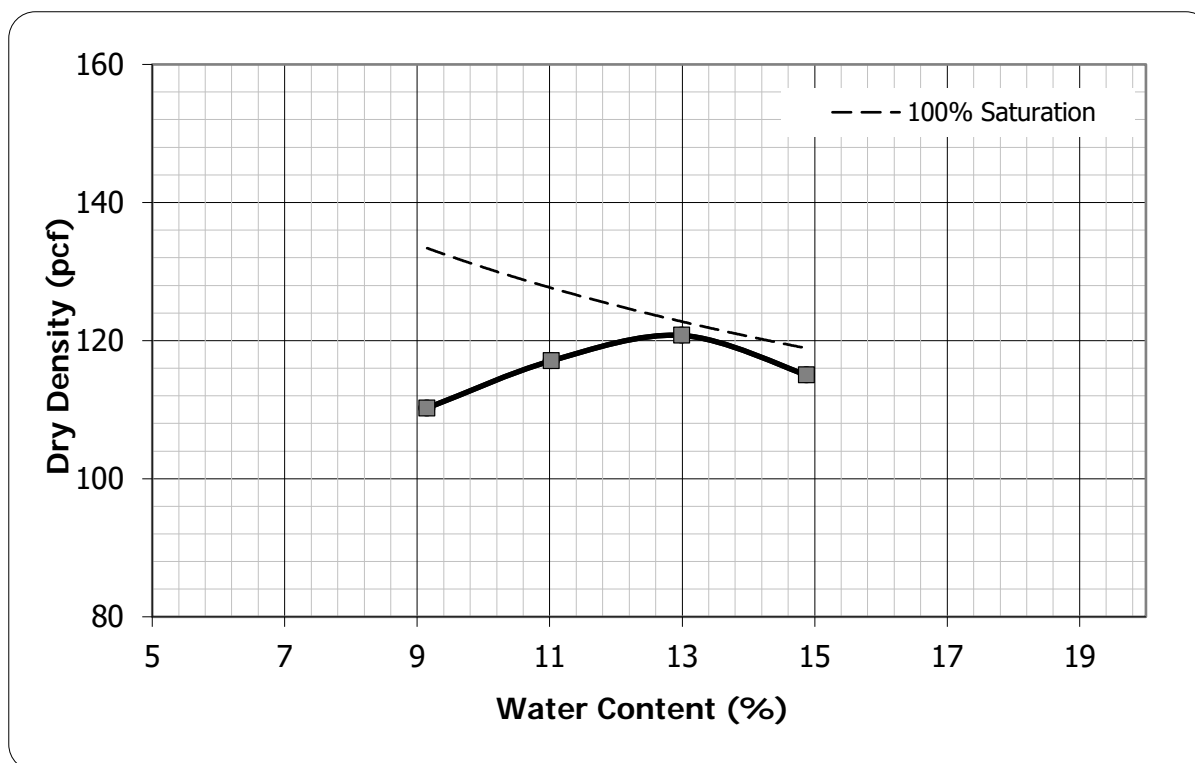

TEST RESULTS		Before Correc.	After Correc.	Color			
Maximum Dry Density (pcf)		121	--	Brown			
Optimum Moisture Content (%)		13	--	Brown			
Material	Classification	Nat. Moist. (%)	Sp. G. (Assumed)	LL	PI	% > # 4	% < # 200
CLAYEY SAND	USCS	14.2	2.65	34	19	9.9	44.9
	AASHTO						

Tested by _____

Reviewed by

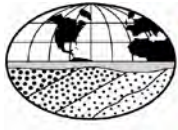

MOISTURE DENSITY RELATIONSHIP - VTM-001			
Project No.	14189	Project Name	Columbia Pike Multimodal St. Improvements
Test Boring No.	CB-5	Depth (Feet)	0.0'-5.0'
Lab Order No.	3486-12	Date	3/5/2015

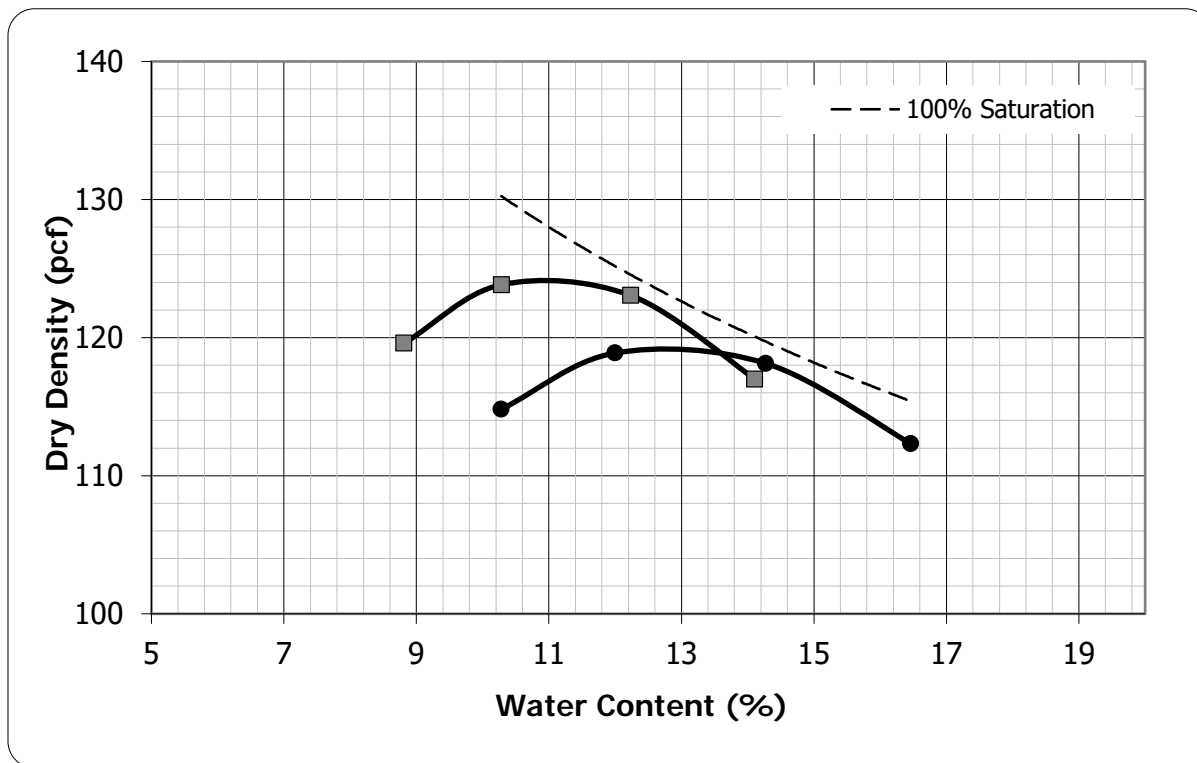

TEST RESULTS		Before Correc.	After Correc.	Color			
Maximum Dry Density (pcf)		119	124	Light Grayish Brown			
Optimum Moisture Content (%)		13	11	Light Grayish Brown			
Material	Classification	Nat. Moist. (%)	Sp. G. (Assumed)	LL	PI	% > # 4	% < #200
sandy Lean Clay	USCS	9.7	2.65	41	23	14.3	59.1
	AASHTO						

Tested by _____

Reviewed by



MOISTURE DENSITY RELATIONSHIP - VTM-001			
Project No.	14189	Project Name	Columbia Pike Street Improvements
Test Boring No.	CB-8	Depth (Feet)	0.0'-5.0'
Lab Order No.	3483-2	Date	3/5/2014

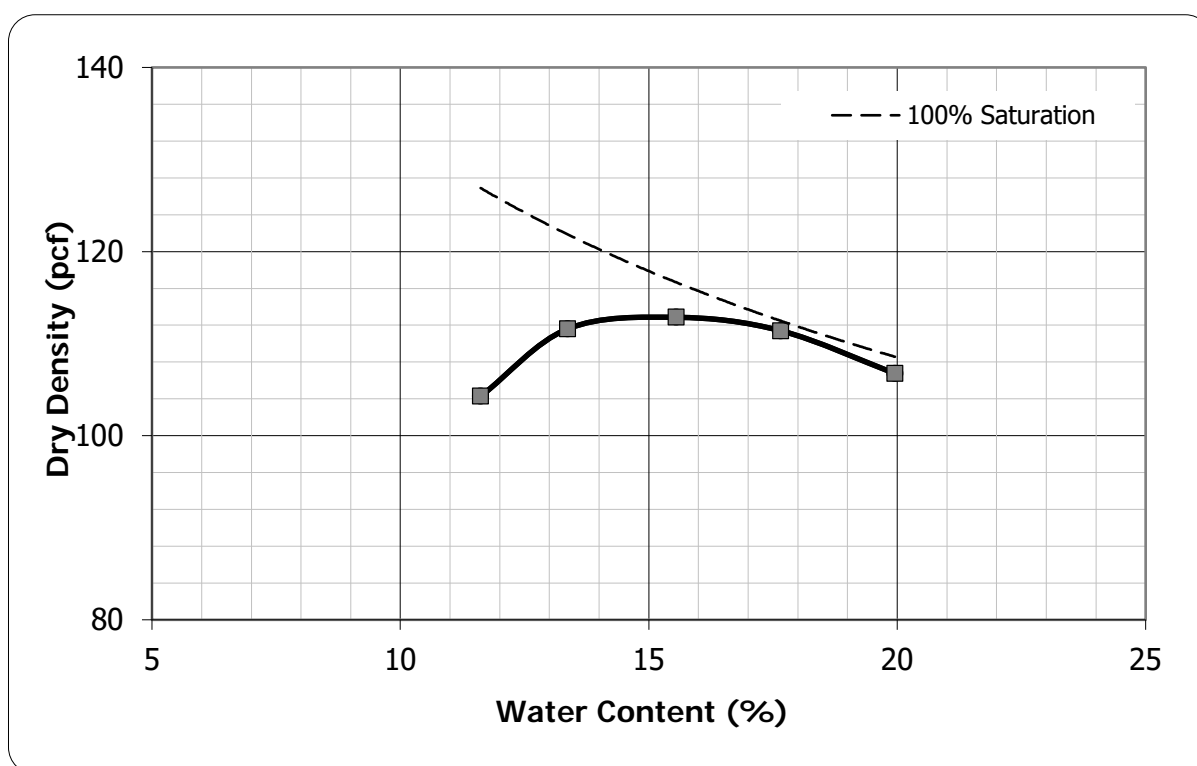

TEST RESULTS	Before Correc.	After Correc.	Color					
Maximum Dry Density (pcf)	113	--	Dark Brownish Gray					
Optimum Moisture Content (%)	15	--	Dark Brownish Gray					
Material	Classification		Nat. Moist. (%)	Sp. G. (Assumed)	LL	PI	% > #4	% < #200
CLAYEY SAND	USCS	AASHTO	16.6	2.65	30	15	5.3	42.1
	SC	A-6						

Tested by _____

Reviewed by



MOISTURE DENSITY RELATIONSHIP - VTM-001			
Project No.	14189	Project Name	Columbia Pike Street Improvements
Test Boring No.	DB-2	Depth (Feet)	0.0'-5.0'
Lab Order No.	3483-1	Date	3/5/2014

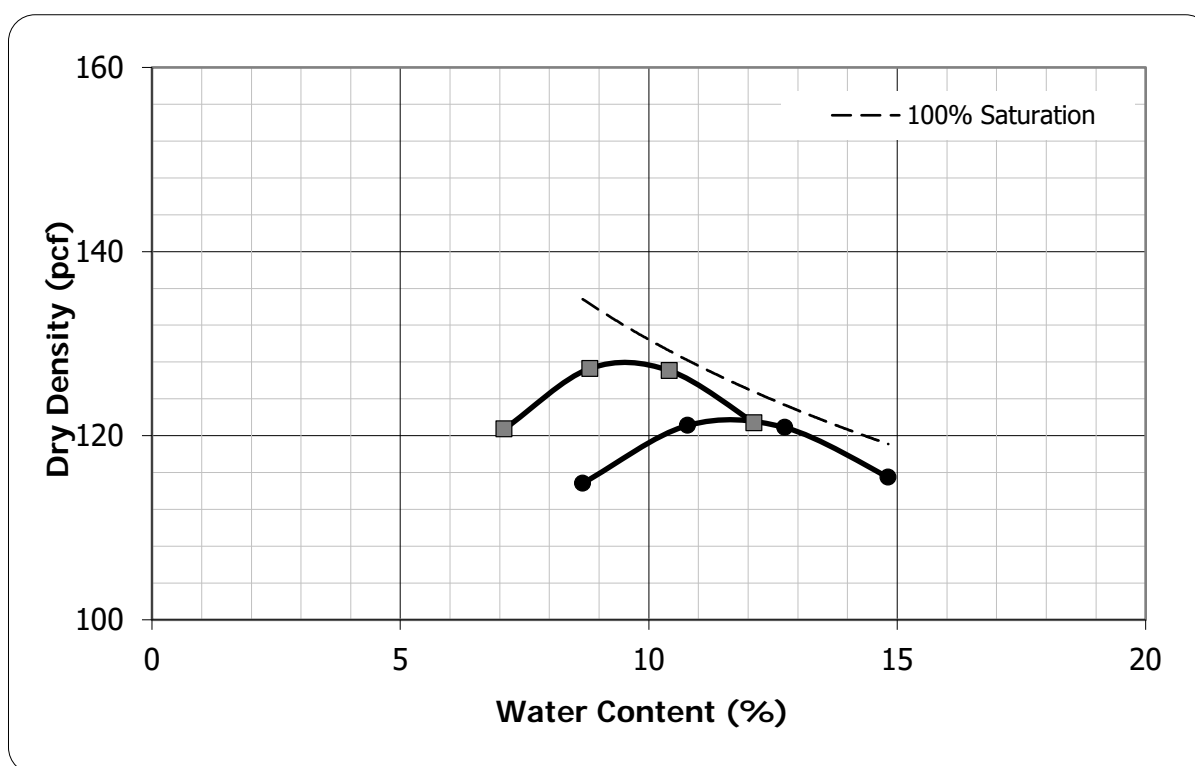

TEST RESULTS	Before Correc.	After Correc.	Color					
Maximum Dry Density (pcf)	121	127	Orange Brown					
Optimum Moisture Content (%)	12	9	Orange Brown					
Material	Classification		Nat. Moist. (%)	Sp. G. (Assumed)	LL	PI	% > #4	% < #200
sandy Fat Clay with gravel	USCS	AASHTO	17.5	2.65	51	30	18.2	61.2
	CH	A-7-6						

Tested by _____

Reviewed by



MOISTURE DENSITY RELATIONSHIP - VTM-001			
Project No.	14189	Project Name	Columbia Pike Multimodal
Test Boring No.	DB-6	Depth (Feet)	0.0'-5.0'
Lab Order No.	3481-2	Date	3/3/2015

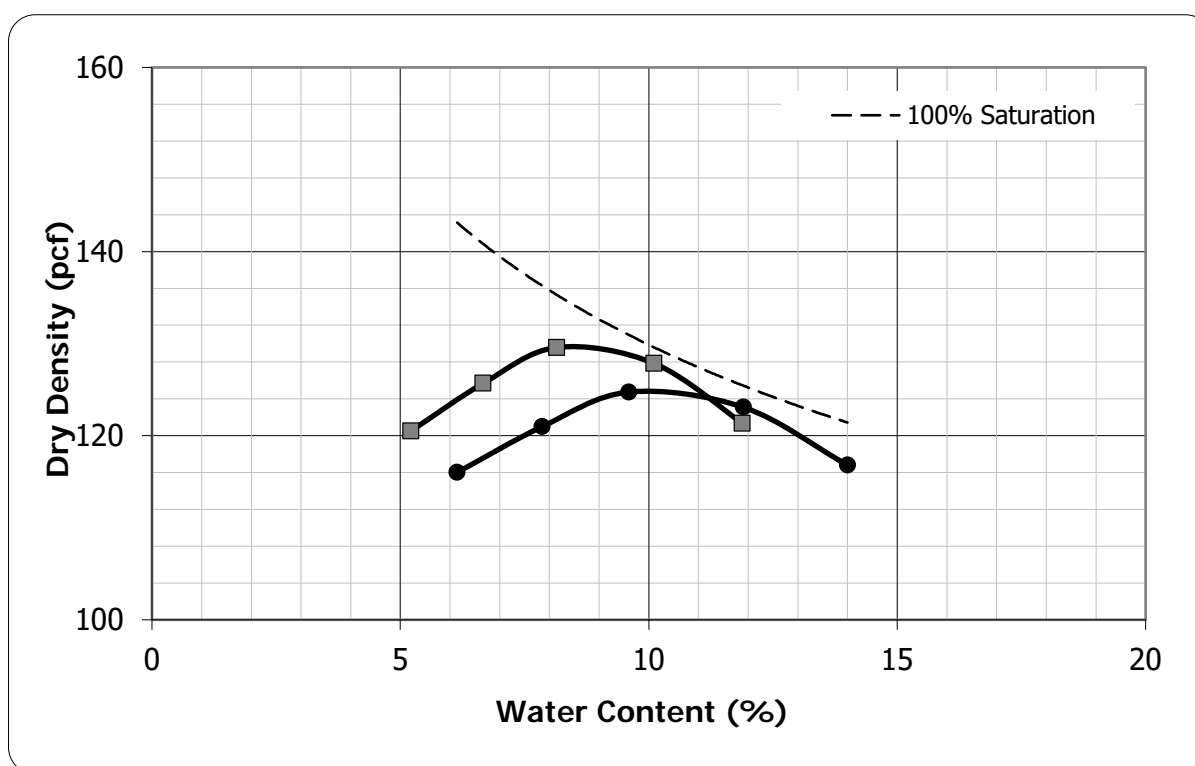

TEST RESULTS	Before Correc.	After Correc.	Color					
Maximum Dry Density (pcf)	125	129	Dark Gray					
Optimum Moisture Content (%)	10	8	Dark Gray					
Material	Classification		Nat. Moist. (%)	Sp. G. (Assumed)	LL	PI	% > #4	% < #200
CLAYEY SAND with gravel	USCS	AASHTO	11.0	2.65	31	16	15.1	32.1
	SC	A-2-6						

Tested by _____

Reviewed by

John Harris



MOISTURE DENSITY RELATIONSHIP - VTM-001			
Project No.	14189	Project Name	Columbia Pike Multimodal
Test Boring No.	DB-10	Depth (Feet)	0.0'-5.0'
Lab Order No.	3481-1	Date	3/3/2015

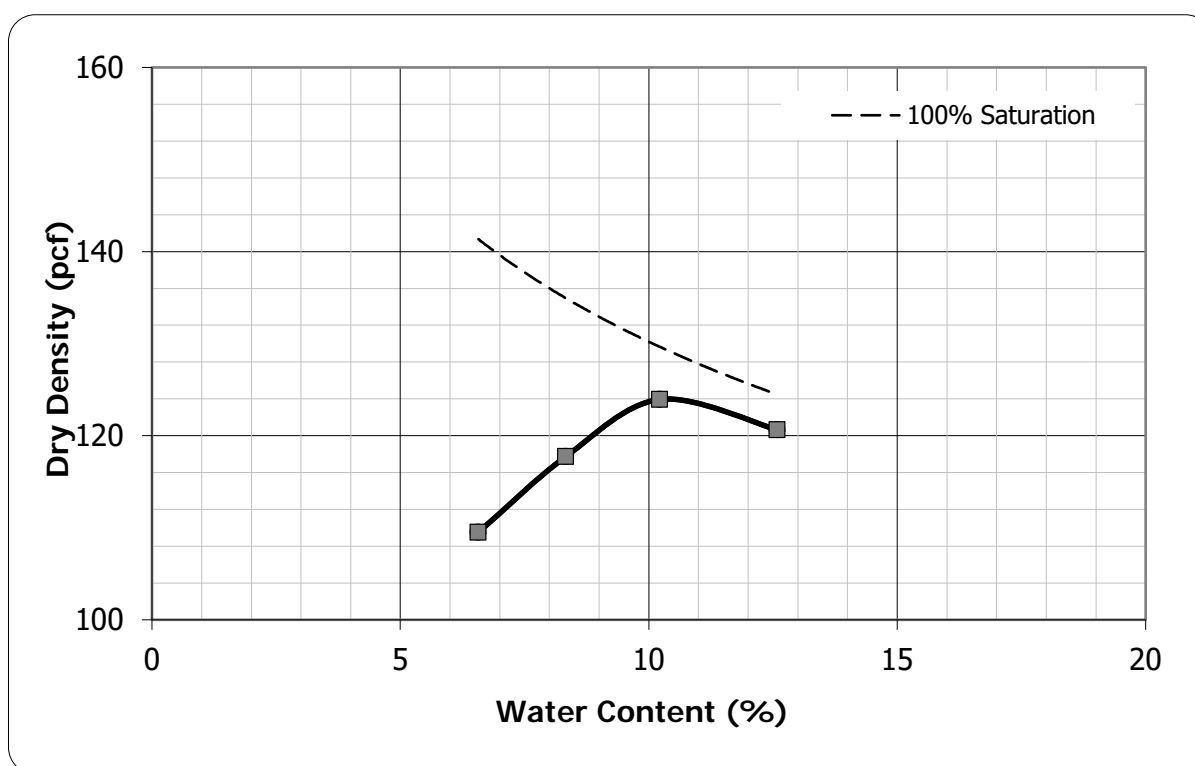

TEST RESULTS	Before Correc.	After Correc.	Color					
Maximum Dry Density (pcf)	124	--	Brownish Gray					
Optimum Moisture Content (%)	10	--	Brownish Gray					
Material	Classification		Nat. Moist. (%)	Sp. G. (Assumed)	LL	PI	% > #4	% < #200
CLAYEY SAND	USCS	AASHTO	16.1	2.65	27	13	2.1	44.4
	SC	A-6						

Tested by _____

Reviewed by

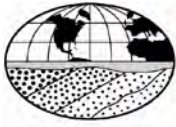

MOISTURE DENSITY RELATIONSHIP - VTM-001			
Project No.	14189	Project Name	Columbia Pike Multimodal St. Improvements
Test Boring No.	FB-2	Depth (Feet)	0.0'-5.0'
Lab Order No.	3480-14	Date	3/6/2015

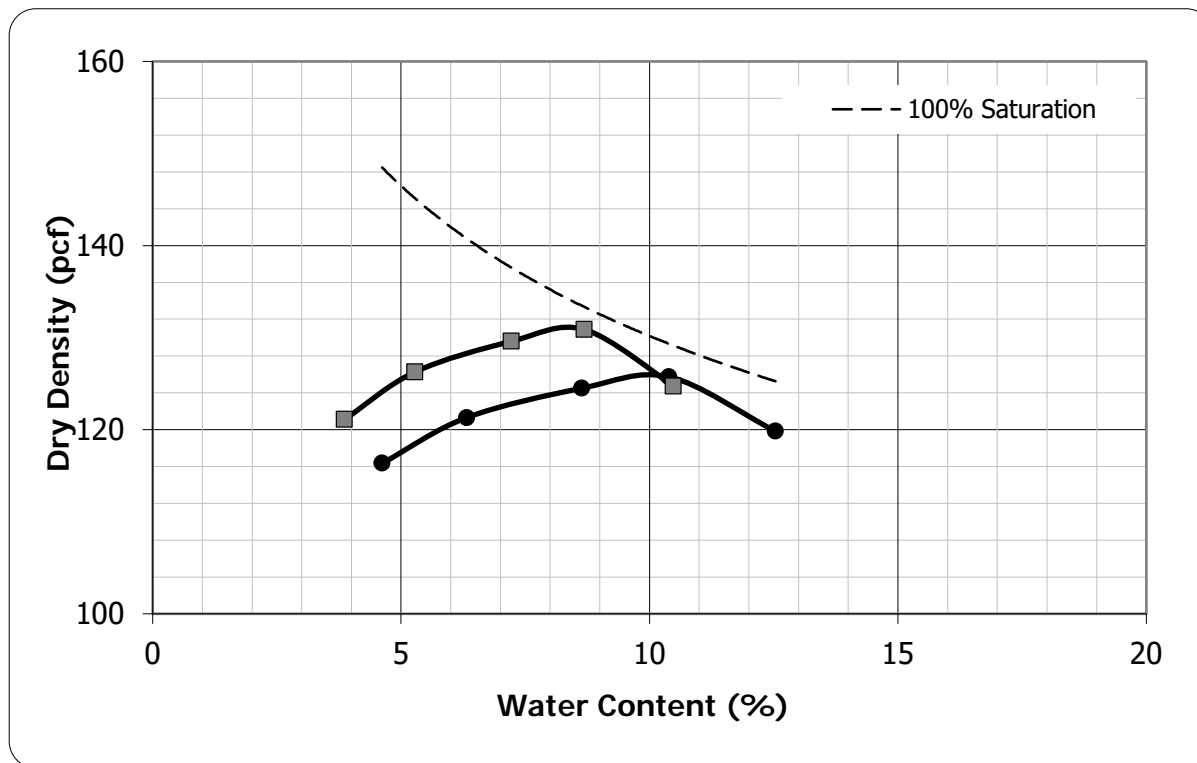

TEST RESULTS		Before Correc.	After Correc.	Color			
Maximum Dry Density (pcf)		126	131	Dark Gray			
Optimum Moisture Content (%)		10	9	Dark Gray			
Material	Classification	Nat. Moist. (%)	Sp. G. (Assumed)	LL	PI	% > # 4	% < # 200
CLAYEY SAND with gravel	USCS	6.2	2.65	72	46	16.4	26.8
	AASHTO						

Tested by _____

Reviewed by

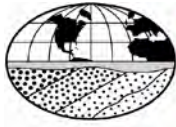

MOISTURE DENSITY RELATIONSHIP - VTM-001			
Project No.	14189	Project Name	Columbia Pike Multimodal St. Improvements
Test Boring No.	FB-9	Depth (Feet)	0.0'-5.0'
Lab Order No.	3480-13	Date	3/6/2015

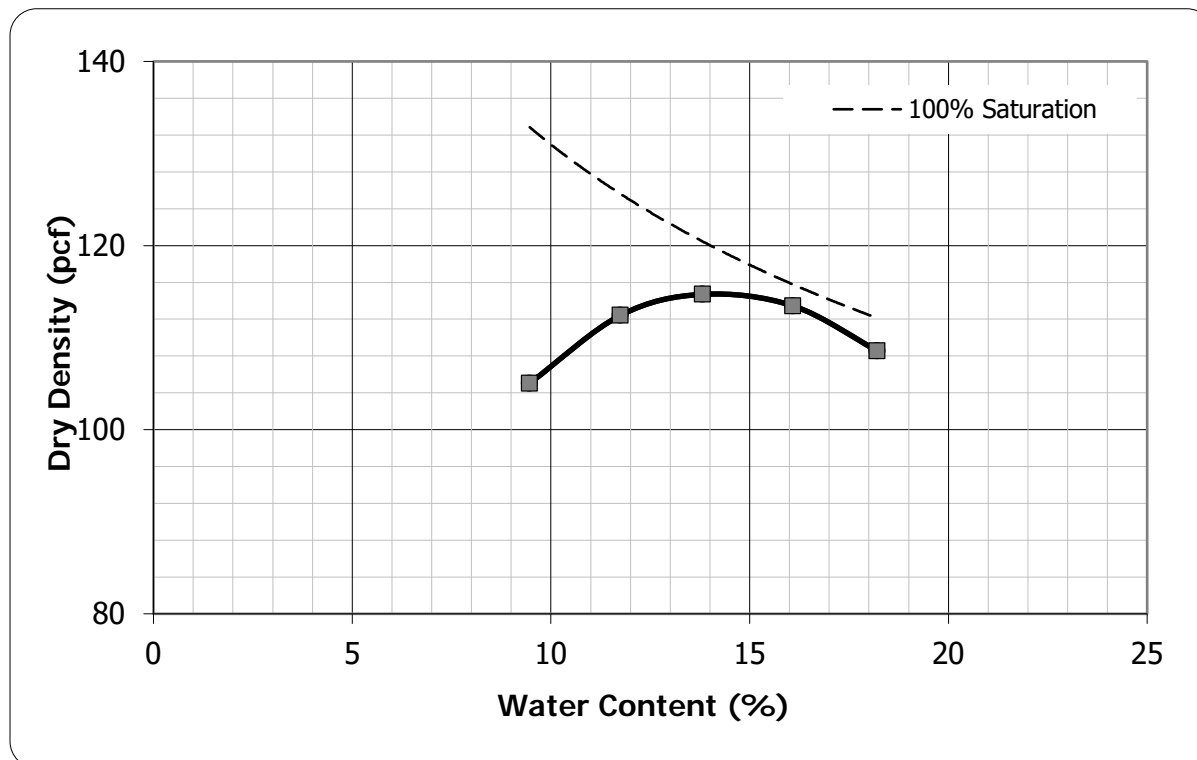

TEST RESULTS		Before Correc.	After Correc.	Color			
Maximum Dry Density (pcf)		115	--	Brownish Gray			
Optimum Moisture Content (%)		14	--				
Material	Classification	Nat. Moist. (%)	Sp. G. (Assumed)	LL	PI	% > # 4	% < # 200
sandy Lean Clay	USCS	14.5	2.65	36	17	8.8	51.1
	AASHTO						

Tested by _____

Reviewed by

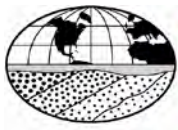

MOISTURE DENSITY RELATIONSHIP - VTM-001			
Project No.	14189	Project Name	Columbia Pike Multimodal St. Improvements
Test Boring No.	FB-18	Depth (Feet)	0.0'-5.0'
Lab Order No.	3480-12	Date	3/6/2015

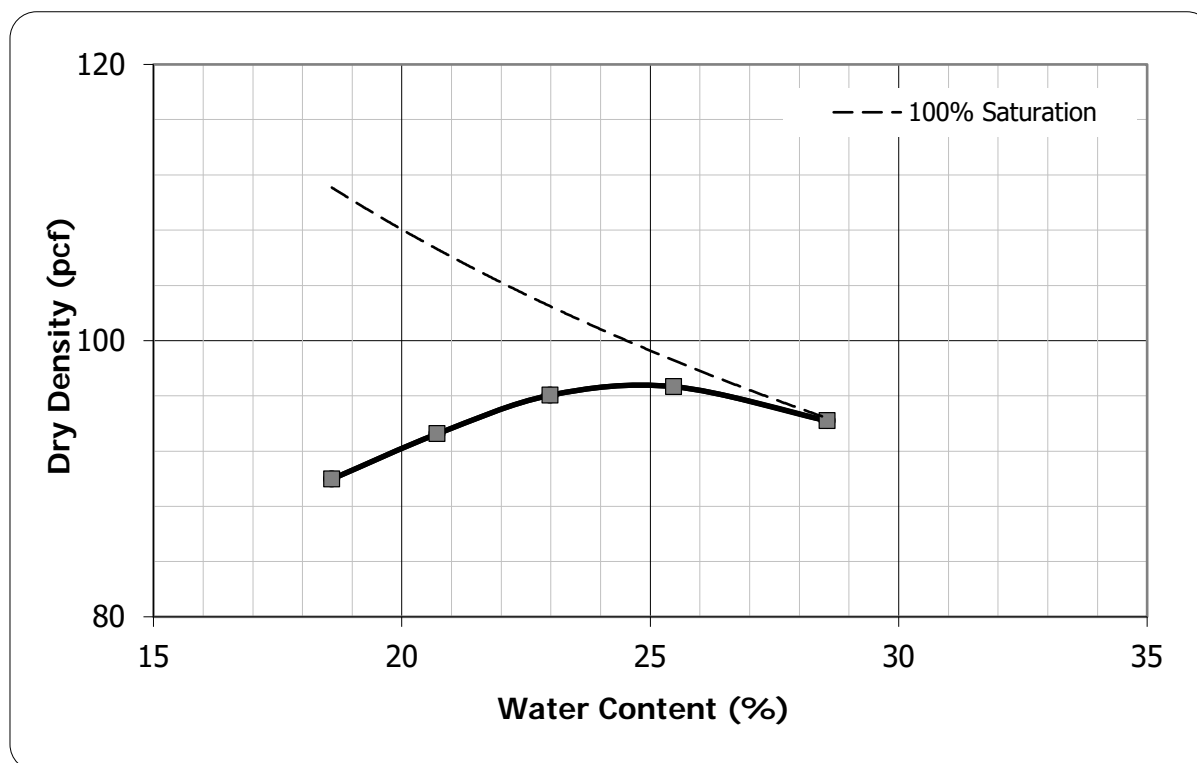

TEST RESULTS		Before Correc.	After Correc.	Color			
Maximum Dry Density (pcf)		97	--	Gray			
Optimum Moisture Content (%)		25	--	Gray			
Material	Classification	Nat. Moist. (%)	Sp. G. (Assumed)	LL	PI	% > # 4	% < #200
Lean Clay	USCS	18.6	2.65	25	8	0.1	86.7
	AASHTO						

Tested by _____

Reviewed by

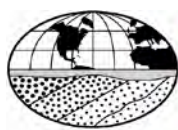

MOISTURE DENSITY RELATIONSHIP - VTM-001			
Project No.	14189	Project Name	Columbia Pike - Segment H/I
Test Boring No.	HB-5	Depth (Feet)	0.0'-5.0'
Lab Order No.	3468	Date	2/5/2015

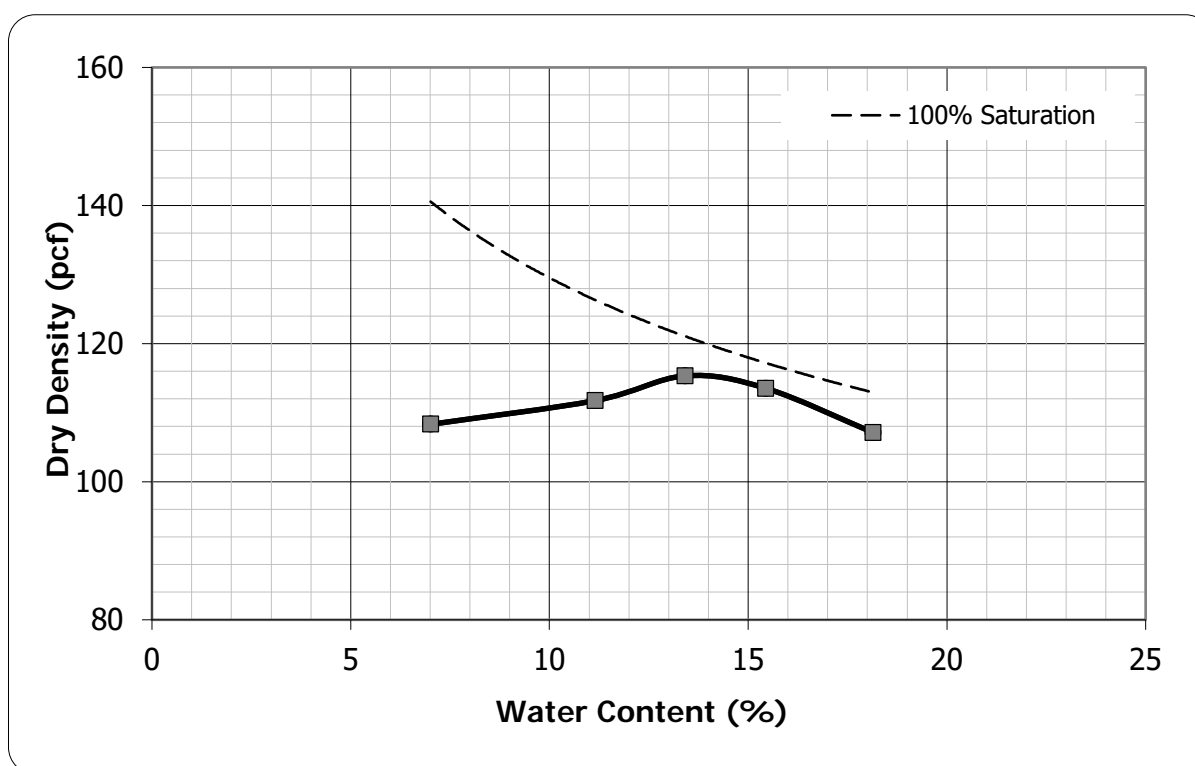

TEST RESULTS	Before Correc.	After Correc.						
Maximum Dry Density (pcf)	115	--	Color					
Optimum Moisture Content (%)	13	--	Gray					
Material	Classification		Nat. Moist. (%)	Sp. G. (Assumed)	LL	PI	% > #4	% < #200
CLAYEY SAND	USCS	AASHTO	17.3	2.65	74	54	5.1	28.6
	SC	A-2-7						

Tested by _____

Reviewed by



MOISTURE DENSITY RELATIONSHIP - VTM-001			
Project No.	14189	Project Name	Columbia Pike Multimodal
Test Boring No.	IB-2	Depth (Feet)	0.0-5.0
Lab Order No.	3462-13	Date	2/2/2015

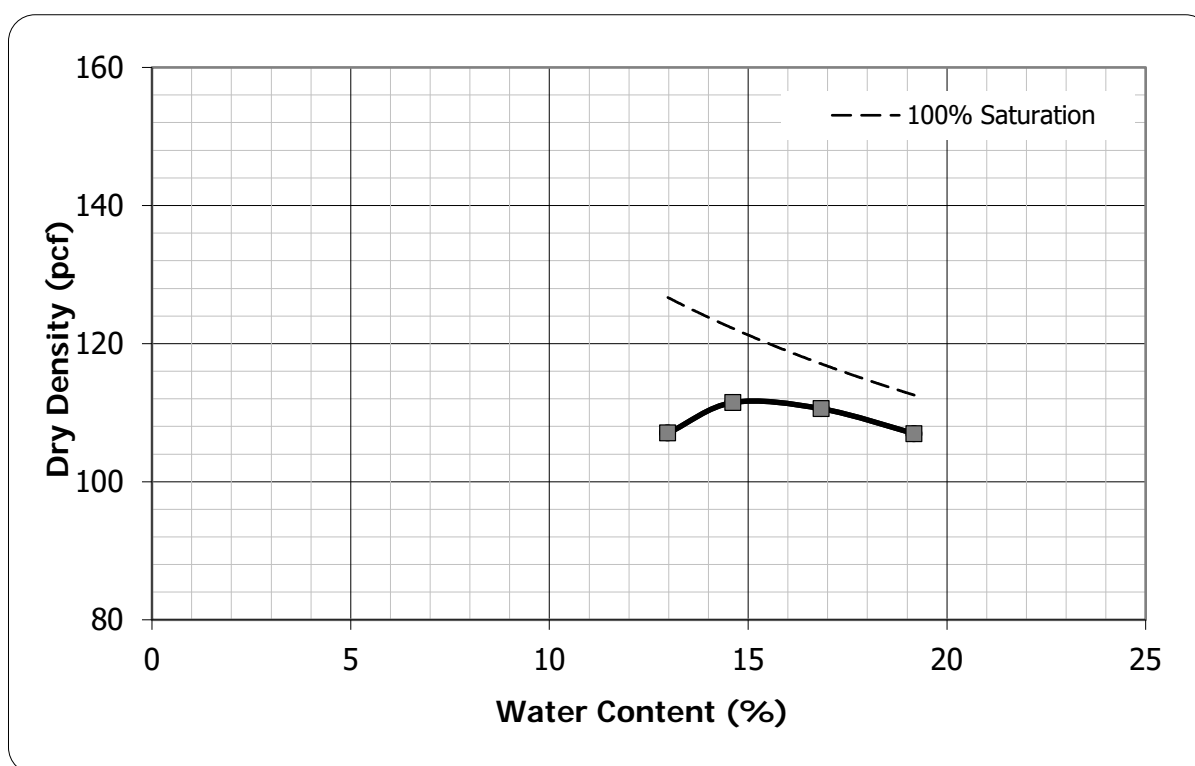

TEST RESULTS	Before Correc.	After Correc.	Color					
Maximum Dry Density (pcf)	112	--	Brownish Gray					
Optimum Moisture Content (%)	15	--	Brownish Gray					
Material	Classification		Nat. Moist. (%)	Sp. G. (Assumed)	LL	PI	% > #4	% < #200
sandy Fat Clay	USCS	AASHTO	24.7	2.75	53	33	1.8	51.0
	CH	A-7-6						

Tested by _____

Reviewed by



MOISTURE DENSITY RELATIONSHIP - VTM-001			
Project No.	14189	Project Name	Columbia Pike Multimodal
Test Boring No.	IB-9	Depth (Feet)	3462-12
Lab Order No.	3462-12	Date	2/2/2015

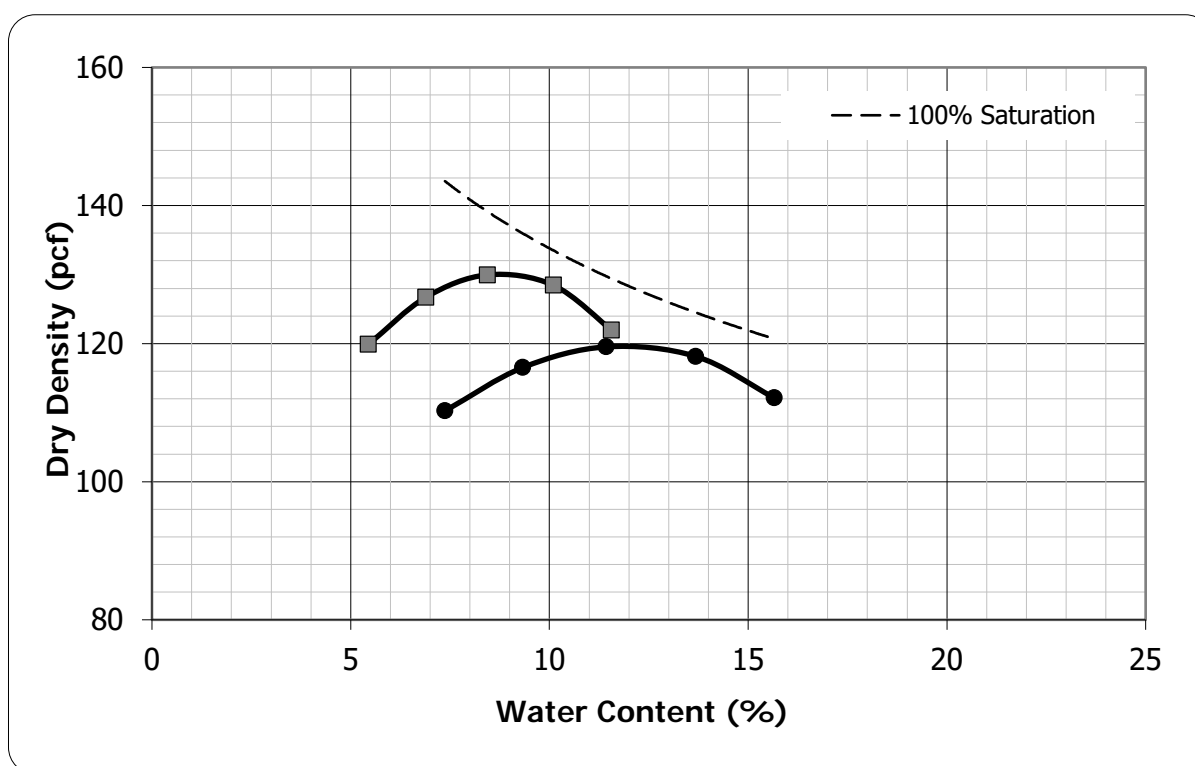

TEST RESULTS	Before Correc.	After Correc.	Color					
Maximum Dry Density (pcf)	119	129	Gray					
Optimum Moisture Content (%)	12	9	Gray					
Material	Classification		Nat. Moist. (%)	Sp. G. (Assumed)	LL	PI	% > #4	% < #200
CLAYEY SAND with gravel	USCS	AASHTO	7.6	2.75	44	29	26.2	31.7
	SC	A-2-7						

Tested by _____

Reviewed by

Appendix C

Pavement Design Calculations

Flexible Pavement Design Calculations (2 pages)

Rigid Pavement Design Calculations (4 pages)

Table C-1: Unsuitable Soil Summary and Recommendations (3 pages)

1993 AASHTO Pavement Design

DARWin Pavement Design and Analysis System

A Proprietary AASHTOWare
Computer Software Product
Microsoft

Flexible Structural Design Module

Columbia Pike Segments A, C, D, and F

Flexible Structural Design

18-kip ESALs Over Initial Performance Period	5,550,524
Initial Serviceability	4.2
Terminal Serviceability	2.8
Reliability Level	90 %
Overall Standard Deviation	0.49
Roadbed Soil Resilient Modulus	5,000 psi
Stage Construction	1
Calculated Design Structural Number	5.61 in

Simple ESAL Calculation

Performance Period (years)	20
Two-Way Traffic (ADT)	31,525
Number of Lanes in Design Direction	2
Percent of All Trucks in Design Lane	90 %
Percent Trucks in Design Direction	50 %
Percent Heavy Trucks (of ADT) FHWA Class 5 or Greater	5 %
Average Initial Truck Factor (ESALs/truck)	1.05
Annual Truck Factor Growth Rate	0 %
Annual Truck Volume Growth Rate	0.21 %
Growth	Compound
Total Calculated Cumulative ESALs	5,550,524

Specified Layer Design

<u>Layer</u>	<u>Material Description</u>	Struct Coef. <u>(Ai)</u>	Drain Coef. <u>(Mi)</u>	Thickness <u>(Di)(in)</u>	Width <u>(ft)</u>	Calculated <u>SN (in)</u>
1	SM-9.5	0.44	1	2	11	0.88
2	BM-25.0	0.44	1	8	11	3.52
3	Graded Aggregate Base 21A	0.12	1	12	11	1.44
Total	-	-	-	22.00	-	5.84

1993 AASHTO Pavement Design

DARWin Pavement Design and Analysis System

A Proprietary AASHTOWare
Computer Software Product
Microsoft

Flexible Structural Design Module

Columbia Pike Segments H&I

Flexible Structural Design

18-kip ESALs Over Initial Performance Period	5,718,512
Initial Serviceability	4.2
Terminal Serviceability	2.8
Reliability Level	90 %
Overall Standard Deviation	0.49
Roadbed Soil Resilient Modulus	5,000 psi
Stage Construction	1
Calculated Design Structural Number	5.64 in

Simple ESAL Calculation

Performance Period (years)	20
Two-Way Traffic (ADT)	31,955
Number of Lanes in Design Direction	2
Percent of All Trucks in Design Lane	90 %
Percent Trucks in Design Direction	50 %
Percent Heavy Trucks (of ADT) FHWA Class 5 or Greater	5 %
Average Initial Truck Factor (ESALs/truck)	1.05
Annual Truck Factor Growth Rate	0 %
Annual Truck Volume Growth Rate	0.38 %
Growth	Compound
Total Calculated Cumulative ESALs	5,718,512

Specified Layer Design

<u>Layer</u>	<u>Material Description</u>	Struct Coef. <u>(Ai)</u>	Drain Coef. <u>(Mi)</u>	Thickness <u>(Di)(in)</u>	Width <u>(ft)</u>	Calculated <u>SN (in)</u>
1	SM-9.5	0.44	1	2	11	0.88
2	BM-25.0	0.44	1	8	11	3.52
3	Graded Aggregate Base 21A	0.12	1	12	11	1.44
Total	-	-	-	22.00	-	5.84

*Note: This value is not represented by the inputs or an error occurred in calculation.

1993 AASHTO Pavement Design

DARWin Pavement Design and Analysis System

A Proprietary AASHTOWare Computer Software Product

Rigid Structural Design Module

Columbia Pike Segments A, C, D, and F

Rigid Structural Design

Pavement Type	JPCP
18-kip ESALs Over Initial Performance Period	12,741,724
Initial Serviceability	4.5
Terminal Serviceability	2.8
28-day Mean PCC Modulus of Rupture	650 psi
28-day Mean Elastic Modulus of Slab	5,000,000 psi
Mean Effective k-value	257 psi/in
Reliability Level	90 %
Overall Standard Deviation	0.39
Load Transfer Coefficient, J	2.7
Overall Drainage Coefficient, Cd	1
Calculated Design Thickness	9.81 in

Simple ESAL Calculation

Performance Period (years)	30
Two-Way Traffic (ADT)	31,525
Number of Lanes in Design Direction	2
Percent of All Trucks in Design Lane	90 %
Percent Trucks in Design Direction	50 %
Percent Heavy Trucks (of ADT) FHWA Class 5 or Greater	5 %
Average Initial Truck Factor (ESALs/truck)	1.59
Annual Truck Factor Growth Rate	0 %
Annual Truck Volume Growth Rate	0.21 %
Growth	Compound
Total Calculated Cumulative ESALs	12,741,724

Layer Information

Joint Spacing	16 ft
Dowel Material	Steel
Dowel Diameter	1 in
Dowel Length	18 in
Dowel Space	12 in
Dowel Coating	Epoxi

<u>Layer</u>	<u>Material Description</u>	Thickness (in)	One Dir Width (ft)
1	JPCP	9.8098206	-

<u>Layer</u>	<u>Material Description</u>	Thickness <u>(in)</u>	One Dir Width <u>(ft)</u>
2	Crushed Aggregate	6	-
3	-	-	-
Total	-	15.81	-

1993 AASHTO Pavement Design

DARWin Pavement Design and Analysis System

A Proprietary AASHTOWare
Computer Software Product

Rigid Structural Design Module

Columbia Pike Segments H&I

Rigid Structural Design

Pavement Type	JPCP
18-kip ESALs Over Initial Performance Period	13,241,836
Initial Serviceability	4.5
Terminal Serviceability	2.8
28-day Mean PCC Modulus of Rupture	650 psi
28-day Mean Elastic Modulus of Slab	5,000,000 psi
Mean Effective k-value	257 psi/in
Reliability Level	90 %
Overall Standard Deviation	0.39
Load Transfer Coefficient, J	2.7
Overall Drainage Coefficient, Cd	1
Calculated Design Thickness	9.87 in

Effective Modulus of Subgrade Reaction

<u>Period</u>	<u>Description</u>	Roadbed Soil Resilient <u>Modulus (psi)</u>	Base Elastic Modulus <u>(psi)</u>
	Base Type	-	
	Base Thickness	- in	
	Depth to Bedrock	- ft	
	Projected Slab Thickness	- in	
	Loss of Support Category	-	
	Effective Modulus of Subgrade Reaction	- psi/in*	

*Note: This value is not represented by the inputs or an error occurred in calculation.

Simple ESAL Calculation

Performance Period (years)	30
Two-Way Traffic (ADT)	31,955
Number of Lanes in Design Direction	2
Percent of All Trucks in Design Lane	90 %
Percent Trucks in Design Direction	50 %
Percent Heavy Trucks (of ADT) FHWA Class 5 or Greater	5 %
Average Initial Truck Factor (ESALs/truck)	1.59
Annual Truck Factor Growth Rate	0 %
Annual Truck Volume Growth Rate	0.38 %
Growth	Compound

Total Calculated Cumulative ESALs

13,241,836

Layer Information

Joint Spacing	16 ft
Dowel Material	Steel
Dowel Diameter	1 in
Dowel Length	18 in
Dowel Space	12 in
Dowel Coating	Epoxi

<u>Layer</u>	<u>Material Description</u>	Thickness <u>(in)</u>	One Dir Width <u>(ft)</u>
1	JPCP	9.8707114	-
2	Crushed Aggregate	6	-
3	-	-	-
Total	-	15.87	-

Table C-1: Unsuitable Soil Summary and Recommendations

Location	Station No.		Representative Boring No.	Unsuitable Soil (ft)			Recommended Treatment below Pavement Subgrade
	From	To		CH/MH OH/OL	Soft or Loose Soil	CBR <5	
Segment A	57+00	58+00	AB-12	--	--	--	No Treatment Required
	58+00	59+75	AB-13	--	--	3.0-5.0	No Treatment Required
	59+75	61+00	AB-14	--	--	3.0-5.0	No Treatment Required
	61+00	62+50	AB-15	--	--	--	No Treatment Required
	62+50	64+00	AB-16	--	--	3.0-7.5	No Treatment Required
Segment C	73+00	74+00	CRW-1	--	--	--	No Treatment Required
	74+00	75+25	CRW-2	--	--	0.0-5.0	B
	75+25	77+00	CB-3	--	--	0.0-5.0	B
	77+00	78+00	CB-4	--	--	0.0-2.5	B
	78+00	81+00	CB-5	--	--	0.0-5.0 8.5-10.0	B
	81+00	83+00	CB-6	--	--	--	No Treatment Required
	83+00	85+50	CB-7	--	--	8.5-10.0	No Treatment Required
	85+50	87+50	CB-8	--	0.0-2.5	2.5-5.0	A
	87+50	89+00	CB-9	--	--	--	No Treatment Required
Segment D	89+00	91+50	DB-1	--	--	0.0-5.0	B
	91+50	94+25	DB-2	0.0-8.5	--	0.0-8.5	B
	94+25	96+50	DB-3	--	--	5.0-8.5	No Treatment Required
	96+50	98+50	DB-4	--	5.0-8.5	5.0-8.5	No Treatment Required
	98+50	100+50	DB-5	--	--	--	No Treatment Required
	100+50	102+75	DB-6	--	0.8-5.0	5.0-10.0	A
	102+75	105+00	DB-7	--	--	8.5-10.0	No Treatment Required
	105+00	107+00	DB-8	--	--	8.5-10.0	No Treatment Required
	107+00	109+00	DB-9	--	--	2.5-5.0 8.5-10.0	No Treatment Required
	109+00	110+50	DB-10	--	--	0.0-2.5	B
	110+50	112+00	DB-11	--	--	0.0-5.0	B

Table C-1: Unsuitable Soil Summary and Recommendations

Location	Station No.		Representative Boring No.	Unsuitable Soil (ft)			Recommended Treatment below Pavement Subgrade
	From	To		CH/MH OH/OL	Soft or Loose Soil	CBR <5	
Segment F	136+00	136+50	FRW-1	13.5-15.0	--	13.5-15.0	No Treatment Required
	136+50	136+75	FB-1	0.0-2.5 8.5-10.0	--	0.0-2.5 8.5-10.0	B
	136+75	137+25	FB-2	13.5-15.0	--	13.5-15.0	No Treatment Required
	137+25	138+00	FRW-2	--	8.5-13.5	--	No Treatment Required
	138+00	138+50	FRW-3	8.5-15.0	8.5-10.0	8.5-10.0	No Treatment Required
	138+50	139+00	FB-3	2.5-5.0 8.5-10.0	--	2.5-5.0 8.5-10.0	No Treatment Required
	139+00	139+75	FRW-4	--	--	5.0-15.0	No Treatment Required
	139+75	140+25	FB-4	--	3.0-4.5	--	No Treatment Required
	140+25	141+00	FRW-5	--	--	13.5-15.0	No Treatment Required
	141+00	141+75	FRW-6	5.0-8.5	--	5.0-8.5	No Treatment Required
	141+75	142+25	FB-5	0.0-10.0	--	0.0-10.0	B
	142+25	142+75	FRW-7	0.0-5.0	--	0.0-5.0	B
	142+75	143+25	FB-6	--	--	--	No Treatment Required
	143+25	144+25	FRW-8	--	--	13.5-15.0	No Treatment Required
	144+25	146+00	FB-7	0.0-8.5	--	0.0-8.5	B
	146+00	147+75	FB-8	0.0-3.5	--	0.0-3.5	B
	147+75	149+25	FB-9	--	--	--	No Treatment Required
	149+25	151+75	FB-10	8.5-10.0	8.5-10.0	8.5-10.0	No Treatment Required
	151+75	154+00	FB-11	0.0-5.0 8.5-10.0	--	0.0-5.0 8.5-10.0	B
	154+00	155+50	FB-12	0.0-2.5	--	0.0-2.5	B
155+50	157+00	FB-13	2.5-10.0	--	2.5-10.0	No Treatment Required	
157+00	159+00	FB-14	8.5-10.0	--	8.5-10.0	No Treatment Required	
159+00	159+75	FB-15	--	--	--	No Treatment Required	
159+75	163+25	FB-17	--	--	--	No Treatment Required	
163+25	165+00	FB-18	--	--	0.0-10.0	B	
165+00	167+00	HA-19	--	--	--	No Treatment Required	

Table C-1: Unsuitable Soil Summary and Recommendations

Location	Station No.		Representative Boring No.	Unsuitable Soil (ft)			Recommended Treatment below Pavement Subgrade
	From	To		CH/MH OH/OL	Soft or Loose Soil	CBR <5	
Segment H	182+00	183+00	HB-2	--	--	--	No Treatment Required
	183+00	186+75	HB-3	--	--	--	No Treatment Required
	186+75	188+50	HB-4	--	--	--	No Treatment Required
	188+50	190+50	HB-5	--	--	--	No Treatment Required
	190+50	192+50	HB-6	--	--	--	No Treatment Required
	192+50	194+00	HB-7	--	--	5.0-10.0	No Treatment Required
Segment I	198+00	195+50	IB-1	--	--	--	No Treatment Required
	195+50	196+00	IRW-4A	--	--	--	No Treatment Required
	196+00	169+50	HA-4	--	--	--	No Treatment Required
	169+50	197+00	IB-2	0.0-8.5	--	0.0-8.5	B
	197+00	198+25	HA-3	--	--	1.5-4.0	B
	198+25	200+20	IB-3	--	--	--	No Treatment Required
	200+20	202+25	IB-4	--	--	--	No Treatment Required
	202+25	204+25	IB-5	--	--	--	No Treatment Required
	204+25	205+25	HA-2	--	--	--	No Treatment Required
	205+25	206+00	IB-6	--	--	--	No Treatment Required
	206+00	207+00	IRW-1	0.0-2.5	0.0-2.5	0.0-2.5	B
	207+00	208+50	IB-7	--	--	--	No Treatment Required
	208+50	209+00	IB-8	--	--	--	No Treatment Required
209+00	212+00	IB-10	--	--	--	No Treatment Required	
S Thomas St.	0+00	3+00	FB-16	--	--	--	No Treatment Required
S Columbus St.	0+00	3+00	HB-1	--	--	--	No Treatment Required
S Jefferson St.	0+00	3+00	IB-9	--	--	--	No Treatment Required

RECOMMENDED TREATMENTS:

- A. Excavate unsuitable materials (soft or loose soils) to a minimum depth of 3 feet below subgrade and allow to dry, prior to re-use as new compacted fill.
- B. Excavate unsuitable materials (CBR<5, CH/MH/OH/OL) to a minimum depth of 3 feet below subgrade and replace with new compacted fill with a minimum CBR value of 5.