



# Robertson County Tennessee

*Jody Stewart, Finance Director*

*Finance Department*

523 South Brown Street, Springfield, TN 37172

(615) 384-0202

Fax (615) 384-0237

POST DATE: **January 15, 2019**

## **BID 1433: SERVING LINE FOR EAST ROBERTSON HIGH SCHOOL**

Sealed bids must be received by: February 19, 2020 at 10:00 AM

Robertson County Finance Office

523 South Brown Street

Springfield, TN 37172

**THE OUTSIDE OF THE ENVELOPE MUST BE MARKED WITH THE BIDDER'S COMPANY NAME, ITEM BID, TIME OF BID OPENING, DATE OF BID OPENING, BID NO. 1433 AND MUST BE MARKED "SEALED BID, DO NOT OPEN."**

Bids are opened and read aloud to the public at the Robertson County Finance Office, 523 S. Brown Street, Springfield, TN 37172 immediately after the bid receipt deadline. Each vendor may submit more than one bid provided each bid meets the stated specifications. Each bid must be submitted in a separate sealed envelope with the appropriate notation on the outside. All bids must be signed by an authorized agent and submitted on the prescribed forms. Submission of bids by telegraph, telephone, or other electronic means is strictly prohibited. Any brand name called for the bid specifications is provided as a reference only. Alternate brand name items offered for bid must be equivalent as to function, basic design, type and quality of material, method of construction, and any required dimensions. Bidder must attach a letter of exception to specifications.

For assistance with technical / product information contact Patsi Gregory, Supervisor, School Nutrition at (615) 384-5588. For assistance with bid procedures contact Taylor Tomblin, Robertson County Finance Office at (615) 384-0202 or by email: [ttomblin@robcotn.org](mailto:ttomblin@robcotn.org).

**Note: Robertson County reserves the right to reject any or all bids, to waive any technicalities or informalities, and to accept any bid deemed in the best interest of the County. All bids will be considered in accordance with Title VI and without regard to age, sex, color, race, creed, national origin, religious persuasion, marital status, political belief, or disability that does not prohibit the performance of duty.**

Robertson County Board of Education  
800 M.S. Coutts Boulevard  
Springfield, TN 37172  
January 13, 2020

The scope of this Invitation for Bid includes the purchase and installation of a commercial serving line at East Robertson High School cafeteria kitchen for the School Nutrition Program in the Robertson County School District. The school is located at 158 Kilgore Trace Cross Plains, TN 37049. The district intends to purchase this equipment from the most responsible and responsive vendor that will meet the specifications. Bidders are strongly encouraged to enter into purchase agreements with local producers and supply those local products on the school nutrition bid.

Robertson County Board of Education has approximately 11,500 students enrolled. The Robertson County School Nutrition Program served a total of 2,057,866 breakfast and lunch meals in the 2018-2019 School Year.

Robertson County Board of Education is requesting your firm's participation in our bid for the products and services rendered. Robertson County is interested in:

1. Selecting suppliers in such a manner as to provide for open and free competition and comparability.
2. Creating strong partnerships with the suppliers of goods and services.
3. Taking advantage of economies of scale to help reduce costs.
4. Equipping kitchens across the Robertson County School District with similar equipment.

Robertson County will award this bid on a bottom line all or nothing basis, based upon one (1) serving line for East Robertson High School. The Robertson County School Nutrition Program will be responsible for payment of all purchases and services rendered.

If there are any questions regarding this solicitation, please call Patsi Gregory at (615) 384-5588.

Again, we thank you for your interest and participation in this bid.

For purposes of this bid, all references to Robertson County Schools, Robertson County Board of Education, Robertson County, County, Schools, Board, School Nutrition Program, and SNP are interchangeable in this document.

**Equipment Purchase and Installation**  
**Please fill out for each serving line bid**

COMPANY: \_\_\_\_\_

THE UNDERSIGNED HEREBY PROPOSES AND AGREES TO FURNISH AND DELIVER THE GOODS OR SERVICES IN ACCORDANCE WITH THE TERMS, CONDITIONS, SPECIFICATIONS AND PRICES HEREIN QUOTED.

COMPANY NAME: \_\_\_\_\_ PHONE: \_\_\_\_\_

ADDRESS: \_\_\_\_\_ CITY: \_\_\_\_\_

STATE: \_\_\_\_\_ ZIP: \_\_\_\_\_

BY: \_\_\_\_\_

SIGNATURE IN INK

PRINTED OR TYPEWRITTEN NAME

TITLE/POSITION: \_\_\_\_\_

REPRESENTATIVE

REPRESENTATIVE EMAIL ADDRESS: \_\_\_\_\_

**BID IS NOT ACCEPTABLE UNLESS SIGNED BY AUTHORIZED OFFICER.**

**DO NOT USE PENCIL – CORRECTIONS MUST BE INITIALED.**

**All forms, General and Specific Bid Conditions must be enclosed in a sealed envelope. The envelope must be identified with the appropriate information as directed in the bid cover page. Bidder's Company Name, Item Bid, Time of Opening, Date of Opening, Bid Number and include the phrase "Sealed Bid, Do Not Open".**

**Bids cannot be accepted via fax or any other electronic means.**

ROBERTSON COUNTY BOARD OF EDUCATION  
800 M.S. Courts Boulevard  
Springfield, TN 37172

January 13, 2020

GENERAL BID CONDITIONS

I. BIDS

1. The Board of Education proposes to retain Vendor(s) for the purchasing and installation of a serving line at specified School Nutrition Program kitchens in Robertson County, Tennessee (Exhibit A).
2. The bid must be enclosed in a sealed envelope marked appropriately as directed in the bid cover page.
3. The objective of this invitation to bid is to select the most responsive and responsible vendor for the items requested in this bid. This bid is being requested this way to determine the best supplier for the piece of equipment to meet the needs requested in this bid document. **This will be bottom line all or nothing award.**

The bid award will ensure that Robertson County is included and serviced as set forth in all general and specific bid conditions.

Any additional materials offered by the vendor to be included in the bid submission must be approved by the designated contact person prior to the bid opening. The vendor could be determined as non-responsive if items are presented that attempt to alter the bid conditions in any way. It is recommended that no additional written documents be included in the bid packet. Please submit only those items that are requested.

The original document cannot be changed **IN FORMAT OR SERVICES REQUESTED.**

If an error is made in quoting the price, or items are not available after the bids are opened, Robertson County reserves the right to award the contract to the next qualified vendor. If the awarded vendor cannot supply a service, the designated contact person MUST be notified before a substitution is made. Substitutions will not be accepted unless authorized. Any service provided that was not authorized will be at the vendor's expense and proper credit issued to the school where services were rendered.

Authorization for the bid must be signed by the bidder on the enclosed "Agreement Form" giving the full name and business address of the company. The person signing the bid must state his/her title and, if requested, show proof of his authority to bind his company by bid. Bids and authorizations must be written in ink or typed.

Robertson County reserves the right to accept or reject any and/or all bids in whole, or in part, if it is deemed to be in the best interest of the County.

Should a bidder find discrepancies or omissions from the bidding document, or should he/she be in doubt as to their omissions, he/she shall at once request clarification from the contact person listed in the Invitation for Bid document.

Do not include Federal or State sales tax in the bids. If a tax exemption certificate is required, please state it on the bid and the appropriate certificate will be furnished to the successful bidder.

All bidders will be notified of the official decision by mail prior to the award starting date.

## II. SITE INSPECTION

Bidders shall visit the site and familiarize themselves with any conditions which may affect performance and bid prices. Submission of a bid will be prima facie evidence that the bidder has made site inspections and is aware of all conditions affecting performance and pricing. East Robertson High School is located at 158 Kilgore Trace Cross Plains, TN 37049. To set up a site visit, please contact Patsi Gregory at (615) 384-5588 or patsi.gregory@rcstn.net

## III. BID RESPONSE AND PRICING

Complete and submit the attached **Bid Response Form** (Exhibit A). This form must be typed or legibly handwritten in ink. The serving line shall be priced per each, delivered to specified school, uncrated, assembled, installed and made operational, and all packing materials removed from the site. For the purpose of bid evaluation, no substitutions will be allowed. Any changes will result in bidder disqualification.

Errors discovered after public opening cannot be corrected, and bidder will be bound to honor the bid for the initial contract period if offered.

Price readjustments of bid quotations are not permitted during the contract period.

All bids shall be in accordance with the instructions to bidders and specifications as attached. Specifications are intended to be open and non-restrictive. A copy of the cut sheets shall be included with the bid packet. If all sheets are not sent with the original bid packet the bid will be non-responsive. Please read entire bid specifications, all bid items must match the bid specs.

The name of a certain brand, make, manufacturer, or definite specifications is to denote the quality to the specific brand, make, manufacturer or specifications named. It is to set forth to convey to prospective bidders the general style, type, character and quality of article desired and should be regarded merely as a standard. Any other brand, make of material, device or equipment which is regarded the equal of that specified, considering quality, workmanship, and economy of operation and is suitable for the purpose intended, shall be prior approved if specified. Please note the attached drawings are for reference only.

**With respect to acceptance of products, SNP shall be the sole judge of compliance with the intent of the specifications.**

The Board of Education may make such investigations as are deemed necessary to determine the ability of the bidder to provide the purchase and installation of the equipment and the bidder shall furnish all such information and data for this purpose as may be requested. The Board reserves the right to reject any proposal if the evidence submitted by our investigation fails to satisfy the Board that the bidder is properly qualified to carry out the obligations of the contract and to complete the work contemplated therein.

#### IV. QUALIFICATIONS OF BIDDERS:

It is required that all fabricated equipment such as food serving units, tables, sinks, counter tops, etc., described in following specifications other than by name and catalog numbers, be manufactured by an equipment fabricator who has the plant, personnel and engineering facilities to properly design, detail and manufacture high quality food service equipment. The manufacturer to be subject to approval of the Owner. All work in the above category must be manufactured by one manufacturer and of standard unit assembly and uniform design and finish.

The manufacturer of this equipment must be able to show that he is now and has been engaged in the manufacture or distribution of equipment as required under this contract as his principal product.

Upon demand, manufacturer being considered for possible negotiation, shall submit to the Owner, evidence of his having executed contracts of a size comparable to this contract. He shall further submit evidence of ample financial resources which enable him to handle the work in a satisfactory manner, and to deliver items of equipment as required, without delaying the progress of the work. The manufacturer of this equipment as herein specified must be a recognized distributor for the items of equipment specified herein.

Quality Assurance:

1. Manufacturer's Qualifications: Firms regularly engaged in manufacture of food service equipment types, capacities, and sizes required, whose products have been satisfactory use in similar service for not less than 5 years.
2. Installer's Qualifications: Firms with at least 3 years of successful installation experience on projects with food service equipment similar to that required for project.
3. Fabricator's Qualifications: Where indicated units required custom fabrication, provide units fabricated by shop which is skilled and with a minimum of 5 years of experience in similar work. Fabricate all custom equipment items at same shop. Where units cannot be fully shop-fabricated, it will be acceptable to complete fabrication work at project site.

Only manufacturers who can meet the foregoing qualifications will be considered to be approved.

#### V. BRANDS AND NAMES:

Substitutions by any bidder wishing to supply alternate equipment other than that specified shall follow the requirements listed in the Invitation to Bid.

Bidders recommending such substitutions are cautioned to examine mechanical and electrical plans and conditions of building to determine if such substitutions will require changes in mechanical or electrical connections which have already been planned. If proposed substitutions require such changes, bidder shall be responsible for any cost involved.

Any FOOD SERVICE CONTRACTOR (manufacturer representatives are not allowed to contact the owner after the bid is released) wishing to supply alternate equipment other than that specified must submit a written request for substitution to the OWNER fifteen (15) days prior to the Bid Date for approval or disapproval. The request must be accompanied by the name of the manufacturer and model, a complete description of the proposed substitution, drawings, catalog cuts, specifications, performance and test data, samples, of applicable, and all information necessary for an evaluation. A statement describing any changes in materials, equipment, or work that incorporation of the substitute would require must be included. A detailed description of the manner in which the

proposed substitution conforms and/or varies from the item specified must also be provided. References of five comparable jobs will be required within a one hundred fifty mile radius of the school. If approved an addendum will be issued.

## VI. **BID AWARD**

Consideration will be given to all bids properly submitted. Bids will receive appropriate confidentiality before awarding. Upon award, bid documents and tabulations will be available for review. Errors discovered after public opening cannot be corrected, and the bidder will be bound to honor bid as submitted.

Robertson County will award the bid to the most responsive and responsible vendor based on the **LOWEST overall price. After meeting all general and specific bid conditions as a qualified vendor, PRICE is the sole determination for the award of the bid.** In calculating total cost per item both the cost of the equipment and the installation cost, if any, will be combined for comparison purposes.

Repair Parts and Maintenance Manuals: When an award is made, the Vendor shall furnish three (3) repair parts and maintenance manuals for each piece of equipment.

Warranty: The Vendor warrants the equipment furnished to be new and free from all defects whatsoever in the materials and workmanship and agrees that for a period of time as specified under each item on the Pricing Schedule from the date of delivery, any repairs, replacements or adjustments made necessary because of any such defect will be made promptly without cost to and to the satisfaction of the owner.

The successful vendor shall guarantee all equipment for a period of at least **three (3) years** from the date of installation. Compressors in refrigerated equipment shall be guaranteed for a period of at least five (5) years from the date of installation. Other warranties should be noted within each piece of equipment specifications. These warranties include parts and labor. If at any time within the warranty period items are found to be faulty, due to poor workmanship or defective materials, the successful vendor shall replace or repair each defective part to the complete satisfaction of SNP and at no cost. If within the first year of operation, after three (3) service calls, any piece of equipment is still found to be defective or deficient it shall be replaced with a new identical unit, or removed at Vendor's expense and the cost refunded to the school district whichever the school district chooses.

Training of staff: The successful vendor will have manufacturer's representatives demonstrate the use, care, minor adjustments and maintenance of equipment to kitchen personnel at the site. During the demonstration, the successful vendor will provide names and telephone numbers to call in the event of equipment failure during the warranty period to the Cafeteria Manager, School Nutrition Program Office and the Robertson County School Building and Grounds Department. Said training will be at a time mutually convenient to both SNP and Vendor.

Extended Warranty: The Vendor shall furnish information regarding extended warranties. SNP reserves the right to accept or reject any additional warranties. The addition or lack of proposed extended warranty shall not be included in the determination of bid award.

## **VII. TERMS AND CONDITIONS OF PAYMENT**

### **ORDERS AND DELIVERY**

- 1) The School Nutrition Program Supervisor will contact the successful vendor to make arrangements for ordering, delivery and installation of each piece of equipment. Pre-numbered purchase orders with firm fixed prices will be used for the purchase of all equipment. Only purchases made with School Nutrition Program purchase orders are allowed on School Nutrition Program accounts.
- 2) Shipments must be made as products are received by awarded company.
- 3) Final installation must be completed for payment to be issued by June 30, 2020.
- 4) Equipment must be delivered inside the kitchen area. The Supervisor or designee will check the items delivered against the purchase order and invoice at the time of delivery with both the Supervisor/designee and driver signing the appropriate forms for errors, and/or obviously damaged goods.
- 5) All equipment is to be delivered with no evidence of damage. The successful bidder agrees to be responsible for damaged packaging and to pick up and replace any products that are damaged.
- 6) The Supervisor or designee shall retain the right to reject any or all a delivery that does not meet product specifications. Rejected items are to be picked up at the supplier's expense and a credit memo issued.
- 7) The awarded company must deliver, uncrate, and set in place the new equipment. They must remove and dispose of all cartons and debris. They must interlock all pieces together. Start-up of all installed equipment shall be required to check for perfect working order.
- 8) Robertson County Schools will remove all existing equipment and will have the proper electrical in place.

## **VIII. INVOICES / STATEMENTS REQUIRED FOR PAYMENT**

All statements are to be issued to include and end with the cut-off date which will be the last day of the month. Two (2) invoices must be furnished to the school at the time of delivery. Invoices must be signed by the Supervisor or designee, show purchase order number, quantity, price of each item delivered and total amount of the order. Unsigned invoices will not be paid. If an item must be returned or rejected, the invoice must be signed by the Supervisor or designee and the person delivering.

At the end of each month, a separate statement showing invoice numbers and dates of delivery to the school must be mailed to School Nutrition Program, 800 M.S. Coats Boulevard, Suite 1, Springfield, TN 37172. Invoices will be balanced with the statement and processed for payment. Statement must include any credits issued during the month. The school serviced under this contract is tax exempt.

## **IX. PROTEST**

If a prospective vendor does not agree with the bid award, they have the right to protest. Disputes arising from the award of this bid must be submitted in writing to Jody Stewart, Robertson County Finance Director, hearing official, no later than ten (10) days from the published award. The hearing official will disclose the dispute to the Tennessee State Department of Education, School Nutrition Office and the Director of Schools. The steps for dispute resolution are as follows:

1. A meeting with the Director of Schools, School Nutrition Program Supervisor, the hearing official and representatives from the disputing party to discuss and resolve the complaint.
2. A written decision letter stating the reasons for the decision will be prepared by the hearing official and submitted in writing to the protestor and all parties involved. This decision letter will



be mailed to the protestor and will advise the protestor that he/she has a right to an additional review.

3. All employees will be notified that they cannot purchase under this procurement until a final decision is rendered.
4. In the event that purchases must be made for the district before a final decision is rendered, the emergency purchase procedures established by the district will be used.

**X. VENDOR PERFORMANCE & RESPONSIBILITIES**

The Vendor shall be an independent contractor and shall retain control over its employees and agents. The Vendor shall be responsible for the safety of their employees. Protective clothing and equipment shall be used when required. OSHA standards shall be expected and enforced at all times.

The Vendor shall provide employees and agents servicing this contract with clearly visible identification, which includes the employee's name, a clear image of the employee's face, and the Company's name.

The execution of services shall be conducted in such a manner as to avoid creating any nuisance for the facility, staff or students.

Vendor shall provide sufficient and qualified managers to supervise performance of the service. The Vendor shall be responsible for any claims, liabilities and expenses related to or arising out of its responsibilities set forth herein. Any contractor found to be using workers who are in the U.S. illegally shall be in violation of this contract.

Vendors with a poor performance history will be notified at the time of such performance and will be given an opportunity to correct any problems. Documentation will be kept on file. Any vendor with continued poor performance during the contract period will be removed from the potential vendor list for one bid period.

Any one and/or a combination of the following penalties will result from the vendor's failure to perform according to contract:

1. Termination of contract
2. Suspension from future bidding (for one bid period)
3. Legal action and civil penalties

**XI. INSURANCE & LICENSES**

Successful Vendor shall have all applicable licensure in good standing to own, operate and provide services in the State of Tennessee and Robertson County. During the term of the Agreement, Vendor shall maintain for protection of the Board of Education and Vendor, Comprehensive or Commercial General Bodily Injury and Property Damage Liability Insurance with a Combined Single Limit of not less than One Million Dollars (\$1,000,000) for each occurrence, including, but not limited to, Personal Injury Liability, Blanket Contractual Liability and Products Liability, covering the operations and activities of the Vendor under this Agreement and shall provide the Board of Education with a certificate evidencing such policies.

The liability insurance coverage shall be considered as primary and not as excess insurance. Robertson County shall be named "Additional Insured" under Vendor's policies of insurance to the extent the County is indemnified pursuant to this Agreement. The insurance policies shall contain covenants by the issuing carrier(s) and shall provide thirty-day written notice to the County by registered mail prior to any modification, cancellation, non-renewal or other change in coverage. All Policies must be effective prior to the commencement of work and must remain in force until termination of work under this contract. Failure to name Robertson County to the carrier for notification of the listed changes described above will result in the termination of the contract.

In the event of interruption of coverage for any reason, all work under the contract shall cease and shall not resume until coverage has been restored. If at any time during the term of this contract or any extension thereof, any required policies of insurance should expire, or are canceled, it will be the responsibility of the contractor to furnish the County a Certificate of Insurance indicating renewal or an acceptable replacement of the expiring policy prior to the expiration or cancellation date so that there will be no lapse in coverage.

The minimum insurance coverage requirements are:

- A. Workers' Compensation Insurance - with a minimum limit of \$1,000,000.00 each occurrence. No exceptions.
- B. General Liability in a comprehensive form with a minimum limit of \$1,000,000.00 C.S.L. and 2,000,000.00 general aggregate.
- C. Umbrella Liability in a comprehensive form with a minimum limit of \$10,000,000.00
- D. Motor Vehicle Liability in a comprehensive form with a minimum limit of \$1,000,000.00 C.S.L. with excess covered under the General Liability Insurance policy.

## **XII. INDEMNIFY AND SAVE HARMLESS**

Vendor shall indemnify and save harmless the Robertson County Board of Education, individual Board members, officers, and employees against any and all claims, actions, demands, costs, damages, losses or expenses of any kind whatsoever, in whole or part, resulting from or connected with any acts under this Agreement or from the omission or commission of any act, lawful or unlawful, by Vendor, its agents and/or employees, including, but not limited to, court costs and attorney's fees incurred by Robertson County in connection with the defense of said matters. The County shall not in any event be liable in damages for business loss or other incidental or consequential damages of whatever kind or nature, regardless of the cause of such damage, and Vendor, and anyone claiming by or through it, expressly waives all claims to such damages.

The Agreement may not be assigned by either party without the written consent of the other.

Vendor is and remains responsible at all times for the performance of the Agreement and cannot subcontract any part of the Agreement without the express written approval of the Robertson County Board of Education. In the event that the Board of Education consents to Vendor's request to subcontract a part of the Agreement, Vendor shall accept all liability and remain responsible for the performance of all Services under the Agreement.

Neither Vendor nor the Board of Education shall be liable for failure to perform its respective obligations hereunder when such failure arises out of fire, explosion, water, act of God, civil disorder or disturbance, strikes, vandalism, war, sabotage, weather and energy related closings, governmental rules or regulations, failure of third parties to perform their obligations with respect to the Services, or like causes beyond the reasonable control of such party, or for real or personal property destroyed or damaged due to such causes. Any party experiencing such an event shall give as prompt notice as possible under the circumstances and such protection from liability shall last only for the duration of the event of such force majeure.

In the event such force majeure necessitates cancellation of Vendor's performance of the Services, in whole or in part, and an alternate date(s) cannot be agreed upon by the parties, the Board of Education will be under no obligation to compensate the Vendor for Services not performed. If such force majeure makes performance of the Services impossible, ineffective, or impractical, the Board of Education shall have the option of terminating the Agreement immediately without penalty or further expense.

### **XIII. BREACH**

A party shall be deemed to have breached the contract if any of the following occurs:

1. Failure to provide products or services that conform to contract requirements; or
2. Failure to maintain/submit any document required hereunder; or
3. Failure to perform in full or in part any of the other conditions of the contract; or
4. Violation of any warranty

### **XIV. SCHOOL SYSTEM ACTIONS IN EVENT OF A BREACH**

Upon the occurrence of any event of breach, the School System may take any one, or more, or all, of the following actions:

1. Give the Vendor a written notice of the breach requiring it to be remedied within thirty (30) days from the date of the notice, unless another time line is specified; and if the event of breach is not remedied within the time limit, terminate this contract with notice provided to the Vendor;
2. Give the Vendor a written notice specifying the event of breach and suspending all payments to be made under this contract and ordering that the portion of the contract price, which would otherwise accrue to the Vendor during the period from the date of such notice until such time as the School System(s) determines that the Vendor has cured the breach, shall never be paid to the Vendor;
3. Set off against any other obligation the School System(s) may owe to the Vendor any damages the School System(s) suffers by reason of any event of breach;
4. Treat the contract as materially breached and pursue any of its remedies at law or in equity, or both.

### **XV. TERMINATION FOR CAUSE**

If the Vendor fails to properly perform its obligations under this contract in a timely or proper manner, or if the Vendor violates any terms of this contract, Robertson County Schools shall have the right to terminate the contract and withhold payments in excess of fair compensation for completed services.

In the event the contract is terminated for due cause by the County, the County shall have the option of awarding the contract to the next lowest bidder or bidding again.

**XVI. TERMINATION FOR CONVENIENCE**

This agreement can be terminated by either party with a thirty (30) day written notice.

In the event the contract is terminated for convenience by the County, the County shall have the option of awarding the contract to the next lowest bidder or bidding again.

**XVII. RECORD RETENTION**

All vendors are required to keep books, records, and other documents for three (3) years after the Robertson County Schools makes final payments and all other pending matters are closed. Vendors must agree that the School Food Authority, the Board of Education, the State Agency, the United States Department of Agriculture, or Comptroller General may review any books, documents, papers, and records of the contractor which are directly pertinent to all negotiated contracts.

**XVIII. REGULATION COMPLIANCE**

The Vendor shall certify compliance with all applicable, laws, ordinances, rules and regulations relating to the Services operation and shall obtain all required licenses and permits, including but not limited to the following:

1. **Executive Order 11246 “Equal Employment Opportunity”**. Applies to all contracts in excess of \$10,000 by grantees and their contractors or sub grantees shall comply with Executive Order 11246, entitled “Equal Employment Opportunity”, as amended by Executive Order 11375 (October 13, 1967) and Department of Labor Regulations (41 CFR Part 60). Additional information can be obtained from the U.S. Department of Labor or the State’s Department of Labor.
2. **Clean Air and Clean Water Acts**. Applies to contracts and subcontracts in excess of \$100,000. Contractors must certify compliance with the applicable provisions of the Clean Air Act; The Clean Water Act; the Federal Water Pollution Act; Executive Order 11738; and Environmental Protection Agency regulations.
3. **Energy Policy and Conservation Act**. Applies to all contracts. Contracts must contain the appropriate mandatory standards and policies relating to energy efficiency are contained in the State’s energy conservation plan issued in compliance with the Energy Policy and Conservation Act (PL94-163,89 Statute 871) (PL94-165).
4. **Encouraging Small and Minority Owned Businesses**. To encourage business activity and ensure maximum full and open completion, efforts must be taken to solicit participation by minority firms, women’s business enterprise, labor surplus area businesses, and minority owned businesses in procurements.
5. **CFR Part 3018, Restrictions on Lobbying**. Applies to contracts and renewals in excess of \$100,000. Contractors must comply with the certification and reporting requirements of 7 CFR 3018.

6. **7 CFR Part 3017, Suspension and Debarment.** Applies to contracts expected to equal or exceed \$25,000 and contract renewals meeting the applicable dollar thresholds. Potential contractor must certify eligibility by signing the included form.
7. **7 CFR 3016.60(b), Drafting of Bid Specifications.** Requires that any person that develops or drafts specifications, requirements, statement of work, invitations for bid, requests for proposals, contract terms and conditions or other documents for use by a State, school or institution conducting a procurement under the school nutrition programs must be excluded from competing for such procurements.
8. **7 CFR 3016.4(b), 3016.36(c), Local Geographical Preferences.** Local geographical preferences shall be prohibited as specified in 7CFR Part 3016, and prohibits the use of statutorily or administratively imposed in-state or local geographic preferences.
9. **Robertson County, Tennessee Letter of Compliance.** Pursuant to T.C.A. § 49-5-413 and applicable to Robertson County School projects only.
10. **Robertson County, Tennessee Non-Collusion Affidavit.** Drug Free Workplace Affidavit pursuant to T.C.A. § 50-9-113.
11. **Buy American.** Bidders must comply with the "Buy American" provision as in Policy memorandum 210.21-14, if applicable.

**Buy American Requirement.** The “Buy American Requirement” requires that schools and institutions participating in the National School Lunch Program (NSLP) in the United States purchase, to the maximum extent practicable, domestically grown and processed foods. Please note that this rule applies to “Private Labels” as well as other labels. The legislation defines “domestic commodity or product” as one that is produced and processed in the United States substantially using agricultural commodities that are produced in the United States. The report accompanying the legislation stipulated that “substantially” means that over 51 percent of the final processed product consists of agricultural commodities that were grown domestically. SNP requires vendor to complete Buy American Certificate (enclosed), and update/submit with every bid renewal.

## **XIX. CODE OF CONDUCT**

The following conduct will be expected of all persons who are engaged in the awarding and administration of contracts supported by School Food and Nutrition Program Funds.

1. No employee, officer or agent of named School District shall participate in the selection or in the award or administration of a contract if a conflict of interest, really or apparent, would be involved.
2. Conflicts of interest arise when one of the following has a financial or other interest in the firm selected for the award.
  - (A) The employee, officer or agent.
  - (B) Any member of the immediate family.
  - (C) His or her partner.
  - (D) An organization which employs or is about to employ the above.

3. The Robertson County Board of Education employees, officers, or agents shall neither solicit nor accept gratuities, favors, or anything of monetary value from contractors, potential contractors, or parties to sub-agreements.
4. Penalties for violation of the code of conduct should be:
  - (A) Reprimand by the Board of Education.
  - (B) Dismissal by the Board of Education.
  - (C) Any legal action necessary.
5. The removal of any food, supplies, equipment, or school property is prohibited. The purchase of any food or service from a contractor for individual use is prohibited using school bid prices.

**XX. REQUIRED FORMS:**

The included forms that **must** be returned as part of the SEALED BID package to the Robertson County Finance Department, Attn: Taylor Tomblin, Purchasing Agent, are:

- (A) Equal Opportunity Employee Act of 1975 Certificate
- (B) Certification Regarding Debarment
- (C) Certification Regarding Lobbying
- (D) Contract Agreement Form
- (E) Vendor Guarantees
- (F) Non-Collusion Affidavit
- (G) Certification of Independent Price Determination
- (H) Letter of Compliance
- (I) Drug-Free Workplace Affidavit
- (J) Iran Divestment Act
- (K) Authorized Bid Response Exhibit A

## School Nutrition Civil Rights Statement

In accordance with Federal civil rights law and U.S. Department of Agriculture (USDA) civil rights regulations and policies, the USDA, its Agencies, offices, and employees, and institutions participating in or administering USDA programs are prohibited from discriminating based on race, color, national origin, sex, disability, age, or reprisal or retaliation for prior civil rights activity in any program or activity conducted or funded by USDA.

Persons with disabilities who require alternative means of communication for program information (e.g. Braille, large print, audiotape, American Sign Language, etc.), should contact the Agency (State or local) where they applied for benefits. Individuals who are deaf, hard of hearing or have speech disabilities may contact USDA through the Federal Relay Service at (800) 877-8339. Additionally, program information may be made available in languages other than English.

To file a program complaint of discrimination, complete the USDA Program Discrimination Complaint Form, (AD-3027) found online at: [http://www.ascr.usda.gov/complaint\\_filing\\_cust.html](http://www.ascr.usda.gov/complaint_filing_cust.html), and at any USDA office, or write a letter addressed to USDA and provide in the letter all of the information requested in the form.

To request a copy of the complaint form, call (866) 632-9992. Submit your completed form or letter to USDA by:

(1) Mail: U.S. Department of Agriculture  
Office of the Assistant Secretary for Civil Rights  
1400 Independence Avenue, SW  
Washington, D.C. 20250-9410;

(2) Fax: (202) 690-7442; or

(3) Email: [program.intake@usda.gov](mailto:program.intake@usda.gov).

This institution is an equal opportunity provider.

**EQUAL OPPORTUNITY EMPLOYEE ACT OF 1975**

The Robertson County Public School District is in firm support of the provisions of the Equal Opportunity Act of 1975. We, therefore, must be assured by the successful manufacturer in this bid that he/she is an equal opportunity employer according to the provisions of the act. We, therefore, require the following certification by each successful bidder as part of the contract documents:

**CERTIFICATE**

I/We hereby certify that the \_\_\_\_\_

\_\_\_\_\_ is an equal opportunity employer as defined in the Equal Opportunity Act of 1975.

Upon request we will show proof that our employment practices do meet in every respect the requirements of the Equal Opportunity Act of 1975.

\_\_\_\_\_  
Owner or Officer of Firm Signature

\_\_\_\_\_  
Date

\_\_\_\_\_  
Title



**Certification Regarding Debarment, Suspension, Ineligibility and Voluntary Exclusion – Lower Tier Covered Transactions**  
(Before completing certification, read instructions)

- (1) The prospective lower tier participant certifies, by submission of this proposal, that neither it nor its Principals is presently debarred, suspended, proposed for debarment, declared ineligible or voluntarily excluded from participation in this transaction by any Federal department or agency.
- (2) Where the prospective lower tier participant is unable to certify to any of the statement in this Certification, such prospective participant shall attach an explanation to this proposal.

---

Organization

Name Bid Number

---

Name(s) and Title(s) of Authorized Representative(s)

---

Signature(s)

Date

**Instructions for Certification**

- (1) By signing and submitting this form, the prospective lower tier participant is providing the certification set out on the reverse side in accordance with these instructions.
- (2) The certification in this clause is a material representation of fact upon which reliance was placed when this transaction was entered into. If it is later determined that the prospective lower tier participant knowingly rendered an erroneous certification, in addition to other remedies available to the Federal Government, the department or agency with which this transaction originated may pursue available remedies, including suspension and/or debarment.
- (3) The prospective lower tier participant shall provide immediate written notice to the person to whom this proposal is submitted if at any time the prospective lower tier participant learns that its certification was erroneous when submitted or has become erroneous by reason of changed circumstances.
- (4) The terms "covered transaction", "debarred", "suspended", "ineligible", "lower tier covered transaction", "participant", "person", "primary covered transaction", "principal", "proposal", and "voluntarily excluded", as used in this clause, have the meanings set out in the Definition and Coverage sections of rules implementing Executive Order 12549. You may contact the person to which this proposal is submitted for assistance in obtaining a copy of those regulations.
- (5) The prospective lower tier participant agrees by submitting this form that, should the proposed covered transaction be entered into, it shall not knowingly enter into any lower tier covered transaction with a person who is debarred, suspended declared ineligible, or voluntarily excluded from participation in this covered transaction, unless authorized by the department or agency with which this transaction originated.
- (6) The prospective lower tier participant further agrees by submitting this form that it will include this clause titled "Certification Regarding Debarment, Suspension, Ineligibility and Voluntarily Exclusion – Lower Tier Covered Transactions", without modification, in all lower tier covered transactions and in all solicitations for lower tier covered transactions.
- (7) A participant in a covered transaction may rely upon a certification of a prospective participant in a lower tier covered transaction that it is not debarred, suspended, ineligible, or voluntarily excluded from the covered transaction, unless it knows that the certification is erroneous. A participant may decide the method and frequency by which it determines the eligibility of its principals. Each participant may, but is not required to, check with the Non-procurement List.
- (8) Nothing contained in the foregoing shall be construed to require establishment of a system of records in order to render in good faith the certification required by this clause. The knowledge and information of a participant is not required to exceed that which is normally possessed by a prudent person in the ordinary course of business dealings.
- (9) Except for transaction authorized under paragraph 5 of these instructions, if a participant in a covered transaction knowingly enters into a lower tier covered transaction with a person who is suspended, debarred, ineligible, or voluntarily excluded from participation in this transaction, in addition to other remedies available to the Federal Government, the department or agency with which this transaction originated may pursue available remedies including suspension and/or debarment.

Item (B)

**THIS DATA CURRENT AS OF THE FEDERAL REGISTER DATED  
FEBRUARY 25, 2002**

**7 CFR – CHAPTER XXX – PART 3018**

[View Part](#)

**Appendix A to Part 3018 – Certification Regarding Lobbying  
Certification for Contracts, Grants, Loans, and Cooperative Agreements**

The undersigned certifies, to the best of his or her knowledge and belief, that:

- (1) No Federal appropriated funds have been paid or will be paid, by or on behalf of the undersigned, to any person for influencing or attempting to influence an officer or employee of an agency, a Member of Congress, an officer or employee of Congress, or an employee of a Member of Congress in connection with the awarding of any Federal contract, the making of any Federal grant, the making of any Federal loan, the entering into of any cooperative agreement, and the extension, continuation, renewal, amendment, or modification of any Federal contract, grant, loan, or cooperative agreement.
- (2) If any funds other than Federal appropriated funds have been paid or will be paid to any person for influencing or attempting to influence an officer or employee of any agency, a Member of Congress, an officer or employee of Congress, or an employee of a Member of Congress in connection with this Federal contract, grant, loan, or cooperative agreement, the undersigned shall complete and submit Standard Form-LLL, “Disclosure Form to Report Lobbying”, in accordance with its instructions.
- (3) The undersigned shall require that the language of this certification be included in the award documents for all sub-awards at all tiers (including sub-contracts, sub-grants, and contracts under grants, loans, and cooperative agreements) and that all sub-recipients shall certify and disclose accordingly. This certification is a material representation of fact upon which reliance was placed when this transaction was made or entered into. Submission of this certification is a prerequisite for making or entering into this transaction imposed by section 1352, title 31, U.S. Code. Any person who fails to file the required certification shall be subject to a civil penalty of not less than \$10,000 and not more than \$100,000 for each such failure.

**Statement for Loan Guarantees and Loan Insurance**

The undersigned states, to the best of his or her knowledge and belief, that:

If any funds have been paid or will be paid to any person for influencing or attempting to influence an officer or employee of any agency, a Member of Congress, an officer or employee of Congress, or an employee of a Member of Congress in connection with this commitment providing for the United States to insure or guarantee a loan, the undersigned shall complete and submit Standard Form-LLL, “Disclosure Form to Report Lobbying”, in accordance with its instructions.

Submission of this statement is a prerequisite for making or entering into this transaction imposed by section 1352, title 31, U.S. Code. Any person who fails to file the required statement shall be subject to a civil penalty of not less than \$10,000 and not more than \$100,000 for each such failure.

<http://www.access.gpo.gov/ecfr>

Item (C)

## CERTIFICATION REGARDING LOBBYING

Applicable to Grants, Sub-grants, Cooperative Agreements, and Contracts Exceeding \$100,000 in Federal Funds.

Submission of this certification is a prerequisite for making or entering into this transaction and is imposed by section 1352, title 31, U.S. Code. This certification is a material representation of fact upon which reliance was placed when this transaction was made or entered into. Any person who fails to file the required certification shall be subject to a civil penalty of not less than \$10,000 and not more than \$100,000 for each such failure.

The undersigned certifies, to the best of his or her knowledge and belief, that:

1. No Federal appropriated funds have been paid or will be paid, by or on behalf of the undersigned, to any person for influencing or attempting to influence an officer or employee of any agency a Member of Congress, an officer or employee of Congress, or an employee of a Member of Congress in connection with the awarding of a Federal contract, the making of a Federal grant, the making of a Federal loan, the entering into of a cooperative agreement, and the extension, continuation, renewal, amendment, or modification of a Federal contract, grant, loan, or cooperative agreement.
2. If any funds other than Federal appropriated funds have been paid or will be paid to any person for influencing or attempting to influence an officer or employee of any agency, a Member of Congress, an officer or employee of Congress, or an employee of a Member of Congress in connection with this Federal grant or cooperative agreement, the undersigned shall complete and submit Standard Form – LLL, “Disclosure Form to Report Lobbying”, in accordance with its instructions.
3. The undersigned shall require that the language of this certification be included in the award documents for all covered sub-awards exceeding \$100,000 in Federal funds at all appropriate tiers and that all sub-recipients shall certify and disclose accordingly.

---

FNS Grant/Cooperative Agreement

---

Name/Address of Organization

---

Name/Title of Submitting Official

---

Signature

Item (C)

**ROBERTSON COUNTY SCHOOL BOARD OF EDUCATION  
CONTRACT AGREEMENT**

The undersigned agrees to furnish equipment and installation at the prices submitted herein as per stated specifications of this IFB if awarded the bid contract. We affirm that no Robertson County Board Member or Employee will receive a gift or other things of value as a result of this order.

Company Name : \_\_\_\_\_

Company Street Address: \_\_\_\_\_

Company Mailing Address: \_\_\_\_\_

City, State Zip: \_\_\_\_\_

\_\_\_\_\_  
Authorized Officer or Agent Signature

\_\_\_\_\_  
Date

Printed Name and Title: \_\_\_\_\_

Email address: \_\_\_\_\_

**Robertson County Board of Education  
800 M.S. Couts Boulevard  
Springfield, TN 37172**

**VENDOR GUARANTEES, WARRANTIES, ETC.**

---

---

---

I HAVE READ THE GENERAL TERMS AND CONDITIONS AND SPECIFICATIONS OF THIS BID SOLICITATION AND AGREE TO ABIDE BY SAME.

---

BID NUMBER & RECEIPT DATE OF BID	COMPANY NAME
----------------------------------	--------------

---

VENDOR REPRESENTATIVE SIGNATURE (MUST BE SIGNED)	REPRESENTATIVE TITLE
---	----------------------

---

STATE/BUSINESS LICENSE NUMBER	LICENSE EXPIRATION DATE
-------------------------------	-------------------------

Item (E)

**Robertson County, Tennessee  
NON-COLLUSION AFFIDAVIT**

The agent of the bidding firm hereby certifies to the best of his/her knowledge and belief that this bid proposal to Robertson County, Tennessee has not been prepared in collusion with any other seller of similar products. The agent also certifies that the prices, terms and conditions of said bid proposal have not been communicated by the undersigned, nor by any employee or agent of the bidding firm, to any other seller of similar products and will not be communicated to any such seller prior to the official opening of said bid. The agent further states that no official or employee of Robertson County Government has promised any personal financial or other beneficial interest, either directly or indirectly in order to influence award of this bid.

---

**Authorized Signature, Title (Owner/ Corporate Officer)**

**Date**

**Printed Name:** \_\_\_\_\_

---

**Company Name**

---

**Mailing Address**

---

**Telephone No.**

**Fax No.**

**Certificate of Independent Price Determination**

(A) By submission of this offer, the offeror certifies and in the case of a joint offer, each part thereto certifies as to its own organization, that in connection with this procurement:

- (1) The prices in this offer have been arrived at independently, without consultation, communication, or agreement, for the purpose of restricting competition, as to any matter relating to such prices with any other offeror or with any competitor;
- (2) unless otherwise required by law, the prices which have been quoted in this offer have not been knowingly disclosed by the offeror and will not knowingly be disclosed by the offeror prior to bid opening in the case of an advertised procurement or prior to award in the case of a negotiated procurement, directly or indirectly to any other offeror or to any competitor; and
- (3) no attempt has been made or will be made by the offeror to induce any person or firm to submit or not to submit, and offer for the purpose of restricting competition.

(B) Each person signing this offer certifies that:

- (1) He or she is the person in the offeror’s organization responsible within the organization for the decision as to the prices being offered herein and he or she has not participated, and will not participate, in any action contrary to (A)(3) above; or
- (2) he or she is not the person in other offeror’s organization responsible within the organization for the decision as to the prices being offered herein, but that he or she has been authorized in writing to act as agent for the persons responsible for such decision in certifying that such person have not participated and will not participate, in any action contrary to (A)(1) through (A)(3) above, and as their agent does hereby so certify; and he or she has not participated, and will not participate, in any action contrary to (A)(1) through (A)(3).

---

Signature of Vendor’s Authorized Representative

---

Title Date

In accepting this offer, the sponsor certifies that the sponsor’s officers, employees or agents have not taken any action which may jeopardized the independence of the offer referred to above.

---

Signature of Vendor’s Authorized Representative

Item (G)

**Robertson County, Tennessee  
Letter of Compliance**

Successful bidder must comply with and provide this Letter of Compliance.

Amendments to the Tennessee Code Annotated Section 49-5-413 require employers doing business with the Robertson County Board of Education to have their employees' criminal history records checked. No employer or employee shall come in direct contact with school children, children in a childcare program, and/or enter the grounds of a school or childcare center operated by the Robertson County Board of Education when children are present without this compliance letter on file.

---

Authorized Signature, Title (Owner/ Corporate Officer) Date

Printed Name: \_\_\_\_\_

---

Company Name

---

Mailing Address

---

Telephone No. Fax No.



DRUG-FREE WORKPLACE AFFIDAVIT

The undersigned, principal officer of \_\_\_\_\_, an employer of five (5) or more employees contracting with Robertson County, Tennessee government to provide construction services, hereby states under oath as follows:

1. The undersigned is a principal officer of \_\_\_\_\_ (hereinafter referred to as the "Company"), and is duly authorized to execute this Affidavit on behalf of the Company.
2. The Company submits this Affidavit pursuant to T.C.A. § 50-9-113, which requires each employer with no less than five (5) employees receiving pay who contracts with the state or any local government to provide construction services to submit an affidavit stating that such employer has a drug-free workplace program that complies with Title 50, Chapter 9, of the Tennessee Code Annotated.
3. The Company is in compliance with T.C.A. § 50-9-113.

\_\_\_\_\_  
Authorized Signature, Title (Owner/ Corporate Officer) Date

Printed Name: \_\_\_\_\_

\_\_\_\_\_  
Company Name

\_\_\_\_\_  
Mailing Address

\_\_\_\_\_  
Telephone No. Fax No.

Witness signature : \_\_\_\_\_ Date: \_\_\_\_\_

Witness printed name: \_\_\_\_\_

## STATE OF TENNESSEE IRAN DIVESTMENT ACT AGREEMENT

By submission of this bid, each bidder and each person signing on behalf of any bidder certifies, and in the case of a joint bid each party thereto certifies as to its own organization, under penalty of perjury, that to the best of its knowledge and belief that each bidder is not on the list created pursuant to Tennessee Code Annotated § 12-12-106.

Tenn. Code Ann. § 12-12-106 requires the chief procurement officer to publish, using credible information freely available to the public, a list of persons it determines engage in investment activities in Iran, as described in § 12-12-105.

While inclusion on this list would make a person ineligible to contract with the state of Tennessee, if a person ceases its engagement in investment activities in Iran, it may be removed from the list.

If you feel as though you have been erroneously included on this list please contact the Central Procurement Office at [CPO.Website@tn.gov](mailto:CPO.Website@tn.gov).

---

COMPANY NAME

---

DATE

---

REPRESENTATIVE

---

TITLE

Item (J)

**Exhibit A - Vendor Response Form**  
**BID 1433: Serving Line at East Robertson High School**

Pricing must be firm for the contract period. Pricing must include any fuel surcharges, fees, misc. charges, etc. which contributes to the total expense charged to Robertson County. Prices effective February 1, 2020 through January 31, 2021.

	<b>Item Description</b>	<b>Quantity</b>	<b>Unit Price</b>	<b>Total Price</b>
<b>ITEM 1</b>	Hot Well Unit	1 EACH	\$	\$
<b>ITEM 2</b>	Mechanically Cooled Cold Pan	1 EACH	\$	\$
<b>ITEM 3</b>	Mechanically Cooled Cold Pan	1 EACH	\$	\$
<b>ITEM 4</b>	Hot Well Unit	1 EACH	\$	\$
<b>ITEM 5</b>	Cashier Counter	1 EACH	\$	\$
<b>ITEM 6</b>	Mechanically Cooled Cold Pan	1 EACH	\$	\$
			<b>TOTAL FOR SERVING LINE</b>	\$

**Days Until Delivery From Order:** \_\_\_\_\_

Date: \_\_\_\_\_

Authorized Signature, Title (Owner / Corporate Officer): \_\_\_\_\_

Company Name: \_\_\_\_\_

Mailing Address: \_\_\_\_\_

Phone Number: \_\_\_\_\_ Fax Number: \_\_\_\_\_

Email Address: \_\_\_\_\_

Item (K)

East Robertson High School

Robertson County, TN

## **Item #1 and #4**

### Hot Well Units

Delfield ShelleySteel or Pre-Approved Equivalent Brand

**Exterior Body:** to be constructed of 18-gauge stainless steel panels and 14-gauge galvanized bottom. All exterior side panels are reinforced with overlapping corners and are welded in place. All body cutouts are reinforced with 14-gauge galvanized channel supports. Unit to be 36" high. Base modified to 66".

**Exterior Top:** to be constructed of 14-gauge stainless steel, welded, ground and polished into one integral unit. Top is fabricated with square exterior corners. Top has FOUR electrically heated, recessed, die-stamped stainless steel hot food warmers. Each warmer accommodates one 12.75" x 20.75" x 6" pan. Each well to have a drain. Recessed top to accommodate sheet pans.

Heated food warmers are constructed of die-stamped stainless steel. Heated food warmers are insulated on the bottom. (4) ENERGY SAVING power wells. 208/230 volt. Hot Food Drains.

Unit to have a Power Pole for cord and plug. Electrical to be piggybacked according to the plan.

B-60 new style 12" "v" tray slide. To be mounted at 34" high.

E-60 Fold down S/S work shelf 10" wide, mounted on operator side 36" high.

Line up Interlocks.

To verify laminate finish.

Plexiglass standoff décor panel with graphic.

6" adjustable legs.

S/S Open under storage.

Unit to have glass front counter protector. Easily converts to three positions without the use of tools. Narrow Halogen heat lamp with XENON Lights or equivalent brand.

## Item #2 and #3

### Mechanically Cooled Cold Pan

Delfield ShelleySteel or Pre-Approved Equivalent Brand

**Exterior Body:** to be constructed of 18-gauge stainless steel panels and 14-gauge galvanized bottom. All exterior side panels are reinforced with overlapping corners and are welded in place. All body cutouts are reinforced with 14-gauge galvanized channel supports. Unit to be 36" high. Top extension to be 51" long with offset to accommodate Flexishield.

**Exterior Top:** to be constructed of 14-gauge stainless steel, welded, ground and polished into one integral unit. Top is fabricated with square exterior corners. 50" refrigerated cold pan serving counter. Recessed wells to accommodate 18x26" sheet pans.

B-50 50" new style stainless steel 12" "V" tray slide to be mounted at 34". Mitered end.

Line up Interlocks.

To verify Laminate.

Plexiglass standoff décor panel with graphic

6" adjustable legs

S/S open under storage

Piggyback electrical per plan.

Unit to have glass front counter protector model. Two Tier unit. Easily converts to three positions without the use of tools. LED Lights

## Item #5

### Cashier Counter

Delfield ShelleySteel or Pre-Approved Equivalent Brand

**Exterior Body:** to be constructed of 18-gauge stainless steel panels and 14-gauge galvanized bottom. All exterior side panels are reinforced with overlapping corners and are welded in place. All body cutouts are reinforced with 14-gauge galvanized channel supports. Unit to be 36" high. Modified to be a dual cashier stand.

**Exterior Top:** to be constructed of 14-gauge stainless steel, welded, ground and polished into one integral unit. Top is fabricated with square exterior corners. Two (2) ferruled holes are located at the rear of the top to allow cord access for cash register. Two (2) locking cash drawers. Two (2) 120V-15A duplex receptacles with 10.0A breaker.

**Interior Lining:** At the cashier's end is 18-gauge stainless steel with a stainless steel bottom shelf.

B -30 30" new style "v" tray slide 12" wide with 3 ribs located on customer and operator side 34" high. Located on the left and right.

Line Up interlock

To verify laminate finish.

Plexiglass standoff décor panel with graphic

6" adjustable legs.

Piggyback unit per plan.

## Item #6

### Mechanically Cooled Cold Pan

Delfield ShelleySteel or Pre-Approved Equivalent Brand

**Exterior Body:** to be constructed of 18-gauge stainless steel panels and 14-gauge galvanized bottom. All exterior side panels are reinforced with overlapping corners and are welded in place. All body cutouts are reinforced with 14-gauge galvanized channel supports. Unit to be 36" high. Depth Modified.

**Exterior Top:** to be constructed of 14-gauge stainless steel, welded, ground and polished into one integral unit. Top is fabricated with square exterior corners. 50" refrigerated cold pan serving counter. Recessed wells to accommodate 18x26" sheet pans.

B-50 50" new style stainless steel 12" "V" tray slide to be mounted at 34". Mitered end.

Line up Interlocks.

To verify Laminate.

Plexiglass standoff décor panel with graphic

6" adjustable legs

S/S open under storage

Piggyback electrical per plan.

Unit to have glass front counter protector model. Single Tier unit for dual service. LED Lights

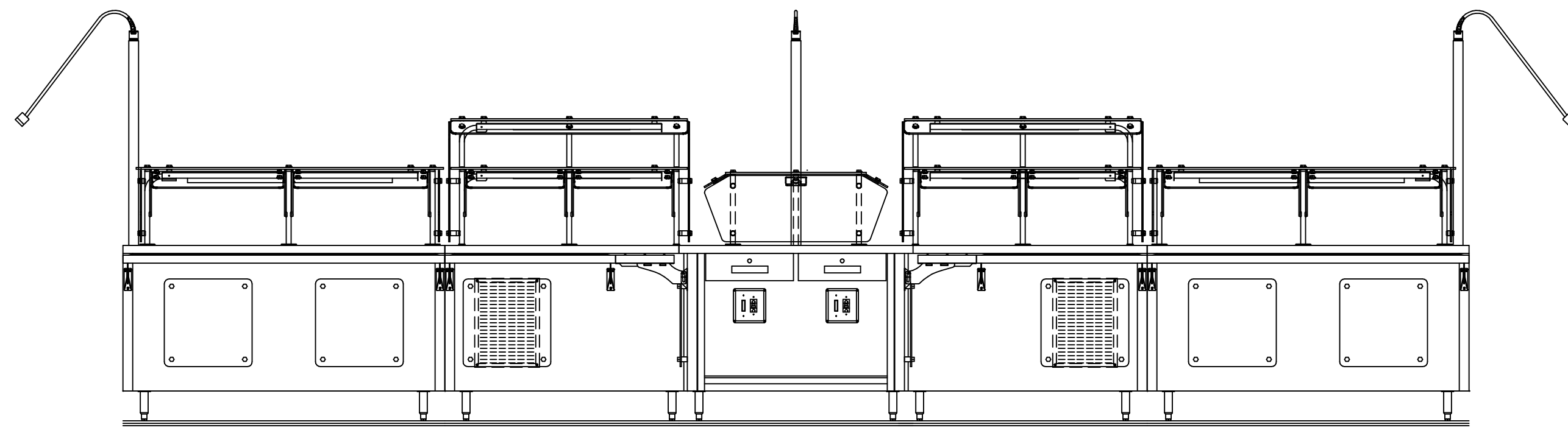

APPROVED FOR FABRICATION

APPROVED  
 APPROVED AS NOTED  
 RESUBMIT

COMPANY: \_\_\_\_\_ DATE: \_\_\_\_\_

If you are placing equipment into an area which has certain standards or codes other than those normally accepted, it is the responsibility of the user to verify that the equipment meets the requirements of those standards. It is the responsibility of the user to verify that the equipment meets the requirements of those standards. It is the responsibility of the user to verify that the equipment meets the requirements of those standards.

**Shelleysteel**

NOTES:

- \* TOPS ARE TO BE 14 GAUGE S/S
- \* PROVIDE INTERLOCKS AS REQUIRED
- \* ALL STANDARD LOCKING POLYURETHANE CASTERS
- \* CORDS STANDARD WITH 90° PLUGS
- \* UNITS SPECIFIED WITH DRAINS TO HAVE GATE VALVE AND GARDEN HOSE HOOK UP
- \* SHELLEYSSTEEL (LAMINATED): PROVIDE ANGULAR FRAME BASES WITH LAMINATE SIDE PANELS
- \* VERIFY COLOR
- \* WHEN TRAY SLIDE/WORK SHELF BRACKETS ARE USED: FOLD DOWN BRACKETS ARE STANDARD UNLESS OTHERWISE REQUESTED
- \* ALL 120 VOLT RECEPTACLES (15 AND 20 AMP) WILL BE GFCI PROTECTED DUPLEXES

ENVIRONMENTALLY FRIENDLY INSULATION

- KYOTO PROTOCOL COMPLIANT
- NON O.D.P. (OZONE DEPLETION POTENTIAL)
- NON G.W.P. (GLOBAL WARMING POTENTIAL)
- POLYURETHANE INSULATION

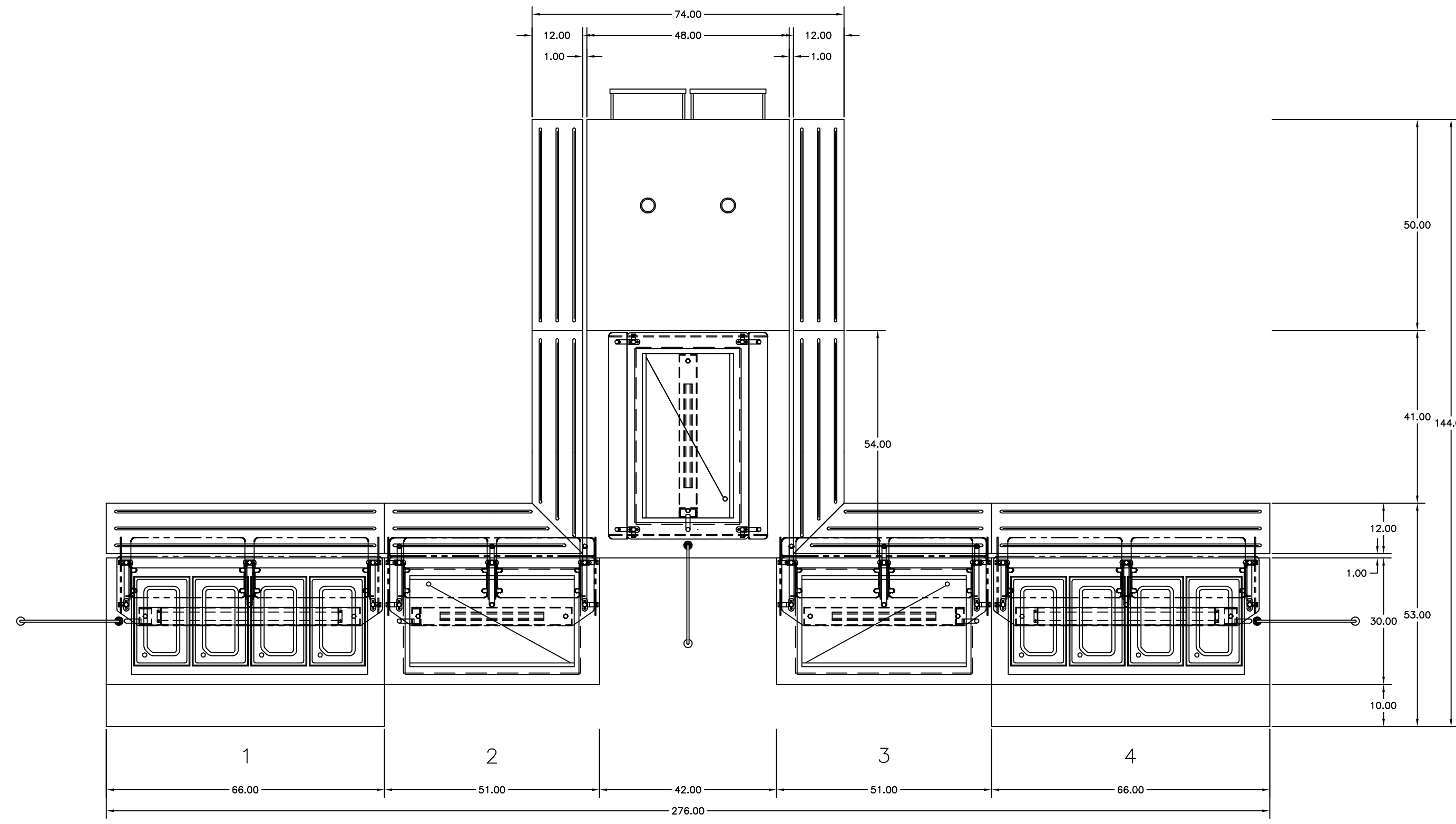
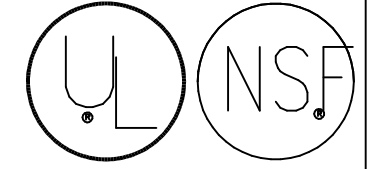
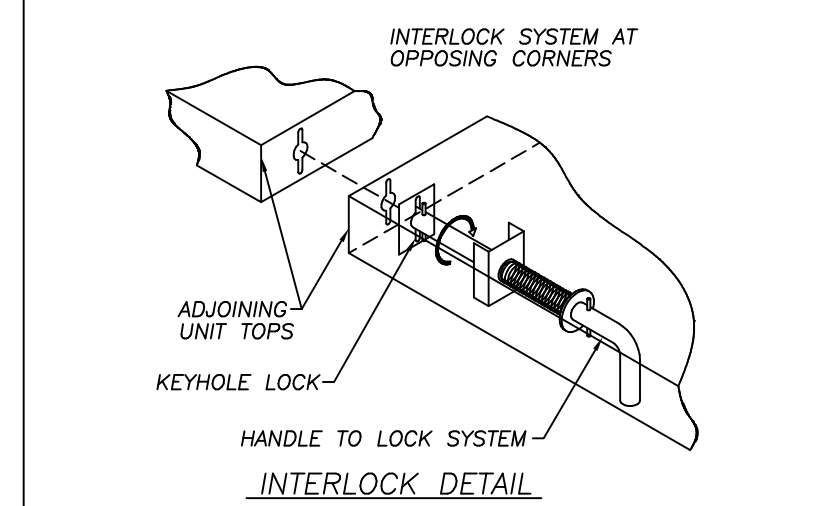

SKU NO. 000-CCAI0YPV6  
 MODEL NO. DCFSSD ITEM NO. 6A

-SINGLE TIER, DOUBLE  
 -SERVICE FLEXIBLE FEED SHIELD  
 -CONVERTS TO THREE POSITIONS  
 -SUPPORTS WITH S/S FINISH AND CHROME MOUNTING HARDWARE  
 -0.38 TEMPERED GLASS TOP  
 -0.25 TEMPERED GLASS FRONT AND ENDS  
 -(1) 24.00 LED LIGHT (120V-5.83A)

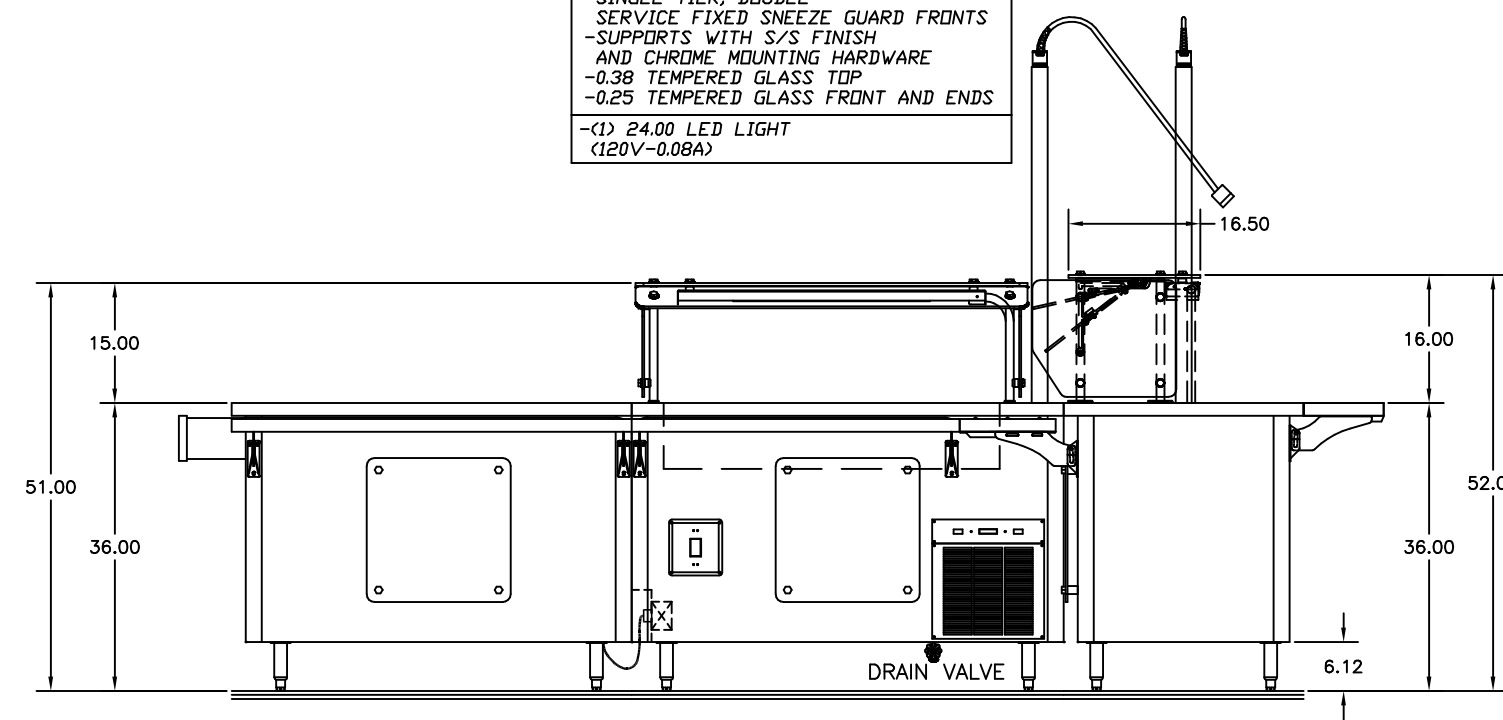

SKU NO. 000-CCAI0YPVC  
 MODEL NO. DCFSSS ITEM NO. 1A

-SINGLE TIER, SINGLE  
 -SERVICE FLEXIBLE FEED SHIELD  
 -CONVERTS TO THREE POSITIONS  
 -SUPPORTS WITH S/S FINISH AND CHROME MOUNTING HARDWARE  
 -0.38 TEMPERED GLASS TOP  
 -0.25 TEMPERED GLASS FRONT AND ENDS  
 -INSTALL (1) 4" HATCO HALOGEN HEATLAMP W/ XENON LIGHTS (120V-5.83A)

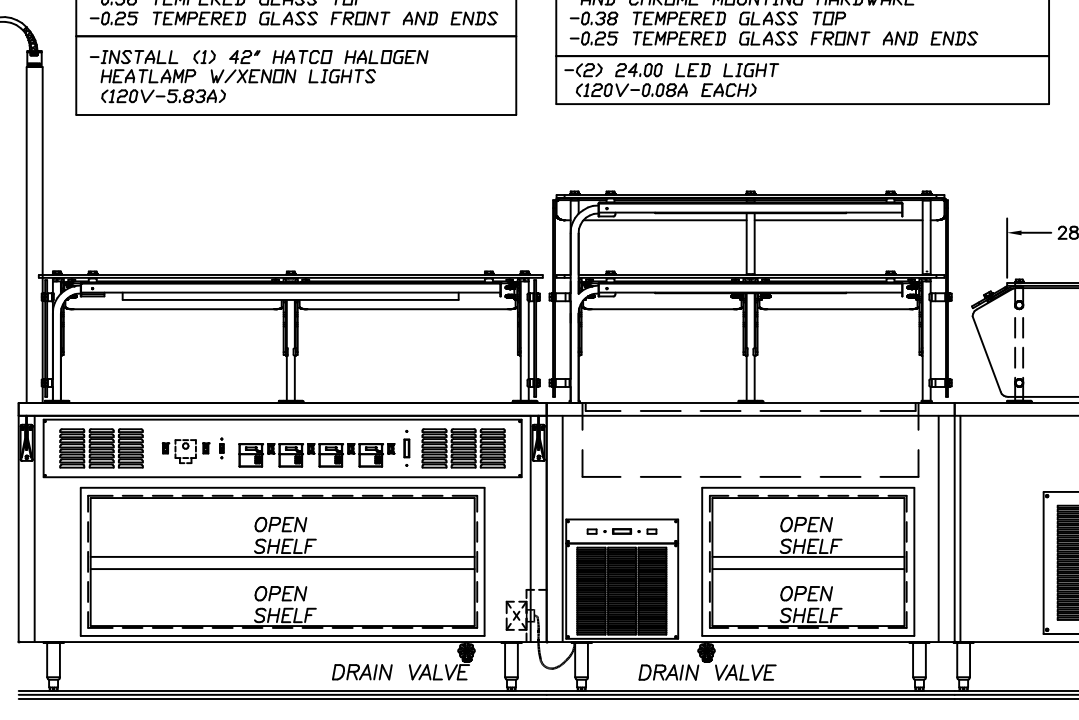

SKU NO. 000-CCAI0YPVF  
 MODEL NO. DCFSSP ITEM NO. 3A

-DOUBLE TIER, SINGLE SERVICE FLEXIBLE FEED SHIELD  
 -TOP TIER FIXED SNEEZEGUARD FRONT  
 -BOTTOM TIER CONVERTS TO THREE POSITIONS  
 -SUPPORTS WITH S/S FINISH AND CHROME MOUNTING HARDWARE  
 -0.38 TEMPERED GLASS TOP  
 -0.25 TEMPERED GLASS FRONT AND ENDS  
 -(2) 24.00 LED LIGHT (120V-0.88A EACH)

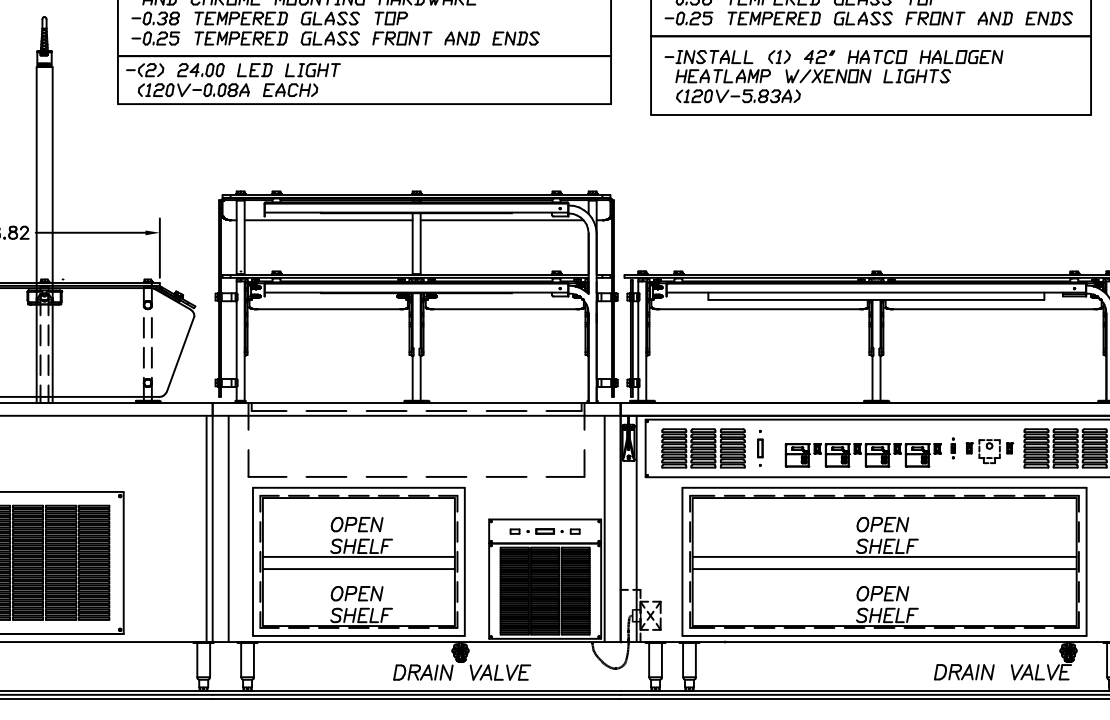

SKU NO. 000-CCAI0YPVD  
 MODEL NO. DCFSSP ITEM NO. 4A

-DOUBLE TIER, DOUBLE SERVICE FLEXIBLE FEED SHIELD  
 -CONVERTS TO THREE POSITIONS  
 -SUPPORTS WITH S/S FINISH AND CHROME MOUNTING HARDWARE  
 -0.38 TEMPERED GLASS TOP  
 -0.25 TEMPERED GLASS FRONT AND ENDS  
 -INSTALL (1) 4" HATCO HALOGEN HEATLAMP W/ XENON LIGHTS (120V-5.83A)

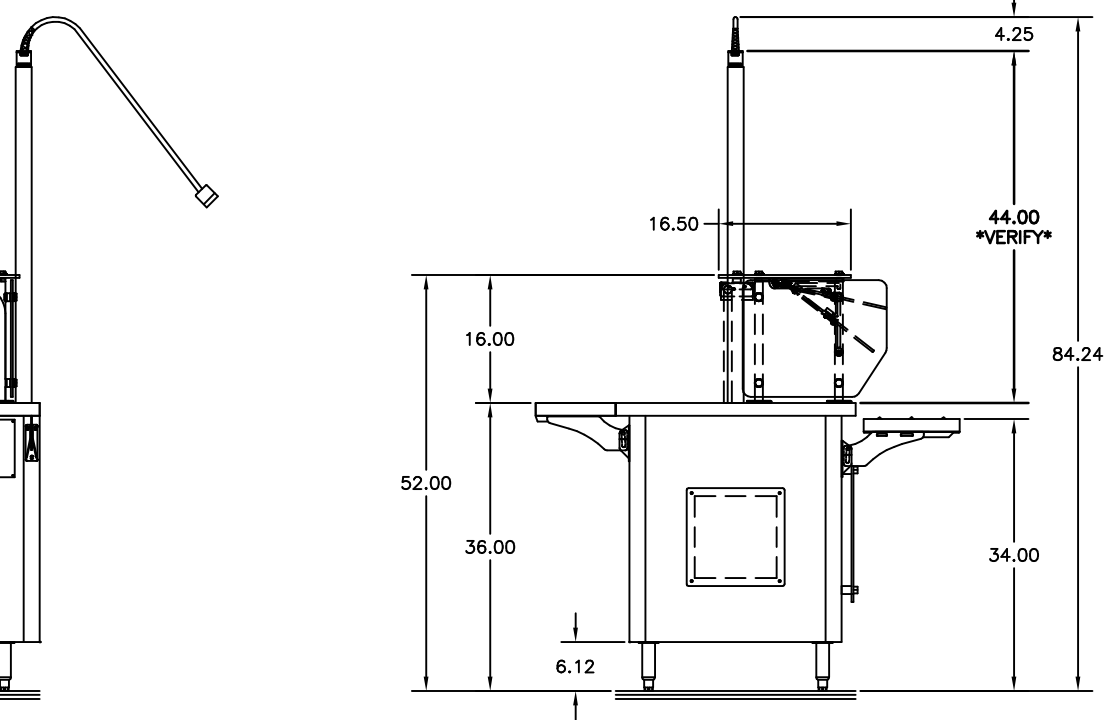

END ELEVATION ITEM #4 ONLY

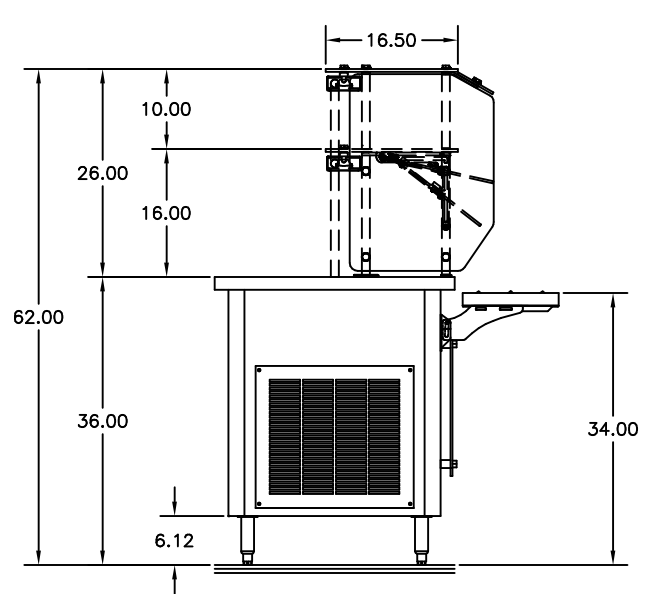

END ELEVATION ITEM #3 ONLY

SKU NO. 000-40010YPV5  
 MODEL NO. SSC-50 ITEM NO. 5

-DUAL CASHIER COUNTER  
 -(2) 3 IN. DIAMETER HOLE WITH GROMMET IN TOP  
 -(2) S/S SHELF AND LOCKING DRAWER  
 -(2) 14GA S/S CONSTRUCTED ROLLED "V" TRAY SLIDES  
 -MOUNTED ON FOLD-DOWN BRACKETS  
 -(2) 120V-15A DUPLEX (GFCI) RECEPTACLE, NEMA #5-15R WITH 100A BREAKERS  
 -(2) DECOR PANELS  
 -HARDWARE COLOR VERIFY  
 -NEMA NO. 14-30 PLUG W/ 9FT CORD  
 120/208-230V-60C-1PH-1ØA  
 -TO PIGGYBACK INTO UNIT AT RIGHT

SKU NO. 000-40010YPV6  
 MODEL NO. SSC-50-9P1 ITEM NO. 6

-COLD PAN SERVING COUNTER  
 -39.00 BY 21.62 BY 7.00 MECH. COOLED COLD PAN WITH DRAIN  
 115V-60C-1PH-2.4A-1/2HP  
 -4" DEEP PANS BY OTHERS  
 -RECESSED FOR SHEET PANS  
 -(2) 14GA S/S CONSTRUCTED ROLLED "V" TRAY SLIDES  
 -MOUNTED ON FOLD-DOWN BRACKETS  
 -(2) DECOR PANELS  
 -HARDWARE COLOR VERIFY  
 -POWER POLE FOR CORD & PLUG  
 -(1) 120V-2.56A SINGLE RECEPTACLE, NEMA #14-50R  
 -PROVIDE WITH GFCI BREAKER  
 -PIGGYBACK FROM UNIT AT LEFT  
 -NEMA NO. 14-30 PLUG W/ 9FT CORD  
 120/208-230V-60C-1PH-16.63A

SKU NO. 000-40010YPV1  
 MODEL NO. SH-4-4M1 ITEM NO. 1

-HEATED SERVING COUNTER  
 -ELECTRIC LDU WATT (WET OR DRY)  
 HOT FOOD TABLE WITH DRAINS AND MANTLED  
 208-230V-60C-1PH-10.8A  
 -RECESSED FOR SHEET PANS  
 -(4) 14GA S/S CONSTRUCTED ROLLED "V" TRAY SLIDE  
 -MOUNTED ON FOLD-DOWN BRACKETS  
 -S/S CONSTRUCTED WORKSHELF  
 -MOUNTED ON FOLD-DOWN BRACKETS  
 -(2) DECOR PANELS  
 -HARDWARE COLOR VERIFY  
 -POWER POLE FOR CORD & PLUG  
 -(1) 120V-2.56A SINGLE RECEPTACLE, NEMA #5-15R  
 -PIGGYBACK FROM UNIT AT RIGHT  
 -NEMA NO. 14-30 PLUG W/ 9FT CORD  
 120/208-230V-60C-1PH-16.63A

SKU NO. 000-40010YPV2  
 MODEL NO. SSC-50-9P1 ITEM NO. 2

-COLD PAN SERVING COUNTER  
 -39.00 BY 21.62 BY 7.00 MECH. COOLED COLD PAN WITH DRAIN  
 115V-60C-1PH-2.4A-1/2HP  
 -4" DEEP PANS BY OTHERS  
 -RECESSED FOR SHEET PANS  
 -(4) 14GA S/S CONSTRUCTED ROLLED "V" TRAY SLIDE  
 -MOUNTED ON FOLD-DOWN BRACKETS  
 -(2) DECOR PANELS  
 -HARDWARE COLOR VERIFY  
 -NEMA NO. 5-15 PLUG W/ 9FT CORD  
 120V-60C-1PH-2.56A  
 -TO PIGGYBACK INTO UNIT AT LEFT

SKU NO. 000-40010YPV3  
 MODEL NO. SSC-50-9P1 ITEM NO. 3

-COLD PAN SERVING COUNTER  
 -39.00 BY 21.62 BY 7.00 MECH. COOLED COLD PAN WITH DRAIN  
 115V-60C-1PH-2.4A-1/2HP  
 -4" DEEP PANS BY OTHERS  
 -RECESSED FOR SHEET PANS  
 -(4) 14GA S/S CONSTRUCTED ROLLED "V" TRAY SLIDE  
 -MOUNTED ON FOLD-DOWN BRACKETS  
 -(2) DECOR PANELS  
 -HARDWARE COLOR VERIFY  
 -NEMA NO. 5-15 PLUG W/ 9FT CORD  
 120V-60C-1PH-2.56A  
 -TO PIGGYBACK INTO UNIT AT RIGHT

SKU NO. 000-40010YPV4  
 MODEL NO. SH-4-4M1 ITEM NO. 4

-HEATED SERVING COUNTER  
 -ELECTRIC LDU WATT (WET OR DRY)  
 HOT FOOD TABLE WITH DRAINS AND MANTLED  
 208-230V-60C-1PH-10.8A  
 -RECESSED FOR SHEET PANS  
 -(4) 14GA S/S CONSTRUCTED ROLLED "V" TRAY SLIDE  
 -MOUNTED ON FOLD-DOWN BRACKETS  
 -S/S CONSTRUCTED WORKSHELF  
 -MOUNTED ON FOLD-DOWN BRACKETS  
 -(2) DECOR PANELS  
 -HARDWARE COLOR VERIFY  
 -POWER POLE FOR CORD & PLUG  
 -(1) 120V-2.56A SINGLE RECEPTACLE, NEMA #5-15R  
 -PIGGYBACK FROM UNIT AT LEFT  
 -NEMA NO. 14-30 PLUG W/ 9FT CORD  
 120/208-230V-60C-1PH-16.63A

SKU NO. 000-40010YPV5  
 MODEL NO. SSC-50 ITEM NO. 5

-DUAL CASHIER COUNTER  
 -(2) 3 IN. DIAMETER HOLE WITH GROMMET IN TOP  
 -(2) S/S SHELF AND LOCKING DRAWER  
 -(2) 14GA S/S CONSTRUCTED ROLLED "V" TRAY SLIDES  
 -MOUNTED ON FOLD-DOWN BRACKETS  
 -(2) 120V-15A DUPLEX (GFCI) RECEPTACLE, NEMA #5-15R WITH 100A BREAKERS  
 -(2) DECOR PANELS  
 -HARDWARE COLOR VERIFY  
 -NEMA NO. 14-30 PLUG W/ 9FT CORD  
 120/208-230V-60C-1PH-1ØA  
 -TO PIGGYBACK INTO UNIT AT RIGHT

SKU NO. 000-40010YPV6  
 MODEL NO. SSC-50-9P1 ITEM NO. 6

-COLD PAN SERVING COUNTER  
 -39.00 BY 21.62 BY 7.00 MECH. COOLED COLD PAN WITH DRAIN  
 115V-60C-1PH-2.4A-1/2HP  
 -4" DEEP PANS BY OTHERS  
 -RECESSED FOR SHEET PANS  
 -(2) 14GA S/S CONSTRUCTED ROLLED "V" TRAY SLIDES  
 -MOUNTED ON FOLD-DOWN BRACKETS  
 -(2) DECOR PANELS  
 -HARDWARE COLOR VERIFY  
 -POWER POLE FOR CORD & PLUG  
 -(1) 120V-2.56A SINGLE RECEPTACLE, NEMA #14-50R  
 -PROVIDE WITH GFCI BREAKER  
 -PIGGYBACK FROM UNIT AT LEFT  
 -NEMA NO. 14-30 PLUG W/ 9FT CORD  
 120/208-230V-60C-1PH-16.63A

SKU NO. 000-40010YPV1  
 MODEL NO. SH-4-4M1 ITEM NO. 1

-HEATED SERVING COUNTER  
 -ELECTRIC LDU WATT (WET OR DRY)  
 HOT FOOD TABLE WITH DRAINS AND MANTLED  
 208-230V-60C-1PH-10.8A  
 -RECESSED FOR SHEET PANS  
 -(4) 14GA S/S CONSTRUCTED ROLLED "V" TRAY SLIDE  
 -MOUNTED ON FOLD-DOWN BRACKETS  
 -S/S CONSTRUCTED WORKSHELF  
 -MOUNTED ON FOLD-DOWN BRACKETS  
 -(2) DECOR PANELS  
 -HARDWARE COLOR VERIFY  
 -POWER POLE FOR CORD & PLUG  
 -(1) 120V-2.56A SINGLE RECEPTACLE, NEMA #5-15R  
 -PIGGYBACK FROM UNIT AT RIGHT  
 -NEMA NO. 14-30 PLUG W/ 9FT CORD  
 120/208-230V-60C-1PH-16.63A

SKU NO. 000-40010YPV2  
 MODEL NO. SSC-50-9P1 ITEM NO. 2

-COLD PAN SERVING COUNTER  
 -39.00 BY 21.62 BY 7.00 MECH. COOLED COLD PAN WITH DRAIN  
 115V-60C-1PH-2.4A-1/2HP  
 -4" DEEP PANS BY OTHERS  
 -RECESSED FOR SHEET PANS  
 -(4) 14GA S/S CONSTRUCTED ROLLED "V" TRAY SLIDE  
 -MOUNTED ON FOLD-DOWN BRACKETS  
 -(2) DECOR PANELS  
 -HARDWARE COLOR VERIFY  
 -NEMA NO. 5-15 PLUG W/ 9FT CORD  
 120V-60C-1PH-2.56A  
 -TO PIGGYBACK INTO UNIT AT LEFT

SKU NO. 000-40010YPV3  
 MODEL NO. SSC-50-9P1 ITEM NO. 3

-COLD PAN SERVING COUNTER  
 -39.00 BY 21.62 BY 7.00 MECH. COOLED COLD PAN WITH DRAIN  
 115V-60C-1PH-2.4A-1/2HP  
 -4" DEEP PANS BY OTHERS  
 -RECESSED FOR SHEET PANS  
 -(4) 14GA S/S CONSTRUCTED ROLLED "V" TRAY SLIDE  
 -MOUNTED ON FOLD-DOWN BRACKETS  
 -(2) DECOR PANELS  
 -HARDWARE COLOR VERIFY  
 -NEMA NO. 5-15 PLUG W/ 9FT CORD  
 120V-60C-1PH-2.56A  
 -TO PIGGYBACK INTO UNIT AT RIGHT

SKU NO. 000-40010YPV4  
 MODEL NO. SH-4-4M1 ITEM NO. 4

-HEATED SERVING COUNTER  
 -ELECTRIC LDU WATT (WET OR DRY)  
 HOT FOOD TABLE WITH DRAINS AND MANTLED  
 208-230V-60C-1PH-10.8A  
 -RECESSED FOR SHEET PANS  
 -(4) 14GA S/S CONSTRUCTED ROLLED "V" TRAY SLIDE  
 -MOUNTED ON FOLD-DOWN BRACKETS  
 -S/S CONSTRUCTED WORKSHELF  
 -MOUNTED ON FOLD-DOWN BRACKETS  
 -(2) DECOR PANELS  
 -HARDWARE COLOR VERIFY  
 -POWER POLE FOR CORD & PLUG  
 -(1) 120V-2.56A SINGLE RECEPTACLE, NEMA #5-15R  
 -PIGGYBACK FROM UNIT AT LEFT  
 -NEMA NO. 14-30 PLUG W/ 9FT CORD  
 120/208-230V-60C-1PH-16.63A

SKU NO. 000-40010YPV5  
 MODEL NO. SSC-50 ITEM NO. 5

-DUAL CASHIER COUNTER  
 -(2) 3 IN. DIAMETER HOLE WITH GROMMET IN TOP  
 -(2) S/S SHELF AND LOCKING DRAWER  
 -(2) 14GA S/S CONSTRUCTED ROLLED "V" TRAY SLIDES  
 -MOUNTED ON FOLD-DOWN BRACKETS  
 -(2) 120V-15A DUPLEX (GFCI) RECEPTACLE, NEMA #5-15R WITH 100A BREAKERS  
 -(2) DECOR PANELS  
 -HARDWARE COLOR VERIFY  
 -NEMA NO. 14-30 PLUG W/ 9FT CORD  
 120/208-230V-60C-1PH-1ØA  
 -TO PIGGYBACK INTO UNIT AT RIGHT

SKU NO. 000-40010YPV6  
 MODEL NO. SSC-50-9P1 ITEM NO. 6

-COLD PAN SERVING COUNTER  
 -39.00 BY 21.62 BY 7.00 MECH. COOLED COLD PAN WITH DRAIN  
 115V-60C-1PH-2.4A-1/2HP  
 -4" DEEP PANS BY OTHERS  
 -RECESSED FOR SHEET PANS  
 -(2) 14GA S/S CONSTRUCTED ROLLED "V" TRAY SLIDES  
 -MOUNTED ON FOLD-DOWN BRACKETS  
 -(2) DECOR PANELS  
 -HARDWARE COLOR VERIFY  
 -POWER POLE FOR CORD & PLUG  
 -(1) 120V-2.56A SINGLE RECEPTACLE, NEMA #14-50R  
 -PROVIDE WITH GFCI BREAKER  
 -PIGGYBACK FROM UNIT AT LEFT  
 -NEMA NO. 14-30 PLUG W/ 9FT CORD  
 120/208-230V-60C-1PH-16.63A

JOB NAME: EAST ROBERTSON HS  
 DEALER:  
 DRAWN BY: CL  
 APPROVED BY: K. KREINER  
 DATE: 1/18/19  
 SCALE: 1/2" = 1'-0"

1724611\_001A

DELFIELD®  
 A Weibull Brand

980 S. ISABELLA RD.  
 MT. PLEASANT, MI 48858  
 (989) 773-7981 • 800-233-8821

THIS DRAWING IS THE PROPERTY OF DELFIELD. IT IS TO BE USED ONLY FOR THE PROJECT AND SITE SPECIFICALLY IDENTIFIED HEREIN. THE EXPRESS WRITTEN CONSENT OF DELFIELD.