

John D. Tigert
Purchasing Services Manager

Kenneth F. Waggoner Building
201 Johnston Street, 2nd Floor
Saint George, SC 29477
Telephone: 843.563.0142
Fax No. : 843.563.0152



Request for Quotes
No. 2021-67

Security Fencing at Three Dorchester County
Pump Stations

PROJECT OVERVIEW (See Scope of Work for details)

SOLICITATION NUMBER:

RFQ No. 2021-67

DESCRIPTION OF SERVICES:

Provision and Installation of Security Fencing at
Three Dorchester County Pump Stations

DEADLINE FOR QUOTE SUBMISSION:

06/21/2021 @ 5:00 PM

QUOTES SHOULD BE EMAILED TO:

John Tigert

jtigert@dorchestercountysc.gov

OR SUBMITTED ONLINE THROUGH ELECTRONIC SOLICITATION AT

<https://vrapp.vendorregistry.com/Bids/View/BidsList?BuyerId=e18973c1-4a13-4b63-a74f-fee9c6a670c0>

SPECIFICATIONS

Scope of Work

The contractor shall furnish all labor, tools, materials, equipment and supervision necessary to provide and install commercial grade security and 98% Approximately Privacy fencing for Dorchester County Water and Sewer at three (3) site locations, in the areas indicated on the attached drawings. The project scope includes the following:

1. Locate and mark any underground utilities prior to the installation and/or demolition of fencing.
2. Remove and properly dispose of the existing fence.
3. Provide and install 96" (8') height black PVC coated commercial grade chain link fence with black vinyl privacy slats. Must meet 98% approximate privacy factor. Leave approximately 2" between bottom of fence and surface grade.
4. The entire length of fence shall have a minimum of 9 Gauge Black PVC coated tension wire at the bottom of fence.
5. The fence shall have at a minimum 1 5/8" Diameter Schedule 40 steel black PVC coated for commercial and industrial applications top pole and brace rails. Brace Rails shall be used throughout the entire fence run.
6. Fence line posts shall be a minimum 2 1/2" Diameter steel black PVC coated for commercial and industrial use. Line posts shall be spaced 10' on center and installed at a minimum depth of 36" and secured with 3000PSI concrete at a minimum of four times the pole diameter in width.
7. Each location shall have one 4' pedestrian gate and one 20' double drive through gate meeting the same requirements from line 3. Both the 4' pedestrian gate and the 20' drive thru gate shall have provisions to accommodate keyed pad locks.
8. Gate posts shall be at a minimum 6" in diameter steel Black PVC coated for commercial and industrial use.
9. Each fence shall have 1' of vertical Black PVC coated class 2a steel wire double strand Barbed wire with 4-point barbs (without PVC finish on 4-point barbs).
10. Barbed wire supporting arms shall be Black PVC coated and vertical with provisions to attach 3-rows of barbed wire.
11. Install chain link fence in accordance with ASTM and manufacturer's instructions.
12. Obtain a business license from Dorchester County.
13. Ensure finished work meets county's approval.
14. Provide final cleaning after completion of work.
15. Any change orders not in the scope or agreed upon prior to work beginning must be approved before it is started.
16. All work must meet all required code standards.
17. Fence locations shall remain secure and no more than seven days shall pass once the old fence is removed and the new is installed.

Location of Work

Work will be performed at the following locations:

Pump Station #56
1871 Central Avenue/Myers Mill Subdivision
Summerville, SC

Pump Station #57
5097 Blair Road/Myers Mill Subdivision
Summerville, SC

Pump Station #93
Towering Pine Drive/Summerhaven
Summerville, SC

Contractors may visit the site locations to measure as necessary.

Pricing

Contractor should provide lump-sum pricing for the work on a quote on company letterhead.

Payment

Contractor shall invoice Dorchester County after completion of project. Payment will be made within thirty (30) days from the date of invoice approval.

Notification

The contractor will provide notification to Dorchester County of any accidents, injuries, or complaints by the public to allow the department to investigate these matters.

Time of Completion

The Contractor shall commence work upon a Notice to Proceed, in the form of a purchase order, from the County and work must be completed within 30 days unless otherwise ordered by the County.

Business Licensing

The Contractor must possess a valid business license in each jurisdiction.

Damage of Property

Any damage to Dorchester County property or private property as a result of the Contractor's operation shall be immediately repaired by the Contractor. Should the repair not be instituted soon enough, or satisfactorily in the opinion of Dorchester County, County reserves the right to make the necessary repairs and deduct these costs from any monies due the Contractor. The Contractor shall rent equipment as needed to cover any equipment breakdowns.

Award

The lowest quote that meets all requirements, as verified by the County's Director of Water & Sewer, will be issued a purchase order that represents a contract between the County and the

vendor.

Acceptance of the purchase order by the vendor indicates acceptance of these RFQ terms and conditions as the contractual terms and conditions of this purchase.

**REQUEST FOR QUOTES (RFQ)
GENERAL TERMS AND CONDITIONS**

1. PREPARATION, SUBMISSION AND WITHDRAWAL OF QUOTES

- A. This solicitation is being issued in accordance with the Dorchester County Procurement Policies. All proposers, and all associated sub-consultants as deemed necessary, shall be able to be properly licensed to conduct its business in Dorchester County, with all licenses, permits, and certificates as required by all local, State of South Carolina, and Federal agencies.
- B. Quotes may be electronically submitted via the Vendor Registry website; however, Dorchester County is not responsible if submissions are not received due to website errors.
- C. **Quotes submitted after the due date and time are considered “Late Quotes,” and will not be opened or considered.**
- D. Quotes may be withdrawn by written request received from the Contractor prior to the time set for opening of quotes, but not thereafter.
- E. Dorchester County reserves the right to make any changes to this RFQ, or to reject any and all quotes, or parts of any and all quotes or to accept any quote or portion thereof deemed to be in the best interest of the County, or postpone or cancel, at any time, this RFQ, or to re-solicit this RFQ, or to waive any irregularities in this RFQ or in the quotes received as a result to this RFQ. Dorchester County also reserves the right to request clarification or information from any proposer. The County is not liable for any expenses incurred by any firm as a result of being a respondent to this solicitation.
- F. Any interpretation, correction or change of the RFQ documents will be made by addendum.
It is your responsibility to monitor the Procurement website by selecting Quotes/RFQ Opportunities at www.dorchestercountysc.gov for any additional information, revisions, or addenda that may be posted.
- G. No substitutions will be considered after the Contract award except by amendment or change order.

2. CONTRACTOR REPRESENTATIONS

Each Contractor by submitting a quote represents that:

- A. The Contractor has read and understands this RFQ (including all specifications, attachments, and addenda) and that their quote is made in accordance therewith.
- B. The Contractor has reviewed the RFQ, has become familiar with the local conditions under which the Work is to be performed, and has correlated personal observations with the requirements of the proposed Contract Documents.
- C. The quote is based on the terms, materials, systems and equipment required by this RFQ, without exception.

- D. The Contractor is qualified to provide the services and equipment required under this RFQ and, if awarded the Contract, will do so in a professional, timely manner using Contractor's best skill and attention.

3. **AWARD OF CONTRACT**

- A. The contract will be awarded to the most responsive and responsible firm meeting the specifications of the County. Although cost will be a consideration, the award will be based on cost, consistent with the desired quality of service needed for effective use.
- B. The County reserves the right to 1) reject any or all quotes and any part of a quote; 2) waive informalities, technical defects, and minor irregularities in quotes received.
- C. The County shall be the sole judge of the suitability of the items or services to be provided pursuant to this RFQ.

4. **INDEMNIFICATION**

Except for expenses or liabilities arising from the negligence or intentional acts of the County, the Contractor hereby expressly agrees to indemnify and hold the County harmless against any and all expenses and liabilities arising out of the negligent performance, action or inaction of the Contractor in conduct of this Contract, as follows:

For matters other than those arising from the rendering or failure to render professional services, the Contractor expressly agrees to the extent that there is a causal relationship between its negligence, action or inaction, or the negligence, action or inaction of any of its employees or any person, firm or corporation directly or indirectly employed by the Contractor and any damage, liability, injury, loss or expense (whether in connection with bodily injury or death or property damage) that is suffered by the County and/or its officers or employees or by any member of the public, to indemnify and save the County and its officers and employees harmless against any and all liabilities, penalties, demands, claims, lawsuits, losses, damages, costs, and expenses arising out of the negligence, action or inaction of the Contractor, regardless of whether such liabilities, penalties, demands, claims, lawsuits, losses, damages, costs and expenses are caused in part by the County. Such costs are to include, without limitation, defense, settlement and reasonable attorney's fees incurred by the County and its employees. This promise to indemnify shall include, without limitation, bodily injuries or death occurring to the Contractor's employees and any person, directly or indirectly employed by the Contractor (including, without limitation, any employee of any subcontractor), the County's officers or employees, the employees of any other independent contractors, or occurring to any member of the public. When the County submits notice, the Contractor shall promptly defend any aforementioned action.

For matters arising out of the rendering or failure to render professional services, the Contractor will indemnify and save the County and its officers and employees harmless from and against all liabilities, penalties, demands, claims, lawsuits, losses, damages, costs and expenses arising out of or resultant from any negligent act, error or omission of the Contractor in the rendering or failure to render professional services under this Contract. Such costs are

to include, without limitation, defense, settlement and reasonable attorneys' fees incurred by the County and its officers and employees. This promise to indemnify shall include, without limitation, bodily injuries or death occurring to the Contractor's employees and any person, directly or indirectly employed by the Contractor (including, without limitation, any employee of any subcontractor), the County's officers or employees, the employees of any other independent contractors, or occurring to any member of the public. When the County submits notice of claim that triggers the indemnity, the Contractor shall promptly defend any afore mentioned action at its own cost.

The limits of insurance required in this Contract shall not limit the Contractor's obligations under this Section. The terms and conditions contained in this Section shall survive the termination of the Contract or the suspension of the Work hereunder. To the extent that any liabilities, penalties, demands, claims, lawsuits, losses, damages, costs and expenses are caused in part by the acts of the County, the Contractor's obligations shall be reduced in proportion to the County's fault. The obligations herein shall also extend to any actions by the County to enforce this indemnity obligation. The recovery of costs and fees all extend to those incurred in the enforcement of this indemnity.

5. STATE AND LOCAL TAXES

Except as otherwise provided, Quotes shall *include* all applicable state and local taxes.

The successful Contractor shall calculate that portion of the Contract which is subject to the seven percent (7%) sales and/or use tax, which amount shall be itemized and shown on all invoices and shall be paid to South Carolina Department of Revenue (SCDOR) by Contractor. If the successful Contractor is a non-South Carolina company, the County will withhold said amount from all invoices and remit payment to the SCDOR, unless the Contractor furnishes County with a valid South Carolina Use Tax Registration Certificate Number.

The successful Contractor shall indemnify and hold harmless the County for any loss, cost, or expense incurred by, levied upon or billed to the County as a result of the successful Contractor's failure to pay any tax of any type due in connection with this Contract.

The successful Contractor shall ensure that the above sections are included in all subcontracts and sub-contracts and shall ensure withholding on out of state sub and sub-subcontractors to which withholding is applicable.

6. DRUG-FREE WORKPLACE ACT

By submitting a quote, Contractor certifies that, if awarded a contract, Contractor will comply with all applicable provisions of the Drug-Free Workplace Act, Title 44, Chapter 107 of the South Carolina Code of Laws, as amended.

7. INSURANCE REQUIREMENTS

The successful Contractor shall procure, maintain, and provide proof of, insurance coverage for injuries to persons and/or property damage as may arise from or in conjunction with, the work performed on behalf of the County by the Contractor, his agents, representatives, employees or subcontractors.

A. Coverage Provisions

- a. All deductibles or self-insured retention shall appear on the certificate(s).
- b. The County of Dorchester, its' officers/ officials, employees, agents and volunteers shall be added as "additional insured" as their interests may appear. This provision does not apply to Professional Liability or Workers' Compensation/Employers' Liability.
- c. The Contractor's insurance shall be primary over any applicable insurance or self-insurance maintained by the County.
- d. Shall provide 30 days written notice to the County before any cancellation, suspension, or void of coverage in whole or part, where such provision is reasonable.
- e. All coverage for subcontractors of the Contractor shall be subject to allos the requirements stated herein.
- f. All deductibles or self-insured retention shall appear on the certificate(s) and shall be subject to approval by the County. At the option of the County, either; the insurer shall reduce or eliminate such deductible or self-insured retention; or the Contractor shall be required to procure a bond guaranteeing payment of losses and related claims expenses.
- g. Failure to comply with any reporting provisions of the policy(s) shall not affect coverage provided the County, its officers/officials, agents, employees and volunteers.
- h. The insurer shall agree to waive all rights of subrogation against the County, its' officers/officials, agents, employees or volunteers for any act, omission or condition of premises which the parties may be held liable by reason of negligence.

The Contractor shall furnish the County certificates of insurance including endorsements affecting coverage. The certificates are to be signed by a person authorized by the insurance company(s) to bind coverage on its' behalf, if executed by a broker, notarized copy of authorization to bind, or certify coverage must be attached.

8. INSPECTION

The purchased services shall be subject to inspection and testing by the County. The Contractor shall, without charge, correct any workmanship found by the County not to conform to the RFQ requirements.

Attachment 1 - Drawings

- NOTE:**
- ALL CHAIN LINK SHALL BE BLACK PVC COATED WITH BLACK VINYL SLATS (98% APPROXIMATE PRIVACY)
 - ALL POSTS, PIPE RAILS AND APPURTENANCES SHALL BE BLACK PVC COATED TO MATCH CHAIN LINK.
 - ALL GATE POSTS 6" MIN. DIAMETER.
 - TOP AND BRACE RAILS SHOULD BE USED THROUGHOUT.
 - ALL CHAIN LINK FENCING SHALL HAVE RECOMMENDED TIES AND BRACING TO ACCOMMODATE 98% APPROXIMATE PRIVACY.

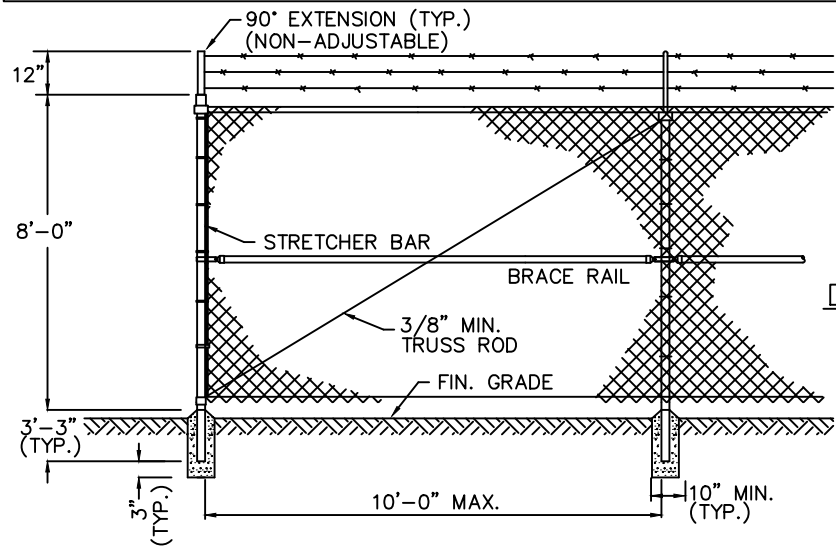

DETAIL
TYPICAL FENCE CORNER

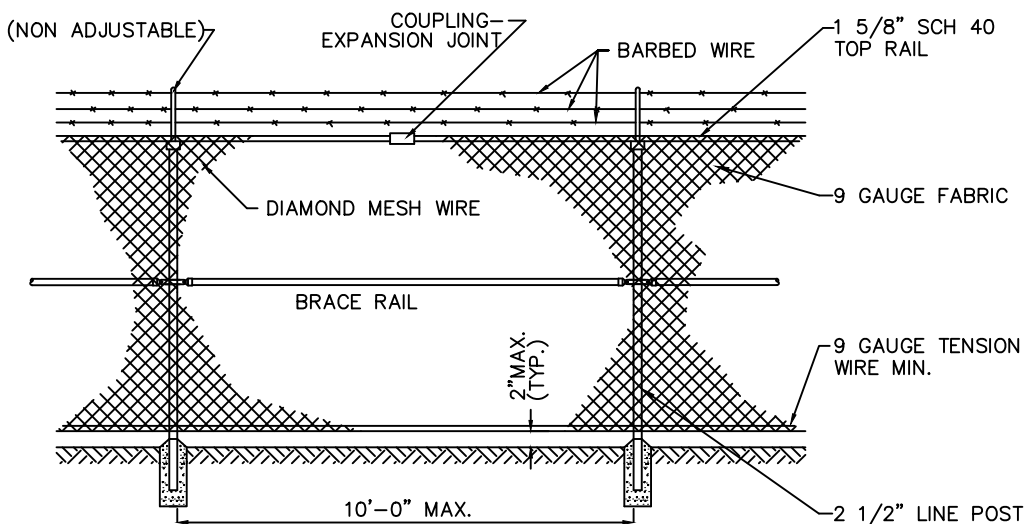

DETAIL
FENCE LINE SPAN

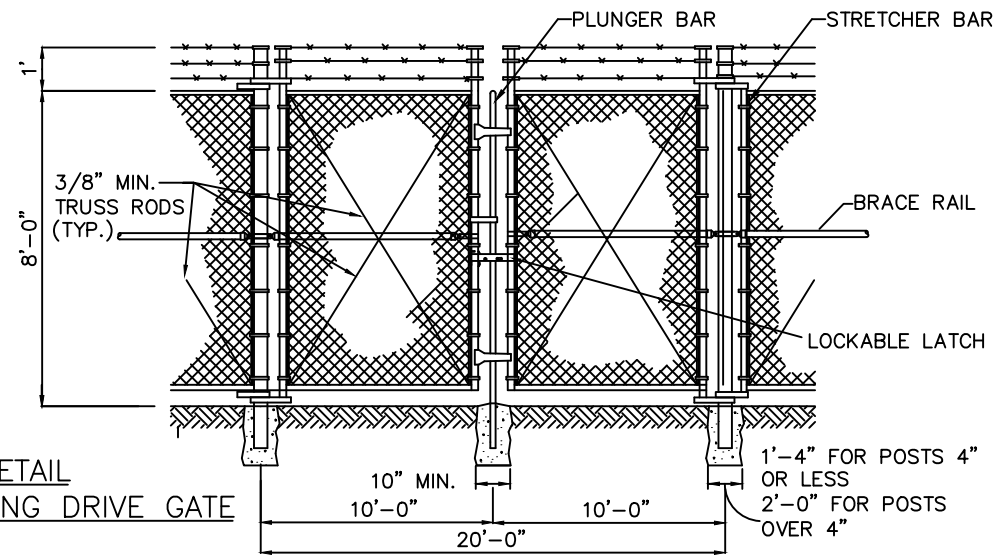

DETAIL
DOUBLE SWING DRIVE GATE

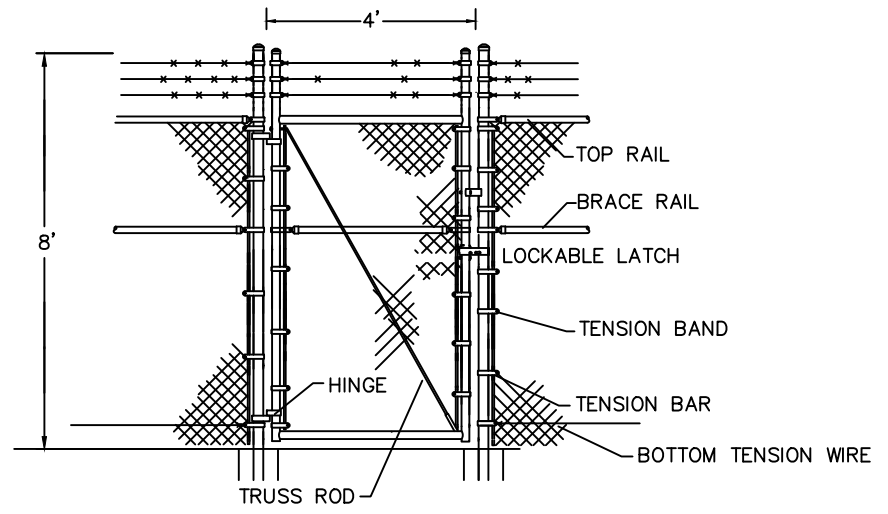

DETAIL
PEDESTRIAN GATE

| | |
|---|-----------------------------|
| DORCHESTER COUNTY WATER & SEWER | |
| TYPICAL PUMP STATION CHAIN LINK FENCE DETAIL | DRAWING: S-14 |
| DATE: <u> JUNE 2021 </u> | DRAWN BY: <u> STL </u> |
| SCALE: <u> NTS </u> | APPROVED BY: <u> JDC </u> |

FENCE REPLACEMENT PS 56
1871 CENTRAL AVENUE
MYERS MILL SUBDIVISION
SUMMERVILLE



CENTRAL AVENUE
(R/W VARIES)

MYERS MILL HOMEOWNERS
ASSOCIATION INC (POOL)

FENCE APPROXIMATELY 1'
INSIDE PROPERTY LINE

PS 56

20' DOUBLE GATE

4' MAN GATE

MYERS MILL HOMEOWNERS
ASSOCIATION INC (POOL)

**NOTE: FENCE DIMENSIONS SHOWN ARE APPROXIMATE.
CONTRACTOR TO VERIFY ACTUAL DIMENSIONS**

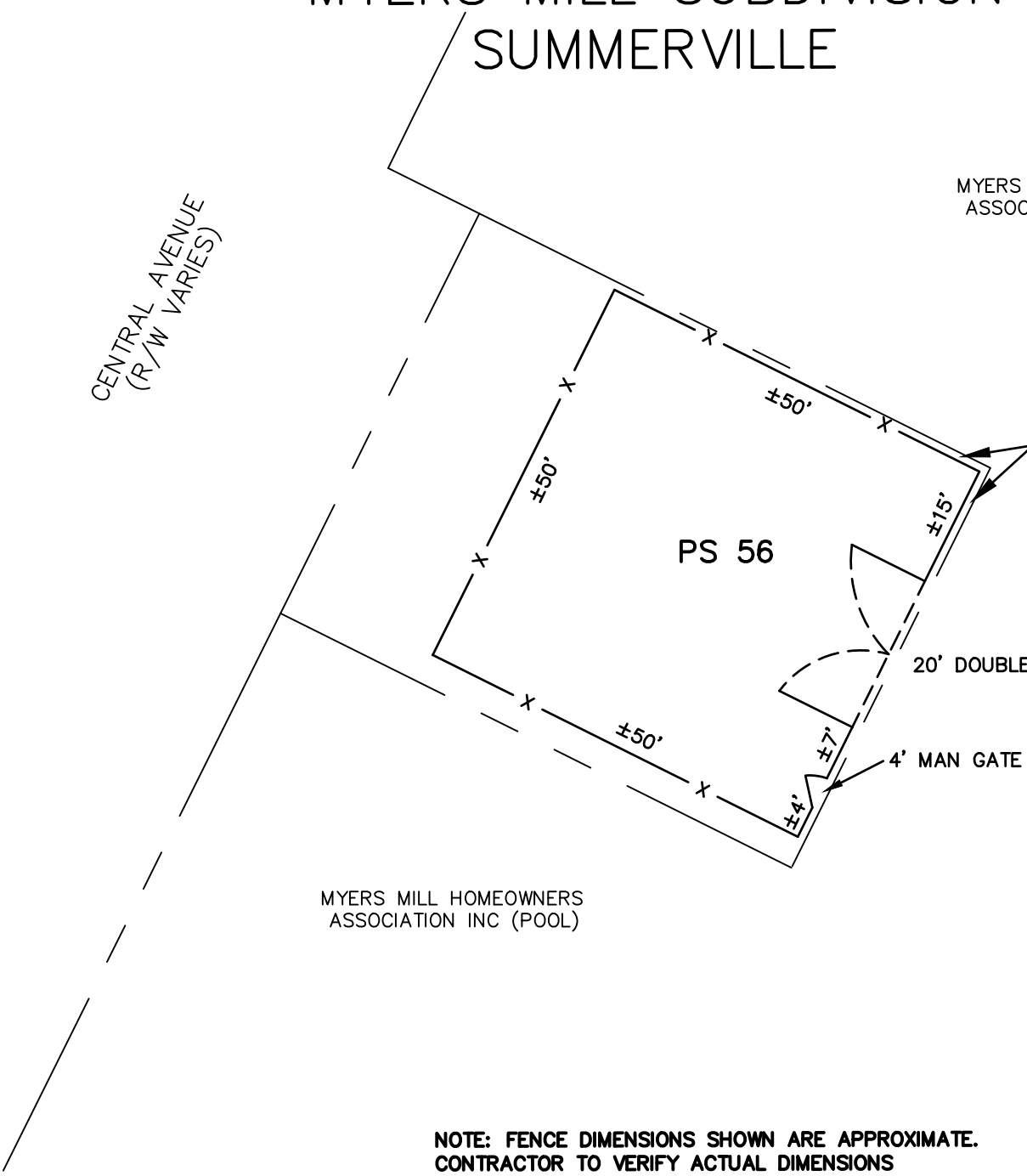

FENCE REPLACEMENT PS 57
5097 BLAIR ROAD
MYERS MILL SUBDIVISION
SUMMERVILLE

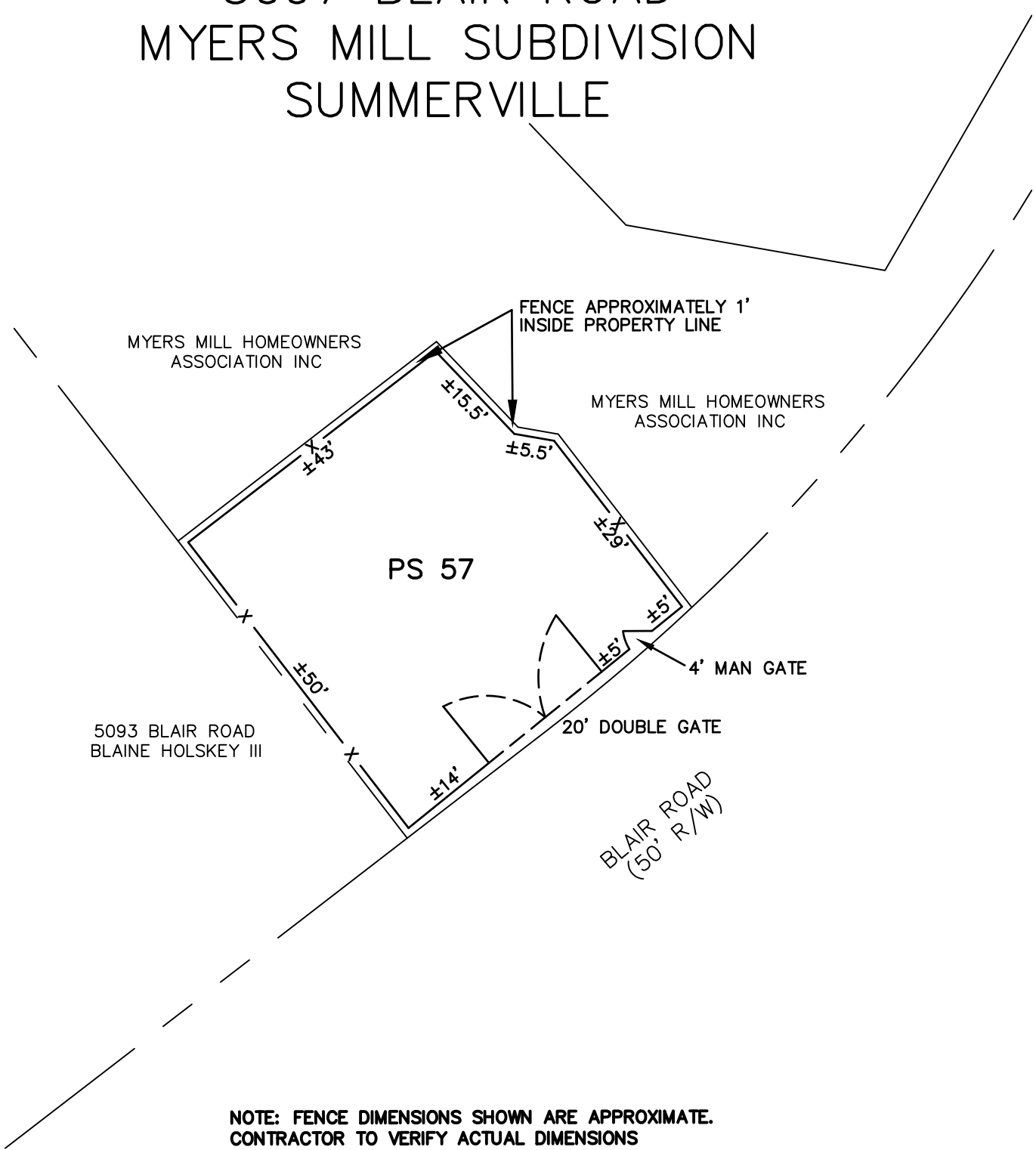

NOTE: FENCE DIMENSIONS SHOWN ARE APPROXIMATE.
CONTRACTOR TO VERIFY ACTUAL DIMENSIONS

FENCE REPLACEMENT PS 93 TOWERING PINE DRIVE SUMMERHAVEN SUMMERVILLE



204 TOWERING PINE DRIVE

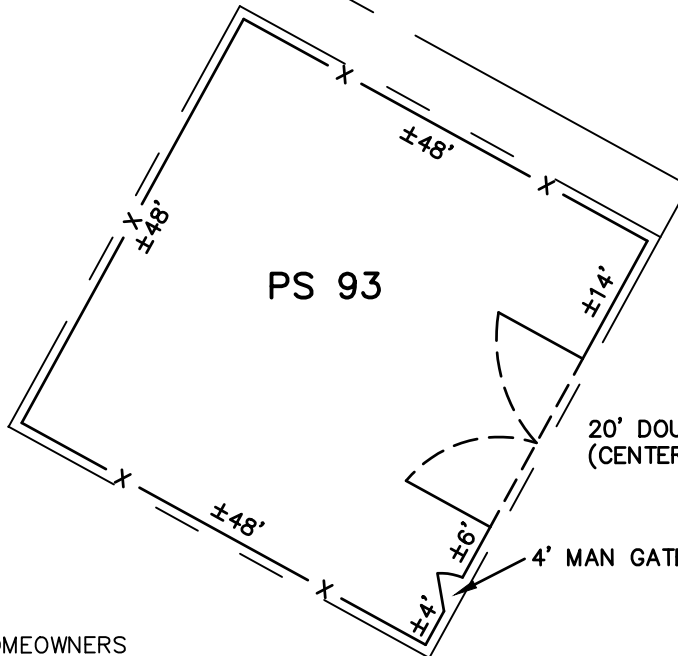

FENCE APPROXIMATELY 1'
INSIDE PROPERTY LINE

20' DOUBLE GATE
(CENTER GATE ON DRIVEWAY)

4' MAN GATE

TOWERING PINE DRIVE
(50' R/W)

SUMMERHAVEN HOMEOWNERS
ASSOCIATION INC (POND)

**NOTE: FENCE DIMENSIONS SHOWN ARE APPROXIMATE.
CONTRACTOR TO VERIFY ACTUAL DIMENSIONS**