

**EFFINGHAM COUNTY, GEORGIA
REQUEST FOR QUOTE
RFQ NO. 19-25-005**

QUOTATION FOR : One (1) New Wheeled Excavator

**EFFINGHAM COUNTY PURCHASING AGENT
601 N. LAUREL STREET
SPRINGFIELD, GEORGIA 31329
(912) 754-2159 (PHONE)
(912) 754-8413 (FAX)
fcharleton@effinghamcounty.org**

**DATE ISSUED: February 26, 2019
DATE DUE: March 18, 2019
TIME DUE: 11.00am (local time)
DEPT. FOR: Public Works**

NOTE: Each Vendor or Contractor submitting a response to this request will be responsible for providing any or all of the items or services listed below, **as described** upon receipt of an Effingham County Contract for such items or service. “Effingham County is an Equal Opportunity Employer”, M/F/H, all vendors are required to be Equal Opportunity Employers M/F/H.

GENERAL INFORMATION:

The purpose of this proposal is to solicit written quotations for one (1) new wheeled excavator for Effingham County Board of Commissioners. Equipment will be new and never titled. **ALL QUOTES SHOULD BE CONTAINED IN A SEALED OPAQUE ENVELOPE, CLEARLY MARKED “SEALED BID 19-25-003” AND WILL BE PUBLICLY OPENED AND READ ALOUD AT 11.00am (ET) Monday March 18, 2019. AT THE ADMINISTRATIVE COMPLEX AT THE ADDRESS LISTED ABOVE.**

Effingham County Board of Commissioners reserves the right to reject any and all bids or any and all bids that are non-responsive or not responsible. Additionally, Effingham County Board of Commissioners has the right to waive any technicalities or informalities. Effingham County may issue change orders altering the original scope of work to address changes or unforeseen conditions necessary for the project completion.

Effingham County Board of Commissioners also reserves the right to make minor changes or further negotiate details and terms. Once the quote is accepted and terms are set, if the vendor fails to deliver within the agreed upon time Effingham County reserves the right to accept a quote from another vendor. Effingham County has the option of selecting more than one vendor for the services outlined in this RFQ.

1.0 BILLING/INVOICES: All invoices are to be mailed to:

*Effingham County Finance Department
601 North Laurel Street
Springfield, GA 31329*

2.0 BID RECIPIENT: This bid is submitted to :

*Effingham County Board of Commissioners
601 North Laurel Street
Springfield, GA 31329*

3.0 DELIVERY: Delivery will be made to :

*Effingham County Board of Commissioners – Public Works
309 Highway 119 South
Springfield, GA 31329*

At least one day advance notice will need to be made prior to delivery. All items shall be delivered F.O.B. destination and delivery costs and charges included in the bid.

Effingham County will be responsible for applying for all Georgia tags and titles.

NOTE: assign title to Effingham County Board of Commissioners, 601 N Laurel Street, Springfield, GA 31329.

Upon delivery, vehicle will have dealer drive out tags, and complete certification of origin, warranty, owner's manual and any other necessary credentials.

Vehicle will be delivered with not less than a half a tank of fuel.

- 4.0 **BIDDER'S ACKNOWLEDGEMENTS:** Bidder accepts all of the terms and conditions of the Instructions to Bidders. This Bid will remain subject to acceptance for 60 days after the Bid opening, or for such longer period of time that Bidder may agree to in writing upon request of Owner.
- 5.0 **BIDDER'S REPRESENTATIONS:** In submitting this Bid, Bidder represents that Bidder has examined and carefully studied the Bidding Documents and other related data identified in the Bidding Documents.
- 6.0 **BASIS OF BID:** Bidder acknowledges that estimated quantities are not guaranteed and are solely for the purpose of comparison of Bids, and final payment for all unit price Bid items will be based on actual quantities, as determined in the Purchase Order or Contract Documents.
- 7.0 **QUESTIONS:** Any questions pertaining to the bid **must** be made in writing and must be received at the office of the Purchasing Agent no later than **2.00pm (ET) Friday March 8, 2019.** No response will be given to any questions received after **2.00pm (ET) Friday March 8, 2019.**

Questions may be faxed to 912-754-8413; emailed to fcharleton@effinghamcounty.org or hand delivered/mailed to Effingham County Board of Commissioners, Purchasing Office, 601 N Laurel Street, Springfield, GA 31329. The response to all questions will be in the form of an addendum and will be posted on the Effingham County website www.effinghamcounty.org before **5.00pm (ET) Wednesday March 13, 2019.** If hand delivering or mailing questions, please DO NOT mark the outside of the envelope with the bid number.

The only official answer or position of Effingham County will be the one stated in writing.

INTENTIONALLY LEFT BLANK

SPECIFICATIONS

Brand name is listed below for comparison purposes only - quote must meet or exceed the specifications of the item listed

SPECIFICATIONS:

The County wishes to purchase a new wheeled excavator, equal to or better than the John Deere 190G W (full specifications attached at the end of this RFQ), with 2 piece boom, front blade and rear outriggers and the following (required) options:

General purpose bucket
Ditching bucket
Grappler
60" Cutterhead
Automatic quick coupler
Protective package for cutter head

Please list extended warranty options on the quote sheet. Standard warranty to be included.

The County has the following pieces of equipment it would like to trade-in – please list trade-in price on the quote sheet :

2000 Gradall XL4100 front engine hours 4448, rear engine hours 5664, and rear engine inoperable

2007 Gradall 5100XL engine hours 39016 and unit is operable

The Gradall's are located in Springfield, GA.

To view the Gradall's, please call Jay Beasley on 912-445-1891.

If bidder is quoting a different make and model, full specification sheets for the quoted make and model must be included with bid packet.

INTENTIONALLY LEFT BLANK

RFQ No. 19-25-005

One (1) New Wheeled Excavator

QUOTE

Description	Manufacturers name and Model No.	Bid Price
One (1) new wheeled excavator with 2 piece boom, front blade and rear outriggers, general purpose bucket, ditching bucket, grappler, 60” cutter head, automatic quick coupler, protective package for cutter head.		\$

Time required for delivery after receipt of order _____ / Days
 (Award may be contingent on delivery)

Item Description	Trade-in Offered
2000 Gradall XL4100 font engine hours 4448, rear engine hours 5664, and rear engine inoperable	\$
2007 Gradall 5100XL engine hours 39016 and unit is operable	\$

Extended Warranty Options available:

QUOTE (page 2)

Proposing Company Contact Information:

Company Name:		
Billing Address:		Telephone:
Service Address:		Telephone:
Representative Name:		
Representative Contact Address:		Telephone: E-Mail:

It is agreed by the undersigned offeror that the signature and submission of this proposal represents the vendor's acceptance of all terms, conditions and requirements of specifications and, if awarded, the proposal will become part of the contract agreement between the parties.

Signed: (sign manually, in ink) _____
(Signature of Authorized Representative of the Company)

Name Printed: _____ Title: _____ Date: _____

The following forms must be submitted along with the quote:

- **COPY OF THE BUSINESSES W-9**
- **COPY OF THE BUSINESS LICENSE**
- **CERTIFICATE OF INSURANCE**

Note: Quotes not fully completed will be considered incomplete and may be rejected

EXCEPTION SHEET

If Commodity(s) and/or Service proposed in quote is in ANYWAY different from that contained in this proposal, the Bidder is responsible for clearly identifying all such differences in the space below. Otherwise, it will be assumed that the Bidder's offer is in total compliance with all aspects of the proposal.

Below are the only differences between my offer and the County's proposal:

DATE

SIGNATURE/TITLE

COMPANY

Legal Notice

RFQ No. 19-25-003 – One (1) New Wheeled Excavator

Effingham County, Georgia is soliciting bids to purchase one (1) new wheeled excavator.

Sealed bids are due by **11.00am (ET) Monday March 18, 2019** and must be mailed or hand delivered to the Effingham County Purchasing Office, 601 N. Laurel Street, Springfield, GA 31329.

A copy of this Request for Quote is available at the address listed above or online at www.effinghamcounty.org - Purchasing tab. For additional information please contact, Fiona Charleton at (912) 754-2159 ext 4572 or via email: fcharleton@effinghamcounty.org

EFFINGHAM COUNTY RESERVES THE RIGHT TO REJECT ANY/AND ALL PROPOSALS AND TO WAIVE ALL FORMALITIES. "EFFINGHAM COUNTY IS AN EQUAL OPPORTUNITY EMPLOYER, M/F/H, ALL VENDORS ARE TO BE EQUAL OPPORTUNITY EMPLOYERS".

**EFFINGHAM COUNTY, GEORGIA
DOCUMENT CHECK LIST**

The following documents, when marked, are contained in and made a part of this Bid Package or are required to be submitted with the Bid. It is the responsibility of the Bidder to read, complete and sign, where indicated, and return these documents with his/her bid. FAILURE TO DO SO MAY BE CAUSE FOR DISQUALIFYING THE BID.

Company Name : _____

REQUIRED	COMPLETED	ITEM DESCRIPTION
		INSTRUCTIONS TO BIDDERS
		REQUEST FOR QUOTE
X		BID / QUOTE SUBMITTAL FORM
		SURETY REQUIREMENTS (Certified check or other security of _% required with BID SUBMITTAL – BID BOND FORM PROVIDED)
		PERFORMANCE BOND- UPON AWARD OF CONTRACT <i>(if applicable)</i>
		PAYMENT BOND- UPON AWARD OF CONTRACT <i>(if applicable)</i>
X		CERTIFICATE OF INSURANCE (SAMPLE ATTACHED)
X		W-9
		LEGAL NOTICE
X		CONTRACTOR AFFIDAVIT & AGREEMENT (E-VERIFY)
X		SUB-CONTRACTOR AFFIDAVIT & AGREEMENT (E-VERIFY) <i>(if applicable- before any subcontractor work is performed)</i>
		GEORGIA PROFESSIONAL LICENCE CERTIFICATIONS
		LIST OF SUB-CONTRACTORS <i>(if applicable)</i>
X		ATTACHMENTS
		COPY OF LLC CERTIFICATE OF ORGANIZATION AND OPERATING AGREEMENT OR COPY OF INC. CERTIFICATE OF INCORPORATION AND CORPORATE RESOLUTION DESIGNATING OFFICERS WITH AUTHORITY TO SUBMIT BID AND SIGN CONTRACT
X		RECEIPT OF ADDENDA IF ANY

Authorized Signature

Title

Print Name

Date

THIS SHEET MUST BE INCLUDED WITH BID PACKET

INSTRUCTIONS TO BIDDERS

1.1 Purpose: The purpose of this document is to provide general and specific information for use in submitting a Bid or Proposal to supply Effingham County with equipment, supplies and/or services as described herein. All bids / proposals are governed by the Code of Effingham County, and the laws of the State of Georgia.

1.2 How to Prepare Bid Proposals: All bid proposals shall be submitted on the form enclosed herewith, unless otherwise prescribed, and all documents must be submitted

All bid proposals shall be typewritten or completed with pen and ink, signed by the business owner or authorized representative, with all erasures or corrections initialed and dated by the official signing the bid / proposal. **All signature spaces must be signed.**

Bidders are encouraged to review carefully all provisions and attachments of this document prior to submission. Each bid constitutes an offer and may not be withdrawn except as provided herein.

1.3 How to Submit Bid Proposals: All bid proposals shall be:

A. Submitted in sealed opaque envelopes, plainly marked with the bid number, bid title, bid closing date, and company name.

B. Mailed or delivered as follows in sufficient time to ensure receipt by the Purchasing Agent on or before the time and date specified above.

- **Mailing Address: Effingham County Purchasing Agent, 601 North Laurel Street, Springfield, Georgia, 31329.**
- **Hand Delivery: Effingham County Purchasing Agent, 601 North Laurel Street, Springfield, Georgia, 31329.**

Please check the County's website www.effinghamcounty.org prior to submission for any addendum to the RFQ

BIDS NOT RECEIVED BY THE TIME AND DATE SPECIFIED WILL NOT BE OPENED OR CONSIDERED.

1.4 How to Submit an Objection: Objections from Bidders to this request for quote and/or these specifications should be brought to the attention of the County Purchasing Agent in writing. The objections contemplated may pertain to form and/or substance of the request for quote documents. Failure to object in accordance with the above procedure will constitute a waiver on the part of the business to protest this request for quote.

1.5 Failure to Bid: If a Bid is not submitted, the business should return this request for quote completing Attachment G, stating the reason therefore, and indicate whether the business should be retained or removed from the County's Bidders list.

1.6 Errors in Bids: Bidders or their authorized representatives are expected to fully inform themselves as to the conditions, requirements, and specifications before submitting Bids. Failure to do so will be at the Bidder's own risk. In case of error in extension of prices in the bid, the unit price will govern

1.7 Standards for Acceptance of Bid for Contract Award: The County reserves the right to reject any or all Bids and to waive any irregularities or technicalities in Bids received whenever such rejection or waiver is in the best interest of the County. The County reserves the right to reject the

Bid of a Bidder who has previously failed to perform properly or complete on time contracts of a similar nature, or a Bid from a Bidder whom investigation shows is not in a position to perform the contract.

- 1.8 Confidentiality of Documents:** Upon receipt of a proposal by the County the proposal shall become the property of the County without compensation to the Vendor, for disposition or usage by the County at its discretion. Respondent names who submit proposals on this RFQ and total prices will be read aloud publicly, but the details and particulars of the proposal documents will remain confidential until final award of the contract / purchase order.
- 1.9 Bidder:** Whenever the term "Bidder" is used it shall encompass the "person," "business," "contractor," "supplier," "vendor," or other party submitting a bid or proposal to Effingham County in such capacity before a contract has been entered into between such party and the County.
- Contract:** Whenever the term "Contract" is used it shall encompass "purchase order" and "agreement"
- 1.10 Responsible / Responsive Bidder:** Responsible Bidder means a person or entity that has the capability in all respects to perform fully and reliably the contract requirements. Responsive Bidder means a person or entity that has submitted a bid or proposal that conforms in all material respects to the requirements set forth in the request for quote.
- 1.11 Compliance with Laws:** The Bidder and/or contractor shall obtain and maintain all licenses, permits, liability insurance, workman's compensation insurance and comply with any and all other standards or regulations required by Federal, State or County statute, ordinances and rules during the performance of any contract between the contractor and the County. Any such requirement specifically set forth in any contract document between the contractor and the County shall be supplementary to this section and not in substitution thereof.
- 1.12 Governing Law:** Any contract and/or agreement and any addendums to it that result from this RFQ shall be governed by the laws of Georgia, with venue in Effingham County.
- 1.13 Contractor:** Contractor or subcontractor means any person or business having a contract with Effingham County. The Contractor/Vendor of construction, supplies, goods, material, equipment or services certifies that they will follow equal employment opportunity practices in connection with the awarded contract as more fully specified in the contract documents.
- 1.14 County:** Whenever the term "County" or "Owner" is used it is to refer to the Effingham County Board of Commissioners.
- 1.15 Debarred Firms and Pending Litigation:** Any potential bidder/firm listed on the Federal or State of Georgia Parties Listing (barred from doing business) **will not** be considered for contract award. Proposers **shall disclose** any record of pending criminal violations (Indictment) and/or convictions, pending lawsuits, etc., and any actions that may be a conflict of interest occurring within the past five (5) years. Any bidder/firm previously defaulting or terminating a contract with the County will not be considered.

Bidder acknowledges that in performing contract work for the County, Bidder shall not utilize any firms that have been a party to any of the above actions. If Bidder has engaged any firm to work on this contract or project that is later debarred, Bidder shall sever its relationship with the firm with respect to County contract.

** All Bidders are to read and complete the Bidder's certification regarding debarment, suspension, ineligibility, and voluntary exclusion enclosed as Attachment C to be returned with

response. Failure to do so may result in your solicitation response being rejected as non-responsive.

- 1.16 Protection of Resident Workers:** Effingham County Board of Commissioners actively supports the Immigration and Nationality Act (INA) which includes provisions addressing employment eligibility, employment verification, and nondiscrimination. Under the INA, employers may hire only persons who may legally work in the United States (i.e., citizens and nationals of the U.S.) and aliens authorized to work in the U.S. The employer must verify the identity and employment eligibility of anyone to be hired, which includes completing the Employment Eligibility Verification Form (I-9). The Contractor shall establish appropriate procedures and controls so no services or products under the Contract Documents will be performed or manufactured by any worker who is not legally eligible to perform such services or employment.
- 1.17 Immigration:** On 1 July 2009, the Georgia Security and Immigration Compliance Act (SB 529, Section 2) became effective. All employers, contractors and subcontractors entering into a contract or performing work must sign an affidavit that he/she has used the E-Verify System. E-Verify is a no-cost federal employment verification system to insure employment eligibility. Affidavits are enclosed in this solicitation. You may download M-274 Handbook for Employers at <http://www.dol.state.ga.us/spotlight/employment/rules>. You may go to <http://www.uscis.gov> to find the E-Verify information.

**** All Bidders are to read and complete the E-Verify affidavit enclosed as Attachment E to be returned with response. Failure to do so may result in your solicitation response being rejected as non-responsive**

- 1.18 Non-Collusion Affidavit:** All Vendors must complete the non-collusion affidavit enclosed as Attachment D per OCGA 36-91-21 (e).
- 1.19 Statement of Disclosure:** All Vendors must provide a statement of disclosure which will allow the County to evaluate possible conflicts of interest.

Interests of Public Officials.

The vendor warrants for itself and any subcontractor that no elected or appointed official or employee of Effingham County, Georgia, has any interest in their bid or the proceeds of any contract/agreement which may result thereof. In the event that an elected or appointed official or employee acquires any interest in any contract/agreement which may result from this bid, or the proceeds thereof, the vendor agrees to disclose such interest to the BOARD immediately by written notice. For breach or violation of this clause, the BOARD may annul any contract/agreement resulting from this bid without liability, terminate any contract/agreement resulting from this bid for default, or take other remedial measures. “Interest” as used herein means direct or indirect pecuniary or material benefit accruing to a county commissioner, official or employee as a result of a matter which is or which is expected to become the subject of an official action by or with the county, except for such actions which, by their terms and by the substance of their provisions, confer the opportunity and right to realize the accrual of similar benefits to all other persons and/or property similarly situated. The term “interest” shall not include any remote interest. For purposes of this bid, a county commissioner, official or employee shall be deemed to have an interest in the affairs of: (1) his or her family; (2) any business entity in which the county commissioner, official or employee is a member, officer, director, employee, or prospective employee; and (3) any business entity as to which the stock, legal ownership, or beneficial ownership of a county commissioner, official or employee is in excess of five percent of the total stock or total legal and beneficial ownership, or which is controlled or owned directly or indirectly by the county commissioner, official or employee. *Remote interest* as used herein means the interest of (1) a volunteer director, officer, or employee of a nonprofit corporation; (2) a holder of less than 5 percent of the legal or beneficial ownership of the total shares of a business;

(3) any person in a representative capacity, such as a receiver, trustee, or administrator. *Family* as used herein means the spouse, parents, children, and siblings, related by blood, marriage, or adoption, of a county official or employee.

1.20 Term of the Contract: One time lump sum.

1.21 Insurance Provisions: The selected Bidder shall be required to procure and maintain for the duration of the contract insurance against claims for injuries to persons or damages to property which may arise from or in connection with the performance of the work hereunder by the Vendor, his agents, representatives, employees or subcontractors. The cost of such insurance shall be included in the Vendor's fee proposal. **Contract work will not proceed unless Effingham County has in their possession, a current Certificate of Insurance. Effingham County invokes the defense of sovereign immunity. The County is not to be included as an additional insured on insurance contracts.**

General Information that shall appear on a Certificate of Insurance:

- A. Name of Producer (contractor's insurance Broker/Agent).
- B. Companies affording coverage (there may be several).
- C. Name and address of the Insured (this should be the Company or Parent of the firm Effingham County is contracting with).
- D. A Summary of all current insurance for the insured (includes effective dates of coverage).
- E. A brief description of the operations to be performed, the specific job to be performed, or contract number.
- F. Certificate Holder (**This is to always include Effingham County**).

Limits of Insurance:

Effective coverage shall have the following limits:

- A. **Commercial General Liability:** Provides protection against bodily injury and property damage claims arising from operations of a contractor or tenant. Minimum limits: \$300,000 bodily injury and property damage per occurrence and annual aggregate.
- B. **Worker's Compensation and Employer's Liability:** Provides statutory protection against bodily injury, sickness or disease sustained by employees of the contractor while performing within the scope of duties. Minimum limits: \$500,000 for each accident, disease policy limit, and disease each employee and Statutory Worker's Compensation limit.
- C. **Business Automobile Liability:** Coverage insures against liability claims arising out of the contractor's use of automobiles. Minimum limit: \$300,000 combined single limit per accident for bodily injury, property damage, and should be written on an "Any Auto" basis.

Special Requirements:

- A. **Claims-Made Coverage:** The limits of liability shall remain the same as the occurrence basis, however, the Retroactive date shall be prior to or coincident with the date of any contract, and the Certificate of Insurance shall state the retroactive date and the coverage is claims-made.
- B. **Extended Reporting Periods:** The contractor shall provide the County with a notice of the election to initiate any Supplemental Extended Reporting Period and the reason(s) for invoking this option.
- C. **Reporting Provisions:** Any failure to comply with reporting provisions of the policies shall not affect coverage provided in relation to this invitation.
- D. **Cancellation/Non-Renewal Notification:** Each insurance policy supplied in response to this invitation shall be endorsed to state that it shall not be suspended, voided, or canceled, except after thirty (30) days prior to written notice by certified mail, return receipt, has been given to the County.

- E. **Proof of Insurance:** Effingham County shall be furnished with certificates of insurance and original endorsements affecting coverage required by this invitation. The certificates and endorsements are to be signed by a person authorized by the insurer to bind coverage on its behalf. All certificates of insurance are to be submitted prior to, and approved by, the County before services are rendered. The Vendor must ensure Certificates of Insurance are updated for the entire term of the Contract.
- F. **Insurer Acceptability:** Insurance is to be placed with an insurer having an A.M. Best's rating of A and a five (5) year average financial rating of not less than V. If an insurer does not qualify for averaging on a five year basis, the current total Best's rating will be used to evaluate insurer acceptability.
- G. **Lapse in Coverage:** A lapse in coverage shall constitute grounds for contract termination by Effingham County Board of Commissioners.
- H. **Deductible and Self-Insured Retention:** Any deductibles or self-insured retention must be declared to, and approved by, the County. At the option of the County, either: the insurer shall reduce or eliminate such deductibles or self-insured retention as related to the County, its officials, officers, employees, and volunteers; or the Vendor shall procure a bond guaranteeing payment of related suits, losses, claims and related investigation, claim administration and defense expenses

1.22 Additional Coverage for Engineering, Architectural and Surveying Services: Professional Liability: Insure errors or omission on behalf of architects, engineers, attorneys, medical professionals, and consultants. Minimum Limits: \$1,000,000 per claim/occurrence. Coverage Requirement: If "claims made," retroactive date must precede or coincide with the contract effective date or the date of the Notice to Proceed. The professional must state if "tail" coverage has been purchased and the duration of the coverage.

1.24 Indemnification: The CONTRACTOR agrees to protect, defend, indemnify, and hold harmless Effingham County, Georgia, its commissioners, officers, agents, and employees from and against any and all liability, damages, claims, suits, liens, and judgments, of whatever nature, including claims for contribution and/or indemnification, for injuries to or death of any person or persons, or damage to the property or other rights of any person or persons caused by the CONTRACTOR or its subcontractors. The CONTRACTOR'S obligation to protect, defend, indemnify, and hold harmless, as set forth herein above shall include, but not be limited to, any matter arising out of any actual or alleged infringement of any patent, trademark, copyright, or service mark, or any actual or alleged unfair competition, disparagement of product or service, or other business tort of any type whatsoever, or any actual or alleged violation of trade regulations. CONTRACTOR further agrees to investigate, handle, respond to, provide defense for, and to protect, defend, indemnify, and hold harmless Effingham County, Georgia, at his sole expense, and agrees to bear all other costs and expenses related thereto, even if such claims, suits, etc., are groundless, false, or fraudulent, including any and all claims or liability for compensation under the Worker's Compensation Act arising out of injuries sustained by any employee of the CONTRACTOR or his subcontractors or anyone directly or indirectly employed by any of them. The CONTRACTOR'S obligation to indemnify Effingham County under this Section shall not be limited in any way by the agreed-upon contract price, or to the scope and amount of coverage provided by any insurance maintained by the CONTRACTOR.

1.25 Payments: Payment of invoices will be made within the time frame specified in the contract resulting from this RFQ.

Final payment for any work contracted as a result of this RFQ shall be made within the time frame specified in the contract resulting from this RFQ.

Notwithstanding any other payment provisions of a contract resulting from this RFQ, failure of the Contractor to submit required reports when due or failure to perform or deliver required work, supplies, or services, may result in the withholding of full payment under a contract resulting from this RFQ

unless such failure arises out of causes beyond the control, and without the fault or negligence of the Contractor. The County will immediately notify the Contractor of its intention to withhold payment of any invoice or voucher submitted for work performed under a contract resulting from this RFQ.

INTENTIONALLY LEFT BLANK

**ATTACHMENT A
DRUG FREE WORKPLACE CERTIFICATION**

The undersigned certifies that the provisions of Code Sections 50-24-1 through 50-24-6 of the Official Code to Georgia Annotated, related to the Drug Free Workplace have been complied with.

1. A drug-free workplace will be provided for the employees during the performance of the contract;
and;

2. Each Subcontractor under the direction of the contractor shall secure the following written certification:

_____ (Contractor) certifies to Effingham County that a drug-free workplace will be provided for the employees during the performance of this contract known as **RFQ No. 19-25-003 – One (1) New Wheeled Excavator** pursuant to paragraph (7) of subsection (B) of Code Section 50-24-3. Also, the undersigned further certifies that he/she will not engage in the unlawful manufacture, sale, distribution, dispensation, possession, or use of a controlled substance or marijuana during the performance of the contract.

CONTRACTOR

DATE

SUBSCRIBED AND SWORN BEFORE ME ON THIS THE

____ DAY OF _____, 20____

Notary Public

My Commission Expires: _____, 20____

**ATTACHMENT B
PROMISE OF NON-DISCRIMINATION STATEMENT**

Know all men by these presence, that I (We), _____,
Name

_____, _____
Title Company

(herein after "Company"), in consideration of the privilege to Bid/Propose on the following Effingham County Procurement titled **RFQ No. 19-25-003 – One (1) New Wheeled Excavator** hereby consent, covenant, and agree as follows:

- A. No person shall be excluded from participation in, denied the benefit of, or otherwise discriminated against on the basis of race, color, national origin or gender in connection with the Proposal submitted to Effingham County or the performance of the contract resulting there from.
- B. That it is and shall be the policy of this Company to provide equal opportunity to all business persons seeking to contract with or otherwise interested in the Company, including those companies owned and controlled by racial minorities and women.
- C. That the promises of non-discrimination as made and set forth herein shall be continuing throughout the duration of this contract with Effingham County.
- D. That the promises of non-discrimination as made and set forth herein shall be and are hereby deemed to be made part of and incorporated by reference in the contract which this Company may be awarded.
- E. That the failure of this Company to satisfactorily discharge any of the promises of non-discrimination as made and set forth above may constitute a material breach of contract entitling the County to declare the contract in default and to exercise appropriate remedies including but not limited to termination of the contract.

SIGNATURE

DATE:

SUBSCRIBED AND SWORN BEFORE ME ON THIS THE

____ DAY OF _____, 20____

Notary Public

My Commission Expires: _____, 20____

ATTACHMENT C
DISCLOSURE OF RESPONSIBILITY STATEMENT (page 1)

Failure to complete and return this information will result in your bid/offer/proposal being disqualified from further competition as non-responsive.

1. List any convictions of any person, subsidiary, or affiliate of the company, arising out of obtaining, or attempting to obtain a public or private contract or subcontract, or in the performance of such contract or subcontract.
2. List any indictments or convictions of any person, subsidiary, or affiliate of this company for offenses such as embezzlement, theft, fraudulent schemes, etc. or any other offenses indicating a lack of business integrity or business honesty which affects the responsibility of the contractor.
3. List any convictions or civil judgments under states or federal antitrust statutes.
4. List any violations of contract provisions such as knowingly failing (without good cause) failing to perform, or unsatisfactory performance, in accordance with the specifications of a contract.
5. List any prior suspensions or debarments by any governmental agency.
6. List any contracts not completed on time.
7. List any penalties imposed for time delays and/or quality of materials and workmanship.
8. List any documented violations of federal or any state labor laws, regulations, or standards, and any occupational safety and health rules.
9. List any potential conflicts of interest your firm may have in performing the requested services.
10. List any potential conflicts of interest that any members of your firm may have in performing the requested services.

NOTE: The penalty for making false statements in offers is prescribed in 18 U.S.C. 1001

DISCLOSURE OF RESPONSIBILITY STATEMENT (page 2)

I hereby certify that I am the _____ and duly authorized

representative of _____ (Contractor) whose address is

and I certify that I have read and understand the attached instructions and that to the best of my knowledge and belief the firm and its representatives:

(a) Are not presently debarred, suspended, proposed for debarment, declared ineligible, or voluntarily excluded from covered transactions by the Georgia Department of Transportation, any Federal Department or Agency, Board of Education or local municipality.

(b) I acknowledge that this certification is provided pursuant to Executive Order 12549 and 49 CFR Part 29 and that this firm agrees to abide by the rules and conditions set forth therein for any misrepresentation that would render this certification erroneous, including termination of this Agreement and other remedies available to the Georgia Department of Transportation, Federal Government, Board of Education or local municipality.

(c) I further acknowledge that this firm will include this clause without modification in all lower tier transactions, solicitations, proposals, contracts and subcontracts. Where the Bidder or any lower tier participant is unable to certify to this statement, that participant shall attach an explanation to this document.

I, _____, as _____
Name of individual Title & Authority

of _____, declare under oath that the above statements,
Company Name

including any supplemental responses attached hereto, are true.

Signature

State of: _____

County of : _____

DISCLOSURE OF RESPONSIBILITY STATEMENT (page 3)

SUBSCRIBED AND SWORN BEFORE ME ON THIS THE

_____ DAY OF _____, 20____

by _____ representing him/herself to be

_____ of the company named.

Notary Public

My Commission Expires: _____, 20____

INTENTIONALLY LEFT BLANK

**ATTACHMENT D
NON-COLLUSIVE AFFIDAVIT OF SUBCONTRACTOR**

I, _____ certify that pursuant to Effingham County Board of Commissioner’s policies, this bid or proposal is made without prior understanding, agreement or connection with any corporation, firm or person submitting a bid or proposal for the same work, labor or service to be done or the supplies, materials or equipment to be furnished and is in all respects fair and without collusion or fraud of any type. I understand collusive bidding is a violation of State and Federal law and can result in fines, prison sentences and civil damages awards. I agree to abide by all conditions of this bid or proposal and certify that I am authorized by my employer to sign this statement on their behalf.

Affiant further states that pursuant to O.C.G.A. Section 36-91-21 (d) and (e),

Contractor

has not, by itself or with any others, directly or indirectly, prevented or attempted to prevent competition in such bidding or proposals by any means whatsoever. Affiant further states that (s)he has not prevented or endeavored to prevent anyone from making a bid or offer on this project by any means whatsoever, nor has Affiant caused or induced another to withdraw a bid or offer for the work and/or to submit an invalid and or incorrect bid or offer for the work.

Affiant further states that the said offer of _____ is a bona fide offer, and that no one has contacted any supplier and attempted to get such person or company to furnish the materials to the bidder only, or if furnished to other bidders, to do so at a higher prices.

Company’s Name

President / Vice President / Principal / Owner

Sworn to and subscribed before me this _____ day of _____, 201 _____

Secretary / Assistant Secretary

Affix corporate seal here, if a corporation

SUBSCRIBED AND SWORN BEFORE ME ON THIS THE

____ day of _____ 20____

Notary Public

My Commission Expires _____, 20____

NOTE: If the contractor is a partnership, all of the partners and officers, agents, or other persons who may have represented or acted on behalf of the partnership in bidding for or procuring this contract shall also make this oath. If the subcontractor is a corporation, all of the officers, agents, or other persons who may have represented or acted on behalf of the corporation in bidding for or procuring this contract shall also make this oath.

**ATTACHMENT E
CONTRACTOR AFFIDAVIT AND AGREEMENT**

By executing this affidavit, the undersigned Contactor verifies its compliance with O.C.G.A. § 13-10-91, stating affirmatively that the individual, firm, or corporation that is contracting with Effingham County has registered with and is participating in a federal work authorization program* [any of the electronic verification of work authorization programs operated by the United States Department of Homeland Security or any equivalent federal work authorization program operated by the United States Department of Homeland Security to verify information of newly hired employees, pursuant to the Immigration Reform and Control Act of 1986 (IRCA), P.L. 99-603], in accordance with the applicability provisions and deadlines established in O.C.G.A. § 13-10-91, and shall agree to use this program for any newly hired employees throughout the duration of the contract.

The undersigned further agrees that, should it employ or contract with any subcontractor(s) in connection with the physical performance of services pursuant to this contract with Effingham County, contractor will secure from such subcontractor similar verification of compliance with O.C.G.A. § 13-10-91 on the subcontractor Affidavit provided in Rule 300-10-01-.08 or a substantially similar form. The contractor further agrees to provide notice to the County of the identity of each subcontractor hired under the contract within five (5) business days of entering into a contract for hire. Such notice shall include a copy of the Subcontractor Affidavit for each subsequent subcontractor attesting to the subcontractor's name, address, user identification number, and date of authorization to use the federal work authorization program. Contractor further agrees to maintain records of such compliance and provide a copy of each such verification to the Effingham County within five (5) days of the time the subcontractor(s) is retained to perform such service.

EEV / Basic Pilot Program* User Identification Number

Date of E-Verify Authorization

Legal Name of Company

Legal Address of Company

BY: Authorized Officer or Agent of Contractor (Signature)

Date

Title & Printed Name of Authorized Officer or Agent of Contractor

SUBSCRIBED AND SWORN BEFORE ME ON THIS THE

____ DAY OF _____ 20 ____

Notary Public

My Commission Expires: _____, 20 ____

* As of the effective date of O.C.G.A. § 13-10-91, the applicable federal work authorization program is the "EEV/ Basic Pilot Program" operated by the U.S. Citizenship and Immigration Services Bureau of the U.S. Department of Homeland Security, in conjunction with the Social Security Administration (SSA).

If contractor has no employees and has no intent to hire employees, instead of this affidavit, contractor must provide their driver's license

**ATTACHMENT F
SUBCONTRACTOR AFFIDAVIT (E-VERIFY)**

By executing this affidavit, the undersigned subcontractor verifies its compliance with O.C.G.A. § 13-10-91, stating affirmatively that the individual, firm or corporation that is engaged in the physical performance of services under a contract with (name of contractor) on behalf of Effingham County has registered with and is participating in a federal work authorization program* [any of the electronic verification of work authorization programs operated by the United States Department of Homeland Security or any equivalent federal work authorization program operated by the United States Department of Homeland Security to verify information of newly hired employees, pursuant to the Immigration Reform and Control Act of 1986 (IRCA), P.L. 99-603], in accordance with the applicability provisions and deadlines established in O.C.G.A. § 13-10-91 and will agree to use this program for any newly hired employees throughout the duration of the contract. The subcontractor further agrees to provide a copy of the executed Subcontractor Affidavit to the Contractor in order to be provided to the County within five (5) days entering into the contract for hire.

EEV / Basic Pilot Program* User Identification Number

Date of E-Verify Authorization

Legal Name of Company

Legal Address of Company

BY: Authorized Officer or Agent of Subcontractor (Signature)

Date

Title & Printed Name of Authorized Officer or Agent of Subcontractor

SUBSCRIBED AND SWORN BEFORE ME ON THIS THE

____ DAY OF _____ 20 ____

Notary Public

My Commission Expires: _____, 20 ____

* As of the effective date of O.C.G.A. 13-10-91, the applicable federal work authorization program is the "EEV/ Basic Pilot Program" operated by the U. S. Citizenship and Immigration Services Bureau of the U.S. Department of Homeland Security, in conjunction with the Social Security Administration (SSA).

If subcontractor has no employees and has no intent to hire employees, instead of this affidavit, subcontractor must provide their driver's license

(IF NO SUBCONTRACTORS WILL BE USED PLEASE MARK "N/A" BEFORE RETURNING)

ACORDTM CERTIFICATE OF LIABILITY INSURANCE		DATE (MM/DD/YYYY)
PRODUCER	THIS CERTIFICATE IS ISSUED AS A MATTER OF INFORMATION ONLY AND CONFERS NO RIGHTS UPON THE CERTIFICATE HOLDER. THIS CERTIFICATE DOES NOT AMEND, EXTEND OR ALTER THE COVERAGE AFFORDED BY THE POLICIES BELOW.	
INSURED	INSURERS AFFORDING COVERAGE	NAIC #
	INSURER A:	
	INSURER B:	
	INSURER C:	
	INSURER D:	
	INSURER E:	

COVERAGES
 THE POLICIES OF INSURANCE LISTED BELOW HAVE BEEN ISSUED TO THE INSURED NAMED ABOVE FOR THE POLICY PERIOD INDICATED. NOTWITHSTANDING ANY REQUIREMENT, TERM OR CONDITION OF ANY CONTRACT OR OTHER DOCUMENT WITH RESPECT TO WHICH THIS CERTIFICATE MAY BE ISSUED OR MAY PERTAIN, THE INSURANCE AFFORDED BY THE POLICIES DESCRIBED HEREIN IS SUBJECT TO ALL THE TERMS, EXCLUSIONS AND CONDITIONS OF SUCH POLICIES. AGGREGATE LIMITS SHOWN MAY HAVE BEEN REDUCED BY PAID CLAIMS.

INSR ADD'L LTR	INSRD	TYPE OF INSURANCE	POLICY NUMBER	POLICY EFFECTIVE DATE (MM/DD/YY)	POLICY EXPIRATION DATE (MM/DD/YY)	LIMITS
		GENERAL LIABILITY <input type="checkbox"/> COMMERCIAL GENERAL LIABILITY <input type="checkbox"/> CLAIMS MADE <input type="checkbox"/> OCCUR GEN'L AGGREGATE LIMIT APPLIES PER: <input type="checkbox"/> POLICY <input type="checkbox"/> PRO-JECT <input type="checkbox"/> LOC				EACH OCCURRENCE \$ DAMAGE TO RENTED PREMISES (Ea occurrence) \$ MED EXP (Any one person) \$ PERSONAL & ADV INJURY \$ GENERAL AGGREGATE \$ PRODUCTS - COMP/OP AGG \$
		AUTOMOBILE LIABILITY <input type="checkbox"/> ANY AUTO <input type="checkbox"/> ALL OWNED AUTOS <input type="checkbox"/> SCHEDULED AUTOS <input type="checkbox"/> HIRED AUTOS <input type="checkbox"/> NON-OWNED AUTOS				COMBINED SINGLE LIMIT (Ea accident) \$ BODILY INJURY (Per person) \$ BODILY INJURY (Per accident) \$ PROPERTY DAMAGE (Per accident) \$
		GARAGE LIABILITY <input type="checkbox"/> ANY AUTO				AUTO ONLY - EA ACCIDENT \$ OTHER THAN EA ACC \$ AUTO ONLY: AGG \$
		EXCESS/UMBRELLA LIABILITY <input type="checkbox"/> OCCUR <input type="checkbox"/> CLAIMS MADE DEDUCTIBLE \$ RETENTION \$				EACH OCCURRENCE \$ AGGREGATE \$ \$ \$ \$
		WORKERS COMPENSATION AND EMPLOYERS' LIABILITY ANY PROPRIETOR/PARTNER/EXECUTIVE OFFICER/MEMBER EXCLUDED? If yes, describe under SPECIAL PROVISIONS below OTHER				WC STATU-TORY LIMITS \$ OTH-ER \$ E.L. EACH ACCIDENT \$ E.L. DISEASE - EA EMPLOYEE \$ DISEASE - POLICY LIMIT \$

DESCRIPTION OF OPERATIONS / LOCATIONS / VEHICLES / EXCLUSIONS ADDED BY ENDORSEMENT / SPECIAL PROVISIONS

CERTIFICATE HOLDER	CANCELLATION
	SHOULD ANY OF THE ABOVE DESCRIBED POLICIES BE CANCELLED BEFORE THE EXPIRATION DATE THEREOF, THE ISSUING INSURER WILL ENDEAVOR TO MAIL _____ DAYS WRITTEN NOTICE TO THE CERTIFICATE HOLDER NAMED TO THE LEFT, BUT FAILURE TO DO SO SHALL IMPOSE NO OBLIGATION OR LIABILITY OF ANY KIND UPON THE INSURER, ITS AGENTS OR REPRESENTATIVES. AUTHORIZED REPRESENTATIVE

IMPORTANT

If the certificate holder is an ADDITIONAL INSURED, the policy(ies) must be endorsed. A statement on this certificate does not confer rights to the certificate holder in lieu of such endorsement(s).

If SUBROGATION IS WAIVED, subject to the terms and conditions of the policy, certain policies may require an endorsement. A statement on this certificate does not confer rights to the certificate holder in lieu of such endorsement(s).

DISCLAIMER

The Certificate of Insurance on the reverse side of this form does not constitute a contract between the issuing insurer(s), authorized representative or producer, and the certificate holder, nor does it affirmatively or negatively amend, extend or alter the coverage afforded by the policies listed thereon.

ATTACHMENT G
NO-BID STATEMENT

In an effort to make the procurement of construction, goods and services for Effingham County as competitive as possible, we are soliciting information from contractors and or vendors who cannot Bid. Your “responsiveness” and “constructive” comments will be appreciated. Completion of this form will assist us in evaluating factors which relate to the competitiveness of our Bids. Please check any of the boxes below which may apply.

- Specifications - Restrictive, too “tight”, unclear, specialty item, geared toward one (1) brand or manufacturer only. (Explain below)
- Manufacturing - Unique item, production time for model or item has expired, etc.
- Bid Time - Insufficient time to properly respond to Bid or proposal.
- Delivery Time - Specified delivery time cannot be met.
- Payment - Delay in payment terms. Please be specific.
- Bonding - We are unable to meet bonding requirements.
- Insurance - We are unable to meet insurance requirements.
- Removal - From Bidders list for this particular commodity or service.
- Keep - Our Company on your Bidders list for future reference.
- Project is - Too Large _____ Too Small __ Site Location Too Distant .
- Miscellaneous - Do not wish to Bid, do not handle this type of item (s), unable to compete, contract clause (s) not acceptable, etc. Please be specific.

CONSTRUCTION PROJECTS: Please provide reason for obtaining a Bid package. Check one below.

- Interest in this project as a: Prime Contractor _____ ,
- Sub-Contractor _____ . Supplier _____ .

RFQ No. 19-25-005 – One (1) New Wheeled Excavator

Signature: _____ Telephone Number: _____

Firm Name: _____

G-SERIES
**190G W WHEELED
EXCAVATOR**



JOHN DEERE



**WHEELED
WARRIOR**



190G W SPECIFICATIONS

Engine		190G W	
Manufacturer and Model	Isuzu 4HK1XASA13A		
Non-Road Emission Standard	EPA Final Tier 4/EU Stage IV		
Net Peak Power (ISO 9249)	129 kW (173 hp) at 1,800 rpm		
Cylinders	4		
Displacement	5.2 L (317 cu. in.)		
Off-Level Capacity	70% (35 deg.)		
Aspiration	Turbocharged, air-to-air charge-air cooler		
Cooling			
Cool-on-demand hydraulic-driven, suction-type fan with remote-mounted drive and enclosed fan guard; side-by-side-by-side radiator, oil cooler, and intercooler with dust net			
Powertrain			
2-speed propel with creeper mode and automatic shift			
Maximum Travel Speed			
Creep	2.6 km/h (1.6 mph)		
Low	8.6 km/h (5.3 mph)		
High	35.0 km/h (21.7 mph)		
Drawbar Pull	9534 kg (21,020 lb.)		
Brakes	Maintenance-free wet-disc brakes on front and rear axles; fully hydraulic service brakes		
Tires	Standard size, dual-traction-type 10.00-20 16PR tires		
Front Axle	All-wheel drive; can be locked hydraulically in any position		
Hydraulics			
Main Pumps	2 variable-displacement axial-piston pumps		
Maximum Rated Flow x 2	236 L/min. (62 gpm)		
Pilot Pump	1 gear		
Maximum Rated Flow	30 L/m (8 gpm)		
Pressure Setting	4700 kPa (682 psi)		
System Operating Pressure			
Implement Circuits	34 300 kPa (4,975 psi)		
Travel Circuits	34 800 kPa (5,047 psi)		
Swing Circuits	33 400 kPa (4,844 psi)		
Power Boost	36 300 kPa (5,265 psi)		
Controls	Pilot levers, short stroke, low-effort hydraulic pilot controls with shutoff lever		
Cylinders			
	<i>Bore</i>	<i>Rod Diameter</i>	<i>Stroke</i>
Monoblock Boom (2)	120 mm (4.7 in.)	85 mm (3.3 in.)	1050 mm (41.3 in.)
2-Piece Boom (2)	120 mm (4.7 in.)	85 mm (3.3 in.)	980 mm (38.6 in.)
Positioning, 2-Piece Boom (2)	170 mm (6.7 in.)	105 mm (4.1 in.)	670 mm (26.4 in.)
Arm (1)	125 mm (4.9 in.)	90 mm (3.5 in.)	1371 mm (54.0 in.)
Bucket (1)	105 mm (4.1 in.)	75 mm (3.0 in.)	1060 mm (41.7 in.)

190G W SPECIFICATIONS



Electrical		190G W	
Number of Batteries (12 volt)	2		
Battery Capacity	925 CCA		
Alternator Rating	50 amp		
Worklights	1 on boom left, 2 on top of cab front, and 1 on top of cab rear		
Driving Lights	Headlights (2), turn signals and hazard lights, LED brake lights, and side marker lights		
Swing Mechanism			
Swing Speed	11.5 rpm		
Swing Torque	53 000 Nm (39,090 lb.-ft.)		
Serviceability			
Refill Capacities			
Fuel Tank	290 L (76.6 gal.)		
Coolant System	28 L (7.4 gal.)		
Engine Oil with Filter	23 L (6.1 gal.)		
Swing Gearbox	6.2 L (1.6 gal.)		
Front and Rear Hub Reduction (each)	2.5 L (0.7 gal.)		
Hydraulic System	180 L (47.6 gal.)		
Hydraulic Tank	100 L (26.4 gal.)		
Transmission	2.5 L (2.6 qt.)		
Axle			
Front	9.5 L (2.5 gal.)		
Rear	14 L (3.7 gal.)		
Diesel Exhaust Fluid (DEF) Tank	26 L (6.9 gal.)		
Operating Weights			
With 1.38-m ³ (1.81 cu. yd.), 1219-mm (48 in.), 735-kg (1,621 lb.) bucket; 2.71-m (8 ft. 11 in.) arm; 3700-kg (8,157 lb.) counterweight; 2550-mm (8 ft. 4 in.)-wide wheelbase; full fuel tank; and 75-kg (165 lb.) operator			
	<i>Monoblock Boom</i>	<i>2-Piece Boom</i>	
Front Blade and Rear Outrigger	19 700 kg (43,431 lb.)	20 200 kg (44,533 lb.)	
Front and Rear Outriggers	20 000 kg (44,530 lb.)	20 500 kg (45,300 lb.)	
Component Weights			
Undercarriage, Base			
Front Blade and Rear Outrigger	2257 kg (4,976 lb.)	2257 kg (4,976 lb.)	
Front and Rear Outriggers	2601 kg (5,734 lb.)	2601 kg (5,734 lb.)	
Arm with Bucket Cylinder and Linkage			
2.71-m (8 ft. 11 in.) Arm without Cylinder	570 kg (1,257 lb.)	570 kg (1,257 lb.)	
Without Cylinder	1262 kg (2,782 lb.)	1580 kg (3,483 lb.)	
Cylinder(s), Total Weight			
Boom Lift (2)	155 kg (342 lb.)	155 kg (342 lb.)	
Positioning (1)	309 kg (681 lb.)	309 kg (681 lb.)	
Arm (1)	212 kg (467 lb.)	212 kg (467 lb.)	
Bucket (1)	127 kg (280 lb.)	127 kg (280 lb.)	

190G W

Operating Dimensions	190G W	
With 2.71-m (8 ft. 11 in.) Arm	<i>Monoblock Boom</i>	<i>2-Piece Boom</i>
Arm Digging Force		
ISO	95 kN (21,360 lb.)	95 kN (21,360 lb.)
SAE	91 kN (20,460 lb.)	91 kN (20,460 lb.)
Bucket Digging Force		
ISO	126 kN (28,330 lb.)	126 kN (28,330 lb.)
SAE	113 kN (25,400 lb.)	113 kN (25,400 lb.)
A Maximum Reach	9.58 m (31 ft. 5 in.)	9.48 m (31 ft. 1 in.)
A' Maximum Reach at Ground Level	9.40 m (30 ft. 10 in.)	9.31 m (30 ft. 7 in.)
B Maximum Digging Depth	5.83 m (19 ft. 2 in.)	5.93 m (19 ft. 5 in.)
B' Maximum Digging Depth at 2.44-m (8 ft.) Flat Bottom	5.64 m (18 ft. 6 in.)	5.83 m (19 ft. 2 in.)
C Maximum Cutting Height	9.25 m (30 ft. 4 in.)	9.85 m (32 ft. 4 in.)
D Maximum Dumping Height	6.45 m (21 ft. 2 in.)	6.95 m (22 ft. 10 in.)
E Minimum Swing Radius	3.48 m (11 ft. 5 in.)	3.00 m (9 ft. 10 in.)
F Maximum Vertical Wall	5.26 m (17 ft. 3 in.)	5.03 m (16 ft. 6 in.)

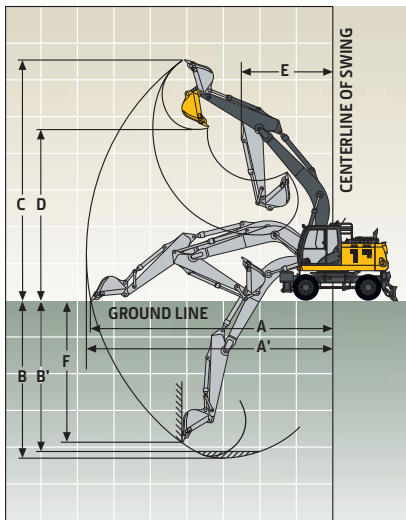

190G W EXCAVATOR WITH MONOBLOCK BOOM

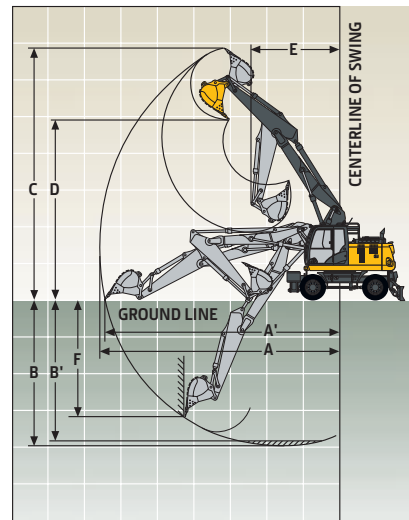

190G W EXCAVATOR WITH 2-PIECE BOOM

Machine Dimensions	190G W	
With 2.71-m (8 ft. 11 in.) Arm	<i>Monoblock Boom</i>	<i>2-Piece Boom</i>
A Overall Length		
Front Blade and Rear Outrigger	9.48 m (31 ft. 1 in.)	9.30 m (30 ft. 6 in.)
Front and Rear Outriggers	9.54 m (31 ft. 4 in.)	9.36 m (30 ft. 9 in.)
B Overall Height	3.12 m (10 ft. 3 in.)	3.21 m (10 ft. 6 in.)
C Rear-End Length/Swing Radius	2.32 m (7 ft. 7 in.)	2.32 m (7 ft. 7 in.)
D Engine Cover Height	2.59 m (8 ft. 6 in.)	2.59 m (8 ft. 6 in.)
E Counterweight Clearance	1.22 m (4 ft. 0 in.)	1.22 m (4 ft. 0 in.)
F Overall Width of Upperstructure	2.45 m (8 ft. 0 in.)	2.45 m (8 ft. 0 in.)
G Overall Height of Cab	3.22 m (10 ft. 7 in.)	3.22 m (10 ft. 7 in.)
H Overall Width of Tires	2.73 m (8 ft. 11 in.)	2.73 m (8 ft. 11 in.)
J Minimum Ground Clearance	0.35 m (14 in.)	0.35 m (14 in.)
K Wheelbase	2.65 m (8 ft. 8 in.)	2.65 m (8 ft. 8 in.)
L Swing Center to Rear Axle	1.15 m (3 ft. 9 in.)	1.15 m (3 ft. 9 in.)
M Front Overhang		
Front Blade and Rear Outrigger	1.36 m (4 ft. 6 in.)	1.36 m (4 ft. 6 in.)
Front and Rear Outriggers	1.38 m (4 ft. 6 in.)	1.38 m (4 ft. 6 in.)
N Rear Overhang	1.09 m (3 ft. 7 in.)	1.09 m (3 ft. 7 in.)
O Maximum Blader Lower	0.22 m (9 in.)	0.22 m (9 in.)
P Overall Height of Blade	0.59 m (23 in.)	0.59 m (23 in.)
Q Maximum Blade Raise	0.37 m (15 in.)	0.37 m (15 in.)
R Overall Width of Blade	2.73 m (8 ft. 11 in.)	2.73 m (8 ft. 11 in.)
S Overall Width, Outriggers Retracted	2.45 m (8 ft. 0 in.)	2.45 m (8 ft. 0 in.)
T Overall Width, Outriggers Extended	3.44 m (11 ft. 3 in.)	3.44 m (11 ft. 3 in.)
V Overall Height of Boom, Traveling	4.00 m (13 ft. 1 in.)	4.00 m (13 ft. 1 in.)
W Front Overhang, Traveling	3.33 m (10 ft. 11 in.)	3.33 m (10 ft. 11 in.)

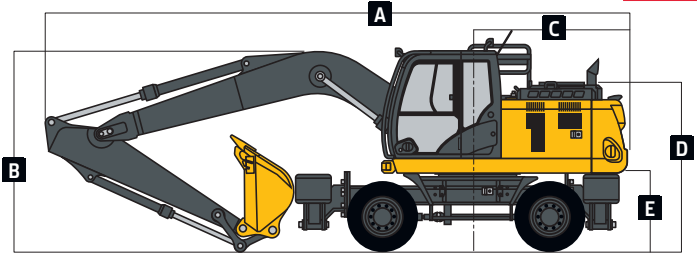
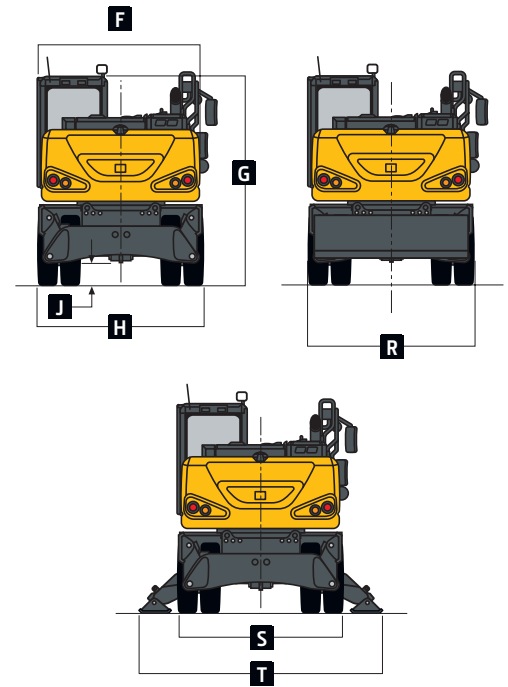

190G W EXCAVATOR WITH MONOBLOCK BOOM

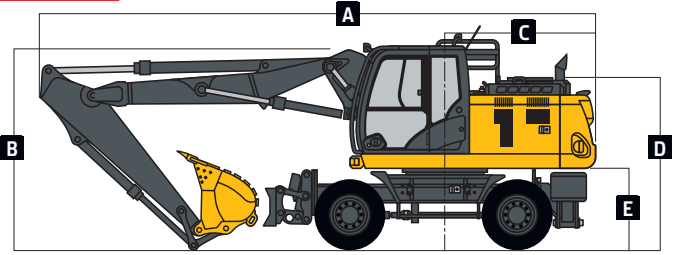

190G W EXCAVATOR WITH 2-PIECE BOOM

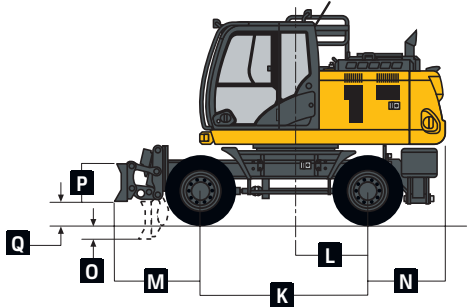

190G W EXCAVATOR WITH FRONT BLADE AND REAR OUTRIGGER

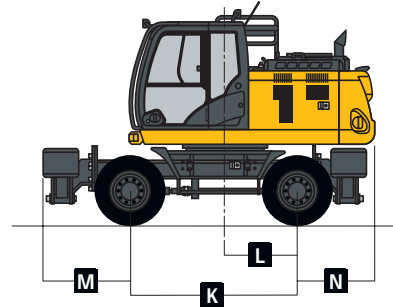

190G W EXCAVATOR WITH FRONT AND REAR OUTRIGGERS

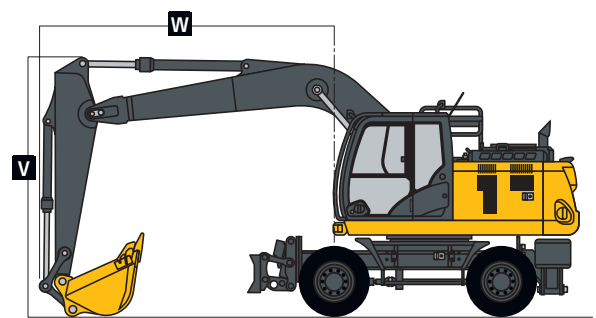

190G W EXCAVATOR WITH MONOBLOCK BOOM (TRAVELING)

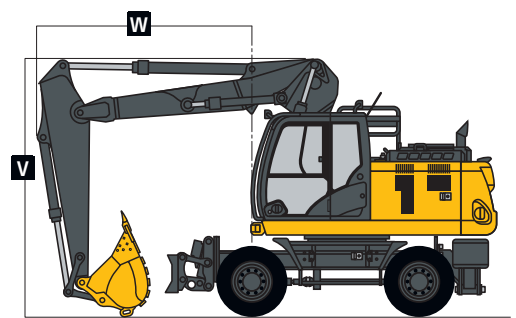

190G W EXCAVATOR WITH 2-PIECE BOOM (TRAVELING)

190G W

Lift Capacities 190G W

Boldface type indicates hydraulically limited capacities; lightface type indicates stability-limited capacities, in kg (lb.). Ratings at bucket lift hook; machine equipped with 600-kg (1,323 lb.) bucket, 2.71-m (8 ft. 11 in.) arm, wide tires, and standard counterweight; and situated on firm, level, uniform supporting surface, with power boost on. Figures do not exceed 87% of hydraulic capacity or 75% of weight needed to tip machine.

LOAD POINT HEIGHT	HORIZONTAL DISTANCE FROM CENTERLINE OF ROTATION									
	1.5 m (5 ft.)		3.0 m (10 ft.)		4.5 m (15 ft.)		6.0 m (20 ft.)		7.5 m (25 ft.)	
	Over Front	Over Side	Over Front	Over Side	Over Front	Over Side	Over Front	Over Side	Over Front	Over Side
<i>With monoblock boom; front blade and rear outriggers down</i>										
6.0 m (20 ft.)							4270	4270		
							(9,420)	(9,420)		
4.5 m (15 ft.)					6230	6230	5240	4620		
					(13,740)	(13,740)	(11,560)	(10,180)		
3.0 m (10 ft.)					7730	7120	5830	4420	4480	3020
					(17,040)	(15,690)	(12,850)	(9,750)	(9,870)	(6,650)
1.5 m (5 ft.)					8880	6670	6350	4220	5000	2930
					(19,570)	(14,700)	(14,010)	(9,300)	(11,030)	(6,450)
Ground Line		4090	4090	9130	6430	6540	4070	4940	2860	
		(9,010)	(9,010)	(20,130)	(14,170)	(14,420)	(8,980)	(10,900)	(6,300)	
-1.5 m (-5 ft.)		8190	8190	8500	6360	6170	4020			
		(18,050)	(18,050)	(18,740)	(14,030)	(13,600)	(8,860)			
-3.0 m (-10 ft.)		9380	9380	6980	6430	4900	4070			
		(20,680)	(20,680)	(15,380)	(14,180)	(10,810)	(8,970)			
<i>With monoblock boom; front outriggers and rear outriggers down</i>										
6.0 m (20 ft.)							4270	4270		
							(9,420)	(9,420)		
4.5 m (15 ft.)					6230	6230	5240	5240		
					(13,740)	(13,740)	(11,560)	(11,560)		
3.0 m (10 ft.)					7730	7730	5830	5160	4480	3530
					(17,040)	(17,040)	(12,850)	(11,370)	(9,870)	(7,780)
1.5 m (5 ft.)					8880	7910	6350	4950	5000	3440
					(19,570)	(17,440)	(14,010)	(10,910)	(11,030)	(7,580)
Ground Line		4090	4090	9130	7660	6540	4800	4940	3370	
		(9,010)	(9,010)	(20,130)	(16,880)	(14,420)	(10,580)	(10,900)	(7,420)	
-1.5 m (-5 ft.)		8190	8190	8500	7590	6170	4740			
		(18,050)	(18,050)	(18,740)	(16,730)	(13,600)	(10,450)			
-3.0 m (-10 ft.)		9380	9380	6980	6980	4900	4790			
		(20,680)	(20,680)	(15,380)	(15,380)	(10,810)	(10,570)			

Lift Capacities (continued)

190G W

Boldface type indicates hydraulically limited capacities; **lightface type** indicates stability-limited capacities, in kg (lb.). Ratings at bucket lift hook; machine equipped with 600-kg (1,323 lb.) bucket, 2.71-m (8 ft. 11 in.) arm, wide tires, and standard counterweight; and situated on firm, level, uniform supporting surface, with power boost on. Figures do not exceed 87% of hydraulic capacity or 75% of weight needed to tip machine.

HORIZONTAL DISTANCE FROM CENTERLINE OF ROTATION

LOAD POINT HEIGHT	1.5 m (5 ft.)		3.0 m (10 ft.)		4.5 m (15 ft.)		6.0 m (20 ft.)		7.5 m (25 ft.)	
	Over Front	Over Side	Over Front	Over Side	Over Front	Over Side	Over Front	Over Side	Over Front	Over Side
<i>With 2-piece boom; front blade and rear outriggers down</i>										
6.0 m (20 ft.)							3990 (8,790)	3990 (8,790)		
4.5 m (15 ft.)					4770 (10,510)	4770 (10,510)	4290 (9,450)	4290 (9,450)		
3.0 m (10 ft.)			8680 (19,130)	8680 (19,130)	6340 (13,970)	6340 (13,970)	4970 (10,960)	4600 (10,150)	4070 (8,980)	(6,850)
1.5 m (5 ft.)			10 580 (23,330)	10 580 (23,330)	7920 (17,470)	7040 (15,530)	5730 (12,640)	4570 (10,080)	4710 (10,390)	3040 (6,710)
Ground Line	8810 (19,420)	8810 (19,420)	12 700 (28,000)	12 700 (28,000)	8840 (19,490)	7090 (15,630)	6290 (13,860)	4580 (10,090)	4830 (10,640)	2930 (6,470)
-1.5 m (-5 ft.)	14 160 (31,210)	14 160 (31,210)	14 610 (32,210)	14 270 (31,470)	9070 (19,990)	7310 (16,120)	6490 (14,310)	4340 (9,560)		
-3.0 m (-10 ft.)	23 430 (51,650)	23 430 (51,650)	15 050 (33,190)	14 980 (33,020)	9400 (20,730)	6930 (15,280)	5930 (13,080)	4170 (9,190)		

With 2-piece boom; front outriggers and rear outriggers down

6.0 m (20 ft.)							3990 (8,790)	3990 (8,790)		
4.5 m (15 ft.)					4770 (10,510)	4770 (10,510)	4290 (9,450)	4290 (9,450)		
3.0 m (10 ft.)			8680 (19,130)	8680 (19,130)	6340 (13,970)	6340 (13,970)	4970 (10,960)	4970 (10,960)	4070 (8,980)	3620 (7,980)
1.5 m (5 ft.)			10 580 (23,330)	10 580 (23,330)	7920 (17,470)	7920 (17,470)	5730 (12,640)	5190 (11,440)	4710 (10,390)	3560 (7,840)
Ground Line	8810 (19,420)	8810 (19,420)	12 700 (28,000)	12 700 (28,000)	8840 (19,490)	8090 (17,840)	6290 (13,860)	5270 (11,620)	4830 (10,640)	3460 (7,620)
-1.5 m (-5 ft.)	14 160 (31,210)	14 160 (31,210)	14 610 (32,210)	14 610 (32,210)	9070 (19,990)	8310 (18,310)	6490 (14,310)	5080 (11,210)		
-3.0 m (-10 ft.)	23 430 (51,650)	23 430 (51,650)	15 050 (33,190)	15 050 (33,190)	9400 (20,730)	8210 (18,100)	5930 (13,080)	4910 (10,830)		

Buckets

A full line of buckets is offered to meet a wide variety of applications. Digging forces are with power boost. Buckets are equipped with John Deere TK-Series Bucket Teeth standard. Replaceable cutting edges and a variety of teeth are available through John Deere Parts. Optional side cutters add 150 mm (6 in.) to bucket widths. Capacities are SAE heaped ratings.

Type Bucket	Bucket Width		Bucket Capacity		Bucket Weight	
	mm	in.	m ³	cu. yd.	kg	lb.
General Purpose	610	24	0.39	0.5	442	970
	762	30	0.54	0.7	498	1,100
Heavy Duty	914	36	0.69	0.9	561	1,240
	1067	42	0.85	1.1	602	1,330
Ditching	1219	48	1.00	1.3	659	1,450
	1524	60	1.18	1.5	546	1,200

Additional equipment

Key: ● Standard ▲ Optional or special

See your John Deere dealer for further information.

190G Engine	
●	Auto-idle system
●	Automatic belt-tension device
●	Batteries (2 – 12 volt)
●	Coolant recovery tank
●	Dual-element dry-type air filter
●	Electronic engine control
●	Enclosed fan guard (conforms to SAE J1308)
●	Engine coolant to –37 deg. C (–34 deg. F)
●	Fuel filter with water separator
●	Full-flow oil filter
●	Turbocharger with charge-air cooler
●	500-hour engine-oil-change interval
●	Programmable auto-shutdown
Hydraulic System	
●	Reduced-drift valve for boom down, arm in
●	Auxiliary hydraulic valve section
●	Brake valves for travel circuits
●	Individual control of outriggers
●	Hydraulic filter restriction indicator
●	Spring-applied, hydraulically released automatic swing brake
●	Auxiliary hydraulic-flow adjustment through monitor
●	Auto power lift
●	5,000-hour hydraulic-oil-change interval
●	Auxiliary hydraulic lines with hand-controlled proportional control
▲	Control-pattern change valve
Undercarriage	
●	Brakes, 4 wheel, maintenance free, wet disc
●	Creeper speed range
●	Front axle, oscillating, lockable
▲	Front blade and rear outriggers (2)
▲	Outriggers (4)
●	Parking brake
●	Dual traction-type tires, 10.00-20, 16PR with spacer
●	Toolbox on left chassis

190G Upperstructure	
●	Right- and left-hand mirrors
●	Vandal locks with ignition key: Cab door / Fuel cap / Service doors
Front Attachments	
●	6.2-m (20 ft. 4 in.) monoblock boom with 2.71-m (8 ft. 11 in.) arm
▲	Variable-geometry, 2-piece boom with 2.71-m (8 ft. 11 in.) arm
●	Centralized lubrication system
●	Dirt seals on all bucket pins
▲	Buckets: Ditching / General purpose / General-purpose high capacity / Heavy duty / Heavy-duty high capacity / Side cutters and teeth
Operator's Station	
●	Adjustable independent-control positions (levers-to-seat, seat-to-pedals)
●	AM/FM radio
●	Auto climate control/air conditioner with heater and pressurizer
●	Built-in Operator's Manual storage compartment and manual
●	Cell-phone power outlet, 12 volt
●	Coat hook
●	Deluxe suspension cloth seat with 100-mm (4 in.) adjustable armrests
●	Floor mat
●	Front windshield wiper with intermittent speeds
●	Gauges (illuminated): Engine coolant / Fuel level / Speedometer
●	Horn, electric
●	Hour meter, electric
●	Hydraulic shutoff lever, all controls
●	Hydraulic warm-up control
●	Interior light
●	Large cup holder
●	Machine Information Center (MIC)
●	Mode selectors (illuminated): Power modes (3) / Work mode (1)
●	High/low travel mode with creeper range

190G Operator's Station (continued)	
●	Multifunction, color LCD monitor with: Diagnostic capability / Multiple-language capabilities / Maintenance tracking / Clock / In-monitor adjustment of auxiliary pressure and flow / System monitoring with alarm features: Auto-idle indicator, Auto-shutdown indicator, brake pressure audible alarm, engine air cleaner restriction indicator light, engine check, engine coolant temperature indicator light with audible alarm, engine oil pressure indicator light with audible alarm, low-alternator-charge indicator light, low-fuel indicator light, fault-code alert indicator, fuel-rate display, water-in-fuel light, wiper-mode indicator, work-lights-on indicator, and work-mode indicator
●	Motion alarm with cancel switch (conforms to SAE J994)
●	Power-boost switch on right control lever
●	SAE 2-lever control pattern
●	Seat belt, 76 mm (3 in.), non-retractable
●	Tinted glass
●	Transparent tinted overhead hatch
●	Tilting steering column
●	Sun visor
●	Windshield washer/wiper with constant and intermittent speeds
▲	Window vandal-protection covers
Electrical	
●	50-amp alternator
●	Blade-type multi-fused circuits
●	Positive-terminal battery covers
●	JDLink™ wireless communication system (available in specific countries; see your dealer for details)
●	Rearview camera
Lights	
●	Headlights (2)
●	Worklights, top of cab (2), rear of cab (1), and boom (1)
●	Turn signals / Hazard lights
●	Brake lights
●	Side marker lights

Net engine power is with standard equipment including air cleaner, exhaust system, alternator, and cooling fan at test conditions specified per ISO 9249. No derating is required up to 3050-m (10,000 ft.) altitude. Specifications and design subject to change without notice. Wherever applicable, specifications are in accordance with SAE standards. Except where otherwise noted, these specifications are based on a unit with 1.38-m³ (1.81 cu. yd.), 1219-mm (48 in.), 735-kg (1,621 lb.) bucket, 2.71-m (8 ft. 11 in.) arm, full fuel tank, and 75-kg (165 lb.) operator.

