

DOCUMENT 00101 – INVITATION TO BID

PROJECT: 2022 –Roofing Projects

LOCATION: Argentine Middle, J.C. Harmon High, Kansas City Kansas Early Childhood Center, New Stanley Elementary, NCO – Building A, Sumner Academy, Washington High, and Wyandotte High.

OWNER: Unified School District #500

The Owner will receive sealed bids until the bid time and date at the location given below for the following Work: Roof Replacement on miscellaneous buildings as listed in Specification Documents.

BID SUBMITTAL AND BID SECURITY

The Owner will consider bids as listed above, prepared in compliance with the Instructions to Bidders issued by the Owner, and delivered as follows:

Bid Date: December 16, 2021

Bid Time: 1:00 p.m., local time

Location: Bids to be mailed or hand delivered to the following address:

Attn: Mr. Wayne Correll, Director - Purchasing

2010 North 59th Street

Third Floor – Conservatory Room

Kansas City, Kansas 66104

Faxed bids are not acceptable.

The Owner (USD #500) reserves the right to accept or reject any and all bids and reserves the right to final judgment as to awarding the bid.

PRE-BID CONFERENCE

A pre-bid conference for all bidders will be held at District Maintenance Shop, 2220 N. 59th, Suite 229, Kansas City, Kansas 66104 on November 29, 2021, at 9:00 a.m., local time and November 30, 2021, at 9:00. All prospective bidders are required to attend.

- Monday, November 29, 2021, we will walk the roofs at North Central Office, Kansas City Kansas Early Childhood Center, J.C. Harmon High, Argentine Middle and New Stanley Elementary.
- Tuesday, November 30, 2021, we will start at Washington High and proceed to Wyandotte High, and Sumner Academy.

DOCUMENTS

Bidding documents may be obtained on the district web site. [Vendor Registry - KCKPS Solicitations](https://vrapp.vendorregistry.com/Bids/View/BidsList?BuyerId=c00af89d-f6af-4f0e-b823-f145c898cc06)
<https://vrapp.vendorregistry.com/Bids/View/BidsList?BuyerId=c00af89d-f6af-4f0e-b823-f145c898cc06>

TIME OF COMPLETION

Bidders shall begin work upon receipt of Notice to Proceed and to complete the work within the Contract Time indicated in the Contract Documents.

BIDDER'S QUALIFICATIONS

Bidders must be properly licensed under the state laws governing their respective trades and be able to obtain insurance and bonds required for the Work.

END OF SECTION 00101

Kansas City, Kansas Public Schools

Project Manual

2022 Summer *Roof Replacement & Restoration Projects*



November 17, 2021

USD #500
2010 North 59th Street
Kansas City, KS 66114

DOCUMENT 00201 – INSTRUCTIONS TO BIDDERS

1.1 ADVERTISEMENT FOR BIDS

- A. An Invitation to Bid, published as a separate document, is part of these instructions.

1.2 DEFINITIONS

- A. Bidding Documents include the Bidding Requirements and the proposed Contract Documents. The Bidding Requirements consist of the Advertisement for Bids, these Instructions to Bidders, bid forms, and other sample bidding and contract forms. The proposed Contract Documents consist of the form of Agreement between the Owner and Contractor, Conditions of the Contract, Drawings, Specifications, and all Addenda issued prior to execution of the Contract.
- B. Addenda are written, or graphic instruments issued by the Owner prior to the execution of the Contract that modify or interpret the Bidding Documents.
- C. The Base Bid is the sum stated in the Bid for which the Bidder offers to perform the Work described in the Bidding Documents as the base, to which Work may be added or from which Work may be deleted for sums stated in Alternate Bids.
- D. An Alternate Bid is an amount stated in the Bid to be added to or deducted from the amount of the Base Bid if the corresponding change in the Work, as described in the Bidding Documents, is accepted.
- E. A Unit Price is an amount stated in the Bid as a price per unit of measurement for materials, equipment, or services, or a portion of the Work as described in the Bidding Documents.
- F. A Bidder is a person or entity who submits a Bid to the Owner and who meets the requirements set forth in the Bidding Documents.

1.3 BIDDING DOCUMENTS

- A. Obtaining Bidding Documents: Bidders may obtain complete sets of the Bidding Documents from the issuing office designated in the Advertisement for Bids in the number and for the cost or deposit sum, if any, stated therein. Bidders shall use complete sets of Bidding Documents in preparing Bids. The Owner assumes no responsibility for errors or misinterpretations resulting from the use of incomplete sets of Bidding Documents.
- B. Examination of Bidding Documents and Site: Before submitting a bid, the Bidder shall carefully examine the drawings, read the specifications and all other Contract Documents and visit the site of the Work. The Bidder shall fully inform himself prior to bidding as to all existing conditions and limitations under which the Work is to be performed and he/she shall include in the Bid a sum to cover the cost of all items necessary to perform the Work as set forth in the Contract Documents. No allowance will be made to the Bidder because of lack of such examination or knowledge. The submission of a bid shall be construed as conclusive evidence that the Bidder has made such examination.

- C. Interpretation or Correction of Bidding Documents: If the Bidder is in doubt as to the interpretation of any part of the Bidding Documents or finds discrepancies in or omissions from any part of the Contract Documents, he/she must submit a written Request for Interpretation thereof not later than 7 days prior to opening of bids. Address all communications to the Owner.

1.4 ADDENDA

- A. Any interpretation, correction to, or addition to the Contract Documents will be made by written Addendum and will be delivered by mail or fax to each prime Bidder of record and the plan services indicated in the Advertisement for Bids. The written Addenda constitute the only interpretations of the Contract Documents; the Owner accepts no responsibility for any other claimed interpretations.
- B. It is the responsibility of each Bidder to verify that he/she has received all Addenda prior to submitting a bid. It is also the responsibility of each Bidder to verify that all sub-Bidders and material suppliers whose prices are incorporated in the Bidder's bid are familiar with the Bidding Documents in their entirety, including all Addenda issued up to the time of bid opening.
- C. In the event a conflict or omission is discovered in the Bidding Documents after the issuing of the last addendum such that an interpretation cannot be issued by the Owner prior to bidding, the Bidder is directed to estimate on and provide the quantity and quality of material and labor consistent with the overall represented work so as to provide all materials, equipment, labor, and services necessary for the completion of the Work.

1.5 SUBSTITUTIONS DURING BIDDING

- A. Substitutions are not allowed during bidding. Bids shall be submitted based upon the materials, equipment, and services specified.

1.6 BIDDING PROCEDURES

- A. Form Of Bid
 - 1. Bids must be submitted on the Bid Form provided, properly executed and with all items filled out in ink or typed. Do not change or add words to the Bid Form. Unauthorized conditions, limitations, or provisions on or attached to the Bid Form may be cause for rejection of the bid. Bidder's information on the Bid Form that is altered by erasure or by interlineation prior to submittal must be initialed and explained by notation on the Bid Form above the signature of the Bidder. All signatures must be witnessed.
- B. Submission Of Bids
 - 1. Each bid shall be delivered to the location indicated on the Bid Form on or before the day and hour set for receipt and opening of bids. Each bid shall be submitted in an opaque, sealed envelope marked in the lower left-hand corner as follows:

Bid for (name of prime contract)

Name of Project

Bidder's Name

Bidder's Address	_____
Contractor's License No.	_____
Date and Time of Bid Opening	_____

2. If not delivered in person, this envelope shall be enclosed in a second envelope for posting to the location indicated for receipt of bids. This envelope shall be addressed as follows:

Bid for (name of prime contract)	_____
Owner name	_____
Street address OR Post Office Box 0000	_____
City Name, State, Zip Code	_____
Contractor's License No.	_____
Date and Time of Bid Opening	_____

3. It is the sole responsibility of the Bidder to see that his/her bid is received in proper time. No bids submitted after the time fixed for receiving bids will be considered; late bids will be returned to the Bidder unopened.

C. Acknowledgement Of Addenda

1. Bidder must acknowledge all Addenda received in the spaces provided on the Bid Form. By submitting a bid, Bidder indicates that all considerations issued by addendum are incorporated in the bid.

D. Bid Supplements

1. Attached to the Bid Form will be certain supplements that are included in this Project Manual following the Bid Form. Bidders shall complete all forms, entering "Not Applicable" where information does not apply to their portion of the Work. Absence of any of the Bid Supplements included in the Project Manual will be reason for possible rejection of bid.

E. Status Of Bidders

1. Proprietors submitting bids shall indicate their status as proprietors.
2. Bidders submitting bids for partnerships shall indicate their status as partners and shall submit, upon request of the Owner within 24 hours following receipt of bids, a certified copy of the power of attorney authorizing the executor of the bid to bind the partnership.
3. Bidders submitting bids for corporations shall indicate their status as corporations and shall submit, upon request of the Owner within 24 hours following receipt of bids, a certified copy of the board of directors' authorization for the Bidder to bind the corporation and shall affix the corporate seal on the bid.
4. Bidders shall provide, upon request of the Owner, within 24 hours following receipt of bids, the following:
 - a. Names and addresses of proprietors, of all members of a partnership, or of the corporation's officers.
 - b. Name of county or state where the partnership is registered or where the corporation is incorporated. Corporations must be licensed to do business in the project state at the time of executing the contract.

1.7 MODIFICATION AND WITHDRAWAL OF BIDS

- A. A bid may be withdrawn on personal requests received from Bidder prior to submission time. A withdrawn bid may be resubmitted up to submission time. Negligence or error on the part of the Bidder in preparing his/her bid confers no right for withdrawal of the bid after it has been opened.
- B. Telegraphic and faxed bids will not be considered.
- C. No Bidder may withdraw a bid within 60 days following the opening of bids.

1.8 AWARD OR REJECTION OF BIDS

- A. The contract, if awarded, will be awarded to the lowest responsible Bidder, subject to the Owner's right to reject any or all bids and to waive any informality in the bids or in the bidding. Failure to complete all information required on the Bid Form and Bid Form Supplements, may result in rejection of bid. The Owner shall have the right to accept alternates in any order or combination, unless otherwise specifically provided in the Bidding Documents, and to determine the low bidder on the basis of the sum of the Base Bid and Alternates accepted.
- B. Bids may be rejected if the Bid Form shows any unexplained erasures, omissions, alterations of form, additions not called for, added restrictions or qualifying conditions or other irregularities of any kind.
- C. The Owner may make such investigations as he/she deems necessary to determine the ability of the Bidder to perform the Work, and the Bidder shall furnish to the Owner all such information for this purpose as the Owner may request. The Owner reserves the right to reject any bid if the evidence submitted by or investigation of such Bidder fails to satisfy the Owner that such Bidder is properly qualified to carry out the obligations of the Contract and to complete the Work contemplated therein within the Contract Time.

1.9 ACCEPTANCE

- A. The acceptance of a bid will be a Notice of Award, signed by a duly authorized representative of the Owner; no other act by the Owner or his/her agents shall constitute the acceptance of a bid. The acceptance of a bid by the Owner shall bind the successful Bidder to execute the contract. The Bidder to whom the contract is awarded by the Owner, shall, sign and deliver to the Owner for execution by the Owner all required copies of the Agreement, along with all required insurance and bonding documents. The rights and obligations provided for in the Contract shall become effective upon the parties only with formal execution of the Agreement by the Owner.

1.10 BONDS AND CERTIFICATES

- A. Bid shall be accompanied by an acceptable bid bond or certified cashier's check drawn on a local bank, payable to Treasurer, Board of Education, for an amount not less than five percent of the total amount of the bid. This bid security shall become the property of the Board of Education as liquidated damages in the event the successful bidder fails to execute and deliver a

contract, along with specified surety and statutory bonds, within ten days after the received notice of the acceptance of his bid by the Board of Education.

- B. Bidder shall deliver to the Owner, upon receipt of contract or purchase order, a Performance Bond, a Payment Bond, and a Labor and Material Bond, each in the amount of 100 percent of the Contract Sum, with a corporate surety authorized to transact business in the Project State, within 3 days following execution of the Contract, or prior to commencement of the Work, whichever occurs first. Attorneys-in-fact who sign bonds must file with each bond a certified and effective dated copy of their power of attorney.
- C. Satisfactory certificates of insurance in the amounts specified in the Contract Documents shall be furnished prior to commencement of Work.
- D. All bonds and policies or certificates of insurance must meet with the approval of the Owner before the Contractor will be allowed to commence the Work. Failure or refusal to furnish bonds or insurance policies or certificates in a form satisfactory to the Owner shall subject the Bidder(s) to forfeiture of bid bond.
- E. The form of the Agreement that the successful Bidder, as Contractor, will be required to execute is the form of Agreement referenced in the Project Manual.

1.11 INVOICING AND OFFICE SUPPORT

- A. All bidders must have the ability within their office to process all required paperwork for invoicing the district. This is to include, but not be limited to, timely issuance of invoices with proper backup to support the amount due, certified payrolls/reports, and all required closeout documents.
- B. Invoices may be emailed IF the contents of the email contain a cover letter with the invoice amount and all necessary support backup for the total amount due.
- C. All tax exempt "completion forms" must be provided to the District within the State of Kansas required timeframe. Violation of this process point might negate the tax-free benefit of working with the district.

1.12 LATE FEES

- A. Late Fees: In the event Contractor Fails to complete the work in accordance with the Schedule specified in the Agreement or within such additional time(s) as may be granted by formal written action of the District, District will charge a late fee. It is agreed that the Contractor shall pay to the district as fixed late fees, the sum of **\$1,500** USD for each calendar day after specified completion date until work is completed and accepted by District. Contractor and its Surety shall be liable for late fees assessed by District.

END OF SECTION 00201

DOCUMENT 00411 – BID FORM

USD #500
2022 – Argentine Middle School
Kansas City, Kansas

Bidder: _____
(Bidder enter name here)

BASE BID OR ALTERNATE BID, SINGLE-PRIME (ALL TRADES) CONTRACT

The undersigned Bidder, having carefully examined the Bidding and Contract Requirements, Conditions of the Contract, Drawings, Specifications, and all subsequent Addenda, all as issued by the Owner, having visited the site, and being familiar with all conditions and requirements of the Work, hereby agrees to furnish all material (other than roofing material listed on Attachment A), labor, equipment and services as described in the above documents, without exception, including all scheduled Allowances if any, necessary to complete the specified work.

USD #500 shall purchase all roofing material supplied by the primary roofing material manufacturer. The Bidder shall provide Attachment A with their bid, verifying quantities required to complete this project as specified. All materials not listed on Attachment A shall be the responsibility of the Bidder. The cost for the items listed on Attachment A shall not be included in Bidders Base Bid price. Failure to provide the mandatory Attachment A with verified quantities will render your bid non-responsive.

Single Prime (All trades) Contract for the above-named Project, in accordance with the requirements of the Bidding Documents, for the sum of:

BASE BID

- 1. Argentine Middle School
Roof Replacement - Roofs K, L, & M \$ _____

UNIT PRICES

- 1. Wood Blocking Replacement \$ _____ per board foot
- 2. Drain Bowl Replacement – 4” \$ _____ each
- 3. Drain Clamping Ring Replacement \$ _____ each
- 4. Concrete Deck Repair \$ _____ per cubic foot
- 5. 18-gauge Metal – Flat stock \$ _____ per square foot

WORKING DAYS

- Days to complete 100% of work specified _____ Working Days
- Anticipated days for roofers _____ Working Days
- Anticipated days for sheet metal _____ Working Days

BONDING

Bid shall be accompanied by an acceptable bid bond or certified cashier's check drawn on a local bank, payable to Treasurer, Board of Education, for an amount not less than five percent of the total amount of the bid. This bid security shall become the property of the Board of Education as liquidated damages in the event the successful bidder fails to execute and deliver a contract, along with specified surety and statutory bonds, within ten days after the received notice of the acceptance of his bid by the Board of Education.

The undersigned Bidder agrees to furnish a Payment & Performance Bond, in the amount of 100% of total contract value after receipt of contract.

TIME OF COMPLETION

The undersigned Bidder proposes and agrees hereby to commence the Work of these Contract Documents on June 1, 2022 and shall complete 100% of the Roofing and Sheet Metal Work no later than August 5, 2022. Work is defined as continuous daily roofing related activities as provided in this specification. If Work cannot be started or completed within specified timeframe, contractor shall provide immediate repairs to stop or minimize leaks until work is completed and shall pay as a late fee the sum of \$1,500 for each consecutive calendar day that work is not started or completed thereafter.

The district reserves the right to cancel the contract if the contractor has not started the work by June 3, 2022. All cost associated with the cancelling of the contract shall be the responsibility of the contractor, including any cost associated with returning materials purchase by the district.

If contractor fails to complete the work by August 5, 2022, all remaining work must be completed on weekends or holidays, and the district shall deduct \$1,500 per day from the contract until work is 100% complete.

ACKNOWLEDGEMENT OF ADDENDA

The undersigned Bidder acknowledges receipt of and use of the following Addenda in the preparation of this Bid:

Addendum No. 1, dated _____

Addendum No. 2, dated _____

Addendum No. 3, dated _____

CONTRACTOR'S LICENSE

The undersigned further states that he is a duly licensed Contractor, for the type of work proposed, in the State of Kansas, and that all fees, permits, etc., pursuant to the submission of this proposal will be paid in full.

SUBMISSION OF BID

Respectfully submitted this ____ day of _____, 2021.

By: _____

(Name of bidding firm or corporation)

Witness:

By: _____

(Signature)

Attest: _____

(Signature)

(Type or print name)

By: _____

(Type or print name)

Title: _____

(Owner/Partner/President/Vice Pres.)

Title: _____

(Corporate Secretary or Assistant Secretary Only)

Address: _____

Phone: _____

License: _____

(Affix Corporate Seal Here)

Federal ID No.: _____

ATTACHMENT A
USD #500 – 2022 ROOFING PROJECT
Argentine Middle – Roofs K, L, & M

<u>Products</u>	<u>Material Size & Container</u>	<u>Material Quantity</u>	
Alumanation 301	5-gallon bucket	TBD	buckets
Burmastic	50-gallon barrels - lined	TBD	barrels
Burmastic Composite Ply HT	20 rolls per pallet - 2/sq/roll	TBD	rolls
Burmastic Glass Ply 33-lbs.	20 rolls per pallet – 2/sq/roll	TBD	rolls
Burmesh	6” x 300’ rolls	TBD	rolls
ELS	5-gal buckets	TBD	buckets
Polyroof LV	5-gallon buckets	TBD	buckets
Premium IV Asphalt	24 cartons per pallet	TBD	cartons
TRA Flashing	18” x 50’ roll	TBD	rolls
	24” x 50’ roll	TBD	rolls
TremPrime QD	5-gallon bucket	TBD	buckets
TremSeal Pro – Bronze	30 tubes per case	TBD	cases

Contractor Name: _____

Project Size: _____ square feet

END OF SECTION 00411

DOCUMENT 00411 – BID FORM

USD #500
2022 – J.C. Harmon High School
Kansas City, Kansas

Bidder: _____
(Bidder enter name here)

BASE BID OR ALTERNATE BID, SINGLE-PRIME (ALL TRADES) CONTRACT

The undersigned Bidder, having carefully examined the Bidding and Contract Requirements, Conditions of the Contract, Drawings, Specifications, and all subsequent Addenda, all as issued by the Owner, having visited the site, and being familiar with all conditions and requirements of the Work, hereby agrees to furnish all material (other than roofing material listed on Attachment A), labor, equipment and services as described in the above documents, without exception, including all scheduled Allowances if any, necessary to complete the specified work.

USD #500 shall purchase all roofing material supplied by the primary roofing material manufacturer. The Bidder shall provide Attachment A with their bid, verifying quantities required to complete this project as specified. All materials not listed on Attachment A shall be the responsibility of the Bidder. The cost for the items listed on Attachment A shall not be included in Bidders Base Bid price. Failure to provide the mandatory Attachment A with verified quantities will render your bid non-responsive.

Single Prime (All trades) Contract for the above-named Project, in accordance with the requirements of the Bidding Documents, for the sum of:

BASE BID

- 1. J.C. Harmon High School
Roof Replacement - Roof 10 \$ _____

UNIT PRICES

- 1. Wood Blocking Replacement \$ _____ per board foot
- 2. Drain Bowl Replacement – 4” \$ _____ each
- 3. Drain Clamping Ring Replacement \$ _____ each
- 4. Concrete Deck Repair \$ _____ per cubic foot
- 5. 18-gauge Metal – Flat stock \$ _____ per square foot

WORKING DAYS

- Days to complete 100% of work specified _____ Working Days
- Anticipated days for roofers _____ Working Days
- Anticipated days for sheet metal _____ Working Days

BONDING

Bid shall be accompanied by an acceptable bid bond or certified cashier's check drawn on a local bank, payable to Treasurer, Board of Education, for an amount not less than five percent of the total amount of the bid. This bid security shall become the property of the Board of Education as liquidated damages in the event the successful bidder fails to execute and deliver a contract, along with specified surety and statutory bonds, within ten days after the received notice of the acceptance of his bid by the Board of Education.

The undersigned Bidder agrees to furnish a Payment & Performance Bond, in the amount of 100% of total contract value after receipt of contract.

TIME OF COMPLETION

The undersigned Bidder proposes and agrees hereby to commence the Work of these Contract Documents on June 1, 2022, and shall complete 100% of the Roofing and Sheet Metal Work no later than August 5, 2022. Work is defined as continuous daily roofing related activities as provided in this specification. If Work cannot be started or completed within specified timeframe, contractor shall provide immediate repairs to stop or minimize leaks until work is completed and shall pay as a late fee the sum of \$1,500 for each consecutive calendar day that work is not started or completed thereafter.

The district reserves the right to cancel the contract if the contractor has not started the work by June 3, 2022. All cost associated with the cancelling of the contract shall be the responsibility of the contractor, including any cost associated with returning materials purchase by the district.

If contractor fails to complete the work by August 5, 2022, all remaining work must be completed on weekends or holidays, and the District shall deduct \$1,500 per day from the contract until work is 100% complete.

ACKNOWLEDGEMENT OF ADDENDA

The undersigned Bidder acknowledges receipt of and use of the following Addenda in the preparation of this Bid:

Addendum No. 1, dated _____

Addendum No. 2, dated _____

Addendum No. 3, dated _____

CONTRACTOR'S LICENSE

The undersigned further states that he is a duly licensed Contractor, for the type of work proposed, in the State of Kansas, and that all fees, permits, etc., pursuant to the submission of this proposal will be paid in full.

SUBMISSION OF BID

Respectfully submitted this ____ day of _____, 2021.

By: _____

(Name of bidding firm or corporation)

Witness:

By: _____

(Signature)

Attest: _____

(Signature)

(Type or print name)

By: _____

(Type or print name)

Title: _____

(Owner/Partner/President/Vice Pres.)

Title: _____

(Corporate Secretary or Assistant Secretary Only)

Address: _____

Phone: _____

License: _____

(Affix Corporate Seal Here)

Federal ID No.: _____

ATTACHMENT A
USD #500 – 2022 ROOFING PROJECT
J.C. Harmon High – Roof 10

<u>Products</u>	<u>Material Size & Container</u>	<u>Material Quantity</u>	
Alumanation 301	5-gallon bucket	TBD	buckets
Burmastic	50-gallon barrels - lined	TBD	barrels
Burmastic Composite Ply HT	20 rolls per pallet - 2/sq/roll	TBD	rolls
Burmastic Glass Ply 33-lbs.	20 rolls per pallet – 2/sq/roll	TBD	rolls
Burmesh	6” x 300’ rolls	TBD	rolls
ELS	5-gal buckets	TBD	buckets
Polyroof LV	5-gallon buckets	TBD	buckets
Premium IV Asphalt	24 cartons per pallet	TBD	cartons
TRA Flashing	18” x 50’ roll	TBD	rolls
	24” x 50’ roll	TBD	rolls
TremPrime QD	5-gallon bucket	TBD	buckets
TremSeal Pro – Bronze	30 tubes per case	TBD	cases

Contractor Name: _____

Project Size: _____ square feet

END OF SECTION 00411

DOCUMENT 00411 – BID FORM

USD #500
2022 – Kansas City Kansas Early Childhood Center
Kansas City, Kansas

Bidder: _____
(Bidder enter name here)

BASE BID OR ALTERNATE BID, SINGLE-PRIME (ALL TRADES) CONTRACT

The undersigned Bidder, having carefully examined the Bidding and Contract Requirements, Conditions of the Contract, Drawings, Specifications, and all subsequent Addenda, all as issued by the Owner, having visited the site, and being familiar with all conditions and requirements of the Work, hereby agrees to furnish all material (other than roofing material listed on Attachment A), labor, equipment and services as described in the above documents, without exception, including all scheduled Allowances if any, necessary to complete the specified work.

USD #500 shall purchase all roofing material supplied by the primary roofing material manufacturer. The Bidder shall provide Attachment A with their bid, verifying quantities required to complete this project as specified. All materials not listed on Attachment A shall be the responsibility of the Bidder. The cost for the items listed on Attachment A shall not be included in Bidders Base Bid price. Failure to provide the mandatory Attachment A with verified quantities will render your bid non-responsive.

Single Prime (All trades) Contract for the above-named Project, in accordance with the requirements of the Bidding Documents, for the sum of:

BASE BID

- 1. Kansas City Kansas Early Childhood Center
Roof Replacement - Roofs 1, 2, 3, 4, 5, 6, and 7 \$ _____

UNIT PRICES

- 1. Wood Blocking Replacement \$ _____ per board foot
- 2. Wood Deck Repair \$ _____ per square foot
- 3. 18-gauge Metal – Flat stock \$ _____ per square foot

WORKING DAYS

- Days to complete 100% of work specified _____ Working Days
- Anticipated days for roofers _____ Working Days
- Anticipated days for sheet metal _____ Working Days

BONDING

Bid shall be accompanied by an acceptable bid bond or certified cashier's check drawn on a local bank, payable to Treasurer, Board of Education, for an amount not less than five percent of the total amount of the bid. This bid security shall become the property of the Board of Education as liquidated damages in the event the successful bidder fails to execute and deliver a contract, along with specified surety and

statutory bonds, within ten days after the received notice of the acceptance of his bid by the Board of Education.

The undersigned Bidder agrees to furnish a Payment & Performance Bond, in the amount of 100% of total contract value after receipt of contract.

TIME OF COMPLETION

The undersigned Bidder proposes and agrees hereby to commence the Work of these Contract Documents on June 1, 2022, and shall complete 100% of the Roofing and Sheet Metal Work no later than August 5, 2022. Work is defined as continuous daily roofing related activities as provided in this specification. If Work cannot be started or completed within specified timeframe, contractor shall provide immediate repairs to stop or minimize leaks until work is completed and shall pay as a late fee the sum of \$1,500 for each consecutive calendar day that work is not started or completed thereafter.

The district reserves the right to cancel the contract if the contractor has not started the work by June 3, 2022. All cost associated with the cancelling of the contract shall be the responsibility of the contractor, including any cost associated with returning materials purchase by the district.

If contractor fails to complete the work by August 5, 2022, all remaining work must be completed on weekends or holidays, and the District shall deduct \$1,500 per day from the contract until work is 100% complete.

ACKNOWLEDGEMENT OF ADDENDA

The undersigned Bidder acknowledges receipt of and use of the following Addenda in the preparation of this Bid:

Addendum No. 1, dated _____

Addendum No. 2, dated _____

Addendum No. 3, dated _____

CONTRACTOR'S LICENSE

The undersigned further states that he is a duly licensed Contractor, for the type of work proposed, in the State of Kansas, and that all fees, permits, etc., pursuant to the submission of this proposal will be paid in full.

SUBMISSION OF BID

Respectfully submitted this ____ day of _____, 2021.

By: _____

(Name of bidding firm or corporation)

Witness:

By: _____

(Signature)

Attest: _____
(Signature)

(Type or print name)

By: _____
(Type or print name)

Title: _____
(Owner/Partner/President/Vice Pres.)

Title: _____
(Corporate Secretary or Assistant Secretary Only)

Address: _____

Phone: _____

License: _____

(Affix Corporate Seal Here)

Federal ID No.: _____

ATTACHMENT A
USD #500 – 2022 ROOFING PROJECT
KCK Early Childhood Center – Roofs 1 - 7

<u>Products</u>	<u>Material Size & Container</u>	<u>Material Quantity</u>	
Alumanation 301	5-gallon bucket	TBD	buckets
Burmastic	50-gallon barrels - lined	TBD	barrels
Burmastic Composite Ply HT	20 rolls per pallet - 2/sq/roll	TBD	rolls
Burmastic Glass Ply 33-lbs.	20 rolls per pallet – 2/sq/roll	TBD	rolls
Burmesh	6” x 300’ rolls	TBD	rolls
ELS	5-gal buckets	TBD	buckets
Polyroof LV	5-gallon buckets	TBD	buckets
Premium IV Asphalt	24 cartons per pallet	TBD	cartons
TRA Flashing	18” x 50’ roll	TBD	rolls
	24” x 50’ roll	TBD	rolls
TremPrime QD	5-gallon bucket	TBD	buckets
TremSeal Pro – Bronze	30 tubes per case	TBD	cases

Contractor Name: _____

Project Size: _____ square feet

END OF SECTION 00411

DOCUMENT 00411 – BID FORM

USD #500
2022 – NCO – Building A
Kansas City, Kansas

Bidder: _____
(Bidder enter name here)

BASE BID OR ALTERNATE BID, SINGLE-PRIME (ALL TRADES) CONTRACT

The undersigned Bidder, having carefully examined the Bidding and Contract Requirements, Conditions of the Contract, Drawings, Specifications, and all subsequent Addenda, all as issued by the Owner, having visited the site, and being familiar with all conditions and requirements of the Work, hereby agrees to furnish all material (other than roofing material listed on Attachment A), labor, equipment and services as described in the above documents, without exception, including all scheduled Allowances if any, necessary to complete the specified work.

USD #500 shall purchase all roofing material supplied by the primary roofing material manufacturer. The Bidder shall provide Attachment A with their bid, verifying quantities required to complete this project as specified. All materials not listed on Attachment A shall be the responsibility of the Bidder. The cost for the items listed on Attachment A shall not be included in Bidders Base Bid price. Failure to provide the mandatory Attachment A with verified quantities will render your bid non-responsive.

Single Prime (All trades) Contract for the above-named Project, in accordance with the requirements of the Bidding Documents, for the sum of:

BASE BID

- 1. NCO - Building A
Roof Replacement - Roofs 1 and 2 \$ _____

UNIT PRICES

- 1. Wood Blocking Replacement \$ _____ per board foot
- 2. Drain Bowl Replacement – 5” \$ _____ each
- 3. Drain Clamping Ring Replacement \$ _____ each
- 4. Concrete Deck Repair \$ _____ per cubic foot
- 5. 18-gauge Metal – Flat stock \$ _____ per square foot

WORKING DAYS

- Days to complete 100% of work specified _____ Working Days
- Anticipated days for roofers _____ Working Days
- Anticipated days for sheet metal _____ Working Days

BONDING

Bid shall be accompanied by an acceptable bid bond or certified cashier's check drawn on a local bank, payable to Treasurer, Board of Education, for an amount not less than five percent of the total amount of the bid. This bid security shall become the property of the Board of Education as liquidated damages in the event the successful bidder fails to execute and deliver a contract, along with specified surety and statutory bonds, within ten days after the received notice of the acceptance of his bid by the Board of Education.

The undersigned Bidder agrees to furnish a Payment & Performance Bond, in the amount of 100% of total contract value after receipt of contract.

TIME OF COMPLETION

The undersigned Bidder proposes and agrees hereby to commence the Work of these Contract Documents on June 1, 2022, and shall complete 100% of the Roofing and Sheet Metal Work no later than August 5, 2021. Work is defined as continuous daily roofing related activities as provided in this specification. If Work cannot be started or completed within specified timeframe, contractor shall provide immediate repairs to stop or minimize leaks until work is completed and shall pay as a late fee the sum of \$1,500 for each consecutive calendar day that work is not started or completed thereafter.

The district reserves the right to cancel the contract if the contractor has not started the work by June 3, 2022. All cost associated with the cancelling of the contract shall be the responsibility of the contractor, including any cost associated with returning materials purchase by the district.

If contractor fails to complete the work by August 5, 2022, all remaining work must be completed on weekends or holidays, and the District shall deduct \$1,500 per day from the contract until work is 100% complete.

ACKNOWLEDGEMENT OF ADDENDA

The undersigned Bidder acknowledges receipt of and use of the following Addenda in the preparation of this Bid:

Addendum No. 1, dated _____

Addendum No. 2, dated _____

Addendum No. 3, dated _____

CONTRACTOR'S LICENSE

The undersigned further states that he is a duly licensed Contractor, for the type of work proposed, in the State of Kansas, and that all fees, permits, etc., pursuant to the submission of this proposal will be paid in full.

SUBMISSION OF BID

Respectfully submitted this ____ day of _____, 2021

By: _____

(Name of bidding firm or corporation)

Witness:

By: _____

(Signature)

Attest: _____

(Signature)

(Type or print name)

By: _____

(Type or print name)

Title: _____

(Owner/Partner/President/Vice Pres.)

Title: _____

(Corporate Secretary or Assistant Secretary Only)

Address: _____

Phone: _____

License: _____

(Affix Corporate Seal Here)

Federal ID No.: _____

ATTACHMENT A
USD #500 – 2022 ROOFING PROJECT
NCO – Building A – Roofs 1 and 2

<u>Products</u>	<u>Material Size & Container</u>	<u>Material Quantity</u>	
Alumanation 301	5-gallon bucket	TBD	buckets
Burmastic Adhesive	50-gallon barrels - lined	TBD	pallets
Burmastic Composite Ply HT	20 rolls per pallet - 2/sq/roll	TBD	rolls
Burmastic Glass Ply 33-lbs.	20 rolls per pallet – 2/sq/roll	TBD	rolls
Burmesh	6” x 300’ rolls	TBD	rolls
ELS	5-gal buckets	TBD	buckets
Polyroof LV	5-gallon buckets	TBD	buckets
Premium IV Asphalt	24 cartons per pallet	TBD	cartons
TRA Flashing	18” x 50’ roll	TBD	rolls
TremPrime QD	5-gallon bucket	TBD	buckets
TremSeal Pro – Bronze	30 tubes per case	TBD	cases

Contractor Name: _____

Project Size: _____ square feet

END OF SECTION 00411

DOCUMENT 00411 – BID FORM

USD #500
2022 – New Stanley Elementary School
Kansas City, Kansas

Bidder: _____
(Bidder enter name here)

BASE BID OR ALTERNATE BID, SINGLE-PRIME (ALL TRADES) CONTRACT

The undersigned Bidder, having carefully examined the Bidding and Contract Requirements, Conditions of the Contract, Drawings, Specifications, and all subsequent Addenda, all as issued by the Owner, having visited the site, and being familiar with all conditions and requirements of the Work, hereby agrees to furnish all material (other than roofing material listed on Attachment A), labor, equipment and services as described in the above documents, without exception, including all scheduled Allowances if any, necessary to complete the specified work.

USD #500 shall purchase all roofing material supplied by the primary roofing material manufacturer. The Bidder shall provide Attachment A with their bid, verifying quantities required to complete this project as specified. All materials not listed on Attachment A shall be the responsibility of the Bidder. The cost for the items listed on Attachment A shall not be included in Bidders Base Bid price. Failure to provide the mandatory Attachment A with verified quantities will render your bid non-responsive.

Single Prime (All trades) Contract for the above-named Project, in accordance with the requirements of the Bidding Documents, for the sum of:

BASE BID

1. New Stanley Elementary School
Roof Replacement - Roof 1 \$ _____

UNIT PRICES

- 1. Wood Blocking Replacement \$ _____ per board foot
- 2. Wood Deck Repair \$ _____ per square foot
- 3. 18-gauge Metal – Flat stock \$ _____ per square foot

WORKING DAYS

Days to complete 100% of work specified _____ Working Days
 Anticipated days for roofers _____ Working Days
 Anticipated days for sheet metal _____ Working Days

BONDING

Bid shall be accompanied by an acceptable bid bond or certified cashier's check drawn on a local bank, payable to Treasurer, Board of Education, for an amount not less than five percent of the total amount of the bid. This bid security shall become the property of the Board of Education as liquidated damages in the event the successful bidder fails to execute and deliver a contract, along with specified surety and

statutory bonds, within ten days after the received notice of the acceptance of his bid by the Board of Education.

The undersigned Bidder agrees to furnish a Payment & Performance Bond, in the amount of 100% of total contract value after receipt of contract.

TIME OF COMPLETION

The undersigned Bidder proposes and agrees hereby to commence the Work of these Contract Documents on June 1, 2022, and shall complete 100% of the Roofing and Sheet Metal Work no later than August 5, 2022. Work is defined as continuous daily roofing related activities as provided in this specification. If Work cannot be started or completed within specified timeframe, contractor shall provide immediate repairs to stop or minimize leaks until work is completed and shall pay as a late fee the sum of \$1,500 for each consecutive calendar day that work is not started or completed thereafter.

The district reserves the right to cancel the contract if the contractor has not started the work by June 3, 2022. All cost associated with the cancelling of the contract shall be the responsibility of the contractor, including any cost associated with returning materials purchase by the district.

If contractor fails to complete the work by August 5, 2022, all remaining work must be completed on weekends or holidays, and the district shall deduct \$1,500 per day from the contract until work is 100% complete.

ACKNOWLEDGEMENT OF ADDENDA

The undersigned Bidder acknowledges receipt of and use of the following Addenda in the preparation of this Bid:

Addendum No. 1, dated _____

Addendum No. 2, dated _____

Addendum No. 3, dated _____

CONTRACTOR'S LICENSE

The undersigned further states that he is a duly licensed Contractor, for the type of work proposed, in the State of Kansas, and that all fees, permits, etc., pursuant to the submission of this proposal will be paid in full.

SUBMISSION OF BID

Respectfully submitted this ____ day of _____, 2021.

By: _____

(Name of bidding firm or corporation)

Witness:

By: _____

(Signature)

Attest: _____
(Signature)

(Type or print name)

By: _____
(Type or print name)

Title: _____
(Owner/Partner/President/Vice Pres.)

Title: _____
(Corporate Secretary or Assistant Secretary Only)

Address: _____

Phone: _____

License: _____

(Affix Corporate Seal Here)

Federal ID No.: _____

ATTACHMENT A
USD #500 – 2022 ROOFING PROJECT
New Stanley Elementary – Roof 1

<u>Products</u>	<u>Material Size & Container</u>	<u>Material Quantity</u>	
Alumanation 301	5-gallon bucket	TBD	buckets
Burmastic	50-gallon barrels - lined	TBD	barrels
Burmastic Composite Ply HT	20 rolls per pallet - 2/sq/roll	TBD	rolls
Burmastic Glass Ply 33-lbs.	20 rolls per pallet – 2/sq/roll	TBD	rolls
Burmesh	6” x 300’ rolls	TBD	rolls
ELS	5-gal buckets	TBD	buckets
Polyroof LV	5-gallon buckets	TBD	buckets
Premium IV Asphalt	24 cartons per pallet	TBD	cartons
TRA Flashing	18” x 50’ roll 24” x 50’ roll	TBD 9TBD	rolls rolls
TremPrime QD	5-gallon bucket	TBD	buckets
TremSeal Pro – Bronze	30 tubes per case	TBD	cases

Contractor Name: _____

Project Size: _____ square feet

END OF SECTION 00411

DOCUMENT 00411 – BID FORM

USD #500
2022 – Sumner Academy
Kansas City, Kansas

Bidder: _____
(Bidder enter name here)

BASE BID OR ALTERNATE BID, SINGLE-PRIME (ALL TRADES) CONTRACT

The undersigned Bidder, having carefully examined the Bidding and Contract Requirements, Conditions of the Contract, Drawings, Specifications, and all subsequent Addenda, all as issued by the Owner, having visited the site, and being familiar with all conditions and requirements of the Work, hereby agrees to furnish all material (other than roofing material listed on Attachment A), labor, equipment and services as described in the above documents, without exception, including all scheduled Allowances if any, necessary to complete the specified work.

USD #500 shall purchase all roofing material supplied by the primary roofing material manufacturer. The Bidder shall provide Attachment A with their bid, verifying quantities required to complete this project as specified. All materials not listed on Attachment A shall be the responsibility of the Bidder. The cost for the items listed on Attachment A shall not be included in Bidders Base Bid price. Failure to provide the mandatory Attachment A with verified quantities will render your bid non-responsive.

Single Prime (All trades) Contract for the above-named Project, in accordance with the requirements of the Bidding Documents, for the sum of:

BASE BID

- 1. Sumner Academy
Roof Replacement - Roofs 13 and 29 \$ _____

- 2. Sumner Academy
Roof Restoration -
Roofs 17, 17A, 17B, 18, 20, 21, & 26 \$ _____

UNIT PRICES

- 1. Wood Blocking Replacement \$ _____ per board foot
- 2. Drain Bowl Replacement – 4” \$ _____ each
- 3. Drain Clamping Ring Replacement \$ _____ each
- 4. Concrete Deck Repair \$ _____ per cubic foot
- 5. 18-gauge Metal – Flat stock \$ _____ per square foot

WORKING DAYS

Days to complete 100% of work specified in Base Bid _____ Working Days
 Anticipated days for roofers _____ Working Days
 Anticipated days for sheet metal _____ Working Days

BONDING

Bid shall be accompanied by an acceptable bid bond or certified cashier's check drawn on a local bank, payable to Treasurer, Board of Education, for an amount not less than five percent of the total amount of the bid. This bid security shall become the property of the Board of Education as liquidated damages in the event the successful bidder fails to execute and deliver a contract, along with specified surety and statutory bonds, within ten days after the received notice of the acceptance of his bid by the Board of Education.

The undersigned Bidder agrees to furnish a Payment & Performance Bond, in the amount of 100% of total contract value after receipt of contract.

TIME OF COMPLETION

The undersigned Bidder proposes and agrees hereby to commence the Work of these Contract Documents on June 1, 2022 and shall complete 100% of the Roofing and Sheet Metal Work no later than August 5, 2022. Work is defined as continuous daily roofing related activities as provided in this specification. If Work cannot be started or completed within specified timeframe, contractor shall provide immediate repairs to stop or minimize leaks until work is completed and shall pay as a late fee the sum of \$1,500 for each consecutive calendar day that work is not started or completed thereafter.

The district reserves the right to cancel the contract if the contractor has not started the work by June 3, 2022. All cost associated with the cancelling of the contract shall be the responsibility of the contractor, including any cost associated with returning materials purchase by the district.

If contractor fails to complete the work by August 5, 2022 all remaining work must be completed on weekends or holidays, and the district shall deduct \$1,500 per day from the contract until work is 100% complete.

ACKNOWLEDGEMENT OF ADDENDA

The undersigned Bidder acknowledges receipt of and use of the following Addenda in the preparation of this Bid:

Addendum No. 1, dated _____

Addendum No. 2, dated _____

Addendum No. 3, dated _____

CONTRACTOR'S LICENSE

The undersigned further states that he is a duly licensed Contractor, for the type of work proposed, in the State of Kansas, and that all fees, permits, etc., pursuant to the submission of this proposal will be paid in full.

SUBMISSION OF BID

Respectfully submitted this ____ day of _____, 2021

By: _____

(Name of bidding firm or corporation)

Witness:

By: _____
(Signature)

Attest: _____
(Signature)

(Type or print name)

By: _____
(Type or print name)

Title: _____
(Owner/Partner/President/Vice Pres.)

Title: _____
(Corporate Secretary or Assistant Secretary Only)

Address: _____

Phone: _____

License: _____

(Affix Corporate Seal Here)

Federal ID No.: _____

ATTACHMENT A
USD #500 – 2022 ROOFING PROJECT
Sumner Academy – Roofs 13 & 28

<u>Products</u>	<u>Material Size & Container</u>	<u>Material Quantity</u>	
Alumanation 301	5-gallon bucket	TBD	buckets
Burmastic	50-gallon barrels - lined	TBD	barrels
Burmastic Composite Ply HT	20 rolls per pallet - 2/sq/roll	TBD	rolls
Burmastic Glass Ply 33-lbs.	20 rolls per pallet – 2/sq/roll	TBD	rolls
Burmesh	6” x 300’ rolls	TBD	rolls
ELS	5-gal buckets	TBD	buckets
Polyroof LV	5-gallon buckets	TBD	buckets
Premium IV Asphalt	24 cartons per pallet	TBD	cartons
TRA Flashing	18” x 50’ roll 24” x 50’ roll	TBD 9TBD	rolls rolls
TremPrime QD	5-gallon bucket	TBD	buckets
TremSeal Pro – Bronze	30 tubes per case	TBD	cases

Contractor Name: _____

Project Size: _____ square feet

ATTACHMENT A
USD #500 – 2022 ROOFING PROJECT
Sumner Academy
**Roof Restoration – Roofs 17, 17A, 17B, 18, 20, 21,
and 26**

<u>Products</u>	<u>Material Size & Container</u>	<u>Material Quantity</u>	
AlphaGuard Bio Base Coat	4-gallon kit	TBD	kits
AlphaGuard Bio Top Coat	3.1-gallon kit	TBD	kits
Burmastic SF Adhesive	5-gallon bucket	TBD	buckets
Burmastic Composite Ply HT	20 rolls per pallet – 2/sq/roll	TBD	rolls
Burmesh	6” x 300’ rolls	TBD	roll
Ecolastic	53-gal lined barrels	TBD	barrels
ELS Mastic	5-gallon bucket	TBD	buckets
GeoGard Primer	1-gallon bucket	TBD	bucket
TRA Flashing	18” x 50’ roll 36” x 50’ roll	TBD TBD	rolls rolls
Permafab	4” x 300’ roll	TBD	roll
Polyroof SF	3-gallon bucket	TBD	buckets
TremPrime QD	5-gallon bucket	TBD	bucket
TremSeal Pro – Bronze	30 tubes per case	TBD	cases

Contractor Name: _____

Project Size: _____ square feet

END OF SECTION 00411

DOCUMENT 00411 – BID FORM

USD #500
2022 – Washington High School
Kansas City, Kansas

Bidder: _____
(Bidder enter name here)

BASE BID OR ALTERNATE BID, SINGLE-PRIME (ALL TRADES) CONTRACT

The undersigned Bidder, having carefully examined the Bidding and Contract Requirements, Conditions of the Contract, Drawings, Specifications, and all subsequent Addenda, all as issued by the Owner, having visited the site, and being familiar with all conditions and requirements of the Work, hereby agrees to furnish all material (other than roofing material listed on Attachment A), labor, equipment and services as described in the above documents, without exception, including all scheduled Allowances if any, necessary to complete the specified work.

USD #500 shall purchase all roofing material supplied by the primary roofing material manufacturer. The Bidder shall provide Attachment A with their bid, verifying quantities required to complete this project as specified. All materials not listed on Attachment A shall be the responsibility of the Bidder. The cost for the items listed on Attachment A shall not be included in Bidders Base Bid price. Failure to provide the mandatory Attachment A with verified quantities will render your bid non-responsive.

Single Prime (All trades) Contract for the above-named Project, in accordance with the requirements of the Bidding Documents, for the sum of:

BASE BID

- 1. Washington High School
Roof Replacement - Roofs 24, 27, 28, & 29 \$ _____

UNIT PRICES

- 1. Wood Blocking Replacement \$ _____ per board foot
- 2. Drain Bowl Replacement – 4” \$ _____ each
- 3. Drain Clamping Ring Replacement \$ _____ each
- 4. Concrete Deck Repair \$ _____ per cubic foot
- 5. 18-gauge Metal – Flat stock \$ _____ per square foot

WORKING DAYS

- Days to complete 100% of work specified _____ Working Days
- Anticipated days for roofers _____ Working Days
- Anticipated days for sheet metal _____ Working Days

BONDING

Bid shall be accompanied by an acceptable bid bond or certified cashier's check drawn on a local bank, payable to Treasurer, Board of Education, for an amount not less than five percent of the total amount of the bid. This bid security shall become the property of the Board of Education as liquidated damages in the event the successful bidder fails to execute and deliver a contract, along with specified surety and statutory bonds, within ten days after the received notice of the acceptance of his bid by the Board of Education.

The undersigned Bidder agrees to furnish a Payment & Performance Bond, in the amount of 100% of total contract value after receipt of contract.

TIME OF COMPLETION

The undersigned Bidder proposes and agrees hereby to commence the Work of these Contract Documents on June 1, 2022, and shall complete 100% of the Roofing and Sheet Metal Work no later than August 5, 2022. Work is defined as continuous daily roofing related activities as provided in this specification. If Work cannot be started or completed within specified timeframe, contractor shall provide immediate repairs to stop or minimize leaks until work is completed and shall pay as a late fee the sum of \$1,500 for each consecutive calendar day that work is not started or completed thereafter.

The district reserves the right to cancel the contract if the contractor has not started the work by June 3, 2022. All cost associated with the cancelling of the contract shall be the responsibility of the contractor, including any cost associated with returning materials purchase by the district.

If contractor fails to complete the work by August 5, 2022, all remaining work must be completed on weekends or holidays, and the district shall deduct \$1,500 per day from the contract until work is 100% complete.

ACKNOWLEDGEMENT OF ADDENDA

The undersigned Bidder acknowledges receipt of and use of the following Addenda in the preparation of this Bid:

Addendum No. 1, dated _____

Addendum No. 2, dated _____

Addendum No. 3, dated _____

CONTRACTOR'S LICENSE

The undersigned further states that he is a duly licensed Contractor, for the type of work proposed, in the State of Kansas, and that all fees, permits, etc., pursuant to the submission of this proposal will be paid in full.

SUBMISSION OF BID

Respectfully submitted this _____ day of _____, 2021.

By: _____

(Name of bidding firm or corporation)

Witness:

By: _____
(Signature)

Attest: _____
(Signature)

(Type or print name)

By: _____
(Type or print name)

Title: _____
(Owner/Partner/President/Vice Pres.)

Title: _____
(Corporate Secretary or Assistant Secretary Only)

Address: _____

Phone: _____

License: _____

(Affix Corporate Seal Here)

Federal ID No.: _____

ATTACHMENT A
USD #500 – 2022 ROOFING PROJECT
Washington High – Roofs 24, 27, 28, & 29

<u>Products</u>	<u>Material Size & Container</u>	<u>Material Quantity</u>	
Alumanation 301	5-gallon bucket	TBD	buckets
Burmastic	50-gallon barrels - lined	TBD	barrels
Burmastic Composite Ply HT	20 rolls per pallet - 2/sq/roll	TBD	rolls
Burmastic Glass Ply 33-lbs.	20 rolls per pallet – 2/sq/roll	TBD	rolls
Burmesh	6” x 300’ rolls	TBD	rolls
ELS	5-gal buckets	TBD	buckets
Polyroof LV	5-gallon buckets	TBD	buckets
Premium IV Asphalt	24 cartons per pallet	TBD	cartons
TRA Flashing	18” x 50’ roll 24” x 50’ roll	TBD TBD	rolls rolls
TremPrime QD	5-gallon bucket	TBD	buckets
TremSeal Pro – Bronze	30 tubes per case	TBD	cases

Contractor Name: _____

Project Size: _____ square feet

END OF SECTION 00411

DOCUMENT 00411 – BID FORM

USD #500
2022 – Wyandotte High
Kansas City, Kansas

Bidder: _____
(Bidder enter name here)

BASE BID OR ALTERNATE BID, SINGLE-PRIME (ALL TRADES) CONTRACT

The undersigned Bidder, having carefully examined the Bidding and Contract Requirements, Conditions of the Contract, Drawings, Specifications, and all subsequent Addenda, all as issued by the Owner, having visited the site, and being familiar with all conditions and requirements of the Work, hereby agrees to furnish all material (other than roofing material listed on Attachment A), labor, equipment and services as described in the above documents, without exception, including all scheduled Allowances if any, necessary to complete the specified work.

USD #500 shall purchase all roofing material supplied by the primary roofing material manufacturer. The Bidder shall provide Attachment A with their bid, verifying quantities required to complete this project as specified. All materials not listed on Attachment A shall be the responsibility of the Bidder. The cost for the items listed on Attachment A shall not be included in Bidders Base Bid price. Failure to provide the mandatory Attachment A with verified quantities will render your bid non-responsive.

Single Prime (All trades) Contract for the above-named Project, in accordance with the requirements of the Bidding Documents, for the sum of:

BASE BID

- 1. Wyandotte High
Roof Replacement - Roofs 16 and 17 \$ _____

- 2. Wyandotte High
Roof Replacement - Roof 20 \$ _____

UNIT PRICES

- 1. Wood Blocking Replacement \$ _____ per board foot
- 2. Drain Bowl Replacement – 4” \$ _____ each
- 3. Drain Clamping Ring Replacement \$ _____ each
- 4. Concrete Deck Repair \$ _____ per cubic foot
- 5. 18-gauge Metal – Flat stock \$ _____ per square foot

WORKING DAYS

Days to complete 100% of work specified in Base Bid _____ Working Days
 Anticipated days for roofers _____ Working Days
 Anticipated days for sheet metal _____ Working Days

BONDING

Bid shall be accompanied by an acceptable bid bond or certified cashier's check drawn on a local bank, payable to Treasurer, Board of Education, for an amount not less than five percent of the total amount of the bid. This bid security shall become the property of the Board of Education as liquidated damages in the event the successful bidder fails to execute and deliver a contract, along with specified surety and statutory bonds, within ten days after the received notice of the acceptance of his bid by the Board of Education.

The undersigned Bidder agrees to furnish a Payment & Performance Bond, in the amount of 100% of total contract value after receipt of contract.

TIME OF COMPLETION

The undersigned Bidder proposes and agrees hereby to commence the Work of these Contract Documents on June 1, 2022 and shall complete 100% of the Roofing and Sheet Metal Work no later than August 5, 2022. Work is defined as continuous daily roofing related activities as provided in this specification. If Work cannot be started or completed within specified timeframe, contractor shall provide immediate repairs to stop or minimize leaks until work is completed and shall pay as a late fee the sum of \$1,500 for each consecutive calendar day that work is not started or completed thereafter.

The district reserves the right to cancel the contract if the contractor has not started the work by June 3, 2022. All cost associated with the cancelling of the contract shall be the responsibility of the contractor, including any cost associated with returning materials purchase by the district.

If contractor fails to complete the work by August 5, 2022 all remaining work must be completed on weekends or holidays, and the district shall deduct \$1,500 per day from the contract until work is 100% complete.

ACKNOWLEDGEMENT OF ADDENDA

The undersigned Bidder acknowledges receipt of and use of the following Addenda in the preparation of this Bid:

Addendum No. 1, dated _____

Addendum No. 2, dated _____

Addendum No. 3, dated _____

CONTRACTOR'S LICENSE

The undersigned further states that he is a duly licensed Contractor, for the type of work proposed, in the State of Kansas, and that all fees, permits, etc., pursuant to the submission of this proposal will be paid in full.

SUBMISSION OF BID

Respectfully submitted this ____ day of _____, 2021

By: _____

(Name of bidding firm or corporation)

Witness:

By: _____
(Signature)

Attest: _____
(Signature)

(Type or print name)

By: _____
(Type or print name)

Title: _____
(Owner/Partner/President/Vice Pres.)

Title: _____
(Corporate Secretary or Assistant Secretary Only)

Address: _____

Phone: _____

License: _____

(Affix Corporate Seal Here)

Federal ID No.: _____

ATTACHMENT A
USD #500 – 2022 ROOFING PROJECT
Wyandotte High – Roofs 16 & 17

<u>Products</u>	<u>Material Size & Container</u>	<u>Material Quantity</u>	
Burmastic Composite Ply Premium	20 rolls per pallet - 2/sq/roll	TBD	rolls
Burmesh	6" x 300' roll	TBD	rolls
ELS	5-gal buckets	TBD	buckets
PowerPly Endure 300 FR Colonial Red	20 rolls per pallet – 1/sq./roll	TBD	rolls
Premium IV Asphalt	24 cartons per pallet	TBD	cartons
TremSeal Pro – Bronze	30 tubes per case	TBD 1	cases

Contractor Name: _____

Project Size: _____ square feet

ATTACHMENT A
USD #500 – 2022 ROOFING PROJECT
Wyandotte High – Roof 20

<u>Products</u>	<u>Material Size & Container</u>	<u>Material Quantity</u>	
Alumanation 301	5-gallon bucket	TBD	buckets
Burmastic	50-gallon barrels - lined	TBD	barrels
Burmastic Composite Ply HT	20 rolls per pallet - 2/sq/roll	TBD	rolls
Burmastic Glass Ply 33-lbs.	20 rolls per pallet – 2/sq/roll	TBD	rolls
Burmesh	6” x 300’ rolls	TBD	rolls
ELS	5-gal buckets	TBD	buckets
Polyroof LV	5-gallon buckets	TBD	buckets
Premium IV Asphalt	24 cartons per pallet	TBD	cartons
TRA Flashing	18” x 50’ roll	TBD	rolls
	24” x 50’ roll	TBD	rolls
TremPrime QD	5-gallon bucket	TBD	buckets
TremSeal Pro – Bronze	30 tubes per case	TBD	cases

Contractor Name: _____

Project Size: _____ square feet

END OF SECTION 00411

SECTION 01100 – SUMMARY

PART 1 - GENERAL

1.1 RELATED DOCUMENTS

- A. Drawings and general provisions of the Contract, including General and Supplementary Conditions and other Division 1 Specification Sections, apply to this Section.

1.2 SUMMARY

- A. This Section includes the following:
 - 1. Work covered by the Contract Documents.
 - 2. Type of the Contract.
 - 3. Work phases.
 - 4. Use of premises.
 - 5. Owner's occupancy requirements.
 - 6. Work restrictions.
 - 7. Specification formats and conventions.

1.3 WORK COVERED BY CONTRACT DOCUMENTS

- A. Project Identification:
 - 1. Argentine Middle – Roofs K, L, and M – Roof Replacement
 - 2. J.C. Harmon High – Roof 10 – Roof Replacement
 - 3. KCK Early Childhood Center – Roofs 1 thru 7 – Roof Retrofit
 - 4. New Stanley Elementary – Roof 1 – Roof Replacement
 - 5. NCO Building A – Roofs 1 and 2 – Roof Replacement
 - 6. Sumner Academy
 - a. Roofs 13 and 29 – Roof Replacement
 - b. Roofs 17, 17A, 17B, 18, 20, 21, & 26 - Roof Restoration
 - 7. Washington High – Roofs 24, 27, 28, and 29 – Roof Replacement
 - 8. Wyandotte High – Roofs 16, 17 and 20 – Roof Replacement
- B. Owner: Kansas City Kansas Public Schools - (USD #500)
 - 1. Owner's Representative: Doug Clements 913-627-3863 and Denny Brake 913-549-7135.
- C. The Work consists of the following:
 - 1. General conditions and details for all roof areas:
 - a. Any roofing or sheet metal work not completed by the date stated in these specification documents shall only be completed during non-school hours.
 - 1) Non-school hours: Monday through Friday Evenings after 4:00 P.M. or Saturdays and Sundays.
 - b. All prime and sub-contractors must follow all owner and OSHA safety guidelines.
 - c. The district has implemented the following Job Site Safety & Risk Mitigation Requirements and Policies.

- 1) The job site staging area surrounding the cranes, forklifts, kettles, ORI's, job boxes, and all equipment and tools shall be secured by a minimum eight-foot chain link fence prior to start of work, and the district must approve prior to job start.
 - 2) Any axes, shovels, picks, brooms, ladders or other tools or equipment found on the grounds surrounding the work site and not secured inside the chain link fence or job box shall justify a \$500 penalty per occurrence to be deducted from final payment.
 - 3) Any ropes extending from the roof or ladder wheels, accessible from the ground while the contractor is not on site shall justify a \$500 penalty per occurrence to be deducted from final payment.
 - 4) The use of roof chuggers shall not be allowed on roof replacement projects with gypsum, lightweight concrete, or tectum decks unless approved in writing by the district prior to the start of the project.
 - 5) Contractors are responsible for damages to any electrical conduit on the underside of decks.
- d. Prime Contractor shall supply a submittal package including; Site Specific Safety Plan, Schedule of Work, Drain Test Report, list of sub-contractors, and Sheet Metal drawings prior to start of work.
- 1) Safety Plan shall show a site plan locating kettle, security fence, roof access points, cranes, dumpsters, ORIs, material storage, and any other equipment being supplied and used by contractor throughout the duration of the project.
 - 2) District shall review and approve submittal package within 10-working days.
 - 3) Submittal must be submitted to the district no later than two weeks prior to staging of project. District will approve or reject package within 7 days after submittal package has been received.
- e. Prime Contractor shall always keep complete roofing specification and approved submittal drawing on the roof during the work.
- 1) If required paperwork is not present on the roof, the project may be immediately shut down at Districts discretion.
 - a) All cost associate with such shut downs shall be the contractor's responsibility.
- f. The prime contractor shall use any subcontractor for their base and alternate bids if their sub-contractors are licensed in the State of Kansas and Wyandotte County for the specific job requirements and approved by district.
- 1) Prime Contractor shall provide the district with a list of their sub-contractors with their submittal package.
 - 2) Any sub-contractor not meeting the state, county, and district requirements shall not be allowed on the project.
- g. It is the responsibility of the contractor to provide 100% supervision of the kettle at all times when hot adhesives are in use.
- 1) It is the districts requirements that the kettle person have a minimum of 5-years' experience monitoring and regulating the temperature controls on a kettle.
- h. It is the districts requirements that all project Foreman have a minimum of 5-years' experience installing roofing system similar to specified system.
- 1) Documentation showing work history, as a Foreman, shall be provided to district in their submittal package and approved by district prior to job start.
 - 2) If Foreman does not have 5-years' experience installing similar roofing system, contractor shall pay for full-time inspection by the roofing material manufacturer's representative.

- i. After receipt of all roofing materials listed on Attachment A Form, contractor shall provide the district a letter stating they have received all materials, which shall be secure and stored on their property.
- j. The contractor shall include in their bids the cost to remove and re-install all drain clamping rings at the end of each day's work.
- k. It is the responsibility of the contractor to report in writing to the district, any areas of cracks or deterioration to the masonry walls above the roofline.
- l. It is the responsibility of the contractor for all underside clean up from drippage and debris coming through the roof deck.
- m. It is the responsibility of the contractor to provide a sub-contractor to water test all existing drains prior to starting the projects and at the completion of the projects.
 - 1) Contractor shall water test all drains using a standard ¾" hose running full on for a minimum of 10-minutes per drain.
 - 2) Contractor shall verify that the primary roof drains, overflow roof drains, and plumbing vents located within the project area are free of debris, damage, and properly functioning. The contractor shall perform a flood test of existing roof drain bowls and connections to piping by temporarily plugging the drain pipe below the existing connection and flooding the drain bowl to its top edge. Notify the Owner immediately if defects or damages are found in the roof drain bowl and/or roof drain assembly components, or if the roof drains and/or plumbing vents are found to be blocked, clogged, or otherwise not properly functioning. Any plumbing work necessary to correct identified defects, and clear existing roof drains and vents shall be performed by a licensed plumber at the direction of the Owner. Prior to start of work, the contractor shall provide a letter to the Owner indicating this work has been completed, detailing the results of this roof drain inspection and testing, and identifying any corrective action needed.
 - 3) After completion of roofing work, the prime contractor shall again obtain the services of a licensed plumbing contractor to verify that primary roof drains, overflow roof drains and plumbing vents located within the project area are free of debris and properly functioning. The plumber shall perform a second flood test of existing roof drains located in the project areas. The flood test shall include the same testing as completed prior to the roofing work. Continue to flood the roof drain, up and over the installed roof drain flashing. Notify the prime contractor and Owner immediately if defects are found in the roof drain flashing, roof drain bowl and/or roof drain assembly components, or if the roof drains and/or plumbing vents are found to be blocked, clogged, or otherwise not properly functioning. Plumbing work necessary to correct identified defects, and clear existing roof drains and vents shall be performed by a licensed plumber at the direction of the Owner and paid for by the prime contractor. After construction completion, the contractor shall provide a second letter to the Owner indicating this work has been completed, detailing the results of this roof drain inspection and testing, and identifying any corrective action needed.
- n. It is the responsibility of the contractor to examine the job site and document any damages or issues with pictures and/or video.
 - 1) Any damages found after start of work will be the responsibility of the contractor.
 - 2) Contractor shall submit all videos and pictures to Owner with their submittal package prior to job start.

- o. It is the responsibility of the contractor to add or remove perimeter and projection wood blocking and adjust drain height as needed to accommodate new roof system.
- p. It is the responsibility of the contractor to clean roofs, drains, gutters, and scuppers of all debris and trash at the end of the project and prior to the expiration of their two-year warranty.
 - 1) Cleaning shall include the removal of all gravel in gutters, drain sumps, and scupper sumps.
 - 2) Two-year obligation shall also include tightening all drain bolts.
 - 3) Failure to provide this work shall end the contractor's approval to bid future work with the Owner.
- q. It is the contractor's responsibility to keep all RTU's clean and free of any roofing material, personal items, or debris.
 - 1) RTU's shall not be used to store tools, lunchboxes, or any items related to the project.
- r. It is the contractor's responsibility to disconnect and raise all electrical conduit and gas lines and extend plumbing pipes as needed to complete work per specifications and meet all local building codes.
 - 1) All lines shall be supported by new specified supports and hangers.
 - 2) No lines shall be supported directly on outside walls, expansion joints, or other equipment.
 - 3) During work, contractor shall properly support lines with wood blocking as needed to complete work and eliminate any damage to lines.
 - a) Any damage found after project shall be the responsibility of the contractor to repair and/or replace as owner approves.
- s. Prime contractor shall provide a Work Schedule for the months of June and July showing their anticipated work plan for the project.
 - 1) The Work Schedule shall be updated weekly and provided to the district.
 - 2) A Work Schedule shall be provided to the district with their submittal package.
- t. Prime contractor shall provide a weekly written progress report to include what days were worked and if days were not worked why.
 - 1) Progress report shall be provided to the district on a weekly basis or project will be shut down.
 - 2) A sample progress report shall be provided to the district with their submittal package.
- u. Drains:
 - 1) Adjust the height of all drains as needed to accommodate new roof system.
 - 2) Sump all drains a minimum of 48" x 48" with 1/2" slope per foot.
 - 3) Replace all broken or missing drain strainers with new cast iron strainers that will properly fit drain ring.
 - 4) Install 30" x 30" four-pound lead flashing into drain and strip-in with 2-ply of trilaminate felt and/or 2-ply of smooth and granular MB membrane set in cold asphalt mastic, or as required by roofing material manufacturer.
 - a) Adhere lead in a solid application of cold mastic.
 - 5) Replace any broken or missing drain clamping rings and bolts.
 - 6) Drain plugs shall be installed in all drains prior to roof removal.
 - a) All drain plugs shall be removed, and drains cleared at the end of each day.
 - b) Any drain or drain pipe joint leak found after completion of project, and not documented as leaking prior to job start, shall be the

- responsibility of the contractor to repair and/or replace as determined by owner.
- 7) Install metal gravel dam around all drain sumps.
 - v. Remove obsolete equipment and projections as indicated by owner during pre-bid meeting.
 - 1) Cover voids in decks with minimum 16-gauge flat metal panels or matching metal deck.
 - a) Provide additional structural support on underside as required by local and state building codes.
 - w. As needed, raise and extend projection curbs and pipes, expansion/control joints, and perimeters to accommodate new insulation height and provide a minimum eight-inch flashing height.
 - 1) Add or remove wood blocking as needed to accommodate new tapered insulation at perimeter and projection details.
 - x. Replace deteriorated wood blocking at perimeters and projections as needed.
 - 1) Provide unit cost per board foot.
 - 2) New wood blocking shall not be installed on ends.
 - 3) All blocking shall be securely fastened and approved by owner and roofing material manufacturer.
 - y. Repair deck as needed. (Provide unit cost)
 - 1) District's representative and/or roofing manufacturer representative shall be notified and allowed to verify deck repair and/or replacement.
 - z. Adhere fiberboard cants at all projection base flashing locations as required by roofing material manufacturer.
 - aa. Adhere fiberboard or polyisocyanurate cricket on high side of projections to eliminate any ponding water.
 - 1) Adhere as required by roofing material manufacturer.
 - bb. At all perimeter and projection base flashing:
 - 1) Prime masonry walls prior to installing any base flashing.
 - cc. Base Flashing:
 - 1) All base flashings shall require a trilaminate backer sheet install with approved hot or cold adhesive prior to installing any finish flashing membrane.
 - 2) Adhere base flashing as required by roofing material manufacturer.
 - 3) Cold adhesives and mastic shall require adhesive to be installed on back side of flashing membrane and wall the flashing will adhere to.
 - 4) Horizontal flashing length shall not exceed 10'.
 - 5) Roll outside face of flashing membrane with steel roller to provide 100% positive adhesive.
 - a) Any voids found in the membrane shall require removal and replacement.
 - 6) Install bar termination at the top edge of all base flashing where the flashing is not wrapped over a curb, wall, or expansion joint.
 - a) Strip-in all bar terminations with 3-course of asphalt mastic and reinforcing mesh.
 - 7) Base flashing height shall be a minimum of eight-inches and shall not exceed twelve-inches.
 - 8) Flashing over twelve-inches shall be bar terminated and another flashing membrane wrapped over the above wall or projection and extended down past the bar termination a minimum of four-inches or install metal wall panels above base flashing.

- 9) Adhere fiberboard cant at all base flashing as required by roofing material manufacturer.
 - 10) Provide a 3-course strip-in at all vertical and horizontal flashing laps, horizontal edges, and corners of flashing with elastomeric asphalt mastic as required by roofing material manufacturer.
 - 11) Install specified counterflashing over termination bar. Termination bar shall always be covered with metal counterflashing a minimum of four inches.
 - 12) All brick walls shall require new 24-gauge pre-finished reglet joint counterflashing unless otherwise specified.
 - a) Width shall be sufficient to extend down over bar termination a minimum of four inches.
 - 13) New 24-gauge metal end covers, and 90-degree corners shall be installed to properly terminate ends of all sheet metal details.
 - 14) Owners' representative and roofing material manufacturer shall review and approve all completed flashing work prior to the installation of sheet metal.
- dd. Install fiberboard tapered edge strips as needed along perimeters and around projections to provide positive drainage.
- 1) Adhere tapered edge strips as required by roofing material manufacturer.
- ee. Insulation:
- 1) Any insulation being installed with low-rise foam insulation adhesive shall at a minimum have a bead of foam installed one inch from all outside edges.
 - 2) Stagger every layer of insulation a minimum of 24".
 - 3) Install staggered dead-man insulation tie-offs with dead-man being a minimum of 24" deep.
 - 4) Any insulation installed over a nailable deck, shall only mechanically fasten the base layer of insulation.
 - a) Base insulation layer shall not exceed three inches.
 - b) All layers above base layer shall be fully adhered with hot asphalt or cold insulation adhesive.
- ff. Install new 24-gauge pre-finished metal counterflashing skirt to all mechanical equipment curbs and vents.
- 1) The new skirt can be mechanically fastened or riveted to the existing curb flange with no back-water laps and shall extend down over the bar termination a minimum of four-inches.
- gg. All new coping shall be 24-gauge pre-finished and approved by owner and roofing manufacturer. (Owner to select color)
- 1) Outside and inside fascia width shall exceed and extend down past the existing fascia width unless otherwise specified.
 - 2) Install proper end closures and trims, approved by the roofing manufacturer, where terminating into concrete, brick, stucco, and/or metal walls.
 - 3) Provide a new 20-gauge continuous cleat on all copings.
 - 4) Slope the new coping to the inside by installing treated wood at the outside edge and covering top with treated 5/8" or thicker plywood.
 - 5) Any fascia over 6" shall have horizontal stiffening ribs every 6" o.c.
 - 6) Walls shall be completely wrapped (inside and outside) with new flashing or trillaminate base sheet prior to installing new coping.
 - a) Flashing or base sheet shall be nailed on the outside face of wood nailer to completely encapsulate and cover all wood.
- hh. Install new 24-gauge pre-finished gutters and downspouts as specified.
- 1) Gutter and downspout size shall be based on drainage area and shall follow local code requirements.

- a) Minimum 6" gutters and 4" x 5" downspouts.
- 2) Inside upper flange of gutter shall extend up over membrane covering perimeter felt and wood blocking.
- 3) If downspouts daylight at ground level, the bottom three feet shall be open faced design.
 - a) Downspouts draining into underground lines or piping shall be solid and provide appropriate metal transition connections at tie-in.
 - b) Any holes in the walls from previous downspout hangers and straps shall be sealed and watertight.
- 4) Provide new concrete splash blocks under each downspout.
 - a) If downspout is located on another roof, splash blocks shall have protection treads installed under them.
- 5) Any substrate behind gutter shall be wrapped with new 22-gauge pre-finished metal prior to installing new gutters.
 - a) Fascia wrap shall be approved by owner's representative and roofing material manufacturer, and detail drawings shall be included in submittal package.
- ii. Install new 24-gauge pre-finished metal edge with gravel stop at all gutter edges.
 - 1) Set primed metal edge in solid bed of asphalt mastic over wood nailer.
 - 2) Mechanically fasten flange into wood blocking with approved fasteners every four inches on-center, two rows staggered.
 - 3) Strip in flange with two ply flashing system, consisting of trilaminate base sheet and granular surfaced modified bitumen membrane adhered in cold asphalt mastic.
 - a) Install metal gravel dam approximately 12" back from gutter, outside two-ply strip-in, and set metal flange in asphalt mastic. Do not attach or strip in metal dam.
 - b) Coat flashing between gravel dam and edge with specified flood coat and buckshot gravel surfacing.
 - 4) Outside fascia shall extend down over gutter flange a minimum of four inches.
- jj. Install metal gravel dams around all roof drains, scuppers, gutters, and overflows.
 - 1) Approximate gravel dam size 4' x 4' at drains, overflows, and scuppers.
 - 2) At gutters install approximately 12" from gutter edge.
 - 3) Adhere flange of dams in asphalt mastic.
 - 4) Do not attach or strip in flange of dams.
 - 5) V-cuts in metal dams shall extend to roof level.
 - 6) Cover sump areas with specified flood coat and buckshot gravel surface.
- kk. Install new 24-gauge pre-finished raised edge caps at all outside perimeters unless otherwise specified.
 - 1) Outside fascia width shall extend down past the existing fascia width a minimum of one inch unless otherwise specified.
 - 2) Install proper end closures and trims, approved by the roofing manufacturer, where terminating into concrete, brick, stucco, and/or metal walls.
 - 3) Provide a new 20-gauge continuous cleat on all copings.
 - 4) Fasten on inside slope of new metal with approved grommeted screws.
- ll. Install new 24-gauge pre-finished surface-mount counterflashing to all specified walls.
 - 1) Fasten to substrate 8" o.c. minimum with approved fasteners.
 - 2) Top edge shall provide a caulking lip.
 - a) Prime metal and wall prior to installing sealant

- b) Install sealant compatible to roof system and components.
- c) Sealant shall be tooled to eliminate any voids and shed water.
- 3) Any counterflashing skirt that is more than 6" wide will require a horizontal stiffening rib every 6" o.c.
- mm. Install new four-pound lead flashing sleeves over plumbing pipes and strip-in with two plies of trilaminate felt set in cold asphalt mastic.
 - 1) Adhere lead in solid application of asphalt mastic or as required by roofing material manufacturer.
 - 2) Plumbing pipe shall extend above finished roof a minimum of eight inches or more as required by local building codes.
- nn. Install new 24-gauge pitch pans and hoods around all electrical conduits, cooling pipes, equipment supports, and miscellaneous projections.
 - 1) Strip-in with two-plies of trilaminate felt set in cold asphalt mastic or as required by roofing material manufacturer.
 - 2) Fill pans with quick set grout to within 2" from top edge and let cure.
 - 3) Fill remainder of pan with dual component, solvent free, roofing sealant.
 - 4) Install 24-gauge sloped hoods over pans with sealant around projection.
 - 5) Install gooseneck hoods over pitch pans with multiple pipes.
- oo. Install new jacks and storm collars at all round vent stacks.
 - 1) Secure storm collar and seal with approved sealant.
 - 2) Strip-in with two plies of trilaminate felt set in cold asphalt mastic or as required by roofing material manufacturer.
- pp. At all scuppers, install new 24-gauge stainless steel scupper sleeves.
 - 1) Insulation around all scuppers shall be sumped 48" x 48".
 - a) Install metal gravel dams outside sump areas.
 - 2) Scupper sleeves shall be primed and set in a bed of elastomeric mastic.
 - 3) Secure interior flanges at top, bottom, and sides.
 - 4) Strip-in with two plies of trilaminate felt set in cold elastomeric mastic.
 - 5) Install new 24-gauge pre-finished scupper heads and downspouts.
 - a) Match size and shape of exiting scupper heads and downspouts unless otherwise specified or required larger by local building codes.
 - i) All scupper heads shall have a half-moon overflow opening in the outside face.
 - b) Install new scupper heads and downspouts at all drain line pipes extending out vertical walls.
 - c) New downspouts shall be 4" x 5" or match existing, whichever is bigger
 - i) Downspout shall be open-faced at bottom three feet.
 - d) Size of heads and downspouts shall meet building codes and owner's requirements.
 - 6) Provide new concrete splash blocks under each downspout.
- qq. At metal edge and gravel stop perimeters not changed to raised metal edge details, remove existing and install new 24-gauge pre-finished metal.
 - 1) Install 20-gauge continuous cleat.
 - 2) Outside fascia shall exceed the existing width and/or extend down over current termination point by a minimum of one inch.
 - 3) Inside horizontal flange shall be primed, set in a bed of asphalt mastic, fastened 4" staggered o.c. and striped in with 2-plies of trilaminate felt and cold asphalt mastic or as required by roofing material manufacturer.
 - 4) Metal edge details are only allowed at gutters. All existing metal edge details shall be changed to raised edge details. Contractors are responsible

- for adding new wood blocking as needed to be approved by roofing material manufacturer and Owner.
- rr. Roof access/staging points for gravel surfacing shall be protected with ¾" plywood cover a minimum of 128 sq. ft.
 - 1) Plywood shall be removed and roof area under the plywood shall be inspected by owner and roofing material manufacturer.
 - ss. Install hanger supports under gas and conduit lines that are 4" or wider. (Provide Owner with the hanger design prior to installation)
 - 1) Install rubber triangular support blocks at gas line supports and electrical conduit smaller than 4".
 - a) Install treated wood blocking to adjust height.
 - 2) Install protection treads under wood blocking supports, rubber blocks, and hanger support legs.
 - 3) Hanger supports shall meet or exceed PS-1-2 by PHP Systems & Design.
 - 4) All wood blocking supports for gas and electrical conduit shall be replaced with new Dura-Blok or hangers.
 - tt. Repair and replace all PVC condensate lines on RTU's.
 - 1) Any broken or missing PVC components, including pee-traps, shall be replaced.
 - 2) Extend all PVC drain lines out past RTU's a minimum of four feet towards the closest drainage point.
 - a) Attach PVC lines to wood blocking with u-clamps every 6' o.c.
 - uu. All wood supports shall be replaced with new treated wood with protection treads underneath, unless being replaced by other supports mentioned in specification.
 - 1) New wood shall not be installed on ends unless approved by owner and roofing material manufacturer.
 - 2) New wood will be utilized only under equipment support legs and where pipe block supports are not appropriate per roofing material manufacturer.
 - vv. Install protection treads outside the access panels to all RTU's, mechanical equipment, roof hatches, and roof access doors.
 - ww. Paint all base flashing, soil stacks, gas lines, drain strainers, drain sumps, and rusted equipment or sheet metal with two coats of aluminum reflective coating unless otherwise specified.
 - xx. Contractor shall provide Owner's Representative and roofing material manufacturer a completed Pre-Final Inspection Form prior to installing, flood coat and gravel, modified bitumen cap sheet, and/or any restoration coating material.
 - 1) After receipt of the Form, a meeting shall be scheduled to walk completed roof work.
 - 2) Only after the roof walk and approval by the Owner and roofing material manufacturer shall the contractor install the appropriate surfacing's and/or membranes.
 - 3) If the Form is not received and no roof walk is completed, the project will be rejected.
 - a) The contractor shall be responsible for all cost to remove surfacing's and/or membranes as needed for inspection of the underlying roof system.

2. Argentine Middle School

2123 Ruby Avenue
K.C., KS 66106

a. Roofs K, L, and M – Roof Replacement:

- 1) Tear off all roofing and insulation down to concrete deck.
 - a) Remove all metal details including scupper sleeves, scupper heads and downspouts.
 - b) Remove all obsolete equipment and curbs.
- 2) Remove all perimeter and projection flashing and metal terminations.
- 3) Prime concrete deck with asphalt primer.
- 4) Adhere trilaminate base sheet over concrete decks with hot Type IV asphalt.
- 5) Adhere 1/8" sloped tapered polyisocyanurate insulation over base sheet with hot Type IV asphalt.
 - a) Roof K – 4.5" start
 - b) Roof L – 3.5" start
 - c) Roof M – 3" start
- 6) Adhere 1/4" gypsum coverboard with hot Type IV asphalt.
- 7) Adhere 1-ply of trilaminate base sheet over coverboard with hot Type IV asphalt.
- 8) Adhere 3-ply of 33-lb. fiberglass felt in cold modified asphalt adhesive.
- 9) Adhere TRA base flashing to all perimeters and projection base flashing, with cold elastomeric asphalt mastic.
 - a) Adhere trilaminate backer sheet in elastomeric adhesive prior to TRA.
 - b) Strip-in all vertical and horizontal joints and ends with 3-course of elastomeric asphalt mastic and reinforcing mesh.
 - c) At elevation change on Roof M, treat as base flashing and install two ply flashing membrane. Install TRA prior to installing 3-ply on upper level.
- 10) Install new 24-gauge pre-finished reglet counterflashing at all brick walls.
- 11) At low walls with limestone coping, install a 24-gauge pre-finished L-shaped counterflashing under limestone coping.
- 12) Install new 22-gauge gravel dams around all scupper sumps.
 - a) Coat membrane between gravel dams and scuppers with two coats of aluminum reflective coating.
- 13) Install new 24-gauge stainless steel scupper sleeves and strip-in with two plies of trilaminate base sheet set in elastomeric adhesive.
 - a) Install 40" x 40" sump around all scuppers.
 - b) Install 24-gauge pre-finished scupper heads and downspouts.
 - c) Install new concrete splash blocks and protection treads under each downspout.
- 14) Over new roof membrane, install cold modified asphalt flood coat and Kunshek gravel surface.
- 15) Install two coats of aluminum reflective coating to all base flashing, plumbing pipes, drain sumps, rusted equipment, and drain strainers.
- 16) Install new Bilco roof hatch on Roof L
 - a) Match existing shape and size.

3. J.C. Harmon High School

2400 Steele Road
K.C., KS 66106

a. Roof 10 – Roof Replacement:

- 1) The district shall remove all security cameras prior to start of roofing work and reinstall after roofing and sheet metal work is complete.
- 2) Tear off all roofing and insulation down to concrete.
- 3) Remove all perimeter and projection flashing and metal terminations including copings, counterflashing's, and parapet wall coverings.
 - a) At sloped interior walls, cut and remove lower metal counterflashing and install new counterflashing after new flashings are installed.
- 4) Prime concrete deck with asphalt primer.
- 5) Adhere trilaminate base sheet over concrete decks with hot Type IV asphalt.
- 6) Adhere tapered polyisocyanurate insulation over base sheet with hot Type IV asphalt.
 - a) Slope: 1/8" per foot
 - b) Starting height: 2.0"
- 7) Adhere all tapered polyisocyanurate insulation with hot Type IV asphalt.
- 8) Adhere 1/4" gypsum coverboard with hot Type IV asphalt.
- 9) Adhere 1-ply of trilaminate base sheet over coverboard with hot Type IV asphalt.
- 10) Adhere 3-ply of 33-lb. fiberglass felt in cold modified asphalt adhesive.
- 11) Adhere TRA base flashing to all perimeters and projection base flashing with cold elastomeric asphalt mastic.
 - a) Adhere trilaminate backer sheet in elastomeric adhesive prior to TRA.
 - b) Strip-in all vertical and horizontal joints and ends with 3-course of elastomeric asphalt mastic and reinforcing mesh.
- 12) Install new 24-gauge pre-finished reglet counterflashing at all brick walls.
- 13) Install new 24-gauge pre-finished metal terminations at all perimeters and projections.
 - a) Install new coping along all outside perimeter walls.
 - b) Install new interior parapet wall covering where existing is removed along all outside perimeter walls. Match detail used on Roofs 2, 5, 12, and 13.
 - c) Install new counterflashing under sloped interior wall panels.
 - d) Install new wall expansion joint detail along the south wall.
- 14) Install new 24-gauge pre-finished counterflashing skirt under the wall vent counterflashing.
- 15) At the southwest corner, install 24-gauge pre-finished metal to transition into the brick walls and existing sloped metal wall panels.
- 16) Install new 22-gauge gravel dams around all drains. Dams must be outside of sumps.
 - a) Coat membrane between gravel dams and drains with two coats of aluminum reflective coating.
- 17) Over new roof membrane, install cold modified asphalt flood coat and Kunshek gravel surface.
- 18) Install new wood blocking supports and protection treads under wall vent legs.
- 19) Install protection tread under metal supports at large gooseneck vent.
- 20) Install two coats of aluminum reflective coating to all base flashing, plumbing pipes, drain sumps, rusted equipment, and drain strainers.

4. Kansas City Kansas Early Childhood Center

1709 N. 55th Street

K.C., KS 66201

a. Roofs 1, 2, 3, 4, 5, 6, and 7 – Roof Retrofit:

- 1) Remove all wet areas as shown on drawings and roof membrane down to the metal deck.
 - a) Sweep deck and flutes clean of all dirt, dust, and debris.
 - b) Mechanically fasten 2” base layer insulation over metal deck with one fastener every two square feet.
 - c) Adhere all remaining tapered insulation with hot asphalt.
 - i) New insulation must be flush with the top of the existing roof membrane.
- 2) Remove all perimeter and projection base flashing.
 - a) Leave copings, expansion joint covers, and counterflashing’s in place unless otherwise noted.
 - b) Cut and remove existing base flashing membrane at bottom edge of cant strip. Remove cant strip along with flashings.
 - c) Prime walls, projection curbs, and metal with asphalt primer prior to installing new flashings.
 - d) Remove all loose strip-in flashings around pitch pans, vent stacks, plumbing pipes, or any projection with a flange strip-in.
 - e) Remove lead flashing around plumbing and overflow drain pipes at membrane level. Install a three-course reinforcement around each pipe.
- 3) Remove sump area around drains, approximately 48” x 48”.
 - a) Remove all roofing material down to existing insulation.
- 4) Shave any ridges, buckles, or wrinkles in the existing TPO membrane, as needed to allow the new substrate gypsum board to lay flat.
- 5) Disconnect and raise any equipment, gas lines, and/or electrical conduit as needed to complete work.
 - a) Roofing contractor shall be responsible to provide a licensed electrical or mechanical contractor as needed.
- 6) Sweep existing roof membrane deck clean of all dirt, dust, and debris.
- 7) Mechanically fasten 0.5” x 4’ x 8’ primed gypsum substrate board over existing membrane with eight fasteners per board.
- 8) Adhere a second layer of 1/4” x 4’ x 4’ primed gypsum coverboard over base layer with hot asphalt.
- 9) Adhere new tapered cant strip along all base flashing with hot Type IV asphalt.
- 10) Adhere one ply of trilaminate base sheet over coverboard with hot Type IV asphalt.
- 11) Adhere 3-ply of 33-lb. fiberglass felt in cold modified asphalt adhesive.
- 12) Adhere TRA base flashing to all perimeters and projection base flashing with cold elastomeric asphalt mastic.
 - a) Adhere trilaminate backer sheet in elastomeric adhesive prior to TRA.
 - b) Strip-in all vertical and horizontal joints and ends with 3-course of elastomeric asphalt mastic and reinforcing mesh.
- 13) Install new 24-gauge pitch pans around existing pitch pans and strip-in with 2-ply of trilaminate felt in cold asphalt mastic.

- 14) Install new four-pound lead flashing around all drains, drain overflow pipes, and plumbing pipes.
 - a) Stirp-in with 2-ply of trilaminate felt in cold asphalt mastic.
- 15) Replace any loose, cracked, split, or missing caulking at existing perimeter and projection base flashing details.
- 16) Resecure any loose metal details with new grommeted screws and/or rivets.
- 17) Over new roof membrane, install cold modified asphalt flood coat and Kunshek gravel surface.
- 18) Install two coats of aluminum reflective coating to all base flashing, plumbing pipes, drain sumps, rusted equipment, and drain strainers.
- 19) Replace all existing wood blocking supports with new treated wood blocking and protection treads.

5. New Stanley Elementary School

3604 Metropolitan Avenue

K.C., KS 66106

a. Roof 1 – Roof Replacement:

- 1) Tear off all roofing and insulation down to wood deck.
 - a) Remove all perimeter and projection flashing and metal terminations including, interior metal wall covering, gutters, and downspouts.
 - b) Leave existing coping in place on east, west, and south parapet walls.
- 2) Sweep deck clean of all dirt, dust, and debris.
- 3) Mechanically fasten a red rosin sheet over the wood deck.
- 4) Mechanically fasten 1.8" thick polyisocyanurate insulation over wood deck with one fastener every two square feet.
- 5) Adhere 1/4" gypsum coverboard over polyisocyanurate insulation with hot Type IV asphalt.
- 6) Adhere trilaminate base sheet over coverboard with hot Type IV asphalt.
- 7) Adhere 3-ply of 33-lbs fiberglass ply sheets in cold modified asphalt adhesive.
- 8) Install TRA flashing at all perimeters and base flashing with elastomeric asphalt mastic.
 - a) Adhere trilaminate backer sheet in elastomeric adhesive prior to TRA.
 - b) Strip-in all vertical and horizontal joints and ends with 3-course of elastomeric asphalt mastic and reinforcing mesh.
- 9) Install new 24-gauge, pre-finished, metal skirt flashing on interior of parapet walls.
 - a) Metal skirt shall extend up behind existing coping fascia a minimum of 3-inches and secured with grommeted screws.
 - b) Metal skirt shall extend over base flashing bar termination a minimum of 4-inches.
 - c) Metal skirt shall require horizontal stiffening ribs every 8-inches on-center.
 - d) Install matching outside and inside corners.
- 10) Install 22-gauge, pre-finished, gutters and downspouts along the north perimeter.
 - a) Remove and replace any metal coverings below gutter edge prior to installing new gutters.
 - b) Cover all wood fascia below gutters with matching metal that wraps 100% of exposed wood and terminates onto lower brick wall.

- c) Install new concrete splash blocks under all downspouts.
- 11) Install new 24-gauge, pre-finished, gravel stop metal edge along north perimeter.
 - a) Strip-in with 2-ply of trilaminate base sheet adhered with elastomeric adhesive.
 - b) New exterior metal fascia shall extend down over gutter fascia a minimum of 3-inches.
- 12) Install new 22-gauge gravel dam along north perimeter. Dam must be approximately 8 to 12-inches off perimeter edge.
 - a) Coat membrane between gravel dams and drains with two coats of aluminum reflective coating.
- 13) At RTU's with neoprene flashing; cover neoprene flashing with new 24-gauge metal detail.
- 14) Install cold process modified asphalt flood coat and Kunshek gravel surface.
- 15) Install two coats of aluminum reflective coating to all base flashing, plumbing pipes, and rusted equipment.
- 16) Replace all existing wood blocking supports with new treated wood blocking and protection treads.
 - a) Blocking supports shall be spaced every eight foot on-center minimum.

6. **NCO – Building A**

2010 N. 59th Street
K.C., KS 66104

a. Roofs 2 and 3 – Roof Replacement:

- 1) Tear off all roofing and insulation down to concrete decks.
 - a) Remove antenna's, lights, and all support bases as needed to complete the work. Reinstall in same location after work is complete.
- 2) Remove all perimeter and projection flashing and metal terminations.
- 3) Remove and replace the existing roof hatch with a new Bilco roof hatch to match the size of the existing.
 - a) Install new TRA flashing over roof hatch curb prior to installing new hatch.
- 4) Install new wood blocking around the perimeter edges to accommodate new insulation and provide a raised edge detail.
- 5) Install new wood blocking as needed to provide a control joint detail separating Roofs 2 and 3.
 - a) Taper ends of expansion joint to provide a watertight transition into the outside perimeter raised edge detail.
- 6) Prime concrete deck with asphalt primer.
- 7) Adhere trilaminate base sheet over concrete decks with hot Type IV asphalt.
- 8) Adhere 2" polyisocyanurate insulation over base sheet with hot Type IV asphalt.
- 9) Adhere ¼" gypsum coverboard with hot Type IV asphalt.
- 10) Adhere 1-ply of trilaminate base sheet over coverboard with hot Type IV asphalt.
 - a) Extend base sheet over outside edge and down to with 2" of horizontal concrete offset.
- 11) Adhere 3-ply of 33-lb. fiberglass felt in cold modified asphalt adhesive.

- a) Extend base sheet over outside edge and down to with 2” of horizontal concrete offset.
- b) Install 3-cours reinforcement horizontally along the outside vertical face to secure the 3-ply and base sheet edges.
 - i) Tape off horizontal concrete offset to keep asphalt mastic off concrete.
- 12) Adhere TRA base flashing to all perimeters and projection base flashing with cold elastomeric asphalt mastic.
 - a) Adhere trillaminate backer sheet in elastomeric adhesive prior to TRA.
 - b) Strip-in all vertical and horizontal joints and ends with 3-course of elastomeric asphalt mastic and reinforcing mesh.
- 13) Install 24-gauge, pre-finished, metal raised edge detail at all perimeters.
 - a) Outside fascia shall extend down tight against the horizontal concrete offset.
- 14) Install new 24-gauge pre-finished expansion joint cover separating Roofs 2 and 3.
 - a) Provide a watertight transition into the outside perimeter raised edge details.
- 15) Install new 22-gauge gravel dams around all drains. Dams must be outside of sumps.
 - a) Coat membrane between gravel dams and drains with two coats of aluminum reflective coating.
- 16) Install expansion joint details at horizontal joints and vertical edges, where five (5) concrete roof decks connect to Roofs 2 and 3.
 - a) Provide a masonry contractor to remove the existing material over the concrete deck expansion joints, both horizontal and vertical joints. Clean and prime joints. Install new backer rod. Install new polyurethane sealant and tool.
 - b) Install a new 24-gauge expansion joint hook receiver cleat approximately 10” away from the existing joint and Roofs 2 and 3. Set cleats in double sided butyl tape and anchor into concrete decks. Install 24-gauge expansion joint cover to clip into hook receiver cleat, slope upward towards roof edge, and turn 90-degrees up outside perimeter edge of roof. Upward leg shall extend behind new raised edge fascia a minimum of four inches and attach to wood blocking. Provide matching metal end closures. Install new wood blocking as needed to accommodate new expansion joint detail and connecting raised edge detail. Install rubber flashing boot over plumbing pipe and onto new metal expansion joint cover and adhere with appropriate adhesive.
- 17) Over new roof membrane, install cold modified asphalt flood coat and Kunshek gravel surface.
- 18) Install two coats of aluminum reflective coating to all base flashing, plumbing pipes, drain sumps, rusted equipment, and drain strainers.

7. **Sumner Academy**

1610 N. 8th Street
K.C., KS 66101

a. Roofs 17, 17A, 17B, 18, 20, 21, and 26 – Roof Restoration:

- 1) Wet vacuum granular surface clean of all dirt, dust, and debris.
- 2) Remove all wet areas as marked on the roof membrane.

- a) Mechanically fasten polyisocyanurate insulation over metal deck or adhere over concrete deck with low rise foam insulation adhesive.
 - i) Insulation shall fill void where roofing and insulation has been removed and be within 1/4" of being flush with existing roof.
 - ii) Fasteners shall not extend below the bottom flutes of the metal deck.
 - b) Adhere 1/4" gypsum coverboard with low-rise foam insulation adhesive. Top of new coverboard will be flush with existing roof.
 - c) Fully adhere 3-ply of trilaminate ply sheets with solvent-free cold asphalt adhesive.
- 3) Spud away any embedded granules and loose mastic, and reinforce all vent stacks, pitch pans, and plumbing pipes with 5-course repair of asphalt mastic and reinforcing mesh.
 - 4) Shave-off all blisters and ridges and repair with a minimum of 3-ply of trilaminate base sheet adhered in cold solvent-free asphalt adhesive.
 - 5) Replace all sealant at perimeters and projection flashing details. Remove existing sealant, clean and prime metal, reinstall new polyurethane sealant and tool.
 - 6) Resecure and/or replace any loose or missing metal details.
 - 7) Fill all pitch pans and install pitch pan covers where missing.
 - 8) Roofing material manufacturer shall inspect and approve the cleanliness of the roof surface prior to installing new flood coat and aggregate.
 - a) Contractor shall not proceed with flood coat until approved.
 - 9) Remove and replace wrinkled wall flashing as designated during the pre-bid roof walk.
 - a) Replace with matching material.
 - 10) Reinforce all flashing laps and corners with a 3-course reinforcement of modified urethane base coat and polyester.
 - a) Apply base coat to all vertical and horizontal laps and corners at 2 to 3 gal/100 sq. ft. Weathered surfaces may require additional base coat material.
 - b) Embed the polyester reinforcement and extend down past the bottom edge of the cant or roof transition. Brush for proper adhesion and removal of all voids.
 - c) Apply a second coat of base coat, at 2 gal/100 sq. ft., over the reinforcement and a minimum of 2" beyond edges in each direction, feather out edges.
 - 11) Coat all flashing with a two-coat bio-based polyurethane elastomeric coating system.
 - a) Apply base coat at a rate of 2 to 3 gal/100 sq. ft.
 - b) Allow base coat to cure (min. 24 hours). Apply finish coat at a rate of 2 gals/100 sq. ft. minimum. If base coat has been down longer than 72 hours prior to the application of finish coat, prime the base coat with specified primer.
 - 12) Install new 22-gauge gravel dams around all drains. Hold back from edge of sump.
 - a) Coat membrane between gravel dams and gutters with two coats of aluminum reflective coating.
 - 13) On Roof 26, install two new 24-gauge metal covers over obsolete curbs covered with existing granular surfaced membrane.
 - 14) Install cold process adhesive flood coat and Kunshek gravel.

- a) On Roof 26 at west and east valley, minimum 4' wide, install a base layer of flood coat material at 3-4 gallons per square minimum, and lightly cover with gravel prior to installing final flood coat at 7-gallons per square minimum.
- 15) Replace all wood blocking supports with new treated wood blocking with protection treads separating the wood from the gravel surface.
- 16) Paint all soil stacks, gas lines, rusted equipment and all counterflashing metal terminations with two coats of polyurethane elastomeric finish coating system.
- b. Roofs 13 and 29 – Roof Replacement:
 - 1) Tear off all roofing and insulation down to concrete decks.
 - 2) Remove all perimeter and projection flashing and metal terminations.
 - 3) Remove and replace the existing roof hatch on Roof 13 with a new Bilco roof hatch to match the size of the existing.
 - a) Install new TRA flashing over roof hatch curb prior to installing new hatch.
 - 4) On Roof 29, install new wood blocking around the perimeter edges to accommodate new insulation and provide a raised edge detail.
 - 5) Prime concrete deck with asphalt primer.
 - 6) Adhere trilaminate base sheet over concrete decks with hot Type IV asphalt.
 - 7) Adhere 2" polyisocyanurate insulation over base sheet with hot Type IV asphalt.
 - 8) Adhere ¼" gypsum coverboard with hot Type IV asphalt.
 - 9) Adhere 1-ply of trilaminate base sheet over coverboard with hot Type IV asphalt.
 - 10) Adhere 3-ply of 33-lb. fiberglass felt in cold modified asphalt adhesive.
 - 11) Adhere TRA base flashing to all perimeters and projection base flashing with cold elastomeric asphalt mastic.
 - a) Adhere trilaminate backer sheet in elastomeric adhesive prior to TRA.
 - b) Strip-in all vertical and horizontal joints and ends with 3-course of elastomeric asphalt mastic and reinforcing mesh.
 - 12) On Roof 29, install 24-gauge, pre-finished, metal raised edge detail at all perimeters.
 - a) Outside fascia shall extend down past existing bottom edge a minimum of one inch.
 - 13) On Roof 29, install new 24-gauge stainless steel scupper sleeves and strip-in with two plies of trilaminate base sheet set in elastomeric adhesive.
 - a) Install 40" x 40" sump around all scuppers.
 - b) Install 24-gauge pre-finished scupper heads and downspouts.
 - c) Install new concrete splash blocks and protection treads under each downspout.
 - 14) Install new 22-gauge gravel dams around all drains. Dams must be outside of sumps.
 - a) Coat membrane between gravel dams and drains with two coats of aluminum reflective coating.
 - 15) Over new roof membrane, install cold modified asphalt flood coat and Kunshek gravel surface.
 - 16) Install two coats of aluminum reflective coating to all base flashing, plumbing pipes, drain sumps, rusted equipment, and drain strainers.

8. Washington High School

7340 Leavenworth Road

K.C., KS 66109

- a. Roofs 24, 27, 28, and 29 – Roof Replacement:
- 1) Tear off all roofing and insulation down to concrete and metal decks.
 - a) Remove and replace all existing sheet metal details and flashing.
 - b) Remove all scupper sleeves, scupper heads, and downspouts.
 - 2) Add wood blocking around outside perimeter as needed to accommodate new tapered insulation.
 - a) New wood shall accommodate new raised edge detail.
 - 3) Provide masonry contractor to remove existing sealant and install new urethane sealant in vertical wall joint in northeast corner of Roof 24.
 - 4) Prime concrete deck with an asphalt primer.
 - 5) Adhere 1-ply of trilaminate felt over primed concrete deck with hot Type IV asphalt.
 - 6) Sweep and clean metal deck and flutes clean of all dirt, dust, and debris.
 - 7) Adhere tapered polyisocyanurate insulation over base sheet with hot Type IV asphalt, and mechanically fasten base layer over metal deck with one fastener every two square feet.
 - a) Slope 1/8" per foot on all roofs
 - b) Starting height: 2" on Roof 28 and 2.5" on Roofs 24, 27, and 29.
 - 8) Adhere 1/4" gypsum coverboard with hot modified asphalt.
 - 9) Adhere 1-ply of trilaminate base sheet over insulation with hot Type IV asphalt.
 - 10) Adhere 3-ply of 33-lbs fiberglass ply sheets in cold modified asphalt adhesive.
 - 11) Adhere TRA base flashing to all perimeters and projection base flashing with cold elastomeric asphalt mastic.
 - a) Strip-in all vertical and horizontal joints and ends with 3-course of elastomeric asphalt mastic and reinforcing mesh.
 - 12) Install new copper skirt metal at all brick walls with copper receivers.
 - a) Install matching copper end closures and corners.
 - 13) Install new 24-gauge, pre-finished skirt metal at all brick walls with metal receivers.
 - a) Install matching pre-finished end closures and corners.
 - 14) Install new 24-gauge, pre-finished metal, raised edge detail along all outside perimeters.
 - a) New exterior fascia shall extend down outside wall a minimum of two inches below existing.
 - 15) Install new 24-gauge stainless steel scupper sleeves and strip-in with two plies of trilaminate base sheet set in elastomeric adhesive.
 - a) Install 40" x 40" sump around all scuppers.
 - b) Install 24-gauge pre-finished scupper heads and downspouts.
 - c) Install new concrete splash blocks and protection treads under each downspout.
 - 16) Install new 22-gauge gravel dams around all drains and scuppers. Dams must be outside of sumps.
 - a) Coat membrane between gravel dams and drains with two coats of aluminum reflective coating.

- 17) Over new roof membrane, install cold modified asphalt flood coat and Kunshek gravel surface.
- 18) Install two coats of aluminum reflective coating to all base flashing, plumbing pipes, drain sumps, rusted equipment, and drain strainers.

9. Wyandotte High

6811 Wavery Ave.
K.C., KS 66104

a. Roofs 16 and 17 – Roof Replacement:

- 1) Prior to the start of any roofing work, contractor shall provide an approved masonry contractor to tuckpoint, repair movement cracks, and seal brick on the brick walls at the south ends of both Roofs 16 and 17.
- 2) Tear off all roofing and insulation down to concrete decks.
 - a) Remove and replace existing surface mount and reglet counterflashing around perimeter walls.
- 3) Replace five (5) drains with new 4" cast iron drain bowls, piping connections, clamping ring, and drain strainers.
- 4) Prime concrete deck with an asphalt primer.
- 5) Adhere 1-ply of trilaminate felt over primed concrete deck with hot Type IV asphalt.
- 6) Adhere 2" polyisocyanurate insulation with hot Type IV asphalt.
- 7) Adhere tapered polyisocyanurate insulation crickets between all drains and between all outside walls and drains in the east and west valley areas with hot asphalt.
 - a) New crickets shall provide a 1/4" slope per foot.
- 8) Adhere 1/4" gypsum coverboard with hot Type IV asphalt.
- 9) Adhere 1-ply of trilaminate base sheet over insulation with hot Type IV asphalt.
- 10) Adhere 1-ply of granular surfaced, fire-rated SBS modified bitumen membrane with hot Type IV asphalt.
 - a) Install MB membrane in valley areas perpendicular to slope and on Roof 16 extend up sloped roof at least 9' or 12'.
 - b) Strap MB membrane over the remaining sloped roof area and overlap onto the lower perpendicular MB sheet a minimum of eight inches. Strapped MB membrane must wrap over ridgeline by at least twelve inches.
 - c) Once the east and west sloped roofs areas are covered with MB install one MB sheet parallel with the ridgeline.
 - i) Cut off the salvage edge prior to installing.
 - d) Install matching-colored granules anywhere bleed out occurs along the salvage and butt laps.
- 11) Adhere 2-ply base flashing to all perimeters and base flashings with hot Type IV asphalt adhesive.
 - a) 1-ply trilaminate base ply.
 - b) 1-ply granular surfaced cap sheet matching field membrane.
 - c) Install matching-colored granules anywhere bleed out occurs along flashing laps or toe.
- 12) Install new 24-gauge pre-finished surface mount counterflashing at all perimeter brick walls.

- a) Counterflashing shall include double sided butyl tape between the wall and metal transition.
 - i) At parapet walls, butt new counterflashing up under limestone coping overhang to eliminate any exposed brick.

- b. Roof 20 – Roof Replacement – Base Bid:
 - 1) Tear off all roofing and insulation down to concrete decks.
 - a) Remove and replace existing surface mount counterflashing around perimeter walls and curb around large blow-off hatch.
 - b) Remove existing hatch cover at west perimeter and install new hatch cover to properly fit concrete curb and provide safe entrance and exit.
 - 2) Replace two (2) drains with new 4” cast iron drain bowls, piping connections, clamping rings, and drain strainers.
 - 3) Prime concrete deck with an asphalt primer.
 - 4) Adhere 1-ply of trilaminate felt over primed concrete deck with hot Type IV asphalt.
 - 5) Adhere 2” polyisocyanurate insulation with hot modified asphalt.
 - 6) Adhere tapered polyisocyanurate insulation crickets between east drain and south wall with hot asphalt.
 - a) New crickets shall provide a ½” slope per foot.
 - 7) Adhere 1/4” gypsum coverboard with hot modified asphalt.
 - 8) Adhere 1-ply of trilaminate base sheet over insulation with hot modified asphalt.
 - 9) Adhere 3-ply of 33-lbs fiberglass ply sheets in cold modified asphalt adhesive.
 - 10) Adhere TRA base flashing to all perimeters and projection base flashing with cold elastomeric asphalt mastic.
 - a) Strip-in all vertical and horizontal joints and ends with 3-course of elastomeric asphalt mastic and reinforcing mesh.
 - 11) Install new 24-gauge pre-finished surface mount counterflashing at all outside brick and stucco walls.
 - a) Counterflashing shall include double sided butyl tape between the wall and metal transition.
 - 12) Install new 24-gauge pre-finished skirt counterflashing around curb for large blow-off hatch.
 - 13) Install new 22-gauge gravel dams around all drains. Dams must be outside of sumps.
 - a) Coat membrane between gravel dams and drains with two coats of aluminum reflective coating.
 - 14) Over new roof membrane, install cold modified asphalt flood coat and Kunshek gravel surface.
 - 15) Install two coats of aluminum reflective coating to all base flashing, plumbing pipes, drain sumps, rusted equipment, and drain strainers.

1.4 TYPE OF CONTRACT

- A. Project will be constructed under a single prime contract.

1.5 USE OF PREMISES

- A. Use of Site: Limit use of premises to work in areas indicated. Do not disturb portions of project site beyond areas in which the Work is indicated.
 - 1. Driveways and Entrances: Keep driveways, loading areas, and entrances serving premises clear and available to Owner, Owner's employees, and emergency vehicles at all times. Do not use these areas for parking or storage of materials.
 - a. Schedule deliveries to minimize space and time requirements for storage of materials and equipment on-site.
- B. Use of Existing Building: Maintain existing building in a watertight condition throughout construction period. Repair damage caused by construction operations. Protect building and its occupants during construction period.
- C. Security: Comply with Owner's requirements related to security.
- D. Safety: Comply with all OSHA regulations and guidelines that apply to project.
- E. No smoking on Owner's property.
- F. No changing into or from work clothes on site.
- G. Use of adjacent roofs not related to the project is prohibited without written approval from Owner.

1.6 OWNER'S OCCUPANCY REQUIREMENTS

- A. Partial Owner Occupancy: Owner will occupy the premises during entire construction period, with the exception of areas under construction. Cooperate with Owner during construction operations to minimize conflicts and facilitate Owner usage. Perform the Work so as not to interfere with Owner's operations. Maintain existing exits, unless otherwise indicated.
 - 1. Maintain access to existing walkways, corridors, and other adjacent occupied or used facilities. Do not close or obstruct walkways, corridors, or other occupied or used facilities without written permission from Owner and authorities having jurisdiction.
 - 2. Provide not less than 72 hours' notice to Owner of activities that will affect Owner's operations.
- B. Owner Occupancy of Completed Areas of Construction: Owner reserves the right to occupy and to place and install equipment in completed areas of building, before Substantial Completion, provided such occupancy does not interfere with completion of the Work. Such placement of equipment and partial occupancy shall not constitute acceptance of the total Work.
 - 1. Before partial Owner occupancy, mechanical and electrical systems shall be fully operational, and required tests and inspections shall be successfully completed. On occupancy, Owner will operate and maintain mechanical and electrical systems serving occupied portions of building.

1.7 WORK RESTRICTIONS

- A. On-Site Work Hours: Work shall be generally performed inside the existing building during normal business working hours of 7:00 a.m. to 5:00 p.m., Monday through Friday, except otherwise indicated.
 - 1. Weekend Hours: As approved by Owner.
 - 2. Early Morning Hours: As approved by Owner.
 - 3. Hours for Utility Shutdowns: Coordinated with and approved by Owner.
- B. Existing Utility Interruptions: Do not interrupt utilities serving facilities occupied by Owner or others unless permitted under the following conditions and then only after arranging to provide temporary utility services according to requirements indicated:
 - 1. Notify Owner not less than two days in advance of proposed utility interruptions.
 - 2. Do not proceed with utility interruptions without Owner's written permission.

1.8 SPECIFICATION FORMATS AND CONVENTIONS

- A. Specification Format: The Specifications are organized into Divisions and Sections using the 16-division format and CSI/CSC's "Master Format" numbering system.
- B. Specification Content: The Specifications use certain conventions for the style of language and the intended meaning of certain terms, words, and phrases when used in particular situations. These conventions are as follows:
 - 1. Abbreviated Language: Language used in the Specifications and other Contract Documents is abbreviated. Words and meanings shall be interpreted as appropriate. Words implied, but not stated, shall be inferred, as the sense requires. Singular words shall be interpreted as plural and plural words shall be interpreted as singular where applicable as the context of the Contract Documents indicates.
 - 2. Imperative mood and streamlined language are generally used in the Specifications. Requirements expressed in the imperative mood are to be performed by Contractor. Occasionally, the indicative or subjunctive mood may be used in the Section Text for clarity to describe responsibilities that must be fulfilled indirectly by Contractor or by others when so noted.
 - a. The words "shall," "shall be," or "shall comply with," depending on the context, are implied where a colon (:) is used within a sentence or phrase.

PART 2 - PRODUCTS (Not Used)

PART 3 - EXECUTION (Not Used)

END OF SECTION 01100

SECTION 01270 - UNIT PRICES

PART 1 - GENERAL

1.1 RELATED DOCUMENTS

- A. Drawings and general provisions of the Contract, including General and Supplementary Conditions and other Division 1 Specification Sections, apply to this Section.

1.2 SUMMARY

- A. This Section includes administrative and procedural requirements for unit prices.

1.3 DEFINITIONS

- A. Unit price is an amount proposed by bidders, stated on the Bid Form, as a price per unit of measurement for materials or services added to or deducted from the Contract Sum by appropriate modification, if estimated quantities of Work required by the Contract Documents are increased or decreased.

1.4 PROCEDURES

- A. Unit prices include all necessary material, plus cost for delivery, installation, insurance, applicable taxes, overhead, and profit.
- B. Measurement and Payment: Refer to individual Specification Sections for work that requires establishment of unit prices. Methods of measurement and payment for unit prices are specified in those Sections.
- C. Owner reserves the right to reject Contractor's measurement of work-in-place that involves use of established unit prices and to have this work measured, at Owner's expense, by an independent surveyor acceptable to Contractor.
- D. List of Unit Prices: A list of unit prices is included in Part 3. Specification Sections referenced in the schedule contain requirements for materials described under each unit price.

PART 2 - PRODUCTS (Not Used)

PART 3 - EXECUTION

3.1 LIST OF UNIT PRICES

- A. Wood blocking replacement:

1. Description: Provide new wood blocking according to Division 6 Section "Miscellaneous Carpentry."
- B. Drain Bowl Replacement:
 1. Description: Remove existing drain bowl and replace with new five-inch cast iron drain bowl and connections according to local building codes.
- C. Drain Clamping Ring Replacement:
 1. Description: Remove existing drain clamping ring and replace with new cast iron drain clamping ring per local building codes.
- D. Metal Deck repair:
 1. Description: Remove existing deck material and replace according to Division 5 – 05310 Steel Deck.
- E. Metal Deck replacement:
 1. Description: Remove existing deck material and replace according to Division 5 – 05310 Steel Deck.
- F. Concrete & Gypsum Deck replacement:
 1. Description: Remove damaged decking and repair areas of all dirt, dust, and debris. Skim repair areas with quick-set gypsum per roofing material manufacturer's recommendations.
- G. Plywood Replacement:
 1. Description: Remove damaged plywood and replace with new 5/8" plywood according to Division 6 Section "Miscellaneous Carpentry."
- H. Tectum Deck panel replacement:
 1. Description: Remove existing deck panel (3" x 3' x 5') and replace according to Division 3 – 03511 Tectum Deck.
- I. Flat-stock metal plates:
 1. Description: Install 18-gauge flat-stock metal over damaged deck and or holes and voids in decking. Secure new flat-stock to deck with approved fasteners.

END OF SECTION 01270

SECTION 01290 - PAYMENT PROCEDURES

PART 1 - GENERAL

1.1 RELATED DOCUMENTS

- A. Drawings and general provisions of the Contract, including General and Supplementary Conditions and other Division 1 Specification Sections, apply to this Section.

1.2 SUMMARY

- A. This Section specifies administrative and procedural requirements necessary to prepare and process Applications for Payment.
- B. Related Sections include the following:
 - 1. Division 1 Section "Allowances" for procedural requirements governing handling and processing of allowances.
 - 2. Division 1 Section "Contract Modification Procedures" for administrative procedures for handling changes to the Contract.
 - 3. Division 1 Section "Unit Prices" for administrative requirements governing use of unit prices.

1.3 DEFINITIONS

- A. Schedule of Values: A statement furnished by Contractor allocating portions of the Contract Sum to various portions of the Work and used as the basis for reviewing Contractor's Applications for Payment.

1.4 SCHEDULE OF VALUES

- A. Coordination: Coordinate preparation of the Schedule of Values with preparation of Contractor's Construction Schedule.
 - 1. Correlate line items in the Schedule of Values with other required administrative forms and schedules, including the following:
 - a. Application for Payment forms with Continuation Sheets.
 - b. Submittals Schedule.
 - c. Contractor's Construction Schedule.
 - 2. Submit the Schedule of Values to District at earliest possible date but no later than seven days before the date scheduled for submittal of initial Applications for Payment.
 - 3. Sub schedules: Where the Work is separated into phases requiring separately phased payments, provide sub schedules showing values correlated with each phase of payment.

- B. Format and Content: Use the Project Manual table of contents as a guide to establish line items for the Schedule of Values. Provide at least one line-item for each Specification Section.
1. Identification: Include the following Project identification on the Schedule of Values:
 - a. Project name and location.
 - b. Contractor's name and address.
 - c. Date of submittal.
 2. Arrange the Schedule of Values in tabular form with separate columns to indicate the following for each item listed:
 - a. Related Specification Section or Division.
 - b. Description of the Work.
 - c. Name of subcontractor.
 - d. Name of manufacturer or fabricator.
 - e. Name of supplier.
 - f. Change Orders (numbers) that affect value.
 - g. Dollar value.
 - 1) Percentage of the Contract Sum to nearest one-hundredth percent, adjusted to total 100 percent.
 3. Provide a breakdown of the Contract Sum in enough detail to facilitate continued evaluation of Applications for Payment and progress reports. Coordinate with the Project Manual table of contents. Provide several line items for principal subcontract amounts, where appropriate.
 4. Round amounts to nearest whole dollar; total shall equal the Contract Sum.
 5. Provide a separate line item in the Schedule of Values for each part of the Work where Applications for Payment may include materials or equipment purchased or fabricated and stored, but not yet installed.
 - a. Differentiate between items stored on-site and items stored off-site. If specified, include evidence of insurance or bonded warehousing.
 6. Provide separate line items in the Schedule of Values for initial cost of materials, for each subsequent stage of completion, and for total installed value of that part of the Work.
 7. Allowances: Provide a separate line item in the Schedule of Values for each allowance. Show line-item value of unit-cost allowances, as a product of the unit cost, multiplied by measured quantity. Use information indicated in the Contract Documents to determine quantities.
 8. Each item in the Schedule of Values and Applications for Payment shall be complete. Include total cost and proportionate share of general overhead and profit for each item.
 - a. Temporary facilities and other major cost items that are not direct cost of actual work-in-place may be shown either as separate line items in the Schedule of Values or distributed as general overhead expense, at Contractor's option.
 9. Schedule Updating: Update and resubmit the Schedule of Values before the next Applications for Payment when Change Orders or Construction Change Directives result in a change in the Contract Sum.

1.5 APPLICATIONS FOR PAYMENT

- A. Each Application for Payment shall be consistent with previous applications and payments as certified by District and paid for by Owner.
 - 1. Initial Application for Payment, Application for Payment at time of Substantial Completion, and final Application for Payment involve additional requirements.
- B. Payment Application Times: The date for each progress payment is indicated in the Agreement between Owner and Contractor. The period of construction Work covered by each Application for Payment is the period indicated in the Agreement.
- C. Payment Application Times: Progress payments shall be submitted to Owner by the 1st day of the month. The period covered by each Application for Payment is one month, ending on the last day of the month.
- D. Payment Application Forms: Use AIA Document G702 and AIA Document G703 Continuation Sheets as form for Applications for Payment.
- E. Payment Application Forms: Use forms provided by Owner for Applications for Payment. Sample copies are included at end of this Section.
- F. Application Preparation: Complete every entry on form. Notarize and execute by a person authorized to sign legal documents on behalf of Contractor. District will return incomplete applications without action.
 - 1. Entries shall match data on the Schedule of Values and Contractor's Construction Schedule. Use updated schedules if revisions were made.
 - 2. Include amounts of Change Orders and Construction Change Directives issued before last day of construction period covered by application.
- G. Transmittal: Submit 3 signed and notarized original copies of each Application for Payment to District by a method ensuring receipt within 24 hours. One copy shall include waivers of lien and similar attachments if required.
 - 1. Transmit each copy with a transmittal form listing attachments and recording appropriate information about application.
- H. Waivers of Mechanic's Lien: With each Application for Payment, submit waivers of mechanic's lien from every entity who is lawfully entitled to file a mechanic's lien arising out of the Contract and related to the Work covered by the payment.
 - 1. Submit partial waivers on each item for amount requested in previous application, after deduction for retainage, on each item.
 - 2. When an application shows completion of an item, submit final or full waivers.
 - 3. Owner reserves the right to designate which entities involved in the Work must submit waivers.
 - 4. Waiver Forms: Submit waivers of lien on forms, executed in a manner acceptable to Owner.

- I. Waivers of Mechanic's Lien: With each Application for Payment, submit waivers of mechanic's liens from subcontractors, sub-subcontractors, and suppliers for construction period covered by the previous application.
 - 1. Submit partial waivers on each item for amount requested in previous application, after deduction for retainage, on each item.
 - 2. When an application shows completion of an item, submit final or full waivers.
 - 3. Owner reserves the right to designate which entities involved in the Work must submit waivers.
 - 4. Submit final Application for Payment with or preceded by final waivers from every entity involved with performance of the Work covered by the application who is lawfully entitled to a lien.
 - 5. Waiver Forms: Submit waivers of lien on forms, executed in a manner acceptable to Owner.

- J. Initial Application for Payment: Administrative actions and submittals that must precede or coincide with submittal of first Application for Payment include the following:
 - 1. List of subcontractors.
 - 2. Schedule of Values.
 - 3. Contractor's Construction Schedule (preliminary if not final).
 - 4. Products list.
 - 5. Schedule of unit prices.
 - 6. Submittals Schedule (preliminary if not final).
 - 7. List of Contractor's staff assignments.
 - 8. List of Contractor's principal consultants.
 - 9. Copies of building permits.
 - 10. Copies of authorizations and licenses from authorities having jurisdiction for performance of the Work.
 - 11. Initial progress report.
 - 12. Report of preconstruction conference.
 - 13. Certificates of insurance and insurance policies.
 - 14. Performance and payment bonds.
 - 15. Data needed to acquire Owner's insurance.
 - 16. Initial settlement survey and damage report if required.

- K. Application for Payment at Substantial Completion: After issuing the Certificate of Substantial Completion, submit an Application for Payment showing 100 percent completion for portion of the Work claimed as substantially complete.
 - 1. Include documentation supporting claim that the Work is substantially complete and a statement showing an accounting of changes to the Contract Sum.
 - 2. This application shall reflect Certificates of Partial Substantial Completion issued previously for Owner occupancy of designated portions of the Work.

- L. Final Payment Application: Submit final Application for Payment with releases and supporting documentation not previously submitted and accepted, including, but not limited, to the following:
 - 1. Evidence of completion of Project closeout requirements.

2. Insurance certificates for products and completed operations where required and proof that taxes, fees, and similar obligations were paid.
3. Updated final statement, accounting for final changes to the Contract Sum.
4. AIA Document G706, "Contractor's Affidavit of Payment of Debts and Claims."
5. AIA Document G706A, "Contractor's Affidavit of Release of Liens."
6. AIA Document G707, "Consent of Surety to Final Payment."
7. Evidence that claims have been settled.
8. Final meter readings for utilities, a measured record of stored fuel, and similar data as of date of Substantial Completion or when Owner took possession of and assumed responsibility for corresponding elements of the Work.
9. Final, liquidated damages settlement statement.

PART 2 - PRODUCTS (Not Used)

PART 3 - EXECUTION (Not Used)

END OF SECTION 01290

SECTION 01330 - SUBMITTAL PROCEDURES

PART 1 - GENERAL

1.1 RELATED DOCUMENTS

- A. Drawings and general provisions of the Contract, including General and Supplementary Conditions and other Division 1 Specification Sections, apply to this Section.

1.2 SUMMARY

- A. This Section includes administrative and procedural requirements for submitting Shop Drawings, Product Data, Samples, and other submittals.

1.3 DEFINITIONS

- A. Action Submittals: Written and graphic information that requires Owner's responsive action.
- B. Informational Submittals: Written information that does not require Owner's responsive action. Submittals may be rejected for not complying with requirements.

1.4 SUBMITTAL PROCEDURES

- A. General: Electronic copies of CAD Drawings of the Contract Drawings will be provided by Owner for Contractor's use in preparing submittals.
- B. Coordination: Coordinate preparation and processing of submittals with performance of construction activities. Submit complete submittal package.
- C. Processing Time: Allow enough time for submittal review, including time for resubmittals, as follows. Time for review shall commence on Owner's receipt of submittal.
 - 1. No extension of the Contract Time will be authorized because of failure to transmit submittals enough in advance of the Work to permit processing, including resubmittals.
 - 2. Initial Review: Allow 10 days for initial review of each submittal. Allow additional time if coordination with subsequent submittals is required. Owner will advise Contractor when a submittal being processed must be delayed for coordination.
 - 3. Resubmittal Review: Allow 10 days for review of each resubmittal.
 - 4. Concurrent Consultant Review: Where the Contract Documents indicate that submittals may be transmitted simultaneously to Owner and to Owner's consultants, allow 10 days for review of each submittal. Submittal will be returned to Owner before being returned to Contractor.
- D. Identification: Place a permanent label or title block on each submittal for identification.
 - 1. Indicate name of firm or entity that prepared each submittal on label or title block.

2. Provide a space approximately 6 by 8 inches (150 by 200 mm) on label or beside title block to record Contractor's review and approval markings and action taken by Owner.
 3. Include the following information on label for processing and recording action taken:
 - a. Project name.
 - b. Date.
 - c. Name and address of Owner.
 - d. Name and address of Contractor.
 - e. Name and address of subcontractor.
 - f. Name and address of supplier.
 - g. Name of manufacturer.
 - h. Submittal number or other unique identifier, including revision identifier.
 - 1) Submittal number shall use Specification Section number followed by a decimal point and then a sequential number (e.g., 06100.01). Resubmittals shall include an alphabetic suffix after another decimal point (e.g., 06100.01.A).
 - i. Number and title of appropriate Specification Section.
 - j. Drawing number and detail references, as appropriate.
 - k. Location(s) where product is to be installed, as appropriate.
 - l. Other necessary identification.
- E. Deviations: Highlight, encircle, or otherwise specifically identify deviations from the Contract Documents on submittals.
- F. Additional Copies: Unless additional copies are required for final submittal, and unless Owner observes noncompliance with provisions in the Contract Documents, initial submittal may serve as final submittal.
1. Submit one copy of submittal to concurrent reviewer in addition to specified number of copies to Owner.
 2. Additional copies submitted for maintenance manuals will not be marked with action taken and will be returned.
- G. Transmittal: Package each submittal individually and appropriately for transmittal and handling. Transmit each submittal using a transmittal form. Owner will discard submittals received from sources other than Contractor.
1. Transmittal Form: Use AIA Document G810, CSI Form 12.1A, or similar form acceptable to Owner.
 2. On an attached separate sheet, prepared on Contractor's letterhead, record relevant information, requests for data, revisions other than those requested by Owner on previous submittals, and deviations from requirements in the Contract Documents, including minor variations and limitations. Include same label information as related submittal.
- H. Resubmittals: Make resubmittals in same form and number of copies as initial submittal.
1. Note date and content of previous submittal.
 2. Note date and content of revision in label or title block and clearly indicate extent of revision.

3. Resubmit submittals until they are marked "Approved" or "Approved as Noted."
- I. Distribution: Furnish copies of final submittals to manufacturers, subcontractors, suppliers, fabricators, installers, authorities having jurisdiction, and others as necessary for performance of construction activities. Show distribution on transmittal forms.
- J. Use for Construction: Use only final submittals with mark indicating ""Approved" or "Approved as Noted."

PART 2 - PRODUCTS

2.1 ACTION SUBMITTALS

- A. General: Prepare and submit Action Submittals required by individual Specification Sections.
- B. Product Data: Collect information into a single submittal for each element of construction and type of product or equipment.
 1. If information must be specially prepared for submittal because standard printed data are not suitable for use, submit as Shop Drawings, not as Product Data.
 2. Mark each copy of each submittal to show which products and options are applicable.
 3. Include the following information, as applicable:
 - a. Manufacturer's written recommendations.
 - b. Manufacturer's product specifications.
 - c. Manufacturer's installation instructions.
 - d. Standard color charts.
 - e. Standard product operation and maintenance manuals.
 - f. Compliance with specified referenced standards.
 - g. Testing by recognized testing agency.
 - h. Notation of coordination requirements.
 4. Submit Product Data before or concurrent with Samples.
 5. Number of Copies: Submit three copies of Product Data, unless otherwise indicated. Owner will return one copy. Mark up and retain one returned copy as a Project Record Document.
- C. Shop Drawings: Prepare Project-specific information, drawn accurately to scale. Do not base Shop Drawings on reproductions of the Contract Documents or standard printed data.
 1. Preparation: Fully illustrate requirements in the Contract Documents. Include the following information, as applicable:
 - a. Dimensions.
 - b. Identification of products.
 - c. Fabrication and installation drawings.
 - d. Schedules.
 - e. Compliance with specified standards.
 - f. Notation of coordination requirements.

- g. Notation of dimensions established by field measurement.
 - h. Relationship to adjoining construction clearly indicated.
 - i. Seal and signature of professional engineer if specified.
 2. Sheet Size: Except for templates, patterns, and similar full-size drawings, submit Shop Drawings on sheets at least 8-1/2 by 11 inches (215 by 280 mm) but no larger than 30 by 40 inches (750 by 1000 mm).
 3. Number of Copies: Submit two opaque (bond) copies of each submittal. Owner will return one copy.
- D. Samples: Submit Samples for review of kind, color, pattern, and texture for a check of these characteristics with other elements and for a comparison of these characteristics between submittal and actual component as delivered and installed.
 1. Transmit Samples that contain multiple, related components such as accessories together in one submittal package.
 2. Identification: Attach label on unexposed side of Samples that includes the following:
 - a. Generic description of Sample.
 - b. Product name and name of manufacturer.
 - c. Sample source.
 - d. Number and title of appropriate Specification Section.
 3. Disposition: Maintain sets of approved Samples at Project site, available for quality-control comparisons throughout the course of construction activity. Sample sets may be used to determine final acceptance of construction associated with each set.
 - a. Samples not incorporated into the Work, or otherwise designated as Owner's property, are the property of Contractor.
 4. Samples for Initial Selection: Submit manufacturer's color charts consisting of units or sections of units showing the full range of colors, textures, and patterns available.
 - a. Number of Samples: Submit one full set(s) of available choices where color, pattern, texture, or similar characteristics are required to be selected from manufacturer's product line. Owner will return submittal with options selected.
- E. Product Schedule or List: As required in individual Specification Sections, prepare a written summary indicating types of products required for the Work and their intended location. Include the following information in tabular form:
 1. Type of product. Include unique identifier for each product.
 2. Location.
 3. Number of Copies: Submit three copies of product schedule or list, unless otherwise indicated. Owner will return one copy.
 - a. Mark up and retain one returned copy as a Project Record Document.
- F. Application for Payment: Comply with requirements specified in Division 1 Section "Payment Procedures."

- G. Schedule of Values: Comply with requirements specified in Division 1 Section "Payment Procedures."

2.2 INFORMATIONAL SUBMITTALS

- A. General: Prepare and submit Informational Submittals required by other Specification Sections.
 - 1. Number of Copies: Submit three copies of each submittal, unless otherwise indicated. Owner will not return copies.
 - 2. Certificates and Certifications: Provide a notarized statement that includes signature of entity responsible for preparing certification. Certificates and certifications shall be signed by an officer or other individual authorized to sign documents on behalf of that entity.
 - 3. Test and Inspection Reports: Comply with requirements specified in Division 1 Section "Quality Requirements."
- B. Coordination Drawings: Comply with requirements specified in Division 1 Section "Project Management and Coordination."
- C. Qualification Data: Prepare written information that demonstrates capabilities and experience of firm or person. Include lists of completed projects with project names and addresses, names and addresses of Owners and owners, and other information specified.
- D. Welding Certificates: Prepare written certification that welding procedures and personnel comply with requirements in the Contract Documents. Submit record of Welding Procedure Specification (WPS) and Procedure Qualification Record (PQR) on AWS forms. Include names of firms and personnel certified.
- E. Installer Certificates: Prepare written statements on manufacturer's letterhead certifying that Installer complies with requirements in the Contract Documents and, where required, is authorized by manufacturer for this specific Project.
- F. Manufacturer Certificates: Prepare written statements on manufacturer's letterhead certifying that manufacturer complies with requirements in the Contract Documents. Include evidence of manufacturing experience where required.
- G. Product Certificates: Prepare written statements on manufacturer's letterhead certifying that product complies with requirements in the Contract Documents.
- H. Material Certificates: Prepare written statements on manufacturer's letterhead certifying that material complies with requirements in the Contract Documents.
- I. Material Test Reports: Prepare reports written by a qualified testing agency, on testing agency's standard form, indicating and interpreting test results of material for compliance with requirements in the Contract Documents.
- J. Product Test Reports: Prepare written reports indicating current product produced by manufacturer complies with requirements in the Contract Documents. Base reports on evaluation of tests performed by manufacturer and witnessed by a qualified testing agency, or on comprehensive tests performed by a qualified testing agency.

- K. Research/Evaluation Reports: Prepare written evidence, from a model code organization acceptable to authorities having jurisdiction, that product complies with building code in effect for Project. Include the following information:
1. Name of evaluation organization.
 2. Date of evaluation.
 3. Time period when report is in effect.
 4. Product and manufacturers' names.
 5. Description of product.
 6. Test procedures and results.
 7. Limitations of use.
- L. Schedule of Tests and Inspections: Comply with requirements specified in Division 1 Section "Quality Requirements."
- M. Preconstruction Test Reports: Prepare reports written by a qualified testing agency, on testing agency's standard form, indicating and interpreting results of tests performed before installation of product, for compliance with performance requirements in the Contract Documents.
- N. Compatibility Test Reports: Prepare reports written by a qualified testing agency, on testing agency's standard form, indicating and interpreting results of compatibility tests performed before installation of product. Include written recommendations for primers and substrate preparation needed for adhesion.
- O. Field Test Reports: Prepare reports written by a qualified testing agency, on testing agency's standard form, indicating and interpreting results of field tests performed either during installation of product or after product is installed in its final location, for compliance with requirements in the Contract Documents.
- P. Maintenance Data: Prepare written and graphic instructions and procedures for operation and normal maintenance of products and equipment. Comply with requirements specified in Division 1 Section "Operation and Maintenance Data."
- Q. Manufacturer's Instructions: Prepare written or published information that documents manufacturer's recommendations, guidelines, and procedures for installing or operating a product or equipment. Include name of product and name, address, and telephone number of manufacturer. Include the following, as applicable:
1. Preparation of substrates.
 2. Required substrate tolerances.
 3. Sequence of installation or erection.
 4. Required installation tolerances.
 5. Required adjustments.
 6. Recommendations for cleaning and protection.
- R. Manufacturer's Field Reports: Prepare written information documenting factory-authorized service representative's tests and inspections. Include the following, as applicable:
1. Name, address, and telephone number of factory-authorized service representative making report.

2. Statement on condition of substrates and their acceptability for installation of product.
 3. Statement that products at Project site comply with requirements.
 4. Summary of installation procedures being followed, whether they comply with requirements and, if not, what corrective action was taken.
 5. Results of operational and other tests and a statement of whether observed performance complies with requirements.
 6. Statement whether conditions, products, and installation will affect warranty.
 7. Other required items indicated in individual Specification Sections.
- S. Insurance Certificates and Bonds: Prepare written information indicating current status of insurance or bonding coverage. Include name of entity covered by insurance or bond, limits of coverage, amounts of deductibles, if any, and term of the coverage.
- T. Construction Photographs: Comply with requirements specified in Division 1 Section "Photographic Documentation."
- U. Material Safety Data Sheets (MSDSs): Submit information directly to Owner.

PART 3 - EXECUTION

3.1 CONTRACTOR'S REVIEW

- A. Review each submittal and check for coordination with other Work of the Contract and for compliance with the Contract Documents. Note corrections and field dimensions. Mark with approval stamp before submitting to Owner.
- B. Approval Stamp: Stamp each submittal with a uniform, approval stamp. Include Project name and location, submittal number, Specification Section title and number, name of reviewer, date of Contractor's approval, and statement certifying that submittal has been reviewed, checked, and approved for compliance with the Contract Documents.

3.2 OWNER'S ACTION

- A. General: Owner will not review submittals that do not bear Contractor's approval stamp and will return them without action.
- B. Action Submittals: Owner will review each submittal, make marks to indicate corrections or modifications required, and return it. Owner will stamp each submittal with an action stamp and will mark stamp appropriately to indicate action taken.
- C. Informational Submittals: Owner will review each submittal and will not return it, or will return it if it does not comply with requirements. Owner will forward each submittal to appropriate party.
- D. Partial submittals are not acceptable, will be considered nonresponsive, and will be returned without review.

- E. Submittals not required by the Contract Documents may not be reviewed and may be discarded.

END OF SECTION 01330

SECTION 01700 - EXECUTION REQUIREMENTS

PART 1 - GENERAL

1.1 RELATED DOCUMENTS

- A. Drawings and general provisions of the Contract, including General and Supplementary Conditions and other Division 1 Specification Sections, apply to this Section.

1.2 SUMMARY

- A. This Section includes general procedural requirements governing execution of the Work including, but not limited to, the following:
 1. General installation of products.
 2. Progress cleaning.
 3. Protection of installed construction.
 4. Correction of the Work.

PART 2 - PRODUCTS (Not Used)

PART 3 - EXECUTION

3.1 INSTALLATION

- A. General: Locate the Work and components of the Work accurately, in correct alignment and elevation, as indicated.
- B. Comply with manufacturer's written instructions and recommendations for installing products in applications indicated.
- C. Install products at the time and under conditions that will ensure the best possible results. Maintain conditions required for product performance until Substantial Completion.
- D. Conduct construction operations so no part of the Work is subjected to damaging operations or loading in excess of that expected during normal conditions of occupancy.
- E. Tools and Equipment: Do not use tools or equipment that produce harmful noise levels.
- F. Anchors and Fasteners: Provide anchors and fasteners as required to anchor each component securely in place, accurately located and aligned with other portions of the Work.
 1. Allow for building movement, including thermal expansion and contraction.
- G. Hazardous Materials: Use products, cleaners, and installation materials that are not considered hazardous.

3.2 PROGRESS CLEANING

- A. General: Clean Project site and work areas daily. Enforce requirements strictly. Dispose of materials lawfully.
 - 1. Comply with requirements in NFPA 241 for removal of combustible waste materials and debris.
 - 2. Containerize hazardous and unsanitary waste materials separately from other waste. Mark containers appropriately and dispose of legally, according to regulations.
- B. Site: Maintain Project site free of waste materials and debris.
- C. Work Areas: Clean areas where work is in progress to the level of cleanliness necessary for proper execution of the Work.
 - 1. Remove liquid spills promptly.
- D. Concealed Work: Remove debris from concealed work prior to concealing with subsequent construction.
- E. Waste Disposal: Burying or burning waste materials on-site will not be permitted. Washing waste materials down sewers or into waterways will not be permitted.
- F. During handling and installation, clean and protect construction in progress and adjoining materials already in place. Apply protective covering where required to ensure protection from damage or deterioration at Substantial Completion.
- G. Clean and provide maintenance on completed construction as frequently as necessary through the remainder of the construction period.
- H. Limiting Exposures: Supervise construction operations to assure that no part of the construction, completed or in progress, is subject to harmful, dangerous, damaging, or otherwise deleterious exposure during the construction period.

3.3 PROTECTION OF INSTALLED CONSTRUCTION

- A. Provide final protection and maintain conditions that ensure installed Work is without damage or deterioration at time of Substantial Completion.

3.4 CORRECTION OF THE WORK

- A. Repair or remove and replace defective construction. Restore damaged substrates and finishes. Comply with requirements in Division 1 Section "Cutting and Patching."
 - 1. Repairing includes replacing defective parts, refinishing damaged surfaces, touching up with matching materials, and properly adjusting operating equipment.
- B. Restore permanent facilities used during construction to their specified condition.

- C. Remove and replace damaged surfaces that are exposed to view if surfaces cannot be repaired without visible evidence of repair.

END OF SECTION 01700

SECTION 01731 - CUTTING AND PATCHING

PART 1 - GENERAL

1.1 RELATED DOCUMENTS

- A. Drawings and general provisions of the Contract, including General and Supplementary Conditions and other Division 1 Specification Sections, apply to this Section.

1.2 SUMMARY

- A. This Section includes procedural requirements for cutting and patching.

1.3 DEFINITIONS

- A. Cutting: Removal of in-place construction necessary to permit installation or performance of other Work.
- B. Patching: Fitting and repair work required to restore surfaces to original conditions after installation of other Work.

1.4 QUALITY ASSURANCE

- A. Structural Elements: Do not cut and patch structural elements in a manner that could change their load-carrying capacity or load-deflection ratio.
- B. Operational Elements: Do not cut and patch operating elements and related components in a manner that results in reducing their capacity to perform as intended or that results in increased maintenance or decreased operational life or safety.
- C. Miscellaneous Elements: Do not cut and patch miscellaneous elements or related components in a manner that could change their load-carrying capacity, that results in reducing their capacity to perform as intended, or that results in increased maintenance or decreased operational life or safety.
- D. Visual Requirements: Do not cut and patch construction in a manner that results in visual evidence of cutting and patching. Do not cut and patch construction exposed on the exterior or in occupied spaces in a manner that would, in Architect's opinion, reduce the building's aesthetic qualities. Remove and replace construction that has been cut and patched in a visually unsatisfactory manner.

1.5 WARRANTY

- A. Existing Warranties: Remove, replace, patch, and repair materials and surfaces cut or damaged during cutting and patching operations, by methods and with materials so as not to void existing warranties.

PART 2 - PRODUCTS

2.1 MATERIALS

- A. General: Comply with requirements specified in other Sections.
- B. In-Place Materials: Use materials identical to in-place materials. For exposed surfaces, use materials that visually match in-place adjacent surfaces to the fullest extent possible.
 - 1. If identical materials are unavailable or cannot be used, use materials that, when installed, will match the visual and functional performance of in-place materials.

PART 3 - EXECUTION

3.1 EXAMINATION

- A. Examine surfaces to be cut and patched and conditions under which cutting and patching are to be performed.
 - 1. Compatibility: Before patching, verify compatibility with and suitability of substrates, including compatibility with in-place finishes or primers.
 - 2. Proceed with installation only after unsafe or unsatisfactory conditions have been corrected.

3.2 PREPARATION

- A. Temporary Support: Provide temporary support of Work to be cut.
- B. Protection: Protect in-place construction during cutting and patching to prevent damage. Provide protection from adverse weather conditions for portions of Project that might be exposed during cutting and patching operations.
- C. Adjoining Areas: Avoid interference with use of adjoining areas or interruption of free passage to adjoining areas.

3.3 PERFORMANCE

- A. General: Employ skilled workers to perform cutting and patching. Proceed with cutting and patching at the earliest feasible time, and complete without delay.

1. Cut in-place construction to provide for installation of other components or performance of other construction, and subsequently patch as required to restore surfaces to their original condition.
- B. Cutting: Cut in-place construction by sawing, drilling, breaking, chipping, grinding, and similar operations, including excavation, using methods least likely to damage elements retained or adjoining construction. If possible, review proposed procedures with original Installer; comply with original Installer's written recommendations.
- C. Patching: Patch construction by filling, repairing, refinishing, closing up, and similar operations following performance of other Work. Patch with durable seams that are as invisible as possible. Provide materials and comply with installation requirements specified in other Sections.
 1. Inspection: Where feasible, test and inspect patched areas after completion to demonstrate integrity of installation.
 2. Exposed Finishes: Restore exposed finishes of patched areas and extend finish restoration into retained adjoining construction in a manner that will eliminate evidence of patching and refinishing.
 - a. Clean piping, conduit, and similar features before applying paint or other finishing materials.
 - b. Restore damaged pipe covering to its original condition.
 - c. Provide an even surface of uniform finish, color, texture, and appearance.
 - d. Where patching occurs in a painted surface, apply primer and intermediate paint coats over the patch and apply final paint coat over entire unbroken surface containing the patch. Provide additional coats until patch blends with adjacent surfaces.
 3. Exterior Building Enclosure: Patch components in a manner that restores enclosure to a weathertight condition.
- D. Cleaning: Clean areas and spaces where cutting and patching are performed. Completely remove paint, mortar, oils, putty, and similar materials.

END OF SECTION 01731

SECTION 01732 - SELECTIVE DEMOLITION

PART 1 - GENERAL

1.1 RELATED DOCUMENTS

- A. Drawings and general provisions of the Contract, including General and Supplementary Conditions and other Division 1 Specification Sections, apply to this Section.

1.2 SUMMARY

- A. This Section includes the following:
 - 1. Demolition and removal of selected portions of building or structure.

1.3 DEFINITIONS

- A. Remove: Detach items from existing construction and legally dispose of them off-site, unless indicated to be removed and salvaged or removed and reinstalled.
- B. Remove and Salvage: Detach items from existing construction and deliver them to Owner.
- C. Remove and Reinstall: Detach items from existing construction, prepare them for reuse, and reinstall them where indicated.
- D. Existing to Remain: Existing items of construction that are not to be removed and that are not otherwise indicated to be removed, removed and salvaged, or removed and reinstalled.

1.4 SUBMITTALS

- A. Predemolition Photographs: Show existing conditions of adjoining construction and site improvements, including finish surfaces that might be misconstrued as damage caused by selective demolition operations. Comply with Division 1 Section "Photographic Documentation." Submit before Work begins.
- B. Landfill Records: Indicate receipt and acceptance of hazardous wastes by a landfill facility licensed to accept hazardous wastes.
 - 1. Comply with submittal requirements in Division 1 Section "Construction Waste Management."

1.5 QUALITY ASSURANCE

- A. Refrigerant Recovery Technician Qualifications: Certified by an EPA-approved certification program.

- B. Regulatory Requirements: Comply with governing EPA notification regulations before beginning selective demolition. Comply with hauling and disposal regulations of authorities having jurisdiction.
- C. Standards: Comply with ANSI A10.6 and NFPA 241.
- D. Predemolition Conference: Conduct conference at Project site to comply with requirements in Division 1 Section "Project Management and Coordination."

1.6 PROJECT CONDITIONS

- A. Owner will occupy portions of building immediately adjacent to selective demolition area. Conduct selective demolition so Owner's operations will not be disrupted.
 - 1. Comply with requirements specified in Division 1 Section "Summary."
- B. Notify Owner of discrepancies between existing conditions and Drawings before proceeding with selective demolition.
 - 1. If materials suspected of containing hazardous materials are encountered, do not disturb; immediately notify Owner.
- C. Storage or sale of removed items or materials on-site is not permitted.
- D. Utility Service: Maintain existing utilities indicated to remain in service and protect them against damage during selective demolition operations.
 - 1. Maintain fire-protection facilities in service during selective demolition operations.

PART 2 - PRODUCTS (Not Used)

PART 3 - EXECUTION

3.1 EXAMINATION

- A. Verify that utilities affected by the Work have been disconnected and capped.
- B. Survey existing conditions and correlate with requirements indicated to determine extent of selective demolition required.
- C. Inventory and record the condition of items to be removed and reinstalled and items to be removed and salvaged.
- D. When unanticipated mechanical, electrical, or structural elements that conflict with intended function or design are encountered, investigate and measure the nature and extent of conflict. Promptly submit a written report to Owner.

3.2 UTILITY SERVICES AND MECHANICAL/ELECTRICAL SYSTEMS

- A. Existing Services/Systems: Maintain services/systems indicated to remain and protect them against damage during selective demolition operations.
 - 1. Comply with requirements for existing services/systems interruptions specified in Division 1 Section "Summary."
- B. Service/System Requirements: Locate, identify, disconnect, and seal or cap off indicated utility services and mechanical/electrical systems serving areas to be selectively demolished.
 - 1. Contractor shall arrange to shut off indicated services/systems when requested by Contractor.
 - 2. If services/systems are required to be removed, relocated, or abandoned, before proceeding with selective demolition provide temporary services/systems that bypass area of selective demolition and that maintain continuity of services/systems to other parts of building.
 - 3. Cut off pipe or conduit in walls or partitions to be removed. Cap, valve, or plug and seal remaining portion of pipe or conduit after bypassing.
 - a. Where entire wall is to be removed, existing services/systems may be removed with removal of the wall.

3.3 PREPARATION

- A. Site Access and Temporary Controls: Conduct selective demolition and debris-removal operations to ensure minimum interference with roads, streets, walks, walkways, and other adjacent occupied and used facilities.
 - 1. Comply with requirements for access and protection specified in Division 1 Section "Temporary Facilities and Controls."
- B. Temporary Shoring: Provide and maintain shoring, bracing, and structural supports as required to preserve stability and prevent movement, settlement, or collapse of construction and finishes to remain, and to prevent unexpected or uncontrolled movement or collapse of construction being demolished.
 - 1. Strengthen or add new supports when required during progress of selective demolition.

3.4 SELECTIVE DEMOLITION, GENERAL

- A. General: Demolish and remove existing construction only to the extent required by new construction and as indicated. Use methods required to complete the Work within limitations of governing regulations and as follows:
 - 1. Neatly cut openings and holes plumb, square, and true to dimensions required. Use cutting methods least likely to damage construction to remain or adjoining construction. Use hand tools or small power tools designed for sawing or grinding, not hammering and chopping, to minimize disturbance of adjacent surfaces. Temporarily cover openings to remain.

2. Do not use cutting torches until work area is cleared of flammable materials. At concealed spaces, such as duct and pipe interiors, verify condition and contents of hidden space before starting flame-cutting operations. Maintain fire watch and portable fire-suppression devices during flame-cutting operations.
3. Remove decayed, vermin-infested, or otherwise dangerous or unsuitable materials and promptly dispose of off-site.
4. Locate selective demolition equipment and remove debris and materials so as not to impose excessive loads on supporting walls, floors, or framing.
5. Dispose of demolished items and materials promptly.

B. Removed and Reinstalled Items:

1. Clean and repair items to functional condition adequate for intended reuse. Paint equipment to match new equipment.
2. Protect items from damage during transport and storage.
3. Reinstall items in locations indicated. Comply with installation requirements for new materials and equipment. Provide connections, supports, and miscellaneous materials necessary to make item functional for use indicated.

C. Existing Items to Remain: Protect construction indicated to remain against damage and soiling during selective demolition. .

3.5 DISPOSAL OF DEMOLISHED MATERIALS

A. General: Except for items or materials indicated to be recycled, reused, salvaged, reinstalled, or otherwise indicated to remain Owner's property, remove demolished materials from Project site and legally dispose of them in an EPA-approved landfill.

1. Do not allow demolished materials to accumulate on-site.
2. Remove and transport debris in a manner that will prevent spillage on adjacent surfaces and areas.
3. Remove debris from elevated portions of building by chute, hoist, or other device that will convey debris to grade level in a controlled descent.

B. Burning: Do not burn demolished materials.

C. Disposal: Transport demolished materials off Owner's property and legally dispose of them.

3.6 CLEANING

A. Clean adjacent structures and improvements of dust, dirt, and debris caused by selective demolition operations. Return adjacent areas to condition existing before selective demolition operations began.

END OF SECTION 01732

SECTION 01770 - CLOSEOUT PROCEDURES

PART 1 - GENERAL

1.1 RELATED DOCUMENTS

- A. Drawings and general provisions of the Contract, including General and Supplementary Conditions and other Division 1 Specification Sections, apply to this Section.

1.2 SUMMARY

- A. This Section includes administrative and procedural requirements for contract closeout, including, but not limited to, the following:
 - 1. Final completion procedures.
 - 2. Final cleaning.

1.3 FINAL COMPLETION

- A. Preliminary Procedures: Before requesting final inspection for determining date of Final Completion, complete the following:
 - 1. Submit specific warranties, workmanship bonds, maintenance service agreements, final certifications, and similar documents.
 - 2. Prepare and submit Project Record Documents, operation and maintenance manuals, and similar final record information.
 - 3. Terminate and remove temporary facilities from Project site, along with mockups, construction tools, and similar elements.
 - 4. Complete final cleaning requirements.
 - 5. Touch up and otherwise repair and restore marred exposed finishes to eliminate visual defects.
 - 6. Submit a final Application for Payment according to Division 1 Section "Payment Procedures."
 - 7. Instruct Owner's personnel in maintenance of products and systems.
 - 8. Inspection: Submit a written report of final inspection as specified in Division 7 roofing section(s).

PART 2 - PRODUCTS (Not Used)

PART 3 - EXECUTION

3.1 FINAL CLEANING

- A. General: Provide final cleaning. Conduct cleaning and waste-removal operations to comply with local laws and ordinances and Federal and local environmental and antipollution regulations.
1. Complete the following cleaning operations before Final Completion:
 - a. Clean Project site, yard, and grounds, in areas disturbed by construction activities, including landscape development areas, of rubbish, waste material, litter, and other foreign substances.
 - b. Sweep paved areas broom clean. Remove petrochemical spills, stains, and other foreign deposits.
 - c. Rake grounds that are neither planted nor paved to a smooth, even-textured surface.
 - d. Remove tools, construction equipment, machinery, and surplus material from Project site.
 - e. Clean exposed exterior hard-surfaced finishes to a dirt-free condition, free of stains, films, and similar foreign substances. Avoid disturbing natural weathering of exterior surfaces. Restore reflective surfaces to their original condition.
 - f. Remove debris and surface dust from limited access spaces, including roofs, plenums, shafts, trenches, equipment vaults, manholes, attics, and similar spaces.
 - g. Touch up and otherwise repair and restore marred, exposed finishes and surfaces. Replace finishes and surfaces that cannot be satisfactorily repaired or restored or that already show evidence of repair or restoration.
 - h. Leave Project clean and ready for occupancy.
- B. Comply with safety standards for cleaning. Do not burn waste materials. Do not bury debris or excess materials on Owner's property. Do not discharge volatile, harmful, or dangerous materials into drainage systems. Remove waste materials from Project site and dispose of lawfully.

END OF SECTION 01770

SECTION 03931 - CONCRETE DECK REHABILITATION

PART 1 - GENERAL

1.1 RELATED DOCUMENTS

- A. Drawings and general provisions of the Contract, including General and Supplementary Conditions and Division 1 Specification Sections, apply to this Section.

1.2 SUMMARY

- A. This Section includes the following:
 - 1. Rehabilitation of deteriorated concrete deck surfaces.

1.3 UNIT PRICES

- A. Unit prices include costs of field quality-control testing required by the Work for which the unit price applies.
- B. Concrete Surface Removal and Patching or Rebuilding: Work will be paid for by the square foot computed on the basis of rectangular shapes approximating the actual shape of concrete surface requiring patching, removed and replaced with average, widths, and lengths, measured to the nearest foot.

1.4 SUBMITTALS

- A. Product Data: Include material descriptions, chemical composition, physical properties, test data, and mixing and application instructions.

1.5 DELIVERY, STORAGE, AND HANDLING

- A. Deliver materials to Project site in manufacturer's original and unopened containers, labeled with type and name of products and manufacturers.
- B. Comply with manufacturer's written instructions for minimum and maximum temperature requirements and other conditions for storage.
- C. Store cementitious materials off the ground, under cover, and in a dry location.

1.6 PROJECT CONDITIONS

- A. Cold-Weather Requirements for Cementitious Materials: Comply with the following procedures:
 - 1. When air temperature is below 40 deg F, heat patching material ingredients and existing concrete to produce temperatures between 40 and 90 deg F.
 - 2. When mean daily air temperature is between 25 and 40 deg F, cover completed Work with weather-resistant insulating blankets for 48 hours after repair.
 - 3. When mean daily air temperature is below 25 deg F, provide enclosure and heat to maintain temperatures above 32 deg F within the enclosure for 48 hours after repair.

- B. Hot-Weather Requirements for Cementitious Materials: Protect repair work when temperature and humidity conditions produce excessive evaporation of water from patching materials. Provide artificial shade and wind breaks, and use cooled materials as required. Do not apply to substrates with temperatures of 90 deg F and above.

PART 2 - PRODUCTS

2.1 MANUFACTURERS

- A. Available Products: Subject to compliance with requirements, products that may be incorporated into the Work include, but are not limited to, the following:
- B. Products: Subject to compliance with requirements, provide one of the following:
 - 1. Latex Bonding Agent, Type II:
 - a. Euclid Chemical Company; FLEX-CON.
 - b. Dayton Superior Corporation; Day-Chem Ad Bond (J-40).
 - c. Kaufman Products, Inc.; SureBond.
 - 2. Cementitious Patching Mortar, Rapid Setting:
 - a. Euclid Chemical Company; EUCO-SPEED.
 - b. Kaufman Products, Inc.; Duracrete.

2.2 BONDING AGENTS

- A. Latex Bonding Agent: ASTM C 1059, Type II.

2.3 PATCHING MORTAR

- A. Cementitious Patching Mortar: Packaged, dry mix complying with ASTM C 928.

2.4 CONCRETE

2.5 MIXES

- A. Mix products in clean containers according to manufacturer's written instructions.
 - 1. Add clean silica sand and coarse aggregates to products only as recommended by manufacturer.
 - 2. Do not add water, thinners, or additives unless recommended by manufacturer.
 - 3. When practical, use manufacturer's premeasured packages to ensure that materials are mixed in proper proportions. When premeasured packages are not used, measure ingredients using graduated measuring containers; do not estimate quantities or use shovel or trowel as unit of measure.
 - 4. Do not mix more materials than can be used within recommended open time. Discard materials that have begun to set.
- B. Concrete:
 - 1. Proportion normal-weight concrete mixes to provide the following properties:
 - a. Compressive Strength: 3000 psi at 28 days.
 - b. Slump Limit: 4 inches at point of placement.
 - c. Air Content: 5.5 to 7.0 percent for concrete exposed to freezing and thawing, 2 to 4 percent elsewhere.

PART 3 - EXECUTION

3.1 EXAMINATION

- A. Locate areas of delamination using hammer or chain drag sounding and mark boundaries. Mark areas for removal by simplifying and squaring off boundaries of delaminated areas.

3.2 PREPARATION

- A. Protect people, motor vehicles, equipment, surrounding construction, Project site, plants, and surrounding buildings from injury resulting from concrete rehabilitation work.
- B. Surface Preparation for Overlays: Remove delaminated material and deteriorated concrete surface material. Roughen surface of concrete by sand blasting, shot blasting, scarifying, needle scaling, high-pressure water jetting, scabbling, flame blasting, or milling to produce a surface profile recommended by manufacturer of patching materials. Sweep and vacuum roughened surface to remove debris followed by low-pressure water cleaning.

3.3 APPLICATION

- A. Latex Bonding Agent, Type II: Mix with portland cement and scrub into concrete surface according to manufacturer's written instructions. If bonding agent dries, recoat before placing patching mortar or concrete.
- B. Patching Mortar: Unless otherwise recommended by manufacturer, apply as follows:
 - 1. Wet substrate thoroughly and then remove standing water. Scrub a slurry of neat patching mortar mixed with latex bonding agent into substrate, filling pores and voids.
 - 2. Place patching mortar by troweling toward edges of patch to force intimate contact with edge surfaces. For large patches, fill edges first and then work toward center, always troweling toward edges of patch. At fully exposed reinforcing bars, force patching mortar to fill space behind bars by compacting with trowel from sides of bars.
 - 3. After each lift is placed, consolidate material and screed surface.
 - 4. Where multiple lifts are used, score surface of lifts to provide a rough surface for application of subsequent lifts. Allow each lift to reach final set before placing subsequent lifts.
 - 5. Allow surfaces of lifts that are to remain exposed to become firm and then finish to a smooth surface with a wood or sponge float.
- C. Concrete: Place as follows:
 - 1. Apply latex bonding agent to concrete substrate.
 - 2. At unformed surfaces, screed concrete to produce a surface that when finished with patching mortar will match required profile and surrounding concrete.
 - 3. Wet-cure concrete for not less than seven days by keeping surfaces continuously wet by water-saturated absorptive cover.

END OF SECTION 03931

SECTION 05310 - STEEL DECK

PART 1 - GENERAL

1.1 RELATED DOCUMENTS

- A. Drawings and general provisions of the Contract, including General and Supplementary Conditions and Division 1 Specification Sections, apply to this Section.

1.2 SUMMARY

- A. This Section includes the following:
 - 1. Roof deck.
- B. Unit Prices: Work of this section is related to provisions of Division 1 Section "Unit Prices."

1.3 SUBMITTALS

- A. Product Data: For each type of deck, accessory, and product indicated.
- B. Product Certificates: For each type of steel deck, signed by product manufacturer.
- C. Welding certificates.
- D. Field quality-control test and inspection reports.

1.4 QUALITY ASSURANCE

- A. Welding: Qualify procedures and personnel according to AWS D1.3, "Structural Welding Code - Sheet Steel."
- B. AISI Specifications: Comply with calculated structural characteristics of steel deck according to AISI's "North American Specification for the Design of Cold-Formed Steel Structural Members."

1.5 DELIVERY, STORAGE, AND HANDLING

- A. Protect steel deck from corrosion, deformation, and other damage during delivery, storage, and handling.
- B. Stack steel deck on platforms or pallets and slope to provide drainage. Protect with a waterproof covering and ventilate to avoid condensation.

1.6 COORDINATION

- A. Comply with owners ongoing operations.

PART 2 - PRODUCTS

2.1 ROOF DECK

- A. Steel Roof Deck: Fabricate panels, without top-flange stiffening grooves, to comply with "SDI Specifications and Commentary for Steel Roof Deck," in SDI Publication No. 30, and with the following:
 - 1. Prime-Painted Steel Sheet: ASTM A 1008/A 1008M, Structural Steel (SS), Grade 33 (230) minimum, shop primed with manufacturer's standard baked-on, rust-inhibitive primer.
 - 2. Deck Profile: Match existing deck profile.
 - 3. Profile Depth: Match existing deck profile depth.
 - 4. Design Uncoated-Steel Thickness: Match existing deck steel thickness.
 - 5. Span Condition: Existing.
 - 6. Side Laps: Match existing condition.

2.2 ACCESSORIES

- A. General: Provide manufacturer's standard accessory materials for deck that comply with requirements indicated.
- B. Mechanical Fasteners: Corrosion-resistant, self-drilling, self-threading screws.
- C. Side-Lap Fasteners: Corrosion-resistant, hexagonal washer head; self-drilling, carbon-steel screws, No. 10 (4.8-mm) minimum diameter.
- D. Flexible Closure Strips: Vulcanized, closed-cell, synthetic rubber.
- E. Miscellaneous Sheet Metal Deck Accessories: Steel sheet, minimum yield strength of 33,000 psi (230 MPa), not less than 0.0359-inch (0.91-mm) design uncoated thickness, of same material and finish as deck; of profile indicated or required for application.
- F. Weld Washers: Uncoated steel sheet, shaped to fit deck rib, 0.0598 inch (1.52 mm) thick, with factory-punched hole of 3/8-inch (9.5-mm) minimum diameter.
- G. Flat Sump Plate: Single-piece steel sheet, 0.0747 inch (1.90 mm) thick, of same material and finish as deck. For drains, cut holes in the field.
- H. Galvanizing Repair Paint: ASTM A 780.
- I. Repair Paint: Manufacturer's standard rust-inhibitive primer of same color as primer.

PART 3 - EXECUTION

3.1 EXAMINATION

- A. Examine supporting frame and field conditions for compliance with requirements for installation tolerances and other conditions affecting performance.

3.2 INSTALLATION, GENERAL

- A. Install deck panels and accessories according to applicable specifications and commentary in SDI Publication No. 30, manufacturer's written instructions, and requirements in this Section.
- B. Install temporary shoring before placing deck panels, if required to meet deflection limitations.
- C. Locate deck bundles to prevent overloading of supporting members.
- D. Place deck panels on supporting frame and adjust to final position with ends accurately aligned and bearing on supporting frame before being permanently fastened. Do not stretch or contract side-lap interlocks.
- E. Place deck panels flat and square and fasten to supporting frame without warp or deflection.
- F. Cut and neatly fit deck panels and accessories around openings and other work projecting through or adjacent to deck.
- G. Comply with AWS requirements and procedures for manual shielded metal arc welding, appearance and quality of welds, and methods used for correcting welding work.
- H. Mechanical fasteners may be used in lieu of welding to fasten deck. Locate mechanical fasteners and install according to deck manufacturer's written instructions.

3.3 ROOF-DECK INSTALLATION

- A. Fasten roof-deck panels to steel supporting members by arc spot (puddle) welds of the surface diameter indicated or arc seam welds with an equal perimeter that is not less than 1-1/2 inches (38 mm) long, and as follows:
 - 1. Weld Diameter: Match welds of existing deck to remain, but not less than 5/8 inch (16 mm), nominal.
 - 2. Weld Spacing: Weld edge and interior ribs of deck units with a minimum of two welds per deck unit at each support. Space welds to match spacing of welds on existing deck units, but not less than 18 inches (450 mm) apart, maximum.
 - 3. Weld Washers: Install weld washers at each weld location.
- B. Side-Lap and Perimeter Edge Fastening: Fasten side laps and perimeter edges of panels between supports, at intervals not exceeding the lesser of 1/2 of the span or 18 inches (450 mm), and as selected from following to match existing deck unit installation:

1. Mechanically fasten with self-drilling, No. 10 (4.8-mm-) diameter or larger, carbon-steel screws.
- C. End Bearing: Install deck ends over supporting frame with a minimum end bearing of 1-1/2 inches (38 mm), with end joints as follows:
 1. End Joints: Lapped 2 inches (51 mm) minimum.
- D. Miscellaneous Roof-Deck Accessories: Install ridge and valley plates, finish strips, end closures, and reinforcing channels according to deck manufacturer's written instructions. mechanically fasten to substrate to provide a complete deck installation.
 1. Weld cover plates at changes in direction of roof-deck panels, unless otherwise indicated.
- E. Flexible Closure Strips: Install flexible closure strips over partitions, walls, and where indicated. Install with adhesive according to manufacturer's written instructions to ensure complete closure.

3.4 REPAIRS AND PROTECTION

- A. Repair Painting: Wire brush and clean rust spots, welds, and abraded areas on top surface of prime-painted deck immediately after installation, and apply repair paint.
- B. Provide final protection and maintain conditions to ensure that steel deck is without damage or deterioration at time of Substantial Completion.

END OF SECTION 05310

SECTION 06105 - MISCELLANEOUS CARPENTRY

PART 1 - GENERAL

1.1 RELATED DOCUMENTS

- A. Drawings and general provisions of the Contract, including General and Supplementary Conditions and Division 1 Specification Sections, apply to this Section.

1.2 SUMMARY

- A. This Section includes the following:
 1. Rooftop equipment bases and support curbs.
 2. Wood blocking, cants, and nailers.
 3. Sheathing.

1.3 DEFINITIONS

- A. Lumber grading agencies, and the abbreviations used to reference them, include the following:
 1. NELMA - Northeastern Lumber Manufacturers Association.
 2. NLGA - National Lumber Grades Authority.
 3. SPIB - Southern Pine Inspection Bureau.
 4. WCLIB - West Coast Lumber Inspection Bureau.
 5. WWPA - Western Wood Products Association.

1.4 SUBMITTALS

- A. Product Data: For each type of process and factory-fabricated product. Indicate component materials and dimensions and include construction and application details.
 1. Include data for wood-preservative treatment from chemical treatment manufacturer and certification by treating plant that treated materials comply with requirements. Indicate type of preservative used, net amount of preservative retained, and chemical treatment manufacturer's written instructions for handling, storing, installing, and finishing treated material.
 2. For products receiving a waterborne treatment, include statement that moisture content of treated materials was reduced to levels specified before shipment to Project site.
 3. Include copies of warranties from chemical treatment manufacturers for each type of treatment.

1.5 DELIVERY, STORAGE, AND HANDLING

- A. Stack lumber, plywood, and other panels; place spacers between each bundle to provide air circulation. Provide for air circulation around stacks and under coverings.

PART 2 - PRODUCTS

2.1 WOOD PRODUCTS, GENERAL

- A. Lumber: DOC PS 20 and applicable rules of lumber grading agencies certified by the American Lumber Standards Committee Board of Review.
 - 1. Factory mark each piece of lumber with grade stamp of grading agency.
 - 2. For exposed lumber indicated to receive a stained or natural finish, mark grade stamp on end or back of each piece.
 - 3. Where nominal sizes are indicated, provide actual sizes required by DOC PS 20 for moisture content specified. Where actual sizes are indicated, they are minimum dressed sizes for dry lumber.
 - 4. Provide dressed lumber, S4S, unless otherwise indicated.
 - 5. Provide dry lumber with 19 percent maximum moisture content at time of dressing for 2-inch nominal thickness or less, unless otherwise indicated.

- B. Wood Structural Panels:
 - 1. Plywood: Either DOC PS 1 or DOC PS 2, unless otherwise indicated.
 - 2. Thickness: As needed to comply with requirements specified but not less than thickness indicated.
 - 3. Factory mark panels according to indicated standard.

2.2 WOOD-PRESERVATIVE-TREATED MATERIALS

- A. Preservative Treatment by Pressure Process: AWWA C2 (lumber) and AWWA C9 (plywood), except that lumber that is not in contact with the ground and is continuously protected from liquid water may be treated according to AWWA C31 with inorganic boron (SBX).
 - 1. Preservative Chemicals: Acceptable to authorities having jurisdiction and one of the following:
 - a. Chromated copper arsenate (CCA).
 - b. Ammoniacal copper zinc arsenate (ACZA).
 - c. Ammoniacal, or amine, copper quat (ACQ).
 - d. Copper bis (dimethyldithiocarbamate) (CDDC).
 - e. Ammoniacal copper citrate (CC).
 - f. Copper azole, Type A (CBA-A).
 - g. Oxine copper (copper-8-quinolinolate) in a light petroleum solvent.

- B. Kiln-dry material after treatment to a maximum moisture content of 19 percent for lumber and 15 percent for plywood. Do not use material that is warped or does not comply with requirements for untreated material.

- C. Mark each treated item with the treatment quality mark of an inspection agency approved by the American Lumber Standards Committee Board of Review.
 - 1. For exposed lumber indicated to receive a stained or natural finish, mark end or back of each piece.

- D. Application: Treat items indicated on Drawings, and the following:
 - 1. Wood cants, nailers, curbs, equipment support bases, blocking, stripping, and similar members in connection with roofing, flashing, vapor barriers, and waterproofing.

2. Wood sills, blocking, and similar concealed members in contact with masonry or concrete.
3. Wood framing members less than 18 inches above grade.

2.3 MISCELLANEOUS LUMBER

- A. General: Provide lumber for support or attachment of other construction, including the following:
 1. Rooftop equipment bases and support curbs.
 2. Blocking.
 3. Cants.
 4. Nailers.
 5. Furring.
 6. Grounds.
- B. For concealed boards, provide lumber with 15 percent maximum moisture content and any of the following species and grades:
 1. Mixed southern pine, No. 2 grade; SPIB.
 2. Eastern softwoods, No. 2 Common grade; NELMA.
 3. Northern species, No. 2 Common grade; NLGA.
 4. Western woods, Construction or No. 2 Common grade; WCLIB or WWPA.

2.4 PANEL PRODUCTS

- A. Miscellaneous Concealed Plywood: Exterior sheathing, span rating to suit framing in each location, and thickness as indicated but not less than 1/2 inch.

2.5 FASTENERS

- A. General: Provide fasteners of size and type indicated that comply with requirements specified in this Article for material and manufacture.
 1. Where carpentry is exposed to weather, in ground contact, or in area of high relative humidity, provide fasteners with hot-dip zinc coating complying with ASTM A 153/A 153M or of Type 304 stainless steel.
- B. Nails, Wire, Brads, and Staples: FS FF-N-105.
- C. Power-Driven Fasteners: CABO NER-272.
- D. Wood Screws: ASME B18.6.1.
- E. Screws for Fastening to Cold-Formed Metal Framing: ASTM C 954, except with wafer heads and reamer wings, length as recommended by screw manufacturer for material being fastened.
- F. Lag Bolts: ASME B18.2.1.
- G. Bolts: Steel bolts complying with ASTM A 307, Grade A; with ASTM A 563 hex nuts and, where indicated, flat washers.

- H. Expansion Anchors: Anchor bolt and sleeve assembly of material indicated below with capability to sustain, without failure, a load equal to 6 times the load imposed when installed in unit masonry assemblies and equal to 4 times the load imposed when installed in concrete as determined by testing per ASTM E 488 conducted by a qualified independent testing and inspecting agency.
 - 1. Material: Stainless steel with bolts and nuts complying with ASTM F 593 and ASTM F 594, Alloy Group 1 or 2.

2.6 METAL FRAMING ANCHORS

- A. General: Provide galvanized steel framing anchors of structural capacity, type, and size indicated and acceptable to authorities having jurisdiction.
- B. Galvanized Steel Sheet: Hot-dip galvanized after fabrication (ASTM A 153/A 153M) or stainless steel (ASTM A 666, Type 304)

PART 3 - EXECUTION

3.1 INSTALLATION, GENERAL

- A. Discard units of material with defects that impair quality of carpentry and that are too small to use with minimum number of joints or optimum joint arrangement.
- B. Set carpentry to required levels and lines, with members plumb, true to line, cut, and fitted. Fit carpentry to other construction; scribe and cope as needed for accurate fit. Locate nailers, blocking, and similar supports to comply with requirements for attaching other construction.
- C. Apply field treatment complying with AWWA M4 to cut surfaces of preservative-treated lumber and plywood.
- D. Securely attach carpentry work as indicated and according to applicable codes and recognized standards.
- E. Countersink fastener heads on exposed carpentry work and fill holes with wood filler.
- F. Use fasteners of appropriate type and length. Pre-drill members when necessary to avoid splitting wood.

3.2 WOOD BLOCKING, AND NAILER INSTALLATION

- A. Install where indicated and where required for attaching other work. Form to shapes indicated and cut as required for true line and level of attached work. Coordinate locations with other work involved.
- B. Attach items to substrates to support applied loading. Recess bolts and nuts flush with surfaces, unless otherwise indicated.

3.3 PANEL PRODUCT INSTALLATION

- A. Wood Structural Panels: Comply with applicable recommendations contained in APA Form No. E30K, "APA Design/Construction Guide: Residential & Commercial," for types of structural-use panels and applications indicated.

END OF SECTION 06105

SECTION 06150 - WOOD DECKING

PART 1 - GENERAL

1.1 RELATED DOCUMENTS

- A. Drawings and general provisions of the Contract, including General and Supplementary Conditions and Division 1 Specification Sections, apply to this Section.

1.2 SUMMARY

- A. This Section includes the following:
 - 1. Solid-sawn roof decking.
- B. Related Sections include the following:
 - 1. Division 1 Section "Summary" for location of wood decking and repair.
 - 2. Division 6 Section "Miscellaneous Carpentry" for wood nailers, curbs, and blocking.

1.3 SUBMITTALS

- A. Product Data:
 - 1. For glued-laminated wood decking. Include installation instructions and data on fabrication.
 - 2. Include data for wood-preservative treatment from chemical treatment manufacturer and certification by treatment plant that treated materials comply with requirements. Indicate type of preservative used, net amount of preservative retained, and chemical treatment manufacturer's written instructions for handling, storing, installing, and finishing treated material.
 - a. For products receiving a waterborne treatment, include statement that moisture content of treated materials was reduced to levels specified before further fabrication or shipment to Project site.
- B. Samples: 24 inches long, showing the range of variation to be expected in appearance of wood decking.

1.4 QUALITY ASSURANCE

- A. Standard for Solid-Sawn Wood Decking: Comply with AITC 112, "Standard for Tongue-and-Groove Heavy Timber Roof Decking."
- B. Forest Certification: Provide wood decking produced from wood obtained from forests certified by an FSC-accredited certification body to comply with FSC 1.2, "Principles and Criteria."

1.5 DELIVERY, STORAGE, AND HANDLING

- A. Schedule delivery of wood decking to avoid extended on-site storage and to avoid delaying the Work.
- B. Store materials under cover and protected from weather and contact with damp or wet surfaces. Provide for air circulation within and around stacks and under temporary coverings. Stack wood decking with surfaces that are to be exposed in the final work protected from exposure to sunlight.

PART 2 - PRODUCTS

2.1 LUMBER, GENERAL

- A. General: Comply with DOC PS 20, "American Softwood Lumber Standard," and with applicable grading rules of inspection agencies certified by ALSC's Board of Review.
- B. Grade Stamps: Provide solid-sawn wood decking with each piece factory marked with grade stamp of inspection agency evidencing compliance with grading rule requirements and identifying grading agency, species, grade, moisture content at time of surfacing, and mill. Apply grade stamp to surfaces that will not be exposed to view.
- C. Moisture Content: Provide wood decking with 15 percent maximum moisture content at time of dressing.
- D. Preservative Treatment: Pressure treat solid-sawn wood decking according to AWWA C31 with inorganic boron (SBX) and redry wood to 15 percent maximum moisture content.
- E. Preservative Treatment: Where preservative-treated laminated decking is indicated, pressure treat lumber before gluing according to AWWA C28 for aboveground use.
 - 1. Use oxine copper (copper-8-quinolinolate) in a light petroleum solvent.
 - 2. Use copper naphthenate in a light petroleum solvent.
 - 3. Use ammoniacal copper zinc arsenate (ACZA) or chromated copper arsenate (CCA) in a water solution and redry wood to 15 percent maximum moisture content.
 - 4. Use preservative solution without water repellents or substances that might interfere with application of indicated finishes.

2.2 SOLID-SAWN WOOD DECKING

- A. Decking Species: Balsam fir, Douglas fir-larch, Douglas fir-larch (North), hem-fir, hem-fir (North), southern pine, spruce pine-fir (North), western hemlock, or western hemlock (North).
- B. Decking Species: Douglas fir-larch or Douglas fir-larch (North), or Southern pine.
- C. Decking Nominal Size: 2x6.
- D. Decking Grade: Commercial Decking.

- E. Decking Grade: Commercial Decking.
- F. Decking Grade: Commercial Decking.
- G. Face Surface: Smooth.
- H. Edge Pattern: Bullnosed.
- I. Adhesive: Wet-use type complying with ASTM D 2559.
 - 1. Use adhesive that contains no urea-formaldehyde resins.

2.3 FASTENERS AND ACCESSORY MATERIALS

- A. Fasteners for Solid-Sawn Decking: Provide fastener size and type complying with decking standard for thickness of deck used.
- B. Fasteners for Glued-Laminated Decking: Provide fastener size and type complying with requirements for installing laminated decking in Part 3 "Installation" Article.
- C. Fastener Material: Hot-dip galvanized steel.
- D. Installation Adhesive: For glued-laminated wood decking indicated to be of diaphragm design and construction, provide adhesive that complies with research/evaluation report.
 - 1. Use adhesive that has a VOC content of 70> g/L or less when calculated according to 40 CFR 59, Subpart D (EPA Method 24).
- E. Sealant: Latex sealant compatible with substrates.
 - 1. Use sealant that has a VOC content of 250> g/L or less when calculated according to 40 CFR 59, Subpart D (EPA Method 24).
- F. Penetrating Sealer: Clear sanding sealer complying with Division 9 painting Sections and compatible with topcoats specified for use over it.

2.4 FABRICATION

- A. Shop Fabrication: Where preservative-treated decking is indicated, complete cutting, trimming, surfacing, and sanding before treating.
- B. Fabricate decking in lengths for controlled random lay-up.
- C. Predrill decking for lateral spiking to adjacent units to comply with referenced decking standard.
- D. Seal Coat: After fabricating and surfacing decking, apply a saturation coat of penetrating sealer.

PART 3 - EXECUTION

3.1 EXAMINATION

- A. Examine walls and support framing in areas to receive wood decking for compliance with installation tolerances and other conditions affecting performance of wood decking.
 - 1. Proceed with installation only after unsatisfactory conditions have been corrected.

3.2 INSTALLATION

- A. Install solid-sawn wood decking to comply with referenced standard and with end joints located according to lay-up indicated.
- B. Where preservative-treated decking must be cut during erection, apply a field-treatment preservative to comply with AWWPA M4.
 - 1. Use inorganic boron (SBX) treatment.
 - 2. Use copper naphthenate treatment.
- C. Apply joint sealant to seal roof decking at exterior walls at the following locations:
 - 1. Between decking and supports located at exterior walls.
 - 2. Between decking and exterior walls that butt against underside of decking.
 - 3. Between tongues and grooves of decking over exterior walls and supports at exterior walls.

3.3 ADJUSTING

- A. Repair damaged surfaces and finishes after completing erection. Replace damaged decking if repairs are not approved by Architect.

3.4 PROTECTION

- A. Provide temporary waterproof covering to protect exposed decking before applying roofing.

END OF SECTION 06150

SECTION 07511 – COLD-APPLIED BUILT-UP ROOFING

PART 1 - GENERAL

1.1 RELATED DOCUMENTS

- A. Drawings and general provisions of the Contract, including General and Supplementary Conditions and Division 01 Specification Sections, apply to this Section.

1.2 SUMMARY

- A. This Section includes the following:
 - 1. Cold-applied built-up asphalt roofing system.
 - 2. Roof insulation.
 - 3. Roof surfacing consisting of aggregate surfacing.
- B. Related Sections include the following:
 - 1. Division 06 Section "Miscellaneous Rough Carpentry" for wood nailers, cants, curbs, and blocking.
 - 2. Division 07 Section "Sheet Metal Flashing and Trim" for metal roof penetration flashings, flashings, and counterflashing's.

1.3 DEFINITIONS

- A. Roofing Terminology: Refer to ASTM D 1079 and glossary of NRCA's "The NRCA Roofing and Waterproofing Manual" for definition of terms related to roofing work in this Section.

1.4 PERFORMANCE REQUIREMENTS

- A. General: Provide installed roofing membrane and base flashings that remain watertight; do not permit the passage of water; and resist specified uplift pressures, thermally induced movement, and exposure to weather without failure.
- B. Material Compatibility: Provide roofing materials that are compatible with one another under conditions of service and application required, as demonstrated by roofing manufacturer based on testing and field experience.
 - a.
- C. Flashings: Comply with requirements of Division 07 Section "Sheet Metal Flashing and Trim." Provide base flashings, perimeter flashings, detail flashings and component materials that comply with requirements and recommendations of the following:
 - 1. NRCA Roofing and Waterproofing Manual (Fifth Edition) for construction details and recommendations.

1.5 SUBMITTALS

- A. Product Certificate: Submit notarized certificate, indicating complete list of products intended for use under Work of this Section, including product names and numbers and manufacturers' names, with statement indicating that products to be provided meet the requirements of the Contract Documents.

- B. Product Data: For each type of product indicated.
 - 1. Furnish Product Data and certification letter indicating percentages by weight of post-consumer and pre-consumer recycled content for products having recycled content.
 - 2. Indicate location of material manufacturer for regionally manufactured materials.
 - C. Shop Drawings: For roofing system. Include plans, elevations, sections, details, and attachments to other Work.
 - 1. Base, perimeter, and detail flashings, cants, and membrane terminations.
 - 2. Tapered insulation, including slopes.
 - 3. Crickets, saddles, and tapered edge strips, including slopes.
 - 4. Insulation fastening patterns.
 - D. Samples for Verification: For the following products:
 - 1. 8-by-10-inch square of base sheet, ply sheet and flashing sheet.
 - 2. 8-by-10-inch square of roof insulation.
 - E. Installer Certificates: Signed by roofing system manufacturer certifying that Installer is approved, authorized, or licensed by manufacturer to install roofing system.
 - F. Manufacturer Certificates: Signed by roofing manufacturer certifying that roofing system complies with requirements specified in "Performance Requirements" Article.
 - 1. Submit evidence of meeting performance requirements.
 - G. Qualification Data: For Installer, manufacturer, and manufacturer's technical representative.
 - H. Product Test Reports: Based on evaluation of comprehensive tests performed by manufacturer and witnessed by a qualified independent testing agency, for roofing system and system components.
 - 1. Include report indicating compliance with roof system load-strain properties requirements.
 - I. Manufacturer Certificates: Indicating compliance of proposed products with requirements, including:
 - 1. Product Compatibility: Indicate manufacturer has verified compatibility of roofing system components, including but not limited to: Roofing base and ply sheets, flashing sheets, reinforcement fabric felts and mats, adhesives, mastics, coatings, and sealants.
 - 2. Adhesive Flammability: Indicate manufacturer has verified cold process adhesives and coatings are non-flammable.
 - J. Maintenance Data and Training Materials: For roofing system to include in maintenance manuals and Owner's training library.
 - K. Warranties: Copy of manufacturer's warranty that covers cold process built-up roofing system.
 - L. Inspection Reports: Copy of daily and final technical inspection reports of roofing installation.
- 1.6 QUALITY ASSURANCE
- A. Installer Qualifications: A qualified firm that is approved, authorized, or licensed by roofing system manufacturer to install manufacturer's product and that is eligible to receive manufacturer's warranty.

- B. Manufacturer's Technical Representative Qualifications: An authorized full-time employee representative of manufacturer experienced in the installation and maintenance of the specified roofing system and qualified to determine Installer's compliance with the requirements of this Project.
- C. Source Limitations: Obtain components for roofing system from or approved in writing by roofing system manufacturer.
- D. Preliminary Roofing Conference: Before starting reroofing preparation, conduct conference at Project site. Comply with requirements for pre-installation conferences in Division 01 Section "Project Management and Coordination." Review methods and procedures related to reroofing preparation and roofing system including, but not limited to, the following:
 - 1. Contractor shall be required to bring the Foreman who will be supervising this project.
 - 2. Meet with Owner, Owner's insurer if applicable, testing and inspecting agency representative, roofing installer, roofing system manufacturer's representative, and other installers whose work interfaces with or affects roofing including installers of roof accessories and roof-mounted equipment.
 - 3. Review methods and procedures related to roofing installation, including manufacturer's written instructions.
 - 4. Review and finalize construction schedule and verify availability of materials, Installer's personnel, equipment, and facilities needed to make progress and avoid delays.
 - 5. Review work restrictions and requirements for temporary facilities and controls.
 - 6. Examine substrate conditions and finishes for compliance with requirements, including flatness and fastening.
 - 7. Review structural loading limitations of roof deck during and after roofing.
 - 8. Review flashings, special roofing details, roof drainage, roof penetrations, equipment curbs, and condition of other construction that will affect roofing system.
 - 9. Review governing regulations and requirements for insurance and certificates if applicable.
 - 10. Review temporary protection requirements for roofing system during and after installation.
 - 11. Review roof observation and repair procedures after roofing installation.
 - 12.

1.7 DELIVERY, STORAGE, AND HANDLING

- A. Deliver roofing materials to Project site in original containers with seals unbroken and labeled with manufacturer's name, product brand name and type, date of manufacture, and directions for storage.
- B. Do not store materials in open or in contact with ground or roof surface.
- C. Store materials in their original undamaged containers in a clean, dry, protected location and within the temperature range required by roofing system manufacturer. Store roll goods on ends only.
- D. Protect stored liquid material from direct sunlight.
 - 1. Discard and legally dispose of liquid material that cannot be applied within its stated shelf life.

- E. Protect roof insulation materials from physical damage and from deterioration by sunlight, moisture, soiling, and other sources. Store in a dry location. Comply with insulation manufacturers written instructions for handling, storing, and protecting during installation.
- F. Handle and store roofing materials and place equipment in a manner to avoid temporary overloading or permanent deflection of deck.

1.8 PROJECT CONDITIONS

- A. Weather Limitations: Proceed with installation only when existing and forecasted weather conditions permit roofing system to be installed according to manufacturer's written instructions and warranty requirements.

1.9 WARRANTY

- A. Warranty, General: Warranties specified shall be in addition to, and run concurrent with, other warranties required by the Contract Documents. Manufacturer's disclaimers and limitations on product warranties do not relieve Contractor of obligations under requirements of the Contract Documents.
- B. Special Manufacturer's Warranty: Submit roofing system Manufacturer's special warranty, in which manufacturer agrees to repair or replace components of roofing system that fail in materials or workmanship within specified warranty period. Failure includes roof leaks.
 - 1. Special warranty includes roofing membrane, base flashings, roofing membrane accessories, roof insulation, fasteners, cover boards, and drainage systems specified in other Division 07 Sections and other components of roofing system.
 - 2. Warranty Period: 15 years from date of Substantial Completion.
- C. Special Project Warranty: Submit roofing Installer's warranty, on warranty form at end of this Section, signed by Installer, covering Work of this Section, including all components of roofing system such as roofing membrane, base flashing, roof insulation, fasteners, cover boards, sheet metal flashings and trim, for the following warranty period:
 - 1. Warranty Period: Two years from date of Substantial Completion.

PART 2 - PRODUCTS

2.1 BASE-SHEET MATERIALS

- A. Base Sheet and Flashing Backer Sheet: Nonperforated, asphalt-coated, polyester/fiberglass/polyester reinforced sheet dusted with fine mineral surfacing on both sides which exceeds the requirements of ASTM D 4601, Type II, and the following properties:
 - 1. Tensile strength @ 77-degrees, ASTM D 5147: 165 lbf MD and 150 lbf XMD
 - 2. Tear Strength @ 77-degrees, ASTM 5147: 260 lbf MD and 230 lbf XMD
 - 3. Thickness, minimum, ASTM D 5147: 60 mils
 - 4. Weight, minimum, ASTM D 5147: 38 lbs.
 - 5. Asphalt, minimum, ASTM D 228-90a: 10 lb/100 sq. ft.

2.2 ROOFING MEMBRANE PLIES

- A. Ply Sheet: ASTM D 4601, Type II, Nonperforated, asphalt-coated, fiberglass reinforced sheet dusted with fine mineral surfacing on both sides which exceeds the requirements of the following properties:
1. Breaking Strength, minimum, ASTM D 146: machine direction - 90 lbf/in, cross direction - 70 lbf/in.
 2. Pliability, ½ inch radius bend, ASTM D 146: No failures.
 3. Weight, minimum, ASTM D 228: 33 lb/100 sq. ft.
 4. Mass of desaturated glass mat, minimum, ASTM D 228: 1.7 lb/100 sq. ft.
 5. Ash, ASTM D 4601: 70 – 80%
 6. Surfacing & stabilizer, maximum, ASTM D 4601: 65%
- B. Flashing Sheet: Compounded from a blend of EPDM and SBR thermoset elastomers and reinforced with a polyester woven scrim with the following physical properties:
1. Breaking Strength, minimum, ASTM D 751: 350 lbf. MD and 300 lbf. XMD
 2. Tear Strength: ASTM D 751: 77 lbf MD & XMD
 3. Elongation ASTM D 751: 31% MD and 35% XMD
 4. Low Temperature Flexibility: ASTM D 2136: -40 deg F.
 5. Thickness, minimum, ASTM D 751: 0.045 inch.
 6. Weight, ASTM D 751: 41.6 oz/sq yd

2.3 ASPHALT MATERIALS

- A. Water-Based Asphalt Primer: Water-based, polymer modified, asphalt primer with the following physical properties:
1. Asbestos Content, EPA 600/R13/116: None.
 2. Non-Volatile Content, minimum, ASTM D 2823: 32 percent.
 3. Volatile Organic Compounds (VOC), maximum, ASTM D 3960: 65 g/L.

2.4 COLD-APPLIED ADHESIVE MATERIALS

- A. Cold-Applied Adhesive, (Roofing Plies, and Flood Coat): One-part, asbestos-free, cold-applied adhesive specially formulated for compatibility and use with specified roofing membranes and flashings, with the following physical properties:
1. Asbestos Content, EPA 600 R-93/116: None.
 2. Volatile Organic Compounds (VOC), maximum, ASTM D 6511: 250 g/L.
 3. Nonvolatile Content, minimum, ASTM D 6511: 72 percent.
 4. Flash Point, minimum, ASTM D 93: >100 deg F.
 5. Density at 77 deg F ASTM D 6511: 8.6 lb/gal.
 6. Uniformity and Consistency, ASTM D 6511: Pass.
 7. Asphalt Content, minimum, ASTM D 6511: 50 percent.
- B. Elastomeric Flashing Sheet Adhesive: One-part, solvent-free, asbestos-free, low-odor elastomeric roof mastic specially formulated for compatibility and use with specified roofing membranes and flashings, with the following properties:
1. Asbestos Content, EPA 600/R13/116: None.
 2. Volatile Organic Compounds (VOC), maximum, ASTM D 3960: less than 20 g/L.
 3. Viscosity at 77 deg. F, ASTM D2196: 600,000 0 2,000,000 cP
 4. Elongation at 77 deg. F, minimum, ASTM D 412: 300 percent.
 5. Density at 77 deg. F, ASTM D 1475: 8.6 lb/gal

6. Tensile Strength @ 77 deg. F, ASTM D 412: 30-50 psi @ 100% elongation

2.5 AUXILIARY ROOFING MEMBRANE MATERIALS

- A. General: Auxiliary materials recommended by roofing system manufacturer for intended use and compatible with built-up roofing.
- B. Asphalt Roofing Mastic: ASTM D 4586, Type II, Class 1, one-part, asbestos-free, cold-applied mastic specially formulated for compatibility and use with specified roofing membranes and flashings, with the following properties:
 1. Asbestos Content, ASTM D 276: None.
 2. Nonvolatile Matter, minimum, ASTM D 4586: 85 percent.
 3. Density at 77 deg F, ASTM D 1475: 9.5 lb/gal.
- C. Type IV Asphalt: ASTM D 312, thermoplastic hot-melt adhesive, with the following properties:
 1. Softening point, ASTM D 35: 215 – 225 deg F.
 2. Penetration @77 deg F, ASTM D 5: 15 – 25 dmm
 3. Flash point, minimum, @ 77 deg F, ASTM D92: 525 deg F.
 4. Equiviscous tem range, ASTM D 4402: 425 – 475 deg F.
- D. Fasteners: Factory-coated steel fasteners and metal or plastic plates meeting corrosion-resistance provisions in FM 4470; designed for fastening roofing membrane components to substrate; tested by manufacturer for required pullout strength; and acceptable to roofing system manufacturer.
- E. Aggregate Surfacing: ASTM D 1863, No. 6 or No. 67, clean and dry, Kunshek.
- F. Miscellaneous Accessories: Provide miscellaneous accessories recommended by roofing system manufacturer.

2.6 ROOF INSULATION

- A. General: Provide preformed roof insulation boards that comply with requirements and referenced standards, selected from manufacturer's standard sizes and of thicknesses indicated.
- B. Polyisocyanurate Board Insulation: ASTM C 1289, Type II, Class 1, Grade 2, HCFC-free, with felt or glass-fiber mat facer on both major surfaces.
 1. Refer to 01100 Summary specification section for specific insulation requirements.
- C. Provide preformed saddles, crickets, tapered edge strips, and other insulation shapes where indicated for sloping to drain. Fabricate to slopes indicated.

2.7 INSULATION ACCESSORIES

- A. General: Roof insulation accessories recommended by insulation manufacturer for intended use and compatible with membrane roofing.

- B. Fasteners: Factory-coated steel fasteners and metal or plastic plates meeting corrosion-resistance provisions in FMG 4470, designed for fastening roof insulation to substrate, and acceptable to roofing system manufacturer.
- C. Wood Fiber Cant Strips: ASTM C 208, Type II, Grade 1, cellulosic-fiber insulation board.
- D. Coverboard: ASTM C 1177/C 1177M-99, glass-mat, water-resistant gypsum substrate, with low perm heat cured top coating, ¼"-inch thick.

2.8 COATING MATERIALS

- A. Base Flashing Aluminum Coating: Aluminum pigmented roof coating with the following physical properties:
 - 1. Weight per gallon, ASTM D 1475: 8.8 ± 0.2 lbs.
 - 2. Solids (% by Weight): 61%
 - 3. Solids (% by Volume): 47%
 - 4. Metallic Content, ASTM D 2824: 15 percent.
 - 5. Reflectance , ASTM C 1549-02: >60

PART 3 - EXECUTION

3.1 EXAMINATION

- A. Examine substrates, areas, and conditions, with Installer present, for compliance with the following requirements and other conditions affecting performance of roofing system:
 - 1. Verify that roof openings and penetrations are in place and set and braced and that roof drains are securely clamped in place.
 - 2. Verify that wood cants, blocking, curbs, and nailers are securely anchored to roof deck at penetrations and terminations and that nailers match thicknesses of insulation.
 - 3. Proceed with installation only after unsatisfactory conditions have been corrected.

3.2 PREPARATION

- A. Clean substrate of dust, debris, moisture, and other substances detrimental to roofing installation according to roofing system manufacturer's written instructions. Remove sharp projections.
- B. Prevent materials from entering and clogging roof drains and conductors and from spilling or migrating onto surfaces of other construction. Remove roof-drain plugs when no work is taking place or when rain is forecast.

3.3 INSTALLATION, GENERAL

- A. Install roofing system in accordance with manufacturer's recommendations.

3.4 INSULATION INSTALLATION

- A. Coordinate installing roofing system components, so insulation is not exposed to precipitation or left exposed at the end of the workday.
- B. Comply with roofing system manufacturer's written instructions for installing roof insulation.

- C. Adhere tapered and flat stock insulation and coverboard system over concrete decks.
- D. Wood Fiber Cant Strips: Adhere and secure fiber cant strips at junctures of built-up roofing membrane system. Adhere with solid application of cold insulation adhesive.

3.5 ROOFING MEMBRANE INSTALLATION, GENERAL

- A. Install built-up roofing membrane system according to roofing system manufacturer's written instructions and applicable recommendations of ARMA/NRCA's "Quality Control Guidelines for the Application of Built-up Roofing."
- B. Start installation of built-up roofing membrane in presence of roofing system manufacturer's technical personnel.
- C. Coordinate installing roofing system components, so insulation and roofing membrane sheets are not exposed to precipitation or left exposed at the end of the workday or when rain is forecast.
 - 1. Provide tie-offs at end of each day's work to cover exposed roofing membrane sheets and insulation with a course of coated felt set in roofing cement with joints and edges sealed.
 - 2. Complete terminations and base flashings and provide temporary seals to prevent water from entering completed sections of roofing system.
 - 3. Remove and discard temporary seals before beginning work on adjoining roofing.
- D. Cold Process Asphalt Heating
 - 1. An in-line heat exchange unit may be used to facilitate application
 - a. Do not exceed maximum adhesive temperature of 100° F.
 - 2. Heat exchange unit: Use heat transfer oil approved by heating equipment manufacturer.
 - 3. Follow operation procedures recommended by heating equipment manufacturer.
- E. Substrate-Joint Penetrations: Prevent roofing asphalt from penetrating substrate joints, entering building, or damaging roofing system components or adjacent building construction.

3.6 ROOFING MEMBRANE INSTALLATION

- A. Over Concrete Decks - Prime concrete decks with asphalt primer.
 - 1. Fully adhere insulation and coverboards with hot asphalt adhesive per roofing manufactures requirements.
 - 2. Coverage shall be solid layers at 25-lbs per 100 square feet.
- B. Over Metal Decks - Mechanically Fastened Insulation: Install insulation and secure to deck using mechanical fasteners specifically designed and sized for fastening specified board-type roof insulation to deck type.
 - 1. Fasten insulation according to code requirements.
 - 2. Fasten insulation to resist uplift pressure at corners, perimeter, and field of roof.
 - 3. All layers above base layer shall be fully adhered with hot asphalt.
- C. Over Wood Decks - Mechanically attach red rosin sheet over wood decks.
 - 1. Mechanically fasten base insulation layer using mechanical fasteners specifically designed and sized for fastening specified board-type roof insulation to wood decks.
 - 2. Fasten insulation according to code requirements.
 - 3. Fasten insulation to resist uplift pressure at corners, perimeter, and field of roof.

4. All layers above base layer shall be fully adhered with hot asphalt.
- D. Install one lapped course of base sheet, over insulation, extending sheet over and terminating beyond cants. Attach base sheet as follows:
 1. Solid mop to insulation with hot roofing asphalt.
 2. Coverage shall be solid layers of 25-lbs per 100 square feet.
- E. Install three-ply sheets starting at low point of roofing system. Align ply sheets without stretching. Shingle side laps of ply sheets uniformly to achieve required number of plies throughout thickness of roofing membrane. Shingle in direction to shed water. Extend ply sheets over and terminate beyond cants.
 1. Embed each ply sheet in a solid spray application of cold, fluid-applied adhesive, not less than 2.5 gals. per 100 square feet, to form a uniform membrane without ply sheets touching.
- F. Aggregate Surfacing: Promptly after installing and testing roofing membrane, base flashing, and stripping, flood-coat roof surface with 6 gal/100 sq. ft. of cold fluid-applied adhesive. While flood coat is fluid, cast the following average weight of aggregate in a uniform course:
 1. Aggregate Weight: 500-lb/100 sq. ft.

3.7 FLASHING AND STRIPPING INSTALLATION

- A. Install base flashing over cant strips and other sloping and vertical surfaces, at roof edges, and at penetrations through roof, and secure to substrates according to roofing system manufacturer's written instructions and as follows:
 1. Prime substrates with asphalt primer if required by roofing system manufacturer.
 2. Flashing Sheet Application: Adhere flashing sheet to substrate in cold adhesive applied at rate required by roofing system manufacturer.
- B. Extend base flashing up walls or parapets a minimum of 8 inches above roofing membrane and 6 inches onto field of roofing membrane.
- C. Mechanically fasten top edge of base flashing with flat aluminum bar.
 1. Seal top termination of base flashing with a strip of glass-fiber fabric set in asphalt roofing cement.
 2. Strip-in with 3-course at base of flashing and all vertical laps (mastic, mesh, mastic)
 3. Fasten termination bar 8" on center.
- D. At perimeters fasten base flashing to wood nailers per manufacturer's recommendations.
- E. Lift vent covers and wrap base flashing over the top of the existing curbs.
- F. Install stripping, according to roofing system manufacturer's written instructions, where metal flanges and edgings are set on built-up roofing.
- G. Roof Drains: Set 30" x 30" 4 lb. lead flashing in bed of asphalt roofing cement on completed roofing membrane. Sump drain area 48" x 48". Cover metal flashing with stripping and extend a minimum of 4 inches beyond edge of metal flashing onto field of roofing membrane. Clamp roofing membrane, metal flashing, and stripping into roof-drain clamping ring.
- H. Install new 4 lb. leads over soil stacks and strip-in with 2 plies of trilaminate felt in cold mastic.

- I. Install new pitch pans with hoods around mechanical support legs, conduit, and other miscellaneous projections. Strip-in with 2 plies of tr laminate felt in cold mastic.

3.8 COATING INSTALLATION

- A. Apply two layers of aluminum coating to base flashings, plumbing pipes, drain strainers, and rusted equipment according to manufacturer's written instructions.

3.9 FIELD QUALITY CONTROL

- A. Test Cuts: Before flood coating and surfacing built-up roofing membrane, test specimens may be removed to evaluate problems observed during quality-assurance inspections of roofing membrane as follows:
 1. Approximate quantities of components within roofing membrane will be determined according to ASTM D 3617.
 2. Test specimens will be examined for interply voids according to ASTM D 3617 and to comply with criteria established in Appendix 3 of ARMA/NRCA's "Quality Control Guidelines for the Application of Built-up Roofing."
- B. Final Roof Inspection: Arrange for roofing system manufacturer's technical personnel to inspect roofing installation on completion and submit report to Owner.
 1. Notify Owner 48 hours in advance of date and time of inspection.
- C. Repair or remove and replace components of roofing system where test results or inspections indicate that they do not comply with specified requirements.
- D. Additional testing and inspecting, at Contractor's expense, will be performed to determine compliance of replaced or additional work with specified requirements.

3.10 PROTECTING AND CLEANING

- A. Protect roofing system from damage and wear during remainder of construction period. When remaining construction will not affect or endanger roofing, inspect roofing for deterioration and damage, describing its nature and extent in a written report, with copies to Owner.
- B. Correct deficiencies in or remove roofing system that does not comply with requirements, repair substrates, and repair or reinstall roofing system to a condition free of damage and deterioration at time of Substantial Completion and according to warranty requirements.
 1. Clean overspray and spillage from adjacent construction using cleaning agents and procedures recommended by manufacturer of affected construction.

END OF SECTION 07511

SECTION 07553 - SBS-MODIFIED BITUMEN MEMBRANE ROOFING

PART 1 - GENERAL

1.1 RELATED DOCUMENTS

- A. Drawings and general provisions of the Contract, including General and Supplementary Conditions and Division 1 Specification Sections, apply to this Section.

1.2 SUMMARY

- A. This Section includes the following:
 - 1. Cold applied modified bitumen membrane roofing.
 - 2. One hot applied base-ply felt.
 - 3. Hot adhesive for membrane system.
 - 4. Hot applied modified bitumen base flashings
 - 5. Roofing insulation.
- B. Related Sections include the following:
 - 1. Division 6 Section "Miscellaneous Carpentry" for wood blocking, curbs, and nailers.
 - 2. Division 7 Section "Sheet Metal Flashing and Trim" for metal roof penetration flashings, flashings, and counterflashings.

1.3 DEFINITIONS

- A. Roofing Terminology: Refer to ASTM D 1079 for definitions of terms related to roofing work not otherwise defined in this Section.
- B. Cold Applied Asphalt Adhesive – An asbestos free formulation of asphalt, solvent, thixotrope, mineral stabilizer and reinforcing fibers used as an interply adhesive and surfacing.

1.4 PERFORMANCE REQUIREMENTS

- A. General: Install a watertight, modified bitumen membrane roofing and base flashing system with compatible components that will not permit the passage of liquid water and will withstand wind loads, thermally induced movement, and exposure to weather without failure.
- B. Material Compatibility: Provide roofing materials that are compatible with one another under conditions of service and application required, as demonstrated by roofing manufacturer based on testing and field experience.
- C. Flashings: Comply with requirements of Division 7 Sections "Sheet Metal Flashing and Trim". Provide base flashings, perimeter flashings, detail flashings and component materials that comply with requirements and recommendations of the following:
 - 1. NRCA Roofing and Waterproofing Manual (Fifth Edition) for construction details and recommendations.

2. SMACNA Architectural Sheet Metal Manual (Fifth Edition) for construction details.

1.5 SUBMITTALS

- A. Product Data: For each type of roofing product specified. Include data substantiating that materials comply with requirements.
- B. Shop Drawings: Include plans, sections, details, and attachments to other work, for the following:
 1. Base flashings, cants, and membrane terminations.
 2. Tapered insulation, including slopes.
 3. Crickets, saddles, and tapered edge strips, including slopes.
- C. Samples for Verification: Of the following products:
 1. 12-by-12-inch (300-by-300-mm) square of modified bitumen, granule-surfaced cap sheets, of color specified.
 2. 12-by-12-inch (300-by-300-mm) square of roofing insulation.
 3. 6 insulation fasteners of each type, length, and finish.
- D. Installer Certificates: Signed by roofing system manufacturer certifying that Installer is approved, authorized, or licensed by manufacturer to install specified roofing system and is eligible to receive the standard roofing manufacturer's warranty.
- E. Manufacturer Certificates: Signed by roofing system manufacturer certifying that the roofing system complies with requirements specified in the "Performance Requirements" Article. Upon request, submit evidence of complying with requirements.
- F. Qualification Data: For firms and persons specified in the "Quality Assurance" Article to demonstrate their capabilities and experience. Include lists of completed projects with project names and addresses, names and addresses of architects and owners, and other information specified.
- G. Product Test Reports: Based on evaluation of comprehensive testing of current products performed by manufacturer and witnessed by a qualified independent testing agency, indicate the roof system components comply with specified requirements and are compatible with each other and suitable for use within the of roofing system.
- H. Maintenance Data: For roofing system to include in the maintenance manuals specified in Division 1.
- I. Warranty: Provide a sample copy of standard roofing manufacturer's warranty, stating obligations, remedies, limitations, and exclusions of warranty.
- J. Inspection Report: Provide a copy of the roofing system manufacturer's final inspection report of the completed roof installation.

1.6 QUALITY ASSURANCE

- A. Installer Qualifications: Engage an experienced installer to perform Work of this Section who has specialized in installing roofing similar to that required for this Project; who is approved, authorized, or licensed by the roofing system manufacturer to install manufacturer's product; and who is eligible to receive the standard roofing manufacturer's warranty.
- B. Preinstallation Conference: Before installing roofing system, conduct conference at Project site to comply with requirements of Division 1 Section "Project Meetings." Notify participants at least 5 working days before conference.
 - 1. Meet with Owner; roofing installer; roofing system manufacturer's representative; and installers whose work interfaces with or affects roofing, including installers of roof accessories and roof-mounted equipment.
 - 2. Review methods and procedures related to roofing installation, including manufacturer's written instructions.
 - 3. Examine deck substrate conditions and finishes for compliance with requirements, including flatness and attachment to structural members.
 - 4. Review loading limitations of deck during and after roofing.
 - 5. Review flashings, special roofing details, roof drainage, roof penetrations, equipment curbs, and condition of other construction that will affect roofing.
 - 6. Review governing regulations and requirements for insurance, certifications, and inspection and testing, if applicable.
 - 7. Review temporary protection requirements for roofing system during and after installation.
 - 8. Review roof observation and repair procedures after roofing installation.
 - 9. Document proceedings, including corrective measures or actions required, and furnish copy of record to each participant.

1.7 DELIVERY, STORAGE, AND HANDLING

- A. Store roofing materials in a dry, well-ventilated, weathertight location to ensure no significant moisture pickup and maintain at a temperature which does not exceed the maximum temperature given in the roofing system manufacturer's written instructions. Store rolls of felt and other sheet materials on end on pallets or other raised surfaces. Do not double-stack rolls.
 - 1. Handle and store roofing materials and place equipment in a manner to avoid significant or permanent damage to deck or structural supporting members.
- B. Do not leave unused felts and other sheet materials on the roof overnight or when roofing work is not in progress unless protected from weather and moisture and unless maintained at a temperature exceeding 50 deg F (10 deg C).
- C. Deliver and store liquid materials in their original undamaged containers in a clean, dry, protected location and within the temperature range required by roofing system manufacturer.
- D. Protect roofing insulation materials from physical damage and from deterioration by sunlight, moisture, soiling, and other sources. Store in a dry location. Comply with insulation manufacturers written instructions for handling, storing, and protecting during installation.

1.8 PROJECT CONDITIONS

- A. Weather Limitations: Proceed with roofing work only when existing and forecasted weather conditions permit roofing to be installed according to manufacturers' written instructions and warranty requirements.
- B. Prevent dust, vapors, gases, and odors from entering into the building during roof installation. When shutting down or blocking air intakes, provide makeup air or additional intake air from sources away from the work area.

1.9 WARRANTY

- A. Standard Roofing Manufacturer's Warranty: Submit a written warranty, signed by roofing system manufacturer agreeing to promptly repair leaks in the roof membrane and base flashings resulting from defects in materials or workmanship for the following warranty period:
 - 1. Warranty Period: 15 years.
- B. Project Warranty: Submit roofing Installer's warranty, signed by Installer, covering Work of this Section, including membrane roofing, base flashing, roofing insulation, fasteners, and vapor retarders, if any, for the following warranty period:
 - 1. Warranty Period: 2 years from date of Substantial Completion.

PART 2 - PRODUCTS

2.1 MANUFACTURERS

- A. Manufacturers: Subject to compliance with requirements, provide products by one of the following:
 - 1. SBS-Modified Bitumen Roof System:
 - a. Any roofing material manufacturer who can meet or exceed all specification requirements.

2.2 SBS-MODIFIED BITUMEN CAP SHEET FOR FIELD MEMBRANE AND FLASHING

- A. SBS/SEBS/SIS -Modified Bitumen Sheet, Granule Surfaced: ASTM D 6162, Type III, Grade G modified asphalt sheet, with antiwicking polyester and fiberglass mat, and continuous layer of mineral granules factory applied to top exposed surface; suitable for application method specified; manufacturer's standard thickness and weight; for use and of reinforcing type and granule color as follows:
- B. Physical Properties: Exceeds ASTM D 6162, Type III, Grade G with the following properties tested with ASTM D 5147-05:
 - 1. Thickness: 147 mils (3.7 mm).
 - 2. Tensile Strength minimum @ 77 deg F: 345 lbf/in. MD and 340 lbf/in. XMD
 - 3. Tensile Strength minimum @ 0 deg F: 410 lbf/in. in MD and 370 in XMD
 - 4. Tear Strength minimum @ 77 deg F: 600 lbf in MD and 580 in XMD
 - 5. Elongation minimum @ 77 deg F: 12.0% in MD and 8.0% in XMD

6. Low-Temperature Flexibility -40 deg F
7. Granule Color: White

2.3 BASE SHEET & PLY FOR FIELD MEMBRANE AND FLASHING

- A. A base sheet with polyester/glass scrim/glass mat trilaminate reinforcement, and coated with SBS modified waterproofing asphalt, suitable for application method specified; manufacturer's standard thickness and weight; with physical properties as follows:
- B. Physical Properties: Exceeds ASTM D 4601, Type II with the following properties:
 1. Thickness; ASTM D 146-04: 0.065 in.
 2. Weight; ASTM D 228-05: 36.9 lb/100 sq. ft.
 3. Tensile Strength, ASTM D 5147: 229 MD & 258 XMD
 4. Tear Strength, ASTM D 5147: 392 MD & 440 XMD
 5. Pliability, ½ in. radius minimum, ASTM D 146-90: No failures
 6. Asphalt, ASTM D 228-05: 12.5 lb/100 sq. ft.
 7. Elongation, ASTM D 5147-02: 6.00% MD and 7.30% XMD

2.4 AUXILIARY MEMBRANE MATERIALS

- A. General: Furnish auxiliary materials recommended by roofing system manufacturer for intended use and compatible with SBS-modified bitumen roofing.
- B. Type IV Asphalt: ASTM D 312, thermoplastic hot-melt adhesive, with the following properties:
 1. Softening point, ASTM D 35: 215 – 225 deg F.
 2. Penetration @77 deg F, ASTM D 5: 15 – 25 dmm
 3. Flash point, minimum, @ 77 deg F, ASTM D92: 525 deg F.
 4. Equiviscous temperature range, ASTM D 4402: 425 – 475 deg F.
- C. Asphalt Roofing Mastic: ASTM D 4586, Type II, Class 1, one-part, asbestos-free, cold-applied mastic specially formulated for compatibility and use with specified roofing membranes and flashings, with the following properties:
 1. Asbestos Content, ASTM D 276: None.
 2. Nonvolatile Matter, minimum, ASTM D 4586: 85 percent.
 3. Density at 77 deg F, ASTM D 1475: 9.5 lb/gal.
- D. Sealant: Polyurethane, standard or modified bituminous, elastomeric, single or multi-component.
- E. Fasteners: Factory-coated steel fasteners and metal or plastic plates complying with corrosion-resistance provisions of FM 4470; designed for fastening base sheets, base-ply felts, base flashings and for backnailing the modified bitumen membrane to the substrate; tested by manufacturer for required pullout strength; and acceptable to the roofing system manufacturer.
- F. Metal Flashing Sheet: Metal flashing sheet is specified in Division 7 Section "Sheet Metal Flashing and Trim."

- G. Roofing Granules: Ceramic-coated roofing granules, No. 11 screen size with 100 percent passing No. 8 (2.36-mm) sieve and 98 percent of mass retained on No. 40 (0.425-mm) sieve.
 - 1. Color: White.
- H. Glass-Fiber Fabric: Woven glass cloth, coated with organic resin, complying with ASTM D 1668, Type III.
- I. Miscellaneous Accessories: Provide miscellaneous accessories recommended by the roofing system manufacturer for intended use.

2.5 FLASHING ADHESIVE

- A. Type IV Asphalt: ASTM D 312, thermoplastic hot-melt adhesive, with the following properties:
 - 1. Softening point, ASTM D 35: 215 – 225 deg F.
 - 2. Penetration @77 deg F, ASTM D 5: 15 – 25 dmm
 - 3. Flash point, minimum, @ 77 deg F, ASTM D92: 525 deg F.
 - 4. Equiviscous temperature range, ASTM D 4402: 425 – 475 deg F.

2.6 INSULATION MATERIALS

- A. General: Provide preformed, roofing insulation boards that comply with requirements, selected from manufacturer's standard sizes and of thicknesses indicated.
 - 1. Provide preformed saddles, crickets, tapered edge strips, and other insulation shapes where indicated for sloping to drain. Fabricate to slopes indicated.
- B. Tapered or Flat-Stock Polyisocyanurate Board Insulation: ASTM C 1289, Type II, Class 1, Grade 2, HCFC-free, with felt or glass-fiber mat facer on both major surfaces.
 - 1. Starting Height: As stated under "Summary".
 - 2. Slope: As stated under "Summary".
- C. Coverboard: ASTM C 1177/C 1177M-99, glass-mat, water-resistant gypsum substrate, with low perm heat cured top coating, ¼ inch thick.
- D. General: Furnish roofing insulation accessories recommended by insulation manufacturer for intended use and compatible with sheet roofing material.
- E. Insulation Adhesive: Type IV Asphalt: ASTM D 312, thermoplastic hot-melt adhesive, with the following properties:
 - 1. Softening point, ASTM D 35: 215 – 225 deg F.
 - 2. Penetration @77 deg F, ASTM D 5: 15 – 25 dmm
 - 3. Flash point, minimum, @ 77 deg F, ASTM D92: 525 deg F.
 - 4. Equiviscous temperature range, ASTM D 4402: 425 – 475 deg F.
- F. Tapered Edge and Cant Strips: Rigid, cellulosic-fiber insulation board, complying with ASTM C 208, Type 2.

PART 3 - EXECUTION

3.1 EXAMINATION

- A. Examine substrates, areas, and conditions under which roofing will be applied, with Installer present, for compliance with requirements.
- B. Verify that roof openings and penetrations are in place and set and braced and that roof drains are properly clamped into position.
- C. Verify that wood blocking, curbs, and nailers are securely anchored to roof deck at roof penetrations and terminations and match the thicknesses of insulation required.
- D. Do not proceed with installation until unsatisfactory conditions have been corrected.

3.2 PREPARATION

- A. Clean substrate of dust, debris, and other substances detrimental to roofing installation according to roofing system manufacturer's written instructions. Remove sharp projections.
- B. Prevent materials from entering and clogging roof drains and conductors and from spilling or migrating onto surfaces of other construction. Remove roof-drain plugs when no work is taking place or when rain is forecast.

3.3 GENERAL INSTALLATION REQUIREMENTS

- A. Install modified bitumen membrane roofing system according to roofing system manufacturer's written instructions and applicable recommendations of NRCA/ARMA's "Quality Control Recommendations for Polymer Modified Bitumen Roofing."
 - 1. Install roofing system according to applicable specification plates of NRCA's "The NRCA Roofing and Waterproofing Manual."
- B. Begin the first day of modified bitumen roof membrane installation in the presence of roofing system manufacturer's technical personnel.
- C. Install and secure preformed 45-degree cants at all horizontal / vertical interfaces.
- D. Coordinate installation of roofing system components so insulation and roofing plies are not exposed to moisture or remain exposed at the end of the workday or when rain is forecast.
 - 1. Provide water cutoffs at the end of each day's work to cover exposed ply sheets and insulation with a course of coated felt with joints and edges sealed.
 - 2. Complete terminations and base flashings and provide temporary seals to prevent water from entering completed sections of the roofing system.
- E. Remove and discard temporary seals before beginning work on adjoining
- F. Shingling Plies: Install modified bitumen membrane roofing system with ply sheets shingled uniformly to achieve required number of membrane plies throughout. Shingle in direction to shed water.
- G. Cooperate with inspecting and testing agencies engaged or required to perform services for installing modified bitumen membrane roofing system.

- H. Phased construction is not permitted. Install base plies and modified bitumen membrane on the same day.
- I. Substrate-Joint Penetrations: Prevent cold process asphalt adhesive from penetrating substrate joints, entering building, or damaging roofing system components or adjacent building construction.

3.4 INSULATION INSTALLATION

- A. Coordinate installing roofing system components, so insulation is not exposed to precipitation or left exposed at the end of the workday.
- B. Comply with roofing system manufacturer's written instructions for installing roofing insulation.
- C. Install tapered edge strips at perimeter edges of roof that do not terminate at vertical surfaces.
- D. Install one or more layers of insulation under area of roofing to achieve required thickness. Where overall insulation thickness is 2 inches (50 mm) or greater, install required thickness in 2 or more layers with joints of each succeeding layer staggered from joints of previous layer a minimum of 6 inches (150 mm) in each direction.
- E. Trim surface of insulation where necessary at roof drains so completed surface is flush with ring of drain.
- F. Install insulation with long joints of insulation in continuous straight lines with end joints staggered between rows, abutting edges and ends between boards. Fill gaps exceeding 1/4 inch (6 mm) with insulation.
 - 1. Cut and fit insulation within 1/4 inch (6 mm) of nailers, projections, and penetrations.

3.5 BASE-PLY FELT INSTALLATION

- A. Install base-ply felts according to roofing system manufacturer's written instructions, starting at low point of roofing system. End lap and shingle each base-ply felt to ensure the specified number of base-ply felts covers the substrate at any point. Extend base-ply felts over and terminate beyond cants. Embed each base-ply felt in a continuous application of cold applied adhesive applied at the rate required by the roofing system manufacturer, to form a uniform membrane so that ply felts do not touch each other.
 - 1. Install 1-ply of base-ply felt.

3.6 ROOF MEMBRANE INSTALLATION

- A. General: Install modified bitumen membrane over area to receive roofing, according to manufacturer's written instructions. Extend modified bitumen membrane over and terminate beyond cants.
 - 1. Unroll sheet and allow it to relax for the minimum time period required by manufacturer.

- B. Single-Ply, Modified Bitumen Membrane: Install a single ply of modified bitumen membrane starting at low point of roofing system.
 - 1. Application: Adhere to substrate in a continuous application of hot adhesive applied at rate required by roofing system manufacturer.
 - 2. Immediately roll membrane with a 70-lbs. steel roller.
- C. Laps: Accurately align sheets, without stretching, and maintain uniform side and end laps. Stagger end laps. Completely bond and seal laps, leaving no voids.
 - 1. Repair tears and voids in laps and lapped seams not completely sealed.
 - 2. Apply granules, while asphalt is hot, to cover asphalt bead exuded at laps.
- D. Install modified bituminous membranes with side laps shingled with slope of roof deck.

3.7 FLASHING AND STRIPPING INSTALLATION

- A. Install 2-ply MB base flashing over cant strips and other sloping and vertical surfaces, at roof edges, and at penetrations through roof, and secure to substrates according to roofing system manufacturer's written instructions and as follows:
 - 1. Prime substrates with water-based asphalt primer if required by roofing system manufacturer.
 - 2. Adhere 2-ply base flashing system in a full and continuous application of hot asphalt mastic, applied at the rate required by the roofing system manufacturer.
- B. Extend base flashing up the wall a minimum of 8 inches (200 mm) above roof membrane and 4 inches (100 mm) onto field of roof membrane.
- C. Mechanically fasten top of MB sheet base flashing securely at terminations and perimeter of roofing.
 - 1. Seal top termination of base flashing.
 - 2. Seal bottom and side lap termination of reinforced elastomeric sheet base flashing with a strip of glass-fiber fabric set in elastomeric flashing adhesive and covered with a course of elastomeric mastic.
- D. Install modified bitumen stripping where metal flanges and edgings are set on membrane roofing, according to roofing system manufacturer's written instructions.
- E. Roof Drains: Set 30-by-30-inch (760-by-760-mm) 4-lb lead flashing in bed of asphalt roofing cement on completed modified bitumen membrane roofing. Cover lead flashing with modified bitumen stripping extending a minimum of 4 inches (100 mm) beyond edge of lead flashing onto field of roof membrane. Clamp roof membrane, lead flashing, and stripping into roof-drain clamping ring.

3.8 FIELD QUALITY CONTROL

- A. Final Roof Inspection: Arrange for roofing system manufacturer's technical personnel to inspect roofing installation on completion and submit report to Owner.
 - 1. Notify Owner 48 hours in advance of the date and time of inspection.

3.9 PROTECTING AND CLEANING

- A. Protect modified bitumen membrane roofing from damage and wear during remainder of construction period. When remaining construction will not affect or jeopardize roofing, inspect roofing for deterioration and damage, describing its nature and extent in a written report, with copies to Owner.
- B. Correct deficiencies in or remove modified bituminous roofing that does not comply with requirements, repair substrates, reinstall roofing, and repair base flashings to a condition free of damage and deterioration at the time of Substantial Completion and according to warranty requirements.
- C. Clean overspray and spillage from adjacent construction using cleaning agents and procedures recommended by manufacturer of affected construction.

END OF SECTION 07553

SECTION 07591 - MEMBRANE REROOFING PREPARATION

PART 1 - GENERAL

1.1 RELATED DOCUMENTS

- A. Drawings and general provisions of the Contract, including General and Supplementary Conditions and Division 1 Specification Sections, apply to this Section.

1.2 SUMMARY

- A. This Section includes the following:
 - 1. Protection of existing roofing system that is not reroofed.

1.3 MATERIALS OWNERSHIP

- A. Except for items or materials indicated to be reused, reinstalled, or otherwise indicated to remain Owner's property, demolished materials shall become Contractor's property and shall be removed from Project site and disposed of legally.

1.4 DEFINITIONS

- A. Roofing Terminology: Refer to ASTM D 1079 and glossary in NRCA's "The NRCA Roofing and Waterproofing Manual" for definition of terms related to roofing work in this Section.
- B. Existing Membrane Roofing System: Built-up asphalt and coal-tar pitch roofing membrane, surfacing, and components and accessories between deck and roofing membrane.
- C. Substrate Board: Rigid board or panel products placed over the roof deck that serve as thermal barriers, provide a smooth substrate, or serve as a component of a fire-resistance-rated roofing system.
- D. Roof Tear-Off: Removal of existing membrane roofing system from deck.
- E. Remove: Detach items from existing construction and legally dispose of them off-site unless indicated to be removed and reinstalled.
- F. Existing to Remain: Existing items of construction that are not indicated to be removed.

1.5 SUBMITTALS

- A. Product Data: For each type of product indicated.
- B. Fastener pull-out test report.

- C. Photographs or Videotape: Show existing conditions of adjoining construction and site improvements, including exterior and interior finish surfaces, which might be misconstrued as having been damaged by reroofing operations. Submit before Work begins.

1.6 QUALITY ASSURANCE

- A. Regulatory Requirements: Comply with governing EPA notification regulations before beginning membrane roofing removal. Comply with hauling and disposal regulations of authorities having jurisdiction.
- B. Reroofing Conference: Conduct conference at Project site to comply with requirements in Division 1 Section "Project Management and Coordination." Review methods and procedures related to roofing system including, but not limited to, the following:
 - 1. Meet with Owner; Owner's insurer if applicable; testing and inspecting agency representative; roofing system manufacturer's representative; roofing Installer including project manager, superintendent, and foreman; and installers whose work interfaces with or affects reroofing including installers of roof accessories and roof-mounted equipment.
 - 2. Review methods and procedures related to reroofing preparation, including membrane roofing system manufacturer's written instructions.
 - 3. Review temporary protection requirements for existing roofing system that is to remain, during and after installation.
 - 4. Review roof drainage during each stage of reroofing and review roof drain plugging and plug removal procedures.
 - 5. Review and finalize construction schedule, and verify availability of materials, Installer's personnel, equipment, and facilities needed to make progress and avoid delays.
 - 6. Review existing deck removal procedures and Owner notifications.
 - 7. Review procedures to determine condition and acceptance of existing deck for reuse.
 - 8. Review structural loading limitations of deck during reroofing.
 - 9. Review base flashings, special roofing details, drainage, penetrations, equipment curbs, and condition of other construction that will affect reroofing.
 - 10. Review HVAC shutdown and sealing of air intakes.
 - 11. Review shutdown of fire-suppression, -protection, and -alarm and -detection systems.
 - 12. Review procedures for asbestos removal or unexpected discovery of asbestos-containing materials.
 - 13. Review governing regulations and requirements for insurance and certificates if applicable.
 - 14. Review existing conditions that may require notification of Owner before proceeding.

1.7 PROJECT CONDITIONS

- A. Owner will occupy portions of building immediately below reroofing area. Conduct reroofing so Owner's operations will not be disrupted. Provide Owner with not less than 72 hours' notice of activities that may affect Owner's operations.
 - 1. Coordinate work activities daily with Owner so Owner can place protective dust or water leakage covers over sensitive equipment or furnishings, shut down HVAC and fire-alarm or -detection equipment if needed, and evacuate occupants from below the work area if desired.

- B. Protect building to be reroofed, adjacent buildings, walkways, site improvements, exterior plantings, and landscaping from damage or soiling from reroofing operations.
- C. Maintain access to existing walkways, corridors, and other adjacent occupied or used facilities. Do not block required exits or path from required exit to public right-of-way. Coordinate with requirements of authorities having jurisdiction.
- D. Owner assumes no responsibility for condition of areas to be reroofed.
- E. Weather Limitations: Proceed with reroofing preparation only when existing and forecasted weather conditions permit Work to proceed without water entering into existing roofing system or building.
- F. Hazardous Materials: It is not expected that hazardous materials such as asbestos-containing materials will be encountered in the Work.
 - 1. If materials suspected of containing hazardous materials are encountered, do not disturb; immediately notify Owner. Hazardous materials will be removed by Owner under a separate contract.

PART 2 - PRODUCTS

2.1 INFILL MATERIALS

- A. Use infill materials matching existing decks, unless otherwise indicated.
 - 1. Infill materials are specified in Division 7 Section "COLD OR HOT APPLIED ASPHALT BUILT-UP ROOFING "

2.2 AUXILIARY REROOFING MATERIALS

- A. General: Auxiliary reroofing preparation materials recommended by roofing system manufacturer for intended use and compatible with components of new membrane roofing system.
- B. Base Sheet Fasteners: Capped head, factory-coated steel fasteners, listed in FMG's "Approval Guide."
- C. Metal Flashing Sheet: Metal flashing sheet is specified in Division 7 Section "Sheet Metal Flashing and Trim."

PART 3 - EXECUTION

3.1 PREPARATION

- A. Coordinate with Owner to shut down air intake equipment in the vicinity of the Work. Cover air intake louvers before proceeding with reroofing work that could affect indoor air quality or activate smoke detectors in the ductwork.

- B. During removal operations, have sufficient and suitable materials on-site to facilitate rapid installation of temporary protection in the event of unexpected rain.
- C. Maintain roof drains in functioning condition to ensure roof drainage at end of each workday. Prevent debris from entering or blocking roof drains and conductors. Use roof-drain plugs specifically designed for this purpose. Remove roof-drain plugs at end of each workday, when no work is taking place, or when rain is forecast.
 - 1. If roof drains will be temporarily blocked or unserviceable due to roofing system removal or partial installation of new membrane roofing system, provide alternative drainage method to remove water and eliminate ponding. Do not permit water to enter into or under existing membrane roofing system components that are to remain.
- D. Verify that rooftop utilities and service piping have been shut off before commencing Work.

3.2 ROOF TEAR-OFF

- A. General: Notify Owner each day of extent of roof tear-off proposed and obtain authorization to proceed.
- B. Remove loose aggregate from aggregate-surfaced built-up bituminous roofing with a power broom.
- C. Partial Roof Tear-Off: Where indicated, remove existing roofing membrane and immediately check for presence of moisture by visually observing roof insulation.
 - 1. Coordinate with Owner's inspector to schedule times for tests and inspections immediately after membrane removal.
- D. Complete Roof Tear-Off:
 - 1. Remove all roofing, insulation, and flashing with metal terminations down to decks.
 - 2. Sweep decks clean of all dirt, dust, and debris.
 - a. Do not leave tear-off debris on decks.

3.3 DECK PREPARATION

- A. Inspect deck after partial tear-off of membrane roofing system.
- B.** If broken or loose fasteners that secure deck panels to one another or to structure are observed, or if deck appears or feels inadequately attached, immediately notify Owner. Do not proceed with installation until directed by Owner.
- C. If deck surface is not suitable for receiving new roofing, or if structural integrity of deck is suspect, immediately notify Owner. Do not proceed with installation until directed by Owner.
- D. Replace deck as needed. Replacement deck is specified in Division 5 Section "Steel Deck."

3.4 EXISTING BASE FLASHINGS

- A. Remove existing base flashings around parapets, curbs, walls, and penetrations.
 - 1. Clean substrates of contaminants such as asphalt, sheet materials, dirt, and debris.
- B. Do not damage metal counterflashings that are to remain. Replace metal counterflashings damaged during removal with counterflashings of same metal, weight or thickness, and finish.

3.5 FASTENER PULL-OUT TESTING

- A. Perform fastener pullout tests as required by Owner, and submit test report to Owner before installing new membrane roofing system.
 - 1. Furnish detailed proposal to Owner for revised fastening pattern commensurate with pull-out test results.

3.6 INSULATION BOARD INSTALLATION

- A. Install insulation boards over roof decks with long joints in continuous straight lines and end joints staggered between rows. Loosely butt recover boards together and fasten to deck.
 - 1. Fasten or adhere bottom layer to resist wind-uplift pressure at corners, perimeter, and field of roof specified in Division 7 Section "COLD OR HOT APPLIED ASPHALT BUILT-UP ROOFING."
 - 2. Install additional fasteners or adhesive near board corners and edges as necessary to conform boards to substrate and to adjacent boards.
 - 3. Adhere top layer as specified in Division 7 Section "HOT OR COLD APPLIED ASPHALT BUILT-UP ROOFING."

3.7 DISPOSAL

- A. Collect and place demolished materials in containers. Promptly dispose of demolished materials. Do not allow demolished materials to accumulate on-site.
 - 1. Storage or sale of demolished items or materials on-site will not be permitted.
- B. Transport demolished materials off Owner's property and legally dispose of them.

END OF SECTION 07591

SECTION 07591 - MEMBRANE REROOFING PREPARATION AND RESTORATION

PART 1 - GENERAL

1.1 RELATED DOCUMENTS

- A. Drawings and general provisions of the Contract, including General and Supplementary Conditions and Division 1 Specification Sections, apply to this Section.

1.2 SUMMARY

- A. This Section includes the following:
 - 1. Repair of base flashings.
 - 2. Protection of existing roofing system that is not reroofed.
 - 3. Restored specified roof areas per roofing material manufacturers recommendations.

1.3 MATERIALS OWNERSHIP

- A. Except for items or materials indicated to be reused, reinstalled, or otherwise indicated to remain Owner's property, demolished materials shall become Contractor's property and shall be removed from Project site and disposed of legally.

1.4 DEFINITIONS

- A. Roofing Terminology: Refer to ASTM D 1079 and glossary in NRCA's "The NRCA Roofing and Waterproofing Manual" for definition of terms related to roofing work in this Section.
- B. Existing Membrane Roofing System: Cold process BUR with gravel surfacing, and components and accessories between deck and roofing membrane.
- C. Partial Roof Tear-Off: Removal of a portion of existing membrane roofing system from deck or removal of selected components and accessories from existing membrane roofing system. Areas indicated as wet by thermal scan.
- D. Remove: Detach items from existing construction and legally dispose of them off-site unless indicated to be removed and reinstalled.
- E. Existing to Remain: Existing items of construction that are not indicated to be removed.

1.5 SUBMITTALS

- A. Product Data: For each type of product indicated.

1.6 QUALITY ASSURANCE

- A. Regulatory Requirements: Comply with governing EPA notification regulations before beginning membrane-roofing removal. Comply with hauling and disposal regulations of authorities having jurisdiction.
- B. Reroofing Conference: Conduct conference at Project site to comply with requirements in Division 1 Section "Project Management and Coordination." Review methods and procedures related to roofing system including, but not limited to, the following:
 - 1. Meet with Owner; Owner's insurer if applicable; testing and inspecting agency representative; roofing system manufacturer's representative; roofing Installer including project manager, superintendent, and foreman; and installers whose work interfaces with or affects reroofing including installers of roof accessories and roof-mounted equipment.
 - 2. Review methods and procedures related to reroofing preparation, including membrane roofing system manufacturer's written instructions.
 - 3. Review temporary protection requirements for existing roofing system that is to remain, during and after installation.
 - 4. Review roof drainage during each stage of reroofing and review roof drain plugging and plug removal procedures.
 - 5. Review and finalize construction schedule, and verify availability of materials, Installer's personnel, equipment, and facilities needed to make progress and avoid delays.
 - 6. Review existing deck removal procedures and Owner notifications.
 - 7. Review procedures to determine condition and acceptance of existing deck for reuse.
 - 8. Review structural loading limitations of deck during reroofing.
 - 9. Review base flashings, special roofing details, drainage, penetrations, equipment curbs, and condition of other construction that will affect reroofing.
 - 10. Review HVAC shutdown and sealing of air intakes.
 - 11. Review shutdown of fire-suppression, -protection, and -alarm and -detection systems.
 - 12. Review procedures for asbestos removal or unexpected discovery of asbestos-containing materials.
 - 13. Review governing regulations and requirements for insurance and certificates if applicable.
 - 14. Review existing conditions that may require notification of Owner before proceeding.

1.7 PROJECT CONDITIONS

- A. Protect building to be reroofed, adjacent buildings, walkways, site improvements, exterior plantings, and landscaping from damage or soiling from reroofing operations.
- B. Maintain access to existing walkways, corridors, and other adjacent occupied or used facilities. Do not block required exits or path from required exit to public right-of-way. Coordinate with requirements of authorities having jurisdiction.
- C. Owner assumes no responsibility for condition of areas to be reroofed.
- D. Weather Limitations: Proceed with reroofing preparation only when existing and forecasted weather conditions permit Work to proceed without water entering into existing roofing system or building.
 - 1. If materials suspected of containing hazardous materials are encountered, do not disturb; immediately notify Owner.

1.8 WARRANTY

- A. Roofing Recoating Warranty, General: Warranties specified shall be in addition to, and run concurrent with, other warranties required by the Contract Documents. Manufacturer's disclaimers and limitations on product warranties do not relieve Contractor of obligations under requirements of the Contract Documents.
- B. Special Warranty for Roof Recoating: Written warranty in which Manufacturer agrees to repair roof recoating installations that fail in materials or workmanship within specified warranty period.
 - 1. Failures include, but are not limited to, the following:
 - a. Leaks
 - 2. Qualified Installer Requirement: Installer must meet requirements of Quality Assurance Article.
 - 3. Warranty Period: 10 years from date of completion of recoating work.

PART 2 - PRODUCTS

2.1 ROOF MEMBRANE ADHESIVE AND FELT FOR WET INSULATION AREAS

- 1. Cold-Applied Adhesive: One-part, solvent-free, asbestos-free, cold-applied adhesive specially formulated for compatibility and use with specified roofing membranes and flashings, with the following physical properties:
 - a. Asbestos Content, EPA 600 R-93/116: None.
 - b. Volatile Organic Compounds (VOC), maximum, ASTM D 6511: 40 g/L.
 - c. Nonvolatile Content, minimum, ASTM D 6511: 96.4 percent.
 - d. Density at 77 deg F ASTM D 6511: 8.8 lb/gal.
- 2. Interply felts: Nonperforated, asphalt-coated, polyester/fiberglass/polyester reinforced sheet dusted with fine mineral surfacing on both sides which exceeds the requirements of ASTM D 4601, Type II, and the following properties:
 - a. Tensile Strength @ 77-degrees, ASTM D 5147: 165 lbf MD and 150 lbf XMD
 - b. Tear Strength @ 77-degrees, ASTM D 5147: 260 lbf MD and 230 lbf XMD
 - c. Thickness, minimum, ASTM D 5147: 60 mils
 - d. Weight, minimum, ASTM D 5147: 38 lbs.
 - e. Asphalt, minimum, ASTM D 228-90a: 10 lb/100 sq. ft.

2.2 ROOFING REPAIR MATERIALS

A. ROOFING MASTIC FOR REINFORCEMENT

- 1. Solvent-Free Elastomeric Roofing Mastic: One-part, solvent-free, asbestos-free, low-odor elastomeric roof mastic specially formulated for compatibility and use with specified roofing membranes and flashings, with the following properties:
 - a. Asbestos Content, EPA 600/R13/116: None.
 - b. Volatile Organic Compounds (VOC), maximum, ASTM D 3960: 300 g/L.
 - c. Nonvolatile Matter, minimum, ASTM D 4586: 70 percent.
 - d. Elongation at 77 deg. F, minimum, ASTM D 412: 1000 percent.
 - e. Recovery from 500% Elongation, minimum, ASTM D 412: 500 percent.
 - f. Flexibility at -40 deg. F, ASTM D 3111: No Cracking.

2.3 RESTORATION MATERIALS

A. PRIMER

1. Water-Based Asphalt Primer: Water-based, polymer modified, asphalt primer with the following physical properties:
 - a. Asbestos Content, EPA 600/R13/116: None.
 - b. Non-Volatile Content, minimum, ASTM D 2823: 32 percent.
 - c. Volatile Organic Compounds (VOC), maximum, ASTM D 3960: 65 g/L.

B. SURFACING ADHESIVE

1. Asphalt Emulsion: One-part, asbestos-free, cold-applied, emulsified blend of special aromatic oils and additives formulated to be compatible with both tar and asphalt built-up roof membranes.
 - a. Asbestos Content, ASTM D 276: None.
 - b. Density at 77 deg. F, minimum, ASTM D 1475: 8.6 lb/gal.
 - c. Water content, minimum, ASTM D 3792: 40%
 - d. Volatile Organic Compounds (VOC), maximum, ASTM D 3960: 29 g/L.

C. FLASHING COATING: Two-coat polyurethane elastomeric coating system consisting of a two-part, bio-based base coat and top coat with the following properties:

1. Base Coat:
 - a. Tensile Strength, ASTM D412: 644 psi
 - b. Elongation, ASTM D412: 62%
 - c. Volatile Organic Content, ASTM D 3960: 1 g/L (A+B mix)
 - d. Volume Solids, ASTM D 2697: 100%
 - e. Weight Solids, ASTM D 1644: 100%
 - f. Tear Resistance, ASTM D5147: 294 lbf/in
 - g. Breaking Strength, ASTM D751: 385 lbf/in
 - h. Low Temperature Flexibility, ASTM D5147: Pass at -30-degrees
2. Top Coat:
 - a. Tensile Strength, ASTM D412: 644 psi
 - b. Elongation, ASTM D412: 62%
 - c. Volatile Organic Content, ASTM D 3960: 16 g/L (A+B mix)
 - d. Volume Solids, ASTM D 2697: 100%
 - e. Weight Solids, ASTM D 1644: 100%
 - f. Tear Resistance, ASTM D5147: 294 lbf/in
 - g. Breaking Strength, ASTM D751: 385 lbf/in
 - h. Solar Reflectivity, ASTM C1549: Initial – 0.83, 3-Yr. Aged – 0.82
 - i. Thermal Emittance, ASTM C1371: Initial – 0.90, 3-Yr. Aged – 0.90

D. SURFACING

1. Aggregate Surfacing: ASTM D 1863, No. 6 or No. 67, clean, dry, opaque, Kunshek water-worn gravel or crushed stone, free of sharp edges.

2.4 AUXILIARY REROOFING MATERIALS

- A. General: Auxiliary materials recommended by roofing system manufacturer for intended use and compatible with built-up roofing.

- B. Fasteners: Factory-coated steel fasteners and metal or plastic plates meeting corrosion-resistance; designed for fastening roofing membrane components to substrate; tested by manufacturer for required pullout strength; and acceptable to roofing system manufacturer.
- C. Protection Treads: As recommended by roofing material manufacturer.
 - 1. Granule Color: White.
- D. Miscellaneous Accessories: Provide miscellaneous accessories recommended by roofing system manufacturer.

PART 3 - EXECUTION

3.1 PREPARATION

- A. Protect existing membrane roofing system that is indicated not to be reroofed.
 - 1. Limit traffic and material storage to areas of existing roofing membrane that have been protected.
 - 2. Maintain temporary protection and leave in place until replacement roofing has been completed.
- B. During removal operations, have enough and suitable materials on-site to facilitate rapid installation of temporary protection in the event of unexpected rain.
- C. Maintain roof drains in functioning condition to ensure roof drainage at end of each workday. Prevent debris from entering or blocking roof drains and conductors. Use roof-drain plugs specifically designed for this purpose. Remove roof-drain plugs at end of each workday, when no work is taking place, or when rain is forecast.
 - 1. If roof drains will be temporarily blocked or unserviceable due to roofing system removal or partial installation of new membrane roofing system, provide alternative drainage method to remove water and eliminate ponding. Do not permit water to enter into or under existing membrane roofing system components that are to remain.
- D. Verify that rooftop utilities and service piping have been shut off before commencing Work.

3.2 ROOF TEAR-OFF – WET AREAS ONLY

- A. General: Notify Owner each day of extent of roof tear-off proposed and obtain authorization to proceed.
- B. Partial Roof Tear-Off: Where indicated by infrared marking, remove existing roofing membrane and immediately check for presence of moisture by visually observing roof insulation.
 - 1. Remove all roofing, insulation, and flashing with metal terminations down to decks.
 - 2. Sweep decks clean of all dirt, dust, and debris.
 - a. Do not leave tear-off debris on decks.
 - 3. Install new insulation to match existing in type and thickness per roofing manufacturers requirements.

4. Install 3-ply of trilaminate plies in cold asphalt adhesive per roofing manufacturers requirements.

3.3 FLASHING REPAIR

- A. Do not damage metal counterflashing's that are to remain. Replace metal counterflashing's damaged during removal with counterflashing's of same metal, weight or thickness, and finish.
- B. Repair flashings, gravel stops, copings, and other roof-related sheet metal and trim elements. Reseal joints, replace loose or missing fasteners, and replace components where required to leave in a watertight condition.
 1. Install 3-course reinforcement on all vertical laps and corners as specified under Section 01100 "Summary".
 2. Install 5-course reinforcement on all drains, plumbing pipes, stacks, and pitch pans as specified under Section 01100 "Summary".

3.4 FLASHING RE-COATING

- A. Reinforcement: Apply one layer of base coat to all flashing laps, vertical and horizontal, in accordance with manufacturer's written instructions. Immediately imbed one layer of polyester reinforcement and back roll to fully embed. Apply base coat over reinforcement in accordance with manufacturer's written instructions.
- B. Base Coat: Apply base coat to all flashing surfaces in accordance with manufacturer's written instructions. Back roll to achieve minimum wet mil coating thickness of 2.5 gallons per 100 square feet unless otherwise recommended by manufacturer, verify thickness of base coat as work progresses.
 1. Apply base coat on prepared and primed surfaces and spread coating evenly.
 2. Allow base coat to cure prior to application of top coat.
- C. Top Coat: Apply top coat to all flashing surfaces uniformly in a complete installation to flashing surfaces.
 1. Prime base coat prior to application of top coat if top coat is not applied within 72 hours of the base coat application, using manufacturer's recommended primer.
 2. Apply top coat to flashings extending coating up vertical surfaces and out onto horizontal surfaces.
 3. Back roll to achieve wet mil thickness of 2 gallon per 100 square feet unless otherwise recommended by manufacturer.

3.5 ROOF RE-COATING

- A. Restorative Flood Coat: Promptly after preparing membrane substrate and base flashings and stripping, flood-coat roof surface with 7 gal./100 sq. ft. of restorative coating.
- B. Kunshek Aggregate Surfacing: While flood coat is fluid, cast the following average weight of aggregate in a uniform course:
 1. Aggregate Weight: 550 lb./100 sq. ft.
 2. Install more gravel as needed to completely cover the new flood coat adhesive.

3.6 DISPOSAL

- A. Collect and place demolished materials in containers. Promptly dispose of demolished materials. Do not allow demolished materials to accumulate on-site.
 - 1. Storage or sale of demolished items or materials on-site will not be permitted.
- B. Transport demolished materials off Owner's property and legally dispose of them.

3.7 SCHEDULE OF SPECIAL WARRANTIES AND SERVICE AGREEMENTS

- A. The following documents are referenced in this Section and are attached following this Section; complete and submit similar documents in accordance with requirements:
 - 1. Roofing Installer's Warranty
 - 2. Roofing System Manufacturer's Continuing Maintenance Program

3.8 ROOFING INSTALLER'S WARRANTY

- A. WHEREAS _____ of _____, herein called the "Roofing Installer," has performed roofing and associated work ("work") on the following project:
 - 1. Owner: _____
 - 2. Address: _____
 - 3. Building Name/Type: _____
 - 4. Address: _____
 - 5. Area of Work: _____
 - 6. Acceptance Date: _____
 - 7. Warranty Period: Two years from the date of substantial completion
 - 8. Expiration Date: _____
- B. AND WHEREAS Roofing Installer has contracted (either directly with Owner or indirectly as a subcontractor) to warrant said work against leaks and faulty or defective materials and workmanship for designated Warranty Period,
- C. NOW THEREFORE Roofing Installer hereby warrants, subject to terms and conditions herein set forth, that during Warranty Period he will, at his own cost and expense, make or cause to be made such repairs to or replacements of said work as are necessary to correct faulty and defective work and as are necessary to maintain said work in a watertight condition.
- D. This Warranty is made subject to the following terms and conditions:
 - 1. Specifically excluded from this Warranty are damages to work and other parts of the building, and to building contents, caused by:
 - a. Lightning;
 - b. Peak gust wind speed exceeding 74 mph;

- c. Fire;
 - d. Failure of roofing system substrate, including cracking, settlement, excessive deflection, deterioration, and decomposition;
 - e. Faulty construction of parapet walls, copings, chimneys, skylights, vents, equipment supports, and other edge conditions and penetrations of the work;
 - f. Vapor condensation on bottom of roofing; and
 - g. Activity on roofing by others, including construction contractors, maintenance personnel, other persons, and animals, whether authorized or unauthorized by Owner.
2. When work has been damaged by any of foregoing causes, Warranty shall be null and void until such damage has been repaired by Roofing Installer and until cost and expense thereof have been paid by Owner or by another responsible party so designated.
 3. Roofing Installer is responsible for damage to work covered by this Warranty but is not liable for consequential damages to building or building contents resulting from leaks or faults or defects of work.
 4. During Warranty Period, if Owner allows alteration of work by anyone other than Roofing Installer, including cutting, patching, and maintenance in connection with penetrations, attachment of other work, and positioning of anything on roof, this Warranty shall become null and void on date of said alterations, but only to the extent said alterations affect work covered by this Warranty. If Owner engages Roofing Installer to perform said alterations, Warranty shall not become null and void unless Roofing Installer, before starting said work, shall have notified Owner in writing, showing reasonable cause for claim, that said alterations would likely damage or deteriorate work, thereby reasonably justifying a limitation or termination of this Warranty.
 5. During Warranty Period, if original use of roof is changed and it becomes used for, but was not originally specified for, a promenade, work deck, spray-cooled surface, flooded basin, or other use or service more severe than originally specified, this Warranty shall become null and void on date of said change, but only to the extent said change affects work covered by this Warranty.
 6. Owner shall promptly notify Roofing Installer of observed, known, or suspected leaks, defects, or deterioration and shall afford reasonable opportunity for Roofing Installer to inspect work and to examine evidence of such leaks, defects, or deterioration.
 7. This Warranty is recognized to be the only warranty of Roofing Installer on said work and shall not operate to restrict or cut off Owner from other remedies and resources lawfully available to Owner in cases of roofing failure. Specifically, this Warranty shall not operate to relieve Roofing Installer of responsibility for performance of original work according to requirements of the Contract Documents, regardless of whether Contract was a contract directly with Owner or a subcontract with Owner's General Contractor.

E. IN WITNESS THEREOF, this instrument has been duly executed this _____ day of _____, 2021.

1. Authorized Signature: _____
2. Name: _____

END OF SECTION 07591

SECTION 07620 - SHEET METAL FLASHING AND TRIM

PART 1 - GENERAL

1.1 RELATED DOCUMENTS

- A. Drawings and general provisions of the Contract, including General and Supplementary Conditions and Division 1 Specification Sections, apply to this Section.

1.2 SUMMARY

- A. This Section includes the following sheet metal flashing and trim:
 - 1. Manufactured reglets.
 - 2. Formed low-slope roof flashing and trim.
 - 3. Formed wall flashing and trim.
 - 4. Formed equipment support flashing.
- B. Related Sections include the following:
 - 1. Division 1 Section "Summary for installing sheet metal flashing and trim."
 - 2. Division 6 Section "Miscellaneous Carpentry" for wood nailers, curbs, and blocking.
 - 3. Division 7 Section "Hot Applied Built-Up Roofing" for installing sheet metal flashing and trim integral with roofing membrane.

1.3 PERFORMANCE REQUIREMENTS

- A. Water Infiltration: Provide sheet metal flashing and trim that do not allow water infiltration to building interior.

1.4 SUBMITTALS

- A. Shop Drawings: Show layouts of sheet metal flashing and trim, including plans and elevations. Distinguish between shop- and field-assembled work. Include the following:
 - 1. Identify material, thickness, weight, and finish for each item and location in Project.
 - 2. Details for forming sheet metal flashing and trim, including profiles, shapes, seams, and dimensions.
 - 3. Details for fastening, joining, supporting, and anchoring sheet metal flashing and trim, including fasteners, clips, cleats, and attachments to adjoining work.
 - 4. Details of expansion-joint covers, including showing direction of expansion and contraction.
- B. Samples for Initial Selection: For each type of sheet metal flashing and trim indicated with factory-applied color finishes.
 - 1. Include similar Samples of trim and accessories involving color selection.

1.5 QUALITY ASSURANCE

- A. Sheet Metal Flashing and Trim Standard: Comply with SMACNA's "Architectural Sheet Metal Manual." Conform to dimensions and profiles shown unless more stringent requirements are indicated.
- B. Preinstallation Conference: Conduct conference at Project site to comply with requirements in Division 1 Section "Project Management and Coordination."
 - 1. Meet with Owner, Manufacturer, Owner's insurer if applicable, Installer, and installers whose work interfaces with or affects sheet metal flashing and trim including installers of roofing materials, roof accessories, unit skylights, and roof-mounted equipment.
 - 2. Review methods and procedures related to sheet metal flashing and trim.
 - 3. Examine substrate conditions for compliance with requirements, including flatness and attachment to structural members.
 - 4. Document proceedings, including corrective measures and actions required, and furnish copy of record to each participant.

1.6 DELIVERY, STORAGE, AND HANDLING

- A. Deliver sheet metal flashing materials and fabrications undamaged. Protect sheet metal flashing and trim materials and fabrications during transportation and handling.
- B. Unload, store, and install sheet metal flashing materials and fabrications in a manner to prevent bending, warping, twisting, and surface damage.
- C. Stack materials on platforms or pallets, covered with suitable weathertight and ventilated covering. Do not store sheet metal flashing and trim materials in contact with other materials that might cause staining, denting, or other surface damage.

1.7 COORDINATION

- A. Coordinate installation of sheet metal flashing and trim with interfacing and adjoining construction to provide a leakproof, secure, and noncorrosive installation.
- B. Coordinate all sheet metal flashing and trim with roofing material manufacturer who will be warranting roof system, which will include sheet metal flashing and trim.

PART 2 - PRODUCTS

2.1 MANUFACTURERS

- A. In other Part 2 articles where titles below introduce lists, the following requirements apply to product selection:
 - 1. Available Products: Subject to compliance with requirements, products that may be incorporated into the Work include, but are not limited to, products specified.

2. Available Manufacturers: Subject to compliance with requirements, manufacturers offering products that may be incorporated into the Work include, but are not limited to, manufacturers specified.

2.2 SHEET METALS

1. Fluoropolymer 2-Coat System: Manufacturer's standard 2-coat, thermocured system consisting of specially formulated inhibitive primer and fluoropolymer color topcoat containing not less than 70 percent polyvinylidene fluoride resin by weight; complying with AAMA 2604.

- 1) Color: As indicated by manufacturer's designations.

2.3 UNDERLAYMENT MATERIALS

- A. Felts: 40 mil self-adhered air and vapor control membrane consisting of a self-adhering SBS rubberized asphalt laminated to a slip resistant, cross laminated polyethylene surface film..

2.4 MISCELLANEOUS MATERIALS

- A. General: Provide materials and types of fasteners, solder, welding rods, protective coatings, separators, sealants, and other miscellaneous items as required for complete sheet metal flashing and trim installation.
- B. Fasteners: Wood screws, annular threaded nails, self-tapping screws, self-locking rivets and bolts, and other suitable fasteners designed to withstand design loads.
 1. Exposed Fasteners: Heads matching color of sheet metal by means of plastic caps or factory-applied coating.
 2. Fasteners for Flashing and Trim: Blind fasteners or self-drilling screws, gasketed, with hex washer head.
 3. Blind Fasteners: High-strength aluminum or stainless-steel rivets.
- C. Solder for Lead: ASTM B 32, Grade Sn50, 50 percent tin and 50 percent lead.
- D. Butyl Sealant: ASTM C 1311, single-component, solvent-release butyl rubber sealant, polyisobutylene plasticized, heavy bodied for hooked-type expansion joints with limited movement.
- E. Asphalt Roofing Cement: ASTM D 4586, asbestos free, of consistency required for application.

2.5 FABRICATION, GENERAL

- A. General: Custom fabricate sheet metal flashing and trim to comply with recommendations in SMACNA's "Architectural Sheet Metal Manual" that apply to design, dimensions, metal, and other characteristics of item indicated. Shop fabricate items where practicable. Obtain field measurements for accurate fit before shop fabrication.

- B. Fabricate sheet metal flashing and trim in thickness or weight needed to comply with performance requirements, but not less than that specified for each application and metal.
- C. Fabricate sheet metal flashing and trim without excessive oil canning, buckling, and tool marks and true to line and levels indicated, with exposed edges folded back to form hems.
 - 1. Seams for Other Than Aluminum: Fabricate nonmoving seams in accessories with flat-lock seams. Tin edges to be seamed, form seams, and solder.
- D. Sealed Joints: Form nonexpansion but movable joints in metal to accommodate elastomeric sealant to comply with SMACNA recommendations.
- E. Expansion Provisions: Where lapped or bayonet-type expansion provisions in the Work cannot be used, form expansion joints of intermeshing hooked flanges, not less than 1 inch (25 mm) deep, filled with elastomeric sealant concealed within joints.
- F. Conceal fasteners and expansion provisions where possible on exposed-to-view sheet metal flashing and trim, unless otherwise indicated.
- G. Fabricate cleats and attachment devices from same material as accessory being anchored or from compatible, noncorrosive metal.
 - 1. Thickness: As recommended by SMACNA's "Architectural Sheet Metal Manual" for application but not less than thickness of metal being secured.

2.6 LOW-SLOPE ROOF SHEET METAL FABRICATIONS

- A. Roof Edge Flashing, Gravel Stop, and Fascia Caps: Fabricate in minimum 96-inch long, but not exceeding 10-foot long, sections. Furnish with 6-inch wide joint cover plates.
 - 1. Joint Style: Lap, 4 inches (100 mm) wide.
 - a. Prepainted, Coated Steel: 24-gauge.
- B. Copings and Raised Edge Caps: Fabricate in minimum 96-inch long, but not exceeding 10-foot long, sections. Fabricate joint plates of same thickness as copings. Furnish with continuous cleats to support edge of external leg and drill elongated holes for fasteners on interior leg. Miter corners, seal, and solder or weld watertight.
 - 1. Joint Style: Butt, with 12-inch- (300-mm-) wide concealed backup plate and 6-inch- (150-mm-) wide exposed cover plates.
 - 2. Fabricate copings from the following material:
 - a. Prepainted, Coated Steel: 24-gauge.
- C. Roof to Wall Transition, Roof to Sheet Metal, Roof Edging Transition, Expansion-Joint Cover: Fabricate from the following material:
 - 1. Prepainted, Metallic-Coated Steel: 0.0276 inch (0.70 mm) thick.
- D. Counterflashing: Fabricate from the following material:
 - 1. Prepainted, Coated Steel: 24-gauge.
- E. Flashing Receivers: Fabricate from the following material:

1. Prepainted, Coated Steel: 24-gauge
- F. Roof-Penetration Flashing: Fabricate from the following material:
 1. Galvanized Steel: 22-gauge.
- G. Roof-Drain Flashing: Fabricate from the following material:
 1. Lead: 4.0-lb/sq. ft. (1.6 mm thick), hard tempered.

2.7 WALL SHEET METAL FABRICATIONS

- A. Wall Expansion-Joint Cover: Fabricate from the following material:
 1. Prepainted, Coated Steel: 24-gauge

2.8 MISCELLANEOUS SHEET METAL FABRICATIONS

- A. Equipment Support Flashing: Fabricate from the following material:
 1. Prepainted, Coated Steel: 2-gauge.

PART 3 - EXECUTION

3.1 EXAMINATION

- A. Examine substrates, areas, and conditions, with Installer present, to verify actual locations, dimensions and other conditions affecting performance of work.
 1. Verify that substrate is sound, dry, smooth, clean, sloped for drainage, and securely anchored.
 2. Proceed with installation only after unsatisfactory conditions have been corrected.

3.2 INSTALLATION, GENERAL

- A. General: Anchor sheet metal flashing and trim and other components of the Work securely in place, with provisions for thermal and structural movement. Use fasteners, solder, welding rods, protective coatings, separators, sealants, and other miscellaneous items as required to complete sheet metal flashing and trim system.
 1. Torch cutting of sheet metal flashing and trim is not permitted.
- B. Install exposed sheet metal flashing and trim without excessive oil canning, buckling, and tool marks.
- C. Install sheet metal flashing and trim true to line and levels indicated. Provide uniform, neat seams with minimum exposure of solder, welds, and butyl sealant.
- D. Install sheet metal flashing and trim to fit substrates and to result in watertight performance. Verify shapes and dimensions of surfaces to be covered before fabricating sheet metal.

1. Space cleats not more than 12 inches (300 mm) apart. Anchor each cleat with two fasteners. Bend tabs over fasteners.
- E. Expansion Provisions: Provide for thermal expansion of exposed flashing and trim. Space movement joints at a maximum of 10 feet (3 m) with no joints allowed within 24 inches (600 mm) of corner or intersection. Where lapped or bayonet-type expansion provisions cannot be used or would not be sufficiently watertight, form expansion joints of intermeshing hooked flanges, not less than 1 inch (25 mm) deep, filled with butyl sealant concealed within joints.
- F. Fasteners: Use fasteners of sizes that will penetrate substrate not less than 1-1/4 inches (32 mm) for nails and not less than 3/4 inch (19 mm) for wood screws.
 1. Galvanized or Prepainted, Metallic-Coated Steel: Use stainless-steel fasteners.
 2. Aluminum: Use aluminum or stainless-steel fasteners.
 3. Copper Use copper or stainless-steel fasteners.
 4. Stainless Steel: Use stainless-steel fasteners.
- G. Seal joints with butyl sealant as required for watertight construction.
 1. Where sealant-filled joints are used, embed hooked flanges of joint members not less than 1 inch (25 mm) into sealant. Form joints to completely conceal sealant. When ambient temperature at time of installation is moderate, between 40 and 70 deg F (4 and 21 deg C), set joint members for 50 percent movement either way. Adjust setting proportionately for installation at higher ambient temperatures. Do not install sealant-type joints at temperatures below 40 deg F (4 deg C).
 2. Prepare joints and apply sealants to comply with requirements in Division 7 Section "Joint Sealants."
- H. Soldered Joints: Clean surfaces to be soldered, removing oils and foreign matter. Pre-tin edges of sheets to be soldered to a width of 1-1/2 inches (38 mm) except where pre-tinned surface would show in finished Work.
 1. Do not solder prepainted and metallic-coated steel sheet.
 2. Where surfaces to be soldered are lead coated, do not tin edges, but wire brush lead coating before soldering.
 3. Lead-Coated Copper Soldering: Wire brush edges of sheets before soldering.
 4. Do not use open-flame torches for soldering. Heat surfaces to receive solder and flow solder into joints. Fill joints completely. Completely remove flux and spatter from exposed surfaces.

3.3 ROOF DRAINAGE SYSTEM INSTALLATION

- A. General: Install sheet metal roof drainage items to produce complete roof drainage system according to SMACNA recommendations and as indicated. Coordinate installation of roof perimeter flashing with installation of roof drainage system.

3.4 ROOF FLASHING INSTALLATION

- A. General: Install sheet metal roof flashing and trim to comply with performance requirements, sheet metal manufacturer's written installation instructions, and SMACNA's "Architectural Sheet Metal Manual." Provide concealed fasteners where possible, set units true to line, and level as indicated. Install work with laps, joints, and seams that will be permanently watertight.
- B. Copings and Raised Edge Caps: Anchor to resist uplift and outward forces according to recommendations in FMG Loss Prevention Data Sheet 1-49 for specified wind zone and as indicated.
 - 1. Interlock exterior bottom edge of coping with continuous cleats anchored to substrate at 16-inch (400-mm) centers.
 - 2. Anchor interior leg of coping with screw fasteners and washers at 18-inch (450-mm) centers.
- C. Pipe or Post Counterflashing: Install counterflashing umbrella with close-fitting collar with top edge flared for butyl sealant, extending a minimum of 4 inches (100 mm) over base flashing. Install stainless-steel draw band and tighten.
- D. Counterflashing: Coordinate installation of counterflashing with installation of base flashing. Insert counterflashing in reglets or receivers and fit tightly to base flashing. Extend counterflashing 4 inches (100 mm) over base flashing. Lap counterflashing joints a minimum of 4 inches (100 mm) and bed with butyl sealant.
 - 1. Secure in a waterproof manner by means of snap-in installation and sealant or lead wedges and sealant.
- E. Roof-Penetration Flashing: Coordinate installation of roof-penetration flashing with installation of roofing and other items penetrating roof. Install flashing as follows:
 - 1. Turn lead flashing down inside vent piping, being careful not to block vent piping with flashing.
 - 2. Seal with butyl sealant and clamp flashing to pipes penetrating roof except for lead flashing on vent piping.

3.5 WALL FLASHING INSTALLATION

- A. General: Install sheet metal wall flashing to intercept and exclude penetrating moisture according to SMACNA recommendations and as indicated. Coordinate installation of wall flashing with installation of wall-opening components such as windows, doors, and louvers.
- B. Reglets: Installation of reglets into masonry joints as specified and approved by roofing material manufacturer.

3.6 MISCELLANEOUS FLASHING INSTALLATION

- A. Equipment Support Flashing: Coordinate installation of equipment support flashing with installation of roofing and equipment. Weld or seal flashing with butyl sealant to equipment support member.

3.7 CLEANING AND PROTECTION

- A. Clean exposed metal surfaces of substances that interfere with uniform oxidation and weathering.
- B. Clean and neutralize flux materials. Clean off excess solder and sealants.
- C. Remove temporary protective coverings and strippable films as sheet metal flashing and trim are installed. On completion of installation, clean finished surfaces, including removing unused fasteners, metal filings, pop rivet stems, and pieces of flashing. Maintain in a clean condition during construction.
- D. Replace sheet metal flashing and trim that have been damaged or that have deteriorated beyond successful repair by finish touchup or similar minor repair procedures.

END OF SECTION 07620

ROOF DIAGNOSTIC SURVEY FOR KANSAS CITY PUBLIC SCHOOLS

KANSAS CITY - KS 66102

DRAWINGS

TITLE PAGE

SHEET A	EARLY CHILDHOOD - MOISTURE SURVEY
SHEET B	EARLY CHILDHOOD - ROOF DATA, THERMOGRAMS & PHOTOS
SHEET C	SUMNER ACADEMY - MOISTURE SURVEY
SHEET D	SUMNER ACADEMY - ROOF DATA, THERMOGRAMS & PHOTOS

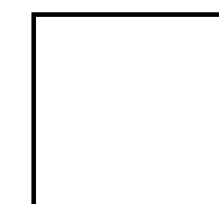

N
KANSAS CITY EARLY CHILDHOOD CENTER - ROOF PLAN
SCALE: NO SCALE

N
SUMNER ACADEMY OF ARTS & SCIENCE - ROOF PLAN
SCALE: NO SCALE

How An Infrared Survey Works:

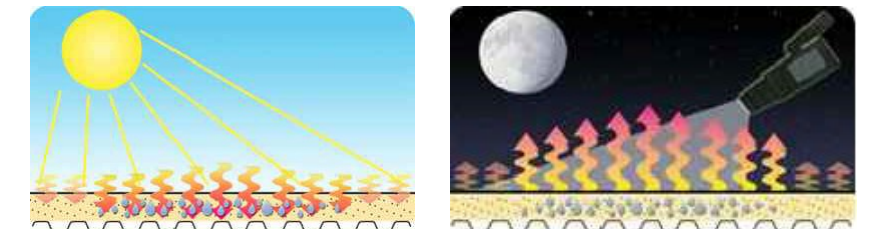

During the daytime, wet roof insulation absorbs more solar energy from the sun than dry roof insulation. During the nighttime, after the roof surface cools, the wet roof insulation will retain more solar energy than dry insulation and these temperature differences are detected by the infrared camera.

The wet roof areas are marked on the roof surface with visible paint markings. The wet roof areas are verified through core cuts and/or a Roof Moisture Meter.

How A Moisture Meter Works:

During the daytime, readings are taken and recorded in random locations and at wet areas found by the infrared camera.

Fast neutrons are emitted from the source in the Roof Moisture Meter into the roof system. The presence of hydrogen in the roof system slows the neutrons. These slowed neutrons as well as the fast neutrons are detected by the Roof Moisture Meter. A reading is displayed in the digital readout and gets recorded.

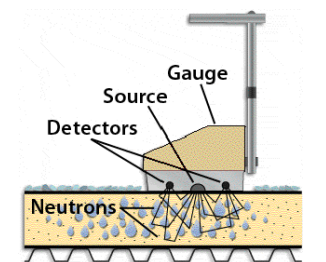

Core cuts are taken to determine a baseline for dry roof materials. Then wet roof areas are marked on the roof surface with visible paint markings.



Roofing & Building Maintenance

© 2021 BY TREMCO INCORPORATED. ALL RIGHTS RESERVED. NO PART OF THIS DOCUMENT MAY BE REPRODUCED OR TRANSMITTED IN ANY FORM OR BY ANY MEANS, ELECTRONIC, MECHANICAL, PHOTOCOPIING, RECORDING OR OTHERWISE WITHOUT THE EXPRESS PRIOR WRITTEN CONSENT OF TREMCO INCORPORATED. THE INFORMATION PROVIDED IN THIS DRAWING IS CURRENT AS OF THE DATE OF INSPECTION BY TREMCO INCORPORATED, WEATHERPROOFING TECHNOLOGIES, INC. OR THEIR DESIGNATED CONTRACTOR. ROOFING SYSTEM AND/OR BUILDING CONDITIONS CAN CHANGE AT ANY TIME, INCLUDING BUT NOT LIMITED TO THE AMOUNT OF WET INSULATION IN THE ROOFING SYSTEM, AND CAUSE THE INFORMATION PROVIDED IN THIS DRAWING TO CHANGE OR BECOME OUT OF DATE.
TREMCO'S INFRARED INSPECTIONS ARE PERFORMED BY CERTIFIED (EXPERIENCED) INFRARED THERMOGRAPHERS UTILIZING STATE-OF-THE-ART EQUIPMENT. ALL WORK CONFORMS WITH CURRENT INDUSTRY BEST PRACTICES, AND IS PERFORMED IN ACCORDANCE WITH STANDARDS PUBLISHED BY ASTM INTERNATIONAL AND INFRASPECTION INSTITUTE.

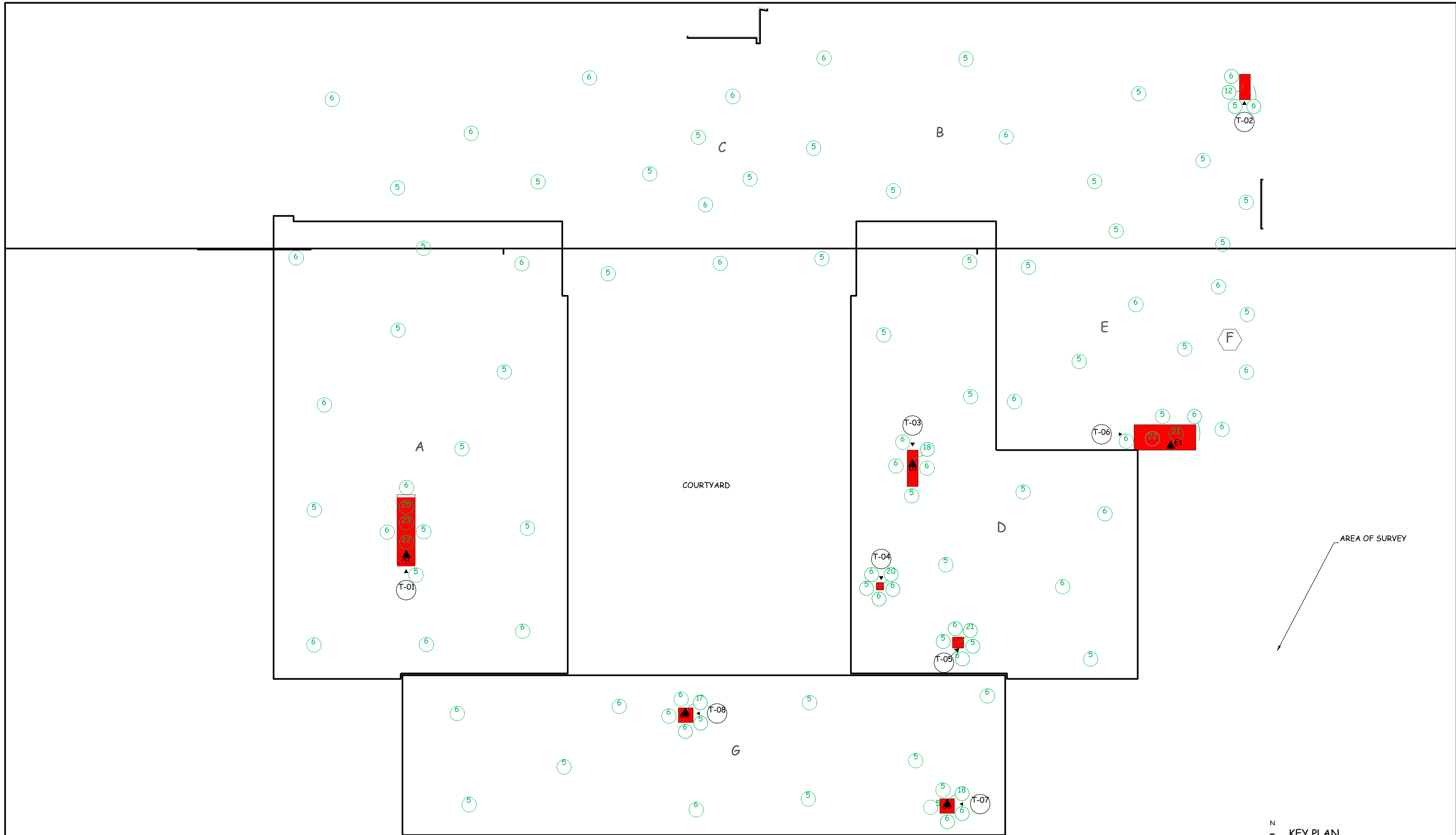

ROOF PLAN
SCALE: NO SCALE

KEY PLAN
SCALE: NO SCALE

- STANDARD KEY OF SYMBOLS
- # ROOF SECTION
 - ▲ DRY CORE
 - ▲ WET CORE
 - PHOTO
 - T-# THERMOGRAM
 - N.A.F. (NO ANOMALIES FOUND)
 - WET INSULATION
 - R.I.M. (RANDOM INTERMITTENT MOISTURE)
 - N.I.C. MOISTURE GRID
 - TRACE CORE
 - # MOISTURE READING



KANSAS CITY PUBLIC SCHOOLS
 KANSAS CITY EARLY CHILDHOOD CENTER
 1708 N 55TH ST
 KANSAS CITY, KS 66102

DIAGNOSTIC TECHNICIAN: CALER, C.R.C.	PROJECT NO.: #9688964
DRAWN BY: A.N.	SHEET NO.: A
DATE: 10/10/2021	

© 2021 BY TREMCO INCORPORATED. ALL RIGHTS RESERVED. NO PART OF THIS DOCUMENT MAY BE REPRODUCED OR TRANSMITTED IN ANY FORM OR BY ANY MEANS, ELECTRONIC, MECHANICAL, PHOTOCOPYING, RECORDING OR OTHERWISE WITHOUT THE EXPRESS PRIOR WRITTEN CONSENT OF TREMCO INCORPORATED. THE INFORMATION PROVIDED IN THIS DRAWING IS CURRENT AS OF THE DATE OF INSPECTION BY TREMCO INCORPORATED, WEATHERPROOFING TECHNOLOGIES, INC. OR THEIR DESIGNATED CONTRACTOR. ROOFING SYSTEM AND/OR BUILDING CONDITIONS CAN CHANGE AT ANY TIME, INCLUDING BUT NOT LIMITED TO THE AMOUNT OF WET INSULATION IN THE ROOFING SYSTEM, AND CAUSE THE INFORMATION PROVIDED IN THIS DRAWING TO CHANGE OR BECOME OUT OF DATE.

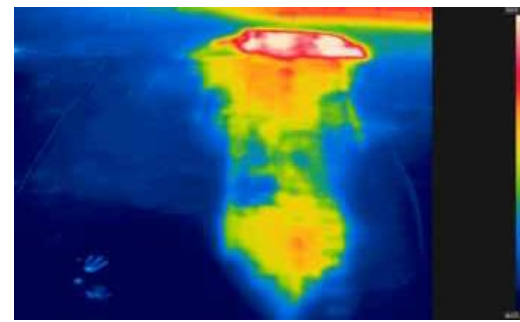

Thermogram T-01

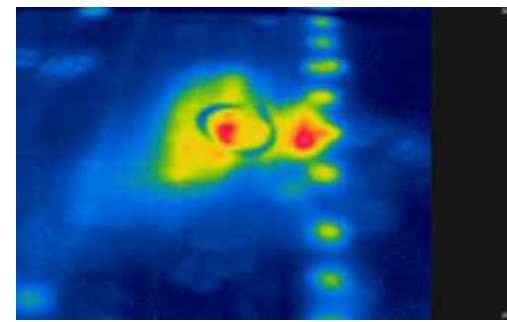

Thermogram T-07

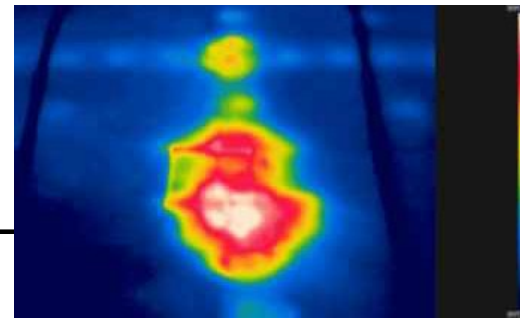

Thermogram T-02

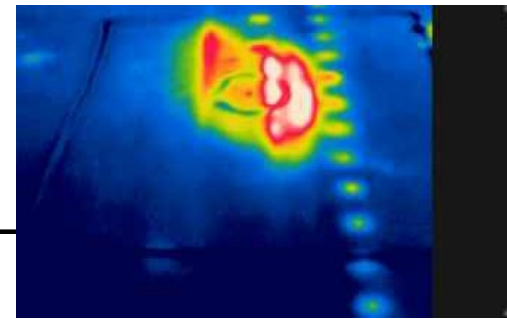

Thermogram T-08

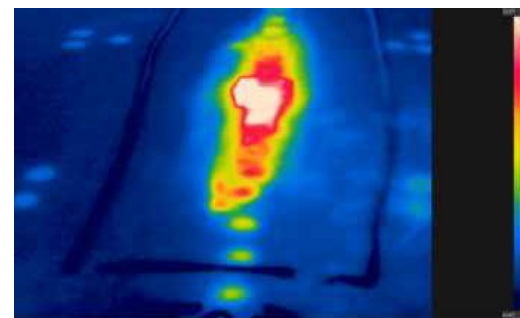

Thermogram T-03

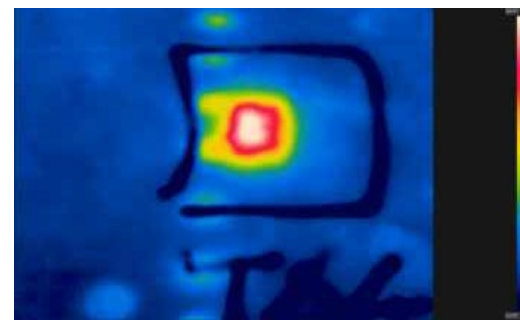

Thermogram T-04

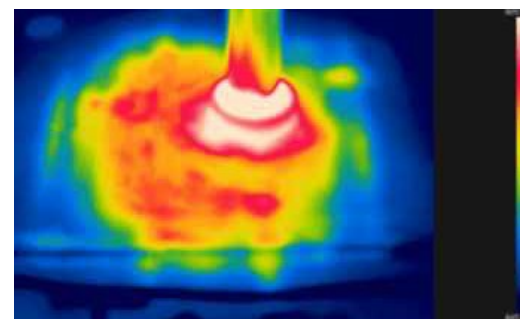

Thermogram T-05

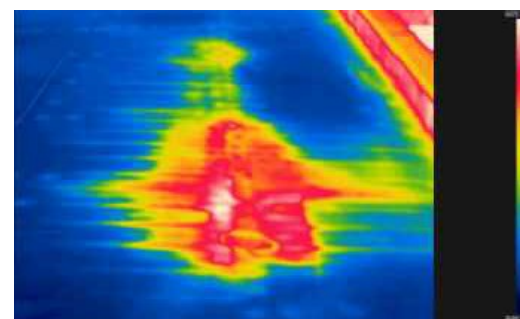

Thermogram T-06



CONSTRUCTION DATA					
ROOF SECTION	CORE CUT NUMBER	MOISTURE READING	MOISTURE PERCENTAGE	ROOF CONSTRUCTION	
A	A1	22	N/A	SINGLE-PLY (WHITE) ROOF SYSTEM	
			100%	2-1/2" POLYISOCYANURATE INSULATION	
			50%	2-1/2" POLYISOCYANURATE INSULATION	
			N/A	METAL DECK	
D	D1	18	N/A	SINGLE-PLY (WHITE) ROOF SYSTEM	
			100%	2-1/2" POLYISOCYANURATE INSULATION	
			30%	2-1/2" POLYISOCYANURATE INSULATION	
			N/A	METAL DECK	
E	E1	21	N/A	SINGLE-PLY (WHITE) ROOF SYSTEM	
			100%	2-1/2" POLYISOCYANURATE INSULATION	
			50%	2-1/2" POLYISOCYANURATE INSULATION	
			0%	FIBERGLASS INSULATION	
G	G1	18	N/A	SINGLE-PLY (WHITE) ROOF SYSTEM	
			100%	2-1/2" POLYISOCYANURATE INSULATION	
			30%	2-1/2" POLYISOCYANURATE INSULATION	
			N/A	METAL DECK	
G	G2	17	N/A	SINGLE-PLY (WHITE) ROOF SYSTEM	
			100%	2-1/2" POLYISOCYANURATE INSULATION	
			30%	2-1/2" POLYISOCYANURATE INSULATION	
			N/A	METAL DECK	

ROOF SECTION DATA			
ROOF SECTION	SIZE (S.F.)	WET (S.F.)	% WET
A	10,114	95	0.94%
B	13,058	21	0.16%
C	861	0	0.00%
D	7,402	43	0.58%
E	3,790	119	3.14%
F	1,008	0	0.00%
G	7,304	32	0.44%
TOTALS	43,537	310	0.71%

- STANDARD KEY OF SYMBOLS
- # ROOF SECTION
 - △ DRY CORE
 - ▲ WET CORE
 - P-# → PHOTO
 - T-# → THERMOGRAM
 - N.A.F. (NO ANOMALIES FOUND)
 - WET INSULATION
 - R.I.M. (RANDOM INTERMITTENT MOISTURE)
 - N.I.C.
 - MOISTURE GRID
 - TRACE CORE
 - # MOISTURE READING



KANSAS CITY PUBLIC SCHOOLS
 KANSAS CITY EARLY CHILDHOOD CENTER
 1708 N 55TH ST
 KANSAS CITY, KS 66102

DIAGNOSTIC TECHNICIAN: CALEB CRC	PROJECT NO: #9688964
DRAWN BY: A.N.	SHEET NO: B
DATE: 10/11/2021	

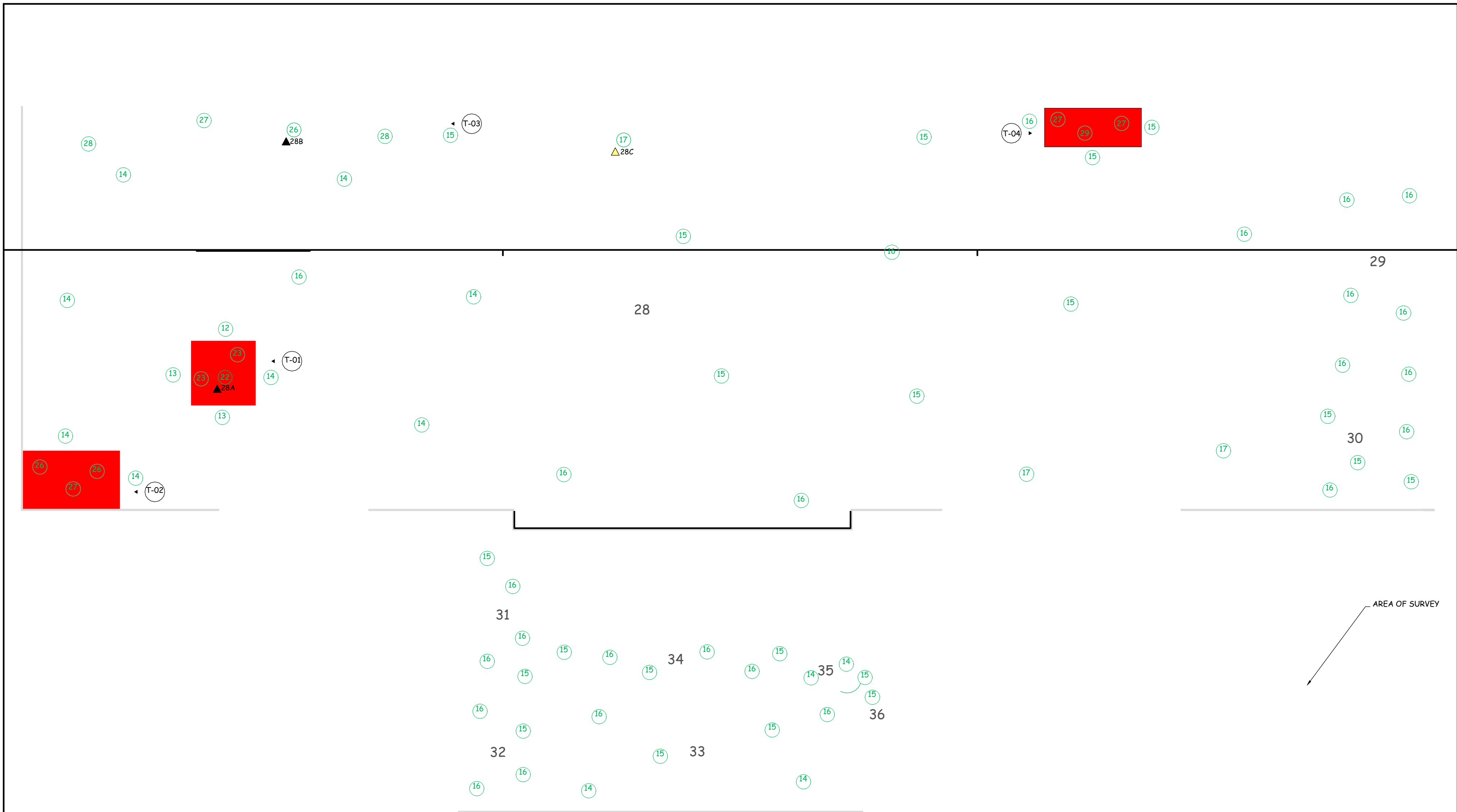

ROOF PLAN
SCALE: NO SCALE

KEY PLAN
SCALE: NO SCALE

- STANDARD KEY OF SYMBOLS
- # ROOF SECTION
 - ▲ DRY CORE
 - ▲ WET CORE
 - 📷 PHOTO
 - 📷 THERMOGRAM
 - N.A.F. (NO ANOMALIES FOUND)
 - WET INSULATION
 - R.I.M. (RANDOM INTERMITTENT MOISTURE)
 - N.I.C.
 - MOISTURE GRID
 - TRACE CORE
 - 🔍 MOISTURE READING



KANSAS CITY PUBLIC SCHOOLS
 SUMNER ACADEMY OF ARTS & SCIENCE
 1610 N 8TH ST
 KANSAS CITY, KS 66101

DIAGNOSTIC TECHNICIAN: CALER, C.C.	PROJECT NO: #9688964
DRAWN BY: A.N.	SHEET NO: C
DATE: 10/11/2021	

© 2021 BY TREMCO INCORPORATED. ALL RIGHTS RESERVED. NO PART OF THIS DOCUMENT MAY BE REPRODUCED OR TRANSMITTED IN ANY FORM OR BY ANY MEANS, ELECTRONIC, MECHANICAL, PHOTOCOPYING, RECORDING OR OTHERWISE WITHOUT THE EXPRESS PRIOR WRITTEN CONSENT OF TREMCO INCORPORATED. THE INFORMATION PROVIDED IN THIS DRAWING IS CURRENT AS OF THE DATE OF INSPECTION BY TREMCO INCORPORATED, WEATHERPROOFING TECHNOLOGIES, INC. OR THEIR DESIGNATED CONTRACTOR. ROOFING SYSTEM AND/OR BUILDING CONDITIONS CAN CHANGE AT ANY TIME, INCLUDING BUT NOT LIMITED TO THE AMOUNT OF WET INSULATION IN THE ROOFING SYSTEM, AND CAUSE THE INFORMATION PROVIDED IN THIS DRAWING TO CHANGE OR BECOME OUT OF DATE.

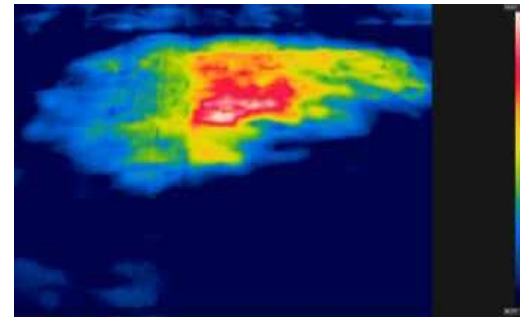

Thermogram T-01

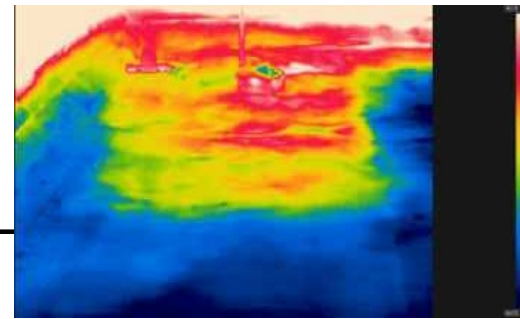

Thermogram T-02

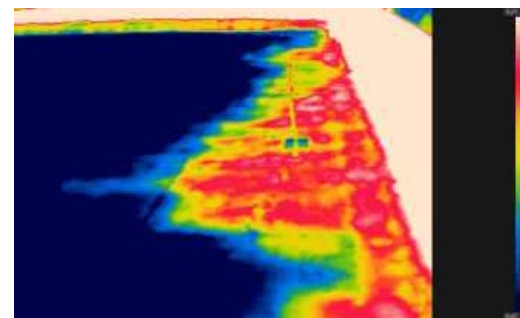

Thermogram T-03

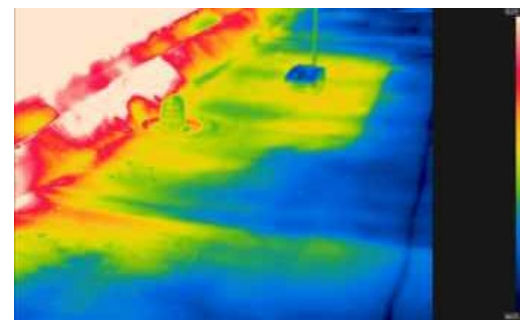

Thermogram T-04



CONSTRUCTION DATA				
ROOF SECTION	CORE CUT NUMBER	MOISTURE READING	MOISTURE PERCENTAGE	ROOF CONSTRUCTION
28	28A	22	N/A	MODIFIED BITUMEN BUILT UP ROOF
			100%	1/2" WOODFIBER INSULATION
			N/A	CONCRETE DECK
28	28B	26	N/A	MODIFIED BITUMEN BUILT UP ROOF
			100%	1/2" WOODFIBER INSULATION
			N/A	CONCRETE DECK
28	28C	17	N/A	MODIFIED BITUMEN BUILT UP ROOF
			0%	1/2" WOODFIBER INSULATION
			N/A	CONCRETE DECK

ROOF SECTION DATA			
ROOF SECTION	SIZE (S.F.)	WET (S.F.)	% WET
28	12,279	837	6.82%
29	560	0	0.00%
30	360	0	0.00%
31	240	0	0.00%
32	216	0	0.00%
33	900	0	0.00%
34	320	0	0.00%
35	40	0	0.00%
36	40	0	0.00%
TOTALS	14,955	837	5.60%

STANDARD KEY OF SYMBOLS

# ROOF SECTION	P-# PHOTO	WET INSULATION	N.I.C.
▲ DRY CORE	T-# THERMOGRAM	R.I.M. (RANDOM INTERMITTENT MOISTURE)	MOISTURE GRID
▲ WET CORE	N.A.F. (NO ANOMALIES FOUND)		TRACE CORE
			# MOISTURE READING



KANSAS CITY PUBLIC SCHOOLS
 SUMNER ACADEMY OF ARTS & SCIENCE
 1610 N 8TH ST
 KANSAS CITY, KS 66101

DIAGNOSTIC TECHNICIAN: CALEB CRC	PROJECT NO: #9688964
DRAWN BY: A.N.	SHEET NO: D
DATE: 10/10/2021	

Argentine Middle School
2123 Ruby Avenue, Kansas City, KS 66106

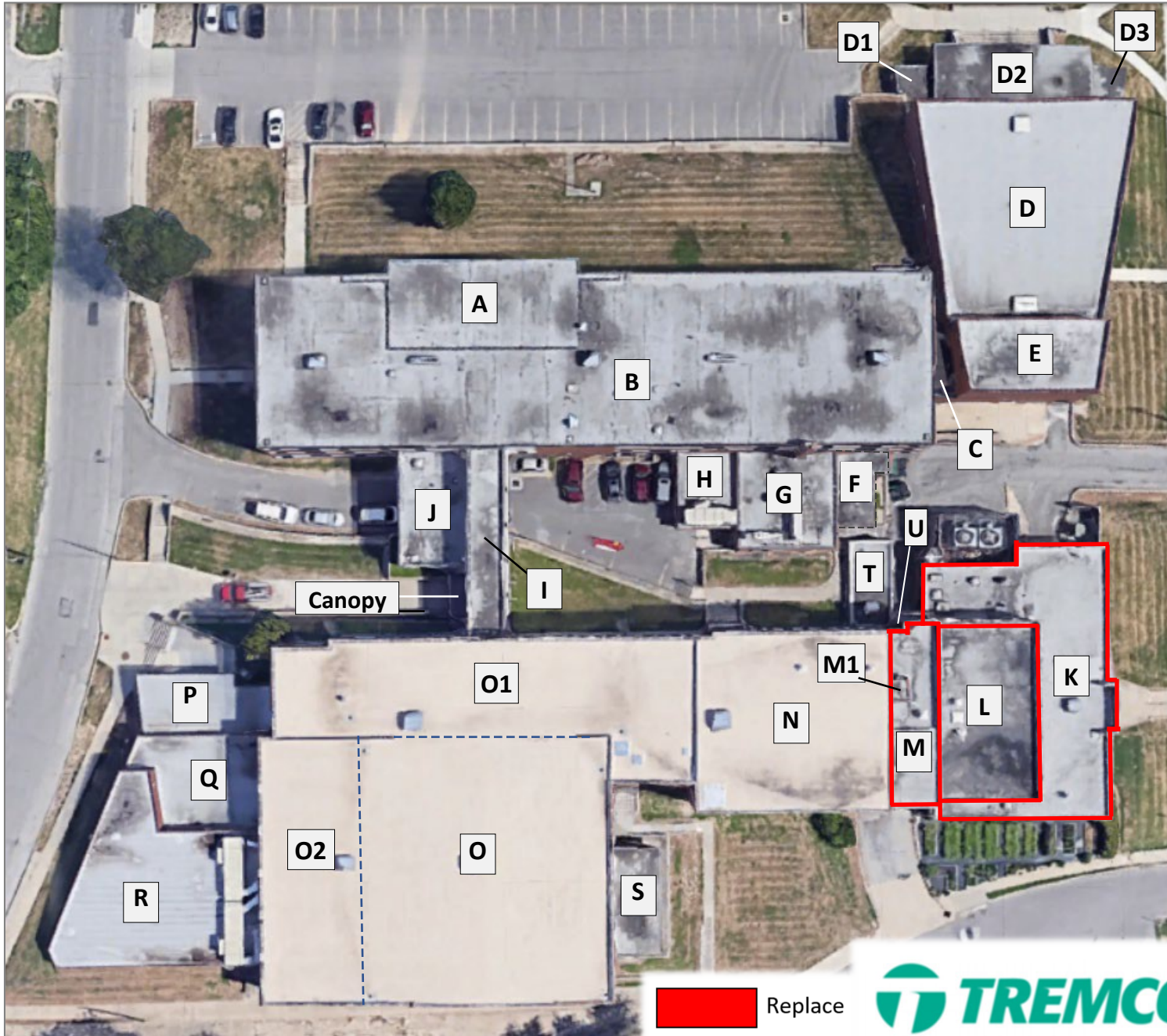

J.C. Harmon High School
2400 Steele Road, Kansas City, KS 66106



KCK Early Childhood Center
1708 N. 55th Street, Kansas City, KS 66201

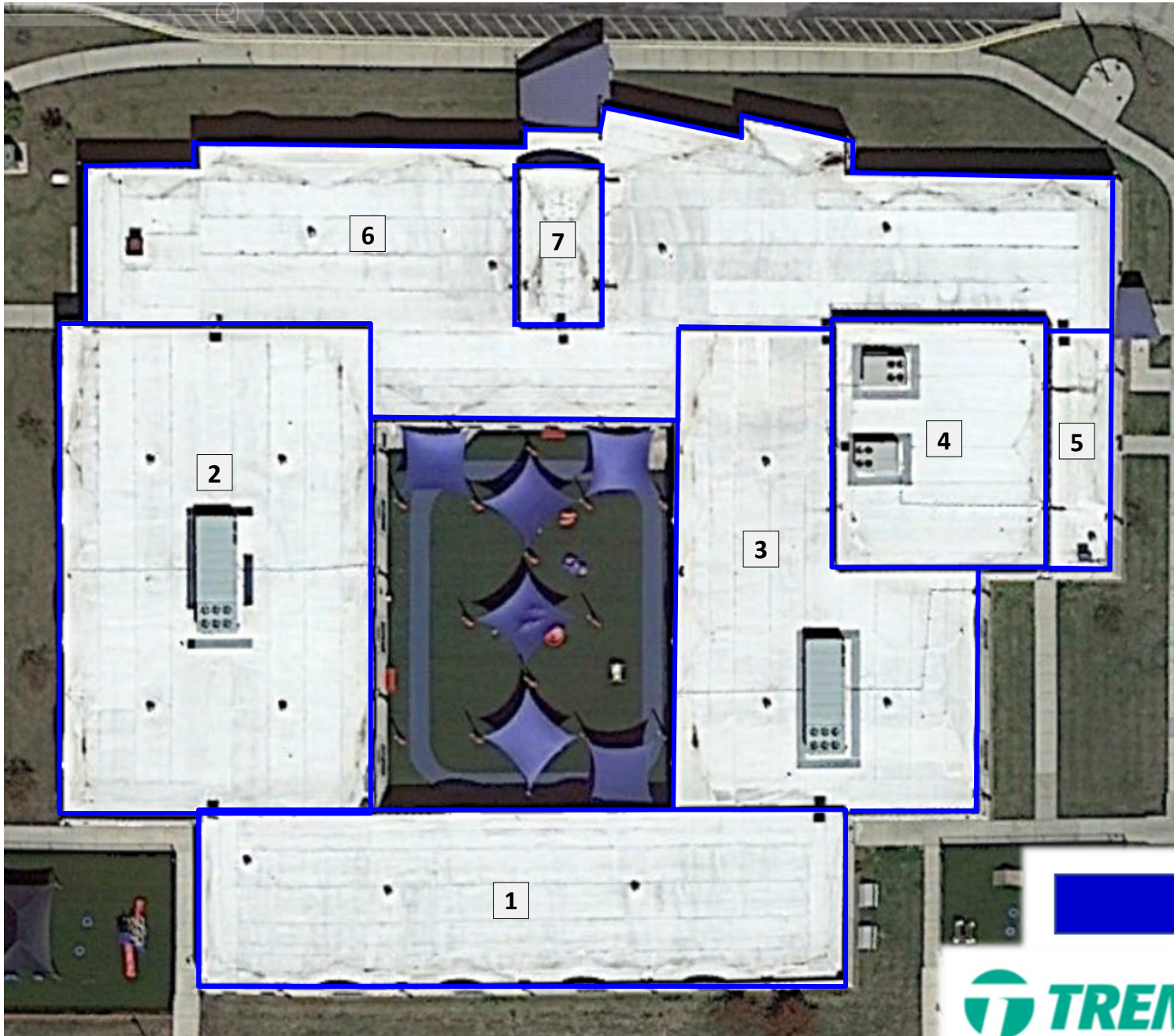

NCO - North Central Office

2212 N. 59th Street, Kansas City, KS 66104



 Restore
(in 1-3 Years)

 Replace



New Stanley Elementary
3604 Metropolitan Avenue, Kansas City, KS 66106



 Replace

Sumner Academy

1610 N. 8th Street, Kansas City, KS 66101

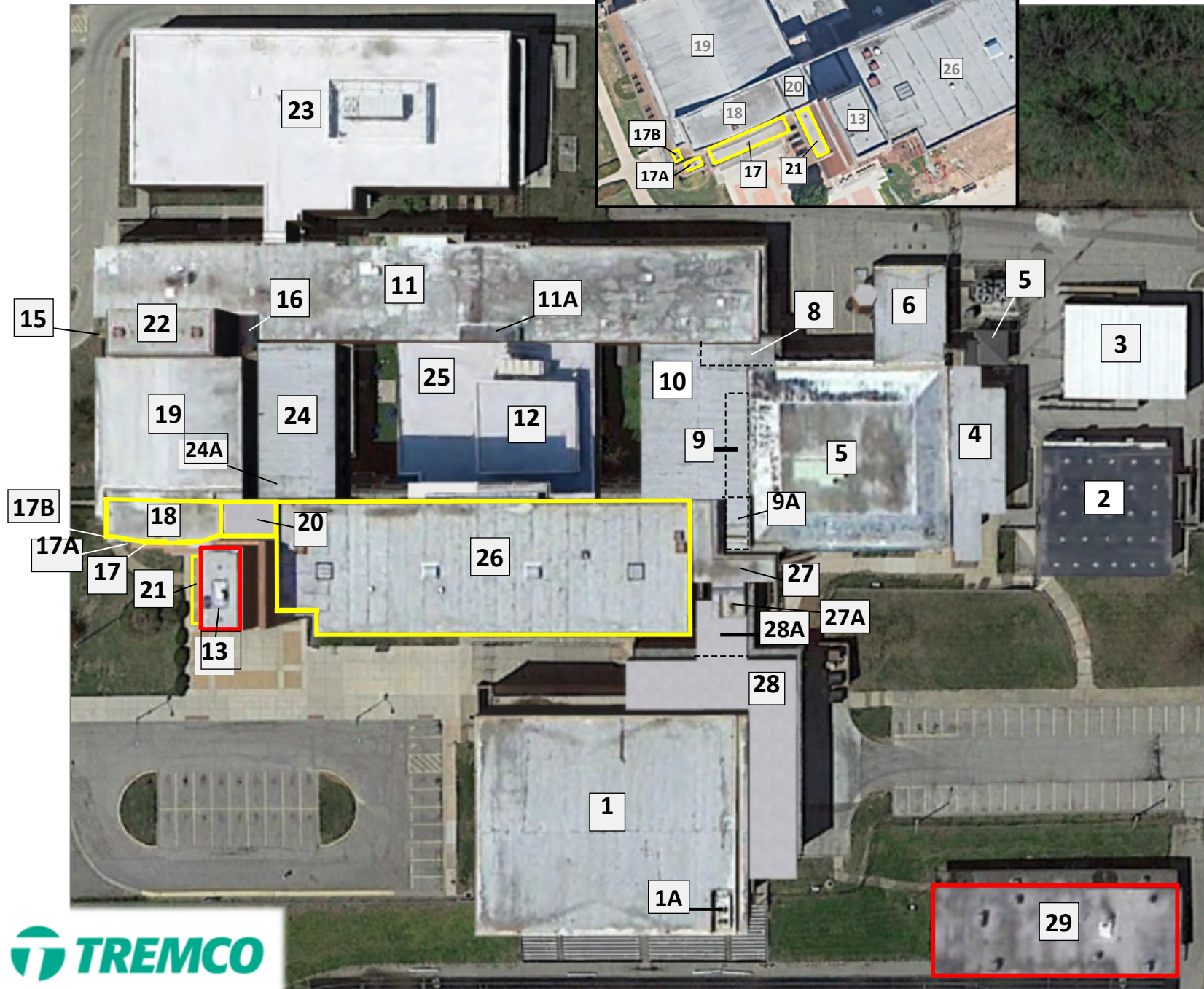

Washington High School

7340 Leavenworth Road, Kansas City, KS 66109

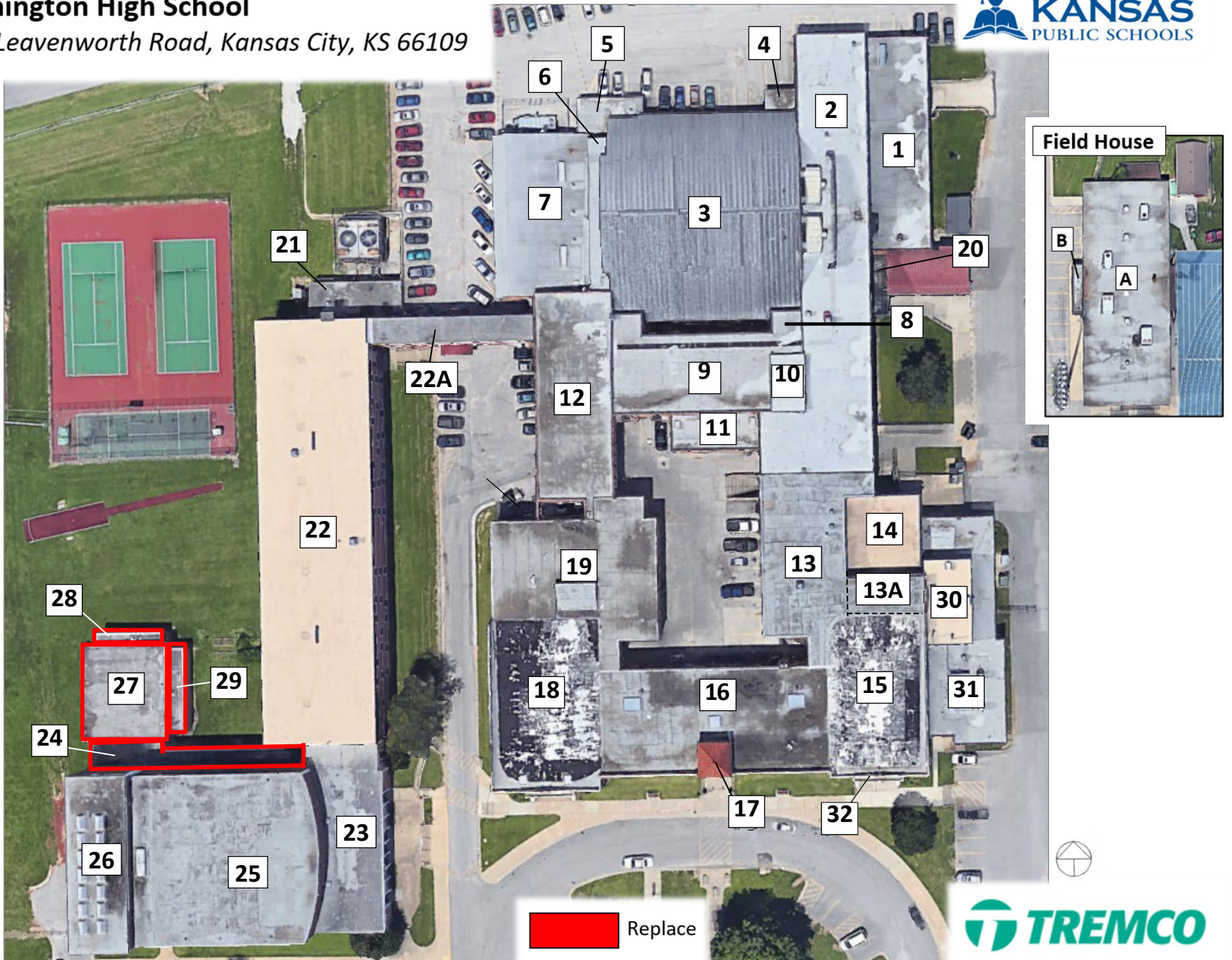

Wyandotte High School

2501 Minnesota Avenue, Kansas City, KS 66102

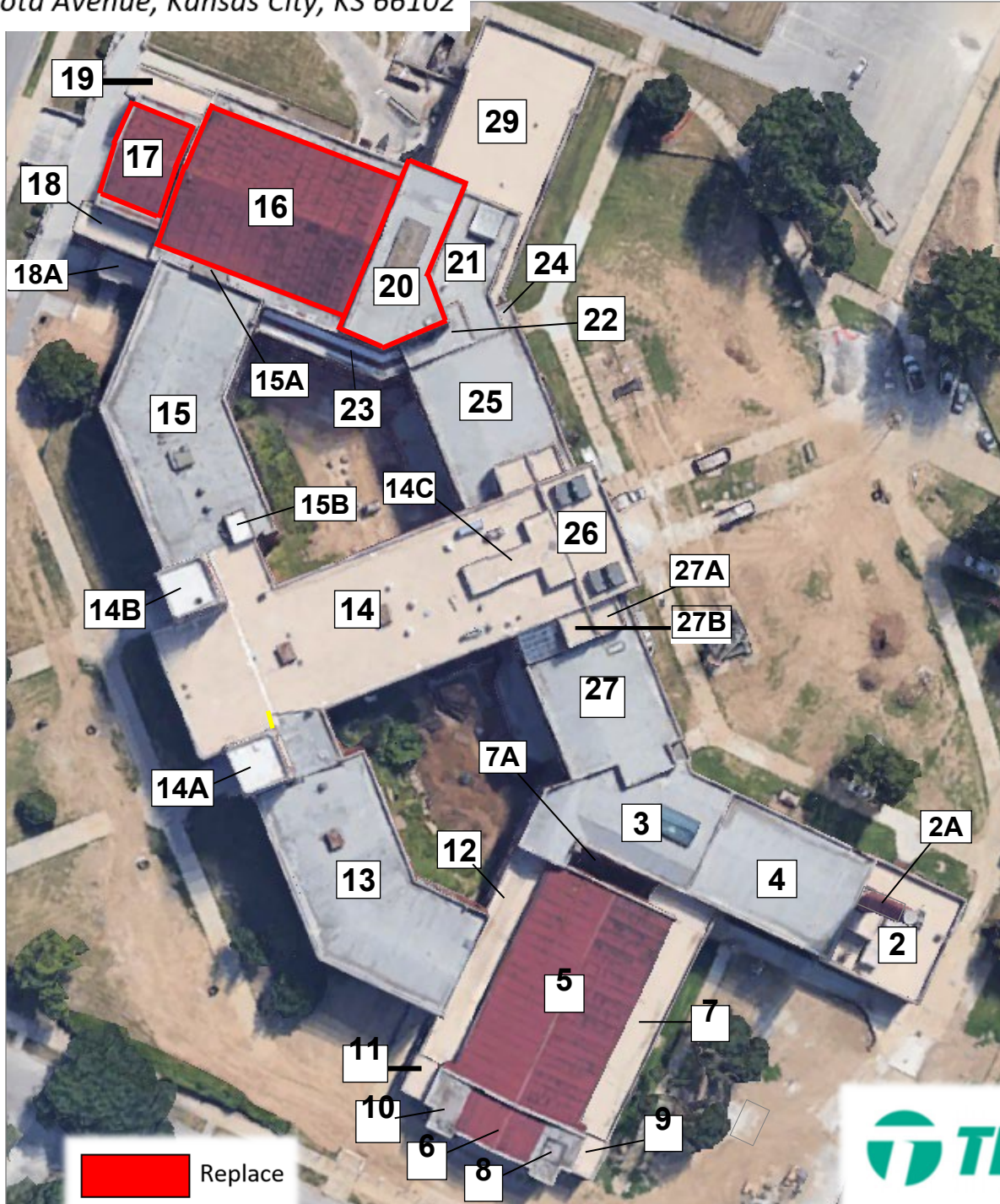

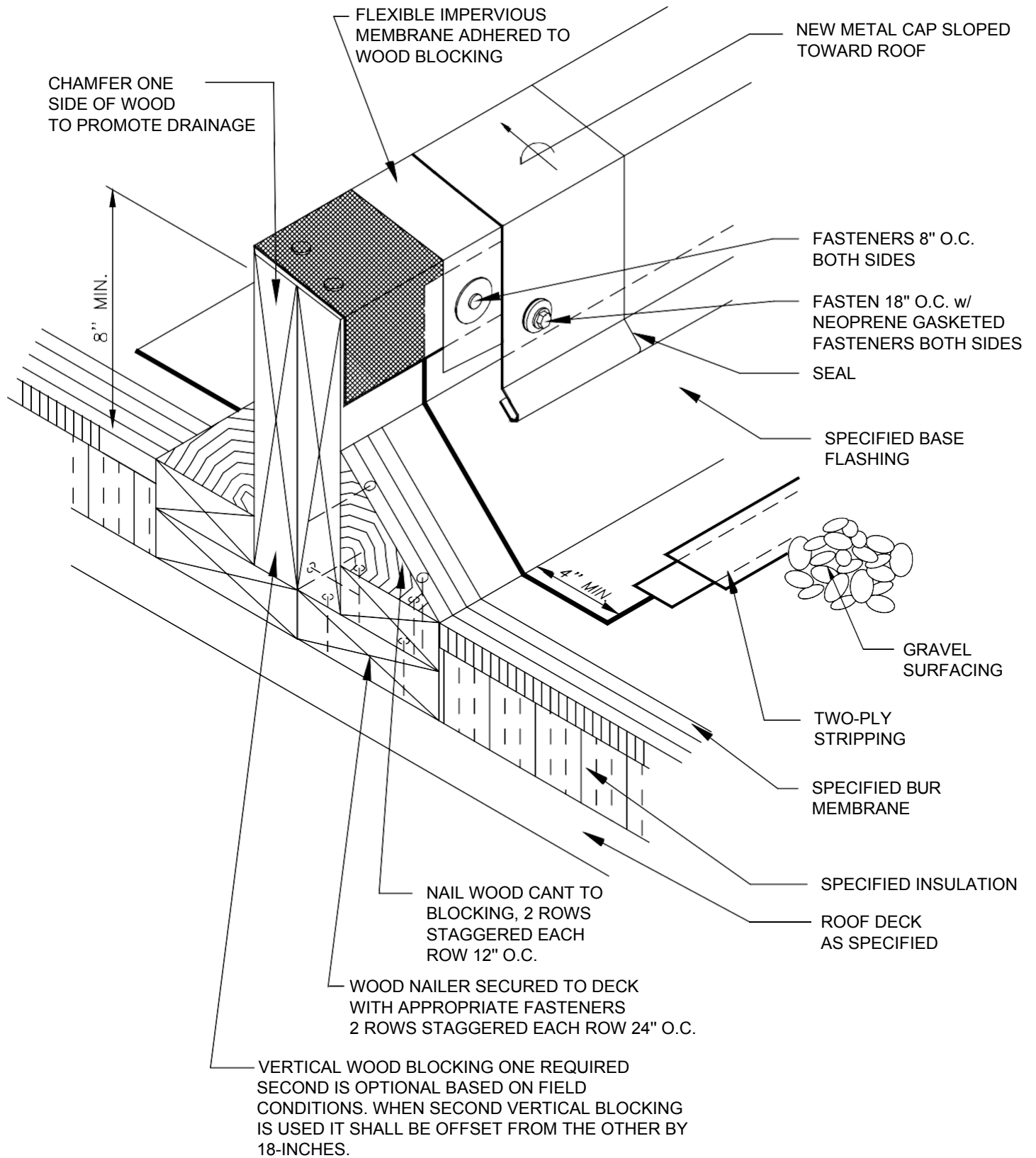

BUILT-UP ROOFING
HOT/COLD BASE FLASHING AREA DIVIDER

DWG NO. 01

N.T.S.



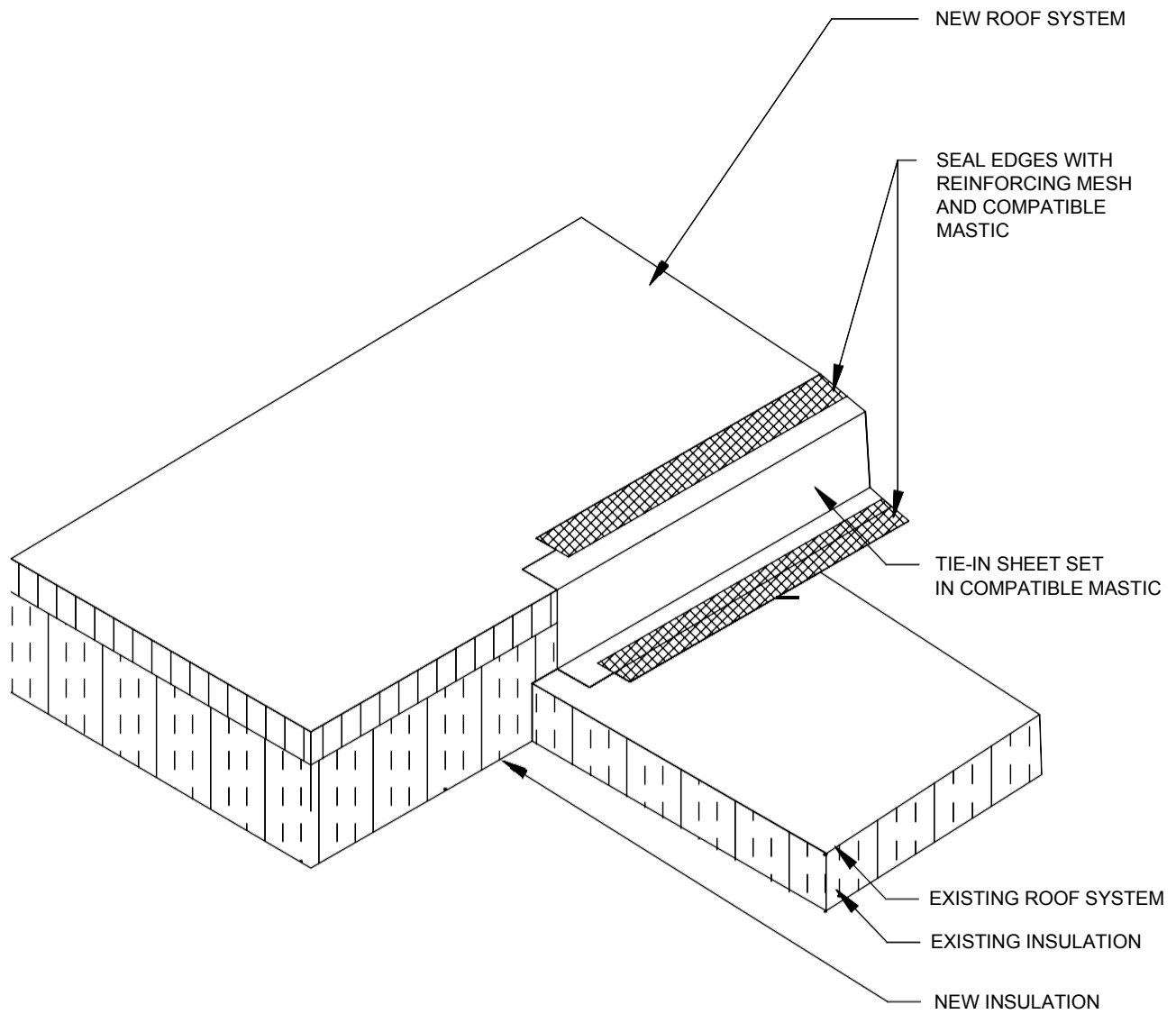

NOTES

1. BEFORE NEXT DAY'S WORK, REMOVE TEMPORARY TIE-IN AND INSULATION FILLERS
2. EXTEND TIE-IN SHEET MINIMUM OF 6-INCHES ONTO BOTH SURFACES

ASPHALTIC ROOFING SYSTEMS
 DAILY WATERSTOP / TIE-IN
 DWG NO. 30A

N.T.S.



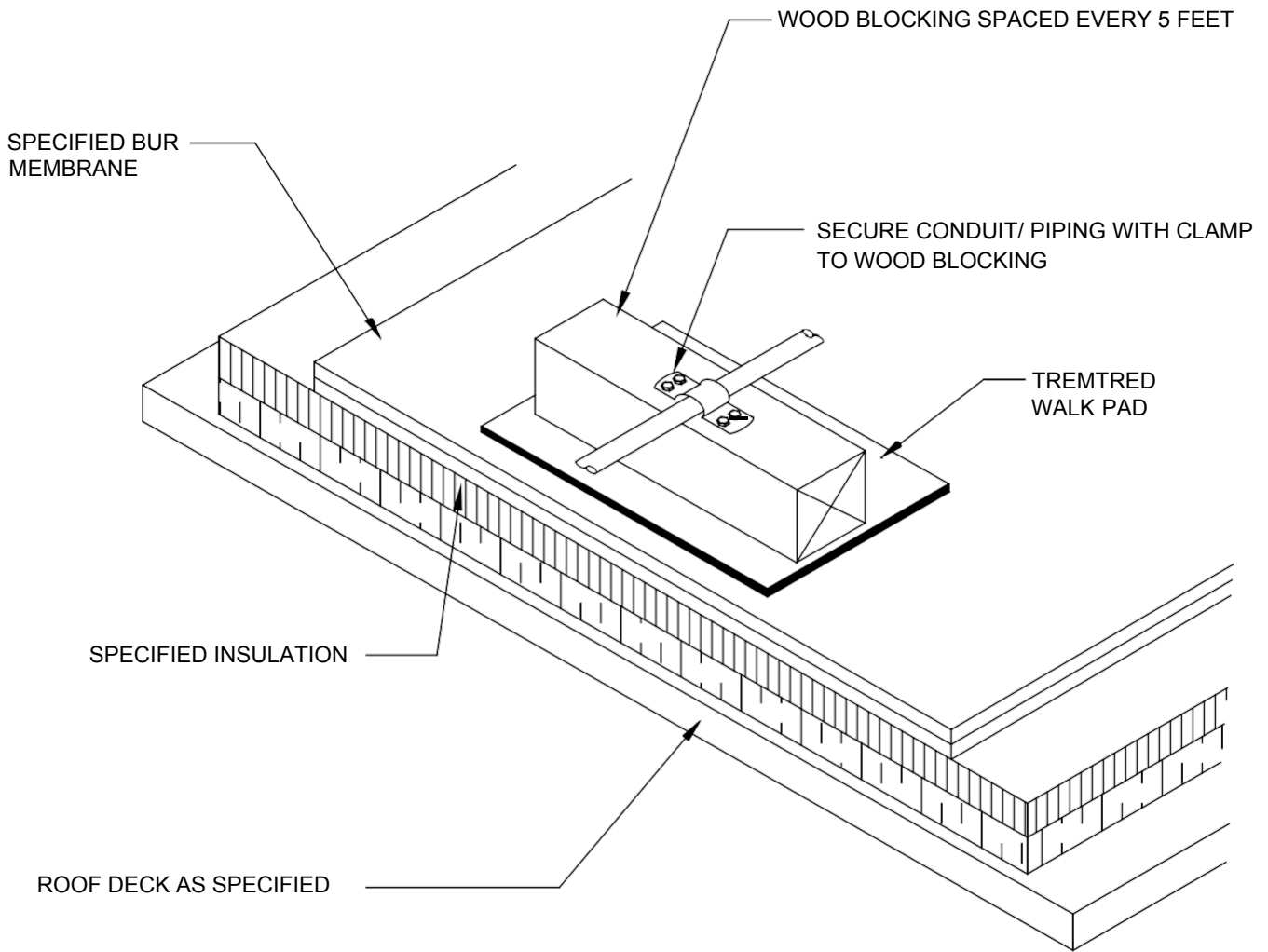

BUILT UP ROOFING
 HOT/COLD CONDUIT OR PIPING SUPPORT
 DWG NO. 28

N.T.S.



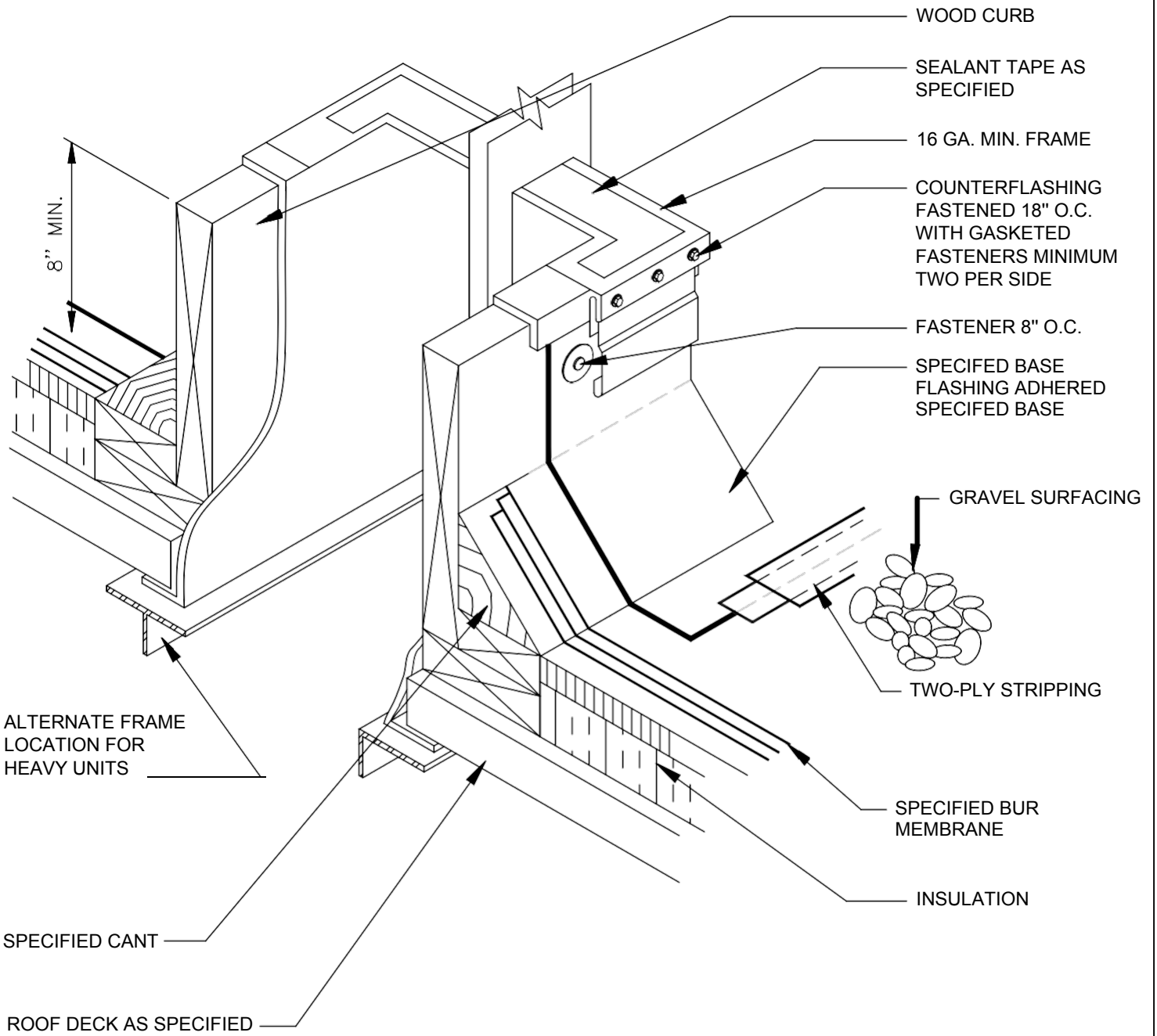

BUILT-UP ROOFING
 HOT/COLD BASE FLASHING
 CURB FOR AIR HANDLING UNIT

DWG NO. 03

N.T.S.

TREMCO
 ROOFING & BUILDING MAINTENANCE

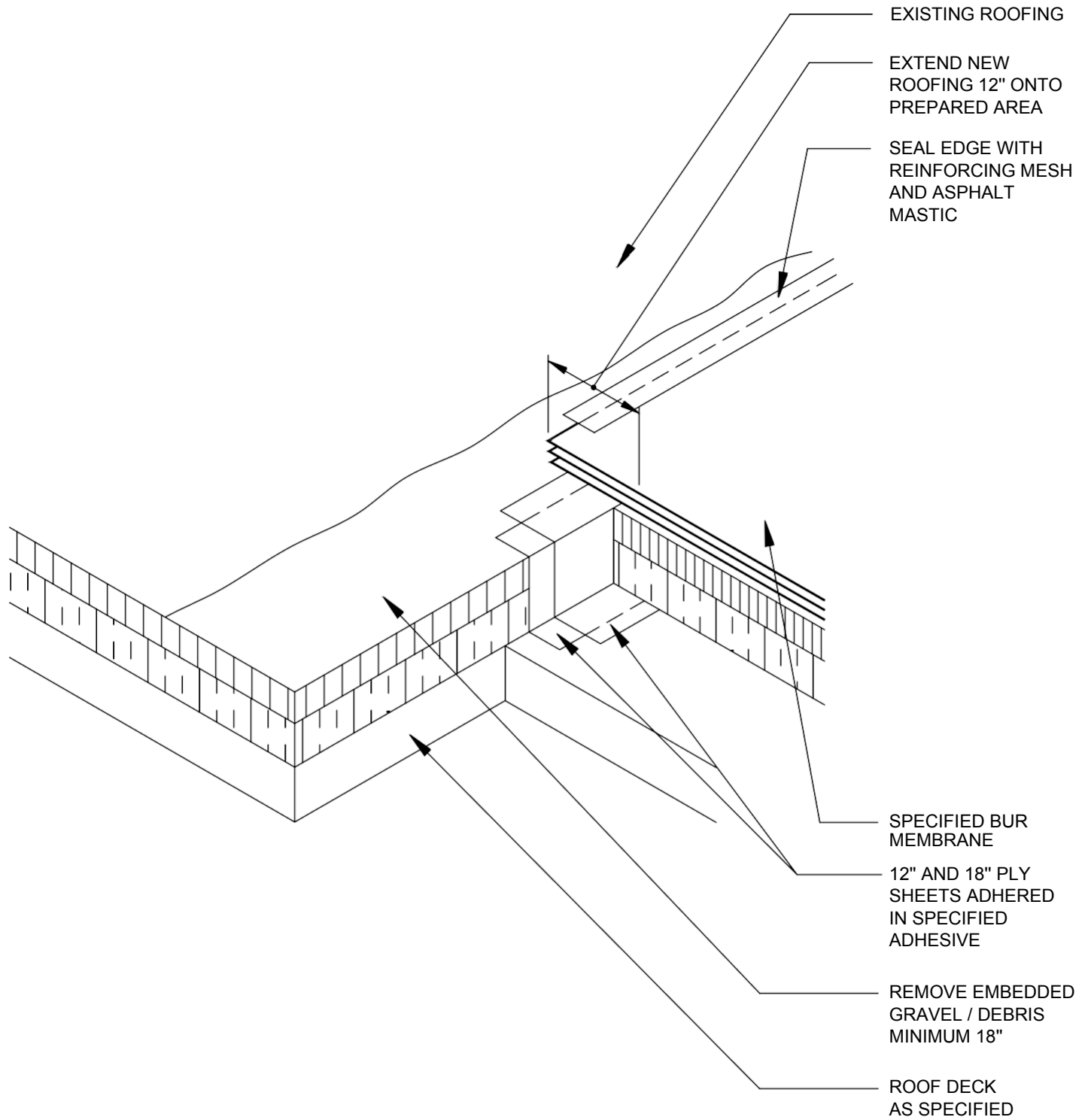

NOTES

1. BEFORE NEXT DAY'S WORK, REMOVE TEMPORARY TIE-IN AND INSULATION FILLERS

BUILT UP ROOFING
 HOT/COLD DAILY WATERSTOP / TIE IN
 DWG NO. 30

N.T.S.



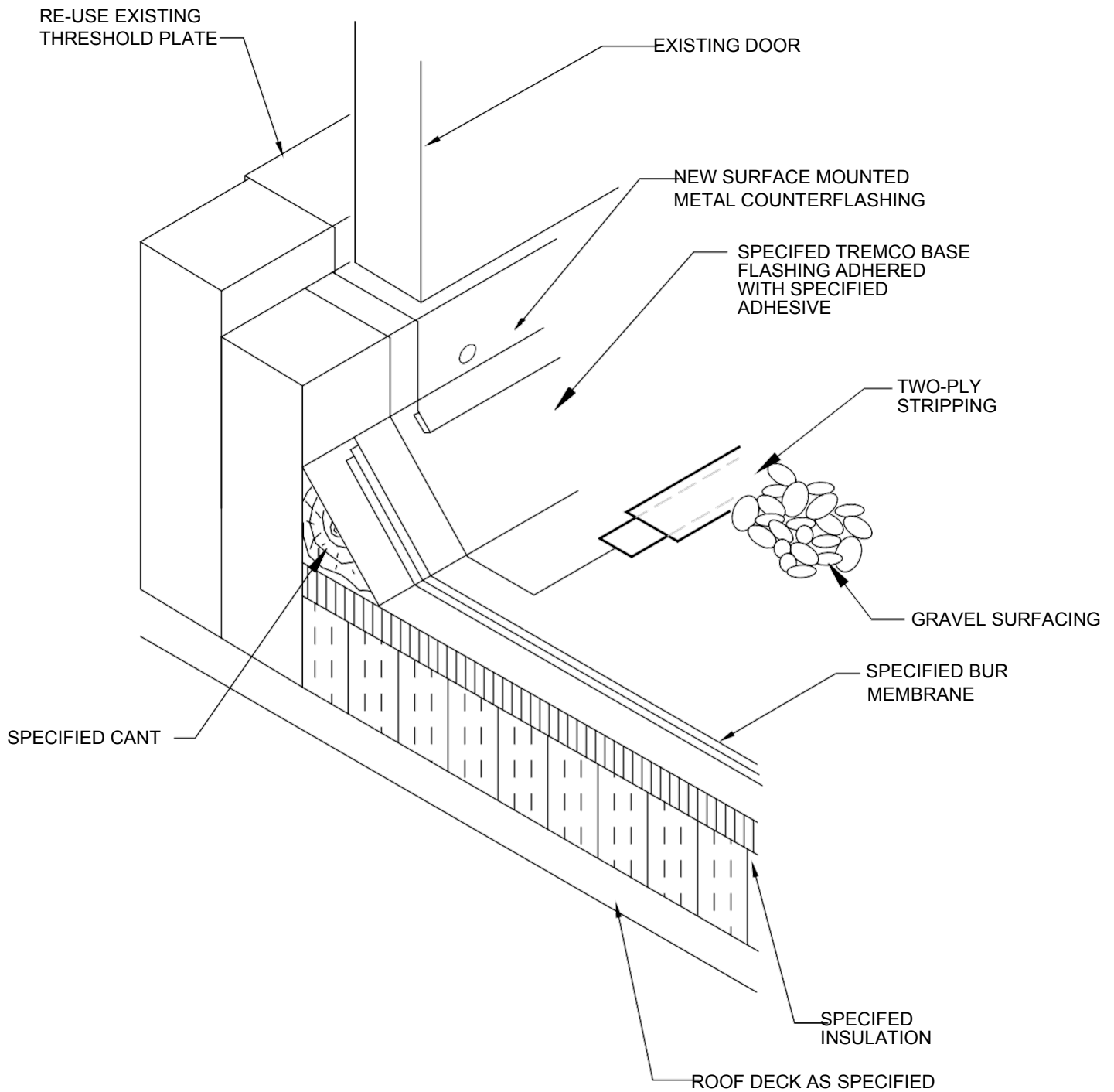

BUILT-UP ROOFING
HOT/COLD DOOR THRESHOLD
DWG NO. 24

N.T.S.

TREMCO
ROOFING & BUILDING MAINTENANCE

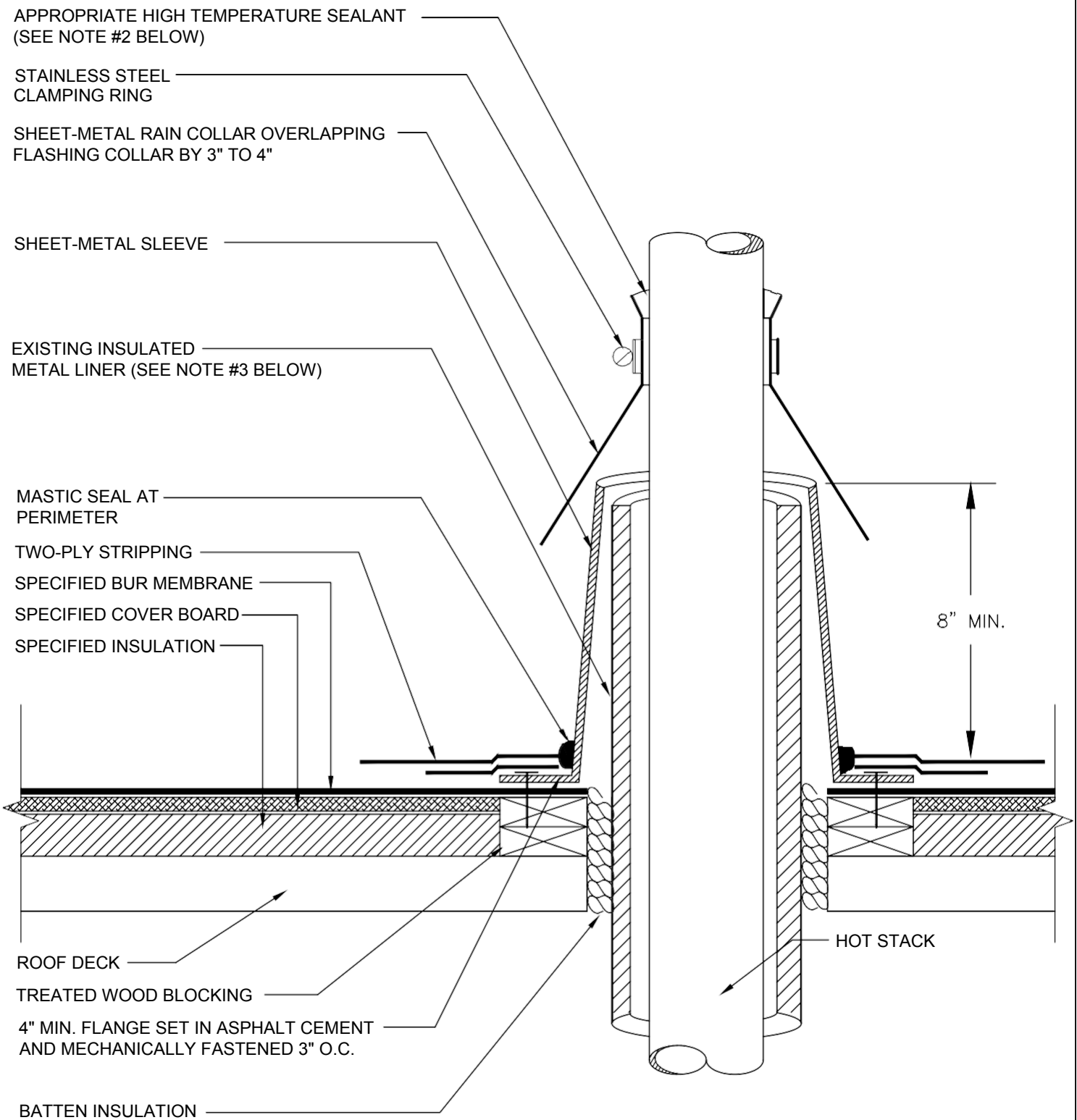

NOTES

1. PRIME ALL METAL SURFACES THAT WILL COME INTO CONTACT WITH THE SPECIFIED ADHESIVE.
2. WHEN HOT STACK SERVICE TEMPERATURE EXCEEDS 400 DEGREES, WELD OR SOLDER RAIN COLLAR TO PIPE IN LIEU OF INSTALLING SEALANT.
3. THE CLEARANCE REQUIRED BETWEEN THE HOT PIPE AND INSULATED METAL LINER WILL DEPEND ON THE TEMPERATURE OF THE MATERIAL HANDLED BY THE STACK.

BUILT-UP ROOFING HOT/COLD
HOT STACK PENETRATION

DWG NO. 07

N.T.S.

TREMCO
ROOFING & BUILDING MAINTENANCE

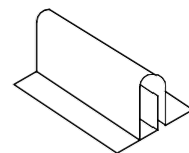

SECTION A-A

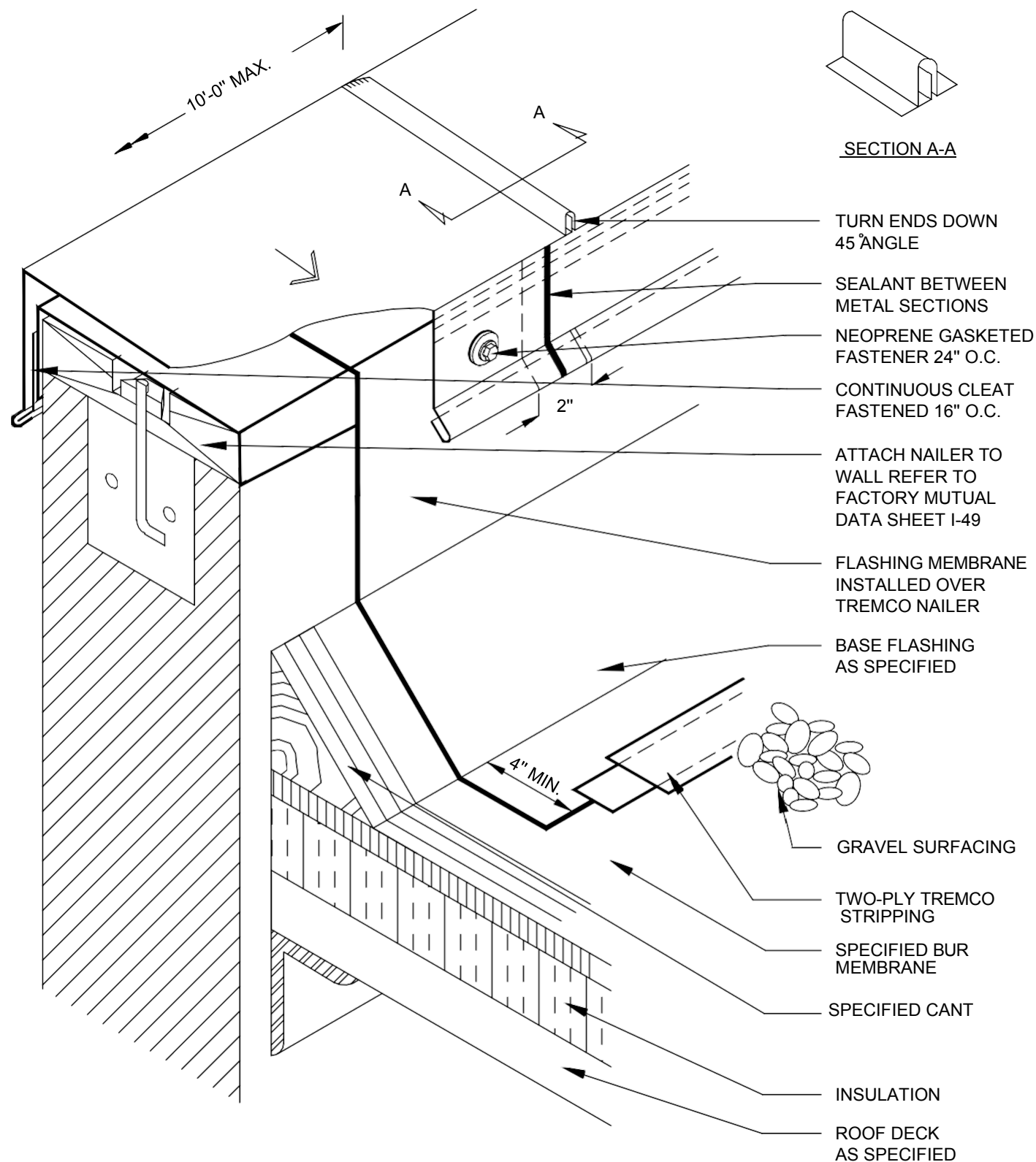

BUILT UP ROOFING
HOT/COLD LIGHT METAL PARAPET CAP

DWG NO. 36

N.T.S.

TREMCO
ROOFING & BUILDING MAINTENANCE

NAIL WOOD CANT TO
BLOCKING 2 ROWS
STAGGERED EACH
ROW 24" O.C.

3 1/2" MIN.

1/2" MIN.
10'-0" MAX.

FASTEN 18" O.C. w/
NEOPRENE GASKETED
FASTENERS

JOINT COVER PLATE
SET IN TWO BEADS
OF TREMCO SEALANT

4" - 6"

4" MIN.

SPECIFIED TWO-PLY
STRIPPING

TWO-PLY BASE
FLASHING

GRAVEL SURFACING

SPECIFIED BUR MEMBRANE

SPECIFIED INSULATION

ROOF DECK
AS SPECIFIED

CONTINUOUS CLEAT
FASTENED 16" O.C.

NOTES

1. SECURE COVER PLATE USING TWO FASTENERS WITH NEOPRENE GASKETS AT THE CENTER OF EACH FASCIA SECTION

BUILT UP ROOFING
HOT/COLD LIGHT-METAL ROOF EDGE, RAISED

DWG NO. 35

N.T.S.

TREMCO
ROOFING & BUILDING MAINTENANCE

JOINT COVER 4"-6" WIDE
SET IN ASPHALT CEMENT
AND SECURED USING TWO
FASTENERS THROUGH THE
GAP IN THE FASCIA FLANGE

FASTENERS 3" O.C.
STAGGERED 2 ROWS

FELT
ENVELOPE

1/2" MIN.
10'-0" MAX.

TWO-PLY STRIPPING

GRAVEL SURFACING

METAL SET IN ASPHALT
CEMENT- PRIME FLANGE
BEFORE STRIPPING

SPECIFIED BUR MEMBRANE

SPECIFIED TREMCO
ADHESIVE

SPECIFIED INSULATION

ROOF DECK
AS SPECIFIED

ATTACH WOOD NAILER
TO WALL

CONTINUOUS CLEAT
FASTENED 16" O.C.

NOTES

1. ALL METAL SURFACES SHALL BE PRIMED BEFORE CONTACT WITH TREMCO PRIMERS

BUILT UP ROOFING
HOT/COLD LIGHT-METAL ROOF EDGE

DWG NO. 34

N.T.S.



SPECIFIED BUR
MEMBRANE

BASE PLY
PER SPEC.

TRETTRED
WALK PAD

WOOD BLOCKING

SECURE SUPPORTS
AND OR EQUIPMENT
TO WOOD BLOCKING

SPECIFIED INSULATION

WOOD BLOCKING TO EQUAL
FINISHED INSULATION HEIGHT

ROOF DECK AS SPECIFIED

BUILT-UP ROOFING HOT/COLD
LOAD BEARING SUPPORT

DWG NO. 10

N.T.S.

TREMCO
ROOFING & BUILDING MAINTENANCE

GRAVEL SURFACING



CAULK DRAWBAND
w/ SPECIFIED
ELASTOMERIC
SEALANT

STORM COLLAR

METAL SLEEVE

MASTIC SEAL AT
PERIMETER

SET FLANGE IN
SPECIFIED MASTIC
AND MECHANICALLY
FASTEN 3" O.C.
PRIME FLANGE
BEFORE STRIPPING

TWO-PLY STRIPPING

BATTEN INSULATION

WOOD NAILER SECURED
TO DECK w/ APPROPRIATE
FASTENERS, 2 ROWS
STAGGERED EACH
ROW 24" O.C.

PROJECTION

SPECIFIED BUR
MEMBRANE

SPECIFIED INSULATION

ROOF DECK
AS SPECIFIED

BUILT-UP ROOFING HOT/COLD
METAL SLEEVE AND STORM COLLAR

DWG NO. 06

N.T.S.



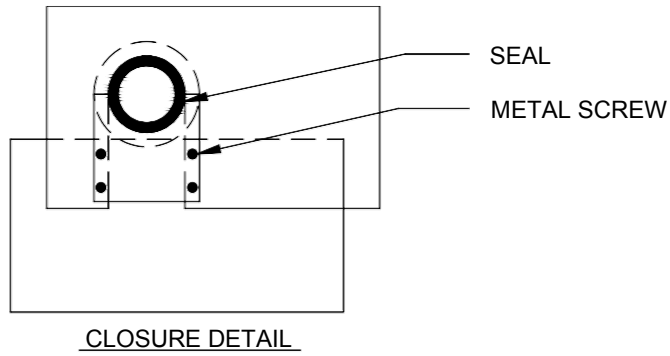

INSULATE INSIDE OF METAL WORK IN COLD CLIMATES

GRAVEL SURFACING

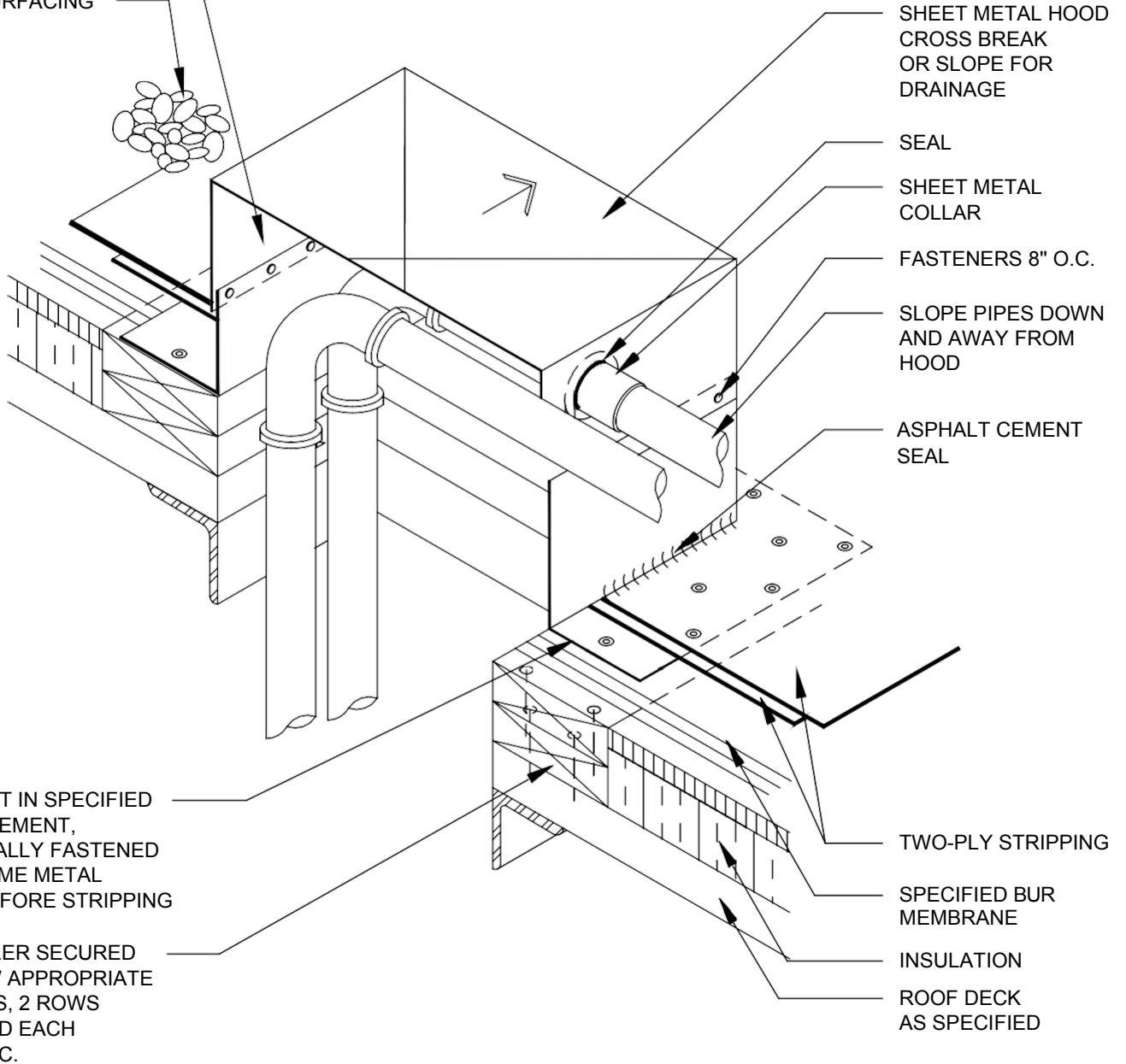

BUILT UP ROOFING
HOT/COLD PIPING THROUGH ROOF DECK

DWG NO. 18

N.T.S.

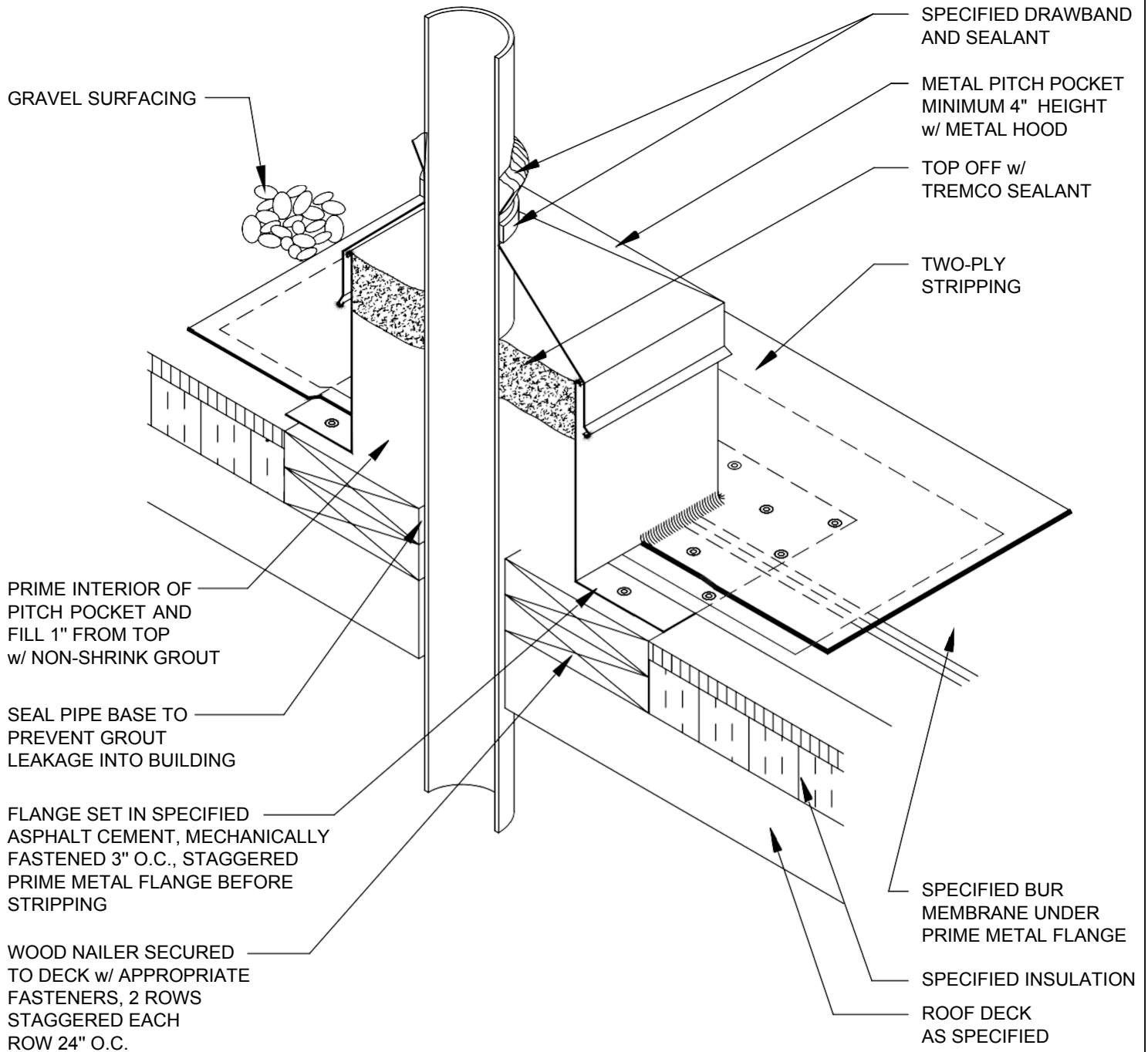

BUILT UP ROOFING
HOT/COLD PITCH POCKET WITH GROUT

DWG NO. 33

N.T.S.

TREMCO
ROOFING & BUILDING MAINTENANCE

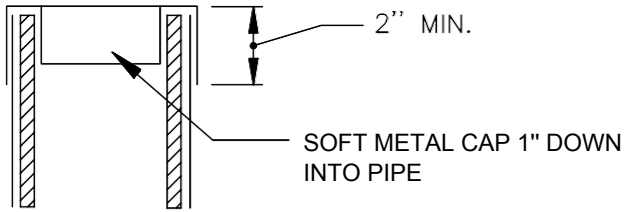

FOR PLUMBING VENTS WITH DIAMETERS LESS THAN 2" USE SOFT METAL CAPS

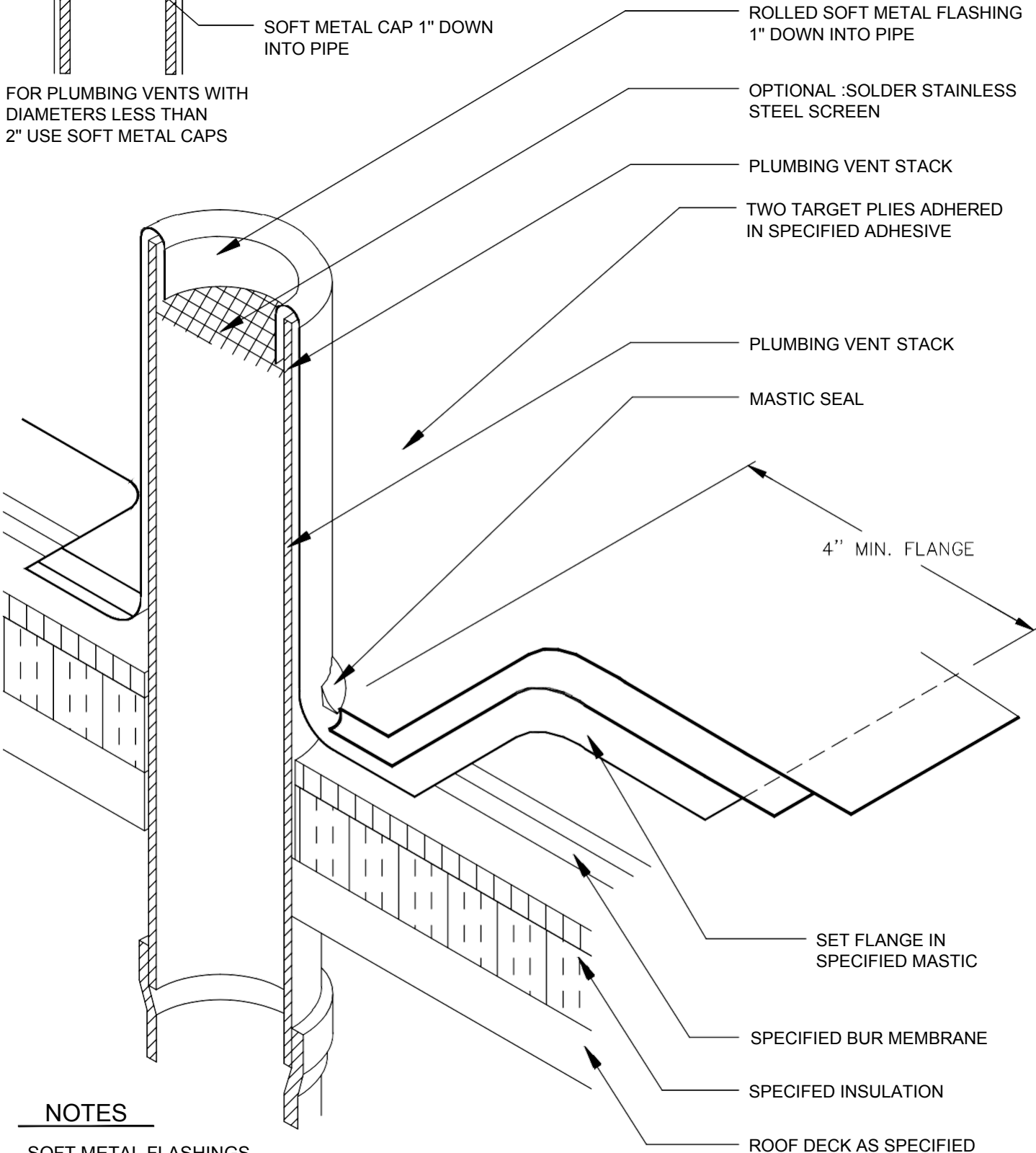

NOTES

SOFT METAL FLASHINGS

1. SHEET LEAD: MINIMUM 4 LB. (20kg²/m) PER SQ.FT.
2. SHEET COPPER: MINIMUM 16 OZ. IF COPPER FLASHING IS INSTALLED OVER AN IRON OR STEEL PIPE, WRAP AN ASPHALT COATED ROOFING FELT TO PREVENT DIRECT CONTACT BETWEEN TWO DISSIMILAR METALS.

**BUILT-UP ROOFING HOT/COLD
PLUMBING VENT FLASHING**

DWG NO. 08

N.T.S.



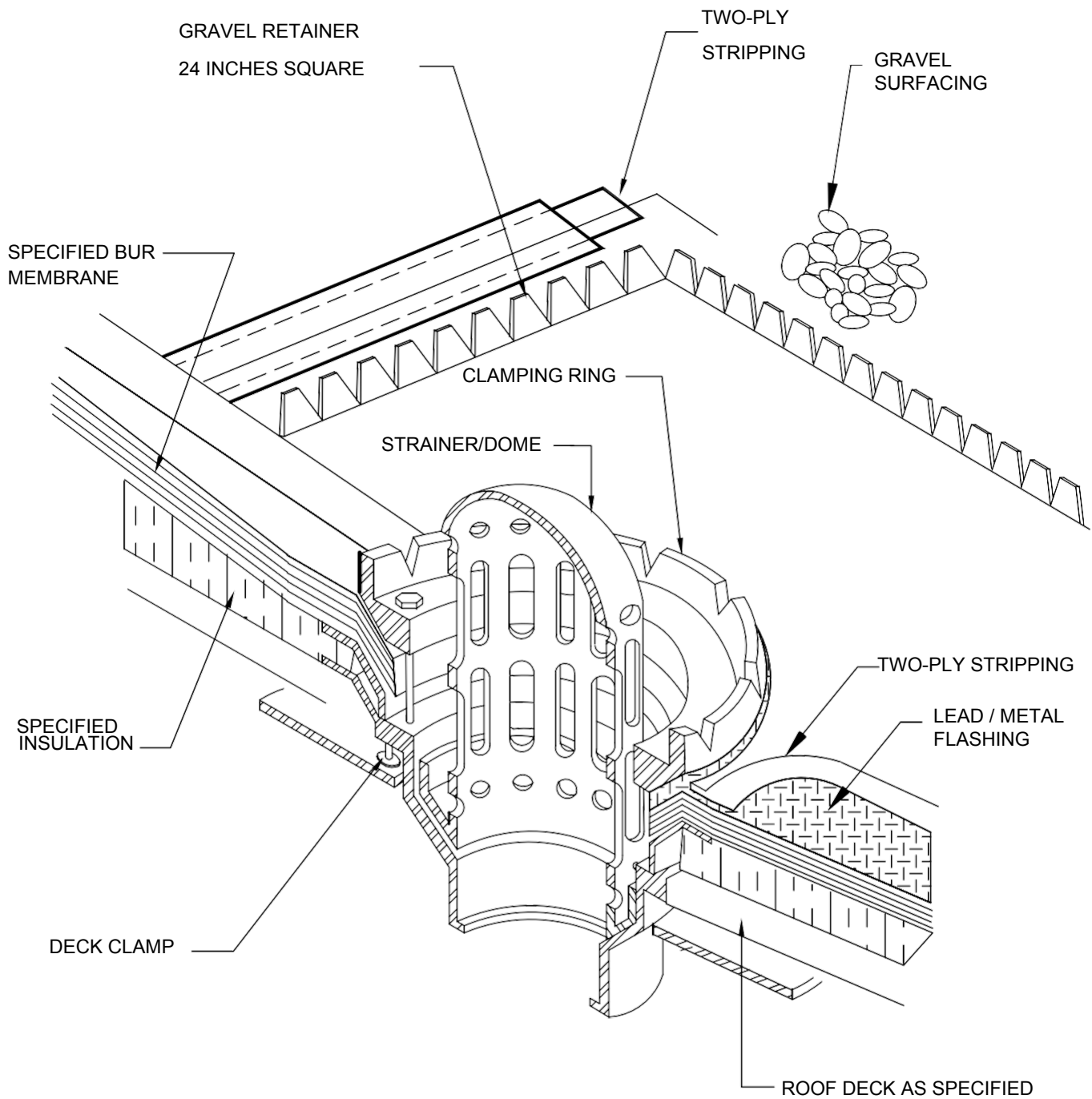

NOTES

1. PRIME ALL METAL SURFACES THAT WILL COME INTO CONTACT WITH ADHESIVES

BUILT UP ROOFING
HOT/COLD ROOF DRAIN WITH GRAVEL GUARD
DWG NO. 37

N.T.S.

TREMCO
ROOFING & BUILDING MAINTENANCE

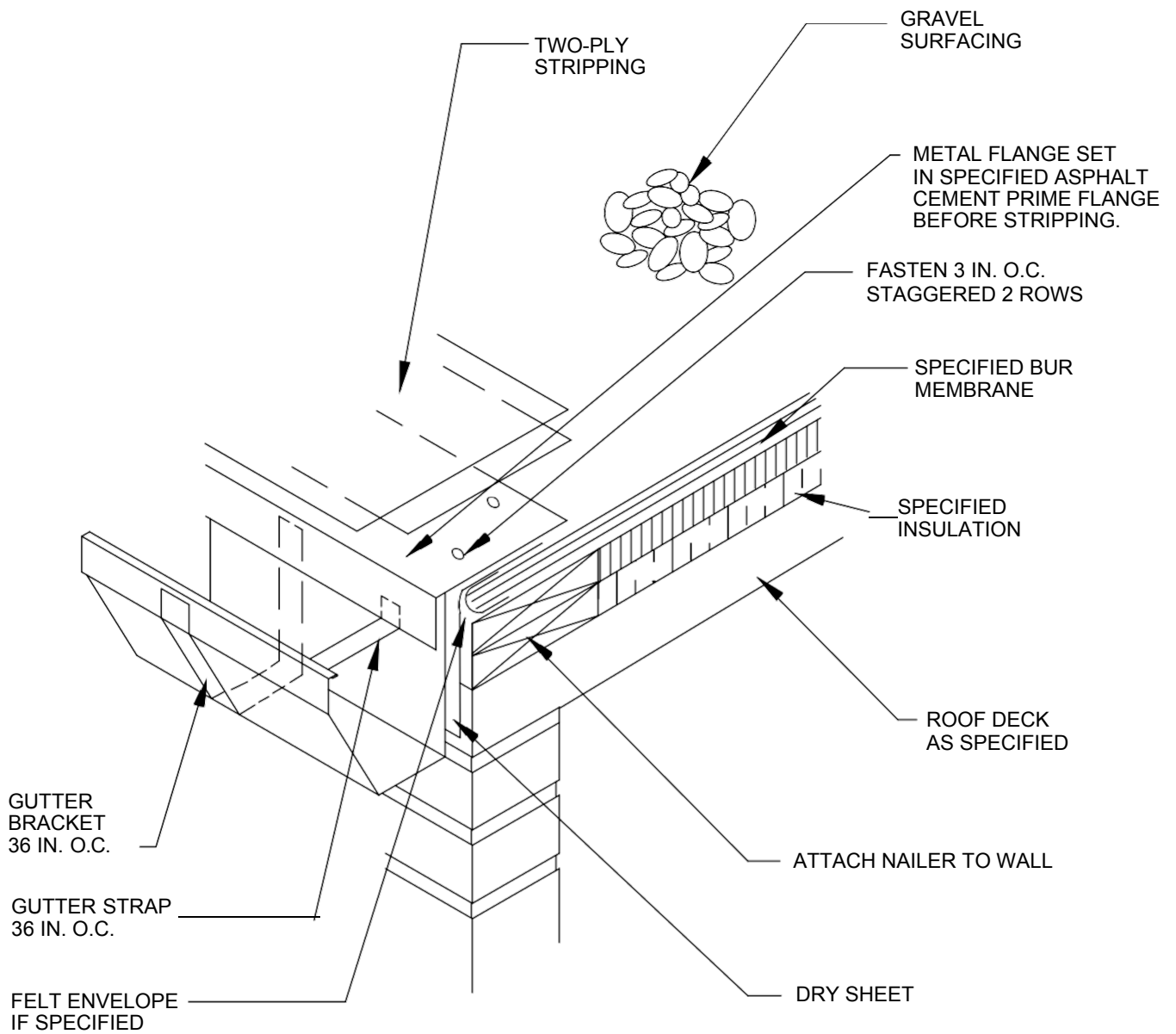

NOTES

1. SLOPE GUTTER TO DOWNSPOUTS
1/4 IN./FT. MINIMUM

BUILT-UP ROOFING
HOT/COLD ROOF EDGE WITH GUTTER

DWG NO. 21

N.T.S.

TREMCO
ROOFING & BUILDING MAINTENANCE

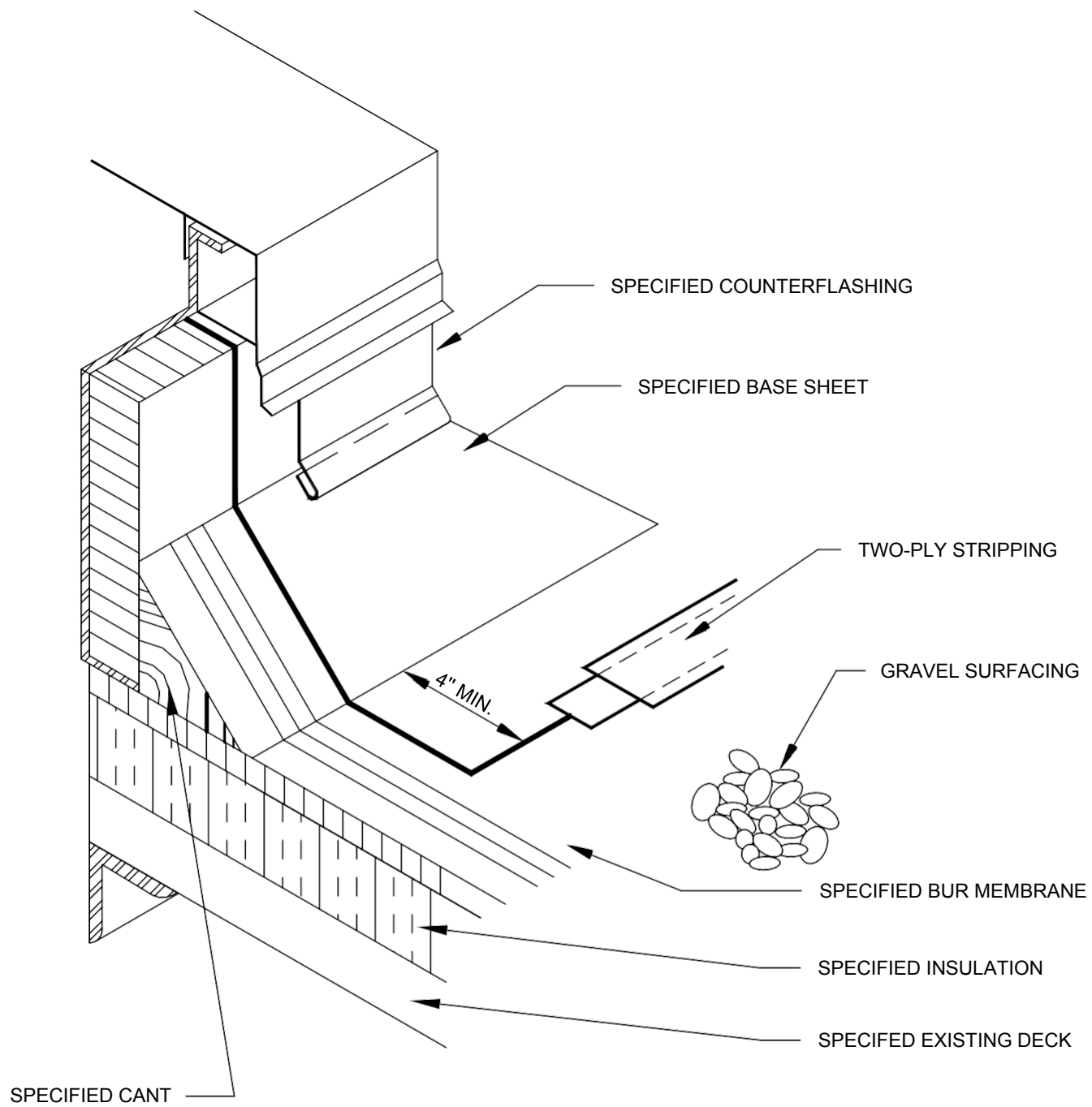

BUILT UP ROOFING
HOT/COLD ROOF HATCH
DWG NO. 25

N.T.S.

TREMCO
ROOFING & BUILDING MAINTENANCE

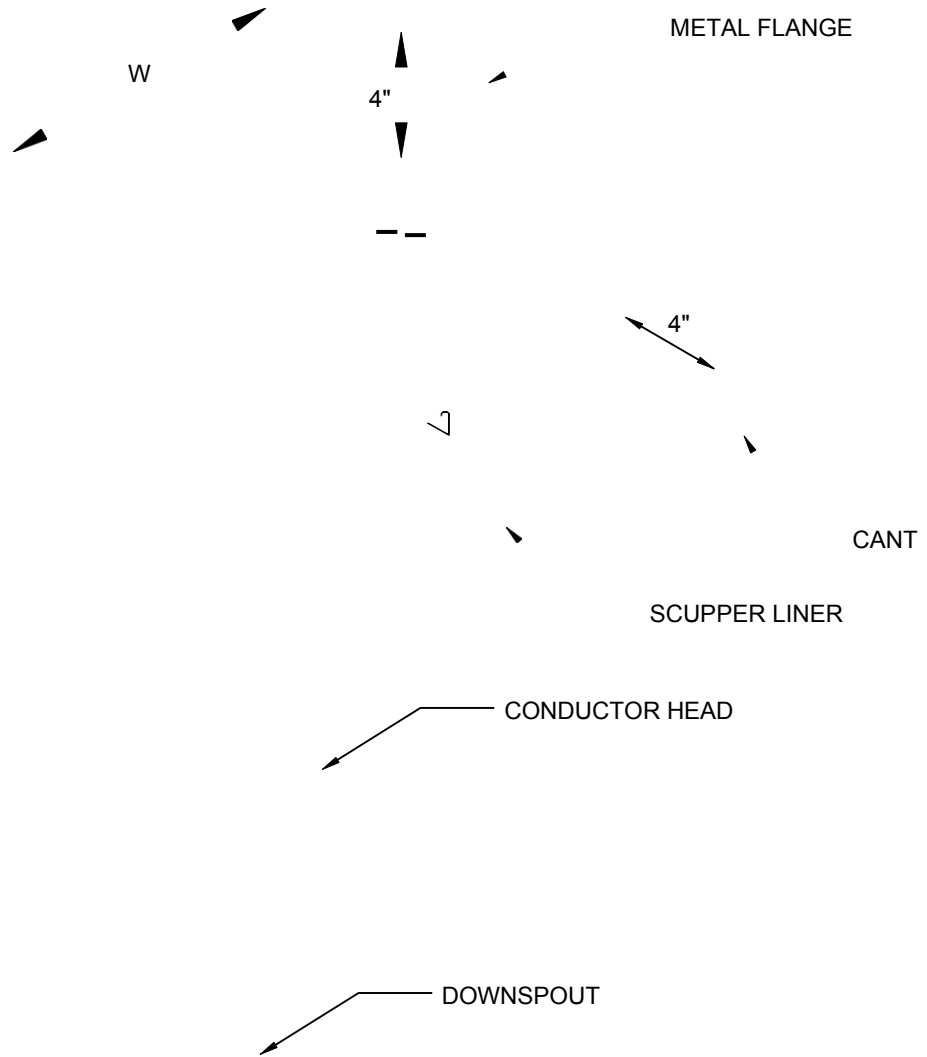

NOTES

1. W = NOMINAL WIDTH OF PARAPET
2. MATCH EXISTING CONDUCTOR HEAD PROFILE AND SIZE
3. FABRICATE AND INSTALL COMPONENTS IN ACCORDANCE WITH PROJECT SPECIFICATIONS AND SMACNA REQUIREMENTS AND STANDARDS

BUILT UP ROOFING
HOT/COLD THRU-WALL SCUPPER
WITH CONDUCTOR HEAD

DWG NO. 32

N.T.S.



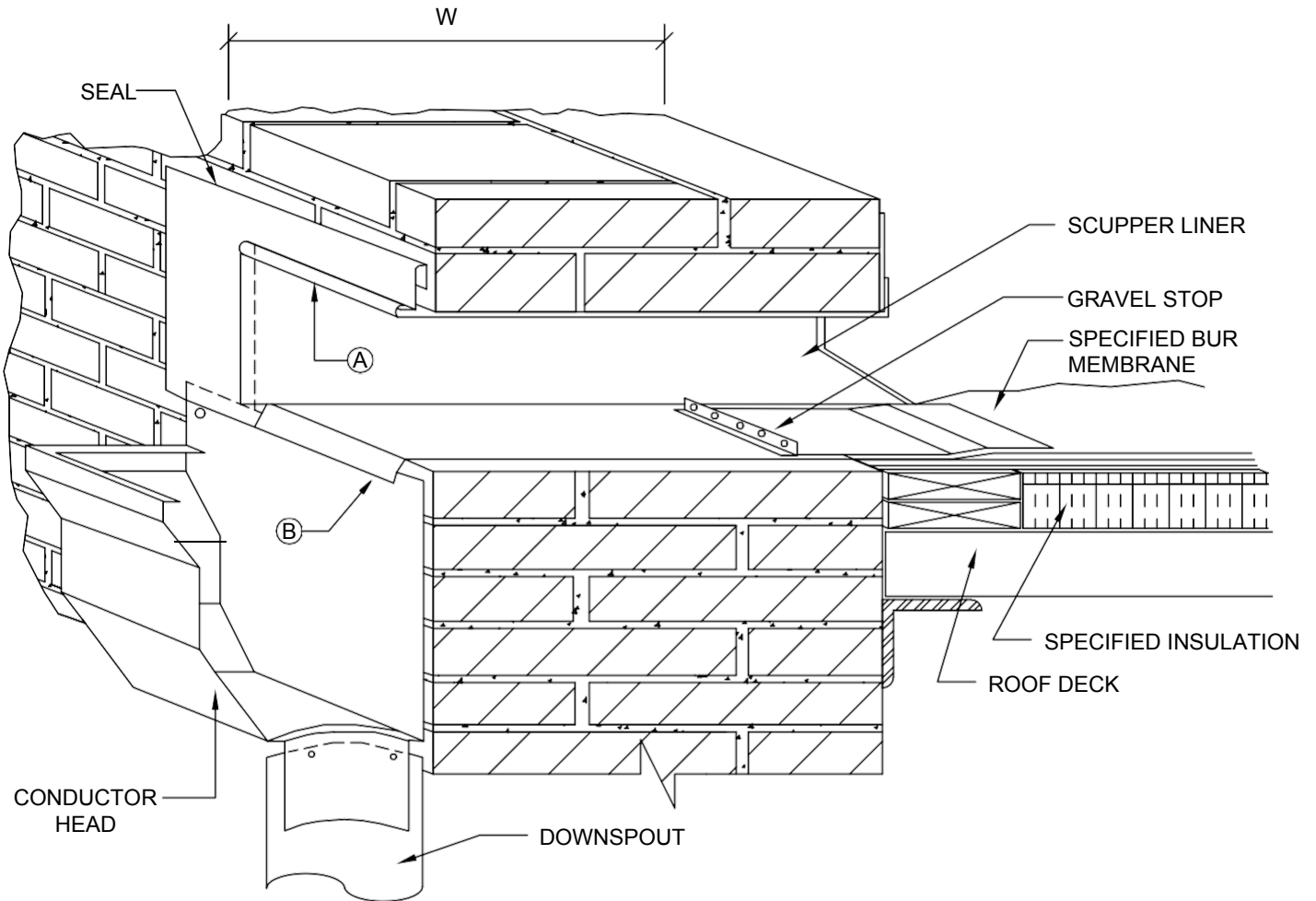
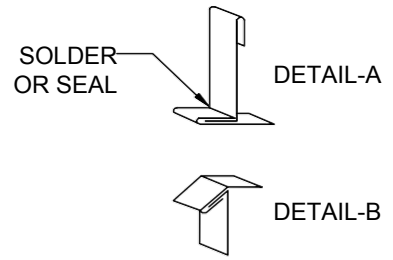

NOTES

1. MATCH EXISTING CONDUCTOR HEAD PROFILE AND SIZE.
2. W = NOMINAL WIDTH OF PARAPET
3. FABRICATE AND INSTALL COMPONENTS IN ACCORDANCE WITH PROJECT SPECIFICATIONS AND SMACNA REQUIREMENTS AND STANDARDS.

BUILT UP ROOFING
 HOT/COLD THRU-WALL
 SCUPPER WITH CONDUCTOR HEAD

DWG NO. 31

N.T.S.



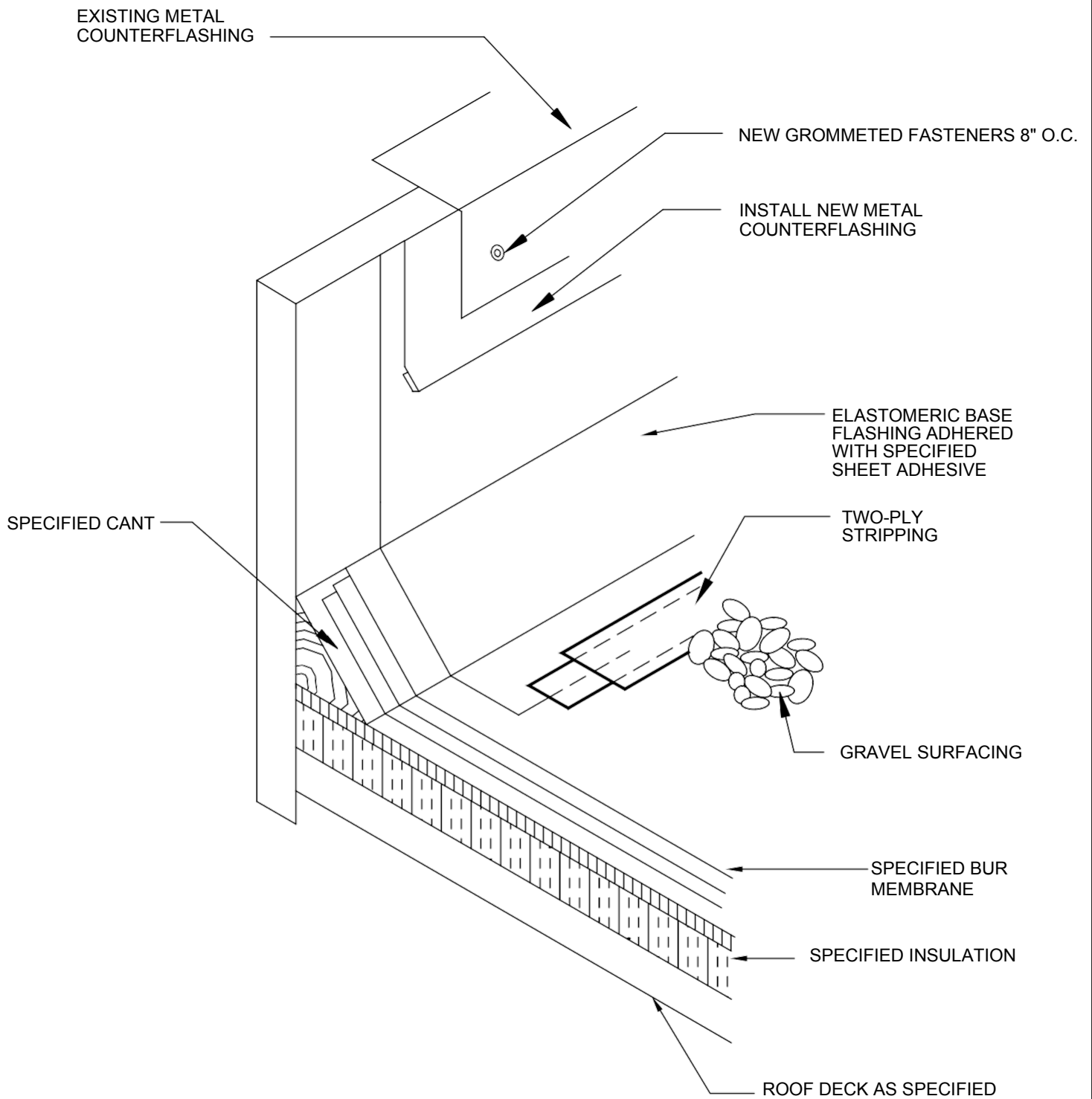

BUILT UP ROOFING
HOT/COLD SLIP METAL SKIRT FLASHING
DWG NO. 27

N.T.S.

TREMCO
ROOFING & BUILDING MAINTENANCE

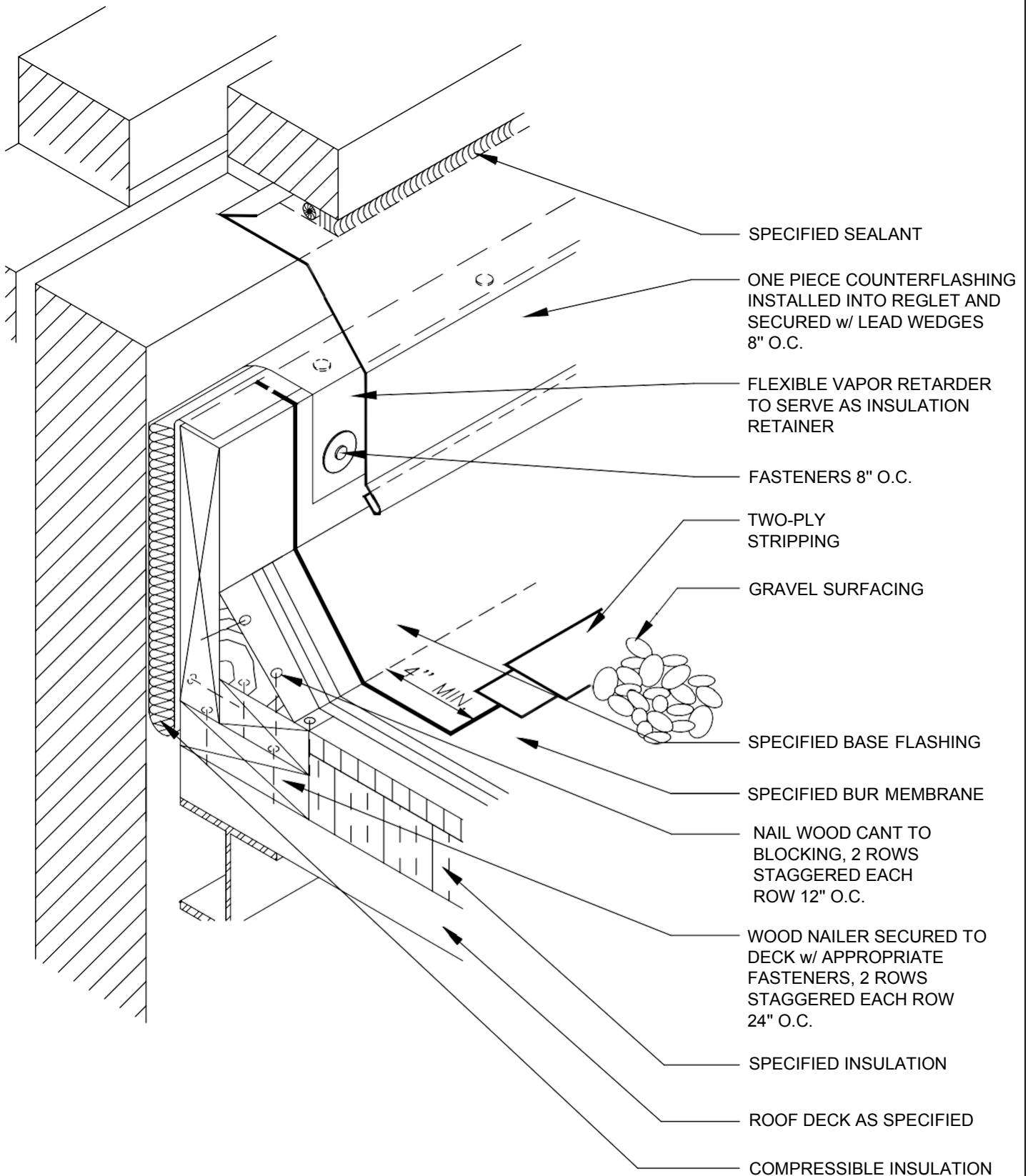

**BUILT-UP ROOF
 HOT/COLD WALL FLASHING FOR
 NON-WALL-SUPPORTED DECK**

DWG NO. 11

N.T.S.



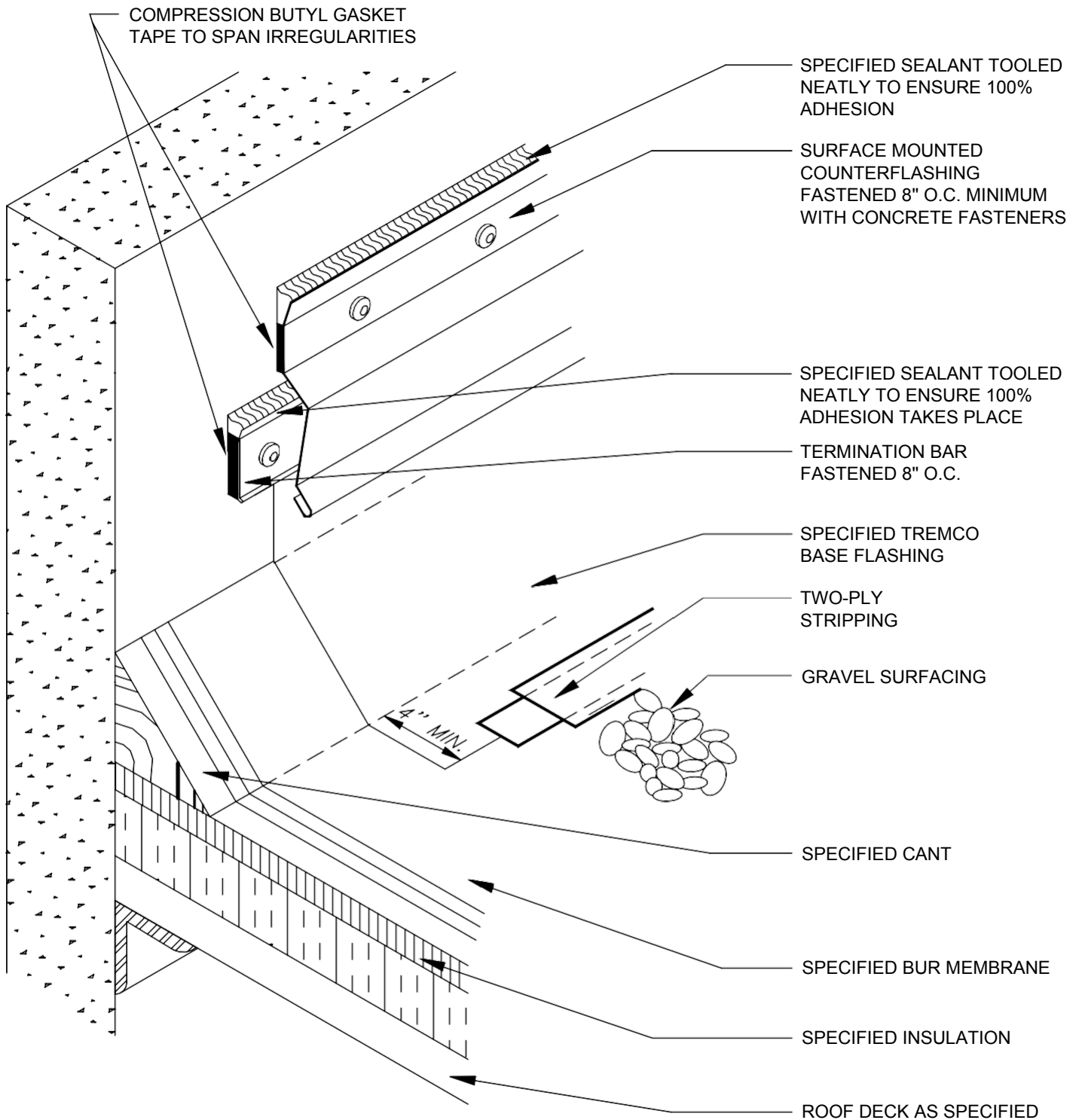

BUILT-UP ROOFING
HOT/COLD WALL FLASHING FOR
CONCRETE WALLS AND PARAPETS

DWG NO. 12

N.T.S.

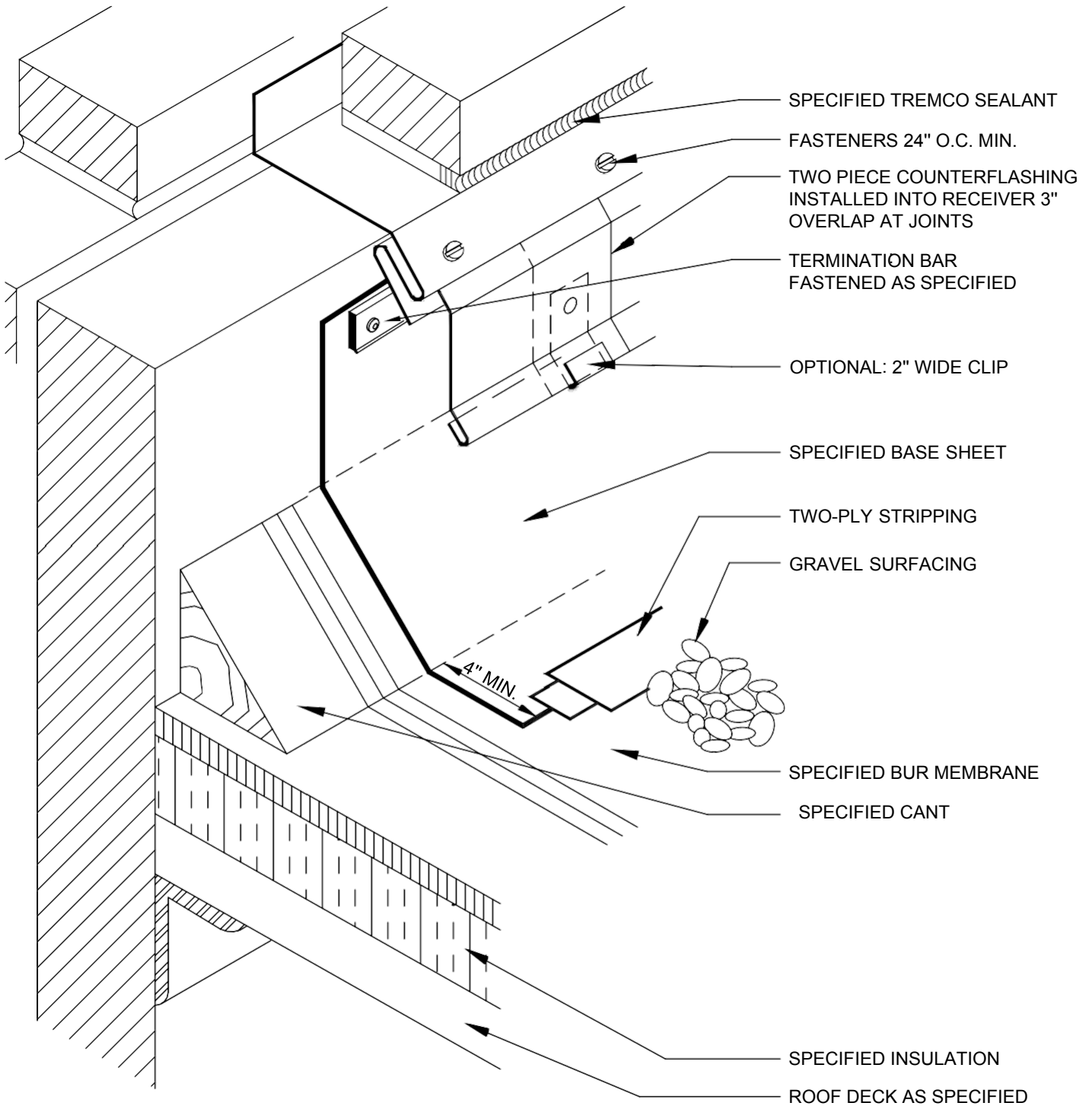

BUILT UP ROOFING HOT/COLD
 WALL FLASHING WALL SUPPORTED DECK

DWG NO. 38

N.T.S.

TREMCO
 ROOFING & BUILDING MAINTENANCE

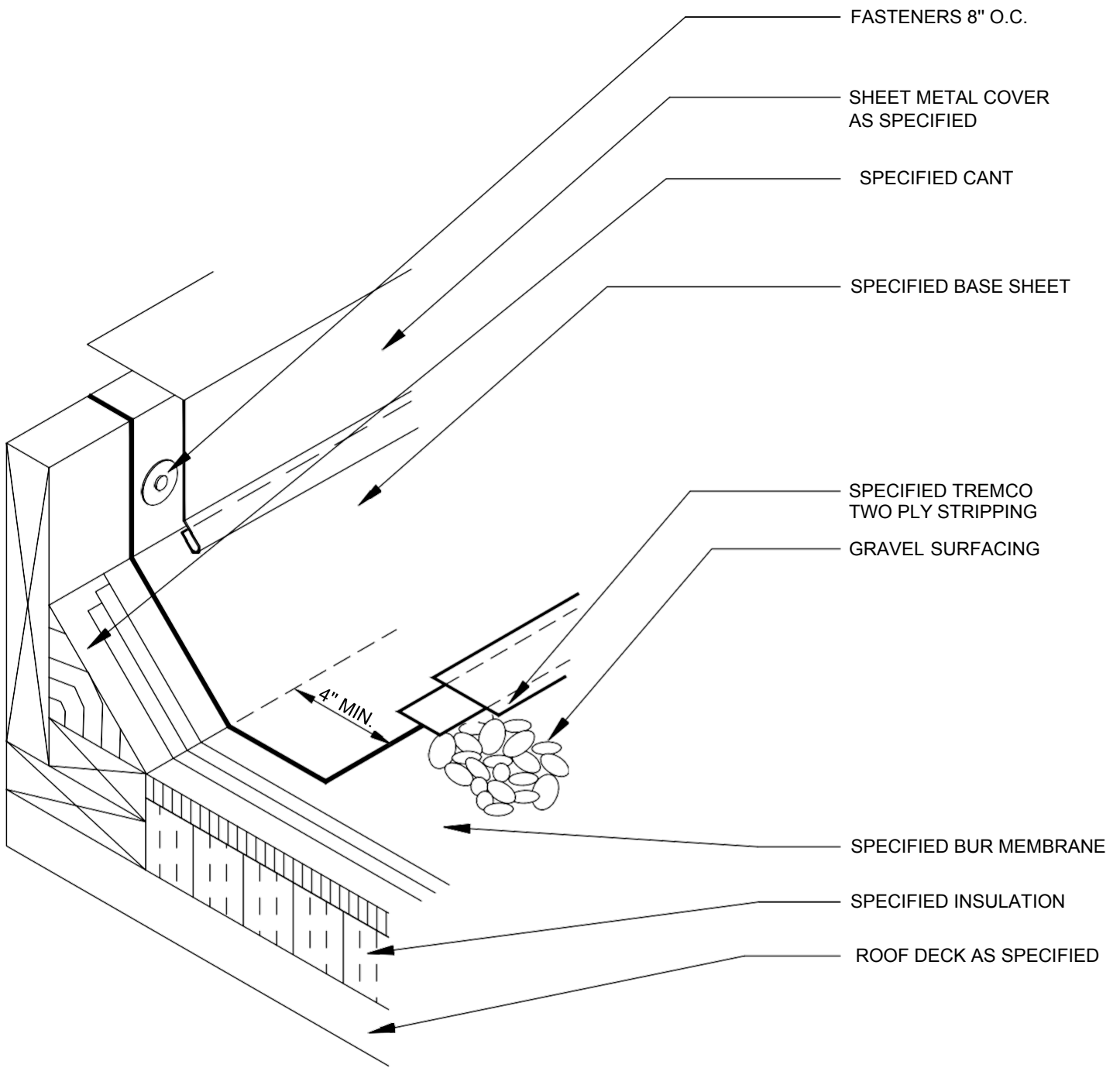

BUILT-UP ROOFING
HOT/COLD WOOD CURB
DWG NO. 17

N.T.S.

TREMCO
ROOFING & BUILDING MAINTENANCE