

Request for Quotes

This is not a sealed bid. Quotes can be emailed or faxed to the Office of the Purchasing Division.

Deadline for Quotes is November 18th, 2022 at 2:30pm Eastern Time.

The City of Knoxville requests quotes for a 2017 model Gillig diesel-electric hybrid bus fairing kit. Specification is below. When awarded, the supplier must be able to deliver the fairing kit as soon as possible, keeping Knoxville Area Transit's maintenance department well informed of shipping information as this item is required for a "down bus". A City purchase order shall be awarded to the responsive bid from the responsible bidder who provides the lowest quoted price. Pricing must include shipping. Note this procurement is funded in whole or in part with a grant from the Federal Transit Administration. Federal contract clauses listed within this document apply.

Specifications:

- Gillig Part Number 20-65522C000-189669 FAIRING KIT, EV4.
- Pictures from the Gillig parts manual below provides additional clarification as to exactly what is required.
- This item is required for a 2017 Gillig Diesel-Electric Hybrid Bus serial number 15GGB3010H3189674.
- OEM or equal aftermarket kit is acceptable. Aftermarket kit, if offered, must be complete and an exact fit on the bus with no modifications required.
- Price must include shipping.
- Delivery address is Knoxville Area Transit located at 1135 E. Magnolia Avenue, Knoxville, TN 37917.



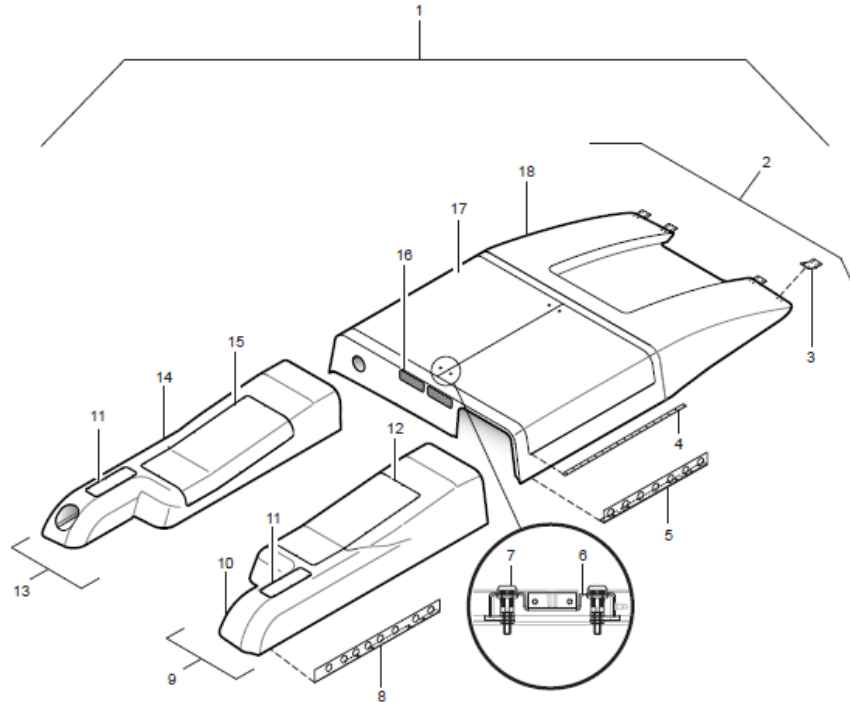

ITEM	PART NO.	DESCRIPTION	QTY.
1.	20-65522C000-189669	Roof Fairing Kit (includes items 2, 9 & 13)	1
2.	20-57913-002	Fairing Assy, Roof (includes items 3-7 & 16-18)	1
3.	20-53690-001	Angle, Shroud Mounting	2
4.	20-53459-000	Hinge, Access Door	2
5.	20-53385-000R	Angle, Shroud Mounting, Curbside	1
	20-53385-000L	Angle, Shroud Mounting, Streetside	1
6.	20-53386-000	Channel, Supt	1
7.	54-57594-000	Latch, Pawl	4
	82-41314-001	Latch, Compression	4
8.	20-54551-000R	Angle, Shroud Mounting, Curbside	1
	20-54551-000L	Angle, Shroud Mounting, Streetside	1
9.	20-60797-002R	Fairing Assy, Hybrid Curbside Pontoon (includes items 8, 10, 11 & 12)	1
10.	20-54267-003R	Fairing, Roof Curbside	1
11.	20-54329-000	Cover, Roof Fairing	2
12.	20-54330-000R	Cover, Fairing Curbside	1
13.	20-60797-002L	Fairing Assy, Hybrid Streetside Pontoon (includes items 8, 11, 14 & 15)	1
14.	20-54267-003L	Fairing, Roof Streetside	1
15.	20-54330-000L	Cover, Fairing Streetside	1
16.	20-57563-000	Screen, Fairing	1
17.	20-53377-000	Door, Access	2
18.	20-53376-001	Fairing, Roof w/Extended Nose	1

MODIFICATIONS: If modifications to this document are necessary, such changes will be made in the form of an addendum, posted to the Purchasing website: www.knoxvilletn.gov/bids. It is the vendor's responsibility to review the website to ascertain whether such addenda have been posted.

INCLEMENT WEATHER: During periods of inclement weather, the Purchasing Division will enact the following procedures with regard to solicitations and weather delays:

- If City offices are closed due to inclement weather on the date that quotes are due into the Purchasing Office, all solicitations due that same day will be moved to the next operational business day.
- The City of Knoxville shall not be liable for any commercial carrier's decision regarding deliveries during inclement weather.

In order for your quote to be considered for award, your completed form must be received by the Purchasing Office via email, fax, or hard copy no later than 2:30 p.m. (Eastern Time) on November 18, 2022. Late submissions shall not be accepted.

Prior to submitting their quote, vendors are to be registered with the Purchasing Division through the City of Knoxville's online Vendor Registration system. Instructions for registering on-line are available at www.knoxvilletn.gov/purchasing.

Federal Requirements:

Americans with Disabilities Act Compliance. With regard to the services performed, the Contractor will comply with all applicable requirements of the Americans with Disabilities Act, 42 U.S.C. §12101, et seq.; section 504 of the Rehabilitation Act of 1973, as amended, 29 USC §794; the Architectural Barriers Act of 1968, as amended, 42 U.S.C. §4151 et seq., and Federal transit law at 49 USC §5332 and any implementing requirements FTA may issue. The Contractor agrees that it will not discriminate against individuals on the basis of disability.

Access to Records and Reports. The following access to records requirements apply to this Contract:

1. Record Retention. The Contractor will retain, and will require its subcontractors of all tiers to retain, complete and readily accessible records related in whole or in part to the contract, including, but not limited to, data, documents, reports, statistics, sub-agreements, leases, subcontracts, arrangements, other third party agreements of any type, and supporting materials related to those records.

2. Retention Period. The Contractor agrees to comply with the record retention requirements in accordance with 2 C.F.R. § 200.333. The Contractor shall maintain all books, records, accounts and reports required under this Contract for a period of at not less than three (3) years after the date of termination or expiration of this Contract, except in the event of litigation or settlement of claims arising from the performance of this Contract, in which case records shall be maintained until the disposition of all such litigation, appeals, claims or exceptions related thereto.

3. Access to Records. The Contractor agrees to provide sufficient access to FTA and its contractors to inspect and audit records and information related to performance of this contract as reasonably may be required.

4. Access to the Sites of Performance. The Contractor agrees to permit FTA and its contractors access to the sites of performance under this contract as reasonably may be required.

Civil Rights Requirements. The City of Knoxville is an Equal Opportunity Employer. As such, the City agrees to comply with all applicable Federal civil rights laws and implementing regulations. Apart from inconsistent requirements imposed by Federal laws or regulations, the City agrees to comply with the requirements of 49 U.S.C. § 5323(h) (3) by not using any Federal assistance awarded by FTA to support procurements using exclusionary or discriminatory specifications. Under this Agreement, the Contractor shall at all times comply with the following requirements and shall include these requirements in each subcontract entered into as part thereof.

1. Nondiscrimination. In accordance with Federal transit law at 49 U.S.C. § 5332, the Contractor agrees that it will not discriminate against any employee or applicant for employment because of race, color, religion, national origin, sex, disability, or age. In addition, the Contractor agrees to comply with applicable Federal implementing regulations and other implementing requirements FTA may issue.

2. Race, Color, Religion, National Origin, Sex. In accordance with Title VII of the Civil Rights Act, as amended, 42 U.S.C. § 2000e et seq., and Federal transit laws at 49 U.S.C. § 5332, the Contractor

agrees to comply with all applicable equal employment opportunity requirements of U.S. Department of Labor (U.S. DOL) regulations, "Office of Federal Contract Compliance Programs, Equal Employment Opportunity, Department of Labor," 41 C.F.R. chapter 60, and Executive Order No. 11246, "Equal Employment Opportunity in Federal Employment," September 24, 1965, 42 U.S.C. § 2000e note, as amended by any later Executive Order that amends or supersedes it, referenced in 42 U.S.C. § 2000e note. The Contractor agrees to take affirmative action to ensure that applicants are employed, and that employees are treated during employment, without regard to their race, color, religion, national origin, or sex (including sexual orientation and gender identity). Such action shall include, but not be limited to, the following: employment, promotion, demotion or transfer, recruitment or recruitment advertising, layoff or termination; rates of pay or other forms of compensation; and selection for training, including apprenticeship. In addition, the Contractor agrees to comply with any implementing requirements FTA may issue.

3. Age. In accordance with the Age Discrimination in Employment Act, 29 U.S.C. §§ 621-634, U.S. Equal Employment Opportunity Commission (U.S. EEOC) regulations, "Age Discrimination in Employment Act," 29 C.F.R. part 1625, the Age Discrimination Act of 1975, as amended, 42 U.S.C. § 6101 et seq., U.S. Health and Human Services regulations, "Nondiscrimination on the Basis of Age in Programs or Activities Receiving Federal Financial Assistance," 45 C.F.R. part 90, and Federal transit law at 49 U.S.C. § 5332, the Contractor agrees to refrain from discrimination against present and prospective employees for reason of age. In addition, the Contractor agrees to comply with any implementing requirements FTA may issue.

4. Disabilities. In accordance with section 504 of the Rehabilitation Act of 1973, as amended, 29 U.S.C. § 794, the Americans with Disabilities Act of 1990, as amended, 42 U.S.C. § 12101 et seq., the Architectural Barriers Act of 1968, as amended, 42 U.S.C. § 4151 et seq., and Federal transit law at 49 U.S.C. § 5332, the Contractor agrees that it will not discriminate against individuals on the basis of disability. In addition, the Contractor agrees to comply with any implementing requirements FTA may issue.

Domestic Preferences for Procurements. To the greatest extent practical under a Federal award, the Contractor shall provide a preference for the purchase, acquisition, or use of goods, products, or materials produced in the United States (including but not limited to iron, aluminum, steel, cement, and other manufactured products). For the purpose of this clause,

a. "Produced in the United States" means, for iron and steel products, that all manufacturing processes, from the initial melting stage through the application of coatings, occurred in the United States.

b. "Manufactured Products" means items and construction materials composed in whole or in part of non-ferrous metals such as aluminum, plastics and polymer-based products such as polyvinyl chloride pipe; aggregates such as concrete, glass, including optical fiber; and lumber.

Prohibition for certain Telecommunications and Video Surveillance Service/Equipment (2 CFR 200.216, 2 CFR 200 App II(K)) Where the awarded contract requires provision of equipment, services, or systems involving telecommunications and/or video surveillance systems, equipment, and/or service, Contractors shall not provide such system, equipment, or service described in Public Law 115-232, section 889. This includes telecommunications equipment produced by Huawei Technologies Company, ZTE Corporation, Hytera Communications Corporation, Hangzhou Hikvision Digital Technology Company, Dahua Technology Company or any subsidiary or affiliate of such entities.

Recycled Products/Recovered Materials Requirements (42 U.S.C. 6962; 40 CFR Part 247; 2 CFR 200.323, 2 CFR 200 App II(j)) - The Contractor agrees to provide a preference for those products and services that conserve natural resources, protect the environment, and are energy efficient by complying

with and facilitating compliance with Section 6002 of the Resource Conservation and Recovery Act, as amended, 42 U.S.C. § 6962, and U.S. Environmental Protection Agency (U.S. EPA), "Comprehensive Procurement Guideline for Products Containing Recovered Materials," 40 C.F.R. part 247.

Cargo Preference Requirements. For equipment, materials, or commodities which may be transported by ocean vessels, the contractor agrees:

1. To use privately owned United States-Flag commercial vessels to ship at least 50 percent of the gross tonnage (computed separately for dry bulk carriers, dry cargo liners, and tankers) involved, whenever shipping any equipment, material, or commodities pursuant to the underlying contract to the extent such vessels are available at fair and reasonable rates for United States-Flag commercial vessels;

2. To furnish within 20 working days following the date of loading for shipments originating within the United States or within 30 working days following the date of leading for shipments originating outside the United States, a legible copy of a rated, "on-board" commercial ocean bill-of-lading in English for each shipment of cargo described in the preceding paragraph to the Division of National Cargo, Office of Market Development, Maritime Administration, Washington, DC 20590 and to the FTA recipient (through the contractor in the case of a subcontractor's bill-of-lading.)

3. To include these requirements in all subcontracts issued pursuant to this contract when the subcontract may involve the transport of equipment, material, or commodities by ocean vessel.

Federal Changes. The contractor shall at all times comply with all applicable FTA regulations, policies, procedures and directives, including without limitation those listed directly or by reference in the Master Agreement between the City of Knoxville and FTA, as they may be amended or promulgated from time to time during the term of this contract. The contractor's failure to so comply shall constitute a material breach of this contract.

Disadvantaged Business Enterprise (DBE) (49 CFR Part 26) –

1. This contract is subject to the requirements of Title 49, Code of Federal Regulations, Part 26, Participation by Disadvantaged Business Enterprises in Department of Transportation Financial Assistance Programs. These requirements are in addition to all other equal opportunity employment requirements of this contract. The City of Knoxville shall make all determinations with regard to whether or not a Bidder/Offerer is in compliance with the requirements stated herein. In assessing compliance, the City of Knoxville may consider during its review of the Bidder/Offerer's submission package, the Bidder/Offerer's documented history of non-compliance with DBE requirements on previous contracts with the City of Knoxville.

2. A separate contract goal has not been established for this procurement.

3. The prime contractor and subcontractors shall not discriminate on the basis of race, color, national origin, or sex in the performance of this contract. The contractor shall carry out applicable requirements of 49 CFR Part 26 in the award and administration of DOT-assisted contracts. Failure by the contractor to carry out these requirements is a material breach of this contract, which may result in the termination of this contract or such other remedy as the City of Knoxville deems appropriate, which may include, but is not limited to:

- a. Withholding progress payments;
- b. Assessing sanctions;
- c. Liquidated damages; and/or
- d. Disqualifying the contractor from future bidding as non-responsible. (49 CFR 26.13(b)).

4. Each subcontract the contractor signs with a subcontractor must include the assurance in the subparagraph above (see 49 CFR 26.13(b)). The successful bidder/offeror will be required to report its DBE participation obtained through race-neutral means throughout the period of performance.

5. All bidders/proposers are required to submit the Subcontractor Information Form below for all subcontractors, both DBE and non-DBE.

6. The contractor is required to pay all of its subcontractors performing work related to this contract for satisfactory performance of that work no later than 30 days after the contractor's receipt of payment for that work from the City of Knoxville. Delays in payment must be approved in writing by the City of Knoxville. In addition, the contractor agrees to return retainage payments to each subcontractor within thirty (30) days after the City's payment of retainage to the prime. Any delay or postponement of payment from the above referenced timeframe may occur only for good cause following written approval of the City of Knoxville. This clause applies to both DBE and non-DBE subcontractors.

7. The contractor must promptly notify the City of Knoxville, whenever a DBE subcontractor performing work related to this contract is terminated or fails to complete its work, and must make good faith efforts to engage another DBE subcontractor to perform at least the same amount of work. The contractor may not terminate any DBE subcontractor and perform that work through its own forces or those of an affiliate without prior written consent of the City of Knoxville.

8. The City of Knoxville encourages all prime contractors to make reasonable efforts to utilize financial institutions owned and controlled by socially and economically disadvantaged individuals within the community. (49 CFR 26.27)

9. Please note Knoxville Area Transit's Disadvantaged Business Enterprise policy statement at the following Internet link: <https://www.katbus.com/246/2174/DBE-Policy-Statement>.

Energy Conservation Requirements (49 CFR Part 622, subpart C) - The contractor agrees to comply with mandatory standards and policies relating to energy efficiency, which are contained in the state energy conservation plan issued in compliance with the Energy Policy and Conservation Act.

Fly America Requirements.

1. Definitions. As used in this clause:

- a. "International air transportation" means transportation by air between a place in the United States and a place outside the United States or between two places both of which are outside the United States.
- b. "United States" means the 50 States, the District of Columbia, and outlying areas.
- c. "U.S.-flag air carrier" means an air carrier holding a certificate under 49 U.S.C. Chapter 411.

2. When Federal funds are used to fund travel, Section 5 of the International Air Transportation Fair Competitive Practices Act of 1974 (49 U.S.C. 40118) (Fly America Act) requires contractors, recipients, and others use U.S.-flag air carriers for U.S. Government-financed international air transportation of personnel (and their personal effects) or property, to the extent that service by those carriers is available. It requires the Comptroller General of the United States, in the absence of satisfactory proof of the necessity for foreign-flag air transportation, to disallow expenditures from funds, appropriated or otherwise established for the account of the United States, for international air transportation secured aboard a foreign-flag air carrier if a U.S.-flag air carrier is available to provide such services.

3. If available, the Contractor, in performing work under this contract, shall use U.S.-flag carriers for international air transportation of personnel (and their personal effects) or property.

4. In the event that the Contractor selects a carrier other than a U.S.-flag air carrier for international air transportation, the Contractor shall include a statement on vouchers involving such transportation essentially as follows:

**Statement of Unavailability of U.S.-Flag Air Carriers
(For International Air Transportation of Personnel or Property)**

International air transportation of persons (and their personal effects) or property by U.S.-flag air carrier was not available or it was necessary to use foreign-flag air carrier service for the following reasons. See FAR § 47.403. [State reasons]:

(End of statement)

5. The Contractor shall include the substance of this clause, including this paragraph (e), in each subcontract or purchase under this contract that may involve international air transportation.

Incorporation of Federal Transit Administration (FTA) Terms - Incorporation of Federal Transit Administration (FTA) Terms - The preceding provisions include, in part, certain Standard Terms and Conditions required by DOT, whether or not expressly set forth in the preceding contract provisions. All contractual provisions required by DOT, as set forth in FTA Circular 4220.1F, are hereby incorporated by reference. Anything to the contrary herein notwithstanding, all FTA mandated terms shall be deemed to control in the event of a conflict with other provisions contained in this Agreement. The Contractor shall not perform any act, fail to perform any act, or refuse to comply with any City of Knoxville requests, which would cause the City of Knoxville to be in violation of the FTA terms and conditions.

No Federal Government Obligation to Third Parties. The City of Knoxville and Contractor acknowledge and agree that, notwithstanding any concurrence by the Federal Government in or approval of the solicitation or award of the underlying Contract, absent the express written consent by the Federal Government, the Federal Government is not a party to this Contract and shall not be subject to any obligations or liabilities to the City of Knoxville, Contractor or any other party (whether or not a party to that contract) pertaining to any matter resulting from the underlying Contract. The Contractor agrees to include the above clause in each subcontract financed in whole or in part with Federal assistance provided by the FTA. It is further agreed that the clause shall not be modified, except to identify the subcontractor who will be subject to its provisions.

Notification to FTA - If a current or prospective legal matter that may affect the Federal Government emerges, Contractor must promptly notify the City, the FTA Chief Counsel, and FTA Regional Counsel for the Region where the City is located. The Contractor must also include a similar notification requirement in all third-party agreements (sub-contracts) and require each third-party participant (sub-contractor) to include an equivalent provision in its sub-agreements at every tier, for any agreement that is a "covered transaction" according to 2 C.F.R. §§ 180.220 and 1200.200.

a. The types of legal matters that require notification include, but are not limited to, a major dispute, breach, default, litigation, or naming the Federal Government as a party to litigation or a legal disagreement in any forum for any reason.

b. Matters that may affect the Federal Government include, but are not limited to, the Federal Government's interests in the Grant Award to the City of Knoxville, the accompanying Underlying Agreement, and any Amendments thereto, or the Federal Government's administration or enforcement of federal laws, regulations, and requirements.

c. Additional Notice to U.S. DOT Inspector General. The Contractor must promptly notify the City of Knoxville and the U.S. DOT Inspector General in addition to the FTA Chief Counsel and Regional Counsel for the Region in which the City is located, if the Contractor has knowledge of potential fraud, waste, or abuse occurring on a project receiving assistance from the FTA. The notification provision applies if a person has or may have submitted a false claim under the False Claims Act, 31 U.S.C. § 3729, et seq., or has or may have committed a criminal or civil violation of law pertaining to such matters as fraud, conflict of interest, bid rigging, misappropriation or embezzlement, bribery, gratuity, or similar misconduct involving federal assistance. This responsibility occurs whether the project is subject to this Agreement or another agreement involving a principle, officer, employee, agent of the Contractor. It also applies to subcontractors at any tier. Knowledge, as used in this paragraph, includes, but is not limited to, knowledge of a criminal or civil investigation by a Federal, state or local law enforcement or other investigative agency, a criminal indictment or civil complaint, or probable cause that could support a criminal indictment, or any other credible information without delay and without change.

Program Fraud and False or Fraudulent Statements and Related Acts.

1. The Contractor acknowledges that the provisions of the Program Fraud Civil Remedies Act of 1986, as amended, 31 U.S.C. § 3801 et seq. and U.S. DOT regulations, "Program Fraud Civil Remedies," 49 C.F.R. Part 31, apply to its actions pertaining to this Project. Upon execution of the underlying contract, the Contractor certifies or affirms the truthfulness and accuracy of any statement it has made, it makes, it may make, or causes to be made, pertaining to the underlying contract or the FTA assisted project for which this contract work is being performed. In addition to other penalties that may be applicable, the Contractor further acknowledges that if it makes, or causes to be made, a false, fictitious, or fraudulent claim, statement, submission, or certification, the Federal Government reserves the right to impose the penalties of the Program Fraud Civil Remedies Act of 1986 on the Contractor to the extent the Federal Government deems appropriate.

2. The Contractor also acknowledges that if it makes, or causes to be made, a false, fictitious, or fraudulent claim, statement, submission, or certification to the Federal Government under a contract connected with a project that is financed in whole or in part with Federal assistance originally awarded by FTA under the authority of 49 U.S.C. § 5307, the Government reserves the right to impose the penalties of 18 U.S.C. § 1001 and 49 U.S.C. § 5307(n)(1) on the Contractor, to the extent the Federal Government deems appropriate.

3. The Contractor agrees to include the above two clauses in each subcontract financed in whole or in part with Federal assistance provided by FTA. It is further agreed that the clauses shall not be modified, except to identify the subcontractor who will be subject to the provisions.

Safe Operation of Motor Vehicles

1. Seat belt use - The Contractor is encouraged to adopt and promote on-the-job seat belt use policies and programs for its employees and other personnel that operate company-owned vehicles, company-rented vehicles, or personally operated vehicles.

2. Distracted driving – The Contractor agrees to adopt and enforce workplace safety policies to decrease crashes caused by distracted drivers, including policies to ban text messaging while using an electronic device supplied by an employer, and driving a vehicle the driver owns or rents, a vehicle Contractor owns, leases, or rents, or a privately-owned vehicle when on official business in connection with the work performed under this agreement.

Debarment and Suspension.

1) This contract is a covered transaction for purposes of 2 C.F.R. pt. 180 and 2 C.F.R. pt. 3000. As such, the contractor is required to verify that none of the contractor's principals (defined at 2 C.F.R. § 180.995) or its affiliates (defined at 2 C.F.R. § 180.905) are excluded (defined at 2 C.F.R. § 180.940) or disqualified (defined at 2 C.F.R. § 180.935).

2) The contractor must comply with 2 C.F.R. pt. 180, subpart C and 2 C.F.R. pt. 3000, subpart C, and must include a requirement to comply with these regulations in any lower tier covered transaction it enters into. As such, the Contractor shall verify that its principals, affiliates, and subcontractors are eligible to participate in this federally funded contract and are not presently declared by any Federal department or agency to be:

- a) Debarred from participation in any federally assisted Award;
- b) Suspended from participation in any federally assisted Award;
- c) Proposed for debarment from participation in any federally assisted Award;
- d) Declared ineligible to participate in any federally assisted Award;
- e) Voluntarily excluded from participation in any federally assisted Award; or
- f) Disqualified from participation in any federally assisted Award.

3) By signing and submitting its bid, proposal, or contract, the bidder, proposer, or contractor certifies as follows:

- a) The certification in this clause is a material representation of fact relied upon by the City of Knoxville. If it is later determined by the City of Knoxville that the bidder or proposer knowingly rendered an erroneous certification, in addition to remedies available to the City of Knoxville, the Federal Government may pursue available remedies, including but not limited to suspension and/or debarment. The bidder, proposer, or awardee agrees to comply with the requirements of 2 CFR pt. 180 and 2 CFR pt. 3000 while this offer is valid and throughout the contract period. The bidder, proposer, or contractor further agrees to include a provision requiring such compliance in its resulting subcontracts or subrecipient agreements.

State Requirements:

Conflicts of Interest - The Grantee warrants that no part of the total Grant Contract Amount shall be paid directly or indirectly to an employee or official of the State of Tennessee as wages, compensation, or gifts in exchange for acting as an officer, agent, employee, subcontractor, or consultant to the Grantee in connection with any work contemplated or performed relative to this Grant Contract

Lobbying - The Grantee certifies, to the best of its knowledge and belief, that:

- a. No federally appropriated funds have been paid or will be paid, by or on behalf of the undersigned, to any person for influencing or attempting to influence an officer or employee of an agency, a Member of Congress, an officer or employee of Congress, or an employee of a Member of Congress in connection with the awarding of any federal contract, the making of any federal grant, the making of any federal loan, the entering into of any cooperative agreement, and the extension, continuation, renewal, amendment, or modification of any federal contract, grant, loan, or cooperative agreement.

- b. If any funds other than federally appropriated funds have been paid or will be paid to any person for influencing or attempting to influence an officer or employee of any agency, a Member of Congress, an officer or employee of Congress, or an employee of a Member of Congress in connection with this contract, grant, loan, or cooperative agreement, the Grantee shall complete and submit Standard Form-LLL, "Disclosure of Lobbying Activities," in accordance with its instructions.

c. The Grantee shall require that the language of this certification be included in the award documents for all sub-awards at all tiers (including subcontracts, sub-grants, and contracts under grants, loans, and cooperative agreements) and that all subrecipients shall certify and disclose accordingly.

This certification is a material representation of fact upon which reliance was placed when this transaction was made or entered into and is a prerequisite for making or entering into this transaction imposed by 31 U.S.C. § 1352

Nondiscrimination - The Grantee hereby agrees, warrants, and assures that no person shall be excluded from participation in, be denied benefits of, or be otherwise subjected to discrimination in the performance of this Grant Contract or in the employment practices of the Grantee on the grounds of handicap or disability, age, race, color, religion, sex, national origin, or any other classification protected by federal, Tennessee state constitutional, or statutory law. The Grantee shall, upon request, show proof of nondiscrimination and shall post in conspicuous places, available to all employees and applicants, notices of nondiscrimination.

Public Accountability - If the Grantee is subject to Tenn. Code Ann. § 8-4-401 et seq., or if this Grant Contract involves the provision of services to citizens by the Grantee on behalf of the State, the Grantee agrees to establish a system through which recipients of services may present grievances about the operation of the service program. The Grantee shall also display in a prominent place, located near the passageway through which the public enters in order to receive Grant supported services, a sign at least eleven inches (11") in height and seventeen inches (17") in width stating:

NOTICE: THIS AGENCY IS A RECIPIENT OF TAXPAYER FUNDING. IF YOU OBSERVE AN AGENCY DIRECTOR OR EMPLOYEE ENGAGING IN ANY ACTIVITY WHICH YOU CONSIDER TO BE ILLEGAL, IMPROPER, OR WASTEFUL, PLEASE CALL THE STATE COMPTROLLER'S TOLL-FREE HOTLINE: 1-800-232-5454.

The sign shall be on the form prescribed by the Comptroller of the Treasury. The Grantor State Agency shall obtain copies of the sign from the Comptroller of the Treasury, and upon request from the Grantee, provide Grantee with any necessary signs.

Public Notice - All notices, informational pamphlets, press releases, research reports, signs, and similar public notices prepared and released by the Grantee in relation to this Grant Contract shall include the statement, "This project is funded under a grant contract with the State of Tennessee, Department of Transportation." All notices by the Grantee in relation to this Grant Contract shall be approved by the State.

Records - The Grantee and any approved subcontractor shall maintain documentation for all charges under this Grant Contract. The books, records, and documents of the Grantee and any approved subcontractor, insofar as they relate to work performed or money received under this Grant Contract, shall be maintained in accordance with applicable Tennessee law. In no case shall the records be maintained for a period of less than five (5) full years from the date of the final payment. The Grantee's records shall be subject to audit at any reasonable time and upon reasonable notice by the Grantor State Agency, the Comptroller of the Treasury, or their duly appointed representatives.

The records shall be maintained in accordance with Governmental Accounting Standards Board (GASB) Accounting Standards or the Financial Accounting Standards Board (FASB) Accounting Standards Codification, as applicable, and any related AICPA Industry Audit and Accounting guides.

In addition, documentation of grant applications, budgets, reports, awards, and expenditures will be maintained in accordance with U.S. Office of Management and Budget's Uniform Administrative Requirements, Cost Principles, and Audit Requirements for Federal Awards.

Grant expenditures shall be made in accordance with local government purchasing policies and procedures and purchasing procedures for local governments authorized under state law.

The Grantee shall also comply with any recordkeeping and reporting requirements prescribed by the Tennessee Comptroller of the Treasury.

The Grantee shall establish a system of internal controls that utilize the COSO Internal Control - Integrated Framework model as the basic foundation for the internal control system. The Grantee shall incorporate any additional Comptroller of the Treasury directives into its internal control system.

Any other required records or reports which are not contemplated in the above standards shall follow the format designated by the head of the Grantor State Agency, the Central Procurement Office, or the Commissioner of Finance and Administration of the State of Tennessee.

Environmental Tobacco Smoke - Pursuant to the provisions of the federal "Pro-Children Act of 1994" and the "Children's Act for Clean Indoor Air of 1995," Tenn Code Ann. §§39-17-1601 through 1606, the Grantee shall prohibit smoking of tobacco products within any indoor premises in which services are provided to individuals under the age of eighteen (18) years. The Grantee shall post "no smoking" signs in appropriate, permanent sites within such premises. This prohibition shall be applicable during all hours, not just the hours in which children are present. Violators of the prohibition may be subject to civil penalties and fines. This prohibition shall apply to and be made part of any subcontract related to this Grant Contract."

Instructions and Conditions:

By submitting a quote to the City of Knoxville, the submitter warrants the following:

1. The quote is good for 60 days.
2. The Quoter is licensed to conduct business in the City or County where it is headquartered.
3. The Quoter will use environmentally friendly products and services whenever possible.
4. The Quoter has not entered into any collusion with any person in respect to the pricing of this order or any other.
5. The Quoter represents and agrees to the termination clause, and indemnification clause included in this document.

The Quoter, to the best of its knowledge and belief, does not engage in investment activities in Iran and is not on the list created pursuant to T.C.A § 12-12-106 (available at https://www.tn.gov/content/dam/tn/generalservices/documents/cpo/cpo-library/public-information-library/List_of_persons_pursuant_to_Tenn._Code_Ann._12-12-106_Iran_Divestment_Act_updated_7.7.17.pdf)

6. The Quoter shall be responsible for full compliance with all applicable federal, state, and local laws, rules and regulations.

Indemnification Clause - Contractor shall defend, indemnify and hold harmless the City, its officers, employees and agents from any and all liabilities which may accrue against the City, its officers, employees and agents or any third party for any and all lawsuits, claims, demands, losses or damages alleged to have arisen from an act or omission of Contractor in performance of this Agreement or from

Contractor's failure to perform this Agreement using ordinary care and skill, except where such injury, damage, or loss was caused by the sole negligence of the City, its agents or employees.

Contractor shall save, indemnify and hold the City harmless from the cost of the defense of any claim, demand, suit or cause of action made or brought against the City alleging liability referenced above, including, but not limited to, costs, fees, attorney fees, and other expenses of any kind whatsoever arising in connection with the defense of the City; and Contractor shall assume and take over the defense of the City in any such claim, demand, suit, or cause of action upon written notice and demand for same by the City. Contractor will have the right to defend the City with counsel of its choice that is satisfactory to the City, and the City will provide reasonable cooperation in the defense as Contractor may request. Contractor will not consent to the entry of any judgment or enter into any settlement with respect to an indemnified claim without the prior written consent of the City, such consent not to be unreasonably withheld or delayed. The City shall have the right to participate in the defense against the indemnified claims with counsel of its choice at its own expense.

Contractor shall save, indemnify and hold City harmless and pay judgments that shall be rendered in any such actions, suits, claims or demands against City alleging liability referenced above.

The indemnification and hold harmless provisions of this Agreement shall survive termination of the Agreement.

Ethical Standards - Attention of all firms is directed to the following provisions contained in the Code of the City of Knoxville: Chapter 24, Article II, Section 24-33 entitled "Debts owed by persons receiving payments other than Salary;" Chapter 2, Article VIII, Division 11. The Contractor hereby takes notice of and affirms that it is not in violation of, or has not participated, and will not participate, in the violation of any of the following ethical standards prescribed by the Knoxville City Code:

A. Section 2-1048. Conflict of Interest.

It shall be unlawful for any employee of the city to participate, directly or indirectly, through decision, approval, disapproval, recommendation, preparation of any part of a purchase request, influencing the content of any specification or purchase standard, rendering of advice, investigation, auditing or otherwise, in any proceeding or application, request for ruling or other determination, claim or controversy or other matter pertaining to any contract or subcontract and any solicitation or proposal therefore, where to the employee's knowledge there is a financial interest possessed by:

- (1) the employee or the employee's immediate family;
- (2) a business other than a public agency in which the employee or member of the employee's immediate family serves as an officer, director, trustee, partner or employee; or
- (3) any person or business with whom the employee or a member of the employee's immediate family is negotiating or has an arrangement concerning prospective employment.

B. Section 2-1049. Receipt of Benefits from City Contracts by Council Members, Employees and Officers of the City.

It shall be unlawful for any member of council, member of the board of education, officer or employee of the city to have or hold any interest in the profits or emoluments of any contract, job, work or service, either by himself or by another, directly or indirectly. Any such contract for a job, work or service for the city in which any member of council, member of the board of education, officer or employee has or holds any such interest is void.

C. Section 2-1050. Gratuities and Kickbacks Prohibited.

It is unlawful for any person to offer, give or agree to give to any person, while a city employee, or for any person, while a city employee, to solicit, demand, accept or agree to accept from another person, anything of a pecuniary value for or because of:

- (1) An official action taken, or to be taken, or which could be taken;
- (2) A legal duty performed, or to be performed, or which could be performed; or
- (3) A legal duty violated, or to be violated, or which could be violated by such person while a city employee.

Anything of nominal value shall be presumed not to constitute a gratuity under this section.

Kickbacks. It is unlawful for any payment, gratuity, or benefit to be made by or on behalf of a subcontractor or any person associated therewith as an inducement for the award of a subcontract or order.

D. Section 2-1051. Covenant Relating to Contingent Fees.

(a) Representation of Contractor. Every person, before being awarded a contract in excess of ten thousand dollars (\$10,000.00) with the city, shall represent that no other person has been retained to solicit or secure the contract with the city upon an agreement or understanding for a commission, percentage, brokerage or contingent fee, except for bona fide employees or bona fide established commercial, selling agencies maintained by the person so representing for the purpose of securing business.

(b) Intentional Violation Unlawful. The intentional violation of the representation specified in subsection (a) of this section is unlawful.

E. Section 2-1052. Restrictions on Employment of Present and Former City Employees.

Contemporaneous employment prohibited. It shall be unlawful for any city employee to become or be, while such employee, an employee of any party contracting with the particular department or agency in which the person is employed.

For violations of the ethical standards outlined in the Knoxville City Code, the City has the following remedies:

- (1) Oral or written warnings or reprimands;
- (2) Cancellation of transactions; and
- (3) Suspension or debarment from being a Contractor or subcontractor under city or city-funded contracts.

The value of anything transferred in violation of these ethical standards shall be recoverable by the City from such person. All procedures under this section shall be in accord with due process requirements, included but not limited to a right to notice and hearing prior to imposition of any cancellation, suspension or debarment from being a Contractor or subcontractor under a city contract.

Termination - The City may terminate this Agreement at any time, with or without cause, by written notice of termination to the Contractor.

If the City terminates this Agreement, and such termination is not a result of a default by the Contractor, the Contractor shall be entitled to receive as its sole and exclusive remedy the following amounts from the City, and the City shall have no further or other obligations to the Contractor: the amount due to the Contractor for work executed through the date of termination, not including any future fees, profits, or other compensation or payments which the Contractor would have been entitled to receive if this Agreement had not been terminated.

The City may, by written notice of default to the Contractor, terminate the whole or any part of this Agreement if the Contractor fails to perform any provisions of this Agreement and does not cure such failure within a period of ten (10) days (or such longer period as the Purchasing Agent may authorize in writing) after receipt of said notice from the Purchasing Agent specifying such failure. If this Agreement is terminated in whole or in part for default, the City may procure, upon such terms and in such manner as the Purchasing Agent may deem appropriate, supplies or services similar to those terminated.

Please complete the Quote Section and Subcontractor Information Form below and send your written quote to either the email address or fax number shown below:

James McKeehan

Assistant Purchasing Agent

City of Knoxville

jmckeehan@knoxvilletn.gov

FAX: (865) 215-2277

QUOTE SECTION

Having carefully examined the specifications detailed above, we hereby propose to furnish the supervision, labor, materials, equipment, delivery, and services as stated for the following sum:

Quote \$ _____

GUARANTEE of delivery no later than: _____

Legal Name of Proposer: _____

Official Business Address: _____

Telephone Number: _____

Contact Person: _____

Email Address: _____

DUNS # _____ Date Business Established: _____

Gross Annual Receipts (Check One):

- | | | | |
|--|---|--|--|
| <input type="checkbox"/> < \$500,000K | <input type="checkbox"/> \$500,000 - \$1,000,000 | <input type="checkbox"/> \$1,000,000 - \$2,000,000 | |
| <input type="checkbox"/> \$2,000,000 – \$5,000,000 | <input type="checkbox"/> \$5,000,000 – \$10,000,000 | <input type="checkbox"/> > \$10,000,000 | |
| <input type="checkbox"/> > \$25,000,000 | <input type="checkbox"/> > \$50,000,000 | <input type="checkbox"/> > \$75,000,000 | <input type="checkbox"/> > \$100,000,000 |

Signature: _____

Name and Title of Signer: _____

SUBCONTRACTOR INFORMATION FORM

Bidders/Proposers shall provide information requested below for all sub-contractors being utilized if awarded the procurement project being solicited. Note that all fields must be complete. If no sub-contractors are being utilized, indicated such by writing "N/A" within one of the information fields below.

Official Business Name of Sub-Contractor	Contact Information
	Contact Name:
	Phone #:
	Email:
Description of work sub-contractor will perform:	
Dollar amount this sub-contractor's work represents within the bid/proposal:	\$
Office Use Only	DBE (Y/N):

Official Business Name of Sub-Contractor	Contact Information
	Contact Name:
	Phone #:
	Email:
Description of work sub-contractor will perform:	
Dollar amount this sub-contractor's work represents within the bid/proposal:	\$
Office Use Only	DBE (Y/N):