



CITY OF HAVELOCK

Post Office Box 368

Havelock, NC 28532

INVITATION TO BID

Pursuant to North Carolina General Statutes §143-131, the City of Havelock invites informal bids on the following:

Bids must be submitted in accordance with the attached specifications.

Bids can be submitted by mail, email, fax or hand delivered. Cover sheets, envelopes, etc. should be clearly marked with the words:

*“City of Havelock,
Small Pavement Repairs”*

Address Bids to: **Lee Tillman, Director of Finance**
 City of Havelock
 P.O. Box 368
 1 Government Ave.
 Havelock NC 28532
 Fax 252-447-0126
 Email: Ltillman@havelocknc.us

Bids will be accepted until **3:00 p.m. (EST) on Thursday 15 December 2016** at which time they will be reviewed in the office of the City Finance Director. Quotes are not subject to public inspection until the contract is awarded. The bids are good for 75 days after opening.

Bidders are cautioned not to submit bids until the proposed requirements and specifications have been carefully examined. It will be considered that bidders will have satisfied themselves as to the accuracy of the specifications. No proposal will be considered unless prices are submitted for all items requested in any section. The City reserves the right to change the amount of quantities.

The names of certain brands or makes denote quality standard in the article desired, but do not restrict bidders to the specific brand, make or manufacturer named. They are meant to convey to prospective bidders the general style, type, character and quality of the article desired.

The successful bidder on all construction contracts will be required to conduct the operation in accordance with all Federal, State, and Municipal health and safety rules, regulations and laws applicable to the operation. The successful bidder may be asked to provide the City with a copy of the company's safety plan prior to commencing work. For all projects over \$30,000, a general contractor's license must be furnished to the City if applicable.



CITY OF HAVELOCK

Post Office Box 368
Havelock, NC 28532

North Carolina General Statutes, specifically §160A-20.1(b), prohibit the City from entering into contracts with contractors and subcontractors who have not complied with the requirement of Article 2 of Chapter 64. The Contractor shall submit the E-Verify Affidavit, located in the Bid Proposal section, with their bid. Bids that do not include this Affidavit will be considered non-responsive.

N.C.G.S 147-86.55-69 requires certification for bids with a North Carolina Local Government. The certification is required at the time when a bid is submitted.

N.C.G.S 147-86.55-69 requires that contractors with a North Carolina Local Government must not utilize any subcontractor found on the State Treasurer's Final Divestment List.

The State Treasurer's Final Divestment List can be found on the State Treasurer's website at the address www.nctreasurers.com/Iran and will be updated every 180 days.

The City of Havelock reserves the right to reject any or all proposals and to purchase items from the state contract in the efforts to award the contract to the bidder it deems to be for the best interest of the City.

This institution is an equal opportunity provider, and employer.

Contact person(s) for information on this bid:

For questions in regards to the bid specifications, the City requires and only responds to questions submitted in writing and sent via email to:

Ltillman@havelocknc.us **AND cc:** Asmith@havelocknc.us

This is the 6th day of December 2016

CITY OF HAVELOCK

Lee W. Tillman
Finance Director



STATE OF NORTH CAROLINA
AFFIDAVIT
CITY OF HAVELOCK

I, _____ (the individual attesting below), being duly authorized by and on behalf of _____ (the entity hereinafter "Employer") after first being duly sworn hereby swears or affirms as follows:

1. Employer understands that E-Verify is the federal E-Verify program operated by the United States Department of Homeland Security and other federal agencies, or any successor or equivalent program used to verify the work authorization of newly hired employees pursuant to federal law in accordance with NCGS §64-25(5).
2. Employer understands that Employers Must Use E-Verify. Each employer, after hiring an employee to work in the United States, shall verify the work authorization of employee through E-Verify in accordance with NCGS §64-26(a).
3. Employer is a person, business entity, or other organization that transacts business in the State and that employs 25 or more employees in this State. (mark Yes or No)
 - a. YES _____, or
 - b. NO _____
4. Employer's subcontractors comply with E-Verify, and if Employer is the winning bidder on this project Employer will ensure compliance with E-Verify by any subcontractors subsequently hired by Employer.

This _____ day of _____, 20____.

Signature of Affiant
Print or Type Name: _____

State of North Carolina County of _____

Signed and sworn to (or affirmed) before me, this the _____ day of _____, 20____.

|||
(Affix Official/)

Bid Sheet

Pavement Repair 2-inches asphalt in accordance with NCDOT Standard Drawing #654.01 - Saw cutting to have smooth edges, adding stone as needed and paving a minimum of 2 inches of asphalt.	\$ -	per square yard.
Pavement Repair 3-inches asphalt in accordance with NCDOT Standard Drawing #654.01 - Saw cutting to have smooth edges, adding stone as needed and paving a minimum of 3 inches of asphalt.	\$ -	per square yard.
TOTAL	\$ -	per square yard.

Company Name: _____

Company Address: _____

Contact Person: _____

Telephone Number: _____

NC Contractor's License Type and Number: _____

IRAN DIVESTMENT ACT CERTIFICATION

REQUIRED BY N.C.G.S 147-86.55-69

As of the date listed below, the vendor or bidder listed above is not listed on the Final Divestment List created by the State Treasurer pursuant to N.C.G.S. 147-86.55-69.

The undersigned hereby certifies that he or she is authorized by the vendor or bidder listed above to make the forgoing statement.

Authorized Signature: _____

Print Name of Authorized Signature: _____

Title: _____

Address Bid to:

Lee Tillman, Director of Finance
City of Havelock
P.O. Drawer 368
1 Governmental Avenue
Havelock NC 28532

Please indicate the Bid name on the outside of the envelope.



Project Scope:

Repair Utility Cuts in pavements. Typically City of Havelock experiences approximately 100 utility line repairs per year. Each utility repair typically involves a cut in the pavement of approximately 8-ft x 8-ft in dimension. Scope of the work is approximately 725 square yards of asphalt repairs.

Utility Repairs may occur in either City of Havelock streets or NC state roads.

Pavement Repairs in City of Havelock streets require 2-inches of asphalt.

Pavement Repairs in NC state roads require 3-inches of asphalt.

Contractor will be contacted when a minimum of 100 square yards of pavement repairs have accumulated and will be required to mobilize on site within fourteen (14) calendar days when notified.

General Provisions:

1. Contractor shall comply with all requirements of OSHA 1926.
2. Period of Performance is from date of award until 30 June 2017, the end of the City of Havelock's fiscal year.
3. Contractor will obtain all necessary permits. Permits required by City of Havelock are provided free of charge.

Project Specifications:

1. All road repairs shall meet NCDOT standards using NCDOT Standard Drawing #654.01 Pavement Repairs, detail titled "Pavement Repairs on Roads to Be Resurfaced". (*Standard Drawing PDF attached.*)
2. Select fill shall be used in maximum of 12-inch lifts when backfilling the trench that must be compacted with proper equipment to meet NCDOT compaction ratings.
3. All necessary efforts shall be made to control erosion and sediment release while this project is under construction.
4. Repairs to any NC state road will require a Traffic Control Plan that meets or exceeds NCDOT standards.
5. Contractor will be required to prepare and submit a Traffic Control Plan to NCDOT for approval, if required.

Basis of Bid:

1. Bids will consist of two items:
 - a. Unit Price of pavement repair for 2-inches of asphalt.
 - b. Unit Price of pavement repair for 3-inches of asphalt.

Pavement Repair 2-inches asphalt in accordance with NCDOT Standard Drawing #654.01 - Saw cutting to have smooth edges, adding stone as needed and paving a minimum of 2 inches of asphalt.	\$ -	per square yard.
Pavement Repair 3-inches asphalt in accordance with NCDOT Standard Drawing #654.01 - Saw cutting to have smooth edges, adding stone as needed and paving a minimum of 3 inches of asphalt.	\$ -	per square yard.
TOTAL	\$ -	per square yard.

Evaluation of Bids:

Award will be made to the lowest, responsible, and responsive bidder based on the sum total of the two items described above.

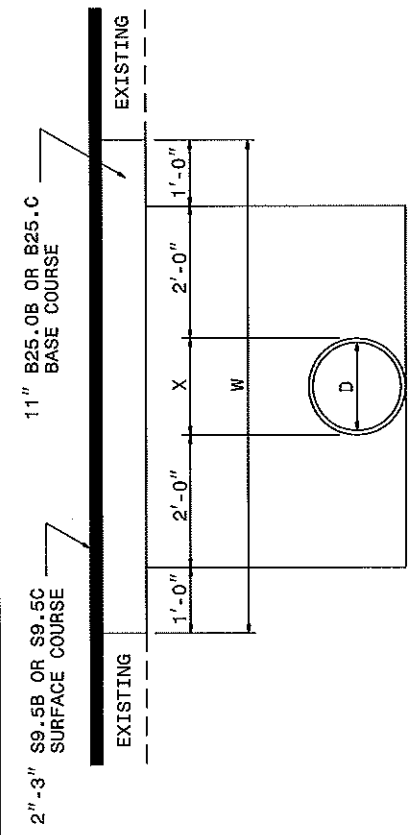

**PAVEMENT REPAIRS ON ROADS TO BE RESURFACED
 (PIPE IS PLACED UNDER EXISTING PAVEMENT)**

D	X	W
12"	1'-4"	7'-4"
15"	1'-7"	7'-7"
18"	1'-10"	7'-10"
24"	2'-6"	8'-6"
30"	3'-1"	9'-1"
36"	3'-8"	9'-8"
42"	4'-5"	10'-5"
48"	5'-0"	11'-0"

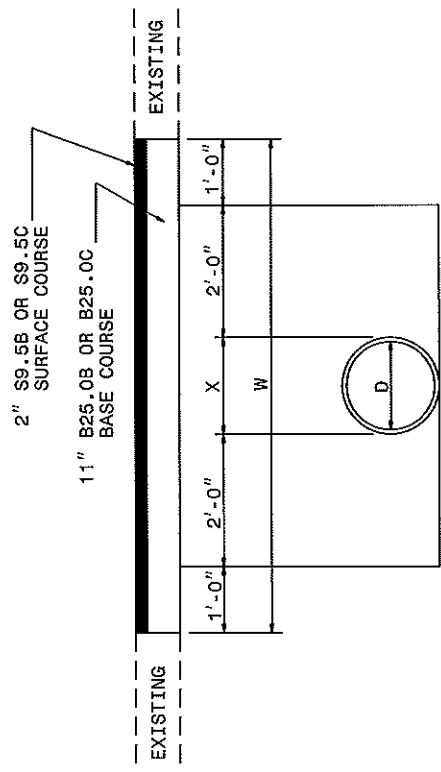

**PAVEMENT REPAIRS ON ROADS NOT TO BE RESURFACED
 (PIPE IS TO BE PLACED UNDER EXISTING PAVEMENT)**