



DEPARTMENT OF REGULATORY AND ECONOMIC RESOURCES (RER)  
BOARD AND CODE ADMINISTRATION DIVISION

**NOTICE OF ACCEPTANCE (NOA)**

MIAMI-DADE COUNTY  
PRODUCT CONTROL SECTION  
11805 SW 26 Street, Room 208  
T (786) 315-2590 F (786) 315-2599  
[www.miamidade.gov/economy](http://www.miamidade.gov/economy)

**WinDoor, Inc.**  
7500 Amsterdam Drive  
Orlando, FL 32832

**SCOPE:**

This NOA is being issued under the applicable rules and regulations governing the use of construction materials. The documentation submitted has been reviewed and accepted by Miami-Dade County RER - Product Control Section to be used in Miami-Dade County and other areas where allowed by the Authority Having Jurisdiction (AHJ).

This NOA shall not be valid after the expiration date stated below. The Miami-Dade County Product Control Section (In Miami-Dade County) and/or the AHJ (in areas other than Miami-Dade County) reserve the right to have this product or material tested for quality assurance purposes. If this product or material fails to perform in the accepted manner, the manufacturer will incur the expense of such testing and the AHJ may immediately revoke, modify, or suspend the use of such product or material within their jurisdiction. RER reserves the right to revoke this acceptance, if it is determined by Miami-Dade County Product Control Section that this product or material fails to meet the requirements of the applicable building code.

This product is approved as described herein, and has been designed to comply with the Florida Building Code, including the High Velocity Hurricane Zone.

**DESCRIPTION: Series "360" Aluminum Single Hung Window – L.M.I.**

**APPROVAL DOCUMENT:** Drawing No. SH360LM-NOA (former 18-90D), titled Series "360" Alum Single Hung WDW. (L.M.I./S.M.I.), sheets 1 through 14 of 14, dated 02/10/20, prepared by manufacturer, signed and sealed by Lynn Miller, P.E., bearing the Miami-Dade County Product Control Renewal stamp with the Notice of Acceptance number and expiration date by the Miami-Dade County Product Control Section.

**MISSILE IMPACT RATING: Large and Small Missile Impact Resistant.**

**LABELING:** Each unit shall bear a permanent label with the manufacturer's name or logo, city, state, model/series, and following statement: "Miami-Dade County Product Control Approved", unless otherwise noted herein.

**RENEWAL** of this NOA shall be considered after a renewal application has been filed and there has been no change in the applicable building code negatively affecting the performance of this product.

**TERMINATION** of this NOA will occur after the expiration date or if there has been a revision or change in the materials, use, and/or manufacture of the product or process. Misuse of this NOA as an endorsement of any product, for sales, advertising or any other purposes shall automatically terminate this NOA. Failure to comply with any section of this NOA shall be cause for termination and removal of NOA.

**ADVERTISEMENT:** The NOA number preceded by the words Miami-Dade County, Florida, and followed by the expiration date may be displayed in advertising literature. If any portion of the NOA is displayed, then it shall be done in its entirety.

**INSPECTION:** A copy of this entire NOA shall be provided to the user by the manufacturer or its distributors and shall be available for inspection at the job site at the request of the Building Official.

This NOA renews # 18-1001.19 PLA consists of this page 1 and evidence pages E-1, E-2 and E-3, as well as approval document mentioned above.

The submitted documentation was reviewed by Ishaq I. Chanda, P.E.



2/27/20

NOA No. 20-0213.05  
Expiration Date: May 05, 2025  
Approval Date: March 05, 2020  
Page 1

**NOTICE OF ACCEPTANCE: EVIDENCE SUBMITTED**

**1. EVIDENCE SUBMITTED UNDER PREVIOUS NOA(s)**

**A. DRAWINGS**

1. Manufacturer's die drawings and sections (*See NOA #17-1018.06*)
2. Drawing No. **18-90D**, titled Series "360" Alum Single Hung Wdw. (L.M.I./S.M.I.), sheets 1, 1A, 2, 2A, 3, 3A, 4, 4A and 5 through 10 of 10, dated 01/28/05, prepared by Al-Farooq Corporation, signed and sealed by Javad Ahmad, P.E.

**B. TESTS (*Submitted under NOA #17-1018.06*)**

1. Test reports on: 1) Uniform Static Air Pressure Test, Loading per FBC TAS 202-94  
2) Large Missile Impact Test per FBC, TAS 201-94  
3) Cyclic Wind Pressure Loading per FBC, TAS 203-94  
along with marked-up drawings and installation diagram of a series 7500 PVC fixed window, to qualify DuPont "Butacite" PVB interlayer, Duraseal® and Super Spacer® insulating glass spacer, prepared by Certified Test Laboratories, Test Report No. **CTLA-3056 WA**, dated 03/03/15, signed and sealed by Ramesh C. Patel, P.E.  
*(Submitted under NOA No. 15-0512.07)*
2. Test reports on: 1) Uniform Static Air Pressure Test, Loading per FBC TAS 202-94  
2) Large Missile Impact Test per FBC, TAS 201-94  
3) Cyclic Wind Pressure Loading per FBC, TAS 203-94  
along with marked-up drawings and installation diagram of a series 7400 PVC project out window, to qualify DuPont "Butacite" PVB interlayer, Duraseal® and Super Spacer® insulating glass spacer, prepared by Certified Test Laboratories, Test Report No. **CTLA-3056 WB**, dated 03/03/15, signed and sealed by Ramesh C. Patel, P.E.  
*(Submitted under NOA No. 15-0512.07)*
3. Test reports on: 1) Uniform Static Air Pressure Test, Loading per FBC TAS 202-94  
2) Large Missile Impact Test per FBC, TAS 201-94  
3) Cyclic Wind Pressure Loading per FBC, TAS 203-94  
along with marked-up drawings and installation diagram of a series 238 aluminum fixed window, to qualify DuPont "Butacite" PVB interlayer, Duraseal® and Super Spacer® insulating glass spacer, prepared by Certified Test Laboratories, Test Report No. **CTLA-3056 WC**, dated 04/16/15, signed and sealed by Ramesh C. Patel, P.E.  
*(Submitted under NOA No. 15-0512.07)*
4. Test reports on: 1) Air Infiltration Test, per FBC, TAS 202-94  
2) Uniform Static Air Pressure Test, Loading per FBC TAS 202-94  
3) Water Resistance Test, per FBC, TAS 202-94  
4) Large Missile Impact Test per FBC, TAS 201-94  
5) Small Missile Impact Test per FBC, TAS 201-94  
6) Cyclic Wind Pressure Loading per FBC, TAS 203-94  
7) Forced Entry Test, Type "A-A" vertical sliding window, Grade 10, per FBC 2411 3.2.1, TAS 202-94, per ASTM F 588-04, AAMA 1302.5-04 and CAWM 301-04.

  
\_\_\_\_\_  
Ishaq I. Chanda, P.E.  
Product Control Unit Supervisor  
NOA No. 20-0213.05  
Expiration Date: May 05, 2025  
Approval Date: March 05, 2020

NOTICE OF ACCEPTANCE: EVIDENCE SUBMITTED

**B. TESTS (CONTINUED)**

4. along with marked-up drawings and installation diagram of an aluminum single hung window, prepared by Hurricane Test Laboratory, LLC, Test Report No. **HTL-0080-0402-08, specimens 1, 2, 3 and 4**, dated 04/03/08 to 07/22/08, signed and sealed by Vinu J. Abraham, P.E. (*Submitted under NOA No. 08-1208.06*)
5. Test reports on:
  - 1) Air Infiltration Test, per FBC, TAS 202-94
  - 2) Uniform Static Air Pressure Test, Loading per FBC TAS 202-94
  - 3) Water Resistance Test, per FBC, TAS 202-94
  - 4) Small Missile Impact Test per FBC, TAS 201-94
  - 5) Cyclic Wind Pressure Loading per FBC, TAS 203-94
  - 6) Forced Entry Test, Type "A-A" vertical sliding window, Grade 10, per FBC 2411 3.2.1, TAS 202-94, per ASTM F 588-04, AAMA 1302.5-04 and CAWM 301-04along with marked-up drawings and installation diagram of an aluminum single hung window, prepared by Hurricane Test Laboratory, LLC, Test Report No. **HTL-0080-0323-04, specimens 1, 2, 3, 4, 5, 6, 7 and 9**, dated 03/29/04 to 04/02/04, signed and sealed by Vinu J. Abraham, P.E. (*Submitted under NOA No. 05-0215.02*)

**C. CALCULATIONS**

1. Anchor verification calculations and structural analysis, complying with **FBC 6<sup>th</sup> Edition (2017)**, dated 08/30/17 and revised on 12/12/17, prepared by Al-Farooq Corporation, signed and sealed by Javad Ahmad, P.E.
2. Glazing complies with **ASTM E1300-09**.

**D. QUALITY ASSURANCE**

1. Miami-Dade Department of Regulatory and Economic Resources (RER).

**E. MATERIAL CERTIFICATIONS (See NOA #17-1018.06)**

**F. STATEMENTS**

1. Statement letter of conformance, complying with **FBC 5<sup>th</sup> Edition (2014)**, with **FBC 6<sup>th</sup> Edition (2017)** and of no financial interest, dated August 30, 2017, issued by Al-Farooq Corporation, signed and sealed by Javad Ahmad, P.E.
2. Private labeling agreement between WinDoor, Inc. and CGI Windows and Doors, Inc. document in conformance of RER guideline dated 09/12/2018

**G. OTHERS**

1. Notice of Acceptance No. **17-1018.06**, issued to CGI Windows & Doors for their Series "360" Aluminum Single Hung Window – L.M.I., expiring on 05/05/20.

  
Ishaq I. Chanda, P.E.  
Product Control Unit Supervisor  
NOA No. 20-0213.05  
Expiration Date: May 05, 2025  
Approval Date: March 05, 2020

NOTICE OF ACCEPTANCE: EVIDENCE SUBMITTED

**2. NEW EVIDENCE SUBMITTED**

**A. DRAWINGS**

1. Drawing No. **SH360LM-NOA** (former **18-90D**), titled Series “360” Alum Single Hung WDW. (L.M.I./S.M.I.), sheets 1 through 14 of 14, dated 02/10/20, prepared by manufacturer, signed and sealed by Lynn Miller, P.E.

**B. TESTS (Submitted under NOA #17-1018.06)**

1. None.

**C. CALCULATIONS (Submitted under NOA # 17-1018.06)**

1. None.

**D. QUALITY ASSURANCE**

1. Miami-Dade Department of Regulatory and Economic Resources (RER).

**E. MATERIAL CERTIFICATIONS**

1. Notice of Acceptance No. **17-0808.02** issued to **Kuraray America, Inc.** for their “**SentryGlas® (Clear and White) Glass Interlayers**”, expiring on 07/04/23.
2. Notice of Acceptance No. **18-0301.06** issued to **Eastman Chemical Company (MA)** for their “**Saflex CP – Saflex and Saflex HP Composite Glass Interlayers with PET Core**”, expiring on 12/11/23.
3. Notice of Acceptance No. **17-0712.05** issued to **Eastman Chemical Company (MA)** for their “**Saflex HP Clear or Color Glass Interlayers**”, expiring on 05/21/21.

**F. STATEMENTS**

1. Statement letter of conformance with **FBC 6<sup>th</sup> Edition (2017)** and of no financial interest, dated February 10, 2020, issued by WinDoor Inc., signed and sealed by Lynn Miller, P.E.
2. Statement letter dated 02/10/20 of Successor Professional Engineer adopting as his own the work of another Engineer per FLA chapter 61G15-27.001 and taking full responsibility, signed and sealed by Lynn Miller, P.E.

**G. OTHERS**

1. This NOA **renews # 18-1001.19 PLA**, expiring 05/05/25.
2. Private Labeling Agreement document dated 09/05/18 between CGI and WinDoor in conformance to Product Control guidelines, both signed by Dean M. Ruark, P.E. (Submitted under NOA # **18-1001.19**)

  
Ishaq I. Chanda, P.E.  
Product Control Unit Supervisor  
NOA No. 20-0213.05  
Expiration Date: May 05, 2025  
Approval Date: March 05, 2020

General Window Sections

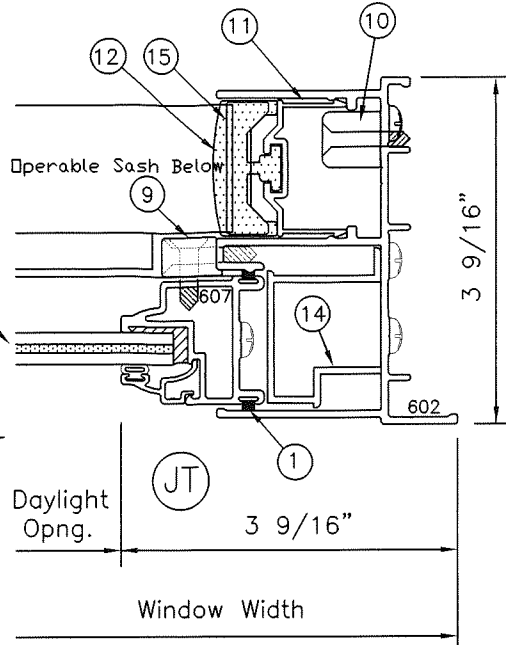
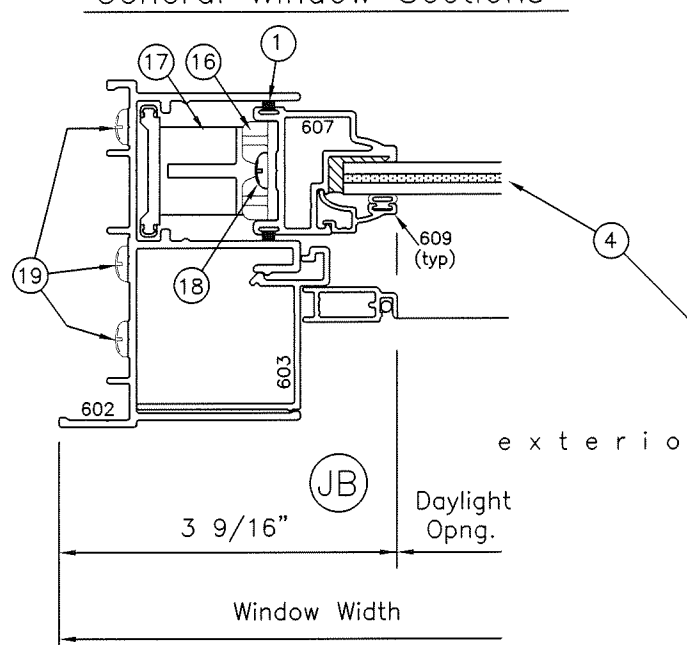
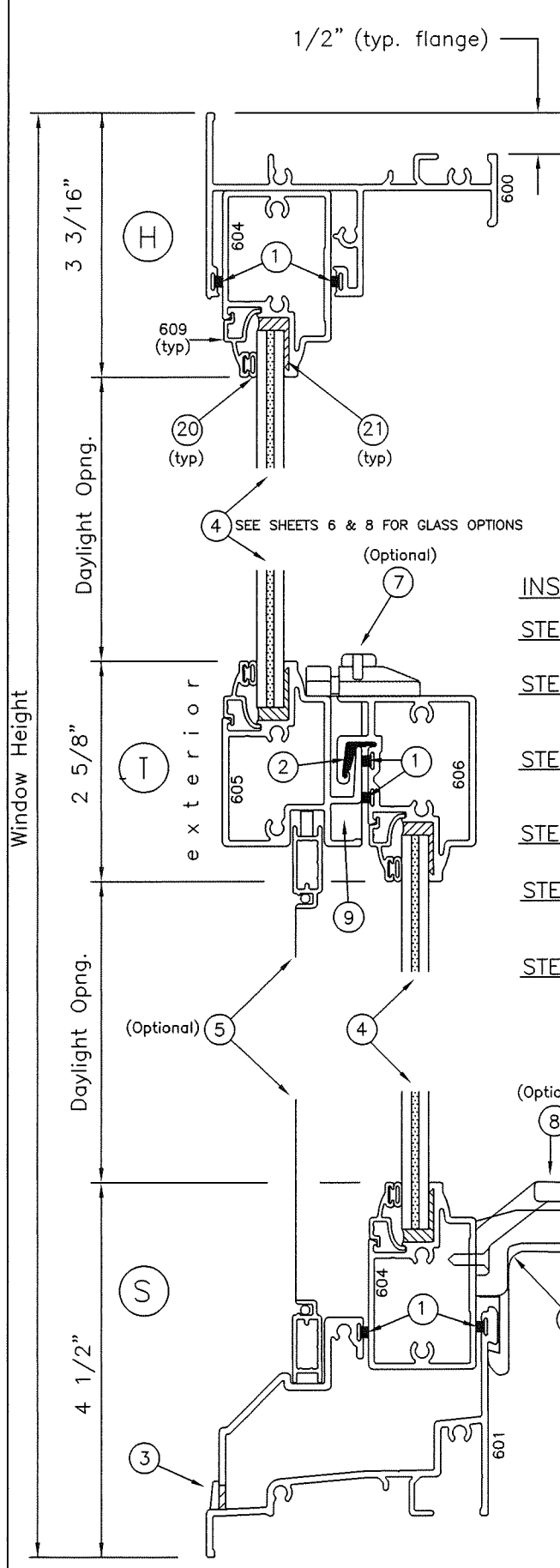

FRAME AND VENT DETAILS FOR GLASS TYPES 1 & 2. SEE SHEETS 5 & 7 FOR CAPACITIES.

THESE WINDOWS ARE RATED FOR LARGE & SMALL MISSILE IMPACT. SHUTTERS ARE NOT REQUIRED.

Installation Screws (Refer to sheets 9, 10 & 11 for spacing information)

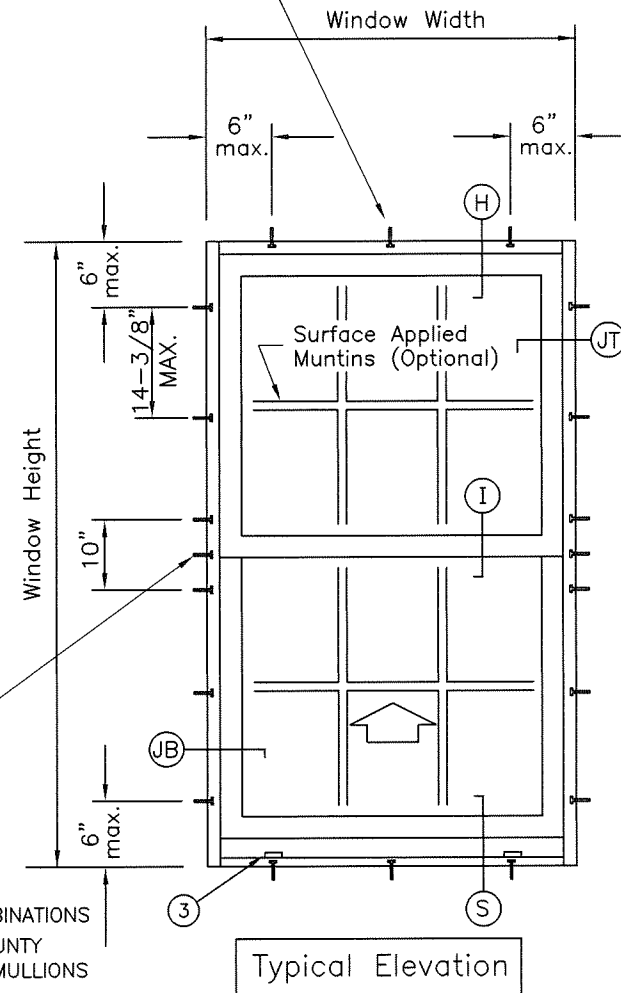

Addl. Anchor At Mtg. Stile Ends Reqd. For Higher Loads (if Applicable) See Chart On Sheet 11 For Capacity

INSTRUCTIONS FOR USING CAPACITY CHARTS:

- STEP 1 DETERMINE THE REQUIRED DESIGN PRESSURES FOR A GIVEN WINDOW OPENING.
  - STEP 2 DETERMINE THE CAPACITY OF THE WINDOW SIZE/CONFIGURATION/GLASS TYPE FROM CHARTS ON SHEETS 5 AND 7.
  - STEP 3 DETERMINE THE ANCHOR CAPACITY FROM SHEET 11 FOR SINGLE OPENINGS, APPLICABLE TO ANCHORS TYPE A, B OR C SHOWN ON SHEETS 9 AND 10.
  - STEP 4 IF ALUMINUM BUCKS ARE USED, VERIFY THE BUCK INSTALLATION CAPACITY FROM SHEET 13.
  - STEP 5 FOR UNCLIPPED MULLED WINDOWS DETERMINE MULLION/MULLION ANCHORS CAPACITY FOR 1X4 TUBE MULLION FROM CHARTS ON SHEET 12.
  - STEP 6 IF ALUMINUM BUCKS ARE USED DETERMINE BUCK ANCHORING REQUIREMENTS FROM CHARTS ON SHEET 14.
- THE LOWEST SELECTED VALUE APPLY TO THE INSTALLATION AND MUST EQUAL OR EXCEED THE REQUIRED DESIGN PRESSURES OBTAINED FROM STEP 1.

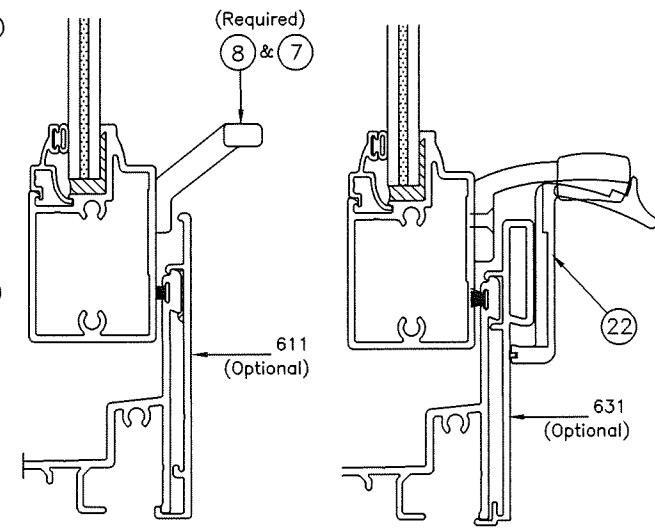

Standard 12 Psf Sill

Optional 15 PSF Water Bar Adaptors

Can not be used with lock type 6

SERIES '360' ALUMINUM SINGLE HUNG WINDOW

APPROVAL APPLIES TO SINGLE UNITS OR SIDE BY SIDE COMBINATIONS OF S.H./S.H. OR SINGLE HUNG WITH OTHER MIAMI-DADE COUNTY APPROVED WINDOWS USING MIAMI-DADE COUNTY APPROVED MULLIONS IN BETWEEN. LOWER DESIGN PRESSURE FROM WINDOWS OR MULLION APPROVAL WILL APPLY TO ENTIRE SYSTEM.

THIS PRODUCT HAS BEEN DESIGNED AND TESTED TO COMPLY WITH THE REQUIREMENTS OF THE 2014 (5TH EDITION)/2017 (6TH EDITION) FLORIDA BUILDING CODE INCLUDING HIGH VELOCITY HURRICANE ZONE (HVHZ).

1BY OR 2BY WOOD BUCKS & BUCK FASTENERS BY OTHERS, MUST BE DESIGNED AND INSTALLED ADEQUATELY TO TRANSFER APPLIED PRODUCT LOADS TO THE BUILDING STRUCTURE

ANCHORS SHALL BE CORROSION RESISTANT, SPACED AS SHOWN ON DETAILS AND INSTALLED PER MANUF'S INSTRUCTIONS. SPECIFIED EMBEDMENT TO BASE MATERIAL SHALL BE BEYOND WALL DRESSING OR STUCCO.

A LOAD DURATION INCREASE IS USED IN DESIGN OF ANCHORS INTO WOOD ONLY. ALL SHIMS TO BE HIGH IMPACT, NON-METALLIC AND NON-COMPRESSIBLE.

MATERIALS INCLUDING BUT NOT LIMITED TO STEEL/METAL SCREWS, THAT COME INTO CONTACT WITH OTHER DISSIMILAR MATERIALS SHALL MEET THE REQUIREMENTS OF THE 2014/2017 FLORIDA BLDG. CODE & ADOPTED STANDARDS.

THIS PRODUCT APPROVAL IS GENERIC AND DOES NOT PROVIDE INFORMATION FOR A SITE SPECIFIC PROJECT, I.E. LIFE SAFETY OF THIS PRODUCT, ADEQUACY OF STRUCTURE RECEIVING THIS PRODUCT AND SEALING AROUND OPENING FOR WATER INFILTRATION RESISTANCE ETC. CONDITIONS NOT SHOWN IN THIS DRAWING ARE TO BE ANALYZED SEPARATELY, AND TO BE REVIEWED BY BUILDING OFFICIAL

PRODUCT RENEWED as complying with the Florida Building Code Acceptance No 26-0213-05 Expiration Date MAY 05, 2025 By Ishay J. Chandr Miami Dade Product Control

PREPARED BY A. LYNN MILLER 1070 TECHNOLOGY DRIVE N. VENICE, FL 34275 (941) 480-1600 REGISTRATION #29296		Date: 2/10/2020 Drawn By: ALAN KINNE DWG No.: SH360LM-NOA
<b>WINDOOR</b> INCORPORATED 7500 AMSTERDAM DRIVE ORLANDO, FL 32832 (407) 481-8400	SERIES "360" ALUM SINGLE HUNG WDW (LMI/SMI)	SHEET 1 OF 14
SECTIONS/INSTRUCTIONS		Rev.
SH360		SH360LM-NOA

ANTHONY LYNN MILLER  
 LICENSE  
 No. 58705  
 2/10/20  
 STATE OF FLORIDA  
 PROFESSIONAL ENGINEER  
 A. LYNN MILLER, P.E.  
 P.E.# 58705

FRAME AND VENT DETAILS FOR GLASS TYPES 3, 3A, 4 AND 4A.  
 SEE SHEETS 6 & 8 FOR CAPACITIES.  
 OPTIONAL TOP RAIL SWEEP LOCK NOT AVAILABLE WITH THESE  
 GLASS TYPES.

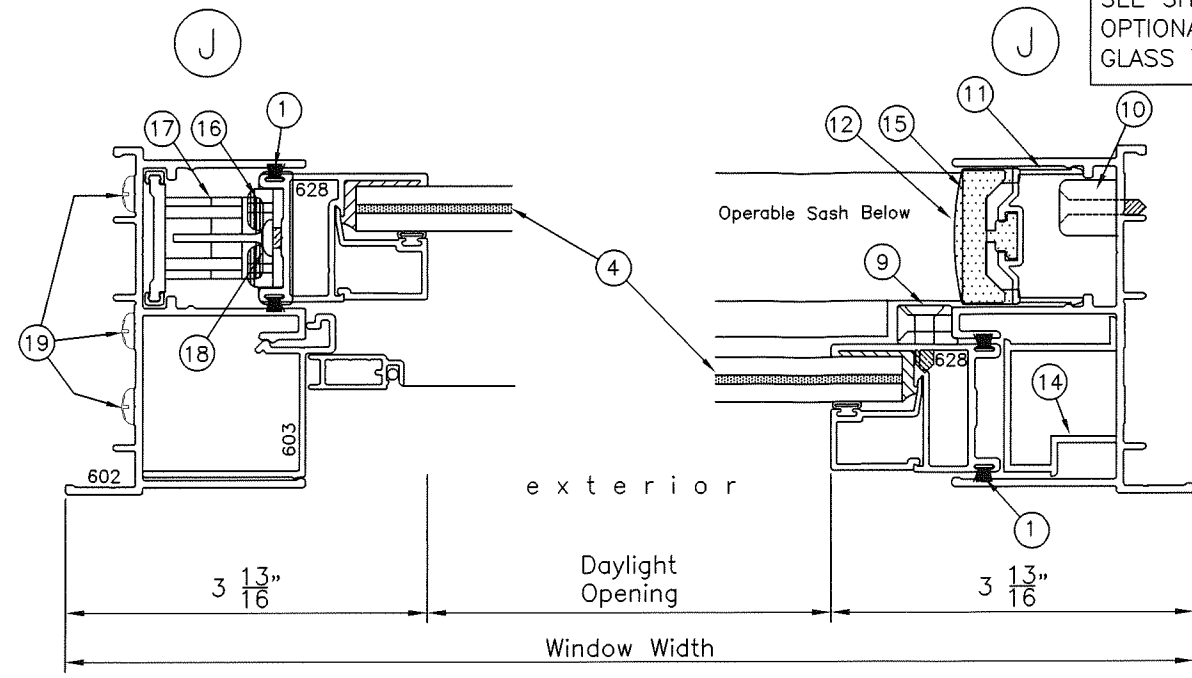
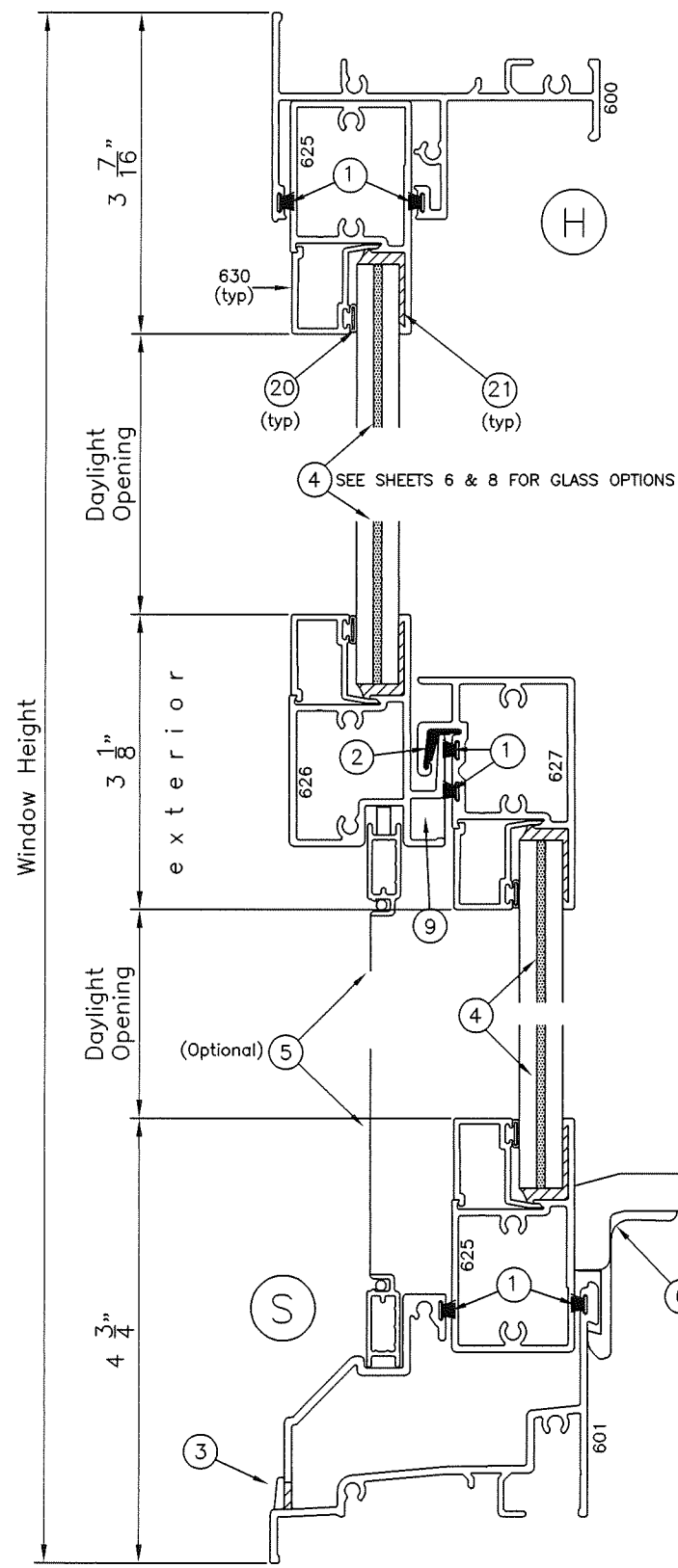

Installation Screws  
 (Refer to sheets  
 9, 10 & 11 for  
 spacing information)

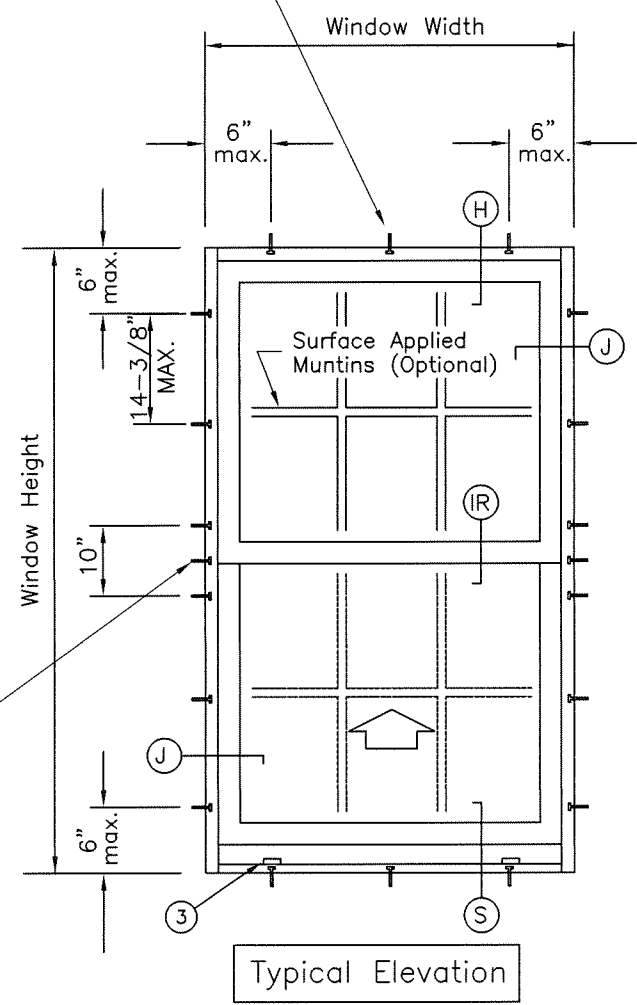

Addl. Anchor  
 At Mtg. Stile Ends  
 Req'd. For Higher Loads  
 (if Applicable)  
 See Chart On Sheet 11  
 For Capacity

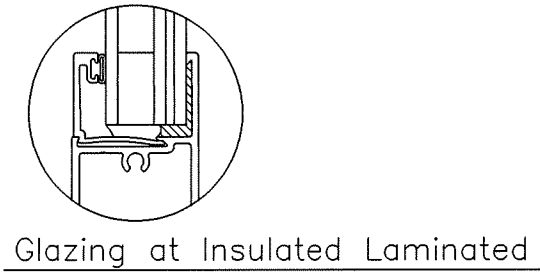

Standard 12 Psf Sill

Optional 15 PSF Water Bar Adaptor  
 Can not be used with lock type ⑥

Revision:

PREPARED BY A. LYNN MILLER 1070 TECHNOLOGY DRIVE N. VENICE, FL 34275 (941) 480-1600		REGISTRATION #29296	Date	2/10/2020
<b>WINDOOR</b> INCORPORATED 7500 AMSTERDAM DRIVE ORLANDO, FL 32832 (407) 481-8400	SERIES "360" ALUM SINGLE HUNG WDW (LMI/SMI)	SECTIONS	By	ALAN KINNE
			DWG No.	SH360LM-NOA
			Sheet	2 OF 14
			Rev.	

PRODUCT RENEWED  
 as complying with the Florida  
 Building Code  
 Acceptance No. 20-0213-05  
 Expiration Date 5/31/25  
 By *Anthony L. Miller*  
 Miami Dade Product Control

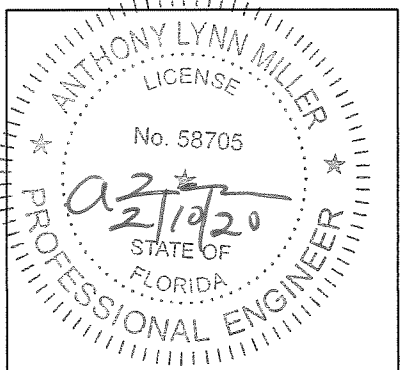

A. LYNN MILLER, P.E.  
 P.E.# 58705

# Bill of Materials

ITEM	PART #	QUANTITY	DESCRIPTION	MATERIAL	MANF./SUPPLIER	REMARKS
1	W23201NG	AS REQD.	WOOL PILE WITH CENTER SOFT FIN (GRAY)	PILE	ULTRAFAB/SCHLEGEL	
2	CGI-612P	AS REQD.	PLASTIC BUMPER GUIDE	PVC	PROTOTYPE PLASTIC EXTRUSIONS	CONTINUOUS AT INTERLOCK
3	#146-4	2	WEEP HOLE COVER	NYLON	BUILDERS PLASTIC COMPANY	
4	N/A	AS REQD.	GLAZING	GLASS	VARIES	
5	N/A	1	COMPLETE SCREEN	ALUM/MESH		
6	CGI-615C & 616C	1 OR 2	COMBINATION EGRESS LOCK AND LIFT/PULL ATTACHED W/(2) #8 X 5/8" FH SMS	ZINC	CUSTOM CASTING	1 @ WDWS. 28" WIDE & SMALLER 2 @ WDWS. OVER 28" WIDE
7	A30700 & C30705	1 OR 2	OPTIONAL SWEEP LOCK & KEEPER (replaces item 6) ATTACHED W/(4) #6 X 5/8" FH SMS	ZINC	TRUTH HARDWARE OR EQUIV.	1 @ WDWS. 28" WIDE & SMALLER 2 @ WDWS. OVER 28" WIDE
8	18-11-XX-100	1 OR 2	LIFT/PULL	ZINC	TRUTH HARDWARE OF EQUIV.	1 @ WDWS. 28" WIDE & SMALLER 2 @ WDWS. OVER 28" WIDE
9	CGI-614C	2	TIE DOWN BLOCK	ZINC	CUSTOM CASTING	
10	VARIES	2	BALANCES (B&T OR SPIRAL)	VARIES	VARIES	BOTH BALANCES CAN BE USED
11	CGI-617P	2	BALANCE COVER	PVC	PROTOTYPE PLASTIC EXTRUSIONS	LOCATED AT TOP HALF OF EACH JAMB
12	CGI-618P	2	VENT STOP	PVC	PROTOTYPE PLASTIC EXTRUSIONS	LOCATED AT TOP OF JAMBS
14	CGI-613P	2	FIXED VENT SHIM	PVC	PROTOTYPE PLASTIC EXTRUSIONS	LOCATED AT TOP OF FIXED VENT
15	CGI-619P	2	TOP GUIDE AT OPERABLE VENT	NYLON	CUSTOM CASTING	
16	CGI-622N	2	BOTTOM GUIDE/CLIP AT OPERABLE VENT	NYLON	CUSTOM CASTING	
17	CGI-620C & 621N	2	CARRIER SYSTEM	ZINC	CUSTOM CASTING	OPTIONAL - BALANCE ATTACHES TO IT
18	N/A	16	VENT ASSEMBLY SCREWS	S/S	VARIES	#10 X 1 1/4" PH SMS (2 PER CORNER)
19	N/A	12	FRAME ASSEMBLY SCREWS	S/S	VARIES	#10 X 1 1/4" PH SMS (2 PER CORNER)
20	CGI-382V	AS REQD.	VINYL BULB	PVC	PROTOTYPE PLASTIC EXTRUSIONS	
21	VARIES	AS REQD.	STUCTURAL SILICONE	SILICONE	3 SILICONES	GE-1200, GE-2000, & DOW 995
22	CGI-632	1 OR 2	COMBINATION EGRESS WB LOCK & LIFT/PULL ATTACHED W/(2) #8 X 5/8" FH SMS	ZINC	CUSTOM CASTING (FOR USE WITH WATERBAR)	1 @ WDWS. 28" WIDE & SMALLER 2 @ WDWS. OVER 28" WIDE
23	-	2/ LITE	SETTING BLOCKS	EPDM	-	DUROMETER 85±5 SHORE A

**PRODUCT RENEWED**  
 as complying with the Florida  
 Building Code  
 Acceptance No. 20-0213-05  
 Expiration Date 5/15/25  
 By Ischay L. Chandra  
 Miami Dade Product Control

Revision:

PREPARED BY A. LYNN MILLER 1070 TECHNOLOGY DRIVE N. VENICE, FL 34275 (941) 480-1600 REGISTRATION #29296	Date	2/10/2020
	By	ALAN KINNE
<b>WINDOOR</b> INCORPORATED 7500 AMSTERDAM DRIVE ORLANDO, FL 32832 (407) 481-8400	DWG No.	SH360LM-NOA
	Sheet	3 OF 14
SERIES "360" ALUM SINGLE HUNG WDW (LM/SMI)		BILL OF MATERIALS SH360

A. LYNN MILLER, P.E.  
 P.E.# 58705

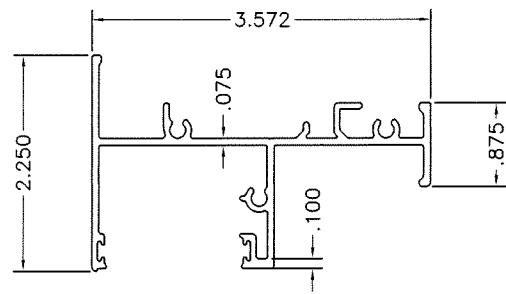

600-Frame Head  
6063-T6

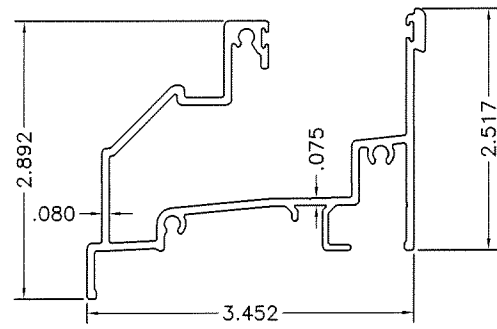

601-Frame Sill  
6063-T6

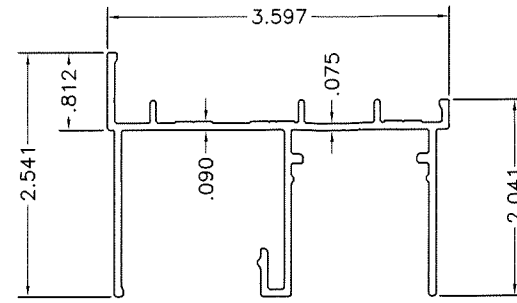

602-Frame Jamb  
6063-T6

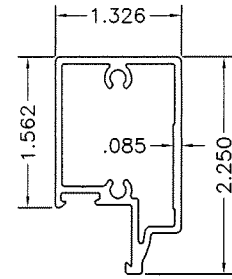

604-Horiz. Rail  
6063-T6

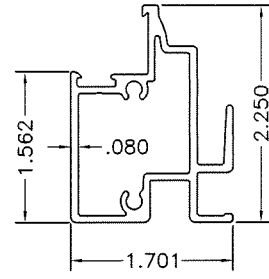

605-Fixed Intlck.  
6063-T6

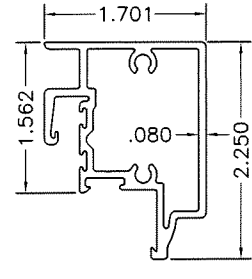

606-Moving Intlck.  
6063-T6

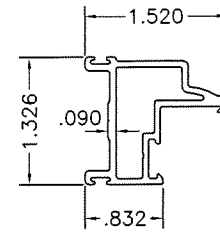

607-Side Rail  
6063-T6

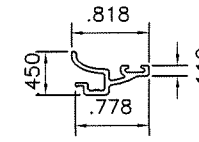

609-Glzg. Bead  
6063-T5

VENT SHAPES FOR GLASS TYPES 1 & 2

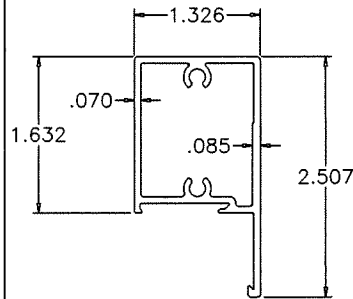

625-Horiz. Rail  
6063-T6

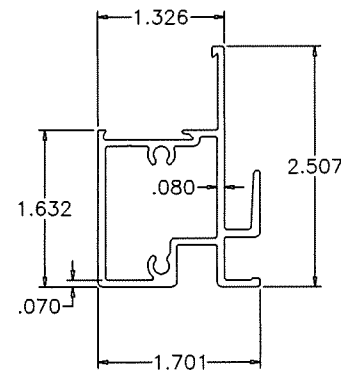

626-Fixed Intlck.  
6063-T6

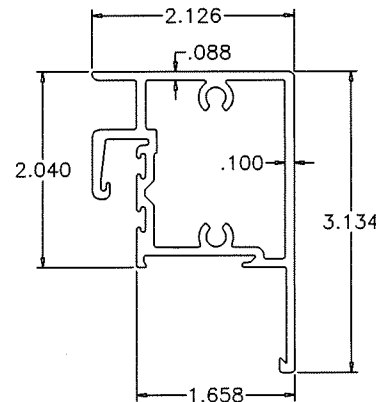

627-Moving Intlck.  
6063-T6

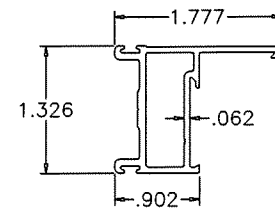

628-Side Rail  
6063-T6

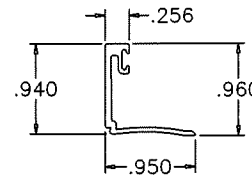

629-Glzg. Bead  
6063-T6  
For Glass Types 4 & 4A

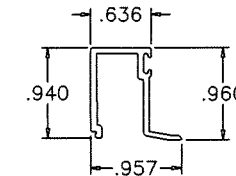

630-Glzg. Bead  
6063-T6  
For Glass Types 3 & 3A

VENT SHAPES FOR GLASS TYPES 3, 3A, 4 & 4A

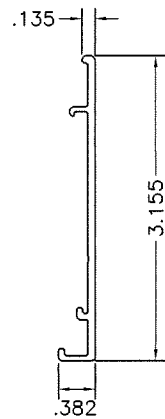

611-Waterbar  
6063-T5

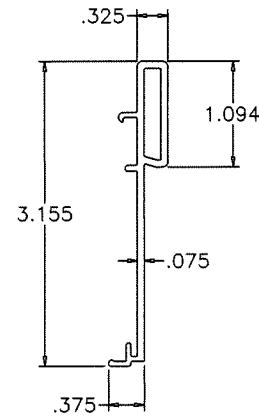

631-Waterbar  
6063-T5

Revision:

PREPARED BY A. LYNN MILLER 1070 TECHNOLOGY DRIVE N. VENICE, FL 34275 (941) 480-1600 REGISTRATION #29296	Date	2/10/2020	Rev.	
	Drawn By	ALAN KINNE	DWG No.	SH360LM-NOA
<b>WINDOOR</b> INCORPORATED 7500 AMSTERDAM DRIVE ORLANDO, FL 32832 (407) 481-8400	Series	SH360	Sheet	4 OF 14
	Desc.	EXTRUSIONS		

PRODUCT RENEWED  
as complying with the Florida  
Building Code  
Acceptance No. 20-0213-05  
Expiration Date 5/1/2025  
By: [Signature]  
Miami Dade Product Control

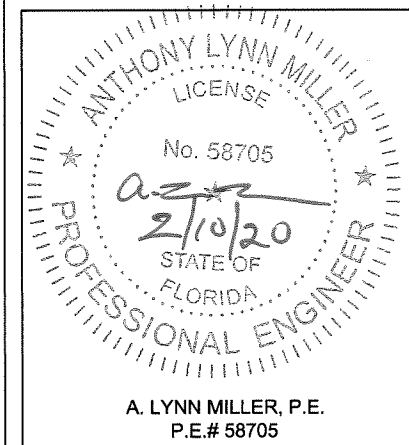

A. LYNN MILLER, P.E.  
P.E.# 58705



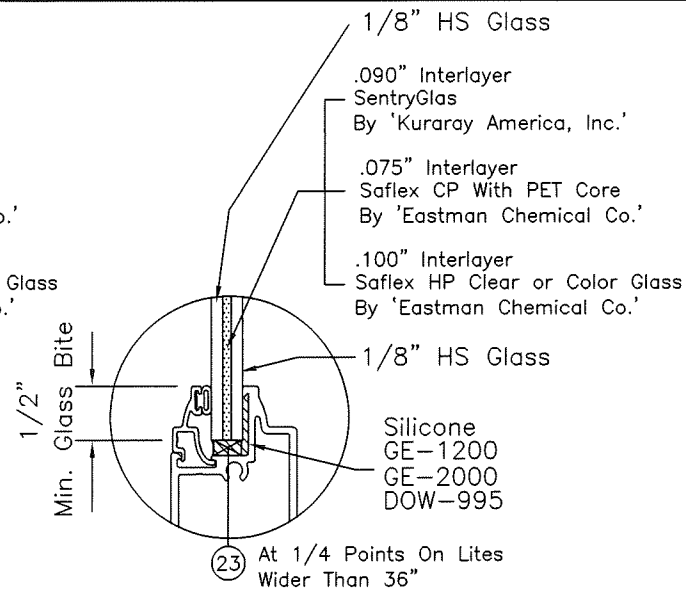
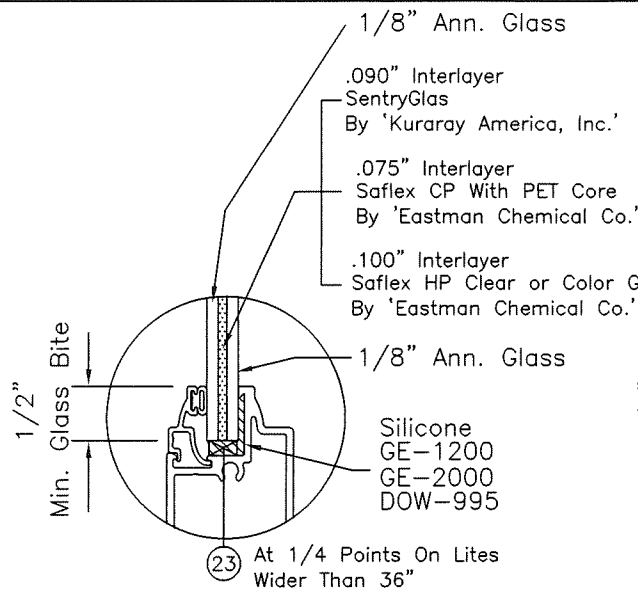

**Glass Type "1"**  
5/16" Nominal Glass  
Annealed/Annealed

**Glass Type "2"**  
5/16" Nominal Glass  
HS/HS

Supplemental Test Results for:  
Air Infiltration – Water Leakage Resistance – Forced Entry

Test Type and Method	Results
Air Infiltration Test (ASTM-E283) @ 1.57 psf pressure differential @ 6.24 psf pressure differential	PASSED ( .044 C.F. / Min / Sq Ft ) PASSED ( .076 C.F. / Min / Sq Ft )
Water Leakage Test (ASTM-E331) without waterbar adaptor with waterbar adaptor	No leakage allowed PASSED @ 12.0 PSF PASSED @ 15.0 PSF
Forced Entry Resistance test (ASTM F588 & Grade 10)	PASSED

EQUAL LITES WINDOWS					
DESIGN LOAD CAPACITY - PSF					
WINDOW DIMS.		GLASS TYPE '1'		GLASS TYPE '2'	
WIDTH	HEIGHT	EXT.(+)	INT.(-)	EXT.(+)	INT.(-)
24"	48"	100.0	210.0	100.0	210.0
30"		100.0	210.0	100.0	210.0
32"		100.0	210.0	100.0	210.0
36"		100.0	180.0	100.0	210.0
42"		100.0	144.0	100.0	210.0
48"		100.0	120.0	100.0	200.0
54"	100.0	102.9	100.0	171.4	
24"	60"	100.0	210.0	100.0	210.0
30"		100.0	199.7	100.0	210.0
32"		100.0	190.3	100.0	210.0
36"		100.0	164.3	100.0	210.0
42"		100.0	128.0	100.0	210.0
48"		100.0	104.7	100.0	120.0
54"	88.6	88.6	100.0	120.0	
24"	72"	100.0	201.1	100.0	210.0
30"		100.0	162.1	100.0	210.0
32"		100.0	167.6	100.0	210.0
36"		100.0	150.7	100.0	210.0
42"		100.0	120.0	100.0	120.0
48"		96.0	96.0	100.0	120.0
54"	80.0	80.0	100.0	120.0	
24"	84"	100.0	179.1	100.0	210.0
30"		100.0	143.4	100.0	210.0
32"		100.0	135.3	100.0	210.0
36"		100.0	120.0	100.0	120.0
42"		100.0	106.1	100.0	120.0
48"		85.6	85.6	100.0	120.0
54"	74.8	74.8	100.0	120.0	

EQUAL LITES WINDOWS					
DESIGN LOAD CAPACITY - PSF					
WINDOW DIMS.		GLASS TYPE '1'		GLASS TYPE '2'	
WIDTH	HEIGHT	EXT.(+)	INT.(-)	EXT.(+)	INT.(-)
24"	96"	100.0	161.9	100.0	210.0
30"		100.0	118.8	100.0	120.0
32"		100.0	111.9	100.0	120.0
36"		100.0	101.5	100.0	120.0
42"		85.4	85.4	100.0	120.0
48"		76.2	76.2	100.0	120.0
54"	68.9	68.9	100.0	120.0	
24"	108"	100.0	142.4	100.0	210.0
30"		100.0	102.2	100.0	120.0
32"		94.9	94.9	100.0	120.0
36"		85.9	85.9	100.0	120.0
42"		75.3	75.3	100.0	120.0
48"		68.6	68.6	100.0	120.0
24"	120"	100.0	120.0	100.0	120.0
30"		90.7	90.7	100.0	120.0
32"		83.6	83.6	100.0	120.0
36"		75.9	75.9	100.0	120.0
42"		66.4	66.4	100.0	120.0

EQUAL LITES WINDOWS					
DESIGN LOAD CAPACITY - PSF					
WINDOW DIMS.		GLASS TYPE '1'		GLASS TYPE '2'	
WIDTH	HEIGHT	EXT.(+)	INT.(-)	EXT.(+)	INT.(-)
19-1/8"	26"	100.0	210.0	100.0	210.0
26-1/2"		100.0	210.0	100.0	210.0
37"		100.0	210.0	100.0	210.0
53-1/8"		100.0	171.1	100.0	210.0
19-1/8"	38-3/8"	100.0	210.0	100.0	210.0
26-1/2"		100.0	210.0	100.0	210.0
37"		100.0	197.2	100.0	210.0
53-1/8"	100.0	124.1	100.0	206.9	
19-1/8"	50-5/8"	100.0	210.0	100.0	210.0
26-1/2"		100.0	210.0	100.0	210.0
37"		100.0	168.3	100.0	210.0
53-1/8"		100.0	101.2	100.0	168.7
19-1/8"	63"	100.0	210.0	100.0	210.0
26-1/2"		100.0	207.5	100.0	210.0
37"		100.0	154.9	100.0	210.0
53-1/8"	88.1	88.1	100.0	120.0	
19-1/8"	72"	100.0	210.0	100.0	210.0
26-1/2"		100.0	181.5	100.0	210.0
37"		100.0	146.8	100.0	210.0
53-1/8"	82.0	82.0	100.0	120.0	
19-1/8"	76"	100.0	210.0	100.0	210.0
26-1/2"		100.0	171.4	100.0	210.0
37"		100.0	136.6	100.0	210.0
53-1/8"		80.0	80.0	100.0	120.0

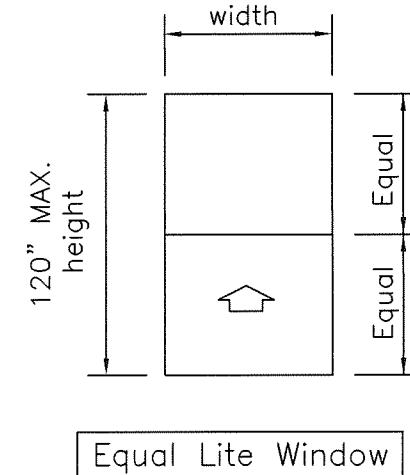

Equal Lite Window

**PRODUCT RENEWED**  
as complying with the Florida  
Building Code  
Acceptance No. 20-0213-05  
Expiration Date 5/5/25  
By Ashley J. Chant  
Miami Dade Product Control

All values shown are Design PSF (Pounds per Square Foot)

VALUES FOR EXTERIOR LOADS(+) SHOWN ARE  
FOR SILL WITH WATERBAR ADAPTER  
FOR WINDOWS WITHOUT WATERBAR ADAPTER  
LIMIT EXTERIOR(+) LOADS TO 80.0 PSF

NOTE:  
GLASS CAPACITIES ON THIS SHEET ARE  
BASED ON ASTM E1300-09 (3 SEC. GUSTS)  
AND FLORIDA BUILDING COMMISSION  
DECLARATORY STATEMENT DCA05-DEC-219

Revision:

PREPARED BY A. LYNN MILLER 1070 TECHNOLOGY DRIVE N. VENICE, FL 34275 (941) 480-1600 REGISTRATION #29296	Date	2/10/2020	Drawn By ALAN KINNE SH360LM-NOA
	Series	SH360	
DESIGN LOAD TABLES		5 OF 14	DWG No. SH360LM-NOA

**WINDOOR**  
INCORPORATED  
7500 AMSTERDAM DRIVE  
ORLANDO, FL 32832  
(407) 481-8400

ANTHONY LYNN MILLER  
LICENSE  
No. 58705  
2/10/20  
STATE OF FLORIDA  
PROFESSIONAL ENGINEER

A. LYNN MILLER, P.E.  
P.E.# 58705

NOTE:  
GLASS CAPACITIES ON THIS SHEET ARE  
BASED ON ASTM E1300-09 (3 SEC. GUSTS)  
AND FLORIDA BUILDING COMMISSION  
DECLARATORY STATEMENT DCA05-DEC-219

**EQUAL LITES WINDOWS**

**DESIGN LOAD CAPACITY - PSF**

WINDOW DIMS.		GLASS TYPE '3'		GLASS TYPE '3A'		GLASS TYPE '4'		GLASS TYPE '4A'	
WIDTH	HEIGHT	EXT.(+)	INT.(-)	EXT.(+)	INT.(-)	EXT.(+)	INT.(-)	EXT.(+)	INT.(-)
48"	24"	100.0	210.0	100.0	210.0	100.0	210.0	100.0	209.0
	30"	100.0	210.0	100.0	210.0	100.0	210.0	100.0	209.0
	32"	100.0	210.0	100.0	210.0	100.0	210.0	100.0	209.0
	36"	100.0	210.0	100.0	210.0	100.0	210.0	100.0	203.0
	42"	100.0	210.0	100.0	210.0	100.0	210.0	100.0	171.0
	48"	100.0	200.0	100.0	200.0	100.0	200.0	100.0	148.0
60"	24"	100.0	171.4	100.0	171.4	100.0	171.4	100.0	131.0
	30"	100.0	210.0	100.0	210.0	100.0	210.0	100.0	209.0
	32"	100.0	210.0	100.0	210.0	100.0	210.0	100.0	200.0
	36"	100.0	210.0	100.0	210.0	100.0	210.0	100.0	188.0
	42"	100.0	210.0	100.0	210.0	100.0	210.0	100.0	156.0
	48"	100.0	210.0	100.0	210.0	100.0	210.0	100.0	135.0
72"	24"	100.0	120.0	100.0	120.0	100.0	120.0	100.0	117.0
	30"	100.0	120.0	100.0	120.0	100.0	120.0	100.0	101.0
	32"	100.0	210.0	100.0	210.0	100.0	210.0	100.0	205.0
	36"	100.0	210.0	100.0	210.0	100.0	210.0	100.0	155.0
	42"	100.0	210.0	100.0	191.2	100.0	210.0	100.0	147.0
	48"	100.0	210.0	100.0	198.4	100.0	210.0	100.0	137.0
84"	24"	100.0	120.0	100.0	120.0	100.0	120.0	100.0	119.0
	30"	100.0	120.0	100.0	120.0	100.0	120.0	100.0	102.0
	32"	100.0	210.0	100.0	210.0	100.0	210.0	100.0	180.0
	36"	100.0	210.0	100.0	210.0	100.0	210.0	100.0	136.0
	42"	100.0	210.0	100.0	210.0	100.0	210.0	100.0	129.0
	48"	100.0	120.0	100.0	120.0	100.0	120.0	100.0	117.0
96"	24"	100.0	120.0	100.0	120.0	100.0	120.0	100.0	105.0
	30"	100.0	120.0	100.0	120.0	100.0	120.0	100.0	105.0
	32"	100.0	120.0	100.0	120.0	100.0	120.0	100.0	109.0
	36"	100.0	120.0	100.0	120.0	100.0	120.0	100.0	102.0
	42"	100.0	120.0	100.0	120.0	100.0	120.0	100.0	90.8
	48"	100.0	120.0	100.0	120.0	100.0	120.0	100.0	90.6
108"	24"	100.0	120.0	100.0	120.0	100.0	120.0	100.0	80.9
	30"	100.0	120.0	100.0	120.0	100.0	120.0	100.0	83.7
	32"	100.0	120.0	100.0	120.0	100.0	120.0	100.0	80.9
	36"	100.0	120.0	100.0	120.0	100.0	120.0	100.0	83.7
	42"	100.0	120.0	100.0	112.6	100.0	120.0	100.0	73.2
	48"	100.0	120.0	100.0	112.6	100.0	120.0	100.0	74.5
120"	24"	100.0	120.0	100.0	120.0	100.0	120.0	100.0	140.0
	30"	100.0	120.0	100.0	120.0	100.0	120.0	100.0	103.0
	32"	100.0	120.0	100.0	120.0	100.0	120.0	100.0	103.0
	36"	100.0	120.0	100.0	120.0	100.0	120.0	100.0	97.6
	42"	100.0	120.0	100.0	120.0	100.0	120.0	100.0	97.6
	48"	100.0	120.0	100.0	120.0	100.0	120.0	100.0	88.9

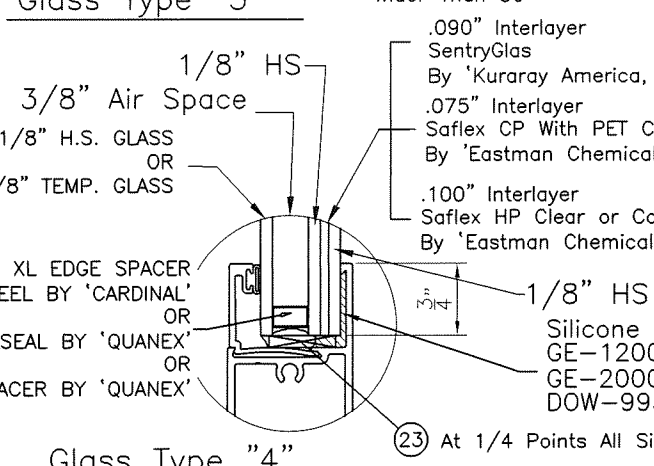
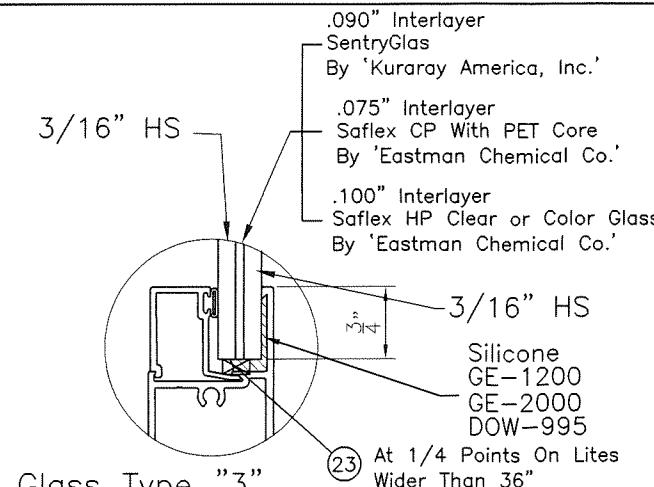

**EQUAL LITES WINDOWS**  
**DESIGN LOAD CAPACITY - PSF**

WINDOW DIMS.		GLASS TYPE '3'		GLASS TYPE '3A'		GLASS TYPE '4'		GLASS TYPE '4A'	
WIDTH	HEIGHT	EXT.(+)	INT.(-)	EXT.(+)	INT.(-)	EXT.(+)	INT.(-)	EXT.(+)	INT.(-)
19-1/8"	26"	100.0	210.0	100.0	210.0	100.0	210.0	100.0	210.0
26-1/2"		100.0	210.0	100.0	210.0	100.0	210.0	100.0	210.0
37"		100.0	210.0	100.0	210.0	100.0	210.0	100.0	210.0
53-1/8"	38-3/8"	100.0	210.0	100.0	210.0	100.0	210.0	100.0	210.0
19-1/8"		100.0	210.0	100.0	210.0	100.0	210.0	100.0	210.0
26-1/2"		100.0	210.0	100.0	210.0	100.0	210.0	100.0	210.0
37"	50-5/8"	100.0	210.0	100.0	210.0	100.0	210.0	100.0	210.0
53-1/8"		100.0	206.9	100.0	206.9	100.0	206.9	100.0	180.0
19-1/8"		100.0	210.0	100.0	210.0	100.0	210.0	100.0	210.0
26-1/2"	63"	100.0	210.0	100.0	210.0	100.0	210.0	100.0	210.0
37"		100.0	210.0	100.0	191.9	100.0	210.0	100.0	145.0
53-1/8"		100.0	120.0	100.0	120.0	100.0	120.0	100.0	99.0
19-1/8"	72"	100.0	210.0	100.0	210.0	100.0	210.0	100.0	210.0
26-1/2"		100.0	210.0	100.0	210.0	100.0	210.0	100.0	184.0
37"		100.0	210.0	100.0	196.5	100.0	210.0	100.0	134.0
53-1/8"	76"	100.0	120.0	100.0	120.0	100.0	120.0	94.6	90.0
19-1/8"		100.0	210.0	100.0	210.0	100.0	210.0	100.0	210.0
26-1/2"		100.0	210.0	100.0	210.0	100.0	210.0	100.0	169.0
37"	76"	100.0	210.0	100.0	194.8	100.0	210.0	100.0	124.0
53-1/8"		100.0	120.0	100.0	120.0	100.0	120.0	88.3	85.0

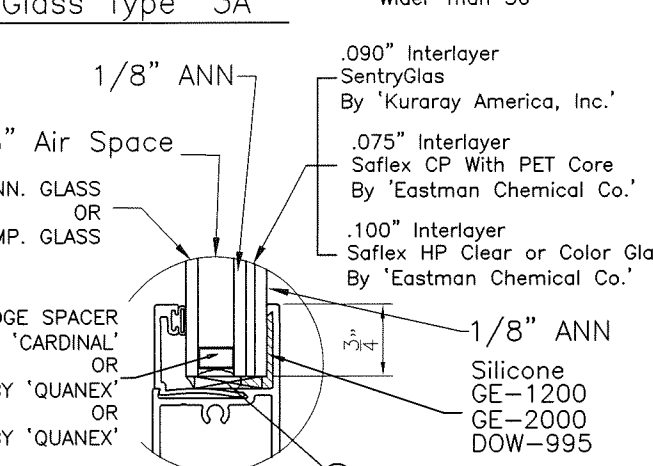
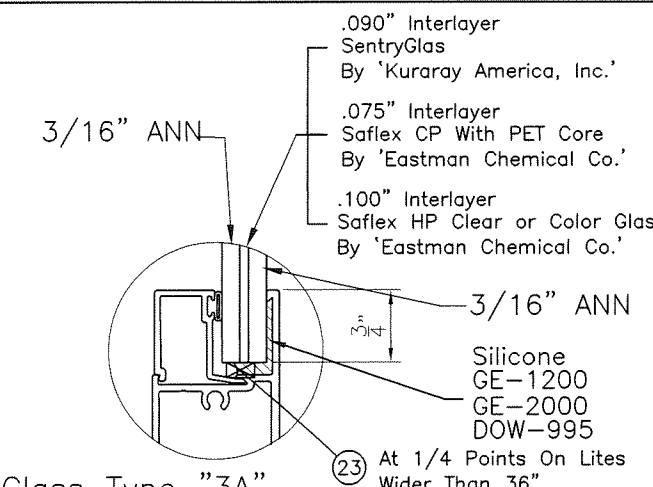

NOTE:  
TO QUALIFY FOR SMALL MISSILE IMPACT RATING  
THE EXTERIOR PANE FOR GLASS TYPES "4"  
AND "4A" MUST BE TEMPERED.  
(INSTALLATIONS ABOVE 30 FT. OF GRADE)

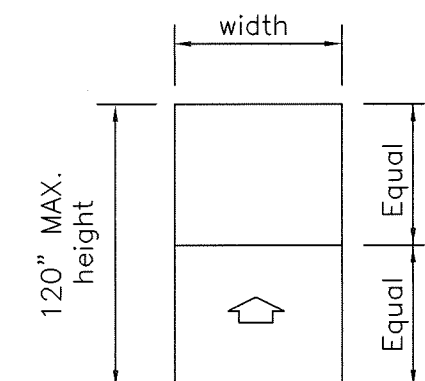

Equal Lite Window

All values shown are Design PSF (Pounds per Square Foot)  
VALUES FOR EXTERIOR LOADS(+) SHOWN ARE  
FOR SILL WITH WATERBAR ADAPTER  
FOR WINDOWS WITHOUT WATERBAR ADAPTER  
LIMIT EXTERIOR(+) LOADS TO 80.0 PSF

**PRODUCT RENEWED**  
as complying with the Florida  
Building Code  
Acceptance No. 20-0213-05  
Expiration Date 5/5/25  
By [Signature]  
Miami Dade Product Control

Revisions:

PREPARED BY A. LYNN MILLER  
1070 TECHNOLOGY DRIVE  
N. VENICE, FL 34275  
(941) 480-1600  
REGISTRATION #29296

DATE: 2/10/2020  
DRAWN BY: ALAN KINNE  
SERIES: SH360LM-NOA

WINDOOR®  
INCORPORATED  
7500 AMSTERDAM DRIVE  
ORLANDO, FL 32832  
(407) 481-8400

SERIES "360" ALUM SINGLE HUNG WDW (LM/SMI)  
DESIGN LOAD TABLES/GLASS  
SH360

6 OF 14

ANTHONY LYNN MILLER  
LICENSE  
No. 58705  
2/10/20  
STATE OF FLORIDA  
PROFESSIONAL ENGINEER

A. LYNN MILLER, P.E.  
P.E.# 58705

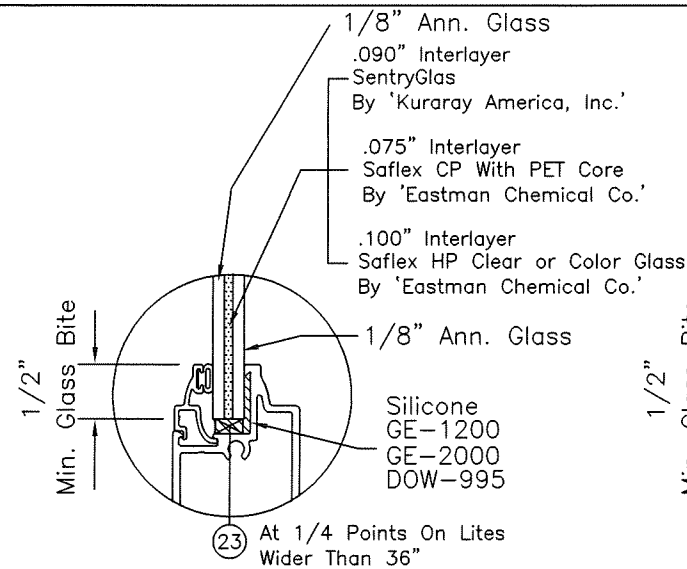

**Glass Type "1"**  
5/16" Nominal Glass  
Annealed/Annealed

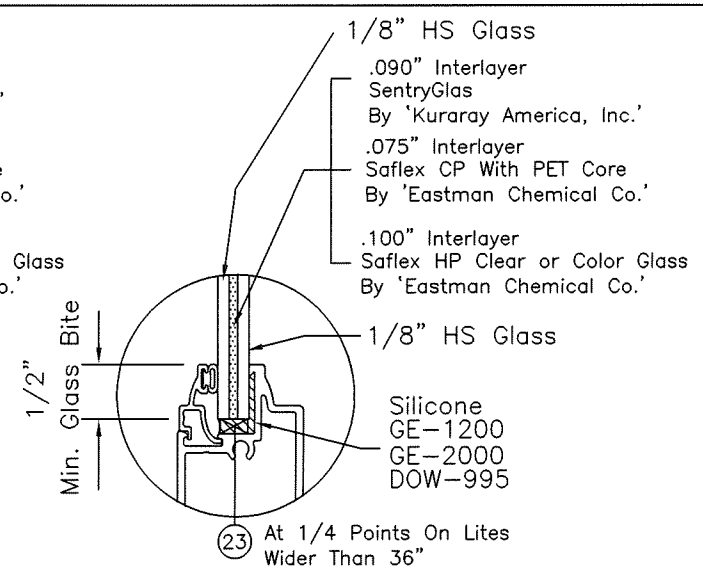

**Glass Type "2"**  
5/16" Nominal Glass  
HS/HS

Supplemental Test Results for:  
Air Infiltration – Water Leakage Resistance – Forced Entry

Test Type and Method	Results
Air Infiltration Test (ASTM-E283) @ 1.57 psf pressure differential @ 6.24 psf pressure differential	PASSED ( .044 C.F. / Min / Sq Ft ) PASSED ( .076 C.F. / Min / Sq Ft )
Water Leakage Test (ASTM-E331) without waterbar adaptor with waterbar adaptor	No leakage allowed PASSED @ 12.0 PSF PASSED @ 15.0 PSF
Forced Entry Resistance test (ASTM F588 & Grade 10)	PASSED

UNEQUAL LITES WINDOWS (ORIEL)								
DESIGN LOAD CAPACITY – PSF								
WINDOW DIMS.		TOP VENT HEIGHT	GLASS TYPE '1'		GLASS TYPE '2'			
WIDTH	HEIGHT		EXT.(+)	INT.(–)	EXT.(+)	INT.(–)		
24"	96" (MAX.)	48"	100.0	161.9	100.0	210.0		
30"			100.0	118.8	100.0	120.0		
32"			100.0	111.9	100.0	120.0		
36"			100.0	101.5	100.0	120.0		
42"			85.4	85.4	100.0	120.0		
48"			76.2	76.2	100.0	120.0		
54"	68.9	68.9	100.0	120.0				
24"	108" (MAX.)	54"	100.0	142.4	100.0	210.0		
30"			100.0	102.2	100.0	120.0		
32"			94.9	94.9	100.0	120.0		
36"			85.9	85.9	100.0	120.0		
42"			75.3	75.3	100.0	120.0		
48"			68.6	68.6	100.0	120.0		
24"	120" (MAX.)	60"	100.0	120.0	100.0	120.0		
30"			90.7	90.7	100.0	120.0		
32"			83.6	83.6	100.0	120.0		
36"			75.9	75.9	100.0	120.0		
42"			66.4	66.4	100.0	120.0		
24"			120" (MAX.)	66"	100.0	120.0	100.0	120.0
30"	81.7	81.7			100.0	120.0		
32"	77.7	77.7			100.0	120.0		
36"	67.4	67.4			100.0	120.0		
24"	120" (MAX.)	72"			100.0	113.6	100.0	120.0
30"					77.1	77.1	100.0	120.0
32"			70.1	70.1	100.0	120.0		
36"			60.3	60.3	100.0	120.0		
24"			120" (MAX.)	78"	100.0	120.0	100.0	120.0
30"					71.2	71.2	100.0	120.0
32"	63.8	63.8			100.0	120.0		
24"	120" (MAX.)	84"			100.0	120.0	100.0	120.0
30"					66.6	66.6	100.0	120.0

All values shown are Design PSF (Pounds per Square Foot)

UNEQUAL LITES WINDOWS (ORIEL)								
DESIGN LOAD CAPACITY – PSF								
WINDOW DIMS.		TOP VENT HEIGHT	GLASS TYPE '1'		GLASS TYPE '2'			
WIDTH	HEIGHT		EXT.(+)	INT.(–)	EXT.(+)	INT.(–)		
19-1/8"	96" (MAX.)	48"	100.0	210.0	100.0	210.0		
26-1/2"			100.0	138.5	100.0	210.0		
37"			99.3	99.3	100.0	120.0		
53-1/8"			69.8	69.8	100.0	120.0		
19-1/8"	108" (MAX.)	54"	100.0	210.0	100.0	210.0		
26-1/2"			100.0	120.0	100.0	120.0		
37"			83.6	83.6	100.0	120.0		
19-1/8"			120" (MAX.)	60"	100.0	210.0	100.0	210.0
26-1/2"	100.0	108.6			100.0	120.0		
37"	73.7	73.7			100.0	120.0		
19-1/8"	120" (MAX.)	66"			100.0	210.0	100.0	210.0
26-1/2"			99.5	99.5	100.0	120.0		
37"			65.7	65.7	100.0	120.0		
19-1/8"			120" (MAX.)	72"	100.0	210.0	100.0	210.0
26-1/2"	93.9	93.9			100.0	120.0		
19-1/8"	120" (MAX.)	78"			100.0	120.0	100.0	120.0
26-1/2"					88.0	88.0	100.0	120.0
19-1/8"			120" (MAX.)	84"	100.0	120.0	100.0	120.0
26-1/2"					79.8	79.8	100.0	120.0

NOTE:  
GLASS CAPACITIES ON THIS SHEET ARE  
BASED ON ASTM E1300-09 (3 SEC. GUSTS)  
AND FLORIDA BUILDING COMMISSION  
DECLARATORY STATEMENT DCA05-DEC-219

VALUES FOR EXTERIOR LOADS(+) SHOWN ARE  
FOR SILL WITH WATERBAR ADAPTER  
FOR WINDOWS WITHOUT WATERBAR ADAPTER  
LIMIT EXTERIOR(+) LOADS TO 80.0 PSF

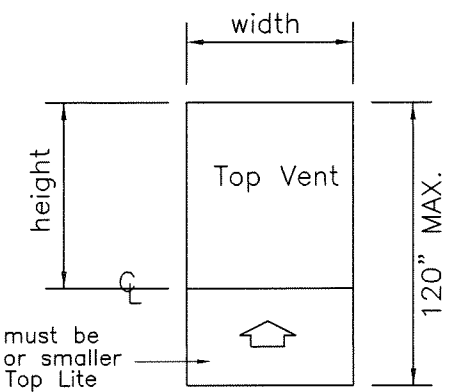

Unequal Lite Window

Revision:

PREPARED BY A. LYNN MILLER 1070 TECHNOLOGY DRIVE N. VENICE, FL 34275 (941) 480-1600	REGISTRATION #29296	Date	2/10/2020
		By	ALAN KINNE
<b>WINDOOR</b> INCORPORATED 7500 AMSTERDAM DRIVE ORLANDO, FL 32832 (407) 481-8400	SERIES "360" ALUM SINGLE HUNG WDW (LM/SMI)	DWG No.	SH360LM-NOA
		Sheet	7 OF 14
DESIGN LOAD TABLES/GLASS		Series	SH360

PROFESSIONAL ENGINEER  
ANTHONY LYNN MILLER  
LICENSE No. 58705  
STATE OF FLORIDA  
2/10/20  
By *Anthony Lynn Miller*  
Miami Dad's Product Control

A. LYNN MILLER, P.E.  
P.E.# 58705

NOTE:  
GLASS CAPACITIES ON THIS SHEET ARE  
BASED ON ASTM E1300-09 (3 SEC. GUSTS)  
AND FLORIDA BUILDING COMMISSION  
DECLARATORY STATEMENT DCA05-DEC-219

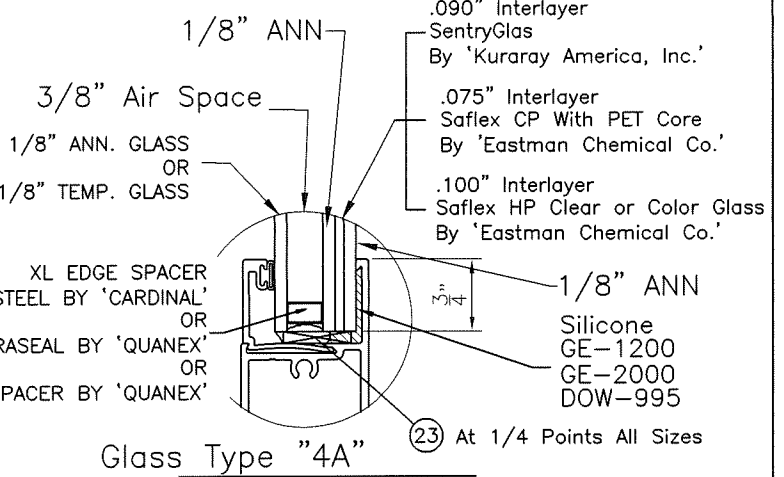
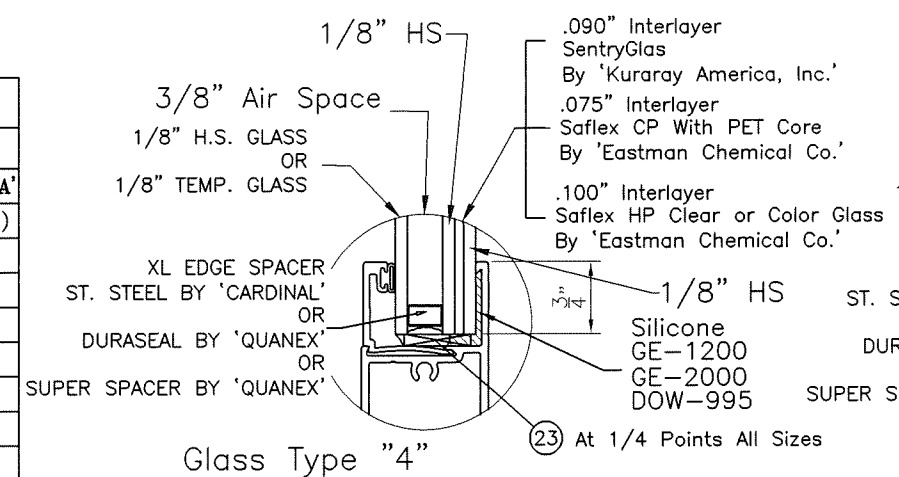
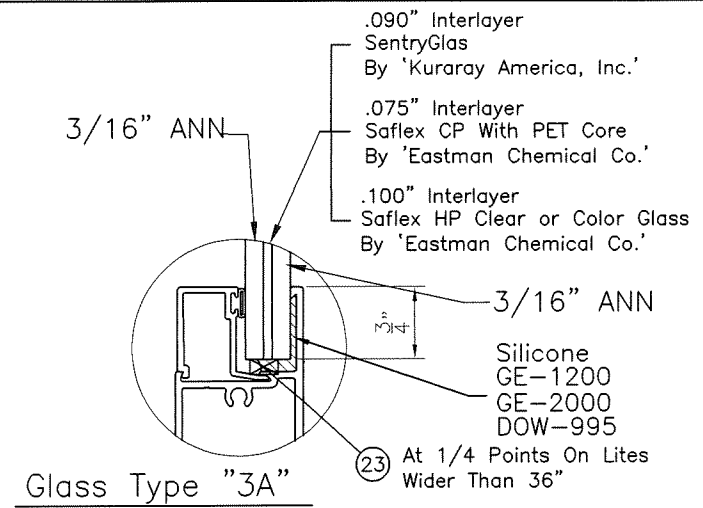
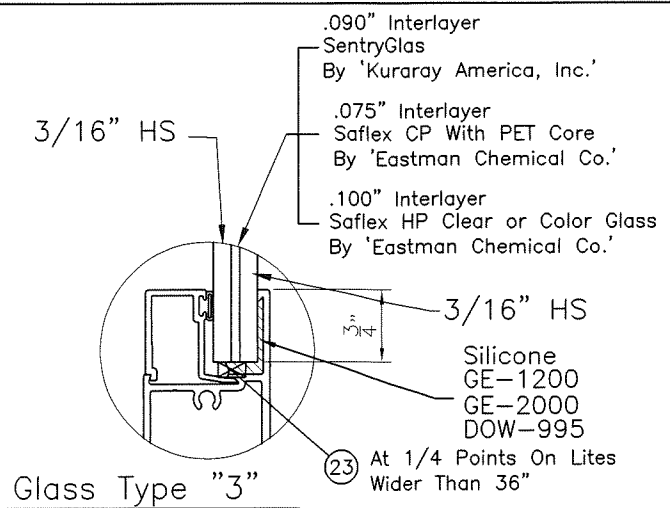

UNEQUAL LITES WINDOWS (ORIEL)												
DESIGN LOAD CAPACITY - PSF												
WINDOW DIMS.		TOP VENT HEIGHT	GLASS TYPE '3'		GLASS TYPE '3A'		GLASS TYPE '4'		GLASS TYPE '4A'			
WIDTH	HEIGHT		EXT.(+)	INT.(-)	EXT.(+)	INT.(-)	EXT.(+)	INT.(-)	EXT.(+)	INT.(-)		
24"	96" (MAX.)	48"	100.0	210.0	100.0	210.0	100.0	210.0	100.0	154.0		
30"			100.0	120.0	100.0	120.0	100.0	120.0	100.0	114.0		
32"			100.0	120.0	100.0	120.0	100.0	120.0	100.0	114.0		
36"			100.0	120.0	100.0	120.0	100.0	120.0	99.9	99.9		
42"			100.0	120.0	100.0	120.0	100.0	120.0	88.8	88.8		
48"			100.0	120.0	100.0	120.0	100.0	120.0	82.3	82.3		
54"			100.0	120.0	100.0	112.6	100.0	120.0	73.7	73.7		
24"	108" (MAX.)	54"	100.0	210.0	100.0	210.0	100.0	210.0	100.0	138.0		
30"			100.0	120.0	100.0	120.0	100.0	120.0	100.0	101.0		
32"			100.0	120.0	100.0	120.0	100.0	120.0	100.0	101.0		
36"			100.0	120.0	100.0	120.0	100.0	120.0	87.4	87.4		
42"			100.0	120.0	100.0	120.0	100.0	120.0	78.2	78.2		
48"			100.0	120.0	100.0	112.2	100.0	120.0	71.5	71.5		
24"	120" (MAX.)	60"	100.0	120.0	100.0	120.0	100.0	120.0	100.0	127.0		
30"			100.0	120.0	100.0	120.0	100.0	120.0	93.4	93.4		
32"			100.0	120.0	100.0	120.0	100.0	120.0	93.4	93.4		
36"			100.0	120.0	100.0	120.0	100.0	120.0	79.0	79.0		
42"			100.0	120.0	100.0	114.1	100.0	120.0	69.1	69.1		
24"			120" (MAX.)	66"	100.0	120.0	100.0	120.0	100.0	120.0	100.0	120.0
30"	100.0	120.0			100.0	120.0	100.0	120.0	83.7	83.7		
32"	100.0	120.0			100.0	120.0	100.0	120.0	83.7	83.7		
36"	100.0	120.0			100.0	120.0	100.0	120.0	70.0	70.0		
24"	120" (MAX.)	72"			100.0	120.0	100.0	120.0	100.0	120.0	100.0	117.0
30"					100.0	120.0	100.0	120.0	100.0	120.0	76.2	76.2
32"			100.0	120.0	100.0	120.0	100.0	120.0	76.2	76.2		
36"			100.0	120.0	100.0	120.0	100.0	115.2	61.9	61.9		
24"			120" (MAX.)	78"	100.0	120.0	100.0	120.0	100.0	120.0	100.0	120.0
30"					100.0	120.0	100.0	120.0	100.0	120.0	72.2	72.2
32"	100.0	120.0			100.0	120.0	100.0	120.0	72.2	72.2		
24"	120" (MAX.)	84"			100.0	120.0	100.0	120.0	100.0	120.0	100.0	118.0
30"					100.0	120.0	100.0	120.0	100.0	120.0	68.9	68.9

All values shown are Design PSF (Pounds per Square Foot)

UNEQUAL LITES WINDOWS (ORIEL)												
DESIGN LOAD CAPACITY - PSF												
WINDOW DIMS.		TOP VENT HEIGHT	GLASS TYPE '3'		GLASS TYPE '3A'		GLASS TYPE '4'		GLASS TYPE '4A'			
WIDTH	HEIGHT		EXT.(+)	INT.(-)	EXT.(+)	INT.(-)	EXT.(+)	INT.(-)	EXT.(+)	INT.(-)		
19-1/8"	96" (MAX.)	48"	100.0	210.0	100.0	210.0	100.0	210.0	100.0	209.0		
26-1/2"			100.0	120.0	100.0	120.0	100.0	120.0	100.0	136.0		
37"			100.0	120.0	100.0	120.0	100.0	120.0	97.8	97.8		
53-1/8"			100.0	120.0	100.0	114.4	100.0	120.0	75.4	75.4		
19-1/8"	108" (MAX.)	54"	100.0	210.0	100.0	210.0	100.0	210.0	100.0	204.0		
26-1/2"			100.0	120.0	100.0	120.0	100.0	120.0	100.0	120.0		
37"			100.0	120.0	100.0	120.0	100.0	120.0	85.4	85.4		
19-1/8"			120" (MAX.)	60"	100.0	210.0	100.0	204.2	100.0	210.0	100.0	205.0
26-1/2"	100.0	120.0			100.0	120.0	100.0	120.0	100.0	107.0		
37"	100.0	120.0			100.0	120.0	100.0	120.0	77.1	77.1		
19-1/8"	120" (MAX.)	66"			100.0	210.0	100.0	210.0	100.0	210.0	100.0	207.0
26-1/2"			100.0	120.0	100.0	120.0	100.0	120.0	99.7	99.7		
37"			100.0	120.0	100.0	120.0	100.0	120.0	68.4	68.4		
19-1/8"			120" (MAX.)	72"	100.0	210.0	100.0	210.0	100.0	210.0	100.0	199.0
26-1/2"	100.0	120.0			100.0	120.0	100.0	120.0	94.5	94.5		
19-1/8"	120" (MAX.)	78"			100.0	210.0	100.0	210.0	100.0	210.0	100.0	192.0
26-1/2"					100.0	120.0	100.0	120.0	100.0	120.0	91.3	91.3
19-1/8"			120" (MAX.)	84"	100.0	210.0	100.0	210.0	100.0	210.0	100.0	181.0
26-1/2"					100.0	120.0	100.0	120.0	100.0	120.0	89.2	89.2

VALUES FOR EXTERIOR LOADS(+) SHOWN ARE  
FOR SILL WITH WATERBAR ADAPTER  
FOR WINDOWS WITHOUT WATERBAR ADAPTER  
LIMIT EXTERIOR(+) LOADS TO 80.0 PSF

NOTE:  
TO QUALIFY FOR SMALL MISSILE IMPACT RATING  
THE EXTERIOR PANE FOR GLASS TYPES "4"  
AND "4A" MUST BE TEMPERED.  
(INSTALLATIONS ABOVE 30 FT. OF GRADE)

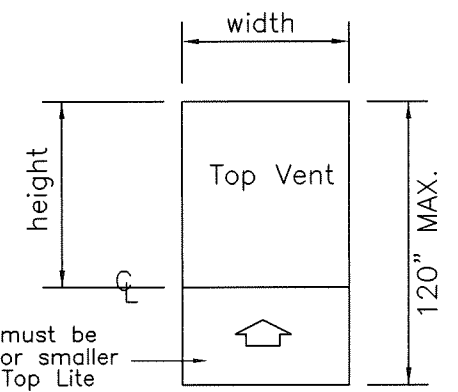

Unequal Lite Window

PRODUCT RENEWED  
as complying with the Florida  
Building Code  
Acceptance No. 20-0213-05  
Expiration Date 5/5/25  
By *Anthony L. Miller*  
Miami Dade Product Control

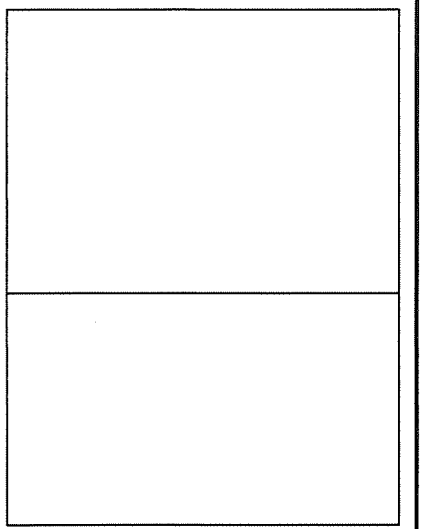

Revisions:

PREPARED BY A. LYNN MILLER  
1070 TECHNOLOGY DRIVE  
N. VENICE, FL 34275  
(941) 480-1600  
REGISTRATION #29296

WINDOOR®  
INCORPORATED  
7500 AMSTERDAM DRIVE  
ORLANDO, FL 32832  
(407) 481-8400

SERIES "360" ALUM SINGLE HUNG WDW (LM/SMI) 2/10/2020  
DESIGN LOAD TABLES/GLASS  
ALAN KINNE  
SH360LM-NOA  
8 OF 14  
SH360

ANTHONY LYNN MILLER  
LICENSE  
No. 58705  
2/10/20  
STATE OF FLORIDA  
PROFESSIONAL ENGINEER  
A. LYNN MILLER, P.E.  
P.E.# 58705

**Installation Type "A"**

w/ 1 x 4 Beveled P.T. Wood Buck

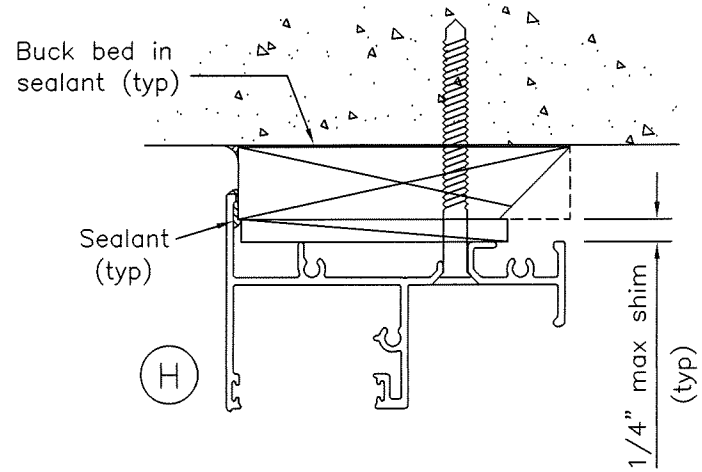

1/4" Dia. Flat Head Ultracon Or Kwik-con (or equal)

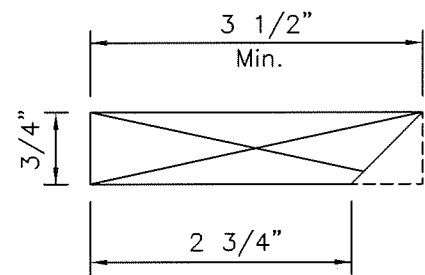
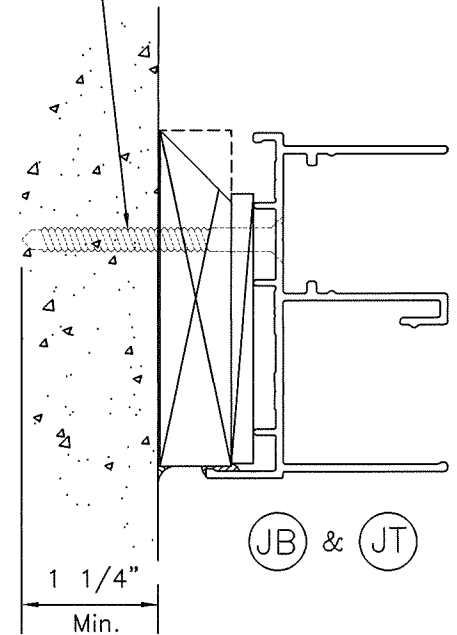

1 x 4 Beveled P.T. Wood Buck (typ.)

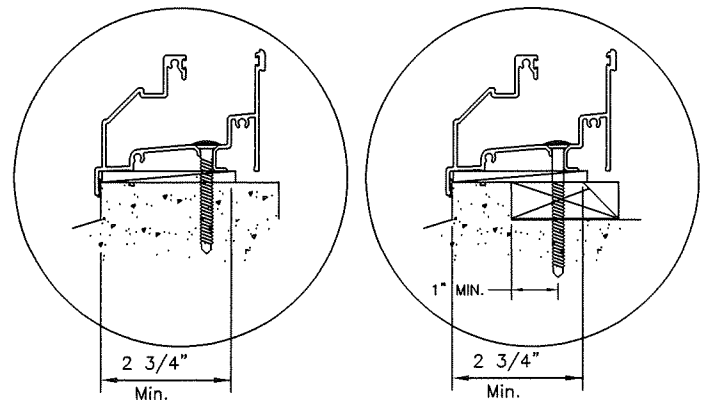

Optional Pre-Cast Sill

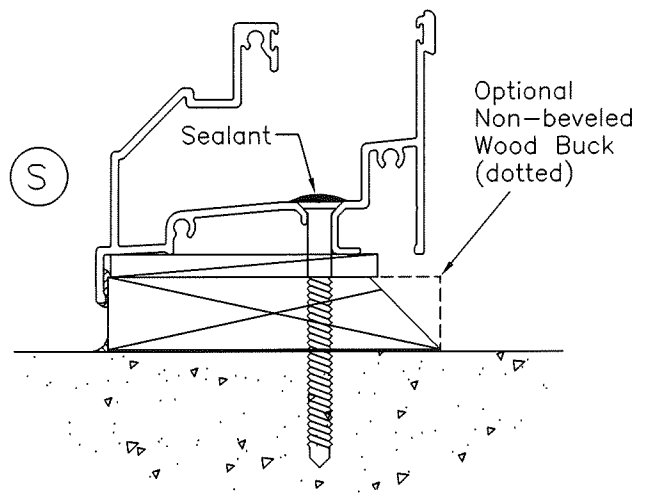

**IMPORTANT NOTE:**  
Wood Bucks must sustain loads imposed by glazing system and transfer them to the building structure.

**TYPICAL ANCHORS:** SEE ELEV. FOR SPACING  
 1/4" DIA. ULTRACON BY 'ELCO' (Fu=177 KSI, Fy=155 KSI)  
 1/4" DIA. HILTI KWIK-CON II (Fu=163 KSI, Fy=157 KSI)  
 INTO 2BY WOOD BUCKS OR WOOD STRUCTURES  
 1-1/2" MIN. PENETRATION INTO WOOD  
 THRU 1BY BUCKS INTO CONC. OR BUCKS  
 1-1/4" MIN. EMBED INTO CONCRETE (HEAD/SILL/JAMBS)  
 1-1/4" MIN. EMBED INTO BLOCKS (JAMBS)  
 DIRECTLY INTO CONCRETE OR BLOCKS  
 1-3/4" MIN. EMBED INTO CONCRETE (HEAD/SILL/JAMBS)  
 1-3/4" MIN. EMBED INTO FILLED BLOCKS (JAMBS)  
 1/4" DIA. TEKS OR SELF DRILLING SCREWS (GRADE 5 CRS)  
 INTO METAL STRUCTURES (HEAD/SILL/JAMBS)  
 (3) THREADS MIN. TO EXTEND BEYOND METAL THICKNESS  
 ALUMINUM : 1/8" THK. MIN. (6063-T5 MIN.)  
 STEEL : 1/8" THK. MIN. (Fy = 36 KSI MIN.)  
 (STEEL IN CONTACT WITH ALUMINUM TO BE PLATED OR PAINTED)  
 #14 SMS (GRADE 2 CRS)  
 INTO MIAMI-DADE COUNTY APPROVED MULLIONS  
 (3) THREADS MIN. TO EXTEND BEYOND METAL THICKNESS  
 ALUMINUM: 1/8" THK. MIN. (6063-T5 MIN.) (NO SHIMS)  
 STEEL: 1/8" THK. MIN. (Fy = 36 KSI MIN.)  
 (STEEL IN CONTACT WITH ALUMINUM TO BE PLATED OR PAINTED)  
**TYPICAL EDGE DISTANCE**  
 INTO CONCRETE AND MASONRY = 2-1/2" MIN.  
 INTO WOOD STRUCTURE = 1" MIN.  
 INTO METAL STRUCTURE = 3/4" MIN.  
 WOOD AT HEAD, SILL OR JAMBS SG = 0.55 MIN.  
 CONCRETE AT HEAD, SILL OR JAMBS f'c = 3000 PSI MIN.  
 C-90 FILLED BLOCK AT JAMBS f'm = 2000 PSI MIN.

Values for Installation Type "A" apply to the following installation types, with maximum shim space 1/4":  
 1- Using 1by P.T. wood bucks, min. 3/4" thick,  
 2- Directly into masonry, without the use of wood bucks.  
 3- Directly into a steel or aluminum structure  
 Min. 1/8" thick and using #14 Tekes or Self drilling screws.  
 Structure must be designed by others to sustain the loads imposed by the window.

PRODUCT RENEWED  
 as complying with the Florida  
 Building Code  
 Acceptance No 26-0213-05  
 Expiration Date 5/5/25  
 By [Signature]  
 Miami Dade Product Control

Revision:	

PREPARED BY A. LYNN MILLER 1070 TECHNOLOGY DRIVE N. VENICE, FL 34275 (941) 480-1600 REGISTRATION #29296	Date	2/10/2020	Rev	
	Drawn By	ALAN KINNE	DWG No.	SH360LM-NOA
<b>WINDOOR</b> INCORPORATED 7500 AMSTERDAM DRIVE ORLANDO, FL 32832 (407) 481-8400	SERIES "360" ALUM SINGLE HUNG WDW (LM/SMI)	ANCHORS	Sheet	9 OF 14
			Series	SH360

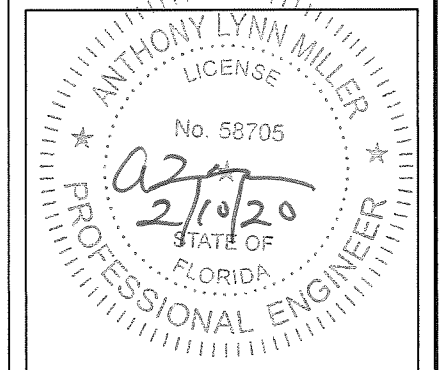

A. LYNN MILLER, P.E.  
 P.E.# 58705



### Installation Type "B"

w/ 2 x 4 Beveled P.T. Wood Buck

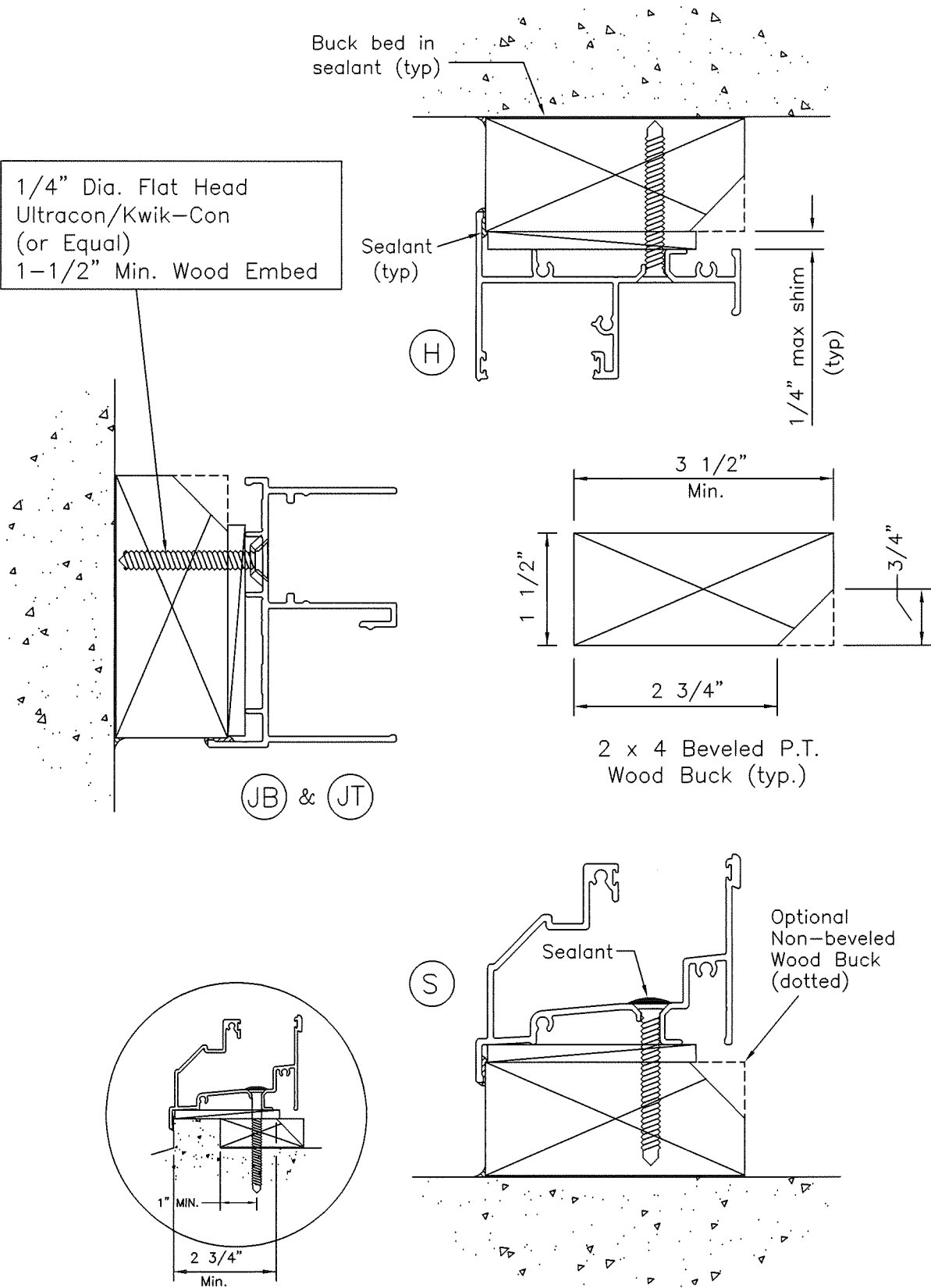

Optional Pre-Cast Sill

### Installation Type "C"

based on wood penetration only using 1 x 4 or 2 x 4 wood bucks

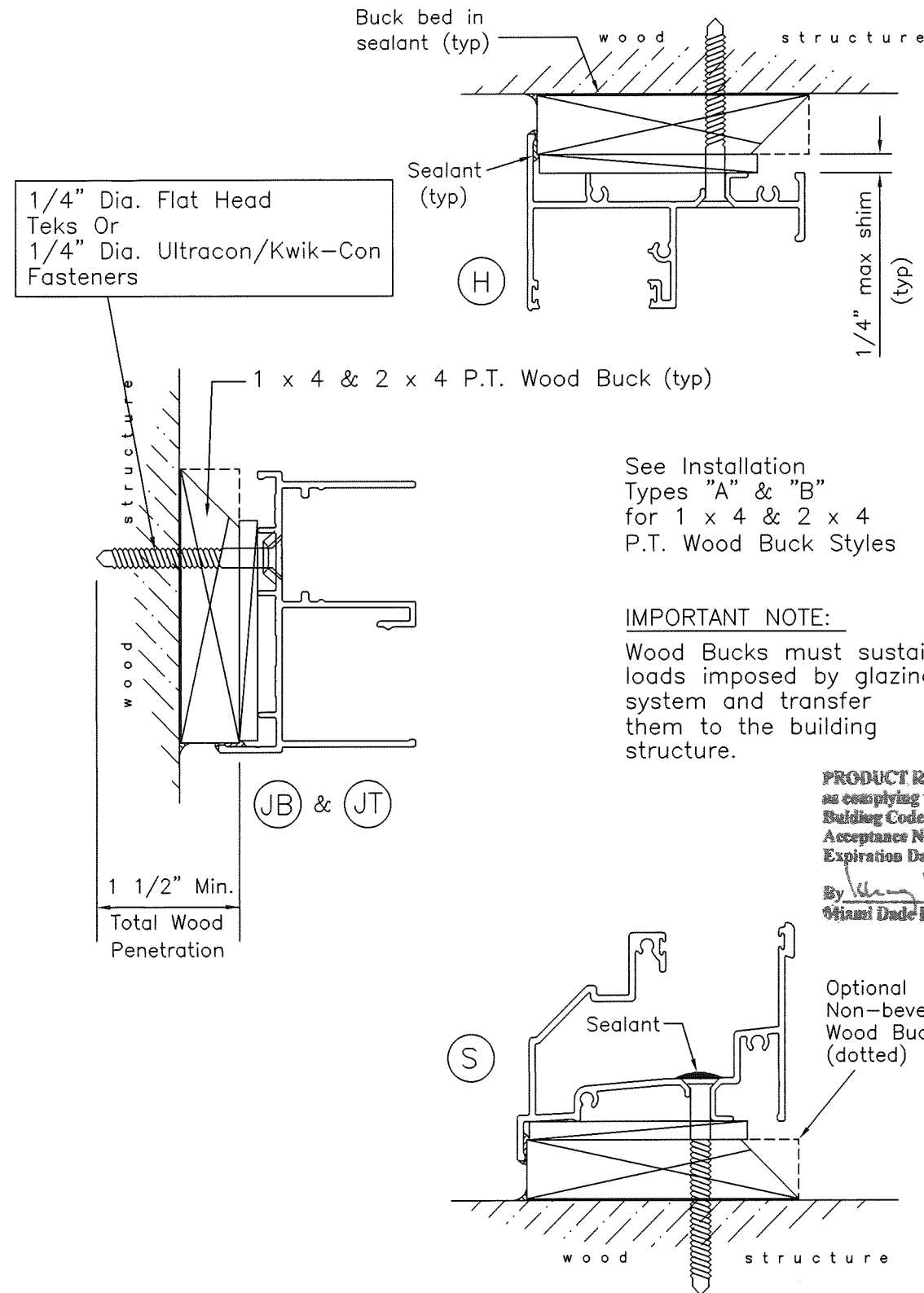

See Installation Types "A" & "B" for 1 x 4 & 2 x 4 P.T. Wood Buck Styles

#### IMPORTANT NOTE:

Wood Bucks must sustain loads imposed by glazing system and transfer them to the building structure.

**PRODUCT RENEWED**  
 as complying with the Florida Building Code  
 Acceptance No 26-0213-05  
 Expiration Date 5/5/25  
 By *Anthony L. Miller*  
 Miami Dade Product Control

Revision:
-----------

Prepared By	A. LYNN MILLER
Date	2/10/2020
Drawn By	ALAN KINNE
Sheet No.	10 OF 14
Series	SH360
Desc.	ANCHORS
Title	SERIES "360" ALUM SINGLE HUNG WDW (LM/SMI)
Registration #	REGISTRATION #29296
Address	1070 TECHNOLOGY DRIVE N. VENICE, FL 34275 (941) 480-1600
Company	WINDOOR® INCORPORATED
Address	7500 AMSTERDAM DRIVE ORLANDO, FL 32832 (407) 481-8400
Rev.	SH360LM-NOA

Professional Engineer Seal for Anthony Lynn Miller, License No. 58705, State of Florida. The seal includes a signature and the date 2/10/20.

A. LYNN MILLER, P.E.  
 P.E.# 58705

ANCHORS						
DESIGN LOAD CAPACITY - PSF						
WINDOW DIMS.		NO. OF ANCHORS AT JAMB	STD. HOLE PATTERN W/O ADDL. ANCHOR	STD. HOLE PATTERN WITH ADDL. ANCHOR		
WIDTH	HEIGHT		EXT.(+) & INT.(-)	EXT.(+) & INT.(-)		
24"	48"	4	210.0	210.0		
30"			210.0	210.0		
32"			210.0	210.0		
36"			196.0	210.0		
42"			174.2	210.0		
48"			151.7	196.0		
54"	127.1	178.2				
24"	60"	6	210.0	210.0		
30"			210.0	210.0		
32"			210.0	210.0		
36"			210.0	210.0		
42"			171.1	210.0		
48"			134.4	201.6		
54"	110.7	166.0				
24"	72"	8	210.0	210.0		
30"			210.0	210.0		
32"			210.0	210.0		
36"			210.0	210.0		
42"			165.1	210.0		
48"			125.4	188.2		
54"	101.2	151.7				
24"	84"	8	210.0	210.0		
30"			210.0	210.0		
32"			207.5	210.0		
36"			190.1	210.0		
42"			164.9	192.0		
48"			122.2	175.3		
54"	96.0	144.0				
24"	96"	8	210.0	210.0		
30"			185.8	209.1		
32"			176.4	198.5		
36"			160.8	180.9		
42"			143.4	161.3		
48"			122.1	147.0		
54"	94.1	135.7				
24"	108"	10	210.0	210.0		
30"			202.3	210.0		
32"			191.7	210.0		
36"			174.2	191.6		
42"			154.5	169.9		
48"			122.1	154.0		
24"	120"	10	210.0	210.0		
30"			179.2	197.1		
32"			169.6	186.6		
36"			153.7	169.1		
42"			135.8	149.3		

ANCHORS				
DESIGN LOAD CAPACITY - PSF				
WINDOW DIMS.		NO. OF ANCHORS AT JAMB	STD. HOLE PATTERN W/O ADDL. ANCHOR	STD. HOLE PATTERN WITH ADDL. ANCHOR
WIDTH	HEIGHT		EXT.(+) & INT.(-)	EXT.(+) & INT.(-)
19-1/8"	26"	4	210.0	210.0
26-1/2"			210.0	210.0
37"			210.0	210.0
53-1/8"			208.6	210.0
19-1/8"	38-3/8"	4	210.0	210.0
26-1/2"			210.0	210.0
37"			210.0	210.0
53-1/8"			152.7	210.0
19-1/8"	50-5/8"	4	210.0	210.0
26-1/2"			210.0	210.0
37"			179.6	210.0
53-1/8"			125.7	169.5
19-1/8"	63"	6	210.0	210.0
26-1/2"			210.0	210.0
37"			203.8	210.0
53-1/8"			110.7	166.1
19-1/8"	72"	8	210.0	210.0
26-1/2"			210.0	210.0
37"			210.0	210.0
53-1/8"			104.1	156.1
19-1/8"	76"	8	210.0	210.0
26-1/2"			210.0	210.0
37"			210.0	210.0
53-1/8"			102.1	153.1

LOADS APPLY TO INSTALLATION TYPES A, B & C AND INTO ALUMINUM BUCKS FOR ALUMINUM BUCK INSTALLATION SEE SHEETS 13 AND 14.

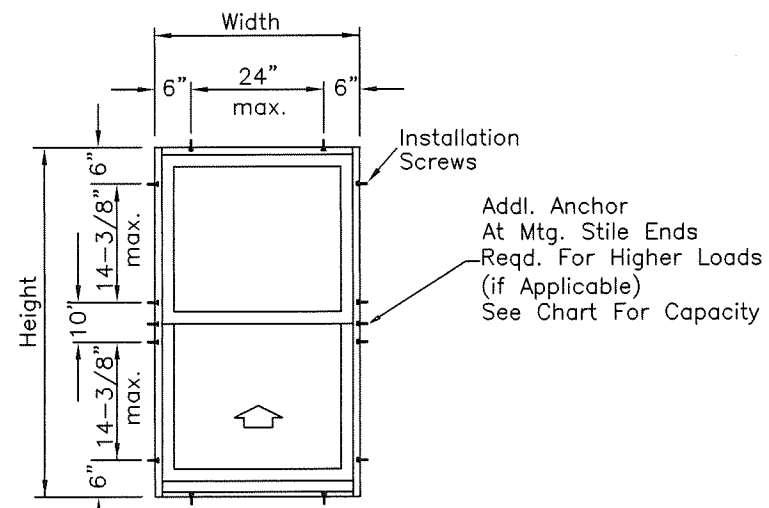

CGI Standard Hole Pattern

Refer to sheets 9 & 10 of 14 for description of installation types A - B - C

PRODUCT RENEWED as complying with the Florida Building Code  
 Acceptance No 20-0213-05  
 Expiration Date 5/5/25  
 By [Signature]  
 Miami Dade Product Control

PREPARED BY A. LYNN MILLER  
 1070 TECHNOLOGY DRIVE  
 N. VENICE, FL 34275  
 (941) 480-1600  
 REGISTRATION #29296

Rev. 2/10/2020  
 Drawn By ALAN KINNE  
 No. SH360LM-NOA  
 Sheet 11 OF 14  
 Title DESIGN LOAD TABLES  
 Series SH360

**WINDOOR**<sup>®</sup>  
 INCORPORATED  
 7500 AMSTERDAM DRIVE  
 ORLANDO, FL 32832  
 (407) 481-8400

SERIES "360" ALUM SINGLE HUNG WDW (LMI/SMI)  
 DESIGN LOAD TABLES

ANTHONY LYNN MILLER  
 LICENSE  
 No. 58705  
 2/10/20  
 STATE OF FLORIDA  
 PROFESSIONAL ENGINEER

A. LYNN MILLER, P.E.  
 P.E.# 58705

## Vertical Mullion Performance

$$\text{Tributary Width} = \frac{W1 + W2}{2}$$

For Window Performance, refer to sheets 5 or 7

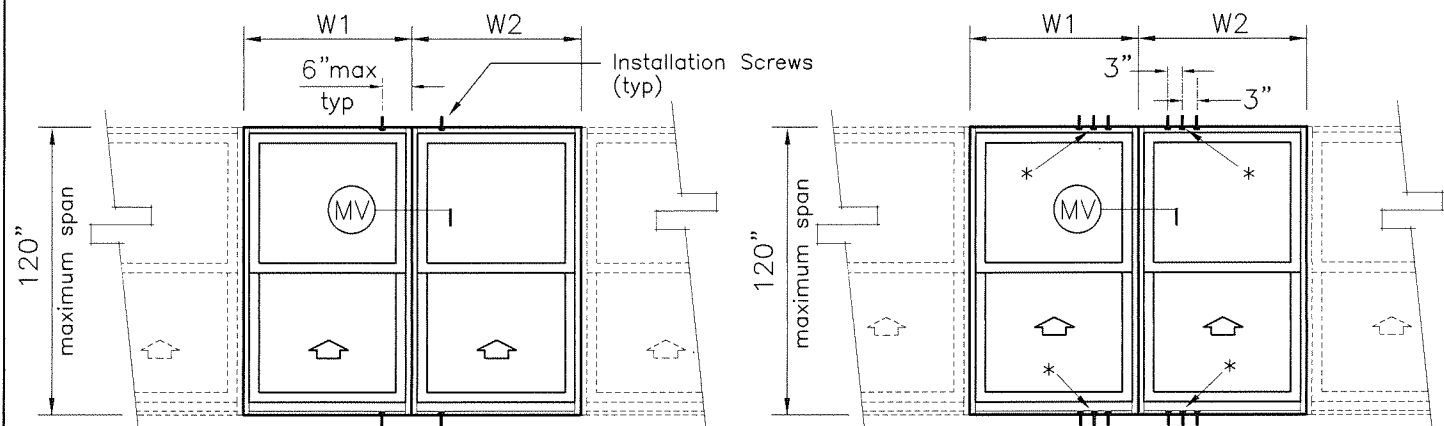

Multiple Opening  
(2 or more windows)  
w/ 1 screw on each side of mullion  
Standard Installation

Multiple Opening  
(2 or more windows)  
w/ 2 or 3 screws on each side of mullion  
High Load Installation  
(\* = additional holes to be drilled by installer)

## Horizontal Mullion Performance

For Window Performance, refer to sheets 5 or 7

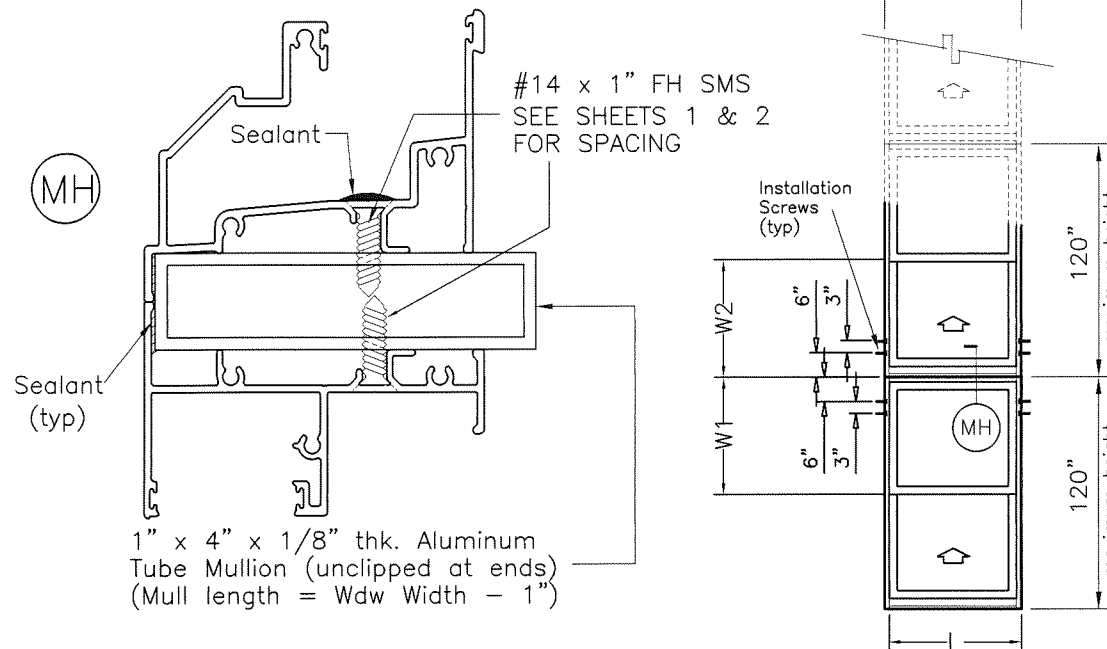

1" x 4" x 1/8" thk. Aluminum  
Tube Mullion (unclipped at ends)  
(Mull length = Wdw Width - 1")

1" x 4" x 1/8" thk. Aluminum  
Tube Mullion (6063-T6)  
(unclipped at ends)  
(Mull length = Wdw Height - 1")

#14 x 3/4" FH SMS  
SEE SHEETS 1 & 2  
FOR SPACING

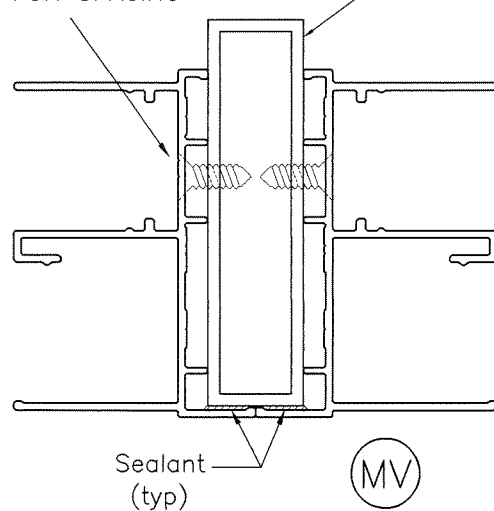

MULLION DESIGN LOAD CAPACITY - PSF				
WINDOW DIMS.		ONE ANCHOR EACH SIDE	TWO ANCHORS EACH SIDE	THREE ANCHORS EACH SIDE
WIDTH	HEIGHT	EXT.(+) & INT.(-)	EXT.(+) & INT.(-)	EXT.(+) & INT.(-)
24"	48"	150.0	210.0	210.0
30"		130.9	210.0	210.0
32"		126.6	210.0	210.0
36"		120.0	210.0	210.0
42"		114.5	210.0	210.0
48"		112.5	210.0	210.0
54"	112.5	210.0	210.0	
24"	60"	112.5	210.0	210.0
30"		96.0	192.0	210.0
32"		92.0	184.1	210.0
36"		85.7	171.4	210.0
42"		79.1	158.2	210.0
48"		75.0	150.0	210.0
54"	72.7	145.5	210.0	
24"	72"	90.0	180.0	210.0
30"		75.8	151.6	210.0
32"		72.3	144.6	210.0
36"		66.7	133.3	197.9
42"		60.5	121.0	175.4
48"		56.3	112.5	159.8
54"	53.3	106.7	149.0	
24"	84"	75.0	150.0	202.2
30"		62.6	125.2	164.2
32"		59.6	119.1	154.8
36"		54.5	109.1	139.5
42"		49.0	98.0	122.4
48"		45.0	90.0	110.0
54"	42.1	84.2	101.2	

MULLION DESIGN LOAD CAPACITY - PSF				
WINDOW DIMS.		ONE ANCHOR EACH SIDE	TWO ANCHORS EACH SIDE	THREE ANCHORS EACH SIDE
WIDTH	HEIGHT	EXT.(+) & INT.(-)	EXT.(+) & INT.(-)	EXT.(+) & INT.(-)
24"	96"	64.3	128.6	142.1
30"		53.3	106.7	115.3
32"		50.6	101.2	108.7
36"		46.2	92.3	97.8
42"		41.1	82.3	85.6
48"		37.5	75.0	76.8
54"	34.8	69.6	70.3	
24"	108"	56.3	99.3	99.3
30"		46.5	80.3	80.3
32"		44.0	75.6	75.6
36"		40.0	67.8	67.8
42"		35.5	59.1	59.1
48"		32.1	52.8	52.8
24"	120"	50.0	72.1	72.1
30"		41.1	58.2	58.2
32"		38.9	54.7	54.7
36"		35.3	49.0	49.0
42"		31.2	42.6	42.6

MULLION DESIGN LOAD CAPACITY - PSF				
WINDOW DIMS.		ONE ANCHOR EACH SIDE	TWO ANCHORS EACH SIDE	THREE ANCHORS EACH SIDE
WIDTH	HEIGHT	EXT.(+) & INT.(-)	EXT.(+) & INT.(-)	EXT.(+) & INT.(-)
53-1/8"	26"	210.0	210.0	210.0
19-1/8"		210.0	210.0	210.0
26-1/2"		194.6	210.0	210.0
37"	38-3/8"	176.2	210.0	210.0
53-1/8"		176.0	210.0	210.0
19-1/8"	50-5/8"	165.0	210.0	210.0
26-1/2"		130.9	210.0	210.0
37"		109.0	210.0	210.0
53-1/8"	63"	101.1	202.3	210.0
19-1/8"		126.8	210.0	210.0
26-1/2"		98.3	196.6	210.0
37"	72"	78.7	157.4	210.0
53-1/8"		67.0	133.9	200.9
19-1/8"		108.5	210.0	210.0
26-1/2"	76"	83.2	166.5	210.0
37"		65.5	130.9	193.5
53-1/8"		53.7	107.4	150.3
19-1/8"	76"	102.0	204.0	210.0
26-1/2"		77.9	155.9	210.0
37"		60.9	121.8	170.9
53-1/8"	76"	49.3	98.7	131.1

PRODUCT RENEWED  
as complying with the Florida  
Building Code  
Acceptance No. 20-0213.05  
Expiration Date 5/5/25  
By: [Signature]  
Miami Dade Product Control

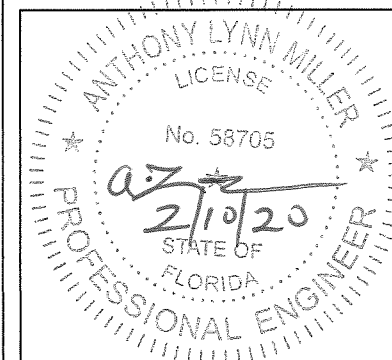

A. LYNN MILLER, P.E.  
P.E.# 58705

PREPARED BY A. LYNN MILLER  
1070 TECHNOLOGY DRIVE  
N. VENICE, FL 34275  
(941) 480-1600  
REGISTRATION #29296

**WINDOOR**  
INCORPORATED  
7500 AMSTERDAM DRIVE  
ORLANDO, FL 32832  
(407) 481-8400

SERIES "360" ALUM SINGLE HUNG WDW (LMI/SMI) 2/10/2020

MULLION DESIGN LOAD TABLES  
ALAN KINNE  
SH360LM-NOA

12 OF 14  
SH360



**PERFORMANCE VALUES OF ALUMINUM BUCK INSTALLATION ANCHORS**  
EXT.(+) & INT.(-)

WINDOW DIMS.		ANCHOR SPACING INTO CONC.		ANCHOR SPACING INTO HOLLOW BLOCK		ANCHOR SPACING INTO WOOD	
WIDTH	HEIGHT	16" O.C.	8" O.C.	16" O.C.	8" O.C.	16" O.C.	8" O.C.
24"	48"	210.0	210.0	178.7	210.0	210.0	210.0
30"		210.0	210.0	155.9	210.0	210.0	210.0
32"		210.0	210.0	150.8	210.0	210.0	210.0
36"		210.0	210.0	142.9	210.0	210.0	210.0
42"		205.7	210.0	131.3	204.2	176.3	210.0
48"		205.7	210.0	131.3	201.0	180.0	210.0
54"	168.0	210.0	107.2	187.6	144.0	210.0	
24"	60"	210.0	210.0	134.0	210.0	210.0	210.0
30"		179.2	210.0	114.3	200.1	210.0	210.0
32"		171.8	210.0	109.6	191.9	210.0	210.0
36"		160.0	210.0	102.1	178.7	210.0	210.0
42"		147.7	210.0	94.2	164.9	176.3	210.0
48"		140.0	210.0	89.3	156.3	180.0	210.0
54"	135.8	210.0	86.6	151.6	142.2	210.0	
24"	72"	210.0	210.0	134.0	210.0	210.0	210.0
30"		176.8	210.0	112.8	203.1	210.0	210.0
32"		168.8	210.0	107.7	193.8	210.0	210.0
36"		155.6	210.0	99.3	178.7	210.0	210.0
42"		141.2	210.0	90.1	162.2	176.3	210.0
48"		131.3	210.0	83.8	150.8	180.0	210.0
54"	124.4	210.0	79.4	142.9	142.2	210.0	
24"	84"	210.0	210.0	134.0	210.0	210.0	210.0
30"		175.3	210.0	111.9	186.4	210.0	210.0
32"		166.8	210.0	106.4	177.4	210.0	210.0
36"		152.7	210.0	97.5	162.4	210.0	210.0
42"		137.1	210.0	87.5	145.9	176.3	210.0
48"		126.0	210.0	80.4	134.0	180.0	210.0
54"	117.9	196.5	75.2	125.4	142.2	210.0	
24"	96"	210.0	210.0	134.0	210.0	210.0	210.0
30"		174.2	210.0	111.2	190.6	210.0	210.0
32"		165.4	210.0	105.5	180.9	210.0	210.0
36"		150.8	210.0	96.2	164.9	210.0	210.0
42"		134.4	210.0	85.8	147.0	176.3	210.0
48"		122.5	210.0	78.2	134.0	180.0	210.0
54"	113.6	194.8	72.5	124.3	142.2	210.0	
24"	108"	183.8	210.0	117.3	210.0	210.0	210.0
30"		151.7	210.0	96.8	179.8	210.0	210.0
32"		143.8	210.0	91.8	170.4	210.0	210.0
36"		130.7	210.0	83.4	154.8	210.0	210.0
42"		115.9	210.0	73.9	137.3	176.3	210.0
48"		105.0	195.0	67.0	124.4	180.0	210.0
24"	120"	186.7	210.0	119.1	210.0	210.0	210.0
30"		153.6	210.0	98.0	183.8	210.0	210.0
32"		145.4	210.0	92.8	173.9	210.0	210.0
36"		131.8	210.0	84.1	157.6	210.0	210.0
42"		116.4	210.0	74.3	139.2	176.3	210.0

**PERFORMANCE VALUES OF ALUMINUM BUCK INSTALLATION ANCHORS**  
EXT.(+) & INT.(-)

WINDOW DIMS.		ANCHOR SPACING INTO CONC.		ANCHOR SPACING INTO HOLLOW BLOCK		ANCHOR SPACING INTO WOOD	
WIDTH	HEIGHT	16" O.C.	8" O.C.	16" O.C.	8" O.C.	16" O.C.	8" O.C.
19-1/8"	26"	210.0	210.0	210.0	210.0	210.0	210.0
26-1/2"		210.0	210.0	210.0	210.0	210.0	210.0
37"		210.0	210.0	185.5	210.0	210.0	210.0
53-1/8"		210.0	210.0	148.0	210.0	198.8	210.0
19-1/8"	38-3/8"	210.0	210.0	210.0	210.0	210.0	210.0
26-1/2"		210.0	210.0	173.9	210.0	210.0	210.0
37"		210.0	210.0	157.4	210.0	210.0	210.0
53-1/8"		185.8	210.0	118.5	207.4	159.2	210.0
19-1/8"	50-5/8"	210.0	210.0	196.6	210.0	210.0	210.0
26-1/2"		210.0	210.0	155.9	210.0	210.0	210.0
37"		203.5	210.0	129.9	194.8	210.0	210.0
53-1/8"		171.8	210.0	109.6	180.7	147.3	210.0
19-1/8"	63"	210.0	210.0	188.8	210.0	210.0	210.0
26-1/2"		210.0	210.0	146.4	210.0	210.0	210.0
37"		183.7	210.0	117.2	187.5	210.0	210.0
53-1/8"		156.2	210.0	99.7	159.5	146.9	210.0
19-1/8"	72"	210.0	210.0	161.6	210.0	210.0	210.0
26-1/2"		194.2	210.0	123.9	210.0	210.0	210.0
37"		152.8	210.0	97.5	175.5	210.0	210.0
53-1/8"		125.3	210.0	79.9	143.9	146.9	210.0
19-1/8"	76"	210.0	210.0	151.9	210.0	210.0	210.0
26-1/2"		181.9	210.0	116.0	208.9	210.0	210.0
37"		142.1	210.0	90.7	163.3	210.0	210.0
53-1/8"		115.1	207.3	73.5	132.2	146.9	210.0

**ALUMINUM BUCK FRAMING DETAILS**

REFER TO SHEETS 3 THRU 9 FOR WINDOW CAPACITIES  
USE LOWER APPLICABLE VALUES.

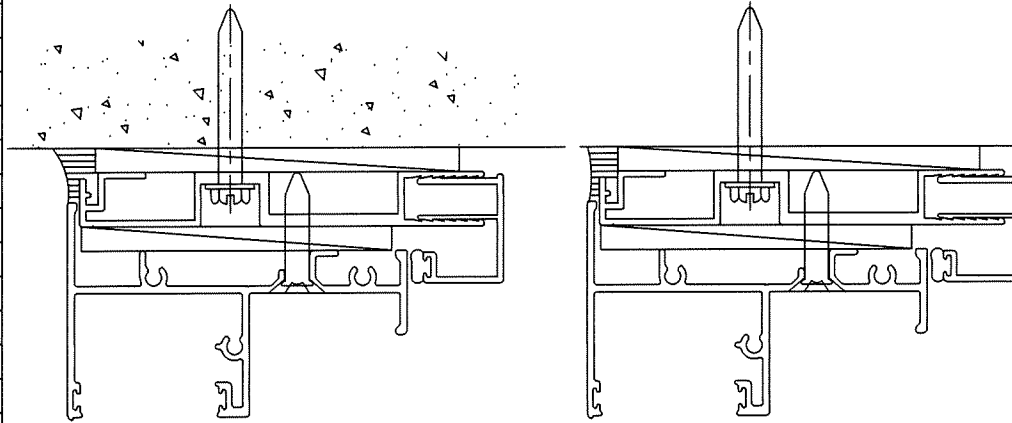

#14 SMS  
AT 6" FROM ENDS  
AND 24" O.C. MAX. AT  
HEAD & SILL AND 14-3/8"  
O.C. MAX AT JAMBS

#14 SMS  
AT 6" FROM ENDS  
AND 24" O.C. MAX. AT  
HEAD & SILL AND 14-3/8"  
O.C. MAX AT JAMBS

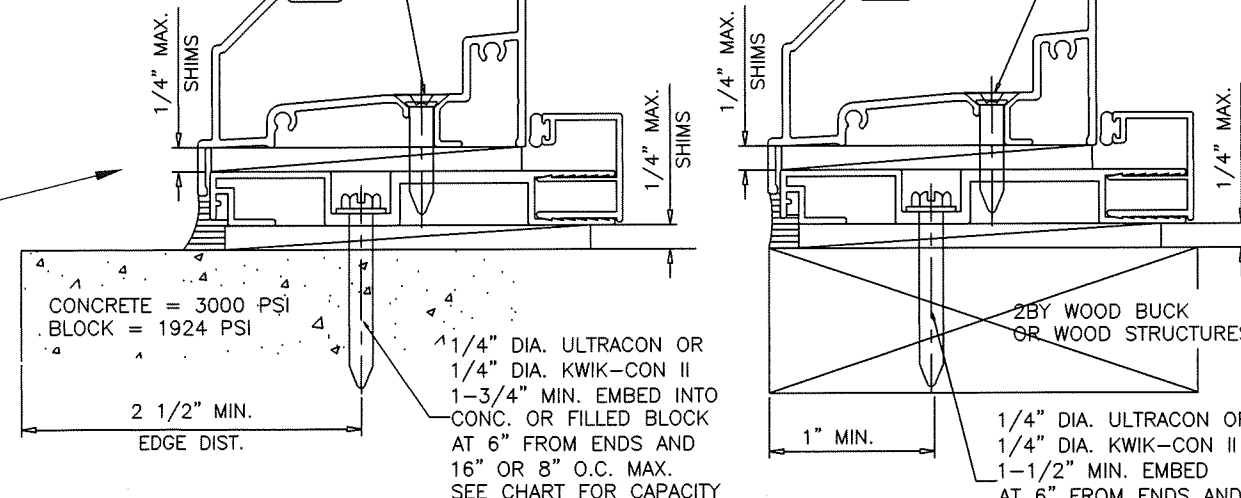
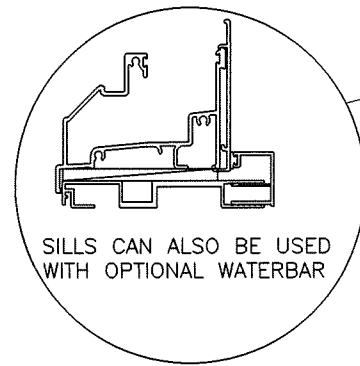

CONCRETE = 3000 PSI  
BLOCK = 1924 PSI

1/4" DIA. ULTRACON OR  
1/4" DIA. KWIK-CON II  
1-3/4" MIN. EMBED INTO  
CONC. OR FILLED BLOCK  
AT 6" FROM ENDS AND  
16" OR 8" O.C. MAX.  
SEE CHART FOR CAPACITY

2BY WOOD BUCK  
OR WOOD STRUCTURES

1/4" DIA. ULTRACON OR  
1/4" DIA. KWIK-CON II  
1-1/2" MIN. EMBED  
AT 6" FROM ENDS AND  
16" OR 8" O.C. MAX.  
SEE CHART FOR CAPACITY

**TYPICAL INSTALLATION DETAIL**  
ON ALL FOUR SIDES/USING ALUMINUM BUCK SYSTEM

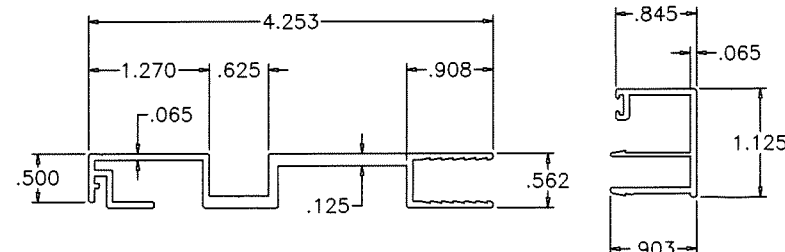

ALUMINUM BUCK  
6063-T6

OPTIONAL COVER  
6063-T6

PRODUCT RENEWED  
as complying with the Florida  
Building Code  
Acceptance No 20-0213-05  
Expiration Date 5/31/35  
By *Anthony Lynn Miller*  
Miami Dade Product Control

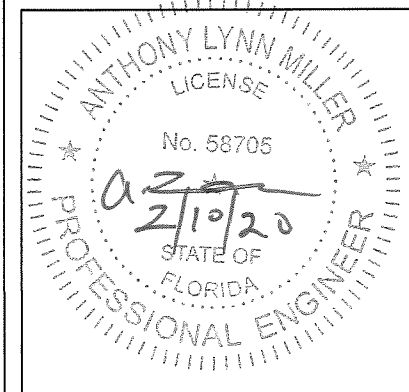

A. LYNN MILLER, P.E.  
P.E.# 58705

Revision:

<b>WINDOOR</b> INCORPORATED 7500 AMSTERDAM DRIVE ORLANDO, FL 32832 (407) 481-8400	PREPARED BY A. LYNN MILLER 1070 TECHNOLOGY DRIVE N. VENICE, FL 34275 (941) 480-1600 REGISTRATION #29296	2/10/2020 Date	ALAN KINNE By	SH360LM-NOA DWG No.
	SERIES "360" ALUM SINGLE HUNG WDW (LMI/SMI) Title	ALUMINUM BUCK Sheet	13 OF 14 Sheet	SH360 Series/Desc.

**PERFORMANCE VALUES  
OF ALUMINUM BUCK  
INSTALLATION ANCHORS**  
EXT.(+) & INT.(-)

WINDOW DIMS.		ANCHORS INTO HOLLOW BLOCK				ANCHORS INTO CONC.				ANCHORS INTO WOOD				
WIDTH	HEIGHT	CLUSTER OF 2	CLUSTER OF 4	CLUSTER OF 6	CLUSTER OF 8	CLUSTER OF 2	CLUSTER OF 4	CLUSTER OF 6	CLUSTER OF 8	CLUSTER OF 2	CLUSTER OF 4	CLUSTER OF 6	CLUSTER OF 8	
24"	48"	89.3	178.7	210.0	210.0	140.0	210.0	210.0	210.0	120.0	210.0	210.0	210.0	
30"		78.0	155.9	210.0	210.0	122.2	210.0	210.0	210.0	104.7	209.5	210.0	210.0	
32"		75.4	150.8	210.0	210.0	118.1	210.0	210.0	210.0	101.3	202.5	210.0	210.0	
36"		71.5	142.9	210.0	210.0	112.0	210.0	210.0	210.0	96.0	192.0	210.0	210.0	
42"		68.1	136.1	204.2	210.0	106.7	210.0	210.0	210.0	91.4	182.9	210.0	210.0	
48"		67.0	134.0	201.0	210.0	105.0	210.0	210.0	210.0	90.0	180.0	210.0	210.0	
54"		67.0	134.0	201.0	210.0	105.0	210.0	210.0	210.0	90.0	180.0	210.0	210.0	
24"		60"	67.0	134.0	201.0	210.0	105.0	210.0	210.0	210.0	90.0	180.0	210.0	210.0
30"	57.2		114.3	171.5	210.0	89.6	179.2	210.0	210.0	76.8	153.6	210.0	210.0	
32"	54.8		109.6	164.5	210.0	85.9	171.8	210.0	210.0	73.6	147.3	210.0	210.0	
36"	51.0		102.1	153.1	204.2	80.0	160.0	210.0	210.0	68.6	137.1	205.7	210.0	
42"	47.1		94.2	141.4	188.5	73.8	147.7	210.0	210.0	63.3	126.6	189.9	210.0	
48"	44.7		89.3	134.0	178.7	70.0	140.0	210.0	210.0	60.0	120.0	180.0	210.0	
54"	43.3		86.6	129.9	173.3	67.9	135.8	203.6	210.0	58.2	116.4	174.5	210.0	
24"	72"		53.6	107.2	160.8	210.0	84.0	168.0	210.0	210.0	72.0	144.0	210.0	210.0
30"		45.1	90.3	135.4	180.5	70.7	141.5	210.0	210.0	60.6	121.3	181.9	210.0	
32"		43.1	86.1	129.2	172.3	67.5	135.0	202.5	210.0	57.9	115.7	173.6	210.0	
36"		39.7	79.4	119.1	158.8	62.2	124.4	186.7	210.0	53.3	106.7	160.0	210.0	
42"		36.0	72.1	108.1	144.1	56.5	112.9	169.4	210.0	48.4	96.8	145.2	193.6	
48"		33.5	67.0	100.5	134.0	52.5	105.0	157.5	210.0	45.0	90.0	135.0	180.0	
54"		31.8	63.5	95.3	127.1	49.8	99.6	149.3	199.1	42.7	85.3	128.0	170.7	
24"		84"	44.7	89.3	134.0	178.7	70.0	140.0	210.0	210.0	60.0	120.0	180.0	210.0
30"	37.3		74.6	111.9	149.1	58.4	116.9	175.3	210.0	50.1	100.2	150.3	200.3	
32"	35.5		70.9	106.4	141.9	55.6	111.2	166.8	210.0	47.6	95.3	142.9	190.6	
36"	32.5		65.0	97.5	129.9	50.9	101.8	152.7	203.6	43.6	87.3	130.9	174.5	
42"	29.2		58.3	87.5	116.7	45.7	91.4	137.1	182.9	39.2	78.4	117.6	156.7	
48"	26.8		53.6	80.4	107.2	42.0	84.0	126.0	168.0	36.0	72.0	108.0	144.0	
54"	25.1		50.2	75.2	100.3	39.3	78.6	117.9	157.2	33.7	67.4	101.1	134.7	
24"	96"		38.3	76.6	114.9	153.1	60.0	120.0	180.0	210.0	51.4	102.9	154.3	205.7
30"		31.8	63.5	95.3	127.1	49.8	99.6	149.3	199.1	42.7	85.3	128.0	170.7	
32"		30.1	60.3	90.4	120.6	47.2	94.5	141.7	189.0	40.5	81.0	121.5	162.0	
36"		27.5	55.0	82.5	109.9	43.1	86.2	129.2	172.3	36.9	73.8	110.8	147.7	
42"		24.5	49.0	73.5	98.0	38.4	76.8	115.2	153.6	32.9	65.8	98.7	131.7	
48"		22.3	44.7	67.0	89.3	35.0	70.0	105.0	140.0	30.0	60.0	90.0	120.0	
54"		20.7	41.4	62.1	82.9	32.5	64.9	97.4	129.9	27.8	55.7	83.5	111.3	
24"		108"	33.5	67.0	100.5	134.0	52.5	105.0	157.5	210.0	45.0	90.0	135.0	180.0
30"	27.7		55.3	83.0	110.7	43.4	86.7	130.1	173.4	37.2	74.3	111.5	148.6	
32"	26.2		52.4	78.7	104.9	41.1	82.2	123.3	164.3	35.2	70.4	105.7	140.9	
36"	23.8		47.6	71.5	95.3	37.3	74.7	112.0	149.3	32.0	64.0	96.0	128.0	
42"	21.1		42.2	63.4	84.5	33.1	66.2	99.3	132.4	28.4	56.7	85.1	113.5	
48"	19.1		38.3	57.4	76.6	30.0	60.0	90.0	120.0	25.7	51.4	77.1	102.9	
24"	120"		29.8	59.6	89.3	119.1	46.7	93.3	140.0	186.7	40.0	80.0	120.0	160.0
30"			24.5	49.0	73.5	98.0	38.4	76.8	115.2	153.6	32.9	65.8	98.7	131.7
32"		23.2	46.4	69.6	92.8	36.3	72.7	109.0	145.4	31.2	62.3	93.5	124.6	
36"		21.0	42.0	63.1	84.1	32.9	65.9	98.8	131.8	28.2	56.5	84.7	112.9	
42"		18.6	37.1	55.7	74.3	29.1	58.2	87.3	116.4	24.9	49.9	74.8	99.7	

**ANCHORS AT  
ALUMINUM BUCK FRAMING  
(AT MULLION ENDS)**

FOR WINDOW ANCHORING TO  
ALUMINUM BUCKS USE #14 SCREWS  
SPACED AS PER SHEETS 11 & 12.

**PERFORMANCE VALUES  
OF ALUMINUM BUCK  
INSTALLATION ANCHORS**  
EXT.(+) & INT.(-)

WINDOW DIMS.		ANCHORS INTO HOLLOW BLOCK				ANCHORS INTO CONC.				ANCHORS INTO WOOD			
WIDTH	HEIGHT	CLUSTER OF 2	CLUSTER OF 4	CLUSTER OF 6	CLUSTER OF 8	CLUSTER OF 2	CLUSTER OF 4	CLUSTER OF 6	CLUSTER OF 8	CLUSTER OF 2	CLUSTER OF 4	CLUSTER OF 6	CLUSTER OF 8
19-1/8"	26"	210.0	210.0	210.0	210.0	210.0	210.0	210.0	210.0	210.0	210.0	210.0	210.0
26-1/2"		210.0	210.0	210.0	210.0	210.0	210.0	210.0	210.0	210.0	210.0	210.0	210.0
37"		210.0	210.0	210.0	210.0	210.0	210.0	210.0	210.0	210.0	210.0	210.0	210.0
53-1/8"		210.0	210.0	210.0	210.0	210.0	210.0	210.0	210.0	210.0	210.0	210.0	210.0
19-1/8"	38-3/8"	140.1	210.0	210.0	210.0	210.0	210.0	210.0	210.0	188.2	210.0	210.0	210.0
26-1/2"		115.9	210.0	210.0	210.0	181.7	210.0	210.0	210.0	155.7	210.0	210.0	210.0
37"		105.0	209.9	210.0	210.0	164.5	210.0	210.0	210.0	141.0	210.0	210.0	210.0
53-1/8"	50-5/8"	104.8	209.6	210.0	210.0	164.3	210.0	210.0	210.0	140.8	210.0	210.0	210.0
19-1/8"		98.3	196.6	210.0	210.0	154.0	210.0	210.0	210.0	132.0	210.0	210.0	210.0
26-1/2"		77.9	155.9	210.0	210.0	122.1	210.0	210.0	210.0	104.7	209.4	210.0	210.0
37"		64.9	129.9	194.8	210.0	101.8	203.5	210.0	210.0	87.2	174.5	210.0	210.0
53-1/8"	63"	60.2	120.5	180.7	210.0	94.4	188.8	210.0	210.0	80.9	161.8	210.0	210.0
19-1/8"		75.5	151.0	210.0	210.0	118.4	210.0	210.0	210.0	101.4	202.9	210.0	210.0
26-1/2"		58.5	117.1	175.6	210.0	91.7	183.5	210.0	210.0	78.6	157.3	210.0	210.0
37"	72"	46.9	93.8	140.6	187.5	73.5	146.9	210.0	210.0	63.0	125.9	188.9	210.0
53-1/8"		39.9	79.7	119.6	159.5	62.5	125.0	187.5	210.0	53.6	107.1	160.7	210.0
19-1/8"		64.6	129.3	193.9	210.0	101.3	202.6	210.0	210.0	86.8	173.7	210.0	210.0
26-1/2"	76"	49.6	99.2	148.7	198.3	77.7	155.4	210.0	210.0	66.6	133.2	199.8	210.0
37"		39.0	78.0	117.0	156.0	61.1	122.2	183.3	210.0	52.4	104.8	157.1	209.5
53-1/8"	76"	32.0	64.0	95.9	127.9	50.1	100.2	150.3	200.4	43.0	85.9	128.9	171.8
19-1/8"		60.7	121.5	182.2	210.0	95.2	190.4	210.0	210.0	81.6	163.2	210.0	210.0
26-1/2"		46.4	92.8	139.2	185.7	72.7	145.5	210.0	210.0	62.3	124.7	187.0	210.0
37"	76"	36.3	72.6	108.8	145.1	56.9	113.7	170.6	210.0	48.7	97.5	146.2	194.9
53-1/8"		29.4	58.8	88.2	117.6	46.1	92.1	138.2	184.2	39.5	79.0	118.4	157.9

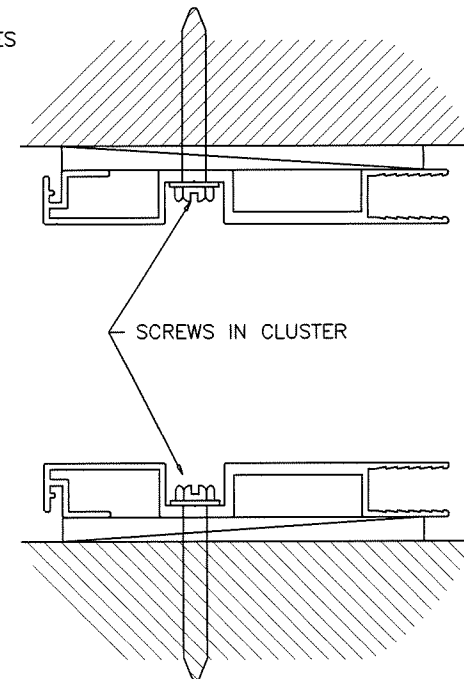
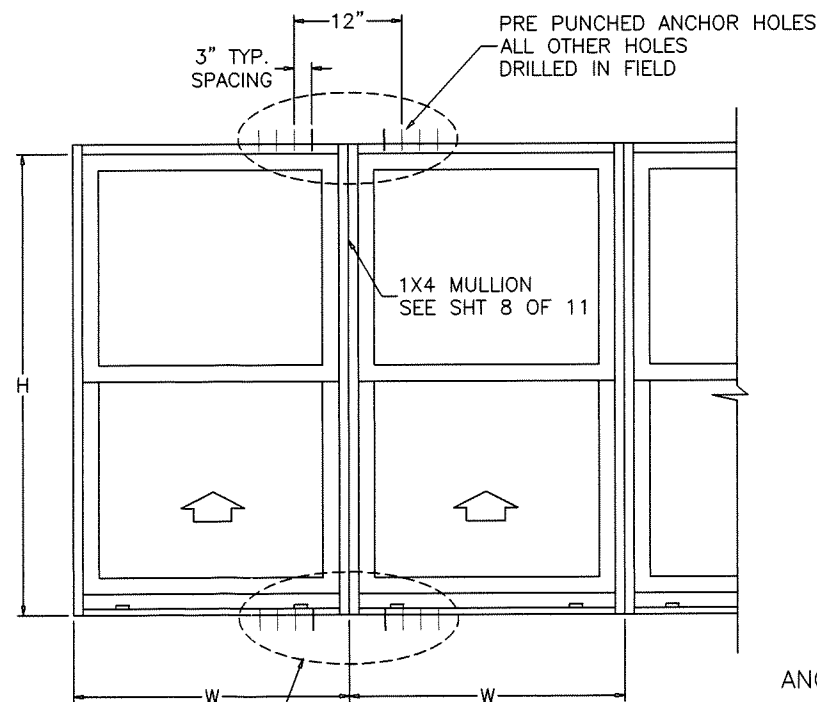

CLUSTER OF 2, 4, 6 OR 8 ANCHORS  
(SEE CHARTS ABOVE). ALL OTHER BUCK  
ANCHORS AS PER SHEET 13.  
(CLUSTER OF 8 BEING SHOWN)

NOTE: ALUMINUM BUCKS ARE SUPPLIED WITH  
CLUSTER OF 2 (1 SCREW HOLE PER SIDE) STANDARD.  
EXTRA HOLES MUST BE FIELD DRILLED IF REQUIRED.

**PRODUCT RENEWED**  
as complying with the Florida  
Building Code  
Acceptance No. 20-02.13.05  
Expiration Date 04/05/2025  
By *Anthony Lynn Miller*  
Miami Dade Product Control

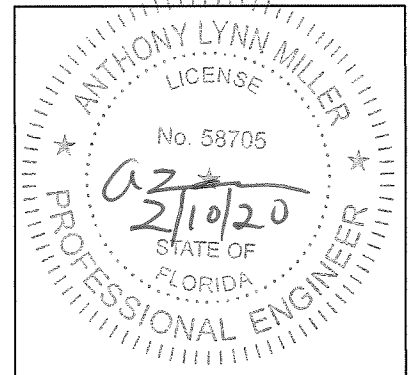

A. LYNN MILLER, P.E.  
P.E.# 58705

Revision:

PREPARED BY A. LYNN MILLER 1070 TECHNOLOGY DRIVE N. VENICE, FL 34275 (941) 480-1600 REGISTRATION #29296	SERIES "360" ALUM SINGLE HUNG WDW (LMI/SMI) 2/10/2020	Date	2/10/2020
		By	ALAN KINNE
<b>WINDOOR</b> INCORPORATED 7500 AMSTERDAM DRIVE ORLANDO, FL 32832 (407) 481-8400	ALUMINUM BUCK SH360	DWG No.	SH360LM-NOA
		Sheet	14 OF 14