

CITY OF CANTON EV CHARGING STATIONS

EAST TUSCARAWAS STREET (PARCEL #246570)
CANTON, OH. 44702

DRAWING INDEX

<u>DRAWING DESCRIPTION</u>	<u>DWG NO.</u>
TITLE SHEET	E001
ELECTRICAL SITE PLAN AND DETAILS	E100
POWER RISER, PANEL SCHEDULES AND SPECIFICATIONS	E200



2 WORKING DAYS
BEFORE YOU DIG



CALL TOLL FREE 800-362-2764
OHIO UTILITIES PROTECTION SERVICE

THE CONTRACTOR SHALL VERIFY THE
LOCATIONS OF UNDERGROUND UTILITIES
BY CALLING O.U.P.S. (800) 362-2764 AT LEAST 48
HOURS PRIOR TO DIGGING. THE CONTRACTOR
SHALL TAKE ALL NECESSARY STEPS TO PROTECT
THE UNDERGROUND UTILITIES FROM DAMAGE BY
CONTRACTOR'S EMPLOYEES OR SUBCONTRACTORS.

PREPARED BY:

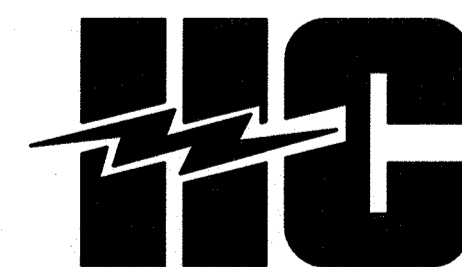

HILSCHER-CLARKE
ELECTRICAL CONTRACTORS AND ENGINEERS
519 4TH STREET N.W. CANTON, OHIO 44703
PHONE: 330-452-9808 FAX: 330-452-5867
EMAIL: ENGR@HILSCHER-CLARKE.COM

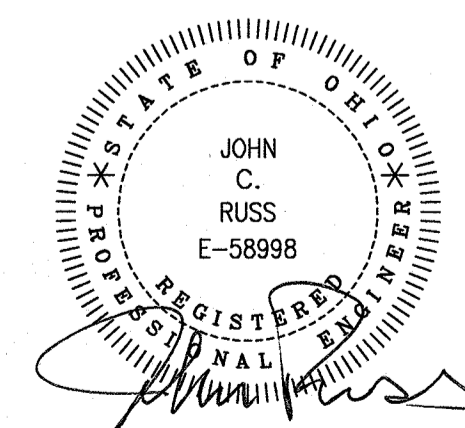

SCOPE OF WORK

- THE ELECTRICAL CONTRACTOR SHALL PROVIDE ALL LABOR, EQUIPMENT, SUPPLIES, MATERIALS, TOOLS, PERMITS, ETC. AND SHALL PERFORM ALL OPERATIONS NECESSARY FOR THE COMPLETE INSTALLATION OF THE ELECTRICAL WORK ON THIS PROJECT, COMPLETE IN STRICT ACCORDANCE WITH THE SPECIFICATION AND APPLICABLE DRAWINGS, AND READY FOR USE.
- ALL ITEMS OF LABOR, MATERIALS AND EQUIPMENT NOT SPECIFICALLY MENTIONED HEREIN OR SHOWN ON THE PLANS, BUT INCIDENTAL TO OR REQUIRED FOR, THE COMPLETE INSTALLATION AND PROPER OPERATION OF THE WORK, SHALL BE FURNISHED AS IF CALLED IN DETAIL BY THE SPECIFICATION OR DRAWINGS. WHEREVER THE WORD "PROVIDE" IS USED HEREIN, IT SHALL BE INTERPRETED AS "FURNISH AND INSTALL".
- THE WORK OF THIS SECTION IS TO INCLUDE BUT IS NOT LIMITED TO THE FOLLOWING:
 - POWER DISTRIBUTION SYSTEM INCLUDING METERING, PANEL BOARDS, FEEDERS, BRANCH CIRCUITS, ETC.
 - ALL STRUCTURAL MEMBERS REQUIRED, IN ADDITION TO ANY SHOWN ON THE STRUCTURAL DRAWINGS FOR PROPER SUPPORT OF EQUIPMENT UNDER THIS SECTION.
 - ELECTRICAL SERVICES SERVICES AS SHOWN AND AS COORDINATED WITH THE RESPECTIVE UTILITY CO. REPRESENTATIVES.

REFERENCE STANDARDS:

- IT IS THE INTENT OF THESE PLANS AND SPECIFICATIONS TO RESULT IN A COMPLETE ELECTRICAL INSTALLATION IN FULL ACCORDANCE WITH ALL REQUIREMENTS OF THE MOST CURRENT NATIONAL ELECTRICAL CODE, THE NATIONAL ELECTRICAL SAFETY CODE, THE STANDARDS OF THE NATIONAL BUREAU OF FIRE UNDERWRITERS, THE STATE OF OHIO BUILDING CODE, AND ALL LOCAL CODES AND ORDINANCES. IN THE EVENT ANY PORTIONS OF THE INSTALLATION SHOWN OR SPECIFIED FAIL TO MEET THESE REQUIREMENTS, IT SHALL BE THE ELECTRICAL CONTRACTOR'S RESPONSIBILITY TO ALTER THE LAYOUT TO MEET THE REQUIREMENTS OF THE GOVERNING CODE AND TO NOTIFY THE ARCHITECT OF SUCH CHANGES. IN THOSE PORTIONS OF THE PLANS AND SPECIFICATIONS WHERE INSTALLATION, SHOWN OR DESCRIBED, EXCEEDS THE REQUIREMENTS OF THE STATE AND LOCAL CODES, THE SPECIFICATIONS AND PLANS SHALL GOVERN.
- THE ENTIRE INSTALLATION THEREFORE SHALL COMPLY WITH ALL LAWS AND REQUIREMENTS APPLYING TO ELECTRICAL INSTALLATION IN EFFECT IN THE STATE OF OHIO. CHANGES REQUIRED BY THE INSPECTING AUTHORITIES TO MEET THESE CODES AND STANDARDS SHALL BE MADE BY THE ELECTRICAL CONTRACTOR AT HIS OWN EXPENSE.
- ALL MATERIAL AND EQUIPMENT BUILT INTO THE SCOPE OF WORK SHALL BEAR UNDERWRITER'S LABEL.

GENERAL REQUIREMENTS:

- PROVIDE OSHA SAFETY SIGN ON EACH PANEL BOARD DESCRIBING ARC FLASH HAZARDS AND NECESSARY WORKING CLEARANCE IN FRONT OF PANEL BOARDS.
- THE ELECTRICAL DRAWINGS, WHICH CONSTITUTE A PART OF THE CONTRACT, INDICATE THE GENERAL ARRANGEMENT OF CIRCUITS AND OUTLETS, LOCATION OF SWITCHES, PANEL BOARDS, CONDUIT AND OTHER WORK. THE ELECTRICAL CONTRACTOR SHALL OBTAIN EXACT LOCATIONS FROM THE OWNER PRIOR TO INSTALLATION AND ARRANGE HIS WORK ACCORDINGLY.
- THE ELECTRICAL CONTRACTOR SHALL VISIT THE SITE OF THE WORK AND FAMILIARIZE HIMSELF WITH ALL CONDITIONS AFFECTING THE WORK, AND THE SUBMISSION OF HIS PROPOSAL SHALL PRESUPPOSE HIS KNOWLEDGE OF ALL SUCH CONDITIONS AND PERFORMANCE OF ALL WORK REQUIRED FOR A COMPLETE AND CODE COMPLYING INSTALLATION.
- ELECTRICAL CONTRACTOR SHALL OBTAIN ALL PERMITS REQUIRED FOR THE COMPLETION OF THE WORK AND SHALL FURNISH TO THE OWNER, UPON COMPLETION, A CERTIFICATE OF FINAL INSPECTION.
- NO WORK SHALL START UNTIL WORKING DRAWINGS AND OTHER REQUIRED DOCUMENTS HAVE BEEN SUBMITTED TO THE DEPARTMENT HAVING AUTHORITY TO ISSUE CERTIFICATES OF APPROVAL AND HAVE BEEN SIGNED AND APPROVED.
- ALL WORKMANSHIP SHALL BE IN ACCORDANCE WITH THE BEST PRACTICES OF THE TRADE. ELECTRICAL WORK SHALL BE INSTALLED BY JOURNEYMEN ELECTRICIANS UNDER THE DIRECT SUPERVISION OF A COMPETENT FOREMAN.
- DEFINITIONS
 - "PROVIDE" IS DEFINED AS "FURNISH, INSTALL AND MAKE OPERATIONAL."
 - "RELOCATE" IS DEFINED AS "REMOVE EXISTING, INSTALL EXISTING IN DIFFERENT LOCATION AND MAKE OPERATIONAL."
 - "REPLACE" IS DEFINED AS "REMOVE EXISTING AND PROVIDE NEW IN SAME LOCATION."
 - "REINSTALL" IS DEFINED AS "REMOVE EXISTING, INSTALL EXISTING IN SAME LOCATION AND MAKE OPERATIONAL."
 - "REMOVE" IS DEFINED AS "REMOVE EXISTING INCLUDING CONDUIT AND WIRE BACK TO SOURCE".

FOR RECORD DRAWINGS:

- THE E.C. SHALL KEEP ONE SET OF THE CONTRACT WORKING DRAWINGS ON WHICH ANY CHANGES OR DEVIATIONS FROM THE CONTRACT DRAWINGS ARE RECORDED. AFTER COMPLETION OF THE PROJECT A COMPLETE SET OF RECORD DRAWINGS SHALL BE TURNED OVER TO THE ARCHITECT IN GOOD AND LEGIBLE CONDITION. THESE DRAWINGS SHALL BECOME A PERMANENT RECORD OF THE INSTALLATION AS CONSTRUCTED.

CONDUIT:

RMC (RIGID METAL CONDUIT):

- MINIMUM SIZE SHALL BE 1/2".
- RMC SHALL BE USED IN THE FOLLOWING LOCATIONS:
 - EXPOSED (OUTDOORS)
 - CONDUITS RISING FROM BELOW GRADE TO SURFACE MOUNTED ENCLOSURES

SCH40/SCH80 PVC (POLY VINYL CHLORIDE):

- MINIMUM SIZE SHALL BE 3/4".
- PVC SHALL BE USED IN THE FOLLOWING LOCATIONS:
 - BELOW GRADE
- PVC SHALL NOT BE USED IN THE FOLLOWING LOCATIONS:
 - ABOVE FINISHED GRADE, UNLESS NOTED OTHERWISE

CABLE AND WIRE:

- EXCEPT AS SPECIFICALLY DESIGNATED, OTHERWISE, NO WIRE SMALLER THAN NO. 12 AWG COPPER, 600 VOLT INSULATION UNLESS OTHERWISE NOTED ON DRAWINGS, SHALL BE USED. IN THE EVENT THAT SIZE IS NOT INDICATED FOR A FEEDER OR MOTOR RUN WHICH, OBVIOUSLY COULD NOT BE INTERPRETED AS NO. 12, THE WIRE SIZE SHALL CONFORM TO THE NATIONAL ELECTRICAL CODE SIZING FOR THE TYPE OR SERVICE INDICATED. BRANCH CIRCUIT HOMERUNS SHALL BE PVC AS SPECIFIED HEREIN.
- EXCEPT AS SPECIFIED OTHERWISE, INTERIOR & EXTERIOR WIRE FOR GENERAL BUILDING SERVICE FEEDERS SHALL BE THINWALL ALUMINUM OR COPPER AS NOTED ON THE DRAWINGS
- ALL HOMERUN BRANCH CIRCUITS EXCEEDING 100' IN LENGTH SHALL BE INCREASED IN SIZE TO NO. 10 AWG, MINIMUM.
- ALL CONNECTORS OF CABLE OR WIRE TO EQUIPMENT SHALL BE BY MEANS OF APPROVED SOLDER-LESS TYPE CONNECTORS. SPLICES AND TERMINATIONS FOR WIRE #8 AND LARGER SHALL BE MADE WITH MECHANICAL SPLICING DEVICES AND LUGS.
- PRESSURE CONNECTORS, CONSISTING OF CONE SHAPED COILED SPRINGS WITH INSULATED COVERS, CAN BE USED FOR CONDUCTORS #8 AND SMALLER.
- ALL CABLE SPLICES AND TERMINATIONS SHALL BE MADE IN ACCORDANCE WITH THE LATEST

APPROPRIATE 3M COMPANY RECOMMENDATIONS AND SPECIFICATIONS FOR TYPE, SIZE, AND VOLTAGE RATING OF THE SPECIFIED CABLES.

PANEL BOARDS:

- PANEL BOARDS SHALL BE CABINET ENCLOSED SAFETY "DEAD FRONT" TYPE, WITH SOLDER-LESS LUGS, AND WITH CIRCUIT BREAKER BRANCHES.
- PLUG IN TYPE OF CIRCUIT BREAKERS WILL NOT BE ACCEPTABLE.
- DOORS, COMPLETE WITH A TYPEWRITTEN DIRECTORY CARD OF THE CIRCUITS, SHALL BE FLUSH WITH TRIM.
- ALL PANEL BOARDS TO HAVE ALUMINUM BUSSING.
- THE MANUFACTURER USED FOR THE BASIS OF THIS DESIGN WAS SQ. D. CUTLER-HAMMER, SIEMENS, AND GE. ARE ACCEPTABLE MANUFACTURERS. HOWEVER, DUE TO SPACE RESTRICTIONS, E.C. WILL BE RESPONSIBLE FOR VERIFYING DIMENSIONS AND ENSURING PROPER CLEARANCES AS SHOWN ON DRAWINGS.
- ALL CIRCUIT BREAKERS SHALL BE HACR RATED.

GROUNDING:

- PROVIDE A PERMANENT AND CONTINUOUS COPPER GROUND WIRE FROM SERVICE ENTRANCE NEUTRAL TO WATER METER, WITH SUPPLEMENTAL GROUND ROD PER NATIONAL ELECTRICAL CODE, LATEST EDITION.
- SIZES AND TYPES OF GROUNDING CONDUCTORS, GROUNDING CLAMPS, BONDING JUMPERS, CONDUIT FITTINGS, AND METHODS OF SECURING SAME TO OBTAIN ELECTRICAL CONTINUITY AND EFFECTIVE CONTINUITY TO BE IN ACCORDANCE WITH ARTICLE 250 OF THE NATIONAL ELECTRICAL CODE.
- ALL CONDUITS SHALL INCLUDE AN EQUIPMENT GROUNDING CONDUCTOR SIZED IN ACCORDANCE WITH THE MOST CURRENT NATIONAL ELECTRICAL CODE, TABLE 250.122.
- METAL ENCLOSURES AND RACEWAYS FOR SERVICE CONDUCTORS AND EQUIPMENT SHALL BE GROUNDED PER ART. 250.80

EQUIPMENT IDENTIFICATION:

- PROVIDE NAMEPLATES ON ALL EQUIPMENT OF THE TYPE LISTED IN THE FOLLOWING SCHEDULE:
 - EXISTING PANEL BOARDS
 - NEW PANEL BOARDS
 - DISCONNECTS
 - TRANSFORMERS
 - MOTOR STARTERS
 - LIGHTING CONTACTORS
- LETTERING SHALL INCLUDE EQUIPMENT NAME, THE SPECIFIC UNIT NUMBER, ANY REFERENCE TO ON-OFF OR OTHER INSTRUCTIONS THAT ARE APPLICABLE.
- NAME PLATES SHALL BE LAMINATED PHENOLIC WITH A WHITE SURFACE AND BLACK CORE.

WARRANTY:

- MATERIALS, EQUIPMENT, AND INSTALLATION SHALL BE GUARANTEED FOR A PERIOD OF ONE YEAR FROM THE DATE OF ACCEPTANCE.

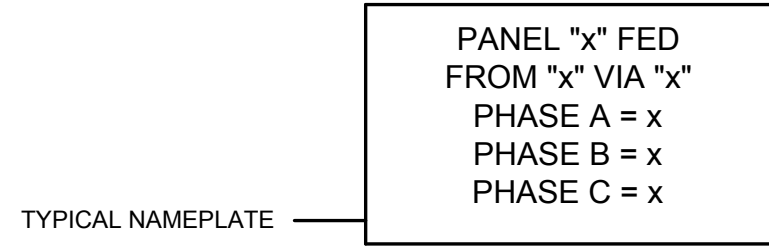

PANEL "A"										
120/208V, 3Ø, 4W., 600A MCB, 65KAIC, FULL CAPACITY NEUTRAL SEPARATE GROUND BUS, SURFACE MOUNTED NEMA 3R ENCLOSURE										
NO.	CIRCUIT DESCRIPTION	WATTS	C/B	A	B	C	C/B	WATTS	CIRCUIT DESCRIPTION	NO.
1	FUTURE 208V CHARGER	7200	40/2	•			40/2	7200	FUTURE 208V CHARGER	2
3										4
5	SPACE	20/1		•			500/3	125000	150KVA TRANSFORMER	6
7	SPACE	20/1		•						8
9	SPACE	20/1		•						10
11	SPACE	20/1		•			20/1		SPACE	12
13	SPACE	20/1		•			20/1		SPACE	14
15	SPACE	20/1		•			20/1		SPACE	16
17	SPACE	20/1		•			20/1		SPACE	18
SUBTOTAL		7200						132200	SUBTOTAL	
TOTAL LOAD - 139.4kW (387.0A)										

PANEL "B"										
480/277V, 3Ø, 4W., 200A MCB, 14KAIC, FULL CAPACITY NEUTRAL SEPARATE GROUND BUS, SURFACE MOUNTED NEMA 3R ENCLOSURE										
NO.	CIRCUIT DESCRIPTION	WATTS	C/B	A	B	C	C/B	WATTS	CIRCUIT DESCRIPTION	NO.
1	DC FAST CHARGER #1	62500	100/3	•			100/3	62500	DC FAST CHARGER #2	2
3										4
5										6
7	SPACE	20/1		•			20/1		SPACE	8
9	SPACE	20/1		•			20/1		SPACE	10
11	SPACE	20/1		•			20/1		SPACE	12
13	SPACE	20/1		•			20/1		SPACE	14
15	SPACE	20/1		•			20/1		SPACE	16
17	SPACE	20/1		•			20/1		SPACE	18
SUBTOTAL		62500						62500	SUBTOTAL	
TOTAL LOAD - 125.0kW (150.4A)										

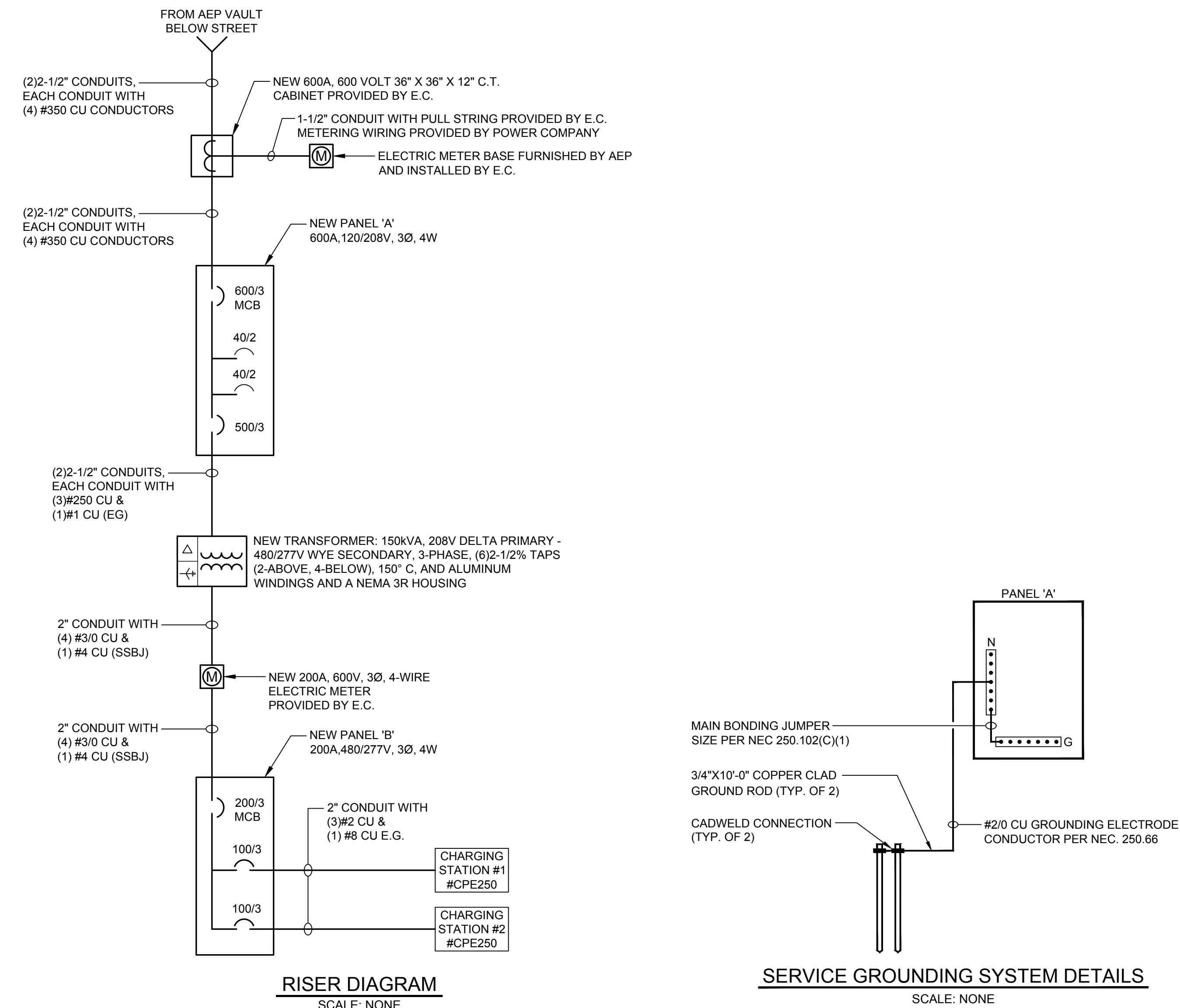

HILSCHER-CLARKE
ELECTRICAL CONTRACTORS AND ENGINEERS
519 4TH STREET N.W.
CANTON, OHIO 44703
PHONE: 330-452-9806
FAX: 330-452-6867
EMAIL: ENGR@HILSCHER-CLARKE.COM

ENGINEER'S SEAL

JOHN C. RUSS
E-58998
REGISTERED PROFESSIONAL ENGINEER

CITY OF CANTON

TUSCARAWAS STREET EAST (PARCEL #246570)
CANTON, OHIO 44702

PROJECT

EV CHARGING STATIONS

DRAWING ISSUES/REVISIONS

DESCRIPTION	DATE
ORIGINAL ISSUE	03/24/20

DRAWN BY: RWL CHECKED BY: JCR
JOB NO. 121452 SCALE: AS NOTED

TITLE

POWER RISER, PANEL SCHEDULES AND SPECIFICATIONS

SHEET

E200

Express 250

Specifications and Ordering Information



Express 250

Ordering Information

The order codes below represent specific product configurations. Other product options are available. Please contact ChargePoint Sales for information and order codes.

Hardware

Description		Order Code
Model	Express 250 Station includes 2x Power Modules, 1x CCS1 cable, 1x CHAdeMO cable (NA)	CPE250C-625-CCS1-CHD
	Express 250 Station includes 2x Power Modules, 1x CCS2 cable, 1x CHAdeMO cable (EU)	CPE250C-625-CCS2-CHD
Option	Other cable combinations are available using CCS1, CCS2 and CHAdeMO connectors	Please contact ChargePoint sales

Software & Services

Description	Order Code
ChargePoint Cloud Plan	Please contact ChargePoint sales
ChargePoint Assure — Prepaid Assure Plan for one Power Module. Express 250 requires 2x EXPRESS-ASSURE n to cover the two Power Modules and the CPE250 station.	EXPRESS-ASSURE n ¹
ChargePoint Assure — Assure Plan for one Power Module and invoiced annually. Express 250 requires 2x EXPRESS-ASSURE n to cover the two Power Modules and the CPE250 station	EXPRESS-ASSUREN-COMMIT ¹
Station Activation and Configuration	CPSUPPORT-ACTIVE
ChargePoint Station Installation and Validation	CPE250-INSTALLVALID

Note: All CPE250 stations require a cloud plan.

*Substitute n for desired years of service (1, 2, 3, 4 or 5 years).

Order Code Information

If ordering this...	...the order code is
Express 250 Station includes 2x Power Modules, 1x CCS1 cable, 1x CHAdeMO cable (NA)	CPE250C-CCS1-CHD
3 years of prepaid Assure coverage upon successful site validation. Assure covers Power Modules & station. Express 250 requires 2x EXPRESS-ASSURE3 for its 2 Power Modules.	2 x EXPRESS-ASSURE3
Station Activation and Configuration	CPSUPPORT-ACTIVE

Architectural Drawings (Dimensions)

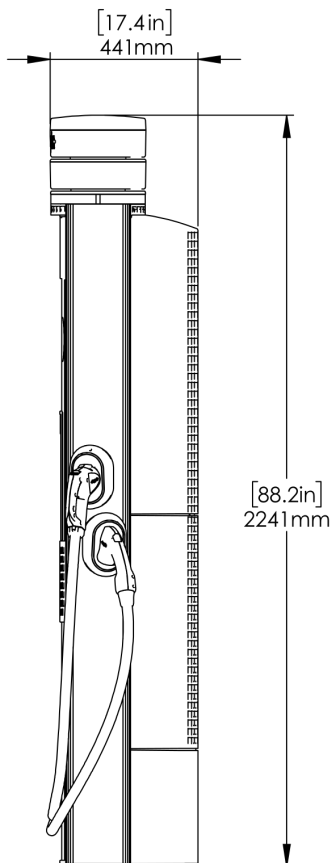
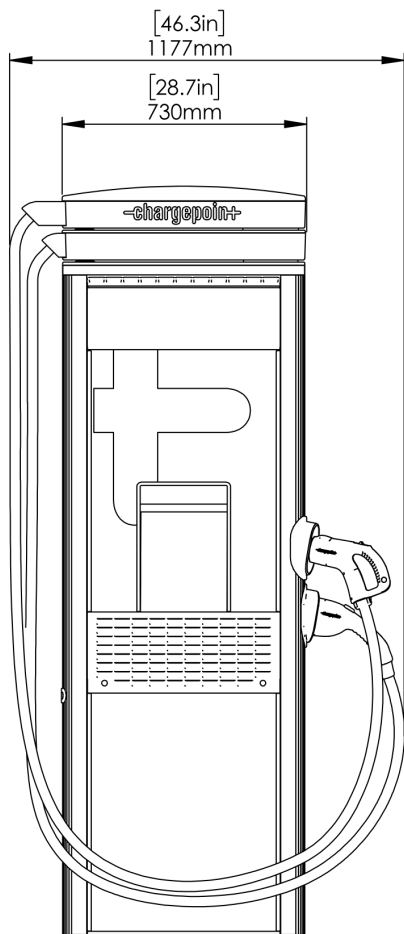
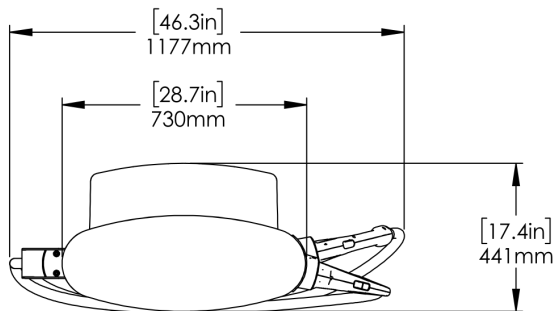

General Specifications

Station Electrical Input

Input Rating	400V AC, 3-phase, 96A, 50 Hz 480V AC, 3-phase, 80A, 60 Hz
Wiring	L1, L2, L3, Neutral & Earth

Station Electrical Output

Max Output Power	62.5 kW
Output Voltage, Charging	200–1,000V DC
Max Output Current	156A
Max Modules per Station	2

Paired Station Electrical Output

Paired Max Output Power	125 kW
Paired Max Output Current	CCS1: 174A or 200A CCS2: 200A CHAdeMO; US: 140A, EU: 125A

Power Module

Max Output Power	31.25 kW
Max Output Current	78 A
Power Conversion Efficiency	> 95%
Power Factor	0.99 at full load
Harmonics	iTHD < 5% (Complies with IEEE 519 Requirements)
Power Module Cooling	Liquid Cooling Technology

Functional Interfaces

Max Connector Types per Station	Up to two different connector types per station
Supported Connector Types	CHAdeMO, CCS1 (SAE J1772™ Combo), CCS2 (IEC 61851-23)
Cable Length with Swing Arm*	Full Horizontal Reach: 4.27m (14')
LCD Display	Full-color 254 mm (10 in) display for driver interaction
Top Display	Full-color 508 mm (20 in) LED display for notifications
Authentication	RFID: ISO 15693, ISO 14443, NEMA EVSE 1.2-2015 (UR) Tap to Charge (NFC on Apple & Android): 15118-1 (EIM) Remote: Mobile and in vehicle (if supported by vehicle)

*Horizontal reach to typical vehicle charging port: 3.76 (12'4")

Connectivity Features

Vehicle Safety Communication	CHAdeMO – JEVS G104 over CAN, CCS1 – SAE J1772 over PLC and CCS2 — IEC 61851-23
Plug-Out Detection	Power terminated per JEVS G104 (CHAdeMO), SAE J2931 (CCS1) and IEC 61851-23 (CCS2)
Local Area Network	2.4 GHz and 5 GHz WiFi (802.11 b/g/n)
Wide Area Network	4G LTE (fall back to 3G GSM)
Supported Communication Protocols	OCPP
Service and Maintenance	Remote system monitoring, diagnostic, and proactive maintenance

Safety and Operational Ratings

Station Enclosure Rating	Type 3R, IP54
Station Impact Rating	IK10
Safety and Compliance	UL and cUL listed: complies with UL 2202, UL 2231-1, UL 2231-2, CSA 107.1 CE marking: complies with IEC 62196, IEC 61851
Station Surge Protection	Tested to IEC 6100-4-5, Level 5 (6 kV @ 3,000A). In geographic areas subject to frequent thunder storms, supplemental surge protection at the service panel is recommended.
EMC Compliance	U.S.: FCC part 15 Class A; EU: EN55011, EN55022 and IEC61000-4
Cooling	Liquid Cooling Technology

ChargePoint Express 250 Datasheet

Storage Temperature	-40°C to 50°C (-40°F to 122°F)
Operating Temperature	-30°C to 50°C (-22°F to 122°F)
Operational Altitude	<3,000 m (<9,800 ft)
Operating Humidity	Up to 95% @ 50°C (122°F) non-condensing

Generic Specifications

Station Enclosure Dimensions	2,230 mm x 712 mm x 420 mm (7'4" x 2'4" x 1'4")
Power Module Dimensions	760 mm x 430 mm x 130 mm (2'6" x 1'5" x 5")
Station Weight (without Power Modules)	250 kg (551 lb)
Power Module Weight	45 kg (98.5 lb)

Energy Management Features

Dynamic Power Management	Allows a fixed maximum power output per station or lets the system dynamically manage the power distribution per station
Remote Energy Management	Manage output power via the ChargePoint Admin Portal, API, and Open ADR 2.0b VEN

ChargePoint, Inc. reserves the right to alter product offerings and specifications at any time without notice, and is not responsible for typographical or graphical errors that may appear in this document



ChargePoint, Inc.
 240 East Hacienda Avenue
 Campbell, CA 95008-6617 USA
 +1.408.841.4500 or
 +1.877.370.3802 US and Canada toll-free
 chargepoint.com

Contact Us
 Visit chargepoint.com
 Call +1.408.705.1992
 Email sales@chargepoint.com

Copyright © 2019 ChargePoint, Inc. All rights reserved. CHARGEPOINT is a U.S. registered trademark/service mark, and an EU registered logo mark of ChargePoint, Inc. All other products or services mentioned are the trademarks, service marks, registered trademarks or registered service marks of their respective owners. October 2019.

* Listed by Underwriters Laboratories Inc.



Supplemental Specifications **Revised 2/4/2020**

1.01 **TECHNICAL SPECIFICATIONS:**

The Technical Specifications and Drawings are provided under separate cover at the Purchasing Department website at <https://www.cantonohio.gov/448/Purchasing-Procurement>.

All item numbers referenced to in the drawings refer to the State of Ohio Department of Transportation Construction and Material Specifications, 2019 Edition. All equipment, material and workmanship shall be performed according to these specifications and any Ohio Department of Transportation Standard Construction Drawings (SCD) referenced on the plans.

1.02 **SUPPLEMENTAL SPECIFICATIONS:**

01-00 - Project Documentation and Submittal Requirements for All Public Work Projects and Subdivision Developments

Supplemental Specification 01-00

PROJECT DOCUMENTATION AND SUBMITTAL REQUIREMENTS FOR ALL PUBLIC WORK PROJECTS AND SUBDIVISION DEVELOPMENTS

September, 2000

*Revised August, 2018

Project Submittals: The following listed items are the full responsibility of the Contractor. These items become part of the administrative duties imposed upon this Contract. The Contractor shall be responsible for submitting all detail items prior to the contract Notice of Commencement, or as directed by the City's Project Manager. A typewritten letter shall accompany all items, on Company letterhead; clearly describe each item submitted. If Contractor elects to fax any documentation due to expediency, the Contractor will be responsible for submitting hard copy for project documentation. The City will reject any information not clearly legible. **Submit four copies of the project submittals.**

Contractor will clearly affix a label or stamp identifying the submittal and its status for project review. All actions other than "no exception taken" will require supporting notation or information for project review.

Allow at least 10 business days for City's review and execution. The City Project Manager shall assist the Contractor with any questions or clarification during this process to ensure timely response to the Contractor.

The City will not pay directly for the performance of the work listed. This work is a subsidiary obligation of the Contractor.

1. Shop Drawings
2. Preconstruction Video
3. Progress Schedule
4. Release Statement for Disposal of Excavated Material
5. Traffic Control Plan
6. Contractor and Subcontractor Emergency Contact List
7. Statements of Final Compliance

1. Shop Drawings

- a) Upon written request from the Engineer, the Contractor shall submit detailed drawings, acceptable catalog data, specification and material certifications for all materials and/or equipment specialized or required for the proper completion of the work.
- b) Contractor shall submit shop drawings in not less than four (4) copies to the Engineer.
- c) Contractor shall submit shop drawings in proper sequence of construction to cause no delay in the work. The Engineer will have ten (10) business days to review submittals. The Contractor's failure to transmit appropriate submittals to the Engineer sufficiently in advance of work shall not be grounds for time extension. No work shall be performed

requiring shop drawings until same the Engineer has approved these shop drawings.

- d) Label each shop drawing with the following:
 1. Project Name
 2. Name of Contractor
 3. Name of Subcontractor (if applicable)
 4. Name and Address of Supplier and/or Manufacturer
 5. Log Reference Number
 - e) The Contractor is responsible for reviewing and approving all shop drawings prior to submittal. The Engineer's review does not make him responsible for the accuracy of said drawings.
2. **Preconstruction Video:** Prior to actual construction, the Contractor shall take video recording of the entire length and width of the work site.
- a) The Contractor shall notify the Engineering Department prior to scheduling the video recording of the site. A representative of the Engineering Department shall be present when the recording this video.
 - b) The video and audio recordings shall be on DVD or pre-approved alternative for replay. Contractor must submit alternative medium to the Engineer and approval received prior to scheduling.
 - c) The video portion shall have continuous time and date incorporated into it, locations and person(s) doing the work.
 - d) Audio comments during the recording must address each item in the field of view as it may pertain to the project construction. The recording technician will need to become familiar with the project plans to know what subject matter is pertinent. Further, contractor must incorporate a post recording review and audio comments into the recording.
 - e) Submitted copies of all recordings are the property of the Engineer. Contractor must submit the recording and be accepted in full by the Engineering Department prior to the start of construction.
3. **Progress Schedule:** The Contractor shall provide to the City, as mutually agreed upon at the Contract's Preconstruction meeting, a graphic progress schedule, which shall include the following:
- a) Progress schedule as a minimum to be prepared in **CRITICAL PATH METHOD FORMAT (CPM)**. The schedule shall be submitted, as a minimum, on 11" x 17" format for clarity and any necessary notations. Progress schedule shall include all work activities relative to the project, as further described in the Contract. Activities and rate of expected progress to secure completion as set forth in the Contract shall be shown on the schedule. Contractor to annotate any milestones that may be indicated in the Contract. Project completion date shall be clearly defined on the original schedule and all ensuing schedules provided.
 - b) Schedules shall be updated, as a minimum, every 30 days, or as agreed to by the City's Project Manager.

4. Release Statement for Disposal of Excavated Materials

- (a) The Contractor shall provide to the City a written consent statement from all property owners whose property is a landfill depository for all surplus or unsuitable excavated material from the project site.
- (b) The Contractor shall follow ODOT 105.16 for specific guidelines and name the “City of Canton” in lieu of “the Department” on all forwarded documents. The City requires a contract or permit that contains the language stating that the City is not party to the contract or permit, the material is not the City’s, and that the contractor and the property owner will hold the City harmless from claims that may arise from this contract or permit.
- (c) See attached sample copy for referencing purposes.

5. Traffic Control Plan: Contractor shall submit a graphical presentation or written document detailing the signage to be used and its location for maintenance of traffic. If traffic control will be performed in stages, submit a plan for each stage. Any proposed detours should be approved by the Engineer prior to plan submission.

6. Contractor and Subcontractor Emergency Contact List: Contractor shall submit to the Engineer, prior to commencing construction, a complete list of the Contractor’s personnel associated with the project. List should include name, title, and emergency contact phone numbers for each individual.

7. Statements of Final Compliance: The Contractor shall submit to the City the following documentation, in addition to the Project’s General Conditions. All submittals shall be completed and approved prior to the release of the final retainer.

- a) Certificates of Substantial and Final Completion. Contractor shall submit in writing, the date on which work is substantially completed and upon Final Completion. Any deviation from the stated contract completion date to what is being submitted shall be explained further by the Contractor. The City, at their discretion, will further review this subject, as needed.
- b) Final Waiver of Lien
Contractor shall furnish a written report indicating the resolution of any and all property damage claims filed with Contractor by any party during the contract period. The information shall include the name of claimant; date filed with Contractor; name of Insurance Company and/or Adjustor handling the claim; how the claim was resolved; if claim was not resolved for the full amount, a statement indicating the reason for such action. If there were no damage claims filed with the Contractor, then this shall be so stated in the report.

(SAMPLE COPY)
Waste Disposal Agreement for Projects in the City of Canton

Items 1, 3 - 9 are optional and discretionary to the undersigned

THIS WASTE AGREEMENT, made this _____ day of _____ 20___, by and between _____ (called "Contractor"), and _____ of _____ (called "Land Owner"), concerning a certain construction contract between the Contractor and _____ in the City of Canton, OH for the _____ (project), as follows:

1. **MANNER OF WASTING:** Land Owner grants to Contractor the exclusive right to place dirt, earth, rock, topsoil, subsurface, unsuitable and/or other excess material (called "waste material") upon the area described in the following paragraph without requirement, limit, or restriction as to depth, amount, manner, or time.
2. **WASTE AREA:** The property upon which Contractor is permitted to place material is commonly known as _____ (address).
3. **TITLE TO WASTE AREA:** The Land Owner warrants that it has title to and the right to contract for placement of waste material in said area and agrees to defend and indemnify Contractor against any claim, suit, or damage arising out of such title or right to contract.
4. **ACCESS AND USE:** Land Owner hereby grants Contractor the right of ingress and egress to the waste area in locations to be selected by Contractor for all purposes necessary to the complete fulfillment of this agreement, and the right of quiet enjoyment in the intended use of such area.
5. **PAYMENT:** Contractor agrees to pay and Land Owner agrees to accept as full and final compensation for all rights granted and covenants contained herein and all claims of every nature the sum of _____ payable _____.
6. **BASIS OF MEASUREMENTS:** It is mutually agreed that measurement of the amount of materials wasted, where required, shall be made on the following basis: _____ and said measurement shall be binding upon the parties hereto for all purposes.
7. **DAMAGES:** Land Owner hereby waives any and all claims for damage to the waste area and to the area of ingress and egress except as specifically noted herein.
8. **RELEASE:** Upon receipt of final payment hereunder, and provided all terms of this agreement have been fulfilled, Land Owner hereby releases Contractor from further liability of any kind or nature hereunder.

WITNESSES:

CONTRACTOR:

Authorized Signature & Title

LANDOWNER:

Signature

9. **ENTIRE AGREEMENT:** It is agreed that the terms and conditions of this agreement are fully covered in the foregoing, and that any oral or written statements made by either party, or agents claiming to represent either party, not set forth herein, are not binding on the parties and are not considered as part of this Agreement.
10. **DISCLAIMER:** The City of Canton is not a party to the here above agreement. The Contractor and Landowner shall indemnify and save harmless the City of Canton from any claim that may arise from the here above agreement. The waste material is the property of the Contractor, not the City of Canton.