

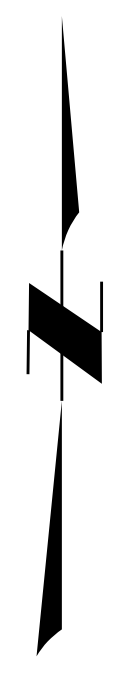

STATE	COUNTY	ROUTE NO.	SHEET NO.
SC	BERKELEY	S-131 & S-275	1

PROPOSED PLANS TOWN OF SUMMERVILLE BEAR ISLAND ROAD TRAFFIC SIGNALS PROJECT BERKELEY COUNTY



INDEX OF SHEETS

SHEET NO	DESCRIPTION	SHEET SUB-TOTALS
1	TITLE PAGE	1
Q1	SUMMARY OF ESTIMATED QUANTITIES	1
TS1	N. MAPLE STREET (S-131) AT BEAR ISLAND ROAD TEMPORARY TRAFFIC SIGNAL	1
TS2	N. MAPLE STREET (S-131) AT BEAR ISLAND ROAD TRAFFIC SIGNAL	1
TS3	BEAR ISLAND ROAD/AZALEA SQUARE BOULEVARD AT SHEEP ISLAND ROAD (S-275) TEMPORARY TRAFFIC SIGNAL	1
TS4	BEAR ISLAND ROAD/AZALEA SQUARE BOULEVARD AT SHEEP ISLAND ROAD (S-275) TRAFFIC SIGNAL	1
TOTAL		6

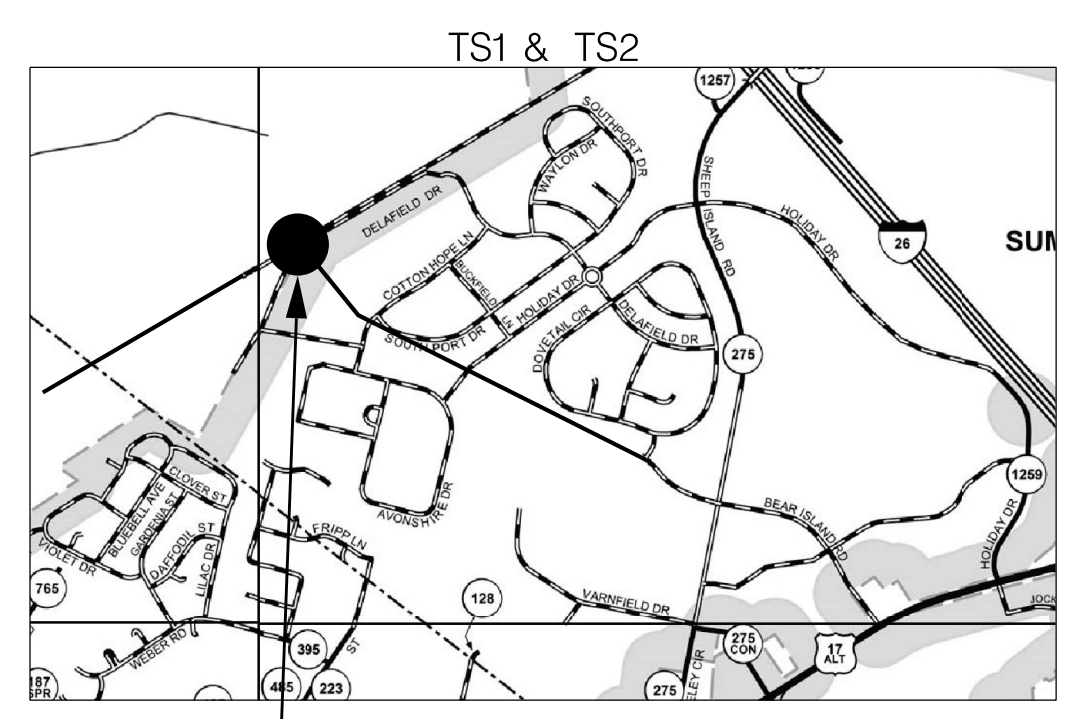

N. MAPLE STREET (S-131) AT BEAR ISLAND ROAD

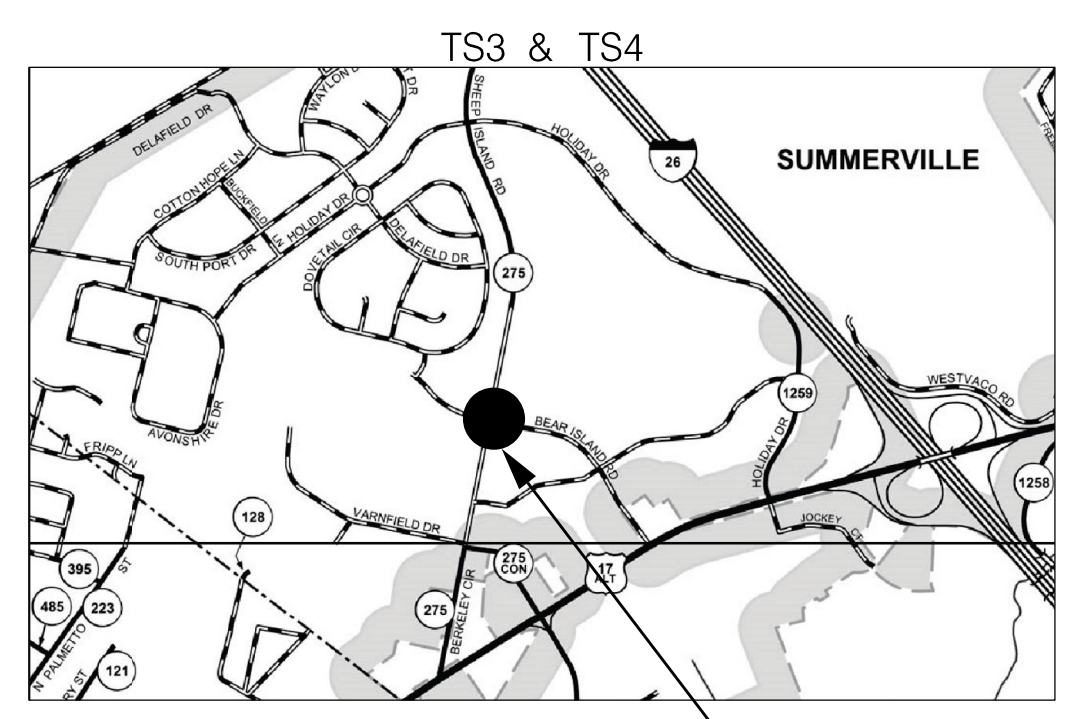

BEAR ISLAND ROAD/AZALEA SQUARE BOULEVARD AT SHEEP ISLAND ROAD (S-275)

\$\$\$\$\$path\$\$\$\$\$filename\$\$\$\$\$

RAILROAD INVOLVEMENT? YES <input type="radio"/> NO <input checked="" type="radio"/>
--

3 DAYS BEFORE DIGGING IN SOUTH CAROLINA CALL 811 SOUTH CAROLINA 811 (SC811) WWW.SC811.COM ALL UTILITIES MAY NOT BE A MEMBER OF SC811
--

CONSULTING ENGINEERING FIRM

RKA

RAMEY KEMP ASSOCIATES

7301 Rivers Avenue
Suite 242
North Charleston, SC 29406

Phone: 843-614-3800
www.rameykemp.com

ENGINEER OF RECORD

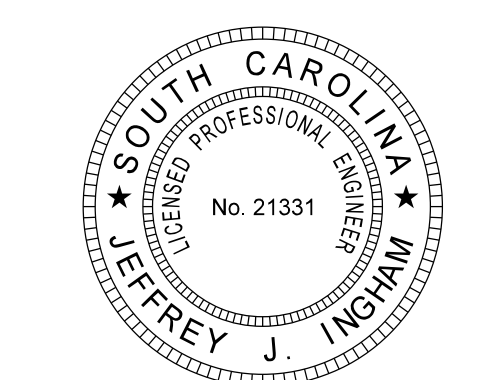

DocuSigned by:
Jeffrey J. Ingram
703656ABCA3A63

FOR CONSTRUCTION : _____ DATE 6/3/2020

SUMMARY OF ESTIMATED QUANTITIES

STATE	COUNTY	ROUTE NO.	SHEET NO.
S.C.	BERKELEY	S-131 & S-275	Q 1

N. MAPLE STREET (S-131) AT BEAR ISLAND ROAD

Temporary Traffic Signal Quantities

ITEM NO.	PAY ITEM	QUANTITY	PAY UNIT
1031000	MOBILIZATION	1	LS
1071000	TRAFFIC CONTROL	1	LS
2027005	REMOVAL & DISPOSAL OF CONCRETE MEDIAN BARRIER	80	LF
6271010	4" WHITE SOLID LINES (PVT. EDGE LINES) THERMO.- 90 MIL.	90	LF
6271015	8" WHITE SOLID LINES THERMOPLASTIC - 125 MIL.	315	LF
6271025	24" WHITE SOLID LINES (STOP/DIAG LINES)-THERMO.-125 MIL	70	LF
6319505	REMOVAL OF PAVEMENT MARKINGS	80	LF
6510108	FLAT SHEET, TYPE VIII OR IX, SIZE DETERMINED BY MSG. - OVERHEAD	20	SF
6513015	MOUNTING ASSEMBLY FOR F.S. SIGN ERCTD ON SPAN WIRE	1	EA
6531210	U-SECTION POST FOR SIGN SUPPORTS - 3P	3	LF
6750275	FURNISH & INSTALL 1.0" SCHEDULE 80 PVC CONDUIT	70	LF
6750278	FURNISH & INSTALL 2.0" SCHEDULE 80 PVC CONDUIT	835	LF
675027C	FURNISH & INSTALL 3.0" SCHEDULE 80 PVC CONDUIT	5	LF
6770388	FURNISH & INSTALL NO. 14 COPPER WIRE, 4 CONDUCTOR - BLACK	1412	LF
6770389	FURNISH & INSTALL NO. 14 COPPER WIRE, 4 CONDUCTOR - GRAY	2410	LF
6770393	FURNISH & INSTALL NO. 14 COPPER WIRE, 8 CONDUCTOR (BLACK)	1622	LF
6770394	FURNISH & INSTALL NO. 14 COPPER WIRE, 8 CONDUCTOR (GRAY)	788	LF
6770413	FURNISH & INSTL NO. 14 COPPER WIRE,1-CONDUCTOR FOR LOOP WIRE	1130	LF
6780495	SAWCUT FOR LOOP DETECTOR	570	LF
6800499	FURNISH & INSTALL ELECTRICAL SERVICE FOR TRAFFIC SIGNAL	1	EA
6800508	F&I-12"X12"X12"D.ELEC.FLUSH UNDGRD.ENCLÓS-(STR.POLY.CONC.)JD	2	EA
6800518	F&I-13"X24"X18"D.ELEC.FLUSH UNDGRD.ENCLÓS-(STR.POLY.CONC.)JD	13	EA
6800528	17"X30"X18"D.ELEC.FLUSH UNDGRD.ENCLÓSURE-(STR.POLY.CONC.)JD	1	EA
6825020	FURNISH & INSTALL - 35' WOOD POLE-CLASS II-CCA TR(0.60)	4	EA
6825092	FURNISH & INSTALL 3/8" GALVANIZED STEEL CABLE	400	LF
6825484	FURNISH & INSTALL 10' BREAK-AWAY ALUM PEDESTAL POLE AND BASE	4	EA
6845511	F&I - CONTR 332/336 CABINET ASSEMBLY - BASE MOUNTED	1	EA
6865720	FURNISH & INSTALL -12" 4 SECTION SIGNAL HEAD	1	EA
6865723	FURNISH & INSTALL - 12" 3 SECTION SIGNAL HEAD	7	EA
6865782	FURNISH & INSTALL PEDESTRIAN SIGNAL HEAD	6	EA
6865797	F&I-PED PUSH BUT.SOLID STATE W/ LIGHT&TONE ASSEM 9"X15"&SIGN (R-10-3E or R10-4a)	6	EA
6865834	FURNISH & INSTALL BACKPLATE W/ RETROREFL.BORDERS FOR TRAFFIC SIGNAL	8	EA
6888177	DESIGN, FURNISH & INSTALL STEEL POLE WITH TWIN MAST ARMS INCLUDING FOUNDATION	0	EA
7209000	PEDESTRIAN RAMP CONSTRUCTION	67	SY

Traffic Signal Quantities

ITEM NO.	PAY ITEM	QUANTITY	PAY UNIT
1031000	MOBILIZATION	1	LS
1071000	TRAFFIC CONTROL	1	LS
6510108	FLAT SHEET, TYPE VIII OR IX, SIZE DETERMINED BY MSG. - OVERHEAD	2.5	SF
6513020	F&I MOUNTING ASSEMBLY FOR F.S. SIGN ERCTD ON MAST ARM	1	EA
6750278	FURNISH & INSTALL 2.0" SCHEDULE 80 PVC CONDUIT	300	LF
6760065	FURNISH & INSTALL 2" SCHEDULE 80 HDPE CONDUIT (DIRECTIONAL BORED)	250	LF
6770388	FURNISH & INSTALL NO. 14 COPPER WIRE, 4 CONDUCTOR - BLACK	893	LF
6770389	FURNISH & INSTALL NO. 14 COPPER WIRE, 4 CONDUCTOR - GRAY	866	LF
6770393	FURNISH & INSTALL NO. 14 COPPER WIRE, 8 CONDUCTOR (BLACK)	1281	LF
6770394	FURNISH & INSTALL NO. 14 COPPER WIRE, 8 CONDUCTOR (GRAY)	467	LF
6800500	MOD. EXIST ELECTRICAL SERVICE FOR TRAFFIC SIGNAL	1	EA
6800518	F&I-13"X24"X18"D.ELEC.FLUSH UNDGRD.ENCLÓS-(STR.POLY.CONC.)JD	6	EA
6865720	FURNISH & INSTALL -12" 4 SECTION SIGNAL HEAD	1	EA
6865723	FURNISH & INSTALL - 12" 3 SECTION SIGNAL HEAD	6	EA
6865834	FURNISH & INSTALL BACKPLATE W/ RETROREFL.BORDERS FOR TRAFFIC SIGNAL	7	EA
6888177	DESIGN, FURNISH & INSTALL STEEL POLE WITH TWIN MAST ARMS INCLUDING FOUNDATION	2	EA

BEAR ISLAND ROAD/AZALEA SQUARE BOULEVARD AT OLD LIGHT ROAD (S-275)

Temporary Traffic Signal Quantities

ITEM NO.	PAY ITEM	QUANTITY	PAY UNIT
1031000	MOBILIZATION	1	LS
1071000	TRAFFIC CONTROL	1	LS
6510108	FLAT SHEET, TYPE VIII OR IX, SIZE DETERMINED BY MSG. - OVERHEAD	20	SF
6513015	MOUNTING ASSEMBLY FOR F.S. SIGN ERCTD ON SPAN WIRE	2	EA
6531210	U-SECTION POST FOR SIGN SUPPORTS - 3P	3	LF
6750275	FURNISH & INSTALL 1.0" SCHEDULE 80 PVC CONDUIT	50	LF
6750278	FURNISH & INSTALL 2.0" SCHEDULE 80 PVC CONDUIT	325	LF
675027C	FURNISH & INSTALL 3.0" SCHEDULE 80 PVC CONDUIT	5	LF
6770388	FURNISH & INSTALL NO. 14 COPPER WIRE, 4 CONDUCTOR - BLACK	1538	LF
6770389	FURNISH & INSTALL NO. 14 COPPER WIRE, 4 CONDUCTOR - GRAY	1628	LF
6770393	FURNISH & INSTALL NO. 14 COPPER WIRE, 8 CONDUCTOR (BLACK)	1176	LF
6770394	FURNISH & INSTALL NO. 14 COPPER WIRE, 8 CONDUCTOR (GRAY)	903	LF
6770413	FURNISH & INSTL NO. 14 COPPER WIRE,1-CONDUCTOR FOR LOOP WIRE	1470	LF
6780495	SAWCUT FOR LOOP DETECTOR	700	LF
6800499	FURNISH & INSTALL ELECTRICAL SERVICE FOR TRAFFIC SIGNAL	1	EA
6800508	F&I-12"X12"X12"D.ELEC.FLUSH UNDGRD.ENCLÓS-(STR.POLY.CONC.)JD	2	EA
6800518	F&I-13"X24"X18"D.ELEC.FLUSH UNDGRD.ENCLÓS-(STR.POLY.CONC.)JD	13	EA
6800528	17"X30"X18"D.ELEC.FLUSH UNDGRD.ENCLÓSURE-(STR.POLY.CONC.)JD	1	EA
6825020	FURNISH & INSTALL - 35' WOOD POLE-CLASS II-CCA TR(0.60)	4	EA
6825092	FURNISH & INSTALL 3/8" GALVANIZED STEEL CABLE	410	LF
6825484	FURNISH & INSTALL 10' BREAK-AWAY ALUM PEDESTAL POLE AND BASE	4	EA
6845511	F&I - CONTR 332/336 CABINET ASSEMBLY - BASE MOUNTED	1	EA
6865720	FURNISH & INSTALL -12" 4 SECTION SIGNAL HEAD	2	EA
6865723	FURNISH & INSTALL - 12" 3 SECTION SIGNAL HEAD	8	EA
6865782	FURNISH & INSTALL PEDESTRIAN SIGNAL HEAD	8	EA
6865797	F&I-PED PUSH BUT.SOLID STATE W/ LIGHT&TONE ASSEM 9"X15"&SIGN (R-10-3E or R10-4a)	8	EA
6865834	FURNISH & INSTALL BACKPLATE W/ RETROREFL.BORDERS FOR TRAFFIC SIGNAL	10	EA

Traffic Signal Quantities

ITEM NO.	PAY ITEM	QUANTITY	PAY UNIT
1031000	MOBILIZATION	1	LS
1071000	TRAFFIC CONTROL	1	LS
6510108	FLAT SHEET, TYPE VIII OR IX, SIZE DETERMINED BY MSG. - OVERHEAD	5	SF
6513020	F&I MOUNTING ASSEMBLY FOR F.S. SIGN ERCTD ON MAST ARM	2	EA
6531210	U-SECTION POST FOR SIGN SUPPORTS - 3P	0	LF
6750278	FURNISH & INSTALL 2.0" SCHEDULE 80 PVC CONDUIT	10	LF
6760065	FURNISH & INSTALL 2" SCHEDULE 80 HDPE CONDUIT (DIRECTIONAL BORED)	275	LF
6770388	FURNISH & INSTALL NO. 14 COPPER WIRE, 4 CONDUCTOR - BLACK	1055	LF
6770389	FURNISH & INSTALL NO. 14 COPPER WIRE, 4 CONDUCTOR - GRAY	662	LF
6770393	FURNISH & INSTALL NO. 14 COPPER WIRE, 8 CONDUCTOR (BLACK)	1423	LF
6770394	FURNISH & INSTALL NO. 14 COPPER WIRE, 8 CONDUCTOR (GRAY)	562	LF
6800500	MOD. EXIST ELECTRICAL SERVICE FOR TRAFFIC SIGNAL	1	EA
6800518	F&I-13"X24"X18"D.ELEC.FLUSH UNDGRD.ENCLÓS-(STR.POLY.CONC.)JD	2	EA
6865720	FURNISH & INSTALL -12" 4 SECTION SIGNAL HEAD	2	EA
6865723	FURNISH & INSTALL - 12" 3 SECTION SIGNAL HEAD	8	EA
6865834	FURNISH & INSTALL BACKPLATE W/ RETROREFL.BORDERS FOR TRAFFIC SIGNAL	10	EA
6888177	DESIGN, FURNISH & INSTALL STEEL POLE WITH TWIN MAST ARMS INCLUDING FOUNDATION	2	EA

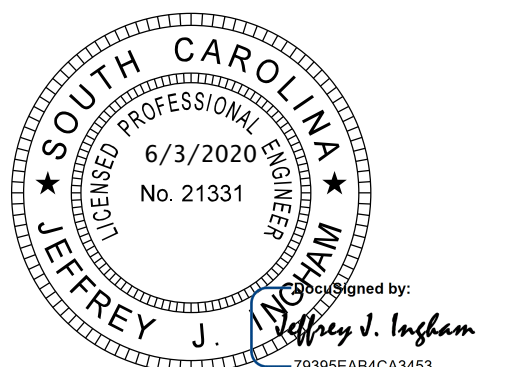

SIGNAL EQUIPMENT

ONE (1) NEW 8-PHASE FULLY ACTUATED STANDARD 2070 CONTROLLER WITH FLASHER, SIGNAL MONITOR UNIT, AND BASE-MOUNTED 332A CABINET.
4 ORACLE, (2)-CHANNEL VEHICLE DETECTOR UNITS

CABINET: EXT. PROP.
VEHICLE SIGNALS: EXT. PROP.

PEDESTRIAN SIGNALS: EXT. PROP.

HEAD NUMBER	1,2F	2	6	8	2P	8P
LENS		R	R	R		
PHASE	1,OLA	2	6	8	2P	8P
SIZE	12"	12"	12"	12"	16"	16"
QUANTITY	1	3	2	2	2	4

OLA:Ø1 + Ø2 (FYA) OLC:
OLB: OLD:

- METAL POLES W/O MAST ARMS: EXT. PROP.
- METAL POLES W/ MAST ARMS: EXT. PROP.
- WOOD POLES AS NECESSARY: EXT. PROP.
- SPLICE BOXES AS NECESSARY: EXT. PROP.
- INDUCTANCE LOOPS AS NECESSARY: EXT. PROP.
- GUYS AS NECESSARY: EXT. PROP.
- WIRELESS DETECTORS AS NECESSARY: EXT. PROP.

TABLE OF OPERATION	PHASE IN OPERATION			
	Ø1 + Ø6	Ø2 + Ø6	Ø8	FLASH
1,2F				
2	R	G	R	Y
6	G	G	R	Y
8	R	R	G	R
2P	DW	W	DW	DRK
8P	DW	DW	W	DRK

SIGNAL TIMINGS

	PHASE							
	1	2	3	4	5	6	7	8
WALK	-	7	-	-	-	-	-	7
DON'T WALK	-	40	-	-	-	-	-	25
MIN INITIAL	6	15	-	-	-	15	-	8
MAX INITIAL	-	37	-	-	-	37	-	-
ADD/VEH	-	1.6	-	-	-	1.6	-	-
VEH EXT	2.5	6.0	-	-	-	6.0	-	3.0
TIM BFR REDUC	-	25	-	-	-	25	-	-
TIME TO REDUC	-	20	-	-	-	20	-	-
MIN GAP	-	2.5	-	-	-	2.5	-	-
MAX LIMIT	15	60	-	-	-	60	-	35
MAXIMUM 2	-	-	-	-	-	-	-	-
YELLOW	3.0	4.5	-	-	-	4.5	-	3.0
RED CLEAR	3.9	2.4	-	-	-	2.4	-	3.0

LOOP DETECTOR INSTALLATION CHART

PHASE/ LOOP LTR#	DETECTOR	AMP NO.	CHAN NO.	WIRED TO PHASE(S)	X LOCK	X NON-LOCK	X PULSE	X PRES	OPERATION		SPECIAL FEATURES	LOOP DESIGN		
									DELAY SEC	EXT SEC		TIME OF DAY-TOD, SWITCHING, etc.	SIZE	NO.OF TURNS
1A	1	-	-	1	-	X	-	X	-	-	QUADRUPOLE	6' X 30'	2-4-2	-3'
2A	2	-	-	2	X	-	-	X	-	-	-	6' X 6'	6	330'
2B	2	-	-	2	X	-	-	X	-	-	-	6' X 6'	6	330'
6A	3	-	-	6	X	-	-	X	-	-	-	6' X 6'	6	330'
6B	3	-	-	6	X	-	-	X	-	-	-	6' X 6'	6	330'
8A	4	-	-	8	-	X	-	X	-	-	QUADRUPOLE	6' X 30'	2-4-2	-3'
8B	4	-	-	8	-	X	-	X	-	-	QUADRUPOLE	6' X 30'	2-4-2	-3'

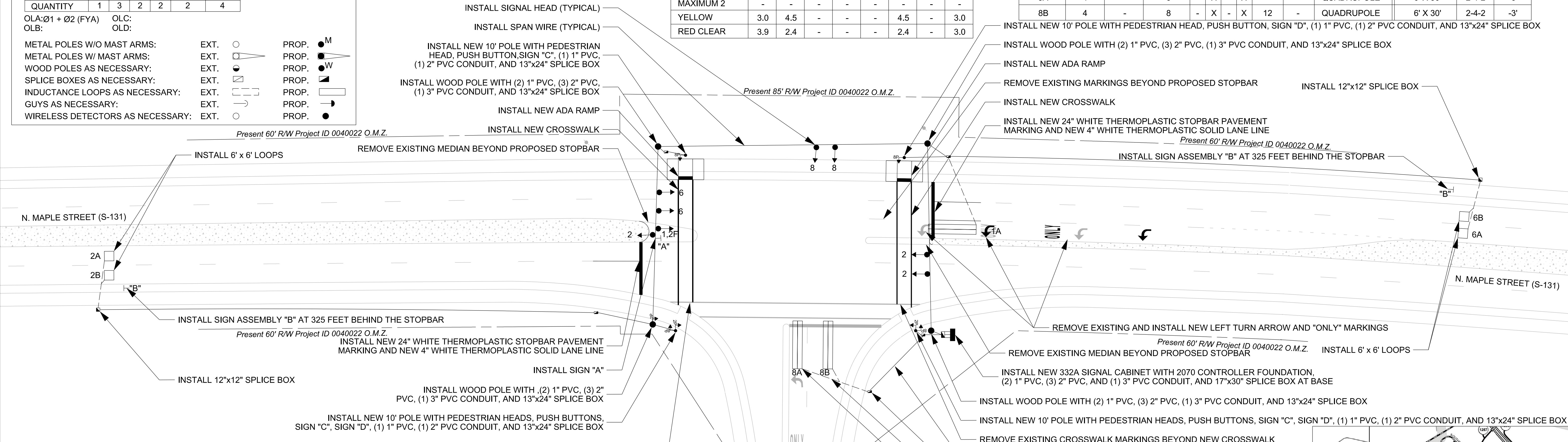

NEMA PHASING

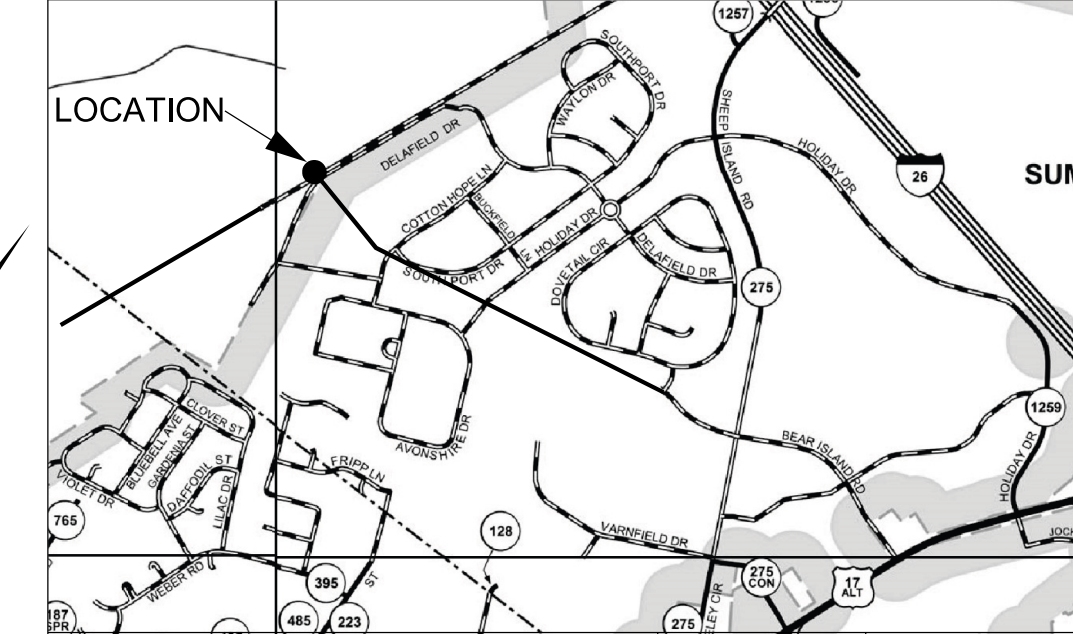
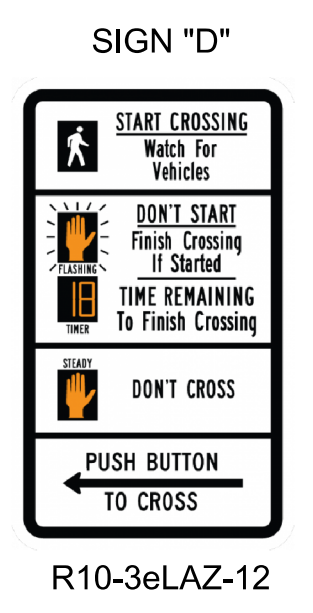
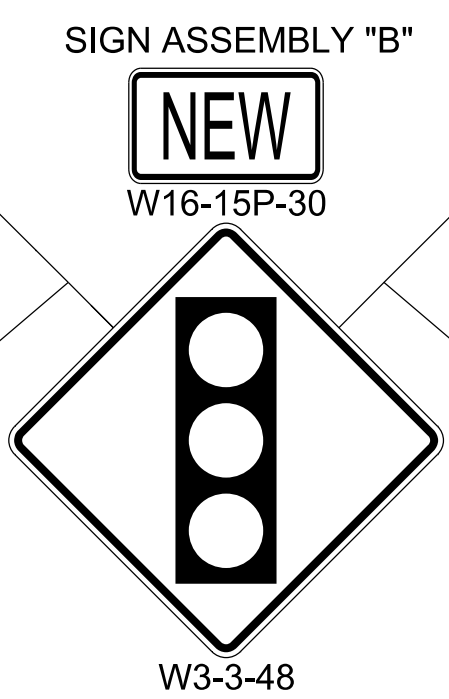
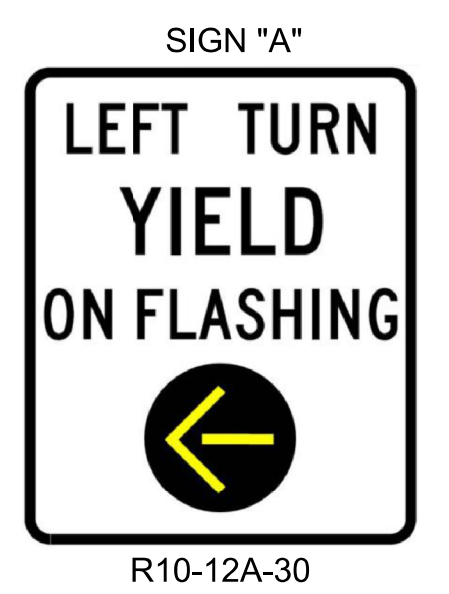
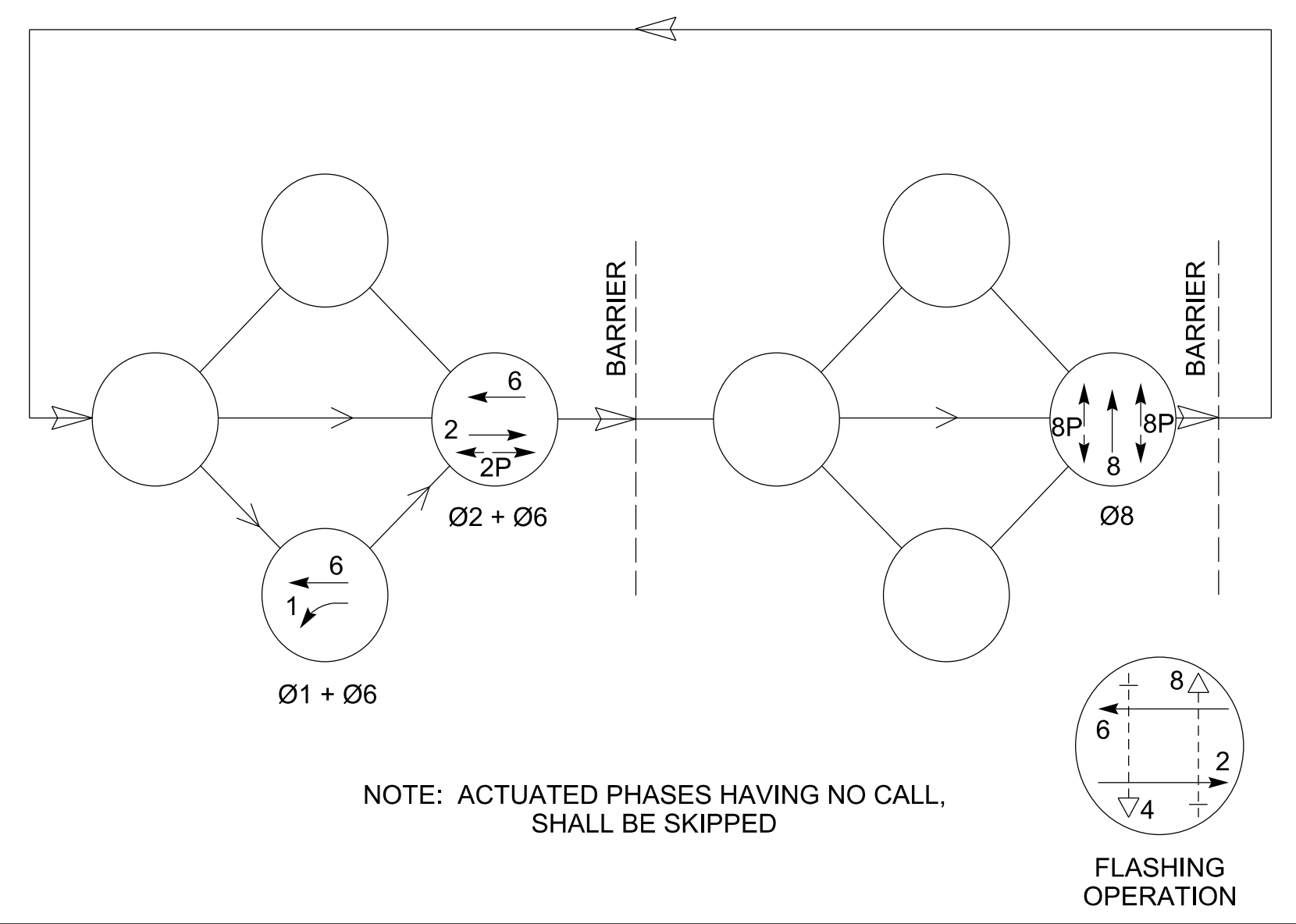

ROUTE NUMBER	S-131	BEAR ISLAND ROAD
APPROACH DIRECTION	EB WB NB SB	
SIGNAL DESIGN SPEED (MPH)	45 45 25 -	
GRADE (%)	0.32%-0.32% 0%	

* ESTIMATED FROM PROJECT ID 0040022



Prepared By:
RKA
RAMEY KEMP ASSOCIATES
7301 Rivers Avenue
Suite 242
North Charleston, SC 29406
Phone: 843-614-3800
www.rameykemp.com

TEMPORARY TRAFFIC SIGNAL PLAN			
N. MAPLE STREET (S-131) at BEAR ISLAND ROAD			
District 6	Berkeley County	Summerville, SC	
Plan Date: May 26, 2020	Reviewed By: Jeff Ingham		
Prepared By: Oz Zayyat	RKA Project Number: 20013		
3			
2			
1			
Rev. No.	By	Date	Description of Revision

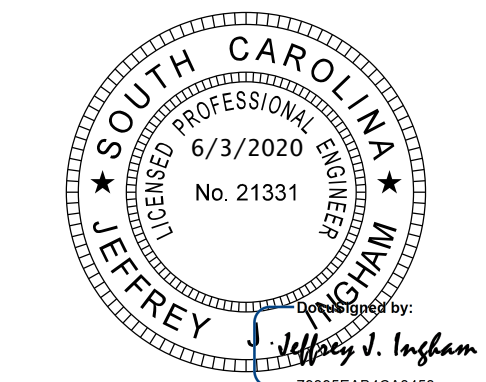
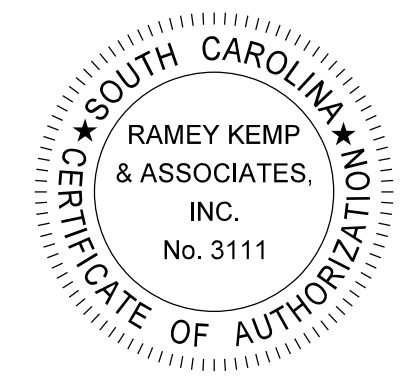

TEAMS ID:

\$\$\$\$\$path\$\$\$\$\$filename\$\$\$\$\$cut\$\$\$\$\$

SIGNAL EQUIPMENT

ONE (1) NEW 8-PHASE FULLY ACTUATED STANDARD 2070 CONTROLLER WITH FLASHER, SIGNAL MONITOR UNIT, AND BASE-MOUNTED 332A CABINET.
4 ORACLE, (2)-CHANNEL VEHICLE DETECTOR UNITS

CABINET: EXT. PROP.

VEHICLE SIGNALS: EXT. PROP.

PEDESTRIAN SIGNALS: EXT. PROP.

HEAD NUMBER	1,2F	2	6	8	2P	8P
LENS						
PHASE	1,OLA	2	6	8	2P	8P
SIZE	12"	12"	12"	12"	16"	16"
QUANTITY	1	2	2	2	2	4

OLA:Ø1 + Ø2 (FYA) OLC:
OLB: OLD:

METAL POLES W/O MAST ARMS: EXT. PROP.

METAL POLES W/ MAST ARMS: EXT. PROP.

WOOD POLES AS NECESSARY: EXT. PROP.

SPLICE BOXES AS NECESSARY: EXT. PROP.

INDUCTANCE LOOPS AS NECESSARY: EXT. PROP.

GUYS AS NECESSARY: EXT. PROP.

WIRELESS DETECTORS AS NECESSARY: EXT. PROP.

TABLE OF OPERATION	PHASE IN OPERATION			
	Ø1 + Ø6	Ø2 + Ø6	Ø8	FLASH
1,2F	←G	←FY	←R	←FY
2	R	G	R	Y
6	G	G	R	Y
8	R	R	G	R
2P	DW	W	DW	DRK
8P	DW	DW	W	DRK

SIGNAL TIMINGS

	PHASE							
	1	2	3	4	5	6	7	8
WALK	-	7	-	-	-	-	-	7
DON'T WALK	-	40	-	-	-	-	-	25
MIN INITIAL	6	15	-	-	-	15	-	8
MAX INITIAL	-	37	-	-	-	37	-	-
ADD/VEH	-	1.6	-	-	-	1.6	-	-
VEH EXT	2.5	6.0	-	-	-	6.0	-	3.0
TIM BFR REDUC	-	25	-	-	-	25	-	-
TIME TO REDUC	-	20	-	-	-	20	-	-
MIN GAP	-	2.5	-	-	-	2.5	-	-
MAX LIMIT	15	60	-	-	-	60	-	35
MAXIMUM 2	-	-	-	-	-	-	-	-
YELLOW	3.0	4.5	-	-	-	4.5	-	3.0
RED CLEAR	3.9	2.4	-	-	-	2.4	-	3.0

LOOP DETECTOR INSTALLATION CHART

PHASE/ LOOP LTR#	DETECTOR AMP NO.	CHAN NO.	WIRED TO				OPERATION		SPECIAL FEATURES	LOOP DESIGN		
			PHASE(S)	LOCK	NON-LOCK	PULSE	DELAY SEC	EXT SEC		SIZE	NO.OF TURNS	DIST. FROM
1A	1	-	1	-	X	-	-	-	QUADRUPOLE	6' X 30'	2-4-2	-3'
2A	2	-	2	X	-	-	-	-	-	6' X 6'	6	330'
2B	2	-	2	X	-	-	-	-	-	6' X 6'	6	330'
6A	3	-	6	X	-	-	-	-	-	6' X 6'	6	330'
6B	3	-	6	X	-	-	-	-	-	6' X 6'	6	330'
8A	4	-	8	-	X	-	-	-	QUADRUPOLE	6' X 30'	2-4-2	-3'
8B	4	-	8	-	X	-	-	-	QUADRUPOLE	6' X 30'	2-4-2	-3'

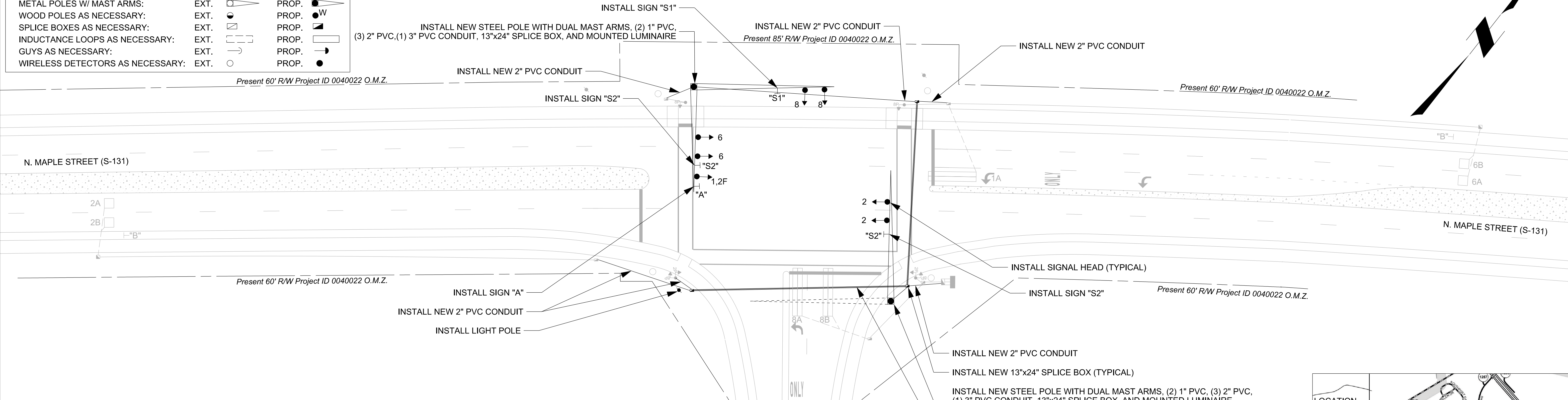

NEMA PHASING

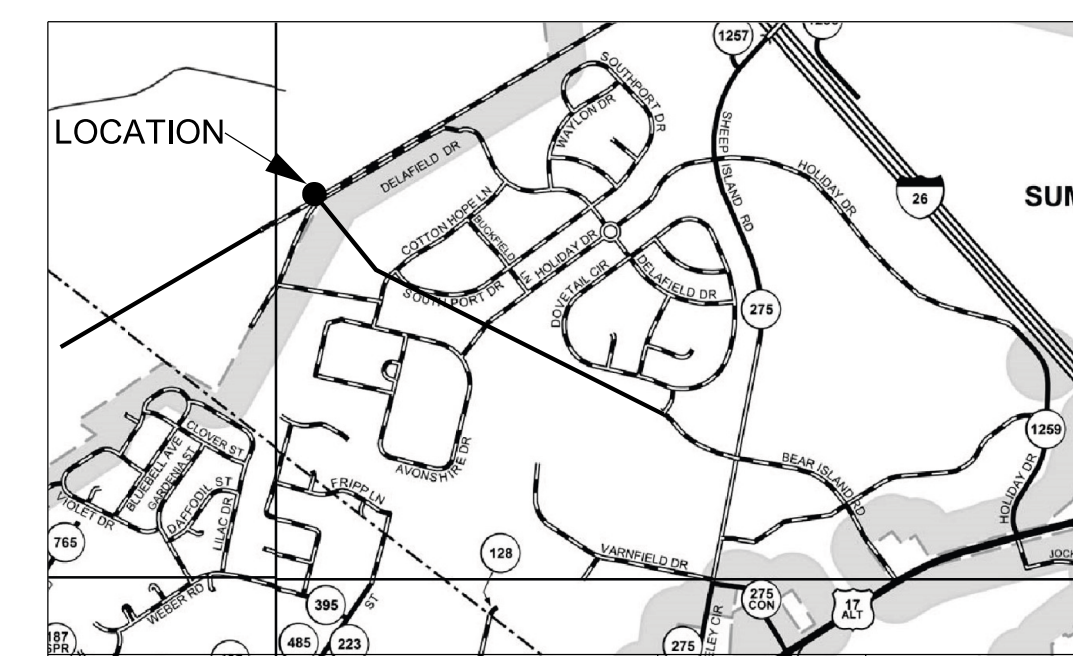
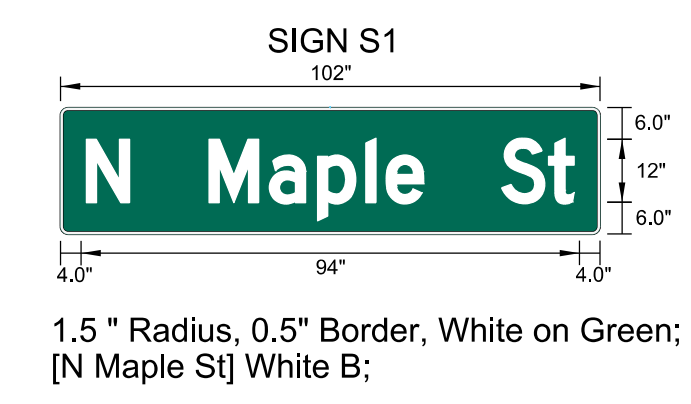
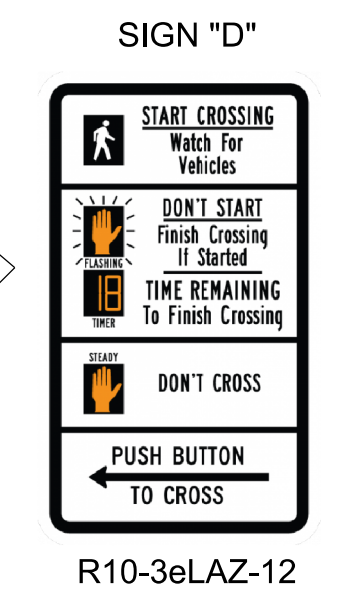
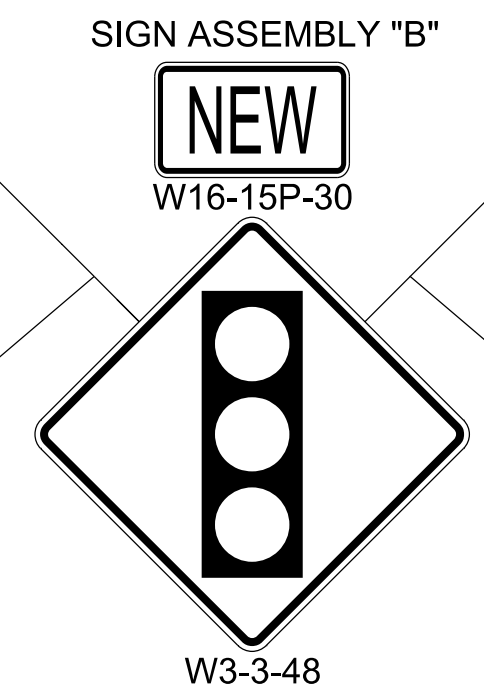
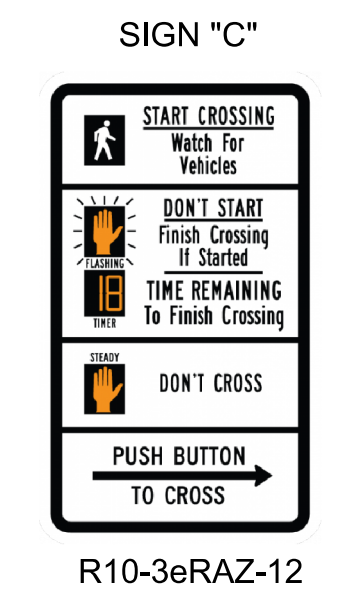
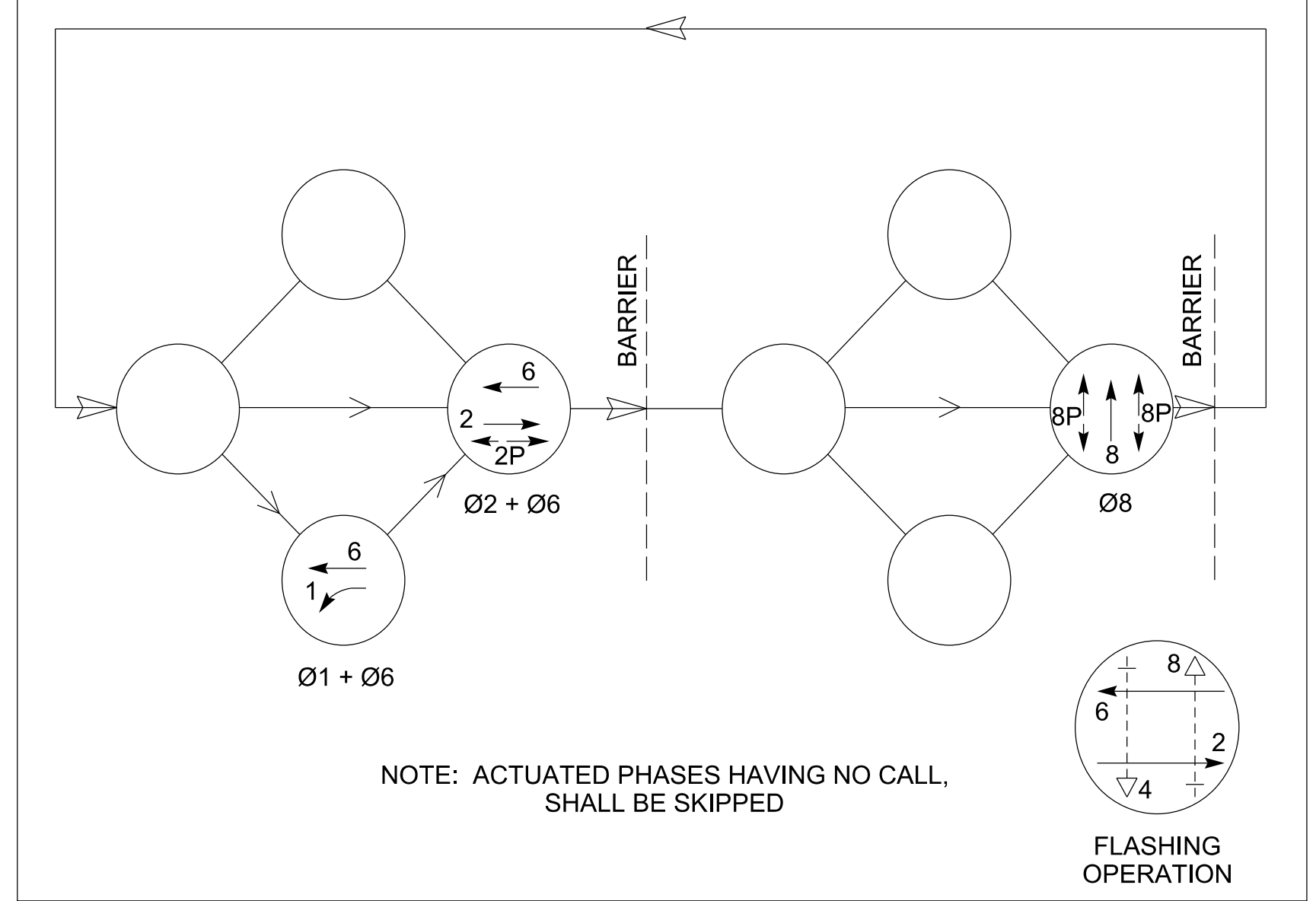

ROUTE NUMBER	S-131	BEAR ISLAND ROAD
APPROACH DIRECTION	EB WB NB SB	
SIGNAL DESIGN SPEED (MPH)	45 45 25 -	
GRADE (%)	0.32%-0.32% 0%	

* ESTIMATED FROM PROJECT ID 0040022

\$\$\$\$\$path\$\$\$\$\$filename\$\$\$\$\$\$\$\$\$\$



Prepared By:
RKA
RAMEY KEMP ASSOCIATES
7301 Rivers Avenue
Suite 242
North Charleston, SC 29406
Phone: 843-614-3800
www.rameykemp.com

Prepared For:			
TRAFFIC SIGNAL PLAN N. MAPLE STREET (S-131) at BEAR ISLAND ROAD			
District 6	Berkeley County	Summerville, SC	
Plan Date: May 26, 2020	Reviewed By: Jeff Ingham		
Prepared By: Oz Zayyat	RKA Project Number: 20013		
3			
2			
1			
Rev. No.	By	Date	Description of Revision

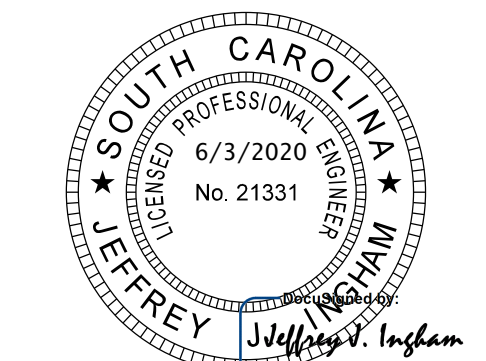
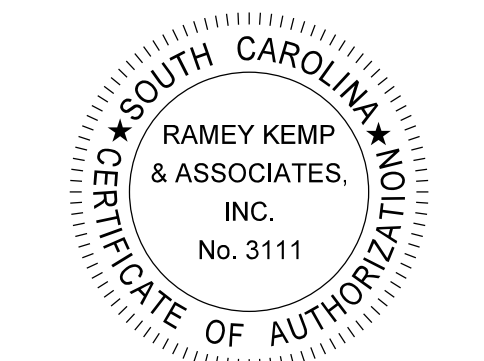

TEAMS ID:

Clearance Distances

Left Turn Movements

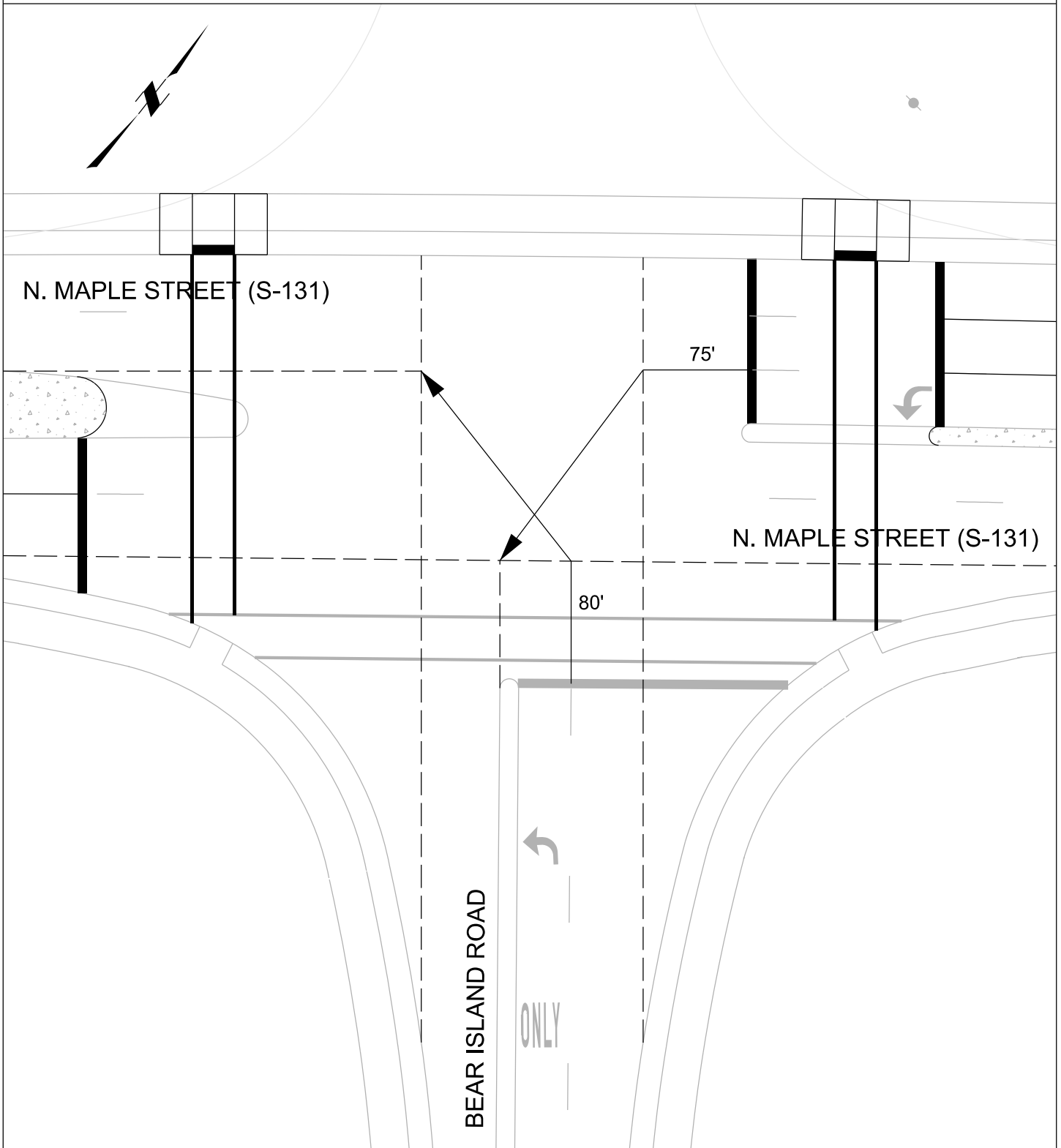

Prepared By:



7301 Rivers Avenue
Suite 242
North Charleston, SC 29406

Phone: 843-614-3800
www.rameykemp.com

N. MAPLE STREET (S-131)
at
BEAR ISLAND ROAD
SUMMERVILLE, SOUTH CAROLINA

Legend

XX' Clearance Distance For Movement
(Used to Calculate Clearance Intervals)

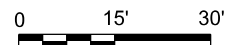

Clearance Distances

Through & Pedestrian Movements

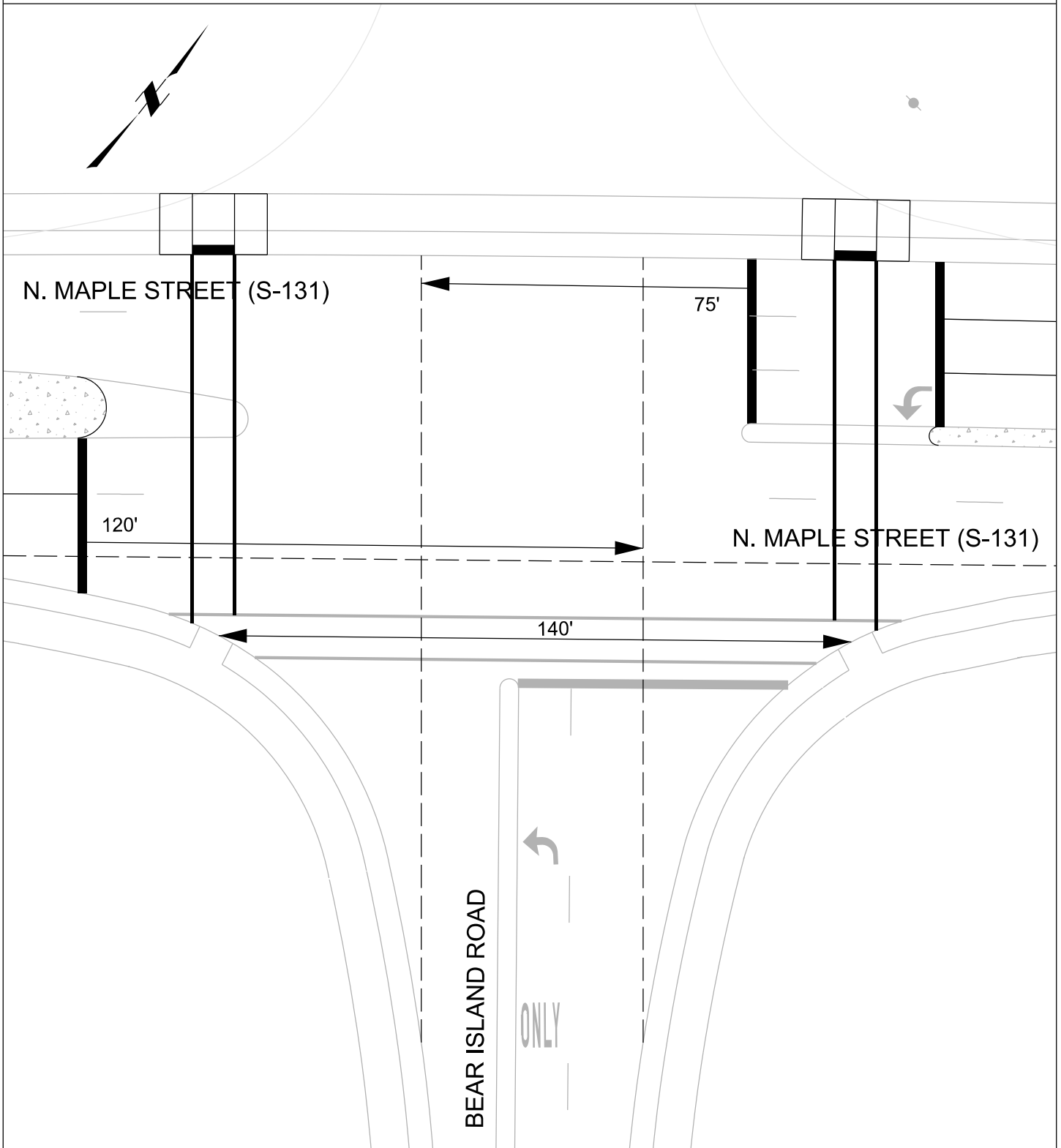

Prepared By:



7301 Rivers Avenue
Suite 242
North Charleston, SC 29406
Phone: 843-614-3800
www.rameykemp.com

N. MAPLE STREET (S-131)
at
BEAR ISLAND ROAD
SUMMERVILLE, SOUTH CAROLINA

Legend

XX' Clearance Distance For Movement
(Used to Calculate Clearance Intervals)

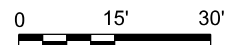

Clearance Time Calculations

Rev 2015-01-12

City:	Summerville	District:	6
County:	Berkeley	Sig. ID #	
NB Street:	Bear Island Road	Project #:	
SB Street:		Computed by:	RKA
EB Street:	N. Maple Street	Checked by:	
WB Street:	N. Maple Street	Approved by:	

Movement	Street Name	Bear Island Road				N. Maple Street		N. Maple Street	
		Northbound		Southbound		Eastbound		Westbound	
		Left	Thru	Left	Thru	Left	Thru	Left	Thru
NEMA Phase #	Protected		8				2	1	6
	Permissive	8						6	
FYA								Y	
Speed	mph	20	25	20	25	20	45	20	45
	ft/sec	29.33	36.67	29.33	36.67	29.33	66.00	29.33	66.00
Grade	%	0.00%		0.00%		0.32%		-0.32%	
	Elevation at Stopbar, ft								
	Elevation at Setback, ft								
	Dist to Setback, ft								
	-OR- Enter Grade, %	0.00%		0.00%		0.32%		-0.32%	
Clear Distance	feet	80					120	115	115
Ped Cross Dist	feet		85				140		
Parameters	Percept-React Time, sec	1.0	1.0	1.0	1.0	1.0	1.0	1.0	1.0
	Decel Rate, ft/sec ²	10.0	10.0	10.0	10.0	10.0	10.0	10.0	10.0
	Walk Speed, fps	3.5	3.5	3.5	3.5	3.5	3.5	3.5	3.5
Recommended:	Phase #		8				2	1	6
Yellow	sec		3.0				4.4	3.0	4.5
All Red	sec		3.0				2.2	3.9	2.4
Flashing Don't Walk	sec		25.0				40.0		

NOTES:

Compute times only as needed for plan.

Yellow change interval should be between 3 and 6 seconds.

Red clearance intervals less than 1.5 and more than 4.0 seconds require special circumstances.

Grades are rounded to the conservative whole percent.

Yellow and All Red times are rounded up to the next tenth of a second.

Ped clearance time is rounded up to the next whole second.

SIGNAL EQUIPMENT

ONE (1) NEW 8-PHASE FULLY ACTUATED STANDARD 2070 CONTROLLER WITH FLASHER, SIGNAL MONITOR UNIT, AND BASE-MOUNTED 332A CABINET.
6 ORACLE, (2)-CHANNEL VEHICLE DETECTOR UNITS

CABINET: EXT. PROP.
VEHICLE SIGNALS: EXT. PROP.

HEAD NUMBER	1,2F	2	3,4F	4	6	8	2P	4P	6P	8P
LENS										
PHASE	1,OLA	2	3,OLB	4	6	8	2P	4P	6P	8P
SIZE	12"	12"	12"	12"	12"	12"	16"	16"	16"	16"
QUANTITY	1	2	1	2	2	2	2	2	2	2

OLA: Ø1 + Ø2 (FYA) OLC:
OLB: Ø3 + Ø4 (FYA) OLD:

METAL POLES W/O MAST ARMS: EXT. PROP.
METAL POLES W/ MAST ARMS: EXT. PROP.
WOOD POLES AS NECESSARY: EXT. PROP.
SPLICE BOXES AS NECESSARY: EXT. PROP.
INDUCTANCE LOOPS AS NECESSARY: EXT. PROP.
GUYS AS NECESSARY: EXT. PROP.
WIRELESS DETECTORS AS NECESSARY: EXT. PROP.

SIGNAL TIMINGS

INTERVAL	PHASE							
	1	2	3	4	5	6	7	8
WALK	-	7	-	7	-	7	-	7
DON'T WALK	-	20	-	23	-	20	-	23
MIN INITIAL	6	15	6	8	-	15	-	8
MAX INITIAL	-	30	-	-	-	30	-	-
ADD/VEH	-	-	-	-	-	-	-	-
VEH EXT	-	-	-	-	-	-	-	-
TIM BFR REDUC	-	-	-	-	-	-	-	-
TIME TO REDUC	-	-	-	-	-	-	-	-
MIN GAP	-	2.5	-	-	-	2.5	-	-
MAX LIMIT	15	60	15	30	-	60	-	30
MAXIMUM 2	-	-	-	-	-	-	-	-
YELLOW	3.0	3.0	3.0	3.0	-	3.0	-	3.0
RED CLEAR	3.5	3.5	3.1	3.3	-	3.5	-	3.3

NEMA PHASING

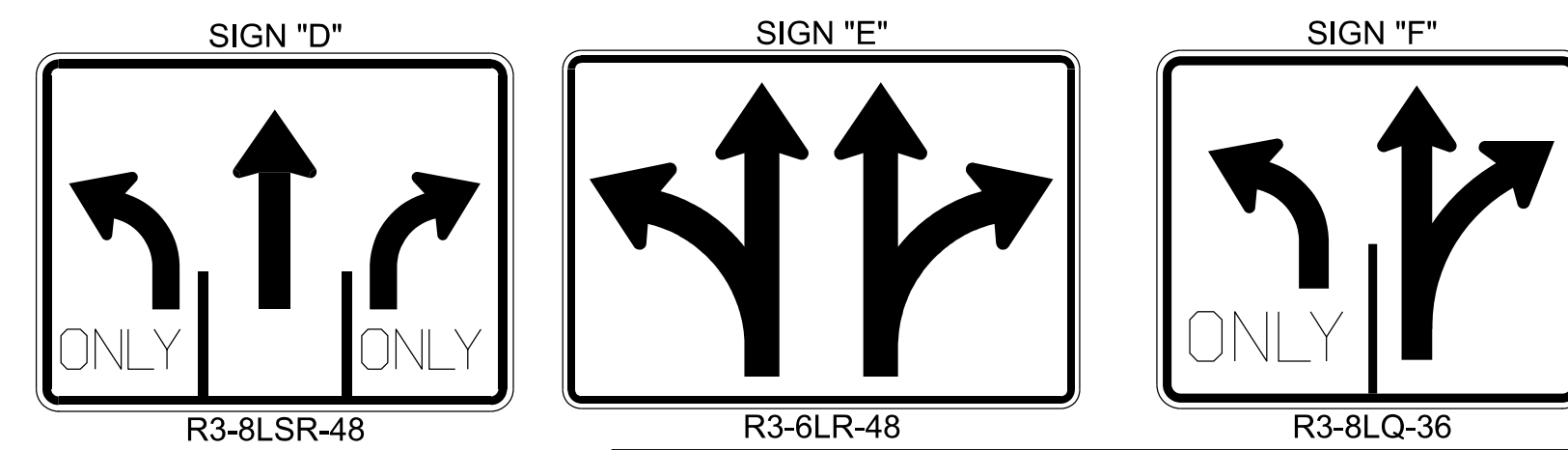
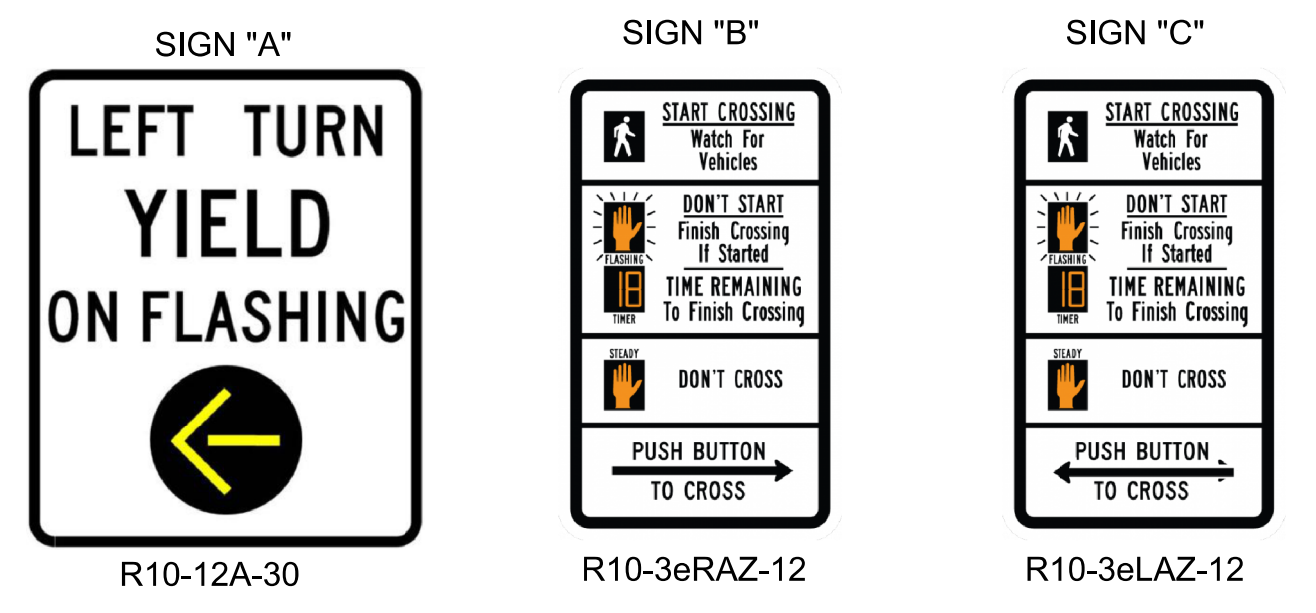
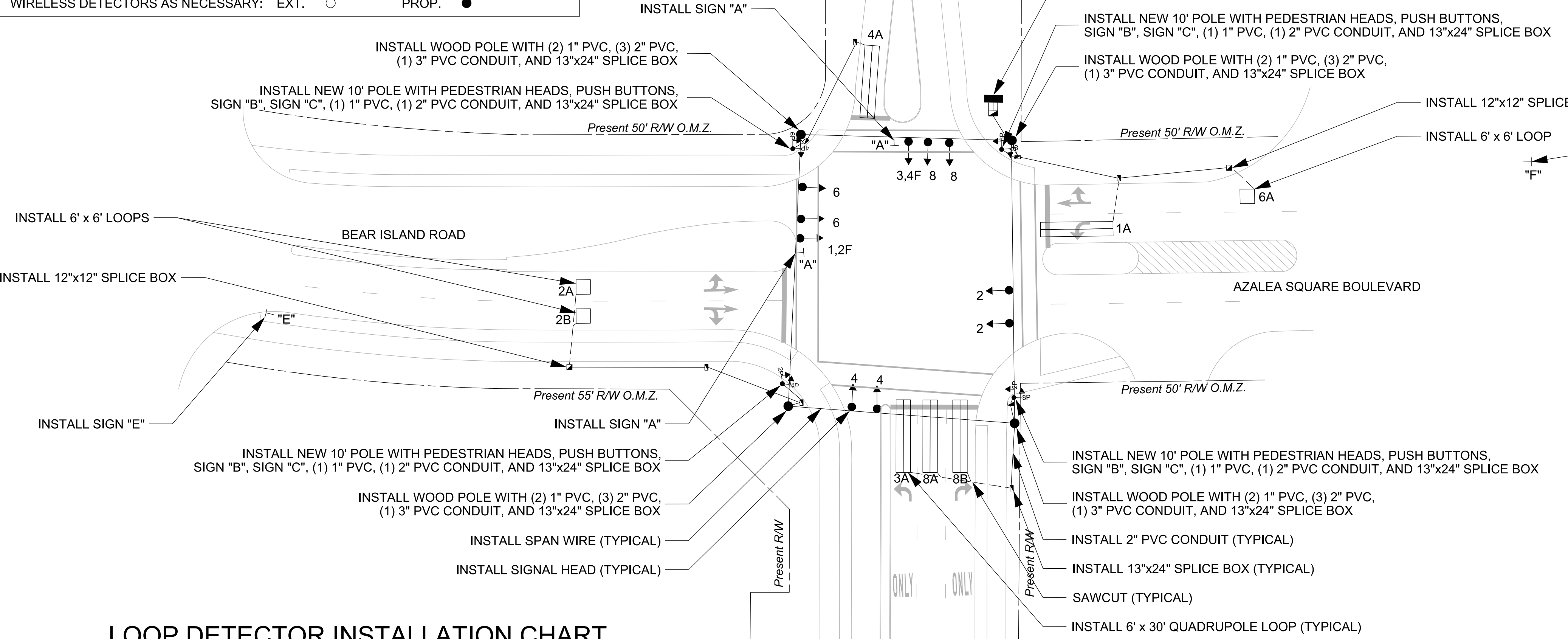
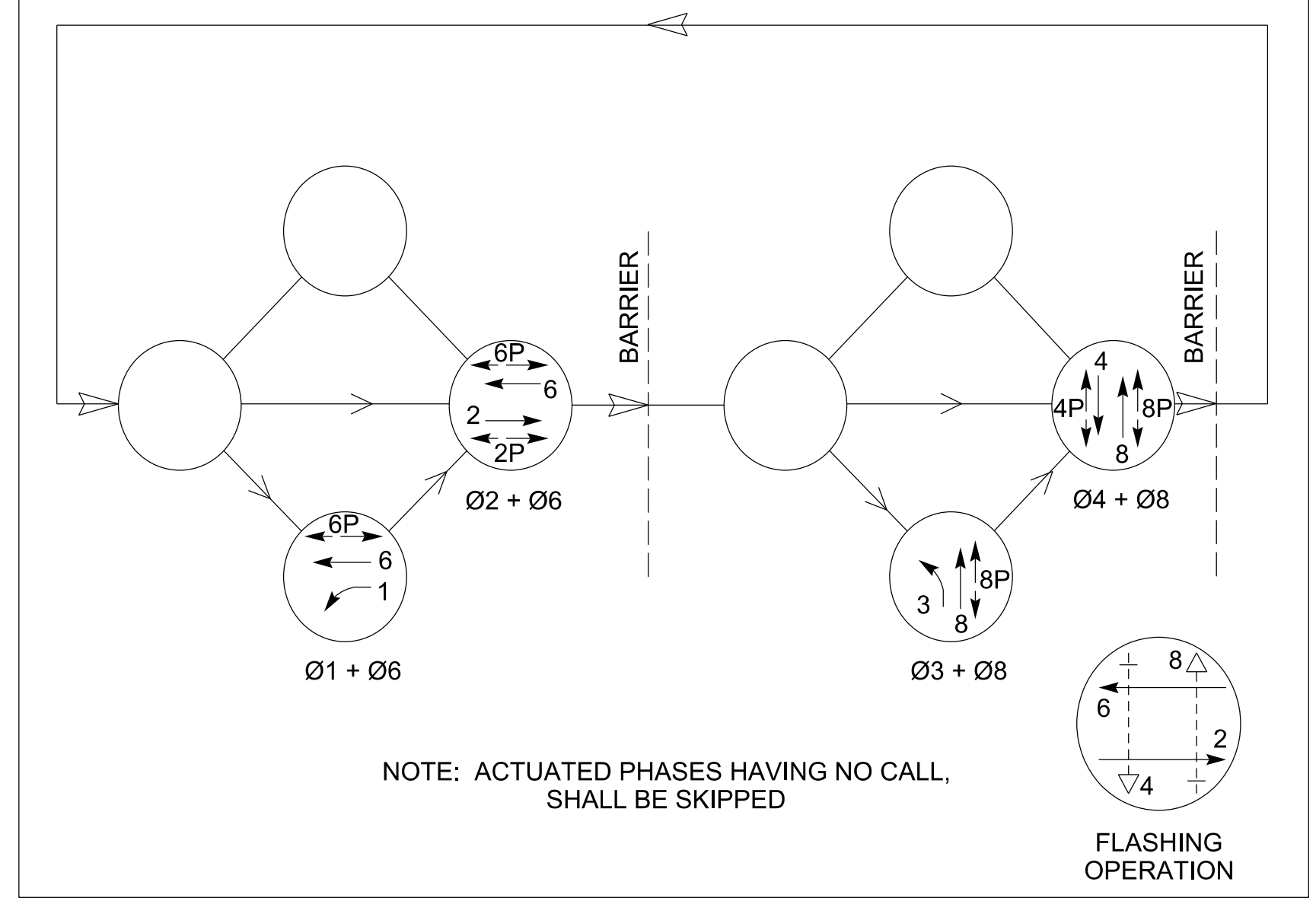

LOOP DETECTOR INSTALLATION CHART

PHASE/ LOOP LTR#	DETECTOR		WIRED TO PHASE(S)	LOCK	NON-LOCK	PULSE	PRES	OPERATION	SPECIAL FEATURES	LOOP DESIGN		
	AMP NO.	CHAN NO.								SIZE	NO. OF TURNS	DIST. FROM
1A	1	-	1	-	X	-	X	-	QUADRUPOLE	6' X 30'	2-4-2	-3'
2A	2	-	2	X	-	-	X	-	-	6' X 6'	6	80'
2B	2	-	2	X	-	-	X	-	-	6' X 6'	6	80'
3A	3	-	3	-	X	-	X	-	QUADRUPOLE	6' X 30'	2-4-2	-3'
4A	4	-	4	-	X	-	X	-	QUADRUPOLE	6' X 30'	2-4-2	-3'
6A	5	-	6	X	-	-	X	-	-	6' X 6'	6	80'
8A	6	-	8	-	X	-	X	-	QUADRUPOLE	6' X 30'	2-4-2	-3'
8B	6	-	8	-	X	-	X	-	QUADRUPOLE	6' X 30'	2-4-2	-3'

TABLE OF OPERATION	PHASE IN OPERATION					
	SIGNAL HEAD #	Ø1 + Ø6	Ø2 + Ø6	Ø3 + Ø8	Ø4 + Ø8	FLASH
1,2F	←G	←FY	←R	←R	←FY	
2	R	G	R	R	Y	
3,4F	←R	←R	←G	←FY	←R	
4	R	R	R	G	R	
6	G	G	R	R	Y	
8	R	R	G	G	R	
2P	DW	W	DW	DW	DRK	
4P	DW	DW	DW	W	DRK	
6P	W	W	DW	DW	DRK	
8P	DW	DW	W	W	DRK	

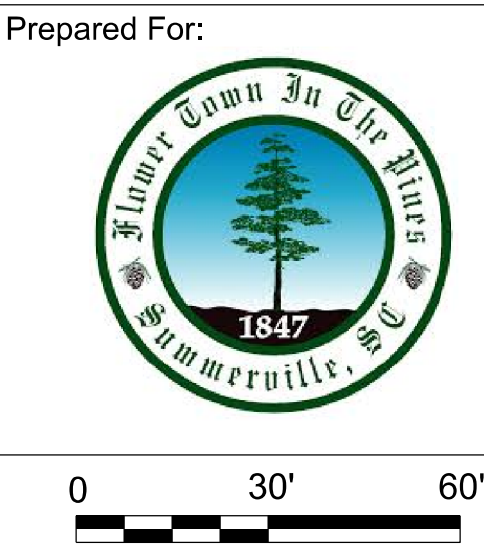
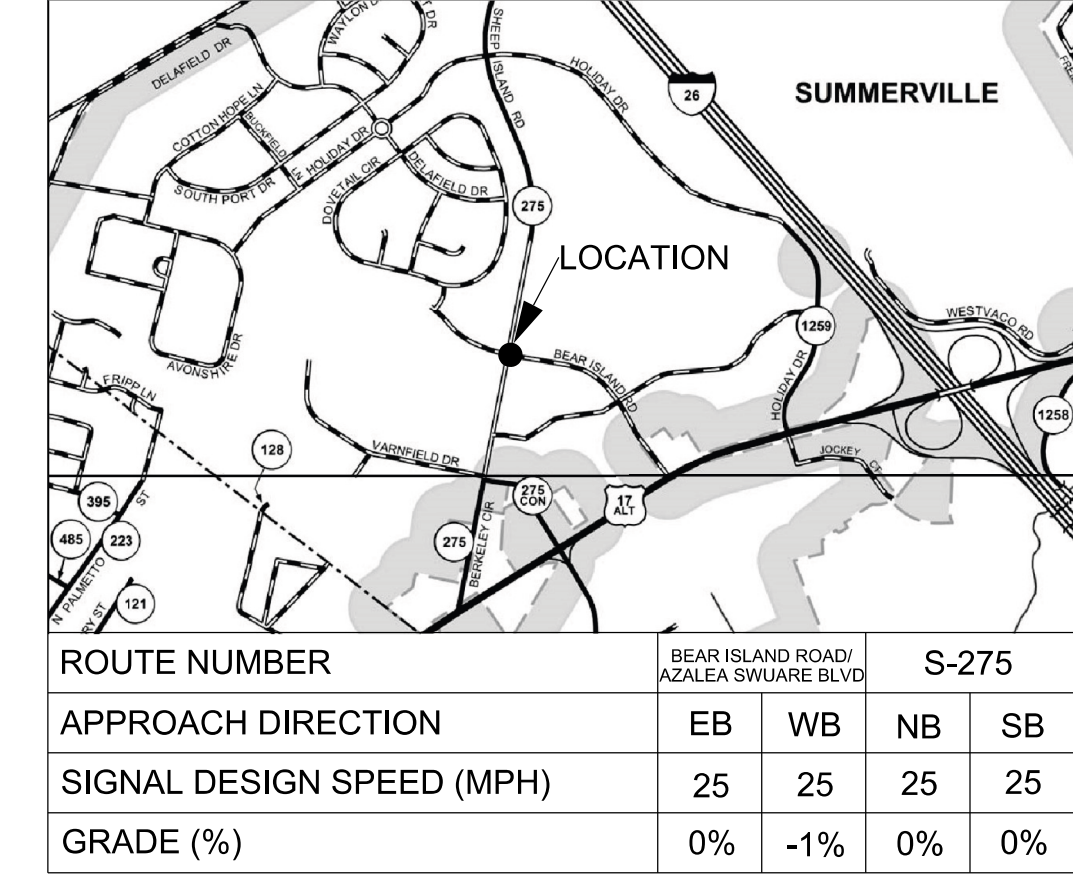

Prepared For:
TEMPORARY TRAFFIC SIGNAL PLAN
BEAR ISLAND ROAD/AZALEA SQUARE BLVD
at
OLD LIGHT ROAD (S-275)
District 6 Berkeley County Summerville, SC
Plan Date: May 26, 2020 Reviewed By: Jeff Ingham
Prepared By: Oz Zayyat RKA Project Number: 20013

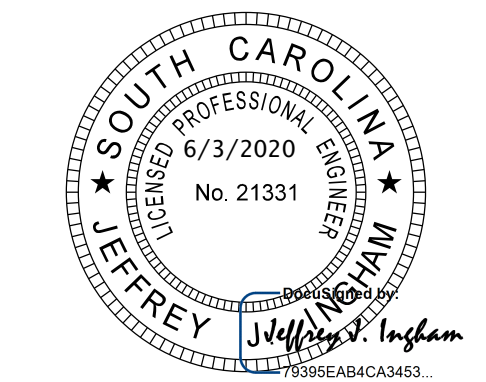

Prepared By:
RKA
RAMEY KEMP ASSOCIATES
7301 Rivers Avenue
Suite 242
North Charleston, SC 29406
Phone: 843-614-3800
www.rameykemp.com

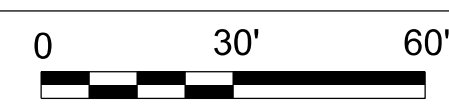

Rev. No.	By	Date	Description of Revision
3			
2			
1			

TEAMS ID:

\$\$\$\$\$path\$\$\$\$\$filename\$\$\$\$\$OUT\$\$\$\$\$

SIGNAL EQUIPMENT

ONE (1) NEW 8-PHASE FULLY ACTUATED STANDARD 2070 CONTROLLER WITH FLASHER, SIGNAL MONITOR UNIT, AND BASE-MOUNTED 332A CABINET.
6 ORACLE, (2)-CHANNEL VEHICLE DETECTOR UNITS

CABINET: EXT. PROP.
VEHICLE SIGNALS: EXT. PROP.

PEDESTRIAN SIGNALS: EXT. PROP. W/ACT & SIGN

HEAD NUMBER	1,2F	2	3,4F	4	6	8	2P	4P	6P	8P
LENS	←R ←FY ←G	R Y G	←R ←FY ←G	R Y G	R Y G	R Y G				
PHASE	1,OLA	2	3,OLB	4	6	8	2P	4P	6P	8P
SIZE	12"	12"	12"	12"	12"	12"	16"	16"	16"	16"
QUANTITY	1	2	1	2	2	2	2	2	2	2

OLA: Ø1 + Ø2 (FYA) OLC:
OLB: Ø3 + Ø4 (FYA) OLD:

METAL POLES W/O MAST ARMS: EXT. PROP. M
METAL POLES W/ MAST ARMS: EXT. PROP. W
WOOD POLES AS NECESSARY: EXT. PROP. W
SPLICE BOXES AS NECESSARY: EXT. PROP. W
INDUCTANCE LOOPS AS NECESSARY: EXT. PROP. W
GUYS AS NECESSARY: EXT. PROP. W
WIRELESS DETECTORS AS NECESSARY: EXT. PROP. W

SIGNAL TIMINGS

INTERVAL	PHASE							
	1	2	3	4	5	6	7	8
WALK	-	7	-	7	-	7	-	7
DON'T WALK	-	20	-	23	-	20	-	23
MIN INITIAL	6	15	6	8	-	15	-	8
MAX INITIAL	-	30	-	-	-	30	-	-
ADD/VEH	-	-	-	-	-	-	-	-
VEH EXT	-	-	-	-	-	-	-	-
TIM BFR REDUC	-	-	-	-	-	-	-	-
TIME TO REDUC	-	-	-	-	-	-	-	-
MIN GAP	-	2.5	-	-	-	2.5	-	-
MAX LIMIT	15	60	15	30	-	60	-	30
MAXIMUM 2	-	-	-	-	-	-	-	-
YELLOW	3.0	3.0	3.0	3.0	-	3.0	-	3.0
RED CLEAR	3.5	3.5	3.1	3.3	-	3.5	-	3.3

NEMA PHASING

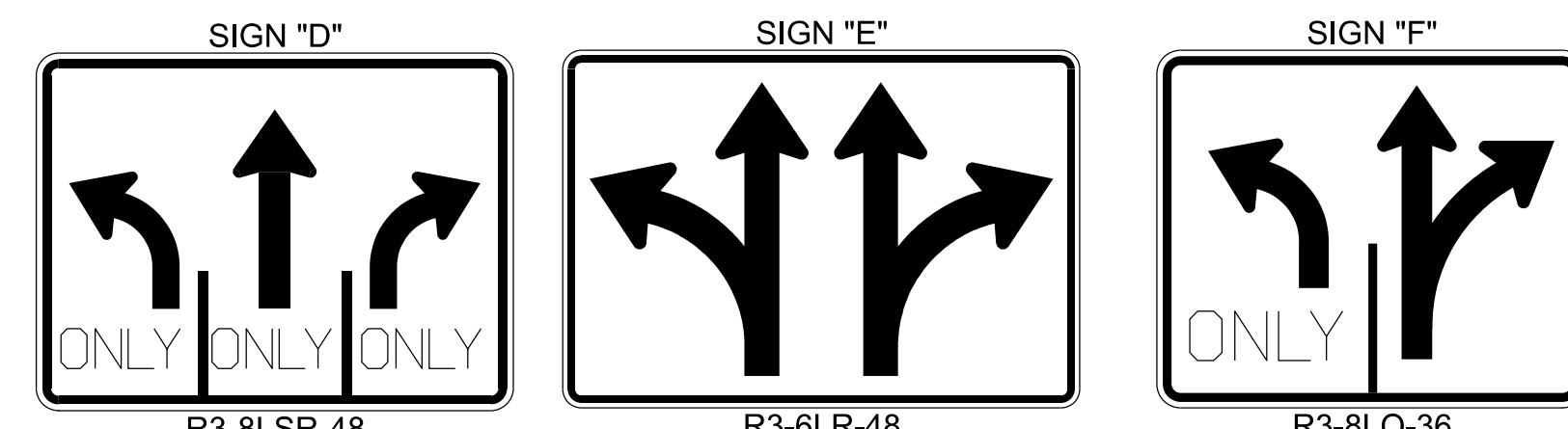
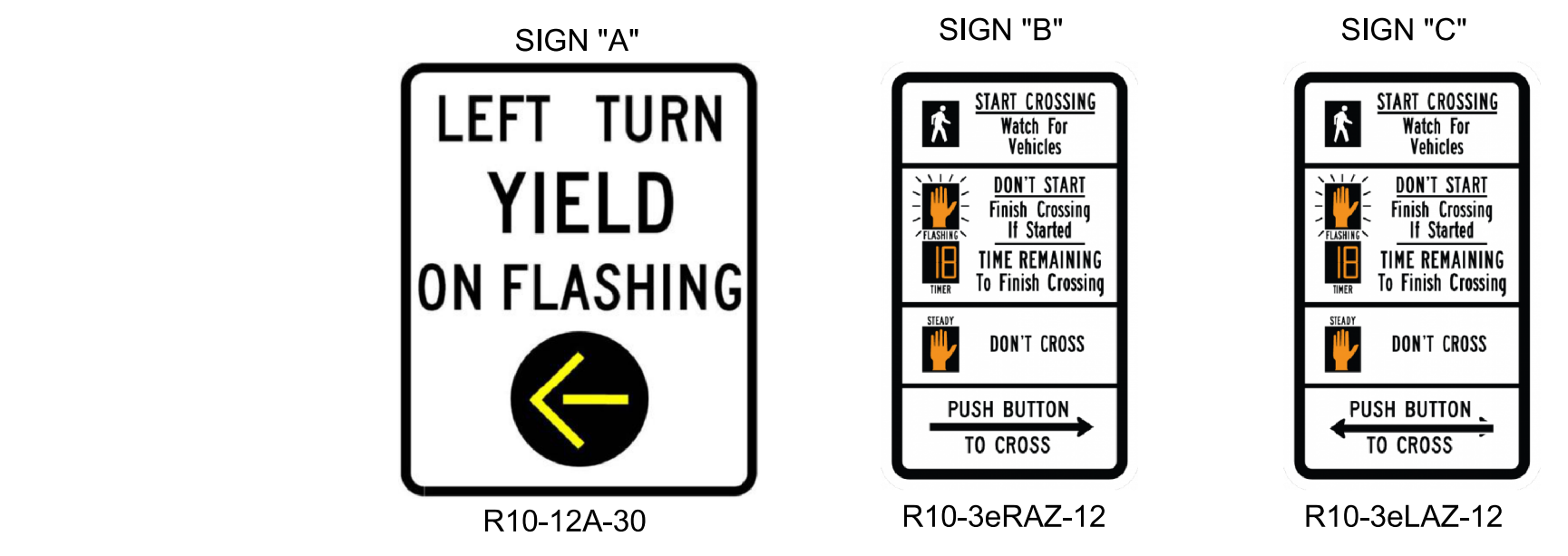
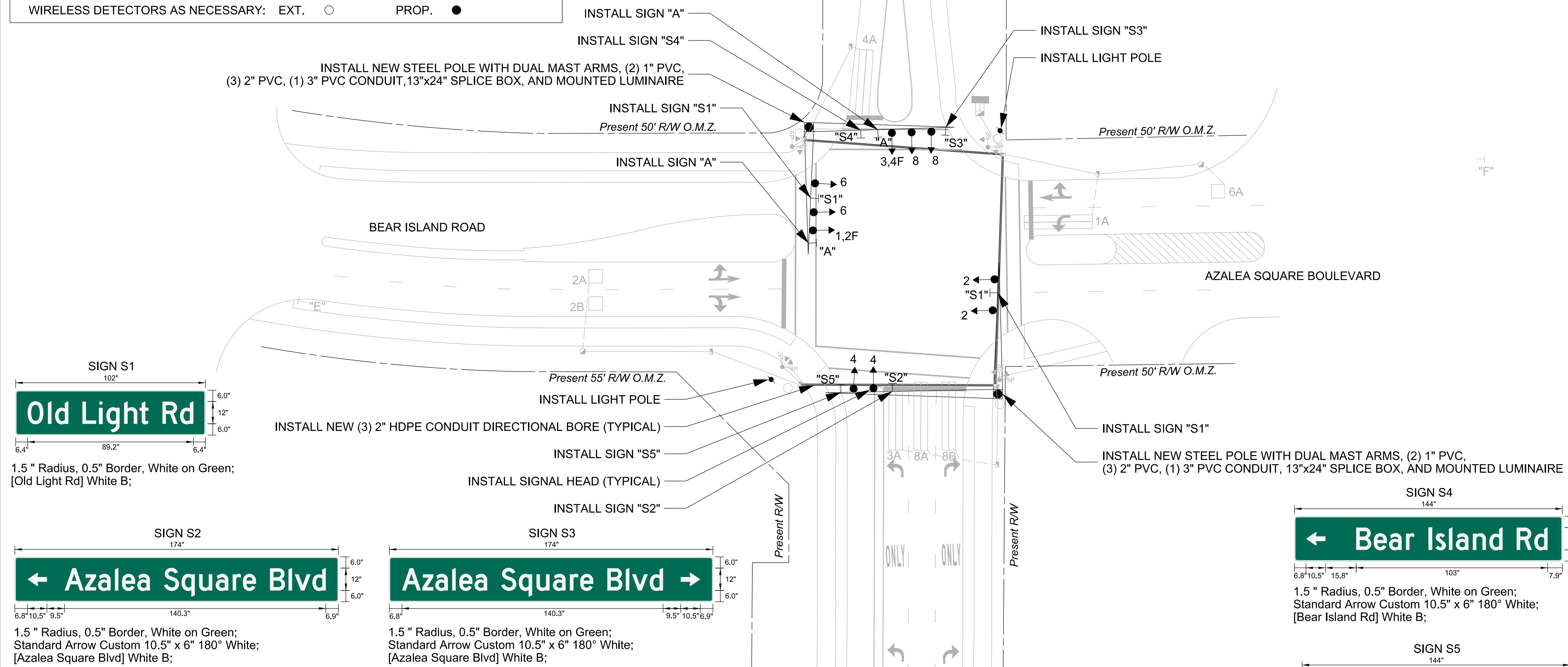
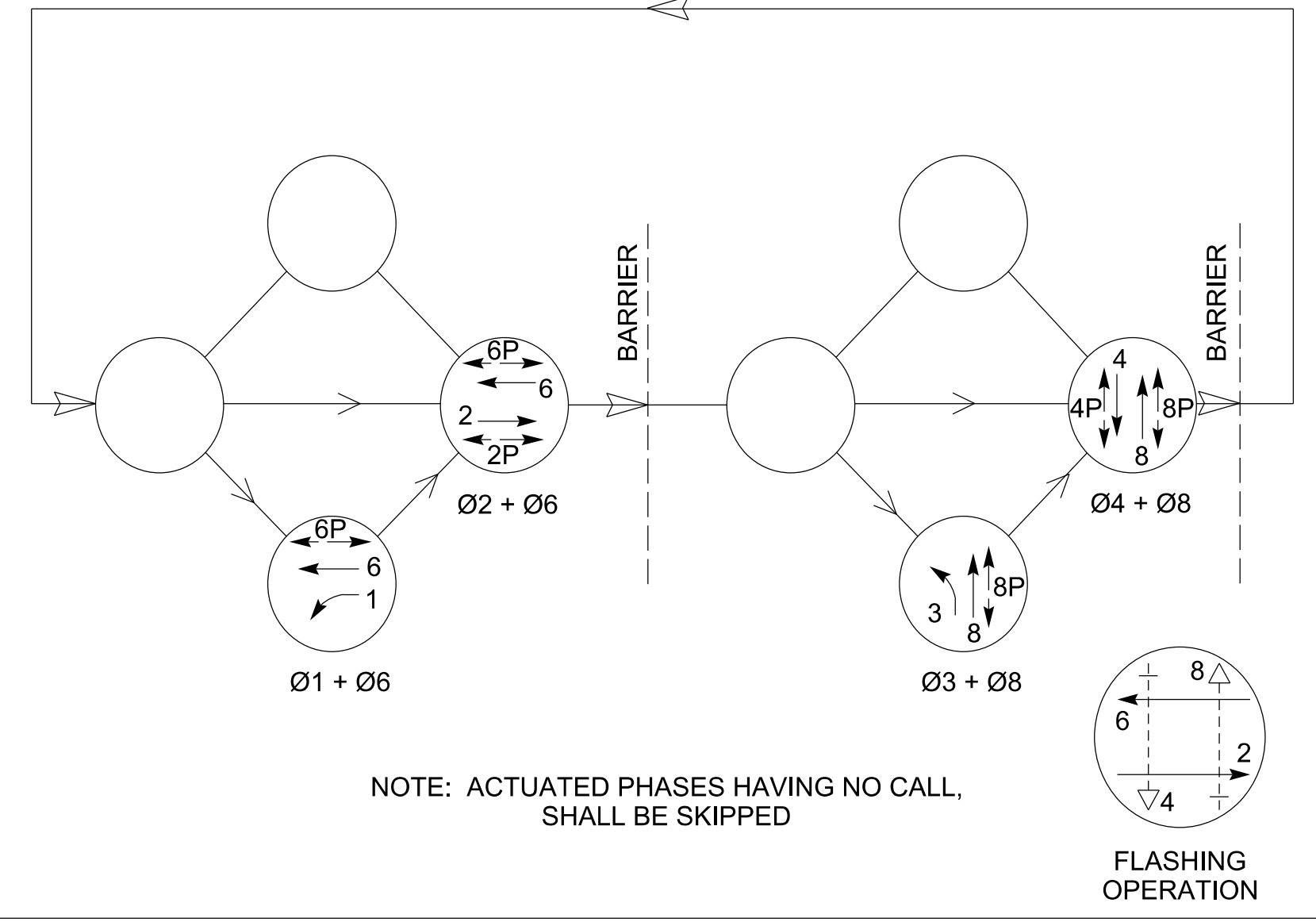

LOOP DETECTOR INSTALLATION CHART

PHASE/ LOOP LTR#	DETECTOR		WIRED TO PHASE(S)	LOCK	NON-LOCK	PULSE	PRES	OPERATION		SPECIAL FEATURES	LOOP DESIGN		
	AMP NO.	CHAN NO.						DELAY SEC	EXT SEC		SIZE	NO. OF TURNS	DIST. FROM
1A	1	-	1	-	X	-	X	-	-	QUADRUPOLE	6' X 30'	2-4-2	-3'
2A	2	-	2	X	-	-	X	-	-	-	6' X 6'	6	80'
2B	2	-	2	X	-	-	X	-	-	-	6' X 6'	6	80'
3A	3	-	3	-	X	-	X	-	-	QUADRUPOLE	6' X 30'	2-4-2	-3'
4A	4	-	4	-	X	-	X	-	-	QUADRUPOLE	6' X 30'	2-4-2	-3'
6A	5	-	6	X	-	-	X	-	-	-	6' X 6'	6	80'
8A	6	-	8	-	X	-	X	-	-	QUADRUPOLE	6' X 30'	2-4-2	-3'
8B	6	-	8	-	X	-	X	-	-	QUADRUPOLE	6' X 30'	2-4-2	-3'

TABLE OF OPERATION	PHASE IN OPERATION									
	Ø1 + Ø6	Ø2 + Ø6	Ø3 + Ø8	Ø4 + Ø8	FLASH					
SIGNAL HEAD #	1,2F	2	3,4F	4	6	8	2P	4P	6P	8P
	←G	R	←R	←R	←R	←R	DW	DW	DW	DRK
	←FY	G	←FY	←FY	←FY	←FY	W	W	W	DRK
	←G	R	←R	←R	←R	←R	DW	DW	DW	DRK

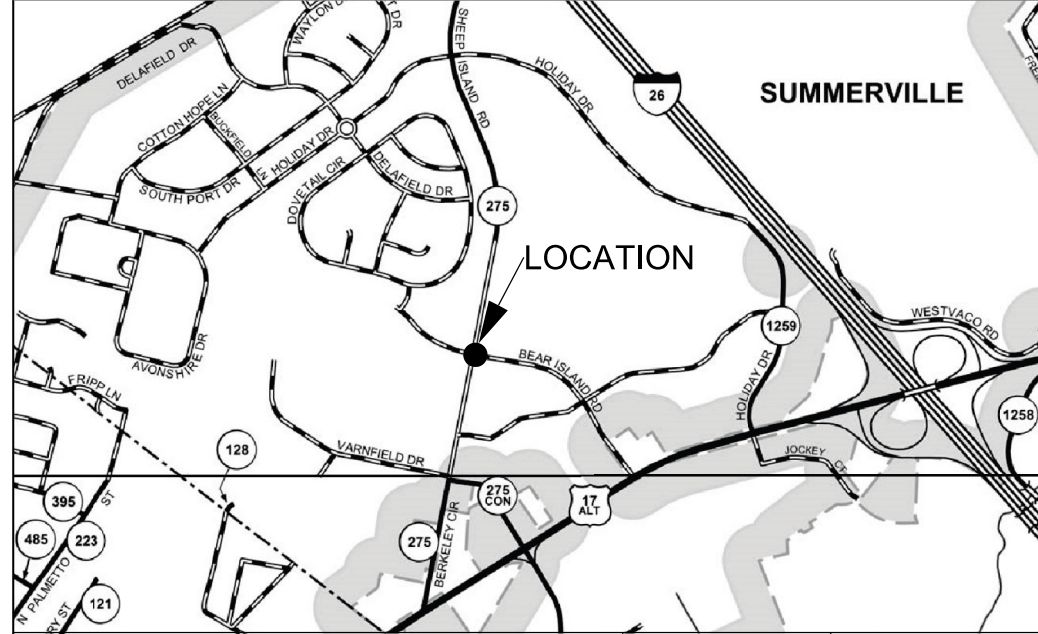

ROUTE NUMBER	BEAR ISLAND ROAD / AZALEA SQUARE BLVD	S-275
APPROACH DIRECTION	EB WB NB SB	
SIGNAL DESIGN SPEED (MPH)	25 25 25 25	
GRADE (%)	0% -1% 0% 0%	



Prepared By:
RKA
RAMEY KEMP ASSOCIATES
7301 Rivers Avenue
Suite 242
North Charleston, SC 29406
Phone: 843-614-3800
www.rameykemp.com

TRAFFIC SIGNAL PLAN			
BEAR ISLAND ROAD/AZALEA SQUARE BLVD at OLD LIGHT ROAD (S-275)			
District 6	Berkeley County	Summerville, SC	
Plan Date: May 26, 2020	Reviewed By: Jeff Ingham		
Prepared By: Oz Zayyat	RKA Project Number: 20013		
3			
2			
1			
Rev. No.	By	Date	Description of Revision

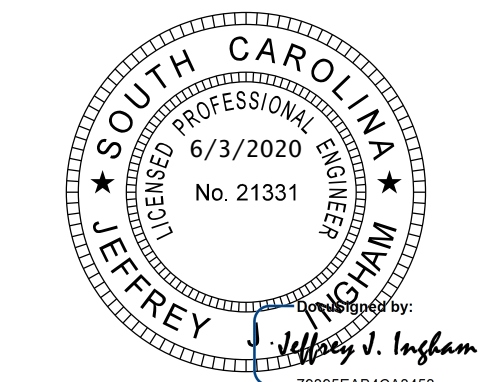
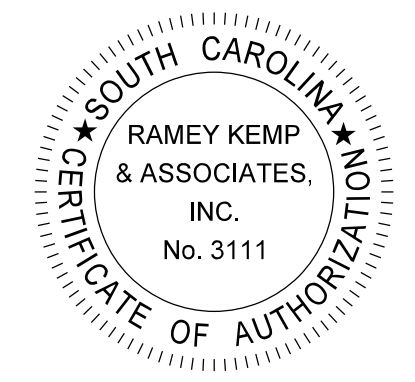

TEAMS ID:

\$\$\$\$\$paths\$\$\$\$\$filename\$\$\$\$\$

Clearance Distances

Left Turn Movements

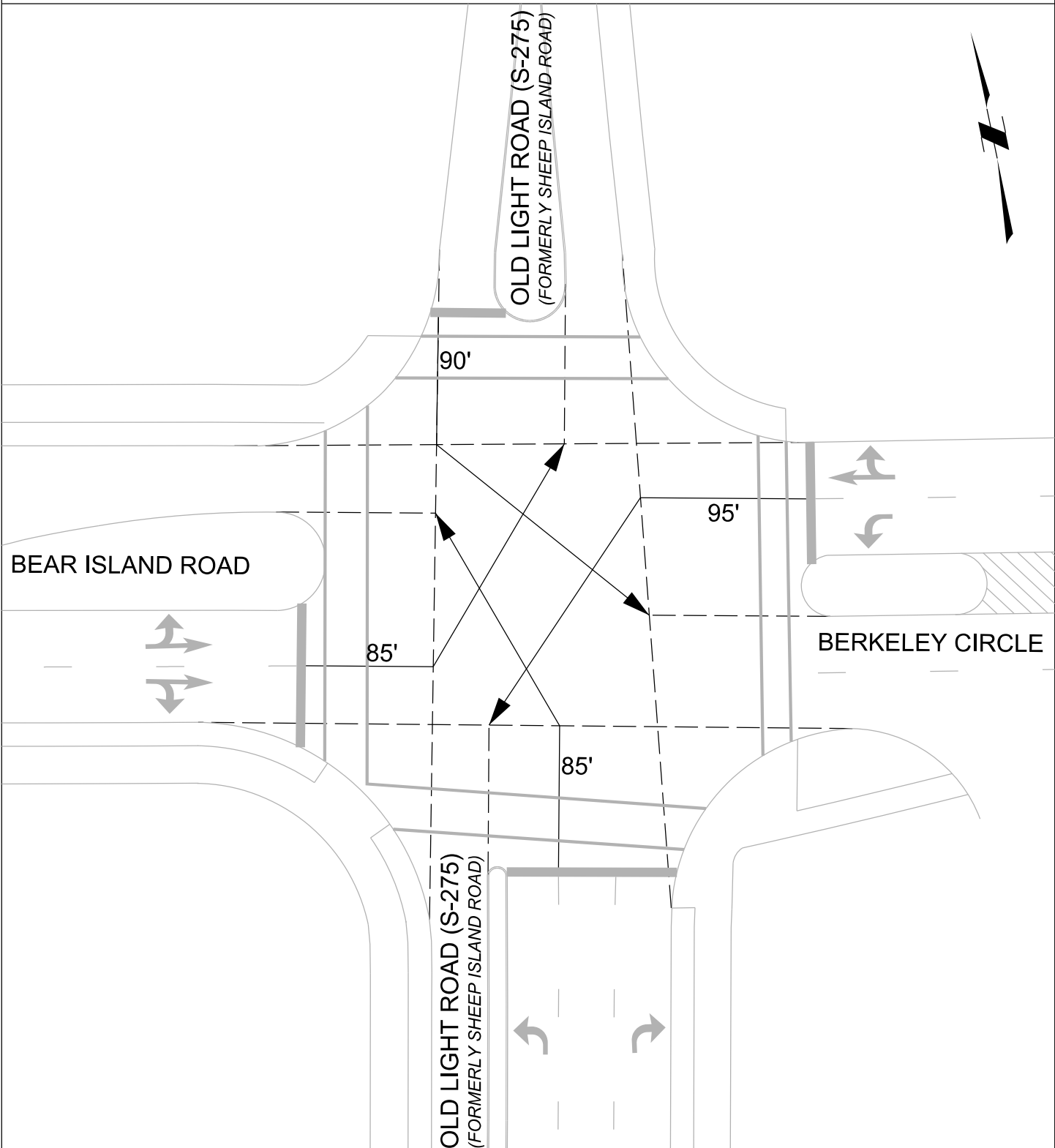

Prepared By:



RAMEY KEMP ASSOCIATES

7301 Rivers Avenue
Suite 242
North Charleston, SC 29406

Phone: 843-614-3800
www.rameykemp.com

BEAR ISLAND ROAD/AZALEA SQUARE BLVD
at
OLD LIGHT ROAD (S-275)
SUMMERVILLE, SOUTH CAROLINA

Legend

XX' Clearance Distance For Movement
(Used to Calculate Clearance Intervals)

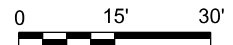

Clearance Distances

Through & Pedestrian Movements

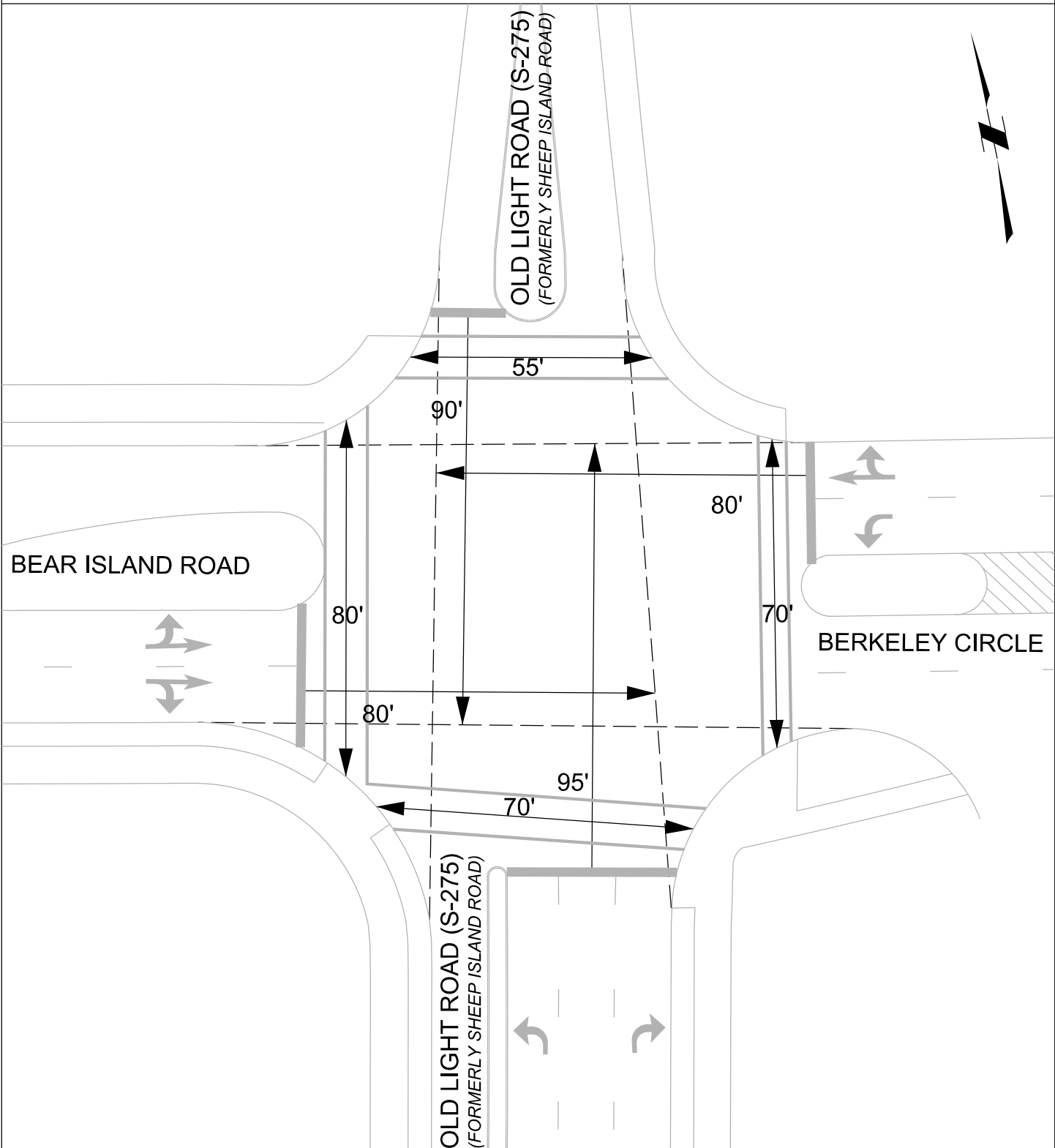

Prepared By:



7301 Rivers Avenue
Suite 242
North Charleston, SC 29406
Phone: 843-614-3800
www.rameykemp.com

BEAR ISLAND ROAD/AZALEA SQUARE BLVD
at
OLD LIGHT ROAD (S-275)
SUMMERVILLE, SOUTH CAROLINA

Legend

XX' Clearance Distance For Movement
(Used to Calculate Clearance Intervals)

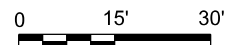

Clearance Time Calculations

Rev 2015-01-12

City:	Summerville	District:	6
County:	Berkeley	Sig. ID #	
NB Street:	Old Light Road	Project #:	
SB Street:	Old Light Road	Computed by:	RKA
EB Street:	Bear Island Road	Checked by:	
WB Street:	Azalea Square Blvd	Approved by:	

Movement	Street Name	Old Light Road		Old Light Road		Bear Island Road		Azalea Square Blvd	
		Northbound		Southbound		Eastbound		Westbound	
		Left	Thru	Left	Thru	Left	Thru	Left	Thru
NEMA Phase #	Protected	3	8		4		2	1	6
	Permissive	8		4		2		6	
FYA		Y						Y	
Speed	mph	20	25	20	25	20	25	20	25
	ft/sec	29.33	36.67	29.33	36.67	29.33	36.67	29.33	36.67
Grade	%	0%		0%		0%		-1%	
	Elevation at Stopbar, ft								
	Elevation at Setback, ft								
	Dist to Setback, ft								
	-OR- Enter Grade, %	0%		0%		0%		-1%	
Clear Distance	feet	85	95	90	90	85	80	95	80
Ped Cross Dist	feet		70		80		70		55
Parameters	Percept-React Time, sec	1.0	1.0	1.0	1.0	1.0	1.0	1.0	1.0
	Decel Rate, ft/sec ²	10.0	10.0	10.0	10.0	10.0	10.0	10.0	10.0
	Walk Speed, fps	3.5	3.5	3.5	3.5	3.5	3.5	3.5	3.5
Recommended:	Phase #	3	8		4		2	1	6
Yellow	sec	3.0	3.0		3.0		3.0	3.0	3.0
All Red	sec	3.1	3.3		3.3		3.1	3.5	3.5
Flashing Don't Walk	sec		20.0		23.0		20.0		16.0

NOTES:

Compute times only as needed for plan.

Yellow change interval should be between 3 and 6 seconds.

Red clearance intervals less than 1.5 and more than 4.0 seconds require special circumstances.

Grades are rounded to the conservative whole percent.

Yellow and All Red times are rounded up to the next tenth of a second.

Ped clearance time is rounded up to the next whole second.