

County of Curry



Invitation to Bid No. 2020/21-09

5th Street Parking Lot Construction

Issue Date:

APRIL 26, 2021

BID Due:

May 11, 2021

Time: 2:00 p.m. Mountain Time

**Curry County Administrative Complex
417 Gidding, Suite 100
Clovis, NM 88101**

**Curry County Administrative Complex
Bid No. 2020/21-09 5th Street Parking Lot Construction
Page 2 Commodity Class #91375 #91394**

On behalf of the Board of Curry County Commissioners and pursuant to and in compliance with the NM State Procurement Code, Curry County hereby invites competitive sealed bids submitted electronically to construct parking area improvements at 210 5th Street, Clovis NM.

**IMPORTANT:
BIDS ARE DUE BY MAY 11, 2021 AT 2:00 P.M.**

IN THE WAKE OF THE COVID-19 PUBLIC HEALTH EMERGENCY AND TO MINIMIZE PUBLIC HEALTH RISK, BIDS MUST BE SUBMITTED ELECTRONICALLY THROUGH CURRY COUNTY'S PROCUREMENT PROVIDER, VENDOR REGISTRY. REGISTRATION AND ACCESS TO ALL DOCUMENTS IS FREE OF CHARGE. TO REGISTER, PLEASE VISIT THE LINK: [FREE VENDOR REGISTRATION](#). BIDS WILL BE TIME-STAMPED IN THE VENDOR REGISTRY SYSTEM WHEN BIDDER SUBMITS. THE BIDDER WILL RECEIVE AN EMAIL OF THE SUBMISSION FOR THEIR RECORDS. SUCH ELECTRONIC SUBMISSION WILL BE CONSIDERED SEALED BIDS IN CONFORMANCE WITH STATUTE.

WE LOOK FORWARD TO YOUR BID SUBMISSION.

IF THERE IS ANY PROBLEM REGARDING THE FOLLOWING BID SPECIFICATIONS OR CONDITIONS THAT WOULD PREVENT YOU FROM SUBMITTING A BID, CONTACT THE ASSISTANT FINANCE DIRECTOR/CHIEF PROCUREMENT OFFICER BY EMAIL AT thall@currycounty.org IMMEDIATELY FOR CLARIFICATION OR CONSIDERATION OF AN ADDENDUM.

BIDS MUST BE SUBMITTED ELECTRONICALLY

Troy Hall
Curry County Assistant Finance Director
thall@currycounty.org

SPECIFIC CONDITIONS

Bids must be received electronically by MAY 11, 2021 at 2:00 p.m. Mountain Time. Sealed bids will be publicly opened online via GoogleMeet. Instructions for participating in the meeting are as follows:

Meeting ID

meet.google.com/aii-sfew-uvd



Phone Numbers

[\(US\)+1 240-412-2450](tel:+12404122450)

PIN: 857 458 079#

[More phone numbers](#)

1. **Criteria for Award**: Award shall be based on the lowest responsible bid price which meets all specifications. The Board of Curry County Commissioners reserves the right to reject any or all bids, to waive any technicalities and to accept the bid(s) which in its judgment is most advantageous to the County.
2. **Guaranteed Performance**: The bidder, if awarded a contract as a result of this bid, guarantees that services will conform to the specifications in this bid. Failure of the bidder to comply with providing a service which meets minimum specifications may result in termination of the award of that item or termination of the contract.

SCOPE OF WORK

Bidder shall provide street and storm drainage improvements, including construction of paving, and other miscellaneous items of work in compliance to the Plans, Specifications, Contract Documents for this project. Bidders are required to remove obstructions including concrete sidewalks and curbs as noted in the project plans. Installation shall include roadway surfacing, concrete drive pads, curbs, gutters, site lighting, irrigation, landscaping, etc. that will be paid on a unit price basis and the bidder will be paid for actual quantities installed.

Bidder shall subgrade and construct base course with asphalt and concrete pavement surfacing to designated areas as shown in the project plans.

Bidder shall ensure the site is cleaned and properly maintained at all times.

Prices bid shall include all major labor, equipment, materials and preparation costs to construct the parking lot improvements at the listed project site.

The bidder is responsible for on-site inspections and to bid this appropriately. County will not be responsible for any mistakes that are made in bidder's figures and computations.

GENERAL

Bid Prices shall include all major labor, equipment, materials and preparation costs to construct the parking lot at the listed project site.

**Curry County Administrative Complex
Bid No. 2020/21-09 5th Street Parking Lot Construction
Page 4 Commodity Class #91375 #91394**

Bidder agrees to comply with state laws and rules pertaining to Worker's Compensation insurance coverage for its employees. If bidder fails to comply with the Worker's Compensation Act and applicable rules, when required to do so, the contract may be cancelled effective immediately.

All bids shall be subject to the requirements of Section 102 of the New Mexico State Department of Transportation Standard Specifications for Highway and Bridge Construction, Edition of 2014.

PLANS AND SPECIFICATIONS

The Plans and Specifications are attached to this Invitation to Bid and may be obtained for public inspection at the Curry County Administration Office, 417 Gidding Street, Suite 100 and at the office of Lydick Engineers and Surveyors, Inc., 205 E 2nd Street, Clovis, NM. These Bid documents, plans, specifications and all addenda supplementary plans, specifications and documents, if any, are essential parts of the contract. They are intended to be complementary, to describe and provide for complete work. In case of discrepancy, figured dimensions, unless obviously incorrect, shall govern over scaled dimensions.

The bidder shall not take advantage of any apparent error or omission in the Plans and Specifications. In the case the bidder discovers an apparent error or discrepancy, they shall immediately email the Assistant Finance Director for clarification and issuance of an addendum.

CONTRACT

The contract shall become effective May 18, 2021 upon approval by the Board of County Commissioners and the terms and conditions herein shall be binding upon and continue until terminated by either party, as set forth herein. Bidder agrees to begin the project within ten (10) calendar days from issuance of the Notice to Proceed from County and agrees to complete the project no later than 60 calendar days after receipt of Notice to Proceed.

The contract shall not become effective until the same is approved in writing by the Curry County Board of County Commissioners. The successful bidder shall, within ten (10) days execute and deliver to the County the agreement and other required forms included in the Invitation to Bid. The successful bidder shall furnish surety bonds in a sum not less than the amount of the Contract as awarded, as security for the faithful performance of the Contract, and for the payment of all persons, firms or corporations to whom the bidder may become legally indebted for labor, materials, tools, equipment, or services of any nature, including utility and transportation services employed or used in performing the work. The current power of attorney for the person who signs for any surety company shall be attached to such bond. The bonds shall be issued by a Surety licensed to conduct business in the State of New Mexico and named in the current list of "Surety Companies Acceptable on Federal Bonds" as published in the Federal Register by the Audit Staff, bureau of Accounts, U.S. Treasury Department.

If a successful bidder fails to execute the agreement, other required forms, and the required bonds within ten days after the prescribed forms are presented for signature (or within an extended time period as the County may

grant), the County may either award the Contract to the next lowest responsible bidder or re-advertise for bids and may charge against the bidder the amount of the bid security, not as a penalty, but in liquidated liquidation of damages sustained. If a more favorable bid is received by re-advertising, the defaulting bidder shall have no claim against the County for a refund.

TERMINATION

In the event of termination pursuant to this paragraph, the County's only liability shall be to pay bidder for acceptable goods delivered and services rendered before the termination date.

The contract may also be terminated by either party hereto for cause upon fifteen (15) calendar day's written notice in the event of substantial failure by the other party to perform in accordance with the terms of the contract through no fault of the terminating party.

Upon receipt of notice of termination from County, bidder shall discontinue the services unless otherwise directed and upon final payment from County deliver to the County the required data, reports, summaries, and such other information and materials as may have been accumulated by bidder.

PRE-BID CONFERENCE

A pre-bid conference is not scheduled. Should you have questions regarding the scope of work, please contact Troy Hall by email at thall@currycounty.org. Curry County highly encourages bidders to make a site visit and familiarize themselves with the area, as they will be held responsible for all requirements, as outlined in the scope of work.

BID SECURITY

Each bidder shall submit a certified check or a satisfactory bid bond provided by a surety company authorized to do business in the State of New Mexico in an amount equal to (5%) five percent of the total amount of the bid, with each bid proposal. The security is required as outlined in Section 13-1-146 NMSA 1978.

PERFORMANCE BOND

This (performance bond) shall be required on any contract awarded in excess of (\$25,000) twenty-five thousand dollars. The successful bidder shall supply the County with a performance bond executed by a surety company authorized to do business in the state of New Mexico with said surety to be approved by the State Board of Finance in the amount of 100% of the total bid price. This bond is required as outlined in Section 13-4-18 (A)(1) of NMSA 1978.

PAYMENT BOND

This (payment bond) shall be required on any contract awarded in excess of (\$25,000) twenty-five thousand dollars. The successful bidder shall supply the County with a payment bond executed by a surety company authorized to do business in the State of New Mexico with said surety to be approved by

the State Board of Finance in the amount of 100% of the total bid price. This bond is for the protection of all persons supplying labor and materials to the contractor or its subcontractors for the performance of the work provided in the contract and is required as outlined in Section 13-4-18 (A)(1) of NMSA 1978.

NOTICE TO PROCEED

The Bidder shall proceed with work within ten (10) working days from issuance of the notice to proceed, unless arrangements have been made with the successful bidder prior to contract execution. **The County anticipates issuing the notice to proceed on May 18, 2021 and bidder is expected to start working within ten (10) working days from issuance.**

WARRANTIES

Upon and as a condition of County's acceptance of the completed work, bidder shall provide County with a written one (1) full year warranty on all materials and labor for the work performed by the bidder.

Said one (1) year full contractor workmanship warranty shall commence upon the date of the signed report of acceptance from County. Any problems, defects, or issues discovered by County or brought to the County's attention during said one (1) year period will be conveyed in writing to the bidder and bidder shall respond and repair or replace any and all said problems, defects or issues as quickly as possible, but no later than ten (10) working days after notification from County. In the event of an emergency, bidder agrees to repair said problems, defects or issues within seventy-two (72) hours of being notified by County. Said one (1) year workmanship warranty encompasses any and all problems, defects or issues that are discovered by County and for which notice has been given to bidder within said one (1) year period. Bidder shall repair and resolve any problems, defects or issues which it has been notified of regardless of whether the actual work occurs after the expiration of the one (1) year warranty or not.

Bidder shall also take whatever action is necessary to complete and ensure that all said manufacturers warranties used for completion of work are transferred/assigned in writing to County once the work has been completed and accepted by County.

WATER

The bidder shall provide and make arrangements for water required.

VARIATIONS

Any variations from, or exceptions to, the conditions and specifications of this bid must be listed on a separate sheet labeled "Exception(s) to Bid Conditions", and attached to the bid.

QUOTATION SHEETS

Bidders shall use the attached Quotation Sheet(s) to submit their bids. The Quotation Sheet(s) must be signed.

NEW MEXICO BIDDER'S PREFERENCE

Pursuant to Sections 13-1-21 & 13-4-2 NMSA 1978, and GSD Rule 1.4.1 NMAC, bidders claiming the 5% preference must be certified prior to the bid opening. The number must appear on the Quotation Sheet(s) in the space provided in order to receive the preference.

BID OPENING

Competitive bids will be accepted until Insert Date at 2:00 p.m. In the wake of the covid-19 public health emergency and to minimize public health risk, bids must be submitted electronically through curry county's procurement provider, vendor registry. Registration and access to all documents is free of charge. To register, please visit:

<https://www.currycounty.org/?splash=https%3a%2f%2fvrapp.vendorregistry.com%2fVendor%2fRegister%2fIndex%2fcurry-county-nm-vendor-registration&isexternal=true> .

Bids will be time-stamped in the vendor registry system when bidder submits. The bidder will receive an email of the submission for their records. Such electronic submission will be considered sealed bids in conformance with statute.

RESERVATIONS

The Curry County Commission reserves the right to reject any or all bids, to waive any technicalities, to accept in whole or in part such bid or bids as may be deemed in the best interest of the County.

BIDDER'S PRE-START REPRESENTATIONS

Bidders represent that they have familiarized themselves with and assumes full responsibility for having familiarized themselves with the nature and extent of the contract documents, work, locality, and with all local conditions including weather conditions, and federal, state and local laws, ordinances, rules and regulations that may in any manner affect performance of the work and represents that they have correlated their study and observations with the requirements of the contract documents.

Bidders are responsible for on-site inspections and to bid appropriately. County will not be responsible for any mistakes that are made in the bidder's figures and computations. Bidders shall visit the site of the proposed work, fully acquaint himself/herself with the existing conditions relating to the construction of the project, the facilities involved and the difficulties and restrictions attending the performance of the contract. Bidders shall thoroughly examine and familiarize themselves with the Plans, Specifications, and other Contract Documents. Bidders by the execution of the Contract shall not be relieved of any obligation thereunder due to failure to examine any form or legal instrument or to visit the site and acquaint himself with the conditions there existing. Any claims may be rejected based on facts regarding which should have been on notice as a result thereof.

UNIT PRICES

The Unit Price for each of the several items bid shall include its pro-rate share of overhead anticipated profit and other indirect costs that the sum of the products obtained by multiplying the quantity shown for each item by the Unit Price Bid represents the total bid. Any bid not conforming to this requirement may be rejected as irregular. In the event of an error in extensions in the amount column, the written price shall govern.

SAFETY REQUIREMENTS

It shall be the contractor's responsibility to provide for the safety of its workers and the public in compliance with the requirements of insurance and public health and safety standards.

With respect to all work performed, all bidder's shall:

1. Comply with the safety standard provisions of applicable laws, building and construction codes and the "manual of Accident General Contractors of America, the requirements of the Occupation Safety Health Act of 1970 (Public Law 91-596) and the requirements of Title 29 of the Code of Federal Regulations. Section 1518 as published in the "Federal Register", Volume 36, No. 75, Saturday, April 17, 1971;
2. Exercise every precaution at all times for the prevention of accidents and the protection of person (including employees) and property;
3. Maintain at its office or other well-known place at the job site, all articles necessary for giving first aid to the injured, and shall make standing arrangements for the immediate removal to a hospital or a doctor's care of persons (including employees), who may be injured on the job site. In no case shall employees be permitted to work at a job site before the employer has made a standing arrangement for removal of injured persons to a hospital or a doctor's care.

PUBLIC WORKS

This solicitation is for a Public Works Project and subject to the public works statues of the State of New Mexico (13-4-1 to 13-4-43 NMSA 1978); Construction Industries Licensing Act (60-13-1 et seq. NMSA 1978); CID Rules and Regulations; Applicable Federal, State and Local Statues and Laws; and the City of Clovis Ordinances.

SUBMITTALS

Each Bidder will furnish, when requested, printed literature and manufacturers specifications sheets that fully describe the material they propose to furnish the County. The acceptance or rejection of equals or equivalents shall be determined solely by the County or its representative.

SUBCONTRACTORS

The listing threshold for subcontractors for this project is **\$5,000** and shall be submitted in compliance with 13-4-32 thru 13-4-43 NMSA 1978. There shall be only one subcontractor listed for each classification. If subcontractors change according to bid options/additive alternates accepted than list the subcontractors and the bid lots where they are to be used.

The County reserves the right to disqualify subcontractors and suppliers in accordance with the conditions of the bid and contract. All bidders agree that they are fully responsible to the County for the acts and omissions of its subcontractors and or persons either directly or indirectly employed by them, as the bidder is for the acts and omissions of persons directly employed by the bidder. Nothing contained in the contract documents shall create any contractual relationship between any subcontractor and the County.

The bidder may be required to establish the reliability and responsibility of the proposed subcontracts or of any manufacturer to furnish and perform the work in accordance with the contract documents and completion schedule and may also be required to require performance and payment bonds of some or all subcontractors in conformance with sec. 13-4-37 NMSA 1978.

LICENSE AND PERMITS

Bidder shall insure that any and all subcontractors, suppliers and other persons/entities involved in the project comply with all laws, rules and regulations in effect, including, but not limited to the New Mexico Workman's Compensation laws. Bidder shall obtain or at least insure that all permits, licenses and inspections that are necessary or required for any work on the project are properly obtained and performed. Bidder must have its GA98 Contractors license.

CODE COMPLIANCE

Complete installation must meet federal, state, and local laws, codes and regulations.

INSPECTION

The County or its designee shall at all times have the right to inspect and approve the work and materials.

WAGES

Wages will be paid in accordance with the State of New Mexico Public Works Statues regarding Wage Rates. The Wage Decision number for this project is **CU-21-0717-A**. A Wage Rate Schedule is enclosed with this Bid. Contractor and all

tiers of subcontractors will submit certified weekly payrolls to the County Public Services Directly (BI-Weekly).

AWARD

The award may be made to the bidder providing a responsive, responsible bid that meets and satisfies all of the requirements herein and results in the lowest overall cost to the County. The award will be made by the Curry County Commission at their regularly scheduled meeting. Bid prices must be good for ninety (90) days subsequent to date of opening. The lowest bid will be based on the total aggregate bid of all lots and alternates.

PROTEST

Any bidder who is aggrieved in connection with this solicitation or award of a contract may protest to the County Assistant Finance Director. The protest shall be submitted in writing within fifteen (15) calendar days after contract award. Protests shall be written and shall include the name and address of the protestor and the Invitation to Bid number. It shall also contain a statement of grounds for protest including appropriate support exhibits, and it shall specify the ruling requested from the Assistant Finance Director. The protest shall be delivered to the Assistant Finance Director.

CHANGED WORK

The County may from time-to-time order additions, deletions or revisions in the work; these will be authorized by a written change order prepared and signed by the County.

Additional work performed without authorization of a written and executed change order will not entitle bidder to an increase of contract price or an extension of contract time.

If notice of a change affecting the general scope of work or change in contract price is required by the provisions of any bond to be given to the surety, it will be the bidder's responsibility to notify the surety, and the amount of each applicable bond shall be adjusted accordingly.

QUESTIONS

Questions regarding the specifications stated within the bid or the bidding process should be directed to Troy Hall, Assistant Finance Director at thall@currycounty.org

GENERAL CONDITIONS

1. Bid Forms: All pages included in this Invitation to Bid that are marked "**BID FORM**" must be completed and returned as part of the bid document. All bids

**Curry County Administrative Complex
Bid No. 2020/21-09 5th Street Parking Lot Construction
Page 11 Commodity Class #91375 #91394**

must be completed and securely sealed prior to submitting to the purchasing office. No un-sealed, faxed or e-mailed bids are acceptable.

2. Bids Binding Ninety (90) days: Unless otherwise specified all formal bids submitted shall be binding for ninety (90) calendar days following bid opening date, unless the bidder(s), upon request of the County Manager, agrees to an extension.
3. Payment Terms: For all goods/services provided by bidder, payment shall be made net thirty (30) days from invoice date after receipt of goods/services unless otherwise specified on bid form or as otherwise agreed by both parties. All invoices shall be submitted directly to the Curry County Finance Department at 417 Gidding, Suite 100, Clovis, NM 88101. The successful bidder must submit and have a completed W9 form on file with the County prior to any payments being issued.

For all services paid by Credit Card, standard payments are usually made within 3-5 business days. All services made by credit card require a receipt. Invoices shall not be submitted separately if payment is made with credit card. Curry County shall not pay any fees when utilizing a credit card for payment.

4. Equivalency: The County hereby reserves the right to approve as equivalent, or to reject as not being equivalent, any item the bidder proposes to furnish which contains variations from specification requirements but may comply substantially therewith. Such decisions are strictly at the discretion of the County.
5. If there is any clarification, problem, ambiguity or question regarding this bid, you must contact the Assistant Finance Director or designee prior to the bid opening. Clarifications and addenda will be considered prior to the bid opening. Answers provided regarding the bid specifications or bid package MUST be answered by the Assistant Finance Director or designee. Questions answered by any other person or County official shall be considered completely non-applicable to the legal provisions of this bid, except as specifically authorized by the Assistant Finance Director. Every request for interpretation shall be made in writing to the Assistant Finance Director. Any inquiry received ten (10) or more days prior to the date fixed for opening of Bids will be given consideration. Every interpretation made to a bidder will be in the form of an Addendum to the Invitation to Bid, and when issued, will be on file at the County and in the office of the Engineer at least two (2) days before bid closing. In addition, all Addenda will be mailed to each person holding Contract Documents, but it shall be the bidder's responsibility to make inquiry as to any Addenda issued. All such Addenda shall become part of the Contract and all bidders shall be bound by such Addenda.
6. Restrictive Specifications: It is the responsibility of the prospective bidder to review the entire Invitation to Bid (ITB) packet and to notify the purchasing department if the specifications are formulated in a manner which would unnecessarily restrict competition. Any such protest or question regarding the

**Curry County Administrative Complex
Bid No. 2020/21-09 5th Street Parking Lot Construction
Page 12 Commodity Class #91375 #91394**

specifications or bidding procedures must be received in the purchasing department not less than seventy-two (72) hours prior to the time set for bid opening.

7. An in-state resident or resident veteran preference will be given to all resident New Mexico businesses that have been issued certification by the State of New Mexico. To qualify for the preference, the bidder must list a valid resident business certificate number and shall submit a copy of the certificate with the bid. If you have a question regarding a Resident Business (or Resident Veteran Business) Certification, or wish to be given a number, you may contact the New Mexico State Department of Taxation and Revenue at 505-827-0951. This number is valuable to have as it allows the county to consider your bid at five to ten percent less than the amount submitted, and could mean a difference in award. Please note that this number is NOT your State CRS Number (i.e. 01-503047-004). In addition, **any preference numbers issued by the NM State Purchasing Office were valid only through December 31, 2011 and must be re-issued through the Taxation and Revenue Department.**
8. Bidders shall list on a separate sheet of paper any variations from or exceptions to the conditions and specifications of this bid. **This sheet shall be labeled "Exception(s) to Bid Conditions" and shall be included with bid.**
9. Non-collusion: Bidders, by submitting a signed bid, certify that the accompanying bid or proposal is not the result of, or affected by, any unlawful act of collusion with any other person or company engaged in the same line of business or commerce, or any other fraudulent act punishable under New Mexico or United States law.
10. Non-discrimination Statement: Curry County in accordance with the provisions of Title VI of the Civil Rights Act of 1964 (78 Stat. 252, 42 U.S.C. §§ 2000d to 2000d-4) and the Regulations, hereby notifies all bidders that it will affirmatively ensure that any contract entered into pursuant to this advertisement, disadvantaged business enterprises will be afforded full and fair opportunity to submit bids in response to this invitation and will not be discriminated against on the grounds of race, color, or national origin in consideration for an award. Please refer to complete Curry County Title VI Plan, specifically Appendices A and E at <http://www.currycounty.org/dr/miscellaneous>.
11. Qualifications of Bidders: The County Purchasing Officer may make such investigations as he/she deems necessary to determine the ability of the bidder to perform the work, and the bidder shall furnish to the County all such information and data for this purpose as the County may request. The County reserves the right to reject any bid if the evidence submitted by, or investigation of, such bidder fails to satisfy the County that such bidder is properly qualified to carry out the obligations of the contract and to complete the work contemplated therein.

**Curry County Administrative Complex
Bid No. 2020/21-09 5th Street Parking Lot Construction
Page 13 Commodity Class #91375 #91394**

12. The State of New Mexico's Procurement Code, Section 13-1-28 through Section 13-1-199 NMSA 1978, imposes civil and criminal penalties for its violations. In addition, the New Mexico Criminal Statutes impose felony penalties for illegal bribes, gratuities and kickbacks.
13. Curry County reserves the right to reject any bid from a bidder who previously failed to perform properly, or complete on time, contracts of similar nature, or to reject the bid of a bidder who is not in a position to perform such a contract satisfactorily. Such is at the discretion of the County.
14. The successful bidder agrees to protect, defend and save the County, its elected and appointed officials, agents, and employees, while acting within the scope of their duties as such, harmless from and against all claims, demands, causes of action of any kind or character, including the cost of defense thereof, arising in favor of the contractor's employees or third parties on account of bodily or personal injuries, death, or damage to property arising out of services performed or omissions of services or in any way resulting from the acts or omissions of the contractor and/or its agents, employees, representatives, assigns, subcontractors, except the sole negligence of the County under this agreement.
15. If a bidder to whom a bid is awarded refuses to accept the award or, fails to deliver in accordance with the contract terms and conditions, the County may, in its discretion, suspend the bidder/contractor for a period of time from entering into any contracts with Curry County.
16. This solicitation is governed by the laws of the State of New Mexico. By signing and submitting a bid, the parties agree that any litigation concerning this bid, request for proposal, limited solicitation, or subsequent contract or purchase order, must be brought in the Ninth Judicial District in and for Curry County, State of New Mexico, and each party shall pay its own costs and attorney fees.
17. Successful bidder must, in performance of work, agree to fully comply with all applicable federal, state and local laws, rules and regulations. The bidder will be required to carry the following minimum insurance coverage with Curry County named as additional insured on all policies:
 - a. General and professional liability insurance in the amount of \$1,050,000 single limit, and \$2,000,000 aggregate
 - b. Workers' Compensations insurance as required by state statute.
18. It is the responsibility of the bidder to ensure that any addenda issued related to this Invitation to Bid have been received prior to submitting a bid. The County guarantees that any addenda issued will be distributed and available to every party on the Distribution List for this solicitation. The County will not accept responsibility for addenda not being obtained, and will not guarantee that addenda will be forwarded or available if the original packet was not obtained as directed.

**Curry County Administrative Complex
Bid No. 2020/21-09 5th Street Parking Lot Construction
Page 14 Commodity Class #91375 #91394**

19. Bidder shall comply with the provisions of the Americans Disabilities Act of 1990.

**BID FORM 1
 STREET CONSTRUCTION BID ITEMS
 INVITATION TO BID # 2020/21-09**

ITEM NO.	DESCRIPTION	APPROX. QUANTITY	UNIT BID PRICES	AMOUNT BID
1.	UNCLASSIFIED EXCAVATION AT _____ L.S.	1.0		
2.	SUBGRADE PREPARATION AT _____ S.Y.	1151.0		
3.	BASE COURSE – 6” DEPTH AT _____ S.Y.	1091.0		
4.	HOT MIX ASPHALT PAVEMENT-2” AT _____ S.Y.	1091.0		
5.	BITAMINOUS MATERIAL FOR PRIME COAT AT _____ TON	1.2		
6.	REMOVAL OF STRUCTURES & OBSTRUCTIONS AT _____ L.S.	1.0		
7.	CONCRETE CURB & GUTTER (6” x 24”) AT _____ L.F.	230.0		
8.	CONCRETE VALLEY GUTTER (8” X 24”) AT _____ L.F.	160.0		
9.	CONCRETE PAVEMENT-6” AT _____ S.Y.	60.0		
10.	CONCRETE FILLET, CURB, HANDICAP RAMP AND LANDING WITH DETECTABLE WARNING SURFACE AT _____ E.A.	1.0		

Curry County Administrative Complex
 Bid No. 2020/21-09 5th Street Parking Lot Construction
 Page 16 Commodity Class #91375 #91394

11.	CONCRETE PARKING BLOCKS AT _____ E.A.	20.0		
12.	TRAFFIC CONTROL PLAN AT _____ L.S.	1.0		
13.	REFELCTORIZED PAINTED STRIPING- 4" AT _____ L.F.	850.0		
14.	REFLECTORIZED PLASTIC PAVEMENT MARKING "ENTER" AT _____ E.A.	1.0		
15.	REFLECTORIZED PLASTIC PAVEMENT MARKINGS "EXIT" AT _____ E.A.	1.0		
16.	RELECTORIZED MARKING "ONLY" AT _____ E.A.	2.0		
17.	REFLECTORIZED PLASTIC PAVEMENT ARROW (THRU) AT _____ E.A.	2.0		
18.	KAX LED SIZE 2 PARKING LOT LIGHT POLE AND BASE WITH LUMINAIRE (1 HEAD) AT _____ E.A.	4.0		
19.	ELECTRIC JUNCTION BOX (12" x 12") AT _____ E.A.	4.0		
20.	3/4" ELECTRICAL CONDUIT LINE WITH 1- #10 BLACK, 1-#10 WHITE AND 1-#10 GREEN WIRE (IN-PLACE) AT _____ L.F.	285.0		
21.	ELECTRICAL UNISTRIL STAND WITH METER PANEL AND TIME CLOCK AT _____ L.S.	1.0		
22.	ELECTRICAL SERVICE POLE AND METER WITH CONNECTION TO X-CEL ENERGY POLE AT _____ L.S.	1.0		
23.	1-1/2" PVC CONDUIT IRRIGATION LINE SLEEVE AT _____ L.S.	1.0		

Curry County Administrative Complex
 Bid No. 2020/21-09 5th Street Parking Lot Construction
 Page 17 Commodity Class #91375 #91394

24.	1" SCHEDULE 40 PVC DRIP IRRIGATION LINE + NETFIM DRIP AT _____ L.S.	1.0		
25.	RED YUCCA – 5 GAL AT _____ L.S.	3.0		
26.	PURPLE PLUM (2" CALIPER) AT _____ E.A.	4.0		
27.	CHINESE PISTASHA OF CLEVELAND PEAR (2" CALIPER) AT _____ E.A.	2.0		
28.	MOSS BUILDER (2x2x3) AT _____ E.A.	6.0		
29.	PUEBLO ROSE FINES (IN-PLACE) AT _____ S.Y.	135.0		
30.	HOSE BIB, SHUT-OFF VALVE, BACKFLOW PREVENTER AND CONNECTION AT _____ E.A.	1.0		
31.	1" DRIP VALVE AND 1" Y FITTER / 30 PSI AT _____ E.A.	1.0		
32.	RAINBIRD RSP-6 STATION CONTROLLER AT _____ E.A.	1.0		
33.	CONSTRUCTION STAKING BY CONTRACTOR AT _____ L.S.	1.0		
34.	MOBILIZATION AT _____ L.S.	1.0		
SUBTOTAL:\$				
TAX: (8.1875%) \$				
TOTAL CONSTRUCTION COST: \$				

BID FORM 1
STREET CONSTRUCTION BID ITEMS
INVITATION TO BID # 2020/21-09

Signed _____

Printed/typewritten name _____

Title _____

Firm _____

Contractor License# _____

Address _____

Phone _____ Fax _____

Email _____ Date _____

BID FORM 2
SUBCONTRACTOR LISTING
INVITATION TO BID # 2020/21-09

The Subcontractor Listing Threshold for this Project is \$5,000, and Attached to the Bid in Compliance with 13-4-32 thru 13-4-43 NMSA 1978, Together with the City or County location of their place of business listed. The following subcontractors will work on the construction of the project if the bid is accepted. List only one entry for each category of work as defined by Contractor. Bidder represents that it is licensed and qualified to Perform 100% of the category of work for which no subcontractor is listed. D.W.S Registration Number required if amount of work exceed \$60,000.

Company Name: _____
Address: _____
City/County: _____ State: ____
Work to be performed: _____
Amount (\$): _____
License No.: _____
DWS Registration No. _____

Company Name: _____
Address: _____
City/County: _____ State: ____
Work to be performed: _____
Amount (\$): _____
License No.: _____
DWS Registration No. _____

Company Name: _____
Address: _____
City/County: _____ State: ____
Work to be performed: _____
Amount (\$): _____
License No.: _____
DWS Registration No. _____

Company Name: _____
Address: _____
City/County: _____ State: ____
Work to be performed: _____
Amount (\$): _____
License No.: _____
DWS Registration No. _____

Company Name: _____
Address: _____
City/County: _____ State: ____
Work to be performed: _____
Amount (\$): _____
License No.: _____
DWS Registration No. _____

Company Name: _____
Address: _____
City/County: _____ State: ____
Work to be performed: _____
Amount (\$): _____
License No.: _____
DWS Registration No. _____

Company Name: _____
Address: _____
City/County: _____ State: ____
Work to be performed: _____
Amount (\$): _____
License No.: _____
DWS Registration No. _____

Company Name: _____
Address: _____
City/County: _____ State: ____
Work to be performed: _____
Amount (\$): _____
License No.: _____
DWS Registration No. _____

**Curry County Administrative Complex
Bid No. 2020/21-09 5th Street Parking Lot Construction
Page 20 Commodity Class #91375 #91394**

-No bidder whose bid is accepted shall permit any subcontract to be voluntarily assigned or transferred or allow it to be performed by anyone other than the original subcontractor listed in the original bid without the consent of the County.

-No bidder whose bid is accepted, other than in the performance of change orders causing changes or deviations from the original contract, shall sublet or subcontract any portion of the work in excess of the listing threshold as to which the original bid did not designate a subcontract unless:

(1) the bidder fails to receive a bid from a category of work. Under such circumstances, the bidder may subcontract. The bidder shall designate on the listing form that no proposal was received or;

(2) the bidder fails to receive more than one bid for a category of work. Under such circumstances, the bidder may subcontract. The bidder shall state on the listing form that only one subcontractor's proposal was received, together with the name of the subcontractor. This designation shall not occur more than one time on the subcontractor list.

(Signature of Business Representative)*

(Date)

*Must be an authorized signatory for the Business.

BID FORM 3
CAMPAIGN CONTRIBUTION DISCLOSURE FORM

Pursuant to the Procurement Code, Sections 13-1-28, et seq., NMSA 1978 and NMSA 1978, § 13-1-191.1 (2006), as amended by Laws of 2007, Chapter 234, any prospective contractor seeking to enter into a contract with any state agency or local public body **for professional services, a design and build project delivery system, or the design and installation of measures the primary purpose of which is to conserve natural resources** must file this form with that state agency or local public body. This form must be filed even if the contract qualifies as a small purchase or a sole source contract. The prospective contractor must disclose whether they, a family member or a representative of the prospective contractor has made a campaign contribution to an applicable public official of the state or a local public body during the two years prior to the date on which the contractor submits a proposal or, in the case of a sole source or small purchase contract, the two years prior to the date the contractor signs the contract, if the aggregate total of contributions given by the prospective contractor, a family member or a representative of the prospective contractor to the public official exceeds two hundred and fifty dollars (\$250) over the two year period.

Furthermore, the state agency or local public body may cancel a solicitation or proposed award for a proposed contract pursuant to Section 13-1-181 NMSA 1978 or a contract that is executed may be ratified or terminated pursuant to Section 13-1-182 NMSA 1978 of the Procurement Code if: 1) a prospective contractor, a family member of the prospective contractor, or a representative of the prospective contractor gives a campaign contribution or other thing of value to an applicable public official or the applicable public official's employees during the pendency of the procurement process or 2) a prospective contractor fails to submit a fully completed disclosure statement pursuant to the law.

The state agency or local public body that procures the services or items of tangible personal property shall indicate on the form the name or names of every applicable public official, if any, for which disclosure is required by a prospective contractor.

THIS FORM MUST BE INCLUDED IN THE REQUEST FOR PROPOSALS AND MUST BE FILED BY ANY PROSPECTIVE CONTRACTOR WHETHER OR NOT THEY, THEIR FAMILY MEMBER, OR THEIR REPRESENTATIVE HAS MADE ANY CONTRIBUTIONS SUBJECT TO DISCLOSURE.

The following definitions apply:

“Applicable public official” means a person elected to an office or a person appointed to complete a term of an elected office, who has the authority to award or influence the award of the contract for which the prospective contractor is submitting a competitive sealed proposal or who has the authority to negotiate a sole source or small purchase contract that may be awarded without submission of a sealed competitive proposal.

“Campaign Contribution” means a gift, subscription, loan, advance or deposit of money or other thing of value, including the estimated value of an in-kind contribution,

**Curry County Administrative Complex
Bid No. 2020/21-09 5th Street Parking Lot Construction
Page 22 Commodity Class #91375 #91394**

that is made to or received by an applicable public official or any person authorized to raise, collect or expend contributions on that official's behalf for the purpose of electing the official to statewide or local office. "Campaign Contribution" includes the payment of a debt incurred in an election campaign, but does not include the value of services provided without compensation or unreimbursed travel or other personal expenses of individuals who volunteer a portion or all of their time on behalf of a candidate or political committee, nor does it include the administrative or solicitation expenses of a political committee that are paid by an organization that sponsors the committee.

"Family member" means spouse, father, mother, child, father-in-law, mother-in-law, daughter-in-law or son-in-law of (a) a prospective contractor, if the prospective contractor is a natural person; or (b) an owner of a prospective contractor.

"Pendency of the procurement process" means the time period commencing with the public notice of the request for proposals and ending with the award of the contract or the cancellation of the request for proposals.

"Prospective contractor" means a person or business that is subject to the competitive sealed proposal process set forth in the Procurement Code or is not required to submit a competitive sealed proposal because that person or business qualifies for a sole source or a small purchase contract.

"Representative of a prospective contractor" means an officer or director of a corporation, a member or manager of a limited liability corporation, a partner of a partnership or a trustee of a trust of the prospective contractor.

Name(s) of Applicable Public Official(s) if any: James Ridling, Robert Sandoval, Chet Spear, Robert Thornton, Seth Martin Anastasia Hogland, Candace Morrison, Kendall Kempf, Wesley Waller, Mark Lansford

DISCLOSURE OF CONTRIBUTIONS BY PROSPECTIVE CONTRACTOR:

Contribution Made By: _____

Relation to Prospective Contractor: _____

Date Contribution(s) Made: _____

Amount(s) of Contribution(s) _____

Nature of Contribution(s) _____

Purpose of Contribution(s) _____

(Attach extra pages if necessary)

**Curry County Administrative Complex
Bid No. 2020/21-09 5th Street Parking Lot Construction
Page 23 Commodity Class #91375 #91394**

Signature

Date

Title (position)

--OR--

NO CONTRIBUTIONS IN THE AGGREGATE TOTAL OVER TWO HUNDRED FIFTY DOLLARS (\$250) WERE MADE to an applicable public official by me, a family member or representative.

Signature

Date

Title (Position)

**BID FORM #4
RESIDENT/VETERANS PREFERENCE CERTIFICATION FORM**

_____ (NAME OF CONTRACTOR) hereby certifies the following in regard to application of the resident veterans' preference to this procurement:

Please check one box only

Resident Veterans:

I declare under penalty of perjury that my business prior year revenue starting January 1 ending December 31 is less than \$3M allowing me the 10% preference discount on this bid or proposal. I understand that knowingly giving false or misleading information about this fact constitutes a crime

Resident Businesses:

I declare under penalty of perjury that my business is a New Mexico resident business allowing me the 5% preference discount on this bid or proposal. I understand that knowingly giving false or misleading information about this fact constitutes a crime.

"I agree to submit a report, or reports, to the State Purchasing Division of the General Services Department declaring under penalty of perjury that during the last calendar year starting January 1 and ending on December 31, the following to be true and accurate:

"In conjunction with this procurement and the requirements of this business' application for a Resident Veteran Business Preference/Resident Veteran Contractor Preference under Sections 13-1-21 or 13-1-22 NMSA 1978, when awarded a contract which was on the basis of having such veterans preference, I agree to report to the State's Division of the General Services Department the awarded amount involved. I will indicate in the report the awarded amount as a purchase from a public body or as a public works contract from a public body as the case may be.

"I understand that knowingly giving false or misleading information on this report constitutes a crime."

I declare under penalty of perjury that this statement is true to the best of my knowledge. I understand that giving false or misleading statements about material fact regarding this matter constitutes a crime.

Resident Business/Veteran Business Certificate Number: _____

The representations made in checking the boxes constitutes a material representation by the business that is subject to protect and may result in denial of an award or un-award of the procurement involved if the statements are proven to be incorrect.

A valid New Mexico Resident Business or New Mexico Veteran's Resident Business Certificate number must be provided in order to receive preference.

I do not claim New Mexico Resident Business or New Mexico Veteran's Resident Business preference on this bid.

(Signature of Business Representative)*

(Date)

*Must be an authorized signatory for the Business.



TYPE "A" - STREET, HIGHWAY, UTILITY & LIGHT ENGINEERING

Effective January 1, 2021

Trade Classification	Base Rate	Fringe Rate
Bricklayer/Block layer/Stonemason	24.46	8.81
Carpenter/Lather	25.63	11.74
Carpenter- Los Alamos County	28.37	13.44
Cement Mason	17.42	6.81
Ironworker	27.35	17.49
Painter- Commercial	17.25	7.75
Plumber/Pipefitter	31.52	12.90
Electricians- Outside Classifications: Zone 1		
Ground man	23.74	13.16
Equipment Operator	34.06	15.94
Lineman/ Technician	40.07	17.57
Cable Splicer	44.08	18.65
Electricians-Outside Classifications: Zone 2		
Ground man	23.74	13.16
Equipment Operator	34.06	15.94
Lineman/ Technician	40.07	17.57
Cable Splicer	44.08	18.65
Electricians-Outside Classifications: Los Alamos		
Ground man	24.42	13.34
Equipment Operator	35.04	16.21
Lineman/ Technician	41.22	17.88
Cable Splicer	45.34	18.99
Laborers		
Group I- Unskilled	12.26	6.22
Group II- Semi-Skilled	12.56	6.22
Group III- Skilled	12.96	6.22
Group IV- Specialty	13.21	6.22
Operators		



Group I	19.15	6.54
Group II	20.11	6.54
Group III	20.21	6.54
Group IV	20.33	6.54
Group V	20.43	6.54
Group VI	20.62	6.54
Group VII	20.78	6.54
Group VIII	21.08	6.54
Group IX	28.80	6.54
Group X	32.15	6.54
Truck Drivers		
Group I-IX	16.67	8.27

NOTE: All contractors are required to pay **SUBSISTENCE, ZONE AND INCENTIVE PAY** according to the particular trade. Details are located in a PDF attachment at WWW.DWS.STATE.NM.US. Search Labor Relations/Labor Information/Public Works/Prevailing Wage Rates.

For more information about the Subsistence, Zone, and Incentive Pay rates, or to file a wage claim, contact the Labor Relations Division at (505) 841-4400 or visit us online at www.dws.state.nm.us.

PUBLIC WORKS PROJECT REQUIREMENTS

As a participant in a Public Works project valued at more than \$60,000 in the state of New Mexico, the following list addresses many of the responsibilities that are defined by statute or regulation to each project stakeholder.

Contracting Agency

- Ensure that all contractors wishing to bid on a Public Works project when the project is \$60,000 or more are actively registered with the Public Works and Apprenticeship Application (PWAA) website: <http://www.dws.state.nm.us/pwaa> (Contractor Registration) prior to bidding.
- Please submit Notice of Award (NOA) and Subcontractor List(s) to the PWAA website promptly after the project is awarded.
- Please update the Subcontractor List(s) on the PWAA website whenever changes occur.
- All sub-contractors and tiers (excluding professional services) regardless of contract amount must be listed on the Subcontractor List and must adhere to the Public Works Minimum Wage Act.
- Ninety days after project completion please go into the PWAA system and close the project. Only contracting agencies are allowed to close the project. Agents or contractors are not allowed to close projects.

General Contractor

- Provide a complete Subcontractor List and Statements of Intent (SOI) to Pay Prevailing Wages for all contractors, regardless of amount of work, to the contracting agency within 3 (three) days of award.
- Ensure that all subcontractors wishing to bid on a Public Works project have an active Contractor Registration with the Public Works and Apprenticeship Application (PWAA) website: <http://www.dws.state.nm.us/pwaa> prior to bidding when their bid will exceed \$60,000.
- Make certain the Public Works Apprentice and Training Act contributions are paid either to an approved Apprenticeship Program or to the Public Works Apprentice and Training Fund.
- Confirm the Wage Rate poster, provided in PWAA, is displayed at the job site in an easily accessible place.
- When the project has been completed, make sure the Affidavits of Wages Paid (AWP) are sent to the contracting agency.
- All subcontractors and tiers (excluding professional services) regardless of contract amount must pay prevailing wages, be listed on the Subcontractor List, and adhere to the Public Works Minimum Wage Act.



LABOR RELATIONS DIVISION
121 Tijeras Ave NE, Suite 3000
Albuquerque, NM 87102
Phone: 505-841-4400
Fax: 505-841-4424

WWW.DWS.STATE.NM.US

Subcontractor

- Ensure that all subcontractors wishing to bid on a Public Works project have an active Contractor Registration with the Public Works and Apprenticeship Application (PWAA) website: <http://www.dws.state.nm.us/pwaa> prior to bidding when their bid will exceed \$60,000.
- Make certain the Public Works Apprentice and Training Act contributions are paid either to an approved Apprenticeship Program or to the Public Works Apprentice and Training Fund.
- All subcontractors and tiers (excluding professional services) regardless of contract amount must pay prevailing wages, be listed on the Subcontractor List, and adhere to the Public Works Minimum Wage Act.

Additional Information

Reference material and forms may be found in the New Mexico Department of Workforce Solutions Public Works web pages at: <https://www.dws.state.nm.us/Labor-Relations/Labor-Information/Public-Works>.

CONTACT INFORMATION

Contact the Labor Relations Division for any questions relating to Public Works projects by email at public.works@state.nm.us or call (505) 841-4400.

City of Clovis
Curry County, New Mexico

MAY 2021

LOT 6 BLOCK 23 ORIGINAL TOWNSITE CORNER OF FIFTH STREET & GIDDING STREET CURRY COUNTY PROJECT # ITB-2020/21-09

DRAWING INDEX		
SEQUENCE NUMBER	SHEET NUMBER	SHEET TITLE
01	GI-000	COVER SHEET
02	V-101	EXISTING SITE SURVEY
03	CD-101	DEMOLITION PLAN
04	C-101	CONSTRUCTION PLAN
05	L-101	LANDSCAPE PLAN
06	ES-101	ELECTRICAL PLAN
07	C-501	CIVIL DETAILS

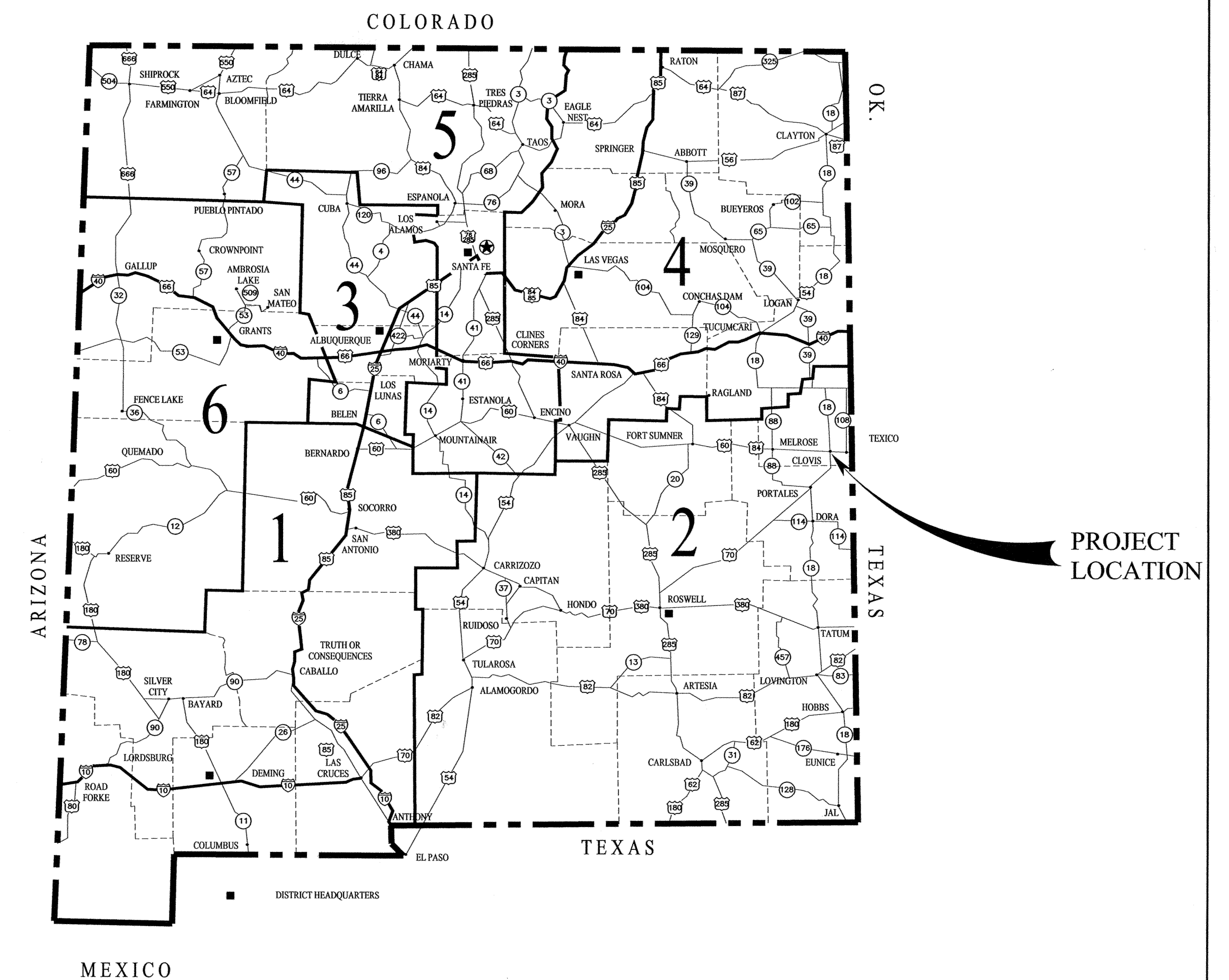

LYDICK
ENGINEERS & SURVEYORS
205 EAST SECOND STREET
CLOVIS, NEW MEXICO 88101
(575) 762-3771

Robert O. Sandoval
P.E. AND L.S. NO. 5955

04-21-21
DATE

CURRY COUNTY COMMISSION

- DISTRICT 1
ROBERT O. SANDOVAL
- DISTRICT 2
JAMES RIDLING
- DISTRICT 3
CHET SPEAR
- DISTRICT 4
SETH MARTIN
- DISTRICT 5
ROBERT THORNTON
- COUNTY MANAGER
LANCE PYLE

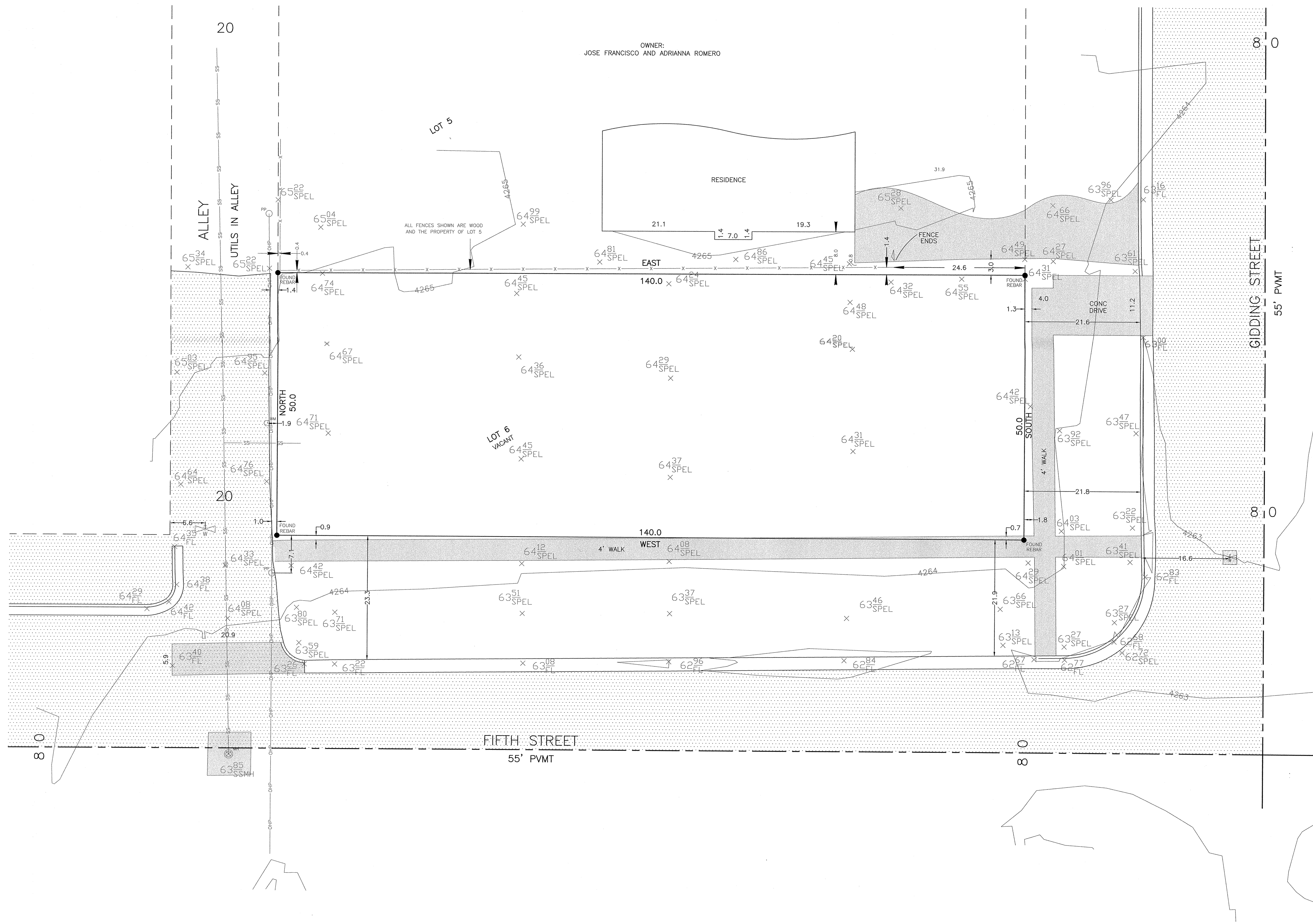

OWNER:
JOSE FRANCISCO AND ADRIANNA ROMERO

LOT 5

RESIDENCE

ALLEY
UTILS IN ALLEY

LOT 6
VACANT

GIDDING STREET
55' PVMT

FIFTH STREET
55' PVMT

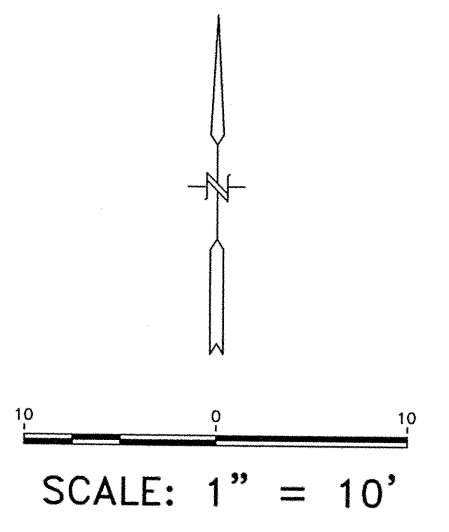

DESIGNED BY: RCL
DRAWN BY: DPL
SHEET CHECKED BY:
CROSS CHECKED BY:
APPROVED BY:
DATE: 03/28/2021

LYDICK
ENGINEERS & SURVEYORS
205 E. SECOND STREET, CLOVIS, NM 88101
PH: 575-762-3771, FAX: 575-762-9093

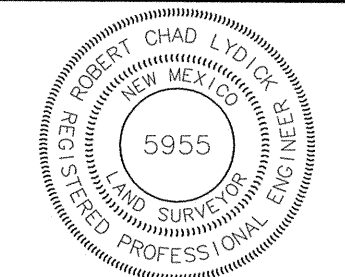

LOT 6 BLOCK 23
ORIGINAL TOWNSITE
CITY OF CLOVIS
CURRY COUNTY, NEW MEXICO

EXISTING SITE PLAN

PROJECT NO. 21992 B
FILE NAME: 21992 B.dwg
SHEET NO.
V-101

REV. NO.	DATE	DRWN	CHKD	REMARKS

DEMOLITION PLAN

- ① REMOVE 24.0 SQUARE YARDS OF CONCRETE DRIVEWAY AND 11.2 L.F. CONCRETE CURB & GUTTER
- ② REMOVE 72.5 SQUARE YARDS OF CONCRETE SIDEWALK
- ③ REMOVE 212.0 L.F. CONCRETE OF CURB & GUTTER
- ④ REMOVE 21.5 SQUARE YARDS OF CONCRETE SIDEWALK

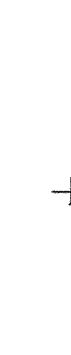
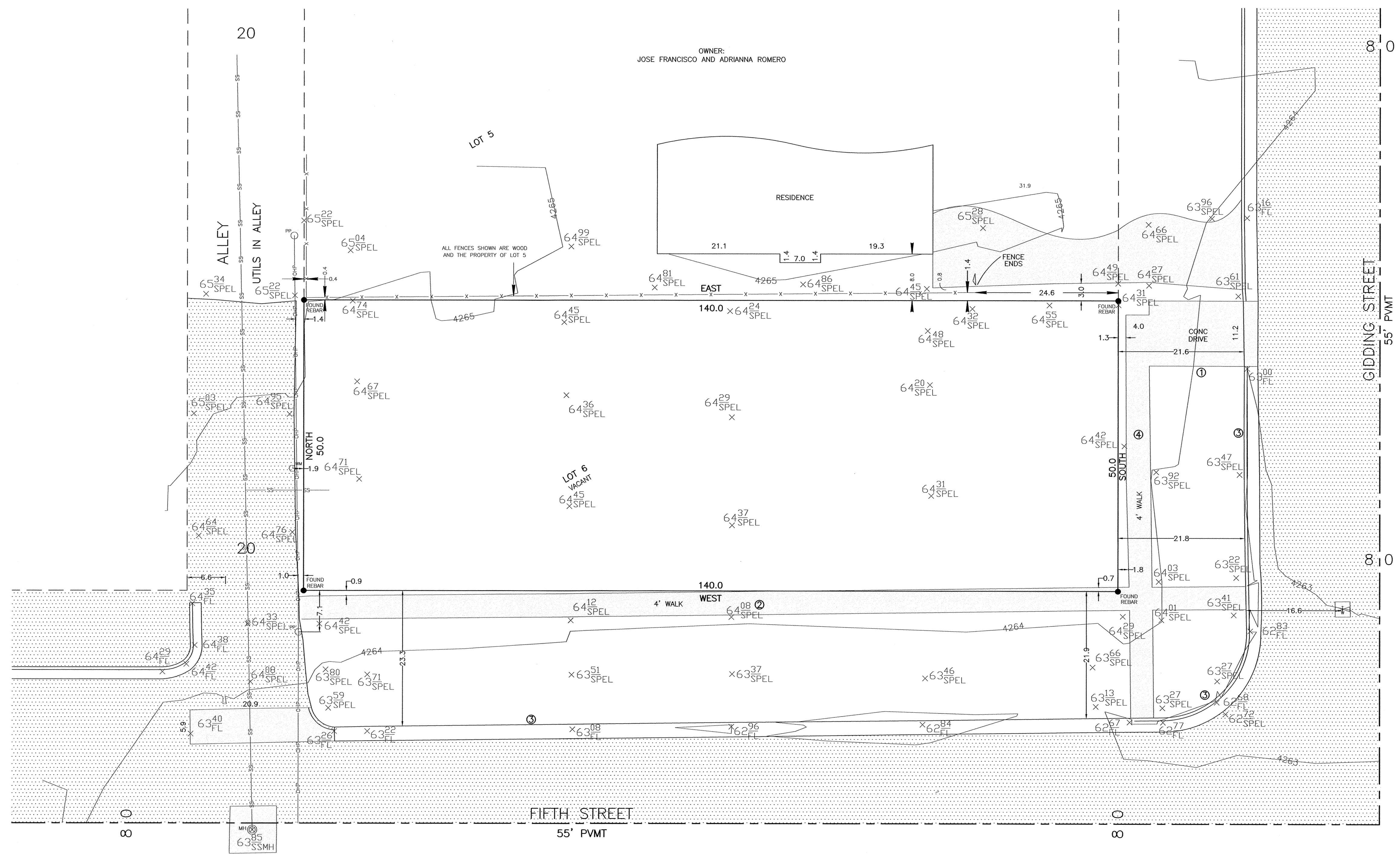

SCALE: 1" = 10'

REV. NO.	DATE	DRWN	CHKD	REMARKS

DESIGNED BY: RCL
 DRAWN BY: DL
 SHEET CHECK'D BY:
 CROSS CHECK'D BY:
 APPROVED BY:
 DATE: 04/29/2021

LYDICK
 ENGINEERS & SURVEYORS
 205 E. SECOND STREET, CLOVIS, NM 88101
 PH: 575-762-3771, FAX: 575-762-9093

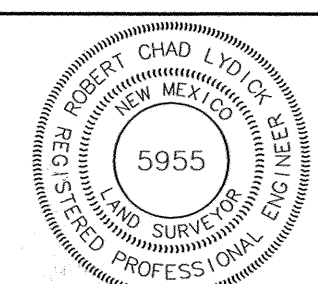

LOT 6 BLOCK 23
 ORIGINAL TOWNSITE
 CITY OF CLOVIS
 CURRY COUNTY, NEW MEXICO

DEMOLITION PLAN

PROJECT NO. 21992 B
 FILE NAME: 21992 B.dwg
 SHEET NO.
CD-101

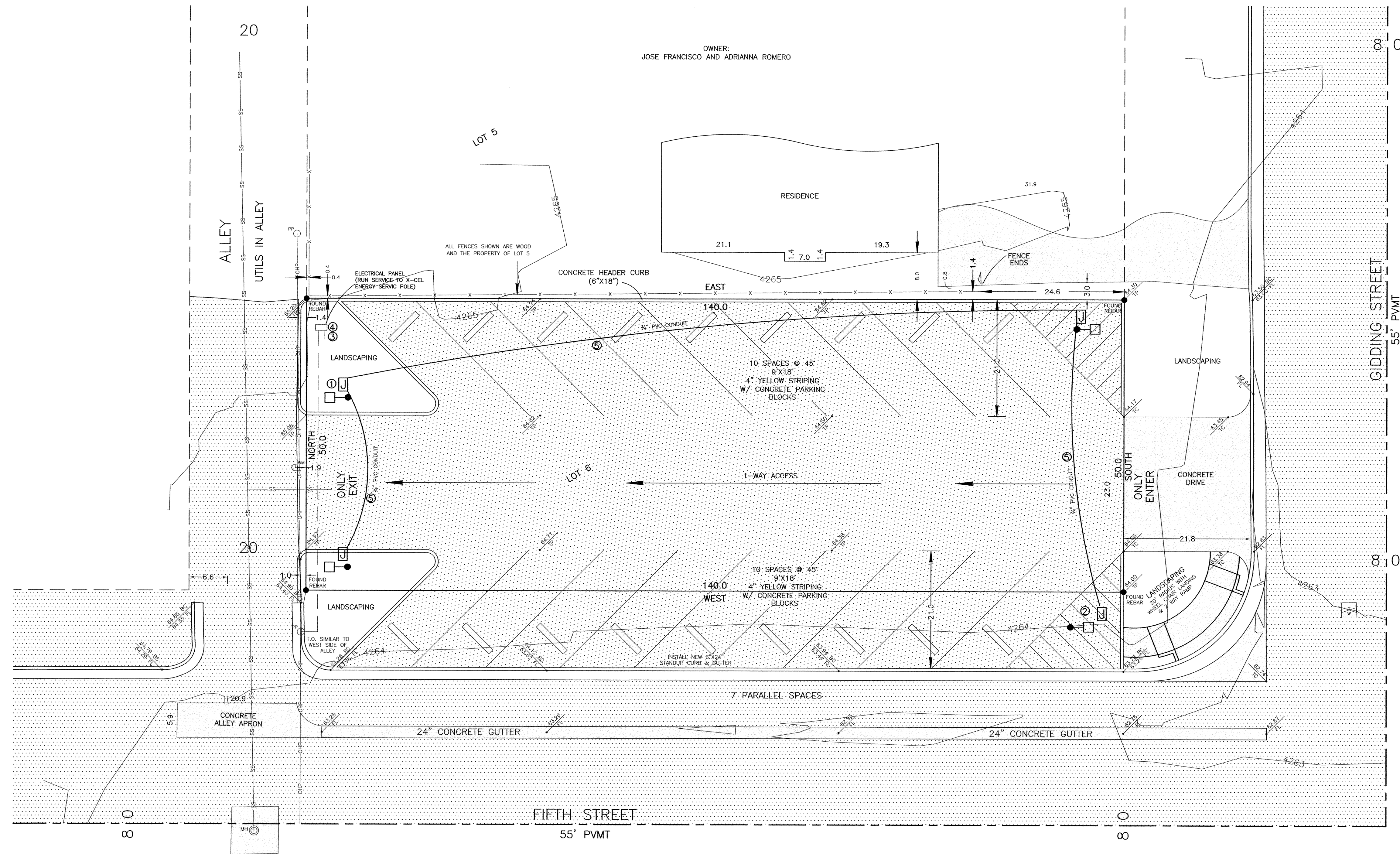

CONSTRUCTION NOTES			
ITEM #	DESCRIPTION	UNIT	QUANTITY
1	UNCLASSIFIED EXCAVATION	L.S.	1.0
2	SUBGRADE PREPARATION - 6"	S.Y.	1151.0
3	BASE COURSE	S.Y.	1091.0
4	HOT MIX ASPHALT PAVEMENT - 2"	S.Y.	1091.0
5	BITUMINOUS MATERIAL FOR PRIME COAT	TON	1.2
6	REMOVALS	L.S.	1.0
7	CONCRETE CURB & GUTTER	L.F.	230.0
8	CONCRETE CURB, FILLET, LANDING, AND ADA PEDESTRIAN RAMP (NMDOT SECTION DRAWING #608-001-S)	EA.	1.0
9	CONCRETE PAVEMENT - 6"	S.Y.	60.0
10	CONCRETE PARKING BLOCKS	EA.	18.0
11	CONCRETE HEADER CURB (6"x18")	L.F.	295.0
12	CONCRETE VALLEY GUTTER (8"x24")	L.F.	160.0
13	REFLECTORIZED PAINTED YELLOW STRIPING - 4"	L.F.	850.0
14	REFLECTORIZED PLASTIC PAVEMENT MARKING - "ENTER"	EA.	1.0
15	REFLECTORIZED PLASTIC PAVEMENT MARKING - "ONLY"	EA.	2.0
16	REFLECTORIZED PLASTIC PAVEMENT MARKING - "EXIT"	EA.	1.0
17	REFLECTORIZED PLASTIC PAVEMENT ARROW - "THRU"	EA.	2.0
18	LANDSCAPE PLAN (IN-PLACE)	L.S.	1.0

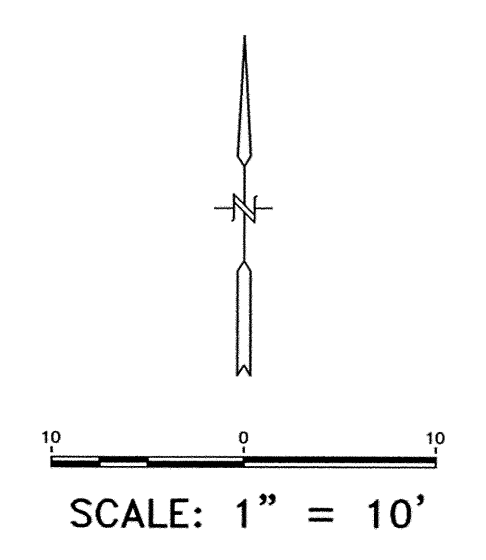

REV. NO.	DATE	DRWN	CHKD	REMARKS

DESIGNED BY:	RCL
DRAWN BY:	DPL
SHEET CHK'D BY:	
CROSS CHK'D BY:	
APPROVED BY:	
DATE:	04/20/2021

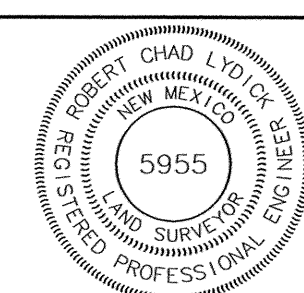
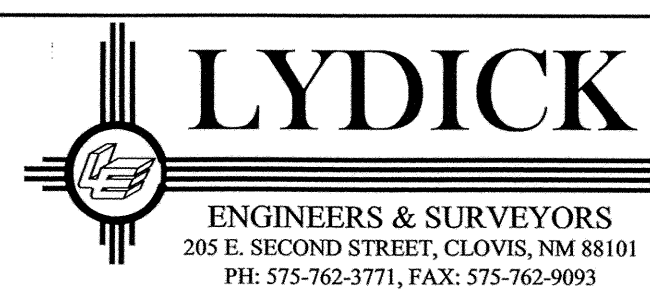

LOT 6 BLOCK 23
ORIGINAL TOWNSITE
CITY OF CLOVIS
CURRY COUNTY, NEW MEXICO

CONSTRUCTION PLAN



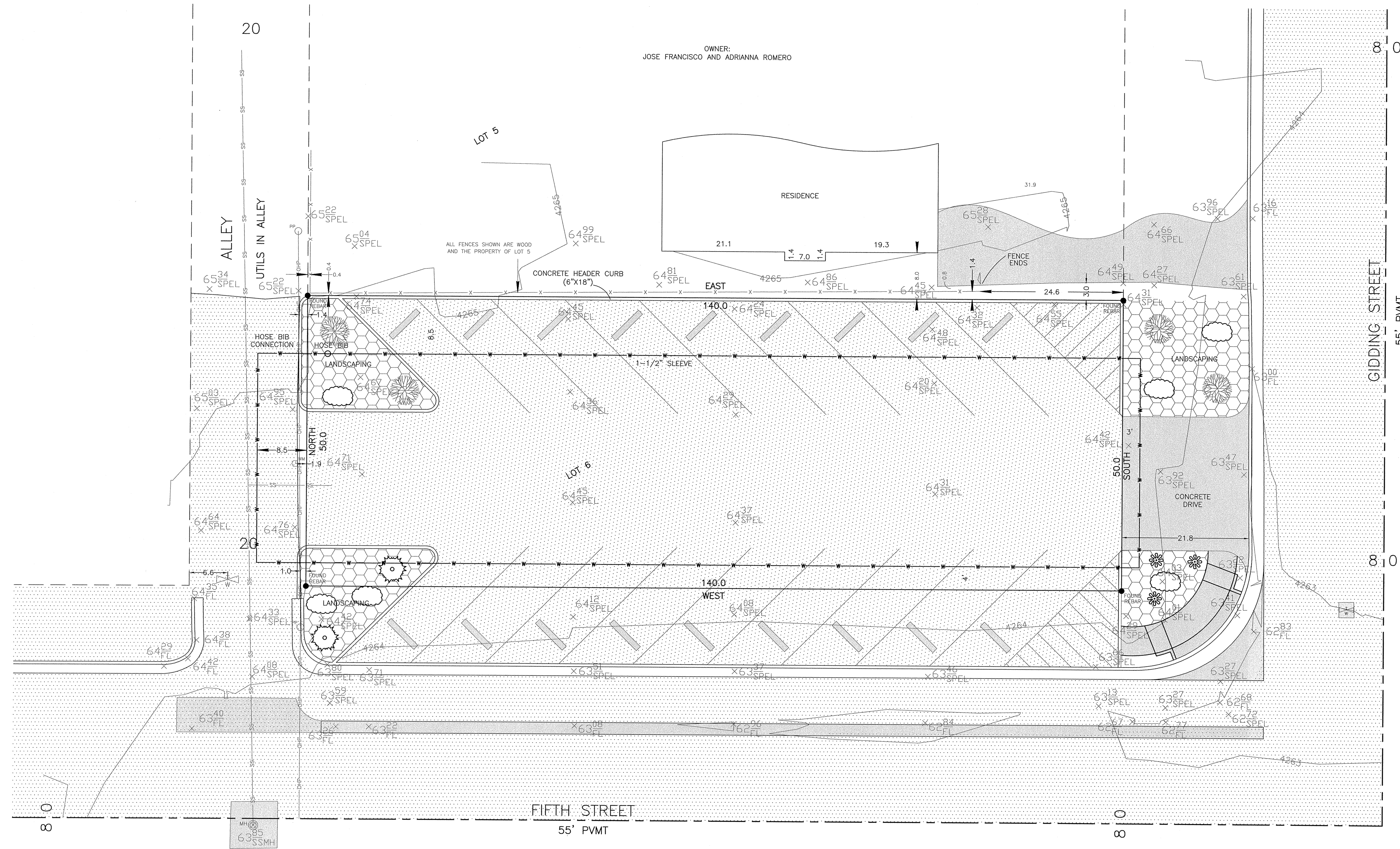

PROJECT NO. 21992 B
FILE NAME: 21992 B.dwg

SHEET NO.

C-101

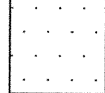

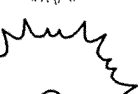
LEGEND

-  ASPHALT PAVEMENT
-  RED YUCCA (3)
-  PURPLE PLUM (4) (FRUITLESS)
2 IN CAL
-  CHINESE PISTASHA OR
CLEVELAND PEAR (2)
2 IN CAL, BRANCHES MUST BE
PRUNED 7' FROM BOTTOM BRANCH
INSTALL WITH SIDEWALK SHIELD (OR EQUAL)
-  2 X 2 X 3
MOSS BOULDER (6)
-  PUEBLO ROSE FINES

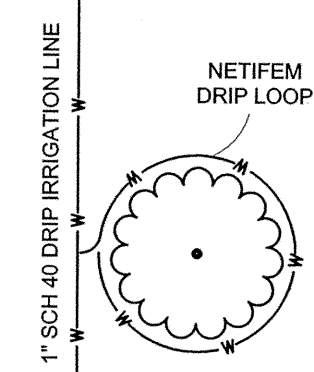

TYPICAL DETAIL FOR
DRIP LOOP AROUND
VEGETATION
SCALE: 1" = 10'

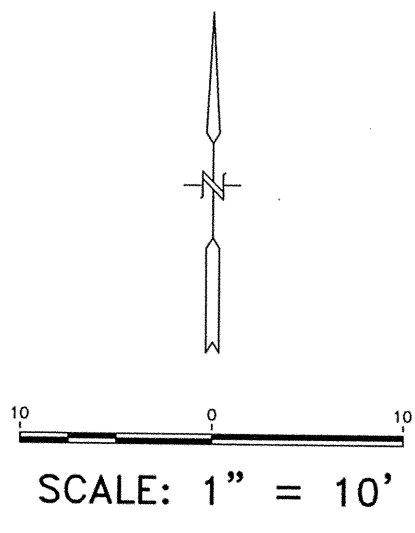

REV. NO.	DATE	DRWN	CHKD	REMARKS

DESIGNED BY: RCL
 DRAWN BY: DPL
 SHEET CHK'D BY: _____
 CROSS CHK'D BY: _____
 APPROVED BY: _____
 DATE: 04/12/2021

LYDICK
 ENGINEERS & SURVEYORS
 205 E. SECOND STREET, CLOVIS, NM 88101
 PH: 575-762-3771, FAX: 575-762-9093

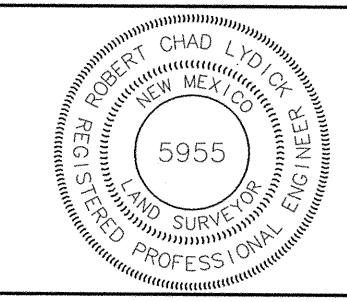

LOT 6 BLOCK 23
 ORIGINAL TOWNSITE
 CITY OF CLOVIS
 CURRY COUNTY, NEW MEXICO

LANDSCAPE PLAN

PROJECT NO. 21992 B
 FILE NAME: 21992 B.dwg
 SHEET NO.
L-101

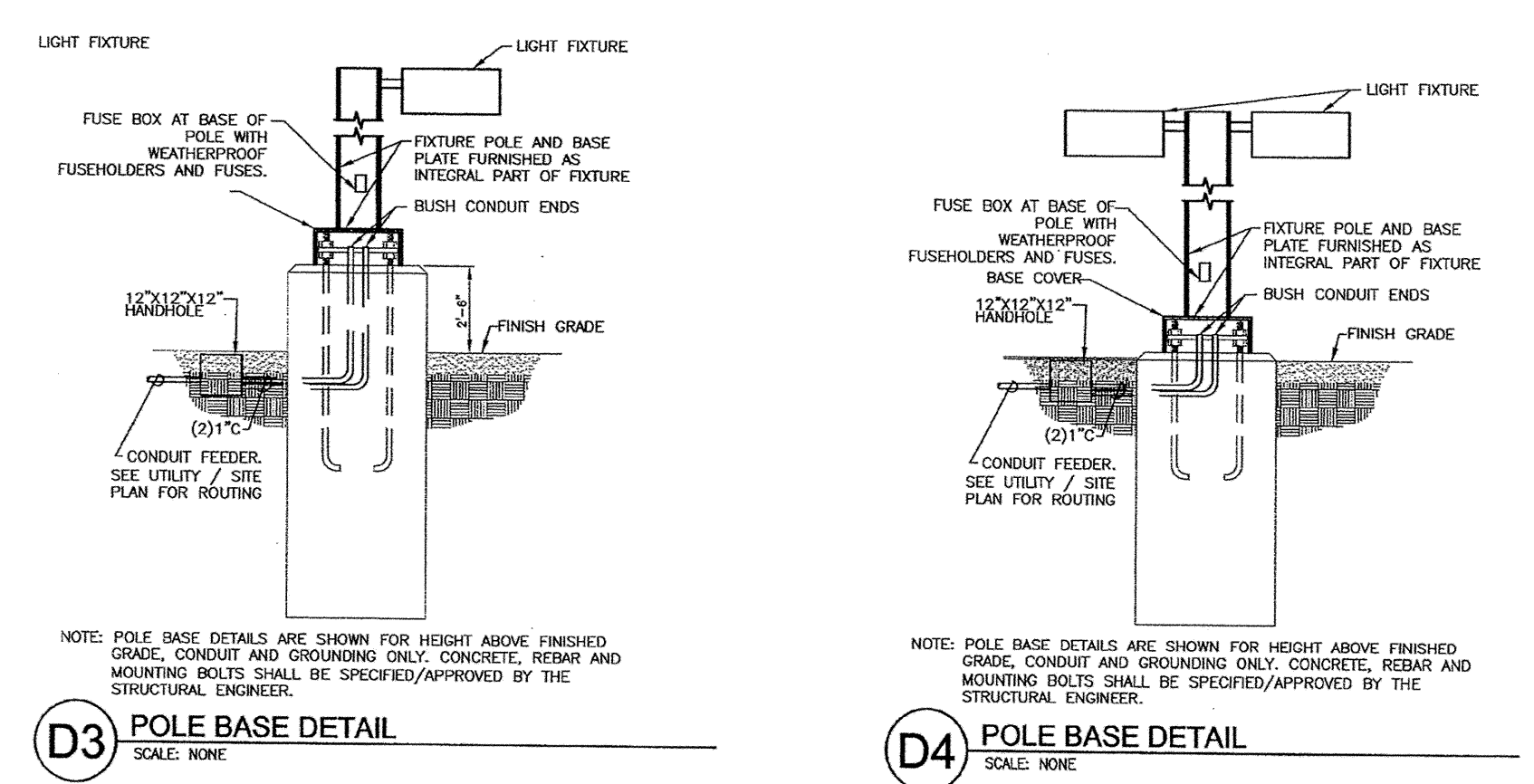
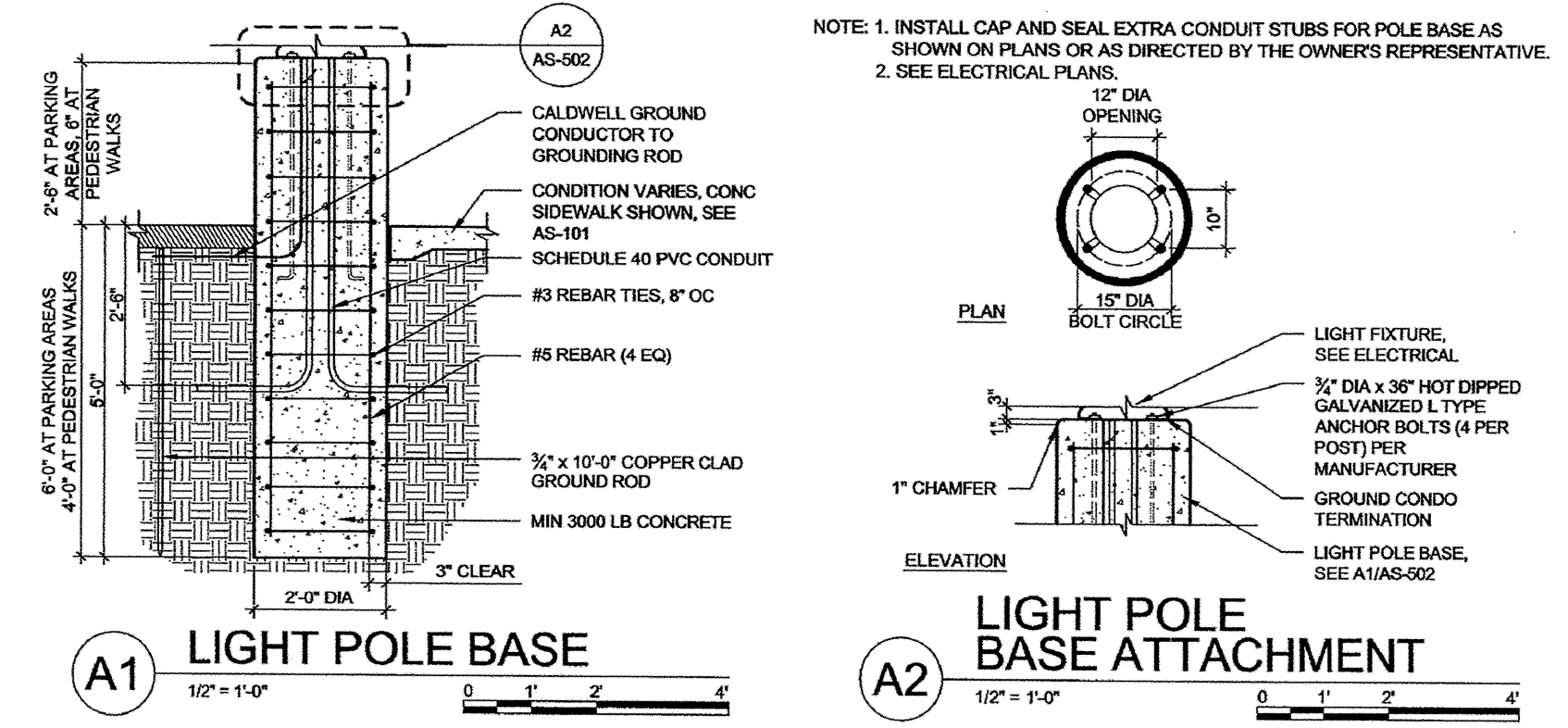
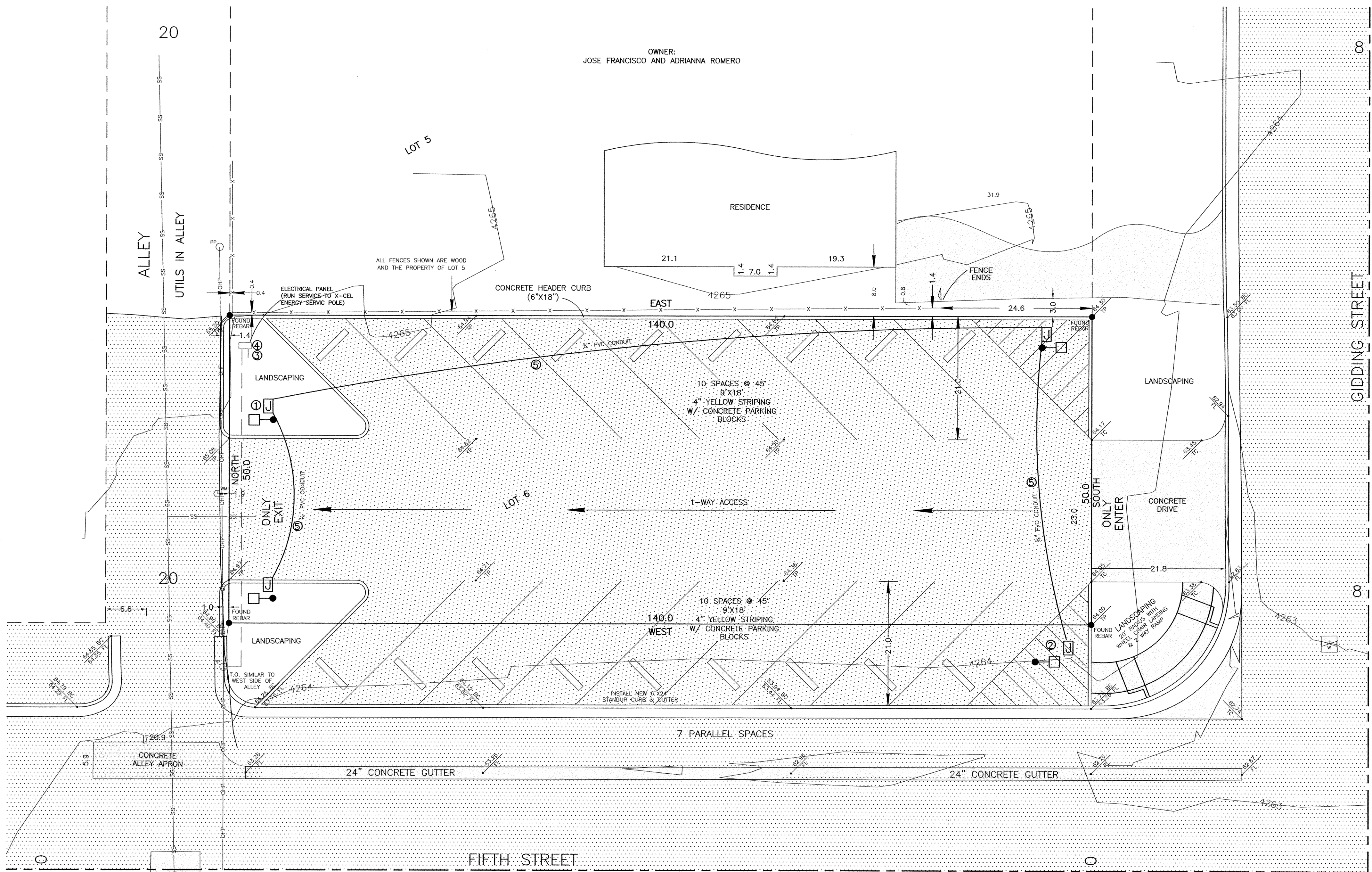

ELECTRICAL NOTES

- 1 TYPICAL WIRE LIGHTS
120 VOLTS INTER & OUTER LIGHTS
LITHONIA LIGHTING MODEL
KAX LED SIZE 2
CATALOG # KAX2 LED P1 50K R4
MVOLT SPA DWHXD
OR EQUAL
- 2 12X12 JUNCTION BOXES
ELECTRICAL SERVICE 200 AMP 30
CIR RT PANEL & 2 POLE TIME
CLOCK, UNDERGROUND TO
ELECTRICAL POLE (XCEL ENERGY)
- 3 INSTALL UNISTRAL STAND FOR
ELECTRICAL SERVICE. SEE DETAIL
- 4 1 - #10 THHN COLOR
1 - #10 THHN WHITE
1 - #10 THHN GREEN
1 - 3/4" CONDUIT

LIGHTING PLAN
4 EACH-1-WAY LUMINAIRES WITH 12"x12" JUNCTION BOX
3/4" DIAMETER ELECTRICAL CONDUIT WITH ONE (1) SERVICE POLE
& METER-285 L.F.

PANEL SCHEDULES

CIR	LOAD	CIR	LOAD
1	LIGHT POLES	20	
1	SPRINKLERS	20	

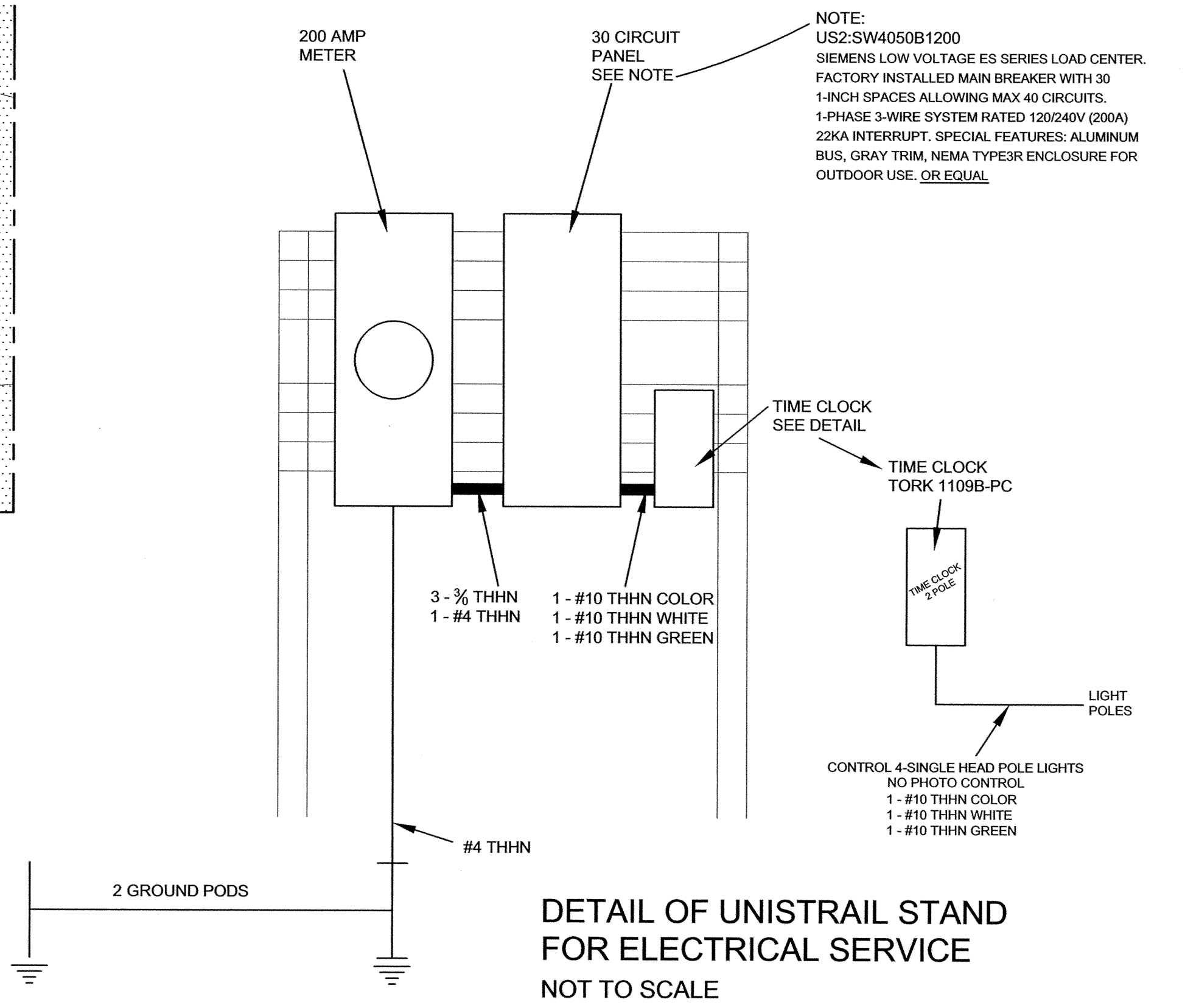
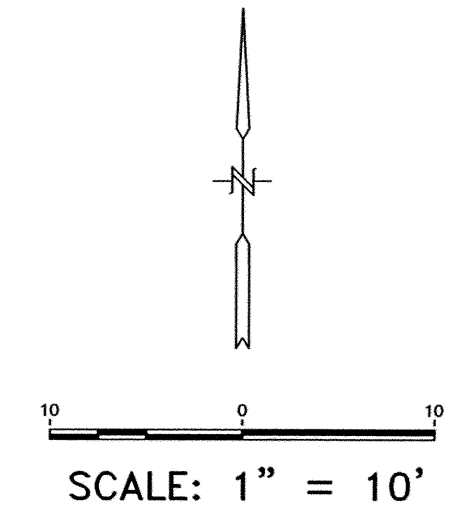

REV. NO.	DATE	DRWN	CHKD	REMARKS

DESIGNED BY: RCL
DRAWN BY: DPL
SHEET CHKD BY:
CROSS CHKD BY:
APPROVED BY:
DATE: 04/20/2021

LYDICK
ENGINEERS & SURVEYORS
205 E. SECOND STREET, CLOVIS, NM 88101
PH: 575-762-3771, FAX: 575-762-9093

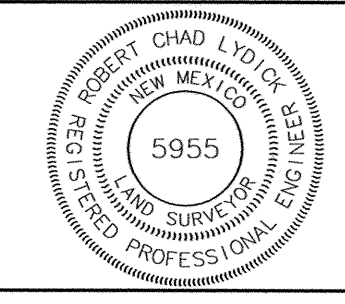

LOT 6 BLOCK 23
ORIGINAL TOWNSITE
CITY OF CLOVIS
CURRY COUNTY, NEW MEXICO

ELECTRICAL PLAN

PROJECT NO. 21992 B
FILE NAME: 21992 B.dwg
SHEET NO.
ES-101

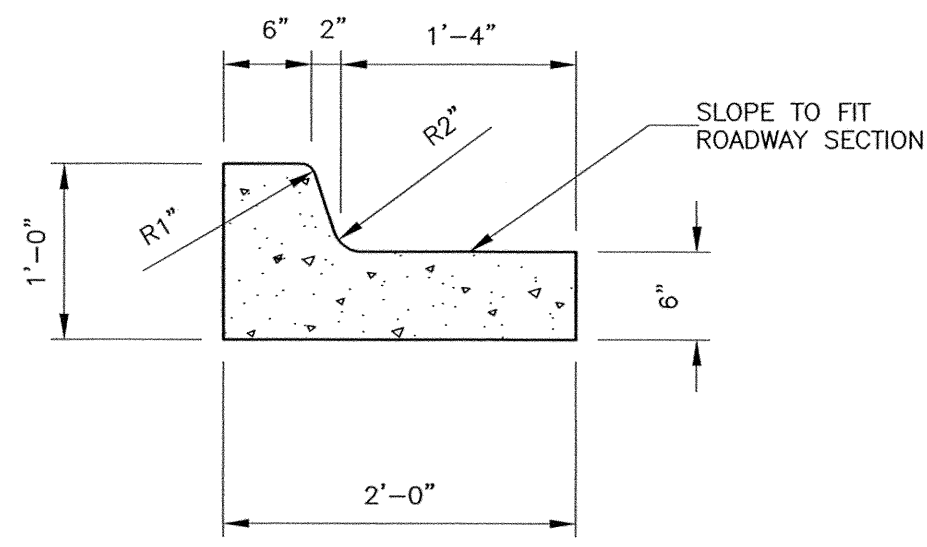

C1 6' x 24' TYPE "B" CONCRETE BARRIER CURB & GUTTER

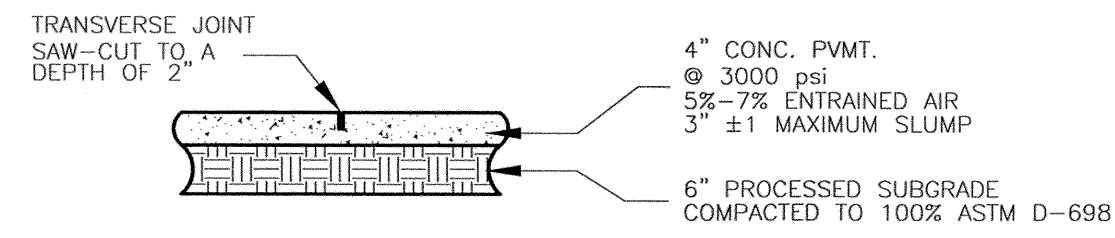

C2 PEDESTRIAN 4" CONCRETE PAVEMENT

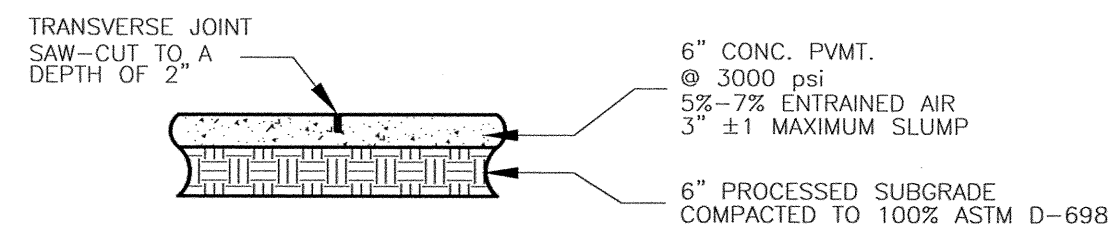

C3 DRIVE PAD 6" CONCRETE PAVEMENT

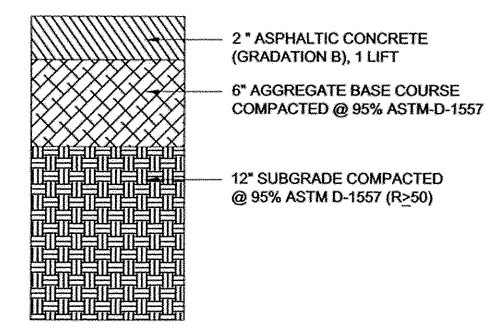

C4 ASPHALT PAVEMENT SECTION

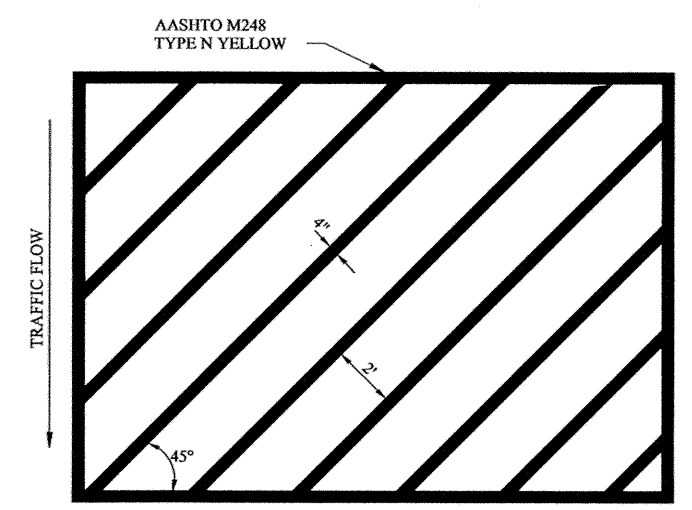

C6 TRAFFIC EXCLUSION DETAIL

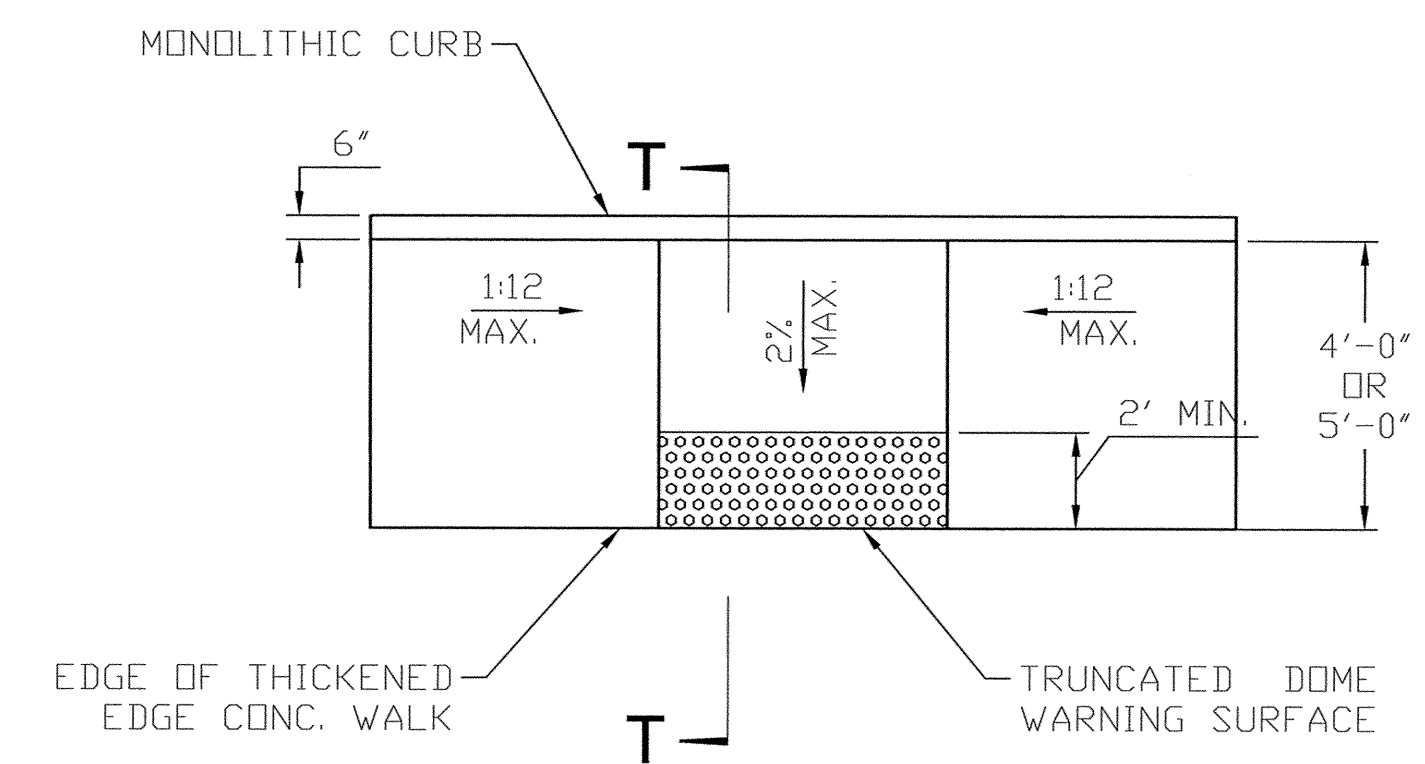

NOTE:
UTILIZE EXISTING WALL AS CURB ON THE CENTRALLY LOCATED ACCESS RAMP.

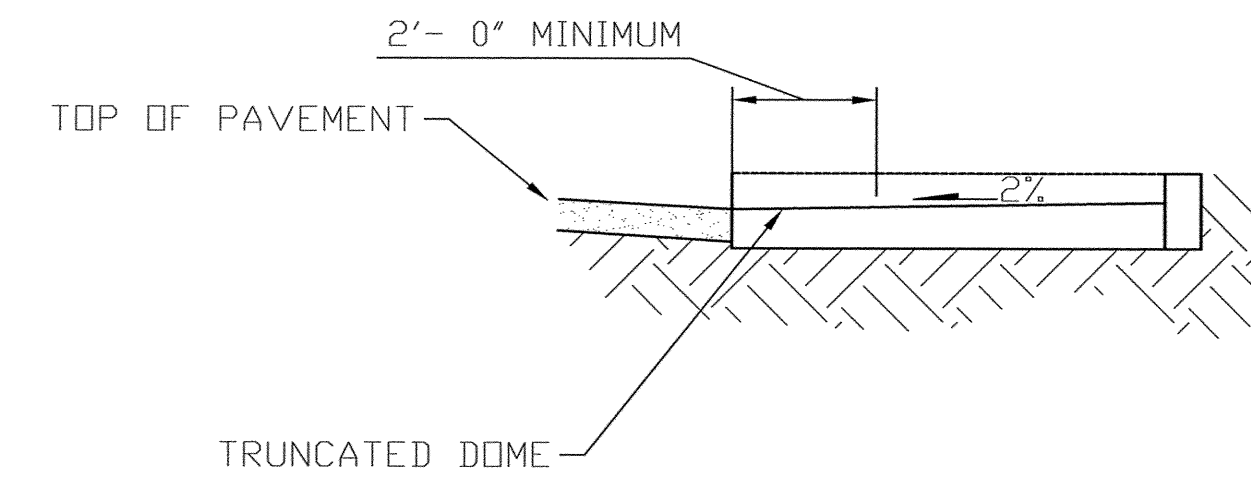

SECTION A-A

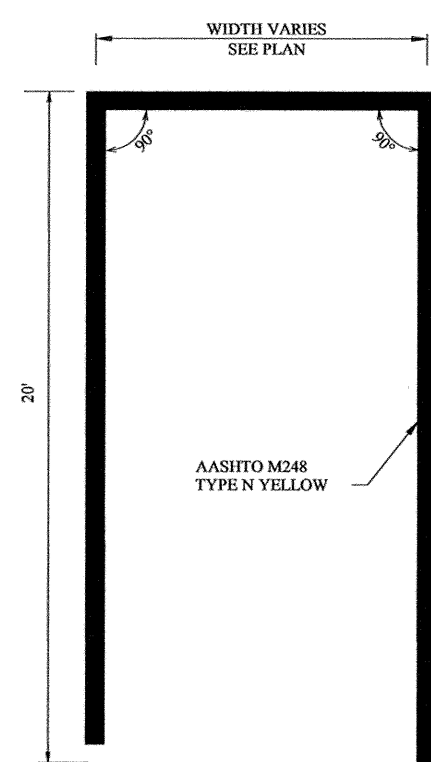

C7 PARKING AREA PAVMT. MARKING

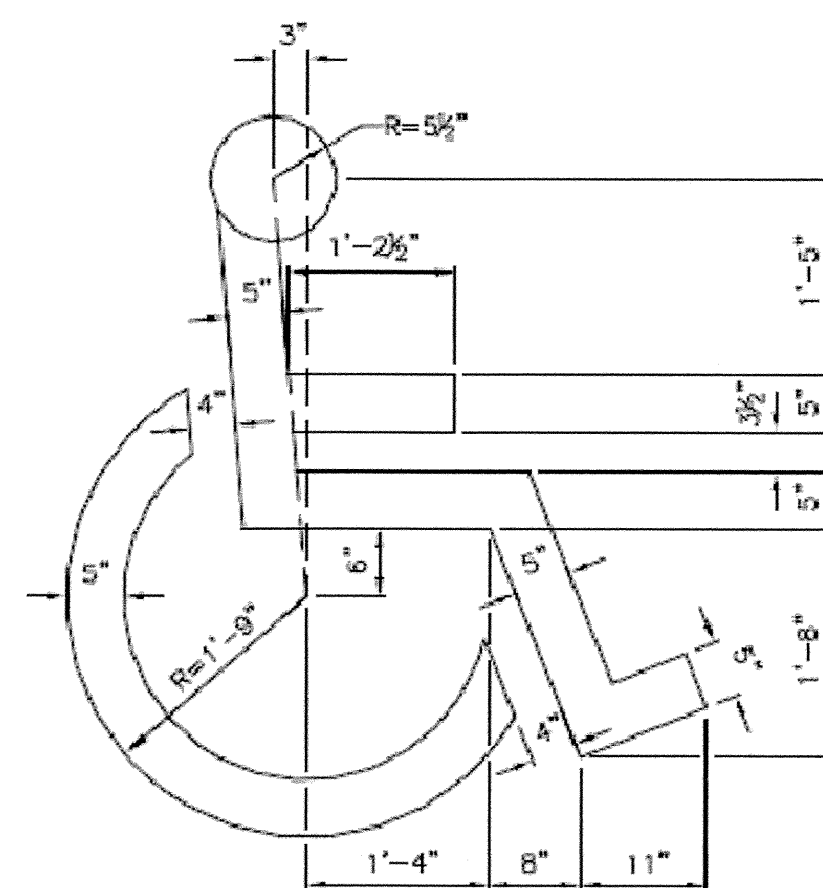

C8 HANDICAP SYMBOL DETAIL

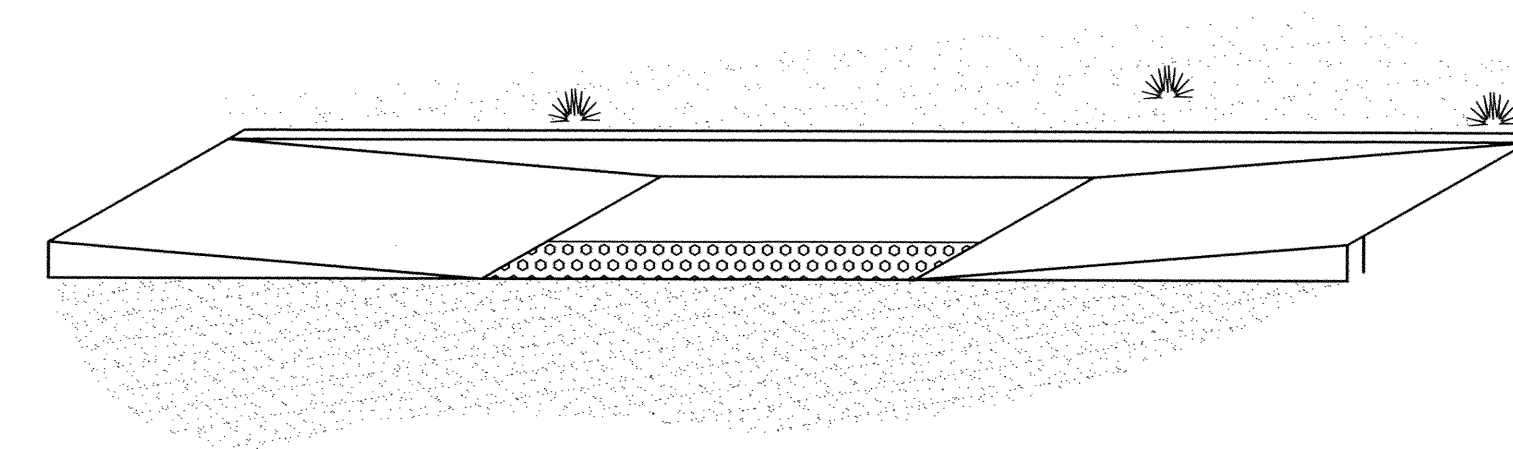

ISOMETRIC

C9 HANDICAP RAMP DETAIL

REV. NO.	DATE	DRWN	CHKD	REMARKS

DESIGNED BY: RCL
 DRAWN BY: DL
 SHEET CHK'D BY:
 CROSS CHK'D BY:
 APPROVED BY:
 DATE: 04/28/2021

LYDICK
 ENGINEERS & SURVEYORS
 205 E. SECOND STREET, CLOVIS, NM 88101
 PH: 575-762-3771, FAX: 575-762-9093

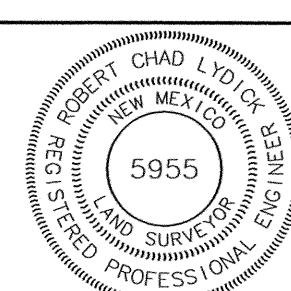

LOT 6 BLOCK 23
 ORIGINAL TOWNSITE
 CITY OF CLOVIS
 CURRY COUNTY, NEW MEXICO

CIVIL DETAILS

PROJECT NO. 21992 B
 FILE NAME: 21992 B.dwg
 SHEET NO.
C-501