

<b>COLLETON COUNTY SCHOOL DISTRICT</b>  <b>SEALED BID Invitation for Bid (IFB)</b>	Solicitation Number Date Issued Procurement Officer Phone E-Mail Address	<b>BG-PavingCCMSTCTC</b> 1/26/2022 Susan Crosby (843) 782-4510 EXT. 71400 smcrosby@colleton.k12.sc.us
--	--	---

**DESCRIPTION: Parking Lot Repairs CCMS & TCTC**

*The Term "Offer" Means Your "Bid" or "Proposal".*

SUBMIT OFFER BY (Opening Date/Time): **Tuesday, March 1, 2022 @ 11:00 AM**

QUESTIONS MUST BE RECEIVED BY: **Tuesday, February 15, 2022 @ 10:30 AM**  
Via E-mail: [kblakeney@colletonsd.org](mailto:kblakeney@colletonsd.org)

NUMBER OF COPIES TO BE SUBMITTED: **One (1) original and One (1) copy (marked 'copy')**

**Offers must be submitted in a sealed package. Solicitation Number & Opening Date must appear on package exterior.**

**SUBMIT YOUR SEALED OFFER TO EITHER OF THE FOLLOWING ADDRESSES:**

**MAILING ADDRESS:**  
Colleton County School District  
500 Forest Circle  
Walterboro, SC 29488

**PHYSICAL ADDRESS:**  
Colleton County School District  
500 Forest Circle  
Walterboro, SC 29488

<b>CONFERENCE TYPE: Pre-Bid (Non - Mandatory)</b> <b>DATE &amp; TIME: Tuesday, February 8, 2022 @ 11 AM</b> <b>***Sign in will be at CCMS and then we will move to TCTC.</b>	<b>LOCATION:</b> <b>CCMS 1379 Tuskegee Airmen Drive</b> <b>TCTC 1069 Thunderbolt Drive</b> <b>Walterboro, SC 29488</b>
--	---

<b>AWARD &amp; AMENDMENTS</b>	Award will be on <b>3/15/2022</b> . The award, this solicitation, and any amendments will be posted at the following web address: <a href="https://www.colleton.k12.sc.us/departments/procurement">https://www.colleton.k12.sc.us/departments/procurement</a>
-------------------------------	---

You must submit a signed copy of this form with Your Offer. By submitting a bid or proposal, you agree to be bound by the terms of the Solicitation. You agree to hold Your Offer open for a minimum of thirty (30) calendar days after the Opening Date.

<b>NAME OF OFFEROR</b>	(Full legal name of business submitting the offer)	<b>OFFEROR'S TYPE OF ENTITY:</b>
<b>AUTHORIZED SIGNATURE</b>		(Check one)
		<input type="checkbox"/> Sole Proprietorship <input type="checkbox"/> Partnership <input type="checkbox"/> Corporation (tax-exempt) <input type="checkbox"/> Corporate entity (not tax-exempt) <input type="checkbox"/> Government entity (federal, state, or local) <input type="checkbox"/> Other _____
<small>(Person signing must be authorized to submit binding offer to enter contract on behalf of Offeror named above.)</small>		
<b>TITLE</b>	(Business title of person signing above)	
<b>PRINTED NAME</b>	(Printed name of person signing above)	<b>DATE SIGNED</b>
		(See "Signing Your Offer" provision.)

Instructions regarding Offeror's name: Any award issued will be issued to, and the contract will be formed with, the entity identified as the offeror above. An offer may be submitted by only one legal entity. The entity named as the offeror must be a single and distinct legal entity. Do not use the name of a branch office or a division of a larger entity if the branch or division is not a separate legal entity, *i.e.*, a separate corporation, partnership, sole proprietorship, etc.

<b>STATE OF INCORPORATION</b>	(If offeror is a corporation, identify the state of Incorporation.)
<b>TAXPAYER IDENTIFICATION NO.</b>	<b>STATE VENDOR NO.</b>
<small>(See "Taxpayer Identification Number" provision)</small>	<small>(Register to Obtain S.C. Vendor No. at <a href="http://www.procurement.sc.gov">www.procurement.sc.gov</a>)</small>



(Return Page Two with Your Offer)

HOME OFFICE ADDRESS (Address for offeror's home office / principal place of business)	NOTICE ADDRESS (Address to which all procurement and contract related notices should be sent)			
	Area Code	Number	Extension	Facsimile
	E-mail Address			

PAYMENT ADDRESS (Address to which payments will be sent.)	ORDER ADDRESS (Address to which purchase orders will be sent)
Payment Address same as Home Office Address Payment Address same as Notice Address (check only one)	Order Address same as Home Office Address Order Address same as Notice Address (check only one)

ACKNOWLEDGMENT OF AMENDMENTS	Amendment No.	Amendment Issue Date	Amendment No.	Amendment Issue Date	Amendment No.	Amendment Issue Date	Amendment No.	Amendment Issue Date
	Offerors acknowledges receipt of amendments by indicating amendment number and its date of issue.							
See "Amendments to Solicitation" Provision								

DISCOUNT FOR PROMPT PAYMENT See "Discount for Prompt Payment" clause	10 Calendar Days (%)	20 Calendar Days (%)	30 Calendar Days (%)	_____ Calendar Days (%)
---	----------------------	----------------------	----------------------	-------------------------

<p>PREFERENCES – SC RESIDENT VENDOR PREFERENCE (June 2005): Section 11-35-1524 provides a preference for offerors that qualify as a resident vendor. A resident vendor is an offeror that (a) is authorized to transact business within South Carolina, (b) maintains an office* in South Carolina, (c) either (1) maintains a minimum \$10,000.00 representative inventory at the time of the solicitation, or (2) is a manufacturer which is headquartered and has at least a ten million dollar payroll in South Carolina, and the product is made or processed from raw materials into a finished end-product by such manufacturer or an affiliate (as defined in section 1563 of the Internal Revenue Code) of such manufacturer, and (d) has paid all assessed taxes. If applicable, preference will be applied as required by law.</p>	<p><b>OFFERORS REQUESTING THIS PREFERENCE MUST INITIAL HERE.</b> _____.</p>
	<p>*ADDRESS AND PHONE OF IN-STATE OFFICE</p>
	<p>In-State Office Address same as Home Office Address In-State Office Address same as Notice Address (CHECK ONLY ONE)</p>

<p>PREFERENCES – SC/US END-PRODUCT (June 2005): Section 11-35-1524 provides a preference to vendors offering South Carolina end-products or US end-products, if those products are made, manufactured, or grown in SC or the US, respectively. An end-product is the item identified for acquisition in this solicitation, including all component parts in final form and ready for the use intended. The terms "made," "manufactured," and "grown" are defined by Section 11-35-1524(B). By signing your offer and checking the appropriate space(s) provided and identified on the bid schedule, offeror certifies that the end-product(s) is either made, manufactured or grown in South Carolina, or other states of the United States, as applicable. Preference will be applied as required by law.</p>	<p><b>IF THIS PREFERENCE APPLIES TO THIS PROCUREMENT, PART VII (BIDDING SCHEDULE) WILL INCLUDE A PLACE TO CLAIM THE PREFERENCE.</b></p> <p><b>OFFERORS REQUESTING THIS PREFERENCE MUST CHECK THE APPROPRIATE SPACES ON THE BIDDING SCHEDULE.</b></p>
--	--

Specifications begin on page 12



## INSTRUCTIONS TO OFFERERS

**Submit Proposal and a completed W-9 form for your agency in a sealed envelope with the IFB number as well as the time and date for opening prominently marked on the outside.**

Bids must be submitted to or at the time, date and exact location specified to be considered. No late bids, telegraphic, or telephonic bids will be accepted.

All bids must be signed by an authorized officer or employee of the offerer.

All information requested of the offerer must be entered in the appropriate space on the original forms. Failure to do so may be grounds for disqualification.

All information must be entered in ink or typewritten. Mistakes may be crossed out and corrected prior to submission, if initialed by the person signing the bid.

Corrections and/or modifications received after the closing time specified will not be accepted.

Time of delivery, defined as the number of calendar days between receipt of the order by the offerer and the receipt of goods or services by The School District, may be considered as one factor in determining the award.

Prices will be considered net if no discount is shown.

## GENERAL CONDITIONS

### **GENERAL PROVISIONS**

This solicitation does not commit the District to award a contract, to pay any costs incurred in the preparation of the quote/bid or to procure any goods or services.

An authorized individual who may bind the Offeror to provide the services in accordance with the specifications contained in this RFP/IFB must sign your quote/bid response. The quote/bid response must contain a statement to the effect that your quote/bid is firm for a period of thirty (30) days from the bid due date or longer if so required by the District.

Colleton County School District Procurement Code and Regulations govern and supersede any and all documents, proposals and policies, whether stated or implied.

The District assumes no responsibility for the delivery of any solicitation, addendum, solicitation response, or any other such correspondence by the US Postal service, electronic transmission, facsimile, or any other method.

In the event that a bid (with \$50,000.00 or greater in value) is unintentionally opened prior to the official time set for the bid opening, the employee opening such a bid shall immediately inform the Chief Procurement officer, or designee, who shall in the presence of another employee re-seal the envelope and note on envelope that it was opened in error.

**Addenda:** Addenda shall be issued prior to the RFQ/IFB submittal date and time for the purposes of modifying or interpreting the quote/bid/proposal instructions through additions, deletions, clarifications, or corrections. At the discretion of the District, if it becomes necessary to revise or clarify any part of this RFP/IFB, an addendum will be posted at

<https://www.colleton.k12.sc.us/departments/procurement>

Addenda shall be forwarded to all potential offerors who are known by the District to have received a complete copy of the RFP/IFB. No addenda shall be issued later than four (4) days prior to the RFP/IFB submittal date except to a) withdraw the RFP/IFB solicitation, or b) to postpone the RFQ/IFB submittal date and time. The Chief Procurement Officer, or other District employee, shall not be legally bound by any amendment or interpretation that is not in writing.



**Ambiguous Quotes/Bids:** Quotes/bids which are uncertain as to terms, delivery, quantity, or compliance with requirements and/or specifications may be rejected or otherwise disregarded.

**Approval of Publicity Releases:** The Contractor shall not have the right to include the District's name in its published list of customers, without prior approval of the District. The Contractor agrees not to publish or cite in any form any comments or quotes from District staff. Contractor further agrees not to refer to award of this contract in commercial advertising in such a manner as to state or imply that the products or services provided are endorsed or preferred by the District.

**Authorization and Acceptance:** The quote/bid/proposal must be signed by an authorized individual who may bind the Offeror to these services in accordance with the requirements contained in this RFQ/IFB/RFP. The quote/bid/proposal must contain a statement to the effect that your bid is firm for a period of thirty (30) days from the quote/bid/proposal due date or longer if so required by the District.

In the event that identical bids/proposals are received on like items, the Chief Procurement Officer shall award the quote/bid/proposal in accordance with the District's Procurement Code.

**Bidder's Qualification:** No quote, bid or proposal shall be accepted from, and no contract will be awarded to, any person, firm, or corporation that is deemed irresponsible or unreliable to the District.

**Clarifications:** The District reserves the right, at any time after opening and prior to award, to request from any Proposer clarification, address technical questions, or to seek or provide other information regarding the Proposer's bid. Such a process may be used for such purposes as providing an opportunity for the Proposer to clarify his quote/bid/proposal in order to assure mutual understanding and/or aid in determinations of responsiveness or responsibility.

**Competition:** There are no Federal or State laws that prohibit Proposers from submitting a quote/bid/proposal lower than a price or quote/bid/proposal given to the United States Government. Proposers may submit a quote/bid/proposal lower than United States Government Contract price without any liability because the State is exempt from the provisions of the Robinson-Patman Act and other related laws.

**Confidentiality:** Ownership of all data, material and documentation originated and prepared pursuant to this RFQ/IFB/RFP shall belong exclusively to the District and be subject to public inspection in accordance with the Freedom of Information Act. However, commercial and/or financial information which is confidential or privileged included in bids will not be disclosed if such information has been identified by the firm as confidential. All firms who wish to have selected information in their bids remain confidential must visibly mark as "Confidential" each part of the quote/quote/bid/proposal they consider to contain proprietary information.

**Covenant against Contingent Fees:** The vendor warrants that no person or selling agency has been employed or retained to solicit or secure this contract upon an agreement or understanding for a commission, percentage, brokerage, or contingent fee, excepting bona fide employees or bona fide established commercial or selling agencies maintained by the vendor for the purpose of securing business. For breach or violation of this warranty, the School District of Colleton County shall have the right to annul this contract without liability or in its discretion to deduct from the contract price or consideration, or otherwise recover the full amount of such commission, percentage, brokerage, or contingent fee.

**Correction of Errors in the quote/bid/proposal:** All prices and notations should be printed in ink or typewritten. Errors should be crossed out, corrections entered and initialed by the person signing the quote/quote/bid/proposal. Erasures or use of typewriter correction fluid may be cause for rejection. No quote/bid/proposal shall be altered or amended after specified time for opening.





***District Closings:*** If an emergency or unanticipated event interrupts normal District processes so that offers cannot be received at the Finance Office of the District by the exact time specified in the solicitation, the time specified for receipt of offers will be deemed to be extended to the same time of day specified in the solicitation on the first work day on which normal District processes resume. In lieu of an automatic extension, an Amendment may be issued to reschedule bid opening. If District offices are closed at the time a pre-bid or pre-proposal conference is scheduled, an Amendment will be issued to reschedule the conference. Useful information may be available at [www.colleton.k12.sc.us](http://www.colleton.k12.sc.us)

***District Regulations:*** The vendor(s) and his representatives shall follow all applicable regulations while on District property, including the NO SMOKING, no weapons, and drug-free policies. No work shall interfere with school activities or environments unless an authorized employee for that location gives permission.

***Explanation to Prospective Bidders/Proposers:***

Any prospective Bidder/Proposer desiring an explanation or interpretation of this solicitation shall request it in writing soon enough to allow a reply to reach all prospective Bidders/Proposers before submission of their quote/bid/proposal.

Oral explanation and/or instructions given before the award of the contract shall not be binding.

Any information given to a prospective Bidder/Proposer pertaining to this solicitation shall be furnished promptly to other prospective Bidders/Proposers as an amendment, if that information is necessary in submitting a quote/bid/proposal, or if the lack of it would be prejudicial to other prospective Bidders/Proposers.

***Examination of Records:***

The School District of Colleton County shall have until three (3) years after final payment under this contract access to and the right to examine any of the Contractor's directly pertinent books, documents, papers or other records involving transactions related to this contract.

The contractor agrees to include in first-tier subcontracts under this contract, a clause to the effect that the Superintendent of the School District of Colleton County, or her duly authorized representative(s), shall, until three (3) years after final payment under the subcontract, have access to and the right to examine any of the subcontractor's directly pertinent books, documents, papers or other records involving transactions related to the subcontract(s).

***Interpretations:*** If any questions arise from this solicitation, respondents must contact the District's Finance Department. Any response to the respondent's request for interpretation of documents will be made by addendum if the Finance Department believes the interpretation is not clear in the bid document. The District will not be responsible for any other explanation or interpretations.

***Prohibition Against Conflicts of Interest, Gratuities and Kickbacks:*** "Any employee or any official of the District, elective or appointive, who shall take, receive or offer to take or receive either directly or indirectly, any rebate, percentage of contract, money or other things of value, as an inducement or intended inducement, in the procurement of business, or the giving of business, for, or to, or from, any person, partnership, firm of corporation, offering, bidding for, or in open market seeking to make sales to the District shall be deemed guilty of a felony and upon conviction such person or persons shall be subject to punishment or a fine in accordance with State and/or Federal laws."

***Quote/bid/proposal Constitutes Offer:*** By submitting a quote/bid/proposal, the Offeror agrees to be governed by the terms and conditions as set forth in this document. Any quote/bid/proposal containing variations from the terms and conditions set forth herein may, at the sole discretion of the District, render such quote/bid/proposal nonresponsive. Any inconsistencies between the RFQ/IFB/RFP and any other contractual instrument shall be governed by the terms and conditions of this RFQ/IFB/RFP, except where subsequent amendments to any contract



resulting from this RFQ/IFB/RFP award are specifically agreed to in writing by the parties to supersede any such provisions of this RFQ/IFB/RFP.

**Quote/bid/proposal Expenses:** The District or any of its representatives shall not be held responsible for any expenses incurred in the preparation or subsequent presentation of the vendor's response to this solicitation.

**Posting of Award (applies to contracts in excess of \$50,000.00):** Notice of Award or Intent to Award will be posted on the District's Website:

<https://www.colleton.k12.sc.us/departments/procurement>

**Proper Invoice:** Invoices submitted for payment for goods or services provided under this contract shall contain, as a minimum, the following information:

- Name of business
- Contract number or other authorization for delivery of service or property
- Complete description
- Price and quantity of property or service actually delivered or executed
- Shipping and payment terms
- Name where applicable
- Title, telephone number and complete mailing address of responsible official to whom payment is to be sent; and
- Other substantiating documentation of information as required by the contract

**Proposer's Qualifications:** Quotes/Bids/Proposals shall be considered only from Proposers who are regularly established in the business called for and who in the judgment of the District are financially responsible and able to show evidence of their reliability, ability, experience, equipment supervised by them to render prompt and satisfactory service in the volume called for under this contract.

**Rejection/Cancellation:** The District reserves the right, to accept or reject, in part or in entirety, any or all quotes/bids/proposals, to negotiate with all qualified proposers and to cancel in part or in entirety this solicitation if it is in the best interest of the District. Further, the District reserves the right to waive any or all informalities or technicalities in order to serve the best interest of the District.

**Responses:** All responses to this solicitation must comply completely with the requirements and schedule indicated in this solicitation to be considered for evaluation. All vendor(s) must be able to meet or exceed any and all requirements.

**Site Visits:** The District reserves the right to make site visits to the successful contractor's operation facilities prior to and after award. Site visit may include:

Walk-through of warehouse and storage facilities.

Inspection and review of delivery fleet capabilities.

**Substitutions:** The materials and products described in the RFQ/IFB/RFP establish a standard of required function, dimension, appearance and quality to be met by any proposed substitution. Reference in the RFQ/IFB/RFP to the words "or approved alternate" shall be interpreted as establishing a standard of quality and shall not be construed as limiting competition. **Any deviation from the enclosed specifications must be documented on the quote/bid/proposal form.**

**Time of Completion:** Date of delivery shall be a consideration factor in the awarding process. The Proposer shall include with his/her quote/bid/proposal delivery dates for each item as requested, and shall furnish all items in accordance with the quote/bid/proposal solicitation unless an extension was granted by the District in writing.



**Unlawful Acts:** The District interprets a signed quote/bid/proposal as signifying that the accompanying quote/bid/proposal is not the result of, or affected by, any unlawful act of collusion with any other person or company engaged in the same line of business or commerce, or any other fraudulent act punishable under the state of South Carolina or United States laws.

**Withdrawal of Proposal Response:** A quote/bid/proposal response cannot be withdrawn after it is filed, unless the respondent makes a written request to the Chief Procurement Officer prior to the last date and time set for receipt of the quote/bid/proposal responses. If the District fails to accept the response or award a contract within thirty (30) days after the quote/bid/proposal opening date, the respondent must inform the District, in writing, that they do not wish for their response to continue to be considered.

## GENERAL PROVISIONS

1. **Assignment:** No contract or its provisions may be assigned, sublet, or transferred without the written consent of the Procurement Officer.
2. **Bid Bond:** Bids will be accompanied by a Proposer's bond or certified check equal to five percent (5%) of the total dollar value of the submitted bid. When bid bond is required, it shall be so stated in the Instructions to Proposers.
3. **Contractor Responsibility:** The Contractor alone will be held solely responsible to the District for performance of all Contractor obligations under any contract resulting from their quote/bid/proposal.
4. **Default:** In case of default by the contractor, the District reserves the right to purchase any or all items in default in open market, charging the contractor with any additional costs. The defaulting contractor shall not be considered a responsible bidder until the assessed charge has been satisfied.
5. **Drug-free Workplace:** By signing and submitting a bid, a proposer is certifying that it will comply with all requirements of the South Carolina Drug-Free Workplace Act, Section 44-107-10, ET Seq., S.C. Code Ann, (1976).
6. **Equal Opportunity:** The successful firm agrees not to refuse to hire, discharge, promote, demote, or to otherwise discriminate in matters of compensation against any person otherwise qualified solely because of race, creed, sex, national origin, ancestry or physical handicap.
7. **Force Majeure:** The Contractor shall not be liable for any excess costs if the failure to perform the contract arises out of causes beyond the control and without the fault or negligence of the contractor. Such causes may include, but are not restricted to acts of God or of the public enemy, acts of the government in either its sovereign or contractual capacity, fires, floods, epidemics, quarantine restrictions, strikes, freight embargoes, and unusually severe weather; but in every case the failure to perform must be beyond the control and without the fault or negligence of the contractor. If the failure to perform is caused by the default of a subcontractor, and if such default arises out of causes beyond the control of both the contractor and subcontractor, and without the fault or negligence of either of them, the contractor shall not be liable for any excess costs or failure to perform, unless the supplies or services to be furnished by the subcontractor were obtainable from other sources in sufficient time to permit the contractor to meet the required delivery schedule.
8. **Governing Laws:** All proposal documents submitted in response to this solicitation are governed under the laws of the State of South Carolina. Contractor must be authorized and/or licensed to do business in the State of South Carolina. Notwithstanding the fact that applicable statutes may exempt or exclude the successful offeror from requirements that it be authorized and/or licensed to do business in said state, by signing of this Agreement,



Contractor agrees to subject itself to the jurisdiction and process of the courts of the State of South Carolina or federal courts as to all matters and disputes arising or to arise under the Agreement and the performance thereof, including any questions as to the liability for taxes, licenses or fees levied by the State.

- 9. *Illegal Immigration:*** (applicable to service contracts only) By signing your offer, you certify that you will comply with the applicable requirements of Title 8, Chapter 14 of the South Carolina Code of laws and agree to provide to the District, upon request, any documentation required to establish either: (a) that Title 8, Chapter 14 is inapplicable to you and your subcontractors or sub-subcontractors; or (b) that you and your subcontractors or sub-subcontractors are in compliance with Title 8, Chapter 14. Pursuant to Section 8-14-60, "A person who knowingly makes or files any false, fictitious, or fraudulent document, statement, or report pursuant to this chapter is guilty of a felony and, upon conviction, must be fined within the discretion of the court or imprisoned for not more than five (5) years, or both." You agree to include in any contracts with your subcontractors' language requiring your subcontractors to (a) comply with the applicable requirements of Title 8, Chapter 14, and (b) include in their contracts with the sub-subcontractor's language requiring the sub-subcontractors to comply with the applicable requirements of Title 8, Chapter 14.
- 10. *Indemnification:*** The vendor(s) shall agree to hold the District harmless and to indemnify the District from every expense, liability, or any payment arising out of or through injury (including death) to any person(s) or damage to any property of any location in which work is located arising out of or suffered through any at or omission of the vendor(s).
- 11. *Installation:*** Where equipment is called for to be installed under this RFQ/IFB/RFP, it shall be placed, leveled and accurately fastened into place by the vendor. He/she shall be responsible for obtaining dimensions and other such data which may be required to assure exact fit to work under another contract or as intended by the District. The vendor shall be responsible for providing an appropriate amount of lead-in for equipment requiring electrical, water or other basic service. The District will normally be responsible for bringing the appropriate service to the lead-in. The vendor shall completely remove from the premises all packaging, crating, and other litter due to his/her work. He/she shall also be responsible for the cost of repair of any damage to existing work which is caused by him/her during the installation of his/her equipment.
- 12. *Insurance:*** Contractor shall maintain, throughout the performance of its obligations under this Agreement, a policy or policies of Worker's Compensation insurance with such limits as may be required by law, and a policy or policies of general liability insurance insuring against liability for injury to, and death of persons and damage to, and destruction of, property arising out of or based upon any act or omission of the Contractor or any of its subcontractors or their respective officers, directors, employees or agents. Such general liability insurance shall have limits sufficient to cover any loss or potential loss resulting from this contract.
- 13. *Licenses and Permits:*** During the term of the contract, the Contractor shall be responsible for obtaining and maintaining in good standing, all licenses (including professional licenses, if any), permits, inspections and related fees for each of any such licenses, permits and/or inspections required by the District, county, city or other government entity or unit to accomplish the work specified in this solicitation document and the contract.
- 14. *Minority Business:*** Specify if your firm is a South Carolina certified minority business. If so, please provide the District with a copy of the certificate. The South Carolina definition of a minority business is a business that is at least 51% owned, operated, and controlled by a minority; or in cases of a publicly-owned business, at least 51% of the stock must be owned by a minority. Such minorities include but are not limited to African Americans, Hispanic Americans, Native Americans, and Eskimos. At the end of each contract year, Contractor is to





annually report to the District, any sub-contractor that is a certified minority business and the monetary amount paid to that firm.

- 15. Non-Appropriations:** Any contract entered into by the District or its departments, employees or agents resulting from this RFQ/IFB/RFP shall be subject to cancellation without damages or further obligation when funds are not appropriated or otherwise made available to support continuation of performance in a subsequent fiscal period or appropriated year.
- 16. Offeror Responsibility:** Each Proposer shall fully acquaint himself/herself with conditions relating to the scope and restrictions attending the execution of the work under the conditions of this RFQ/IFB/RFP. It is expected that this will sometimes require on-site observation. The failure or omission of a Proposer to acquaint himself/herself with existing conditions shall in no way relieve the Proposer of any obligations with respect to this RFQ/IFB/RFP or contract.
- 17. Packaging and Delivery:** All Shipments shall be FOB destination, freight prepaid, to the District locations specified. Purchase order numbers and/or contract number(s) as appropriate, must be clearly stated on each carton or package, shipping ticket, invoice, and any/all other information related to the order.
- 18. Delivery Time:** A written schedule for ordering and delivery for each of the schools will be established and mutually agreed upon by the District and the successful bidder within five (5) working days after the date of award.
- 19. Delivery Conditions:** Deliveries shall be made to each school in the District on a regularly scheduled basis every week, Monday through Friday, except school holidays and closing days (due to inclement weather). All schedules for deliveries will remain constant throughout the duration of the contract. Any changes to the schedule must be mutually agreed upon by the successful bidder and the District.
- 20. Holiday Deliveries:** "Holidays" shall be defined as any week that has less than five (5) school days. If the holiday falls on a scheduled delivery day, the delivery shall be made on a day to be mutually agreed upon by the District and the successful contractor.

Drivers and helpers shall request the authorized school receiver, or the designated representative, to verify the accuracy of quantities of each item, brand and code numbers of each items and condition of merchandise. Each delivery ticket shall be signed by a designated school receiver. Variations from the norm, i.e., shortages, damages, etc., shall be noted on each ticket by the designated school receiver and initialed by both the truck driver and school receiver. The contractor shall not be required to issue credits for errors not detected at time of delivery, except for hidden damage.

Special or intermediate deliveries shall be required only if a contractor fails to deliver a product on a regularly scheduled delivery.

- 21. Protection of Existing Vegetation, Structures, Equipment, Utilities, and Improvements:** The Contractor shall preserve and protect all structures, equipment, and vegetation (such as grass, trees, and shrubs) on or adjacent to the work site, which is not to be removed and which does not unreasonably interfere with the work required under this contract. The Contractor shall only remove trees when specifically authorized to do so, and shall avoid damaging vegetation that will remain in place. If any limbs or branches of trees broken during contract performance, or by any careless operation of equipment, or by workmen, the Contractor shall trim those limbs or branches with a clean cut and paint the cut with tree pruning compound as directed by the District representative(s).

The Contractor shall protect from damage all existing improvements and utilities at or near



the work site and on adjacent property of a third party, the locations of which are known to or should be known by the Contractor. The Contractor shall repair any damages to those facilities, including those that are the property of a third party resulting from failure to comply with the requirements of this contract or failure to exercise reasonable care in performing the work. If the Contractor fails or refuses to repair the damaged property, the District representative(s) may recommend that the necessary work be performed and charge the cost to the Contractor.

- 22. Quality of Product:** (This clause does not apply to solicitations for service requirements). Unless otherwise indicated in this bid it is understood and agreed that any item offered or shipped on this RFQ/IFB/RFP shall be new and of first quality.

**Right to Protest:** Any prospective proposer, offeror, contractor, or subcontractor who is aggrieved in connection with the solicitation of a contract shall protest to the Chief Procurement Officer within fifteen (15) days of the date of issuance of the RFQ/IFB/RFP or other solicitation documents whichever is applicable or any amendment thereto, if the amendment is at issue. Any protest must be addressed to the Chief Procurement Officer, Colleton County School District, and submitted in writing (a) by email to [smcrosby@colleton.k12.sc.us](mailto:smcrosby@colleton.k12.sc.us) (b) by facsimile at 843-782-0021, or (c) post or delivery to 500 Forest Circle, Walterboro, SC 29488

- 23.** Any actual proposer, offeror, contractor, or subcontractor who is aggrieved in connection with the intended award or award of a contract shall protest to the Chief Procurement Officer within ten (10) days of the date the notification of award is posted. Shall not apply to small purchases (under \$50,000 in actual or potential value).

- 24. Save Harmless:** (This clause does not apply to solicitations for service requirements). The successful proposer shall indemnify and save harmless the District, all officers, agents and employees from all suits or claims of any character brought by reason of infringing on any patent trade mark, or copyright. Proposer shall have no liability to the District if such patent, trademark or copyright infringement or claim is based upon the Proposer's use of material furnished to the Proposer by the District.

- 25. Subcontractors:** Any bidder in response to this RFQ/IFB/RFP shall set forth in his quote/bid/proposal the name of each subcontractor. If the bidder determines to use his own employees to perform any portion of the work for which he would otherwise be required to list a subcontractor and if the proposer is qualified to perform such work under the terms of the RFQ/IFB/RFP, the proposer shall list himself in the appropriate place in his quote/bid/proposal and not subcontract any of that work except with the approval of the District for good cause shown.

If you intend to subcontract with another business for any portion of the work and that portion exceeds 3% of your price, your offer must identify that business and the portion of work which they are to perform.

**Submission of Data:** Each Proposer, upon request, shall submit evidence of liability insurance, Workmen's Compensation (if required), and other data regarding experience relating to this Quote/bid/proposal and proposes to satisfy the requirements of this solicitation and fulfillment of a contract. The contractor shall maintain during the entire period of his performance under this contract, the required minimum insurance covering all properties and activities that are encompassed in the performance of the Proposal requirements. The successful vendor must furnish a statement of Workers' Compensation as required by law and by entering into contract guarantees that said contractor will not file a claim against Colleton County School District.



Prior to the commencement of work hereunder, successful contractor shall furnish to the District, a certificate of the above insurance requirements. The policies evidencing required insurance shall contain an endorsement to the effect that cancellation or any material change in the policies adversely affecting the interests of the District in such insurance shall not be effective without 15 days' advance written notice to the District. Failure to replace any canceled insurance shall be deemed a breach of contract by the contractor.

26. **Substitutions:** Deliveries shall be made as ordered. Unauthorized substitutions and deviations from stated orders are prohibited.
27. **Termination:** Subject to the Provision below, the contract may be terminated by the District providing a thirty (30) day advance notice in writing is given to the contractor.
28. **Termination for Cause:** Termination by the District for cause, default or negligence on the part of the contractor shall be excluded from the foregoing provisions, termination costs, if any, shall not apply. The thirty (30) days advance notice requirement is waived and the default provision in this bid shall apply.

The District may, by written notice of default to the contractor, terminate this contract in whole or in part if the contractor fails to deliver supplies or to perform the services within the time specified in this contract or any extension.

29. **Unit Price Governing:** Unit prices will govern over extended prices unless otherwise stated in the RFQ/IFB.





## Department of Buildings & Grounds

**Kenny Blakeney, Director**

**500 Forest Circle • 246 Beach Road**

**Walterboro, SC 29488**

**Voice: 843-782-4523 • Fax: 843-539-1094**

**Email: [kblakeney@colletonsd.org](mailto:kblakeney@colletonsd.org).**



### Scope of Contract

#### 1.0 PURPOSE

The Colleton County School District is inviting qualified contractors to submit pricing for asphalt paving at Colleton County Middle School & Thunderbolt Career & Technology Center. A non-mandatory pre-bid will be held on Tuesday, February 8, 2022 at 11:00 a.m. The non-mandatory pre-bid will begin at 1379 Tuskegee Airmen Drive and will conclude at 1069 Thunderbolt Drive Walterboro, SC 29488.

All terms and conditions below are a part of this bid. No bid will be accepted unless these terms and conditions have been met. Rights are reserved to reject any and all bids. Bids which are not submitted in accordance with this request will be rejected.

#### 2.0 PROPOSER'S QUESTIONS

Bidders shall address any questions regarding this solicitation directly to the Buildings & Grounds Director, Kenny Blakeney at [kblakeney@colleton.k12.sc.us](mailto:kblakeney@colleton.k12.sc.us) and [lgrant@colleton.k12.sc.us](mailto:lgrant@colleton.k12.sc.us). Questions shall be in writing to the email given, referencing the IFB number.

#### Asphalt Paving

\$ \_\_\_\_\_ (Lump Sum) – CCMS

\$ \_\_\_\_\_ (Lump Sum) - TCTC





# Specifications

For

## **Colleton County School District Repaving and Parking Lot Repairs for Thunderbolt Career & Technology Center and Colleton County Middle School**

Architects Project No. 2626.01

September 12, 2021

Construction Documents



***Colleton County***

SCHOOL DISTRICT

PREPARING EVERY CHILD TODAY FOR TOMORROW



The FWA Group, PA - Architects  
P.O. Box 5910  
Hilton Head Island, SC 29938

**SECTION 00 0103  
PROJECT DIRECTORY**

**PART 1 GENERAL**

**1.01 SECTION INCLUDES**

- A. Identification of project team members and their contact information.

**1.02 OWNER:**

- A. Name: Colleton County School District.
1. Address: 500 Forest Circle.
  2. City: Walterboro.
  3. State: South Carolina.
  4. Zip Code: 29488.
  5. Telephone: 843.782.4510.
- B. Primary Contact: All correspondence from the Contractor to the Owner will be directed though the School District's Director of Buildings and Grounds, unless alternate arrangements are mutually agreed upon at preconstruction meeting.
1. Title: Director of Buildings and Grounds.
  2. Name: Mr. Kenny Blakeney.
  3. Email: kblakeney@colleton.k12.sc.us.

**1.03 CONSULTANTS:**

- A. Architect: Design Professional of Record. All correspondence from the Contractor regarding construction documents authored by Architect's consultants will be through this party, unless alternate arrangements are mutually agreed upon at preconstruction meeting.
1. Company Name: The FWA Group, PA - Architects.
    - a. Mail Address: P.O. Box 5910, Hilton Head Island, SC 29938.
    - b. Street Address: 10 Palmetto Business Park Road, Hilton Head Island, SC 29928.
    - c. Telephone: 843.785.2199.
  2. Primary Contact: .
    - a. Project Manager/Principal-in-Charge: Barry H. Taylor, AIA, LEED AP.
      - 1) Email Address: b.taylor@fwagroup.com.
    - b. Project Architect: Dale N. Strecker, AIA
      - 1) Email Address: d.strecker@fwagroup.com.
- B. Civil Engineering Consultant:
1. Company Name: Cranston Engineering Group, PC.
    - a. Address: 14 Westbury Park Way, Suite 202, Bluffton, SC 29910.
    - b. Telephone: 843.815.3191.
  2. Primary Contact: .
    - a. Project Manager: Matthew Randall, PE.
      - 1) Email: mrandall@cranstonengineering.com.

**PART 2 PRODUCTS - NOT USED**

**PART 3 EXECUTION - NOT USED**

**END OF SECTION**

**SECTION 00 0110**  
**TABLE OF CONTENTS**

**PROCUREMENT AND CONTRACTING REQUIREMENTS**

**1.01 DIVISION 00 -- PROCUREMENT AND CONTRACTING REQUIREMENTS**

- A. 00 0103 - Project Directory
- B. 00 0110 - Table of Contents
- C. 00 4200 - Proposal Form
- D. 00 5201 - AIA Document A105 - 2017 Standard Short Form of Agreement Between Owner and Contractor
- E. 00 5501 - AIA Document A701 - 2018 Instructions to Bidders
- F. 00 5502 - Supplemental Instructions to Bidders to AIA A701 - 2018

**SPECIFICATIONS**

**2.01 DIVISION 01 -- GENERAL REQUIREMENTS**

- A. 01 1000 - Summary
- B. 01 2000 - Price and Payment Procedures
- C. 01 3000 - Administrative Requirements
- D. 01 3553 - Security Procedures
- E. 01 4000 - Quality Requirements
- F. 01 4100 - Regulatory Requirements
- G. 01 4216 - Definitions
- H. 01 5000 - Temporary Facilities and Controls
- I. 01 5100 - Temporary Utilities
- J. 01 6000 - Product Requirements
- K. 01 7000 - Execution and Closeout Requirements
- L. 01 7800 - Closeout Submittals

**2.02 DIVISION 02 -- EXISTING CONDITIONS (NOT USED)**

**2.03 DIVISION 03 -- CONCRETE (NOT USED)**

**2.04 DIVISION 04 -- MASONRY (NOT USED)**

**2.05 DIVISION 05 -- METALS (NOT USED)**

**2.06 DIVISION 06 -- WOOD, PLASTICS, AND COMPOSITES (NOT USED)**

**2.07 DIVISION 07 -- THERMAL AND MOISTURE PROTECTION (NOT USED)**

**2.08 DIVISION 08 -- OPENINGS (NOT USED)**

**2.09 DIVISION 09 -- FINISHES (NOT USED)**

**2.10 DIVISION 10 -- SPECIALTIES (NOT USED)**

**2.11 DIVISION 11 -- EQUIPMENT (NOT USED)**

**2.12 DIVISION 12 -- FURNISHINGS (NOT USED)**

**2.13 DIVISION 13 -- SPECIAL CONSTRUCTION (NOT USED)**

**2.14 DIVISION 14 -- CONVEYING EQUIPMENT (NOT USED)**

**2.15 DIVISION 22 -- PLUMBING (NOT USED)**

**2.16 DIVISION 23 -- HEATING, VENTILATING, AND AIR-CONDITIONING (HVAC) (NOT USED)**

**2.17 DIVISION 26 -- ELECTRICAL (NOT USED)**

**2.18 DIVISION 32 -- EXTERIOR IMPROVEMENTS**

- A. Proposal for Civil Engineering Services - Colleton County Middle School
  - 1. Special Provisions
  - 2. Supplemental Specifications
  - 3. Proposal Section
- B. Proposal for Civil Engineering Services - Thunderbolt Career and Technology Center
  - 1. Special Provisions
  - 2. Suuplemental Specifications
  - 3. Proposal Section

**END OF SECTION**

**SECTION 00 4200  
PROPOSAL FORM**

**PROPOSAL SUMMARY**

**1.01 PROJECT IDENTIFICATION AND INFORMATION**

- A. Proposal Form for the work at Colleton County Middle School is under Division 32 - Exterior Improvements A.3. Proposal Section.
- B. Proposal Form for the work at Thunderbolt Career & Technology Center is under Division 32 - Exterior Improvements B.3. Proposal Section.
- C. Contractors are to submit both proposal forms for the work at the two schools in the same bid envelop as both projects will be accepted as one combined project by the School District.
  - 1. The proposal package the contractor is to complete is to include the Proposal Form, Certification Form, Performance Bond, Labor and Materials Payment Bond, Bid Bond (guarantee) or Certified Check payable to Colleton County School District.
- D. Clarification of Bonding, Notice of Award and Notice to Proceed Requirements for this Work:
  - 1. Each Proposal must be accompanied by a Bid Bond or Certified Check payable to the Owner for five percent (5%) of the total amount of the Bid. As soon as the Bid prices have been compared, the Owner will return the Bonds of all except the three lowest responsible Bidders. When the Agreement is executed the bonds of the two remaining unsuccessful bidders will be returned. The Bid Bond of the successful Bidder will be retained until the Payment and Performance Bonds have been executed and approved, after which it will be returned.
  - 2. A Performance Bond and a Payment Bond each in the amount of one hundred percent (100%) of the contract price, with a corporate surety approved by the Owner, will be required for the faithful performance of the contract.
  - 3. Attorney-in-fact who sign Bid Bonds or Payment Bonds and Performance Bonds must file with each Bond a certified and effective dated copy of their power of attorney.
  - 4. The party to whom the contract is awarded will be required to execute the Agreement and obtain the Performance Bond and Payment Bond within ten (10) calendar days from the date when Notice to Award is delivered to the Bidder. In case of failure of the Bidder to execute the Agreement, the Owner may consider the Bidder in default, in which case the Bid Bond or Certified Check accompanying the proposal shall become the property of the Owner.
  - 5. The Owner within ten (10) days of receipt of the acceptable Performance Bond, Payment Bond, and Agreement signed by the party to whom the Agreement was awarded shall sign the Agreement and return to such party an executed duplicate of the Agreement. Should the Owner not execute the Agreement within such period, the Bidder may by written notice withdraw the signed Agreement. Such notice of withdrawal shall be effective upon receipt of the notice by the Owner.
  - 6. The Notice to Proceed shall be issued within ten (10) days of the execution of the Agreement by the Owner. Should there be reasons why the Notice to Proceed cannot be issued within such period, the time may be extended by mutual agreement between the Owner and Contractor. If the Notice to Proceed has not been issued within the ten (10) day period or within the period mutually agreed upon, the Contractor may terminate the agreement without further liability on the part of either party.
  - 7. The Owner may make such investigations as deemed necessary to determine the ability of the Bidder to perform the Work, and the Bidder shall furnish to the Owner all such information and data for this purpose as the Owner may request. The Owner reserves the right to reject any Bid if the evidence submitted by, or investigation of, such Bidder fails to satisfy the Owner that such Bidder is properly qualified to carry out the obligations of the Agreement and to complete the Work contemplated therein.

- E. The final agreement for the work will be the AIA A105-2017 Agreement as presented in this project manual under "Section 00 5201 - AIA Document A105-2017 Standard Form of Short Form of Agreement Between Owner and Contractor".

**END OF SECTION**



**AIA**<sup>®</sup>

# Document A105<sup>™</sup> – 2017

## Standard Short Form of Agreement Between Owner and Contractor

AGREEMENT made as of the \_\_\_\_\_ day of \_\_\_\_\_ in the year \_\_\_\_\_  
*(In words, indicate day, month and year.)*

**BETWEEN** the Owner:  
*(Name, legal status, address and other information)*

This document has important legal consequences. Consultation with an attorney is encouraged with respect to its completion or modification.

and the Contractor:  
*(Name, legal status, address and other information)*

for the following Project:  
*(Name, location and detailed description)*

The Architect:  
*(Name, legal status, address and other information)*

The Owner and Contractor agree as follows.

Init.

AIA Document A105<sup>™</sup> – 2017. Copyright © 1993, 2007 and 2017 by The American Institute of Architects. All rights reserved. **WARNING: This AIA<sup>®</sup> Document is protected by U.S. Copyright Law and International Treaties. Unauthorized reproduction or distribution of this AIA<sup>®</sup> Document, or any portion of it, may result in severe civil and criminal penalties, and will be prosecuted to the maximum extent possible under the law. To report copyright violations of AIA Contract Documents, e-mail The American Institute of Architects' legal counsel, [copyright@aia.org](mailto:copyright@aia.org).**

**TABLE OF ARTICLES**

- 1 THE CONTRACT DOCUMENTS
- 2 DATE OF COMMENCEMENT AND SUBSTANTIAL COMPLETION
- 3 CONTRACT SUM
- 4 PAYMENTS
- 5 INSURANCE
- 6 GENERAL PROVISIONS
- 7 OWNER
- 8 CONTRACTOR
- 9 ARCHITECT
- 10 CHANGES IN THE WORK
- 11 TIME
- 12 PAYMENTS AND COMPLETION
- 13 PROTECTION OF PERSONS AND PROPERTY
- 14 CORRECTION OF WORK
- 15 MISCELLANEOUS PROVISIONS
- 16 TERMINATION OF THE CONTRACT
- 17 OTHER TERMS AND CONDITIONS

**ARTICLE 1 THE CONTRACT DOCUMENTS**

The Contractor shall complete the Work described in the Contract Documents for the Project. The Contract Documents consist of

- .1 this Agreement signed by the Owner and Contractor;
- .2 the drawings and specifications prepared by the Architect, dated \_\_\_\_\_, and enumerated as follows:

Drawings:  
Number Title Date

Specifications:  
Section Title Pages



.3 addenda prepared by the Architect as follows:

Number

Date

Pages

.4 written orders for changes in the Work, pursuant to Article 10, issued after execution of this Agreement;  
and

.5 other documents, if any, identified as follows:

## ARTICLE 2 DATE OF COMMENCEMENT AND SUBSTANTIAL COMPLETION

§ 2.1 The Contract Time is the number of calendar days available to the Contractor to substantially complete the Work.

### § 2.2 Date of Commencement:

Unless otherwise set forth below, the date of commencement shall be the date of this Agreement.

*(Insert the date of commencement if other than the date of this Agreement.)*

### § 2.3 Substantial Completion:

Subject to adjustments of the Contract Time as provided in the Contract Documents, the Contractor shall achieve Substantial Completion, as defined in Section 12.5, of the entire Work:

*(Check the appropriate box and complete the necessary information.)*

Not later than ( ) calendar days from the date of commencement.

By the following date:

## ARTICLE 3 CONTRACT SUM

§ 3.1 The Contract Sum shall include all items and services necessary for the proper execution and completion of the Work. Subject to additions and deductions in accordance with Article 10, the Contract Sum is: (\$ )

§ 3.2 For purposes of payment, the Contract Sum includes the following values related to portions of the Work:

*(Itemize the Contract Sum among the major portions of the Work.)*

Portion of the Work

Value

§ 3.3 The Contract Sum is based upon the following alternates, if any, which are described in the Contract Documents and hereby accepted by the Owner:

*(Identify the accepted alternates. If the bidding or proposal documents permit the Owner to accept other alternates subsequent to the execution of this Agreement, attach a schedule of such other alternates showing the amount for each and the date when that amount expires.)*

§ 3.4 Allowances, if any, included in the Contract Sum are as follows:  
(Identify each allowance.)

Item	Price
------	-------

§ 3.5 Unit prices, if any, are as follows:  
(Identify the item and state the unit price and quantity limitations, if any, to which the unit price will be applicable.)

Item	Units and Limitations	Price per Unit (\$0.00)
------	-----------------------	-------------------------

#### ARTICLE 4 PAYMENTS

§ 4.1 Based on Contractor's Applications for Payment certified by the Architect, the Owner shall pay the Contractor, in accordance with Article 12, as follows:

(Insert below timing for payments and provisions for withholding retainage, if any.)

§ 4.2 Payments due and unpaid under the Contract Documents shall bear interest from the date payment is due at the rate below, or in the absence thereof, at the legal rate prevailing at the place of the Project.

(Insert rate of interest agreed upon, if any.)

%

#### ARTICLE 5 INSURANCE

§ 5.1 The Contractor shall maintain the following types and limits of insurance until the expiration of the period for correction of Work as set forth in Section 14.2, subject to the terms and conditions set forth in this Section 5.1:

§ 5.1.1 Commercial General Liability insurance for the Project, written on an occurrence form, with policy limits of not less than (\$ ) each occurrence, (\$ ) general aggregate, and (\$ ) aggregate for products-completed operations hazard.

§ 5.1.2 Automobile Liability covering vehicles owned, and non-owned vehicles used, by the Contractor, with policy limits of not less than (\$ ) per accident, for bodily injury, death of any person, and property damage arising out of the ownership, maintenance, and use of those motor vehicles along with any other statutorily required automobile coverage.

§ 5.1.3 The Contractor may achieve the required limits and coverage for Commercial General Liability and Automobile Liability through a combination of primary and excess or umbrella liability insurance, provided that such primary and excess or umbrella insurance policies result in the same or greater coverage as those required under Section 5.1.1 and 5.1.2, and in no event shall any excess or umbrella liability insurance provide narrower coverage than the primary policy. The excess policy shall not require exhaustion of the underlying limits only through the actual payment by the underlying insurers.

Init.

§ 5.1.4 Workers' Compensation at statutory limits.

§ 5.1.5 Employers' Liability with policy limits not less than (\$ ) each accident, (\$ ) each employee, and (\$ ) policy limit.

§ 5.1.6 The Contractor shall provide builder's risk insurance to cover the total value of the entire Project on a replacement cost basis.

**§ 5.1.7 Other Insurance Provided by the Contractor**

*(List below any other insurance coverage to be provided by the Contractor and any applicable limits.)*

Coverage	Limits
----------	--------

§ 5.2 The Owner shall be responsible for purchasing and maintaining the Owner's usual liability insurance and shall provide property insurance to cover the value of the Owner's property. The Contractor is entitled to receive an increase in the Contract Sum equal to the insurance proceeds related to a loss for damage to the Work covered by the Owner's property insurance.

§ 5.3 The Contractor shall obtain an endorsement to its Commercial General Liability insurance policy to provide coverage for the Contractor's obligations under Section 8.12.

§ 5.4 Prior to commencement of the Work, each party shall provide certificates of insurance showing their respective coverages.

§ 5.5 Unless specifically precluded by the Owner's property insurance policy, the Owner and Contractor waive all rights against (1) each other and any of their subcontractors, suppliers, agents, and employees, each of the other; and (2) the Architect, Architect's consultants, and any of their agents and employees, for damages caused by fire or other causes of loss to the extent those losses are covered by property insurance or other insurance applicable to the Project, except such rights as they have to the proceeds of such insurance.

**ARTICLE 6 GENERAL PROVISIONS**

**§ 6.1 The Contract**

The Contract represents the entire and integrated agreement between the parties and supersedes prior negotiations, representations or agreements, either written or oral. The Contract may be amended or modified only by a written modification in accordance with Article 10.

**§ 6.2 The Work**

The term "Work" means the construction and services required by the Contract Documents, and includes all other labor, materials, equipment, and services provided, or to be provided, by the Contractor to fulfill the Contractor's obligations.

**§ 6.3 Intent**

The intent of the Contract Documents is to include all items necessary for the proper execution and completion of the Work by the Contractor. The Contract Documents are complementary, and what is required by one shall be as binding as if required by all.

**§ 6.4 Ownership and Use of Architect's Drawings, Specifications and Other Documents**

Documents prepared by the Architect are instruments of the Architect's service for use solely with respect to this Project. The Architect shall retain all common law, statutory, and other reserved rights, including the copyright. The Contractor, subcontractors, sub-subcontractors, and suppliers are authorized to use and reproduce the instruments of service solely and exclusively for execution of the Work. The instruments of service may not be used for other Projects or for additions to this Project outside the scope of the Work without the specific written consent of the Architect.

## **§ 6.5 Electronic Notice**

Written notice under this Agreement may be given by one party to the other by email as set forth below.

*(Insert requirements for delivering written notice by email such as name, title, and email address of the recipient, and whether and how the system will be required to generate a read receipt for the transmission.)*

## **ARTICLE 7 OWNER**

### **§ 7.1 Information and Services Required of the Owner**

**§ 7.1.1** If requested by the Contractor, the Owner shall furnish all necessary surveys and a legal description of the site.

**§ 7.1.2** Except for permits and fees under Section 8.7.1 that are the responsibility of the Contractor, the Owner shall obtain and pay for other necessary approvals, easements, assessments, and charges.

**§ 7.1.3** Prior to commencement of the Work, at the written request of the Contractor, the Owner shall furnish to the Contractor reasonable evidence that the Owner has made financial arrangements to fulfill the Owner's obligations under the Contract. The Contractor shall have no obligation to commence the Work until the Owner provides such evidence.

### **§ 7.2 Owner's Right to Stop the Work**

If the Contractor fails to correct Work which is not in accordance with the Contract Documents, the Owner may direct the Contractor in writing to stop the Work until the correction is made.

### **§ 7.3 Owner's Right to Carry Out the Work**

If the Contractor defaults or neglects to carry out the Work in accordance with the Contract Documents and fails within a seven day period after receipt of written notice from the Owner to commence and continue correction of such default or neglect with diligence and promptness, the Owner may, without prejudice to other remedies, correct such deficiencies. In such case, the Architect may withhold or nullify a Certificate for Payment in whole or in part, to the extent reasonably necessary to reimburse the Owner for the cost of correction, provided the actions of the Owner and amounts charged to the Contractor were approved by the Architect.

### **§ 7.4 Owner's Right to Perform Construction and to Award Separate Contracts**

**§ 7.4.1** The Owner reserves the right to perform construction or operations related to the Project with the Owner's own forces, and to award separate contracts in connection with other portions of the Project.

**§ 7.4.2** The Contractor shall coordinate and cooperate with the Owner's own forces and separate contractors employed by the Owner.

## **ARTICLE 8 CONTRACTOR**

### **§ 8.1 Review of Contract Documents and Field Conditions by Contractor**

**§ 8.1.1** Execution of the Contract by the Contractor is a representation that the Contractor has visited the site, become familiar with local conditions under which the Work is to be performed, and correlated personal observations with requirements of the Contract Documents.

**§ 8.1.2** The Contractor shall carefully study and compare the Contract Documents with each other and with information furnished by the Owner. Before commencing activities, the Contractor shall (1) take field measurements and verify field conditions; (2) carefully compare this and other information known to the Contractor with the Contract Documents; and (3) promptly report errors, inconsistencies, or omissions discovered to the Architect.

### **§ 8.2 Contractor's Construction Schedule**

The Contractor, promptly after being awarded the Contract, shall prepare and submit for the Owner's and Architect's information a Contractor's construction schedule for the Work.

### **§ 8.3 Supervision and Construction Procedures**

**§ 8.3.1** The Contractor shall supervise and direct the Work using the Contractor's best skill and attention. The Contractor shall be solely responsible for and have control over construction means, methods, techniques, sequences, and procedures, and for coordinating all portions of the Work.

§ 8.3.2 The Contractor, as soon as practicable after award of the Contract, shall furnish in writing to the Owner, through the Architect, the names of subcontractors or suppliers for each portion of the Work. The Contractor shall not contract with any subcontractor or supplier to whom the Owner or Architect have made a timely and reasonable objection.

#### § 8.4 Labor and Materials

§ 8.4.1 Unless otherwise provided in the Contract Documents, the Contractor shall provide and pay for labor, materials, equipment, tools, utilities, transportation, and other facilities and services necessary for proper execution and completion of the Work.

§ 8.4.2 The Contractor shall enforce strict discipline and good order among the Contractor's employees and other persons carrying out the Contract Work. The Contractor shall not permit employment of unfit persons or persons not skilled in tasks assigned to them.

#### § 8.5 Warranty

The Contractor warrants to the Owner and Architect that: (1) materials and equipment furnished under the Contract will be new and of good quality unless otherwise required or permitted by the Contract Documents; (2) the Work will be free from defects not inherent in the quality required or permitted; and (3) the Work will conform to the requirements of the Contract Documents. Any material or equipment warranties required by the Contract Documents shall be issued in the name of the Owner, or shall be transferable to the Owner, and shall commence in accordance with Section 12.5.

#### § 8.6 Taxes

The Contractor shall pay sales, consumer, use, and similar taxes that are legally required when the Contract is executed.

#### § 8.7 Permits, Fees and Notices

§ 8.7.1 The Contractor shall obtain and pay for the building permit and other permits and governmental fees, licenses, and inspections necessary for proper execution and completion of the Work.

§ 8.7.2 The Contractor shall comply with and give notices required by agencies having jurisdiction over the Work. If the Contractor performs Work knowing it to be contrary to applicable laws, statutes, ordinances, codes, rules and regulations, or lawful orders of public authorities, the Contractor shall assume full responsibility for such Work and shall bear the attributable costs. The Contractor shall promptly notify the Architect in writing of any known inconsistencies in the Contract Documents with such governmental laws, rules, and regulations.

#### § 8.8 Submittals

The Contractor shall promptly review, approve in writing, and submit to the Architect shop drawings, product data, samples, and similar submittals required by the Contract Documents. Shop drawings, product data, samples, and similar submittals are not Contract Documents.

#### § 8.9 Use of Site

The Contractor shall confine operations at the site to areas permitted by law, ordinances, permits, the Contract Documents, and the Owner.

#### § 8.10 Cutting and Patching

The Contractor shall be responsible for cutting, fitting, or patching required to complete the Work or to make its parts fit together properly.

#### § 8.11 Cleaning Up

The Contractor shall keep the premises and surrounding area free from accumulation of debris and trash related to the Work. At the completion of the Work, the Contractor shall remove its tools, construction equipment, machinery, and surplus material; and shall properly dispose of waste materials.

#### § 8.12 Indemnification

To the fullest extent permitted by law, the Contractor shall indemnify and hold harmless the Owner, Architect, Architect's consultants, and agents and employees of any of them, from and against claims, damages, losses and expenses, including but not limited to attorneys' fees, arising out of or resulting from performance of the Work, provided that such claim, damage, loss, or expense is attributable to bodily injury, sickness, disease or death, or to injury to or destruction of tangible property (other than the Work itself), but only to the extent caused by the negligent acts or omissions of the Contractor, a subcontractor, anyone directly or indirectly employed by them or anyone for whose acts

they may be liable, regardless of whether or not such claim, damage, loss or expense is caused in part by a party indemnified hereunder.

#### **ARTICLE 9 ARCHITECT**

§ 9.1 The Architect will provide administration of the Contract as described in the Contract Documents. The Architect will have authority to act on behalf of the Owner only to the extent provided in the Contract Documents.

§ 9.2 The Architect will visit the site at intervals appropriate to the stage of construction to become generally familiar with the progress and quality of the Work.

§ 9.3 The Architect will not have control over or charge of, and will not be responsible for, construction means, methods, techniques, sequences, or procedures, or for safety precautions and programs in connection with the Work, since these are solely the Contractor's responsibility. The Architect will not be responsible for the Contractor's failure to carry out the Work in accordance with the Contract Documents.

§ 9.4 Based on the Architect's observations and evaluations of the Contractor's Applications for Payment, the Architect will review and certify the amounts due the Contractor.

§ 9.5 The Architect has authority to reject Work that does not conform to the Contract Documents.

§ 9.6 The Architect will promptly review and approve or take appropriate action upon Contractor's submittals, but only for the limited purpose of checking for conformance with information given and the design concept expressed in the Contract Documents.

§ 9.7 On written request from either the Owner or Contractor, the Architect will promptly interpret and decide matters concerning performance under, and requirements of, the Contract Documents.

§ 9.8 Interpretations and decisions of the Architect will be consistent with the intent of, and reasonably inferable from the Contract Documents, and will be in writing or in the form of drawings. When making such interpretations and decisions, the Architect will endeavor to secure faithful performance by both Owner and Contractor, will not show partiality to either and will not be liable for results of interpretations or decisions rendered in good faith.

§ 9.9 The Architect's duties, responsibilities, and limits of authority as described in the Contract Documents shall not be changed without written consent of the Owner, Contractor, and Architect. Consent shall not be unreasonably withheld.

#### **ARTICLE 10 CHANGES IN THE WORK**

§ 10.1 The Owner, without invalidating the Contract, may order changes in the Work within the general scope of the Contract, consisting of additions, deletions or other revisions, and the Contract Sum and Contract Time shall be adjusted accordingly, in writing. If the Owner and Contractor cannot agree to a change in the Contract Sum, the Owner shall pay the Contractor its actual cost plus reasonable overhead and profit.

§ 10.2 The Architect may authorize or order minor changes in the Work that are consistent with the intent of the Contract Documents and do not involve an adjustment in the Contract Sum or an extension of the Contract Time. Such authorization or order shall be in writing and shall be binding on the Owner and Contractor. The Contractor shall proceed with such minor changes promptly.

§ 10.3 If concealed or unknown physical conditions are encountered at the site that differ materially from those indicated in the Contract Documents or from those conditions ordinarily found to exist, the Contract Sum and Contract Time shall be subject to equitable adjustment.

#### **ARTICLE 11 TIME**

§ 11.1 Time limits stated in the Contract Documents are of the essence of the Contract.

§ 11.2 If the Contractor is delayed at any time in progress of the Work by changes ordered in the Work, or by labor disputes, fire, unusual delay in deliveries, unavoidable casualties, or other causes beyond the Contractor's control, the Contract Time shall be subject to equitable adjustment.

§ 11.3 Costs caused by delays or by improperly timed activities or defective construction shall be borne by the responsible party.

Init.

AIA Document A105™ – 2017. Copyright © 1993, 2007 and 2017 by The American Institute of Architects. All rights reserved. **WARNING: This AIA® Document is protected by U.S. Copyright Law and International Treaties. Unauthorized reproduction or distribution of this AIA® Document, or any portion of it, may result in severe civil and criminal penalties, and will be prosecuted to the maximum extent possible under the law.** To report copyright violations of AIA Contract Documents, e-mail The American Institute of Architects' legal counsel, [copyright@aia.org](mailto:copyright@aia.org).

## ARTICLE 12 PAYMENTS AND COMPLETION

### § 12.1 Contract Sum

The Contract Sum stated in this Agreement, including authorized adjustments, is the total amount payable by the Owner to the Contractor for performance of the Work under the Contract Documents.

### § 12.2 Applications for Payment

§ 12.2.1 At least ten days before the date established for each progress payment, the Contractor shall submit to the Architect an itemized Application for Payment for Work completed in accordance with the values stated in this Agreement. The Application shall be supported by data substantiating the Contractor's right to payment as the Owner or Architect may reasonably require, such as evidence of payments made to, and waivers of liens from, subcontractors and suppliers. Payments shall be made on account of materials and equipment delivered and suitably stored at the site for subsequent incorporation in the Work. If approved in advance by the Owner, payment may similarly be made for materials and equipment stored, and protected from damage, off the site at a location agreed upon in writing.

§ 12.2.2 The Contractor warrants that title to all Work covered by an Application for Payment will pass to the Owner no later than the time of payment. The Contractor further warrants that upon submittal of an Application for Payment, all Work for which Certificates for Payment have been previously issued and payments received from the Owner shall, to the best of the Contractor's knowledge, information, and belief, be free and clear of liens, claims, security interests, or other encumbrances adverse to the Owner's interests.

### § 12.3 Certificates for Payment

The Architect will, within seven days after receipt of the Contractor's Application for Payment, either (1) issue to the Owner a Certificate for Payment in the full amount of the Application for Payment, with a copy to the Contractor; (2) issue to the Owner a Certificate for Payment for such amount as the Architect determines is properly due, and notify the Contractor and Owner in writing of the Architect's reasons for withholding certification in part; or (3) withhold certification of the entire Application for Payment, and notify the Contractor and Owner of the Architect's reason for withholding certification in whole. If certification or notification is not made within such seven day period, the Contractor may, upon seven additional days' written notice to the Owner and Architect, stop the Work until payment of the amount owing has been received. The Contract Time and the Contract Sum shall be equitably adjusted due to the delay.

### § 12.4 Progress Payments

§ 12.4.1 After the Architect has issued a Certificate for Payment, the Owner shall make payment in the manner provided in the Contract Documents.

§ 12.4.2 The Contractor shall promptly pay each subcontractor and supplier, upon receipt of payment from the Owner, an amount determined in accordance with the terms of the applicable subcontracts and purchase orders.

§ 12.4.3 Neither the Owner nor the Architect shall have responsibility for payments to a subcontractor or supplier.

§ 12.4.4 A Certificate for Payment, a progress payment, or partial or entire use or occupancy of the Project by the Owner shall not constitute acceptance of Work not in accordance with the requirements of the Contract Documents.

### § 12.5 Substantial Completion

§ 12.5.1 Substantial Completion is the stage in the progress of the Work when the Work or designated portion thereof is sufficiently complete in accordance with the Contract Documents so the Owner can occupy or utilize the Work for its intended use.

§ 12.5.2 When the Contractor believes that the Work or designated portion thereof is substantially complete, it will notify the Architect and the Architect will make an inspection to determine whether the Work is substantially complete. When the Architect determines that the Work is substantially complete, the Architect shall prepare a Certificate of Substantial Completion that shall establish the date of Substantial Completion, establish the responsibilities of the Owner and Contractor, and fix the time within which the Contractor shall finish all items on the list accompanying the Certificate. Warranties required by the Contract Documents shall commence on the date of Substantial Completion of the Work or designated portion thereof unless otherwise provided in the Certificate of Substantial Completion.

## **§ 12.6 Final Completion and Final Payment**

**§ 12.6.1** Upon receipt of a final Application for Payment, the Architect will inspect the Work. When the Architect finds the Work acceptable and the Contract fully performed, the Architect will promptly issue a final Certificate for Payment.

**§ 12.6.2** Final payment shall not become due until the Contractor submits to the Architect releases and waivers of liens, and data establishing payment or satisfaction of obligations, such as receipts, claims, security interests, or encumbrances arising out of the Contract.

**§ 12.6.3** Acceptance of final payment by the Contractor, a subcontractor or supplier shall constitute a waiver of claims by that payee except those previously made in writing and identified by that payee as unsettled at the time of final Application for Payment.

## **ARTICLE 13 PROTECTION OF PERSONS AND PROPERTY**

The Contractor shall be responsible for initiating, maintaining and supervising all safety precautions and programs, including all those required by law in connection with performance of the Contract. The Contractor shall take reasonable precautions to prevent damage, injury, or loss to employees on the Work and other persons who may be affected thereby, the Work and materials and equipment to be incorporated therein, and other property at the site or adjacent thereto. The Contractor shall promptly remedy damage and loss to property caused in whole or in part by the Contractor, or by anyone for whose acts the Contractor may be liable.

## **ARTICLE 14 CORRECTION OF WORK**

**§ 14.1** The Contractor shall promptly correct Work rejected by the Architect as failing to conform to the requirements of the Contract Documents. The Contractor shall bear the cost of correcting such rejected Work, including the costs of uncovering, replacement, and additional testing.

**§ 14.2** In addition to the Contractor's other obligations including warranties under the Contract, the Contractor shall, for a period of one year after Substantial Completion, correct work not conforming to the requirements of the Contract Documents.

**§ 14.3** If the Contractor fails to correct nonconforming Work within a reasonable time, the Owner may correct it in accordance with Section 7.3.

## **ARTICLE 15 MISCELLANEOUS PROVISIONS**

### **§ 15.1 Assignment of Contract**

Neither party to the Contract shall assign the Contract as a whole without written consent of the other.

### **§ 15.2 Tests and Inspections**

**§ 15.2.1** At the appropriate times, the Contractor shall arrange and bear cost of tests, inspections, and approvals of portions of the Work required by the Contract Documents or by laws, statutes, ordinances, codes, rules and regulations, or lawful orders of public authorities.

**§ 15.2.2** If the Architect requires additional testing, the Contractor shall perform those tests.

**§ 15.2.3** The Owner shall bear cost of tests, inspections, or approvals that do not become requirements until after the Contract is executed. The Owner shall directly arrange and pay for tests, inspections, or approvals where building codes or applicable laws or regulations so require.

### **§ 15.3 Governing Law**

The Contract shall be governed by the law of the place where the Project is located, excluding that jurisdiction's choice of law rules.

## **ARTICLE 16 TERMINATION OF THE CONTRACT**

### **§ 16.1 Termination by the Contractor**

If the Work is stopped under Section 12.3 for a period of 14 days through no fault of the Contractor, the Contractor may, upon seven additional days' written notice to the Owner and Architect, terminate the Contract and recover from the Owner payment for Work executed including reasonable overhead and profit, and costs incurred by reason of such termination.



**§ 16.2 Termination by the Owner for Cause**

**§ 16.2.1** The Owner may terminate the Contract if the Contractor

- .1 repeatedly refuses or fails to supply enough properly skilled workers or proper materials;
- .2 fails to make payment to subcontractors for materials or labor in accordance with the respective agreements between the Contractor and the subcontractors;
- .3 repeatedly disregards applicable laws, statutes, ordinances, codes, rules and regulations, or lawful orders of a public authority; or
- .4 is otherwise guilty of substantial breach of a provision of the Contract Documents.

**§ 16.2.2** When any of the above reasons exist, the Owner, after consultation with the Architect, may without prejudice to any other rights or remedies of the Owner and after giving the Contractor and the Contractor's surety, if any, seven days' written notice, terminate employment of the Contractor and may

- .1 take possession of the site and of all materials thereon owned by the Contractor, and
- .2 finish the Work by whatever reasonable method the Owner may deem expedient.

**§ 16.2.3** When the Owner terminates the Contract for one of the reasons stated in Section 16.2.1, the Contractor shall not be entitled to receive further payment until the Work is finished.

**§ 16.2.4** If the unpaid balance of the Contract Sum exceeds costs of finishing the Work, such excess shall be paid to the Contractor. If such costs exceed the unpaid balance, the Contractor shall pay the difference to the Owner. This obligation for payment shall survive termination of the Contract.

**§ 16.3 Termination by the Owner for Convenience**

The Owner may, at any time, terminate the Contract for the Owner's convenience and without cause. The Contractor shall be entitled to receive payment for Work executed, and costs incurred by reason of such termination, along with reasonable overhead and profit on the Work not executed.

**ARTICLE 17 OTHER TERMS AND CONDITIONS**

*(Insert any other terms or conditions below.)*

This Agreement entered into as of the day and year first written above.

*(If required by law, insert cancellation period, disclosures or other warning statements above the signatures.)*

\_\_\_\_\_  
OWNER *(Signature)*

\_\_\_\_\_  
*(Printed name and title)*

\_\_\_\_\_  
CONTRACTOR *(Signature)*

\_\_\_\_\_  
*(Printed name and title)*

LICENSE NO.:  
JURISDICTION:



# AIA® Document A701™ – 2018

## **Instructions to Bidders**

for the following Project:  
*(Name, location, and detailed description)*

Repaving and Parking Lot Repairs for:  
Thunderbolt Career & Technology Center  
1069 Thunderbolt Drive  
Walterboro, SC 29488  
Colleton County Middle School  
1379 Tuskegee Airmen Drive  
Walterboro, SC 29488

**THE OWNER:**  
*(Name, legal status, address, and other information)*

Colleton County School District  
500 Forest Circle  
Walterboro, SC 29488

**THE ARCHITECT:**  
*(Name, legal status, address, and other information)*

The FWA Group, PA  
P.O. Box 5910  
Hilton Head Island, SC 29938

### **TABLE OF ARTICLES**

- |   |   |
|---|---|
| 1 | <b>DEFINITIONS</b>                                    |
| 2 | <b>BIDDER'S REPRESENTATIONS</b>                       |
| 3 | <b>BIDDING DOCUMENTS</b>                              |
| 4 | <b>BIDDING PROCEDURES</b>                             |
| 5 | <b>CONSIDERATION OF BIDS</b>                          |
| 6 | <b>POST-BID INFORMATION</b>                           |
| 7 | <b>PERFORMANCE BOND AND PAYMENT BOND</b>              |
| 8 | <b>ENUMERATION OF THE PROPOSED CONTRACT DOCUMENTS</b> |

**ADDITIONS AND DELETIONS:**  
The author of this document has added information needed for its completion. The author may also have revised the text of the original AIA standard form. An *Additions and Deletions Report* that notes added information as well as revisions to the standard form text is available from the author and should be reviewed. A vertical line in the left margin of this document indicates where the author has added necessary information and where the author has added to or deleted from the original AIA text.

This document has important legal consequences. Consultation with an attorney is encouraged with respect to its completion or modification.

**FEDERAL, STATE, AND LOCAL LAWS MAY IMPOSE REQUIREMENTS ON PUBLIC PROCUREMENT CONTRACTS. CONSULT LOCAL AUTHORITIES OR AN ATTORNEY TO VERIFY REQUIREMENTS APPLICABLE TO THIS PROCUREMENT BEFORE COMPLETING THIS FORM.**

It is intended that AIA Document G612™-2017, Owner's Instructions to the Architect, Parts A and B will be completed prior to using this document.

## ARTICLE 1 DEFINITIONS

§ 1.1 Bidding Documents include the Bidding Requirements and the Proposed Contract Documents. The Bidding Requirements consist of the advertisement or invitation to bid, Instructions to Bidders, supplementary instructions to bidders, the bid form, and any other bidding forms. The Proposed Contract Documents consist of the unexecuted form of Agreement between the Owner and Contractor and that Agreement's Exhibits, Conditions of the Contract (General, Supplementary and other Conditions), Drawings, Specifications, all Addenda, and all other documents enumerated in Article 8 of these Instructions.

§ 1.2 Definitions set forth in the General Conditions of the Contract for Construction, or in other Proposed Contract Documents apply to the Bidding Documents.

§ 1.3 Addenda are written or graphic instruments issued by the Architect, which, by additions, deletions, clarifications, or corrections, modify or interpret the Bidding Documents.

§ 1.4 A Bid is a complete and properly executed proposal to do the Work for the sums stipulated therein, submitted in accordance with the Bidding Documents.

§ 1.5 The Base Bid is the sum stated in the Bid for which the Bidder offers to perform the Work described in the Bidding Documents, to which Work may be added or deleted by sums stated in Alternate Bids.

§ 1.6 An Alternate Bid (or Alternate) is an amount stated in the Bid to be added to or deducted from, or that does not change, the Base Bid if the corresponding change in the Work, as described in the Bidding Documents, is accepted.

§ 1.7 A Unit Price is an amount stated in the Bid as a price per unit of measurement for materials, equipment, or services, or a portion of the Work, as described in the Bidding Documents.

§ 1.8 A Bidder is a person or entity who submits a Bid and who meets the requirements set forth in the Bidding Documents.

§ 1.9 A Sub-bidder is a person or entity who submits a bid to a Bidder for materials, equipment, or labor for a portion of the Work.

## ARTICLE 2 BIDDER'S REPRESENTATIONS

§ 2.1 By submitting a Bid, the Bidder represents that:

- .1 the Bidder has read and understands the Bidding Documents;
- .2 the Bidder understands how the Bidding Documents relate to other portions of the Project, if any, being bid concurrently or presently under construction;
- .3 the Bid complies with the Bidding Documents;
- .4 the Bidder has visited the site, become familiar with local conditions under which the Work is to be performed, and has correlated the Bidder's observations with the requirements of the Proposed Contract Documents;
- .5 the Bid is based upon the materials, equipment, and systems required by the Bidding Documents without exception; and
- .6 the Bidder has read and understands the provisions for liquidated damages, if any, set forth in the form of Agreement between the Owner and Contractor.

## ARTICLE 3 BIDDING DOCUMENTS

### § 3.1 Distribution

§ 3.1.1 Bidders shall obtain complete Bidding Documents, as indicated below, from the issuing office designated in the advertisement or invitation to bid, for the deposit sum, if any, stated therein.

*(Indicate how, such as by email, website, hosi site/platform, paper copy, or other method Bidders shall obtain Bidding Documents.)*

§ 3.1.2 Any required deposit shall be refunded to Bidders who submit a bona fide Bid and return the paper Bidding Documents in good condition within ten days after receipt of Bids. The cost to replace missing or damaged paper documents will be deducted from the deposit. A Bidder receiving a Contract award may retain the paper Bidding Documents, and the Bidder's deposit will be refunded.

§ 3.1.3 Bidding Documents will not be issued directly to Sub-bidders unless specifically offered in the advertisement or invitation to bid, or in supplementary instructions to bidders.

§ 3.1.4 Bidders shall use complete Bidding Documents in preparing Bids. Neither the Owner nor Architect assumes responsibility for errors or misinterpretations resulting from the use of incomplete Bidding Documents.

§ 3.1.5 The Bidding Documents will be available for the sole purpose of obtaining Bids on the Work. No license or grant of use is conferred by distribution of the Bidding Documents.

### § 3.2 Modification or Interpretation of Bidding Documents

§ 3.2.1 The Bidder shall carefully study the Bidding Documents, shall examine the site and local conditions, and shall notify the Architect of errors, inconsistencies, or ambiguities discovered and request clarification or interpretation pursuant to Section 3.2.2.

§ 3.2.2 Requests for clarification or interpretation of the Bidding Documents shall be submitted by the Bidder in writing and shall be received by the Architect at least seven days prior to the date for receipt of Bids.  
*(Indicate how, such as by email, website, host site/platform, paper copy, or other method Bidders shall submit requests for clarification and interpretation.)*

§ 3.2.3 Modifications and interpretations of the Bidding Documents shall be made by Addendum. Modifications and interpretations of the Bidding Documents made in any other manner shall not be binding, and Bidders shall not rely upon them.

### § 3.3 Substitutions

§ 3.3.1 The materials, products, and equipment described in the Bidding Documents establish a standard of required function, dimension, appearance, and quality to be met by any proposed substitution.

#### § 3.3.2 Substitution Process

§ 3.3.2.1 Written requests for substitutions shall be received by the Architect at least ten days prior to the date for receipt of Bids. Requests shall be submitted in the same manner as that established for submitting clarifications and interpretations in Section 3.2.2.

§ 3.3.2.2 Bidders shall submit substitution requests on a Substitution Request Form if one is provided in the Bidding Documents.

§ 3.3.2.3 If a Substitution Request Form is not provided, requests shall include (1) the name of the material or equipment specified in the Bidding Documents; (2) the reason for the requested substitution; (3) a complete description of the proposed substitution including the name of the material or equipment proposed as the substitute, performance and test data, and relevant drawings; and (4) any other information necessary for an evaluation. The request shall include a statement setting forth changes in other materials, equipment, or other portions of the Work, including changes in the work of other contracts or the impact on any Project Certifications (such as LEED), that will result from incorporation of the proposed substitution.

§ 3.3.3 The burden of proof of the merit of the proposed substitution is upon the proposer. The Architect's decision of approval or disapproval of a proposed substitution shall be final.

§ 3.3.4 If the Architect approves a proposed substitution prior to receipt of Bids, such approval shall be set forth in an Addendum. Approvals made in any other manner shall not be binding, and Bidders shall not rely upon them.

§ 3.3.5 No substitutions will be considered after the Contract award unless specifically provided for in the Contract Documents.

**§ 3.4 Addenda**

§ 3.4.1 Addenda will be transmitted to Bidders known by the issuing office to have received complete Bidding Documents.

*(Indicate how, such as by email, website, host site/platform, paper copy, or other method Addenda will be transmitted.)*

§ 3.4.2 Addenda will be available where Bidding Documents are on file.

§ 3.4.3 Addenda will be issued no later than four days prior to the date for receipt of Bids, except an Addendum withdrawing the request for Bids or one which includes postponement of the date for receipt of Bids.

§ 3.4.4 Prior to submitting a Bid, each Bidder shall ascertain that the Bidder has received all Addenda issued, and the Bidder shall acknowledge their receipt in the Bid.

**ARTICLE 4 BIDDING PROCEDURES**

**§ 4.1 Preparation of Bids**

§ 4.1.1 Bids shall be submitted on the forms included with or identified in the Bidding Documents.

§ 4.1.2 All blanks on the bid form shall be legibly executed. Paper bid forms shall be executed in a non-erasable medium.

§ 4.1.3 Sums shall be expressed in both words and numbers, unless noted otherwise on the bid form. In case of discrepancy, the amount entered in words shall govern.

§ 4.1.4 Edits to entries made on paper bid forms must be initialed by the signer of the Bid.

§ 4.1.5 All requested Alternates shall be bid. If no change in the Base Bid is required, enter "No Change" or as required by the bid form.

§ 4.1.6 Where two or more Bids for designated portions of the Work have been requested, the Bidder may, without forfeiture of the bid security, state the Bidder's refusal to accept award of less than the combination of Bids stipulated by the Bidder. The Bidder shall neither make additional stipulations on the bid form nor qualify the Bid in any other manner.

§ 4.1.7 Each copy of the Bid shall state the legal name and legal status of the Bidder. As part of the documentation submitted with the Bid, the Bidder shall provide evidence of its legal authority to perform the Work in the jurisdiction where the Project is located. Each copy of the Bid shall be signed by the person or persons legally authorized to bind the Bidder to a contract. A Bid by a corporation shall further name the state of incorporation and have the corporate seal affixed. A Bid submitted by an agent shall have a current power of attorney attached, certifying the agent's authority to bind the Bidder.

§ 4.1.8 A Bidder shall incur all costs associated with the preparation of its Bid.

**§ 4.2 Bid Security**

§ 4.2.1 Each Bid shall be accompanied by the following bid security:

*(Insert the form and amount of bid security.)*

§ 4.2.2 The Bidder pledges to enter into a Contract with the Owner on the terms stated in the Bid and shall, if required, furnish bonds covering the faithful performance of the Contract and payment of all obligations arising thereunder. Should the Bidder refuse to enter into such Contract or fail to furnish such bonds if required, the amount of the bid security shall be forfeited to the Owner as liquidated damages, not as a penalty. In the event the Owner fails to comply with Section 6.2, the amount of the bid security shall not be forfeited to the Owner.

§ 4.2.3 If a surety bond is required as bid security, it shall be written on AIA Document A310™, Bid Bond, unless otherwise provided in the Bidding Documents. The attorney-in-fact who executes the bond on behalf of the surety shall affix to the bond a certified and current copy of an acceptable power of attorney. The Bidder shall provide surety bonds from a company or companies lawfully authorized to issue surety bonds in the jurisdiction where the Project is located.

§ 4.2.4 The Owner will have the right to retain the bid security of Bidders to whom an award is being considered until (a) the Contract has been executed and bonds, if required, have been furnished; (b) the specified time has elapsed so that Bids may be withdrawn; or (c) all Bids have been rejected. However, if no Contract has been awarded or a Bidder has not been notified of the acceptance of its Bid, a Bidder may, beginning days after the opening of Bids, withdraw its Bid and request the return of its bid security.

#### § 4.3 Submission of Bids

§ 4.3.1 A Bidder shall submit its Bid as indicated below:

*(Indicate how, such as by website, host site/platform, paper copy, or other method Bidders shall submit their Bid.)*

§ 4.3.2 Paper copies of the Bid, the bid security, and any other documents required to be submitted with the Bid shall be enclosed in a sealed opaque envelope. The envelope shall be addressed to the party receiving the Bids and shall be identified with the Project name, the Bidder's name and address, and, if applicable, the designated portion of the Work for which the Bid is submitted. If the Bid is sent by mail, the sealed envelope shall be enclosed in a separate mailing envelope with the notation "SEALED BID ENCLOSED" on the face thereof.

§ 4.3.3 Bids shall be submitted by the date and time and at the place indicated in the invitation to bid. Bids submitted after the date and time for receipt of Bids, or at an incorrect place, will not be accepted.

§ 4.3.4 The Bidder shall assume full responsibility for timely delivery at the location designated for receipt of Bids.

§ 4.3.5 A Bid submitted by any method other than as provided in this Section 4.3 will not be accepted.

#### § 4.4 Modification or Withdrawal of Bid

§ 4.4.1 Prior to the date and time designated for receipt of Bids, a Bidder may submit a new Bid to replace a Bid previously submitted, or withdraw its Bid entirely, by notice to the party designated to receive the Bids. Such notice shall be received and duly recorded by the receiving party on or before the date and time set for receipt of Bids. The receiving party shall verify that replaced or withdrawn Bids are removed from the other submitted Bids and not considered. Notice of submission of a replacement Bid or withdrawal of a Bid shall be worded so as not to reveal the amount of the original Bid.

§ 4.4.2 Withdrawn Bids may be resubmitted up to the date and time designated for the receipt of Bids in the same format as that established in Section 4.3, provided they fully conform with these Instructions to Bidders. Bid security shall be in an amount sufficient for the Bid as resubmitted.

§ 4.4.3 After the date and time designated for receipt of Bids, a Bidder who discovers that it made a clerical error in its Bid shall notify the Architect of such error within two days, or pursuant to a timeframe specified by the law of the jurisdiction where the Project is located, requesting withdrawal of its Bid. Upon providing evidence of such error to the reasonable satisfaction of the Architect, the Bid shall be withdrawn and not resubmitted. If a Bid is withdrawn pursuant to this Section 4.4.3, the bid security will be attended to as follows:

*(State the terms and conditions, such as Bid rank, for returning or retaining the bid security.)*

### ARTICLE 5 CONSIDERATION OF BIDS

#### § 5.1 Opening of Bids

If stipulated in an advertisement or invitation to bid, or when otherwise required by law, Bids properly identified and received within the specified time limits will be publicly opened and read aloud. A summary of the Bids may be made available to Bidders.

## **§ 5.2 Rejection of Bids**

Unless otherwise prohibited by law, the Owner shall have the right to reject any or all Bids.

## **§ 5.3 Acceptance of Bid (Award)**

**§ 5.3.1** It is the intent of the Owner to award a Contract to the lowest responsive and responsible Bidder, provided the Bid has been submitted in accordance with the requirements of the Bidding Documents. Unless otherwise prohibited by law, the Owner shall have the right to waive informalities and irregularities in a Bid received and to accept the Bid which, in the Owner's judgment, is in the Owner's best interests.

**§ 5.3.2** Unless otherwise prohibited by law, the Owner shall have the right to accept Alternates in any order or combination, unless otherwise specifically provided in the Bidding Documents, and to determine the lowest responsive and responsible Bidder on the basis of the sum of the Base Bid and Alternates accepted.

## **ARTICLE 6 POST-BID INFORMATION**

### **§ 6.1 Contractor's Qualification Statement**

Bidders to whom award of a Contract is under consideration shall submit to the Architect, upon request and within the timeframe specified by the Architect, a properly executed AIA Document A305™, Contractor's Qualification Statement, unless such a Statement has been previously required and submitted for this Bid.

### **§ 6.2 Owner's Financial Capability**

A Bidder to whom award of a Contract is under consideration may request in writing, fourteen days prior to the expiration of the time for withdrawal of Bids, that the Owner furnish to the Bidder reasonable evidence that financial arrangements have been made to fulfill the Owner's obligations under the Contract. The Owner shall then furnish such reasonable evidence to the Bidder no later than seven days prior to the expiration of the time for withdrawal of Bids. Unless such reasonable evidence is furnished within the allotted time, the Bidder will not be required to execute the Agreement between the Owner and Contractor.

### **§ 6.3 Submittals**

**§ 6.3.1** After notification of selection for the award of the Contract, the Bidder shall, as soon as practicable or as stipulated in the Bidding Documents, submit in writing to the Owner through the Architect:

- .1 a designation of the Work to be performed with the Bidder's own forces;
- .2 names of the principal products and systems proposed for the Work and the manufacturers and suppliers of each; and
- .3 names of persons or entities (including those who are to furnish materials or equipment fabricated to a special design) proposed for the principal portions of the Work.

**§ 6.3.2** The Bidder will be required to establish to the satisfaction of the Architect and Owner the reliability and responsibility of the persons or entities proposed to furnish and perform the Work described in the Bidding Documents.

**§ 6.3.3** Prior to the execution of the Contract, the Architect will notify the Bidder if either the Owner or Architect, after due investigation, has reasonable objection to a person or entity proposed by the Bidder. If the Owner or Architect has reasonable objection to a proposed person or entity, the Bidder may, at the Bidder's option, withdraw the Bid or submit an acceptable substitute person or entity. The Bidder may also submit any required adjustment in the Base Bid or Alternate Bid to account for the difference in cost occasioned by such substitution. The Owner may accept the adjusted bid price or disqualify the Bidder. In the event of either withdrawal or disqualification, bid security will not be forfeited.

**§ 6.3.4** Persons and entities proposed by the Bidder and to whom the Owner and Architect have made no reasonable objection must be used on the Work for which they were proposed and shall not be changed except with the written consent of the Owner and Architect.

## **ARTICLE 7 PERFORMANCE BOND AND PAYMENT BOND**

### **§ 7.1 Bond Requirements**

**§ 7.1.1** If stipulated in the Bidding Documents, the Bidder shall furnish bonds covering the faithful performance of the Contract and payment of all obligations arising thereunder.

§ 7.1.2 If the furnishing of such bonds is stipulated in the Bidding Documents, the cost shall be included in the Bid. If the furnishing of such bonds is required after receipt of bids and before execution of the Contract, the cost of such bonds shall be added to the Bid in determining the Contract Sum.

§ 7.1.3 The Bidder shall provide surety bonds from a company or companies lawfully authorized to issue surety bonds in the jurisdiction where the Project is located.

§ 7.1.4 Unless otherwise indicated below, the Penal Sum of the Payment and Performance Bonds shall be the amount of the Contract Sum.

*(If Payment or Performance Bonds are to be in an amount other than 100% of the Contract Sum, indicate the dollar amount or percentage of the Contract Sum.)*

## § 7.2 Time of Delivery and Form of Bonds

§ 7.2.1 The Bidder shall deliver the required bonds to the Owner not later than three days following the date of execution of the Contract. If the Work is to commence sooner in response to a letter of intent, the Bidder shall, prior to commencement of the Work, submit evidence satisfactory to the Owner that such bonds will be furnished and delivered in accordance with this Section 7.2.1.

§ 7.2.2 Unless otherwise provided, the bonds shall be written on AIA Document A312, Performance Bond and Payment Bond.

§ 7.2.3 The bonds shall be dated on or after the date of the Contract.

§ 7.2.4 The Bidder shall require the attorney-in-fact who executes the required bonds on behalf of the surety to affix to the bond a certified and current copy of the power of attorney.

## ARTICLE 8 ENUMERATION OF THE PROPOSED CONTRACT DOCUMENTS

§ 8.1 Copies of the proposed Contract Documents have been made available to the Bidder and consist of the following documents:

- .1 AIA Document A101™–2017, Standard Form of Agreement Between Owner and Contractor, unless otherwise stated below.  
*(Insert the complete AIA Document number, including year, and Document title.)*
  
- .2 AIA Document A101™–2017, Exhibit A, Insurance and Bonds, unless otherwise stated below.  
*(Insert the complete AIA Document number, including year, and Document title.)*
  
- .3 AIA Document A201™–2017, General Conditions of the Contract for Construction, unless otherwise stated below.  
*(Insert the complete AIA Document number, including year, and Document title.)*
  
- .4 AIA Document E203™–2013, Building Information Modeling and Digital Data Exhibit, dated as indicated below:  
*(Insert the date of the E203-2013.)*
  
- .5 Drawings



- | Number | Title   | Date         |                          |
|--------|---|--------------|--------------------------|
| .6     | Specifications  |              |                          |
|        | <b>Section</b>  | <b>Title</b> | <b>Date</b> <b>Pages</b> |
| .7     | Addenda:  |              |                          |
|        | <b>Number</b>   | <b>Date</b>  | <b>Pages</b>             |
| .8     | Other Exhibits:<br><i>(Check all boxes that apply and include appropriate information identifying the exhibit where required.)</i>                      |              |                          |
|        | <input type="checkbox"/> AIA Document E204™–2017, Sustainable Projects Exhibit, dated as indicated below:<br><i>(Insert the date of the E204-2017.)</i> |              |                          |
|        | <input type="checkbox"/> The Sustainability Plan:   |              |                          |
|        | <b>Title</b>  | <b>Date</b>  | <b>Pages</b>             |
|        | <input type="checkbox"/> Supplementary and other Conditions of the Contract:  |              |                          |
|        | <b>Document</b>   | <b>Title</b> | <b>Date</b> <b>Pages</b> |
| .9     | Other documents listed below:<br><i>(List here any additional documents that are intended to form part of the Proposed Contract Documents.)</i>         |              |                          |

**SECTION 00 5502**  
**SUPPLEMENTAL INSTRUCTIONS TO BIDDERS AIA A701-2018**

**1. SUPPLEMENTAL INSTRUCTIONS TO BIDDERS**

1.1. These Standard Supplemental Instructions to Bidders amend or supplement Instructions to Bidders (AIA Document A701-2018) and other provisions of Bidding and Contract Documents as indicated below.

1.2. All provisions of A701-2018, which are not so amended or supplemented, remain in full force and effect.

1.4. Bidders are cautioned to carefully examine the Bidding and Contract Documents for additional instructions or requirements.

**2. MODIFICATIONS TO A701-2018**

2.1. Delete Section 1.1 and insert the following:

“1.1 Bidding Documents collectively referred to as the Invitation for Bids; include the Bidding Requirements and the proposed Contract Documents. The Bidding Requirements consist of the Advertisement, Instructions to Bidders (A-701), Supplementary Instructions to Bidders, and the Proposal Form. The proposed Contract Documents consist of the form Supplementary of Agreement between the Owner and Contractor, Conditions of the Contract (General and other Conditions), Drawings, Specifications, all Addenda issued prior to execution of the Contract, and other documents set forth in the Bidding Documents. Any reference in this document to the Agreement between the Owner and Contractor, AIA Document A105, or some abbreviated reference thereof, shall mean the AIA A105-2017 Edition.”

2.2. In Section 1.8, delete the words “and who meets the requirements set forth in the Bidding Documents”.

2.3. In Section 2.1.1, insert the following before the semicolon at the end:

“. Bidders are expected to examine the Bidding Documents and Contract Documents thoroughly and should request an explanation of any ambiguities, discrepancies, errors, omissions, or conflicting statements. Failure to do so will be at the Bidder’s risk. Bidder assumes responsibility for any patent ambiguity that Bidder does not bring to the Owner’s attention prior to bid opening”

2.4. In Section 2.1.3, insert the following after the term “Bidding Documents” and before the semicolon:

“and accepts full responsibility for any pre-bid existing conditions that would affect the Bid that could have been ascertained by a site visit”

2.5. Insert the following Sections 2.2 through 2.6:

“2.2 Certification of Independent Price Determination

GIVING FALSE, MISLEADING, OR INCOMPLETE INFORMATION ON THIS CERTIFICATION MAY RENDER YOU SUBJECT TO PROSECUTION UNDER SECTION 16-9-10 OF THE SOUTH CAROLINA CODE OF LAWS AND OTHER APPLICABLE LAWS.

(a) By submitting a bid, the bidder certifies that—

(1) The prices in this bid have been arrived at independently, without, for the purpose of restricting competition, any consultation, communication, or agreement with any other bidder or competitor relating to—

- (i) Those prices;
- (ii) The intention to submit a bid; or
- (iii) The methods or factors used to calculate the prices offered.

(2) The prices in this bid have not been and will not be knowingly disclosed by the bidder, directly or indirectly, to any other bidder or competitor before bid opening (in the case of a sealed bid solicitation) or contract award (in the case of a negotiated solicitation) unless otherwise required by law; and

(3) No attempt has been made or will be made by the bidder to induce any other concern to submit or not to submit a bid for the purpose of restricting competition.

(b) Each signature on the bid is considered to be a certification by the signatory that the signatory:

(1) Is the person in the bidder's organization responsible for determining the prices being offered in this bid, and that the signatory has not participated and will not participate in any action contrary to paragraphs (a)(1) through (a)(3) of this certification; or

(2)(i) Has been authorized, in writing, to act as agent for the bidder's principals in certifying that those principals have not participated, and will not participate in any action contrary to paragraphs (a) (1) through (a) (3) of this certification [As used in this subdivision (b) (2) (i), the term "principals" means the person(s) in the bidder's organization responsible for determining the prices offered in this bid];

(ii) As an authorized agent, does certify that the principals referenced in subdivision (b)(2)(i) of this certification have not participated, and will not participate, in any action contrary to paragraphs (a)(1) through (a)(3) of this certification; and

(iii) As an agent, has not personally participated, and will not participate, in any action contrary to paragraphs (a)(1) through (a)(3) of this certification.

(c) If the bidder deletes or modifies paragraph (a) (2) of this certification, the bidder must furnish with its offer a signed statement setting forth in detail the circumstances of the disclosure.

### 2.3 Drug Free Workplace

By submitting a bid, the Bidder certifies that Bidder will maintain a drug free workplace in accordance with the requirements of Title 44, Chapter 107 of South Carolina Code of Laws, as amended.

### 2.4 CERTIFICATION REGARDING DEBARMENT AND OTHER RESPONSIBILITY MATTERS

(a) (1) By submitting a Bid, Bidder certifies, to the best of its knowledge and belief, that-

(i) Bidder and/or any of its Principals-

(A) Are not presently debarred, suspended, proposed for debarment, or declared ineligible for the award of contracts by any state or federal agency;

(B) Have not, within a three-year period preceding this bid, been convicted of or had a civil judgment rendered against them for: commission of fraud or a criminal offense in connection with obtaining, attempting to obtain, or performing a public (Federal, state, or local) contract or subcontract; violation of Federal or state antitrust statutes relating to the submission of bids; or commission of embezzlement, theft, forgery, bribery, falsification or destruction of records, making false statements, tax evasion, or receiving stolen property; and

(C) Are not presently indicted for, or otherwise criminally or civilly charged by a governmental entity with, commission of any of the offenses enumerated in paragraph (a)(1)(i)(B) of this provision.

(ii) Bidder has not, within a three-year period preceding this bid, had one or more contracts terminated for default by any public (Federal, state, or local) entity.

(2) "Principals," for the purposes of this certification, means officers; directors; owners; partners; and persons having primary management or supervisory responsibilities within a business entity (e.g., general manager; plant manager; head of a subsidiary, division, or business segment, and similar positions).

(b) Bidder shall provide immediate written notice to the Procurement Officer if, at any time prior to contract award, Bidder learns that its certification was erroneous when submitted or has become erroneous by reason of changed circumstances.

(c) If Bidder is unable to certify the representations stated in paragraphs (a) (1), Bid must submit a written explanation regarding its inability to make the certification. The certification will be considered in connection with a review of the Bidder's responsibility. Failure of the Bidder to furnish additional information as requested by the Procurement Officer may render the Bidder non-responsible.

(d) Nothing contained in the foregoing shall be construed to require establishment of a system of records in order to render, in good faith, the certification required by paragraph (a) of this provision. The knowledge and information of a Bidder is not required to exceed that which is normally possessed by a prudent person in the ordinary course of business dealings.

(e) The certification in paragraph (a) of this provision is a material representation of fact upon which reliance was placed when making award. If it is later determined that the Bidder knowingly or in bad faith rendered an erroneous certification, in addition to other remedies available to the State, the Procurement Officer may terminate the contract resulting from this solicitation for default.

## 2.5 ETHICS CERTIFICATE

By submitting a bid, the bidder certifies that the bidder has and will comply with, and has not, and will not, induce a person to violate Title 8, Chapter 13 of the South Carolina Code of Laws, as amended (ethics act). The following statutes require special attention: Section 8-13-700, regarding use of official position for financial gain; Section 8-13-705, regarding gifts to influence action of public official; Section 8-13-720, regarding offering money for advice or assistance of public official; Sections 8-13-755 and 8-13-760, regarding restrictions on employment by former public official; Section 8-13-775, prohibiting public official with economic interests from acting on contracts; Section 8-13-790, regarding recovery of kickbacks; Section 8-13-1150, regarding statements to be filed by consultants; and Section 8-13-1342, regarding restrictions on contributions by contractor to candidate who participated in awarding of contract. The state may rescind any contract and recover all amounts expended as a result of any action taken in violation of this provision. If contractor participates, directly or indirectly, in the evaluation or award of public contracts, including without limitation, change orders or task orders regarding a public contract, contractor shall, if required by law to file such a statement, provide the statement required by Section 8-13-1150 to the procurement officer at the same time the law requires the statement to be filed.

## 2.6 RESTRICTIONS APPLICABLE TO BIDDERS & GIFTS

Violation of these restrictions may result in disqualification of your bid, suspension or debarment, and may constitute a violation of the state Ethics Act. (a) After issuance of the solicitation, bidder agrees not to discuss this procurement activity in any way with the Owner or its employees, agents or officials. All communications must be solely with the Procurement Officer. This restriction may be

lifted by express written permission from the Procurement Officer. This restriction expires once a contract has been formed. (b) Unless otherwise approved in writing by the Procurement Officer, bidder agrees not to give anything to the Owner, any affiliated organizations, or the employees, agents or officials of either, prior to award."

2.6. Delete Section 3.1.1 and substitute the following:

"3.1.1 Bidders may obtain electronic versions of the Bidding Documents from the Architect as directed by Colleton County School District."

2.7. Delete the language of Section 3.1.2 and insert the word "Reserved."

2.8. In Section 3.2.2:

After Architect delete "at least seven" and replace with "at least ten"

2.9. In Section 3.2.3:

In the first Sentence, insert the word "written" before the word "Addendum."

2.10. Insert the following at the end of Section 3.3.1:

"Reference in the Bidding Documents to a designated material, product, thing, or service by specific brand or trade name followed by the words "or equal" and "or approved equal" shall be interpreted as establishing a standard of quality and shall not be construed as limiting competition."

2.11. Delete Section 3.3.2 and substitute the following:

"3.3.2 No request to substitute materials, products, or equipment for materials, products, or equipment described in the Bidding Documents and no request for addition of a manufacturer or supplier to a list of approved manufacturers or suppliers in the Bidding Documents will be considered prior to receipt of Bids unless written request for approval has been received by the Architect at least ten days prior to the date for receipt of Bids established in the Invitation for Bids. Any subsequent extension of the date for receipt of Bids by addendum shall not extend the date for receipt of such requests unless the addendum so specifies. Such requests shall include the name of the material or equipment for which it is to be substituted and a complete description of the proposed substitution including drawings, performance and test data, and other information necessary for an evaluation. A statement setting forth changes in other materials, equipment, or other portions of the Work, including changes in the work of other contracts that incorporation of the proposed substitution would require, shall be included. The burden of proof of the merit of the proposed substitution is upon the proposer. The Architect's decision of approval or disapproval of a proposed substitution shall be final."

2.12. Delete Section 3.4.3 and substitute the following:

"3.4.3 Addenda will be issued no later than five days prior to the time for receipt of Bids except an Addendum withdrawing the request for Bids or one which includes postponement of the date for receipt of Bids."

2.13. Insert the following Section 3.4.5:

"3.4.5 When the date for receipt of Bids is to be postponed and there is insufficient time to issue a written Addendum prior to the original Bid Date, Owner will notify prospective Bidders by telephone or other appropriate means with immediate follow up with a written Addendum. This Addendum will verify the postponement of the original Bid Date and establish a new Bid Date. The new Bid Date will

be no earlier than the fifth (5th) calendar day after the date of issuance of the Addendum postponing the original Bid Date.”

2.14. Delete Section 4.1.2 and substitute the following:

“4.1.2 Any blanks on the bid form to be filled in by the Bidder shall be legibly executed in a non-erasable medium. Bids shall be signed in ink or other indelible media.”

2.15. Insert the following at the end of Section 4.1.4:

“Bidder shall not make stipulations or qualify his bid in any manner not permitted on the proposal form. An incomplete Bid or information not requested that is written on or attached to the Proposal Form that could be considered a qualification of the Bid, may be cause for rejection of the Bid.”

2.16. Delete Section 4.1.5 and substitute the following:

“4.1.5 All requested Alternates, if any, shall be bid. The failure of the bidder to indicate a price for an Alternate shall render the Bid non-responsive. Indicate the change to the Base Bid by entering the dollar amount and marking, as appropriate, the box for “ADD TO” or “DEDUCT FROM”. If no change in the Base Bid is required, enter “zero” or “No Change.” For add alternates to the base bid, Subcontractor(s) listed on the Proposal Form to perform Alternate Work shall be used for both Alternates and Base Bid Work if Alternates are accepted.”

2.17. Delete Section 4.2.1 and substitute the following:

“4.2.1 The requirements for bid security are stipulated in “Division 32 – Exterior Improvements under Section A.3. Proposal Section and Section B.3. Proposal Section.”

2.18. Delete Section 4.3.1 and substitute the following:

“4.3.1 All copies of the Bid and any other documents required to be submitted with the Bid shall be enclosed in a sealed opaque envelope. The envelope shall, unless hand delivered by the Bidder, be addressed to the Owner’s designated purchasing office as shown in the Invitation for Bids. The envelope shall be identified with the Project name, the Bidder’s name and address and, if applicable, the designated portion of the Work for which the Bid is submitted. If the Bid is sent by mail or special delivery service (UPS, Federal Express, etc.), the envelope should be labeled “BID ENCLOSED” on the face thereof. Bidders’ hand delivering their Bids shall deliver Bids to the place of the Bid Opening as shown in the Invitation for Bids. Whether or not Bidders attend the Bid Opening, they shall give their Bids to the Owner’s procurement officer or his/her designee as shown in the Invitation for Bids prior to the time of the Bid Opening.”

2.19. Delete the language of Section 4.3.2 and insert the word “Reserved.”

2.20. Delete Section 4.3.5 and substitute the following:

“4.3.5 The official time for receipt of Bids will be determined by reference to the clock designated by the Owner or his/her designee. The procurement officer conducting the Bid Opening will determine and announce that the deadline has arrived and no further Bids or bid modifications will be accepted. All Bids and bid modifications in the possession of the procurement officer at the time the announcement is completed will be timely, whether or not the bid envelope has been date/time stamped or otherwise marked by the procurement officer.”

2.21. Delete Section 4.4.2 and substitute the following:

"4.4.2 Prior to the time and date designated for receipt of Bids, a Bid submitted may be withdrawn in person or by written notice to the party receiving Bids at the place designated for receipt of Bids. Withdrawal by written notice shall be in writing over the signature of the Bidder."

2.22. In Section 4.4.3 add the following:

In the second sentence after "Architect" add "and Owner".

At the end of Section 4.4.3 add "Owner will determine if the bid security is to be retained or returned."

2.23. In Section 5.1, delete everything following the caption "OPENING OF BIDS" and substitute the following:

"5.1.1 Bids received on time will be publically opened.

5.1.2 Owner will send a copy of the final Bid Tabulation to all Bidders within ten (10) working days of the Bid Opening.

5.1.3 If Owner determines to award the Project, Owner will send a Notice of Award to all Bidders.

5.1.4 If only one Bid is received, Owner will not open or consider the Bid.

5.1.5 If two Bids are received, Owner will open or consider the Bids."

2.24. In Section 5.2, insert the section number "5.2.1" before the words of the "Unless otherwise" at the beginning of the sentence.

2.25. Insert the following Sections 5.2.2 and 5.2.3:

"5.2.2 The reasons for which the Owner will reject Bids include, but are not limited to:

- .1 Failure to deliver the Bid on time;
- .2 Failure to Bid an Alternate, except as expressly allowed by law;
- .3 Showing any material modification(s) or exception(s) qualifying the Bid;
- .4 Faxing a Bid directly to the Owner or their representative; or
- .5 Failure to include a properly executed Power-of-Attorney with the bid bond.

5.2.3 The Owner may reject a Bid as nonresponsive if the prices bid are materially unbalanced between line items or sub-line items. A bid is materially unbalanced when it is based on prices significantly less than cost for some work and prices which are significantly overstated in relation to cost for other work, and if there is a reasonable doubt that the bid will result in the lowest overall cost to the Owner even though it may be the low evaluated bid, or if it is so unbalanced as to be tantamount to allowing an advance payment."

2.26. Delete Section 6.1 and substitute the following:

#### **"6.1 CONTRACTOR'S RESPONSIBILITY**

Owner will make a determination of Bidder's responsibility before awarding a contract. Bidder shall provide all information and documentation requested by the Owner to support the Owner's evaluation of responsibility. Failure of Bidder to provide requested information is cause for the Owner, at its option, to determine the Bidder to be non-responsible."

2.27. Delete the language of Section 6.2 and insert the word "Reserved."

2.28. Delete the language of Sections 6.3.2 and 6.3.3 and insert the word "Reserved" after each Section Number.

2.29. Insert the following Section 6.4

**"6.4 CLARIFICATION**

The Procurement Officer may elect to communicate with a Bidder after opening for the purpose of clarifying either the Bid or the requirements of the Invitation for Bids. Such communications may be conducted only with Bidders who have submitted a Bid which obviously conforms in all material aspects to the Invitation for Bids. Clarification of a Bid must be documented in writing and included with the Bid. Clarifications may not be used to revise a Bid or the Invitation for Bids."

2.30. Delete Section 7.1.2 and substitute the following:

"7.1.2 The performance and payment bonds shall conform to the requirements of the General Conditions of the Contract. If the furnishing of such bonds is stipulated in the Bidding Documents, the cost shall be included in the Bid."

2.31. Delete the language of Section 7.1.3 and insert the word "Reserved."

2.32. Delete Section 7.2.1 and substitute the following:

"7.2.1 The Owner will tender a signed Contract for Construction to the Bidder and the Bidder shall return the fully executed Contract for Construction to the Owner within seven days thereafter. The Bidder shall deliver the required bonds and certificate of insurance to the Owner not later than three days following the date of execution of the Contract."

2.33. Delete the language of Section 7.2.2 and insert the word "Reserved."

2.34. Delete the language of Article 8 and insert the following:

"Unless otherwise required in the Bidding Documents, the Agreement for the Work will be written on AIA Document A105-2017, Standard Short Form of Agreement Between Owner and Contractor."

2.35. Insert the following Article 9:

**"ARTICLE 9 MISCELLANEOUS**

**9.1 CONTRACTOR LICENSING**

Contractors and Subcontractors listed in Section 7 of the Bid Form who are required by the South Carolina Code of Laws to be licensed, must be licensed at the time of bidding.

**9.2 SUBMITTING CONFIDENTIAL INFORMATION**

For every document Bidder submits in response to or with regard to this solicitation or request, Bidder must separately mark with the word "CONFIDENTIAL" on every page, or portion thereof, that Bidder contends contains information that is exempt from public disclosure because it is either (a) a trade secret as defined in Section 30-4-40(a) (1), or (b) privileged & confidential, as that phrase is used in Section 11-35-410. For every document Bidder submits in response to or with regard to this solicitation or request, Bidder must separately mark with the words "TRADE SECRET" every page, or portion thereof, that Bidder contends contains a trade secret as that term is defined by Section 39-8-20 of the Trade Secrets Act. For every document Bidder submits in response to or with regard to this solicitation or request, Bidder must separately mark with the word "PROTECTED" every page, or



portion thereof, that Bidder contends is protected by Section 11-35-1810. All markings must be conspicuous; use color, bold, underlining, or some other method in order to conspicuously distinguish the mark from the other text. Do not mark your entire bid as confidential, trade secret, or protected! If your bid or any part thereof, is improperly marked as confidential or trade secret or protected, the State may, in its sole discretion, determine it nonresponsive. If only portions of a page are subject to some protection, do not mark the entire page. By submitting a response to this solicitation, Bidder (1) agrees to the public disclosure of every page of every document regarding this solicitation or request that was submitted at any time prior to entering into a contract (including, but not limited to, documents contained in a response, documents submitted to clarify a response, & documents submitted during negotiations), unless the page is conspicuously marked "TRADE SECRET" or "CONFIDENTIAL" or "PROTECTED", (2) agrees that any information not marked, as required by these bidding instructions, as a "Trade Secret" is not a trade secret as defined by the Trade Secrets Act, & (3) agrees that, notwithstanding any claims or markings otherwise, any prices, commissions, discounts, or other financial figures used to determine the award, as well as the final contract amount, are subject to public disclosure. In determining whether to release documents, the State will detrimentally rely on Bidder's marking of documents, as required by these bidding instructions, as being either "Confidential" or "Trade Secret" or "PROTECTED". By submitting a response, Bidder agrees to defend, indemnify & hold harmless the State of South Carolina, its officers & employees, from every claim, demand, loss, expense, cost, damage or injury, including attorney's fees, arising out of or resulting from the State withholding information that Bidder marked as "confidential" or "trade secret" or "PROTECTED".

### 9.3 BUILDER'S RISK INSURANCE

Successful contractor is required to provide builder's risk insurance on the project."

END OF DOCUMENT

**SECTION 01 1000**  
**SUMMARY**

**PART 1 GENERAL**

**1.01 PROJECT**

- A. Project Name: Repaving and Parking Lot Repairs for Thunderbolt Career & Technology Center and Colleton County Middle School.
- B. Owner's Name: Colleton County School District.
- C. Architect's Name: The FWA Group, PA - Architects.
- D. Civil Engineer's Name: Cranston Engineering Group, Inc.
- E. Architect's Project Number: #2626.01.
- F. The Project consists of the removal of existing paving materials and repaving the same areas for the existing parking and drive aisles of Thunderbolt Career & Technology Center and Colleton County Middle School. The work will include the demolition of existing paving materials, preparation of the existing base, and repaving to match the existing limits of the current areas as described by the construction documents.

**1.02 CONTRACT DESCRIPTION**

- A. Contract Type: A single prime contract based on a Stipulated Price as described by the AIA documents as provided in Section 00 of these specifications to include sample agreements and supplemental instructions.

**1.03 WORK BY OWNER**

**1.04 OWNER OCCUPANCY**

- A. Owner intends to occupy the site during all times as the work progresses. The Owner will occupy this Project upon Substantial Completion.
- B. Cooperate with Owner to minimize conflict and to facilitate Owner's current site use operations.
- C. Schedule and coordinate the Work to accommodate Owner occupancy.

**1.05 CONTRACTOR USE OF SITE AND PREMISES**

- A. Construction Operations: Limited to areas noted on Drawings and coordinated with the Owner.
  - 1. Locate and conduct construction activities in ways that will limit disturbance to site.
- B. Arrange use of site and premises to allow:
  - 1. Owner occupancy.
  - 2. Work by Others.
  - 3. Work by Owner.
- C. Provide access to and from site as required by law and by Owner:
  - 1. Emergency Building Exits During Construction: Keep all exits required by code open during construction period; provide temporary exit signs if exit routes are temporarily altered.
  - 2. Do not obstruct roadways, sidewalks, or other public ways without permit.
- D. Existing building spaces may be used for storage of materials and equipment as reviewed and approved by the Owner prior to the beginning of the Work.
- E. Time Restrictions:
  - 1. Limit conduct of especially noisy, malodorous, and dusty work to the hours of outside of normal school hours. Contractor is to coordinate the need to perform noisy work with the Owner.

**1.06 WORK SEQUENCE**

- A. Coordinate construction schedule and operations with Owner.

Repaving and Parking Lot Repairs for Thunderbolt Career & Technology Center and  
Colleton County Middle School

2626.01

**PART 2 PRODUCTS - NOT USED**

**PART 3 EXECUTION - NOT USED**

**END OF SECTION**

**SECTION 01 2000**  
**PRICE AND PAYMENT PROCEDURES**

**PART 1 GENERAL**

**1.01 SECTION INCLUDES**

- A. Procedures for preparation and submittal of applications for progress payments.
- B. Documentation of changes in Contract Sum and Contract Time.
- C. Change procedures.
- D. Correlation of Contractor submittals based on changes.
- E. Procedures for preparation and submittal of application for final payment.

**1.02 SCHEDULE OF VALUES**

- A. Electronic media printout including equivalent information will be considered in lieu of standard form specified; submit draft to Architect for approval.
- B. Forms filled out by hand will not be accepted.

**1.03 APPLICATIONS FOR PROGRESS PAYMENTS**

- A. Payment Period: Submit at intervals stipulated in the Agreement.
- B. Electronic media printout including equivalent information will be considered in lieu of standard form specified; submit sample to Architect for approval.
- C. Forms filled out by hand will not be accepted.
- D. Execute certification by signature of authorized officer.
- E. Use data from approved Schedule of Values. Provide dollar value in each column for each line item for portion of work performed and for stored products.
- F. List each authorized Change Order as a separate line item, listing Change Order number and dollar amount as for an original item of work.
- G. Submit three hard-copies of each Application for Payment.
- H. Include the following with the application:
  - 1. Transmittal letter as specified for submittals in Section 01 3000.
  - 2. Construction progress schedule, revised and current as specified in Section 01 3000.
  - 3. Partial release of liens from major subcontractors and vendors.

**1.04 MODIFICATION PROCEDURES**

- A. For minor changes not involving an adjustment to the Contract Sum or Contract Time, Architect will issue instructions directly to Contractor.
- B. For other required changes, Architect will issue a document signed by Owner instructing Contractor to proceed with the change, for subsequent inclusion in a Change Order.
  - 1. The document will describe the required changes and will designate method of determining any change in Contract Sum or Contract Time.
  - 2. Promptly execute the change.
- C. For changes for which advance pricing is desired, Architect will issue a document that includes a detailed description of a proposed change with supplementary or revised drawings and specifications, a change in Contract Time for executing the change with a stipulation of any overtime work required and the period of time during which the requested price will be considered valid. Contractor shall prepare and submit a fixed price quotation within the time period noted.
- D. Computation of Change in Contract Amount: As specified in the Agreement and Conditions of the Contract.
- E. Substantiation of Costs: Provide full information required for evaluation.
  - 1. On request, provide the following data:
    - a. Quantities of products, labor, and equipment.

- b. Taxes, insurance, and bonds.
  - c. Overhead and profit.
  - d. Justification for any change in Contract Time.
  - e. Credit for deletions from Contract, similarly documented.
- F. Execution of Change Orders: Architect will issue Change Orders for signatures of parties as provided in the Conditions of the Contract.
- G. After execution of Change Order, promptly revise Schedule of Values and Application for Payment forms to record each authorized Change Order as a separate line item and adjust the Contract Sum.
- H. Promptly revise progress schedules to reflect any change in Contract Time, revise sub-schedules to adjust times for other items of work affected by the change, and resubmit.
- I. Promptly enter changes in Project Record Documents.

**1.05 APPLICATION FOR FINAL PAYMENT**

- A. Prepare Application for Final Payment as specified for progress payments, identifying total adjusted Contract Sum, previous payments, and sum remaining due.

**PART 2 PRODUCTS - NOT USED**

**PART 3 EXECUTION - NOT USED**

**END OF SECTION**

**SECTION 01 3000**  
**ADMINISTRATIVE REQUIREMENTS**

**PART 1 GENERAL**

**1.01 SECTION INCLUDES**

- A. General administrative requirements.
- B. Preconstruction meeting.
- C. Site mobilization meeting.
- D. Progress meetings.
- E. Construction progress schedule.
- F. Contractor's daily reports.
- G. Submittals for review, information, and project closeout.
- H. Requests for Interpretation (RFI) procedures.
- I. Submittal procedures.

**1.02 RELATED REQUIREMENTS**

- A. Section 01 6000 - Product Requirements: General product requirements.
- B. Section 01 7000 - Execution and Closeout Requirements: Additional coordination requirements.
- C. Section 01 7800 - Closeout Submittals: Project record documents; operation and maintenance data; warranties and bonds.

**1.03 GENERAL ADMINISTRATIVE REQUIREMENTS**

- A. Comply with requirements of Section 01 7000 - Execution and Closeout Requirements for coordination of execution of administrative tasks with timing of construction activities.
- B. Make the following types of submittals to Architect:
  - 1. Requests for Interpretation (RFI).
  - 2. Requests for substitution.
  - 3. Shop drawings, product data, and samples.
  - 4. Test and inspection reports.
  - 5. Design data.
  - 6. Manufacturer's instructions and field reports.
  - 7. Applications for payment and change order requests.
  - 8. Progress schedules.
  - 9. Coordination drawings.
  - 10. Correction Punch List and Final Correction Punch List for Substantial Completion.
  - 11. Closeout submittals.

**PART 2 PRODUCTS - NOT USED**

**PART 3 EXECUTION**

**3.01 PRECONSTRUCTION MEETING**

- A. Architect will schedule a meeting after Notice to Proceed.
- B. Attendance Required:
  - 1. Owner.
  - 2. Architect.
  - 3. Contractor.
- C. Agenda:
  - 1. Execution of Owner-Contractor Agreement.
  - 2. Submission of executed bonds and insurance certificates.
  - 3. Distribution of Contract Documents.
  - 4. Submission of list of subcontractors, schedule of values, and progress schedule.

5. Submission of initial Submittal schedule.
  6. Designation of personnel representing the parties to Contract, Owner, Architect and Engineer.
  7. Procedures and processing of field decisions, submittals, substitutions, applications for payments, proposal request, Change Orders, and Contract closeout procedures.
  8. Scheduling.
- D. Record minutes and distribute copies within two days after meeting to participants, with copies to Architect, Engineer, Owner, participants, and those affected by decisions made.

### **3.02 SITE MOBILIZATION MEETING**

- A. Schedule meeting at the Project site prior to Contractor occupancy.
- B. Attendance Required:
1. Contractor.
  2. Owner.
  3. Architect.
  4. Engineering consultants.
  5. Contractor's superintendent.
  6. Major subcontractors.
- C. Agenda:
1. Use of premises by Owner and Contractor.
  2. Owner's requirements.
  3. Construction facilities and controls provided by Owner.
  4. Temporary utilities provided by Owner.
  5. Security and housekeeping procedures.
  6. Schedules.
  7. Application for payment procedures.
  8. Procedures for maintaining record documents.
- D. Record minutes and distribute copies within two days after meeting to participants, with two copies to Architect, Engineer, Owner, participants, and those affected by decisions made.

### **3.03 PROGRESS MEETINGS**

- A. Schedule and administer meetings throughout progress of the work at maximum bi-monthly intervals.
- B. Make arrangements for meetings, prepare agenda with copies for participants, preside at meetings.
- C. Attendance Required:
1. Contractor.
  2. Owner.
  3. Architect.
  4. Engineering consultants.
  5. Contractor's superintendent.
- D. Agenda:
1. Review minutes of previous meetings.
  2. Review of work progress.
  3. Field observations, problems, and decisions.
  4. Identification of problems that impede, or will impede, planned progress.
  5. Review of submittals schedule and status of submittals.
  6. Review of RFIs log and status of responses.
  7. Maintenance of progress schedule.
  8. Maintenance of quality and work standards.
  9. Effect of proposed changes on progress schedule and coordination.
  10. Other business relating to work.

- E. Record minutes and distribute copies within two days after meeting to participants, with copies to Architect, Owner, participants, and those affected by decisions made.

#### **3.04 CONSTRUCTION PROGRESS SCHEDULE**

- A. Within 10 days after date of the Agreement, submit preliminary schedule defining planned operations for the first 15 days of work, with a general outline for remainder of work.
- B. Within 5 days after review of preliminary schedule, submit draft of proposed complete schedule for review.
  - 1. Include written certification that major Subcontractors have reviewed and accepted proposed schedule.
- C. Within 5 days after joint review, submit complete schedule.
- D. Submit updated schedule with each Application for Payment.

#### **3.05 DAILY CONSTRUCTION REPORTS**

- A. Include only factual information. Do not include personal remarks or opinions regarding operations and/or personnel.
- B. Prepare a daily construction report recording the following information concerning events at Project site and project progress:
  - 1. Date.
  - 2. High and low temperatures, and general weather conditions.
  - 3. List of subcontractors at Project site.
  - 4. Material deliveries.
  - 5. Safety, environmental, or industrial relations incidents.
  - 6. Meetings and significant decisions.
  - 7. Stoppages, delays, shortages, and losses. Include comparison between scheduled work activities (in Contractor's most recently updated and published schedule) and actual activities. Explain differences, if any. Note days or periods when no work was in progress and explain the reasons why.
  - 8. Testing and/or inspections performed.
  - 9. Signature of Contractor's authorized representative.

#### **3.06 REQUESTS FOR INTERPRETATION (RFI)**

- A. Definition: A request seeking one of the following:
  - 1. An interpretation, amplification, or clarification of some requirement of Contract Documents arising from inability to determine from them the exact material, process, or system to be installed; or when the elements of construction are required to occupy the same space (interference); or when an item of work is described differently at more than one place in Contract Documents.
  - 2. A resolution to an issue which has arisen due to field conditions and affects design intent.
- B. Preparation: Prepare an RFI immediately upon discovery of a need for interpretation of Contract Documents. Failure to submit a RFI in a timely manner is not a legitimate cause for claiming additional costs or delays in execution of the work.
  - 1. Prepare a separate RFI for each specific item.
    - a. Review, coordinate, and comment on requests originating with subcontractors and/or materials suppliers.
    - b. Do not forward requests which solely require internal coordination between subcontractors.
  - 2. Combine RFI and its attachments into a single electronic file. PDF format is preferred.
- C. Reason for the RFI: Prior to initiation of an RFI, carefully study all Contract Documents to confirm that information sufficient for their interpretation is definitely not included.
  - 1. Include in each request Contractor's signature attesting to good faith effort to determine from Contract Documents information requiring interpretation.
  - 2. Unacceptable Uses for RFIs: Do not use RFIs to request the following:
    - a. Approval of submittals (use procedures specified elsewhere in this section).



- b. Approval of substitutions (see Section - 01 6000 - Product Requirements)
- c. Changes that entail change in Contract Time and Contract Sum (comply with provisions of the Conditions of the Contract).
- d. Different methods of performing work than those indicated in the Contract Drawings and Specifications (comply with provisions of the Conditions of the Contract).
- 3. Improper RFIs: Requests not prepared in compliance with requirements of this section, and/or missing key information required to render an actionable response. They will be returned without a response, with an explanatory notation.
- 4. Frivolous RFIs: Requests regarding information that is clearly indicated on, or reasonably inferable from, Contract Documents, with no additional input required to clarify the question. They will be returned without a response, with an explanatory notation.
  - a. The Owner reserves the right to assess the Contractor for the costs (on time-and-materials basis) incurred by the Architect, and any of its consultants, due to processing of such RFIs.
- D. Content: Include identifiers necessary for tracking the status of each RFI, and information necessary to provide an actionable response.
  - 1. Official Project name and number, and any additional required identifiers established in Contract Documents.
  - 2. Issue date, and requested reply date.
  - 3. Reference to particular Contract Document(s) requiring additional information/interpretation. Identify pertinent drawing and detail number and/or specification section number, title, and paragraph(s).
  - 4. Contractor's suggested resolution: A written and/or a graphic solution, to scale, is required in cases where clarification of coordination issues is involved, for example; routing, clearances, and/or specific locations of work shown diagrammatically in Contract Documents. If applicable, state the likely impact of the suggested resolution on Contract Time or the Contract Sum.
- E. Attachments: Include sketches, coordination drawings, descriptions, photos, submittals, and other information necessary to substantiate the reason for the request.
- F. RFI Log: Prepare and maintain a tabular log of RFIs for the duration of the project.
  - 1. Indicate current status of every RFI. Update log promptly and on a regular basis.
  - 2. Note dates of when each request is made, and when a response is received.
  - 3. Highlight items requiring priority or expedited response.
  - 4. Highlight items for which a timely response has not been received to date.
- G. Review Time: Architect will respond and return RFIs to Contractor within five calendar days of receipt. For the purpose of establishing the start of the mandated response period, RFIs received after 12:00 noon will be considered as having been received on the following regular working day.
- H. Responses: Content of answered RFIs will not constitute in any manner a directive or authorization to perform extra work or delay the project. If in Contractor's belief it is likely to lead to a change to Contract Sum or Contract Time, promptly issue a notice to this effect, and follow up with an appropriate Change Order request to Owner.
  - 1. Response may include a request for additional information, in which case the original RFI will be deemed as having been answered, and an amended one is to be issued forthwith. Identify the amended RFI with an R suffix to the original number.
  - 2. Do not extend applicability of a response to specific item to encompass other similar conditions, unless specifically so noted in the response.
  - 3. Upon receipt of a response, promptly review and distribute it to all affected parties, and update the RFI Log.
  - 4. Notify Architect within five calendar days if an additional or corrected response is required by submitting an amended version of the original RFI, identified as specified above.

### 3.07 SUBMITTALS FOR REVIEW

- A. When the following are specified in individual sections, submit them for review:

1. Product data.
  2. Shop drawings.
  3. Samples for selection.
- B. Submit to Architect for review for the limited purpose of checking for compliance with information given and the design concept expressed in Contract Documents.
- C. Samples will be reviewed for aesthetic, color, or finish selection.
- D. After review, provide copies and distribute in accordance with SUBMITTAL PROCEDURES article below and for record documents purposes described in Section 01 7800 - Closeout Submittals.

### **3.08 SUBMITTALS FOR INFORMATION**

- A. When the following are specified in individual sections, submit them for information:
1. Design data.
  2. Certificates.
  3. Test reports.
  4. Inspection reports.
  5. Manufacturer's instructions.
  6. Manufacturer's field reports.
  7. Other types indicated.
- B. Submit for Architect's knowledge as contract administrator or for Owner.

### **3.09 SUBMITTALS FOR PROJECT CLOSEOUT**

- A. Submit Correction Punch List for Substantial Completion.
- B. Submit Final Correction Punch List for Substantial Completion.
- C. When the following are specified in individual sections, submit them at project closeout in compliance with requirements of Section 01 7800 - Closeout Submittals:
1. Project record documents.
  2. Operation and maintenance data.
  3. Warranties.
  4. Bonds.
  5. Other types as indicated.
- D. Submit for Owner's benefit during and after project completion.

### **3.10 SUBMITTAL PROCEDURES**

- A. General Requirements:
1. Use a separate transmittal for each item.
  2. Submit separate packages of submittals for review and submittals for information, when included in the same specification section.
  3. Identify: Project; Contractor; subcontractor or supplier; pertinent drawing and detail number; and specification section number and article/paragraph, as appropriate on each copy.
  4. Apply Contractor's stamp, signed or initialed certifying that review, approval, verification of products required, field dimensions, adjacent construction work, and coordination of information is in accordance with the requirements of the work and Contract Documents.
    - a. Submittals from sources other than the Contractor, or without Contractor's stamp will not be acknowledged, reviewed, or returned.
  5. Deliver each submittal on date noted in submittal schedule, unless an earlier date has been agreed to by all affected parties, and is of the benefit to the project.
    - a. Deliver submittals to Architect at business address.
  6. Schedule submittals to expedite the Project, and coordinate submission of related items.
    - a. For sequential reviews involving Architect's consultants, Owner, or another affected party, allow an additional 7 days.
  7. Identify variations from Contract Documents and product or system limitations that may be detrimental to successful performance of the completed work.

8. Provide space for Contractor and Architect review stamps.
  9. Distribute reviewed submittals. Instruct parties to promptly report inability to comply with requirements.
  10. Incomplete submittals will not be reviewed, unless they are partial submittals for distinct portion(s) of the work, and have received prior approval for their use.
  11. Submittals not requested will not be recognized or processed.
- B. Product Data Procedures:
1. Submit only information required by individual specification sections.
  2. Collect required information into a single submittal.
  3. Submit concurrently with related shop drawing submittal.
  4. Do not submit (Material) Safety Data Sheets for materials or products.
- C. Shop Drawing Procedures:
1. Prepare accurate, drawn-to-scale, original shop drawing documentation by interpreting Contract Documents and coordinating related work.
  2. Do not reproduce Contract Documents to create shop drawings.
  3. Generic, non-project-specific information submitted as shop drawings do not meet the requirements for shop drawings.
- D. Samples Procedures:
1. Transmit related items together as single package.
  2. Identify each item to allow review for applicability in relation to shop drawings showing installation locations.

### 3.11 SUBMITTAL REVIEW

- A. Submittals for Review: Architect or Engineer will review each submittal, and approve, or take other appropriate action.
- B. Submittals for Information: Architect will acknowledge receipt and review. See below for actions to be taken.
- C. Architect's or Engineer's actions will be reflected by marking each returned submittal using virtual stamp on electronic submittals.
1. Notations may be made directly on submitted items and/or listed on appended Submittal Review cover sheet.
- D. Architect's and/or Engineer's actions on items submitted for review:
1. Authorizing purchasing, fabrication, delivery, and installation:
    - a. "Approved", or language with same legal meaning.
    - b. "Approved as Noted, Resubmission not required", or language with same legal meaning.
      - 1) At Contractor's option, submit corrected item, with review notations acknowledged and incorporated.
    - c. "Approved as Noted, Resubmit for Record", or language with same legal meaning.
      - 1) Resubmit corrected item, with review notations acknowledged and incorporated. Resubmit separately, or as part of project record documents.
      - 2) Non-responsive resubmittals may be rejected.
  2. Not Authorizing fabrication, delivery, and installation:
    - a. "Revise and Resubmit".
      - 1) Resubmit revised item, with review notations acknowledged and incorporated.
      - 2) Non-responsive resubmittals may be rejected.
    - b. "Rejected".
      - 1) Submit item complying with requirements of Contract Documents.
- E. Architect's or Engineer's actions on items submitted for information:
1. Items for which no action was taken:
    - a. "Received" - to notify the Contractor that the submittal has been received for record only.
  2. Items for which action was taken:

- a. "Reviewed" - no further action is required from Contractor.

**END OF SECTION**

**SECTION 01 3553  
SECURITY PROCEDURES**

**PART 1 GENERAL**

**1.01 SECTION INCLUDES**

- A. Security measures including entry control, personnel identification, and miscellaneous restrictions.

**1.02 RELATED REQUIREMENTS**

- A. Section 01 1000 - Summary: use of premises and occupancy.

**1.03 ENTRY CONTROL**

- A. Restrict entrance of persons and vehicles into Project site and existing facilities.
- B. Allow entrance only to authorized persons with proper identification.
- C. Maintain log of workers and visitors, make available to Owner on request.
- D. Owner will control entrance of persons and vehicles related to Owner's operations.

**1.04 PERSONNEL IDENTIFICATION**

- A. Provide identification badge or other form of identification to each person authorized to enter premises and work at the site.
- B. Maintain a list of accredited persons, submit copy to Owner on request.
- C. Require return of badges at expiration of their employment on the Work.

**1.05 RESTRICTIONS**

- A. Do not allow cameras on site or photographs taken except by written approval of Owner.

**PART 2 PRODUCTS - NOT USED**

**PART 3 EXECUTION - NOT USED**

**END OF SECTION**

**SECTION 01 4000**  
**QUALITY REQUIREMENTS**

**PART 1 GENERAL**

**1.01 SECTION INCLUDES**

- A. Submittals.
- B. Quality assurance.
- C. References and standards.
- D. Control of installation.
- E. Tolerances.
- F. Manufacturers' field services.
- G. Defect Assessment.

**1.02 RELATED REQUIREMENTS**

- A. Section 01 3000 - Administrative Requirements: Submittal procedures.
- B. Section 01 4216 - Definitions.
- C. Section 01 6000 - Product Requirements: Requirements for material and product quality.

**1.03 DEFINITIONS**

- A. Design Data: Design-related, signed and sealed drawings, calculations, specifications, certifications, shop drawings and other submittals provided by Contractor, and prepared directly by, or under direct supervision of, appropriately licensed design professional.

**1.04 SUBMITTALS**

- A. See Section 01 3000 - Administrative Requirements, for submittal procedures.
- B. Design Data: Submit for Architect's or Engineer's knowledge as contract administrator for the limited purpose of assessing compliance with information given and the design concept expressed in the Contract Documents, or for Owner's information.
  - 1. Include a statement or certification attesting that design data complies with criteria indicated, such as applicable codes, loads, functional, and similar engineering requirements.
  - 2. Include signature and seal of design professional responsible for allocated design services on calculations and drawings.
- C. Test Reports: After each test/inspection, promptly submit two copies of report to Architect, Engineer and to Contractor.
  - 1. Include:
    - a. Date issued.
    - b. Project title and number.
    - c. Name of inspector.
    - d. Date and time of sampling or inspection.
    - e. Identification of product and specifications section.
    - f. Type of test/inspection.
    - g. Date of test/inspection.
    - h. Results of test/inspection.
    - i. Compliance with Contract Documents.
    - j. When requested by Architect or Engineer, provide interpretation of results.
  - 2. Test report submittals are for Architect's or Engineer's knowledge as contract administrator for the limited purpose of assessing compliance with information given and the design concept expressed in the Contract Documents, or for Owner's information.
- D. Certificates: When specified in individual specification sections, submit certification by the manufacturer and Contractor or installation/application subcontractor to Architect and Engineer, in quantities specified for Product Data.

1. Indicate material or product complies with or exceeds specified requirements. Submit supporting reference data, affidavits, and certifications as appropriate.
2. Certificates may be recent or previous test results on material or product, but must be acceptable to Architect and Engineer.

#### **1.05 REFERENCES AND STANDARDS**

- A. For products and workmanship specified by reference to a document or documents not included in the Project Manual, also referred to as reference standards, comply with requirements of the standard, except when more rigid requirements are specified or are required by applicable codes.
- B. Comply with reference standard of date of issue current on date of Contract Documents, except where a specific date is established by applicable code.
- C. Obtain copies of standards where required by product specification sections.
- D. Maintain copy at project site during submittals, planning, and progress of the specific work, until Substantial Completion.
- E. Should specified reference standards conflict with Contract Documents, request clarification from Architect and Engineer before proceeding.
- F. Neither the contractual relationships, duties, or responsibilities of the parties in Contract nor those of Architect and Engineer shall be altered from Contract Documents by mention or inference otherwise in any reference document.

#### **PART 2 PRODUCTS - NOT USED**

#### **PART 3 EXECUTION**

##### **3.01 CONTROL OF INSTALLATION**

- A. Monitor quality control over suppliers, manufacturers, products, services, site conditions, and workmanship, to produce work of specified quality.
- B. Comply with specified standards as minimum quality for the work except where more stringent tolerances, codes, or specified requirements indicate higher standards or more precise workmanship.
- C. Have work performed by persons qualified to produce required and specified quality.
- D. Verify that field measurements are as indicated on shop drawings or as instructed by the manufacturer.

##### **3.02 DEFECT ASSESSMENT**

- A. Replace Work or portions of the Work not complying with specified requirements.
- B. If, in the opinion of Architect/Engineer, it is not practical to remove and replace the work, Architect/Engineer will direct an appropriate remedy or adjust payment.

**END OF SECTION**

**SECTION 01 4100  
REGULATORY REQUIREMENTS**

**PART 1 GENERAL**

**1.01 SUMMARY OF REFERENCE STANDARDS**

- A. Regulatory requirements applicable to this project are the following:
- B. 36 CFR 1191 - Americans with Disabilities Act (ADA) Accessibility Guidelines for Buildings and Facilities; Architectural Barriers Act (ABA) Accessibility Guidelines; current edition.
- C. ADA Standards - Americans with Disabilities Act (ADA) Standards for Accessible Design; 2010.
- D. 29 CFR 1910 - Occupational Safety and Health Standards; current edition.
- E. State of South Carolina amendments to some or all of the following.
- F. City of Walterboro amendments to some or all of the following.
- G. Current requirements of the South Carolina Department of Transportation.
- H. ICC A117.1 - Accessible and Usable Buildings and Facilities; 2017.

**1.02 RELATED REQUIREMENTS**

- A. Section 01 4000 - Quality Requirements.

**1.03 QUALITY ASSURANCE**

- A. Contractor's Designer Qualifications: Refer to Section - 01 4000 - Quality Requirements.

**PART 2 PRODUCTS - NOT USED**

**PART 3 EXECUTION - NOT USED**

**END OF SECTION**



**SECTION 01 4216**  
**DEFINITIONS**

**PART 1 GENERAL**

**1.01 SUMMARY**

- A. This section supplements the definitions contained in the General Conditions.
- B. Other definitions are included in individual specification sections.

**1.02 DEFINITIONS**

- A. Furnish: To supply, deliver, unload, and inspect for damage.
- B. Install: To unpack, assemble, erect, apply, place, finish, cure, protect, clean, start up, and make ready for use.
- C. Product: Material, machinery, components, equipment, fixtures, and systems forming the work result. Not materials or equipment used for preparation, fabrication, conveying, or erection and not incorporated into the work result. Products may be new, never before used, or re-used materials or equipment.
- D. Provide: To furnish and install.
- E. Supply: Same as Furnish.

**PART 2 PRODUCTS - NOT USED**

**PART 3 EXECUTION - NOT USED**

**END OF SECTION**

**SECTION 01 5000**  
**TEMPORARY FACILITIES AND CONTROLS**

**PART 1 GENERAL**

**1.01 SECTION INCLUDES**

- A. Temporary telecommunications services.
- B. Temporary sanitary facilities.
- C. Temporary Controls: Barriers, enclosures, and fencing.
- D. Security requirements.
- E. Vehicular access and parking.
- F. Waste removal facilities and services.
- G. Project identification sign.

**1.02 RELATED REQUIREMENTS**

- A. Section 01 3553 - Security Procedures
- B. Section 01 5100 - Temporary Utilities.

**1.03 TELECOMMUNICATIONS SERVICES**

- A. Provide, maintain, and pay for telecommunications services to field office/operations at time of project mobilization.

**1.04 TEMPORARY SANITARY FACILITIES**

- A. Provide and maintain required facilities and enclosures. Provide at time of project mobilization.
- B. Use of existing facilities is not permitted.
- C. Maintain daily in clean and sanitary condition.

**1.05 BARRIERS**

- A. Provide barriers to prevent unauthorized entry to construction areas, to prevent access to areas that could be hazardous to workers or the public, to allow for owner's use of site and to protect existing facilities and adjacent properties from damage from construction operations and demolition.
- B. Provide barricades and walkways required by governing authorities for public rights-of-way and for public access to existing building.
- C. Provide protection for plants designated to remain. Replace damaged plants.
- D. Protect non-owned vehicular traffic, stored materials, site, and structures from damage.
- E. Traffic Controls: Refer to civil document for traffic control requirements.

**1.06 FENCING**

- A. Construction: Contractor's option.

**1.07 SECURITY - SEE SECTION 01 3553**

- A. Provide security and facilities to protect Work, existing facilities, and Owner's operations from unauthorized entry, vandalism, or theft.

**1.08 VEHICULAR ACCESS AND PARKING**

- A. Comply with regulations relating to use of streets and sidewalks, access to emergency facilities, and access for emergency vehicles.
- B. Coordinate access and haul routes with governing authorities and Owner.
- C. Provide and maintain access to fire hydrants, free of obstructions.
- D. Provide means of removing mud/debris from vehicle wheels before entering streets.
- E. Designated existing on-site roads may be used for construction traffic. Coordinate road use with Owner.

- F. Provide temporary parking areas to accommodate construction personnel. When site space is not adequate, provide additional off-site parking.

**1.09 WASTE REMOVAL**

- A. Provide waste removal facilities and services as required to maintain the site in clean and orderly condition.
- B. Provide containers with lids. Remove trash from site periodically.

**1.10 PROJECT IDENTIFICATION**

- A. No other signs are allowed without Owner permission except those required by law.

**1.11 REMOVAL OF UTILITIES, FACILITIES, AND CONTROLS**

- A. Remove temporary utilities, equipment, facilities, materials, prior to Date of Substantial Completion inspection.
- B. Clean and repair damage caused by installation or use of temporary work.
- C. Restore existing facilities used during construction to original condition.
- D. Restore new permanent facilities used during construction to specified condition.

**PART 2 PRODUCTS - NOT USED**

**PART 3 EXECUTION - NOT USED**

**END OF SECTION**

**SECTION 01 5100**  
**TEMPORARY UTILITIES**

**PART 1 GENERAL**

**1.01 SECTION INCLUDES**

- A. Temporary Utilities: Provision of electricity, lighting, and water.

**1.02 RELATED REQUIREMENTS**

- A. Section 01 5000 - Temporary Facilities and Controls:
  - 1. Temporary telecommunications services for administrative purposes.
  - 2. Temporary sanitary facilities required by law.

**1.03 REFERENCE STANDARDS**

- A. 29 CFR 1926 - U.S. Occupational Safety and Health Standards; current edition.

**1.04 TEMPORARY ELECTRICITY**

- A. Cost: By Contractor.
- B. Connect to Owner's existing power service.
  - 1. Do not disrupt Owner's need for continuous service.
  - 2. Exercise measures to conserve energy.
- C. Provide adequate distribution equipment, wiring, and outlets to provide single phase branch circuits for power and lighting.

**1.05 TEMPORARY LIGHTING FOR CONSTRUCTION PURPOSES**

- A. Provide and maintain LED or high-intensity discharge lighting as suitable for the application for construction operations in accordance with requirements of 29 CFR 1926 and authorities having jurisdiction.
- B. Maintain lighting and provide routine repairs.

**1.06 TEMPORARY WATER SERVICE**

- A. Cost of Water Used: By Contractor.
- B. Connect to existing water source.
  - 1. Exercise measures to conserve water.
  - 2. Provide separate metering and reimburse Owner for cost of water used.
- C. Extend branch piping with outlets located so water is available by hoses with threaded connections. Provide temporary pipe insulation to prevent freezing.

**PART 2 PRODUCTS - NOT USED**

**PART 3 EXECUTION - NOT USED**

**END OF SECTION**

**SECTION 01 6000  
PRODUCT REQUIREMENTS**

**PART 1 GENERAL**

**1.01 SECTION INCLUDES**

- A. General product requirements.
- B. Transportation, handling, storage and protection.
- C. Maintenance materials, including extra materials, spare parts, tools, and software.

**1.02 RELATED REQUIREMENTS**

- A. Section 01 4000 - Quality Requirements: Product quality monitoring.

**1.03 SUBMITTALS**

- A. Product Data Submittals: Submit manufacturer's standard published data. Mark each copy to identify applicable products, models, options, and other data. Supplement manufacturers' standard data to provide information specific to this Project.

**PART 2 PRODUCTS**

**2.01 NEW PRODUCTS**

- A. Provide new products unless specifically required or permitted by Contract Documents.

**2.02 MAINTENANCE MATERIALS**

- A. Furnish extra materials, spare parts, tools, and software of types and in quantities specified in individual specification sections.
- B. Deliver to Project site; obtain receipt prior to final payment.

**PART 3 EXECUTION**

**3.01 TRANSPORTATION AND HANDLING**

- A. Coordinate schedule of product delivery to designated prepared areas in order to minimize site storage time and potential damage to stored materials.
- B. Transport and handle products in accordance with manufacturer's instructions.
- C. Transport materials in covered trucks to prevent contamination of product and littering of surrounding areas.
- D. Promptly inspect shipments to ensure that products comply with requirements, quantities are correct, and products are undamaged.

**3.02 STORAGE AND PROTECTION**

- A. Provide protection of stored materials and products against theft, casualty, or deterioration.
- B. Designate receiving/storage areas for incoming products so that they are delivered according to installation schedule and placed convenient to work area in order to minimize waste due to excessive materials handling and misapplication. See Section 01 7419.
- C. Store and protect products in accordance with manufacturers' instructions.
- D. Comply with manufacturer's warranty conditions, if any.
- E. Store loose granular materials on solid flat surfaces in a well-drained area. Prevent mixing with foreign matter.
- F. Prevent contact with material that may cause corrosion, discoloration, or staining.
- G. Provide equipment and personnel to store products by methods to prevent soiling, disfigurement, or damage.
- H. Arrange storage of products to permit access for inspection. Periodically inspect to verify products are undamaged and are maintained in acceptable condition.

**END OF SECTION**

**SECTION 01 7000**  
**EXECUTION AND CLOSEOUT REQUIREMENTS**

**PART 1 GENERAL**

**1.01 SECTION INCLUDES**

- A. Pre-installation meetings.
- B. Cutting and patching.
- C. Cleaning and protection.
- D. Closeout procedures, including Contractor's Correction Punch List, except payment procedures.

**1.02 RELATED REQUIREMENTS**

- A. Section 01 3000 - Administrative Requirements: Submittals procedures, Electronic document submittal service.
- B. Section 01 4000 - Quality Requirements: Testing and inspection procedures.
- C. Section 01 5100 - Temporary Utilities: Temporary heating, cooling, and ventilating facilities.
- D. Section 01 7800 - Closeout Submittals: Project record documents, operation and maintenance data, warranties, and bonds.

**1.03 SUBMITTALS**

- A. See Section 01 3000 - Administrative Requirements, for submittal procedures.
- B. Survey work: Submit name, address, and telephone number of Surveyor before starting survey work.
  - 1. On request, submit documentation verifying accuracy of survey work.
  - 2. Submit a copy of site drawing signed by the Land Surveyor, that the elevations and locations of the work are in compliance with Contract Documents.
  - 3. Submit surveys and survey logs for the project record.
  - 4. Submit final "As-Built Survey" for Owner records and USDA closeout requirements.
- C. Cutting and Patching: Submit written request in advance of cutting or alteration that affects:
  - 1. Structural integrity of any element of Project.
  - 2. Efficiency, maintenance, or safety of any operational element.
  - 3. Visual qualities of sight exposed elements.

**1.04 QUALIFICATIONS**

- A. For surveying work, employ a land surveyor registered in the State in which the Project is located and acceptable to Architect. Submit evidence of surveyor's Errors and Omissions insurance coverage in the form of an Insurance Certificate. Employ only individual(s) trained and experienced in collecting and recording accurate data relevant to ongoing construction activities,
- B. For field engineering, employ a professional engineer of the discipline required for specific service on Project, licensed in the State in which the Project is located. Employ only individual(s) trained and experienced in establishing and maintaining horizontal and vertical control points necessary for laying out construction work on project of similar size, scope and/or complexity.

**1.05 PROJECT CONDITIONS**

- A. Dust Control: Execute work by methods to minimize raising dust from construction operations. Provide positive means to prevent air-borne dust from dispersing into atmosphere and over adjacent property.
- B. Erosion and Sediment Control: Plan and execute work by methods to control surface drainage from cuts and fills, from borrow and waste disposal areas. Prevent erosion and sedimentation.
  - 1. Minimize amount of bare soil exposed at one time.
  - 2. Periodically inspect earthwork to detect evidence of erosion and sedimentation; promptly apply corrective measures.

- C. Noise Control: Provide methods, means, and facilities to minimize noise produced by construction operations.
  - 1. At All Times: Excessively noisy tools and operations will not be tolerated inside the building at any time of day; excessively noisy includes jackhammers, pneumatic hammers, air-operated nail guns, and diesel engines.
- D. Pollution Control: Provide methods, means, and facilities to prevent contamination of soil, water, and atmosphere from discharge of noxious, toxic substances, and pollutants produced by construction operations. Comply with federal, state, and local regulations.

#### **1.06 COORDINATION**

- A. Coordinate scheduling, submittals, and work of the various sections of the Project Manual to ensure efficient and orderly sequence of installation of interdependent construction elements, with provisions for accommodating items installed later.
- B. Coordinate completion and clean-up of work of separate sections.
- C. After Owner occupancy of premises, coordinate access to site for correction of defective work and work not in accordance with Contract Documents, to minimize disruption of Owner's activities.

### **PART 2 PRODUCTS**

#### **2.01 PATCHING MATERIALS**

- A. New Materials: As specified in product sections; match existing products and work for patching and extending work.
- B. Type and Quality of Existing Products: Determine by inspecting and testing products where necessary, referring to existing work as a standard.

### **PART 3 EXECUTION**

#### **3.01 EXAMINATION**

- A. Verify that existing substrate is capable of structural support or attachment of new work being applied or attached.
- B. Prior to Cutting: Examine existing conditions prior to commencing work, including elements subject to damage or movement during cutting and patching. After uncovering existing work, assess conditions affecting performance of work. Beginning of cutting or patching means acceptance of existing conditions.

#### **3.02 PREINSTALLATION MEETINGS**

- A. Require attendance of parties directly affecting, or affected by, work of the specific section.
- B. Notify Architect and Engineer four days in advance of meeting date.
- C. Prepare agenda and preside at meeting:
  - 1. Review conditions of examination, preparation and installation procedures.
  - 2. Review coordination with related work.
- D. Record minutes and distribute copies within two days after meeting to participants, with two copies to Architect, Engineer, Owner, participants, and those affected by decisions made.

#### **3.03 LAYING OUT THE WORK**

- A. Promptly notify Architect and Engineer of any discrepancies discovered.
- B. Contractor shall locate and protect survey control and reference points as required to complete the Work.
- C. Protect survey control points prior to starting site work; preserve permanent reference points during construction.
- D. Promptly report to Architect the loss or destruction of any reference point or relocation required because of changes in grades or other reasons.

- E. Replace dislocated survey control points based on original survey control. Make no changes without prior written notice to Architect.
- F. Utilize recognized engineering survey practices.
- G. Establish elevations, lines and levels. Locate and lay out by instrumentation and similar appropriate means:
  - 1. Site improvements including pavements; stakes for grading, fill and topsoil placement; utility locations, slopes, and invert elevations.
- H. Maintain a complete and accurate log of control and survey work as it progresses.

#### **3.04 CUTTING AND PATCHING**

- A. Whenever possible, execute the work by methods that avoid cutting or patching.
- B. Perform whatever cutting and patching is necessary to:
  - 1. Complete the work.
  - 2. Fit products together to integrate with other work.
  - 3. Match work that has been cut to adjacent work.
  - 4. Repair areas adjacent to cuts to required condition.
  - 5. Repair new work damaged by subsequent work.
  - 6. Remove and replace defective and non-complying work.
- C. Execute work by methods that avoid damage to other work and that will provide appropriate surfaces to receive patching and finishing. In existing work, minimize damage and restore to original condition.
- D. Restore work with new products in accordance with requirements of Contract Documents.
- E. Patching:
  - 1. Finish patched surfaces to match finish that existed prior to patching. On continuous surfaces, refinish to nearest intersection or natural break. For an assembly, refinish entire unit.
  - 2. Repair patched surfaces that are damaged, lifted, discolored, or showing other imperfections due to patching work. If defects are due to condition of substrate, repair substrate prior to repairing finish.

#### **3.05 PROGRESS CLEANING**

- A. Maintain areas free of waste materials, debris, and rubbish. Maintain site in a clean and orderly condition.
- B. Collect and remove waste materials, debris, and trash/rubbish from site periodically and dispose off-site; do not burn or bury.

#### **3.06 PROTECTION OF INSTALLED WORK**

- A. Protect installed work from damage by construction operations.
- B. Provide special protection where specified in individual specification sections.
- C. Provide temporary and removable protection for installed products. Control activity in immediate work area to prevent damage.
- D. Prohibit traffic from landscaped areas.

#### **3.07 FINAL CLEANING**

- A. Execute final cleaning prior to final project assessment.
- B. Use cleaning materials that are nonhazardous.
- C. Clean debris from area drains and drainage systems.
- D. Clean site; sweep paved areas, rake clean landscaped surfaces.
- E. Remove waste, surplus materials, trash/rubbish, and construction facilities from the site; dispose of in legal manner; do not burn or bury.



**3.08 CLOSEOUT PROCEDURES**

- A. Make submittals that are required by governing or other authorities.
  - 1. Provide copies to Architect and Owner.
- B. Notify Architect and Engineer when work is considered ready for Architect's Substantial Completion inspection.
- C. Submit written certification containing Contractor's Correction Punch List, that Contract Documents have been reviewed, work has been inspected, and that work is complete in accordance with Contract Documents and ready for Architect's and Engineer's Substantial Completion inspection.
- D. Conduct Substantial Completion inspection and create Final Correction Punch List containing Architect's/Engineer's and Contractor's comprehensive list of items identified to be completed or corrected and submit to Architect.
- E. Correct items of work listed in Final Correction Punch List and comply with requirements for access to Owner-occupied areas.
- F. Notify Architect and Engineer when work is considered finally complete and ready for Architect's/Engineer's Substantial Completion final inspection.
- G. Complete items of work determined by Architect/Engineer listed in executed Certificate of Substantial Completion.

**END OF SECTION**

**SECTION 01 7800  
CLOSEOUT SUBMITTALS**

**PART 1 GENERAL**

**1.01 SECTION INCLUDES**

- A. Project record documents.
- B. Warranties and bonds.

**1.02 RELATED REQUIREMENTS**

- A. Section 01 3000 - Administrative Requirements: Submittals procedures, shop drawings, product data, and samples.
- B. Section 01 7000 - Execution and Closeout Requirements: Contract closeout procedures.

**1.03 SUBMITTALS**

- A. Project Record Documents: Submit documents to Architect with claim for final Application for Payment.
- B. Warranties and Bonds:
  - 1. For equipment or component parts of equipment put into service during construction with Owner's permission, submit documents within 10 days after acceptance.
  - 2. Make other submittals within 10 days after Date of Substantial Completion, prior to final Application for Payment.
  - 3. For items of Work for which acceptance is delayed beyond Date of Substantial Completion, submit within 10 days after acceptance, listing the date of acceptance as the beginning of the warranty period.

**PART 2 PRODUCTS - NOT USED**

**PART 3 EXECUTION**

**3.01 PROJECT RECORD DOCUMENTS**

- A. Maintain on site one set of the following record documents; record actual revisions to the Work:
  - 1. Drawings.
  - 2. Specifications.
  - 3. Addenda.
  - 4. Change Orders and other modifications to the Contract.
  - 5. Reviewed shop drawings, product data, and samples.
- B. Ensure entries are complete and accurate, enabling future reference by Owner.
- C. Store record documents separate from documents used for construction.
- D. Record information concurrent with construction progress.
- E. Specifications: Legibly mark and record at each product section description of actual products installed, including the following:
  - 1. Manufacturer's name and product model and number.
  - 2. Product substitutions or alternates utilized.
  - 3. Changes made by Addenda and modifications.
- F. Record Drawings and Shop Drawings: Legibly mark each item to record actual construction including:
  - 1. Field changes of dimension and detail.
  - 2. Details not on original Contract drawings.

**3.02 WARRANTIES AND BONDS**

- A. Obtain warranties and bonds, executed in duplicate by responsible Subcontractors, suppliers, and manufacturers, within 10 days after completion of the applicable item of work. Except for items put into use with Owner's permission, leave date of beginning of time of warranty until Date of Substantial completion is determined.

- B. Verify that documents are in proper form, contain full information, and are notarized.
- C. Co-execute submittals when required.
- D. Retain warranties and bonds until time specified for submittal.
- E. Manual: Bind in commercial quality 8-1/2 by 11 inch three D side ring binders with durable plastic covers.
- F. Cover: Identify each binder with typed or printed title WARRANTIES AND BONDS, with title of Project; name, address and telephone number of Contractor and equipment supplier; and name of responsible company principal.

**END OF SECTION**

**PROPOSAL  
AND SPECIFICATIONS**

**FOR**

**COLLETON COUNTY  
MIDDLE SCHOOL PAVING**

**WALTERBORO, SOUTH CAROLINA**

Prepared for:

**COLLETON COUNTY SCHOOL DISTRICT  
WALTERBORO, SOUTH CAROLINA**

Prepared by:



**CRANSTON**

**Engineered with Integrity**

January 10, 2022

CEG# 2021-0330

## Table of Contents

DESCRIPTION OF WORK .....	1
NOTICE TO CONTRACTORS .....	2
SPECIAL PROVISIONS .....	4
1. Colleton County Middle School Paving Project Manager .....	5
2. Examination of Proposal or Plans .....	5
3. Section 101 (Definition and Terms) .....	5
4. Section 107 Legal Relations and Responsibility to the Public .....	6
5. Insurance Requirements .....	6
6. Contractor's Liability Insurance .....	7
7. Award of Contract .....	7
8. Claims Procedure .....	7
9. Contractor Activity Work Schedule .....	7
10. Prompt Payment Clause .....	8
11. Qualified Product Listings .....	8
12. Coordination of Utility Relocation Work with Highway Construction .....	8
13. Required Media Notification .....	8
14. Contract Provisions to Require Certification and Compliance Concerning Illegal Aliens .....	9
15. Subletting of Contracts (Specialty Items) .....	9
16. Paving Operations .....	9
17. Retainage .....	9
18. Rate of Application .....	10
19. Dressing of Shoulders .....	10
20. Cement Modified Recycled Base .....	10
21. Transportation and Delivery of Mixes .....	10
22. Sloped Edge Longitudinal Shoulder Joints .....	10
23. Manual on Uniform Traffic Control Devices .....	10
24. Traffic Control .....	11
25. Erosion Control Measures .....	21
26. Permanent Grassing for Small Projects .....	21
27. Removal of Existing Asphalt Pavement Before Patching .....	21
28. Asphalt Binder and Additives .....	21
29. Asphalt Inspection and Material Testing .....	21
30. Basis of Award .....	21
SUPPLEMENTAL SPECIFICATIONS .....	22
PROPOSAL SECTION .....	23
PROPOSAL ITEMS AND QUANTITIES .....	51
PROPOSAL FORM .....	52
CERTIFICATION FORM .....	53
NOTICE OF AWARD .....	54
AGREEMENT .....	55

PERFORMANCE BOND ..... 58  
LABOR AND MATERIAL PAYMENT BOND..... 60  
PROJECT PLANS ..... 64



---

I certify that this Proposal was  
compiled under my supervision

## **COLLETON COUNTY MIDDLE SCHOOL PAVING**

### **DESCRIPTION OF WORK**

The scope of work consists of the removal of the existing asphalt surface, paving, signage, and striping. All areas will be paved 2 inches thick, per detail. Finished grades shall match existing – provide positive drainage. Signage shall be salvaged or replaced in kind. The work will be performed at the Colleton County Middle School located at 1379 Tuskegee Airmen Drive, Walterboro, South Carolina 29488. Traffic control and other incidental items shall be included as shown in the specifications.

## **COLLETON COUNTY MIDDLE SCHOOL PAVING NOTICE TO CONTRACTORS**

Notice is hereby given that sealed proposals for parking lot improvements for COLLETON COUNTY MIDDLE SCHOOL will be received by Colleton County School District – District Office (Attn: Kenny Blakeney, Director of Building & Grounds located at **500 Forest Circle, Walterboro, SC 29488** until 11:00 a.m. (Local Time) February 8, 2022, and then publicly opened and held for further evaluation by the Colleton County School District until an award is made.

Description of work to be done: See Page #1. Work shall be completed between April 14 and April 25, 2022 after the issued Notice to Proceed and the work at Thunderbolt Career and Technology Center is completed.

This project is to be constructed under the South Carolina Department of Transportation Standard Specifications, Highway Construction, Edition 2007, and the following Special Provisions.

A 100% performance bond and 100% payment bond will be required.

The Proposal for the work may be examined during regular business hours at either the **FWA Group's Office (10 Palmetto Business Park Road, Suite 202, Hilton Head Island, SC 29928**, or **Cranston Engineering Group's Office (14 Westbury Park Way, Suite 202, Bluffton, SC 29910)**

Electronic copies of the Proposals may be obtained by contacting Dale Strecker, AIA at the FWA Group – [d.strecker@fwagroup.com](mailto:d.strecker@fwagroup.com).

All questions shall be submitted in writing to: Matt Randall, PE - [mrandall@cranstonengineering.com](mailto:mrandall@cranstonengineering.com) not less than 5 days before date set for receipt of bids.

The envelope shall be plainly marked with the bidder's name, the project title: **Colleton County Middle School Paving**, Contractor's South Carolina License number, and the date and time for the opening of bids. It is the bidder's sole responsibility to ensure that its bid is received prior to the bid deadline. Any bid received after the scheduled closing time for receipt of bids shall be returned to the bidder unopened. At the time set forth in the Notice for the opening of bids, the sealed bids will be privately opened and evaluated at the place indicated in this Notice.

All proposals otherwise submitted may be rejected as irregular. Only sealed bids will be considered. The right is reserved to reject any or all proposals and waive any technicalities.

All bids (and supporting documents) will be retained by the Colleton County School District General Manager and guaranteed for sixty (60) days from the date the bid is received, and no bids will be received, nor will any Contractor be allowed to withdraw a bid after the opening hour commences.

All bidders must comply with the President's executive Order Numbers 11246 and 1137 which prohibit discrimination in employment regarding race, creed, color, sex, or national origin. All bidders must comply with Title VI of the Civil Rights Act of 1964, the Anti-Kickback Act and the Contract Work Hours Standards Act. This also extends to all subcontractors and suppliers. This includes all LEP requirements. Provide a certification of prior work under Executive Order 11246 (Equal Employment Opportunity). Each bidder must make positive efforts to use small and minority



## **COLLETON COUNTY MIDDLE SCHOOL PAVING**

owned business and women business and women business enterprises and provide certification to meet the MBE/WBE "fair share goal/objectives.

**SPECIAL  
PROVISIONS**

# COLLETON COUNTY MIDDLE SCHOOL PAVING

## 1. Colleton County Middle School Paving Project Manager

The Contractor is hereby notified that Cranston Engineering Group, P.C. will act as the Colleton County Middle School Paving Engineer and be the Construction Project Manager (PM).

## 2. Examination of Proposal or Plans

Plan holders desiring further information or interpretation of the Proposal or Plans shall make a written request for such information to Colleton County Middle School Paving Engineer no later than 5 calendar days prior to the bid opening date for the contract. E-mails are accepted at [mrandall@cranstonengineering.com](mailto:mrandall@cranstonengineering.com) or delivered by 5:00 p.m. on this date.

Correspondence can be mailed to the following address:

Cranston Engineering Group, P.C.  
14 Westbury Park Way, Suite 202  
Bluffton, SC 29910

The contact person for Cranston Engineering Group, P.C. is:

Matt Randall, PE  
Project Manager  
(843) 352-7770 (Office Phone)  
[mrandall@cranstonengineering.com](mailto:mrandall@cranstonengineering.com)

Modifications to the Proposal or Plans will be made by addendum only. A copy of each addendum will be mailed/e-mailed to the plan holders.

**NOTE:** All required bonds shall be in the name of Colleton County School District, NOT in the name of the South Carolina Department of Transportation.

## 3. Section 101 (Definition and Terms)

Delete Paragraph 101.3.27 in its entirety and replace with the following:

"101.3.27 Engineer. The Engineer is the Colleton County Middle School Paving Engineer, acting directly or through a duly authorized representative, such representative acting within the scope of particular assigned duties or authority. On this Project the firm of Cranston Engineering Group, P.C., hereinafter referred to as "Project Manager (PM)" shall function as the Engineers duly authorized representative with authority as described in Section 105, "CONTROL OF WORK", of the Standard Specifications for Highway Construction, latest edition. Any reference to the Department or The South Carolina Department of Transportation found in the Standard Specifications, Contract Documents, Special Provisions, Bid Bond, Standard Drawings, etc. shall be interpreted as Cranston Engineering Group, P.C., the Project Manager, and/or Colleton County School District as applicable.

## COLLETON COUNTY MIDDLE SCHOOL PAVING

### 4. Section 107 Legal Relations and Responsibility to the Public

Section 107. 18 (Responsibility for Claims, Etc.)

In the first sentence, add the words "the Colleton County School District, Cranston Engineering Group, P.C., the Project Manager's (PM) representative and/or Engineer" after the word "Department."

### 5. Insurance Requirements

Refer to Section 103.8 of the Standard Specifications Edition 2007 shall apply and add the following supplementary insurance provisions:

A letter of intent from the insurance company or a Certificate of Insurance, acceptable to the Colleton County School District shall be submitted with the Contractor's bid proposal. The letter of intent or Certificate of Insurance shall reflect that the above requirements will be satisfied. **Any proposal that is submitted without a properly completed Letter of Intent or Certificate of Insurance may be considered irregular and may be rejected.**

If the bidder elects to submit a Letter of Intent instead of a Certificate of Insurance, the form furnished along with this proposal may be used for the Letter of Intent. Failure to use the form furnished by the Colleton County School District may result in the bid being declared irregular and the bid may be rejected. The properly completed Letter of Intent may be submitted with the proposal.

A Certificate of Insurance must be submitted to the Project Manager (PM) within ten (10) days of the bid opening. The contract will not be awarded until all necessary insurance requirements have been met.

The Certificate of Insurance shall include Colleton County School District as an additional insured. The authorized insurance company shall provide a Waiver of Subrogation in all policies maintained by the Insured for the performance of the Contract.

The Certificate of Insurance shall provide that the policy cannot be changed to the extent that limits are decreased, canceled or non-renewed without thirty (30) days notice to the Colleton County School District and the (PM). If the Contractor's Insurer changes or cancels the policy, the Contractor shall procure and maintain the required coverage from another Insurer and shall provide a Certificate of Insurance from the new company. Failure to provide coverage from a new company will be grounds to declare a firm in default of the Contract.

Criteria, which shall be necessary in order for Insurance Company or Companies to be deemed satisfactory by the Colleton County School District, shall include, but not be limited to the following:

1. The above required insurance shall be written a Company or Companies licensed in the areas of required coverage by the Chief Insurance Commissioner of the

## COLLETON COUNTY MIDDLE SCHOOL PAVING

South Carolina Department of Insurance.

2. The Insurance Company or Companies shall be assigned a rating of "B" or better by A.M. Best Company on its most recent Best's Insurance Report. The Colleton County School District considers the "ACORD Certificate of Insurance" as an acceptable form of certificate.

### 6. Contractor's Liability Insurance

Refer to Section 103.8 of the Standard Specifications Edition 2007 shall apply and add the following supplementary insurance provisions:

Delete the second sentence in paragraph 4.

Delete the third sentence in paragraph 5, and replace it with the following sentence:

Ensure that all policies contain a provision that coverage afforded under the policies cannot be cancelled or reduced by the Contractor until at least 30 days prior written notice has been provided to Colleton County School District and that the policies cannot be cancelled for non-payment of premiums until at least 10 days prior written notice has been provided to Colleton County School District. Send Notice of Cancellations to Matt Randall, Project Manager, Cranston Engineering Group, P.C., 14 Westbury Park Way, Suite 202, Bluffton, SC 29910.

Add the following as paragraph 6 at the end of Subsection 103.8.

By execution of the contract, the Contractor accepts the responsibility to provide the liability insurance policies and endorsements as specified herein.

Failure of Colleton County School District to identify a deficiency in the Certificate of Insurance submitted by the Contractor's insurance agent as evidence of the specified insurance or to request other evidence of full compliance with the liability insurance specified shall not be construed as a waiver of the Contractor's obligation to provide and maintain the required insurance for the duration of the contract.

### 7. Award of Contract

Subsection 103.2 of the Standard Specifications Edition 2007 is amended to allow sixty (60) days for the award of a contract after the opening of proposals.

### 8. Claims Procedure

See attached Supplemental Specification dated **January 1, 2021**. For this project, the Colleton County School District will appoint a Dispute Review sub-committee consisting of 3 members of the committee to evaluate the claim. The general procedures for preparation and submittal of the claim can be seen in the Supplemental Specifications. (Claim Procedure)

### 9. Contractor Activity Work Schedule

## COLLETON COUNTY MIDDLE SCHOOL PAVING

Level 1 – Minimal Schedule Requirement shall be revised as follows:

Provide to the Colleton County Middle School Paving Project Manager a four-week look-ahead schedule identifying planned weekly work activities. Update the schedule every two weeks. **All updates shall be received at least 48 hours prior to the scheduled work activity.** The look-ahead schedule allows the PM to schedule construction engineering and inspection personnel. Colleton County School District and its Project Manager will not be responsible for delays which may be caused by the contractor's failure to abide by his schedule. Failure to submit the look-ahead schedule as specified may result in the withholding of partial payment estimates.

### 10. Prompt Payment Clause

See attached Supplemental Specification dated **July 1, 2017**.

### 11. Qualified Product Listings

All references to "Approval Sheet" or "Approval Policy" are to be replaced with "Qualified Products Listings (QPL)" and "Qualified Products Policies (QPP)" respectively. This change includes all references in the SCDOT Standard Drawings, SCDOT Standard Specifications, SCDOT Supplemental Specifications, SCDOT Special Provisions, SCDOT Supplemental Technical Specifications, SCDOT Internet and Intranet websites, and all other documents produced by SCDOT.

### 12. Coordination of Utility Relocation Work with Highway Construction

As it is not economically feasible to complete the rearrangement of all utility conflicts in advance of the highway construction, such rearrangements may be underway concurrently with construction.

**It shall be the responsibility of the contractor to inspect the site for potential utility conflicts.**

It is the responsibility of the Contractor to call Palmetto Utility Protection Service at 811 or 1: 888-721-7877 three (3) days prior to work so that existing utilities can be properly marked

### 13. Required Media Notification

Contractors are encouraged to co-operate with the news media since all projects are constructed with public funds. Because the scope of this project will cause disruption of normal traffic flow, the Contractor is required to notify the public, in a timely manner, of disruptive activities such as lane closures.

The Contractor is required to utilize area media to accomplish public notification of traffic disruptions.

The Contractor is required to deal directly with the news media and all reasonable efforts should be made to co-operate with the media. However, the safety, security and construction schedule on site should not be disrupted in order to accomplish this. The

## COLLETON COUNTY MIDDLE SCHOOL PAVING

Contractor may co-ordinate these activities with and receive guidance from the SCDOT Public Affairs Office.

### 14. Contract Provisions to Require Certification and Compliance Concerning Illegal Aliens

By submission of this bid, the bidder as the prime contractor does hereby agree:

1. to certify its compliance with the requirements of Chapter 14 of Title 8 of the S.C. Code of Laws regarding Unauthorized Aliens and Public Employment;
2. to provide SCDOT with any documents required to establish such compliance upon request; and
3. to register and participate and require agreement from subcontractors and sub-subcontractors to register and participate in the federal work authorization program to verify the employment authorization of all new employees, or to employ only workers who supply the documents required pursuant to S.C. Code 8-14-20(8)(2).

### 15. Subletting of Contracts (Specialty Items)

The following items of work, when not performed by the Prime Contractor, will be designated as Specialty Items in all contracts in which the item does not constitute thirty percent (30%) or more of the original contract value:

Pavement Markings	Permanent Roadway Signs
Guardrail	Signalization
Milling Asphalt Pavement	Electrical/Lighting
Grassing	Specialized Retaining Walls
Landscaping	Fencing
Erosion Control	Right of Way Surveying
Permanent Construction Signs	Railroad Track Work
Utilities	Jack and Boring
Contaminated Soil & Tank Removal	Bridge Floor Grooving Bridge
Barrier Walls	Milled Rumbled Strips
Traffic Count Stations	Buildings
Drilled Shafts & Casings	Navigational Lighting
Pier Fender Systems	Sound Barrier Walls

### 16. Paving Operations

The asphalt overlay shall be applied in two separate and distinct operations, each operation representing about one-half of the roadway width and traffic shall be maintained continuously. Unless otherwise directed by the Engineer, paving operations shall be scheduled such that the length of the longitudinal joint exposed to traffic shall not extend beyond the length of pavement placed in one normal day's operation before dropping back to bring the adjacent lane forward.

### 17. Retainage

## COLLETON COUNTY MIDDLE SCHOOL PAVING

If the Contractor's progress is judged to be delinquent or portions of the work are defective, Colleton County School District reserves the right to withhold retainage. The total amount retained will be sufficient to cover anticipated liquidated damages and the cost to correct defective work.

### 18. Rate of Application

The pounds per square yard specified are set up as an average rate of application. The Engineer may direct variations wherever conditions warrant.

### 19. Dressing of Shoulders

Prior to the placement of asphalt concrete mixtures on existing roadways, the Contractor will be required to remove any vegetation adjacent to the edge of pavement which impedes the placement the asphalt mixture to the specified width. After the asphalt mixture has been placed, the Contractor shall blade the disturbed material to the extent that the shoulder is left in a neat and presentable condition. Any excess material shall be removed from the project. No direct payment shall be made for this work, but the costs shall be included in the price of other items of work.

### 20. Cement Modified Recycled Base

See attached Supplemental Technical Specification SC-M-306.  
Curing Method 4: Surface Treatment and Surface Planing shall be utilized as the curing method for all roads in this contract. Section 301.4.13 Maintenance of the Standard Specifications shall be revised to include the following:

"Once the minimum 72-hour curing process is complete, the contractor will be required within 21 calendar days to place the final asphalt riding surface.

### 21. Transportation and Delivery of Mixes

See attached Supplemental Specification dated **July 1, 2010**.

### 22. Sloped Edge Longitudinal Shoulder Joints

See attached Supplemental Specification dated **July 1, 2019**.

### 23. Manual on Uniform Traffic Control Devices

The Contractor is advised that all work involving design or installation of traffic control devices, including but not limited to signs, pavement markings, elements of work zone traffic control, signals, etc., shall be in compliance with the FHWA's Manual on Uniform Traffic Control Devices (MUTCD), latest edition. The latest edition is defined as the edition that the Traffic Engineering Division of SCDOT recognizes as having been officially adopted (Engineering Directive, Memorandum 19) at the time the project is let, unless stated otherwise in the Special Provisions.



# COLLETON COUNTY MIDDLE SCHOOL PAVING

## 24. Traffic Control

The Contractor shall execute the item of Traffic Control as required by the Standard Specifications, the plans, the Standard Drawings for Road Construction, these special provisions, all supplemental specifications, the MUTCD, and the Engineer. This is an amendment to the Standard Specifications to require the following:

### **GENERAL REGULATIONS –**

These special provisions shall have priority to the plans and comply with the requirements of the MUTCD and the standard specifications. Revisions to the traffic control plan through modifications of the special provisions and the plans shall require approval by the department. Final approval of any revisions to the traffic control plan shall be pending upon review by Colleton County School District.

Install and utilize changeable message signs in all lane closures installed on high volume high-speed multilane roadways. Use of changeable message signs in lane closures installed on low volume low speed multilane roadways is optional unless otherwise directed by the plans and the Engineer. Install and use a changeable message sign within a lane closure set-up as directed by the *Standard Drawings for Road Construction*. When a lane closure is not present for any time to exceed 24 hours, remove the changeable message sign from the roadway. Place the sign in a predetermined area on the project site, as approved by the Engineer, where the sign is not visible to passing motorists. The preprogrammed messages utilized shall be in accordance with the *Standard Drawings for Road Construction* when used as part of the traffic control set-up for lane closures. Only those messages pertinent to the requirements of the traffic control situation and the traffic conditions are permitted for display on a changeable message sign at all times. At no time will the messages displayed on a changeable message sign duplicate the legends on the permanent construction signs.

During operation of changeable message signs, place the changeable message sign on the shoulder of the roadway no closer than 6 feet between the sign and the near edge of the adjacent travel lane. When the sign location is within 30' of the near edge of a travel lane open to traffic, supplement the sign location with no less than 5 portable plastic drums placed between the sign and the adjacent travel lane for delineation of the sign location. Install and maintain the drums no closer than 3 feet from the near edge of the adjacent travel lane. This requirement for delineation of the sign location shall apply during all times the sign location is within 30' of the near edge of a travel lane open to traffic, including times of operation and non-operation. Oversized cones are prohibited as a substitute for the portable plastic drums during this application.

**All signs mounted on portable sign supports shall have a minimum mounting height of 5' from the bottom of the sign to the ground. All signs mounted on ground mounted u-channel posts or square steel tube posts shall have a minimum mounting height of 7' from the bottom of the sign to the grade elevation of the near edge of the adjacent travel lane or sidewalk when a sidewalk is present.**

**On multilane primary routes, avoid placement of signs mounted on portable sign**

## COLLETON COUNTY MIDDLE SCHOOL PAVING

supports within paved median areas utilized for two-way left turns unless otherwise directed by the RCE.

When mounting signs on multiple ground mounted sign supports, ensure that each post is of the same type. Combining and installing both ground mounted u-section and square steel tube posts within the same sign assembly is prohibited.

When mounting signs on ground mounted u-section or square steel tube posts, utilize either a sign support / ground support post combination with an approved breakaway assembly or a single direct driven post for each individual sign support of a sign assembly installation. Do not combine a sign support/ ground support post combination and a direct driven post on the same sign assembly installation that contains two or more sign supports. Regarding sign support / ground support post combination installations, ensure that post lengths, stub heights and breakaway assemblies comply with the manufacturer's requirements and specifications. Use approved breakaway assemblies found on the *Approved Products List for Traffic Control Devices in Work Zones*.

Temporary "Exit" signs (M1025-00) shall be located within each temporary gore during lane closures on multilane roadways. Mount these signs a minimum of 7' from the pavement surface to the bottom of the sign in accordance with the requirements of the MUTCD.

When covering signs with opaque materials, the Department prohibits attaching a covering material to the face of the sign with tape or a similar product or any method that will leave a residue on the retroreflective sheeting. Residue from tape or similar products, as well as many methods utilized to remove such residue, damages the effective reflectivity of the sign. Therefore, contact of tape or a similar product with the retroreflective sheeting will require replacement of the sign. Cost for replacement of a sign damaged by improper covering methods will be considered incidental to providing and maintaining the sign; no additional payment will be made.

**Overlays are prohibited on all rigid construction signs. The legends and borders on all rigid construction signs shall be either reversed screened or direct applied.**

Signs not illustrated on the typical traffic control standard drawings designated for permanent construction signs shall be considered temporary and shall be included in the lump sum price bid item for "Traffic Control" unless otherwise specified.

Install "Grooved Pavement" signs (W8-15-48) supplemented with the "Motorcycle" plaque (W8-15P-30) in advance of milled or surface planed pavement surfaces. On primary routes, install these signs no further than 500 feet in advance of the beginning of the pavement condition. On interstate routes, install these signs no less than 500 feet in advance of the beginning of the pavement condition.

Install two sign assemblies at each sign location, one on each side of the roadway, on multilane roadways when the pavement condition is present. Install these signs immediately upon creation of this pavement condition and maintain these signs

## COLLETON COUNTY MIDDLE SCHOOL PAVING

until this pavement condition is eliminated.

**Install "Steel Plate Ahead" signs (W8-24-48) in advance of an area of roadway where temporary steel plates are present. Install these signs no further than 300 feet in advance of locations where steel plates are present. On multilane roadways, comply with the same guidelines as applied to all other advance warning signs and install two sign assemblies at each sign location, one on each side of the roadway, when roadway conditions warrant. Install these signs immediately upon installation of a temporary steel plate and maintain the signs until the temporary steel plates are removed.**

Install and maintain any necessary detour signing as specified by the typical traffic control standard drawings designated for detour signing, Part VI of the MUTCD, these Special Provisions, and the Engineer. The lump sum price bid item for "Traffic Control" includes payment for installation and maintenance of the detour signing.

The Contractor shall maintain the travel patterns as directed by the traffic control plans and shall execute construction schedules expeditiously. The Contractor shall provide the Resident Engineer with no less than a two-week prior notification of changes in traffic patterns.

**During nighttime flagging operations, flaggers shall wear a safety vest and safety pants that comply with the requirements of ANSI/ ISEA 107 standard performance for Class 3 risk exposure, latest revision, and a fluorescent hard hat. The safety vest and the safety pants shall be reflectorized, and the color of the background material of the safety vest and safety pants shall be fluorescent orange-red or fluorescent yellow-green.**

**During nighttime flagging operations, the contractor shall illuminate each flagger station with any combination of portable lights, standard electric lights, existing streetlights, etc., that will provide a minimum illumination level of 108 Lx or 10fc.**

During nighttime flagging operations, supplement the array of advance warning signs with a changeable message sign for each approach. These changeable message signs are not required during daytime flagging operations. Install the changeable message signs 500' in advance of the advance warning sign arrays. Messages should be "Flagger Ahead" and "Prepare to Stop".

**During sidewalk repair operations, the Department requires lane closures at all times where the sidewalk is adjacent to the travel lanes of a roadway opened to traffic, unless otherwise specified by these special provisions. Maintain lane closure restrictions at all times unless otherwise directed by these special provisions.**

**During surface Planing and milling operations, grade elevation differences greater than 1 inch in areas with pavements composed of hot mixed asphalt (HMA) base courses, intermediate courses or surface courses and Portland cement concrete are PROHIBITED unless otherwise directed by the Department. However, during surface planing and milling operations for removal of Open-Graded Friction**

## COLLETON COUNTY MIDDLE SCHOOL PAVING

**courses ONLY, a grade elevation difference of 1½ inches between adjacent travel lanes opened to traffic may exist unless otherwise directed by the Department.**

Supplement and delineate the shoulder edges of travel lanes through work zones with traffic control devices to provide motorists with a clear and positive travel path. Utilize portable plastic drums unless otherwise directed by the Department. Vertical panels may be used where specified by the plans and directed by the RCE. The installation of traffic control devices is required in all areas where those areas immediately adjacent to a travel lane open to traffic have been altered in any manner by work activities, including but not limited to activities such as grading, milling, etc. Install the traffic control devices immediately upon initiating any alterations to the areas immediately adjacent to or within 15 feet of the near edge line of the adjacent travel lane. When sufficient space is available, place the traffic control devices no closer than 3 feet from the near edge of the traffic control device to the near edge line on the adjacent travel lane. When sufficient space is unavailable, place the traffic control device at the maximum distance from the near edge of the adjacent travel lane available.

### **LANE CLOSURE RESTRICTIONS**

**The lane closure restrictions stated below are project specific, for all other restrictions, see supplemental specification, "Restrictions", dated January 3, 2013.**

The Contractor shall install all lane closures as directed by the Standard Specifications for Highway Construction (Edition of 2000), the Standard Drawings for Road Construction, these special provisions, the MUTCD, and the Engineer. The Contractor shall close the travel lanes of two-lane two-way roadways by installing flagging operations. The Contractor shall close the travel lanes of multilane roadways as directed by the typical traffic control standard drawings designated for lane closures on primary routes.

**The Department prohibits lane closures on primary routes during any time of the day that traffic volumes exceed 800 vehicles per hour per direction. The Department reserves the right to suspend a lane closure if any resulting traffic backups are deemed excessive by the Engineer. Maintain all lane closure restrictions as directed by the plans, these special provisions, and the Engineer.**

**Flagging operations are considered to be lane closures for two-lane two-way operations and shall be subject to all restrictions for lane closures as specified by this contract.**

**Lane closures, including flagging operations, are restricted to maximum distances of 2 miles. Install all lane closures according to the typical traffic control standard drawings. On occasions when daytime lane closures must be extended into the nighttime hours, substitute the nighttime lane closure standards for the daytime lane closure standards.**

**The Department reserves the right to suspend a lane closure if any resulting traffic backups are deemed excessive by the Engineer. Maintain all lane closure restrictions as directed by the Standard Specifications, these special provisions,**

## COLLETON COUNTY MIDDLE SCHOOL PAVING

and the Engineer.

Installation and maintenance of a lane closure is **PROHIBITED** when the Contractor is not actively engaged in work activities specific to the location of the lane closure unless otherwise specified and approved by the Engineer. The length of the lane closure shall not exceed the length of roadway anticipated to be subjected to the proposed work activities within the work shift time frame or the maximum lane closure length specified unless otherwise approved by the Engineer. Also, the maximum lane closure length specified does not warrant installation of the specified lane closure length when the length of the lane closure necessary for conducting the work activity is less.

The length and duration of each lane closure, within the specified parameters, shall require approval by the Engineer prior to installation. The length and duration of each lane closure may be reduced by the Engineer if the work zone impacts generated by a lane closure are deemed excessive or unnecessary.

The presence of temporary signs, portable sign supports, traffic control devices, trailer mounted equipment, truck mounted equipment, vehicles, and vehicles with trailers relative to the installation or removal of a closure, and personnel are prohibited within the 15 to 30 foot clear zone based upon the roadway speed limit during the prohibitive hours for lane closures specified by these special provisions.

### **TYPICAL TRAFFIC CONTROL STANDARD DRAWINGS -**

The typical traffic control standard drawings of the "Standard Drawings for Road Construction", although compliant with the MUTCD, shall take precedence over the MUTCD. The typical traffic control standard drawings of the "Standard Drawings for Road Construction" shall apply to all projects let to contract.

Install the permanent construction signs as shown on the typical traffic control standard drawings designated for permanent construction signing.

### **ADDENDUMS**

(Addendums to the "2001 Standard Specifications for Highway Construction")

#### **(A) Construction (Sub-section 601.4) -**

##### **Sub-section 601.4.2 Construction Vehicles (paragraph 2)-**

When working within the rights-of-way of access-controlled roadways such as Interstate highways, the Contractor's vehicles may only change direction of travel at interchanges. These vehicles are prohibited from crossing the roadway from right side to median or vice versa. Use a flagger to control the Contractor's vehicles when these vehicles attempt to enter the roadway from a closed lane or the median area. Ensure that the flagger does not stop traffic, cause traffic to change lanes, or affect traffic in any manner. The Contractor's vehicles may not disrupt the normal flow of traffic or enter the travel lane of the roadway until a sufficient gap is present.

The Contractor shall have flaggers available to control all construction vehicles entering or crossing the travel lanes of secondary and primary routes. The RCE shall determine the necessity of these flaggers for control of these construction vehicles. The RCE shall

## COLLETON COUNTY MIDDLE SCHOOL PAVING

consider sight distance, vertical and horizontal curves of the roadway, prevailing speeds of traffic, frequency of construction vehicles entering or crossing the roadway, and other site conditions that may impact the safety of the workers and motorists when determining the necessity of these flaggers. Ensure that these flaggers do not stop traffic, cause traffic to change lanes, or affect traffic in any manner. The Contractor's vehicles may not disrupt the normal flow of traffic or enter the travel lane of the roadway until a sufficient gap is present.

When working within the rights-of-way of access-controlled roadways with posted regulatory speed limits of 55 MPH or greater and average daily traffic volumes (ADT) of 10,000 vehicles per day or greater, i.e., Interstate highways, all construction and work vehicles possessing any one or more of the vehicular characteristics listed below are only permitted to enter and exit a right or left shoulder work area during the presence of active lane closures unless otherwise directed by the RCE. These vehicles are not permitted to enter or exit these work areas without the presence of active lane closures unless otherwise directed by the RCE. Shoulder closures are unacceptable and insufficient methods for control of traffic at ingress / egress areas for these vehicles. The restrictive vehicular characteristics include the following:

- Over six (6) tires
- Tandem rear axles
- A base curb weight greater than 8000 lbs.
- A gross vehicular weight greater than 12000 lbs. unless performing duties as a shadow vehicle while supporting a truck mounted attenuator
- A trailer in tow except under the following conditions:
  - Trailers transporting traffic control devices (including but not limited to standard and 42" oversized traffic cones, portable plastic drums, signs, portable sign supports, u-channel and square steel tube signposts) relative to the installation of lane closures, shoulder closures or other traffic control operations approved by the RCE
  - Trailer mounted traffic control devices (including but not limited to advance warning arrow panels, changeable message signs, temporary traffic signals, highway advisory radios, work zone intelligent transportation systems and trailer towed truck mounted attenuators)

### **(B) Construction (Sub-section 601.4) -**

#### **Sub-section 601.4.2 Construction Vehicles - Auxiliary Warning Lights for Vehicles and Equipment -**

Supplement all construction and/or construction-related vehicles and equipment that operate in a stationary or mobile work zone within or adjacent to a roadway within the highway rights-of-way with AMBER or YELLOW colored high intensity rotating or strobe type flashing auxiliary warning light devices. Utilize, install, operate and maintain a single or multiple lighting devices as necessary to provide visibility to approaching motorists.

All auxiliary warning light models shall meet *Society of Automotive Engineers (SAE)* Class standards and SAE Standard J575 relative to *Tests for Motor Vehicle Lighting*

## COLLETON COUNTY MIDDLE SCHOOL PAVING

*Devices and Components* and these specifications. The amber/yellow color of the dome/lens of an auxiliary warning light device shall meet SAE Standard J578 for amber/yellow color specifications.

Auxiliary warning lights with parabolic reflectors that rotate shall rotate around a halogen lamp at a rate to produce approximately 175 flashes per minute. The parabolic reflector shall produce a minimum 80,000 candle power and a minimum 54,000 candela through an SAE Standard J846 approved amber dome.

Equip strobe type flashing auxiliary warning light devices with photosensitive circuit controls to adjust the lighting intensity in response to changes in ambient light conditions such as from day to night. These lights shall have a double-flash capability rated at approximately 80 double flashes per minute and produce a minimum 24 joules of flash energy at the highest power level setting.

Acceptable auxiliary warning light models shall provide sufficient light output to be clearly recognizable at a minimum distance of 1750 feet.

Mount all auxiliary warning light devices intended to function as the auxiliary warning light system or as an element thereof on vehicles and equipment at locations no less than 3 feet above the ground and in conspicuous locations to provide visibility to approaching motorists.

Auxiliary warning light devices and/or models that mount in the locations of the standard vehicle lighting system are unacceptable as the specified auxiliary warning light system due to restrictive simultaneous visibility capabilities from multiple sight angles. However, auxiliary warning light devices that mount in the standard vehicle lighting system locations are acceptable as supplements to the specified lighting devices mounted in locations that do meet the minimum height requirements and provide simultaneous visibility capabilities from multiple sight angles.

Standard vehicle hazard warning lights are only permitted as supplements to the specified auxiliary warning light devices.

### **(C) Category I Traffic Control Devices (Section 603)-**

**\*\*\* (Effective on all projects let to contract after May 1, 2010)**

#### **Sub-section 603.2.2 Oversized Traffic Cones (paragraph 6)-**

Reflectorize each oversized traffic cone with 4 retroreflective bands: 2 orange and 2 white retroreflective bands. Alternate the orange and white retroreflective bands, with the top band always being orange. Make each retroreflective band not less than 6 inches wide.

Utilize Type III - Microprismatic retroreflective sheeting for retroreflectorization on all projects let to contract after May 1, 2010 unless otherwise specified. Separate each retroreflective band with not more than a 2-inch non-reflectorized area. Do not splice the retroreflective sheeting to create the 6- inch retroreflective bands. Apply the retroreflective sheeting directly to the cone surface. Do not apply the retroreflective sheeting over a pre-existing layer of retroreflective sheeting.

## COLLETON COUNTY MIDDLE SCHOOL PAVING

### Sub-section 603.2.3                      Portable Plastic Drums                      (paragraph 3)-

Reflectorize each drum with Type III - Microprismatic retroreflective sheeting: 2 orange and 2 white retroreflective bands, 6 inches wide on all projects let to contract after May 1, 2010 unless otherwise specified. Alternate the orange and white retroreflective bands with the top band always being orange. Ensure that any non-reflectorized area between the orange and white retroreflective bands does not exceed 2 inches. Do not splice the retroreflective sheeting to create the 6-inch retroreflective bands. Apply the retroreflective sheeting directly to the drum surface. Do not apply the retroreflective sheeting over a pre-existing layer of retroreflective sheeting.

### **(D) Category II Traffic Control Devices (Section 604)-**

**\*\*\* (Effective on all projects let to contract after May 1, 2012)**

### Sub-section 604.2.1                      Type I and Type II Barricades                      (paragraph 3)-

Reflectorize these barricades with Type VIII or IX Prismatic retroreflective sheeting on all projects let to contract after May 1, 2012 unless otherwise specified. Ensure that the retroreflective sheeting has alternate orange and white stripes sloping downward at a 45-degree angle in the direction of passing traffic. The stripes shall be 6 inches wide.

### Sub-section 604.2.2                      Type III Barricades                      (paragraph 3)-

Reflectorize these barricades with Type VIII or IX Prismatic retro reflective sheeting on all projects let to contract after May 1, 2012 unless otherwise specified. Ensure that the retroreflective sheeting has alternate orange and white stripes sloping downward at a 45-degree angle. Apply the sloping orange and white stripes in accordance with the requirements of the Plans, SCOOT Standard Drawings and the MUTCD. The stripes shall be 6 inches wide.

### **(E) Temporary Concrete Barrier (Sub-section 605.2.3.2)-**

### Sub-section 605.2.3.2                      Temporary Concrete Barrier                      (paragraph 6)-

Previously used temporary concrete barrier walls are subject to inspection and approval by the RCE before use. Ensure that previously used temporary concrete barrier walls are in good condition. Defects to a temporary concrete barrier wall that may disqualify a section of wall for use include gouges, cracks, chipped, or spalled areas. A defect that exposes reinforcing steel warrants immediate disqualification. A disqualification grade type defect shall consist of measurements in excess of 1 inch, entirely or partially within the boundaries of the end connection areas and the drainage slot areas as illustrated in the "Standard Drawings for Road Construction", and/or in excess of 4 inches for all areas beyond the end connection areas. To warrant disqualification, these measurements shall exceed the specified dimensions in all three directions, width, height, and depth. A defect that exceeds the specified dimensions in only one or two of the three directions does not warrant disqualification.

Temporary concrete barrier walls with defects less than 6 inches in all three directions, width, height, and depth that do not expose reinforcing steel may be repaired in accordance with the following requirements. Repair is prohibited on temporary concrete barrier walls with defects 6 inches or greater in all three directions, width, height, and depth.

For repair of temporary concrete barrier walls with defects less than 6 inches in all three



## COLLETON COUNTY MIDDLE SCHOOL PAVING

directions, width, height, and depth that do not expose reinforcing steel, repair the defect with a premanufactured patching material specifically fabricated for patching structural concrete. The strength of the patch must meet or exceed the design strength of the class 3000 concrete of the temporary concrete barrier wall. Perform the repair procedures in accordance with all requirements and instructions from the manufacturer of the patch material. Use a bonding compound between the patch material and the concrete unless specifically stated by the manufacturer that a bonding compound is not required. If the manufacturer states that application of a bonding compound is optional, SCOOT requires application of a bonding compound compatible with the patch material. If cracking occurs within the patched area, remove the patch material completely and repeat the repair process.

The contractor shall submit documentation stating all repairs have been conducted in accordance with these requirements prior to installing any temporary concrete barrier walls with repairs. Utilization of temporary concrete barrier walls with repairs shall require approval by the RCE prior to installation.

The Contractor shall submit certification documents for the patch material utilized for repairs to the Engineer prior to placing temporary concrete barrier walls that have been repaired on the project site.

**(F) Truck-Mounted Attenuator (Sub-section 605.4.2.2) –**

**Sub-section 605.2.2.2.3.3                      Color    (paragraph 1)–**

Use industrial grade enamel paint for cover of the metal aspects of the unit. Provide and attach supplemental striping to the rear face of the unit with a minimum Type III high intensity retroreflective sheeting unless otherwise directed by the Department. Utilize an alternating 4 to 8 inch black and 4 to 8 inch yellow 45-degree striping pattern that forms an inverted "V" at the center of the unit that slopes down and to the sides of the unit in both directions from the center.

**(G) Truck-Mounted Attenuator (Sub-section 605.4.2.2) -**

**Sub-section 605.4.2.2                      Truck-Mounted Attenuators                      (paragraph 6)–**

Attach each truck-mounted attenuator to the rear of a truck with a minimum gross vehicular weight (GVW) of 15,000 pounds (actual weight). If the addition of supplemental weight to the vehicle as ballast is necessary, contain the material within a structure constructed of steel. Construct this steel structure to have a minimum of four sides and a bottom to contain the ballast material in its entirety. A top is optional. Bolt this structure to the frame of the truck. Utilize a sufficient number of fasteners for attachment of the steel structure to the frame of the truck to ensure the structure will not part from the frame of the truck during an impact upon the attached truck mounted attenuator. Utilize either dry loose sand or steel reinforced concrete for ballast material within the steel structure to achieve the necessary weight. The ballast material shall remain contained within the confines of the steel structure and shall not protrude from the steel structure in any manner.

**(H) Trailer-Mounted Changeable Message Signs (Sub-section 606.3.2) –**

**Sub-section 606.5                      Measurement    (paragraph 2)–**

Trailer-mounted changeable message signs are included in the lump sum item for Traffic

## COLLETON COUNTY MIDDLE SCHOOL PAVING

Control in accordance with Subsections 107.12 and 601.5 of the "2007 Standard Specifications for Highway Construction". No separate measurement will be made for trailer-mounted changeable message signs unless the contract includes a specific pay item for trailer-mounted changeable message signs. The Contractor shall provide, install, operate, and maintain the trailer-mounted changeable message sign per traffic control set-up as directed by the Plans, the "Standard Drawings for Road Construction", these Special Provisions, the Specifications, and the Engineer.

**Sub-section 606.6 Payment (paragraph 2)**

In addition to Subsections 107.12 and 601.6, the payment for Traffic Control is full compensation for providing, installing, removing, relocating, operating, and maintaining trailer-mounted advance warning arrow panels and trailer-mounted changeable message signs as specified or directed and includes providing the units' primary power source; repairing or replacing damaged or malfunctioning units within the specified time; providing traffic control necessary for installing, operating, and maintaining the units; and all other materials, labor, hardware, equipment, tools, supplies, transportation, incidentals, and any miscellaneous items necessary to fulfill the requirements of the pay item in accordance with the Plans, the Specifications, and other items of the Contract.

**Sub-section 606.6 Payment (paragraph 3)**

Disregard this paragraph unless the Contract includes a specific pay item for trailer-mounted changeable message signs.

**(I) Flagging Operations (Sub-section 610.4.1)**

**Sub-section 610.4.1.1 Flagging Operations (paragraph 1)**

Use a flagging operation to control the flow of traffic when two opposing directions of traffic must share a common travel lane. A flagging operation may be necessary during a lane closure on a two-lane two-way roadway, an intermittent ramp closure or an intermittent encroachment of equipment onto a portion of the roadway. Utilize flagging operations to direct traffic around work activities and maintain continuous traffic flow at reduced speeds when determined to be appropriate by the RCE. As stated above, flagging operations shall direct traffic around the work activities and maintain continuous traffic flow, therefore, stopped traffic shall not be required to stop for time durations greater than those listed below unless otherwise directed by the RCE.

Length of Closure	Maximum Time Duration for Stopped Traffic
1 MILE or LESS	5 Minutes
1 to 2 MILES	7 ½ Minutes

If the work activities require traffic to be stopped for periods greater than 5 to 7 ½ minutes as stated above, consider alternate work methods, conducting work activities during times of lowest traffic volumes such as during the hours of darkness or complete road closure with detour installation.

## COLLETON COUNTY MIDDLE SCHOOL PAVING

**(J) Paving and Resurfacing (Sub-section 611.4.1) -**  
**Sub-section 611.4.1.2 Requirements (paragraph 8)**

Whenever travel lanes with acceptable grade elevation differences are open to traffic, provide "Uneven Lanes" signs (W8-11-48) or "Uneven Pavement" signs (W8-11A-48). Reflectorize these signs with a fluorescent orange colored prismatic retroreflective sheeting unless otherwise specified. Install these signs adjacent to roadways with uneven pavement surfaces between travel lanes or between travel lanes and the adjacent paved shoulders. Install these signs at intervals no greater than 2600 feet.

### **25. Erosion Control Measures**

See attached Supplemental Specification dated **January 1, 2020**.

### **26. Permanent Grassing for Small Projects**

Section 1.3.3 of **SC-M-810 SEEDING** paragraph two is modified as follows: Permanent Grassing for small projects will require HECF-Type 3 on all applications, unless otherwise noted in the plans or specifications.

### **27. Removal of Existing Asphalt Pavement Before Patching**

See attached Supplemental Specification dated **January 1, 2018**.

### **28. Asphalt Binder and Additives**

See attached Supplemental Specification dated **January 1, 2019**.

### **29. Asphalt Inspection and Material Testing**

See SCDOT Construction Manual, Appendix C, Sampling and Testing Procedures.

### **30. Basis of Award**

The bids will be compared on the basis of unit price, as extended, which will include and cover the furnishing of all materials and the performance of all labor requisite or proper and completing of all the work called for under the accompanying contract, and in the manner set forth and described in the specifications.

Where estimated quantities are included in certain items of the proposal, they are for the purpose of comparing bids. While they are believed to be close approximations, they are not guaranteed, and settlement will be made for such items upon the basis of the work as actually executed at the unit prices in the proposal as accepted. In case of error in the extension of prices in a proposal, unit bid prices shall govern.

# **SUPPLEMENTAL SPECIFICATIONS**

January 1, 2018

**ERRATA TO 2007 STANDARD SPECIFICATIONS FOR HIGHWAY CONSTRUCTION**

Make the changes listed below to correct errata in the SDCOT *2007 Standard Specifications for Highway Construction*:

**DIVISION 100 GENERAL PROVISIONS**

**SECTION 101 DEFINITIONS AND TERMS**

**Subsection 101.2 Abbreviations and Acronyms**

Amend the table of **SCDOT OFFICIALS AND OFFICES** as follows:

DELETIONS		REPLACEMENTS	
BDE*	<del>Bridge Design Engineer</del>	PSE*	Preconstruction Support Engineer
BDGE*	<del>Bridge Design Geotechnical Engineer</del>	GDSE*	Geotechnical Design Support Engineer
SHE*	<del>State Highway Engineer</del>	DSE*	Deputy Secretary for Engineering

\*Wherever it appears in the text, replace the deleted abbreviation with the new abbreviation.

**SECTION 102 BIDDING REQUIREMENTS AND CONDITIONS**

**Subsection 102.8 Irregular Bids**

Paragraph 2, item E, first sentence; delete the word "the" after the word "When".

**SECTION 105 CONTROL OF WORK**

**Subsection 105.6 Cooperation with Utilities**

Paragraph 1, last sentence; change the word "THE" to "the".

**DIVISION 200 EARTHWORK**

**SECTION 202 REMOVAL OF STRUCTURES AND OBSTRUCTIONS**

**Subsection 202.5 Measurement**

Paragraph 5, second bullet; change the words "Brick sidewalk" to "Concrete, brick or stone sidewalks".

**SECTION 204 STRUCTURE EXCAVATION**

**Subsection 204.2.1.2 Structure Excavation for Culverts**

Paragraph 1, at the end of the first sentence; change "**Subsection 204.4**" to "**Subsection 204.5**".

**DIVISION 400 ASPHALT PAVEMENTS**

**SECTION 401 HOT MIXED ASPHALT (HMA) PAVEMENT**

**Subsection 401.2.1.2 Liquid Anti-Stripping Agent**

Paragraph 1, first sentence; delete the period at the end of the sentence and add "and SC-M-406".

**Subsection 401.2.5 Material for Full Depth Patching**

Paragraph 1, delete and replace with the following:

**SUPPLEMENTAL SPECIFICATIONS**

"Use an approved SCDOT Intermediate Type C mix for all Full Depth Patching."

**Subsection 401.5 Measurement**

After paragraph 10, add the following paragraph:

- 11 The measurement of Prime Coat is the number of gallons of asphalt material applied to the completed and accepted base course.

**Subsection 401.6 Payment**

After paragraph 12, add the following paragraph:

- 13 "The payment for Prime Coat is at the contract unit price for Prime Coat and includes compensation for all labor, equipment, tools, maintenance, and incidentals necessary to complete that work."

**Subsection 401.6 Payment**

Paragraph 13, **Table of Pay Items**

Change paragraph reference number "13" to "14" and add the following Pay Item:

Item No.	Pay Item	Unit
4010005	Prime Coat	GAL

**SECTION 403 HMA SURFACE COURSE**

**Subsection 403.5 Measurement**

Paragraph 1, first sentence; change "HMA Intermediate Course" to "HMA Surface Course".

**Subsection 403.6 Payment**

Paragraph 1, first sentence; change "HMA Intermediate Course" to "HMA Surface Course".

**SECTION 407 ASPHALT SURFACE TREATMENT – DOUBLE TREATMENT**

**Subsection 407.5 Measurement**

Paragraph 1, first sentence; add the word "is" after "(Double Treatment Type (1, 2, 3, 4, or 5))".

**SECTION 408 ASPHALT SURFACE TREATMENT – TRIPLE TREATMENT**

**Subsection 408.5 Measurement**

Paragraph 1, first sentence; add the word "is" after "(Triple Treatment Type (1 or 2))".

**DIVISION 600 MAINTENANCE AND TRAFFIC CONTROL**

**SECTION 625 PERMANENT PAVEMENT MARKINGS FAST DRY WATERBOURNE PAINT**

**Subsection 625.2.2.4.11 Lead Content**

Paragraph 1, first sentence; change 6% to 0.06%.

**SECTION 627 THERMOPLASTIC PAVEMENT MARKINGS**

**Subsection 627.4.10 Inspection and Acceptance of Work**

Paragraph 2, first sentence; change "period of 90 days" to "period of 180 days".

**Subsection 627.4.10 Inspection and Acceptance of Work**

Paragraph 2, second sentence; change "90-day observation period" to "180-day observation period".

**Subsection 627.4.10 Inspection and Acceptance of Work**

## SUPPLEMENTAL SPECIFICATIONS

Paragraph 3, first sentence; change "90-day period" to "180-day period".

### DIVISION 700 STRUCTURES

#### SECTION 709 STRUCTURAL STEEL

##### **Subsection 709.4.3.5.2 Submittals and Notification**

Paragraph 1, delete the last two sentences and replace them with, "The Department's review and acceptance are required before any field welding will be permitted."

##### **Subsection 709.6.3 Pay Items (page 650)**

Subsection heading number; change subsection heading number from "709.6.3" to "709.6.4".

#### SECTION 712 DRILLED SHAFTS AND DRILLED PILE FOUNDATIONS

##### **Subsection 712.4.4 Dry Construction Method**

Paragraph 2, last sentence in A; change "*Drilled Shaft Report*" to "*Drilled Shaft Log*".

##### **Subsection 712.4.10.4 Excavation Cleanliness**

Paragraph 1, last sentence; change "*Drilled Shaft Report*" to "*Drilled Shaft Log*".

##### **Subsection 712.4.10.6 Shaft Load Test**

Change first paragraph reference number from "2" to "1".

##### **Subsection 712.6.10 Drilled Pile Set-Up**

Insert paragraph reference number "1" to the left of the first paragraph.

#### SECTION 723 DECK JOINT STRIP SEAL

##### **Subsection 723.1 Description**

Insert paragraph reference number "3" to the left of the third paragraph.

#### SECTION 726 BRIDGE DECK REHABILITATION

##### **Subsection 726.4.1 General**

Insert paragraph reference number "1" to the left of the first paragraph.

##### **Subsection 723.4.6 Full Depth Patching (page 790)**

Subsection heading number; change subsection heading number from "723.4.6" to "726.4.6"

##### **Subsection 726.6.8 Concrete Overlay (Latex) or (Portland Cement) (page 802)** Paragraph 2, the equation is changed to $AP=CP \times (ACS/RCS)^2$

#### SECTION 727 CROSSHOLE SONIC LOGGING OF DRILLED SHAFT FOUNDATIONS

##### **Subsection 726.6 Payment (page 807)**

Subsection heading number; change subsection heading number from "726.6" to "727.6"

### DIVISION 800 INCIDENTAL CONSTRUCTION

#### SECTION 805 GUARDRAIL

**Subsection 805.5 Measurement**

Paragraph 4; amend as follows:

"The quantity for the pay item 8053000 Additional Length Guardrail Post is the length of required post installed in excess of the standard length post based on the system being installed, measured by the linear foot (LF), complete, and accepted."

**SECTION 815 EROSION CONTROL**

**Subsection 815.1 Description**

Paragraph 1, first sentence; change "temporary flexible pipe" to "temporary pipe".

**Subsection 815.5 Measurement**

Paragraph 13; delete the first sentence and replace it with the following sentence:  
"The quantity for Temporary Pipe Slope Drains is measured and paid for in accordance with **Subsections 803.5 and 803.6** respectively."

**Subsection 815.5 Measurement**

Delete paragraph 19.

**Subsection 815.6 Payment**

After paragraph 15, add the following paragraph:

- 16 Payment for Removal of Silt Retained by Silt Fence is full compensation for removing and disposing of sediment deposits accumulated by silt fences as specified or directed and includes all materials, labor, equipment, tools, supplies, transportation, and incidentals necessary to fulfill the requirements of the pay item in accordance with the Plans, the Specifications, and other terms of the Contract.

**Subsection 815.6 Payment**

Change original paragraph number "16" to "17".

**Subsection 815.6 Payment**

Pay Item table; change the Unit for Item No. 8156214 to "EA".

**INDEX:**

Amend as follows:

Page I-3, after "Bridge Deck Rehabilitation, measurement and payment:"

Delete page 807.

Page I-12, after "Letting:"

Replace page 19 with page 9.

Page I-13, after "Overhead Sign Structure:"

Replace page 488 with page 495.

Page I-15, after "Proof Rolling:"

Delete page 98.

Page I-18, after "Structural Steel, turned and ribbed bolts:"

Replace page 624 with page 625.

Page I-19, after "Waterproofing, bridge deck:"

Delete page 907.

Page I-20, after "Working Drawings:"

Replace page 543 with page 779.



## Supplemental Specification

January 1, 2021

APPROVED:

Division Administrator

THADDEUS  
W KITOWICZ

Digitally signed by  
THADDEUS W KITOWICZ  
Date: 2020.10.22 14:06:09  
-04'00'

By: \_\_\_\_\_

FEDERAL HIGHWAY ADMINISTRATION

### CLAIMS PROCEDURE

#### 1. Scope of Procedure

The following claims procedure covers all claims for additional time or compensation arising under this contract. The claims procedure is non-binding and is a condition precedent to litigation or any other form of dispute resolution. All communications, testimony, and all documents prepared for this procedure by either party from the time of filing the CERTIFICATE OF CLAIM, per section 105.16.8 of the 2007 Standard of Specifications for Highway Construction, to the conclusion of the procedure shall be deemed to be settlement negotiations and not admissible in litigation or any other dispute resolution procedure. If at the conclusion of this procedure the claim has not been resolved, litigation may be pursued through the South Carolina Circuit Court for Richland County. Contractor waives all rights to a jury trial and agrees that all litigation matters shall be heard non-jury and venue for any action shall be in the South Carolina Circuit Court for Richland County.

#### 2. Continuation of Work

At all times during the pendency of a claim under this procedure, the Contractor shall continue work pursuant to the contract and as directed by the Engineer as provided by the contract. If the Contractor fails to continue work, it may be declared delinquent in its work as provided by §108.08 of the South Carolina Standard Specifications for Highway Construction ("Standard Specifications").

#### 3. Submission of Claim

The notice of claim and claim shall be submitted in accordance with §105.16.7 of the Standard Specifications. The notice of claim does not trigger this claims procedure. The claims procedure is initiated when the Contractor submits a written fully detailed CERTIFICATE OF CLAIM to the Resident Construction Engineer ("RCE"). The Contractor must submit three (3) hard copies and one (1) electronic copy of the Claim to the RCE. The claim shall contain, at a minimum, the information required by §105.16.7 of the Standard Specifications. The RCE shall immediately forward a copy of the claim to the District Engineering Administrator ("DEA") for resolution. If the DEA is unable to resolve the claim within thirty (30) days of receipt, the DEA shall forward it immediately to the Director of Construction ("DOC"), together with documents supporting the Department's position. The DEA shall also submit the supporting documents to the Contractor at this time. The DOC shall investigate the claim and attempt to resolve it by mutual agreement with the Contractor. If it cannot be resolved, then the DOC shall make a decision and forward the decision to the Contractor, no later than sixty (60) days after receipt by the DOC. The Contractor shall notify the DOC within thirty (30) days of receipt of the DOC's decision whether the Contractor accepts or rejects the decision.

For all claims under Fifty Thousand Dollars (\$50,000.00) the DOC's decision shall be final and shall conclude the claims procedure. For the purpose of determining if a time only claim may be submitted to the Board, the value of a time only claim shall be deemed to be the number of days requested multiplied by the contract daily rate for liquidated damages. The Contractor does not have a right to submit claims under \$50,000.00 to the Dispute Review Board. If the Contractor does not accept the DOC's decision on its claim of less than \$50,000.00, then its remedy is litigation in the South Carolina Circuit Court for Richland County as set forth in Paragraph 1 of this Claims Procedure or other mutually agreeable dispute resolution procedures.

For all claims in excess of \$50,000.00, if the Contractor rejects the DOC's decision the DOC shall forward the claim to the Dispute Review Board.

#### **4. Dispute Review Board**

A Standing Dispute Review Board has been established and shall be maintained. The Standing Dispute Review Board shall consist of one member selected by the Department, one member selected by the Director of Heavy and Highway Division of the Associated General Contractors (Carolina's Branch), and a third member selected by the first two members. The third member shall be the chairperson of the Standing Dispute Review Board. The selection of qualified Standing Dispute Review Board members shall be made in accordance with the Dispute Review Board rules and procedures (See Section 6.) Each member shall serve a three (3) year term and the terms shall be staggered. Each member is limited to two (2) terms. All board members shall be neutral and unbiased. No party shall have any *ex parte* communication with any Board Member.

#### **5. Hearing Procedure**

The Contractor shall provide an additional three (3) hard copies of its Claim and three (3) portable storage devices (thumb drives) containing its Claim for the DRB's use. The Department shall provide three (3) hard copies and three (3) portable storage devices (thumb drives) containing its response to the Claim for the DRB's use. The DOC shall send both the Contractor's Claim and the Department's response to the Claim to the DRB within 45 days of the Contractor's rejection of the DOC decision.

Within fifteen (15) days of notice of submission of the claim to the Board, the Contractor may submit to the DOC five (5) written and electronic copies of any additional documentation supporting its claim. The DOC shall immediately forward three (3) copies to the Board, one (1) copy to the DEA, and the DOC will keep one (1) copy.

Within fifteen (15) days of receipt of the Contractor's supplemental documentation, the DEA may submit to the DOC five (5) written and electronic copies of its additional documentation. The DOC shall immediately submit three (3) copies to the Dispute Review Board, one (1) copy to the Contractor, and the DOC will keep one (1) copy.

The Dispute Review Board shall review all documents and notify the parties of what additional documents, if any, it requires. The Dispute Review Board shall schedule a hearing at either party's request or may schedule a hearing at its own discretion. However, if a hearing is requested, it must be held no later than sixty (60) days after the DOC submits the claim to the Dispute Review Board. The location of the hearings shall be determined by the Board. While extensions of these deadlines are discouraged, the Dispute Review Board shall have authority to extend any of the above deadlines for just cause.

The Dispute Review Board shall have full authority to establish guidelines and procedures for the investigation of a claim. The entire process is intended to be flexible and the Board is encouraged to adapt the process to individual circumstances presented by particular disputes.

In the interest of timely resolution of all claims, the Board shall conduct all hearings and issue its final decision within ninety (90) days of receipt of the claim.

The Dispute Review Board Chairperson shall direct all meetings and hearings. Presentation of evidence shall be in accordance with the Dispute Review Board's rules and shall not be bound by judicial rules of evidence. Documents and testimony shall be presented in the order, manner and degree of detail that the Dispute Review Board deems most efficient and probative. Each party shall be allowed to make a brief initial presentation and to rebut any factual assertion by another party; however, the Dispute Review Board shall determine when enough evidence has been presented and it may limit the presentation of any

documentation or testimony that it deems not relevant or redundant. At the Board's option, testimony may be required to be given under oath and the oath shall be administered by the Chairperson.

Legal counsel for either party may be present at meetings or hearings as observers only. If a party intends to have its counsel present at a hearing, it must provide at least ten (10) days' notice prior to the meeting or hearing. Legal counsel may not speak on behalf of a party, unless requested by the Board. Counsel may not examine or cross-examine witnesses, object to questions or statements during meetings or make legal motions or arguments during meetings or hearings. The Board, by majority vote, may suspend legal counsel's privilege to attend meetings or hearings.

The Dispute Review Board shall issue to the Contractor and the Director of Construction a written recommendation with an explanation of the results as soon as reasonably possible following the conclusion of the hearing. However, in no event shall the Board take more than ninety (90) days from receipt of claim to conduct hearings and issue a recommendation. The Board is encouraged to reach a unanimous decision; however, it may provide a majority recommendation. The minority Board Member may provide a written explanation of his position. The Board shall provide further explanation of its decision if requested by either party within ten (10) days of the receipt of the decision. Issuance of the Board's recommendation concludes the claims procedure.

The parties may settle at any time during the procedure. If the dispute is resolved prior to issuance of a recommendation, the DOC shall immediately notify the Board.

Within sixty (60) calendar days of issuance of the Board's recommendation each party shall notify the other in writing whether or not they accept the Board's decision.

If at the conclusion of this procedure the claim has not been resolved, litigation may be pursued in South Carolina Circuit Court for Richland County as set forth in Paragraph 1 of this Claims Procedure.

The Board members shall not be compelled to testify, give any type of statements, nor produce any documents or evidence submitted at the DRB hearing in any subsequent proceedings or litigation.

## **6. Dispute Review Board Rules and Procedures**

### **a. Qualifications of Dispute Review Board Members**

- (1) All Dispute Review Board Members shall have substantial experience in highway or bridge design and construction. This experience may be technical, administrative or legal. The goal is to have a Board with the technical and administrative skills and experience that will promote confidence in its decisions.
- (2) No Dispute Review Board Member shall be employed currently or within the last three (3) years with the Department, any Contractor (currently or in the past pre-qualified with the Department), or any design consultant that has worked for the Department within the last three (3) years.
- (3) No Dispute Review Board Member shall have any financial or ownership interest in any party to the contract nor any design consultant or major subcontractor.

### **b. Selection of Dispute Review Board Members**

The selection process for Dispute Review Board Members shall begin at the appropriate time in order to allow completion of the Member selection by beginning of the term. The selection process shall be as provided in Section 4.

### **c. Replacement of Board Members**

Each party may elect to replace its Board Member at any time with a showing of reasonable justification. The Chairperson of the Board may be replaced at any time with the consent of both parties. If any Board Member is replaced, the new member shall be selected in the same manner in which the original appointment had been made.

If disputes are pending at the end of a member's term, the existing Board shall complete its hearing on the disputes and issue a decision.

d. Costs

Board Members shall be paid a reasonable hourly rate or salary for their services. Each party shall negotiate the fee arrangements with the Member it selects, however, the other party must agree on the rate. Both parties shall agree on the fee arrangement for the Chairperson.

Board Members shall be reimbursed for out-of-pocket expenses including, but not limited to, travel, copying, telephone, clerical services, and mailings. The Board Members shall be allowed reimbursement of actual expenses for meals up to the daily maximums set forth in the Department's Regulations for Reimbursement of Travel and Subsistence Expenses and actual lodging costs provided they stay in hotels approved by the Department and they obtain a government rate. Board Members must provide documentation for all expenses.

The parties shall share all Board Members' fees and expenses equally. The total fees and expenses to hear each claim shall not exceed the following maximum amounts unless otherwise agreed to by both parties in writing (one claim shall constitute all issues submitted to the Dispute Review Board at one (1) time):

<u>Claim Amount</u>	<u>Cumulative Total</u>
\$ 50,000 - \$499,999.99.....	\$15,000.00
\$500,000.00 - \$999,999.99.....	\$25,000.00
\$1 million - \$4,999,999.99.....	\$40,000.00
over \$5 million.....	\$75,000.00

The Department shall pay the Board Members and deduct the Contractor's share from monies owed to the Contractor. If monies owed are not sufficient, the Contractor shall pay the Department directly for its share of the fees and expenses.

July 2017

### PROMPT PAYMENT CLAUSE

(1) Subject to the provisions on retainage provided in Paragraph (2) below, when a subcontractor has satisfactorily performed a work item of the subcontract, the Contractor must pay the subcontractor for the work item within seven (7) calendar days of the Contractor's receipt of payment from SCDOT. A subcontractor shall be considered to have "satisfactorily performed a work item of the subcontract" when the SCDOT pays the Contractor for that work item. In the case of a second or third tier subcontractor, the 7-day time period begins to run when the 1st tier subcontractor receives payment from the Contractor or when the 2nd tier subcontractor receives payment from the 1st tier subcontractor.

(2) The Contractor may withhold as retainage up to five (5%) percent of a subcontractor's payment until satisfactory completion of all work items of the subcontract. "Satisfactory completion of all work items of the subcontract" shall mean when the SCDOT accepts the last work item of the subcontract. The Contractor must release to the subcontractor any retainage withheld within seven (7) calendar days from the date the Contractor receives payment from SCDOT for the last work item of the subcontract or within seven (7) days from SCDOT's acceptance of the last work item of the subcontract, whichever is the latest to occur. However, upon documentation of good cause provided by the contractor and written concurrence by the Director of Construction, the Contractor may continue to withhold the 5% retainage.

(3) Prior to receiving payment of each monthly estimate, the Contractor shall (a) certify to SCDOT that the construction estimate is complete and that its subcontractors have been paid for work covered by previous estimates, for which they are entitled to be paid, in accordance with paragraphs (1) and (2) above, and (b) submit verification that Contractor has received similar certifications or evidence from its subcontractors that lower tier subcontractors have been paid in accordance with paragraph (1). No payment will be made to Contractor unless such documentation/certification is received or SCDOT has issued written approval for delayed payment and required status reports as follows:

(i) The obligation to promptly pay subcontractors (all tiers) or to release retainage does not arise if there is a legitimate subcontract dispute with first tier and/or lower tier subcontractors. If there is a subcontract dispute, the Contractor may submit a written request to SCDOT to approve a delay in payment to the subcontractor which shall explain the nature of the dispute and identify relevant subcontract provisions as support. The explanation may include those reasons set forth in the SC Prompt Pay Act (S.C. Code Section 29-6-40). Payment to the subcontractor shall not be withheld without prior SCDOT written approval.

(ii) Contractor shall submit a status report of the dispute in each monthly progress payment. The status report shall contain:

- justification for the continuation of nonpayment in the form of a pending judicial proceedings, alternate dispute resolution (ADR) process or administrative proceedings, as evidence of why the delay shall continue; or

- a certification that the matter is resolved and payment has been issued to the subcontractor (first tier and/or lower tier subcontractors).

(4) Failure to comply with any of the above provisions shall constitute a material breach of the contract and shall result in one or more of the following sanctions: (1) no further payments to the Contractor unless and until compliance is achieved; (2) monetary sanctions; and/or (3) the Contractor being declared in default and being subject to termination pursuant to Section 108.10 of the Standard Specifications.

(5) Any subcontractor who believes it is due payment in accordance with the Prompt Payment Clause may request information from the servicing Resident Construction Engineer (RCE) as to whether and when payment for the subcontractor's work has been made to the Contractor. If payment has been made to the Contractor, and a subcontractor certifies to the RCE that the subcontractor has not been paid within seven (7) calendar days of SCDOT's payment to the Contractor or paid as provided in paragraph (1) for sub-tiers, the RCE will notify the Director of Construction. If SCDOT has not approved the delay in payment pursuant to paragraph 3 above, appropriate remedies set forth in paragraph (4) will be applied. On federally funded projects, the subcontractor may contact the Federal Highway Administration should SCDOT fail to address the non-payment issue.

(6) The Contractor agrees by submitting this bid or proposal that it will include this clause titled "PROMPT PAYMENT CLAUSE," provided by the SCDOT, without modification, in all subcontracts with its subcontractors. Contractor is responsible for requiring all of its subcontractors to include this PROMPT PAYMENT CLAUSE in all lower tier subcontracts. If Contractor knowingly enters or knowingly allows a subcontractor or lower tier subcontractor to enter into a subcontract without the PROMPT PAYMENT CLAUSE, SCDOT may apply the appropriate remedies set forth in paragraph (4) or pursue other available remedies, including breach of contract.

July 01, 2019

**Sloped Edge Longitudinal Shoulder Joints**

**Add the following to Subsection 401.4.23 of the Standard Specifications:**

All surface mixtures placed at 150 lbs. per square yard or greater will require the sloped edge joint device. The device contacts the surface of the shoulder of the road and creates an improved transition to cross roads, driveways and obstructions. The device may be removed if deemed necessary for projects that do not require or need a sloped edge profile.

Use a sloped edge longitudinal shoulder joint attachment for the asphalt paver in order to create a sloped edge profile onto an existing roadway shoulder. Construct a sloped edge onto the longitudinal shoulder joint to promote a safe transition between the newly placed asphalt mixture and the existing shoulder (without curb or other confined edges) using an approved device.

Approved devices are listed on Qualified Product Listing No. 75. These devices must meet the requirements of this specification and Qualified Product Policy No 75 to be included on QPL 75. The sloped edge device will be designed to be attached to the paver that confines the material at the end gate and extrudes the asphalt material in such a way that results in a consolidated wedge shape pavement edge of between 25-35 degrees. The device must be designed to constrain the asphalt material by reducing the area by 10 to 15% thereby increasing the consolidation of the extruded profile. The use of a conventional single plate strike off is not permitted.

**APPROVED:**  
**Division Administrator**

By: \_\_\_\_\_  
**FEDERAL HIGHWAY ADMINISTRATION**

July 1, 2010

**Subsection 401.4.17, Transportation and Delivery of Mixes, of the Standard Specification will be deleted in its entirety and replaced with the following:**

Transport the HMA from the plant to the point of use in vehicles meeting the requirements of Subsection 401.3.7. Do not permit any load of HMA to leave the plant so late in the day that it cannot be spread, finished, and compacted during daylight of that same day unless an approved artificial lighting system is provided. Ensure that HMA mixtures containing the asphalt binder grades below are produced and delivered to the jobsite within the acceptance range listed in the table below with exception that Base C and D mixtures will be produced and delivered at a temperature range of 240°-275° F. The mix temperatures will be checked using SC-T-84. Ensure the HMA mixtures are held within the acceptance range based on Binder Performance Grade in the Job Mix Formula. Deliver mixture within the acceptance range for temperature to assist in obtaining density requirements which provide smooth riding pavements with uniform texture.

<b>Binder Performance Grade</b>	<b>Acceptance Range (°F)</b>
PG 64-22	265°-325°
PG 70-22	285°-335°
PG 76-22	300°-350°

Note: This temperature specification does not apply to WMA (SC-M-408). Refer to the HMA Contractor's QC Plan for mix acceptance range based on selected asphalt plant WMA technologies.



**Supplemental Technical Specification for  
Cement Modified Recycled Base**

SCDOT Designation: SC-M-306 (07/21)

**APPROVED:**

**Division Administrator**

**THADDEUS  
W KITOWICZ**

Digitally signed by  
THADDEUS W KITOWICZ  
Date: 2021.06.10 10:49:32  
-04'00'

By: \_\_\_\_\_

**FEDERAL HIGHWAY ADMINISTRATION**

**1.0 DESCRIPTION**

- 1.1 This section contains specifications for the materials, equipment, construction, measurement, and payment for the modification of an existing paved roadway or shoulder by scarifying the existing pavement structure, mixing it with Portland cement, and constructing the base course in conformance with the lines, grades, dimensions, and cross-sections shown on the Plans or as directed by the **RCE**.

**2.0 MATERIALS**

- 2.1 Portland Cement - Use Portland cement that conforms to the requirements of **Subsection 301.2.1**.
- 2.2 Water - Use water conforming to the requirements of **Subsection 701.2.11**.
- 2.3 Asphalt Material – Use asphalt material conforming to the requirements of **Subsection 301.2.4**.

**3.0 EQUIPMENT**

- 3.1 Ensure that the equipment necessary for the proper construction of the work is on site and in acceptable working condition. Provide sufficient equipment to enable prosecution of the work in accordance with the project schedule and completion of the work in the specified time.
- 3.2 Construct the base with self-propelled rotary mixer(s)/reclaimer(s) capable of mixing in place to the required depth. The mixer(s)/reclaimer(s) shall have a mechanism for controlling the reclaimed material gradation via breaker bar and/or a door opening on the mixer(s)/reclaimer(s). Mixer(s)/reclaimer(s) shall be fitted with an integrated liquid injection system capable of introducing liquid into the cutting drum during the mixing process.
- 3.3 Provide a sufficient number of water trucks on the jobsite at all times of operation to maintain the moisture requirements listed in **Subsection 9**. Ensure that the water truck used in conjunction with the reclaimer uses a direct injection system, and additional trucks maintain surface moisture during grading and compaction work and until the curing treatment is applied in accordance with **Subsection 13**. Accomplish this using a controlled and uniform application of water without eroding or otherwise damaging the CMRB surface.
- 3.4 Provide a spreader/distributor capable of achieving consistent, accurate and uniform distribution across the entire length and width of the roadway while minimizing dust. Ensure that the spreader has adjustable openings or gate headers and is not solely dependent on vehicle speed to obtain the required spread rate.
- 3.5 Provide a combination of sheepsfoot rollers, smooth wheel tandem rollers, and/or pneumatic-tired rollers that have the ability to adequately compact reclaimed material throughout the entire specified CMRB thickness. Ensure the necessary weight, size and number of rollers to achieve the requirements of **Subsection 10**.

## 4.0 CONSTRUCTION

- 4.1 Regulate the sequence of work to process the necessary quantity of material to provide the full depth of modification as shown on the Plans:
  - 4.1.1 Ensure structural integrity of reclaimed material is consistent throughout the depth of the modification.
  - 4.1.2 Ensure surface quality is sufficient to provide durable temporary pavement structure surface and supports permanent pavement structure performance.
  - 4.1.3 Incorporate appropriate material as specified in the plans for drainage correction, cross slope correction or roadway strengthening.

## 5.0 QUALITY CONTROL PLAN, TEST STRIP & CORRECTIVE ACTION REQUIREMENTS

- 5.1 Prepare an annual Quality Control Plan that ensures that operational techniques and activities provide integral and finished material of acceptable quality for each Cement Modified Recycled Base project. Submit a Quality Control Plan for acceptance to the Chemical Stabilization Engineer (CSE) in writing a minimum of two weeks before work begins for the year.
- 5.2 The Quality Control Plan should include, but not be limited to addressing the following items;
  - 5.2.1 Contingency plans for pulverization, mixing and compaction when specifications criteria are not met. Consider the specific roadway conditions of various project sites.
  - 5.2.2 Plan for identifying in-situ moisture conditions, adjusting the moisture content to meet specifications, and maintaining moisture content through the time of curing. Include a description of the methods and minimum contractor testing for moisture. Consider specific environmental conditions of various project sites and schedules.
- 5.3 Test Strips
  - 5.3.1 The first load of cement on the roadway will be used as a test strip to determine if the contractor is capable of producing a mixture according to specifications. Particular attention will be paid to the moisture and compaction requirements set in **Subsection 10**, mixing and processing requirements set in **Subsection 9**, pulverization requirements set in **Subsection 7**, depth requirements in **Subsection 17**, and cement tolerances in **Subsection 8**. Cease production after the first load if any of the requirements of the specification are outside of the tolerances and change procedures to contingency plans approved in the QC Plan to continue work. Continue production as normal on the same day when the test strip meets the specification requirements.
  - 5.3.2 The first load applied with the contingency plans will be used as a test strip to evaluate the corrective action plan. Cease production after this initial load of cement if the requirements of this specification are still not being met and submit a revised corrective action plan to the **RCE** for acceptance prior to continuing work.
  - 5.3.3 If the requirements of this specification are not being met in a section not defined as a test strip (a section is defined as one load of cement) then one additional load of cement will be allowed. Cease production after this additional load of cement if the requirements are still not being met and submit a corrective action plan to the **RCE** for acceptance prior to continuing work.

## 6.0 SHOULDERS & ROADWAY PREPARATION

- 6.1 Remove all excess vegetation generated from the clipping and cleaning of shoulders from the roadway and any other debris, including Reflective Pavement Markers, prior to performing the mixing operations. Remove material from the shoulders as necessary to ensure proper drainage at all times.

## 7.0 PULVERIZATION

- 7.1 Provide means, methods, and equipment necessary to obtain satisfactory pulverization of the pavement so that at the completion of pulverization and mixing (prior to compactive efforts), a uniform mixture is created in which 100% of the reclaimed material mixture (by weight) passes a 3 inch sieve and 95% of the reclaimed material mixture (by weight) passes a 2 inch sieve. When necessary, SC-T-1 Section 6.6 will be used for sampling to run gradation tests. Rework areas not meeting this gradation control measure as necessary, adhering to the time limitations in **Subsection 11**. The pulverization pass is defined as at least one pass of the mixer prior to the application of cement. Additional passes are allowed. Lightly compact following each pass of the mixer to produce a uniform layer. Carefully control the depth of pulverization and conduct operations in a manner to ensure that the surface of the roadbed below the pulverized material remains undisturbed and conforms to the required cross-section. Means, methods and equipment including but not limited to additional passes of the reclaimer, milling in place or the use of supplementary equipment to achieve pulverization is the responsibility of the contractor and incidental to the process.
- 7.2 If the requirements of pulverization are not being met in a section not defined as a test strip (a section is defined as one load of cement) then one additional load of cement will be allowed. Cease production after this additional load of cement if the requirements are still not being met and submit a corrective action plan to the **RCE** for acceptance prior to continuing work.

## 8.0 APPLICATION OF CEMENT

- 8.1 The **CSE** will determine the rate of cement based on test results supplied in writing by the Contractor. Do not commence construction until an approved rate has been determined by the **CSE**. Allow two weeks from the date of submittal for the results and selection of appropriate cement rate. The test results will be conducted according to SC-T-26 by an AASHTO-accredited laboratory with material obtained from the roadway in which construction is to occur. Ensure that the roadway sampling and mix design testing is representative of the entire area and depth to be treated, several samples and/or designs may be necessary.
- 8.2 Spread Portland Cement uniformly on the pulverized material at the rate established by the **CSE**, taking care to minimize fugitive dust and minimize overlapping of the passes (maximum 6 inches). Apply cement only when the temperature is 40°F in the shade and rising, and no freezing temperatures are predicted for at least 48 hours. Do not perform work on frozen or excessively wet subgrade. A tolerance of 5% (of the rate) is allowed in the spread rate for individual sections (load of cement) of roadway; however, adjustments should be made in order to keep the actual spread rate as close to that established by the **CSE**. Only apply cement to such an area that all the operations (including final compaction) can be continuous and completed in daylight, unless adequate artificial light is provided. Ensure that all operations (including final compaction) can be completed within 3 hours of application of cement.

- 8.3 Do not allow the percentage of moisture in the reclaimed material mixture at the time of cement application to exceed the quantity that permits uniform and thorough mixture of reclaimed material or that creates instability of the roadway. Do not allow equipment, except that used in spreading and mixing, to pass over the freshly spread cement until it is mixed with the reclaimed material mixture.
- 8.4 If the requirements of cement application are not being met in a section not defined as a test strip (a section is defined as one load of cement) then one additional load of cement will be allowed. Cease production after this additional load of cement if the requirements are still not being met and submit a corrective action plan to the **RCE** for acceptance prior to continuing work.

## 9.0 MIXING & PROCESSING

- 9.1 Pulverize material as necessary to meet the requirements given in **Subsection 7**. The pulverization pass is defined as at least one pass of the mixer prior to the application of cement. Lightly compact following each pass of the mixer to produce a uniform layer.
- 9.2 After the cement has been applied per **Subsection 8**, mix and uniformly add necessary moisture to the reclaimed material to ensure that the moisture content is above the optimum value as set in the approved mix design and within +/- 2% of the optimum moisture content when tested within 30 minutes of final compaction. Mix with at least one pass of the reclaimer after cement application at minimum. Additional passes are allowed, adhering to time limitations set forth within this specification. Ensure full width pulverizing and mixing by overlapping a minimum of 6 inches with each longitudinal pass, including at the longitudinal joint of each lane, and a minimum of 2 feet with each transverse joint. Additional mixing passes may be required in the contract documents. Lightly compact following each pass of the mixer to produce a uniform layer.
- 9.3 Immediately begin final compaction after the mixing process has been completed so that the requirements of **Subsection 10** are met.
- 9.4 Remove excess material generated from the mixing process after final grading operations have been completed.
- 9.5 If the requirements of mixing and processing are not being met in a section not defined as a test strip (a section is defined as one load of cement) then one additional load of cement will be allowed. Cease production after this additional load of cement if the requirements are still not being met and submit a corrective action plan to the **RCE** for acceptance prior to continuing work.

## 10.0 COMPACTION

- 10.1 Before beginning compaction, ensure that the mixture is free from excessive fluff and overly compacted areas to allow for uniform compaction of the layer. Continue compaction until the entire depth of the base course mixture is uniformly compacted to not less than 95% of the maximum density. SC-T-23, SC-T-26, SC-T-27, or SC-T-29 will be used at the discretion of the **RCE** to determine the maximum density of the composite mix. If tests show that 95.0% requirement is not being met, adjust construction operations to obtain the required density. Complete the compaction work within 1 hour of the final mixing pass.
- 10.2 After the mixture is compacted, reshape the surface of the base course as necessary to conform to the required lines, grades, and cross-section. Perform light scarifying to a depth which removes the sheepfoot imprints at minimum. Continue as required to obtain a uniform surface and to prevent scaling and delamination.

- 10.3** Perform compacting and finishing in a manner that produces a smooth, closely knit surface, free from equipment imprints, cracks, ridges, or loose material. Maintain the moisture content of the mixture within +/- 2% of the optimum moisture as determined by the pre-approved mix design and keep the surface continuously moist to the time of final curing coat being applied. The moisture content and density requirements for compaction will be tested for acceptance within 30 minutes of final compaction. Additional moisture contents tests will be randomly performed for acceptance through the curing application to ensure that the surface moisture is maintained above optimum moisture.
- 10.4** If the requirements of compaction are not being met in a section not defined as a test strip (a section is defined as one load of cement) then one additional load of cement will be allowed. Cease production after this additional load of cement if the requirements are still not being met and submit a corrective action plan to the **RCE** for acceptance prior to continuing work.

## **11.0 CONSTRUCTION LIMITATIONS**

- 11.1** Perform work in daylight hours unless adequate artificial light is provided. Limit the area over which the cement-pavement mixture is spread so that all operations specified in **Subsections 7, 8, 9, 10 and 13** are performed continuously until completion of a section (load of cement). Complete all grading and compaction work on a section (load of cement) within 2 hours after the initial mixing pass of the reclaimer unless the **RCE** approves a longer period.
- 11.2** If operations are interrupted for a continuous period of greater than 1 hour after the cement has been mixed with the reclaimed material, reconstruct the entire affected section (area of interruption) in accordance with these specifications. When the uncompacted reclaimed material mixture and cement is wetted so that the moisture content exceeds that specified, manipulate and aerate the mixture to reduce the moisture to the specified content provided the base course is completed within the time limits of these specifications.
- 11.3** Begin subsequent lifts of asphalt or chip seals which cover the Cement Modified Recycled Base curing methods and act as a final riding surface within 7 calendar days of completion of the CMRB section unless the **RCE** approves a longer period. Begin these subsequent lifts so that no more than 4 miles have temporary surface treatment on them at any time. A section is defined as the contract section of roadway receiving CMRB treatment. When using Curing Methods B or C, ensure that a milled surface is not left open to the public for more than 72 hours.

## **12.0 WEATHER LIMITATIONS**

- 12.1** Apply cement only when the temperature is 40°F in the shade and rising, and no freezing temperatures are predicted for at least 48 hours. Do not perform work on frozen or excessively wet subgrade. The temperature restrictions for single treatment, when used as a curing option, shall meet the requirements of this reclamation specification. If the successive course is a final riding course, the seasonal restrictions of December, January and February apply unless otherwise approved by the DOC.

## **13.0 CURING**

- 13.1** After the Cement Modified Recycled Base has been finished as specified, cure the surface using the specified method in the plans or contract. Dampen and sweep the CMRB immediately prior to the application of the surface treatment.

*Curing Method A: Surface (Single) Treatment*

*Curing Method B: Surface (Single) Treatment with Milling*

*Curing Method C: Surface (Double) Treatment with Milling*

- 13.2** After the Cement Modified Recycled Base has been finished as specified, protect the base from rapid drying and traffic by placing Asphalt Surface Treatment as specified in **Section 406 or 407**, with the exception that lightweight aggregate is not required and CRS-2 may be used in place of CRS-2P. Perform this operation daily to protect the newly constructed Cement Modified Recycled Base, unless otherwise directed by the RCE.
- 13.3** Prior to placement of the HMA course in Methods B & C, mill the Cement Modified Recycled Base course surface to obtain a true and level finish for the asphalt placement. Ensure that a diamond milling pattern with a double or triple strike is clearly visible in the finished surface. Consider the final thickness during construction, leaving the specified depth of treatment after the milling has occurred. Ensure that the surface is left in a condition ready for paving, free from scabbing, scaling and other defects. Ensure that any structure lost to additional, deeper milling to remove these defects is replaced with asphalt. Include this cost in the Cement Modified Recycled Base price.

#### **14.0 CONSTRUCTION JOINTS**

- 14.1** At the end of each day's construction, form a straight construction joint as specified in **Subsection 301.4.9**.

#### **15.0 SURFACE SMOOTHNESS**

- 15.1** Ensure that the finished surface of the recycled base meets the requirements of **Subsection 301.4.10**. The grade of the road will be based on existing conditions of the roadway. Grade the cross slope to obtain positive drainage as well as smooth transitions from crown to superelevated sections of the roadway, re-grade roads with a pre-existing cross slope of 2% or greater to the same cross slope. On roads with a pre-existing cross slope of less than 2%, the Contractor and RCE will determine the measures required to obtain positive drainage and the final crossslope.

#### **16.0 RIDEABILITY**

- 16.1** Ensure that the final asphalt surface placed on Cement Modified Recycled Base course meets the Rideability requirements of SC-M-403 for either New Construction or Resurfacing, whichever is applicable based on the specified pavement structure.

#### **17.0 THICKNESS TOLERANCE**

- 17.1** The thickness of the completed Cement Modified Recycled Base will be measured at random intervals not to exceed 1,000 feet in length. The average job thickness will be measured daily using the average value of all measurements taken by the inspector each day. Where the measured thickness is more than 1 inch greater than the specified thickness, the thickness of that location will be considered the specified thickness plus 1 inch. If the average job thickness varies from the specified job thickness by more than ½ inch, an adjusted unit price is used for calculating payment. The pay factor will be calculated as below and applied;

$$\text{Pay Factor} = 1 - \frac{|\text{Average Job Thickness} - \text{Specified Job Thickness}|}{\text{Specified Job Thickness}}$$

$$\text{Adjusted Contract Unit Price} = \text{Pay Factor} * \text{Contract Unit Price}$$

**17.2** If the requirements of thickness (any single test value greater than 1 inch different from the specified depth) are not being met in a section not defined as a test strip (a section is defined as one load of cement) then one additional load of cement will be allowed. Cease production after this additional load of cement if the requirements are still not being met and submit a corrective action plan to the **RCE** for acceptance prior to continuing work.

## **18.0 OPENING TO TRAFFIC**

**18.1** Local traffic may use completed portions of the Cement Modified Recycled Base provided the base has hardened sufficiently to prevent marring, damaging or visible rutting of the surface by such usage. Ensure that no damage occurs to the curing coat. With approval of the District Office, temporary detours may be utilized during the reclamation process to reduce the traffic on the reclaimed roadway. Use the subgrade shoulders or completed pavement, when available, for transporting materials, workers, and equipment throughout the project. Do not place construction equipment on the base without the approval of the **RCE** unless it is being used in the subsequent construction operation.

## **19.0 MAINTENANCE**

**19.1** Maintain the Cement Modified Recycled Base in accordance with **Subsection 301.4.13**.

## **20.0 MEASUREMENT**

**20.1** The quantity for the pay item Cement Modified Recycled Base (of the uniform thickness required) is the surface area of a uniform base constructed by applying and mixing cement with the subgrade as specified and is measured by the square yard (SY) of the modified base in-place, complete and accepted. Cement Modified Recycled Base constructed outside the designated area is not measured for payment.

**20.2** The quantity for the pay item Portland Cement for Cement Modified Recycled Base is the weight of cement incorporated into the base at the rate established by the **CSE** and is measured by the ton (TON), complete and accepted. Portland cement incorporated in excess of 5% of the amount established by the **CSE** is not included in the measurement. Furnish the **RCE** with invoices of all cement received to verify weight.

## **21.0 PAYMENT**

**21.1** Payment for the accepted quantity of Cement Modified Recycled Base (of the uniform required thickness) or Portland Cement for Cement Modified Recycled Base, measured in accordance with **Subsection 20** is determined using the contract unit bid price for the applicable item.

**21.2** Payment for Cement Modified Recycled Base (of the uniform required thickness) is full compensation for constructing the Cement Modified Recycled Base course as specified or directed and includes pulverizing and scarifying the existing pavement,

applying and spreading cement, processing and mixing base course material, watering and maintaining proper moisture content, compacting, finishing, curing, hauling and disposing of excess shoulder material and curing base course, forming construction joints, and all other materials, labor, equipment, tools, transportation, and incidentals necessary to complete the work in accordance with the Plans, the Specifications, and other terms of the Contract.

- 21.3** Base course that is deficient in thickness is paid for at the adjusted unit price specified in **Subsection 20**.
- 21.4** Payment for Portland Cement for Cement Modified Recycled Base is full compensation for furnishing and weighing the cement as specified or directed and includes all other materials, labor, equipment, tools, supplies, transportation, and incidentals necessary to complete the work in accordance with the Plans, the Specifications, and other terms of the Contract.
- 21.5** Payment for excess reclaimed material generated from the roadway (excluding shoulder material) is paid for as unclassified excavation.
- 21.6** Payment for each item includes all direct and indirect costs or expenses required to complete the work.
- 21.7** Pay items under this section include the following:

<b>Item No.</b>	<b>Pay Item</b>	<b>Unit</b>
3063306	Cement Modified Recycled Base (6" Uniform)	SY
3063308	Cement Modified Recycled Base (8" Uniform)	SY
3063310	Cement Modified Recycled Base (10" Uniform)	SY
3063312	Cement Modified Recycled Base (12" Uniform)	SY
3064000	Portland Cement for Cement Modified Recycled Base	TON



APPROVED:  
Division Administrator

January 1, 2020

By: \_\_\_\_\_  
FEDERAL HIGHWAY ADMINISTRATION

**SECTION 810: EROSION CONTROL MEASURES**

In addition to the erosion control measures specified in the Plans, Standard Specifications, Supplemental Technical Specifications and the Special Provisions, the Contractor is advised that all land disturbing activities (clearing and grubbing, excavation, borrow and fill) are subject to the requirements set forth in the following permits and regulations:

- South Carolina Code of Regulations 63-380, Standard Plan for Erosion, Sediment, and Stormwater Runoff Control. The regulation can be found at the South Carolina Legislature website.
- Erosion and Sediment Reduction Act of 1983 (Title 48, Chapter 18 of the South Carolina Code of Laws of 1983, as amended). Section 70 of this code authorized the South Carolina Department of Health and Environmental Control (SCDHEC) to administer this regulation with respect to lands under the jurisdiction of the South Carolina Department of Transportation. The code can be found at the South Carolina Legislature website.
- National Pollutant Discharge Elimination System (NPDES) General Permit Number SCR160000, effective January 1, 2013 (or latest version): The Environmental Protection Agency, in accordance with the Federal Clean Water Act, has granted to the South Carolina Department of Health and Environmental Control (SCDHEC) the authority to administer the Federal NPDES permit program in the State of South Carolina. The permit may be viewed at the SCDOT website.

In accordance with the NPDES General Permit SCR160000 section 2.1.E: "The Prime Contractor hired by SCDOT for a project will become a Secondary Operator with SCDOT upon signing the awarded contract. The Secondary Operator must complete the agreement found in Appendix B of the SCDOT Contract, (Contractor Certification Form). The agreement is to be signed in accordance with the signatory requirements of §122.22 of the South Carolina Regulation 61-9. The agreement is to be maintained with the SWPPP.

By signing the Contract, the contractor accepts/understands the terms and conditions of the *Storm Water Pollution Prevention Plan (SWPPP)* as required by the NPDES General Permit SCR160000 and may be legally accountable to SCDHEC for compliance with the terms and conditions of the SWPPP. In addition the contractor is responsible for ensuring all subcontractors comply with the SWPPP and the permit requirements.

The SCDOT will complete and forward a *Notice of Intent (NOI)* to SCDHEC. If SCDHEC does not send a letter within 10 business days of receipt of the *NOI*, authorizing coverage, denying coverage, or advising that a review of the *SWPPP* will take place, coverage will be automatically granted.

At the pre-construction conference, with the contractor, the *SWPPP* will be explained and discussed so that the contractor is made aware of their responsibilities in the *SWPPP*.

Upon authorization of coverage, the *SWPPP* is to be fully implemented. The prompt installation of erosion control devices should be coordinated with construction activities to maintain compliance with the above regulations and NPDES General Permit.

---

SUPPLEMENTAL SPECIFICATION

---

Erosion and Sediment Control Inspections are to be conducted by a qualified individual (Certified Erosion Prevention and Sediment Control Inspectors (CEPSCI), P.E., or those as stated in the permit) by the Department at least every 7-calendar days. A representative of the Contractor is also encouraged to accompany the inspection. Correct deficiencies noted during these inspections within the assigned priority period. If deficiencies are not corrected within this timeframe, the RCE can stop all work (except erosion and sediment control measures) until the deficiencies are corrected.

Give special attention to critical areas within the project limits (i.e., running streams, water bodies, wetlands, etc.). In these areas, the RCE may direct the Contractor to undertake immediate corrective action, but in no case allow these deficiencies to remain unresolved more than 48 hours for a priority 1 deficiency or 7 days for a priority 2 deficiency. This is in accordance with their assigned priority as identified during the Erosion and Sediment Control Inspection.

Failure to adequately comply with the provisions as detailed above or any other required erosion control measures can result in stoppage of all contract operations (except erosion and sediment control measures) until corrective action has been taken. Additional sanctions may be invoked by the SCDHEC in accordance with their authority.

Fines assessed on the Department by SCDHEC as the result of the Contractor's non-compliance or violation of said permit provisions will be paid by the Department and will subsequently be deducted from any monies due or that may become due to the Contractor. In case no monies are due or available, the fines incurred will be charged against the Contractor's Surety.

SUPPLEMENTAL SPECIFICATION

July 1, 2020

WORK ZONE TRAFFIC CONTROL  
TRAINING REQUIREMENTS  
FOR  
CONTRACTORS / SUBCONTRACTORS

APPROVED:  
Division Administrator  
**THADDEUS** Digitally signed by  
THADDEUS W KITOWICZ  
By: **W KITOWICZ** Date: 2020.05.28 16:27:32  
FEDERAL HIGHWAY ADMINISTRATION

**1. Description:**

This specification details the work zone traffic control training requirements for employees and representatives of a contractor or subcontractor under contract to the South Carolina Department of Transportation (SCDOT) whose job duties include responsibilities relative to implementation and maintenance of the Transportation Management Plan (TMP). "Employees and representatives of a contractor or subcontractor" will henceforth be referred to as "employee" or "employees" and "contractor or subcontractor" will henceforth be referred to as "contractor".

The SCDOT requires the contractor to provide documentation to substantiate successful completion and attainment of a passing score of a prescribed training course conducted by an SCDOT approved provider by those employees whose job duties categorize them as "designated trainees" as defined hereinafter.

**2. Implementation:**

These requirements for work zone traffic control training for employees of those entities under contract to the SCDOT whose job duties include responsibilities relative to implementation and maintenance of a TMP shall become effective on all projects let to contract after September 1, 2013.

**3. Designated Trainees:**

An employee whose job duty responsibilities, as designated hereto, impact or involve any of or all of the components of a TMP must successfully complete an advanced work zone traffic control training program. These components include the primary component, the "Temporary Traffic Control" plan, and the secondary components, the "Transportation Operations" plan and the "Public Information" plan.

An employee whose job duties include any of the following responsibilities regarding the TMP shall successfully complete an advanced work zone traffic control training program conducted by an SCDOT approved work zone traffic control training provider:

- Supervision of the field installation of any or all components of the TMP
- Supervision of the maintenance of any or all components of the TMP
- Supervision of the removal of any or all components of the TMP
- Design and development of revisions to an existing TMP
- Design and development of a new or alternate TMP
- Any decision-making responsibilities regarding the TMP

Those employees whose job duties do not include responsibilities relative to the TMP as stated above are not required to attend an advanced work zone traffic control training program. However, it is recommended that all employees whose job duties place them on the job site within the highway rights-of-way within 30 feet or less of a travel lane open to traffic should attend a basic work zone traffic control training course.

Also, an employee whose job duties include "flagger" shall successfully complete a "Flagger Training" course. However, regarding an employee whose job duties includes "flagger" but does not involve any of the responsibilities listed above, successful completion of a "Flagger Training" course is the only mandatory work zone traffic control training course required for this employee; other work zone traffic control training courses are elective.

**4. Approved Work Zone Traffic Control Training Providers:**

## SUPPLEMENTAL SPECIFICATION

Approved work zone traffic control training providers conduct work zone traffic control training in compliance with the MUTCD and reference requirements specific to SCDOT. For a listing of the SCDOT approved work zone traffic control training providers and the approved courses, see the document entitled, "Approved Work Zone Traffic Control Training Guidelines Training Providers / Course For Contractors / Subcontractors" latest edition. This document may be found at the web address below.

<https://www.scdot.org/business/pdf/accessMgt/trafficEngineering/TrainingProvidersListing.pdf>

Work zone traffic control training conducted by affiliates of the SCDOT approved providers in other states will be considered acceptable provided the training is comparable to the employee's job duty responsibilities. For example:

The South Carolina Chapter of the National Safety Council is listed as an acceptable work zone traffic control training provider for the SCDOT. Comparable work zone traffic control training conducted in Texas by the Texas Chapter of the National Safety Council will also be considered acceptable. This scenario applies to each approved work zone traffic control provider who also conducts training outside of South Carolina.

Specific course material for work zone traffic control training courses designated as "Basic", "Advanced", "Supervisor" or "Flagger" and any additional training courses not specified here is determined by the work zone traffic control training course provider and has undergone review and received acceptance by SCDOT. Also, the passing score for each training course is determined by the work zone traffic control provider.

### **5. Training Requirements / Qualifications:**

Successful completion of an advanced work zone traffic control training program is defined as achieving a passing score in all courses, including any prerequisite courses, to attain a level considered "advanced", "supervisor" or any other relative term as designated by the provider to imply the trainee has an understanding of the course material inclusive of design, implementation and maintenance of work zone traffic control scenarios. Upon successful completion of the program, the trainee should also possess an understanding for determining the need for and developing and implementing adjustments as necessary when applying typical work zone traffic control applications to non-typical work site conditions and scenarios.

The employee whose job duty responsibilities mandate successful completion of an advanced work zone traffic control training program shall do so prior to performing any job duties with responsibilities relative to design and development of a TMP or revisions of an existing TMP or any decision-making responsibilities regarding the TMP or supervision of the field installation and maintenance of any and all components of the TMP.

Also, an employee whose job duties mandate successful completion of a "Flagger" training course shall do so prior to performing any job duties relative to flagging traffic.

Each employee who has successfully completed an approved advanced work zone traffic control training program or a "Flagger" training course shall attend and complete a refresher course relative to the employee's job duties on a 5-year incremental time frame.

### **6. Documentation:**

The contractor shall provide proof of successful completion of an acceptable advanced work zone traffic control training class by those employees whose job duty responsibilities mandate successful completion of approved work zone traffic control training to the Resident Engineer prior to the employee performing the job duties that incorporate responsibilities which necessitate approved work zone traffic control training. For proof of successful completion of an approved work zone traffic control training class, provide a copy of the certificate of training from the organization who conducted the training to the Resident Engineer. Failure to provide the required documentation as specified shall prevent SCDOT acceptance of the employee as properly trained and acceptable for conducting those job duties that necessitate the prescribed work zone traffic control training.

## SUPPLEMENTAL SPECIFICATION

The contractor shall provide proof of successful completion of an acceptable "Flagger Training" course by all employees whose job duties require them to be the "Flagger" within a flagging operation to the Resident Engineer prior to the employee performing any "Flagger" job duties.

The contractor shall provide proof of successful completion of an acceptable advanced work zone traffic control refresher course for those employees no later than 60 days beyond the 5 year anniversary date of the employee's certificate date of completion of a previous advanced work zone traffic control training program.

Documentation of proof of completion of a basic work zone traffic control training course by employees whose job duties require their presence on the job site within the highway rights-of-way but exclude any responsibilities relative to the TMP is not required.

---

SUPPLEMENTAL SPECIFICATION

---

January 1, 2018

**Removal of Existing Asphalt Pavement before Patching**

Delete Subsection 401.4.14 Removal of Existing Asphalt Pavement before Patching, of the Standard Specifications in its entirety and replace with the following:

The **RCE** will determine the limits of distressed pavement and will mark width and length of patches. **RCE / RME** will inspect the road and ensures that drainage is adequate and no additional work needs to be done to the ditches and shoulders to promote proper drainage. The **RCE** may elect to obtain random cores if needed to determine proper depth of distressed area to be patched. Construct patches with a minimum size of 6.5 feet x 6.5 feet with at least 25 feet between patches. Care should be taken to ensure that longitudinal joints do not end up in the wheel paths. In the event that considerable quantities of full depth patching (FDP) are encountered, the RCE will consult with the State Pavement Design Engineer to consider other rehabilitation methods.

Remove the pavement to the depth indicated in the Plans, ensuring that the face of the cut is straight and vertical, with the exception of tapers needed to get equipment in and out of the patched area. If unstable material is encountered, remove additional material as directed by the **RCE**. Backfill the volume of the material removed below the patch with material meeting the requirements of **Section 305**, Graded Aggregate Base, and thoroughly compact in layers not exceeding 4 inches with a vibratory compactor. Thoroughly tack the sides of the existing pavement before placing the asphalt patch material in the hole.

Place the patch material in relatively uniform layers not to exceed the number of lifts in the table below. Ensure that the patch material is selected from the table below. Compact each layer with a vibratory compactor and a pneumatic roller. Whenever practical, allow lifts to cool down prior to placing the next lift, especially when doing multiple patches in the same area. The 175° F requirement between lifts does not apply to FDP. Conduct the work so that patches are opened and filled each day, with the roadway being opened to traffic by the end of each days operation.. Ensure that the finished patch is smooth riding by using a straight edge. Temperature and calendar restrictions found in **Section 401.4.4** do not apply, however no FDP will be permitted if the area is wet or frozen prior to removing the old pavement.

<b>Full Depth Patching Materials</b>		
<b>Depth of FDP</b>	<b>Select mixture type below based on Depth of FDP</b>	
	<b>Alternate Mixture Options</b>	<b>Typical Mixture</b>
4" or Less	Surface Type B / C 2 Lifts	Intermediate C 2 Lifts
6"	Surface Type B / C 2 Lifts	Intermediate C 2 Lifts
8"	Intermediate B Special 2 lifts	Intermediate C 3 lifts
10"	Intermediate B Special 2 lifts	Intermediate C 3 lifts
12" or More	Consult with the State Pavement Design Engineer	

January 1, 2019

### Asphalt Binder and Additives

**Delete Subsection 401.2.1.1, Binder and Additives, General of the Standard Specification in its entirety and replace it with the following:**

#### **401.2.1.1 Performance Graded (PG) Binder**

Use PG 64-22 or PG 76-22 binder as required by the contract that conforms to all of the requirements of AASHTO M 320. Do not use any combination of "air blown" asphalt binders. Ensure that the asphalt binder supplier lists all types of modifiers and additives used in the production of their PG binders including source of Re-Refined Engine Oil Bottoms (REOB), polymers, ground tire rubber (GTR), polyphosphoric acid (PPA), silicone, and liquid anti-stripping agent (LASA) in their Quality Control Plans. Ensure that additives used for compaction aides or anti-strips such as silicones, WMA additives, and LASA products are listed on the Bill of Lading (BOL). Use PG asphalt binders and modifiers that are heat and storage stable. Thoroughly blend the composite materials at the asphalt terminal before being loaded into the transport vehicle. Asphalt terminals that either supply or produce PG binders must be able to store multiple tanker loads of PG and certify that their products meet AASHTO M 320 prior to transferring or shipping on the BOL and that all modifiers and additives are compatible. Ensure that all PG binders adhere to *SCDOT Qualified Products Policy No. 37-38*. Only use PG 64-22 and PG 76-22 binder from sources listed on the most recent edition of *SCDOT Qualified Product List 37*.

#### **401.2.1.1.1 Modified Performance Graded Binder**

When specified, use modified binder consisting of a neat binder modified with a polymer or other modifier producing a binder complying with the requirements of a PG 76-22 as specified in AASHTO M 320 with the addition of the Multiple Stress Creep Recovery (MSCR) test using AASHTO T 350. Ensure acceptable elastomeric polymer is used by using Non-recoverable Creep Compliance values plotted against Percent Recovery based on figure 1 found in AASHTO R92 using RTFO aged material. Ensure that the MSCR test is performed at 64°C using the Very Heavy Traffic "V" Grade requirement in AASHTO M 332. Use elastomer polymer or modifier consisting of a styrene-butadiene (SB), styrene-butadiene-styrene (SBS), styrene-butadiene-rubber (SBR), or ground tire rubber (GTR). Polyphosphoric Acid (PPA) may also be added to the binder, but must not exceed 0.5% by weight of the asphalt binder. Varying blends of SB, SBS, SBR, GTR (7% min.), and PPA (0.5% max.) may be used, at the discretion of the AME, provided the end product meets all specified requirements for the PG 76-22. Perform the storage stability separation test ASTM D7173 to ensure the asphalt binder is homogenous. Ensure that all storage tanks on the asphalt plant site are clearly marked to prevent cross contamination of different PG binders.

#### **401.2.1.1.1.1 Ground Tire Rubber (GTR) in Performance Graded Binder**

Ensure that the Ground Tire Rubber (GTR) is terminally (no exceptions) blended with the neat asphalt to create a homogenous and storage stable PG 76-22 that meets all criteria as stated in 401.2.1.1.1, with the exception of Solubility requirement (AASHTO T 44). Blending the GTR modified binder at the asphalt plant during asphalt mixture production will not be permitted. Use a 2.0mm gap setting when using the DSR in accordance to AASHTO T 315 and AASHTO T 350. GTR materials must be free from excessive moisture when received from the tire recycling facility and stored in a dry location at the terminal to prevent blending issues with the binder modification process. A letter of compliance from the tire recycling facility will be required by the AME and the asphalt terminal stating that the GTR blend will meet this specification. The GTR must be free of loose metal particles, other foreign contaminating materials, with exception of embedded metal particles in the rubber. Mineral powder may be added to reduce sticking and caking of the GTR particles. Stabilizing or compatibility additive(s) can be used to achieve better particle distribution. Any additives used for this purpose must not be detrimental to the performance of the asphalt binder or mixture performance and must be accepted by the AME in the supplier's QC plan. Ensure that the GTR supplier provides certificates of compliance with each shipment certifying that all requirements of this specification are complied with for each production lot number and the end product is homogenous and shows no signs of separation or coagulation. In the event that the terminal changes supply sources of GTR type of grind

**SUPPLEMENTAL SPECIFICATION**

(ambient or cryogenic), or particle size, the asphalt terminal must perform a complete binder analysis on their revised product, and also provide a split sample to the SCDOT to ensure specification compliance.

Provide all sources of GTR and grind type in the asphalt terminal's QC plan. SCDOT may obtain samples of the GTR particles, base binder, or the finished GTR modified asphalt binder to ensure specification compliance at any time.

<b>Physical Test</b>	<b>Test Procedure</b>	<b>Specification</b>
Sampling of the GTR	ASTM E105 ASTM E122	In accordance to random sampling procedures
GTR Supply	ASTM D5603	Ambient or Cryogenic Grind
Dosage of GTR	Per COA & Supplier's QC Plan	Minimum of 7.0% by weight of the PG 64-22 base asphalt binder
GTR Specific Gravity	ASTM D5603	1.06 – 1.20
GTR Particle Distribution	ASTM D5644	30 Mesh Maximum of 2.0% Retained
GTR Metal Content	ASTM D5603	Maximum 0.01%
GTR Fiber Content	ASTM D5603	Maximum 0.50%
GTR Moisture Content	ASTM D1509	Maximum 0.75%
Mineral Filler –Talcum Powder (Optional)	ASTM M17	Maximum of 4.0%
Stabilizing Additives (Optional)	-	Maximum of 4.5% by wt. of GTR

<b>Chemical Test</b>	<b>Test Procedure</b>	<b>Specification</b>
Acetone Extract	ASTM D297	Maximum 25.0%
Rubber Hydrocarbon Content		40.0 – 60.0 %
Ash Content		Maximum 8.0 %
Carbon Black Content		20.0 – 40.0 %
Natural Rubber		16.0 – 45.0 %

**401.2.1.1.1.2 Ground Tire Rubber in Open Graded Friction Course or SMA Mixtures**

Stabilizing fibers and fiber supply systems at the asphalt plant may not be necessary when the GTR binder is used as required by section 409.2.3 and 409.4.3 of the Standard Specifications or any other Supplemental Specification for OGFC or SMA. Perform the SC-T-90 drain-down procedure at 350°F when conducting the asphalt mix design, or otherwise directed by the AME. In the event that drain-down values are found to be excessive, then stabilizing fibers may be necessary as directed by the AME. No additional compensation will be paid for the fibers in the OGFC or SMA mixture.

**401.2.1.1.1.3 Asphalt Plant Storage Requirements When Using Ground Tire Rubber**

Use a dedicated storage tank for "terminal blended GTR asphalt binder" at the asphalt plant. This tank must be capable of providing continuous mixing, as well as recirculation of the GTR asphalt binder as needed. Ensure that this tank is heated and capable of maintaining the temperature of the homogeneous blend of asphalt binder and GTR at 300°F to 350°F. Ensure that GTR modified binders are not mixed with other modified PG 76-22 binder without permission of the AME.



# **PROPOSAL SECTION**

**BID TABULATION**  
**COLLETON COUNTY MIDDLE SCHOOL PAVING**  
1/7/2022

<u>PAY ITEM</u>	<u>DESCRIPTION</u>	<u>QUANTITY</u>	<u>UNIT</u>	<u>UNIT COST</u>	<u>TOTAL</u>
1031000	MOBILIZATION	1.00	LS		
1032010	BONDS AND INSURANCE	1.00	LS		
1050800	CONSTRUCTION STAKES, LINES & GRADES	1.00	EA		
1071000	TRAFFIC CONTROL	1.00	LS		
2025000	REMOVAL & DISPOSAL OF EXISTING ASPHALT PAVEMENT	7887.00	SY		
2027000	REMOVAL & DISPOSAL OF EXISTING CONCRETE	2.00	CY		
3050108	GRADED AGGREGATE BASE COURSE (6" UNIFORM)	7887.00	SY		
4011004	LIQUID ASPHALT BINDER PG64-22	35.49	TON		
4030320	HOT MIX ASPHALT SURFACE COURSE TYPE B (150 LB/SY)	591.53	TON		
6271010	4" WHITE SOLID LINES (PVT. EDGE LINES/PARKING STRIPE) THERMO.- 90 MIL.	3013.00	LF		
6041074	4" YELLOW SOLID LINES(PVT.EDGE LINES) THERMO-90 MIL.	1702.00	LF		
6262015	8"WHITE SOLID LINES-CROSSWALK&CHANNELIZATION-EPOXY PAINT	125.00	LF		
62710XX	4" BLUE SOLID LINES (PVT. EDGE/ ACCESSIBLE/PARKING STRIPE) THERMO.- 90 MIL.	619.00	LF		
6271025	24" WHITE SOLID LINES (STOP/DIAG LINES)-THERMO.-125 MIL.	36.00	LF		
6271030	WHITE SINGLE ARROWS (LT. STRGHT, RT) THERMO.-125 MIL.	10.00	EA		
6271050	HANDICAP SYMBOL - THERMOPLASTIC - 125 MIL.	5.00	EA		
8100101	"NO PARKING" - THERMOPLASTIC - 90 MIL.	3.00	EA		
8152007	PERMANENT GRASSING	0.50	AC		
8153000	SEDIMENT TUBES FOR DITCH CHECKS	20.00	LF		
8153XXX	SILT FENCE	500.00	LF		
9999991	TREE PROTECTION	1000.00	EA		
9999991	SPEED HUMP	3.00	EA		
9999992	REMOVAL / REPLACEMENT SIGNAGE	1.00	LS		
9999993	ASPHALT INSPECTION AND MATERIALS TESTING	1.00	LS		

**ALTERNATIVE 1**

3063308	CEMENT MODIFIED RECYCLED BASE (8" UNIFORM)	7,887.00	SY		
3064000	PORTLAND CEMENT FOR CEMENT MODIFIED RECYCLED BASE COURSE (50 LB/SY)	197.18	TON		

**TOTAL:** \$0.00

NOTE: Payment for the accepted quantity of HMA Surface Course of the type specified will be paid for at the contract unit price bid or the Monthly Fuel Price Index. No adjustment of the contract unit price will be made due to fluctuations in the Monthly Asphalt Price. Contractor to submit a schedule and proposed completion date with their bid.

**COLLETON COUNTY MIDDLE SCHOOL PAVING**

**PROPOSAL FORM**

**DATE:** \_\_\_\_\_

Gentlemen:

In compliance with your invitation for bids, the undersigned hereby proposes to furnish all labor, equipment and materials, and to perform all work for the project referred to herein as:

**COLLETON COUNTY MIDDLE SCHOOL PAVING**

in strict accordance with the Contract Documents and in consideration of the amounts shown on the bid schedule attached hereto and totaling:

\_\_\_\_\_  
\_\_\_\_\_, and \_\_\_\_\_/100 dollars ( \$ \_\_\_\_\_ )

The undersigned hereby agrees that, upon written acceptance of this bid, he/she will within 10 days of receipt of such notice execute a formal contract agreement with the Owner, and that he/she will provide the bond or guarantees required by the contract documents.

The undersigned hereby agrees that, if awarded the contract, he/she will commence the work within Ten (10) calendar days after the date of written notice to proceed, and that he/she will complete the work within Sixty (60) calendar days after the date of such notice.

The undersigned acknowledges receipt of the following addenda:

\_\_\_\_\_

Enclosed is a bid guarantee, consisting of \_\_\_\_\_  
in the amount of \_\_\_\_\_.

Respectfully submitted,

\_\_\_\_\_  
FIRM  
NAME

\_\_\_\_\_  
BUSINESS ADDRESS

BY: \_\_\_\_\_

TITLE: \_\_\_\_\_

**COLLETON COUNTY MIDDLE SCHOOL PAVING  
CERTIFICATION FORM**

**PROJECT: COLLETON COUNTY MIDDLE SCHOOL PAVING**

**Failure to perform the above selections and requirements or to execute the certification below will make the bid non-responsive and not eligible for award consideration.**

By submitting this bid, **I hereby acknowledge** that all requirements included in the hard copy proposal, addendums, amendments, plans, standard specifications, supplemental specifications, and special provisions are part of this bid proposal and contract.

In accordance with the provisions of S.C. Code ANN.§§ 39-3-10 *et. seq.*, 39-5-10 *et. seq.*, 15 U.S.C. §45; 23 C.F.R. §635.112(F); and 28U.S.C. §1746, that I am an officer of the proposer firm and, under penalty of perjury under the laws of the United States and South Carolina, declare, by my certification below, that the following is true and correct, and further, that this firm, association or corporation has not, either directly or indirectly, entered into any agreement, participated in any collusion, or otherwise taken any action in restraint of free competitive bidding in connection with the submission of a bid proposal on the above referenced project.

By checking this box , I certify that I have read, understand, accept, and acknowledge all of the above statements.

Executed on \_\_\_\_\_ 20 \_\_\_\_.

Signed: \_\_\_\_\_

(Officer/Proposer)

\_\_\_\_\_  
(Title)

\_\_\_\_\_  
(Company)

\_\_\_\_\_  
(Address)

SEAL

**COLLETON COUNTY MIDDLE SCHOOL PAVING**

**NOTICE OF AWARD**

SUBJECT: NOTICE OF AWARD  
PROJECT: COLLETON COUNTY MIDDLE SCHOOL PAVING

Gentlemen:

The Owner has considered the BID submitted by you for the above described WORK in response to its Advertisement for Bids and Information for Bidders.

You are hereby notified that your BID has been accepted for items in the amount of \_\_\_\_\_ Dollars (\$ \_\_\_\_\_)

You have agreed in your Proposal to execute the Agreement and furnish the required Contractor's Performance Bond and Payment Bond within Ten (10) calendar days from the date of this Notice to you.

If you fail to execute said Agreement and to furnish said Bonds within Ten (10) days from the date of this Notice, said OWNER will be entitled to consider all your rights arising out of the OWNER'S acceptance of your BID as abandoned and as a forfeiture of your Bid Bond. The OWNER will be entitled to such other rights as may be granted by law.

You are required to return an acknowledged copy of this NOTICE OF AWARD to the OWNER.

Dated this \_\_\_\_\_ day of \_\_\_\_\_, \_\_\_\_.

Sincerely,

Cranston Engineering Group, P.C.

Matt Randall, PE

**\*\*\*ACCEPTANCE OF NOTICE\*\*\***

Receipt of the above NOTICE OF AWARD is hereby acknowledged by \_\_\_\_\_

this the \_\_\_\_\_ day of \_\_\_\_\_, 20\_\_\_\_

BY: \_\_\_\_\_ TITLE: \_\_\_\_\_

## COLLETON COUNTY MIDDLE SCHOOL PAVING

### AGREEMENT

THIS AGREEMENT, made on the \_\_\_\_\_ of \_\_\_\_\_, 2021  
by and between COLLETON COUNTY SCHOOL DISTRICT, party of the first part, hereinafter  
called the OWNER, and \_\_\_\_\_,  
party of the second part, hereinafter called the CONTRACTOR.

WITNESSETH, that the Contractor and the Owner, for the considerations hereinafter  
named, agree as follows:

#### ARTICLE I - SCOPE OF THE WORK

The Contractor hereby agrees to furnish all of the materials and all of the equipment and  
labor necessary, and to perform all of the work shown on the plans described in the specifications for  
the project entitled:

#### **2022 COLLETON COUNTY MIDDLE SCHOOL PAVING**

and in accordance with the requirements and provisions of the Contract Documents as defined in the  
General and Special Conditions hereto attached which are hereby made a part of this agreement.

#### ARTICLE II - TIME OF COMPLETION -- LIQUIDATED DAMAGES

The work to be performed under this Contract shall be commenced within ten (10) calendar  
days after the date of written notice by the Owner to the Contractor to proceed. The work shall be  
completed within Sixty (60) calendar days after the date of such notice and with such extensions of  
time as are provided for in the General Conditions.

It is hereby understood and mutually agreed, by and between the Contractor and the Owner,  
that the date of beginning, rate of progress and the time for completion of the work to be done  
hereunder are ESSENTIAL CONDITIONS of this Contract. Contractor agrees that said work shall  
be prosecuted regularly, diligently, and uninterruptedly at such rate of progress as will ensure full  
completion thereof within the time specified. It is expressly understood and agreed by and between  
the Contractor and the Owner, that the time for the completion of the work described herein is a  
reasonable time for the completion of the same, taking into consideration the average climatic range  
and construction conditions prevailing in this locality.

It is further agreed that time is of the essence of each and every portion of this contract and of  
the specifications wherein a definite portion and certain length of time is fixed for the performance  
of any act whatsoever; and where under the contract an additional time is allowed for the completion  
of any work, the new time limit fixed by extension shall be the essence of the Contract.

## COLLETON COUNTY MIDDLE SCHOOL PAVING

### ARTICLE III - PAYMENT

#### A. THE CONTRACT SUM

The Owner shall pay to the Contractor for the performance of the Contract the amounts determined for the total number of each of the units of work in the attached schedule completed at the unit price stated. The number of units contained in this schedule is approximate only, and the final payment shall be made for the actual number of units that are incorporated in or made necessary by the work covered by the Contract.

#### B. PROGRESS PAYMENTS

On not later than the fifth day of every month, the Contractor shall submit to the Engineer an estimate covering the percentage of the total amount of the Contract which has been completed from the start of the job up to and including the last working day of the preceding month, together with such supporting evidence as may be required by the Owner or/and the Engineer. The estimate shall include only quantities in place and at the unit prices set forth in the bid schedule. Within ten (10) days of receiving each Application for Payment, the Engineer shall either indicate in writing a recommendation of payment and present the application to the Owner or return the Application to the Contractor indicating in writing necessary corrections. In the latter case, the Contractor shall make the corrections and resubmit the application.

Fifteen days after presentation of the Application for Payment to the Owner with the Engineer's recommendation, the Owner shall, after deducting previous payments made, pay to the Contractor 90% of the amount of the estimate on units accepted in place. The 10% retained percentage may be held by the Owner until the final completion and acceptance of all work under the Contract.

**COLLETON COUNTY MIDDLE SCHOOL PAVING**

**ARTICLE IV - ACCEPTANCE AND FINAL PAYMENT**

- A. Upon receipt of written notice that the work is ready for final inspection and acceptance, the Engineer shall within 10 days make such inspection, and when he finds the work acceptable under the Contract and the Contract fully performed he will promptly issue a final certificate, over his own signature, stating that the work required by the Contract has been completed and is accepted by him under the terms and conditions thereof, and the entire balance found to be due the Contractor, including the retained percentage, shall be paid to the Contractor by the Owner within 20 days after the date of said final certificate.
  
- B. Before final payment is due the Contractor shall submit evidence satisfactory to the Engineer that all payrolls, material bills, and other indebtedness connected with the work have been paid, except that in case of disputed indebtedness or liens the Contractor may submit in lieu of evidence of payment a surety bond satisfactory to the Owner guaranteeing payment of all such disputed amounts when adjudicated in cases where such payment has not already been guaranteed by surety bond.
  
- C. The making and acceptance of the final payment shall constitute a waiver of all claims by the Owner other than those arising from unsettled liens, from faulty work appearing within 12 months after final payment, from requirements of the specifications, or from manufacturers' guarantees. It shall also constitute a waiver of all claims by the Contractor except those previously made and still unsettled.

IN WITNESS WHEREOF the parties hereto have executed this Agreement, the day and year first written above.

WITNESS:

**COLLETON COUNTY SCHOOL DISTRICT  
OWNER**

\_\_\_\_\_

BY: \_\_\_\_\_  
AS ITS MANAGER

WITNESS:

**CONTRACTOR**

\_\_\_\_\_

BY: \_\_\_\_\_  
TITLE



**COLLETON COUNTY MIDDLE SCHOOL PAVING**

**PERFORMANCE BOND**

(NOTE: THIS BOND IS ISSUED SIMULTANEOUSLY WITH PAYMENT BOND ON PAGE 133, IN FAVOR OF THE OWNER CONDITIONED FOR THE PAYMENT OF LABOR AND MATERIAL.)

KNOW ALL MEN BY THESE PRESENTS:

That \_\_\_\_\_ as Principal, hereinafter called Contractor, and a corporation organized and existing under the laws of the State of \_\_\_\_\_, with its principal office in the City of \_\_\_\_\_, State of \_\_\_\_\_, as Surety, hereinafter called Surety, are held and firmly bound unto COLLETON COUNTY SCHOOL DISTRICT, as Obligee, hereinafter called the Owner, in the penal amount of \_\_\_\_\_ Dollars (\$ \_\_\_\_\_) for the payment whereof Contractor and Surety bind themselves, their heirs, executors, administrators, successors, and assigns, jointly and severally, firmly by these presents for the faithful performance of a certain written agreement.

WHEREAS, Contractor has by said written agreement dated \_\_\_\_\_ entered into a contract with Owner for the construction of **COLLETON COUNTY MIDDLE SCHOOL PAVING** in accordance with the drawings and specifications which contract is by reference made a part hereof and is hereinafter referred to as the CONTRACT.

NOW, THEREFORE, the condition of this obligation is such that, if Contractor shall promptly and faithfully perform said CONTRACT, then this obligation shall be null and void; otherwise, it shall remain in full force and effect.

The Surety hereby waives notice of any alteration or extension of time made by the Owner.

Whenever Contractor shall be, and declared by Owner to be in default under the CONTRACT, the Owner having performed Owner's obligations thereunder, the Surety may promptly remedy the default, or shall promptly

1. Complete the CONTRACT in accordance with its terms and conditions, or
2. Obtain a bid or bids for completing the Contract in accordance with its terms and conditions, and upon determination by Surety of the lowest responsible bidder, or, if the Owner elects, upon determination by the Owner and the Surety jointly of the lowest responsible bidder, arrange for a contract between such bidder and Owner,

**COLLETON COUNTY MIDDLE SCHOOL PAVING**

and make available as Work progresses (even though there should be a default or a succession of defaults under the contract or contracts of completion arranged under this paragraph) sufficient funds to pay the cost of completion less the balance of the contract price; but not exceeding, including other costs and damages for which the Surety may be liable hereunder, the amount set forth in the first paragraph hereof. The term "balance of the contract price," as used in this paragraph, shall mean the total amount payable by Owner to Contractor under the Contract and any amendments thereto, less the amount properly paid by Owner to Contractor.

Any suit under this bond must be instituted before the expiration of one (1) year from the date on which final payment under the CONTRACT falls due.

No right of action shall accrue on this bond to or for the use of any person or corporation other than the Owner named herein or the heirs, executors, administrators or successors of the Owner.

Signed and sealed this \_\_\_\_\_ day of \_\_\_\_\_ A.D. 20 \_\_\_\_.

Witness \_\_\_\_\_ (Seal)  
\_\_\_\_\_ (Contractor)

Attest \_\_\_\_\_ By \_\_\_\_\_ (Seal)  
\_\_\_\_\_ (Title)

Witness \_\_\_\_\_ (Seal)  
\_\_\_\_\_ (Surety)

Attest \_\_\_\_\_ By \_\_\_\_\_ (Seal)  
\_\_\_\_\_ (Title)

**COLLETON COUNTY MIDDLE SCHOOL PAVING  
LABOR AND MATERIAL PAYMENT BOND**

(NOTE: THIS BOND IS ISSUED SIMULTANEOUSLY WITH PERFORMANCE BOND ON PAGE 131, IN FAVOR OF THE OWNER CONDITIONED FOR THE PERFORMANCE OF THE WORK.)

KNOW ALL MEN BY THESE PRESENTS:

That \_\_\_\_\_ as Principal, hereinafter called Contractor,  
and \_\_\_\_\_ a corporation organized and  
existing under the laws of the State of \_\_\_\_\_, with its principal office in the City of  
\_\_\_\_\_, State of \_\_\_\_\_, as Surety, hereinafter called Surety,  
are held, and firmly bound unto COLLETON COUNTY SCHOOL DISTRICT, as  
Obligee, hereinafter called the Owner, for the use and benefit of claimants as herein below defined  
in the amount of \_\_\_\_\_, Dollars (\$ \_\_\_\_\_)  
for the payment whereof Contractor and Surety bind themselves, their heirs, executors,  
administrators, successors, and assigns, jointly and severally, firmly by these presents.

WHEREAS, Contractor has by written agreement dated \_\_\_\_\_ entered into  
a contract with Owner for the construction of **COLLETON COUNTY MIDDLE SCHOOL  
PAVING**, in accordance with drawings and specifications which contract is by reference made a  
part hereof and is hereinafter referred to as the CONTRACT.

NOW, THEREFORE, the condition of this obligation is such that, if the Contractor shall  
promptly make payment to all claimants as hereinafter defined, for all labor and material used or  
reasonably required to use in the performance of the CONTRACT, then this obligation shall be  
void; otherwise, it shall remain in full force and effect, subject, however, to the following  
conditions:

1. A claimant is defined as one having a direct contract with the Contractor or with a subcontractor of the Contractor for labor, material, or both, used or reasonably required for use in the performance of the contract, labor and material being construed as to include that part of water, gas, power, light, heat, oil, gasoline, telephone service or rental of equipment directly applicable to the CONTRACT.
2. The above named Contractor and Surety hereby jointly and severally agree with the Owner that every claimant as herein defined, who has not been paid in full before the expiration of a period of Sixty (60) days after the date on which the last of such

## COLLETON COUNTY MIDDLE SCHOOL PAVING

claimant's work or labor was done or performed, or materials were furnished by such claimant, may sue on this bond for the use of such claimant, prosecute the suit to final judgment for such sum or sums as may be justly due claimant, and have execution thereon. The Owner shall not be liable for the payment of any costs or expenses of any such suit.

3. No suit or action shall be commenced hereunder by any claimant,
  - a) Unless claimant, other than one having a direct contract with the Contractor, shall have given written notice to any two of the following: The Contractor, the Owner, or the Surety above named, within Sixty (60) days after such claimant did or performed the last of the work or labor, or furnished the last of the materials for which said claim is made, stating with substantial accuracy the amount claimed and the name of the party to whom the materials were furnished, or for whom the work or labor was done or performed. Such notice shall be served by mailing the same by registered mail or certified mail, postage prepaid, in an envelope addressed to the Contractor, Owner or Surety, at any place where an office regularly maintained for the transaction of business or served in any manner in which legal process may be served in the state in which the aforesaid project is located, save that such service need not be made by a public officer.
  - b) After the expiration of one (1) year following the date on which Contractor ceased work on said CONTRACT, it being understood, however, that if any limitation embodied in this bond is prohibited by any law controlling the construction hereof, such limitation shall be deemed to be amended so as to be equal to the minimum period of limitation permitted by such law.
  - c) Other than in a state court of competent jurisdiction in and for the county or other political subdivision of the state in which the project, or any part thereof, is situated, or in the United States District Court for the district in which the project, or any part thereof, is situated, and not elsewhere.
4. The amount of this bond shall be reduced by and to the extent of any payment or payments made in good faith hereunder, inclusive of the payment by Surety of mechanics' liens which may be filed of record against said improvement, whether or not claim for the amount of such lien be presented under and against this bond.

**COLLETON COUNTY MIDDLE SCHOOL PAVING**

Signed and sealed this \_\_\_\_\_ day of \_\_\_\_\_ A.D. 20\_\_.

Witness \_\_\_\_\_ (Seal)  
\_\_\_\_\_ (Contractor)

Attest \_\_\_\_\_ By \_\_\_\_\_ (Seal)  
\_\_\_\_\_ (Title)

Witness \_\_\_\_\_ (Seal)  
\_\_\_\_\_ (Surety)

Attest \_\_\_\_\_ By \_\_\_\_\_ (Seal)

**COLLETON COUNTY MIDDLE SCHOOL PAVING**

**COLLETON COUNTY**  
**MIDDLE SCHOOL PAVING**

DATE \_\_\_\_\_

Address \_\_\_\_\_

\_\_\_\_\_  
\_\_\_\_\_

SUBJECT: NOTICE TO PROCEED  
PROJECT: **COLLETON COUNTY MIDDLE SCHOOL PAVING**

Gentlemen:

You are hereby notified to commence work in accordance with the Agreement, within Ten (10) calendar days following the date first written above, and you are to complete the work between April 14 and April 25, 2022 after the issued Notice to Proceed and the work at Thunderbolt Career and Technology Center is completed.

Sincerely,

Kenny Blakeney  
Director of Building and Grounds  
Colleton County School District

\*\*\*ACCEPTANCE OF NOTICE\*\*\*

Receipt of the above NOTICE TO PROCEED is hereby  
acknowledged by \_\_\_\_\_

this the \_\_\_\_\_ day of \_\_\_\_\_, 20\_\_.

BY: \_\_\_\_\_

TITLE: \_\_\_\_\_

\_\_\_\_\_

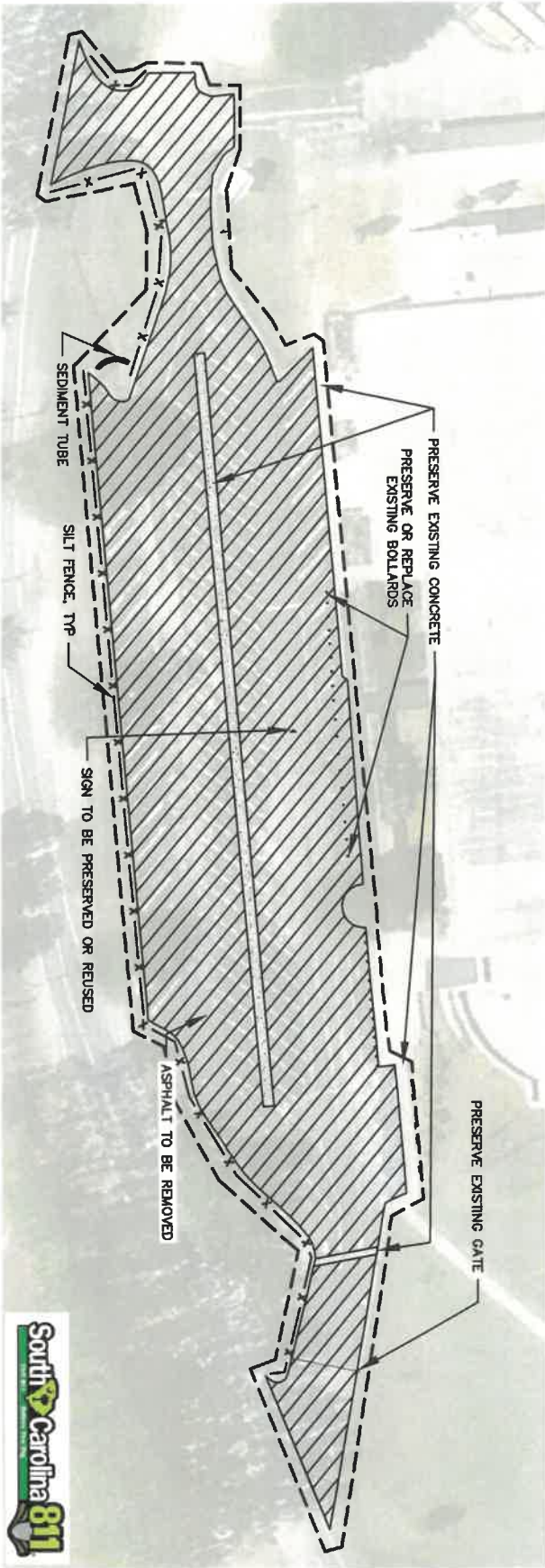
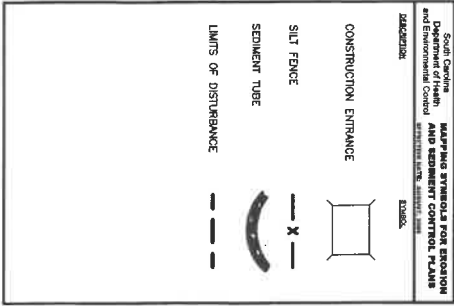

**GENERAL NOTES:**

1. RESURFACING BEGINS AT THE EDGE OF THE INTERSECTING ROAD.
  2. REFERENCE DESCRIPTION OF WORK AND TYPICAL SECTIONS FOR CONSTRUCTION LIMITS ON EACH ROAD.
  3. MATCH EXISTING ROADWAY MARKINGS.
  4. PRESERVE EXISTING CONCRETE.
  5. MATCH EXISTING EDGE OF PAVEMENT GRADES.
  6. SLOPE TO ENSURE POSITIVE DRAINAGE.
- DEMOLITION NOTES:**
1. THE CONTRACTOR SHALL CALL IN LOCATES OF UNDERGROUND UTILITIES PRIOR TO BEGINNING CONSTRUCTION.
  2. PRIOR TO BEGINNING CONSTRUCTION, THE CONTRACTOR SHALL INSTALL PERIMETER SILT FENCE AND INLET PROTECTION IN ACCORDANCE WITH THE EROSION, SEDIMENTATION & POLLUTION CONTROL PLAN.
  3. THE CONTRACTOR SHALL PROVIDE DUST CONTROL MEASURES FOR ALL DEMOLISHED AREAS BY WATER TRUCK OR OTHER SUFFICIENT MEASURES.
  4. ALL MATERIALS GENERATED FROM DEMOLITION OF THE EXISTING SITE FEATURES SHALL BE DISPOSED OF OFF-SITE IN ACCORDANCE WITH ALL STATE & LOCAL GUIDELINES.
  5. NO MATERIALS SHALL BE BURIED ON SITE.
  6. THE CONTRACTOR SHALL CONTACT ANY UTILITY PROVIDER WHOSE SERVICE MAY BE AFFECTED BY THE PROPOSED WORK PRIOR TO WORK ON THESE UTILITIES.
  7. NO WORK SHALL BE COMPLETED IN SOUTH CAROLINA DEPARTMENT OF TRANSPORTATION RIGHT-OF-WAY WITHOUT AN ENCROACHMENT PERMIT.
  8. ALL NEWLY GRADED AREAS THAT HAVE BEEN BROUGHT TO FINAL GRADE SHALL BE STABILIZED USING TEMPORARY SEEDING WITHIN 14 DAYS OF THE END OF DISTURBANCE.
  9. ALL BMP'S SHALL BE INSPECTED DAILY AND REPAIRED AS NECESSARY.
  10. THE CONCRETE WASHDOWN SHALL BE INSTALLED PRIOR TO COMMENCEMENT OF PAVING OPERATIONS.
  11. ANY AREAS OF EROSION THAT OCCUR PRIOR TO FINAL STABILIZATION SHALL BE REPAIRED BY THE CONTRACTOR.
  12. THE CONTRACTOR SHALL ENSURE FINAL STABILIZATION BY SEEDING ALL DISTURBED AREAS BY PERMANENT GRASSES AND PLANTING IN ACCORDANCE WITH THE APPROVED LANDSCAPE PLAN.
  13. ONCE GRASSING HAS A 70% DENSITY OF THE ENTIRE COVERAGE AREA, THE EROSION CONTROL BMP'S CAN BE REMOVED.
  14. THE ONLY STORM WATER POLLUTANT ANTICIPATED DURING CONSTRUCTION IS SEDIMENT. THE BMP'S INCLUDED ON THIS PLAN ARE DESIGNED TO REDUCE THE SEDIMENT.

**SOUTH CAROLINA**  
 PROFESSIONAL ENGINEER  
 MATTHEW E. R. [Signature]  
 NO. 24749

**SOUTH CAROLINA**  
 PROFESSIONAL ARCHITECT  
 CRANSTON ENGINEERING GROUP  
 NO. C00575

COLLETON COUNTY MIDDLE SCHOOL PARKING LOT PAVING	
DEMOLITION AND SWPP PLAN	
JOB NO. 2021-0318	DATE 1/10/2022
DRAWN PAG	CHECKED MER
APPROVED MER	

**CRANSTON**  
 ENGINEERING

01  
 SHEET

SEDIMENT TUBE INSTALLATION

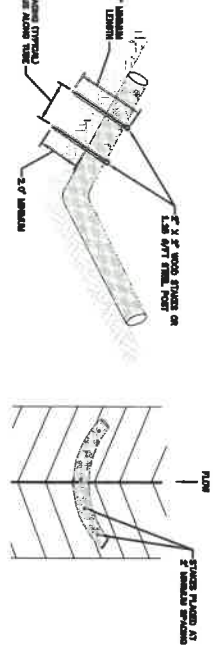

SEDIMENT TUBE SPACING

SLOPE	MAX. SEDIMENT TUBE SPACING
LESS THAN 2%	150 FEET
2%	100 FEET
3%	75 FEET
4%	50 FEET
5%	40 FEET
6%	30 FEET
GREATER THAN 6%	25 FEET

SOUTH CAROLINA DEPARTMENT OF PUBLIC HEALTH  
STANDARD DRAWING NO. SD-20 (PAGE 2)  
N13

SEDIMENT TUBES - INSPECTION & MAINTENANCE

1. SEDIMENT TUBES SHALL BE INSTALLED ALONG CONTIGUOUS LINE AND SHALL BE INSTALLED AT THE DOWN-SLOPE END OF EACH STRIP.
2. TUBES SHALL BE INSTALLED AT THE DOWN-SLOPE END OF EACH STRIP.
3. THE TUBES SHALL BE INSTALLED AT THE DOWN-SLOPE END OF EACH STRIP.
4. TUBES SHALL BE INSTALLED AT THE DOWN-SLOPE END OF EACH STRIP.
5. TUBES SHALL BE INSTALLED AT THE DOWN-SLOPE END OF EACH STRIP.
6. TUBES SHALL BE INSTALLED AT THE DOWN-SLOPE END OF EACH STRIP.
7. TUBES SHALL BE INSTALLED AT THE DOWN-SLOPE END OF EACH STRIP.
8. TUBES SHALL BE INSTALLED AT THE DOWN-SLOPE END OF EACH STRIP.
9. TUBES SHALL BE INSTALLED AT THE DOWN-SLOPE END OF EACH STRIP.
10. TUBES SHALL BE INSTALLED AT THE DOWN-SLOPE END OF EACH STRIP.
11. TUBES SHALL BE INSTALLED AT THE DOWN-SLOPE END OF EACH STRIP.
12. TUBES SHALL BE INSTALLED AT THE DOWN-SLOPE END OF EACH STRIP.
13. TUBES SHALL BE INSTALLED AT THE DOWN-SLOPE END OF EACH STRIP.
14. TUBES SHALL BE INSTALLED AT THE DOWN-SLOPE END OF EACH STRIP.
15. TUBES SHALL BE INSTALLED AT THE DOWN-SLOPE END OF EACH STRIP.

SOUTH CAROLINA DEPARTMENT OF PUBLIC HEALTH  
STANDARD DRAWING NO. SD-20 (PAGE 2)  
N13

SILT FENCE INSTALLATION

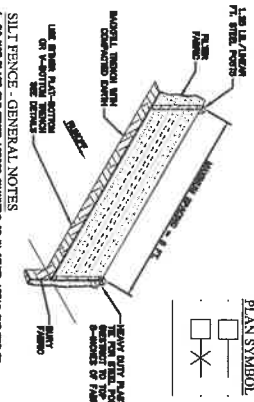

SILT FENCE - POST REQUIREMENTS

POST TYPE	MAX. SPACING
LESS THAN 2%	150 FEET
2%	100 FEET
3%	75 FEET
4%	50 FEET
5%	40 FEET
6%	30 FEET
GREATER THAN 6%	25 FEET

SOUTH CAROLINA DEPARTMENT OF PUBLIC HEALTH  
STANDARD DRAWING NO. SD-20 (PAGE 2)  
N13

SILT FENCE - INSPECTION AND MAINTENANCE

1. SEDIMENT TUBES SHALL BE INSTALLED ALONG CONTIGUOUS LINE AND SHALL BE INSTALLED AT THE DOWN-SLOPE END OF EACH STRIP.
2. TUBES SHALL BE INSTALLED AT THE DOWN-SLOPE END OF EACH STRIP.
3. THE TUBES SHALL BE INSTALLED AT THE DOWN-SLOPE END OF EACH STRIP.
4. TUBES SHALL BE INSTALLED AT THE DOWN-SLOPE END OF EACH STRIP.
5. TUBES SHALL BE INSTALLED AT THE DOWN-SLOPE END OF EACH STRIP.
6. TUBES SHALL BE INSTALLED AT THE DOWN-SLOPE END OF EACH STRIP.
7. TUBES SHALL BE INSTALLED AT THE DOWN-SLOPE END OF EACH STRIP.
8. TUBES SHALL BE INSTALLED AT THE DOWN-SLOPE END OF EACH STRIP.
9. TUBES SHALL BE INSTALLED AT THE DOWN-SLOPE END OF EACH STRIP.
10. TUBES SHALL BE INSTALLED AT THE DOWN-SLOPE END OF EACH STRIP.
11. TUBES SHALL BE INSTALLED AT THE DOWN-SLOPE END OF EACH STRIP.
12. TUBES SHALL BE INSTALLED AT THE DOWN-SLOPE END OF EACH STRIP.
13. TUBES SHALL BE INSTALLED AT THE DOWN-SLOPE END OF EACH STRIP.
14. TUBES SHALL BE INSTALLED AT THE DOWN-SLOPE END OF EACH STRIP.
15. TUBES SHALL BE INSTALLED AT THE DOWN-SLOPE END OF EACH STRIP.

SOUTH CAROLINA DEPARTMENT OF PUBLIC HEALTH  
STANDARD DRAWING NO. SD-20 (PAGE 2)  
N13

FLAT-BOTTOM TRENCH DETAIL

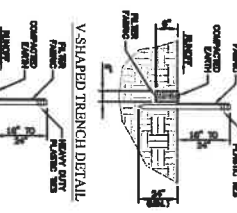

V-SHAPED TRENCH DETAIL

TRENCH TYPE	MAX. SPACING
LESS THAN 2%	150 FEET
2%	100 FEET
3%	75 FEET
4%	50 FEET
5%	40 FEET
6%	30 FEET
GREATER THAN 6%	25 FEET

SOUTH CAROLINA DEPARTMENT OF PUBLIC HEALTH  
STANDARD DRAWING NO. SD-20 (PAGE 2)  
N13

SILT FENCE - INSPECTION AND MAINTENANCE

1. SEDIMENT TUBES SHALL BE INSTALLED ALONG CONTIGUOUS LINE AND SHALL BE INSTALLED AT THE DOWN-SLOPE END OF EACH STRIP.
2. TUBES SHALL BE INSTALLED AT THE DOWN-SLOPE END OF EACH STRIP.
3. THE TUBES SHALL BE INSTALLED AT THE DOWN-SLOPE END OF EACH STRIP.
4. TUBES SHALL BE INSTALLED AT THE DOWN-SLOPE END OF EACH STRIP.
5. TUBES SHALL BE INSTALLED AT THE DOWN-SLOPE END OF EACH STRIP.
6. TUBES SHALL BE INSTALLED AT THE DOWN-SLOPE END OF EACH STRIP.
7. TUBES SHALL BE INSTALLED AT THE DOWN-SLOPE END OF EACH STRIP.
8. TUBES SHALL BE INSTALLED AT THE DOWN-SLOPE END OF EACH STRIP.
9. TUBES SHALL BE INSTALLED AT THE DOWN-SLOPE END OF EACH STRIP.
10. TUBES SHALL BE INSTALLED AT THE DOWN-SLOPE END OF EACH STRIP.
11. TUBES SHALL BE INSTALLED AT THE DOWN-SLOPE END OF EACH STRIP.
12. TUBES SHALL BE INSTALLED AT THE DOWN-SLOPE END OF EACH STRIP.
13. TUBES SHALL BE INSTALLED AT THE DOWN-SLOPE END OF EACH STRIP.
14. TUBES SHALL BE INSTALLED AT THE DOWN-SLOPE END OF EACH STRIP.
15. TUBES SHALL BE INSTALLED AT THE DOWN-SLOPE END OF EACH STRIP.

SOUTH CAROLINA DEPARTMENT OF PUBLIC HEALTH  
STANDARD DRAWING NO. SD-20 (PAGE 2)  
N13



**CRANSTON**  
ENGINEERING

COLLETON COUNTY MIDDLE SCHOOL PARKING LOT PAVING

DEMOLITION AND SWPPP DETAILS

JOB NO.	DATE	DRAWN	CHECKED	APPROVED
2021-0318	1/10/2022	PAG	MER	MER

SHEET  
02



- GENERAL NOTES:**
1. RESURFACING BEGINS AT THE EDGE OF THE INTERSECTING ROAD.
  2. REFERENCE DESCRIPTION OF WORK AND TYPICAL SECTIONS FOR CONSTRUCTION LIMITS ON EACH ROAD.
  3. MATCH EXISTING ROADWAY MARKINGS.
  4. PRESERVE EXISTING CONCRETE.
  5. MATCH EXISTING EDGE OF PAVEMENT GRADES.
  6. SLOPE TO ENSURE POSITIVE DRAINAGE.

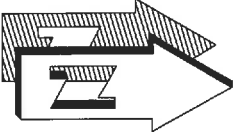
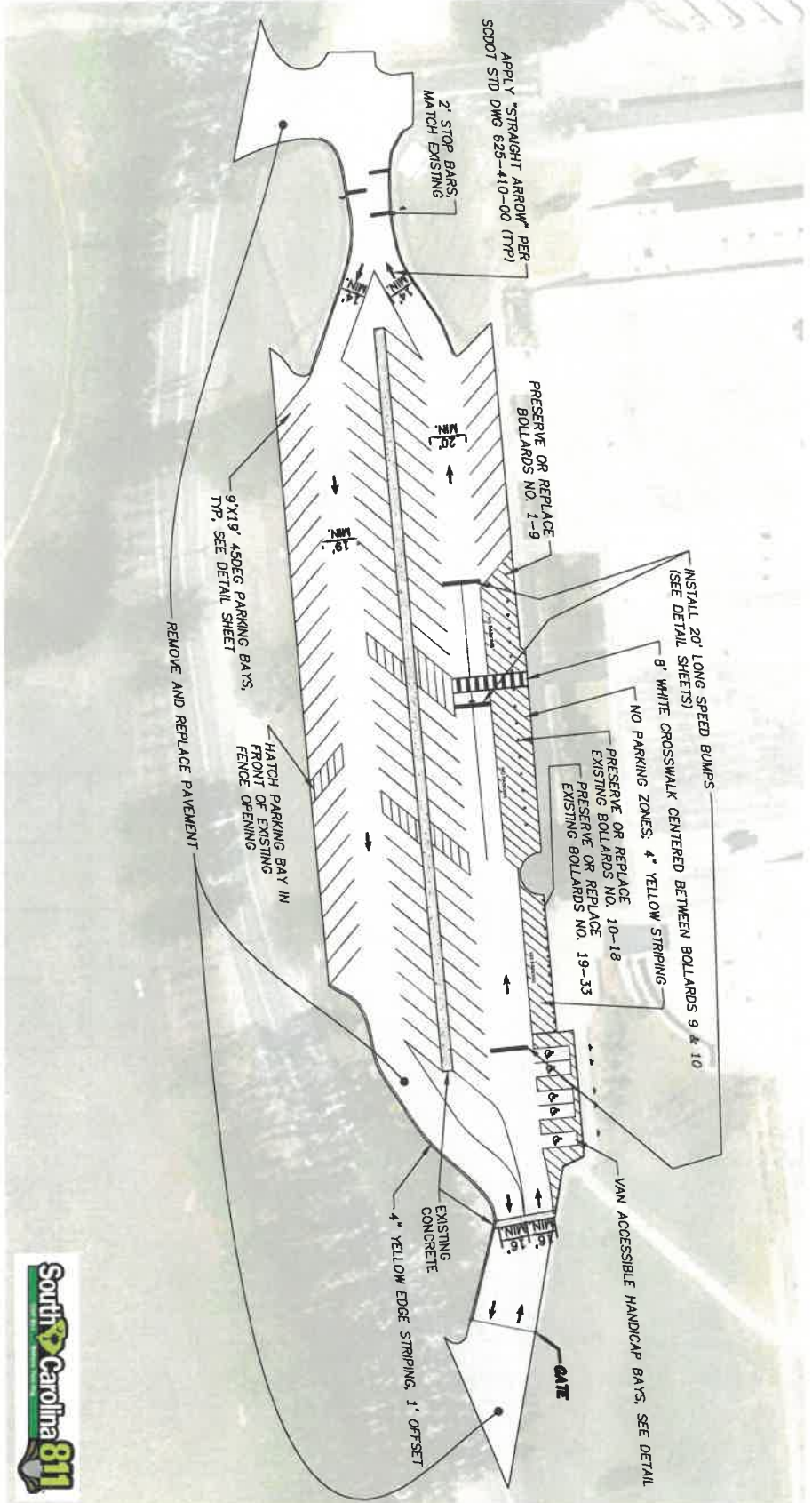

COLLETON COUNTY MIDDLE SCHOOL PARKING LOT PAVING

IMPROVEMENT AND PAVEMENT MARKING PLAN

SHEET  
03

JOB NO.	DATE	DRAWN	CHECKED	APPROVED
2021-0318	1/10/2022	PAG	MER	MER



**CRANSTON**  
ENGINEERING



REFER TO MUTCD  
HANDICAP PARKING  
N.T.S.

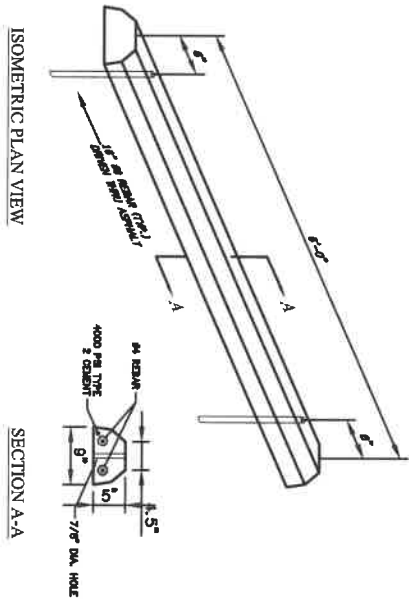

WHEEL STOP  
N.T.S.

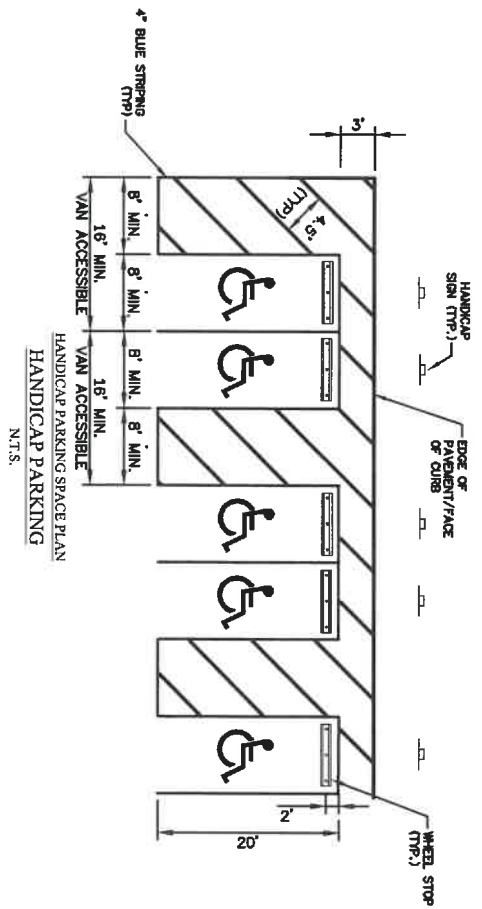

HANDICAP PARKING SPACE PLAN  
HANDICAP PARKING  
N.T.S.



COLLETON COUNTY MIDDLE SCHOOL PARKING LOT PAVING					
PAVEMENT MARKING DETAILS					
JOB NO. 2021-0318	DATE 1/10/2022	<table border="1"> <tr> <td>DRAWN PAG</td> <td>CHECKED MER</td> <td>APPROVED MER</td> </tr> </table>	DRAWN PAG	CHECKED MER	APPROVED MER
DRAWN PAG	CHECKED MER	APPROVED MER			

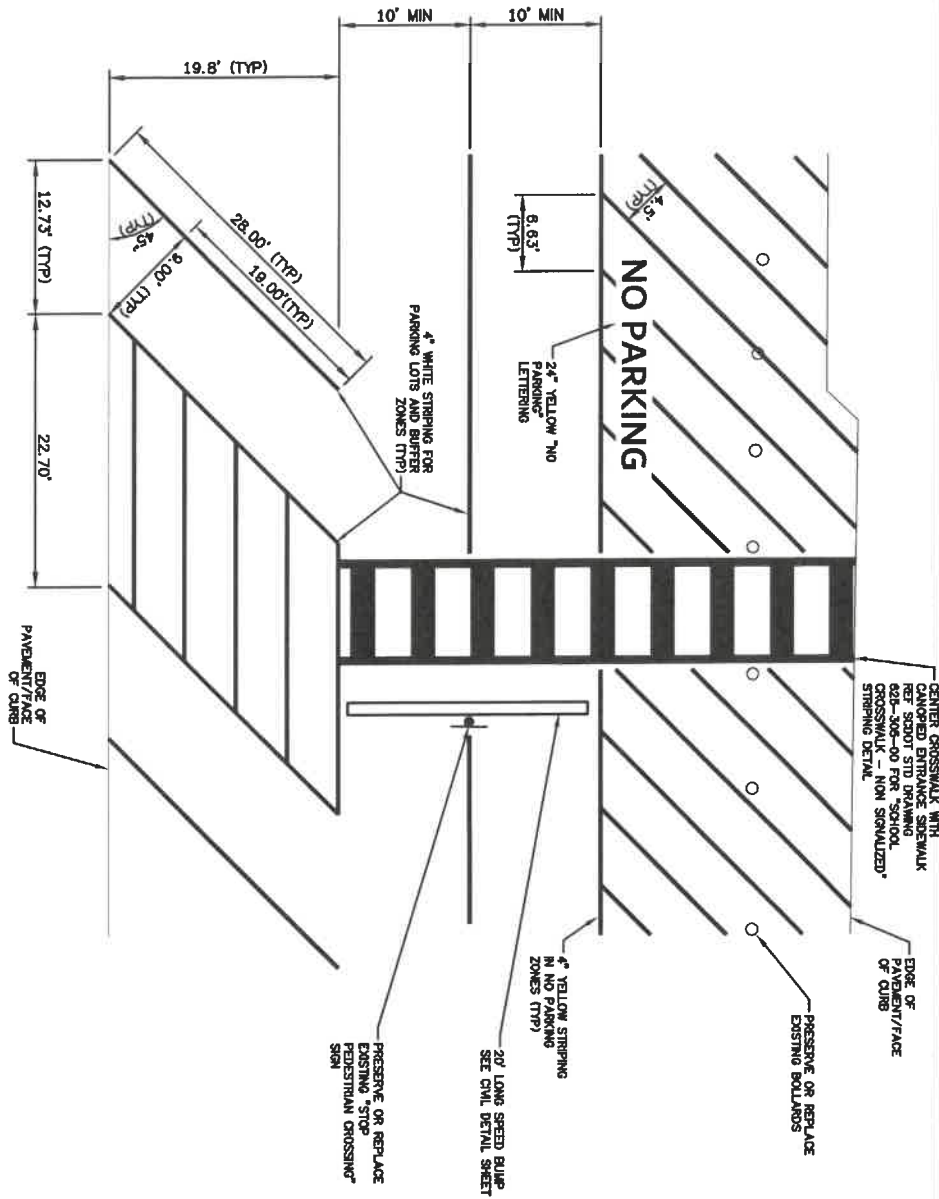

STRIPING DETAILS  
N.T.S.

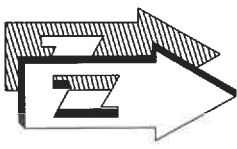

05  
SHEET

COLLETON COUNTY MIDDLE SCHOOL PARKING LOT PAVING

PAVEMENT MARKING DETAILS

JOB NO.	DATE	DRAWN	CHECKED	APPROVED
2021-0318	1/10/2022	PAG	MER	MER



**CRANSTON**  
ENGINEERING

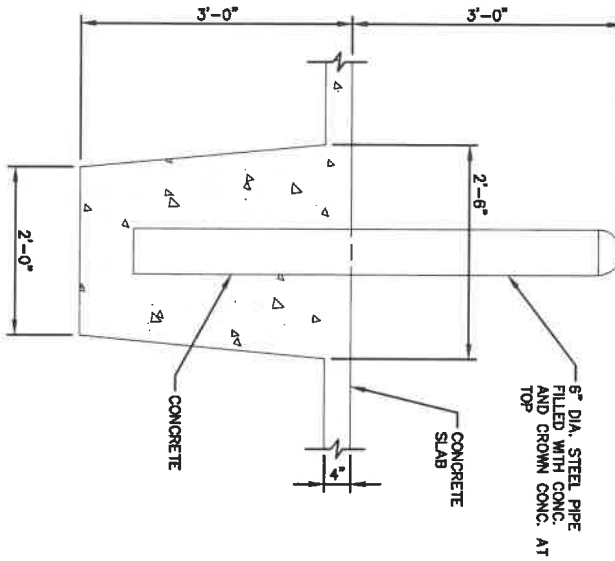

**BOLLARD DETAIL**  
N.T.S.

6" DIA. STEEL PIPE  
FILLED WITH CONC.  
AND GROWN CONC. AT  
TOP

CONCRETE  
SLAB

CONCRETE

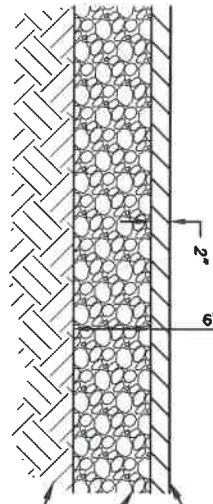

**STANDARD DUTY ASPHALT PAVEMENT**  
N.T.S.

HOT MIX ASPHALT SURFACE COURSE, TYPE B  
150LB/SY

6" OF GRADED AGGREGATE BASE COURSE COMPACTED TO 98%  
MAXIMUM DRY DENSITY. MATERIALS & COMPACTION SHALL BE IN  
ACCORDANCE WITH SECTION 205 OF THE SOUTH CAROLINA  
DEPARTMENT OF TRANSPORTATION SPECIFICATIONS, LATEST EDITION.

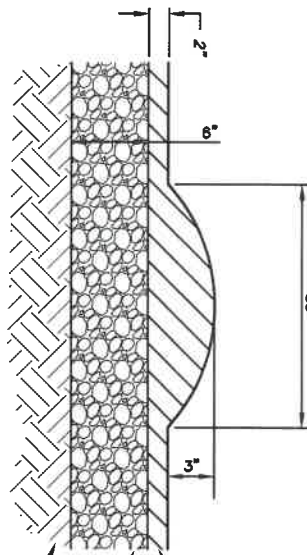

**ASPHALT SPEED BUMP DETAIL**  
N.T.S.

HOT MIX ASPHALT SURFACE COURSE, TYPE B

6" OF GRADED AGGREGATE BASE COURSE COMPACTED TO 98%  
MAXIMUM DRY DENSITY. MATERIALS & COMPACTION SHALL BE IN  
ACCORDANCE WITH SECTION 205 OF THE SOUTH CAROLINA  
DEPARTMENT OF TRANSPORTATION SPECIFICATIONS, LATEST EDITION.



COLLETON COUNTY MIDDLE SCHOOL PARKING LOT PAVING

CIVIL DETAILS

JOB NO. 2021-0318 DATE 1/10/2022

DRAWN BY PAG CHECKED BY MER APPROVED BY MER



**CRANSTON**  
ENGINEERING

06 SHEET

**PROPOSAL  
AND SPECIFICATIONS**

**FOR**

**THUNDERBOLT CAREER AND TECHNOLOGY  
CENTER PAVING**

**WALTERBORO, SOUTH CAROLINA**

Prepared for:

**COLLETON COUNTY SCHOOL DISTRICT  
WALTERBORO, SOUTH CAROLINA**

Prepared by:



**CRANSTON**

Engineered with Integrity

January 10, 2022

CEG# 2021-0330

## Table of Contents

DESCRIPTION OF WORK .....	1
NOTICE TO CONTRACTORS .....	2
SPECIAL PROVISIONS.....	4
1. Thunderbolt Career and Technology Center Paving Project Manager .....	5
2. Examination of Proposal or Plans.....	5
3. Section 101 (Definition and Terms) .....	5
4. Section 107 Legal Relations and Responsibility to the Public .....	6
5. Insurance Requirements.....	6
6. Contractor's Liability Insurance .....	7
7. Award of Contract .....	7
8. Claims Procedure .....	7
9. Contractor Activity Work Schedule .....	7
10. Prompt Payment Clause.....	8
11. Qualified Product Listings.....	8
12. Coordination of Utility Relocation Work with Highway Construction.....	8
13. Required Media Notification .....	8
14. Contract Provisions to Require Certification and Compliance Concerning Illegal Aliens.....	9
15. Subletting of Contracts (Specialty Items).....	9
16. Paving Operations.....	9
17. Retainage .....	9
18. Rate of Application.....	10
19. Dressing of Shoulders.....	10
20. Cement Modified Recycled Base .....	10
21. Transportation and Delivery of Mixes.....	10
22. Sloped Edge Longitudinal Shoulder Joints.....	10
23. Manual on Uniform Traffic Control Devices .....	10
24. Traffic Control .....	11
25. Erosion Control Measures .....	21
26. Permanent Grassing for Small Projects .....	21
27. Removal of Existing Asphalt Pavement Before Patching .....	21
28. Asphalt Binder and Additives.....	21
29. Asphalt Inspection and Material Testing.....	21
30. Basis of Award .....	21
SUPPLEMENTAL SPECIFICATIONS.....	22
PROPOSAL SECTION .....	23
PROPOSAL ITEMS AND QUANTITIES .....	51
PROPOSAL FORM .....	52
CERTIFICATION FORM.....	53
NOTICE OF AWARD .....	54
AGREEMENT .....	55

PERFORMANCE BOND ..... 58  
LABOR AND MATERIAL PAYMENT BOND..... 60  
PROJECT PLANS ..... 64



---

I certify that this Proposal was  
compiled under my supervision

## **THUNDERBOLT CAREER AND TECHNOLOGY CENTER PAVING**

### **DESCRIPTION OF WORK**

The scope of work consists of the removal of the existing asphalt surface, paving, and striping. All areas will be paved 2 inches thick, per detail. Finished grades shall match existing – provide positive drainage. Signage shall be salvaged or replaced in kind. The work will be performed at the Thunderbolt Career and Technology Center located at 1069 Thunderbolt Drive, Walterboro, South Carolina 29488. Traffic control and other incidental items shall be included as shown in the specifications.



## **THUNDERBOLT CAREER AND TECHNOLOGY CENTER PAVING NOTICE TO CONTRACTORS**

Notice is hereby given that sealed proposals for parking lot improvements for THUNDERBOLT CAREER AND TECHNOLOGY CENTER will be received by Colleton County School District – District Office (Attn: Kenny Blakeney, Director of Building & Grounds located at **500 Forest Circle, Walterboro, SC 29488** until 11:00 a.m. (Local Time) February 10, 2022, and then publicly opened and held for further evaluation by the Colleton County School District until an award is made.

Description of work to be done: See Page #1. Work shall be completed within **60** calendar days of the issued Notice to Proceed.

This project is to be constructed under the South Carolina Department of Transportation Standard Specifications, Highway Construction, Edition 2007, and the following Special Provisions.

A 100% performance bond and 100% payment bond will be required.

The Proposal for the work may be examined during regular business hours at wither the **FWA Group's Office (10 Palmetto Business Park Road, Suite 202, Hilton head Island, SC 29928** or **Cranston Engineering Group's Office (14 Westbury Park Way, Suite 202, Bluffton, SC 29910)**

Electronic copies of the Proposals may be obtained by contacting Dale Strecker, AIA at the FWA Group – [d.stecker@fwagroup.com](mailto:d.stecker@fwagroup.com)

All questions shall be submitted in writing to: Matt Randall, PE - [mrandall@cranstonengineering.com](mailto:mrandall@cranstonengineering.com) not less than 5 days before date set for receipt of bids.

The envelope shall be plainly marked with the bidder's name, the project title: **Thunderbolt Career and Technology Center Paving**, Contractor's South Carolina License number, and the date and time for the opening of bids. It is the bidder's sole responsibility to ensure that its bid is received prior to the bid deadline. Any bid received after the scheduled closing time for receipt of bids shall be returned to the bidder unopened. At the time set forth in the Notice for the opening of bids, the sealed bids will be privately opened and evaluated at the place indicated in this Notice.

All proposals otherwise submitted may be rejected as irregular. Only sealed bids will be considered. The right is reserved to reject any or all proposals and waive any technicalities.

All bids (and supporting documents) will be retained by the Colleton County School District General Manager and guaranteed for sixty (60) days from the date the bid is received, and no bids will be received, nor will any Contractor be allowed to withdraw a bid after the opening hour commences.

All bidders must comply with the President's executive Order Numbers 11246 and 1137 which prohibit discrimination in employment regarding race, creed, color, sex or national origin. All bidders must comply with Title VI of the Civil Rights Act of 1964, the Anti-Kickback Act and the Contract Work Hours Standards Act. This also extends to all subcontractors and suppliers. This includes all LEP requirements. Provide a certification of prior work under Executive Order 11246 (Equal Employment Opportunity). Each bidder must make positive efforts to use small and minority

## **THUNDERBOLT CAREER AND TECHNOLOGY CENTER PAVING**

owned business and women business and women business enterprises and provide certification to meet the MBE/WBE "fair share goal/objectives.

# **SPECIAL PROVISIONS**

# **THUNDERBOLT CAREER AND TECHNOLOGY CENTER PAVING**

## **1. Thunderbolt Career and Technology Center Paving Project Manager**

The Contractor is hereby notified that Cranston Engineering Group, P.C. will act as the Thunderbolt Career and Technology Center Paving Engineer and be the Construction Project Manager (PM).

## **2. Examination of Proposal or Plans**

Plan holders desiring further information or interpretation of the Proposal or Plans shall make a written request for such information to Thunderbolt Career and Technology Center Paving Engineer no later than 5 calendar days prior to the bid opening date for the contract. E-mails are accepted at [mrandall@cranstonengineering.com](mailto:mrandall@cranstonengineering.com) or US postal mail by 5:00 p.m. on this date.

Correspondence can be mailed to the following address:

Cranston Engineering Group, P.C.  
14 Westbury Park Way, Suite 202  
Bluffton, SC 29910

The contact person for Cranston Engineering Group, P.C. is:

Matt Randall, PE  
Project Manager  
(843) 352-7770 (Office Phone)  
[mrandall@cranstonengineering.com](mailto:mrandall@cranstonengineering.com)

Modifications to the Proposal or Plans will be made by addendum only. A copy of each addendum will be mailed/e-mailed to the plan holders.

**NOTE:** All required bonds shall be in the name of Colleton County School District, NOT in the name of the South Carolina Department of Transportation.

## **3. Section 101 (Definition and Terms)**

Delete Paragraph 101.3.27 in its entirety and replace with the following:

"101.3.27 Engineer. The Engineer is the Thunderbolt Career and Technology Center Paving Engineer, acting directly or through a duly authorized representative, such representative acting within the scope of particular assigned duties or authority. On this Project the firm of Cranston Engineering Group, P.C., hereinafter referred to as "Project Manager (PM)" shall function as the Engineers duly authorized representative with authority as described in Section 105, "CONTROL OF WORK", of the Standard Specifications for Highway Construction, latest edition. Any reference to the Department or The South Carolina Department of Transportation found in the Standard Specifications, Contract Documents, Special Provisions, Bid Bond, Standard Drawings, etc. shall be interpreted as Cranston Engineering Group, P.C., the Project Manager, and/or Colleton County School District as applicable.

## THUNDERBOLT CAREER AND TECHNOLOGY CENTER PAVING

### 4. Section 107 Legal Relations and Responsibility to the Public

Section 107. 18 (Responsibility for Claims, Etc.)

In the first sentence, add the words "the Colleton County School District, Cranston Engineering Group, P.C., the Project Manager's (PM) representative and/or Engineer" after the word "Department."

### 5. Insurance Requirements

Refer to Section 103.8 of the Standard Specifications Edition 2007 shall apply and add the following supplementary insurance provisions:

A letter of intent from the insurance company or a Certificate of Insurance, acceptable to the Colleton County School District shall be submitted with the Contractor's bid proposal. The letter of intent or Certificate of Insurance shall reflect that the above requirements will be satisfied. **Any proposal that is submitted without a properly completed Letter of Intent or Certificate of Insurance may be considered irregular and may be rejected.**

If the bidder elects to submit a Letter of Intent instead of a Certificate of Insurance, the form furnished along with this proposal may be used for the Letter of Intent. Failure to use the form furnished by the Colleton County School District may result in the bid being declared irregular and the bid may be rejected. The properly completed Letter of Intent may be submitted with the proposal.

A Certificate of Insurance must be submitted to the Project Manager (PM) within ten (10) days of the bid opening. The contract will not be awarded until all necessary insurance requirements have been met.

The Certificate of Insurance shall include Colleton County School District as an additional insured. The authorized insurance company shall provide a Waiver of Subrogation in all policies maintained by the Insured for the performance of the Contract.

The Certificate of Insurance shall provide that the policy cannot be changed to the extent that limits are decreased, canceled or non-renewed without thirty (30) days notice to the Colleton County School District and the (PM). If the Contractor's Insurer changes or cancels the policy, the Contractor shall procure and maintain the required coverage from another Insurer and shall provide a Certificate of Insurance from the new company. Failure to provide coverage from a new company will be grounds to declare a firm in default of the Contract.

Criteria, which shall be necessary in order for Insurance Company or Companies to be deemed satisfactory by the Colleton County School District, shall include, but not be limited to the following:

1. The above required insurance shall be written a Company or Companies licensed in the areas of required coverage by the Chief Insurance Commissioner of the

## **THUNDERBOLT CAREER AND TECHNOLOGY CENTER PAVING**

South Carolina Department of Insurance.

2. The Insurance Company or Companies shall be assigned a rating of "B" or better by A.M. Best Company on its most recent Best's Insurance Report. The Colleton County School District considers the "ACORD Certificate of Insurance" as an acceptable form of certificate.

### **6. Contractor's Liability Insurance**

Refer to Section 103.8 of the Standard Specifications Edition 2007 shall apply and add the following supplementary insurance provisions:

Delete the second sentence in paragraph 4.

Delete the third sentence in paragraph 5, and replace it with the following sentence:

Ensure that all policies contain a provision that coverage afforded under the policies cannot be cancelled or reduced by the Contractor until at least 30 days prior written notice has been provided to Colleton County School District and that the policies cannot be cancelled for non-payment of premiums until at least 10 days prior written notice has been provided to Colleton County School District. Send Notice of Cancellations to Matt Randall, Project Manager, Cranston Engineering Group, P.C., 14 Westbury Park Way, Suite 202, Bluffton, SC 29910.

Add the following as paragraph 6 at the end of Subsection 103.8.

By execution of the contract, the Contractor accepts the responsibility to provide the liability insurance policies and endorsements as specified herein.

Failure of Colleton County School District to identify a deficiency in the Certificate of Insurance submitted by the Contractor's insurance agent as evidence of the specified insurance or to request other evidence of full compliance with the liability insurance specified shall not be construed as a waiver of the Contractor's obligation to provide and maintain the required insurance for the duration of the contract.

### **7. Award of Contract**

Subsection 103.2 of the Standard Specifications Edition 2007 is amended to allow sixty (60) days for the award of a contract after the opening of proposals.

### **8. Claims Procedure**

See attached Supplemental Specification dated **January 1, 2021**. For this project, the Colleton County School District will appoint a Dispute Review sub-committee consisting of 3 members of the committee to evaluate the claim. The general procedures for preparation and submittal of the claim can be seen in the Supplemental Specifications. (Claim Procedure)

### **9. Contractor Activity Work Schedule**

## **THUNDERBOLT CAREER AND TECHNOLOGY CENTER PAVING**

Level 1 – Minimal Schedule Requirement shall be revised as follows:

Provide to the Thunderbolt Career and Technology Center Paving Project Manager a four-week look-ahead schedule identifying planned weekly work activities. Update the schedule every two weeks. **All updates shall be received at least 48 hours prior to the scheduled work activity.** The look-ahead schedule allows the PM to schedule construction engineering and inspection personnel. Colleton County School District and its Project Manager will not be responsible for delays which may be caused by the contractor's failure to abide by his schedule. Failure to submit the look-ahead schedule as specified may result in the withholding of partial payment estimates.

### **10. Prompt Payment Clause**

See attached Supplemental Specification dated **July 1, 2017**.

### **11. Qualified Product Listings**

All references to "Approval Sheet" or "Approval Policy" are to be replaced with "Qualified Products Listings (QPL)" and "Qualified Products Policies (QPP)" respectively. This change includes all references in the SCDOT Standard Drawings, SCDOT Standard Specifications, SCDOT Supplemental Specifications, SCDOT Special Provisions, SCDOT Supplemental Technical Specifications, SCDOT Internet and Intranet websites, and all other documents produced by SCDOT.

### **12. Coordination of Utility Relocation Work with Highway Construction**

As it is not economically feasible to complete the rearrangement of all utility conflicts in advance of the highway construction, such rearrangements may be underway concurrently with construction.

**It shall be the responsibility of the contractor to inspect the site for potential utility conflicts.**

It is the responsibility of the Contractor to call Palmetto Utility Protection Service at 811 or 1: 888-721-7877 three (3) days prior to work so that existing utilities can be properly marked

### **13. Required Media Notification**

Contractors are encouraged to co-operate with the news media since all projects are constructed with public funds. Because the scope of this project will cause disruption of normal traffic flow, the Contractor is required to notify the public, in a timely manner, of disruptive activities such as lane closures.

The Contractor is required to utilize area media to accomplish public notification of traffic disruptions.

The Contractor is required to deal directly with the news media and all reasonable efforts should be made to co-operate with the media. However, the safety, security and construction schedule on site should not be disrupted in order to accomplish this. The

## **THUNDERBOLT CAREER AND TECHNOLOGY CENTER PAVING**

Contractor may co-ordinate these activities with and receive guidance from the SCDOT Public Affairs Office.

### **14. Contract Provisions to Require Certification and Compliance Concerning Illegal Aliens**

By submission of this bid, the bidder as the prime contractor does hereby agree:

1. to certify its compliance with the requirements of Chapter 14 of Title 8 of the S.C. Code of Laws regarding Unauthorized Aliens and Public Employment;
2. to provide SCDOT with any documents required to establish such compliance upon request; and
3. to register and participate and require agreement from subcontractors and sub-subcontractors to register and participate in the federal work authorization program to verify the employment authorization of all new employees, or to employ only workers who supply the documents required pursuant to S.C. Code 8-14-20(8)(2).

### **15. Subletting of Contracts (Specialty Items)**

The following items of work, when not performed by the Prime Contractor, will be designated as Specialty Items in all contracts in which the item does not constitute thirty percent (30%) or more of the original contract value:

Pavement Markings	Permanent Roadway Signs
Guardrail	Signalization
Milling Asphalt Pavement	Electrical/Lighting
Grassing	Specialized Retaining Walls
Landscaping	Fencing
Erosion Control	Right of Way Surveying
Permanent Construction Signs	Railroad Track Work
Utilities	Jack and Boring
Contaminated Soil & Tank Removal	Bridge Floor Grooving Bridge
Barrier Walls	Milled Rumbled Strips
Traffic Count Stations	Buildings
Drilled Shafts & Casings	Navigational Lighting
Pier Fender Systems	Sound Barrier Walls

### **16. Paving Operations**

The asphalt overlay shall be applied in two separate and distinct operations, each operation representing about one-half of the roadway width and traffic shall be maintained continuously. Unless otherwise directed by the Engineer, paving operations shall be scheduled such that the length of the longitudinal joint exposed to traffic shall not extend beyond the length of pavement placed in one normal days operation before dropping back to bring the adjacent lane forward.

### **17. Retainage**



## **THUNDERBOLT CAREER AND TECHNOLOGY CENTER PAVING**

If the Contractor's progress is judged to be delinquent or portions of the work are defective, Colleton County School District reserves the right to withhold retainage. The total amount retained will be sufficient to cover anticipated liquidated damages and the cost to correct defective work.

### **18. Rate of Application**

The pounds per square yard specified are set up as an average rate of application. The Engineer may direct variations wherever conditions warrant.

### **19. Dressing of Shoulders**

Prior to the placement of asphalt concrete mixtures on existing roadways, the Contractor will be required to remove any vegetation adjacent to the edge of pavement which impedes the placement the asphalt mixture to the specified width. After the asphalt mixture has been placed, the Contractor shall blade the disturbed material to the extent that the shoulder is left in a neat and presentable condition. Any excess material shall be removed from the project. No direct payment shall be made for this work, but the costs shall be included in the price of other items of work.

### **20. Cement Modified Recycled Base**

See attached Supplemental Technical Specification SC-M-306. Curing Method 4: Surface Treatment and Surface Planing shall be utilized as the curing method for all roads in this contract. Section 301.4.13 Maintenance of the Standard Specifications shall be revised to include the following:

"Once the minimum 72-hour curing process is complete, the contractor will be required within 21 calendar days to place the final asphalt riding surface.

### **21. Transportation and Delivery of Mixes**

See attached Supplemental Specification dated **July 1, 2010**.

### **22. Sloped Edge Longitudinal Shoulder Joints**

See attached Supplemental Specification dated **July 1, 2019**.

### **23. Manual on Uniform Traffic Control Devices**

The Contractor is advised that all work involving design or installation of traffic control devices, including but not limited to signs, pavement markings, elements of work zone traffic control, signals, etc., shall be in compliance with the FHWA's Manual on Uniform Traffic Control Devices (MUTCD), latest edition. The latest edition is defined as the edition that the Traffic Engineering Division of SCDOT recognizes as having been officially adopted (Engineering Directive, Memorandum 19) at the time the project is let, unless stated otherwise in the Special Provisions.

# THUNDERBOLT CAREER AND TECHNOLOGY CENTER PAVING

## 24. Traffic Control

The Contractor shall execute the item of Traffic Control as required by the Standard Specifications, the plans, the Standard Drawings for Road Construction, these special provisions, all supplemental specifications, the MUTCD, and the Engineer. This is an amendment to the Standard Specifications to require the following:

### **GENERAL REGULATIONS –**

These special provisions shall have priority to the plans and comply with the requirements of the MUTCD and the standard specifications. Revisions to the traffic control plan through modifications of the special provisions and the plans shall require approval by the department. Final approval of any revisions to the traffic control plan shall be pending upon review by Colleton County School District.

Install and utilize changeable message signs in all lane closures installed on high volume high-speed multilane roadways. Use of changeable message signs in lane closures installed on low volume low speed multilane roadways is optional unless otherwise directed by the plans and the Engineer. Install and use a changeable message sign within a lane closure set-up as directed by the *Standard Drawings for Road Construction*. When a lane closure is not present for any time to exceed 24 hours, remove the changeable message sign from the roadway. Place the sign in a predetermined area on the project site, as approved by the Engineer, where the sign is not visible to passing motorists. The preprogrammed messages utilized shall be in accordance with the *Standard Drawings for Road Construction* when used as part of the traffic control set-up for lane closures. Only those messages pertinent to the requirements of the traffic control situation and the traffic conditions are permitted for display on a changeable message sign at all times. At no time will the messages displayed on a changeable message sign duplicate the legends on the permanent construction signs.

During operation of changeable message signs, place the changeable message sign on the shoulder of the roadway no closer than 6 feet between the sign and the near edge of the adjacent travel lane. When the sign location is within 30' of the near edge of a travel lane open to traffic, supplement the sign location with no less than 5 portable plastic drums placed between the sign and the adjacent travel lane for delineation of the sign location. Install and maintain the drums no closer than 3 feet from the near edge of the adjacent travel lane. This requirement for delineation of the sign location shall apply during all times the sign location is within 30' of the near edge of a travel lane open to traffic, including times of operation and non-operation. Oversized cones are prohibited as a substitute for the portable plastic drums during this application.

**All signs mounted on portable sign supports shall have a minimum mounting height of 5' from the bottom of the sign to the ground. All signs mounted on ground mounted u-channel posts or square steel tube posts shall have a minimum mounting height of 7' from the bottom of the sign to the grade elevation of the near edge of the adjacent travel lane or sidewalk when a sidewalk is present.**

**On multilane primary routes, avoid placement of signs mounted on portable sign**

## **THUNDERBOLT CAREER AND TECHNOLOGY CENTER PAVING**

**supports within paved median areas utilized for two-way left turns unless otherwise directed by the RCE.**

**When mounting signs on multiple ground mounted sign supports, ensure that each post is of the same type. Combining and installing both ground mounted u-section and square steel tube posts within the same sign assembly is prohibited.**

**When mounting signs on ground mounted u-section or square steel tube posts, utilize either a sign support / ground support post combination with an approved breakaway assembly or a single direct driven post for each individual sign support of a sign assembly installation. Do not combine a sign support/ ground support post combination and a direct driven post on the same sign assembly installation that contains two or more sign supports. Regarding sign support / ground support post combination installations, ensure that post lengths, stub heights and breakaway assemblies comply with the manufacturer's requirements and specifications. Use approved breakaway assemblies found on the *Approved Products List for Traffic Control Devices in Work Zones*.**

**Temporary "Exit" signs (M1025-00) shall be located within each temporary gore during lane closures on multilane roadways. Mount these signs a minimum of 7' from the pavement surface to the bottom of the sign in accordance with the requirements of the MUTCD.**

**When covering signs with opaque materials, the Department prohibits attaching a covering material to the face of the sign with tape or a similar product or any method that will leave a residue on the retroreflective sheeting. Residue from tape or similar products, as well as many methods utilized to remove such residue, damages the effective reflectivity of the sign. Therefore, contact of tape or a similar product with the retroreflective sheeting will require replacement of the sign. Cost for replacement of a sign damaged by improper covering methods will be considered incidental to providing and maintaining the sign; no additional payment will be made.**

**Overlays are prohibited on all rigid construction signs. The legends and borders on all rigid construction signs shall be either reversed screened or direct applied.**

**Signs not illustrated on the typical traffic control standard drawings designated for permanent construction signs shall be considered temporary and shall be included in the lump sum price bid item for "Traffic Control" unless otherwise specified.**

**Install "Grooved Pavement" signs (W8-15-48) supplemented with the "Motorcycle" plaque (W8-15P-30) in advance of milled or surface planed pavement surfaces. On primary routes, install these signs no further than 500 feet in advance of the beginning of the pavement condition. On interstate routes, install these signs no less than 500 feet in advance of the beginning of the pavement condition.**

**Install two sign assemblies at each sign location, one on each side of the roadway, on multilane roadways when the pavement condition is present. Install these signs immediately upon creation of this pavement condition and maintain these signs**

## **THUNDERBOLT CAREER AND TECHNOLOGY CENTER PAVING**

until this pavement condition is eliminated.

**Install "Steel Plate Ahead" signs (W8-24-48) in advance of an area of roadway where temporary steel plates are present. Install these signs no further than 300 feet in advance of locations where steel plates are present. On multilane roadways, comply with the same guidelines as applied to all other advance warning signs and install two sign assemblies at each sign location, one on each side of the roadway, when roadway conditions warrant. Install these signs immediately upon installation of a temporary steel plate and maintain the signs until the temporary steel plates are removed.**

Install and maintain any necessary detour signing as specified by the typical traffic control standard drawings designated for detour signing, Part VI of the MUTCD, these Special Provisions, and the Engineer. The lump sum price bid item for "Traffic Control" includes payment for installation and maintenance of the detour signing.

The Contractor shall maintain the travel patterns as directed by the traffic control plans and shall execute construction schedules expeditiously. The Contractor shall provide the Resident Engineer with no less than a two-week prior notification of changes in traffic patterns.

**During nighttime flagging operations, flaggers shall wear a safety vest and safety pants that comply with the requirements of ANSI/ISEA 107 standard performance for Class 3 risk exposure, latest revision, and a fluorescent hard hat. The safety vest and the safety pants shall be reflectorized, and the color of the background material of the safety vest and safety pants shall be fluorescent orange-red or fluorescent yellow-green.**

**During nighttime flagging operations, the contractor shall illuminate each flagger station with any combination of portable lights, standard electric lights, existing streetlights, etc., that will provide a minimum illumination level of 108 Lx or 10fc.**

During nighttime flagging operations, supplement the array of advance warning signs with a changeable message sign for each approach. These changeable message signs are not required during daytime flagging operations. Install the changeable message signs 500' in advance of the advance warning sign arrays. Messages should be "Flagger Ahead" and "Prepare to Stop".

**During sidewalk repair operations, the Department requires lane closures at all times where the sidewalk is adjacent to the travel lanes of a roadway opened to traffic, unless otherwise specified by these special provisions. Maintain lane closure restrictions at all times unless otherwise directed by these special provisions.**

**During surface Planing and milling operations, grade elevation differences greater than 1 inch in areas with pavements composed of hot mixed asphalt (HMA) base courses, intermediate courses or surface courses and Portland cement concrete are PROHIBITED unless otherwise directed by the Department. However, during surface planing and milling operations for removal of Open-Graded Friction**

## **THUNDERBOLT CAREER AND TECHNOLOGY CENTER PAVING**

**courses ONLY, a grade elevation difference of 1½ inches between adjacent travel lanes opened to traffic may exist unless otherwise directed by the Department.**

Supplement and delineate the shoulder edges of travel lanes through work zones with traffic control devices to provide motorists with a clear and positive travel path. Utilize portable plastic drums unless otherwise directed by the Department. Vertical panels may be used where specified by the plans and directed by the RCE. The installation of traffic control devices is required in all areas where those areas immediately adjacent to a travel lane open to traffic have been altered in any manner by work activities, including but not limited to activities such as grading, milling, etc. Install the traffic control devices immediately upon initiating any alterations to the areas immediately adjacent to or within 15 feet of the near edge line of the adjacent travel lane. When sufficient space is available, place the traffic control devices no closer than 3 feet from the near edge of the traffic control device to the near edge line on the adjacent travel lane. When sufficient space is unavailable, place the traffic control device at the maximum distance from the near edge of the adjacent travel lane available.

### **LANE CLOSURE RESTRICTIONS**

**The lane closure restrictions stated below are project specific, for all other restrictions, see supplemental specification, "Restrictions", dated January 3, 2013.**

The Contractor shall install all lane closures as directed by the Standard Specifications for Highway Construction (Edition of 2000), the Standard Drawings for Road Construction, these special provisions, the MUTCD, and the Engineer. The Contractor shall close the travel lanes of two-lane two-way roadways by installing flagging operations. The Contractor shall close the travel lanes of multilane roadways as directed by the typical traffic control standard drawings designated for lane closures on primary routes.

**The Department prohibits lane closures on primary routes during any time of the day that traffic volumes exceed 800 vehicles per hour per direction. The Department reserves the right to suspend a lane closure if any resulting traffic backups are deemed excessive by the Engineer. Maintain all lane closure restrictions as directed by the plans, these special provisions, and the Engineer.**

**Flagging operations are considered to be lane closures for two-lane two-way operations and shall be subject to all restrictions for lane closures as specified by this contract.**

**Lane closures, including flagging operations, are restricted to maximum distances of 2 miles. Install all lane closures according to the typical traffic control standard drawings. On occasions when daytime lane closures must be extended into the nighttime hours, substitute the nighttime lane closure standards for the daytime lane closure standards.**

**The Department reserves the right to suspend a lane closure if any resulting traffic backups are deemed excessive by the Engineer. Maintain all lane closure restrictions as directed by the Standard Specifications, these special provisions,**

## **THUNDERBOLT CAREER AND TECHNOLOGY CENTER PAVING**

and the Engineer.

Installation and maintenance of a lane closure is **PROHIBITED** when the Contractor is not actively engaged in work activities specific to the location of the lane closure unless otherwise specified and approved by the Engineer. The length of the lane closure shall not exceed the length of roadway anticipated to be subjected to the proposed work activities within the work shift time frame or the maximum lane closure length specified unless otherwise approved by the Engineer. Also, the maximum lane closure length specified does not warrant installation of the specified lane closure length when the length of the lane closure necessary for conducting the work activity is less.

The length and duration of each lane closure, within the specified parameters, shall require approval by the Engineer prior to installation. The length and duration of each lane closure may be reduced by the Engineer if the work zone impacts generated by a lane closure are deemed excessive or unnecessary.

The presence of temporary signs, portable sign supports, traffic control devices, trailer mounted equipment, truck mounted equipment, vehicles, and vehicles with trailers relative to the installation or removal of a closure and personnel are prohibited within the 15 to 30 foot clear zone based upon the roadway speed limit during the prohibitive hours for lane closures specified by these special provisions.

### **TYPICAL TRAFFIC CONTROL STANDARD DRAWINGS -**

The typical traffic control standard drawings of the "Standard Drawings for Road Construction", although compliant with the MUTCD, shall take precedence over the MUTCD. The typical traffic control standard drawings of the "Standard Drawings for Road Construction" shall apply to all projects let to contract.

Install the permanent construction signs as shown on the typical traffic control standard drawings designated for permanent construction signing.

### **ADDENDUMS**

(Addendums to the "2001 Standard Specifications for Highway Construction")

#### **(A) Construction (Sub-section 601.4) -**

##### **Sub-section 601.4.2 Construction Vehicles (paragraph 2)-**

When working within the rights-of-way of access-controlled roadways such as Interstate highways, the Contractor's vehicles may only change direction of travel at interchanges. These vehicles are prohibited from crossing the roadway from right side to median or vice versa. Use a flagger to control the Contractor's vehicles when these vehicles attempt to enter the roadway from a closed lane or the median area. Ensure that the flagger does not stop traffic, cause traffic to change lanes, or affect traffic in any manner. The Contractor's vehicles may not disrupt the normal flow of traffic or enter the travel lane of the roadway until a sufficient gap is present.

The Contractor shall have flaggers available to control all construction vehicles entering or crossing the travel lanes of secondary and primary routes. The RCE shall determine the necessity of these flaggers for control of these construction vehicles. The RCE shall

## THUNDERBOLT CAREER AND TECHNOLOGY CENTER PAVING

consider sight distance, vertical and horizontal curves of the roadway, prevailing speeds of traffic, frequency of construction vehicles entering or crossing the roadway, and other site conditions that may impact the safety of the workers and motorists when determining the necessity of these flaggers. Ensure that these flaggers do not stop traffic, cause traffic to change lanes, or affect traffic in any manner. The Contractor's vehicles may not disrupt the normal flow of traffic or enter the travel lane of the roadway until a sufficient gap is present.

When working within the rights-of-way of access-controlled roadways with posted regulatory speed limits of 55 MPH or greater and average daily traffic volumes (ADT) of 10,000 vehicles per day or greater, i.e., Interstate highways, all construction and work vehicles possessing any one or more of the vehicular characteristics listed below are only permitted to enter and exit a right or left shoulder work area during the presence of active lane closures unless otherwise directed by the RCE. These vehicles are not permitted to enter or exit these work areas without the presence of active lane closures unless otherwise directed by the RCE. Shoulder closures are unacceptable and insufficient methods for control of traffic at ingress / egress areas for these vehicles. The restrictive vehicular characteristics include the following:

- Over six (6) tires
- Tandem rear axles
- A base curb weight greater than 8000 lbs.
- A gross vehicular weight greater than 12000 lbs. unless performing duties as a shadow vehicle while supporting a truck mounted attenuator
- A trailer in tow except under the following conditions:
  - Trailers transporting traffic control devices (including but not limited to standard and 42" oversized traffic cones, portable plastic drums, signs, portable sign supports, u-channel and square steel tube signposts) relative to the installation of lane closures, shoulder closures or other traffic control operations approved by the RCE
  - Trailer mounted traffic control devices (including but not limited to advance warning arrow panels, changeable message signs, temporary traffic signals, highway advisory radios, work zone intelligent transportation systems and trailer towed truck mounted attenuators)

### **(B) Construction (Sub-section 601.4) -**

#### **Sub-section 601.4.2 Construction Vehicles - Auxiliary Warning Lights for Vehicles and Equipment -**

Supplement all construction and/or construction-related vehicles and equipment that operate in a stationary or mobile work zone within or adjacent to a roadway within the highway rights-of-way with AMBER or YELLOW colored high intensity rotating or strobe type flashing auxiliary warning light devices. Utilize, install, operate and maintain a single or multiple lighting devices as necessary to provide visibility to approaching motorists.

All auxiliary warning light models shall meet *Society of Automotive Engineers (SAE)* Class standards and SAE Standard J575 relative to *Tests for Motor Vehicle Lighting*

## THUNDERBOLT CAREER AND TECHNOLOGY CENTER PAVING

*Devices and Components* and these specifications. The amber/yellow color of the dome/lens of an auxiliary warning light device shall meet SAE Standard J578 for amber/yellow color specifications.

Auxiliary warning lights with parabolic reflectors that rotate shall rotate around a halogen lamp at a rate to produce approximately 175 flashes per minute. The parabolic reflector shall produce a minimum 80,000 candle power and a minimum 54,000 candela through an SAE Standard J846 approved amber dome.

Equip strobe type flashing auxiliary warning light devices with photosensitive circuit controls to adjust the lighting intensity in response to changes in ambient light conditions such as from day to night. These lights shall have a double-flash capability rated at approximately 80 double flashes per minute and produce a minimum 24 joules of flash energy at the highest power level setting.

Acceptable auxiliary warning light models shall provide sufficient light output to be clearly recognizable at a minimum distance of 1750 feet.

Mount all auxiliary warning light devices intended to function as the auxiliary warning light system or as an element thereof on vehicles and equipment at locations no less than 3 feet above the ground and in conspicuous locations to provide visibility to approaching motorists.

Auxiliary warning light devices and/or models that mount in the locations of the standard vehicle lighting system are unacceptable as the specified auxiliary warning light system due to restrictive simultaneous visibility capabilities from multiple sight angles. However, auxiliary warning light devices that mount in the standard vehicle lighting system locations are acceptable as supplements to the specified lighting devices mounted in locations that do meet the minimum height requirements and provide simultaneous visibility capabilities from multiple sight angles.

Standard vehicle hazard warning lights are only permitted as supplements to the specified auxiliary warning light devices.

### **(C) Category I Traffic Control Devices (Section 603)-**

**\*\*\* (Effective on all projects let to contract after May 1, 2010)**

#### **Sub-section 603.2.2 Oversized Traffic Cones (paragraph 6)-**

Reflecterize each oversized traffic cone with 4 retroreflective bands: 2 orange and 2 white retroreflective bands. Alternate the orange and white retroreflective bands, with the top band always being orange. Make each retroreflective band not less than 6 inches wide.

Utilize Type III - Microprismatic retroreflective sheeting for retroreflectorization on all projects let to contract after May 1, 2010 unless otherwise specified. Separate each retroreflective band with not more than a 2-inch non-reflecterized area. Do not splice the retroreflective sheeting to create the 6- inch retroreflective bands. Apply the retroreflective sheeting directly to the cone surface. Do not apply the retroreflective sheeting over a pre-existing layer of retroreflective sheeting.



## **THUNDERBOLT CAREER AND TECHNOLOGY CENTER PAVING**

### **Sub-section 603.2.3                      Portable Plastic Drums                      (paragraph 3)**

Reflectorize each drum with Type III - Microprismatic retroreflective sheeting: 2 orange and 2 white retroreflective bands, 6 inches wide on all projects let to contract after May 1, 2010 unless otherwise specified. Alternate the orange and white retroreflective bands with the top band always being orange. Ensure that any non-reflectorized area between the orange and white retroreflective bands does not exceed 2 inches. Do not splice the retroreflective sheeting to create the 6-inch retroreflective bands. Apply the retroreflective sheeting directly to the drum surface. Do not apply the retroreflective sheeting over a pre-existing layer of retroreflective sheeting.

### **(D) Category II Traffic Control Devices (Section 604)-**

**\*\*\* (Effective on all projects let to contract after May 1, 2012)**

### **Sub-section 604.2.1                      Type I and Type II Barricades                      (paragraph 3)**

Reflectorize these barricades with Type VIII or IX Prismatic retroreflective sheeting on all projects let to contract after May 1, 2012 unless otherwise specified. Ensure that the retroreflective sheeting has alternate orange and white stripes sloping downward at a 45-degree angle in the direction of passing traffic. The stripes shall be 6 inches wide.

### **Sub-section 604.2.2                      Type III Barricades                      (paragraph 3)**

Reflectorize these barricades with Type VIII or IX Prismatic retro reflective sheeting on all projects let to contract after May 1, 2012 unless otherwise specified. Ensure that the retroreflective sheeting has alternate orange and white stripes sloping downward at a 45-degree angle. Apply the sloping orange and white stripes in accordance with the requirements of the Plans, SCOOT Standard Drawings and the MUTCD. The stripes shall be 6 inches wide.

### **(E) Temporary Concrete Barrier (Sub-section 605.2.3.2)-**

### **Sub-section 605.2.3.2                      Temporary Concrete Barrier                      (paragraph 6)**

Previously used temporary concrete barrier walls are subject to inspection and approval by the RCE before use. Ensure that previously used temporary concrete barrier walls are in good condition. Defects to a temporary concrete barrier wall that may disqualify a section of wall for use include gouges, cracks, chipped, or spalled areas. A defect that exposes reinforcing steel warrants immediate disqualification. A disqualification grade type defect shall consist of measurements in excess of 1 inch, entirely or partially within the boundaries of the end connection areas and the drainage slot areas as illustrated in the "Standard Drawings for Road Construction", and/or in excess of 4 inches for all areas beyond the end connection areas. To warrant disqualification, these measurements shall exceed the specified dimensions in all three directions, width, height, and depth. A defect that exceeds the specified dimensions in only one or two of the three directions does not warrant disqualification.

Temporary concrete barrier walls with defects less than 6 inches in all three directions, width, height, and depth that do not expose reinforcing steel may be repaired in accordance with the following requirements. Repair is prohibited on temporary concrete barrier walls with defects 6 inches or greater in all three directions, width, height, and depth.

For repair of temporary concrete barrier walls with defects less than 6 inches in all three

## **THUNDERBOLT CAREER AND TECHNOLOGY CENTER PAVING**

directions, width, height, and depth that do not expose reinforcing steel, repair the defect with a premanufactured patching material specifically fabricated for patching structural concrete. The strength of the patch must meet or exceed the design strength of the class 3000 concrete of the temporary concrete barrier wall. Perform the repair procedures in accordance with all requirements and instructions from the manufacturer of the patch material. Use a bonding compound between the patch material and the concrete unless specifically stated by the manufacturer that a bonding compound is not required. If the manufacturer states that application of a bonding compound is optional, SCOOT requires application of a bonding compound compatible with the patch material. If cracking occurs within the patched area, remove the patch material completely and repeat the repair process.

The contractor shall submit documentation stating all repairs have been conducted in accordance with these requirements prior to installing any temporary concrete barrier walls with repairs. Utilization of temporary concrete barrier walls with repairs shall require approval by the RCE prior to installation.

The Contractor shall submit certification documents for the patch material utilized for repairs to the Engineer prior to placing temporary concrete barrier walls that have been repaired on the project site.

### **(F) Truck-Mounted Attenuator (Sub-section 605.4.2.2) –**

#### **Sub-section 605.2.2.2.3.3 Color (paragraph 1)–**

Use industrial grade enamel paint for cover of the metal aspects of the unit. Provide and attach supplemental striping to the rear face of the unit with a minimum Type III high intensity retroreflective sheeting unless otherwise directed by the Department. Utilize an alternating 4 to 8 inch black and 4 to 8 inch yellow 45-degree striping pattern that forms an inverted "V" at the center of the unit that slopes down and to the sides of the unit in both directions from the center.

### **(G) Truck-Mounted Attenuator (Sub-section 605.4.2.2) -**

#### **Sub-section 605.4.2.2 Truck-Mounted Attenuators (paragraph 6)–**

Attach each truck-mounted attenuator to the rear of a truck with a minimum gross vehicular weight (GVW) of 15,000 pounds (actual weight). If the addition of supplemental weight to the vehicle as ballast is necessary, contain the material within a structure constructed of steel. Construct this steel structure to have a minimum of four sides and a bottom to contain the ballast material in its entirety. A top is optional. Bolt this structure to the frame of the truck. Utilize a sufficient number of fasteners for attachment of the steel structure to the frame of the truck to ensure the structure will not part from the frame of the truck during an impact upon the attached truck mounted attenuator. Utilize either dry loose sand or steel reinforced concrete for ballast material within the steel structure to achieve the necessary weight. The ballast material shall remain contained within the confines of the steel structure and shall not protrude from the steel structure in any manner.

### **(H) Trailer-Mounted Changeable Message Signs (Sub-section 606.3.2) –**

#### **Sub-section 606.5 Measurement (paragraph 2)–**

Trailer-mounted changeable message signs are included in the lump sum item for Traffic

## THUNDERBOLT CAREER AND TECHNOLOGY CENTER PAVING

Control in accordance with Subsections 107.12 and 601.5 of the "2007 Standard Specifications for Highway Construction". No separate measurement will be made for trailer-mounted changeable message signs unless the contract includes a specific pay item for trailer-mounted changeable message signs. The Contractor shall provide, install, operate, and maintain the trailer-mounted changeable message sign per traffic control set-up as directed by the Plans, the "Standard Drawings for Road Construction", these Special Provisions, the Specifications, and the Engineer.

**Sub-section 606.6 Payment (paragraph 2)-**

In addition to Subsections 107.12 and 601.6, the payment for Traffic Control is full compensation for providing, installing, removing, relocating, operating, and maintaining trailer-mounted advance warning arrow panels and trailer-mounted changeable message signs as specified or directed and includes providing the units' primary power source; repairing or replacing damaged or malfunctioning units within the specified time; providing traffic control necessary for installing, operating, and maintaining the units; and all other materials, labor, hardware, equipment, tools, supplies, transportation, incidentals, and any miscellaneous items necessary to fulfill the requirements of the pay item in accordance with the Plans, the Specifications, and other items of the Contract.

**Sub-section 606.6 Payment (paragraph 3)-**

Disregard this paragraph unless the Contract includes a specific pay item for trailer-mounted changeable message signs.

**(f) Flagging Operations (Sub-section 610.4.1)-**

**Sub-section 610.4.1.1 Flagging Operations (paragraph 1)-**

Use a flagging operation to control the flow of traffic when two opposing directions of traffic must share a common travel lane. A flagging operation may be necessary during a lane closure on a two-lane two-way roadway, an intermittent ramp closure or an intermittent encroachment of equipment onto a portion of the roadway. Utilize flagging operations to direct traffic around work activities and maintain continuous traffic flow at reduced speeds when determined to be appropriate by the RCE. As stated above, flagging operations shall direct traffic around the work activities and maintain continuous traffic flow, therefore, stopped traffic shall not be required to stop for time durations greater than those listed below unless otherwise directed by the RCE.

Length of Closure	Maximum Time Duration for Stopped Traffic
1 MILE or LESS	5 Minutes
1 to 2 MILES	7 ½ Minutes

If the work activities require traffic to be stopped for periods greater than 5 to 7 ½ minutes as stated above, consider alternate work methods, conducting work activities during times of lowest traffic volumes such as during the hours of darkness or complete road closure with detour installation.

# THUNDERBOLT CAREER AND TECHNOLOGY CENTER PAVING

## **(J) Paving and Resurfacing (Sub-section 611.4.1) -**

### **Sub-section 611.4.1.2 Requirements (paragraph 8)-**

Whenever travel lanes with acceptable grade elevation differences are open to traffic, provide "Uneven Lanes" signs (W8-11-48) or "Uneven Pavement" signs (W8-11A-48). Reflectorize these signs with a fluorescent orange colored prismatic retroreflective sheeting unless otherwise specified. Install these signs adjacent to roadways with uneven pavement surfaces between travel lanes or between travel lanes and the adjacent paved shoulders. Install these signs at intervals no greater than 2600 feet.

## **25. Erosion Control Measures**

See attached Supplemental Specification dated **January 1, 2020**.

## **26. Permanent Grassing for Small Projects**

Section 1.3.3 of SC-M-810 SEEDING paragraph two is modified as follows: Permanent Grassing for small projects will require HECP-Type 3 on all applications, unless otherwise noted in the plans or specifications.

## **27. Removal of Existing Asphalt Pavement Before Patching**

See attached Supplemental Specification dated **January 1, 2018**.

## **28. Asphalt Binder and Additives**

See attached Supplemental Specification dated **January 1, 2019**.

## **29. Asphalt Inspection and Material Testing**

See SCDOT Construction Manual, Appendix C, Sampling and Testing Procedures.

## **30. Basis of Award**

The bids will be compared on the basis of unit price, as extended, which will include and cover the furnishing of all materials and the performance of all labor requisite or proper and completing of all the work called for under the accompanying contract, and in the manner set forth and described in the specifications.

Where estimated quantities are included in certain items of the proposal, they are for the purpose of comparing bids. While they are believed to be close approximations, they are not guaranteed, and settlement will be made for such items upon the basis of the work as actually executed at the unit prices in the proposal as accepted. In case of error in the extension of prices in a proposal, unit bid prices shall govern.

# **SUPPLEMENTAL SPECIFICATIONS**

SUPPLEMENTAL SPECIFICATIONS

January 1, 2018

**ERRATA TO 2007 STANDARD SPECIFICATIONS FOR HIGHWAY CONSTRUCTION**

Make the changes listed below to correct errata in the SDCOT *2007 Standard Specifications for Highway Construction*:

**DIVISION 100 GENERAL PROVISIONS**

**SECTION 101 DEFINITIONS AND TERMS**

**Subsection 101.2 Abbreviations and Acronyms**

Amend the table of **SCDOT OFFICIALS AND OFFICES** as follows:

DELETIONS		REPLACEMENTS	
<del>BDE*</del>	<del>Bridge Design Engineer</del>	PSE*	Preconstruction Support Engineer
<del>BDGE*</del>	<del>Bridge Design Geotechnical Engineer</del>	GDSE*	Geotechnical Design Support Engineer
<del>SHE*</del>	<del>State Highway Engineer</del>	DSE*	Deputy Secretary for Engineering

\*Wherever it appears in the text, replace the deleted abbreviation with the new abbreviation.

**SECTION 102 BIDDING REQUIREMENTS AND CONDITIONS**

**Subsection 102.8 Irregular Bids**

Paragraph 2, item E, first sentence; delete the word "the" after the word "When".

**SECTION 105 CONTROL OF WORK**

**Subsection 105.6 Cooperation with Utilities**

Paragraph 1, last sentence; change the word "THE" to "the".

**DIVISION 200 EARTHWORK**

**SECTION 202 REMOVAL OF STRUCTURES AND OBSTRUCTIONS**

**Subsection 202.5 Measurement**

Paragraph 5, second bullet; change the words "Brick sidewalk" to "Concrete, brick or stone sidewalks".

**SECTION 204 STRUCTURE EXCAVATION**

**Subsection 204.2.1.2 Structure Excavation for Culverts**

Paragraph 1, at the end of the first sentence; change "Subsection 204.4" to "Subsection 204.5".

**DIVISION 400 ASPHALT PAVEMENTS**

**SECTION 401 HOT MIXED ASPHALT (HMA) PAVEMENT**

**Subsection 401.2.1.2 Liquid Anti-Stripping Agent**

Paragraph 1, first sentence; delete the period at the end of the sentence and add "and SC-M-406".

**Subsection 401.2.5 Material for Full Depth Patching**

Paragraph 1, delete and replace with the following:

**SUPPLEMENTAL SPECIFICATIONS**

"Use an approved SCDOT Intermediate Type C mix for all Full Depth Patching."

**Subsection 401.5 Measurement**

After paragraph 10, add the following paragraph:

- 11 The measurement of Prime Coat is the number of gallons of asphalt material applied to the completed and accepted base course.

**Subsection 401.6 Payment**

After paragraph 12, add the following paragraph:

- 13 "The payment for Prime Coat is at the contract unit price for Prime Coat and includes compensation for all labor, equipment, tools, maintenance, and incidentals necessary to complete that work."

**Subsection 401.6 Payment**

Paragraph 13, **Table of Pay Items**

Change paragraph reference number "13" to "14" and add the following Pay Item:

Item No.	Pay Item	Unit
4010005	Prime Coat	GAL

**SECTION 403 HMA SURFACE COURSE**

**Subsection 403.5 Measurement**

Paragraph 1, first sentence; change "HMA Intermediate Course" to "HMA Surface Course".

**Subsection 403.6 Payment**

Paragraph 1, first sentence; change "HMA Intermediate Course" to "HMA Surface Course".

**SECTION 407 ASPHALT SURFACE TREATMENT – DOUBLE TREATMENT**

**Subsection 407.5 Measurement**

Paragraph 1, first sentence; add the word "is" after "(Double Treatment Type (1, 2, 3, 4, or 5))".

**SECTION 408 ASPHALT SURFACE TREATMENT – TRIPLE TREATMENT**

**Subsection 408.5 Measurement**

Paragraph 1, first sentence; add the word "is" after "(Triple Treatment Type (1 or 2))".

**DIVISION 600 MAINTENANCE AND TRAFFIC CONTROL**

**SECTION 625 PERMANENT PAVEMENT MARKINGS  
FAST DRY WATERBOURNE PAINT**

**Subsection 625.2.2.4.11 Lead Content**

Paragraph 1, first sentence; change 6% to 0.06%.

**SECTION 627 THERMOPLASTIC PAVEMENT MARKINGS**

**Subsection 627.4.10 Inspection and Acceptance of Work**

Paragraph 2, first sentence; change "period of 90 days" to "period of 180 days".

**Subsection 627.4.10 Inspection and Acceptance of Work**

Paragraph 2, second sentence; change "90-day observation period" to "180-day observation period".

**Subsection 627.4.10 Inspection and Acceptance of Work**

## SUPPLEMENTAL SPECIFICATIONS

Paragraph 3, first sentence; change "90-day period" to "180-day period".

### DIVISION 700 STRUCTURES

#### SECTION 709 STRUCTURAL STEEL

##### Subsection 709.4.3.5.2 Submittals and Notification

Paragraph 1, delete the last two sentences and replace them with, "The Department's review and acceptance are required before any field welding will be permitted."

##### Subsection 709.6.3 Pay Items (page 650)

Subsection heading number; change subsection heading number from "709.6.3" to "709.6.4".

#### SECTION 712 DRILLED SHAFTS AND DRILLED PILE FOUNDATIONS

##### Subsection 712.4.4 Dry Construction Method

Paragraph 2, last sentence in A; change "*Drilled Shaft Report*" to "*Drilled Shaft Log*".

##### Subsection 712.4.10.4 Excavation Cleanliness

Paragraph 1, last sentence; change "*Drilled Shaft Report*" to "*Drilled Shaft Log*".

##### Subsection 712.4.10.6 Shaft Load Test

Change first paragraph reference number from "2" to "1".

##### Subsection 712.6.10 Drilled Pile Set-Up

Insert paragraph reference number "1" to the left of the first paragraph.

#### SECTION 723 DECK JOINT STRIP SEAL

##### Subsection 723.1 Description

Insert paragraph reference number "3" to the left of the third paragraph.

#### SECTION 726 BRIDGE DECK REHABILITATION

##### Subsection 726.4.1 General

Insert paragraph reference number "1" to the left of the first paragraph.

##### Subsection 723.4.6 Full Depth Patching (page 790)

Subsection heading number; change subsection heading number from "723.4.6" to "726.4.6"

**Subsection 726.6.8 Concrete Overlay (Latex) or (Portland Cement) (page 802)** Paragraph 2, the equation is changed to  $AP=CP \times (ACS/RCS) ^ 2$

#### SECTION 727 CROSSHOLE SONIC LOGGING OF DRILLED SHAFT FOUNDATIONS

##### Subsection 726.6 Payment (page 807)

Subsection heading number; change subsection heading number from "726.6" to "727.6"

### DIVISION 800 INCIDENTAL CONSTRUCTION

#### SECTION 805 GUARDRAIL



**Subsection 805.5 Measurement**

Paragraph 4; amend as follows:

"The quantity for the pay item 8053000 Additional Length Guardrail Post is the length of required post installed in excess of the standard length post based on the system being installed, measured by the linear foot (LF), complete, and accepted."

**SECTION 815 EROSION CONTROL**

**Subsection 815.1 Description**

Paragraph 1, first sentence; change "temporary flexible pipe" to "temporary pipe".

**Subsection 815.5 Measurement**

Paragraph 13; delete the first sentence and replace it with the following sentence:  
"The quantity for Temporary Pipe Slope Drains is measured and paid for in accordance with **Subsections 803.5 and 803.6** respectively."

**Subsection 815.5 Measurement**

Delete paragraph 19.

**Subsection 815.6 Payment**

After paragraph 15, add the following paragraph:

- 16      Payment for Removal of Silt Retained by Silt Fence is full compensation for removing and disposing of sediment deposits accumulated by silt fences as specified or directed and includes all materials, labor, equipment, tools, supplies, transportation, and incidentals necessary to fulfill the requirements of the pay item in accordance with the Plans, the Specifications, and other terms of the Contract.

**Subsection 815.6 Payment**

Change original paragraph number "16" to "17".

**Subsection 815.6 Payment**

Pay Item table; change the Unit for Item No. 8156214 to "EA".

**INDEX:**

Amend as follows:

Page I-3, after "Bridge Deck Rehabilitation, measurement and payment:"

Delete page 807.

Page I-12, after "Letting:"

Replace page 19 with page 9.

Page I-13, after "Overhead Sign Structure:"

Replace page 488 with page 495.

Page I-15, after "Proof Rolling:"

Delete page 98.

Page I-18, after "Structural Steel, turned and ribbed bolts:"

Replace page 624 with page 625.

Page I-19, after "Waterproofing, bridge deck:"

Delete page 907.

Page I-20, after "Working Drawings:"

Replace page 543 with page 779.

## Supplemental Specification

January 1, 2021

APPROVED:

Division Administrator

THADDEUS

W KITOWICZ

Digitally signed by  
THADDEUS W KITOWICZ  
Date: 2020.10.22 14:06:09  
+04'00'

By:

FEDERAL HIGHWAY ADMINISTRATION

### CLAIMS PROCEDURE

#### 1. Scope of Procedure

The following claims procedure covers all claims for additional time or compensation arising under this contract. The claims procedure is non-binding and is a condition precedent to litigation or any other form of dispute resolution. All communications, testimony, and all documents prepared for this procedure by either party from the time of filing the CERTIFICATE OF CLAIM, per section 105.16.8 of the 2007 Standard of Specifications for Highway Construction, to the conclusion of the procedure shall be deemed to be settlement negotiations and not admissible in litigation or any other dispute resolution procedure. If at the conclusion of this procedure the claim has not been resolved, litigation may be pursued through the South Carolina Circuit Court for Richland County. Contractor waives all rights to a jury trial and agrees that all litigation matters shall be heard non-jury and venue for any action shall be in the South Carolina Circuit Court for Richland County.

#### 2. Continuation of Work

At all times during the pendency of a claim under this procedure, the Contractor shall continue work pursuant to the contract and as directed by the Engineer as provided by the contract. If the Contractor fails to continue work, it may be declared delinquent in its work as provided by §108.08 of the South Carolina Standard Specifications for Highway Construction ("Standard Specifications").

#### 3. Submission of Claim

The notice of claim and claim shall be submitted in accordance with §105.16.7 of the Standard Specifications. The notice of claim does not trigger this claims procedure. The claims procedure is initiated when the Contractor submits a written fully detailed CERTIFICATE OF CLAIM to the Resident Construction Engineer ("RCE"). The Contractor must submit three (3) hard copies and one (1) electronic copy of the Claim to the RCE. The claim shall contain, at a minimum, the information required by §105.16.7 of the Standard Specifications. The RCE shall immediately forward a copy of the claim to the District Engineering Administrator ("DEA") for resolution. If the DEA is unable to resolve the claim within thirty (30) days of receipt, the DEA shall forward it immediately to the Director of Construction ("DOC"), together with documents supporting the Department's position. The DEA shall also submit the supporting documents to the Contractor at this time. The DOC shall investigate the claim and attempt to resolve it by mutual agreement with the Contractor. If it cannot be resolved, then the DOC shall make a decision and forward the decision to the Contractor, no later than sixty (60) days after receipt by the DOC. The Contractor shall notify the DOC within thirty (30) days of receipt of the DOC's decision whether the Contractor accepts or rejects the decision.

For all claims under Fifty Thousand Dollars (\$50,000.00) the DOC's decision shall be final and shall conclude the claims procedure. For the purpose of determining if a time only claim may be submitted to the Board, the value of a time only claim shall be deemed to be the number of days requested multiplied by the contract daily rate for liquidated damages. The Contractor does not have a right to submit claims under \$50,000.00 to the Dispute Review Board. If the Contractor does not accept the DOC's decision on its claim of less than \$50,000.00, then its remedy is litigation in the South Carolina Circuit Court for Richland County as set forth in Paragraph 1 of this Claims Procedure or other mutually agreeable dispute resolution procedures.

For all claims in excess of \$50,000.00, if the Contractor rejects the DOC's decision the DOC shall forward the claim to the Dispute Review Board.

#### **4. Dispute Review Board**

A Standing Dispute Review Board has been established and shall be maintained. The Standing Dispute Review Board shall consist of one member selected by the Department, one member selected by the Director of Heavy and Highway Division of the Associated General Contractors (Carolina's Branch), and a third member selected by the first two members. The third member shall be the chairperson of the Standing Dispute Review Board. The selection of qualified Standing Dispute Review Board members shall be made in accordance with the Dispute Review Board rules and procedures (See Section 6.) Each member shall serve a three (3) year term and the terms shall be staggered. Each member is limited to two (2) terms. All board members shall be neutral and unbiased. No party shall have any *ex parte* communication with any Board Member.

#### **5. Hearing Procedure**

The Contractor shall provide an additional three (3) hard copies of its Claim and three (3) portable storage devices (thumb drives) containing its Claim for the DRB's use. The Department shall provide three (3) hard copies and three (3) portable storage devices (thumb drives) containing its response to the Claim for the DRB's use. The DOC shall send both the Contractor's Claim and the Department's response to the Claim to the DRB within 45 days of the Contractor's rejection of the DOC decision.

Within fifteen (15) days of notice of submission of the claim to the Board, the Contractor may submit to the DOC five (5) written and electronic copies of any additional documentation supporting its claim. The DOC shall immediately forward three (3) copies to the Board, one (1) copy to the DEA, and the DOC will keep one (1) copy.

Within fifteen (15) days of receipt of the Contractor's supplemental documentation, the DEA may submit to the DOC five (5) written and electronic copies of its additional documentation. The DOC shall immediately submit three (3) copies to the Dispute Review Board, one (1) copy to the Contractor, and the DOC will keep one (1) copy.

The Dispute Review Board shall review all documents and notify the parties of what additional documents, if any, it requires. The Dispute Review Board shall schedule a hearing at either party's request or may schedule a hearing at its own discretion. However, if a hearing is requested, it must be held no later than sixty (60) days after the DOC submits the claim to the Dispute Review Board. The location of the hearings shall be determined by the Board. While extensions of these deadlines are discouraged, the Dispute Review Board shall have authority to extend any of the above deadlines for just cause.

The Dispute Review Board shall have full authority to establish guidelines and procedures for the investigation of a claim. The entire process is intended to be flexible and the Board is encouraged to adapt the process to individual circumstances presented by particular disputes.

In the interest of timely resolution of all claims, the Board shall conduct all hearings and issue its final decision within ninety (90) days of receipt of the claim.

The Dispute Review Board Chairperson shall direct all meetings and hearings. Presentation of evidence shall be in accordance with the Dispute Review Board's rules and shall not be bound by judicial rules of evidence. Documents and testimony shall be presented in the order, manner and degree of detail that the Dispute Review Board deems most efficient and probative. Each party shall be allowed to make a brief initial presentation and to rebut any factual assertion by another party; however, the Dispute Review Board shall determine when enough evidence has been presented and it may limit the presentation of any

documentation or testimony that it deems not relevant or redundant. At the Board's option, testimony may be required to be given under oath and the oath shall be administered by the Chairperson.

Legal counsel for either party may be present at meetings or hearings as observers only. If a party intends to have its counsel present at a hearing, it must provide at least ten (10) days' notice prior to the meeting or hearing. Legal counsel may not speak on behalf of a party, unless requested by the Board. Counsel may not examine or cross-examine witnesses, object to questions or statements during meetings or make legal motions or arguments during meetings or hearings. The Board, by majority vote, may suspend legal counsel's privilege to attend meetings or hearings.

The Dispute Review Board shall issue to the Contractor and the Director of Construction a written recommendation with an explanation of the results as soon as reasonably possible following the conclusion of the hearing. However, in no event shall the Board take more than ninety (90) days from receipt of claim to conduct hearings and issue a recommendation. The Board is encouraged to reach a unanimous decision; however, it may provide a majority recommendation. The minority Board Member may provide a written explanation of his position. The Board shall provide further explanation of its decision if requested by either party within ten (10) days of the receipt of the decision. Issuance of the Board's recommendation concludes the claims procedure.

The parties may settle at any time during the procedure. If the dispute is resolved prior to issuance of a recommendation, the DOC shall immediately notify the Board.

Within sixty (60) calendar days of issuance of the Board's recommendation each party shall notify the other in writing whether or not they accept the Board's decision.

If at the conclusion of this procedure the claim has not been resolved, litigation may be pursued in South Carolina Circuit Court for Richland County as set forth in Paragraph 1 of this Claims Procedure.

The Board members shall not be compelled to testify, give any type of statements, nor produce any documents or evidence submitted at the DRB hearing in any subsequent proceedings or litigation.

## **6. Dispute Review Board Rules and Procedures**

### **a. Qualifications of Dispute Review Board Members**

- (1) All Dispute Review Board Members shall have substantial experience in highway or bridge design and construction. This experience may be technical, administrative or legal. The goal is to have a Board with the technical and administrative skills and experience that will promote confidence in its decisions.
- (2) No Dispute Review Board Member shall be employed currently or within the last three (3) years with the Department, any Contractor (currently or in the past pre-qualified with the Department), or any design consultant that has worked for the Department within the last three (3) years.
- (3) No Dispute Review Board Member shall have any financial or ownership interest in any party to the contract nor any design consultant or major subcontractor.

### **b. Selection of Dispute Review Board Members**

The selection process for Dispute Review Board Members shall begin at the appropriate time in order to allow completion of the Member selection by beginning of the term. The selection process shall be as provided in Section 4.

### **c. Replacement of Board Members**

Each party may elect to replace its Board Member at any time with a showing of reasonable justification. The Chairperson of the Board may be replaced at any time with the consent of both parties. If any Board Member is replaced, the new member shall be selected in the same manner in which the original appointment had been made.

If disputes are pending at the end of a member's term, the existing Board shall complete its hearing on the disputes and issue a decision.

d. Costs

Board Members shall be paid a reasonable hourly rate or salary for their services. Each party shall negotiate the fee arrangements with the Member it selects, however, the other party must agree on the rate. Both parties shall agree on the fee arrangement for the Chairperson.

Board Members shall be reimbursed for out-of-pocket expenses including, but not limited to, travel, copying, telephone, clerical services, and mailings. The Board Members shall be allowed reimbursement of actual expenses for meals up to the daily maximums set forth in the Department's Regulations for Reimbursement of Travel and Subsistence Expenses and actual lodging costs provided they stay in hotels approved by the Department and they obtain a government rate. Board Members must provide documentation for all expenses.

The parties shall share all Board Members' fees and expenses equally. The total fees and expenses to hear each claim shall not exceed the following maximum amounts unless otherwise agreed to by both parties in writing (one claim shall constitute all issues submitted to the Dispute Review Board at one (1) time):

<u>Claim Amount</u>	<u>Cumulative Total</u>
\$ 50,000 - \$499,999.99.....	\$15,000.00
\$500,000.00 - \$999,999.99.....	\$25,000.00
\$1 million - \$4,999,999.99.....	\$40,000.00
over \$5 million.....	\$75,000.00

The Department shall pay the Board Members and deduct the Contractor's share from monies owed to the Contractor. If monies owed are not sufficient, the Contractor shall pay the Department directly for its share of the fees and expenses.

July 2017

## PROMPT PAYMENT CLAUSE

(1) Subject to the provisions on retainage provided in Paragraph (2) below, when a subcontractor has satisfactorily performed a work item of the subcontract, the Contractor must pay the subcontractor for the work item within seven (7) calendar days of the Contractor's receipt of payment from SCDOT. A subcontractor shall be considered to have "satisfactorily performed a work item of the subcontract" when the SCDOT pays the Contractor for that work item. In the case of a second or third tier subcontractor, the 7-day time period begins to run when the 1st tier subcontractor receives payment from the Contractor or when the 2nd tier subcontractor receives payment from the 1st tier subcontractor.

(2) The Contractor may withhold as retainage up to five (5%) percent of a subcontractor's payment until satisfactory completion of all work items of the subcontract. "Satisfactory completion of all work items of the subcontract" shall mean when the SCDOT accepts the last work item of the subcontract. The Contractor must release to the subcontractor any retainage withheld within seven (7) calendar days from the date the Contractor receives payment from SCDOT for the last work item of the subcontract or within seven (7) days from SCDOT's acceptance of the last work item of the subcontract, whichever is the latest to occur. However, upon documentation of good cause provided by the contractor and written concurrence by the Director of Construction, the Contractor may continue to withhold the 5% retainage.

(3) Prior to receiving payment of each monthly estimate, the Contractor shall (a) certify to SCDOT that the construction estimate is complete and that its subcontractors have been paid for work covered by previous estimates, for which they are entitled to be paid, in accordance with paragraphs (1) and (2) above, and (b) submit verification that Contractor has received similar certifications or evidence from its subcontractors that lower tier subcontractors have been paid in accordance with paragraph (1). No payment will be made to Contractor unless such documentation/certification is received or SCDOT has issued written approval for delayed payment and required status reports as follows:

(i) The obligation to promptly pay subcontractors (all tiers) or to release retainage does not arise if there is a legitimate subcontract dispute with first tier and/or lower tier subcontractors. If there is a subcontract dispute, the Contractor may submit a written request to SCDOT to approve a delay in payment to the subcontractor which shall explain the nature of the dispute and identify relevant subcontract provisions as support. The explanation may include those reasons set forth in the SC Prompt Pay Act (S.C. Code Section 29-6-40). Payment to the subcontractor shall not be withheld without prior SCDOT written approval.

(ii) Contractor shall submit a status report of the dispute in each monthly progress payment. The status report shall contain:

- justification for the continuation of nonpayment in the form of a pending judicial proceedings, alternate dispute resolution (ADR) process or administrative proceedings, as evidence of why the delay shall continue; or

- a certification that the matter is resolved and payment has been issued to the subcontractor (first tier and/or lower tier subcontractors).

(4) Failure to comply with any of the above provisions shall constitute a material breach of the contract and shall result in one or more of the following sanctions: (1) no further payments to the Contractor unless and until compliance is achieved; (2) monetary sanctions; and/or (3) the Contractor being declared in default and being subject to termination pursuant to Section 108.10 of the Standard Specifications.

(5) Any subcontractor who believes it is due payment in accordance with the Prompt Payment Clause may request information from the servicing Resident Construction Engineer (RCE) as to whether and when payment for the subcontractor's work has been made to the Contractor. If payment has been made to the Contractor, and a subcontractor certifies to the RCE that the subcontractor has not been paid within seven (7) calendar days of SCDOT's payment to the Contractor or paid as provided in paragraph (1) for sub-tiers, the RCE will notify the Director of Construction. If SCDOT has not approved the delay in payment pursuant to paragraph 3 above, appropriate remedies set forth in paragraph (4) will be applied. On federally funded projects, the subcontractor may contact the Federal Highway Administration should SCDOT fail to address the non-payment issue.

(6) The Contractor agrees by submitting this bid or proposal that it will include this clause titled "PROMPT PAYMENT CLAUSE," provided by the SCDOT, without modification, in all subcontracts with its subcontractors. Contractor is responsible for requiring all of its subcontractors to include this PROMPT PAYMENT CLAUSE in all lower tier subcontracts. If Contractor knowingly enters or knowingly allows a subcontractor or lower tier subcontractor to enter into a subcontract without the PROMPT PAYMENT CLAUSE, SCDOT may apply the appropriate remedies set forth in paragraph (4) or pursue other available remedies, including breach of contract.

July 01, 2019

**Sloped Edge Longitudinal Shoulder Joints**

**Add the following to Subsection 401.4.23 of the Standard Specifications:**

All surface mixtures placed at 150 lbs. per square yard or greater will require the sloped edge joint device. The device contacts the surface of the shoulder of the road and creates an improved transition to cross roads, driveways and obstructions. The device may be removed if deemed necessary for projects that do not require or need a sloped edge profile.

Use a sloped edge longitudinal shoulder joint attachment for the asphalt paver in order to create a sloped edge profile onto an existing roadway shoulder. Construct a sloped edge onto the longitudinal shoulder joint to promote a safe transition between the newly placed asphalt mixture and the existing shoulder (without curb or other confined edges) using an approved device.

Approved devices are listed on Qualified Product Listing No. 75. These devices must meet the requirements of this specification and Qualified Product Policy No 75 to be included on QPL 75. The sloped edge device will be designed to be attached to the paver that confines the material at the end gate and extrudes the asphalt material in such a way that results in a consolidated wedge shape pavement edge of between 25-35 degrees. The device must be designed to constrain the asphalt material by reducing the area by 10 to 15% thereby increasing the consolidation of the extruded profile. The use of a conventional single plate strike off is not permitted.

**APPROVED:**  
Division Administrator  
  
**By:** \_\_\_\_\_  
FEDERAL HIGHWAY ADMINISTRATION



July 1, 2010

**Subsection 401.4.17, Transportation and Delivery of Mixes, of the Standard Specification will be deleted in its entirety and replaced with the following:**

Transport the HMA from the plant to the point of use in vehicles meeting the requirements of Subsection 401.3.7. Do not permit any load of HMA to leave the plant so late in the day that it cannot be spread, finished, and compacted during daylight of that same day unless an approved artificial lighting system is provided. Ensure that HMA mixtures containing the asphalt binder grades below are produced and delivered to the jobsite within the acceptance range listed in the table below with exception that Base C and D mixtures will be produced and delivered at a temperature range of 240°-275° F. The mix temperatures will be checked using SC-T-84. Ensure the HMA mixtures are held within the acceptance range based on Binder Performance Grade in the Job Mix Formula. Deliver mixture within the acceptance range for temperature to assist in obtaining density requirements which provide smooth riding pavements with uniform texture.

<b>Binder Performance Grade</b>	<b>Acceptance Range (°F)</b>
PG 64-22	265°-325°
PG 70-22	285°-335°
PG 76-22	300°-350°

Note: This temperature specification does not apply to WMA (SC-M-408). Refer to the HMA Contractor's QC Plan for mix acceptance range based on selected asphalt plant WMA technologies.

# Supplemental Technical Specification for Cement Modified Recycled Base

SCDOT Designation: SC-M-306 (07/21)

APPROVED:

Division Administrator

THADDEUS  
W KITOWICZ

Digitally signed by  
THADDEUS W KITOWICZ  
Date: 2021.08.10 10:49:32  
-04'00'

By: \_\_\_\_\_

FEDERAL HIGHWAY ADMINISTRATION

## 1.0 DESCRIPTION

- 1.1 This section contains specifications for the materials, equipment, construction, measurement, and payment for the modification of an existing paved roadway or shoulder by scarifying the existing pavement structure, mixing it with Portland cement, and constructing the base course in conformance with the lines, grades, dimensions, and cross-sections shown on the Plans or as directed by the **RCE**.

## 2.0 MATERIALS

- 2.1 Portland Cement - Use Portland cement that conforms to the requirements of **Subsection 301.2.1**.
- 2.2 Water - Use water conforming to the requirements of **Subsection 701.2.11**.
- 2.3 Asphalt Material – Use asphalt material conforming to the requirements of **Subsection 301.2.4**.

## 3.0 EQUIPMENT

- 3.1 Ensure that the equipment necessary for the proper construction of the work is on site and in acceptable working condition. Provide sufficient equipment to enable prosecution of the work in accordance with the project schedule and completion of the work in the specified time.
- 3.2 Construct the base with self-propelled rotary mixer(s)/reclaimer(s) capable of mixing in place to the required depth. The mixer(s)/reclaimer(s) shall have a mechanism for controlling the reclaimed material gradation via breaker bar and/or a door opening on the mixer(s)/reclaimer(s). Mixer(s)/reclaimer(s) shall be fitted with an integrated liquid injection system capable of introducing liquid into the cutting drum during the mixing process.
- 3.3 Provide a sufficient number of water trucks on the jobsite at all times of operation to maintain the moisture requirements listed in **Subsection 9**. Ensure that the water truck used in conjunction with the reclaimer uses a direct injection system, and additional trucks maintain surface moisture during grading and compaction work and until the curing treatment is applied in accordance with **Subsection 13**. Accomplish this using a controlled and uniform application of water without eroding or otherwise damaging the CMRB surface.
- 3.4 Provide a spreader/distributor capable of achieving consistent, accurate and uniform distribution across the entire length and width of the roadway while minimizing dust. Ensure that the spreader has adjustable openings or gate headers and is not solely dependent on vehicle speed to obtain the required spread rate.
- 3.5 Provide a combination of sheepfoot rollers, smooth wheel tandem rollers, and/or pneumatic-tired rollers that have the ability to adequately compact reclaimed material throughout the entire specified CMRB thickness. Ensure the necessary weight, size and number of rollers to achieve the requirements of **Subsection 10**.

## 4.0 CONSTRUCTION

- 4.1 Regulate the sequence of work to process the necessary quantity of material to provide the full depth of modification as shown on the Plans:
  - 4.1.1 Ensure structural integrity of reclaimed material is consistent throughout the depth of the modification.
  - 4.1.2 Ensure surface quality is sufficient to provide durable temporary pavement structure surface and supports permanent pavement structure performance.
  - 4.1.3 Incorporate appropriate material as specified in the plans for drainage correction, cross slope correction or roadway strengthening.

## 5.0 QUALITY CONTROL PLAN, TEST STRIP & CORRECTIVE ACTION REQUIREMENTS

- 5.1 Prepare an annual Quality Control Plan that ensures that operational techniques and activities provide integral and finished material of acceptable quality for each Cement Modified Recycled Base project. Submit a Quality Control Plan for acceptance to the Chemical Stabilization Engineer (CSE) in writing a minimum of two weeks before work begins for the year.
- 5.2 The Quality Control Plan should include, but not be limited to addressing the following items:
  - 5.2.1 Contingency plans for pulverization, mixing and compaction when specifications criteria are not met. Consider the specific roadway conditions of various project sites.
  - 5.2.2 Plan for identifying in-situ moisture conditions, adjusting the moisture content to meet specifications, and maintaining moisture content through the time of curing. Include a description of the methods and minimum contractor testing for moisture. Consider specific environmental conditions of various project sites and schedules.
- 5.3 Test Strips
  - 5.3.1 The first load of cement on the roadway will be used as a test strip to determine if the contractor is capable of producing a mixture according to specifications. Particular attention will be paid to the moisture and compaction requirements set in **Subsection 10**, mixing and processing requirements set in **Subsection 9**, pulverization requirements set in **Subsection 7**, depth requirements in **Subsection 17**, and cement tolerances in **Subsection 8**. Cease production after the first load if any of the requirements of the specification are outside of the tolerances and change procedures to contingency plans approved in the QC Plan to continue work. Continue production as normal on the same day when the test strip meets the specification requirements.
  - 5.3.2 The first load applied with the contingency plans will be used as a test strip to evaluate the corrective action plan. Cease production after this initial load of cement if the requirements of this specification are still not being met and submit a revised corrective action plan to the **RCE** for acceptance prior to continuing work.
  - 5.3.3 If the requirements of this specification are not being met in a section not defined as a test strip (a section is defined as one load of cement) then one additional load of cement will be allowed. Cease production after this additional load of cement if the requirements are still not being met and submit a corrective action plan to the **RCE** for acceptance prior to continuing work.

## 6.0 SHOULDERS & ROADWAY PREPARATION

- 6.1 Remove all excess vegetation generated from the clipping and cleaning of shoulders from the roadway and any other debris, including Reflective Pavement Markers, prior to performing the mixing operations. Remove material from the shoulders as necessary to ensure proper drainage at all times.

## 7.0 PULVERIZATION

- 7.1 Provide means, methods, and equipment necessary to obtain satisfactory pulverization of the pavement so that at the completion of pulverization and mixing (prior to compactive efforts), a uniform mixture is created in which 100% of the reclaimed material mixture (by weight) passes a 3 inch sieve and 95% of the reclaimed material mixture (by weight) passes a 2 inch sieve. When necessary, SC-T-1 Section 6.6 will be used for sampling to run gradation tests. Rework areas not meeting this gradation control measure as necessary, adhering to the time limitations in **Subsection 11**. The pulverization pass is defined as at least one pass of the mixer prior to the application of cement. Additional passes are allowed. Lightly compact following each pass of the mixer to produce a uniform layer. Carefully control the depth of pulverization and conduct operations in a manner to ensure that the surface of the roadbed below the pulverized material remains undisturbed and conforms to the required cross-section. Means, methods and equipment including but not limited to additional passes of the reclaimer, milling in place or the use of supplementary equipment to achieve pulverization is the responsibility of the contractor and incidental to the process.
- 7.2 If the requirements of pulverization are not being met in a section not defined as a test strip (a section is defined as one load of cement) then one additional load of cement will be allowed. Cease production after this additional load of cement if the requirements are still not being met and submit a corrective action plan to the **RCE** for acceptance prior to continuing work.

## 8.0 APPLICATION OF CEMENT

- 8.1 The **CSE** will determine the rate of cement based on test results supplied in writing by the Contractor. Do not commence construction until an approved rate has been determined by the **CSE**. Allow two weeks from the date of submittal for the results and selection of appropriate cement rate. The test results will be conducted according to SC-T-26 by an AASHTO-accredited laboratory with material obtained from the roadway in which construction is to occur. Ensure that the roadway sampling and mix design testing is representative of the entire area and depth to be treated, several samples and/or designs may be necessary.
- 8.2 Spread Portland Cement uniformly on the pulverized material at the rate established by the **CSE**, taking care to minimize fugitive dust and minimize overlapping of the passes (maximum 6 inches). Apply cement only when the temperature is 40°F in the shade and rising, and no freezing temperatures are predicted for at least 48 hours. Do not perform work on frozen or excessively wet subgrade. A tolerance of 5% (of the rate) is allowed in the spread rate for individual sections (load of cement) of roadway; however, adjustments should be made in order to keep the actual spread rate as close to that established by the **CSE**. Only apply cement to such an area that all the operations (including final compaction) can be continuous and completed in daylight, unless adequate artificial light is provided. Ensure that all operations (including final compaction) can be completed within 3 hours of application of cement.

- 8.3 Do not allow the percentage of moisture in the reclaimed material mixture at the time of cement application to exceed the quantity that permits uniform and thorough mixture of reclaimed material or that creates instability of the roadway. Do not allow equipment, except that used in spreading and mixing, to pass over the freshly spread cement until it is mixed with the reclaimed material mixture.
- 8.4 If the requirements of cement application are not being met in a section not defined as a test strip (a section is defined as one load of cement) then one additional load of cement will be allowed. Cease production after this additional load of cement if the requirements are still not being met and submit a corrective action plan to the RCE for acceptance prior to continuing work.

## 9.0 MIXING & PROCESSING

- 9.1 Pulverize material as necessary to meet the requirements given in **Subsection 7**. The pulverization pass is defined as at least one pass of the mixer prior to the application of cement. Lightly compact following each pass of the mixer to produce a uniform layer.
- 9.2 After the cement has been applied per **Subsection 8**, mix and uniformly add necessary moisture to the reclaimed material to ensure that the moisture content is above the optimum value as set in the approved mix design and within +/- 2% of the optimum moisture content when tested within 30 minutes of final compaction. Mix with at least one pass of the reclaimer after cement application at minimum. Additional passes are allowed, adhering to time limitations set forth within this specification. Ensure full width pulverizing and mixing by overlapping a minimum of 6 inches with each longitudinal pass, including at the longitudinal joint of each lane, and a minimum of 2 feet with each transverse joint. Additional mixing passes may be required in the contract documents. Lightly compact following each pass of the mixer to produce a uniform layer.
- 9.3 Immediately begin final compaction after the mixing process has been completed so that the requirements of **Subsection 10** are met.
- 9.4 Remove excess material generated from the mixing process after final grading operations have been completed.
- 9.5 If the requirements of mixing and processing are not being met in a section not defined as a test strip (a section is defined as one load of cement) then one additional load of cement will be allowed. Cease production after this additional load of cement if the requirements are still not being met and submit a corrective action plan to the RCE for acceptance prior to continuing work.

## 10.0 COMPACTION

- 10.1 Before beginning compaction, ensure that the mixture is free from excessive fluff and overly compacted areas to allow for uniform compaction of the layer. Continue compaction until the entire depth of the base course mixture is uniformly compacted to not less than 95% of the maximum density. SC-T-23, SC-T-26, SC-T-27, or SC-T-29 will be used at the discretion of the RCE to determine the maximum density of the composite mix. If tests show that 95.0% requirement is not being met, adjust construction operations to obtain the required density. Complete the compaction work within 1 hour of the final mixing pass.
- 10.2 After the mixture is compacted, reshape the surface of the base course as necessary to conform to the required lines, grades, and cross-section. Perform light scarifying to a depth which removes the sheepfoot imprints at minimum. Continue as required to obtain a uniform surface and to prevent scaling and delamination.

- 10.3 Perform compacting and finishing in a manner that produces a smooth, closely knit surface, free from equipment imprints, cracks, ridges, or loose material. Maintain the moisture content of the mixture within +/- 2% of the optimum moisture as determined by the pre-approved mix design and keep the surface continuously moist to the time of final curing coat being applied. The moisture content and density requirements for compaction will be tested for acceptance within 30 minutes of final compaction. Additional moisture contents tests will be randomly performed for acceptance through the curing application to ensure that the surface moisture is maintained above optimum moisture.
- 10.4 If the requirements of compaction are not being met in a section not defined as a test strip (a section is defined as one load of cement) then one additional load of cement will be allowed. Cease production after this additional load of cement if the requirements are still not being met and submit a corrective action plan to the **RCE** for acceptance prior to continuing work.

## 11.0 CONSTRUCTION LIMITATIONS

- 11.1 Perform work in daylight hours unless adequate artificial light is provided. Limit the area over which the cement-pavement mixture is spread so that all operations specified in **Subsections 7, 8, 9, 10 and 13** are performed continuously until completion of a section (load of cement). Complete all grading and compaction work on a section (load of cement) within 2 hours after the initial mixing pass of the reclaimer unless the **RCE** approves a longer period.
- 11.2 If operations are interrupted for a continuous period of greater than 1 hour after the cement has been mixed with the reclaimed material, reconstruct the entire affected section (area of interruption) in accordance with these specifications. When the uncompacted reclaimed material mixture and cement is wetted so that the moisture content exceeds that specified, manipulate and aerate the mixture to reduce the moisture to the specified content provided the base course is completed within the time limits of these specifications.
- 11.3 Begin subsequent lifts of asphalt or chip seals which cover the Cement Modified Recycled Base curing methods and act as a final riding surface within 7 calendar days of completion of the CMRB section unless the **RCE** approves a longer period. Begin these subsequent lifts so that no more than 4 miles have temporary surface treatment on them at any time. A section is defined as the contract section of roadway receiving CMRB treatment. When using Curing Methods B or C, ensure that a milled surface is not left open to the public for more than 72 hours.

## 12.0 WEATHER LIMITATIONS

- 12.1 Apply cement only when the temperature is 40°F in the shade and rising, and no freezing temperatures are predicted for at least 48 hours. Do not perform work on frozen or excessively wet subgrade. The temperature restrictions for single treatment, when used as a curing option, shall meet the requirements of this reclamation specification. If the successive course is a final riding course, the seasonal restrictions of December, January and February apply unless otherwise approved by the **DOC**.

## 13.0 CURING

- 13.1 After the Cement Modified Recycled Base has been finished as specified, cure the surface using the specified method in the plans or contract. Dampen and sweep the CMRB immediately prior to the application of the surface treatment.

*Curing Method A: Surface (Single) Treatment*

*Curing Method B: Surface (Single) Treatment with Milling*

*Curing Method C: Surface (Double) Treatment with Milling*

- 13.2** After the Cement Modified Recycled Base has been finished as specified, protect the base from rapid drying and traffic by placing Asphalt Surface Treatment as specified in **Section 406 or 407**, with the exception that lightweight aggregate is not required and CRS-2 may be used in place of CRS-2P. Perform this operation daily to protect the newly constructed Cement Modified Recycled Base, unless otherwise directed by the **RCE**.
- 13.3** Prior to placement of the HMA course in Methods B & C, mill the Cement Modified Recycled Base course surface to obtain a true and level finish for the asphalt placement. Ensure that a diamond milling pattern with a double or triple strike is clearly visible in the finished surface. Consider the final thickness during construction, leaving the specified depth of treatment after the milling has occurred. Ensure that the surface is left in a condition ready for paving, free from scabbing, scaling and other defects. Ensure that any structure lost to additional, deeper milling to remove these defects is replaced with asphalt. Include this cost in the Cement Modified Recycled Base price.

#### **14.0 CONSTRUCTION JOINTS**

- 14.1** At the end of each day's construction, form a straight construction joint as specified in **Subsection 301.4.9**.

#### **15.0 SURFACE SMOOTHNESS**

- 15.1** Ensure that the finished surface of the recycled base meets the requirements of **Subsection 301.4.10**. The grade of the road will be based on existing conditions of the roadway. Grade the cross slope to obtain positive drainage as well as smooth transitions from crown to superelevated sections of the roadway, re-grade roads with a pre-existing cross slope of 2% or greater to the same cross slope. On roads with a pre-existing cross slope of less than 2%, the Contractor and **RCE** will determine the measures required to obtain positive drainage and the final crossslope.

#### **16.0 RIDEABILITY**

- 16.1** Ensure that the final asphalt surface placed on Cement Modified Recycled Base course meets the Rideability requirements of SC-M-403 for either New Construction or Resurfacing, whichever is applicable based on the specified pavement structure.

#### **17.0 THICKNESS TOLERANCE**

- 17.1** The thickness of the completed Cement Modified Recycled Base will be measured at random intervals not to exceed 1,000 feet in length. The average job thickness will be measured daily using the average value of all measurements taken by the inspector each day. Where the measured thickness is more than 1 inch greater than the specified thickness, the thickness of that location will be considered the specified thickness plus 1 inch. If the average job thickness varies from the specified job thickness by more than ½ inch, an adjusted unit price is used for calculating payment. The pay factor will be calculated as below and applied;

$$\text{Pay Factor} = 1 - \frac{|\text{Average Job Thickness} - \text{Specified Job Thickness}|}{\text{Specified Job Thickness}}$$

$$\text{Adjusted Contract Unit Price} = \text{Pay Factor} \cdot \text{Contract Unit Price}$$

**17.2** If the requirements of thickness (any single test value greater than 1 inch different from the specified depth) are not being met in a section not defined as a test strip (a section is defined as one load of cement) then one additional load of cement will be allowed. Cease production after this additional load of cement if the requirements are still not being met and submit a corrective action plan to the RCE for acceptance prior to continuing work.

## **18.0 OPENING TO TRAFFIC**

**18.1** Local traffic may use completed portions of the Cement Modified Recycled Base provided the base has hardened sufficiently to prevent marring, damaging or visible rutting of the surface by such usage. Ensure that no damage occurs to the curing coat. With approval of the District Office, temporary detours may be utilized during the reclamation process to reduce the traffic on the reclaimed roadway. Use the subgrade shoulders or completed pavement, when available, for transporting materials, workers, and equipment throughout the project. Do not place construction equipment on the base without the approval of the RCE unless it is being used in the subsequent construction operation.

## **19.0 MAINTENANCE**

**19.1** Maintain the Cement Modified Recycled Base in accordance with **Subsection 301.4.13**.

## **20.0 MEASUREMENT**

**20.1** The quantity for the pay item Cement Modified Recycled Base (of the uniform thickness required) is the surface area of a uniform base constructed by applying and mixing cement with the subgrade as specified and is measured by the square yard (SY) of the modified base in-place, complete and accepted. Cement Modified Recycled Base constructed outside the designated area is not measured for payment.

**20.2** The quantity for the pay item Portland Cement for Cement Modified Recycled Base is the weight of cement incorporated into the base at the rate established by the CSE and is measured by the ton (TON), complete and accepted. Portland cement incorporated in excess of 5% of the amount established by the CSE is not included in the measurement. Furnish the RCE with invoices of all cement received to verify weight.

## **21.0 PAYMENT**

**21.1** Payment for the accepted quantity of Cement Modified Recycled Base (of the uniform required thickness) or Portland Cement for Cement Modified Recycled Base, measured in accordance with **Subsection 20** is determined using the contract unit bid price for the applicable item.

**21.2** Payment for Cement Modified Recycled Base (of the uniform required thickness) is full compensation for constructing the Cement Modified Recycled Base course as specified or directed and includes pulverizing and scarifying the existing pavement,



applying and spreading cement, processing and mixing base course material, watering and maintaining proper moisture content, compacting, finishing, curing, hauling and disposing of excess shoulder material and curing base course, forming construction joints, and all other materials, labor, equipment, tools, transportation, and incidentals necessary to complete the work in accordance with the Plans, the Specifications, and other terms of the Contract.

- 21.3** Base course that is deficient in thickness is paid for at the adjusted unit price specified in **Subsection 20**.
- 21.4** Payment for Portland Cement for Cement Modified Recycled Base is full compensation for furnishing and weighing the cement as specified or directed and includes all other materials, labor, equipment, tools, supplies, transportation, and incidentals necessary to complete the work in accordance with the Plans, the Specifications, and other terms of the Contract.
- 21.5** Payment for excess reclaimed material generated from the roadway (excluding shoulder material) is paid for as unclassified excavation.
- 21.6** Payment for each item includes all direct and indirect costs or expenses required to complete the work.
- 21.7** Pay items under this section include the following:

<b>Item No.</b>	<b>Pay Item</b>	<b>Unit</b>
3063306	Cement Modified Recycled Base (6" Uniform)	SY
3063308	Cement Modified Recycled Base (8" Uniform)	SY
3063310	Cement Modified Recycled Base (10" Uniform)	SY
3063312	Cement Modified Recycled Base (12" Uniform)	SY
3064000	Portland Cement for Cement Modified Recycled Base	TON

January 1, 2020

**SECTION 810: EROSION CONTROL MEASURES****APPROVED:**

Division Administrator

By: 

FEDERAL HIGHWAY ADMINISTRATION

In addition to the erosion control measures specified in the Plans, Standard Specifications, Supplemental Technical Specifications and the Special Provisions, the Contractor is advised that all land disturbing activities (clearing and grubbing, excavation, borrow and fill) are subject to the requirements set forth in the following permits and regulations:

- South Carolina Code of Regulations 63-380, Standard Plan for Erosion, Sediment, and Stormwater Runoff Control. The regulation can be found at the South Carolina Legislature website.
- Erosion and Sediment Reduction Act of 1983 (Title 48, Chapter 18 of the South Carolina Code of Laws of 1983, as amended). Section 70 of this code authorized the South Carolina Department of Health and Environmental Control (SCDHEC) to administer this regulation with respect to lands under the jurisdiction of the South Carolina Department of Transportation. The code can be found at the South Carolina Legislature website.
- National Pollutant Discharge Elimination System (NPDES) General Permit Number SCR160000, effective January 1, 2013 (or latest version): The Environmental Protection Agency, in accordance with the Federal Clean Water Act, has granted to the South Carolina Department of Health and Environmental Control (SCDHEC) the authority to administer the Federal NPDES permit program in the State of South Carolina. The permit may be viewed at the SCDOT website.

In accordance with the NPDES General Permit SCR160000 section 2.1.E: "The Prime Contractor hired by SCDOT for a project will become a Secondary Operator with SCDOT upon signing the awarded contract. The Secondary Operator must complete the agreement found in Appendix B of the SCDOT Contract, (Contractor Certification Form). The agreement is to be signed in accordance with the signatory requirements of §122.22 of the South Carolina Regulation 61-9. The agreement is to be maintained with the SWPPP.

By signing the Contract, the contractor accepts/understands the terms and conditions of the *Storm Water Pollution Prevention Plan (SWPPP)* as required by the NPDES General Permit SCR160000 and may be legally accountable to SCDHEC for compliance with the terms and conditions of the SWPPP. In addition the contractor is responsible for ensuring all subcontractors comply with the SWPPP and the permit requirements.

The SCDOT will complete and forward a *Notice of Intent (NOI)* to SCDHEC. If SCDHEC does not send a letter within 10 business days of receipt of the *NOI*, authorizing coverage, denying coverage, or advising that a review of the *SWPPP* will take place, coverage will be automatically granted.

At the pre-construction conference, with the contractor, the SWPPP will be explained and discussed so that the contractor is made aware of their responsibilities in the SWPPP.

Upon authorization of coverage, the SWPPP is to be fully implemented. The prompt installation of erosion control devices should be coordinated with construction activities to maintain compliance with the above regulations and NPDES General Permit.

---

SUPPLEMENTAL SPECIFICATION

---

Erosion and Sediment Control Inspections are to be conducted by a qualified individual (Certified Erosion Prevention and Sediment Control Inspectors (CEPSCI), P.E., or those as stated in the permit) by the Department at least every 7-calendar days. A representative of the Contractor is also encouraged to accompany the inspection. Correct deficiencies noted during these inspections within the assigned priority period. If deficiencies are not corrected within this timeframe, the RCE can stop all work (except erosion and sediment control measures) until the deficiencies are corrected.

Give special attention to critical areas within the project limits (i.e., running streams, water bodies, wetlands, etc.). In these areas, the RCE may direct the Contractor to undertake immediate corrective action, but in no case allow these deficiencies to remain unresolved more than 48 hours for a priority 1 deficiency or 7 days for a priority 2 deficiency. This is in accordance with their assigned priority as identified during the Erosion and Sediment Control Inspection.

Failure to adequately comply with the provisions as detailed above or any other required erosion control measures can result in stoppage of all contract operations (except erosion and sediment control measures) until corrective action has been taken. Additional sanctions may be invoked by the SCDHEC in accordance with their authority.

Fines assessed on the Department by SCDHEC as the result of the Contractor's non-compliance or violation of said permit provisions will be paid by the Department and will subsequently be deducted from any monies due or that may become due to the Contractor. In case no monies are due or available, the fines incurred will be charged against the Contractor's Surety.

SUPPLEMENTAL SPECIFICATION

APPROVED:  
Division Administrator

THADDEUS Digitally signed by THADDEUS W KITOWICZ

By: W KITOWICZ 2020.05.28 16:27:32  
FEDERAL HIGHWAY ADMINISTRATION

July 1, 2020

WORK ZONE TRAFFIC CONTROL  
TRAINING REQUIREMENTS  
FOR  
CONTRACTORS / SUBCONTRACTORS

**1. Description:**

This specification details the work zone traffic control training requirements for employees and representatives of a contractor or subcontractor under contract to the South Carolina Department of Transportation (SCDOT) whose job duties include responsibilities relative to implementation and maintenance of the Transportation Management Plan (TMP). "Employees and representatives of a contractor or subcontractor" will henceforth be referred to as "employee" or "employees" and "contractor or subcontractor" will henceforth be referred to as "contractor".

The SCDOT requires the contractor to provide documentation to substantiate successful completion and attainment of a passing score of a prescribed training course conducted by an SCDOT approved provider by those employees whose job duties categorize them as "designated trainees" as defined hereinafter.

**2. Implementation:**

These requirements for work zone traffic control training for employees of those entities under contract to the SCDOT whose job duties include responsibilities relative to implementation and maintenance of a TMP shall become effective on all projects let to contract after September 1, 2013.

**3. Designated Trainees:**

An employee whose job duty responsibilities, as designated hereto, impact or involve any of or all of the components of a TMP must successfully complete an advanced work zone traffic control training program. These components include the primary component, the "Temporary Traffic Control" plan, and the secondary components, the "Transportation Operations" plan and the "Public Information" plan.

An employee whose job duties include any of the following responsibilities regarding the TMP shall successfully complete an advanced work zone traffic control training program conducted by an SCDOT approved work zone traffic control training provider:

- Supervision of the field installation of any or all components of the TMP
- Supervision of the maintenance of any or all components of the TMP
- Supervision of the removal of any or all components of the TMP
- Design and development of revisions to an existing TMP
- Design and development of a new or alternate TMP
- Any decision-making responsibilities regarding the TMP

Those employees whose job duties do not include responsibilities relative to the TMP as stated above are not required to attend an advanced work zone traffic control training program. However, it is recommended that all employees whose job duties place them on the job site within the highway rights-of-way within 30 feet or less of a travel lane open to traffic should attend a basic work zone traffic control training course.

Also, an employee whose job duties include "flagger" shall successfully complete a "Flagger Training" course. However, regarding an employee whose job duties includes "flagger" but does not involve any of the responsibilities listed above, successful completion of a "Flagger Training" course is the only mandatory work zone traffic control training course required for this employee; other work zone traffic control training courses are elective.

**4. Approved Work Zone Traffic Control Training Providers:**

## SUPPLEMENTAL SPECIFICATION

Approved work zone traffic control training providers conduct work zone traffic control training in compliance with the MUTCD and reference requirements specific to SCDOT. For a listing of the SCDOT approved work zone traffic control training providers and the approved courses, see the document entitled, "Approved Work Zone Traffic Control Training Guidelines Training Providers / Course For Contractors / Subcontractors" latest edition. This document may be found at the web address below.

<https://www.scdot.org/business/pdf/accessMgt/trafficEngineering/TrainingProvidersListing.pdf>

Work zone traffic control training conducted by affiliates of the SCDOT approved providers in other states will be considered acceptable provided the training is comparable to the employee's job duty responsibilities. For example:

The South Carolina Chapter of the National Safety Council is listed as an acceptable work zone traffic control training provider for the SCDOT. Comparable work zone traffic control training conducted in Texas by the Texas Chapter of the National Safety Council will also be considered acceptable. This scenario applies to each approved work zone traffic control provider who also conducts training outside of South Carolina.

Specific course material for work zone traffic control training courses designated as "Basic", "Advanced", "Supervisor" or "Flagger" and any additional training courses not specified here is determined by the work zone traffic control training course provider and has undergone review and received acceptance by SCDOT. Also, the passing score for each training course is determined by the work zone traffic control provider.

### **5. Training Requirements / Qualifications:**

Successful completion of an advanced work zone traffic control training program is defined as achieving a passing score in all courses, including any prerequisite courses, to attain a level considered "advanced", "supervisor" or any other relative term as designated by the provider to imply the trainee has an understanding of the course material inclusive of design, implementation and maintenance of work zone traffic control scenarios. Upon successful completion of the program, the trainee should also possess an understanding for determining the need for and developing and implementing adjustments as necessary when applying typical work zone traffic control applications to non-typical work site conditions and scenarios.

The employee whose job duty responsibilities mandate successful completion of an advanced work zone traffic control training program shall do so prior to performing any job duties with responsibilities relative to design and development of a TMP or revisions of an existing TMP or any decision-making responsibilities regarding the TMP or supervision of the field installation and maintenance of any and all components of the TMP.

Also, an employee whose job duties mandate successful completion of a "Flagger" training course shall do so prior to performing any job duties relative to flagging traffic.

Each employee who has successfully completed an approved advanced work zone traffic control training program or a "Flagger" training course shall attend and complete a refresher course relative to the employee's job duties on a 5-year incremental time frame.

### **6. Documentation:**

The contractor shall provide proof of successful completion of an acceptable advanced work zone traffic control training class by those employees whose job duty responsibilities mandate successful completion of approved work zone traffic control training to the Resident Engineer prior to the employee performing the job duties that incorporate responsibilities which necessitate approved work zone traffic control training. For proof of successful completion of an approved work zone traffic control training class, provide a copy of the certificate of training from the organization who conducted the training to the Resident Engineer. Failure to provide the required documentation as specified shall prevent SCDOT acceptance of the employee as properly trained and acceptable for conducting those job duties that necessitate the prescribed work zone traffic control training.

## SUPPLEMENTAL SPECIFICATION

The contractor shall provide proof of successful completion of an acceptable "Flagger Training" course by all employees whose job duties require them to be the "Flagger" within a flagging operation to the Resident Engineer prior to the employee performing any "Flagger" job duties.

The contractor shall provide proof of successful completion of an acceptable advanced work zone traffic control refresher course for those employees no later than 60 days beyond the 5 year anniversary date of the employee's certificate date of completion of a previous advanced work zone traffic control training program.

Documentation of proof of completion of a basic work zone traffic control training course by employees whose job duties require their presence on the job site within the highway rights-of-way but exclude any responsibilities relative to the TMP is not required.

January 1, 2018

**Removal of Existing Asphalt Pavement before Patching**

Delete Subsection 401.4.14 Removal of Existing Asphalt Pavement before Patching, of the Standard Specifications in its entirety and replace with the following:

The **RCE** will determine the limits of distressed pavement and will mark width and length of patches. **RCE / RME** will inspect the road and ensures that drainage is adequate and no additional work needs to be done to the ditches and shoulders to promote proper drainage. The **RCE** may elect to obtain random cores if needed to determine proper depth of distressed area to be patched. Construct patches with a minimum size of 6.5 feet x 6.5 feet with at least 25 feet between patches. Care should be taken to ensure that longitudinal joints do not end up in the wheel paths. In the event that considerable quantities of full depth patching (FDP) are encountered, the RCE will consult with the State Pavement Design Engineer to consider other rehabilitation methods.

Remove the pavement to the depth indicated in the Plans, ensuring that the face of the cut is straight and vertical, with the exception of tapers needed to get equipment in and out of the patched area. If unstable material is encountered, remove additional material as directed by the **RCE**. Backfill the volume of the material removed below the patch with material meeting the requirements of **Section 305**, Graded Aggregate Base, and thoroughly compact in layers not exceeding 4 inches with a vibratory compactor. Thoroughly tack the sides of the existing pavement before placing the asphalt patch material in the hole.

Place the patch material in relatively uniform layers not to exceed the number of lifts in the table below. Ensure that the patch material is selected from the table below. Compact each layer with a vibratory compactor and a pneumatic roller. Whenever practical, allow lifts to cool down prior to placing the next lift, especially when doing multiple patches in the same area. The 175° F requirement between lifts does not apply to FDP. Conduct the work so that patches are opened and filled each day, with the roadway being opened to traffic by the end of each days operation.. Ensure that the finished patch is smooth riding by using a straight edge. Temperature and calendar restrictions found in **Section 401.4.4** do not apply, however no FDP will be permitted if the area is wet or frozen prior to removing the old pavement.

<b>Full Depth Patching Materials</b>		
<b>Depth of FDP</b>	<b>Select mixture type below based on Depth of FDP</b>	
	<b>Alternate Mixture Options</b>	<b>Typical Mixture</b>
4" or Less	Surface Type B / C 2 Lifts	Intermediate C 2 Lifts
6"	Surface Type B / C 2 Lifts	Intermediate C 2 Lifts
8"	Intermediate B Special 2 lifts	Intermediate C 3 lifts
10"	Intermediate B Special 2 lifts	Intermediate C 3 lifts
12" or More	Consult with the State Pavement Design Engineer	

January 1, 2019

**Asphalt Binder and Additives**

**Delete Subsection 401.2.1.1, Binder and Additives, General of the Standard Specification in its entirety and replace it with the following:**

**401.2.1.1 Performance Graded (PG) Binder**

Use PG 64-22 or PG 76-22 binder as required by the contract that conforms to all of the requirements of AASHTO M 320. Do not use any combination of "air blown" asphalt binders. Ensure that the asphalt binder supplier lists all types of modifiers and additives used in the production of their PG binders including source of Re-Refined Engine Oil Bottoms (REOB), polymers, ground tire rubber (GTR), polyphosphoric acid (PPA), silicone, and liquid anti-stripping agent (LASA) in their Quality Control Plans. Ensure that additives used for compaction aides or anti-strips such as silicones, WMA additives, and LASA products are listed on the Bill of Lading (BOL). Use PG asphalt binders and modifiers that are heat and storage stable. Thoroughly blend the composite materials at the asphalt terminal before being loaded into the transport vehicle. Asphalt terminals that either supply or produce PG binders must be able to store multiple tanker loads of PG and certify that their products meet AASHTO M 320 prior to transferring or shipping on the BOL and that all modifiers and additives are compatible. Ensure that all PG binders adhere to *SCDOT Qualified Products Policy No. 37-38*. Only use PG 64-22 and PG 76-22 binder from sources listed on the most recent edition of *SCDOT Qualified Product List 37*.

**401.2.1.1.1 Modified Performance Graded Binder**

When specified, use modified binder consisting of a neat binder modified with a polymer or other modifier producing a binder complying with the requirements of a PG 76-22 as specified in AASHTO M 320 with the addition of the Multiple Stress Creep Recovery (MSCR) test using AASHTO T 350. Ensure acceptable elastomeric polymer is used by using Non-recoverable Creep Compliance values plotted against Percent Recovery based on figure 1 found in AASHTO R92 using RTFO aged material. Ensure that the MSCR test is performed at 64°C using the Very Heavy Traffic "V" Grade requirement in AASHTO M 332. Use elastomer polymer or modifier consisting of a styrene-butadiene (SB), styrene-butadiene-styrene (SBS), styrene-butadiene-rubber (SBR), or ground tire rubber (GTR). Polyphosphoric Acid (PPA) may also be added to the binder, but must not exceed 0.5% by weight of the asphalt binder. Varying blends of SB, SBS, SBR, GTR (7% min.), and PPA (0.5% max.) may be used, at the discretion of the AME, provided the end product meets all specified requirements for the PG 76-22. Perform the storage stability separation test ASTM D7173 to ensure the asphalt binder is homogenous. Ensure that all storage tanks on the asphalt plant site are clearly marked to prevent cross contamination of different PG binders.

**401.2.1.1.1.1 Ground Tire Rubber (GTR) in Performance Graded Binder**

Ensure that the Ground Tire Rubber (GTR) is terminally (no exceptions) blended with the neat asphalt to create a homogenous and storage stable PG 76-22 that meets all criteria as stated in 401.2.1.1.1, with the exception of Solubility requirement (AASHTO T 44). Blending the GTR modified binder at the asphalt plant during asphalt mixture production will not be permitted. Use a 2.0mm gap setting when using the DSR in accordance to AASHTO T 315 and AASHTO T 350. GTR materials must be free from excessive moisture when received from the tire recycling facility and stored in a dry location at the terminal to prevent blending issues with the binder modification process. A letter of compliance from the tire recycling facility will be required by the AME and the asphalt terminal stating that the GTR blend will meet this specification. The GTR must be free of loose metal particles, other foreign contaminating materials, with exception of embedded metal particles in the rubber. Mineral powder may be added to reduce sticking and caking of the GTR particles. Stabilizing or compatibility additive(s) can be used to achieve better particle distribution. Any additives used for this purpose must not be detrimental to the performance of the asphalt binder or mixture performance and must be accepted by the AME in the supplier's QC plan. Ensure that the GTR supplier provides certificates of compliance with each shipment certifying that all requirements of this specification are complied with for each production lot number and the end product is homogenous and shows no signs of separation or coagulation. In the event that the terminal changes supply sources of GTR type of grind



**SUPPLEMENTAL SPECIFICATION**

(ambient or cryogenic), or particle size, the asphalt terminal must perform a complete binder analysis on their revised product, and also provide a split sample to the SCDOT to ensure specification compliance.

Provide all sources of GTR and grind type in the asphalt terminal's QC plan. SCDOT may obtain samples of the GTR particles, base binder, or the finished GTR modified asphalt binder to ensure specification compliance at any time.

<b>Physical Test</b>	<b>Test Procedure</b>	<b>Specification</b>
Sampling of the GTR	ASTM E105 ASTM E122	In accordance to random sampling procedures
GTR Supply	ASTM D5603	Ambient or Cryogenic Grind
Dosage of GTR	Per COA & Supplier's QC Plan	Minimum of 7.0% by weight of the PG 64-22 base asphalt binder
GTR Specific Gravity	ASTM D5603	1.06 – 1.20
GTR Particle Distribution	ASTM D5644	30 Mesh Maximum of 2.0% Retained
GTR Metal Content	ASTM D5603	Maximum 0.01%
GTR Fiber Content	ASTM D5603	Maximum 0.50%
GTR Moisture Content	ASTM D1509	Maximum 0.75%
Mineral Filler –Talcum Powder (Optional)	ASTM M17	Maximum of 4.0%
Stabilizing Additives (Optional)	-	Maximum of 4.5% by wt. of GTR

<b>Chemical Test</b>	<b>Test Procedure</b>	<b>Specification</b>
Acetone Extract	ASTM D297	Maximum 25.0%
Rubber Hydrocarbon Content		40.0 – 60.0 %
Ash Content		Maximum 8.0 %
Carbon Black Content		20.0 – 40.0 %
Natural Rubber		16.0 – 45.0 %

**401.2.1.1.1.2 Ground Tire Rubber in Open Graded Friction Course or SMA Mixtures**

Stabilizing fibers and fiber supply systems at the asphalt plant may not be necessary when the GTR binder is used as required by section 409.2.3 and 409.4.3 of the Standard Specifications or any other Supplemental Specification for OGFC or SMA. Perform the SC-T-90 drain-down procedure at 350°F when conducting the asphalt mix design, or otherwise directed by the AME. In the event that drain-down values are found to be excessive, then stabilizing fibers may be necessary as directed by the AME. No additional compensation will be paid for the fibers in the OGFC or SMA mixture.

**401.2.1.1.1.3 Asphalt Plant Storage Requirements When Using Ground Tire Rubber**

Use a dedicated storage tank for "terminal blended GTR asphalt binder" at the asphalt plant. This tank must be capable of providing continuous mixing, as well as recirculation of the GTR asphalt binder as needed. Ensure that this tank is heated and capable of maintaining the temperature of the homogeneous blend of asphalt binder and GTR at 300°F to 350°F. Ensure that GTR modified binders are not mixed with other modified PG 76-22 binder without permission of the AME.

# **PROPOSAL SECTION**

**BID TABULATION**  
**COLLETON COUNTY CAREER CENTER PAVING**  
 1/7/2022

<u>PAY ITEM</u>	<u>DESCRIPTION</u>	<u>QUANTITY</u>	<u>UNIT</u>	<u>UNIT COST</u>	<u>TOTAL</u>
1031000	MOBILIZATION	1.00	LS		
1032010	BONDS AND INSURANCE	1.00	LS		
1050800	CONSTRUCTION STAKES, LINES & GRADES	1.00	EA		
1071000	TRAFFIC CONTROL	1.00	LS		
2025000	REMOVAL & DISPOSAL OF EXISTING ASPHALT PAVEMENT	4,473.00	SY		
3050108	GRADED AGGREGATE BASE COURSE (8" UNIFORM)	4,473.00	SY		
4011004	LIQUID ASPHALT BINDER PG64-22	29.52	TON		
4030320	HOT MIX ASPHALT SURFACE COURSE TYPE B (220 LB/SY)	492.03	TON		
6271010	4" WHITE SOLID LINES (PVT. EDGE LINES/PARKING STRIPE) THERMO.- 90 MIL.	294.00	LF		
62710XX	4" BLUE SOLID LINES (PVT. EDGE LINES/PARKING STRIPE) THERMO.- 90 MIL.	140.00	LF		
6271025	24" WHITE SOLID LINES (STOP/DIAG LINES)-THERMO.-125 MIL	32.00	LF		
6271050	HANDICAP SYMBOL - THERMOPLASTIC - 125 MIL.	2.00	EA		
8100101	PERMANENT GRASSING	0.50	AC		
8153000	SILT FENCE	500.00	LF		
9999992	REMOVAL / REPLACEMENT SIGNAGE	1.00	LS		
9999993	ASPHALT INSPECTION AND MATERIALS TESTING	1.00	LS		

**ALTERNATIVE 1**

3063308	CEMENT MODIFIED RECYCLED BASE (8" UNIFORM)	4,473.00	SY		
3064000	PORTLAND CEMENT FOR CEMENT MODIFIED RECYCLED BASE COURSE (50 LB/SY)	111.83	TON		

**TOTAL: 50.00**

NOTE: Payment for the accepted quantity of HMA Surface Course of the type specified will be paid for at the contract unit price bid or the Monthly Fuel Price Index. No adjustment of the contract unit price will be made due to fluctuations in the Monthly Asphalt Price. Contractor to submit a schedule and proposed completion date with their bid.

**THUNDERBOLT CAREER AND TECHNOLOGY CENTER PAVING  
PROPOSAL FORM**

**DATE:** \_\_\_\_\_

Gentlemen:

In compliance with your invitation for bids, the undersigned hereby proposes to furnish all labor, equipment and materials, and to perform all work for the project referred to herein as:

**THUNDERBOLT CAREER AND TECHNOLOGY CENTER PAVING**

in strict accordance with the Contract Documents and in consideration of the amounts shown on the bid schedule attached hereto and totaling:

\_\_\_\_\_  
\_\_\_\_\_, and \_\_\_\_\_/100 dollars ( \$ \_\_\_\_\_ )

The undersigned hereby agrees that, upon written acceptance of this bid, he/she will within 10 days of receipt of such notice execute a formal contract agreement with the Owner, and that he/she will provide the bond or guarantees required by the contract documents.

The undersigned hereby agrees that, if awarded the contract, he/she will commence the work within Ten (10) calendar days after the date of written notice to proceed, and that he/she will complete the work within Sixty (60) calendar days after the date of such notice.

The undersigned acknowledges receipt of the following addenda:

\_\_\_\_\_

Enclosed is a bid guarantee, consisting of \_\_\_\_\_  
in the amount of \_\_\_\_\_.

Respectfully submitted,

\_\_\_\_\_  
FIRM NAME

\_\_\_\_\_  
BUSINESS ADDRESS

BY: \_\_\_\_\_

TITLE: \_\_\_\_\_

**THUNDERBOLT CAREER AND TECHNOLOGY CENTER PAVING  
CERTIFICATION FORM**

**PROJECT: THUNDERBOLT CAREER AND TECHNOLOGY CENTER PAVING**

**Failure to perform the above selections and requirements or to execute the certification below will make the bid non-responsive and not eligible for award consideration.**

By submitting this bid, I hereby acknowledge that all requirements included in the hard copy proposal, addendums, amendments, plans, standard specifications, supplemental specifications, and special provisions are part of this bid proposal and contract.

In accordance with the provisions of S.C. Code ANN.§§ 39-3-10 et. seq., 39-5-10 et. seq., 15 U.S.C. §45; 23 C.F.R.§635.112(F); and 28U.S.C.§1746, that I am an officer of the proposer firm and, under penalty of perjury under the laws of the United States and South Carolina, declare, by my certification below, that the following is true and correct, and further, that this firm, association or corporation has not, either directly or indirectly, entered into any agreement, participated in any collusion, or otherwise taken any action in restraint of free competitive bidding in connection with the submission of a bid proposal on the above referenced project.

By checking this box , I certify that I have read, understand, accept, and acknowledge all of the above statements.

Executed on \_\_\_\_\_ 20\_\_\_\_.

Signed: \_\_\_\_\_

(Officer/Proposer)

\_\_\_\_\_  
(Title)

\_\_\_\_\_  
(Company)

\_\_\_\_\_  
(Address)

SEAL

**THUNDERBOLT CAREER AND TECHNOLOGY CENTER PAVING  
NOTICE OF AWARD**

SUBJECT: NOTICE OF AWARD  
PROJECT: THUNDERBOLT CAREER AND TECHNOLOGY CENTER PAVING

Gentlemen:

The Owner has considered the BID submitted by you for the above described WORK in response to its Advertisement for Bids and Information for Bidders.

You are hereby notified that your BID has been accepted for items in the amount of

\_\_\_\_\_ Dollars (\$ \_\_\_\_\_)

You have agreed in your Proposal to execute the Agreement and furnish the required Contractor's Performance Bond and Payment Bond within Ten (10) calendar days from the date of this Notice to you.

If you fail to execute said Agreement and to furnish said Bonds within Ten (10) days from the date of this Notice, said OWNER will be entitled to consider all your rights arising out of the OWNER'S acceptance of your BID as abandoned and as a forfeiture of your Bid Bond. The OWNER will be entitled to such other rights as may be granted by law.

You are required to return an acknowledged copy of this NOTICE OF AWARD to the OWNER.

Dated this \_\_\_\_\_ day of \_\_\_\_\_, \_\_\_\_.

Sincerely,

Cranston Engineering Group, P.C.

Matt Randall, PE

**\*\*\*ACCEPTANCE OF NOTICE\*\*\***

Receipt of the above NOTICE OF AWARD is hereby acknowledged by \_\_\_\_\_

this the \_\_\_\_\_ day of \_\_\_\_\_, 20\_\_\_\_

BY: \_\_\_\_\_ TITLE: \_\_\_\_\_

**THUNDERBOLT CAREER AND TECHNOLOGY CENTER PAVING AGREEMENT**

THIS AGREEMENT, made on the \_\_\_\_\_ of \_\_\_\_\_, 2021  
by and between COLLETON COUNTY SCHOOL DISTRICT, party of the first part, hereinafter called the OWNER, and \_\_\_\_\_,  
party of the second part, hereinafter called the CONTRACTOR.

WITNESSETH, that the Contractor and the Owner, for the considerations hereinafter named, agree as follows:

**ARTICLE I - SCOPE OF THE WORK**

The Contractor hereby agrees to furnish all of the materials and all of the equipment and labor necessary, and to perform all of the work shown on the plans described in the specifications for the project entitled:

**2022 THUNDERBOLT CAREER AND TECHNOLOGY CENTER PAVING**

and in accordance with the requirements and provisions of the Contract Documents as defined in the General and Special Conditions hereto attached which are hereby made a part of this agreement.

**ARTICLE II - TIME OF COMPLETION -- LIQUIDATED DAMAGES**

The work to be performed under this Contract shall be commenced within ten (10) calendar days after the date of written notice by the Owner to the Contractor to proceed. The work shall be completed within Sixty (60) calendar days after the date of such notice and with such extensions of time as are provided for in the General Conditions.

It is hereby understood and mutually agreed, by and between the Contractor and the Owner, that the date of beginning, rate of progress and the time for completion of the work to be done hereunder are ESSENTIAL CONDITIONS of this Contract. Contractor agrees that said work shall be prosecuted regularly, diligently, and uninterruptedly at such rate of progress as will ensure full completion thereof within the time specified. It is expressly understood and agreed by and between the Contractor and the Owner, that the time for the completion of the work described herein is a reasonable time for the completion of the same, taking into consideration the average climatic range and construction conditions prevailing in this locality.

It is further agreed that time is of the essence of each and every portion of this contract and of the specifications wherein a definite portion and certain length of time is fixed for the performance of any act whatsoever; and where under the contract an additional time is allowed for the completion of any work, the new time limit fixed by extension shall be the essence of the Contract.

# THUNDERBOLT CAREER AND TECHNOLOGY CENTER PAVING

## ARTICLE III - PAYMENT

### A. THE CONTRACT SUM

The Owner shall pay to the Contractor for the performance of the Contract the amounts determined for the total number of each of the units of work in the attached schedule completed at the unit price stated. The number of units contained in this schedule is approximate only, and the final payment shall be made for the actual number of units that are incorporated in or made necessary by the work covered by the Contract.

### B. PROGRESS PAYMENTS

On not later than the fifth day of every month, the Contractor shall submit to the Engineer an estimate covering the percentage of the total amount of the Contract which has been completed from the start of the job up to and including the last working day of the preceding month, together with such supporting evidence as may be required by the Owner or/and the Engineer. The estimate shall include only quantities in place and at the unit prices set forth in the bid schedule. Within ten (10) days of receiving each Application for Payment, the Engineer shall either indicate in writing a recommendation of payment and present the application to the Owner or return the Application to the Contractor indicating in writing necessary corrections. In the latter case, the Contractor shall make the corrections and resubmit the application.

Fifteen days after presentation of the Application for Payment to the Owner with the Engineer's recommendation, the Owner shall, after deducting previous payments made, pay to the Contractor 90% of the amount of the estimate on units accepted in place. The 10% retained percentage may be held by the Owner until the final completion and acceptance of all work under the Contract.



# THUNDERBOLT CAREER AND TECHNOLOGY CENTER PAVING

## ARTICLE IV - ACCEPTANCE AND FINAL PAYMENT

- A. Upon receipt of written notice that the work is ready for final inspection and acceptance, the Engineer shall within 10 days make such inspection, and when he finds the work acceptable under the Contract and the Contract fully performed he will promptly issue a final certificate, over his own signature, stating that the work required by the Contract has been completed and is accepted by him under the terms and conditions thereof, and the entire balance found to be due the Contractor, including the retained percentage, shall be paid to the Contractor by the Owner within 20 days after the date of said final certificate.
- B. Before final payment is due the Contractor shall submit evidence satisfactory to the Engineer that all payrolls, material bills, and other indebtedness connected with the work have been paid, except that in case of disputed indebtedness or liens the Contractor may submit in lieu of evidence of payment a surety bond satisfactory to the Owner guaranteeing payment of all such disputed amounts when adjudicated in cases where such payment has not already been guaranteed by surety bond.
- C. The making and acceptance of the final payment shall constitute a waiver of all claims by the Owner other than those arising from unsettled liens, from faulty work appearing within 12 months after final payment, from requirements of the specifications, or from manufacturers' guarantees. It shall also constitute a waiver of all claims by the Contractor except those previously made and still unsettled.

IN WITNESS WHEREOF the parties hereto have executed this Agreement, the day and year first written above.

WITNESS:

**COLLETON COUNTY SCHOOL DISTRICT  
OWNER**

\_\_\_\_\_

BY: \_\_\_\_\_  
AS ITS MANAGER

WITNESS:

**CONTRACTOR**

\_\_\_\_\_

BY: \_\_\_\_\_

TITLE

**THUNDERBOLT CAREER AND TECHNOLOGY CENTER PAVING  
PERFORMANCE BOND**

(NOTE: THIS BOND IS ISSUED SIMULTANEOUSLY WITH PAYMENT BOND ON PAGE 133, IN FAVOR OF THE OWNER CONDITIONED FOR THE PAYMENT OF LABOR AND MATERIAL.)

KNOW ALL MEN BY THESE PRESENTS:

That \_\_\_\_\_ as Principal, hereinafter called Contractor, and a corporation organized and existing under the laws of the State of \_\_\_\_\_, with its principal office in the City of \_\_\_\_\_, State of \_\_\_\_\_, as Surety, hereinafter called Surety, are held and firmly bound unto COLLETON COUNTY SCHOOL DISTRICT, as Obligee, hereinafter called the Owner, in the penal amount of \_\_\_\_\_ Dollars (\$ \_\_\_\_\_) for the payment whereof Contractor and Surety bind themselves, their heirs, executors, administrators, successors, and assigns, jointly and severally, firmly by these presents for the faithful performance of a certain written agreement.

WHEREAS, Contractor has by said written agreement dated \_\_\_\_\_ entered into a contract with Owner for the construction of **THUNDERBOLT CAREER AND TECHNOLOGY CENTER PAVING** in accordance with the drawings and specifications which contract is by reference made a part hereof and is hereinafter referred to as the **CONTRACT**.

NOW, THEREFORE, the condition of this obligation is such that, if Contractor shall promptly and faithfully perform said **CONTRACT**, then this obligation shall be null and void; otherwise, it shall remain in full force and effect.

The Surety hereby waives notice of any alteration or extension of time made by the Owner.

Whenever Contractor shall be, and declared by Owner to be in default under the **CONTRACT**, the Owner having performed Owner's obligations thereunder, the Surety may promptly remedy the default, or shall promptly

1. Complete the **CONTRACT** in accordance with its terms and conditions, or
2. Obtain a bid or bids for completing the Contract in accordance with its terms and conditions, and upon determination by Surety of the lowest responsible bidder, or, if the Owner elects, upon determination by the Owner and the Surety jointly of the lowest responsible bidder, arrange for a contract between such bidder and Owner,

**THUNDERBOLT CAREER AND TECHNOLOGY CENTER PAVING**

and make available as Work progresses (even though there should be a default or a succession of defaults under the contract or contracts of completion arranged under this paragraph) sufficient funds to pay the cost of completion less the balance of the contract price; but not exceeding, including other costs and damages for which the Surety may be liable hereunder, the amount set forth in the first paragraph hereof. The term "balance of the contract price," as used in this paragraph, shall mean the total amount payable by Owner to Contractor under the Contract and any amendments thereto, less the amount properly paid by Owner to Contractor.

Any suit under this bond must be instituted before the expiration of one (1) year from the date on which final payment under the CONTRACT falls due.

No right of action shall accrue on this bond to or for the use of any person or corporation other than the Owner named herein or the heirs, executors, administrators or successors of the Owner.

Signed and sealed this \_\_\_\_\_ day of \_\_\_\_\_ A.D. 20\_\_.

Witness \_\_\_\_\_ (Seal)  
(Contractor)

Attest \_\_\_\_\_ By \_\_\_\_\_ (Seal)  
(Title)

Witness \_\_\_\_\_ (Seal)  
(Surety)

Attest \_\_\_\_\_ By \_\_\_\_\_ (Seal)  
(Title)

**THUNDERBOLT CAREER AND TECHNOLOGY CENTER PAVING  
LABOR AND MATERIAL PAYMENT BOND**

(NOTE: THIS BOND IS ISSUED SIMULTANEOUSLY WITH PERFORMANCE BOND ON PAGE 131, IN FAVOR OF THE OWNER CONDITIONED FOR THE PERFORMANCE OF THE WORK.)

KNOW ALL MEN BY THESE PRESENTS:

That \_\_\_\_\_ as Principal, hereinafter called Contractor,  
and \_\_\_\_\_ a corporation organized and  
existing under the laws of the State of \_\_\_\_\_, with its principal office in the City of  
\_\_\_\_\_, State of \_\_\_\_\_, as Surety, hereinafter called Surety,  
are held, and firmly bound unto COLLETON COUNTY SCHOOL DISTRICT, as  
Obligee, hereinafter called the Owner, for the use and benefit of claimants as herein below defined  
in the amount of \_\_\_\_\_, Dollars (\$ \_\_\_\_\_)  
for the payment whereof Contractor and Surety bind themselves, their heirs, executors,  
administrators, successors, and assigns, jointly and severally, firmly by these presents.

WHEREAS, Contractor has by written agreement dated \_\_\_\_\_ entered into  
a contract with Owner for the construction of **THUNDERBOLT CAREER AND  
TECHNOLOGY CENTER PAVING**, in accordance with drawings and specifications which  
contract is by reference made a part hereof and is hereinafter referred to as the **CONTRACT**.

NOW, THEREFORE, the condition of this obligation is such that, if the Contractor shall  
promptly make payment to all claimants as hereinafter defined, for all labor and material used or  
reasonably required to use in the performance of the **CONTRACT**, then this obligation shall be  
void; otherwise, it shall remain in full force and effect, subject, however, to the following  
conditions:

1. A claimant is defined as one having a direct contract with the Contractor or with a subcontractor of the Contractor for labor, material, or both, used or reasonably required for use in the performance of the contract, labor and material being construed as to include that part of water, gas, power, light, heat, oil, gasoline, telephone service or rental of equipment directly applicable to the **CONTRACT**.
2. The above named Contractor and Surety hereby jointly and severally agree with the Owner that every claimant as herein defined, who has not been paid in full before the expiration of a period of Sixty (60) days after the date on which the last of such

## **THUNDERBOLT CAREER AND TECHNOLOGY CENTER PAVING**

claimant's work or labor was done or performed, or materials were furnished by such claimant, may sue on this bond for the use of such claimant, prosecute the suit to final judgment for such sum or sums as may be justly due claimant, and have execution thereon. The Owner shall not be liable for the payment of any costs or expenses of any such suit.

3. No suit or action shall be commenced hereunder by any claimant,
  - a) Unless claimant, other than one having a direct contract with the Contractor, shall have given written notice to any two of the following: The Contractor, the Owner, or the Surety above named, within Sixty (60) days after such claimant did or performed the last of the work or labor, or furnished the last of the materials for which said claim is made, stating with substantial accuracy the amount claimed and the name of the party to whom the materials were furnished, or for whom the work or labor was done or performed. Such notice shall be served by mailing the same by registered mail or certified mail, postage prepaid, in an envelope addressed to the Contractor, Owner or Surety, at any place where an office regularly maintained for the transaction of business or served in any manner in which legal process may be served in the state in which the aforesaid project is located, save that such service need not be made by a public officer.
  - b) After the expiration of one (1) year following the date on which Contractor ceased work on said CONTRACT, it being understood, however, that if any limitation embodied in this bond is prohibited by any law controlling the construction hereof, such limitation shall be deemed to be amended so as to be equal to the minimum period of limitation permitted by such law.
  - c) Other than in a state court of competent jurisdiction in and for the county or other political subdivision of the state in which the project, or any part thereof, is situated, or in the United States District Court for the district in which the project, or any part thereof, is situated, and not elsewhere.
4. The amount of this bond shall be reduced by and to the extent of any payment or payments made in good faith hereunder, inclusive of the payment by Surety of mechanics' liens which may be filed of record against said improvement, whether or not claim for the amount of such lien be presented under and against this bond.

**THUNDERBOLT CAREER AND TECHNOLOGY CENTER PAVING**

Signed and sealed this \_\_\_\_\_ day of \_\_\_\_\_ A.D. 20\_\_.

Witness \_\_\_\_\_ (Seal)  
\_\_\_\_\_ (Contractor)

Attest \_\_\_\_\_ By \_\_\_\_\_ (Seal)  
\_\_\_\_\_ (Title)

Witness \_\_\_\_\_ (Seal)  
\_\_\_\_\_ (Surety)

Attest \_\_\_\_\_ By \_\_\_\_\_ (Seal)

**THUNDERBOLT CAREER AND TECHNOLOGY CENTER PAVING**

**THUNDERBOLT CAREER AND TECHNOLOGY CENTER**  
**PAVING**

DATE \_\_\_\_\_

Address \_\_\_\_\_

SUBJECT: NOTICE TO PROCEED  
PROJECT: **THUNDERBOLT CAREER AND TECHNOLOGY CENTER  
PAVING**

Gentlemen:

You are hereby notified to commence work in accordance with the Agreement, within Ten (10) calendar days following the date first written above, and you are to complete the work within SIXTY (60) consecutive calendar days after the date of this notice. The date set for completion of all work is, therefore \_\_\_\_\_.

Sincerely,

Kenny Blakeney  
Director of Buildings and Grounds  
Colleton County School District

**\*\*\*ACCEPTANCE OF NOTICE\*\*\***

Receipt of the above NOTICE TO PROCEED is hereby acknowledged by \_\_\_\_\_

this the \_\_\_\_\_ day of \_\_\_\_\_, 20\_\_\_\_.

BY: \_\_\_\_\_

TITLE: \_\_\_\_\_

- DEMOLITION NOTES:**
1. THE CONTRACTOR SHALL CALL IN LOCATES OF UNDERGROUND UTILITIES PRIOR TO BEGINNING CONSTRUCTION.
  2. PRIOR TO BEGINNING CONSTRUCTION, THE CONTRACTOR SHALL INSTALL PERIMETER SILT FENCE AND INLET PROTECTION IN ACCORDANCE WITH THE EROSION, SEDIMENTATION & POLLUTION CONTROL PLAN.
  3. BEFORE ANY DEMOLITION, UNDERGRASSING, CLEARING, TREE REMOVAL, SOIL REMOVAL, OR ANY OTHER SITE WORK BEGINS, COUNTY STAFF MUST INSPECT THE SITE TO ENSURE ANY REQUIRED EROSION CONTROLS AND/OR TREE PROTECTION IS INSTALLED.
  4. THE CONTRACTOR SHALL PROVIDE DUST CONTROL MEASURES FOR ALL DEMOLISHED AREAS BY WATER TRUCK OR OTHER SUFFICIENT MEASURES.
  5. ALL MATERIALS GENERATED FROM DEMOLITION OF THE EXISTING SITE FEATURES SHALL BE DISPOSED OF OFF-SITE IN ACCORDANCE WITH ALL STATE & LOCAL GUIDELINES.
  6. NO MATERIALS SHALL BE BURIED ON SITE.
  7. THE CONTRACTOR SHALL CONTACT ANY UTILITY PROVIDER WHOSE SERVICE MAY BE AFFECTED BY THE PROPOSED WORK PRIOR TO WORK ON THESE UTILITIES.
  8. NO WORK SHALL BE COMPLETED IN SOUTH CAROLINA DEPARTMENT OF TRANSPORTATION RIGHT-OF-WAY WITHOUT AN ENGAGEMENT PERMIT.
  9. THE CONTRACTOR SHALL COORDINATE ALL REMOVAL AND RELOCATION OF EXISTING SITE LIGHTING FIXTURES WITH DOMINION ENERGY.
  10. WATER AND SEWER SERVICES TO BUILDINGS ARE TO BE LOCATED, PROTECTED AND INSPECTED FOR DAMAGE TO ASSESS CURRENT CONDITION PRIOR TO RE-USE.
  11. ALL NEWLY GRADED AREAS THAT HAVE BEEN BROUGHT TO FINAL GRADE SHALL BE STABILIZED USING TEMPORARY SEEDING WITHIN 14 DAYS OF THE END OF DISTURBANCE.
  12. ALL BMP'S SHALL BE INSPECTED DAILY AND REPAIRED AS NECESSARY.
  13. THE CONCRETE WASHDOWN SHALL BE INSTALLED PRIOR TO COMMENCEMENT OF PAVING OPERATIONS.
  14. ANY AREAS OF EROSION THAT OCCUR PRIOR TO FINAL STABILIZATION SHALL BE REPAIRED BY THE CONTRACTOR.
  15. THE CONTRACTOR SHALL ENSURE FINAL STABILIZATION BY SEEDING ALL DISTURBED AREAS BY PERMANENT GRASSES AND PLANTING IN ACCORDANCE WITH THE APPROVED LANDSCAPE PLAN.
  16. ONCE GRASSING HAS A 70% DENSITY OF THE ENTIRE COVERAGE AREA, THE EROSION CONTROL BMP'S CAN BE REMOVED.
  17. THE ONLY STORM WATER POLLUTANT ANTICIPATED DURING CONSTRUCTION IS SEDIMENT. THE BMP'S INCLUDED ON THIS PLAN ARE DESIGNED TO REDUCE THE SEDIMENT.
  18. MAINTAIN EXISTING SIGNAGE, FENCING, AND CURBING

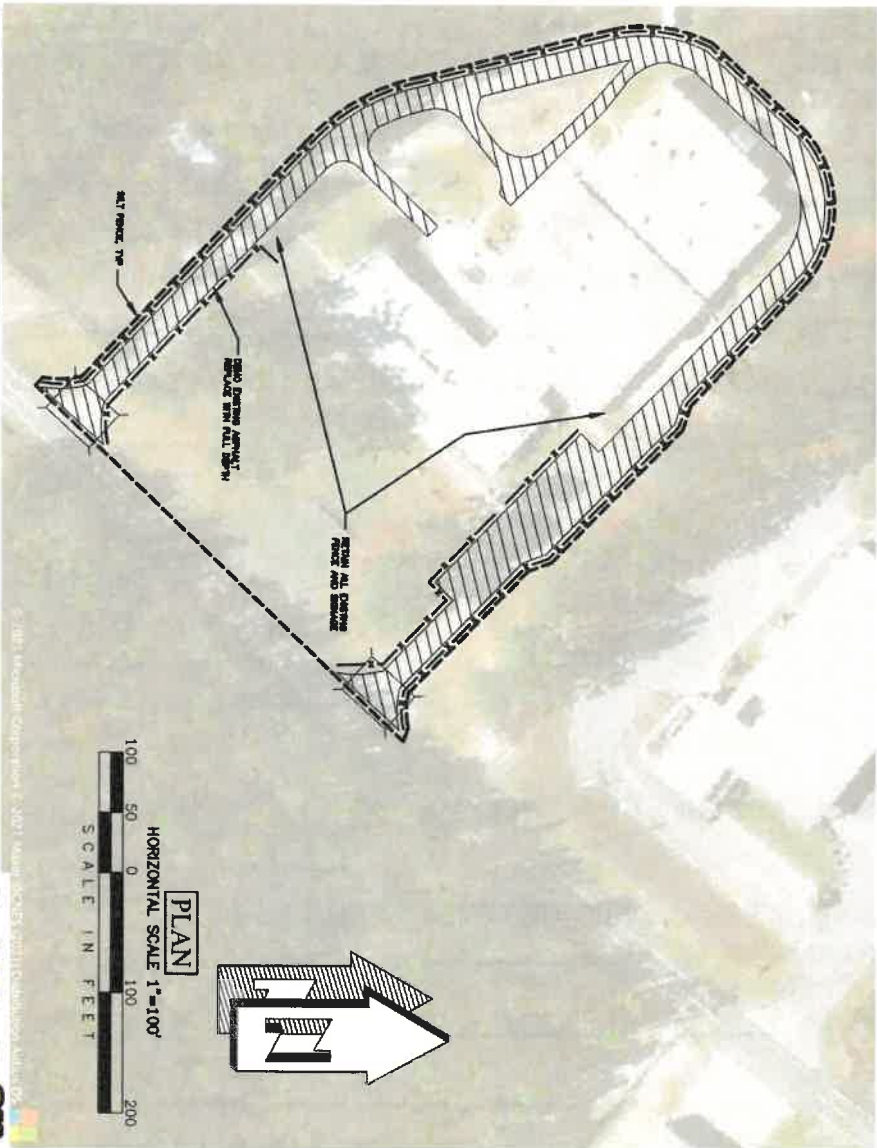

South Carolina  
Department of Health and Environmental Control  
MAINTAINING SYSTEMS FOR PRODUCTION AND EROSION CONTROL PLANS

EXHIBIT

CONSTRUCTION ENTRANCE

SILT FENCE

SEDIMENT TUBE

LIMITS OF DISTURBANCE



SHEET 01	THUNDERBOLT CAREER AND TECHNOLOGY CENTER PAVING		DRAWN PAG	CHECKED MER	APPROVED MER
	DEMOLITION AND SWPP PLAN				
JOB NO. 2021-0330	DATE 1/10/2022				



**CRANSTON**  
ENGINEERING



SEDIMENT TUBE INSTALLATION

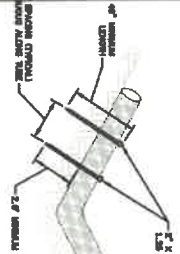

SEDIMENT TUBE SPACING

SLOPE	MAXIMUM TUBE SPACING
1:1	15'-0"
2%	10'-0"
4%	8'-0"
6%	6'-0"
8%	5'-0"
GREATER THAN 8%	3'-0"

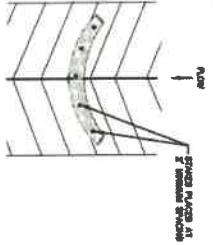

PLAN SYMBOL

SMITH CAROLINA DEPARTMENT OF PUBLIC HEALTH  
STANDARD DRAWING NO. S-2000 (REV. 1/17/2022)

SILT FENCE INSTALLATION

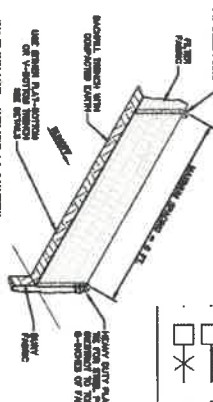

PLAN SYMBOL

SILT FENCE - GENERAL NOTES

1. THE SILT FENCE SHALL BE INSTALLED ALONG THE PERIMETER OF THE CONSTRUCTION SITE TO PREVENT OFF-SITE POLLUTION OF ADJACENT STRIPED AREAS.
2. THE SILT FENCE SHALL BE CONSTRUCTED USING 2x4 POSTS AND 1/2" FABRIC FILTER FABRIC. THE POSTS SHALL BE SPACED AT 10' ON CENTER.
3. THE SILT FENCE SHALL BE INSTALLED AT A MINIMUM OF 10' FROM THE EDGE OF THE CONSTRUCTION SITE.
4. THE SILT FENCE SHALL BE MAINTAINED AT ALL TIMES TO ENSURE IT REMAINS EFFECTIVE.
5. THE SILT FENCE SHALL BE REMOVED IMMEDIATELY UPON COMPLETION OF THE PROJECT.

FLAT-BOTTOM TRENCH DETAIL

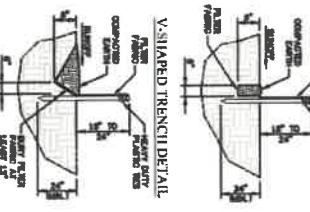

V-SHAPED TRENCH DETAIL

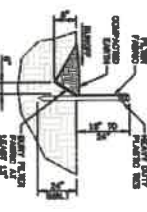

SEDIMENT TUBES - INSPECTION & MAINTENANCE

1. THE SILT FENCE SHALL BE INSPECTED WEEKLY TO ENSURE IT REMAINS EFFECTIVE.
2. THE SILT FENCE SHALL BE MAINTAINED AT ALL TIMES TO ENSURE IT REMAINS EFFECTIVE.
3. THE SILT FENCE SHALL BE REMOVED IMMEDIATELY UPON COMPLETION OF THE PROJECT.
4. THE SILT FENCE SHALL BE REINSTALLED IMMEDIATELY UPON COMPLETION OF THE PROJECT.
5. THE SILT FENCE SHALL BE MAINTAINED AT ALL TIMES TO ENSURE IT REMAINS EFFECTIVE.

SILT FENCE - POST REQUIREMENTS

1. THE SILT FENCE SHALL BE CONSTRUCTED USING 2x4 POSTS AND 1/2" FABRIC FILTER FABRIC.
2. THE SILT FENCE SHALL BE INSTALLED AT A MINIMUM OF 10' FROM THE EDGE OF THE CONSTRUCTION SITE.
3. THE SILT FENCE SHALL BE MAINTAINED AT ALL TIMES TO ENSURE IT REMAINS EFFECTIVE.
4. THE SILT FENCE SHALL BE REMOVED IMMEDIATELY UPON COMPLETION OF THE PROJECT.
5. THE SILT FENCE SHALL BE REINSTALLED IMMEDIATELY UPON COMPLETION OF THE PROJECT.

SILT FENCE - INSPECTION AND MAINTENANCE

1. THE SILT FENCE SHALL BE INSPECTED WEEKLY TO ENSURE IT REMAINS EFFECTIVE.
2. THE SILT FENCE SHALL BE MAINTAINED AT ALL TIMES TO ENSURE IT REMAINS EFFECTIVE.
3. THE SILT FENCE SHALL BE REMOVED IMMEDIATELY UPON COMPLETION OF THE PROJECT.
4. THE SILT FENCE SHALL BE REINSTALLED IMMEDIATELY UPON COMPLETION OF THE PROJECT.
5. THE SILT FENCE SHALL BE MAINTAINED AT ALL TIMES TO ENSURE IT REMAINS EFFECTIVE.

SEDIMENT TUBES

1. THE SILT FENCE SHALL BE CONSTRUCTED USING 2x4 POSTS AND 1/2" FABRIC FILTER FABRIC.
2. THE SILT FENCE SHALL BE INSTALLED AT A MINIMUM OF 10' FROM THE EDGE OF THE CONSTRUCTION SITE.
3. THE SILT FENCE SHALL BE MAINTAINED AT ALL TIMES TO ENSURE IT REMAINS EFFECTIVE.
4. THE SILT FENCE SHALL BE REMOVED IMMEDIATELY UPON COMPLETION OF THE PROJECT.
5. THE SILT FENCE SHALL BE REINSTALLED IMMEDIATELY UPON COMPLETION OF THE PROJECT.

SILT FENCE - FABRIC REQUIREMENTS

1. THE SILT FENCE SHALL BE CONSTRUCTED USING 2x4 POSTS AND 1/2" FABRIC FILTER FABRIC.
2. THE SILT FENCE SHALL BE INSTALLED AT A MINIMUM OF 10' FROM THE EDGE OF THE CONSTRUCTION SITE.
3. THE SILT FENCE SHALL BE MAINTAINED AT ALL TIMES TO ENSURE IT REMAINS EFFECTIVE.
4. THE SILT FENCE SHALL BE REMOVED IMMEDIATELY UPON COMPLETION OF THE PROJECT.
5. THE SILT FENCE SHALL BE REINSTALLED IMMEDIATELY UPON COMPLETION OF THE PROJECT.

SILT FENCE

1. THE SILT FENCE SHALL BE CONSTRUCTED USING 2x4 POSTS AND 1/2" FABRIC FILTER FABRIC.
2. THE SILT FENCE SHALL BE INSTALLED AT A MINIMUM OF 10' FROM THE EDGE OF THE CONSTRUCTION SITE.
3. THE SILT FENCE SHALL BE MAINTAINED AT ALL TIMES TO ENSURE IT REMAINS EFFECTIVE.
4. THE SILT FENCE SHALL BE REMOVED IMMEDIATELY UPON COMPLETION OF THE PROJECT.
5. THE SILT FENCE SHALL BE REINSTALLED IMMEDIATELY UPON COMPLETION OF THE PROJECT.



**CRANSTON**  
ENGINEERING

THUNDERBOLT CAREER AND TECHNOLOGY CENTER PAVING

DEMOLITION AND SWPPP DETAILS

SHEET  
02

JOB NO.	DATE	DRAWN	CHECKED	APPROVED
2021-0330	1/10/2022	PAG	MER	MER

- GENERAL NOTES:**
1. RESURFACING BEGINS AT THE EDGE OF THE INTERSECTING ROAD.
  2. REFERENCE DESCRIPTION OF WORK AND TYPICAL SECTIONS FOR CONSTRUCTION LIMITS ON EACH ROAD.
  3. MATCH EXISTING ROADWAY MARKINGS.

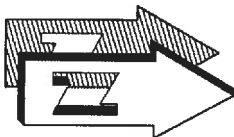
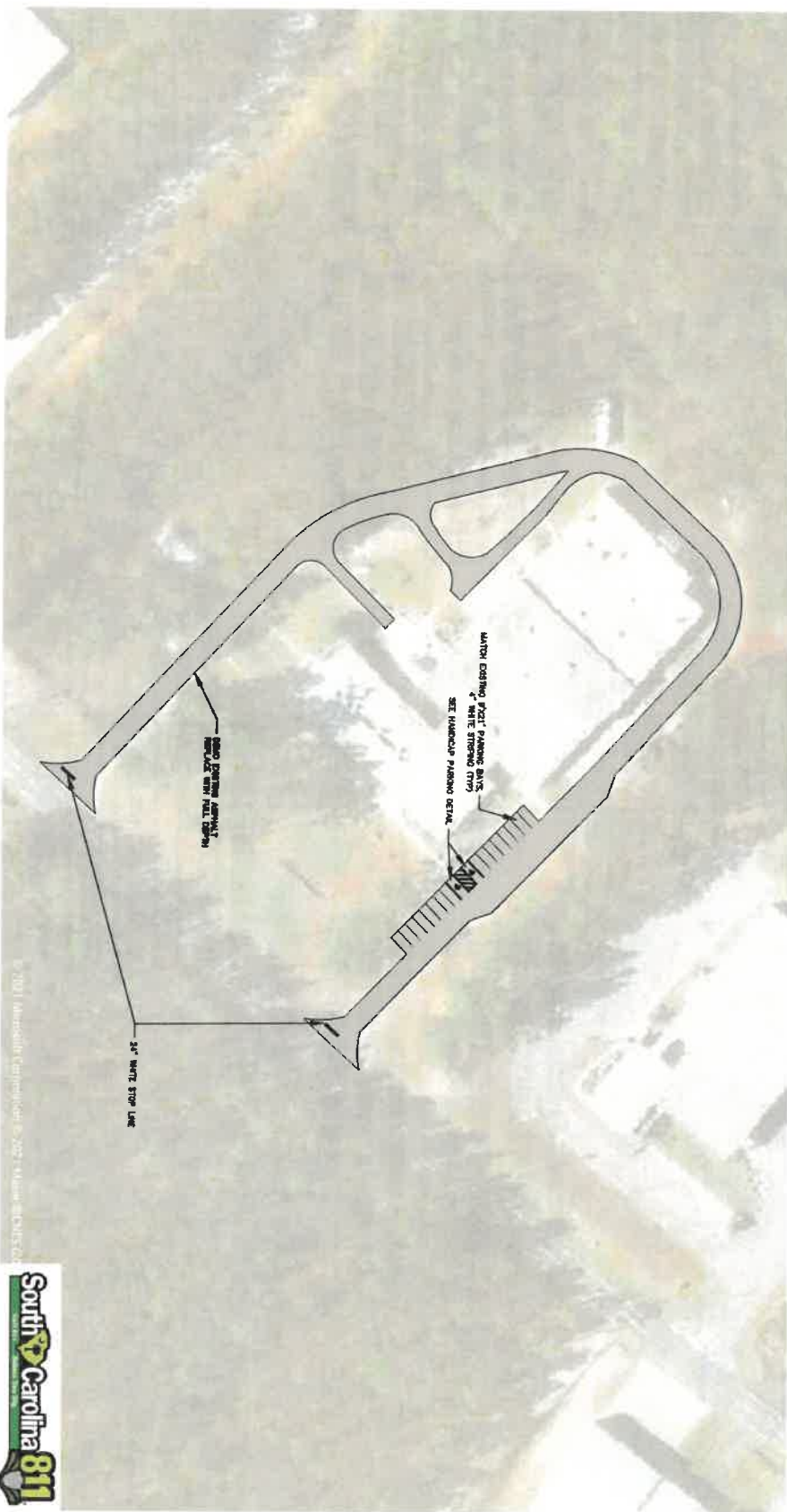

SHEET <b>03</b>	THUNDERBOLT CAREER AND TECHNOLOGY CENTER PAVING		
	IMPROVEMENT AND PAVEMENT MARKING PLAN		
JOB NO. 2021-0330	DATE 1/10/2022	DRAWN MES	CHECKED MER
		APPROVED MER	



**CRANSTON**  
ENGINEERING

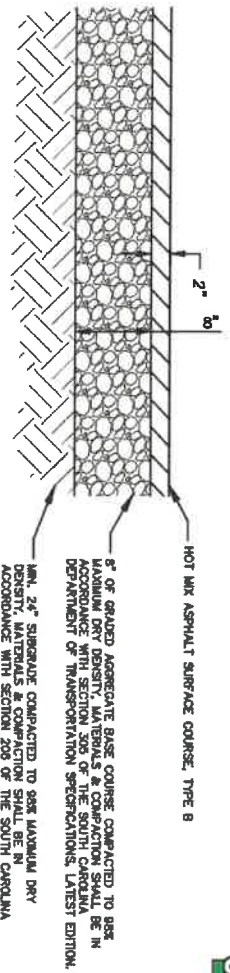

STANDARD DUTY ASPHALT PAVEMENT  
N.T.S.



HANDICAP SIGN - REFER TO MUTCD

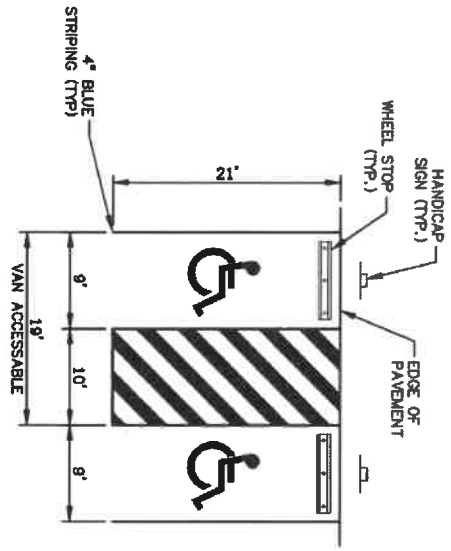

HANDICAP PARKING SPACE PLAN

HANDICAP PARKING  
N.T.S.



THUNDERBOLT CAREER AND TECHNOLOGY CENTER PAVING		JOB NO.		DATE	
CIVIL DETAILS		2021-0330		1/10/2022	
DRAWN	CHECKED	APPROVED			
PAG	MER	MER			



**CRANSTON**  
ENGINEERING

