



**CONTRACT DOCUMENTS AND
SPECIFICATIONS
FOR**

HALLSTROM FARMSTEAD PAVILIONS

BID NO. 2022002

PREPARED FOR
THE BOARD OF COUNTY COMMISSIONERS
INDIAN RIVER COUNTY, FLORIDA

JOSEPH E. FLESCHER, CHAIRMAN
PETER D. O'BRYAN, VICE-CHAIRMAN
COMMISSIONER SUSAN ADAMS
COMMISSIONER JOE EARMAN
COMMISSIONER LAURA MOSS

JASON E. BROWN, COUNTY ADMINISTRATOR
JEFFREY R. SMITH, CLERK OF COURT AND COMPTROLLER
DYLAN REINGOLD, COUNTY ATTORNEY
KEVIN KIRWIN, DIRECTOR OF PARKS & RECREATION

TABLE OF CONTENTS

Section No. Title

DIVISION 0 - BIDDING DOCUMENTS, CONTRACT FORMS, AND CONDITIONS OF THE CONTRACT

00001	Cover Sheet
00010	Table of Contents

BIDDING DOCUMENTS

00100	Advertisement for Bids
00200	Instructions to Bidders
00300	Bid Package Contents
00310	Bid Form & Itemized Bid Schedule
00430	Bid Bond
00452	Sworn Statement under Section 105.08, Indian River County Code, on Disclosure of Relationships
00456	Qualifications Questionnaire
00458	List of Subcontractors
00460	Certification Regarding Prohibition Against Contracting with Scrutinized Companies

CONTRACT FORMS

00510	Notice of Award
00520	Agreement
00550	Notice to Proceed
00610	Public Construction Bond
00620	Sample Certificate of Liability Insurance
00622	Contractor's Application for Payment
00630	Certificate of Substantial Completion
00632	Contractor's Final Certification of the Work
00634	Professional Surveyor and Mapper's Certification as to the Elevations and Locations of the Work

CONDITIONS OF THE CONTRACT

00700	EJCDC Standard General Conditions of the Construction Contract
00800	Supplementary Conditions to the General Conditions
00942	Change Order Form
00948	Work Change Directive

DIVISION 1 **GENERAL REQUIREMENTS**

DIVISION 2 **TECHNICAL PROVISIONS**

++ END OF TABLE OF CONTENTS ++

SECTION 00100 – Advertisement for Bids

BOARD OF COUNTY COMMISSIONERS

1801 27th Street
Vero Beach, Florida 32960

**ADVERTISEMENT FOR BIDS
INDIAN RIVER COUNTY**

Sealed bids will be received by Indian River County until **2:00 P.M. on Wednesday, November 10, 2021**. Each bid shall be submitted in a sealed envelope and shall bear the name and address of the bidder on the outside and the words "**Hallstrom Farmstead Pavilions and Bid No. 2022002**". Bids should be addressed to Purchasing Division, Room B1-301, 1800 27th Street, Vero Beach, Florida 32960. All bids will be opened publicly and read aloud at 2:00 P.M. All bids received after 2:00 P.M., on the day specified above, will not be accepted or considered.

INDIAN RIVER COUNTY BID NO. 2022002

PROJECT DESCRIPTION: Construction of two picnic pavilions within the Hallstrom Farmstead Conservation Area

All material and equipment furnished and all work performed shall be in strict accordance with the plans, specifications, and contract documents pertaining thereto. Detailed specifications are available at: www.demandstar.com or at www.ircgov.com/departments/budget/purchasing under "Current Solicitations".

All bidders shall submit one (1) original and one (1) copy of the Bid Proposal forms provided within the specifications. Please note that the questionnaire must be filled out completely including the financial statement. BID SECURITY must accompany each Bid, and must be in the form of an AIA Document A310 Bid Bond, properly executed by the Bidder and by a qualified surety, or a certified check or a cashier's check, drawn on any bank authorized to do business in the State of Florida. Bid Security must be in the sum of not less than **Five Percent (5%)** of the total amount of the bid, made payable to Indian River County Board of County Commissioners. In the event the Contract is awarded to the Bidder, Bidder will enter in a Contract with the County and furnish the required 100% Public Construction Bond and certificates of insurance within the timeframe set by the County. If Bidder fails to do so, the Bid Security shall be retained by the County as liquidated damages and not as penalty.

The County reserves the right to delay awarding of the Contract for a period of **ninety (90)** days after the bid opening, to waive informalities in any bid, or reject any or all bids in whole or in part with or without cause/or to accept the bid that, in its judgement, will serve the best interest of Indian River County, Florida. The County will not reimburse any Bidder for bid preparation costs.

A NON-MANDATORY Pre-Bid Conference will be held on **October 22, 2021 at 10:00 A.M.**, at the Hallstrom Farmstead Conservation Area located at 1273 Old Dixie Highway, Vero Beach, FL 32960. ATTENDANCE AT THIS CONFERENCE BY ALL BIDDERS IS HIGHLY ENCOURAGED.

INDIAN RIVER COUNTY

By: Jennifer Hyde
Purchasing Manager

For Publication on Demandstar and Vendor Registry October 8, 2021

*** * END OF SECTION * ***

SECTION 00200 – Instructions to Bidders**TABLE OF CONTENTS**

<u>Article No. - Title</u>	<u>Page</u>
SECTION 00200 – Instructions to Bidders	i
ARTICLE 1 - DEFINED TERMS	1
ARTICLE 2 - COPIES OF BIDDING DOCUMENTS	1
ARTICLE 3 - QUALIFICATIONS OF BIDDERS	1
ARTICLE 4 - EXAMINATION OF BIDDING DOCUMENTS, OTHER RELATED DATA, AND SITE	2
ARTICLE 5 - PRE-BID CONFERENCE	4
ARTICLE 6 - SITE AND OTHER AREAS	4
ARTICLE 7 - INTERPRETATIONS AND ADDENDA	4
ARTICLE 8 - BID SECURITY	5
ARTICLE 9 - CONTRACT TIMES	6
ARTICLE 10 - LIQUIDATED DAMAGES	6
ARTICLE 11 - SUBSTITUTE AND “OR-EQUAL” ITEMS	6
ARTICLE 12 - SUBCONTRACTORS, SUPPLIERS, AND OTHERS	6
ARTICLE 13 - PREPARATION OF BID	7
ARTICLE 14 - BASIS OF BID; EVALUATION OF BIDS	8
ARTICLE 15 - SUBMITTAL OF BID	8
ARTICLE 16 - MODIFICATION AND WITHDRAWAL OF BID	9
ARTICLE 17 - OPENING OF BIDS	9
ARTICLE 18 - BIDS TO REMAIN SUBJECT TO ACCEPTANCE	9
ARTICLE 19 - AWARD OF CONTRACT	9
ARTICLE 20 - CONTRACT SECURITY AND INSURANCE	11
ARTICLE 21 - SIGNING OF AGREEMENT	11

SECTION 00200 - Instructions to Bidders**TABLE OF ARTICLES (Alphabetical by Subject)**

Subject	Article
AWARD OF CONTRACT	19
BASIS OF BID; EVALUATION OF BIDS	14
BID SECURITY	8
BIDS TO REMAIN SUBJECT TO ACCEPTANCE	18
CONTRACT SECURITY AND INSURANCE	20
CONTRACT TIMES	9
COPIES OF BIDDING DOCUMENTS	2
DEFINED TERMS	1
EXAMINATION OF BIDDING DOCUMENTS, OTHER RELATED DATA, AND SITE	4
INTERPRETATIONS AND ADDENDA	7
LIQUIDATED DAMAGES	10
MODIFICATION AND WITHDRAWAL OF BID	16
OPENING OF BIDS	17
PRE-BID CONFERENCE	5
PREPARATION OF BID	13
QUALIFICATIONS OF BIDDERS	3
SIGNING OF AGREEMENT	21
SITE AND OTHER AREAS	6
SUBCONTRACTORS, SUPPLIERS, AND OTHERS	12
SUBMITTAL OF BID	15
SUBSTITUTE AND "OR-EQUAL" ITEMS	11

SECTION 00200 - Instructions to Bidders

ARTICLE 1 - DEFINED TERMS

1.01 Terms used in these Instructions to Bidders will have the meanings indicated in the General Conditions and Supplementary Conditions. Additional terms used in these Instructions to Bidders have the meanings indicated below which are applicable to both the singular and plural thereof:

- A. Bidder--The individual or entity who submits a Bid directly to OWNER.
- B. Issuing Office--The office from which the Bidding Documents are to be issued and where the bidding procedures are to be administered.
- C. Successful Bidder--The lowest responsible Bidder submitting a responsive Bid to whom OWNER (on the basis of OWNER's evaluation as hereinafter provided) makes an award.
- D. ENGINEER – References County Engineer or their designee.

ARTICLE 2 - COPIES OF BIDDING DOCUMENTS

- 2.01 Complete sets of the Bidding Documents in the number and for the deposit sum, if any, stated in the Advertisement for Bids or Invitation to Bid may be obtained from the Issuing Office.
- 2.02 Complete sets of Bidding Documents must be used in preparing Bids; neither OWNER nor ENGINEER assumes any responsibility for errors or misinterpretations resulting from the use of incomplete sets of Bidding Documents.
- 2.03 OWNER and ENGINEER in making copies of Bidding Documents available on the above terms do so only for the purpose of obtaining Bids for the Work and do not confer a license or grant for any other use.

ARTICLE 3 - QUALIFICATIONS OF BIDDERS

- 3.01 To demonstrate Bidder's qualifications to perform the Work, within five days of OWNER's request Bidder shall submit written evidence such as financial data, previous experience, present commitments, and such other data as may be called for below.
 - A. Bidder must have at least five years' experience in the construction of similar projects of this size and larger.
 - B. Bidder must have successfully constructed, as prime CONTRACTOR, at least three projects similar in scope to this project.
 - C. Bidder must have good recommendations from at least three clients similar to the OWNER.
 - D. The Bidder's superintendent and assistants must be qualified and experienced in similar projects in all categories.
 - E. Bidder must be able to provide evidence of authority to conduct business in the jurisdiction in which the project is located.
 - F. Bidder must hold a current registration as a General Contractor in the State of Florida.

- 3.02 Each bid must contain evidence of Bidder's qualification to do business in the state where the Project is located or covenant to obtain such qualification prior to award of the contract.
- 3.03 The OWNER reserves the right to reject bids from Bidders that are unable to meet the listed required qualifications.
- 3.04 Bidder must be registered with and use, at their sole expense, the Department of Homeland Security's E-Verify system (www.e-verify.gov) to confirm the employment eligibility of all newly hired employees, as required by Section 448.095, F.S. Owner, contractor, and subcontractors may not enter into a contract unless each party to the contract registers with and uses the E-Verify system. Contractor is responsible for obtaining proof of E-Verify registration for all subcontractors. This requirement applies to any provider of services or goods.

ARTICLE 4 - EXAMINATION OF BIDDING DOCUMENTS, OTHER RELATED DATA, AND SITE

4.01 Subsurface and Physical Conditions

A. The Supplementary Conditions identify:

1. Those reports of explorations and tests of subsurface conditions at or contiguous to the Site that Engineer has used in preparing the Bidding Documents.

2. Those drawings of physical conditions in or relating to existing surface and subsurface structures at or contiguous to the Site (except Underground Facilities) that ENGINEER has used in preparing the Bidding Documents.

B. Copies of reports and drawings referenced in paragraph 4.01.A will be made available by OWNER to any Bidder on request. Those reports and drawings are not part of the Contract Documents, but the "technical data" contained therein upon which Bidder is entitled to rely as provided in paragraph 4.02 of the General Conditions has been identified and established in paragraph 4.02 of the Supplementary Conditions. Bidder is responsible for any interpretation or conclusion Bidder draws from any "technical data" or any other data, interpretations, opinions or information contained in such reports or shown or indicated in such drawings.

4.02 Underground Facilities

A. Information and data shown or indicated in the Bidding Documents with respect to existing Underground Facilities at or contiguous to the Site is based upon information and data furnished to OWNER and ENGINEER by OWNERS of such Underground Facilities, including OWNER, or others.

4.03 Hazardous Environmental Condition

A. The Supplementary Conditions identify those reports and drawings relating to a Hazardous Environmental Condition identified at the Site, if any, that ENGINEER has used in preparing the Bidding Documents.

B. Copies of reports and drawings referenced in paragraph 4.03.A will be made available by OWNER to any Bidder on request. Those reports and drawings are not part of the Contract

Documents, but the “technical data” contained therein upon which Bidder is entitled to rely as provided in paragraph 4.06 of the General Conditions. Bidder is responsible for any interpretation or conclusion Bidder draws from any “technical data” or any other data, interpretations, opinions, or information contained in such reports or shown or indicated in such drawings.

4.04 Provisions concerning responsibilities for the adequacy of data furnished to prospective Bidders with respect to subsurface conditions, other physical conditions and Underground Facilities, and possible changes in the Bidding Documents due to differing or unanticipated conditions appear in paragraphs 4.02, 4.03, and 4.04 of the General Conditions. Provisions concerning responsibilities for the adequacy of data furnished to prospective Bidders with respect to a Hazardous Environmental Condition at the Site, if any, and possible changes in the Contract Documents due to any Hazardous Environmental Condition uncovered or revealed at the Site which was not shown or indicated in the Drawings or Specifications or identified in the Contract Documents to be within the scope of the Work appear in paragraph 4.06 of the General Conditions.

4.05 Upon a request directed to the Purchasing Division (purchasing@ircgov.com or (772) 226-1416), OWNER will provide Bidder access to the Site to conduct such examinations, investigations, explorations, tests, and studies as Bidder deems necessary for submission of a Bid. Bidder shall fill all holes and clean up and restore the Site to its former condition upon completion of such explorations, investigations, tests, and studies.

4.06 “This paragraph has been deleted intentionally”

4.07 It is the responsibility of each Bidder before submitting a Bid to:

A. examine and carefully study the Bidding Documents, including any Addenda and the other related data identified in the Bidding Documents;

B. VISIT THE SITE AND BECOME FAMILIAR WITH AND SATISFY BIDDER AS TO THE GENERAL, LOCAL, AND SITE CONDITIONS THAT MAY AFFECT COST, PROGRESS, AND PERFORMANCE OF THE WORK;

C. become familiar with and satisfy Bidder as to all federal, state, and local Laws and Regulations that may affect cost, progress, or performance of the Work;

D. carefully study all reports of explorations and tests of subsurface conditions at or contiguous to the Site and all drawings of physical conditions in or relating to existing surface or subsurface structures at or contiguous to the Site (except Underground Facilities) which have been identified in the Supplementary Conditions as provided in paragraph 4.02 of the General Conditions, and carefully study all reports and drawings of a Hazardous Environmental Condition, if any, at the Site which have been identified in the Supplementary Conditions as provided in paragraph 4.06 of the General Conditions;

E. obtain and carefully study (or assume responsibility for doing so) all additional or supplementary examinations, investigations, explorations, tests, studies, and data concerning conditions (overhead, surface, subsurface, and Underground Facilities) at or contiguous to the Site which may affect cost, progress, or performance of the Work or which relate to any aspect of the means, methods, techniques, sequences, and procedures of construction to be employed by Bidder, including any specific means, methods, techniques, sequences, and procedures of construction expressly required by the Bidding Documents, and safety precautions and programs incident thereto;

F. agree at the time of submitting its Bid that no further examinations, investigations, explorations, tests, studies, or data are necessary for the determination of its Bid for performance of the Work at the price bid and within the times and in accordance with the other terms and conditions of the Bidding Documents;

G. become aware of the general nature of the work to be performed by OWNER and others at the Site that relates to the Work as indicated in the Bidding Documents;

H. correlate the information known to Bidder, information and observations obtained from visits to the Site, reports and drawings identified in the Bidding Documents, and all additional examinations, investigations, explorations, tests, studies, and data with the Bidding Documents;

I. promptly give ENGINEER written notice of all conflicts, errors, ambiguities, or discrepancies that Bidder discovers in the Bidding Documents and confirm that the written resolution thereof by ENGINEER is acceptable to Bidder; and

J. determine that the Bidding Documents are generally sufficient to indicate and convey understanding of all terms and conditions for the performance of the Work.

4.08 The submission of a Bid will constitute an incontrovertible representation by Bidder that Bidder has complied with every requirement of this Article 4, that without exception the Bid is premised upon performing and furnishing the Work required by the Bidding Documents and applying any specific means, methods, techniques, sequences, and procedures of construction that may be shown or indicated or expressly required by the Bidding Documents, that Bidder has given ENGINEER written notice of all conflicts, errors, ambiguities, and discrepancies that Bidder has discovered in the Bidding Documents and the written resolutions thereof by ENGINEER are acceptable to Bidder, and that the Bidding Documents are generally sufficient to indicate and convey understanding of all terms and conditions for performing and furnishing the Work.

ARTICLE 5 - PRE-BID CONFERENCE

5.01 The date, time, and location for the NON-MANDATORY Pre-Bid conference, if any, is specified in the Advertisement for Bids. Representatives of OWNER and ENGINEER will be present to discuss the Project. Bidders are not required, but are highly encouraged, to attend and participate in the conference. ENGINEER will transmit to all prospective Bidders of record such Addenda as ENGINEER considers necessary in response to questions arising at the conference. Oral statements may not be relied upon and will not be binding or legally effective.

ARTICLE 6 - SITE AND OTHER AREAS

6.01 The Site is identified in the Bidding Documents. All additional lands and access thereto required for temporary construction facilities, construction equipment, or storage of materials and equipment to be incorporated in the Work are to be obtained and paid for by CONTRACTOR. Easements for permanent structures or permanent changes in existing facilities are to be obtained and paid for by OWNER unless otherwise provided in the Bidding Documents.

ARTICLE 7 - INTERPRETATIONS AND ADDENDA

7.01 **CONE OF SILENCE.** Potential bidders and their agents shall not communicate in any way with the Board of County Commissioners, County Administrator or any County staff other than Purchasing personnel in reference or relation to this solicitation. This restriction shall be effective from the time of bid advertisement until the Board of County Commissioners meets to authorize award. Such communication may result in disqualification.

7.02 All questions about the meaning or intent of the Bidding Documents are to be submitted to PURCHASING (purchasing@ircgov.com) in writing. Interpretations or clarifications considered necessary by ENGINEER in response to such questions will be issued by Addenda mailed or delivered to all parties through the Issuing Office as having received the Bidding Documents. Questions received less than ten days prior to the date for opening of Bids may not be answered. Only questions answered by Addenda will be binding. Oral and other interpretations or clarifications will be without legal effect.

7.03 Addenda may be issued to clarify, correct, or change the Bidding Documents as deemed advisable by OWNER or ENGINEER.

ARTICLE 8 - BID SECURITY

8.01 Any Each Bid must be accompanied by Bid Security made payable to OWNER in the amount of five percent of the Bidder's maximum base bid price and in the form of a certified check; cashier's check; or an AIA Document A310 Bid Bond issued by a surety meeting the requirements of Paragraph 5.01 of the General Conditions. The Bid Bond shall be executed by such sureties as are named in the current list of "Companies Holding Certificates of Authority as Acceptable Sureties on Federal Bonds and as Acceptable Reinsuring Companies" as published in Circular 570 (amended) by the Financial Management Service, Surety Bond Branch, U.S. Department of the Treasury. The Surety must be authorized to issue surety bonds in Florida. The Bidder shall require the attorney-in-fact who executes any Bond, to affix to each a current certified copy of their Power of Attorney, reflecting such person's authority as Power of Attorney in the State of Florida. Further, at the time of execution of the Contract, the Successful Bidder shall for all Bonds, provide a copy of the Surety's current valid Certificate of Authority issued by the United States Department of the Treasury under 31 United States Code sections 9304-9308. The Surety shall also meet the requirements of paragraphs 5.01 and 5.02 of the General Conditions.

8.02 The Bid security of the Successful Bidder will be retained until such Bidder has executed the Contract Documents, furnished the required contract security and met the other conditions of the Notice of Award, whereupon the Bid security will be returned. If the Successful Bidder fails to execute and deliver the Contract Documents and furnish the required contract security within 15 days after the Notice of Award, OWNER may annul the Notice of Award and the Bid security of that Bidder will be retained by the owner. The Bid Security of other Bidders whom OWNER believes to have a reasonable chance of receiving the award may be retained by OWNER until the earlier of seven days after the Effective Date of the Agreement or 91 days after the Bid opening, whereupon Bid Security furnished by such Bidders will be returned.

8.03 Bid Security of other Bidders whom OWNER believes do not have a reasonable chance of receiving the award will be returned within seven days after the Bid opening.

ARTICLE 9 - CONTRACT TIMES

9.01 The number of calendar days within which, or the dates by which, the Work is to be (a) Substantially Completed and (b) also completed and ready for final payment are set forth in the Agreement.

ARTICLE 10 - LIQUIDATED DAMAGES

10.01 Provisions for liquidated damages, if any, are set forth in the Agreement.

ARTICLE 11 - SUBSTITUTE AND "OR-EQUAL" ITEMS

11.01 The Contract, if awarded, will be on the basis of materials and equipment specified or described in the Bidding Documents without consideration of possible substitute or "or-equal" items. Whenever it is specified or described in the Bidding Documents that a substitute or "or-equal" item of material or equipment may be furnished or used by CONTRACTOR if acceptable to ENGINEER, application for such acceptance will not be considered by ENGINEER until after the Effective Date of the Agreement. The procedure for submission of any such application by CONTRACTOR and consideration by ENGINEER is set forth in the General Conditions and may be supplemented in the General Requirements.

ARTICLE 12 - SUBCONTRACTORS, SUPPLIERS, AND OTHERS

12.01 If the Supplementary Conditions require the identity of certain Subcontractors, Suppliers, individuals, or entities to be submitted to OWNER in advance of a specified date prior to the Effective Date of the Agreement, the apparent Successful Bidder, and any other Bidder so requested, shall within five days after Bid opening, submit to OWNER a list of all such Subcontractors, Suppliers, individuals, or entities proposed for those portions of the Work for which such identification is required. Such list shall be accompanied by an experience statement with pertinent information regarding similar projects and other evidence of qualification for each such Subcontractor, Supplier, individual, or entity if requested by OWNER. If OWNER or ENGINEER, after due investigation, has reasonable objection to any proposed Subcontractor, Supplier, individual, or entity, OWNER may, before the Notice of Award is given, request apparent Successful Bidder to submit a substitute, without an increase in the Bid.

12.02 If apparent Successful Bidder declines to make any such substitution, OWNER may award the Contract to the next lowest Bidder that proposes to use acceptable Subcontractors, Suppliers, individuals, or entities. Declining to make requested substitutions will not constitute grounds for forfeiture of the Bid security of any Bidder. Any Subcontractor, Supplier, individual, or entity so listed and against which OWNER or ENGINEER makes no written objection prior to the giving of the Notice of Award will be deemed acceptable to OWNER and ENGINEER subject to revocation of such acceptance after the Effective Date of the Agreement as provided in paragraph 6.06 of the General Conditions.

12.03 CONTRACTOR shall not be required to employ any Subcontractor, Supplier, individual, or entity against whom CONTRACTOR has reasonable objection.

ARTICLE 13 - PREPARATION OF BID

13.01 The Bid form is included with the Bidding Documents. Only the bid form provided by OWNER is acceptable (Bidders are not to recreate the bid form). **Bids not submitted on the bid form(s) shall be rejected, as will bids submitted on rewritten or recreated bid forms.**

13.02 All blanks on the Bid form shall be completed by printing in ink or by typewriter and the Bid signed. A Bid price shall be indicated for each section, Bid item, alternative, adjustment unit price item, and unit price item listed therein, or the words "No Bid," "No Change," or "Not Applicable" entered.

13.03 A Bid by a corporation shall be executed in the corporate name by the president or a vice-president or other corporate officer accompanied by evidence of authority to sign. The corporate seal shall be affixed and attested by the secretary or an assistant secretary. The corporate address and state of incorporation shall be shown below the signature.

13.04 A Bid by a partnership shall be executed in the partnership name and signed by a partner (whose title must appear under the signature), accompanied by evidence of authority to sign. The official address of the partnership shall be shown below the signature.

13.05 A Bid by a limited liability company shall be executed in the name of the firm by a member and accompanied by evidence of authority to sign. The state of formation of the firm and the official address of the firm must be shown below the signature.

13.06 A Bid by an individual shall show the Bidder's name and official address.

13.07 A Bid by a joint venture shall be executed by each joint venturor in the manner indicated on the Bid form. The official address of the joint venture must be shown below the signature.

13.08 All names shall be typed or printed in ink below the signatures.

13.09 The Bid shall contain an acknowledgment of receipt of all Addenda, the numbers of which shall be filled in on the Bid form.

13.10 The address and telephone number for communications regarding the Bid shall be shown.

13.11 The Bid shall contain evidence of Bidder's authority and qualification to do business in the state where the Project is located or covenant to obtain such qualification prior to award of the Contract. Bidder's state contractor license number or county registration number for the state or county of the Project, if any, shall also be shown on the Bid form.

13.12 All supporting information requested in the Bid Form must be furnished. Do not leave any questions or requests unanswered.

13.13 In accordance with Florida Statutes Section 218.80, the "Public Bid Disclosure Act", Indian River County as OWNER is obligated to disclose all license, permit, impact, or inspection fees that are payable to Indian River County in connection with the construction of the Work by the accepted bidder. All permit, impact, or inspection fees payable to Indian River County in connection with the work on this County project will be paid by Indian River County, with the exception of re-inspection fees. The Bidder shall not include ANY PERMIT, IMPACT, NOR INSPECTION FEES payable to **Indian River County** in the bid. A copy of the IRC Building

Department Fee Schedule has been included in Appendix 5.

13.14 CONTRACTOR shall furnish all labor, materials, equipment and incidentals necessary to perform additional work not covered on the Contract Drawings. The **FORCE ACCOUNT** is intended as a contingency for unforeseen work. Lump sum amount for **FORCE ACCOUNT** work is included in the bid schedule. The value of force account work will be determined in accordance with Article 12 of the General Conditions.

ARTICLE 14 - BASIS OF BID; EVALUATION OF BIDS

14.01 Unit Price

A. Bidders shall submit a Bid on a unit price basis for each item of Work listed in the Bid schedule. Omission of one or more unit prices shall disqualify the bid.

B. The total of all estimated prices will be determined as the sum of the products of the estimated quantity of each item and the unit price Bid for the item. The final quantities and Contract Price will be determined in accordance with paragraph 11.03 of the General Conditions.

C. Discrepancies between the multiplication of units of Work and unit prices will be resolved in favor of the unit prices. Discrepancies between the indicated sum of any column of figures and the correct sum thereof will be resolved in favor of the correct sum. Discrepancies between words and figures will be resolved in favor of the words.

14.02 The Bid price shall include such amounts as the Bidder deems proper for overhead and profit on account of cash allowances, if any, named in the Contract Documents as provided in paragraph 11.02 of the General Conditions.

14.03 The Bidder's attention is called to the fact that any estimate of quantities of work to be done and materials to be furnished under the Specifications as shown on the Bid Schedule, or elsewhere, is approximate only and not guaranteed. The OWNER does not assume any responsibility that the final quantities shall remain in strict accordance with the estimated quantities, nor shall the Bidder plead misunderstanding or deception because of such estimate of quantities or of the character, location of the work, or other conditions pertaining thereto.

ARTICLE 15 - SUBMITTAL OF BID

15.01 The Bid form is to be completed and submitted with the Bid security and the following data:

- A. Sworn Statement under Section 105.08, Indian River County Code, on Disclosure of Relationships.
- B. Qualifications Questionnaire.
- C. List of Subcontractors.
- D. Certification Regarding Prohibition Against Contracting with Scrutinized Companies

15.02 A Bid shall be submitted no later than the date and time prescribed and at the place indicated in the advertisement or invitation to Bid and shall be enclosed in an opaque sealed envelope plainly

marked with the Project Title and Bid Number (and, if applicable, the designated portion of the Project for which the Bid is submitted), Bid Number, the name and address of Bidder, and shall be accompanied by the Bid security and other required documents. If mail or other delivery system sends a Bid, the sealed envelope containing the Bid shall be enclosed in a separate envelope plainly marked on the outside with the notation "BID ENCLOSED." A mailed Bid shall be addressed to Indian River County, Purchasing Division, 1800 27th Street, Vero Beach, Florida, 32960.

ARTICLE 16 - MODIFICATION AND WITHDRAWAL OF BID

16.01 A Bid may be modified or withdrawn by an appropriate document duly executed in the manner that a Bid must be executed and delivered to the place where Bids are to be submitted prior to the date and time for the opening of Bids.

16.02 If within 24 hours after Bids are opened any Bidder files a duly signed written notice with OWNER and promptly thereafter demonstrates to the reasonable satisfaction of OWNER that there was a material and substantial mistake in the preparation of its Bid, that Bidder may withdraw its Bid, and the Bid security will be returned. Thereafter, if the Work is rebid, that Bidder will be disqualified from further bidding on the Work.

ARTICLE 17 - OPENING OF BIDS

17.01 Bids will be opened at the time and place indicated in the advertisement or invitation to Bid and, unless obviously non-responsive, read aloud publicly. An abstract of the amounts of the base Bids and major alternates, if any, will be made available to Bidders after the opening of Bids.

ARTICLE 18 - BIDS TO REMAIN SUBJECT TO ACCEPTANCE

18.01 All Bids will remain subject to acceptance for the period of time stated in the Bid Form, but OWNER may, in its sole discretion, release any Bid and return the Bid security prior to the end of this period.

ARTICLE 19 - AWARD OF CONTRACT

19.01 OWNER reserves the right to reject any or all Bids, including without limitation, nonconforming, nonresponsive, unbalanced, or conditional Bids. OWNER further reserves the right to reject the Bid of any Bidder whom it finds, after reasonable inquiry and evaluation, to be non-responsive. OWNER may also reject the Bid of any Bidder if OWNER believes that it would not be in the best interest of the Project to make an award to that Bidder. OWNER also reserves the right to waive all technicalities and informalities not involving price, time, or changes in the work and to negotiate contract terms with the Successful Bidder. The County will not reimburse any Bidder for bid preparation costs. Owner reserves the right to cancel the award of any Contract at any time before the execution of such Contract by all parties without any liability to the Owner. For and in consideration of the Owner considering Bids submitted, the Bidder, by submitting its Bid, expressly waives any claim to damages, of any kind whatsoever, in the event the Owner exercises its right to cancel the award in accordance herewith.

19.02 More than one Bid for the same Work from an individual or entity under the same or different names will not be considered. Reasonable grounds for believing that any Bidder has an interest in more than one Bid for the Work may be cause for disqualification of that Bidder and the rejection of all Bids in which that Bidder has an interest.

19.03 In evaluating Bids, OWNER will consider whether or not the Bids comply with the prescribed requirements, and such alternates, unit prices and other data, as may be requested in the Bid Form or prior to the Notice of Award.

19.04 In evaluating Bidders, OWNER will consider the qualifications of Bidders and may consider the qualifications and experience of Subcontractors, Suppliers, and other individuals or entities proposed for those portions of the Work for which the identity of Subcontractors, Suppliers, and other individuals or entities must be submitted as provided in the Supplementary Conditions.

19.05 OWNER may conduct such investigations as OWNER deems necessary to establish the responsibility, qualifications, and financial ability of Bidders, proposed Subcontractors, Suppliers, individuals, or entities to perform the Work in accordance with the Contract Documents.

19.06 If the Contract is to be awarded, OWNER will award the Contract to the Bidder whose Bid is in the best interests of the Project.

19.07 OWNER has no local ordinance or preferences, as set forth in FS 255.0991 (2) in place, therefore no preference prohibited by that section will be considered in the acceptance, review or award of this bid.

19.08 Any actual or prospective bidder or proposer who is aggrieved in connection with the bidding and/or selection process may protest to the OWNER's Purchasing Manager. The protest shall be submitted in writing to the Purchasing Manager within seven (7) calendar days after the bidder or proposer knows or should have known of the facts giving rise to the protest.

19.09 CONTRACTOR certifies that it and its related entities as defined by Florida law are not on the Scrutinized Companies that Boycott Israel List, created pursuant to s. 215.4725 of the Florida Statutes, and are not engaged in a boycott of Israel. In addition, if this agreement is for goods or services of one million dollars or more, CONTRACTOR certifies that it and its related entities as defined above by Florida law are not on the Scrutinized Companies with Activities in Sudan List or the Scrutinized Companies with Activities in the Iran Petroleum Energy Sector List, created pursuant to Section 215.473 of the Florida Statutes and are not engaged in business operations in Cuba or Syria.

OWNER may terminate this Contract if CONTRACTOR is found to have submitted a false certification as provided under section 287.135(5), Florida Statutes, been placed on the Scrutinized Companies with Activities in Sudan List or the Scrutinized Companies with Activities in the Iran Petroleum Energy Sector List, or been engaged in business operations in Cuba or Syria, as defined by section 287.135, Florida Statutes.

OWNER may terminate this Contract if CONTRACTOR, including all wholly owned subsidiaries, majority-owned subsidiaries, and parent companies, that exist for the purpose of making profit, is found to have been placed on the Scrutinized Companies that Boycott Israel List or is engaged in a boycott of Israel as set forth in section 215.4725, Florida Statutes.

Accordingly, firms responding to this solicitation shall return with their response an executed copy of the attached "Certification Regarding Prohibition Against Contracting With Scrutinized Companies." Failure to return this executed form with submitted bid/proposal/statement of

qualifications will result in the response being deemed non-responsive and eliminated from consideration.

ARTICLE 20 - CONTRACT SECURITY AND INSURANCE

20.01 Article 5 of the General Conditions, as may be modified by the Supplementary Conditions, sets forth OWNER's requirements as to Public Construction Bond and insurance. When the Successful Bidder delivers the executed Agreement to OWNER, it must be accompanied by the required insurance certificate(s) and Bond, unless the Bond has been waived due to the total contract being less than \$100,000.

ARTICLE 21 - SIGNING OF AGREEMENT

21.01 When OWNER gives a Notice of Award to the Successful Bidder, it shall be accompanied by the required number of unsigned counterparts of the Agreement with the other Contract Documents which are identified in the Agreement as attached thereto. Within fifteen (15) days thereafter, Successful Bidder shall sign and deliver the required number of counterparts of the Agreement and attached documents to OWNER.

21.02 OWNER shall return one fully signed counterpart to Successful Bidder.

21.03 Should Bidder to whom the Contract has been awarded refuse or fail to complete the requirements of Article 21.01 above, the additional time in calendar days, required to correctly complete the documents will be deducted, in equal amount, from the Contract time. Or, the OWNER may elect to revoke the Award and the OWNER shall hold the Bid Bond for consequential damages incurred, and the Contract may be awarded as the OWNER desires.

**** END OF SECTION ****

SECTION 00200 – Instructions to Bidders**TABLE OF CONTENTS**

<u>Article No. - Title</u>	<u>Page</u>
SECTION 00200 – Instructions to Bidders	i
ARTICLE 1 - DEFINED TERMS	1
ARTICLE 2 - COPIES OF BIDDING DOCUMENTS	1
ARTICLE 3 - QUALIFICATIONS OF BIDDERS	1
ARTICLE 4 - EXAMINATION OF BIDDING DOCUMENTS, OTHER RELATED DATA, AND SITE	2
ARTICLE 5 - PRE-BID CONFERENCE	4
ARTICLE 6 - SITE AND OTHER AREAS	4
ARTICLE 7 - INTERPRETATIONS AND ADDENDA	4
ARTICLE 8 - BID SECURITY	5
ARTICLE 9 - CONTRACT TIMES	6
ARTICLE 10 - LIQUIDATED DAMAGES	6
ARTICLE 11 - SUBSTITUTE AND “OR-EQUAL” ITEMS	6
ARTICLE 12 - SUBCONTRACTORS, SUPPLIERS, AND OTHERS	6
ARTICLE 13 - PREPARATION OF BID	7
ARTICLE 14 - BASIS OF BID; EVALUATION OF BIDS	8
ARTICLE 15 - SUBMITTAL OF BID	8
ARTICLE 16 - MODIFICATION AND WITHDRAWAL OF BID	9
ARTICLE 17 - OPENING OF BIDS	9
ARTICLE 18 - BIDS TO REMAIN SUBJECT TO ACCEPTANCE	9
ARTICLE 19 - AWARD OF CONTRACT	9
ARTICLE 20 - CONTRACT SECURITY AND INSURANCE	11
ARTICLE 21 - SIGNING OF AGREEMENT	11

SECTION 00200 - Instructions to Bidders**TABLE OF ARTICLES (Alphabetical by Subject)**

Subject	Article
AWARD OF CONTRACT	19
BASIS OF BID; EVALUATION OF BIDS	14
BID SECURITY	8
BIDS TO REMAIN SUBJECT TO ACCEPTANCE	18
CONTRACT SECURITY AND INSURANCE	20
CONTRACT TIMES	9
COPIES OF BIDDING DOCUMENTS	2
DEFINED TERMS	1
EXAMINATION OF BIDDING DOCUMENTS, OTHER RELATED DATA, AND SITE	4
INTERPRETATIONS AND ADDENDA	7
LIQUIDATED DAMAGES	10
MODIFICATION AND WITHDRAWAL OF BID	16
OPENING OF BIDS	17
PRE-BID CONFERENCE	5
PREPARATION OF BID	13
QUALIFICATIONS OF BIDDERS	3
SIGNING OF AGREEMENT	21
SITE AND OTHER AREAS	6
SUBCONTRACTORS, SUPPLIERS, AND OTHERS	12
SUBMITTAL OF BID	15
SUBSTITUTE AND "OR-EQUAL" ITEMS	11

SECTION 00200 - Instructions to Bidders

ARTICLE 1 - DEFINED TERMS

1.01 Terms used in these Instructions to Bidders will have the meanings indicated in the General Conditions and Supplementary Conditions. Additional terms used in these Instructions to Bidders have the meanings indicated below which are applicable to both the singular and plural thereof:

- A. Bidder--The individual or entity who submits a Bid directly to OWNER.
- B. Issuing Office--The office from which the Bidding Documents are to be issued and where the bidding procedures are to be administered.
- C. Successful Bidder--The lowest responsible Bidder submitting a responsive Bid to whom OWNER (on the basis of OWNER's evaluation as hereinafter provided) makes an award.
- D. ENGINEER – References County Engineer or their designee.

ARTICLE 2 - COPIES OF BIDDING DOCUMENTS

- 2.01 Complete sets of the Bidding Documents in the number and for the deposit sum, if any, stated in the Advertisement for Bids or Invitation to Bid may be obtained from the Issuing Office.
- 2.02 Complete sets of Bidding Documents must be used in preparing Bids; neither OWNER nor ENGINEER assumes any responsibility for errors or misinterpretations resulting from the use of incomplete sets of Bidding Documents.
- 2.03 OWNER and ENGINEER in making copies of Bidding Documents available on the above terms do so only for the purpose of obtaining Bids for the Work and do not confer a license or grant for any other use.

ARTICLE 3 - QUALIFICATIONS OF BIDDERS

- 3.01 To demonstrate Bidder's qualifications to perform the Work, within five days of OWNER's request Bidder shall submit written evidence such as financial data, previous experience, present commitments, and such other data as may be called for below.
 - A. Bidder must have at least five years' experience in the construction of similar projects of this size and larger.
 - B. Bidder must have successfully constructed, as prime CONTRACTOR, at least three projects similar in scope to this project.
 - C. Bidder must have good recommendations from at least three clients similar to the OWNER.
 - D. The Bidder's superintendent and assistants must be qualified and experienced in similar projects in all categories.
 - E. Bidder must be able to provide evidence of authority to conduct business in the jurisdiction in which the project is located.
 - F. Bidder must hold a current registration as a General Contractor in the State of Florida.

- 3.02 Each bid must contain evidence of Bidder's qualification to do business in the state where the Project is located or covenant to obtain such qualification prior to award of the contract.
- 3.03 The OWNER reserves the right to reject bids from Bidders that are unable to meet the listed required qualifications.
- 3.04 Bidder must be registered with and use, at their sole expense, the Department of Homeland Security's E-Verify system (www.e-verify.gov) to confirm the employment eligibility of all newly hired employees, as required by Section 448.095, F.S. Owner, contractor, and subcontractors may not enter into a contract unless each party to the contract registers with and uses the E-Verify system. Contractor is responsible for obtaining proof of E-Verify registration for all subcontractors. This requirement applies to any provider of services or goods.

ARTICLE 4 - EXAMINATION OF BIDDING DOCUMENTS, OTHER RELATED DATA, AND SITE

4.01 Subsurface and Physical Conditions

A. The Supplementary Conditions identify:

1. Those reports of explorations and tests of subsurface conditions at or contiguous to the Site that Engineer has used in preparing the Bidding Documents.
2. Those drawings of physical conditions in or relating to existing surface and subsurface structures at or contiguous to the Site (except Underground Facilities) that ENGINEER has used in preparing the Bidding Documents.

B. Copies of reports and drawings referenced in paragraph 4.01.A will be made available by OWNER to any Bidder on request. Those reports and drawings are not part of the Contract Documents, but the "technical data" contained therein upon which Bidder is entitled to rely as provided in paragraph 4.02 of the General Conditions has been identified and established in paragraph 4.02 of the Supplementary Conditions. Bidder is responsible for any interpretation or conclusion Bidder draws from any "technical data" or any other data, interpretations, opinions or information contained in such reports or shown or indicated in such drawings.

4.02 Underground Facilities

A. Information and data shown or indicated in the Bidding Documents with respect to existing Underground Facilities at or contiguous to the Site is based upon information and data furnished to OWNER and ENGINEER by OWNERS of such Underground Facilities, including OWNER, or others.

4.03 Hazardous Environmental Condition

A. The Supplementary Conditions identify those reports and drawings relating to a Hazardous Environmental Condition identified at the Site, if any, that ENGINEER has used in preparing the Bidding Documents.

B. Copies of reports and drawings referenced in paragraph 4.03.A will be made available by OWNER to any Bidder on request. Those reports and drawings are not part of the Contract

Documents, but the “technical data” contained therein upon which Bidder is entitled to rely as provided in paragraph 4.06 of the General Conditions. Bidder is responsible for any interpretation or conclusion Bidder draws from any “technical data” or any other data, interpretations, opinions, or information contained in such reports or shown or indicated in such drawings.

4.04 Provisions concerning responsibilities for the adequacy of data furnished to prospective Bidders with respect to subsurface conditions, other physical conditions and Underground Facilities, and possible changes in the Bidding Documents due to differing or unanticipated conditions appear in paragraphs 4.02, 4.03, and 4.04 of the General Conditions. Provisions concerning responsibilities for the adequacy of data furnished to prospective Bidders with respect to a Hazardous Environmental Condition at the Site, if any, and possible changes in the Contract Documents due to any Hazardous Environmental Condition uncovered or revealed at the Site which was not shown or indicated in the Drawings or Specifications or identified in the Contract Documents to be within the scope of the Work appear in paragraph 4.06 of the General Conditions.

4.05 Upon a request directed to the Purchasing Division (purchasing@ircgov.com or (772) 226-1416), OWNER will provide Bidder access to the Site to conduct such examinations, investigations, explorations, tests, and studies as Bidder deems necessary for submission of a Bid. Bidder shall fill all holes and clean up and restore the Site to its former condition upon completion of such explorations, investigations, tests, and studies.

4.06 “This paragraph has been deleted intentionally”

4.07 It is the responsibility of each Bidder before submitting a Bid to:

A. examine and carefully study the Bidding Documents, including any Addenda and the other related data identified in the Bidding Documents;

B. VISIT THE SITE AND BECOME FAMILIAR WITH AND SATISFY BIDDER AS TO THE GENERAL, LOCAL, AND SITE CONDITIONS THAT MAY AFFECT COST, PROGRESS, AND PERFORMANCE OF THE WORK;

C. become familiar with and satisfy Bidder as to all federal, state, and local Laws and Regulations that may affect cost, progress, or performance of the Work;

D. carefully study all reports of explorations and tests of subsurface conditions at or contiguous to the Site and all drawings of physical conditions in or relating to existing surface or subsurface structures at or contiguous to the Site (except Underground Facilities) which have been identified in the Supplementary Conditions as provided in paragraph 4.02 of the General Conditions, and carefully study all reports and drawings of a Hazardous Environmental Condition, if any, at the Site which have been identified in the Supplementary Conditions as provided in paragraph 4.06 of the General Conditions;

E. obtain and carefully study (or assume responsibility for doing so) all additional or supplementary examinations, investigations, explorations, tests, studies, and data concerning conditions (overhead, surface, subsurface, and Underground Facilities) at or contiguous to the Site which may affect cost, progress, or performance of the Work or which relate to any aspect of the means, methods, techniques, sequences, and procedures of construction to be employed by Bidder, including any specific means, methods, techniques, sequences, and procedures of construction expressly required by the Bidding Documents, and safety precautions and programs incident thereto;

F. agree at the time of submitting its Bid that no further examinations, investigations, explorations, tests, studies, or data are necessary for the determination of its Bid for performance of the Work at the price bid and within the times and in accordance with the other terms and conditions of the Bidding Documents;

G. become aware of the general nature of the work to be performed by OWNER and others at the Site that relates to the Work as indicated in the Bidding Documents;

H. correlate the information known to Bidder, information and observations obtained from visits to the Site, reports and drawings identified in the Bidding Documents, and all additional examinations, investigations, explorations, tests, studies, and data with the Bidding Documents;

I. promptly give ENGINEER written notice of all conflicts, errors, ambiguities, or discrepancies that Bidder discovers in the Bidding Documents and confirm that the written resolution thereof by ENGINEER is acceptable to Bidder; and

J. determine that the Bidding Documents are generally sufficient to indicate and convey understanding of all terms and conditions for the performance of the Work.

4.08 The submission of a Bid will constitute an incontrovertible representation by Bidder that Bidder has complied with every requirement of this Article 4, that without exception the Bid is premised upon performing and furnishing the Work required by the Bidding Documents and applying any specific means, methods, techniques, sequences, and procedures of construction that may be shown or indicated or expressly required by the Bidding Documents, that Bidder has given ENGINEER written notice of all conflicts, errors, ambiguities, and discrepancies that Bidder has discovered in the Bidding Documents and the written resolutions thereof by ENGINEER are acceptable to Bidder, and that the Bidding Documents are generally sufficient to indicate and convey understanding of all terms and conditions for performing and furnishing the Work.

ARTICLE 5 - PRE-BID CONFERENCE

5.01 The date, time, and location for the NON-MANDATORY Pre-Bid conference, if any, is specified in the Advertisement for Bids. Representatives of OWNER and ENGINEER will be present to discuss the Project. Bidders are not required, but are highly encouraged, to attend and participate in the conference. ENGINEER will transmit to all prospective Bidders of record such Addenda as ENGINEER considers necessary in response to questions arising at the conference. Oral statements may not be relied upon and will not be binding or legally effective.

ARTICLE 6 - SITE AND OTHER AREAS

6.01 The Site is identified in the Bidding Documents. All additional lands and access thereto required for temporary construction facilities, construction equipment, or storage of materials and equipment to be incorporated in the Work are to be obtained and paid for by CONTRACTOR. Easements for permanent structures or permanent changes in existing facilities are to be obtained and paid for by OWNER unless otherwise provided in the Bidding Documents.

ARTICLE 7 - INTERPRETATIONS AND ADDENDA

7.01 CONE OF SILENCE. Potential bidders and their agents shall not communicate in any way with the Board of County Commissioners, County Administrator or any County staff other than Purchasing personnel in reference or relation to this solicitation. This restriction shall be effective from the time of bid advertisement until the Board of County Commissioners meets to authorize award. Such communication may result in disqualification.

7.02 All questions about the meaning or intent of the Bidding Documents are to be submitted to PURCHASING (purchasing@ircgov.com) in writing. Interpretations or clarifications considered necessary by ENGINEER in response to such questions will be issued by Addenda mailed or delivered to all parties through the Issuing Office as having received the Bidding Documents. Questions received less than ten days prior to the date for opening of Bids may not be answered. Only questions answered by Addenda will be binding. Oral and other interpretations or clarifications will be without legal effect.

7.03 Addenda may be issued to clarify, correct, or change the Bidding Documents as deemed advisable by OWNER or ENGINEER.

ARTICLE 8 - BID SECURITY

8.01 Any Each Bid must be accompanied by Bid Security made payable to OWNER in the amount of five percent of the Bidder's maximum base bid price and in the form of a certified check; cashier's check; or an AIA Document A310 Bid Bond issued by a surety meeting the requirements of Paragraph 5.01 of the General Conditions. The Bid Bond shall be executed by such sureties as are named in the current list of "Companies Holding Certificates of Authority as Acceptable Sureties on Federal Bonds and as Acceptable Reinsuring Companies" as published in Circular 570 (amended) by the Financial Management Service, Surety Bond Branch, U.S. Department of the Treasury. The Surety must be authorized to issue surety bonds in Florida. The Bidder shall require the attorney-in-fact who executes any Bond, to affix to each a current certified copy of their Power of Attorney, reflecting such person's authority as Power of Attorney in the State of Florida. Further, at the time of execution of the Contract, the Successful Bidder shall for all Bonds, provide a copy of the Surety's current valid Certificate of Authority issued by the United States Department of the Treasury under 31 United States Code sections 9304-9308. The Surety shall also meet the requirements of paragraphs 5.01 and 5.02 of the General Conditions.

8.02 The Bid security of the Successful Bidder will be retained until such Bidder has executed the Contract Documents, furnished the required contract security and met the other conditions of the Notice of Award, whereupon the Bid security will be returned. If the Successful Bidder fails to execute and deliver the Contract Documents and furnish the required contract security within 15 days after the Notice of Award, OWNER may annul the Notice of Award and the Bid security of that Bidder will be retained by the owner. The Bid Security of other Bidders whom OWNER believes to have a reasonable chance of receiving the award may be retained by OWNER until the earlier of seven days after the Effective Date of the Agreement or 91 days after the Bid opening, whereupon Bid Security furnished by such Bidders will be returned.

8.03 Bid Security of other Bidders whom OWNER believes do not have a reasonable chance of receiving the award will be returned within seven days after the Bid opening.

ARTICLE 9 - CONTRACT TIMES

9.01 The number of calendar days within which, or the dates by which, the Work is to be (a) Substantially Completed and (b) also completed and ready for final payment are set forth in the Agreement.

ARTICLE 10 - LIQUIDATED DAMAGES

10.01 Provisions for liquidated damages, if any, are set forth in the Agreement.

ARTICLE 11 - SUBSTITUTE AND "OR-EQUAL" ITEMS

11.01 The Contract, if awarded, will be on the basis of materials and equipment specified or described in the Bidding Documents without consideration of possible substitute or "or-equal" items. Whenever it is specified or described in the Bidding Documents that a substitute or "or-equal" item of material or equipment may be furnished or used by CONTRACTOR if acceptable to ENGINEER, application for such acceptance will not be considered by ENGINEER until after the Effective Date of the Agreement. The procedure for submission of any such application by CONTRACTOR and consideration by ENGINEER is set forth in the General Conditions and may be supplemented in the General Requirements.

ARTICLE 12 - SUBCONTRACTORS, SUPPLIERS, AND OTHERS

12.01 If the Supplementary Conditions require the identity of certain Subcontractors, Suppliers, individuals, or entities to be submitted to OWNER in advance of a specified date prior to the Effective Date of the Agreement, the apparent Successful Bidder, and any other Bidder so requested, shall within five days after Bid opening, submit to OWNER a list of all such Subcontractors, Suppliers, individuals, or entities proposed for those portions of the Work for which such identification is required. Such list shall be accompanied by an experience statement with pertinent information regarding similar projects and other evidence of qualification for each such Subcontractor, Supplier, individual, or entity if requested by OWNER. If OWNER or ENGINEER, after due investigation, has reasonable objection to any proposed Subcontractor, Supplier, individual, or entity, OWNER may, before the Notice of Award is given, request apparent Successful Bidder to submit a substitute, without an increase in the Bid.

12.02 If apparent Successful Bidder declines to make any such substitution, OWNER may award the Contract to the next lowest Bidder that proposes to use acceptable Subcontractors, Suppliers, individuals, or entities. Declining to make requested substitutions will not constitute grounds for forfeiture of the Bid security of any Bidder. Any Subcontractor, Supplier, individual, or entity so listed and against which OWNER or ENGINEER makes no written objection prior to the giving of the Notice of Award will be deemed acceptable to OWNER and ENGINEER subject to revocation of such acceptance after the Effective Date of the Agreement as provided in paragraph 6.06 of the General Conditions.

12.03 CONTRACTOR shall not be required to employ any Subcontractor, Supplier, individual, or entity against whom CONTRACTOR has reasonable objection.

ARTICLE 13 - PREPARATION OF BID

13.01 The Bid form is included with the Bidding Documents. Only the bid form provided by OWNER is acceptable (Bidders are not to recreate the bid form). **Bids not submitted on the bid form(s) shall be rejected, as will bids submitted on rewritten or recreated bid forms.**

13.02 All blanks on the Bid form shall be completed by printing in ink or by typewriter and the Bid signed. A Bid price shall be indicated for each section, Bid item, alternative, adjustment unit price item, and unit price item listed therein, or the words "No Bid," "No Change," or "Not Applicable" entered.

13.03 A Bid by a corporation shall be executed in the corporate name by the president or a vice-president or other corporate officer accompanied by evidence of authority to sign. The corporate seal shall be affixed and attested by the secretary or an assistant secretary. The corporate address and state of incorporation shall be shown below the signature.

13.04 A Bid by a partnership shall be executed in the partnership name and signed by a partner (whose title must appear under the signature), accompanied by evidence of authority to sign. The official address of the partnership shall be shown below the signature.

13.05 A Bid by a limited liability company shall be executed in the name of the firm by a member and accompanied by evidence of authority to sign. The state of formation of the firm and the official address of the firm must be shown below the signature.

13.06 A Bid by an individual shall show the Bidder's name and official address.

13.07 A Bid by a joint venture shall be executed by each joint venturor in the manner indicated on the Bid form. The official address of the joint venture must be shown below the signature.

13.08 All names shall be typed or printed in ink below the signatures.

13.09 The Bid shall contain an acknowledgment of receipt of all Addenda, the numbers of which shall be filled in on the Bid form.

13.10 The address and telephone number for communications regarding the Bid shall be shown.

13.11 The Bid shall contain evidence of Bidder's authority and qualification to do business in the state where the Project is located or covenant to obtain such qualification prior to award of the Contract. Bidder's state contractor license number or county registration number for the state or county of the Project, if any, shall also be shown on the Bid form.

13.12 All supporting information requested in the Bid Form must be furnished. Do not leave any questions or requests unanswered.

13.13 In accordance with Florida Statutes Section 218.80, the "Public Bid Disclosure Act", Indian River County as OWNER is obligated to disclose all license, permit, impact, or inspection fees that are payable to Indian River County in connection with the construction of the Work by the accepted bidder. All permit, impact, or inspection fees payable to Indian River County in connection with the work on this County project will be paid by Indian River County, with the exception of re-inspection fees. The Bidder shall not include ANY PERMIT, IMPACT, NOR INSPECTION FEES payable to **Indian River County** in the bid. A copy of the IRC Building

Department Fee Schedule has been included in Appendix 5.

13.14 CONTRACTOR shall furnish all labor, materials, equipment and incidentals necessary to perform additional work not covered on the Contract Drawings. The **FORCE ACCOUNT** is intended as a contingency for unforeseen work. Lump sum amount for **FORCE ACCOUNT** work is included in the bid schedule. The value of force account work will be determined in accordance with Article 12 of the General Conditions.

ARTICLE 14 - BASIS OF BID; EVALUATION OF BIDS

14.01 Unit Price

A. Bidders shall submit a Bid on a unit price basis for each item of Work listed in the Bid schedule. Omission of one or more unit prices shall disqualify the bid.

B. The total of all estimated prices will be determined as the sum of the products of the estimated quantity of each item and the unit price Bid for the item. The final quantities and Contract Price will be determined in accordance with paragraph 11.03 of the General Conditions.

C. Discrepancies between the multiplication of units of Work and unit prices will be resolved in favor of the unit prices. Discrepancies between the indicated sum of any column of figures and the correct sum thereof will be resolved in favor of the correct sum. Discrepancies between words and figures will be resolved in favor of the words.

14.02 The Bid price shall include such amounts as the Bidder deems proper for overhead and profit on account of cash allowances, if any, named in the Contract Documents as provided in paragraph 11.02 of the General Conditions.

14.03 The Bidder's attention is called to the fact that any estimate of quantities of work to be done and materials to be furnished under the Specifications as shown on the Bid Schedule, or elsewhere, is approximate only and not guaranteed. The OWNER does not assume any responsibility that the final quantities shall remain in strict accordance with the estimated quantities, nor shall the Bidder plead misunderstanding or deception because of such estimate of quantities or of the character, location of the work, or other conditions pertaining thereto.

ARTICLE 15 - SUBMITTAL OF BID

15.01 The Bid form is to be completed and submitted with the Bid security and the following data:

- A. Sworn Statement under Section 105.08, Indian River County Code, on Disclosure of Relationships.
- B. Qualifications Questionnaire.
- C. List of Subcontractors.
- D. Certification Regarding Prohibition Against Contracting with Scrutinized Companies

15.02 A Bid shall be submitted no later than the date and time prescribed and at the place indicated in the advertisement or invitation to Bid and shall be enclosed in an opaque sealed envelope plainly

marked with the Project Title and Bid Number (and, if applicable, the designated portion of the Project for which the Bid is submitted), Bid Number, the name and address of Bidder, and shall be accompanied by the Bid security and other required documents. If mail or other delivery system sends a Bid, the sealed envelope containing the Bid shall be enclosed in a separate envelope plainly marked on the outside with the notation "BID ENCLOSED." A mailed Bid shall be addressed to Indian River County, Purchasing Division, 1800 27th Street, Vero Beach, Florida, 32960.

ARTICLE 16 - MODIFICATION AND WITHDRAWAL OF BID

16.01 A Bid may be modified or withdrawn by an appropriate document duly executed in the manner that a Bid must be executed and delivered to the place where Bids are to be submitted prior to the date and time for the opening of Bids.

16.02 If within 24 hours after Bids are opened any Bidder files a duly signed written notice with OWNER and promptly thereafter demonstrates to the reasonable satisfaction of OWNER that there was a material and substantial mistake in the preparation of its Bid, that Bidder may withdraw its Bid, and the Bid security will be returned. Thereafter, if the Work is rebid, that Bidder will be disqualified from further bidding on the Work.

ARTICLE 17 - OPENING OF BIDS

17.01 Bids will be opened at the time and place indicated in the advertisement or invitation to Bid and, unless obviously non-responsive, read aloud publicly. An abstract of the amounts of the base Bids and major alternates, if any, will be made available to Bidders after the opening of Bids.

ARTICLE 18 - BIDS TO REMAIN SUBJECT TO ACCEPTANCE

18.01 All Bids will remain subject to acceptance for the period of time stated in the Bid Form, but OWNER may, in its sole discretion, release any Bid and return the Bid security prior to the end of this period.

ARTICLE 19 - AWARD OF CONTRACT

19.01 OWNER reserves the right to reject any or all Bids, including without limitation, nonconforming, nonresponsive, unbalanced, or conditional Bids. OWNER further reserves the right to reject the Bid of any Bidder whom it finds, after reasonable inquiry and evaluation, to be non-responsible. OWNER may also reject the Bid of any Bidder if OWNER believes that it would not be in the best interest of the Project to make an award to that Bidder. OWNER also reserves the right to waive all technicalities and informalities not involving price, time, or changes in the work and to negotiate contract terms with the Successful Bidder. The County will not reimburse any Bidder for bid preparation costs. Owner reserves the right to cancel the award of any Contract at any time before the execution of such Contract by all parties without any liability to the Owner. For and in consideration of the Owner considering Bids submitted, the Bidder, by submitting its Bid, expressly waives any claim to damages, of any kind whatsoever, in the event the Owner exercises its right to cancel the award in accordance herewith.

19.02 More than one Bid for the same Work from an individual or entity under the same or different names will not be considered. Reasonable grounds for believing that any Bidder has an interest in more than one Bid for the Work may be cause for disqualification of that Bidder and the rejection of all Bids in which that Bidder has an interest.

19.03 In evaluating Bids, OWNER will consider whether or not the Bids comply with the prescribed requirements, and such alternates, unit prices and other data, as may be requested in the Bid Form or prior to the Notice of Award.

19.04 In evaluating Bidders, OWNER will consider the qualifications of Bidders and may consider the qualifications and experience of Subcontractors, Suppliers, and other individuals or entities proposed for those portions of the Work for which the identity of Subcontractors, Suppliers, and other individuals or entities must be submitted as provided in the Supplementary Conditions.

19.05 OWNER may conduct such investigations as OWNER deems necessary to establish the responsibility, qualifications, and financial ability of Bidders, proposed Subcontractors, Suppliers, individuals, or entities to perform the Work in accordance with the Contract Documents.

19.06 If the Contract is to be awarded, OWNER will award the Contract to the Bidder whose Bid is in the best interests of the Project.

19.07 OWNER has no local ordinance or preferences, as set forth in FS 255.0991 (2) in place, therefore no preference prohibited by that section will be considered in the acceptance, review or award of this bid.

19.08 Any actual or prospective bidder or proposer who is aggrieved in connection with the bidding and/or selection process may protest to the OWNER's Purchasing Manager. The protest shall be submitted in writing to the Purchasing Manager within seven (7) calendar days after the bidder or proposer knows or should have known of the facts giving rise to the protest.

19.09 CONTRACTOR certifies that it and its related entities as defined by Florida law are not on the Scrutinized Companies that Boycott Israel List, created pursuant to s. 215.4725 of the Florida Statutes, and are not engaged in a boycott of Israel. In addition, if this agreement is for goods or services of one million dollars or more, CONTRACTOR certifies that it and its related entities as defined above by Florida law are not on the Scrutinized Companies with Activities in Sudan List or the Scrutinized Companies with Activities in the Iran Petroleum Energy Sector List, created pursuant to Section 215.473 of the Florida Statutes and are not engaged in business operations in Cuba or Syria.

OWNER may terminate this Contract if CONTRACTOR is found to have submitted a false certification as provided under section 287.135(5), Florida Statutes, been placed on the Scrutinized Companies with Activities in Sudan List or the Scrutinized Companies with Activities in the Iran Petroleum Energy Sector List, or been engaged in business operations in Cuba or Syria, as defined by section 287.135, Florida Statutes.

OWNER may terminate this Contract if CONTRACTOR, including all wholly owned subsidiaries, majority-owned subsidiaries, and parent companies, that exist for the purpose of making profit, is found to have been placed on the Scrutinized Companies that Boycott Israel List or is engaged in a boycott of Israel as set forth in section 215.4725, Florida Statutes.

Accordingly, firms responding to this solicitation shall return with their response an executed copy of the attached "Certification Regarding Prohibition Against Contracting With Scrutinized Companies." Failure to return this executed form with submitted bid/proposal/statement of

qualifications will result in the response being deemed non-responsive and eliminated from consideration.

ARTICLE 20 - CONTRACT SECURITY AND INSURANCE

20.01 Article 5 of the General Conditions, as may be modified by the Supplementary Conditions, sets forth OWNER's requirements as to Public Construction Bond and insurance. When the Successful Bidder delivers the executed Agreement to OWNER, it must be accompanied by the required insurance certificate(s) and Bond, unless the Bond has been waived due to the total contract being less than \$100,000.

ARTICLE 21 - SIGNING OF AGREEMENT

21.01 When OWNER gives a Notice of Award to the Successful Bidder, it shall be accompanied by the required number of unsigned counterparts of the Agreement with the other Contract Documents which are identified in the Agreement as attached thereto. Within fifteen (15) days thereafter, Successful Bidder shall sign and deliver the required number of counterparts of the Agreement and attached documents to OWNER.

21.02 OWNER shall return one fully signed counterpart to Successful Bidder.

21.03 Should Bidder to whom the Contract has been awarded refuse or fail to complete the requirements of Article 21.01 above, the additional time in calendar days, required to correctly complete the documents will be deducted, in equal amount, from the Contract time. Or, the OWNER may elect to revoke the Award and the OWNER shall hold the Bid Bond for consequential damages incurred, and the Contract may be awarded as the OWNER desires.

**** END OF SECTION ****

SECTION 00300 – Bid Package Contents

THIS PACKAGE CONTAINS:

<u>SECTION TITLE</u>	<u>SECTION NUMBER</u>
Bid Form	00310
Bid Bond	00430
Sworn Statement on Disclosure of Relationships	00452
Qualifications Questionnaire	00456
List of Subcontractors	00458
Certification Regarding Prohibition Against Contracting with Scrutinized Companies	00460

SUBMIT ONE (1) ORIGINAL AND ONE (1) COPY OF THIS COMPLETE PACKAGE WITH YOUR BID

*** * END OF SECTION * ***

SECTION 00310 – Bid Form

PROJECT IDENTIFICATION:

Project Name: **Hallstrom Farmstead Pavilions**

Bid Number: **2022002**

Project Address: **1723 Old Dixie Highway**
Vero Beach, FL 32962

Project Description: ***The project includes the construction of two picnic pavilions at the Hallstrom Farmstead Conservation Area.***

THIS BID IS SUBMITTED TO: INDIAN RIVER COUNTY
1800 27th Street
VERO BEACH, FLORIDA 32960

1.01 The undersigned Bidder proposes and agrees, if this Bid is accepted, to enter into an Agreement with OWNER in the form included in the Bidding Documents to perform all Work as specified or indicated in the Bidding Documents for the prices and within the times indicated in this Bid and in accordance with the other terms and conditions of the Bidding Documents.

2.01 Bidder accepts all of the terms and conditions of the Advertisement or Invitation to Bid and Instructions to Bidders, including without limitation those dealing with the disposition of Bid security. The Bid will remain subject to acceptance for 90 days after the Bid opening, or for such longer period of time that Bidder may agree to in writing upon request of OWNER.

3.01 In submitting this Bid, Bidder represents, as set forth in the Agreement, that:

A. Bidder has examined and carefully studied the Bidding Documents, the other related data identified in the Bidding Documents, and the following Addenda, receipt of all which is hereby acknowledged.

<u>Addendum Date</u>	<u>Addendum Number</u>
_____	_____
_____	_____
_____	_____

B. Bidder has visited the Site and become familiar with and is satisfied as to the general, local and Site conditions that may affect cost, progress, and performance of the Work.

C. Bidder is familiar with and is satisfied as to all federal, state and local Laws and Regulations that may affect cost, progress and performance of the Work.

D. Bidder has carefully studied all: (1) reports of explorations and tests of subsurface conditions at or contiguous to the Site and all drawings of physical conditions in or relating to existing surface or subsurface structures at or contiguous to the Site (except Underground Facilities) which have been identified in the Supplementary Conditions as provided in paragraph 4.02 of the General Conditions, and (2) reports and drawings of a Hazardous Environmental Condition, if any, which have been identified in the Supplementary Conditions as provided in paragraph 4.06 of the General Conditions.

E. Bidder has obtained and carefully studied (or assumes responsibility for having done so) all additional or supplementary examinations, investigations, explorations, tests, studies and data concerning conditions (surface, subsurface and Underground Facilities) at or contiguous to the Site which may affect cost, progress, or performance of the Work or which relate to any aspect of the means, methods, techniques, sequences, and procedures of construction to be employed by Bidder, including applying the specific means, methods, techniques, sequences, and procedures of construction expressly required by the Bidding Documents to be employed by Bidder, and safety precautions and programs incident thereto.

F. Bidder does not consider that any further examinations, investigations, explorations, tests, studies, or data are necessary for the determination of this Bid for performance of the Work at the price(s) bid and within the times and in accordance with the other terms and conditions of the Bidding Documents.

G. Bidder is aware of the general nature of work to be performed by OWNER and others at the Site that relates to the Work as indicated in the Bidding Documents.

H. Bidder has correlated the information known to Bidder, information and observations obtained from visits to the Site, reports and drawings identified in the Bidding Documents, and all additional examinations, investigations, explorations, tests, studies, and data with the Bidding Documents.

I. Bidder has given ENGINEER written notice of all conflicts, errors, ambiguities, or discrepancies that Bidder has discovered in the Bidding Documents, and the written resolution thereof by ENGINEER is acceptable to Bidder.

J. The Bidding Documents are generally sufficient to indicate and convey understanding of all terms and conditions for the performance of the Work for which this Bid is submitted.

4.01 Bidder further represents that this Bid is genuine and not made in the interest of or on behalf of any undisclosed individual or entity and is not submitted in conformity with any agreement or rules of any group, association, organization or corporation; Bidder has not directly or indirectly induced or solicited any other Bidder to submit a false or sham Bid; Bidder has not solicited or induced any individual or entity to refrain from bidding; and Bidder has not sought by collusion to obtain for itself any advantage over any other Bidder or over OWNER.

[The remainder of page intentionally left blank]

ITEMIZED BID SCHEDULE
PROJECT NAME: Hallstrom Farmstead Pavilions
BID NO. 2022002

BIDDER'S NAME: _____

Item No.	Description	Unit	Unit Price	Quantity	Amount
101-1	MOBILIZATION/DEMOBILIZATION	LS	\$	1	\$
101-2	MAINTENANCE OF TRAFFIC	LS	\$	1	\$
104-2	PREVENTION, CONTROL & ABATEMENT OF EROSION & WATER POLLUTION	LS	\$	1	\$
110-1-1	CLEARING AND GRUBBING	LS	\$	1	\$
N/A	GRADING	LS	\$	1	\$
570-1-2	PERFORMANCE TURF (SOD) BAHIA	SY	\$	720	\$
999-1	CONSTRUCTION LAYOUT/RECORD DRAWINGS	LS	\$	1	\$
N/A	30' BY 30' PAVILION WITH CONCRETE FLOOR	LS	\$	1	\$
N/A	24' BY 24' PAVILION WITH STABILIZED SEMI-PERVIOUS FLOOR	LS	\$	1	\$
N/A	PERMITS (TO BE PAID BY IRC)	LS	\$	1	\$
N/A	PUBLIC CONSTRUCTION BOND	LS	\$	1	\$
999-25	FORCE ACCOUNT				\$10,000.00
TOTAL BID AMOUNT (INCLUDING FORCE ACCOUNT)				\$	

TOTAL PROJECT BID AMOUNT IN WORDS _____

Add/Alternate Bid

N/A	Increase/Decrease in cost for 30' BY 30' PAVILION WITH STABILIZED SEMI-PERVIOUS FLOOR (OPTION B) Indicate + (increase) or - (decrease) to total cost	\$
-----	---	----

LS=Lump Sum EA=Each PI=Per Intersection AS=Assembly SF= Square Foot SY=Square Yard
 GAL=Gallon LF=Linear Foot CY=Cubic Yard TN=TON

NOTE: IF THERE IS A DISCREPANCY BETWEEN THE PLANS (SUMMARY OF PAY ITEMS) AND THE ITEMIZED BID SCHEDULE, THE BID SCHEDULE WILL BE UTILIZED FOR BIDDING PURPOSES.

5.01 Bidder shall complete the Work in accordance with the Contract Documents for the price(s) contained in the Bid Schedule:

- A. The Discrepancies between the multiplication of units of Work and unit prices will be resolved in favor of the unit prices. Discrepancies between the indicated sum of any column of figures and the correct sum thereof will be resolved in favor of the correct sum. Discrepancies between words and figures will be resolved in favor of the words.
- B. The Owner reserves the right to omit or add to the construction of any portion or portions of the work heretofore enumerated or shown on the plans. Furthermore, the Owner reserves the right to omit in its entirety any one or more items of the Contract without forfeiture of Contract or claims for loss of anticipated profits or any claims by the Contractor on account of such omissions.
- C. Bidder acknowledges that estimated quantities are not guaranteed, and are solely for the purpose of comparison of Bids, and final payment for all Unit Price Bid items will be based on actual quantities provided. The quantities actually required to complete the contract and work may be less or more than so estimated, and, if so, no action for damages or for loss of profits shall accrue to the Contractor by reason thereof.
- D. Unit Prices have been computed in accordance with paragraph 11.03.B of the General Conditions.

6.01 Bidder agrees that the Work will be substantially completed and ready for final payment in accordance with paragraph 14.07.B of the General Conditions on or before the dates or within the number of calendar days indicated in the Agreement.

6.02 Bidder accepts the provisions of the Agreement as to liquidated damages in the event of failure to complete the Work within the times specified, which shall be stated in the Agreement.

7.01 The following documents are attached to and made a condition of this Bid:

- A. Itemized Bid Schedule;
- B. Required Bid security in the form of _____;
- C. Sworn Statement under Section 105.08, Indian River Code, on Disclosure of Relationships;
- D. Qualifications Questionnaire;
- E. List of Subcontractors;
- F. Certification Regarding Prohibition Against Contracting with Scrutinized Companies

8.01 The terms used in this Bid with initial capital letters have the meanings indicated in the Instructions to Bidders, the General Conditions, and the Supplementary Conditions.

SUBMITTED on _____, 20__.

State Contractor License No. _____

If Bidder is:

An Individual

Name (typed or printed): _____

By: _____ (SEAL)
(Individual's signature)

Doing business as: _____

Business address: _____

Phone No.: _____ FAX No.: _____

Email: _____

A Partnership

Partnership Name: _____ (SEAL)

By: _____
(Signature of general partner -- attach evidence of authority to sign)

Name (typed or printed): _____

Business address: _____

Phone No.: _____ FAX No.: _____

Email: _____

A Corporation

Corporation Name: _____ (SEAL)

State of Incorporation: _____

Type (General Business, Professional, Service, Limited Liability): _____

By: _____
(Signature -- attach evidence of authority to sign)

Name (typed or printed): _____

Title: _____

(CORPORATE SEAL)

Attest _____
(Signature of Corporate Secretary)

Business address: _____

Phone No.: _____ FAX No.: _____

Email: _____

Date of Qualification to do business is _____.

A Joint Venture

Joint Venture Name: _____ (SEAL)

By: _____
(Signature of joint venture partner -- attach evidence of authority to sign)

Name (typed or printed): _____

Title: _____

Business address: _____

Phone No.: _____ FAX No.: _____

Email: _____

Joint Venture Name: _____ (SEAL)

By: _____
(Signature -- attach evidence of authority to sign)

Name (typed or printed): _____

Title: _____

Business address: _____

Phone No.: _____ FAX No.: _____

Email: _____

Phone and FAX Number, and Address for receipt of official communications:

(Each joint venturor must sign. The manner of signing for each individual, partnership, and corporation that is a party to the joint venture should be in the manner indicated above.)

**** END OF SECTION ****

SECTION 00430 – Bid Bond

AIA DOCUMENT A310 BID BOND

The Contractor shall use the document form entitled “AIA Document A310 Bid Bond.”

END OF SECTION

SECTION 00452 – Sworn Statement on Disclosure of Relationships

**SWORN STATEMENT UNDER SECTION 105.08, INDIAN RIVER COUNTY CODE,
ON DISCLOSURE OF RELATIONSHIPS**

THIS FORM MUST BE SIGNED IN THE PRESENCE OF A NOTARY PUBLIC OR OTHER OFFICER AUTHORIZED TO ADMINISTER OATHS.

1. This sworn statement MUST be submitted with Bid, Proposal or Contract No. 2022022

For Hallstrom Farmstead Pavilions

2. This sworn statement is submitted by: _____

(Name of entity submitting Statement)

whose business address is:

3. My name is _____

(Please print name of individual signing)

and my relationship to the entity named above is _____

4. I understand that an “affiliate” as defined in Section 105.08, Indian River County Code, means:

The term “affiliate” includes those officers, directors, executives, partners, shareholders, employees, members, and agents who are active in the management of the entity.

5. I understand that the relationship with a County Commissioner or County employee that must be disclosed as follows:

Father, mother, son, daughter, brother, sister, uncle, aunt, first cousin, nephew, niece, husband, wife, father-in-law, mother-in-law, daughter-in-law, son-in-law, brother-in-law, sister-in-law, stepfather, stepmother, stepson, stepdaughter, stepbrother, stepsister, half brother, half sister, grandparent, or grandchild.

6. Based on information and belief, the statement, which I have marked below, is true in relation to the entity submitting this sworn statement. [Please indicate which statement applies.]

_____ Neither the entity submitting this sworn statement, nor any officers, directors, executives, partners, shareholders, employees, members, or agents who are active in management of the entity, have any relationships as defined in section 105.08, Indian River County Code, with any County Commissioner or County employee.

_____ The entity submitting this sworn statement, or one or more of the officers, directors, executives, partners, shareholders, employees, members, or agents, who are active in management of the entity have the following relationships with a County Commissioner or County employee:

Name of Affiliate or entity	Name of County Commissioner or employee	Relationship
_____	_____	_____
_____	_____	_____
_____	_____	_____

(Signature)

(Date)

STATE OF _____

COUNTY OF _____

Sworn to (or affirmed) and subscribed before me by means of physical presence or online notarization, this _____ day of _____ 20____, by _____
(name of person making statement).

(Signature of Notary Public - State of Florida)
(Print, Type, or Stamp Commissioned Name of Notary Public)

who is personally known to me or who has produced _____ as identification.

SECTION 00456 – QUALIFICATIONS QUESTIONNAIRE

NOTICE: THE OWNER RETAINS THE DISCRETION TO REJECT THE BIDS OF NON-RESPONSIBLE BIDDERS.

Documentation Submitted with Bid No: 2022002

Project Name: Hallstrom Farmstead Pavilions

1. Bidder's Name / Address: _____

2. Bidder's Telephone & FAX Numbers: _____

3. Licensing and Corporate Status:
 - a. Is Contractor License current? _____
 - b. Bidder's Contractor License No: _____
[Attach a copy of Contractor's License to the bid]
 - c. Attach documentation from the State of Florida Division of Corporations that indicates the business entity's status is active and that lists the names and titles of all officers.
4. Number of years the firm has performed business as a Contractor in construction work of the type involved in this contract: _____
5. What is the last project OF THIS NATURE that the firm has completed?

6. Has the firm ever failed to complete work awarded to you? _____

[If your answer is "yes", then attach a separate page to this questionnaire that explains the circumstances and list the project name, Owner, and the Owner's telephone number for each project in which the firm failed to complete the work.]
7. Has the firm ever been assessed liquidated damages? _____

[If your answer is "yes", then attach a separate page to this questionnaire that explains the circumstances and list the project name, Owner, and the Owner's telephone number for each project in which liquidated damages have been assessed.]
8. Has the firm ever been charged by OSHA for violating any OSHA regulations? _____

[If your answer is "yes", then attach a separate page to this questionnaire that explains the circumstances and list the project name, Owner, and the Owner's telephone number for each project in which OSHA violations were alleged.]
9. Has the firm implemented a drug-free workplace program in compliance with Florida Statute 287.087? _____

(In the case of a tie, preference will be given to businesses with drug-free workplace programs)

10. Has the firm ever been charged with noncompliance of any public policy or rules?

[If your answer is "yes", then attach a separate page to this questionnaire that explains the circumstances and list the project name, Owner, and the Owner's telephone number for each project.]

11. Attach to this questionnaire, a notarized financial statement and other information that documents the firm's financial strength and history.

12. Has the firm ever defaulted on any of its projects? _____

[If your answer is "yes", then attach a separate page to this questionnaire that explains the circumstances and list the project name, Owner, and the Owner's telephone number for each project in which a default occurred.]

13. Attach a separate page to this questionnaire that summarizes the firm's current workload and that demonstrates its ability to meet the project schedule.

14. Name of person who inspected the site of the proposed work for the firm:

Name: _____ Date of Inspections: _____

15. Name of on-site Project Foreman: _____

Number of years of experience with similar projects as a Project Foreman: _____

16. Name of Project Manager: _____

Number of years of experience with similar projects as a Project Manager: _____

17. State your total bonding capacity: _____

18. State your bonding capacity per job: _____

19. Please provide name, address, telephone number, and contact person of your bonding company:

[The remainder of this page was left blank intentionally]

19. Complete the following table for SIMILAR projects:

Name of Project	Date Completed	Owner	Contact Person: Name/ Email Address/Phone	Original Contract Amount	Final Contract Amount

SECTION 00458 – List of Subcontractors

The Bidder **MUST** list below the name and address of each Subcontractor who will perform work under this Contract in excess of one-half percent of the total bid price, and shall also list the portion of the work which will be done by such Subcontractor. After the opening of Bids, additions, changes or substitutions will not be allowed unless approved by Indian River County after a request for such a change has been submitted in writing by the Contractor, which shall include reasons for such request. Subcontractors must be properly licensed and hold a valid Certificate of Competency.

Documentation Submitted with Bid No. 2022002 for Hallstrom Farmstead Pavilions

	<u>Work to be Performed</u>	<u>Subcontractor's Name/Address</u>	<u>Portion of Work (%)</u>
1.			
2.			
3.			
4.			
5.			
6.			
7.			
8.			
9.			
10.			
11.			
12.			
13.			
14.			

Note: Attach additional sheets if required.

**** END OF SECTION ****

SECTION 00460 – CERTIFICATION REGARDING PROHIBITION AGAINST CONTRACTING WITH SCRUTINIZED COMPANIES

I hereby certify that neither the undersigned entity, nor any of its wholly owned subsidiaries, majority-owned subsidiaries, parent companies, or affiliates of such entities or business associations, that exists for the purpose of making profit have been placed on the Scrutinized Companies that Boycott Israel List created pursuant to s. 215.4725 of the Florida Statutes, or are engaged in a boycott of Israel.

In addition, if this solicitation is for a contract for goods or services of one million dollars or more, I hereby certify that neither the undersigned entity, nor any of its wholly owned subsidiaries, majority-owned subsidiaries, parent companies, or affiliates of such entities or business associations, that exists for the purpose of making profit are on the Scrutinized Companies with Activities in Sudan List or the Scrutinized Companies with Activities in the Iran Petroleum Energy Sector List, created pursuant to s. 215.473 of the Florida Statutes, or are engaged in business operations in Cuba or Syria as defined in said statute.

I understand and agree that the County may immediately terminate any contract resulting from this solicitation upon written notice if the undersigned entity (or any of those related entities of respondent as defined above by Florida law) are found to have submitted a false certification or any of the following occur with respect to the company or a related entity: (i) it has been placed on the Scrutinized Companies that Boycott Israel List, or is engaged in a boycott of Israel, or (ii) for any contract for goods or services of one million dollars or more, it has been placed on the Scrutinized Companies with Activities in Sudan List or the Scrutinized Companies with Activities in the Iran Petroleum Energy Sector List, or it is found to have been engaged in business operations in Cuba or Syria.

Name of Respondent: _____

By: _____
(Authorized Signature)

Title: _____

Date: _____

BOARD OF COUNTY COMMISSIONERS



Month xx, 2021

via Email

Company

Attn:

Address

Address

Email address

NOTICE OF AWARD

Reference: *Indian River County Bid No. 2022022*

Project Name: *Hallstrom Farmstead Pavilions*

Dear Mr./Ms. :

It is my pleasure to inform you that on [DATE] the Board of County Commissioners awarded the above-referenced project to your company. The following documents are required before the applicable County department can issue a "Notice to Proceed" letter.

1. Public Construction Bond (unrecorded) in the amount of **100%** of the award amount (**\$.....**).
2. Two Signed Copies of Enclosed Agreement.
3. Certificate of Insurance indicating coverage required by Article 5 of the General Conditions (section 00700 of the bid documents) and Supplemental Conditions (Section 00800 of the bid documents). Certificate(s) **must name Indian River County as additional insured** and must provide for a 30-day Notice of Cancellation.
4. W-9.

The Public Construction Bond must be executed in accordance with section 255.05(1)(a), Florida Statutes. Please submit the Bond, W-9, the Certificate(s) of Insurance and two fully-executed copies of the enclosed agreement to this office at the address provided below no later than [Due **DATE (15 days from award)**]. Failure to comply with the established deadline for submittal of required documents may be grounds for cancellation of award.

Thank you for your prompt attention and if you have any questions, please do not hesitate to contact our office.

Sincerely,

Jennifer Hyde
Purchasing Manager

cc: Parks and Recreation Department

Office of Management and Budget • Purchasing Division
1800 27th Street, Vero Beach, Florida 32960 • (772) 226-1416 • Fax: (772) 770-5140
E-mail: purchasing@ircgov.com

SECTION 00520 - Agreement (Public Works)

TABLE OF CONTENTS

<u>Title</u>	<u>Page</u>
ARTICLE 1 - WORK.....	2
ARTICLE 2 - THE PROJECT	2
ARTICLE 3 - ENGINEER	2
ARTICLE 4 - CONTRACT TIMES.....	2
ARTICLE 5 - CONTRACT PRICE.....	3
ARTICLE 6 - PAYMENT PROCEDURES	3
ARTICLE 7 - INDEMNIFICATION.....	4
ARTICLE 8 - CONTRACTOR'S REPRESENTATIONS	4
ARTICLE 9 - CONTRACT DOCUMENTS.....	5
ARTICLE 10 - MISCELLANEOUS.....	6

[THE REMAINDER OF THIS PAGE WAS LEFT BLANK INTENTIONALLY]

SECTION 00520 - Agreement (Public Works)

THIS AGREEMENT is by and between INDIAN RIVER COUNTY, a Political Subdivision of the State of Florida organized and existing under the Laws of the State of Florida, (hereinafter called OWNER)

and _____
(hereinafter called CONTRACTOR).

OWNER and CONTRACTOR, in consideration of the mutual covenants hereinafter set forth, agree as follows:

ARTICLE 1 - WORK

1.01 CONTRACTOR shall complete all Work as specified or indicated in the Contract Documents. The Work is generally described as follows:

Installation of two pavilions: (1) 30' by 30' pavilion with a concrete floor and (1) 24' by 24' pavilion with a stabilized pervious floor. An Add/Alternate option is requested for stabilized pervious floor in the 30' x 30' pavilion.

Work will include permitting, any required survey, any required earthwork, construction of the two pavilions; and any follow up materials and procedures required to complete the permitting and close-out the project.

ARTICLE 2 - THE PROJECT

2.01 The Project for which the Work under the Contract Documents may be the whole or only a part is generally described as follows:

Project Name:	<u>Hallstrom Farmstead Pavilions</u>
FM Number:	<u>N/A</u>
Bid Number:	<u>2022002</u>
Project Address:	<u>1723 Old Dixie Highway, Vero Beach, FL 32960</u>

ARTICLE 3 - ENGINEER

3.01 The Indian River County Parks and Recreation Division is hereinafter called the ENGINEER and will act as OWNER's representative, assume all duties and responsibilities, and have the rights and authority assigned to ENGINEER in the Contract Documents in connection with the completion of the Work in accordance with the Contract Documents.

ARTICLE 4 - CONTRACT TIMES

4.01 *Time of the Essence*

A. All time limits for Milestones, if any, Substantial Completion, and completion and readiness for final payment as stated in the Contract Documents are of the essence of the Contract.

4.02 *Days to Achieve Substantial Completion, Final Completion and Final Payment*

A. The Work will be substantially completed on or before the **90** calendar day after the date when the Contract Times commence to run as provided in paragraph 2.03 of the General

Conditions, and completed and ready for final payment in accordance with paragraph 14.07 of the General Conditions on or before the **120** calendar day after the date when the Contract Times commence to run.

4.03 *Liquidated Damages*

- A. CONTRACTOR and OWNER recognize that time is of the essence of this Agreement and that OWNER will suffer financial loss if the Work is not completed within the times specified in paragraph 4.02 above, plus any extensions thereof allowed in accordance with Article 12 of the General Conditions. Liquidated damages will commence for this portion of work. The parties also recognize the delays, expense, and difficulties involved in proving in a legal proceeding the actual loss suffered by OWNER if the Work is not completed on time. Accordingly, instead of requiring any such proof, OWNER and CONTRACTOR agree that as liquidated damages for delay (but not as a penalty), CONTRACTOR shall pay OWNER **\$882.00** for each calendar day that expires after the time specified in paragraph 4.02 for Substantial Completion until the Work is substantially complete. After Substantial Completion, if CONTRACTOR shall neglect, refuse, or fail to complete the remaining Work within the Contract Time or any proper extension thereof granted by OWNER, CONTRACTOR shall pay OWNER **\$882.00** for each calendar day that expires after the time specified in paragraph 4.02 for completion and readiness for final payment until the Work is completed and ready for final payment.

ARTICLE 5 - CONTRACT PRICE

5.01 OWNER shall pay CONTRACTOR for completion of the Work in accordance with the Contract Documents, an amount in current funds equal to the sum of the amounts determined pursuant to paragraph 5.01.A and summarized in paragraph 5.01.B, below:

- A. For all Work, at the prices stated in CONTRACTOR's Bid, attached hereto as an exhibit.
- B. THE CONTRACT SUM subject to additions and deductions provided in the Contract:

Numerical Amount: \$ _____

Written Amount: _____

ARTICLE 6 - PAYMENT PROCEDURES

6.01 *Submittal and Processing of Payments*

- A. CONTRACTOR shall submit Applications for Payment in accordance with Article 14 of the General Conditions. Applications for Payment will be processed by OWNER as provided in the General Conditions and the Contract Documents.

6.02 *Progress Payments.*

- A. The OWNER shall make progress payments to the CONTRACTOR on the basis of the approved partial payment request in accordance with the provisions of the Local Government Prompt Payment Act, Florida Statutes section 218.70 et. seq. The OWNER shall retain five percent (5%) of the payment amounts due to the

CONTRACTOR until final completion and acceptance of all work to be performed by CONTRACTOR under the Contract Documents.

6.03 *Pay Requests.*

- A. Each request for a progress payment shall be submitted on the application provided by OWNER and the application for payment shall contain the CONTRACTOR'S certification. All progress payments will be on the basis of progress of the work measured by the schedule of values established, or in the case of unit price work based on the number of units completed.

6.05 *Acceptance of Final Payment as Release.*

- A. The acceptance by the CONTRACTOR of final payment shall be and shall operate as a release to the OWNER from all claims and all liability to the CONTRACTOR other than claims in stated amounts as may be specifically excepted by the CONTRACTOR for all things done or furnished in connection with the work under this Contract and for every act and neglect of the OWNER and others relating to or arising out of the work. Any payment, however, final or otherwise, shall not release the CONTRACTOR or its sureties from any obligations under the Contract Documents or the Public Construction Bond.

ARTICLE 7 - INDEMNIFICATION

7.01 CONTRACTOR shall indemnify OWNER and others in accordance with paragraph 6.20 (*Indemnification*) of the General Conditions to the Construction Contract.

ARTICLE 8 - CONTRACTOR'S REPRESENTATIONS

8.01 In order to induce OWNER to enter into this Agreement CONTRACTOR makes the following representations:

- A. CONTRACTOR has examined and carefully studied the Contract Documents and the other related data identified in the Bidding Documents.
- B. CONTRACTOR has visited the Site and become familiar with and is satisfied as to the general, local, and Site conditions that may affect cost, progress, and performance of the Work.
- C. CONTRACTOR is familiar with and is satisfied as to all federal, state, and local Laws and Regulations that may affect cost, progress, and performance of the Work.
- D. CONTRACTOR has carefully studied all: (1) reports of explorations and tests of subsurface conditions at or contiguous to the Site and all drawings of physical conditions in or relating to existing surface or subsurface structures at or contiguous to the Site (except Underground Facilities) which have been identified in the Supplementary Conditions as provided in paragraph 4.02 of the General Conditions and (2) reports and drawings of a Hazardous Environmental Condition, if any, at the Site which have been identified in the Supplementary Conditions as provided in paragraph 4.06 of the General Conditions.
- E. CONTRACTOR has obtained and carefully studied (or assumes responsibility for having done so) all additional or supplementary examinations, investigations, explorations, tests,

studies, and data concerning conditions (surface, subsurface, and Underground Facilities) at or contiguous to the Site which may affect cost, progress, or performance of the Work or which relate to any aspect of the means, methods, techniques, sequences, and procedures of construction to be employed by CONTRACTOR, including applying the specific means, methods, techniques, sequences, and procedures of construction, if any, expressly required by the Contract Documents to be employed by CONTRACTOR, and safety precautions and programs incident thereto

- F. CONTRACTOR does not consider that any further examinations, investigations, explorations, tests, studies, or data are necessary for the performance of the Work at the Contract Price, within the Contract Times, and in accordance with the other terms and conditions of the Contract Documents.
- G. CONTRACTOR is aware of the general nature of work to be performed by OWNER and others at the Site that relates to the Work as indicated in the Contract Documents.
- H. CONTRACTOR has correlated the information known to CONTRACTOR, information and observations obtained from visits to the Site, reports and drawings identified in the Contract Documents, and all additional examinations, investigations, explorations, tests, studies, and data with the Contract Documents.
- I. CONTRACTOR has given ENGINEER written notice of all conflicts, errors, ambiguities, or discrepancies that CONTRACTOR has discovered in the Contract Documents, and the written resolution thereof by ENGINEER is acceptable to CONTRACTOR.
- J. The Contract Documents are generally sufficient to indicate and convey understanding of all terms and conditions for performance and furnishing of the Work.
- K. Contractor is registered with and will use the Department of Homeland Security's E-Verify system (www.e-verify.gov) to confirm the employment eligibility of all newly hired employees for the duration of this agreement, as required by Section 448.095, F.S. Contractor is also responsible for obtaining proof of E-Verify registration for all subcontractors.

ARTICLE 9 - CONTRACT DOCUMENTS

9.01 *Contents*

- A. The Contract Documents consist of the following:
 - 1. This Agreement (pages 00520-1 to 00520-10, inclusive);
 - 2. Notice to Proceed (page 00550-1);
 - 3. Public Construction Bond (pages 00610-1 to 00610-3, inclusive);
 - 4. Sample Certificate of Liability Insurance (page 00620-1);
 - 5. Contractor's Application for Payment (pages 00622-1 to 00622-6 inclusive);
 - 6. Certificate of Substantial Completion (pages 00630-1 to 00630-2, inclusive);
 - 7. Contractor's Final Certification of the Work (pages 00632-1 to 00632-2, inclusive);

8. Professional Surveyor & Mapper's Certification as to Elevations and Locations of the Work (page 00634-1);
9. General Conditions (pages 00700-1 to 00700-37, inclusive);
10. Supplementary Conditions (pages 00800-i to 00800-12, inclusive);
11. Specifications as listed in Division 1 (General Requirements) and Division 2 (Technical Provisions);
12. Drawings consisting of a cover sheet and sheets numbered 1 through _____, inclusive, with each sheet bearing the following general title:N/A;
13. Addenda (if applicable _____);
14. CONTRACTOR'S BID (pages 00310-1 to 00310-8, inclusive);
15. Bid Bond (page 00430-1);
16. Qualifications Questionnaire (page 00456-1 to 00456-3, inclusive);
17. List of Subcontractors (page 00458-1);
18. Sworn Statement Under Section 105.08, Indian River County Code, on Disclosure of Relationships (pages 00452-1 to 00452-2, inclusive);
19. Certification Regarding Prohibition Against Contracting with Scrutinized Companies (page 00460-1);
20. The following which may be delivered or issued on or after the Effective Date of the Agreement and are not attached hereto:
 - a) Written Amendments;
 - b) Work Change Directives;
 - c) Change Order(s);

ARTICLE 10 - MISCELLANEOUS

10.01 *Terms*

- A. Terms used in this Agreement will have the meanings indicated in the General Conditions.

10.02 *Assignment of Contract*

- A. No assignment by a party hereto of any rights under or interests in the Contract will be binding on another party hereto without the written consent of the party sought to be bound; and, specifically but without limitation, moneys that may become due and moneys that are due may not be assigned without such consent (except to the extent that the effect of this restriction may be limited by law), and unless specifically stated to the contrary in any written consent to an assignment, no assignment will release or discharge the assignor from any duty or responsibility under the Contract Documents.

10.03 *Successors and Assigns*

- A. OWNER and CONTRACTOR each binds itself, its partners, successors, assigns, and legal representatives to the other party hereto, its partners, successors, assigns, and legal representatives in respect to all covenants, agreements, and obligations contained in the Contract Documents.

10.04 *Severability*

- A. Any provision or part of the Contract Documents held to be void or unenforceable under any Law or Regulation shall be deemed stricken, and all remaining provisions shall continue to be valid and binding upon OWNER and CONTRACTOR, who agree that the Contract Documents shall be reformed to replace such stricken provision or part thereof with a valid and enforceable provision that comes as close as possible to expressing the intention of the stricken provision.

10.05 *Venue*

- A. This Contract shall be governed by the laws of the State of Florida. Venue for any lawsuit brought by either party against the other party or otherwise arising out of this Contract shall be in Indian River County, Florida, or, in the event of a federal jurisdiction, in the United States District Court for the Southern District of Florida.

10.06 *Public Records Compliance*

- A. Indian River County is a public agency subject to Chapter 119, Florida Statutes. The Contractor shall comply with Florida's Public Records Law. Specifically, the Contractor shall:

- (1) Keep and maintain public records required by the County to perform the service.
- (2) Upon request from the County's Custodian of Public Records, provide the County with a copy of the requested records or allow the records to be inspected or copied within a reasonable time at a cost that does not exceed the cost provided in Chapter 119 or as otherwise provided by law.
- (3) Ensure that public records that are exempt or confidential and exempt from public records disclosure requirements are not disclosed except as authorized by law for the duration of the contract term and following completion of the contract if the contractor does not transfer the records to the County.
- (4) Upon completion of the contract, transfer, at no cost, to the County all public records in possession of the Contractor or keep and maintain public records required by the County to perform the service. If the Contractor transfers all public records to the County upon completion of the contract, the Contractor shall destroy any duplicate public records that are exempt or confidential and exempt from public records disclosure requirements. If the contractor keeps and maintains public records upon completion of the contract, the Contractor shall meet all applicable requirements for retaining public records. All records stored electronically must be provided to the County, upon request from the Custodian of Public Records, in a format that is compatible with the information technology systems of the County.

B. IF THE CONTRACTOR HAS QUESTIONS REGARDING THE APPLICATION OF CHAPTER 119, FLORIDA STATUTES, TO THE CONTRACTOR'S DUTY TO PROVIDE PUBLIC RECORDS RELATING TO THIS CONTRACT, CONTACT THE CUSTODIAN OF PUBLIC RECORDS AT:

(772) 226-1424

publicrecords@ircgov.com

Indian River County Office of the County Attorney

1801 27th Street

Vero Beach, FL 32960

C. Failure of the Contractor to comply with these requirements shall be a material breach of this Agreement.

[The remainder of this page was left blank intentionally]

IN WITNESS WHEREOF, OWNER and CONTRACTOR have signed this Agreement in duplicate. One counterpart each has been delivered to OWNER and CONTRACTOR. All portions of the Contract Documents have been signed or identified by OWNER and CONTRACTOR or on their behalf.

This Agreement will be effective on _____, 2020 (the date the Contract is approved by the Indian River County Board of County Commissioners, which is the Effective Date of the Agreement).

OWNER:

CONTRACTOR:

INDIAN RIVER COUNTY _____

By: _____
TBD, Chairman

By: _____
(Contractor)

By: _____
Jason E. Brown, County Administrator

(CORPORATE SEAL)

Attest _____

APPROVED AS TO FORM AND LEGAL SUFFICIENCY:

By: _____
Dylan Reingold, County Attorney

Address for giving notices:

Jeffrey R. Smith, Clerk of Court and Comptroller

License No. _____
(Where applicable)

Attest: _____
Deputy Clerk

Agent for service of process: _____

Designated Representative:
Name: Elizabeth Powell
Title: Assistant Director, Parks and Conservation Resources
5500 77th Street
Vero Beach, Florida 32967
(772) 226-1873
Facsimile: (772) 589-6119

Designated Representative:
Name: _____
Title: _____
Address: _____

Phone: _____
Facsimile: _____

(If CONTRACTOR is a corporation or a partnership, attach evidence of authority to sign.)

**** END OF SECTION ****

SECTION 00550 - Notice to Proceed

Dated

TO:

(BIDDER)

ADDRESS:

Contract For:

Hallstrom Farmstead Pavilions

(Insert name of Contract as it appears in the Contract Documents)

FM No: N/A
IRC Bid No. 2020xxx

=====
=====
You are notified that the Contract Times under the above contract will commence to run on _____. By that date, you are to start performing your obligations under the Contract Documents. The contract has allocated **90** calendar days for Substantial Completion of this project and **120** calendar days for Final Completion. In accordance with Article 4 of the Agreement the date of Substantial Completion is _____ and the date of readiness for final payment is _____.

CONTRACTOR shall not commence work under this Contract until he has obtained all insurance required under Article 5 and such insurance has been delivered to the OWNER and approved by the OWNER, nor shall the CONTRACTOR allow any Subcontractor to commence work on his subcontract until all similar insurance required of the Subcontractor has been so obtained and approved. All such insurance shall remain in effect until final payment and at all times thereafter when CONTRACTOR may be correcting, removing or replacing *defective* Work in accordance with Article 13.

Also, before you may start any Work at the Site, you must:
(add other requirements, if applicable)

INDIAN RIVER COUNTY
(OWNER)

By: _____
(AUTHORIZED SIGNATURE)

(TITLE)

SECTION 00610 - Public Construction Bond

INSTRUCTION FOR PUBLIC CONSTRUCTION BOND

The front or cover page to the required public construction payment and performance bond shall contain the information required by Fla. Stat. 255.05(1)(a), and be substantially in the format shown on the first page following this instruction.

The Public Construction Bond shall be in the form suggested by Fla. Stat. 255.05(3) as shown on the second page following this instruction.

A Power of Attorney from a surety insurer authorized to do business in Florida, authorizing the signature of the Attorney in Fact who executes the Public Construction Bond shall accompany that Bond.

**Public Work
F.S. Chapter 255.05 (1)(a)
Cover Page**

THIS BOND IS GIVEN TO COMPLY WITH SECTION 255.05 OR SECTION 713.23 FLORIDA STATUTES, AND ANY ACTION INSTITUTED BY A CLAIMANT UNDER THIS BOND FOR PAYMENT MUST BE IN ACCORDANCE WITH THE NOTICE AND TIME LIMITATION PROVISIONS IN SECTION 255.05(2) OR SECTION 713.23 FLORIDA STATUTES.

BOND NO: _____

CONTRACTOR NAME: _____

CONTRACTOR ADDRESS: _____

CONTRACTOR PHONE NO: _____

SURETY COMPANY NAME: _____

SURETY PRINCIPAL
BUSINESS ADDRESS: _____

SURETY PHONE NO: _____

OWNER NAME: _____

OWNER ADDRESS: _____

OWNER PHONE NO: _____

OBLIGEE NAME: _____
(If contracting entity is different from
the owner, the contracting public entity)

OBLIGEE ADDRESS: _____

OBLIGEE PHONE NO: _____

BOND AMOUNT: _____

CONTRACT NO: _____
(If applicable)

DESCRIPTION OF WORK: _____

PROJECT LOCATION: _____

LEGAL DESCRIPTION: _____
(If applicable)

FRONT PAGE

All other bond page(s) are deemed subsequent to this page regardless of any page number(s) that may be printed thereon.

PUBLIC CONSTRUCTION BOND

Bond No. _____
(enter bond number)

BY THIS BOND, We _____, as Principal and _____, a corporation, as Surety, are bound to _____, herein called Owner, in the sum of \$_____, for payment of which we bind ourselves, our heirs, personal representatives, successors, and assigns, jointly and severally.

THE CONDITION OF THIS BOND is that if Principal:

1. Performs the contract dated _____, _____, between Principal and Owner for construction of _____, the contract being made a part of this bond by reference, at the times and in the manner prescribed in the contract; and
2. Promptly makes payments to all claimants, as defined in Section [255.05\(1\)](#), Florida Statutes, supplying Principal with labor, materials, or supplies, used directly or indirectly by Principal in the prosecution of the work provided for in the contract; and
3. Pays Owner all losses, damages, expenses, costs, and attorney's fees, including appellate proceedings, that Owner sustains because of a default by Principal under the contract; and
4. Performs the guarantee of all work and materials furnished under the contract for the time specified in the contract, then this bond is void; otherwise it remains in full force.

Any action instituted by a claimant under this bond for payment must be in accordance with the notice and time limitation provisions in Section [255.05\(2\)](#), Florida Statutes.

Any changes in or under the contract documents and compliance or noncompliance with any formalities connected with the contract or the changes does not affect Surety's obligation under this bond.

DATED ON _____,

(Name of Principal)

By _____
(As Attorney in Fact)

(Name of Surety)

SECTION 00620 - Sample Certificate of Liability Insurance

CERTIFICATE OF LIABILITY INSURANCE	
PRODUCER	THIS CERTIFICATE IS ISSUED AS A MATTER OF INFORMATION ONLY AND CONFERS NO RIGHTS UPON THE CERTIFICATE HOLDER. THIS CERTIFICATE DOES NOT AMEND, EXTEND OR ALTER THE COVERAGE AFFORDED BY THE POLICIES BELOW.
	COMPANIES AFFORDING COVERAGE
INSURED	COMPANY A -
	COMPANY B -
	COMPANY C -
	COMPANY D -
	COMPANY E -

COVERAGES

THIS IS TO CERTIFY THAT THE POLICIES OF INSURANCE LISTED BELOW HAVE BEEN ISSUED TO THE INSURED NAMED ABOVE FOR THE POLICY PERIOD INDICATED NOTWITHSTANDING ANY REQUIREMENT TERM OR CONDITION OF ANY CONTRACT OR OTHER DOCUMENT WITH RESPECT TO WHICH THIS CERTIFICATE MAY BE ISSUED OR MAY PERTAIN THE INSURANCE ACCORDED BY THE POLICIES DESCRIBED HEREIN IS SUBJECT TO ALL THE TERMS, EXCLUSIONS AND CONDITIONS OF SUCH POLICIES. LIMITS SHOWN MAY HAVE BEEN REDUCED BY PAID CLAIMS.

INSR LTR	TYPE OF INSURANCE	POLICY NUMBER	POLICY EFFECTIVE DATE (MM/DD/YY)	POLICY EXPIRATION DATE (MM/D/YY)	LIMITS		
A	GENERAL LIABILITY <input type="checkbox"/> COMMERCIAL GENERAL LIABILITY <input type="checkbox"/> CLAIMS MADE - <input type="checkbox"/> OCCUR <input type="checkbox"/> <input type="checkbox"/> <input type="checkbox"/> <input type="checkbox"/>				EACH OCCURRENCE	\$ 1,000,000	
					FIRE DAMAGE (Any One Fire)	\$ 50,000	
					MED. EXP. (Any One Person)	\$ 5,000	
					PERSONAL & ADV INJURY	\$ 1,000,000	
					GENERAL AGGREGATE	\$ 1,000,000	
					PRODUCTS – COMP/OP AGG.	\$ 1,000,000	
						\$	
A	AUTOMOBILE LIABILITY <input type="checkbox"/> ANY AUTO <input type="checkbox"/> ALL OWNED AUTOS <input type="checkbox"/> SCHEDULED AUTOS <input type="checkbox"/> HIRED AUTOS <input type="checkbox"/> NON-OWNED AUTOS <input type="checkbox"/> <input type="checkbox"/>				COMBINED SINGLE LIMIT (Ea. Occurrence)	\$ 1,000,000	
					BODILY INJURY (Per Person)	\$	
					BODILY INJURY (Per Accident)	\$	
					PROPERTY DAMAGE	\$	
	GARAGE LIABILITY <input type="checkbox"/> <input type="checkbox"/>				AUTO ONLY – EA ACCIDENT	\$	
					OTHER THAN	EA ACC	\$
						AUTO ONLY	AGG
A	EXCESS LIABILITY <input type="checkbox"/> CLAIMS MADE <input type="checkbox"/> DEDUCTIBLE <input type="checkbox"/> RETENTION \$				EACH OCCURRENCE		
					AGGREGATE	\$	
						\$	
						\$	
A	WORKER'S COMPENSATION AND EMPLOYER'S LIABILITY THE PROPRIETOR/PARTNERS/ EXECUTIVE OFFICERS ARE: <input type="checkbox"/> INCL <input type="checkbox"/> EXCL				<input type="checkbox"/> WC STATUTORY LIMITS		
					E.L. EACH ACCIDENT	\$ 100,000	
					E.L. DISEASE – EA	\$ 500,000	
					E.L. DISEASE-POLICY LIMIT	\$ 100,000	
	OTHER: BUILDER'S RISK				FULL REPLACEMENT COST OF THE WORK		

DESCRIPTION OF OPERATIONS/LOCATIONS VEHICLES/SPECIAL ITEMS

CERTIFICATE HOLDER	ADDITIONAL INSURED; INSURER LETTER:	CANCELLATION
ADDITIONAL INSURED: INDIAN RIVER COUNTY 1801 27 TH STREET, VERO BEACH, FL 32960-3388		SHOULD ANY OF THE ABOVE DESCRIBED POLICIES BE CANCELLED BEFORE THE EXPIRATION DATE THEREOF, THE ISSUING COMPANY WILL ENDEAVOR TO MAIL 30 DAYS WRITTEN NOTICE TO THE CERTIFICATE HOLDER NAMED TO THE LEFT. FAILURE TO MAIL SUCH NOTICE SHALL IMPOSE NO OBLIGATION OR LIABILITY OF ANY KIND UPON THE COMPANY, ITS AGENTS OR REPRESENTATIVES.
		AUTHORIZED REPRESENTATIVE

Dated _____

By: _____
(CONTRACTOR – must be signed by
an Officer of the Corporation)

Print Name and Title

STATE OF _____

COUNTY OF _____

Sworn to (or affirmed) and subscribed before me by means of physical presence or online
notarization, this _____ day of _____ 20____, by _____
(name of person making statement).

(Signature of Notary Public - State of Florida)
(Print, Type, or Stamp Commissioned Name of Notary Public)

who is personally known to me or who has produced
_____ as identification.

Please remit payment to:

Contractor's Name: _____

Address: _____

[The remainder of this page was left blank intentionally]

SURETY'S CONSENT OF PAYMENT TO CONTRACTOR:

The Surety, _____

_____, a
corporation, in accordance with Public Construction Bond Number _____, hereby
consents to payment by the OWNER to the CONTRACTOR, for the amounts specified in
this CONTRACTOR's APPLICATION FOR PAYMENT.

TO BE EXECUTED BY CORPORATE SURETY:

Attest:

Secretary

Corporate Surety

Business Address

BY: _____

Print Name: _____

Title: _____

(Affix Corporate SEAL)

STATE OF FLORIDA
COUNTY OF INDIAN RIVER

Before me, a Notary Public, duly commissioned, qualified, and acting, personally appeared
_____, to me well known or who produced
_____ as identification, who being by me first duly sworn
upon oath, says that he/she is the _____ for
and that he/she has been authorized by _____ it to approve payment by the OWNER
to the CONTRACTOR of the foregoing Contractor's Application for Payment. Subscribed and
sworn to before me this ____ day of _____, 20____.

Notary Public, State of _____

My Commission Expires: _____

[The remainder of this page was left blank intentionally]

CERTIFICATION OF PROJECT MANAGER:

I certify that I have reviewed the above and foregoing Periodic Estimate for Partial Payment; that to the best of my knowledge and belief it appears to be a reasonably accurate statement of the work performed and/or material supplied by the Contractor. I am not certifying as to whether or not the Contractor has paid all subcontractors, laborers, materialmen and suppliers because I am not in a position to accurately determine that issue.

Dated _____

SIGNATURE

CERTIFICATION OF INSPECTOR:

I have checked the estimate against the Contractor's Schedule of Amounts for Contract Payments and the notes and reports of my inspections of the project. To the best of my knowledge, this statement of work performed and/or materials supplied appears to be reasonably accurate, that the Contractor appears to be observing the requirements of the Contract with respect to construction, and that the Contractor should be paid the amount requested above, unless otherwise noted by me. I am not certifying as to whether or not the Contractor has paid all subcontractors, laborers, materialmen and suppliers because I am not in a position to accurately determine that issue.

Dated _____

SIGNATURE

[The Remainder of This Page Was Left Blank Intentionally]

SECTION 00630 - Certificate of Substantial Completion

Date of Issuance: _____, 20____

OWNER: Indian River County
CONTRACTOR: _____
CONTRACT FOR: Hallstrom Farmstead Pavilions

FM No.: N/A
Project Description: **Construction of two picnic pavilions**
OWNER's Bid No. 2022002

This Certificate of Substantial Completion applies to all Work under the Contract Documents or to the following specified parts thereof:

To: _____
OWNER

And To: _____
CONTRACTOR

The Work to which this Certificate applies has been inspected by authorized representatives of OWNER, CONTRACTOR and ENGINEER, and that Work is hereby declared to be substantially complete in accordance with the Contract Documents on

DATE OF SUBSTANTIAL COMPLETION

A tentative list of items to be completed or corrected is attached hereto. This list may not be all-inclusive, and the failure to include an item in it does not alter the responsibility of CONTRACTOR to complete all the Work in accordance with the Contract Documents. The items in the tentative list shall be completed or corrected by CONTRACTOR within 30 calendar days of the above date of Substantial Completion.

The responsibilities between OWNER and CONTRACTOR for security, operation, safety, maintenance, heat, utilities, insurance and warranties and guarantees shall be as follows:

OWNER:

CONTRACTOR:

The following documents are attached to and made a part of this Certificate:

[For items to be attached see definition of Substantial Completion as supplemented and other specifically noted conditions precedent to achieving Substantial Completion as required by Contract Documents.]

This certificate does not constitute an acceptance of Work not in accordance with the Contract Documents nor is it a release of CONTRACTOR's obligation to complete the Work in accordance with the Contract Documents.

Executed by ENGINEER on: _____ (Date).

ENGINEER: _____

By: _____
(Authorized Signature)

CONTRACTOR accepts this Certificate of Substantial Completion on _____ (date).

CONTRACTOR: _____

By: _____
(Authorized Signature)

OWNER accepts this Certificate of Substantial Completion on _____ (date).

OWNER: INDIAN RIVER COUNTY _____

By: _____
(Authorized Signature)

*** * END OF SECTION * ***

**SECTION 00632 - CONTRACTOR'S FINAL CERTIFICATION OF
THE WORK**
(TO ACCOMPANY CONTRACTOR'S FINAL APPLICATION FOR PAYMENT)

PROJECT NAME: Hallstrom Farmstead Pavilions

BID NO: 2022022

STATE OF _____
COUNTY OF _____

Personally before me the undersigned officer, authorized by the laws of said state to administer oaths, comes _____, who on oath says: That he is the CONTRACTOR with whom Indian River County, Florida, a political subdivision of said state, did on the _____ day of _____, 20____, enter into a contract for the performance of certain work, more particularly described as follows:

UNDER PENALTY OF PERJURY, affiant further says that said construction has been completed and the Contract therefore fully performed and final payment is now due and that all liens of all firms and individuals contracting directly with or directly employed by such CONTRACTOR have been paid in full EXCEPT:

Name	Description/Amount
_____	_____
_____	_____

who have not been paid and who are due the amount set forth.

Affiant further says that:

1. CONTRACTOR has reviewed the Contract Documents.
2. CONTRACTOR has reviewed the Work for compliance with the Contract Documents.
3. CONTRACTOR has completed the Work in accordance with the Contract Documents.
4. All equipment and systems have been tested in the presence of the ENGINEER or his representative and are fully operational with no defects or deficiencies except as listed below.

- 5. The Work is complete and ready for final acceptance by the OWNER.
- 6. CONTRACTOR hereby certifies that it has no claims against the OWNER.

(Corporate Seal)

(Contractor)

By: _____

STATE OF _____

COUNTY OF _____

Sworn to (or affirmed) and subscribed before me by means of physical presence or online notarization, this _____ day of _____ 20____, by _____
(name of person making statement).

(Signature of Notary Public - State of Florida)
(Print, Type, or Stamp Commissioned Name of Notary Public)

who is personally known to me or who has produced
_____ as identification.

+ + END OF SECTION + +

SECTION 00634 - PROFESSIONAL SURVEYOR AND MAPPER'S CERTIFICATION AS TO ELEVATIONS AND LOCATIONS OF THE WORK

(TO BE COMPLETED BY A FLORIDA PROFESSIONAL SURVEYOR AND MAPPER RETAINED BY THE CONTRACTOR AND TO ACCOMPANY CONTRACTOR'S FINAL APPLICATION FOR PAYMENT)

I CERTIFY that I am a Florida Professional Surveyor and Mapper retained by:

(Insert name of CONTRACTOR)

Who is the CONTRACTOR for the following Project:

PROJECT NAME: Hallstrom Farmstead Pavilions

Bid # 2022022

I FURTHER CERTIFY that I have personally performed the survey work for the preparation of Record Drawings for the CONTRACTOR for this project or that such work was performed under my direct control and supervision.

I FURTHER CERTIFY that all constructed elevations and locations of the Work are in conformance with the Contract Documents, except for discrepancies listed below.

[Attach additional sheets as necessary]

(SURVEYOR'S SEAL)

CERTIFIED BY: _____

Printed Name: _____

Florida Professional Surveyor and Mapper Registration Number: _____

Date Signed and Sealed by Professional Surveyor and Mapper: _____

Company Name: _____

Company Address: _____

Telephone Number: _____

STANDARD
GENERAL CONDITIONS
OF THE
CONSTRUCTION CONTRACT

Prepared by

ENGINEERS JOINT CONTRACT DOCUMENTS COMMITTEE

and

Issued and Published Jointly By

PROFESSIONAL ENGINEERS IN PRIVATE PRACTICE
a practice division of the
NATIONAL SOCIETY OF PROFESSIONAL ENGINEERS

AMERICAN CONSULTING ENGINEERS COUNCIL

AMERICAN SOCIETY OF CIVIL ENGINEERS

This document has been approved and endorsed by

The Associated General Contractors of America

Construction Specifications Institute

Copyright ©1996

National Society of Professional Engineers
1420 King Street, Alexandria, VA 22314

American Consulting Engineers Council
1015 15th Street N.W., Washington, DC 20005

American Society of Civil Engineers
345 East 47th Street, New York, NY 10017

TABLE OF CONTENTS

Title	Page
ARTICLE 1 - DEFINITIONS AND TERMINOLOGY	1
1.01 <i>Defined Terms</i>	1
1.02 <i>Terminology</i>	3
ARTICLE 2 - PRELIMINARY MATTERS	4
2.01 <i>Delivery of Bonds</i>	4
2.02 <i>Copies of Documents</i>	4
2.03 <i>Commencement of Contract Times; Notice to Proceed</i>	4
2.04 <i>Starting the Work</i>	4
2.05 <i>Before Starting Construction</i>	4
2.06 <i>Preconstruction Conference</i>	5
2.07 <i>Initial Acceptance of Schedules</i>	5
ARTICLE 3 - CONTRACT DOCUMENTS: INTENT, AMENDING, REUSE.....	5
3.01 <i>Intent</i>	5
3.02 <i>Reference Standards</i>	5
3.03 <i>Reporting and Resolving Discrepancies</i>	6
3.04 <i>Amending and Supplementing Contract Documents</i>	6
3.05 <i>Reuse of Documents</i>	6
ARTICLE 4 - AVAILABILITY OF LANDS; SUBSURFACE AND PHYSICAL CONDITIONS; REFERENCE POINTS.....	6
4.01 <i>Availability of Lands</i>	6
4.02 <i>Subsurface and Physical Conditions</i>	6
4.03 <i>Differing Subsurface or Physical Conditions</i>	7
4.04 <i>Underground Facilities</i>	8
4.05 <i>Reference Points</i>	8
4.06 <i>Hazardous Environmental Condition at Site</i>	8
ARTICLE 5 - BONDS AND INSURANCE.....	10
5.01 <i>Performance, Payment, and Other Bonds</i>	10
5.02 <i>Licensed Sureties and Insurers</i>	10
5.03 <i>Certificates of Insurance</i>	10
5.04 <i>CONTRACTOR'S Liability Insurance</i>	10
5.05 <i>OWNER'S Liability Insurance</i>	11
5.06 <i>Property Insurance</i>	11
5.07 <i>Waiver of Rights</i>	12
5.08 <i>Receipt and Application of Insurance Proceeds</i>	13
5.09 <i>Acceptance of Bonds and Insurance; Option to Replace</i>	13
5.10 <i>Partial Utilization, Acknowledgment of Property Insurer</i>	13
ARTICLE 6 - CONTRACTOR'S RESPONSIBILITIES	13
6.01 <i>Supervision and Superintendence</i>	13
6.02 <i>Labor; Working Hours</i>	14
6.03 <i>Services, Materials, and Equipment</i>	14
6.04 <i>Progress Schedule</i>	14
6.05 <i>Substitutes and "Or-Equals"</i>	14
6.06 <i>Concerning Subcontractors, Suppliers, and Others</i>	15
6.07 <i>Patent Fees and Royalties</i>	16
6.08 <i>Permits</i>	16
6.09 <i>Laws and Regulations</i>	17
6.10 <i>Taxes</i>	17
6.11 <i>Use of Site and Other Areas</i>	17

6.12	Record Documents	18
6.13	<i>Safety and Protection</i>	18
6.14	<i>Safety Representative</i>	18
6.15	<i>Hazard Communication Programs</i>	18
6.16	<i>Emergencies</i>	18
6.17	<i>Shop Drawings and Samples</i>	18
6.18	<i>Continuing the Work</i>	20
6.19	<i>CONTRACTOR's General Warranty and Guarantee</i>	20
6.20	<i>Indemnification</i>	20
ARTICLE 7 - OTHER WORK		21
7.01	<i>Related Work at Site</i>	21
7.02	<i>Coordination</i>	21
ARTICLE 8 - OWNER'S RESPONSIBILITIES		21
8.01	<i>Communications to Contractor</i>	21
8.02	<i>Replacement of ENGINEER</i>	21
8.03	<i>Furnish Data</i>	21
8.04	<i>Pay Promptly When Due</i>	22
8.05	<i>Lands and Easements; Reports and Tests</i>	22
8.06	<i>Insurance</i>	22
8.07	<i>Change Orders</i>	22
8.08	<i>Inspections, Tests, and Approvals</i>	22
8.09	<i>Limitations on OWNER's Responsibilities</i>	22
8.10	<i>Undisclosed Hazardous Environmental Condition</i>	22
8.11	<i>Evidence of Financial Arrangements</i>	22
ARTICLE 9 - ENGINEER'S STATUS DURING CONSTRUCTION.....		22
9.01	<i>OWNER'S Representative</i>	22
9.02	<i>Visits to Site</i>	22
9.03	<i>Project Representative</i>	22
9.04	<i>Clarifications and Interpretations</i>	23
9.05	<i>Authorized Variations in Work</i>	23
9.06	<i>Rejecting Defective Work</i>	23
9.07	<i>Shop Drawings, Change Orders and Payments</i>	23
9.08	<i>Determinations for Unit Price Work</i>	23
9.09	<i>Decisions on Requirements of Contract Documents and Acceptability of Work</i>	23
9.10	<i>Limitations on ENGINEER's Authority and Responsibilities</i>	23
ARTICLE 10 - CHANGES IN THE WORK; CLAIMS.....		24
10.01	<i>Authorized Changes in the Work</i>	24
10.02	<i>Unauthorized Changes in the Work</i>	24
10.03	<i>Execution of Change Orders</i>	24
10.04	<i>Notification to Surety</i>	24
10.05	<i>Claims and Disputes</i>	24
ARTICLE 11 - COST OF THE WORK; CASH ALLOWANCES; UNIT PRICE WORK		25
11.01	<i>Cost of the Work</i>	25
11.02	<i>Cash Allowances</i>	27
11.03	<i>Unit Price Work</i>	27
ARTICLE 12 - CHANGE OF CONTRACT PRICE; CHANGE OF CONTRACT TIMES		27
12.01	<i>Change of Contract Price</i>	27
12.02	<i>Change of Contract Times</i>	28
12.03	<i>Delays Beyond CONTRACTOR's Control</i>	28
12.04	<i>Delays Within CONTRACTOR's Control</i>	28
12.05	<i>Delays Beyond OWNER's and CONTRACTOR's Control</i>	28
12.06	<i>Delay Damages</i>	29

ARTICLE 13 - TESTS AND INSPECTIONS; CORRECTION, REMOVAL OR ACCEPTANCE OF DEFECTIVE WORK.....	29
13.01 <i>Notice of Defects</i>	29
13.02 <i>Access to Work</i>	29
13.03 <i>Tests and Inspections</i>	29
13.04 <i>Uncovering Work</i>	30
13.05 <i>OWNER May Stop the Work</i>	30
13.06 <i>Correction or Removal of Defective Work</i>	30
13.07 <i>Correction Period</i>	30
13.08 <i>Acceptance of Defective Work</i>	31
13.09 <i>OWNER May Correct Defective Work</i>	31
 ARTICLE 14 - PAYMENTS TO CONTRACTOR AND COMPLETION.....	 31
14.01 <i>Schedule of Values</i>	31
14.02 <i>Progress Payments</i>	31
14.03 <i>CONTRACTOR's Warranty of Title</i>	33
14.04 <i>Substantial Completion</i>	33
14.05 <i>Partial Utilization</i>	34
14.06 <i>Final Inspection</i>	34
14.07 <i>Final Payment</i>	34
14.08 <i>Final Completion Delayed</i>	35
14.09 <i>Waiver of Claims</i>	35
 ARTICLE 15 - SUSPENSION OF WORK AND TERMINATION.....	 35
15.01 <i>OWNER May Suspend Work</i>	35
15.02 <i>OWNER May Terminate for Cause</i>	35
15.03 <i>OWNER May Terminate For Convenience</i>	36
15.04 <i>CONTRACTOR May Stop Work or Terminate</i>	36
 ARTICLE 16 - DISPUTE RESOLUTION.....	 36
16.01 <i>Methods and Procedures</i>	36
 ARTICLE 17 - MISCELLANEOUS.....	 37
17.01 <i>Giving Notice</i>	37
17.02 <i>Computation of Times</i>	37
17.03 <i>Cumulative Remedies</i>	37
17.04 <i>Survival of Obligations</i>	37
17.05 <i>Controlling Law</i>	37

GENERAL CONDITIONS

ARTICLE 1 - DEFINITIONS AND TERMINOLOGY

1.01 *Defined Terms*

A. Wherever used in the Contract Documents and printed with initial or all capital letters, the terms listed below will have the meanings indicated which are applicable to both the singular and plural thereof.

1. *Addenda*--Written or graphic instruments issued prior to the opening of Bids which clarify, correct, or change the Bidding Requirements or the Contract Documents.

2. *Agreement*--The written instrument which is evidence of the agreement between OWNER and CONTRACTOR covering the Work.

3. *Application for Payment*--The form acceptable to ENGINEER which is to be used by CONTRACTOR during the course of the Work in requesting progress or final payments and which is to be accompanied by such supporting documentation as is required by the Contract Documents.

4. *Asbestos*--Any material that contains more than one percent asbestos and is friable or is releasing asbestos fibers into the air above current action levels established by the United States Occupational Safety and Health Administration.

5. *Bid*--The offer or proposal of a bidder submitted on the prescribed form setting forth the prices for the Work to be performed.

6. *Bidding Documents*--The Bidding Requirements and the proposed Contract Documents (including all Addenda issued prior to receipt of Bids).

7. *Bidding Requirements*--The Advertisement or Invitation to Bid, Instructions to Bidders, Bid security form, if any, and the Bid form with any supplements.

8. *Bonds*--Performance and payment bonds and other instruments of security.

9. *Change Order*--A document recommended by ENGINEER which is signed by CONTRACTOR and OWNER and authorizes an addition, deletion, or revision in the Work or an adjustment in the Contract Price or the Contract Times, issued on or after the Effective Date of the Agreement.

10. *Claim*--A demand or assertion by OWNER or CONTRACTOR seeking an adjustment of Contract Price or Contract Times, or both, or other relief with respect to the terms of the Contract. A

demand for money or services by a third party is not a Claim.

11. *Contract*--The entire and integrated written agreement between the OWNER and CONTRACTOR concerning the Work. The Contract supersedes prior negotiations, representations, or agreements, whether written or oral.

12. *Contract Documents*--The Contract Documents establish the rights and obligations of the parties and include the Agreement, Addenda (which pertain to the Contract Documents), CONTRACTOR's Bid (including documentation accompanying the Bid and any post Bid documentation submitted prior to the Notice of Award) when attached as an exhibit to the Agreement, the Notice to Proceed, the Bonds, these General Conditions, the Supplementary Conditions, the Specifications and the Drawings as the same are more specifically identified in the Agreement, together with all Written Amendments, Change Orders, Work Change Directives, Field Orders, and ENGINEER's written interpretations and clarifications issued on or after the Effective Date of the Agreement. Approved Shop Drawings and the reports and drawings of subsurface and physical conditions are not Contract Documents. Only printed or hard copies of the items listed in this paragraph are Contract Documents. Files in electronic media format of text, data, graphics, and the like that may be furnished by OWNER to CONTRACTOR are not Contract Documents.

13. *Contract Price*--The moneys payable by OWNER to CONTRACTOR for completion of the Work in accordance with the Contract Documents as stated in the Agreement (subject to the provisions of paragraph 11.03 in the case of Unit Price Work).

14. *Contract Times*--The number of days or the dates stated in the Agreement to: (i) achieve Substantial Completion; and (ii) complete the Work so that it is ready for final payment as evidenced by ENGINEER's written recommendation of final payment.

15. *CONTRACTOR*--The individual or entity with whom OWNER has entered into the Agreement.

16. *Cost of the Work*--See paragraph 11.01.A for definition.

17. *Drawings*--That part of the Contract Documents prepared or approved by ENGINEER which graphically shows the scope, extent, and character of the Work to be performed by CONTRACTOR. Shop Drawings and other CONTRACTOR submittals are not Drawings as so defined.

18. *Effective Date of the Agreement*--The date indicated in the Agreement on which it becomes effective, but if no such date is indicated, it means the date on which the Agreement is signed and delivered by the last of the two parties to sign and deliver.

19. *ENGINEER*--The individual or entity named as such in the Agreement.

20. *ENGINEER's Consultant*--An individual or entity having a contract with ENGINEER to furnish services as ENGINEER's independent professional associate or consultant with respect to the Project and who is identified as such in the Supplementary Conditions.

~~21. *Field Order*--A written order issued by ENGINEER which requires minor changes in the Work but which does not involve a change in the Contract Price or the Contract Times.~~

22. *General Requirements*--Sections of Division 1 of the Specifications. The General Requirements pertain to all sections of the Specifications.

23. *Hazardous Environmental Condition*--The presence at the Site of Asbestos, PCBs, Petroleum, Hazardous Waste, or Radioactive Material in such quantities or circumstances that may present a substantial danger to persons or property exposed thereto in connection with the Work.

24. *Hazardous Waste*--The term Hazardous Waste shall have the meaning provided in Section 1004 of the Solid Waste Disposal Act (42 USC Section 6903) as amended from time to time.

25. *Laws and Regulations; Laws or Regulations*--Any and all applicable laws, rules, regulations, ordinances, codes, and orders of any and all governmental bodies, agencies, authorities, and courts having jurisdiction.

26. *Liens*--Charges, security interests, or encumbrances upon Project funds, real property, or personal property.

27. *Milestone*--A principal event specified in the Contract Documents relating to an intermediate completion date or time prior to Substantial Completion of all the Work.

28. *Notice of Award*--The written notice by OWNER to the apparent successful bidder stating that upon timely compliance by the apparent successful bidder with the conditions precedent listed therein, OWNER will sign and deliver the Agreement.

29. *Notice to Proceed*--A written notice given by OWNER to CONTRACTOR fixing the date on which the Contract Times will commence to run and on which

CONTRACTOR shall start to perform the Work under the Contract Documents.

30. *OWNER*--The individual, entity, public body, or authority with whom CONTRACTOR has entered into the Agreement and for whom the Work is to be performed.

31. *Partial Utilization*--Use by OWNER of a substantially completed part of the Work for the purpose for which it is intended (or a related purpose) prior to Substantial Completion of all the Work.

32. *PCBs*--Polychlorinated biphenyls.

33. *Petroleum*--Petroleum, including crude oil or any fraction thereof which is liquid at standard conditions of temperature and pressure (60 degrees Fahrenheit and 14.7 pounds per square inch absolute), such as oil, petroleum, fuel oil, oil sludge, oil refuse, gasoline, kerosene, and oil mixed with other non-Hazardous Waste and crude oils.

34. *Project*--The total construction of which the Work to be performed under the Contract Documents may be the whole, or a part as may be indicated elsewhere in the Contract Documents.

35. *Project Manual*--The bound documentary information prepared for bidding and constructing the Work. A listing of the contents of the Project Manual, which may be bound in one or more volumes, is contained in the table(s) of contents.

36. *Radioactive Material*--Source, special nuclear, or byproduct material as defined by the Atomic Energy Act of 1954 (42 USC Section 2011 et seq.) as amended from time to time.

37. *Resident Project Representative*--The authorized representative of ENGINEER who may be assigned to the Site or any part thereof.

38. *Samples*--Physical examples of materials, equipment, or workmanship that are representative of some portion of the Work and which establish the standards by which such portion of the Work will be judged.

39. *Shop Drawings*--All drawings, diagrams, illustrations, schedules, and other data or information which are specifically prepared or assembled by or for CONTRACTOR and submitted by CONTRACTOR to illustrate some portion of the Work.

40. *Site*--Lands or areas indicated in the Contract Documents as being furnished by OWNER upon which the Work is to be performed, including rights-of-way and easements for access thereto, and such other lands furnished by OWNER which are designated for the use of CONTRACTOR.

41. *Specifications*--That part of the Contract Documents consisting of written technical descriptions of materials, equipment, systems, standards, and workmanship as applied to the Work and certain administrative details applicable thereto.

42. *Subcontractor*--An individual or entity having a direct contract with CONTRACTOR or with any other Subcontractor for the performance of a part of the Work at the Site.

43. *Substantial Completion*--The time at which the Work (or a specified part thereof) has progressed to the point where, in the opinion of ENGINEER, the Work (or a specified part thereof) is sufficiently complete, in accordance with the Contract Documents, so that the Work (or a specified part thereof) can be utilized for the purposes for which it is intended. The terms "substantially complete" and "substantially completed" as applied to all or part of the Work refer to Substantial Completion thereof.

44. *Supplementary Conditions*--That part of the Contract Documents which amends or supplements these General Conditions.

45. *Supplier*--A manufacturer, fabricator, supplier, distributor, materialman, or vendor having a direct contract with CONTRACTOR or with any Subcontractor to furnish materials or equipment to be incorporated in the Work by CONTRACTOR or any Subcontractor.

46. *Underground Facilities*--All underground pipelines, conduits, ducts, cables, wires, manholes, vaults, tanks, tunnels, or other such facilities or attachments, and any encasements containing such facilities, including those that convey electricity, gases, steam, liquid petroleum products, telephone or other communications, cable television, water, wastewater, storm water, other liquids or chemicals, or traffic or other control systems.

47. *Unit Price Work*--Work to be paid for on the basis of unit prices.

48. *Work*--The entire completed construction or the various separately identifiable parts thereof required to be provided under the Contract Documents. Work includes and is the result of performing or providing all labor, services, and documentation necessary to produce such construction, and furnishing, installing, and incorporating all materials and equipment into such construction, all as required by the Contract Documents.

49. *Work Change Directive*--A written statement to CONTRACTOR issued on or after the Effective Date of the Agreement and signed by OWNER and recommended by ENGINEER ordering an addition, deletion, or revision in the Work, or responding to differing or unforeseen subsurface or

physical conditions under which the Work is to be performed or to emergencies. A Work Change Directive will not change the Contract Price or the Contract Times but is evidence that the parties expect that the change ordered or documented by a Work Change Directive will be incorporated in a subsequently issued Change Order following negotiations by the parties as to its effect, if any, on the Contract Price or Contract Times.

50. *Written Amendment*--A written statement modifying the Contract Documents, signed by OWNER and CONTRACTOR on or after the Effective Date of the Agreement and normally dealing with the nonengineering or nontechnical rather than strictly construction-related aspects of the Contract Documents.

1.02 Terminology

A. Intent of Certain Terms or Adjectives

1. Whenever in the Contract Documents the terms "as allowed," "as approved," or terms of like effect or import are used, or the adjectives "reasonable," "suitable," "acceptable," "proper," "satisfactory," or adjectives of like effect or import are used to describe an action or determination of ENGINEER as to the Work, it is intended that such action or determination will be solely to evaluate, in general, the completed Work for compliance with the requirements of and information in the Contract Documents and conformance with the design concept of the completed Project as a functioning whole as shown or indicated in the Contract Documents (unless there is a specific statement indicating otherwise). The use of any such term or adjective shall not be effective to assign to ENGINEER any duty or authority to supervise or direct the performance of the Work or any duty or authority to undertake responsibility contrary to the provisions of paragraph 9.10 or any other provision of the Contract Documents.

B. Day

1. The word "day" shall constitute a calendar day of 24 hours measured from midnight to the next midnight.

C. Defective

1. The word "defective," when modifying the word "Work," refers to Work that is unsatisfactory, faulty, or deficient in that it does not conform to the Contract Documents or does not meet the requirements of any inspection, reference standard, test, or approval referred to in the Contract Documents, or has been damaged prior to ENGINEER's recommendation of final payment (unless responsibility for the protection thereof has been

assumed by OWNER at Substantial Completion in accordance with paragraph 14.04 or 14.05).

D. *Furnish, Install, Perform, Provide*

~~1. The word "furnish," when used in connection with services, materials, or equipment, shall mean to supply and deliver said services, materials, or equipment to the Site (or some other specified location) ready for use or installation and in usable or operable condition.~~

~~2. The word "install," when used in connection with services, materials, or equipment, shall mean to put into use or place in final position said services, materials, or equipment complete and ready for intended use.~~

~~3. The words "perform" or "provide," when used in connection with services, materials, or equipment, shall mean to furnish and install said services, materials, or equipment complete and ready for intended use.~~

4. When "furnish," "install," "perform," or "provide" is not used in connection with services, materials, or equipment in a context clearly requiring an obligation of CONTRACTOR, "provide" is implied.

E. Unless stated otherwise in the Contract Documents, words or phrases which have a well-known technical or construction industry or trade meaning are used in the Contract Documents in accordance with such recognized meaning.

ARTICLE 2 - PRELIMINARY MATTERS

2.01 *Delivery of Bonds*

A. When CONTRACTOR delivers the executed Agreements to OWNER, CONTRACTOR shall also deliver to OWNER such Bonds as CONTRACTOR may be required to furnish.

2.02 *Copies of Documents*

A. OWNER shall furnish to CONTRACTOR up to ten copies of the Contract Documents. Additional copies will be furnished upon request at the cost of reproduction.

2.03 *Commencement of Contract Times; Notice to Proceed*

A. The Contract Times will commence to run on the thirtieth day after the Effective Date of the Agreement or, if a Notice to Proceed is given, on the day indicated in the Notice to Proceed. A Notice to Proceed may be given at any time within 30 days after the Effective Date of the Agreement. In no event will the Contract Times commence to run later than the ninetieth day after the day of Bid opening or the thirtieth day after the Effective Date of the Agreement, whichever date is earlier.

2.04 *Starting the Work*

A. CONTRACTOR shall start to perform the Work on the date when the Contract Times commence to run. No Work shall be done at the Site prior to the date on which the Contract Times commence to run.

2.05 *Before Starting Construction*

A. *CONTRACTOR's Review of Contract Documents:* Before undertaking each part of the Work, CONTRACTOR shall carefully study and compare the Contract Documents and check and verify pertinent figures therein and all applicable field measurements. CONTRACTOR shall promptly report in writing to ENGINEER any conflict, error, ambiguity, or discrepancy which CONTRACTOR may discover and shall obtain a written interpretation or clarification from ENGINEER before proceeding with any Work affected thereby; however, CONTRACTOR shall not be liable to OWNER or ENGINEER for failure to report any conflict, error, ambiguity, or discrepancy in the Contract Documents unless CONTRACTOR knew or reasonably should have known thereof.

B. *Preliminary Schedules:* Within ten days after the Effective Date of the Agreement (unless otherwise specified in the General Requirements), CONTRACTOR shall submit to ENGINEER for its timely review:

1. a preliminary progress schedule indicating the times (numbers of days or dates) for starting and completing the various stages of the Work, including any Milestones specified in the Contract Documents;

2. a preliminary schedule of Shop Drawing and Sample submittals which will list each required submittal and the times for submitting, reviewing, and processing such submittal; and

3. a preliminary schedule of values for all of the Work which includes quantities and prices of items which when added together equal the Contract Price and subdivides the Work into component parts in sufficient detail to serve as the basis for progress payments during performance of the Work. Such prices will include an appropriate amount of overhead and profit applicable to each item of Work.

~~C. Evidence of Insurance: Before any Work at the Site is started, CONTRACTOR and OWNER shall each deliver to the other, with copies to each additional insured identified in the Supplementary Conditions, certificates of insurance (and other evidence of insurance which either of them or any additional insured may reasonably request) which CONTRACTOR and OWNER respectively are required to purchase and maintain in accordance with Article 5.~~

2.06 *Preconstruction Conference*

~~A. Within 20 days after the Contract Times start to run, but before any Work at the Site is started, a conference attended by CONTRACTOR, ENGINEER, and others as appropriate will be held to establish a working understanding among the parties as to the Work and to discuss the schedules referred to in paragraph 2.05.B, procedures for handling Shop Drawings and other submittals, processing Applications for Payment, and maintaining required records.~~

2.07 *Initial Acceptance of Schedules*

A. Unless otherwise provided in the Contract Documents, at least ten days before submission of the first Application for Payment a conference attended by CONTRACTOR, ENGINEER, and others as appropriate will be held to review for acceptability to ENGINEER as provided below the schedules submitted in accordance with paragraph 2.05.B. CONTRACTOR shall have an additional ten days to make corrections and adjustments and to complete and resubmit the schedules. No progress payment shall be made to CONTRACTOR until acceptable schedules are submitted to ENGINEER.

1. The progress schedule will be acceptable to ENGINEER if it provides an orderly progression of the Work to completion within any specified Milestones and the Contract Times. Such acceptance will not impose on ENGINEER responsibility for the progress schedule, for sequencing, scheduling, or progress of the Work nor interfere with or relieve CONTRACTOR from CONTRACTOR's full responsibility therefor.

2. CONTRACTOR's schedule of Shop Drawing and Sample submittals will be acceptable to ENGINEER if it provides a workable arrangement for reviewing and processing the required submittals.

3. CONTRACTOR's schedule of values will be acceptable to ENGINEER as to form and substance if it provides a reasonable allocation of the Contract Price to component parts of the Work.

ARTICLE 3 - CONTRACT DOCUMENTS: INTENT, AMENDING, REUSE

3.01 *Intent*

A. The Contract Documents are complementary; what is called for by one is as binding as if called for by all.

B. It is the intent of the Contract Documents to describe a functionally complete Project (or part thereof) to be constructed in accordance with the Contract Documents. Any labor, documentation, services, materials, or equipment that may reasonably be inferred from the Contract Documents or from prevailing custom or trade usage as being required to produce the intended result will be provided whether or not specifically called for at no additional cost to OWNER.

C. Clarifications and interpretations of the Contract Documents shall be issued by ENGINEER as provided in Article 9.

3.02 *Reference Standards*

A. *Standards, Specifications, Codes, Laws, and Regulations*

1. Reference to standards, specifications, manuals, or codes of any technical society, organization, or association, or to Laws or Regulations, whether such reference be specific or by implication, shall mean the standard, specification, manual, code, or Laws or Regulations in effect at the time of opening of Bids (or on the Effective Date of the Agreement if there were no Bids), except as may be otherwise specifically stated in the Contract Documents.

2. No provision of any such standard, specification, manual or code, or any instruction of a Supplier shall be effective to change the duties or responsibilities of OWNER, CONTRACTOR, or ENGINEER, or any of their subcontractors, consultants, agents, or employees from those set forth in the Contract Documents, nor shall any such provision or instruction be effective to assign to OWNER, ENGINEER, or any of ENGINEER's Consultants, agents, or employees any duty or authority to supervise or direct the performance of the Work or any duty or authority to undertake responsibility inconsistent with the provisions of the Contract Documents.

3.03 Reporting and Resolving Discrepancies

A. Reporting Discrepancies

1. If, during the performance of the Work, CONTRACTOR discovers any conflict, error, ambiguity, or discrepancy within the Contract Documents or between the Contract Documents and any provision of any Law or Regulation applicable to the performance of the Work or of any standard, specification, manual or code, or of any instruction of any Supplier, CONTRACTOR shall report it to ENGINEER in writing at once. CONTRACTOR shall not proceed with the Work affected thereby (except in an emergency as required by paragraph 6.16.A) until an amendment or supplement to the Contract Documents has been issued by one of the methods indicated in paragraph 3.04; provided, however, that CONTRACTOR shall not be liable to OWNER or ENGINEER for failure to report any such conflict, error, ambiguity, or discrepancy unless CONTRACTOR knew or reasonably should have known thereof.

B. Resolving Discrepancies

1. Except as may be otherwise specifically stated in the Contract Documents, the provisions of the Contract Documents shall take precedence in resolving any conflict, error, ambiguity, or discrepancy between the provisions of the Contract Documents and:

a. the provisions of any standard, specification, manual, code, or instruction (whether or not specifically incorporated by reference in the Contract Documents); or

b. the provisions of any Laws or Regulations applicable to the performance of the Work (unless such an interpretation of the provisions of the Contract Documents would result in violation of such Law or Regulation).

3.04 Amending and Supplementing Contract Documents

A. The Contract Documents may be amended to provide for additions, deletions, and revisions in the Work or to modify the terms and conditions thereof in one or more of the following ways: (i) a Written Amendment; (ii) a Change Order; or (iii) a Work Change Directive.

B. The requirements of the Contract Documents may be supplemented, and minor variations and deviations in the Work may be authorized, by one or more of the following ways: ~~(i) a Field Order;~~ (ii) ENGINEER's approval of a Shop Drawing or Sample;

or (iii) ENGINEER's written interpretation or clarification.

3.05 Reuse of Documents

A. CONTRACTOR and any Subcontractor or Supplier or other individual or entity performing or furnishing any of the Work under a direct or indirect contract with OWNER: (i) shall not have or acquire any title to or ownership rights in any of the Drawings, Specifications, or other documents (or copies of any thereof) prepared by or bearing the seal of ENGINEER or ENGINEER's Consultant, including electronic media editions; and (ii) shall not reuse any of such Drawings, Specifications, other documents, or copies thereof on extensions of the Project or any other project without written consent of OWNER and ENGINEER and specific written verification or adaption by ENGINEER. This prohibition will survive final payment, completion, and acceptance of the Work, or termination or completion of the Contract. Nothing herein shall preclude CONTRACTOR from retaining copies of the Contract Documents for record purposes.

ARTICLE 4 - AVAILABILITY OF LANDS; SUBSURFACE AND PHYSICAL CONDITIONS; REFERENCE POINTS

4.01 Availability of Lands

A. OWNER shall furnish the Site. OWNER shall notify CONTRACTOR of any encumbrances or restrictions not of general application but specifically related to use of the Site with which CONTRACTOR must comply in performing the Work. OWNER will obtain in a timely manner and pay for easements for permanent structures or permanent changes in existing facilities. If CONTRACTOR and OWNER are unable to agree on entitlement to or on the amount or extent, if any, of any adjustment in the Contract Price or Contract Times, or both, as a result of any delay in OWNER's furnishing the Site, CONTRACTOR may make a Claim therefor as provided in paragraph 10.05.

B. Upon reasonable written request, OWNER shall furnish CONTRACTOR with a current statement of record legal title and legal description of the lands upon which the Work is to be performed and OWNER's interest therein as necessary for giving notice of or filing a mechanic's or construction lien against such lands in accordance with applicable Laws and Regulations.

C. CONTRACTOR shall provide for all additional lands and access thereto that may be required for temporary construction facilities or storage of materials and equipment.

4.02 Subsurface and Physical Conditions

A. *Reports and Drawings:* The Supplementary Conditions identify:

1. those reports of explorations and tests of subsurface conditions at or contiguous to the Site that ENGINEER has used in preparing the Contract Documents; and

2. those drawings of physical conditions in or relating to existing surface or subsurface structures at or contiguous to the Site (except Underground Facilities) that ENGINEER has used in preparing the Contract Documents.

B. *Limited Reliance by CONTRACTOR on Technical Data Authorized:* CONTRACTOR may rely upon the general accuracy of the "technical data" contained in such reports and drawings, but such reports and drawings are not Contract Documents. Such "technical data" is identified in the Supplementary Conditions. Except for such reliance on such "technical data," CONTRACTOR may not rely upon or make any Claim against OWNER, ENGINEER, or any of ENGINEER's Consultants with respect to:

1. the completeness of such reports and drawings for CONTRACTOR's purposes, including, but not limited to, any aspects of the means, methods, techniques, sequences, and procedures of construction to be employed by CONTRACTOR, and safety precautions and programs incident thereto; or

2. other data, interpretations, opinions, and information contained in such reports or shown or indicated in such drawings; or

3. any CONTRACTOR interpretation of or conclusion drawn from any "technical data" or any such other data, interpretations, opinions, or information.

4.03 *Differing Subsurface or Physical Conditions*

A. *Notice:* If CONTRACTOR believes that any subsurface or physical condition at or contiguous to the Site that is uncovered or revealed either:

1. is of such a nature as to establish that any "technical data" on which CONTRACTOR is entitled to rely as provided in paragraph 4.02 is materially inaccurate; or

2. is of such a nature as to require a change in the Contract Documents; or

3. differs materially from that shown or indicated in the Contract Documents; or

4. is of an unusual nature, and differs materially from conditions ordinarily

encountered and generally recognized as inherent in work of the character provided for in the Contract Documents;

then CONTRACTOR shall, promptly after becoming aware thereof and before further disturbing the subsurface or physical conditions or performing any Work in connection therewith (except in an emergency as required by paragraph 6.16.A), notify OWNER and ENGINEER in writing about such condition. CONTRACTOR shall not further disturb such condition or perform any Work in connection therewith (except as aforesaid) until receipt of written order to do so.

B. *ENGINEER's Review:* After receipt of written notice as required by paragraph 4.03.A, ENGINEER will promptly review the pertinent condition, determine the necessity of OWNER's obtaining additional exploration or tests with respect thereto, and advise OWNER in writing (with a copy to CONTRACTOR) of ENGINEER's findings and conclusions.

C. *Possible Price and Times Adjustments*

1. The Contract Price or the Contract Times, or both, will be equitably adjusted to the extent that the existence of such differing subsurface or physical condition causes an increase or decrease in CONTRACTOR's cost of, or time required for, performance of the Work; subject, however, to the following:

a. such condition must meet any one or more of the categories described in paragraph 4.03.A; and

b. with respect to Work that is paid for on a Unit Price Basis, any adjustment in Contract Price will be subject to the provisions of paragraphs 9.08 and 11.03.

2. CONTRACTOR shall not be entitled to any adjustment in the Contract Price or Contract Times if:

a. CONTRACTOR knew of the existence of such conditions at the time CONTRACTOR made a final commitment to OWNER in respect of Contract Price and Contract Times by the submission of a Bid or becoming bound under a negotiated contract; or

b. the existence of such condition could reasonably have been discovered or revealed as a result of any examination, investigation, exploration, test, or study of the Site and contiguous areas required by the Bidding Requirements or Contract Documents to be conducted by or for CONTRACTOR prior to CONTRACTOR's making such final commitment; or

c. CONTRACTOR failed to give the written notice within the time and as required by paragraph 4.03.A.

3. If OWNER and CONTRACTOR are unable to agree on entitlement to or on the amount or extent, if any, of any adjustment in the Contract Price or Contract Times, or both, a Claim may be made therefor as provided in paragraph 10.05. However, OWNER, ENGINEER, and ENGINEER's Consultants shall not be liable to CONTRACTOR for any claims, costs, losses, or damages (including but not limited to all fees and charges of engineers, architects, attorneys, and other professionals and all court or arbitration or other dispute resolution costs) sustained by CONTRACTOR on or in connection with any other project or anticipated project.

4.04 *Underground Facilities*

A. *Shown or Indicated:* The information and data shown or indicated in the Contract Documents with respect to existing Underground Facilities at or contiguous to the Site is based on information and data furnished to OWNER or ENGINEER by the owners of such Underground Facilities, including OWNER, or by others. Unless it is otherwise expressly provided in the Supplementary Conditions:

1. OWNER and ENGINEER shall not be responsible for the accuracy or completeness of any such information or data; and

2. the cost of all of the following will be included in the Contract Price, and CONTRACTOR shall have full responsibility for:

a. reviewing and checking all such information and data,

b. locating all Underground Facilities shown or indicated in the Contract Documents,

c. coordination of the Work with the owners of such Underground Facilities, including OWNER, during construction, and

d. the safety and protection of all such Underground Facilities and repairing any damage thereto resulting from the Work.

B. *Not Shown or Indicated*

1. If an Underground Facility is uncovered or revealed at or contiguous to the Site which was not shown or indicated, or not shown or indicated with reasonable accuracy in the Contract Documents, CONTRACTOR shall,

promptly after becoming aware thereof and before further disturbing conditions affected thereby or performing any Work in connection therewith (except in an emergency as required by paragraph 6.16.A), identify the owner of such Underground Facility and give written notice to that owner and to OWNER and ENGINEER. ENGINEER will promptly review the Underground Facility and determine the extent, if any, to which a change is required in the Contract Documents to reflect and document the consequences of the existence or location of the Underground Facility. During such time, CONTRACTOR shall be responsible for the safety and protection of such Underground Facility.

2. If ENGINEER concludes that a change in the Contract Documents is required, a Work Change Directive or a Change Order will be issued to reflect and document such consequences. An equitable adjustment shall be made in the Contract Price or Contract Times, or both, to the extent that they are attributable to the existence or location of any Underground Facility that was not shown or indicated or not shown or indicated with reasonable accuracy in the Contract Documents and that CONTRACTOR did not know of and could not reasonably have been expected to be aware of or to have anticipated. If OWNER and CONTRACTOR are unable to agree on entitlement to or on the amount or extent, if any, of any such adjustment in Contract Price or Contract Times, OWNER or CONTRACTOR may make a Claim therefor as provided in paragraph 10.05.

4.05 *Reference Points*

A. OWNER shall provide engineering surveys to establish reference points for construction which in ENGINEER's judgment are necessary to enable CONTRACTOR to proceed with the Work. CONTRACTOR shall be responsible for laying out the Work, shall protect and preserve the established reference points and property monuments, and shall make no changes or relocations without the prior written approval of OWNER. CONTRACTOR shall report to ENGINEER whenever any reference point or property monument is lost or destroyed or requires relocation because of necessary changes in grades or locations, and shall be responsible for the accurate replacement or relocation of such reference points or property monuments by professionally qualified personnel.

4.06 *Hazardous Environmental Condition at Site*

A. *Reports and Drawings:* Reference is made to the Supplementary Conditions for the identification of those reports and drawings relating to a Hazardous Environmental Condition identified at the Site, if any,

that have been utilized by the ENGINEER in the preparation of the Contract Documents.

B. *Limited Reliance by CONTRACTOR on Technical Data Authorized:* CONTRACTOR may rely upon the general accuracy of the "technical data" contained in such reports and drawings, but such reports and drawings are not Contract Documents. Such "technical data" is identified in the Supplementary Conditions. Except for such reliance on such "technical data," CONTRACTOR may not rely upon or make any Claim against OWNER, ENGINEER or any of ENGINEER's Consultants with respect to:

1. the completeness of such reports and drawings for CONTRACTOR's purposes, including, but not limited to, any aspects of the means, methods, techniques, sequences and procedures of construction to be employed by CONTRACTOR and safety precautions and programs incident thereto; or
2. other data, interpretations, opinions and information contained in such reports or shown or indicated in such drawings; or
3. any CONTRACTOR interpretation of or conclusion drawn from any "technical data" or any such other data, interpretations, opinions or information.

C. CONTRACTOR shall not be responsible for any Hazardous Environmental Condition uncovered or revealed at the Site which was not shown or indicated in Drawings or Specifications or identified in the Contract Documents to be within the scope of the Work. CONTRACTOR shall be responsible for a Hazardous Environmental Condition created with any materials brought to the Site by CONTRACTOR, Subcontractors, Suppliers, or anyone else for whom CONTRACTOR is responsible.

D. If CONTRACTOR encounters a Hazardous Environmental Condition or if CONTRACTOR or anyone for whom CONTRACTOR is responsible creates a Hazardous Environmental Condition, CONTRACTOR shall immediately: (i) secure or otherwise isolate such condition; (ii) stop all Work in connection with such condition and in any area affected thereby (except in an emergency as required by paragraph 6.16); and (iii) notify OWNER and ENGINEER (and promptly thereafter confirm such notice in writing). OWNER shall promptly consult with ENGINEER concerning the necessity for OWNER to retain a qualified expert to evaluate such condition or take corrective action, if any.

E. CONTRACTOR shall not be required to resume Work in connection with such condition or in any affected area until after OWNER has obtained any required permits related thereto and delivered to CONTRACTOR written notice: (i) specifying that such

condition and any affected area is or has been rendered safe for the resumption of Work; or (ii) specifying any special conditions under which such Work may be resumed safely. If OWNER and CONTRACTOR cannot agree as to entitlement to or on the amount or extent, if any, of any adjustment in Contract Price or Contract Times, or both, as a result of such Work stoppage or such special conditions under which Work is agreed to be resumed by CONTRACTOR, either party may make a Claim therefor as provided in paragraph 10.05.

F. If after receipt of such written notice CONTRACTOR does not agree to resume such Work based on a reasonable belief it is unsafe, or does not agree to resume such Work under such special conditions, then OWNER may order the portion of the Work that is in the area affected by such condition to be deleted from the Work. If OWNER and CONTRACTOR cannot agree as to entitlement to or on the amount or extent, if any, of an adjustment in Contract Price or Contract Times as a result of deleting such portion of the Work, then either party may make a Claim therefor as provided in paragraph 10.05. OWNER may have such deleted portion of the Work performed by OWNER's own forces or others in accordance with Article 7.

G. To the fullest extent permitted by Laws and Regulations, OWNER shall indemnify and hold harmless CONTRACTOR, Subcontractors, ENGINEER, ENGINEER's Consultants and the officers, directors, partners, employees, agents, other consultants, and subcontractors of each and any of them from and against all claims, costs, losses, and damages (including but not limited to all fees and charges of engineers, architects, attorneys, and other professionals and all court or arbitration or other dispute resolution costs) arising out of or relating to a Hazardous Environmental Condition, provided that such Hazardous Environmental Condition: (i) was not shown or indicated in the Drawings or Specifications or identified in the Contract Documents to be included within the scope of the Work, and (ii) was not created by CONTRACTOR or by anyone for whom CONTRACTOR is responsible. Nothing in this paragraph 4.06.E shall obligate OWNER to indemnify any individual or entity from and against the consequences of that individual's or entity's own negligence.

H. To the fullest extent permitted by Laws and Regulations, CONTRACTOR shall indemnify and hold harmless OWNER, ENGINEER, ENGINEER's Consultants, and the officers, directors, partners, employees, agents, other consultants, and subcontractors of each and any of them from and against all claims, costs, losses, and damages (including but not limited to all fees and charges of engineers, architects, attorneys, and other professionals and all court or arbitration or other dispute resolution costs) arising out of or relating to a Hazardous Environmental Condition created by

CONTRACTOR or by anyone for whom CONTRACTOR is responsible. Nothing in this paragraph 4.06.F shall obligate CONTRACTOR to indemnify any individual or entity from and against the consequences of that individual's or entity's own negligence.

I. The provisions of paragraphs 4.02, 4.03, and 4.04 are not intended to apply to a Hazardous Environmental Condition uncovered or revealed at the Site.

ARTICLE 5 - BONDS AND INSURANCE

5.01 *Performance, Payment, and Other Bonds*

~~A. CONTRACTOR shall furnish performance and payment Bonds, each in an amount at least equal to the Contract Price as security for the faithful performance and payment of all CONTRACTOR's obligations under the Contract Documents. These Bonds shall remain in effect at least until one year after the date when final payment becomes due, except as provided otherwise by Laws or Regulations or by the Contract Documents. CONTRACTOR shall also furnish such other Bonds as are required by the Contract Documents.~~

B. All Bonds shall be in the form prescribed by the Contract Documents except as provided otherwise by Laws or Regulations, and shall be executed by such sureties as are named in the current list of "Companies Holding Certificates of Authority as Acceptable Sureties on Federal Bonds and as Acceptable Reinsuring Companies" as published in Circular 570 (amended) by the Financial Management Service, Surety Bond Branch, U.S. Department of the Treasury. All Bonds signed by an agent must be accompanied by a certified copy of such agent's authority to act.

C. If the surety on any Bond furnished by CONTRACTOR is declared bankrupt or becomes insolvent or its right to do business is terminated in any state where any part of the Project is located or it ceases to meet the requirements of paragraph 5.01.B, CONTRACTOR shall within 20 days thereafter substitute another Bond and surety, both of which shall comply with the requirements of paragraphs 5.01.B and 5.02.

5.02 *Licensed Sureties and Insurers*

A. All Bonds and insurance required by the Contract Documents to be purchased and maintained by OWNER or CONTRACTOR shall be obtained from surety or insurance companies that are duly licensed or authorized in the jurisdiction in which the Project is located to issue Bonds or insurance policies for the limits and coverages so required. Such surety and insurance companies shall also meet such additional

requirements and qualifications as may be provided in the Supplementary Conditions.

5.03 *Certificates of Insurance*

~~A. CONTRACTOR shall deliver to OWNER, with copies to each additional insured identified in the Supplementary Conditions, certificates of insurance (and other evidence of insurance requested by OWNER or any other additional insured) which CONTRACTOR is required to purchase and maintain. OWNER shall deliver to CONTRACTOR, with copies to each additional insured identified in the Supplementary Conditions, certificates of insurance (and other evidence of insurance requested by CONTRACTOR or any other additional insured) which OWNER is required to purchase and maintain.~~

5.04 *CONTRACTOR's Liability Insurance*

A. CONTRACTOR shall purchase and maintain such liability and other insurance as is appropriate for the Work being performed and as will provide protection from claims set forth below which may arise out of or result from CONTRACTOR's performance of the Work and CONTRACTOR's other obligations under the Contract Documents, whether it is to be performed by CONTRACTOR, any Subcontractor or Supplier, or by anyone directly or indirectly employed by any of them to perform any of the Work, or by anyone for whose acts any of them may be liable:

1. claims under workers' compensation, disability benefits, and other similar employee benefit acts;
2. claims for damages because of bodily injury, occupational sickness or disease, or death of CONTRACTOR's employees;
3. claims for damages because of bodily injury, sickness or disease, or death of any person other than CONTRACTOR's employees;
4. claims for damages insured by reasonably available personal injury liability coverage which are sustained: (i) by any person as a result of an offense directly or indirectly related to the employment of such person by CONTRACTOR, or (ii) by any other person for any other reason;
5. claims for damages, other than to the Work itself, because of injury to or destruction of tangible property wherever located, including loss of use resulting therefrom; and
6. claims for damages because of bodily injury or death of any person or property damage arising out of the ownership, maintenance or use of any motor vehicle.

B. The policies of insurance so required by this paragraph 5.04 to be purchased and maintained shall:

1. with respect to insurance required by paragraphs 5.04.A.3 through 5.04.A.6 inclusive, include as additional insureds (subject to any customary exclusion in respect of professional liability) OWNER, ENGINEER, ENGINEER's Consultants, and any other individuals or entities identified in the Supplementary Conditions, all of whom shall be listed as additional insureds, and include coverage for the respective officers, directors, partners, employees, agents, and other consultants and subcontractors of each and any of all such additional insureds, and the insurance afforded to these additional insureds shall provide primary coverage for all claims covered thereby;

2. include at least the specific coverages and be written for not less than the limits of liability provided in the Supplementary Conditions or required by Laws or Regulations, whichever is greater;

3. include completed operations insurance;

4. include contractual liability insurance covering CONTRACTOR's indemnity obligations under paragraphs 6.07, 6.11, and 6.20;

5. contain a provision or endorsement that the coverage afforded will not be canceled, materially changed or renewal refused until at least thirty days prior written notice has been given to OWNER and CONTRACTOR and to each other additional insured identified in the Supplementary Conditions to whom a certificate of insurance has been issued (and the certificates of insurance furnished by the CONTRACTOR pursuant to paragraph 5.03 will so provide);

6. remain in effect at least until final payment and at all times thereafter when CONTRACTOR may be correcting, removing, or replacing defective Work in accordance with paragraph 13.07; and

7. with respect to completed operations insurance, and any insurance coverage written on a claims-made basis, remain in effect for at least two years after final payment (and CONTRACTOR shall furnish OWNER and each other additional insured identified in the Supplementary Conditions, to whom a certificate of insurance has been issued, evidence satisfactory to OWNER and any such additional

insured of continuation of such insurance at final payment and one year thereafter).

5.05 *OWNER's Liability Insurance*

~~— A. In addition to the insurance required to be provided by CONTRACTOR under paragraph 5.04, OWNER, at OWNER's option, may purchase and maintain at OWNER's expense OWNER's own liability insurance as will protect OWNER against claims which may arise from operations under the Contract Documents.~~

5.06 *Property Insurance*

~~A. Unless otherwise provided in the Supplementary Conditions, OWNER shall purchase and maintain property insurance upon the Work at the Site in the amount of the full replacement cost thereof (subject to such deductible amounts as may be provided in the Supplementary Conditions or required by Laws and Regulations). This insurance shall:~~

~~1. include the interests of OWNER, CONTRACTOR, Subcontractors, ENGINEER, ENGINEER's Consultants, and any other individuals or entities identified in the Supplementary Conditions, and the officers, directors, partners, employees, agents, and other consultants and subcontractors of each and any of them, each of whom is deemed to have an insurable interest and shall be listed as an additional insured;~~

~~2. be written on a Builder's Risk "all risk" or open peril or special causes of loss policy form that shall at least include insurance for physical loss or damage to the Work, temporary buildings, false work, and materials and equipment in transit, and shall insure against at least the following perils or causes of loss: fire, lightning, extended coverage, theft, vandalism and malicious mischief, earthquake, collapse, debris removal, demolition occasioned by enforcement of Laws and Regulations, water damage, and such other perils or causes of loss as may be specifically required by the Supplementary Conditions;~~

~~3. include expenses incurred in the repair or replacement of any insured property (including but not limited to fees and charges of engineers and architects);~~

~~4. cover materials and equipment stored at the Site or at another location that was agreed to in writing by OWNER prior to being incorporated in the Work, provided that such materials and equipment have been included in an Application for Payment recommended by ENGINEER;~~

~~5. allow for partial utilization of the Work by OWNER;~~

~~6. include testing and startup; and~~

~~7. be maintained in effect until final payment is made unless otherwise agreed to in writing by OWNER, CONTRACTOR, and ENGINEER with 30 days written notice to each other additional insured to whom a certificate of insurance has been issued.~~

~~B. OWNER shall purchase and maintain such boiler and machinery insurance or additional property insurance as may be required by the Supplementary Conditions or Laws and Regulations which will include the interests of OWNER, CONTRACTOR, Subcontractors, ENGINEER, ENGINEER's Consultants, and any other individuals or entities identified in the Supplementary Conditions, each of whom is deemed to have an insurable interest and shall be listed as an insured or additional insured.~~

~~C. All the policies of insurance (and the certificates or other evidence thereof) required to be purchased and maintained in accordance with paragraph 5.06 will contain a provision or endorsement that the coverage afforded will not be canceled or materially changed or renewal refused until at least 30 days prior written notice has been given to OWNER and CONTRACTOR and to each other additional insured to whom a certificate of insurance has been issued and will contain waiver provisions in accordance with paragraph 5.07.~~

D. OWNER shall not be responsible for purchasing and maintaining any property insurance specified in this paragraph 5.06 to protect the interests of CONTRACTOR, Subcontractors, or others in the Work to the extent of any deductible amounts that are identified in the Supplementary Conditions. The risk of loss within such identified deductible amount will be borne by CONTRACTOR, Subcontractors, or others suffering any such loss, and if any of them wishes property insurance coverage within the limits of such amounts, each may purchase and maintain it at the purchaser's own expense.

~~E. If CONTRACTOR requests in writing that other special insurance be included in the property insurance policies provided under paragraph 5.06, OWNER shall, if possible, include such insurance, and the cost thereof will be charged to CONTRACTOR by appropriate Change Order or Written Amendment. Prior to commencement of the Work at the Site, OWNER shall in writing advise CONTRACTOR whether or not such other insurance has been procured by OWNER.~~

5.07 Waiver of Rights

~~A. OWNER and CONTRACTOR intend that all policies purchased in accordance with paragraph 5.06 will protect OWNER, CONTRACTOR, Subcontractors, ENGINEER, ENGINEER's Consultants, and all other individuals or entities identified in the Supplementary Conditions to be listed as insureds or additional insureds (and the officers, directors, partners, employees, agents, and other consultants and subcontractors of each and any of them) in such policies and will provide primary coverage for all losses and damages caused by the perils or causes of loss covered thereby. All such policies shall contain provisions to the effect that in the event of payment of any loss or damage the insurers will have no rights of recovery against any of the insureds or additional insureds thereunder. OWNER and CONTRACTOR waive all rights against each other and their respective officers, directors, partners, employees, agents, and other consultants and subcontractors of each and any of them for all losses and damages caused by, arising out of or resulting from any of the perils or causes of loss covered by such policies and any other property insurance applicable to the Work; and, in addition, waive all such rights against Subcontractors, ENGINEER, ENGINEER's Consultants, and all other individuals or entities identified in the Supplementary Conditions to be listed as insureds or additional insureds (and the officers, directors, partners, employees, agents, and other consultants and subcontractors of each and any of them) under such policies for losses and damages so caused. None of the above waivers shall extend to the rights that any party making such waiver may have to the proceeds of insurance held by OWNER as trustee or otherwise payable under any policy so issued.~~

~~B. OWNER waives all rights against CONTRACTOR, Subcontractors, ENGINEER, ENGINEER's Consultants, and the officers, directors, partners, employees, agents, and other consultants and subcontractors of each and any of them for:~~

~~1. loss due to business interruption, loss of use, or other consequential loss extending beyond direct physical loss or damage to OWNER's property or the Work caused by, arising out of, or resulting from fire or other peril whether or not insured by OWNER; and~~

~~2. loss or damage to the completed Project or part thereof caused by, arising out of, or resulting from fire or other insured peril or cause of loss covered by any property insurance maintained on the completed Project or part thereof by OWNER during partial utilization pursuant to paragraph 14.05, after Substantial Completion pursuant to paragraph 14.04, or after final payment pursuant to paragraph 14.07.~~

~~—C. Any insurance policy maintained by OWNER covering any loss, damage or consequential loss referred to in paragraph 5.07.B shall contain provisions to the effect that in the event of payment of any such loss, damage, or consequential loss, the insurers will have no rights of recovery against CONTRACTOR, Subcontractors, ENGINEER, or ENGINEER's Consultants and the officers, directors, partners, employees, agents, and other consultants and subcontractors of each and any of them.~~

5.08 *Receipt and Application of Insurance Proceeds*

~~—A. Any insured loss under the policies of insurance required by paragraph 5.06 will be adjusted with OWNER and made payable to OWNER as fiduciary for the insureds, as their interests may appear, subject to the requirements of any applicable mortgage clause and of paragraph 5.08.B. OWNER shall deposit in a separate account any money so received and shall distribute it in accordance with such agreement as the parties in interest may reach. If no other special agreement is reached, the damaged Work shall be repaired or replaced, the moneys so received applied on account thereof, and the Work and the cost thereof covered by an appropriate Change Order or Written Amendment.~~

~~—B. OWNER as fiduciary shall have power to adjust and settle any loss with the insurers unless one of the parties in interest shall object in writing within 15 days after the occurrence of loss to OWNER's exercise of this power. If such objection be made, OWNER as fiduciary shall make settlement with the insurers in accordance with such agreement as the parties in interest may reach. If no such agreement among the parties in interest is reached, OWNER as fiduciary shall adjust and settle the loss with the insurers and, if required in writing by any party in interest, OWNER as fiduciary shall give bond for the proper performance of such duties.~~

5.09 *Acceptance of Bonds and Insurance; Option to Replace*

~~A. If either OWNER or CONTRACTOR has any objection to the coverage afforded by or other provisions of the Bonds or insurance required to be purchased and maintained by the other party in accordance with Article 5 on the basis of non-conformance with the Contract Documents, the objecting party shall so notify the other party in writing within 10 days after receipt of the certificates (or other evidence requested) required by paragraph 2.05.C. OWNER and CONTRACTOR shall each provide to the other such additional information in respect of insurance provided as the other may reasonably request. If either party does not purchase or maintain all of the Bonds and insurance required of such party by the Contract Documents, such party shall notify the other party in writing of such failure to purchase prior to the start of~~

~~the Work, or of such failure to maintain prior to any change in the required coverage. Without prejudice to any other right or remedy, the other party may elect to obtain equivalent Bonds or insurance to protect such other party's interests at the expense of the party who was required to provide such coverage, and a Change Order shall be issued to adjust the Contract Price accordingly.~~

5.10 *Partial Utilization, Acknowledgment of Property Insurer*

A. If OWNER finds it necessary to occupy or use a portion or portions of the Work prior to Substantial Completion of all the Work as provided in paragraph 14.05, no such use or occupancy shall commence before the insurers providing the property insurance pursuant to paragraph 5.06 have acknowledged notice thereof and in writing effected any changes in coverage necessitated thereby. The insurers providing the property insurance shall consent by endorsement on the policy or policies, but the property insurance shall not be canceled or permitted to lapse on account of any such partial use or occupancy.

ARTICLE 6 - CONTRACTOR'S RESPONSIBILITIES

6.01 *Supervision and Superintendence*

A. CONTRACTOR shall supervise, inspect, and direct the Work competently and efficiently, devoting such attention thereto and applying such skills and expertise as may be necessary to perform the Work in accordance with the Contract Documents. CONTRACTOR shall be solely responsible for the means, methods, techniques, sequences, and procedures of construction, but CONTRACTOR shall not be responsible for the negligence of OWNER or ENGINEER in the design or specification of a specific means, method, technique, sequence, or procedure of construction which is shown or indicated in and expressly required by the Contract Documents. CONTRACTOR shall be responsible to see that the completed Work complies accurately with the Contract Documents.

B. At all times during the progress of the Work, CONTRACTOR shall assign a competent resident superintendent thereto who shall not be replaced without written notice to OWNER and ENGINEER except under extraordinary circumstances. The superintendent will be CONTRACTOR's representative at the Site and shall have authority to act on behalf of CONTRACTOR. All communications given to or received from the superintendent shall be binding on CONTRACTOR.

6.02 Labor; Working Hours

A. CONTRACTOR shall provide competent, suitably qualified personnel to survey, lay out, and construct the Work as required by the Contract Documents. CONTRACTOR shall at all times maintain good discipline and order at the Site.

B. Except as otherwise required for the safety or protection of persons or the Work or property at the Site or adjacent thereto, and except as otherwise stated in the Contract Documents, all Work at the Site shall be performed during regular working hours, and CONTRACTOR will not permit overtime work or the performance of Work on Saturday, Sunday, or any legal holiday without OWNER's written consent (which will not be unreasonably withheld) given after prior written notice to ENGINEER.

6.03 Services, Materials, and Equipment

A. Unless otherwise specified in the General Requirements, CONTRACTOR shall provide and assume full responsibility for all services, materials, equipment, labor, transportation, construction equipment and machinery, tools, appliances, fuel, power, light, heat, telephone, water, sanitary facilities, temporary facilities, and all other facilities and incidentals necessary for the performance, testing, start-up, and completion of the Work.

B. All materials and equipment incorporated into the Work shall be as specified or, if not specified, shall be of good quality and new, except as otherwise provided in the Contract Documents. All warranties and guarantees specifically called for by the Specifications shall expressly run to the benefit of OWNER. If required by ENGINEER, CONTRACTOR shall furnish satisfactory evidence (including reports of required tests) as to the source, kind, and quality of materials and equipment. All materials and equipment shall be stored, applied, installed, connected, erected, protected, used, cleaned, and conditioned in accordance with instructions of the applicable Supplier, except as otherwise may be provided in the Contract Documents.

6.04 Progress Schedule

A. CONTRACTOR shall adhere to the progress schedule established in accordance with paragraph 2.07 as it may be adjusted from time to time as provided below.

1. CONTRACTOR shall submit to ENGINEER for acceptance (to the extent indicated in paragraph 2.07) proposed adjustments in the progress schedule that will not result in changing the Contract Times (or Milestones). Such adjustments will conform generally to the

progress schedule then in effect and additionally will comply with any provisions of the General Requirements applicable thereto.

2. Proposed adjustments in the progress schedule that will change the Contract Times (or Milestones) shall be submitted in accordance with the requirements of Article 12. Such adjustments may only be made by a Change Order or Written Amendment in accordance with Article 12.

6.05 Substitutes and "Or-Equals"

A. Whenever an item of material or equipment is specified or described in the Contract Documents by using the name of a proprietary item or the name of a particular Supplier, the specification or description is intended to establish the type, function, appearance, and quality required. Unless the specification or description contains or is followed by words reading that no like, equivalent, or "or-equal" item or no substitution is permitted, other items of material or equipment or material or equipment of other Suppliers may be submitted to ENGINEER for review under the circumstances described below.

1. "Or-Equal" Items: If in ENGINEER's sole discretion an item of material or equipment proposed by CONTRACTOR is functionally equal to that named and sufficiently similar so that no change in related Work will be required, it may be considered by ENGINEER as an "or-equal" item, in which case review and approval of the proposed item may, in ENGINEER's sole discretion, be accomplished without compliance with some or all of the requirements for approval of proposed substitute items. For the purposes of this paragraph 6.05.A.1, a proposed item of material or equipment will be considered functionally equal to an item so named if:

a. in the exercise of reasonable judgment ENGINEER determines that: (i) it is at least equal in quality, durability, appearance, strength, and design characteristics; (ii) it will reliably perform at least equally well the function imposed by the design concept of the completed Project as a functioning whole, and;

b. CONTRACTOR certifies that: (i) there is no increase in cost to the OWNER; and (ii) it will conform substantially, even with deviations, to the detailed requirements of the item named in the Contract Documents.

2. Substitute Items

a. If in ENGINEER's sole discretion an item of material or equipment proposed by

CONTRACTOR does not qualify as an "or-equal" item under paragraph 6.05.A.1, it will be considered a proposed substitute item.

b. CONTRACTOR shall submit sufficient information as provided below to allow ENGINEER to determine that the item of material or equipment proposed is essentially equivalent to that named and an acceptable substitute therefor. Requests for review of proposed substitute items of material or equipment will not be accepted by ENGINEER from anyone other than CONTRACTOR.

c. The procedure for review by ENGINEER will be as set forth in paragraph 6.05.A.2.d, as supplemented in the General Requirements and as ENGINEER may decide is appropriate under the circumstances.

d. CONTRACTOR shall first make written application to ENGINEER for review of a proposed substitute item of material or equipment that CONTRACTOR seeks to furnish or use. The application shall certify that the proposed substitute item will perform adequately the functions and achieve the results called for by the general design, be similar in substance to that specified, and be suited to the same use as that specified. The application will state the extent, if any, to which the use of the proposed substitute item will prejudice CONTRACTOR's achievement of Substantial Completion on time, whether or not use of the proposed substitute item in the Work will require a change in any of the Contract Documents (or in the provisions of any other direct contract with OWNER for work on the Project) to adapt the design to the proposed substitute item and whether or not incorporation or use of the proposed substitute item in connection with the Work is subject to payment of any license fee or royalty. All variations of the proposed substitute item from that specified will be identified in the application, and available engineering, sales, maintenance, repair, and replacement services will be indicated. The application will also contain an itemized estimate of all costs or credits that will result directly or indirectly from use of such substitute item, including costs of redesign and claims of other contractors affected by any resulting change, all of which will be considered by ENGINEER in evaluating the proposed substitute item. ENGINEER may require CONTRACTOR to furnish additional data about the proposed substitute item.

B. *Substitute Construction Methods or Procedures:* If a specific means, method, technique, sequence, or procedure of construction is shown or indicated in and expressly required by the Contract Documents, CONTRACTOR may furnish or utilize a substitute means, method, technique, sequence, or procedure of construction approved by ENGINEER. CONTRACTOR shall submit sufficient information to allow ENGINEER, in ENGINEER's sole discretion, to determine that the substitute proposed is equivalent to that expressly called for by the Contract Documents. The procedure for review by ENGINEER will be similar to that provided in subparagraph 6.05.A.2.

C. *Engineer's Evaluation:* ENGINEER will be allowed a reasonable time within which to evaluate each proposal or submittal made pursuant to paragraphs 6.05.A and 6.05.B. ENGINEER will be the sole judge of acceptability. No "or-equal" or substitute will be ordered, installed or utilized until ENGINEER's review is complete, which will be evidenced by either a Change Order for a substitute or an approved Shop Drawing for an "or equal." ENGINEER will advise CONTRACTOR in writing of any negative determination.

D. *Special Guarantee:* OWNER may require CONTRACTOR to furnish at CONTRACTOR's expense a special performance guarantee or other surety with respect to any substitute.

E. *ENGINEER's Cost Reimbursement:* ENGINEER will record time required by ENGINEER and ENGINEER's Consultants in evaluating substitute proposed or submitted by CONTRACTOR pursuant to paragraphs 6.05.A.2 and 6.05.B and in making changes in the Contract Documents (or in the provisions of any other direct contract with OWNER for work on the Project) occasioned thereby. Whether or not ENGINEER approves a substitute item so proposed or submitted by CONTRACTOR, CONTRACTOR shall reimburse OWNER for the charges of ENGINEER and ENGINEER's Consultants for evaluating each such proposed substitute.

F. *CONTRACTOR's Expense:* CONTRACTOR shall provide all data in support of any proposed substitute or "or-equal" at CONTRACTOR's expense.

6.06 Concerning Subcontractors, Suppliers, and Others

A. CONTRACTOR shall not employ any Subcontractor, Supplier, or other individual or entity (including those acceptable to OWNER as indicated in paragraph 6.06.B), whether initially or as a replacement, against whom OWNER may have reasonable objection. CONTRACTOR shall not be required to employ any Subcontractor, Supplier, or other individual or entity to furnish or perform any of the Work against whom CONTRACTOR has reasonable objection.

B. If the Supplementary Conditions require the identity of certain Subcontractors, Suppliers, or other individuals or entities to be submitted to OWNER in advance for acceptance by OWNER by a specified date prior to the Effective Date of the Agreement, and if CONTRACTOR has submitted a list thereof in accordance with the Supplementary Conditions, OWNER's acceptance (either in writing or by failing to make written objection thereto by the date indicated for acceptance or objection in the Bidding Documents or the Contract Documents) of any such Subcontractor, Supplier, or other individual or entity so identified may be revoked on the basis of reasonable objection after due investigation. CONTRACTOR shall submit an acceptable replacement for the rejected Subcontractor, Supplier, or other individual or entity, and the Contract Price will be adjusted by the difference in the cost occasioned by such replacement, and an appropriate Change Order will be issued or Written Amendment signed. No acceptance by OWNER of any such Subcontractor, Supplier, or other individual or entity, whether initially or as a replacement, shall constitute a waiver of any right of OWNER or ENGINEER to reject defective Work.

C. CONTRACTOR shall be fully responsible to OWNER and ENGINEER for all acts and omissions of the Subcontractors, Suppliers, and other individuals or entities performing or furnishing any of the Work just as CONTRACTOR is responsible for CONTRACTOR's own acts and omissions. Nothing in the Contract Documents shall create for the benefit of any such Subcontractor, Supplier, or other individual or entity any contractual relationship between OWNER or ENGINEER and any such Subcontractor, Supplier or other individual or entity, nor shall it create any obligation on the part of OWNER or ENGINEER to pay or to see to the payment of any moneys due any such Subcontractor, Supplier, or other individual or entity except as may otherwise be required by Laws and Regulations.

D. CONTRACTOR shall be solely responsible for scheduling and coordinating the Work of Subcontractors, Suppliers, and other individuals or entities performing or furnishing any of the Work under a direct or indirect contract with CONTRACTOR.

E. CONTRACTOR shall require all Subcontractors, Suppliers, and such other individuals or entities performing or furnishing any of the Work to communicate with ENGINEER through CONTRACTOR.

F. The divisions and sections of the Specifications and the identifications of any Drawings shall not control CONTRACTOR in dividing the Work among Subcontractors or Suppliers or delineating the Work to be performed by any specific trade.

G. All Work performed for CONTRACTOR by a Subcontractor or Supplier will be pursuant to an appropriate agreement between CONTRACTOR and the Subcontractor or Supplier which specifically binds the Subcontractor or Supplier to the applicable terms and conditions of the Contract Documents for the benefit of OWNER and ENGINEER. Whenever any such agreement is with a Subcontractor or Supplier who is listed as an additional insured on the property insurance provided in paragraph 5.06, the agreement between the CONTRACTOR and the Subcontractor or Supplier will contain provisions whereby the Subcontractor or Supplier waives all rights against OWNER, CONTRACTOR, ENGINEER, ENGINEER's Consultants, and all other individuals or entities identified in the Supplementary Conditions to be listed as insureds or additional insureds (and the officers, directors, partners, employees, agents, and other consultants and subcontractors of each and any of them) for all losses and damages caused by, arising out of, relating to, or resulting from any of the perils or causes of loss covered by such policies and any other property insurance applicable to the Work. If the insurers on any such policies require separate waiver forms to be signed by any Subcontractor or Supplier, CONTRACTOR will obtain the same.

6.07 *Patent Fees and Royalties*

A. CONTRACTOR shall pay all license fees and royalties and assume all costs incident to the use in the performance of the Work or the incorporation in the Work of any invention, design, process, product, or device which is the subject of patent rights or copyrights held by others. If a particular invention, design, process, product, or device is specified in the Contract Documents for use in the performance of the Work and if to the actual knowledge of OWNER or ENGINEER its use is subject to patent rights or copyrights calling for the payment of any license fee or royalty to others, the existence of such rights shall be disclosed by OWNER in the Contract Documents. To the fullest extent permitted by Laws and Regulations, CONTRACTOR shall indemnify and hold harmless OWNER, ENGINEER, ENGINEER's Consultants, and the officers, directors, partners, employees or agents, and other consultants of each and any of them from and against all claims, costs, losses, and damages (including but not limited to all fees and charges of engineers, architects, attorneys, and other professionals and all court or arbitration or other dispute resolution costs) arising out of or relating to any infringement of patent rights or copyrights incident to the use in the performance of the Work or resulting from the incorporation in the Work of any invention, design, process, product, or device not specified in the Contract Documents.

6.08 *Permits*

A. Unless otherwise provided in the Supplementary Conditions, CONTRACTOR shall obtain and

pay for all construction permits and licenses. OWNER shall assist CONTRACTOR, when necessary, in obtaining such permits and licenses. CONTRACTOR shall pay all governmental charges and inspection fees necessary for the prosecution of the Work which are applicable at the time of opening of Bids, or, if there are no Bids, on the Effective Date of the Agreement. CONTRACTOR shall pay all charges of utility owners for connections to the Work, and OWNER shall pay all charges of such utility owners for capital costs related thereto, such as plant investment fees.

6.09 *Laws and Regulations*

A. CONTRACTOR shall give all notices and comply with all Laws and Regulations applicable to the performance of the Work. Except where otherwise expressly required by applicable Laws and Regulations, neither OWNER nor ENGINEER shall be responsible for monitoring CONTRACTOR's compliance with any Laws or Regulations.

B. If CONTRACTOR performs any Work knowing or having reason to know that it is contrary to Laws or Regulations, CONTRACTOR shall bear all claims, costs, losses, and damages (including but not limited to all fees and charges of engineers, architects, attorneys, and other professionals and all court or arbitration or other dispute resolution costs) arising out of or relating to such Work; however, it shall not be CONTRACTOR's primary responsibility to make certain that the Specifications and Drawings are in accordance with Laws and Regulations, but this shall not relieve CONTRACTOR of CONTRACTOR's obligations under paragraph 3.03.

C. Changes in Laws or Regulations not known at the time of opening of Bids (or, on the Effective Date of the Agreement if there were no Bids) having an effect on the cost or time of performance of the Work may be the subject of an adjustment in Contract Price or Contract Times. If OWNER and CONTRACTOR are unable to agree on entitlement to or on the amount or extent, if any, of any such adjustment, a Claim may be made therefor as provided in paragraph 10.05.

6.10 *Taxes*

- A. CONTRACTOR shall pay all sales, consumer, use, and other similar taxes required to be paid by CONTRACTOR in accordance with the Laws and Regulations of the place of the Project which are applicable during the performance of the Work.
- B. OWNER qualifies for state and local sales tax exemption in the purchase of all material and equipment.

6.11 *Use of Site and Other Areas*

A. *Limitation on Use of Site and Other Areas*

1. CONTRACTOR shall confine construction equipment, the storage of materials and equipment, and the operations of workers to the Site and other areas permitted by Laws and Regulations, and shall not unreasonably encumber the Site and other areas with construction equipment or other materials or equipment. CONTRACTOR shall assume full responsibility for any damage to any such land or area, or to the owner or occupant thereof, or of any adjacent land or areas resulting from the performance of the Work.

2. Should any claim be made by any such owner or occupant because of the performance of the Work, CONTRACTOR shall promptly settle with such other party by negotiation or otherwise resolve the claim by arbitration or other dispute resolution proceeding or at law.

3. To the fullest extent permitted by Laws and Regulations, CONTRACTOR shall indemnify and hold harmless OWNER, ENGINEER, ENGINEER's Consultant, and the officers, directors, partners, employees, agents, and other consultants of each and any of them from and against all claims, costs, losses, and damages (including but not limited to all fees and charges of engineers, architects, attorneys, and other professionals and all court or arbitration or other dispute resolution costs) arising out of or relating to any claim or action, legal or equitable, brought by any such owner or occupant against OWNER, ENGINEER, or any other party indemnified hereunder to the extent caused by or based upon CONTRACTOR's performance of the Work.

B. *Removal of Debris During Performance of the Work:* During the progress of the Work CONTRACTOR shall keep the Site and other areas free from accumulations of waste materials, rubbish, and other debris. Removal and disposal of such waste materials, rubbish, and other debris shall conform to applicable Laws and Regulations.

C. *Cleaning:* Prior to Substantial Completion of the Work CONTRACTOR shall clean the Site and make it ready for utilization by OWNER. At the completion of the Work CONTRACTOR shall remove from the Site all tools, appliances, construction equipment and machinery, and surplus materials and shall restore to original condition all property not designated for alteration by the Contract Documents.

D. *Loading Structures:* CONTRACTOR shall not load nor permit any part of any structure to be loaded

in any manner that will endanger the structure, nor shall CONTRACTOR subject any part of the Work or adjacent property to stresses or pressures that will endanger it.

6.12 Record Documents

A. CONTRACTOR shall maintain in a safe place at the Site one record copy of all Drawings, Specifications, Addenda, Written Amendments, Change Orders, Work Change Directives, Field Orders, and written interpretations and clarifications in good order and annotated to show changes made during construction. These record documents together with all approved Samples and a counterpart of all approved Shop Drawings will be available to ENGINEER for reference. Upon completion of the Work, these record documents, Samples, and Shop Drawings will be delivered to ENGINEER for OWNER.

6.13 Safety and Protection

A. CONTRACTOR shall be solely responsible for initiating, maintaining and supervising all safety precautions and programs in connection with the Work. CONTRACTOR shall take all necessary precautions for the safety of, and shall provide the necessary protection to prevent damage, injury or loss to:

1. all persons on the Site or who may be affected by the Work;
2. all the Work and materials and equipment to be incorporated therein, whether in storage on or off the Site; and
3. other property at the Site or adjacent thereto, including trees, shrubs, lawns, walks, pavements, roadways, structures, utilities, and Underground Facilities not designated for removal, relocation, or replacement in the course of construction.

B. CONTRACTOR shall comply with all applicable Laws and Regulations relating to the safety of persons or property, or to the protection of persons or property from damage, injury, or loss; and shall erect and maintain all necessary safeguards for such safety and protection. CONTRACTOR shall notify owners of adjacent property and of Underground Facilities and other utility owners when prosecution of the Work may affect them, and shall cooperate with them in the protection, removal, relocation, and replacement of their property. All damage, injury, or loss to any property referred to in paragraph 6.13.A.2 or 6.13.A.3 caused, directly or indirectly, in whole or in part, by CONTRACTOR, any Subcontractor, Supplier, or any other individual or entity directly or indirectly employed by any of them to perform any of the Work, or anyone for whose acts any of them may be liable, shall be remedied by CONTRACTOR (except damage or loss

attributable to the fault of Drawings or Specifications or to the acts or omissions of OWNER or ENGINEER or ENGINEER's Consultant, or anyone employed by any of them, or anyone for whose acts any of them may be liable, and not attributable, directly or indirectly, in whole or in part, to the fault or negligence of CONTRACTOR or any Subcontractor, Supplier, or other individual or entity directly or indirectly employed by any of them). CONTRACTOR's duties and responsibilities for safety and for protection of the Work shall continue until such time as all the Work is completed and ENGINEER has issued a notice to OWNER and CONTRACTOR in accordance with paragraph 14.07.B that the Work is acceptable (except as otherwise expressly provided in connection with Substantial Completion).

6.14 Safety Representative

A. CONTRACTOR shall designate a qualified and experienced safety representative at the Site whose duties and responsibilities shall be the prevention of accidents and the maintaining and supervising of safety precautions and programs.

6.15 Hazard Communication Programs

A. CONTRACTOR shall be responsible for coordinating any exchange of material safety data sheets or other hazard communication information required to be made available to or exchanged between or among employers at the Site in accordance with Laws or Regulations.

6.16 Emergencies

A. In emergencies affecting the safety or protection of persons or the Work or property at the Site or adjacent thereto, CONTRACTOR is obligated to act to prevent threatened damage, injury, or loss. CONTRACTOR shall give ENGINEER prompt written notice if CONTRACTOR believes that any significant changes in the Work or variations from the Contract Documents have been caused thereby or are required as a result thereof. If ENGINEER determines that a change in the Contract Documents is required because of the action taken by CONTRACTOR in response to such an emergency, a Work Change Directive or Change Order will be issued.

6.17 Shop Drawings and Samples

A. CONTRACTOR shall submit Shop Drawings to ENGINEER for review and approval in accordance with the acceptable schedule of Shop Drawings and Sample submittals. All submittals will be identified as ENGINEER may require and in the number of copies specified in the General Requirements. The data shown on the Shop Drawings will be complete with respect to quantities, dimensions, specified performance and design criteria, materials, and similar data to show ENGINEER the services, materials, and

equipment CONTRACTOR proposes to provide and to enable ENGINEER to review the information for the limited purposes required by paragraph 6.17.E.

B. CONTRACTOR shall also submit Samples to ENGINEER for review and approval in accordance with the acceptable schedule of Shop Drawings and Sample submittals. Each Sample will be identified clearly as to material, Supplier, pertinent data such as catalog numbers, and the use for which intended and otherwise as ENGINEER may require to enable ENGINEER to review the submittal for the limited purposes required by paragraph 6.17.E. The numbers of each Sample to be submitted will be as specified in the Specifications.

C. Where a Shop Drawing or Sample is required by the Contract Documents or the schedule of Shop Drawings and Sample submittals acceptable to ENGINEER as required by paragraph 2.07, any related Work performed prior to ENGINEER's review and approval of the pertinent submittal will be at the sole expense and responsibility of CONTRACTOR.

D. *Submittal Procedures*

1. Before submitting each Shop Drawing or Sample, CONTRACTOR shall have determined and verified:

a. all field measurements, quantities, dimensions, specified performance criteria, installation requirements, materials, catalog numbers, and similar information with respect thereto;

b. all materials with respect to intended use, fabrication, shipping, handling, storage, assembly, and installation pertaining to the performance of the Work;

c. all information relative to means, methods, techniques, sequences, and procedures of construction and safety precautions and programs incident thereto; and

d. CONTRACTOR shall also have reviewed and coordinated each Shop Drawing or Sample with other Shop Drawings and Samples and with the requirements of the Work and the Contract Documents.

2. Each submittal shall bear a stamp or specific written indication that CONTRACTOR has satisfied CONTRACTOR's obligations under the Contract Documents with respect to CONTRACTOR's review and approval of that submittal.

3. At the time of each submittal, CONTRACTOR shall give ENGINEER specific written notice of such variations, if any, that the Shop Drawing or Sample submitted may have from the requirements of the Contract Documents, such notice to be in a written communication separate from the submittal; and, in addition, shall cause a specific notation to be made on each Shop Drawing and Sample submitted to ENGINEER for review and approval of each such variation.

E. *ENGINEER's Review*

1. ENGINEER will timely review and approve Shop Drawings and Samples in accordance with the schedule of Shop Drawings and Sample submittals acceptable to ENGINEER. ENGINEER's review and approval will be only to determine if the items covered by the submittals will, after installation or incorporation in the Work, conform to the information given in the Contract Documents and be compatible with the design concept of the completed Project as a functioning whole as indicated by the Contract Documents.

2. ENGINEER's review and approval will not extend to means, methods, techniques, sequences, or procedures of construction (except where a particular means, method, technique, sequence, or procedure of construction is specifically and expressly called for by the Contract Documents) or to safety precautions or programs incident thereto. The review and approval of a separate item as such will not indicate approval of the assembly in which the item functions.

3. ENGINEER's review and approval of Shop Drawings or Samples shall not relieve CONTRACTOR from responsibility for any variation from the requirements of the Contract Documents unless CONTRACTOR has in writing called ENGINEER's attention to each such variation at the time of each submittal as required by paragraph 6.17.D.3 and ENGINEER has given written approval of each such variation by specific written notation thereof incorporated in or accompanying the Shop Drawing or Sample approval; nor will any approval by ENGINEER relieve CONTRACTOR from responsibility for complying with the requirements of paragraph 6.17.D.1.

F. *Resubmittal Procedures*

1. CONTRACTOR shall make corrections required by ENGINEER and shall return the required number of corrected copies of Shop Drawings and submit as required new Samples for review and approval. CONTRACTOR shall

direct specific attention in writing to revisions other than the corrections called for by ENGINEER on previous submittals.

6.18 *Continuing the Work*

A. CONTRACTOR shall carry on the Work and adhere to the progress schedule during all disputes or disagreements with OWNER. No Work shall be delayed or postponed pending resolution of any disputes or disagreements, except as permitted by paragraph 15.04 or as OWNER and CONTRACTOR may otherwise agree in writing.

6.19 *CONTRACTOR's General Warranty and Guarantee*

A. CONTRACTOR warrants and guarantees to OWNER, ENGINEER, and ENGINEER's Consultants that all Work will be in accordance with the Contract Documents and will not be defective. CONTRACTOR's warranty and guarantee hereunder excludes defects or damage caused by:

1. abuse, modification, or improper maintenance or operation by persons other than CONTRACTOR, Subcontractors, Suppliers, or any other individual or entity for whom CONTRACTOR is responsible; or
2. normal wear and tear under normal usage.

B. CONTRACTOR's obligation to perform and complete the Work in accordance with the Contract Documents shall be absolute. None of the following will constitute an acceptance of Work that is not in accordance with the Contract Documents or a release of CONTRACTOR's obligation to perform the Work in accordance with the Contract Documents:

1. observations by ENGINEER;
2. recommendation by ENGINEER or payment by OWNER of any progress or final payment;
3. the issuance of a certificate of Substantial Completion by ENGINEER or any payment related thereto by OWNER;
4. use or occupancy of the Work or any part thereof by OWNER;
5. any acceptance by OWNER or any failure to do so;
6. any review and approval of a Shop Drawing or Sample submittal or the issuance of a notice of acceptability by ENGINEER;

7. any inspection, test, or approval by others; or

8. any correction of defective Work by OWNER.

6.20 *Indemnification*

A. To the fullest extent permitted by Laws and Regulations, CONTRACTOR shall indemnify and hold harmless OWNER, ENGINEER, ENGINEER's Consultants, and the officers, directors, partners, employees, agents, and other consultants and subcontractors of each and any of them from and against all claims, costs, losses, and damages (including but not limited to all fees and charges of engineers, architects, attorneys, and other professionals and all court or arbitration or other dispute resolution costs) arising out of or relating to the performance of the Work, provided that any such claim, cost, loss, or damage:

1. is attributable to bodily injury, sickness, disease, or death, or to injury to or destruction of tangible property (other than the Work itself), including the loss of use resulting therefrom; and
2. is caused in whole or in part by any negligent act or omission of CONTRACTOR, any Subcontractor, any Supplier, or any individual or entity directly or indirectly employed by any of them to perform any of the Work or anyone for whose acts any of them may be liable, regardless of whether or not caused in part by any negligence or omission of an individual or entity indemnified hereunder or whether liability is imposed upon such indemnified party by Laws and Regulations regardless of the negligence of any such individual or entity.

B. In any and all claims against OWNER or ENGINEER or any of their respective consultants, agents, officers, directors, partners, or employees by any employee (or the survivor or personal representative of such employee) of CONTRACTOR, any Subcontractor, any Supplier, or any individual or entity directly or indirectly employed by any of them to perform any of the Work, or anyone for whose acts any of them may be liable, the indemnification obligation under paragraph 6.20.A shall not be limited in any way by any limitation on the amount or type of damages, compensation, or benefits payable by or for CONTRACTOR or any such Subcontractor, Supplier, or other individual or entity under workers' compensation acts, disability benefit acts, or other employee benefit acts.

C. The indemnification obligations of CONTRACTOR under paragraph 6.20.A shall not extend to the liability of ENGINEER and ENGINEER's Consultants

or to the officers, directors, partners, employees, agents, and other consultants and subcontractors of each and any of them arising out of:

1. the preparation or approval of, or the failure to prepare or approve, maps, Drawings, opinions, reports, surveys, Change Orders, designs, or Specifications; or
2. giving directions or instructions, or failing to give them, if that is the primary cause of the injury or damage.

ARTICLE 7 - OTHER WORK

7.01 *Related Work at Site*

A. OWNER may perform other work related to the Project at the Site by OWNER's employees, or let other direct contracts therefor, or have other work performed by utility owners. If such other work is not noted in the Contract Documents, then:

1. written notice thereof will be given to CONTRACTOR prior to starting any such other work; and
2. if OWNER and CONTRACTOR are unable to agree on entitlement to or on the amount or extent, if any, of any adjustment in the Contract Price or Contract Times that should be allowed as a result of such other work, a Claim may be made therefor as provided in paragraph 10.05.

B. CONTRACTOR shall afford each other contractor who is a party to such a direct contract and each utility owner (and OWNER, if OWNER is performing the other work with OWNER's employees) proper and safe access to the Site and a reasonable opportunity for the introduction and storage of materials and equipment and the execution of such other work and shall properly coordinate the Work with theirs. Unless otherwise provided in the Contract Documents, CONTRACTOR shall do all cutting, fitting, and patching of the Work that may be required to properly connect or otherwise make its several parts come together and properly integrate with such other work. CONTRACTOR shall not endanger any work of others by cutting, excavating, or otherwise altering their work and will only cut or alter their work with the written consent of ENGINEER and the others whose work will be affected. The duties and responsibilities of CONTRACTOR under this paragraph are for the benefit of such utility owners and other contractors to the extent that there are comparable provisions for the benefit of CONTRACTOR in said direct contracts between OWNER and such utility owners and other contractors.

C. If the proper execution or results of any part of CONTRACTOR's Work depends upon work performed by others under this Article 7, CONTRACTOR shall inspect such other work and promptly report to ENGINEER in writing any delays, defects, or deficiencies in such other work that render it unavailable or unsuitable for the proper execution and results of CONTRACTOR's Work. CONTRACTOR's failure to so report will constitute an acceptance of such other work as fit and proper for integration with CONTRACTOR's Work except for latent defects and deficiencies in such other work.

7.02 *Coordination*

A. If OWNER intends to contract with others for the performance of other work on the Project at the Site, the following will be set forth in Supplementary Conditions:

1. the individual or entity who will have authority and responsibility for coordination of the activities among the various contractors will be identified;
2. the specific matters to be covered by such authority and responsibility will be itemized; and
3. the extent of such authority and responsibilities will be provided.

B. Unless otherwise provided in the Supplementary Conditions, OWNER shall have sole authority and responsibility for such coordination.

ARTICLE 8 - OWNER'S RESPONSIBILITIES

8.01 *Communications to Contractor*

A. Except as otherwise provided in these General Conditions, OWNER shall issue all communications to CONTRACTOR through ENGINEER.

8.02 *Replacement of ENGINEER*

A. In case of termination of the employment of ENGINEER, OWNER shall appoint an engineer to whom CONTRACTOR makes no reasonable objection, whose status under the Contract Documents shall be that of the former ENGINEER.

8.03 *Furnish Data*

A. OWNER shall promptly furnish the data required of OWNER under the Contract Documents.

8.04 *Pay Promptly When Due*

A. OWNER shall make payments to CONTRACTOR promptly when they are due as provided in paragraphs 14.02.C and 14.07.C.

8.05 *Lands and Easements; Reports and Tests*

A. OWNER's duties in respect of providing lands and easements and providing engineering surveys to establish reference points are set forth in paragraphs 4.01 and 4.05. Paragraph 4.02 refers to OWNER's identifying and making available to CONTRACTOR copies of reports of explorations and tests of subsurface conditions and drawings of physical conditions in or relating to existing surface or subsurface structures at or contiguous to the Site that have been utilized by ENGINEER in preparing the Contract Documents.

8.06 *Insurance*

A. OWNER's responsibilities, if any, in respect to purchasing and maintaining liability and property insurance are set forth in Article 5.

8.07 *Change Orders*

A. OWNER is obligated to execute Change Orders as indicated in paragraph 10.03.

8.08 *Inspections, Tests, and Approvals*

A. OWNER's responsibility in respect to certain inspections, tests, and approvals is set forth in paragraph 13.03.B.

8.09 *Limitations on OWNER's Responsibilities*

A. The OWNER shall not supervise, direct, or have control or authority over, nor be responsible for, CONTRACTOR's means, methods, techniques, sequences, or procedures of construction, or the safety precautions and programs incident thereto, or for any failure of CONTRACTOR to comply with Laws and Regulations applicable to the performance of the Work. OWNER will not be responsible for CONTRACTOR's failure to perform the Work in accordance with the Contract Documents.

8.10 *Undisclosed Hazardous Environmental Condition*

A. OWNER's responsibility in respect to an undisclosed Hazardous Environmental Condition is set forth in paragraph 4.06.

8.11 *Evidence of Financial Arrangements*

A. If and to the extent OWNER has agreed to furnish CONTRACTOR reasonable evidence that financial arrangements have been made to satisfy

OWNER's obligations under the Contract Documents, OWNER's responsibility in respect thereof will be as set forth in the Supplementary Conditions.

ARTICLE 9 - ENGINEER'S STATUS DURING CONSTRUCTION

9.01 *OWNER'S Representative*

A. ENGINEER will be OWNER's representative during the construction period. The duties and responsibilities and the limitations of authority of ENGINEER as OWNER's representative during construction are set forth in the Contract Documents and will not be changed without written consent of OWNER and ENGINEER.

9.02 *Visits to Site*

A. ENGINEER will make visits to the Site at intervals appropriate to the various stages of construction as ENGINEER deems necessary in order to observe as an experienced and qualified design professional the progress that has been made and the quality of the various aspects of CONTRACTOR's executed Work. Based on information obtained during such visits and observations, ENGINEER, for the benefit of OWNER, will determine, in general, if the Work is proceeding in accordance with the Contract Documents. ENGINEER will not be required to make exhaustive or continuous inspections on the Site to check the quality or quantity of the Work. ENGINEER's efforts will be directed toward providing for OWNER a greater degree of confidence that the completed Work will conform generally to the Contract Documents. On the basis of such visits and observations, ENGINEER will keep OWNER informed of the progress of the Work and will endeavor to guard OWNER against defective Work.

B. ENGINEER's visits and observations are subject to all the limitations on ENGINEER's authority and responsibility set forth in paragraph 9.10, and particularly, but without limitation, during or as a result of ENGINEER's visits or observations of CONTRACTOR's Work ENGINEER will not supervise, direct, control, or have authority over or be responsible for CONTRACTOR's means, methods, techniques, sequences, or procedures of construction, or the safety precautions and programs incident thereto, or for any failure of CONTRACTOR to comply with Laws and Regulations applicable to the performance of the Work.

9.03 *Project Representative*

A. If OWNER and ENGINEER agree, ENGINEER will furnish a Resident Project Representative to assist ENGINEER in providing more extensive observation of the Work. The responsibilities and authority and limitations thereon of any such Resident

Project Representative and assistants will be as provided in paragraph 9.10 and in the Supplementary Conditions. If OWNER designates another representative or agent to represent OWNER at the Site who is not ENGINEER's Consultant, agent or employee, the responsibilities and authority and limitations thereon of such other individual or entity will be as provided in the Supplementary Conditions.

9.04 *Clarifications and Interpretations*

A. ENGINEER will issue with reasonable promptness such written clarifications or interpretations of the requirements of the Contract Documents as ENGINEER may determine necessary, which shall be consistent with the intent of and reasonably inferable from the Contract Documents. Such written clarifications and interpretations will be binding on OWNER and CONTRACTOR. If OWNER and CONTRACTOR are unable to agree on entitlement to or on the amount or extent, if any, of any adjustment in the Contract Price or Contract Times, or both, that should be allowed as a result of a written clarification or interpretation, a Claim may be made therefor as provided in paragraph 10.05.

9.05 *Authorized Variations in Work*

A. ENGINEER may authorize minor variations in the Work from the requirements of the Contract Documents which do not involve an adjustment in the Contract Price or the Contract Times and are compatible with the design concept of the completed Project as a functioning whole as indicated by the Contract Documents. ~~These may be accomplished by a Field Order and will be binding on OWNER and also on CONTRACTOR, who shall perform the Work involved promptly. If OWNER and CONTRACTOR are unable to agree on entitlement to or on the amount or extent, if any, of any adjustment in the Contract Price or Contract Times, or both, as a result of a Field Order, a Claim may be made therefor as provided in paragraph 10.05.~~

9.06 *Rejecting Defective Work*

A. ENGINEER will have authority to disapprove or reject Work which ENGINEER believes to be defective, or that ENGINEER believes will not produce a completed Project that conforms to the Contract Documents or that will prejudice the integrity of the design concept of the completed Project as a functioning whole as indicated by the Contract Documents. ENGINEER will also have authority to require special inspection or testing of the Work as provided in paragraph 13.04, whether or not the Work is fabricated, installed, or completed.

9.07 *Shop Drawings, Change Orders and Payments*

A. In connection with ENGINEER's authority as to Shop Drawings and Samples, see paragraph 6.17.

B. In connection with ENGINEER's authority as to Change Orders, see Articles 10, 11, and 12.

C. In connection with ENGINEER's authority as to Applications for Payment, see Article 14.

9.08 *Determinations for Unit Price Work*

A. ENGINEER will determine the actual quantities and classifications of Unit Price Work performed by CONTRACTOR. ENGINEER will review with CONTRACTOR the ENGINEER's preliminary determinations on such matters before rendering a written decision thereon (by recommendation of an Application for Payment or otherwise). ENGINEER's written decision thereon will be final and binding (except as modified by ENGINEER to reflect changed factual conditions or more accurate data) upon OWNER and CONTRACTOR, subject to the provisions of paragraph 10.05.

9.09 *Decisions on Requirements of Contract Documents and Acceptability of Work*

A. ENGINEER will be the initial interpreter of the requirements of the Contract Documents and judge of the acceptability of the Work thereunder. Claims, disputes and other matters relating to the acceptability of the Work, the quantities and classifications of Unit Price Work, the interpretation of the requirements of the Contract Documents pertaining to the performance of the Work, and Claims seeking changes in the Contract Price or Contract Times will be referred initially to ENGINEER in writing, in accordance with the provisions of paragraph 10.05, with a request for a formal decision.

B. When functioning as interpreter and judge under this paragraph 9.09, ENGINEER will not show partiality to OWNER or CONTRACTOR and will not be liable in connection with any interpretation or decision rendered in good faith in such capacity. The rendering of a decision by ENGINEER pursuant to this paragraph 9.09 with respect to any such Claim, dispute, or other matter (except any which have been waived by the making or acceptance of final payment as provided in paragraph 14.07) will be a condition precedent to any exercise by OWNER or CONTRACTOR of such rights or remedies as either may otherwise have under the Contract Documents or by Laws or Regulations in respect of any such Claim, dispute, or other matter.

9.10 *Limitations on ENGINEER's Authority and Responsibilities*

A. Neither ENGINEER's authority or responsibility under this Article 9 or under any other provision of the Contract Documents nor any decision made by ENGINEER in good faith either to exercise or not exercise such authority or responsibility or the undertaking,

exercise, or performance of any authority or responsibility by ENGINEER shall create, impose, or give rise to any duty in contract, tort, or otherwise owed by ENGINEER to CONTRACTOR, any Subcontractor, any Supplier, any other individual or entity, or to any surety for or employee or agent of any of them.

B. ENGINEER will not supervise, direct, control, or have authority over or be responsible for CONTRACTOR's means, methods, techniques, sequences, or procedures of construction, or the safety precautions and programs incident thereto, or for any failure of CONTRACTOR to comply with Laws and Regulations applicable to the performance of the Work. ENGINEER will not be responsible for CONTRACTOR's failure to perform the Work in accordance with the Contract Documents.

C. ENGINEER will not be responsible for the acts or omissions of CONTRACTOR or of any Subcontractor, any Supplier, or of any other individual or entity performing any of the Work.

D. ENGINEER's review of the final Application for Payment and accompanying documentation and all maintenance and operating instructions, schedules, guarantees, Bonds, certificates of inspection, tests and approvals, and other documentation required to be delivered by paragraph 14.07.A will only be to determine generally that their content complies with the requirements of, and in the case of certificates of inspections, tests, and approvals that the results certified indicate compliance with, the Contract Documents.

E. The limitations upon authority and responsibility set forth in this paragraph 9.10 shall also apply to ENGINEER's Consultants, Resident Project Representative, and assistants.

ARTICLE 10 - CHANGES IN THE WORK; CLAIMS

10.01 *Authorized Changes in the Work*

A. Without invalidating the Agreement and without notice to any surety, OWNER may, at any time or from time to time, order additions, deletions, or revisions in the Work by a Written Amendment, a Change Order, or a Work Change Directive. Upon receipt of any such document, CONTRACTOR shall promptly proceed with the Work involved which will be performed under the applicable conditions of the Contract Documents (except as otherwise specifically provided).

B. If OWNER and CONTRACTOR are unable to agree on entitlement to, or on the amount or extent, if any, of an adjustment in the Contract Price or Contract Times, or both, that should be allowed as a result of a Work Change Directive, a Claim may be made therefor as provided in paragraph 10.05.

10.02 *Unauthorized Changes in the Work*

A. CONTRACTOR shall not be entitled to an increase in the Contract Price or an extension of the Contract Times with respect to any work performed that is not required by the Contract Documents as amended, modified, or supplemented as provided in paragraph 3.04, except in the case of an emergency as provided in paragraph 6.16 or in the case of uncovering Work as provided in paragraph 13.04.B.

10.03 *Execution of Change Orders*

A. OWNER and CONTRACTOR shall execute appropriate Change Orders recommended by ENGINEER (or Written Amendments) covering:

1. changes in the Work which are: (i) ordered by OWNER pursuant to paragraph 10.01.A, (ii) required because of acceptance of defective Work under paragraph 13.08.A or OWNER's correction of defective Work under paragraph 13.09, or (iii) agreed to by the parties;

2. changes in the Contract Price or Contract Times which are agreed to by the parties, including any undisputed sum or amount of time for Work actually performed in accordance with a Work Change Directive; and

3. changes in the Contract Price or Contract Times which embody the substance of any written decision rendered by ENGINEER pursuant to paragraph 10.05; provided that, in lieu of executing any such Change Order, an appeal may be taken from any such decision in accordance with the provisions of the Contract Documents and applicable Laws and Regulations, but during any such appeal, CONTRACTOR shall carry on the Work and adhere to the progress schedule as provided in paragraph 6.18.A.

10.04 *Notification to Surety*

A. If notice of any change affecting the general scope of the Work or the provisions of the Contract Documents (including, but not limited to, Contract Price or Contract Times) is required by the provisions of any Bond to be given to a surety, the giving of any such notice will be CONTRACTOR's responsibility. The amount of each applicable Bond will be adjusted to reflect the effect of any such change.

10.05 *Claims and Disputes*

A. *Notice:* Written notice stating the general nature of each Claim, dispute, or other matter shall be delivered by the claimant to ENGINEER and the other party to the Contract promptly (but in no event later than 30 days) after the start of the event giving rise

thereto. Notice of the amount or extent of the Claim, dispute, or other matter with supporting data shall be delivered to the ENGINEER and the other party to the Contract within 60 days after the start of such event (unless ENGINEER allows additional time for claimant to submit additional or more accurate data in support of such Claim, dispute, or other matter). A Claim for an adjustment in Contract Price shall be prepared in accordance with the provisions of paragraph 12.01.B. A Claim for an adjustment in Contract Time shall be prepared in accordance with the provisions of paragraph 12.02.B. Each Claim shall be accompanied by claimant's written statement that the adjustment claimed is the entire adjustment to which the claimant believes it is entitled as a result of said event. The opposing party shall submit any response to ENGINEER and the claimant within 30 days after receipt of the claimant's last submittal (unless ENGINEER allows additional time).

B. *ENGINEER's Decision:* ENGINEER will render a formal decision in writing within 30 days after receipt of the last submittal of the claimant or the last submittal of the opposing party, if any. ENGINEER's written decision on such Claim, dispute, or other matter will be final and binding upon OWNER and CONTRACTOR unless:

1. an appeal from ENGINEER's decision is taken within the time limits and in accordance with the dispute resolution procedures set forth in Article 16; or

2. if no such dispute resolution procedures have been set forth in Article 16, a written notice of intention to appeal from ENGINEER's written decision is delivered by OWNER or CONTRACTOR to the other and to ENGINEER within 30 days after the date of such decision, and a formal proceeding is instituted by the appealing party in a forum of competent jurisdiction within 60 days after the date of such decision or within 60 days after Substantial Completion, whichever is later (unless otherwise agreed in writing by OWNER and CONTRACTOR), to exercise such rights or remedies as the appealing party may have with respect to such Claim, dispute, or other matter in accordance with applicable Laws and Regulations.

C. If ENGINEER does not render a formal decision in writing within the time stated in paragraph 10.05.B, a decision denying the Claim in its entirety shall be deemed to have been issued 31 days after receipt of the last submittal of the claimant or the last submittal of the opposing party, if any.

D. No Claim for an adjustment in Contract Price or Contract Times (or Milestones) will be valid if not submitted in accordance with this paragraph 10.05.

ARTICLE 11 - COST OF THE WORK; CASH ALLOWANCES; UNIT PRICE WORK

11.01 *Cost of the Work*

A. *Costs Included:* The term Cost of the Work means the sum of all costs necessarily incurred and paid by CONTRACTOR in the proper performance of the Work. When the value of any Work covered by a Change Order or when a Claim for an adjustment in Contract Price is determined on the basis of Cost of the Work, the costs to be reimbursed to CONTRACTOR will be only those additional or incremental costs required because of the change in the Work or because of the event giving rise to the Claim. Except as otherwise may be agreed to in writing by OWNER, such costs shall be in amounts no higher than those prevailing in the locality of the Project, shall include only the following items, and shall not include any of the costs itemized in paragraph 11.01.B.

~~1. Payroll costs for employees in the direct employ of CONTRACTOR in the performance of the Work under schedules of job classifications agreed upon by OWNER and CONTRACTOR. Such employees shall include without limitation superintendents, foremen, and other personnel employed full time at the Site. Payroll costs for employees not employed full time on the Work shall be apportioned on the basis of their time spent on the Work. Payroll costs shall include, but not be limited to, salaries and wages plus the cost of fringe benefits, which shall include social security contributions, unemployment, excise, and payroll taxes, workers' compensation, health and retirement benefits, bonuses, sick leave, vacation and holiday pay applicable thereto. The expenses of performing Work outside of regular working hours, on Saturday, Sunday, or legal holidays, shall be included in the above to the extent authorized by OWNER.~~

2. Cost of all materials and equipment furnished and incorporated in the Work, including costs of transportation and storage thereof, and Suppliers' field services required in connection therewith. All cash discounts shall accrue to CONTRACTOR unless OWNER deposits funds with CONTRACTOR with which to make payments, in which case the cash discounts shall accrue to OWNER. All trade discounts, rebates and refunds and returns from sale of surplus materials and equipment shall accrue to OWNER, and CONTRACTOR shall make provisions so that they may be obtained.

3. Payments made by CONTRACTOR to Subcontractors for Work performed by

Subcontractors. If required by OWNER, CONTRACTOR shall obtain competitive bids from subcontractors acceptable to OWNER and CONTRACTOR and shall deliver such bids to OWNER, who will then determine, with the advice of ENGINEER, which bids, if any, will be acceptable. If any subcontract provides that the Subcontractor is to be paid on the basis of Cost of the Work plus a fee, the Subcontractor's Cost of the Work and fee shall be determined in the same manner as CONTRACTOR's Cost of the Work and fee as provided in this paragraph 11.01.

4. Costs of special consultants (including but not limited to engineers, architects, testing laboratories, surveyors, attorneys, and accountants) employed for services specifically related to the Work.

5. Supplemental costs including the following:

a. The proportion of necessary transportation, travel, and subsistence expenses of CONTRACTOR's employees incurred in discharge of duties connected with the Work.

b. Cost, including transportation and maintenance, of all materials, supplies, equipment, machinery, appliances, office, and temporary facilities at the Site, and hand tools not owned by the workers, which are consumed in the performance of the Work, and cost, less market value, of such items used but not consumed which remain the property of CONTRACTOR.

c. Rentals of all construction equipment and machinery, and the parts thereof whether rented from CONTRACTOR or others in accordance with rental agreements approved by OWNER with the advice of ENGINEER, and the costs of transportation, loading, unloading, assembly, dismantling, and removal thereof. All such costs shall be in accordance with the terms of said rental agreements. The rental of any such equipment, machinery, or parts shall cease when the use thereof is no longer necessary for the Work.

d. Sales, consumer, use, and other similar taxes related to the Work, and for which CONTRACTOR is liable, imposed by Laws and Regulations.

e. Deposits lost for causes other than negligence of CONTRACTOR, any Subcontractor, or anyone directly or indirectly employed by any of them or for whose acts any of them may be liable, and royalty payments and fees for permits and licenses.

f. Losses and damages (and related expenses) caused by damage to the Work, not compensated by insurance or otherwise, sustained by CONTRACTOR in connection with the performance of the Work (except losses and damages within the deductible amounts of property insurance established in accordance with paragraph 5.06.D), provided such losses and damages have resulted from causes other than the negligence of CONTRACTOR, any Subcontractor, or anyone directly or indirectly employed by any of them or for whose acts any of them may be liable. Such losses shall include settlements made with the written consent and approval of OWNER. No such losses, damages, and expenses shall be included in the Cost of the Work for the purpose of determining CONTRACTOR's fee.

g. The cost of utilities, fuel, and sanitary facilities at the Site.

h. Minor expenses such as telegrams, long distance telephone calls, telephone service at the Site, expressage, and similar petty cash items in connection with the Work.

i. When the Cost of the Work is used to determine the value of a Change Order or of a Claim, the cost of premiums for additional Bonds and insurance required because of the changes in the Work or caused by the event giving rise to the Claim.

j. When all the Work is performed on the basis of cost-plus, the costs of premiums for all Bonds and insurance CONTRACTOR is required by the Contract Documents to purchase and maintain.

B. *Costs Excluded:* The term Cost of the Work shall not include any of the following items:

1. Payroll costs and other compensation of CONTRACTOR's officers, executives, principals (of partnerships and sole proprietorships), general managers, engineers, architects, estimators, attorneys, auditors, accountants, purchasing and contracting agents, expeditors, timekeepers, clerks, and other personnel employed by CONTRACTOR, whether at the Site or in CONTRACTOR's principal or branch office for general administration of the Work and not specifically included in the agreed upon schedule of job classifications referred to in paragraph 11.01.A.1 or specifically covered by paragraph 11.01.A.4, all of which are to be considered administrative costs covered by the CONTRACTOR's fee.

2. Expenses of CONTRACTOR's principal and branch offices other than CONTRACTOR's office at the Site.

3. Any part of CONTRACTOR's capital expenses, including interest on CONTRACTOR's capital employed for the Work and charges against CONTRACTOR for delinquent payments.

4. Costs due to the negligence of CONTRACTOR, any Subcontractor, or anyone directly or indirectly employed by any of them or for whose acts any of them may be liable, including but not limited to, the correction of defective Work, disposal of materials or equipment wrongly supplied, and making good any damage to property.

5. Other overhead or general expense costs of any kind and the costs of any item not specifically and expressly included in paragraphs 11.01.A and 11.01.B.

C. *CONTRACTOR's Fee:* When all the Work is performed on the basis of cost-plus, CONTRACTOR's fee shall be determined as set forth in the Agreement. When the value of any Work covered by a Change Order or when a Claim for an adjustment in Contract Price is determined on the basis of Cost of the Work, CONTRACTOR's fee shall be determined as set forth in paragraph 12.01.C.

D. *Documentation:* Whenever the Cost of the Work for any purpose is to be determined pursuant to paragraphs 11.01.A and 11.01.B, CONTRACTOR will establish and maintain records thereof in accordance with generally accepted accounting practices and submit in a form acceptable to ENGINEER an itemized cost breakdown together with supporting data.

11.02 *Cash Allowances*

A. It is understood that CONTRACTOR has included in the Contract Price all allowances so named in the Contract Documents and shall cause the Work so covered to be performed for such sums as may be acceptable to OWNER and ENGINEER. CONTRACTOR agrees that:

1. the allowances include the cost to CONTRACTOR (less any applicable trade discounts) of materials and equipment required by the allowances to be delivered at the Site, and all applicable taxes; and

2. CONTRACTOR's costs for unloading and handling on the Site, labor, installation costs, overhead, profit, and other expenses contemplated for the allowances have been included in the Contract Price and not in the allowances, and no demand for additional

payment on account of any of the foregoing will be valid.

B. Prior to final payment, an appropriate Change Order will be issued as recommended by ENGINEER to reflect actual amounts due CONTRACTOR on account of Work covered by allowances, and the Contract Price shall be correspondingly adjusted.

11.03 *Unit Price Work*

A. Where the Contract Documents provide that all or part of the Work is to be Unit Price Work, initially the Contract Price will be deemed to include for all Unit Price Work an amount equal to the sum of the unit price for each separately identified item of Unit Price Work times the estimated quantity of each item as indicated in the Agreement. The estimated quantities of items of Unit Price Work are not guaranteed and are solely for the purpose of comparison of Bids and determining an initial Contract Price. Determinations of the actual quantities and classifications of Unit Price Work performed by CONTRACTOR will be made by ENGINEER subject to the provisions of paragraph 9.08.

B. Each unit price will be deemed to include an amount considered by CONTRACTOR to be adequate to cover CONTRACTOR's overhead and profit for each separately identified item.

C. OWNER or CONTRACTOR may make a Claim for an adjustment in the Contract Price in accordance with paragraph 10.05 if:

1. the quantity of any item of Unit Price Work performed by CONTRACTOR differs materially and significantly from the estimated quantity of such item indicated in the Agreement; and

2. there is no corresponding adjustment with respect any other item of Work; and

3. if CONTRACTOR believes that CONTRACTOR is entitled to an increase in Contract Price as a result of having incurred additional expense or OWNER believes that OWNER is entitled to a decrease in Contract Price and the parties are unable to agree as to the amount of any such increase or decrease.

ARTICLE 12 - CHANGE OF CONTRACT PRICE; CHANGE OF CONTRACT TIMES

12.01 *Change of Contract Price*

A. The Contract Price may only be changed by a Change Order or by a Written Amendment. Any Claim for an adjustment in the Contract Price shall be based

on written notice submitted by the party making the Claim to the ENGINEER and the other party to the Contract in accordance with the provisions of paragraph 10.05.

B. The value of any Work covered by a Change Order or of any Claim for an adjustment in the Contract Price will be determined as follows:

1. where the Work involved is covered by unit prices contained in the Contract Documents, by application of such unit prices to the quantities of the items involved (subject to the provisions of paragraph 11.03); or

2. where the Work involved is not covered by unit prices contained in the Contract Documents, by a mutually agreed lump sum (which may include an allowance for overhead and profit not necessarily in accordance with paragraph 12.01.C.2); or

3. where the Work involved is not covered by unit prices contained in the Contract Documents and agreement to a lump sum is not reached under paragraph 12.01.B.2, on the basis of the Cost of the Work (determined as provided in paragraph 11.01) plus a CONTRACTOR's fee for overhead and profit (determined as provided in paragraph 12.01.C).

C. *CONTRACTOR's Fee*: The CONTRACTOR's fee for overhead and profit shall be determined as follows:

1. a mutually acceptable fixed fee; or

2. if a fixed fee is not agreed upon, then a fee based on the following percentages of the various portions of the Cost of the Work:

a. for costs incurred under paragraphs 11.01.A.1 and 11.01.A.2, the CONTRACTOR's fee shall be 15 percent;

b. for costs incurred under paragraph 11.01.A.3, the CONTRACTOR's fee shall be five percent;

c. where one or more tiers of subcontracts are on the basis of Cost of the Work plus a fee and no fixed fee is agreed upon, the intent of paragraph 12.01.C.2.a is that the Subcontractor who actually performs the Work, at whatever tier, will be paid a fee of 15 percent of the costs incurred by such Subcontractor under paragraphs 11.01.A.1 and 11.01.A.2 and that any higher tier Subcontractor and CONTRACTOR will each be paid a fee of five percent of the amount paid to the next lower tier Subcontractor;

d. no fee shall be payable on the basis of costs itemized under paragraphs 11.01.A.4, 11.01.A.5, and 11.01.B;

e. the amount of credit to be allowed by CONTRACTOR to OWNER for any change which results in a net decrease in cost will be the amount of the actual net decrease in cost plus a deduction in CONTRACTOR's fee by an amount equal to five percent of such net decrease; and

f. when both additions and credits are involved in any one change, the adjustment in CONTRACTOR's fee shall be computed on the basis of the net change in accordance with paragraphs 12.01.C.2.a through 12.01.C.2.e, inclusive.

12.02 *Change of Contract Times*

A. The Contract Times (or Milestones) may only be changed by a Change Order or by a Written Amendment. Any Claim for an adjustment in the Contract Times (or Milestones) shall be based on written notice submitted by the party making the claim to the ENGINEER and the other party to the Contract in accordance with the provisions of paragraph 10.05.

B. Any adjustment of the Contract Times (or Milestones) covered by a Change Order or of any Claim for an adjustment in the Contract Times (or Milestones) will be determined in accordance with the provisions of this Article 12.

12.03 *Delays Beyond CONTRACTOR's Control*

A. Where CONTRACTOR is prevented from completing any part of the Work within the Contract Times (or Milestones) due to delay beyond the control of CONTRACTOR, the Contract Times (or Milestones) will be extended in an amount equal to the time lost due to such delay if a Claim is made therefor as provided in paragraph 12.02.A. Delays beyond the control of CONTRACTOR shall include, but not be limited to, acts or neglect by OWNER, acts or neglect of utility owners or other contractors performing other work as contemplated by Article 7, fires, floods, epidemics, abnormal weather conditions, or acts of God.

12.04 *Delays Within CONTRACTOR's Control*

A. The Contract Times (or Milestones) will not be extended due to delays within the control of CONTRACTOR. Delays attributable to and within the control of a Subcontractor or Supplier shall be deemed to be delays within the control of CONTRACTOR.

12.05 *Delays Beyond OWNER's and CONTRACTOR's Control*

A. Where CONTRACTOR is prevented from completing any part of the Work within the Contract Times (or Milestones) due to delay beyond the control of both OWNER and CONTRACTOR, an extension of the Contract Times (or Milestones) in an amount equal to the time lost due to such delay shall be CONTRACTOR's sole and exclusive remedy for such delay.

12.06 *Delay Damages*

A. In no event shall OWNER or ENGINEER be liable to CONTRACTOR, any Subcontractor, any Supplier, or any other person or organization, or to any surety for or employee or agent of any of them, for damages arising out of or resulting from:

1. delays caused by or within the control of CONTRACTOR; or
2. delays beyond the control of both OWNER and CONTRACTOR including but not limited to fires, floods, epidemics, abnormal weather conditions, acts of God, or acts or neglect by utility owners or other contractors performing other work as contemplated by Article 7.

B. Nothing in this paragraph 12.06 bars a change in Contract Price pursuant to this Article 12 to compensate CONTRACTOR due to delay, interference, or disruption directly attributable to actions or inactions of OWNER or anyone for whom OWNER is responsible.

ARTICLE 13 - TESTS AND INSPECTIONS; CORRECTION, REMOVAL OR ACCEPTANCE OF DEFECTIVE WORK

13.01 *Notice of Defects*

A. Prompt notice of all defective Work of which OWNER or ENGINEER has actual knowledge will be given to CONTRACTOR. All defective Work may be rejected, corrected, or accepted as provided in this Article 13.

13.02 *Access to Work*

A. OWNER, ENGINEER, ENGINEER's Consultants, other representatives and personnel of OWNER, independent testing laboratories, and governmental agencies with jurisdictional interests will have access to the Site and the Work at reasonable times for their observation, inspecting, and testing. CONTRACTOR shall provide them proper and safe conditions for such access and advise them of CONTRACTOR's Site safety procedures and programs so that they may comply therewith as applicable.

13.03 *Tests and Inspections*

A. CONTRACTOR shall give ENGINEER timely notice of readiness of the Work for all required inspections, tests, or approvals and shall cooperate with inspection and testing personnel to facilitate required inspections or tests.

~~B. OWNER shall employ and pay for the services of an independent testing laboratory to perform all inspections, tests, or approvals required by the Contract Documents except:~~

- ~~1. for inspections, tests, or approvals covered by paragraphs 13.03.C and 13.03.D below;~~
- ~~2. that costs incurred in connection with tests or inspections conducted pursuant to paragraph 13.04.B shall be paid as provided in said paragraph 13.04.B; and~~
- ~~3. as otherwise specifically provided in the Contract Documents.~~

C. If Laws or Regulations of any public body having jurisdiction require any Work (or part thereof) specifically to be inspected, tested, or approved by an employee or other representative of such public body, CONTRACTOR shall assume full responsibility for arranging and obtaining such inspections, tests, or approvals, pay all costs in connection therewith, and furnish ENGINEER the required certificates of inspection or approval.

D. CONTRACTOR shall be responsible for arranging and obtaining and shall pay all costs in connection with any inspections, tests, or approvals required for OWNER's and ENGINEER's acceptance of materials or equipment to be incorporated in the Work; or acceptance of materials, mix designs, or equipment submitted for approval prior to CONTRACTOR's purchase thereof for incorporation in the Work. Such inspections, tests, or approvals shall be performed by organizations acceptable to OWNER and ENGINEER.

E. If any Work (or the work of others) that is to be inspected, tested, or approved is covered by CONTRACTOR without written concurrence of ENGINEER, it must, if requested by ENGINEER, be uncovered for observation.

F. Uncovering Work as provided in paragraph 13.03.E shall be at CONTRACTOR's expense unless CONTRACTOR has given ENGINEER timely notice of CONTRACTOR's intention to cover the same and ENGINEER has not acted with reasonable promptness in response to such notice.

13.04 *Uncovering Work*

A. If any Work is covered contrary to the written request of ENGINEER, it must, if requested by ENGINEER, be uncovered for ENGINEER's observation and replaced at CONTRACTOR's expense.

B. If ENGINEER considers it necessary or advisable that covered Work be observed by ENGINEER or inspected or tested by others, CONTRACTOR, at ENGINEER's request, shall uncover, expose, or otherwise make available for observation, inspection, or testing as ENGINEER may require, that portion of the Work in question, furnishing all necessary labor, material, and equipment. If it is found that such Work is defective, CONTRACTOR shall pay all Claims, costs, losses, and damages (including but not limited to all fees and charges of engineers, architects, attorneys, and other professionals and all court or arbitration or other dispute resolution costs) arising out of or relating to such uncovering, exposure, observation, inspection, and testing, and of satisfactory replacement or reconstruction (including but not limited to all costs of repair or replacement of work of others); and OWNER shall be entitled to an appropriate decrease in the Contract Price. If the parties are unable to agree as to the amount thereof, OWNER may make a Claim therefor as provided in paragraph 10.05. If, however, such Work is not found to be defective, CONTRACTOR shall be allowed an increase in the Contract Price or an extension of the Contract Times (or Milestones), or both, directly attributable to such uncovering, exposure, observation, inspection, testing, replacement, and reconstruction. If the parties are unable to agree as to the amount or extent thereof, CONTRACTOR may make a Claim therefor as provided in paragraph 10.05.

13.05 *OWNER May Stop the Work*

~~A. If the Work is defective, or CONTRACTOR fails to supply sufficient skilled workers or suitable materials or equipment, or fails to perform the Work in such a way that the completed Work will conform to the Contract Documents, OWNER may order CONTRACTOR to stop the Work, or any portion thereof, until the cause for such order has been eliminated; however, this right of OWNER to stop the Work shall not give rise to any duty on the part of OWNER to exercise this right for the benefit of CONTRACTOR, any Subcontractor, any Supplier, any other individual or entity, or any surety for, or employee or agent of any of them.~~

13.06 *Correction or Removal of Defective Work*

A. CONTRACTOR shall correct all defective Work, whether or not fabricated, installed, or completed, or, if the Work has been rejected by ENGINEER, remove it from the Project and replace it with Work that is not defective. CONTRACTOR shall pay all Claims, costs, losses, and damages (including but not limited to all fees and charges of engineers, architects, attorneys, and other professionals and all court or arbitration or other dispute resolution costs) arising out of or relating to such correction or removal (including but not limited to all costs of repair or replacement of work of others).

13.07 *Correction Period*

~~A. If within one year after the date of Substantial Completion or such longer period of time as may be prescribed by Laws or Regulations or by the terms of any applicable special guarantee required by the Contract Documents or by any specific provision of the Contract Documents, any Work is found to be defective, or if the repair of any damages to the land or areas made available for CONTRACTOR's use by OWNER or permitted by Laws and Regulations as contemplated in paragraph 6.11.A is found to be defective, CONTRACTOR shall promptly, without cost to OWNER and in accordance with OWNER's written instructions: (i) repair such defective land or areas, or (ii) correct such defective Work or, if the defective Work has been rejected by OWNER, remove it from the Project and replace it with Work that is not defective, and (iii) satisfactorily correct or repair or remove and replace any damage to other Work, to the work of others or other land or areas resulting therefrom. If CONTRACTOR does not promptly comply with the terms of such instructions, or in an emergency where delay would cause serious risk of loss or damage, OWNER may have the defective Work corrected or repaired or may have the rejected Work removed and replaced, and all Claims, costs, losses, and damages (including but not limited to all fees and charges of engineers, architects, attorneys, and other professionals and all court or arbitration or other dispute resolution costs) arising out of or relating to such correction or repair or such removal and replacement (including but not limited to all costs of repair or replacement of work of others) will be paid by CONTRACTOR.~~

~~B. In special circumstances where a particular item of equipment is placed in continuous service before Substantial Completion of all the Work, the correction period for that item may start to run from an earlier date if so provided in the Specifications or by Written Amendment.~~

C. Where defective Work (and damage to other Work resulting therefrom) has been corrected or removed and replaced under this paragraph 13.07, the correction period hereunder with respect to such Work

will be extended for an additional period of one year after such correction or removal and replacement has been satisfactorily completed.

D. CONTRACTOR's obligations under this paragraph 13.07 are in addition to any other obligation or warranty. The provisions of this paragraph 13.07 shall not be construed as a substitute for or a waiver of the provisions of any applicable statute of limitation or repose.

13.08 *Acceptance of Defective Work*

A. If, instead of requiring correction or removal and replacement of defective Work, OWNER (and, prior to ENGINEER's recommendation of final payment, ENGINEER) prefers to accept it, OWNER may do so. CONTRACTOR shall pay all Claims, costs, losses, and damages (including but not limited to all fees and charges of engineers, architects, attorneys, and other professionals and all court or arbitration or other dispute resolution costs) attributable to OWNER's evaluation of and determination to accept such defective Work (such costs to be approved by ENGINEER as to reasonableness) and the diminished value of the Work to the extent not otherwise paid by CONTRACTOR pursuant to this sentence. If any such acceptance occurs prior to ENGINEER's recommendation of final payment, a Change Order will be issued incorporating the necessary revisions in the Contract Documents with respect to the Work, and OWNER shall be entitled to an appropriate decrease in the Contract Price, reflecting the diminished value of Work so accepted. If the parties are unable to agree as to the amount thereof, OWNER may make a Claim therefor as provided in paragraph 10.05. If the acceptance occurs after such recommendation, an appropriate amount will be paid by CONTRACTOR to OWNER.

13.09 *OWNER May Correct Defective Work*

A. If CONTRACTOR fails within a reasonable time after written notice from ENGINEER to correct defective Work or to remove and replace rejected Work as required by ENGINEER in accordance with paragraph 13.06.A, or if CONTRACTOR fails to perform the Work in accordance with the Contract Documents, or if CONTRACTOR fails to comply with any other provision of the Contract Documents, OWNER may, after seven days written notice to CONTRACTOR, correct and remedy any such deficiency.

B. In exercising the rights and remedies under this paragraph, OWNER shall proceed expeditiously. In connection with such corrective and remedial action, OWNER may exclude CONTRACTOR from all or part of the Site, take possession of all or part of the Work and suspend CONTRACTOR's services related thereto, take possession of CONTRACTOR's tools, appliances, construction equipment and machinery at the Site, and incorporate in the Work all materials and

equipment stored at the Site or for which OWNER has paid CONTRACTOR but which are stored elsewhere. CONTRACTOR shall allow OWNER, OWNER's representatives, agents and employees, OWNER's other contractors, and ENGINEER and ENGINEER's Consultants access to the Site to enable OWNER to exercise the rights and remedies under this paragraph.

C. All Claims, costs, losses, and damages (including but not limited to all fees and charges of engineers, architects, attorneys, and other professionals and all court or arbitration or other dispute resolution costs) incurred or sustained by OWNER in exercising the rights and remedies under this paragraph 13.09 will be charged against CONTRACTOR, and a Change Order will be issued incorporating the necessary revisions in the Contract Documents with respect to the Work; and OWNER shall be entitled to an appropriate decrease in the Contract Price. If the parties are unable to agree as to the amount of the adjustment, OWNER may make a Claim therefor as provided in paragraph 10.05. Such claims, costs, losses and damages will include but not be limited to all costs of repair, or replacement of work of others destroyed or damaged by correction, removal, or replacement of CONTRACTOR's defective Work.

D. CONTRACTOR shall not be allowed an extension of the Contract Times (or Milestones) because of any delay in the performance of the Work attributable to the exercise by OWNER of OWNER's rights and remedies under this paragraph 13.09.

ARTICLE 14 - PAYMENTS TO CONTRACTOR AND COMPLETION

14.01 *Schedule of Values*

A. The schedule of values established as provided in paragraph 2.07.A will serve as the basis for progress payments and will be incorporated into a form of Application for Payment acceptable to ENGINEER. Progress payments on account of Unit Price Work will be based on the number of units completed.

14.02 *Progress Payments*

A. *Applications for Payments*

1. At least 20 days before the date established for each progress payment (but not more often than once a month), CONTRACTOR shall submit to ENGINEER for review an Application for Payment filled out and signed by CONTRACTOR covering the Work completed as of the date of the Application and accompanied by such supporting documentation as is required by the Contract Documents. If payment is requested on the

basis of materials and equipment not incorporated in the Work but delivered and suitably stored at the Site or at another location agreed to in writing, the Application for Payment shall also be accompanied by a bill of sale, invoice, or other documentation warranting that OWNER has received the materials and equipment free and clear of all Liens and evidence that the materials and equipment are covered by appropriate property insurance or other arrangements to protect OWNER's interest therein, all of which must be satisfactory to OWNER.

2. Beginning with the second Application for Payment, each Application shall include an affidavit of CONTRACTOR stating that all previous progress payments received on account of the Work have been applied on account to discharge CONTRACTOR's legitimate obligations associated with prior Applications for Payment.

3. The amount of retainage with respect to progress payments will be as stipulated in the Agreement.

B. *Review of Applications*

1. ENGINEER will, within 10 days after receipt of each Application for Payment, either indicate in writing a recommendation of payment and present the Application to OWNER or return the Application to CONTRACTOR indicating in writing ENGINEER's reasons for refusing to recommend payment. In the latter case, CONTRACTOR may make the necessary corrections and resubmit the Application.

2. ENGINEER's recommendation of any payment requested in an Application for Payment will constitute a representation by ENGINEER to OWNER, based on ENGINEER's observations on the Site of the executed Work as an experienced and qualified design professional and on ENGINEER's review of the Application for Payment and the accompanying data and schedules, that to the best of ENGINEER's knowledge, information and belief:

a. the Work has progressed to the point indicated;

b. the quality of the Work is generally in accordance with the Contract Documents (subject to an evaluation of the Work as a functioning whole prior to or upon Substantial Completion, to the results of any subsequent tests called for in the Contract Documents, to a final determination of

quantities and classifications for Unit Price Work under paragraph 9.08, and to any other qualifications stated in the recommendation); and

c. The conditions precedent to CONTRACTOR's being entitled to such payment appear to have been fulfilled in so far as it is ENGINEER's responsibility to observe the Work.

3. By recommending any such payment ENGINEER will not thereby be deemed to have represented that: (i) inspections made to check the quality or the quantity of the Work as it has been performed have been exhaustive, extended to every aspect of the Work in progress, or involved detailed inspections of the Work beyond the responsibilities specifically assigned to ENGINEER in the Contract Documents; or (ii) that there may not be other matters or issues between the parties that might entitle CONTRACTOR to be paid additionally by OWNER or entitle OWNER to withhold payment to CONTRACTOR.

4. Neither ENGINEER's review of CONTRACTOR's Work for the purposes of recommending payments nor ENGINEER's recommendation of any payment, including final payment, will impose responsibility on ENGINEER to supervise, direct, or control the Work or for the means, methods, techniques, sequences, or procedures of construction, or the safety precautions and programs incident thereto, or for CONTRACTOR's failure to comply with Laws and Regulations applicable to CONTRACTOR's performance of the Work. Additionally, said review or recommendation will not impose responsibility on ENGINEER to make any examination to ascertain how or for what purposes CONTRACTOR has used the moneys paid on account of the Contract Price, or to determine that title to any of the Work, materials, or equipment has passed to OWNER free and clear of any Liens.

5. ENGINEER may refuse to recommend the whole or any part of any payment if, in ENGINEER's opinion, it would be incorrect to make the representations to OWNER referred to in paragraph 14.02.B.2. ENGINEER may also refuse to recommend any such payment or, because of subsequently discovered evidence or the results of subsequent inspections or tests, revise or revoke any such payment recommendation previously made, to such extent as may be necessary in ENGINEER's opinion to protect OWNER from loss because:

a. the Work is defective, or completed Work has been damaged, requiring correction or replacement;

b. the Contract Price has been reduced by Written Amendment or Change Orders;

c. OWNER has been required to correct defective Work or complete Work in accordance with paragraph 13.09; or

~~d. ENGINEER has actual knowledge of the occurrence of any of the events enumerated in paragraph 15.02.A.~~

C. *Payment Becomes Due*

~~1. Ten days after presentation of the Application for Payment to OWNER with ENGINEER's recommendation, the amount recommended will (subject to the provisions of paragraph 14.02.D) become due, and when due will be paid by OWNER to CONTRACTOR.~~

D. *Reduction in Payment*

1. OWNER may refuse to make payment of the full amount recommended by ENGINEER because:

a. claims have been made against OWNER on account of CONTRACTOR's performance or furnishing of the Work;

b. Liens have been filed in connection with the Work, except where CONTRACTOR has delivered a specific Bond satisfactory to OWNER to secure the satisfaction and discharge of such Liens;

c. there are other items entitling OWNER to a set-off against the amount recommended; or

d. OWNER has actual knowledge of the occurrence of any of the events enumerated in paragraphs 14.02.B.5.a through 14.02.B.5.c or paragraph 15.02.A.

2. If OWNER refuses to make payment of the full amount recommended by ENGINEER, OWNER must give CONTRACTOR immediate written notice (with a copy to ENGINEER) stating the reasons for such action and promptly pay CONTRACTOR any amount remaining after deduction of the amount so withheld. OWNER shall promptly pay CONTRACTOR the amount so withheld, or any adjustment thereto agreed to by OWNER and CONTRACTOR, when CONTRACTOR corrects to OWNER's satisfaction the reasons for such action.

3. If it is subsequently determined that OWNER's refusal of payment was not justified, the amount wrongfully withheld shall be treated as an amount due as determined by paragraph 14.02.C.1.

14.03 *CONTRACTOR's Warranty of Title*

A. CONTRACTOR warrants and guarantees that title to all Work, materials, and equipment covered by any Application for Payment, whether incorporated in the Project or not, will pass to OWNER no later than the time of payment free and clear of all Liens.

14.04 *Substantial Completion*

A. When CONTRACTOR considers the entire Work ready for its intended use CONTRACTOR shall notify OWNER and ENGINEER in writing that the entire Work is substantially complete (except for items specifically listed by CONTRACTOR as incomplete) and request that ENGINEER issue a certificate of Substantial Completion. Promptly thereafter, OWNER, CONTRACTOR, and ENGINEER shall make an inspection of the Work to determine the status of completion. If ENGINEER does not consider the Work substantially complete, ENGINEER will notify CONTRACTOR in writing giving the reasons therefore. ~~If ENGINEER considers the Work substantially complete, ENGINEER will prepare and deliver to OWNER a tentative certificate of Substantial Completion which shall fix the date of Substantial Completion. There shall be attached to the certificate a tentative list of items to be completed or corrected before final payment. OWNER shall have seven days after receipt of the tentative certificate during which to make written objection to ENGINEER as to any provisions of the certificate or attached list. If, after considering such objections, ENGINEER concludes that the Work is not substantially complete, ENGINEER will within 14 days after submission of the tentative certificate to OWNER notify CONTRACTOR in writing, stating the reasons therefor. If, after consideration of OWNER's objections, ENGINEER considers the Work substantially complete, ENGINEER will within said 14 days execute and deliver to OWNER and CONTRACTOR a definitive certificate of Substantial Completion (with a revised tentative list of items to be completed or corrected) reflecting such changes from the tentative certificate as ENGINEER believes justified after consideration of any objections from OWNER. At the time of delivery of the tentative certificate of Substantial Completion ENGINEER will deliver to OWNER and CONTRACTOR a written recommendation as to division of responsibilities pending final payment between OWNER and CONTRACTOR with respect to security, operation, safety, and protection of the Work, maintenance, heat, utilities, insurance, and warranties and guarantees. Unless OWNER and CONTRACTOR agree otherwise in writing and so inform ENGINEER in writing prior to ENGINEER's issuing the definitive~~

~~certificate of Substantial Completion, ENGINEER's aforesaid recommendation will be binding on OWNER and CONTRACTOR until final payment.~~

B. OWNER shall have the right to exclude CONTRACTOR from the Site after the date of Substantial Completion, but OWNER shall allow CONTRACTOR reasonable access to complete or correct items on the tentative list.

14.05 *Partial Utilization*

A. Use by OWNER at OWNER's option of any substantially completed part of the Work which has specifically been identified in the Contract Documents, or which OWNER, ENGINEER, and CONTRACTOR agree constitutes a separately functioning and usable part of the Work that can be used by OWNER for its intended purpose without significant interference with CONTRACTOR's performance of the remainder of the Work, may be accomplished prior to Substantial Completion of all the Work subject to the following conditions.

1. OWNER at any time may request CONTRACTOR in writing to permit OWNER to use any such part of the Work which OWNER believes to be ready for its intended use and substantially complete. If CONTRACTOR agrees that such part of the Work is substantially complete, CONTRACTOR will certify to OWNER and ENGINEER that such part of the Work is substantially complete and request ENGINEER to issue a certificate of Substantial Completion for that part of the Work. CONTRACTOR at any time may notify OWNER and ENGINEER in writing that CONTRACTOR considers any such part of the Work ready for its intended use and substantially complete and request ENGINEER to issue a certificate of Substantial Completion for that part of the Work. Within a reasonable time after either such request, OWNER, CONTRACTOR, and ENGINEER shall make an inspection of that part of the Work to determine its status of completion. If ENGINEER does not consider that part of the Work to be substantially complete, ENGINEER will notify OWNER and CONTRACTOR in writing giving the reasons therefor. If ENGINEER considers that part of the Work to be substantially complete, the provisions of paragraph 14.04 will apply with respect to certification of Substantial Completion of that part of the Work and the division of responsibility in respect thereof and access thereto.

2. No occupancy or separate operation of part of the Work may occur prior to compliance with the requirements of paragraph 5.10 regarding property insurance.

14.06 *Final Inspection*

A. Upon written notice from CONTRACTOR that the entire Work or an agreed portion thereof is complete, ENGINEER will promptly make a final inspection with OWNER and CONTRACTOR and will notify CONTRACTOR in writing of all particulars in which this inspection reveals that the Work is incomplete or defective. CONTRACTOR shall immediately take such measures as are necessary to complete such Work or remedy such deficiencies.

14.07 *Final Payment*

A. *Application for Payment*

1. After CONTRACTOR has, in the opinion of ENGINEER, satisfactorily completed all corrections identified during the final inspection and has delivered, in accordance with the Contract Documents, all maintenance and operating instructions, schedules, guarantees, Bonds, certificates or other evidence of insurance certificates of inspection, marked-up record documents (as provided in paragraph 6.12), and other documents, CONTRACTOR may make application for final payment following the procedure for progress payments.

2. The final Application for Payment shall be accompanied (except as previously delivered) by: (i) all documentation called for in the Contract Documents, including but not limited to the evidence of insurance required by subparagraph 5.04.B.7; (ii) consent of the surety, if any, to final payment; and (iii) complete and legally effective releases or waivers (satisfactory to OWNER) of all Lien rights arising out of or Liens filed in connection with the Work.

3. In lieu of the releases or waivers of Liens specified in paragraph 14.07.A.2 and as approved by OWNER, CONTRACTOR may furnish receipts or releases in full and an affidavit of CONTRACTOR that: (i) the releases and receipts include all labor, services, material, and equipment for which a Lien could be filed; and (ii) all payrolls, material and equipment bills, and other indebtedness connected with the Work for which OWNER or OWNER's property might in any way be responsible have been paid or otherwise satisfied. If any Subcontractor or Supplier fails to furnish such a release or receipt in full, CONTRACTOR may furnish a Bond or other collateral satisfactory to OWNER to indemnify OWNER against any Lien.

B. *Review of Application and Acceptance*

1. If, on the basis of ENGINEER's observation of the Work during construction and final inspection, and ENGINEER's review of the final

Application for Payment and accompanying documentation as required by the Contract Documents, ENGINEER is satisfied that the Work has been completed and CONTRACTOR's other obligations under the Contract Documents have been fulfilled, ENGINEER will, within ten days after receipt of the final Application for Payment, indicate in writing ENGINEER's recommendation of payment and present the Application for Payment to OWNER for payment. At the same time ENGINEER will also give written notice to OWNER and CONTRACTOR that the Work is acceptable subject to the provisions of paragraph 14.09. Otherwise, ENGINEER will return the Application for Payment to CONTRACTOR, indicating in writing the reasons for refusing to recommend final payment, in which case CONTRACTOR shall make the necessary corrections and resubmit the Application for Payment.

C. *Payment Becomes Due*

~~1. Thirty days after the presentation to OWNER of the Application for Payment and accompanying documentation, the amount recommended by ENGINEER will become due and, when due, will be paid by OWNER to CONTRACTOR.~~

14.08 Final Completion Delayed

A. If, through no fault of CONTRACTOR, final completion of the Work is significantly delayed, and if ENGINEER so confirms, OWNER shall, upon receipt of CONTRACTOR's final Application for Payment and recommendation of ENGINEER, and without terminating the Agreement, make payment of the balance due for that portion of the Work fully completed and accepted. If the remaining balance to be held by OWNER for Work not fully completed or corrected is less than the retainage stipulated in the Agreement, and if Bonds have been furnished as required in paragraph 5.01, the written consent of the surety to the payment of the balance due for that portion of the Work fully completed and accepted shall be submitted by CONTRACTOR to ENGINEER with the Application for such payment. Such payment shall be made under the terms and conditions governing final payment, except that it shall not constitute a waiver of Claims.

14.09 *Waiver of Claims*

A. The making and acceptance of final payment will constitute:

1. a waiver of all Claims by OWNER against CONTRACTOR, except Claims arising from unsettled Liens, from defective Work appearing after final inspection pursuant to paragraph 14.06, from failure to comply with the

Contract Documents or the terms of any special guarantees specified therein, or from CONTRACTOR's continuing obligations under the Contract Documents; and

2. a waiver of all Claims by CONTRACTOR against OWNER other than those previously made in writing which are still unsettled.

ARTICLE 15 - SUSPENSION OF WORK AND TERMINATION

15.01 OWNER May Suspend Work

A. At any time and without cause, OWNER may suspend the Work or any portion thereof for a period of not more than 90 consecutive days by notice in writing to CONTRACTOR and ENGINEER which will fix the date on which Work will be resumed. CONTRACTOR shall resume the Work on the date so fixed. ~~CONTRACTOR shall be allowed an adjustment in the Contract Price or an extension of the Contract Times, or both, directly attributable to any such suspension if CONTRACTOR makes a Claim therefor as provided in paragraph 10.05.~~

15.02 OWNER May Terminate for Cause

A. The occurrence of any one or more of the following events will justify termination for cause:

1. CONTRACTOR's persistent failure to perform the Work in accordance with the Contract Documents (including, but not limited to, failure to supply sufficient skilled workers or suitable materials or equipment or failure to adhere to the progress schedule established under paragraph 2.07 as adjusted from time to time pursuant to paragraph 6.04);

2. CONTRACTOR's disregard of Laws or Regulations of any public body having jurisdiction;

3. CONTRACTOR's disregard of the authority of ENGINEER; or

4. CONTRACTOR's violation in any substantial way of any provisions of the Contract Documents.

B. If one or more of the events identified in paragraph 15.02.A occur, OWNER may, after giving CONTRACTOR (and the surety, if any) seven days written notice, terminate the services of CONTRACTOR, exclude CONTRACTOR from the Site, and take possession of the Work and of all CONTRACTOR's tools, appliances, construction equipment, and machinery at the Site, and use the

same to the full extent they could be used by CONTRACTOR (without liability to CONTRACTOR for trespass or conversion), incorporate in the Work all materials and equipment stored at the Site or for which OWNER has paid CONTRACTOR but which are stored elsewhere, and finish the Work as OWNER may deem expedient. In such case, CONTRACTOR shall not be entitled to receive any further payment until the Work is finished. If the unpaid balance of the Contract Price exceeds all claims, costs, losses, and damages (including but not limited to all fees and charges of engineers, architects, attorneys, and other professionals and all court or arbitration or other dispute resolution costs) sustained by OWNER arising out of or relating to completing the Work, such excess will be paid to CONTRACTOR. If such claims, costs, losses, and damages exceed such unpaid balance, CONTRACTOR shall pay the difference to OWNER. Such claims, costs, losses, and damages incurred by OWNER will be reviewed by ENGINEER as to their reasonableness and, when so approved by ENGINEER, incorporated in a Change Order. When exercising any rights or remedies under this paragraph OWNER shall not be required to obtain the lowest price for the Work performed.

C. Where CONTRACTOR's services have been so terminated by OWNER, the termination will not affect any rights or remedies of OWNER against CONTRACTOR then existing or which may thereafter accrue. Any retention or payment of moneys due CONTRACTOR by OWNER will not release CONTRACTOR from liability.

15.03 OWNER May Terminate For Convenience

A. Upon seven days written notice to CONTRACTOR and ENGINEER, OWNER may, without cause and without prejudice to any other right or remedy of OWNER, elect to terminate the Contract. In such case, CONTRACTOR shall be paid (without duplication of any items):

1. for completed and acceptable Work executed in accordance with the Contract Documents prior to the effective date of termination, including fair and reasonable sums for overhead and profit on such Work;

2. for expenses sustained prior to the effective date of termination in performing services and furnishing labor, materials, or equipment as required by the Contract Documents in connection with uncompleted Work, plus fair and reasonable sums for overhead and profit on such expenses;

3. for all claims, costs, losses, and damages (including but not limited to all fees and charges of engineers, architects, attorneys, and other professionals and all court or

arbitration or other dispute resolution costs) incurred in settlement of terminated contracts with Subcontractors, Suppliers, and others; and

4. for reasonable expenses directly attributable to termination.

B. CONTRACTOR shall not be paid on account of loss of anticipated profits or revenue or other economic loss arising out of or resulting from such termination.

15.04 CONTRACTOR May Stop Work or Terminate

A. If, through no act or fault of CONTRACTOR, the Work is suspended for more than 90 consecutive days by OWNER or under an order of court or other public authority, or ENGINEER fails to act on any Application for Payment within 30 days after it is submitted, ~~or OWNER fails for 30 days to pay CONTRACTOR any sum finally determined to be due~~, then CONTRACTOR may, upon seven days written notice to OWNER and ENGINEER, and provided OWNER or ENGINEER do not remedy such suspension or failure within that time, terminate the Contract and recover from OWNER payment on the same terms as provided in paragraph 15.03. In lieu of terminating the Contract and without prejudice to any other right or remedy, if ENGINEER has failed to act on an Application for Payment within 30 days after it is submitted, ~~or OWNER has failed for 30 days to pay CONTRACTOR any sum finally determined to be due~~, CONTRACTOR may, seven days after written notice to OWNER and ENGINEER, stop the Work until payment is made of all such amounts due CONTRACTOR, including interest thereon. The provisions of this paragraph 15.04 are not intended to preclude CONTRACTOR from making a Claim under paragraph 10.05 for an adjustment in Contract Price or Contract Times or otherwise for expenses or damage directly attributable to CONTRACTOR's stopping the Work as permitted by this paragraph.

ARTICLE 16 - DISPUTE RESOLUTION

16.01 Methods and Procedures

A. Dispute resolution methods and procedures, if any, shall be as set forth in the Supplementary Conditions. If no method and procedure has been set forth, and subject to the provisions of paragraphs 9.09 and 10.05, OWNER and CONTRACTOR may exercise such rights or remedies as either may otherwise have under the Contract Documents or by Laws or Regulations in respect of any dispute.

ARTICLE 17 - MISCELLANEOUS

17.01 *Giving Notice*

A. Whenever any provision of the Contract Documents requires the giving of written notice, it will be deemed to have been validly given if delivered in person to the individual or to a member of the firm or to an officer of the corporation for whom it is intended, or if delivered at or sent by registered or certified mail, postage prepaid, to the last business address known to the giver of the notice.

17.02 *Computation of Times*

A. When any period of time is referred to in the Contract Documents by days, it will be computed to exclude the first and include the last day of such period. If the last day of any such period falls on a Saturday or Sunday or on a day made a legal holiday by the law of the applicable jurisdiction, such day will be omitted from the computation.

17.03 *Cumulative Remedies*

A. The duties and obligations imposed by these General Conditions and the rights and remedies available hereunder to the parties hereto are in addition to, and are not to be construed in any way as a limitation of, any rights and remedies available to any or all of them which are otherwise imposed or available by Laws or Regulations, by special warranty or guarantee, or by other provisions of the Contract Documents, and the provisions of this paragraph will be as effective as if repeated specifically in the Contract Documents in connection with each particular duty, obligation, right, and remedy to which they apply.

17.04 *Survival of Obligations*

A. All representations, indemnifications, warranties, and guarantees made in, required by, or given in accordance with the Contract Documents, as well as all continuing obligations indicated in the Contract Documents, will survive final payment, completion, and acceptance of the Work or termination or completion of the Agreement.

17.05 *Controlling Law*

A. This Contract is to be governed by the law of the state in which the Project is located.

**SECTION 00800 - SUPPLEMENTARY CONDITION TO THE
GENERAL CONDITIONS**

Table Of Contents

<u>Article Title</u>	<u>Page Number</u>
SC-1.00 Introduction	2
SC-1.01 Defined Terms	2
SC-1.02 Terminology	2
SC-2.05 Before Starting Construction	2
SC-2.06 Preconstruction Conference	2
SC-3.06 Coordination of Plans, Specifications, and Special Provisions	3
SC-4.02 Subsurface and Physical Conditions	4
SC-5.01 Performance, Payment and Other Bonds	4
SC-5.03 Certificates of Insurance	4
SC-5.04 CONTRACTOR's Liability Insurance.....	4
SC-5.05 OWNER's Liability Insurance	5
SC-5.06 Property Insurance	5
SC-5.07 Waiver of Rights	6
SC-5.08 Receipt and Application of Insurance Proceeds.....	6
SC-5.09 Acceptance of Bonds and Insurance; Option to Replace.....	6
SC-6.02 Labor; Working Hours.....	6
SC-6.08 Permits.....	7
SC-9.05 Authorized Variations in Work.....	7
SC-13.05 OWNER May Stop the Work	8
SC-13.07 Correction Period	8
SC-14.02 Progress Payments	9
SC-14.04 Substantial Completion.....	9
SC-14.07 Final Payment.....	10
SC-15.01 OWNER May Suspend Work	10
SC-15.02 OWNER May Terminate For Cause.....	10
SC-15.04 CONTRACTOR May Stop Work or Terminate	11
SC-16 Dispute Resolution	11
SC-16.02 Mediation.....	11
SC-17 Miscellaneous	11
SC-17.06 Liens	11

+++ END OF THIS SUPPLEMENTARY CONDITIONS INDEX +++

SECTION 00800 - SUPPLEMENTARY CONDITIONS TO THE GENERAL CONDITIONS

SC-1.00 Introduction

These Supplementary Conditions amend or supplement the Standard General Conditions of the Construction Contract (No. 1910-8, 1996 Edition) and other provisions of the Contract Documents as indicated below. All provisions, which are not so amended or supplemented, remain in full force and effect.

The terms used in these Supplementary Conditions will have the meanings indicated in the General Conditions.

SC-1.01 Defined Terms

SC-1.01.A.20 *Add the following language to the end of GC 1.01.A.20.*

OWNERS's Consultant: MBV Engineering, Inc.

SC-1.01.A.21. Delete paragraph GC 1.01.A.21 in its entirety.

SC-1.02 Terminology

SC-1.02.D.1, 2, and 3 *Delete paragraphs GC-1.02.D.1, 2, and 3 in their entirety and insert the following paragraphs in their place:*

D. *Furnish, Install, Perform, Provide*

1. The word "furnish" shall mean to supply and deliver services, materials, or equipment to the Site (or some other specified location) ready for use or installation and in usable or operable condition.
2. The word "install" shall mean to put into use or place in final position services, materials, or equipment complete and ready for intended use.
3. The words "perform" or "provide" shall mean to furnish and install services, materials, or equipment complete and ready for intended use.

SC-2.05 Before Starting Construction

SC-2.05.C. *Delete paragraph GC 2.05.C in its entirety and insert the following paragraph in its place:*

- C. Evidence of Insurance: CONTRACTOR shall not commence work under this Contract until he has obtained all insurance required under Article 5 and such insurance has been delivered to the OWNER and approved by the OWNER, nor shall the CONTRACTOR allow any Subcontractor to commence work on his subcontract until all similar insurance required of the Subcontractor has been so obtained and approved. All such insurance shall remain in effect until final payment and at all times thereafter when CONTRACTOR may be correcting, removing or replacing *defective* Work in accordance with Article 13.

SC-2.06 Preconstruction Conference

SC-2.06 *Delete paragraph GC-2.06.A in its entirety and insert the following paragraph in its place:*

- A. Immediately after awarding the contract, but before the CONTRACTOR begins work, the Project Manager will call a preconstruction conference at a place the OWNER

designates to establish an understanding among the parties as to the work and to discuss schedules referred to in paragraph 2.05.B, procedures for handling Shop Drawings and other submittals, and maintaining required records. Utility companies and others as appropriate will be requested to attend to discuss and coordinate work.

- B. Per the FDOT Standard Specifications for Road and Bridge Construction, the Contractor will certify to the Owner the following:
1. A listing of on-site clerical staff, supervisory personnel and their pro-rated time assigned to the contract,
 2. Actual Rate for items listed in Table 4-3.2.1 (see below),
 3. Existence of employee benefit plan for Holiday, Sick and Vacation benefits and a Retirement Plan, and,
 4. Payment of Per Diem is a company practice for instances when compensation for Per Diem is requested.

Such certification must be made by an officer or director of the Contractor with authority to bind the Contractor. Timely certification is a condition precedent to any right of the Contractor to recover compensations for such costs, and failure to timely submit the certification will constitute a full, complete, absolute and irrevocable waiver by the Contractor of any right to recover such costs. Any subsequent changes shall be certified to the Engineer as part of the cost proposal or seven calendar days in advance of performing such extra work.

FDOT Table 4-3.2.1	
Item	Rate
FICA	Rate established by Law
FUTA/SUTA	Rate established by Law
Medical Insurance	Actual
Holidays, Sick & Vacation Benefits	Actual
Retirement Benefits	Actual
Workers Compensation	Rates based on the National Council on Compensation Insurance basic rates tables adjusted by Contractor's actual experience modification factor in effect at the time of the additional work or unforeseen work
Per Diem	Actual but not to exceed State of Florida's rate
Insurance*	Actual
*Compensation for Insurance is limited solely to General Liability Coverage and does not include any other insurance coverage (such as, but not limited to, Umbrella Coverage, Automobile Insurance, etc.).	

SC-3.06 Coordination of Plans, Specifications, and Special Provisions

SC-3.06 Add the following new paragraphs immediately after paragraph GC-3.05:

SC-3.06 Coordination of Plans, Specifications, and Special Provisions

- A. In case of discrepancy, the governing order of the documents shall be as follows:
1. Written Interpretations
 2. Addenda
 3. Specifications
 4. Supplementary Conditions to the General Conditions
 5. General Conditions
 6. Approved Shop Drawings
 7. Drawings

8. Referenced Standards.
- B. Written/computed dimensions shall govern over scaled dimensions.

SC-4.02 Subsurface and Physical Conditions

SC-4.02 *Add the following new paragraphs immediately after paragraph GC-4.02.B:*

- C. In the preparation of Specifications, OWNER relied upon the following reports of explorations and tests of subsurface conditions at the Site: Correspondence from KSM (Appendix 4):
KSM Project #: 204419-p DATED 09/16/2020
KSM Project #: 204419-b DATED 09/16/2020
- D. Copies of correspondence itemized in SC-4.02.C are included with the Bidding Documents

SC-5.01 Performance, Payment and Other Bonds

SC-5.01.A. *Delete paragraph GC-5.01.A in its entirety and insert the following paragraphs in its place:*

Within fifteen (15) days of receipt of the Contract Documents for execution, the CONTRACTOR shall furnish a Public Construction Bond in an amount equal to 100% of the Contract Price.

1. In lieu of the Public Construction Bond, the CONTRACTOR may furnish an alternative form of security in the form of cash, money order, certified check, cashier's check, irrevocable letter of credit or a security as listed in Part II of F.S. Chapter 625. Any such alternative form of security shall be for the same purpose, and be for the same amount and subject to the same conditions as those applicable to the bond otherwise required. The determination of the value of an alternative form of security shall be made by the OWNER.
2. Such Bond shall continue in effect for one (1) year after acceptance of the Work by the OWNER.
3. The OWNER shall record the Public Construction Bond with the Public Record Section of the Indian River County Courthouse located at 2000 16th Avenue, Vero Beach, Florida 32960.

SC-5.03 Certificates of Insurance

SC-5.03 *Delete the second sentence of paragraph GC-5.03 in its entirety.*

SC-5.04 CONTRACTOR's Liability Insurance

SC-5.04 *Add the following new paragraphs immediately after paragraph GC-5.04.B:*

- C. The limits of liability for the insurance required by paragraph 5.04 of the General Conditions shall provide coverage for not less than the following amounts or greater where required by Laws and Regulations:
 1. General Liability Insurance providing all risk coverage in the amount of \$1,000,000 per occurrence and \$2,000,000 aggregate;
 2. Auto Liability coverage in the amount of \$1,000,000; and
 3. Workers Compensation insurance meeting statutory limits to include \$1,000,000 per accident and bodily injury by disease.
 4. Special Requirements:

- a. Ten (10) days prior to the commencement of any work under this Contract, certificates of insurance and endorsement forms in the exact wording and format as presented in these Contract Documents will be provided to the OWNER's Risk Manager for review and approval.
 - b. "Indian River County Florida" will be named as "Additional Insured" on both the General Liability and Auto Liability.
 - c. The OWNER will be given thirty (30) days notice prior to cancellation or modification of any stipulated insurance. Such notification will be in writing by registered mail, return receipt requested and addressed to the OWNER's Risk Manager.
 - d. An appropriate "Indemnification" clause shall be made a provision of the Contract (see paragraph 6.20 of the General Conditions).
 - e. It is the responsibility of the CONTRACTOR to insure that all subcontractors comply with all insurance requirements.
 - f. It should be remembered that these are minimum requirements, which are subject to modification in response to high hazard operation.
 - g. Insured must be authorized to do business and have an agent for service of process in Florida and have Best's Rating of A-VII or better.
- D. Additional Insureds:
- 1. In addition to "Indian River County, Florida," the following individuals or entities shall be listed as "additional insureds" on the CONTRACTOR's general liability and automobile insurance policies:
 - a. N/A

SC-5.05 OWNER's Liability Insurance

SC-5.05 *Delete paragraph GC-5.05.A in its entirety.*

SC-5.06 Property Insurance

SC-5.06 *Delete paragraphs GC-5.06.A, B, and C in their entirety and insert the following paragraphs in their place:*

- A. CONTRACTOR shall purchase and maintain property insurance upon the Work at the Site in the amount of the full replacement cost thereof. This insurance shall:
 - 1. include the interests of OWNER, CONTRACTOR, Subcontractors, ENGINEER, ENGINEER's Consultants and any other individuals or entities identified in the Supplementary Conditions, and the officers, directors, partners, employees, agents and other consultants and subcontractors of any of them each of whom is deemed to have an insurable interest and shall be listed as an insured or additional insured;
 - 2. be written on a Builder's Risk "All Risk" or open peril or special causes of loss policy form that shall at least include insurance for physical loss and damage to the Work, temporary buildings, falsework, and materials and equipment in transit and shall insure against at least the following perils or causes of loss: fire, lightning, extended coverage, theft, vandalism and malicious mischief, earthquake, flood, collapse, debris removal, demolition occasioned by enforcement of Laws and Regulations, water damage, and such other perils or causes of loss as may be specifically required by the Supplementary Conditions.
 - 3. include expenses incurred in the repair or replacement of any insured property (including but not limited to fees and charges of engineers and architects);

4. cover materials and equipment stored at the Site or at another location that was agreed to in writing by OWNER prior to being incorporated in the Work, provided that such materials and equipment have been included in an Application for Payment recommended by ENGINEER; and
5. allow for partial utilization of the Work by OWNER;
6. include testing and startup; and
7. be maintained in effect until final payment is made unless otherwise agreed to in writing by OWNER, CONTRACTOR and ENGINEER with 30 days written notice to each other additional insured to whom a certificate of insurance has been issued.

B. CONTRACTOR shall be responsible for any deductible or self-insured retention, without contribution from OWNER or its insurance carriers.

C. The policies of insurance required to be purchased and maintained by CONTRACTOR in accordance with this paragraph SC-5.06 shall comply with the requirements of paragraph 5.06.C of the General Conditions.

SC-5.06.E *Delete paragraph GC-5.06.E in its entirety and insert the following in its place:*

- E. Additional Insureds and Loss Payee:
1. The following individuals or entities shall be listed as “additional insureds” on the CONTRACTOR’s property insurance policies:
 - a. Indian River County, Florida
 2. Indian River County shall be listed as a loss payee on the Property Insurance policy.

SC-5.07 Waiver of Rights

SC-5.07 *Delete GC-5.07 (paragraphs A, B, and C) in its entirety.*

SC-5.08 Receipt and Application of Insurance Proceeds

SC-5.08 *Delete GC-5.08 (paragraphs A and B) in its entirety.*

SC-5.09 Acceptance of Bonds and Insurance; Option to Replace

SC-5.09 *Delete GC-5.09(paragraph A)in its entirety.*

SC-6.02 Labor; Working Hours

SC-6.02.B. *Add the following paragraphs immediately after paragraph GC-6.02.B:*

1. Regular working hours are defined as Monday through Friday, excluding Indian River County Holidays, from 7 a.m. to 5 p.m.
2. Indian River County Holidays are: New Year’s Day, Martin Luther King, Jr. Day, Good Friday, Memorial Day, Independence Day, Labor Day, Veterans Day, Thanksgiving Day, Friday after Thanksgiving, Christmas Eve and Christmas Day. Working on these days will not be permitted without prior written permission and approval from the Construction Coordination Manager.

3. The CONTRACTOR shall receive no additional compensation for overtime work, i.e., work in excess of eight hours in any one calendar day or 40 hours in any one calendar week, even though such overtime work may be required under emergency conditions and may be ordered by the ENGINEER in writing.
4. All costs of inspection and testing performed during overtime work by the CONTRACTOR, which is allowed solely for the convenience of the CONTRACTOR, shall be borne by the CONTRACTOR, and a credit given to the OWNER to deduct the costs of all such inspection and testing from any payments otherwise due the CONTRACTOR.
5. All costs of OWNER's employees and costs of ENGINEER's Consultant resulting from overtime work by the CONTRACTOR, which is allowed solely for the convenience of the CONTRACTOR, shall be borne by the CONTRACTOR, and a credit given to OWNER to deduct all such costs from any payments otherwise due the CONTRACTOR.
6. No work shall commence before 7 a.m. or continue after 5 p.m. except in case of emergency upon specific permission of the ENGINEER.

SC-6.06 Concerning Subcontractors, Suppliers, and Others

SC-6.06.C. *Add the following sentence at the end of paragraph GC-6.06.C:*

OWNER or ENGINEER may furnish to any such Subcontractor, Supplier, or other individual or entity, to the extent practicable, information about amounts paid to CONTRACTOR on account of Work performed for CONTRACTOR by a particular Subcontractor, Supplier, or other individual or entity.

SC-6.08 Permits

SC-6.08 *Add the following paragraphs immediately after paragraph GC-6.08.A:*

1. The CONTRACTOR shall obtain and pay for all other required permits and licenses. The CONTRACTOR shall provide copies of the permits to the OWNER and ENGINEER and shall comply with all conditions contained in the permits at no extra cost to the OWNER. A copy of the IRC Building Department Fee Schedule has been included as Appendix 5.
3. The CONTRACTOR shall be familiar with all permit requirements during construction and shall be responsible for complying with these requirements. The cost of this effort shall be included in the pay item in which the work is most closely associated with.

SC-9.05 Authorized Variations in Work

SC-9.05.A. *Delete the second sentence in paragraph GC-9.05.A in its entirety.*

SC-11.01 Cost of the Work

SC-11.01.A.1. *Delete paragraph GC-11.01.A.1 in its entirety, and insert the following sentences in its place:*

1. CONTRACTOR will receive payment for actual costs of direct labor and burden (see SC-2.06.B) for the additional or unforeseen work. Labor includes foremen actually engaged in the work; and will not include project supervisory personnel nor necessary on-site clerical staff, except when the additional or unforeseen work is a controlling work item and the performance of such controlling work item actually extends completion of the project due to no fault of the Contractor. Compensation for project supervisory personnel, but in no case higher than a Project Manager's position, shall only be for the pro-rata time such

supervisory personnel spent on the contract. In no case shall an officer or director of the Company, nor those persons who own more than 1% of the Company, be considered as project supervisory personnel, direct labor or foremen hereunder. The expenses of performing Work outside of regular working hours, on Saturday, Sunday, or legal holidays, shall be included in the above to the extent authorized by OWNER.

SC-13.03 Test and Inspections

SC-13.03.B. *Delete paragraph GC-13.03.B in its entirety, and insert the following sentences in its place:*

- B. OWNER shall employ and pay for the services of an independent testing laboratory to perform all initial inspections, tests, or approvals required by the Contract Documents except those inspections, tests, or approvals listed immediately below. Subsequent inspections, tests, or approvals required after initial failing inspections, tests, or approvals shall be paid for by the CONTRACTOR by back charge to subsequent applications for payment. The CONTRACTOR shall arrange, obtain, and pay for the following inspections, tests, or approvals:
1. inspections, tests, or approvals covered by paragraphs 13.03.C and 13.03.D below;
 2. costs incurred in connection with tests or inspections conducted pursuant to paragraph 13.04.B shall be paid as provided in said paragraph 13.04.B;
 3. tests otherwise specifically provided in the Contract Documents.

SC-13.05 OWNER May Stop the Work

SC-13.05.A. *Delete paragraph GC-13.05.A in its entirety and insert the following paragraph in its place:*

- A. If the Work is defective, or CONTRACTOR fails to supply sufficient skilled workers or suitable materials or equipment, or fails to comply with permit requirements, or fails to comply with the technical specifications, or fails to perform the Work in such a way that the completed Work will conform to the Contract Documents, OWNER may order CONTRACTOR to stop the Work, or any portion thereof, until the cause for such order has been eliminated; however, this right of OWNER to stop the Work shall not give rise to any duty on the part of OWNER to exercise this right for the benefit of CONTRACTOR, any Subcontractor, any Supplier, any other individual or entity, or any surety for, or employee or agent of any of them.

SC-13.07 Correction Period

SC-13.07.A. *Delete the first sentence of paragraph GC-13.07.A in its entirety and insert the following sentence in its place*

- A. If within one year after the date of Final Completion or such longer period of time as may be prescribed by Laws or Regulations or by the terms of any applicable special guarantee required by the Contract Documents or by any specific provision of the Contract Documents, any Work is found to be defective, or if the repair of any damages to the land or areas made available for CONTRACTOR's use by OWNER or permitted by Laws and Regulations as contemplated in paragraph 6.11.A is found to be defective, CONTRACTOR shall promptly, without cost to OWNER and in accordance with OWNER's written instructions: (i) repair such defective land or areas, or (ii) correct such defective Work or, if the defective Work has been rejected by OWNER, remove it from the Project and replace it with Work that is not defective, and (iii) satisfactorily correct or repair or remove and replace any damage to other Work, to the work of others or other land or areas resulting

therefrom.

SC-13.07 B. *Delete paragraph GC-13.07.B in its entirety and insert the following sentence in its place*

- B. In special circumstances where a particular item of equipment is placed in continuous service before Final Completion of all the Work, the correction period for that item may start to run from an earlier date if so provided in the Specifications or by Written Amendment.

SC-14.02 Progress Payments

SC-14.02.B.5. *Delete paragraph GC-14.02.B.5.d in its entirety and insert the following paragraph in its place:*

- d. ENGINEER has actual knowledge of the occurrence of any of the events enumerated in paragraph 15.02.A; or

SC-14.02.B.5. *Add the following sentences at the end of paragraph GC-14.02.B.5:*

- e. OWNER has been required to pay ENGINEER additional compensation because of CONTRACTOR delays or rejection of defective Work; or
- f. OWNER has been required to pay an independent testing laboratory for subsequent inspections, tests, or approvals taken after initial failing inspections, tests, or approvals.

SC-14.02.C.1. *Delete paragraph GC-14.02.C.1 in its entirety and insert the following paragraph in its place:*

- C. Payment Becomes Due
 1. Payment shall be made by OWNER to CONTRACTOR according to the Local Government Prompt Payment Act. F.S. 218.70 et. seq.

SC-14.04 Substantial Completion

SC-14.04A. *After the third sentence in paragraph GC-14.04A of the General Conditions, delete the remainder of paragraph 14.04A in its entirety and replace with the following:*

“If Engineer considers the Work substantially complete, Engineer will prepare and deliver to Owner a tentative certificate of Substantial Completion that shall fix the date of Substantial Completion. In accordance with the provisions of Florida Statutes section 208.735(7)(a)(2005), upon receipt of the tentative certificate of Substantial Completion from Engineer, the Owner, the Engineer, and the Contractor shall conduct a walk-through inspection of the Project to document a list of any items required to render the Work on the Project complete, satisfactory, and acceptable under this Agreement (herein the “Statutory List”). The Statutory List shall be reduced to writing and circulated among the Owner, the Engineer, and the Contractor by the Owner or the Engineer within 30 calendar days after substantial completion. The Owner and Contractor acknowledge and agree that: 1) the failure to include any corrective work, or pending items that are not yet completed, on the Statutory List does not alter the responsibility of the Contractor to complete all of the Work under this Agreement; 2) upon completion of all items on the Statutory List, the Contractor may submit a pay request for all remaining retainage except as otherwise set forth in this Agreement; and 3) any and all items that require correction

under this Agreement and that are identified after the preparation of the Statutory List remain the obligation of the Contractor to complete to the Owner's satisfaction under this Agreement. After receipt of the Statutory List by the Contractor, the Contractor acknowledges and agrees that it will diligently proceed to complete all items on the Statutory List and schedule a final walk-through in anticipation of final completion on the Project."

SC-14.04B *Add the following new paragraph immediately after paragraph GC 14.04B:*

C. At the time of delivery of the tentative certificate of Substantial Completion, Engineer will deliver to Owner and Contractor a written recommendation as to division of responsibilities pending final payment between Owner and Contractor with respect to security, operation, safety, and protection of the Work, maintenance, heat, utilities, insurance, and warranties and guarantees

SC-14.07 Final Payment

SC-14.07.C.1. *Delete paragraph GC-14.07.C.1 in its entirety and insert the following paragraph in its place:*

C. Payment Becomes Due

1. Payment shall be made by OWNER to CONTRACTOR according to the "Local Government Prompt Payment Act" , Florida Statutes section 218.70, et. seq.

SC-15.01 OWNER May Suspend Work

SC-15.01.A *Delete the last sentence in paragraph GC-15.01.A and insert the following in its place:*

CONTRACTOR shall be allowed an extension of the Contract Times, directly attributable to any such suspension if CONTRACTOR makes a Claim for an extension as provided in paragraph 10.05. CONTRACTOR shall not be allowed an adjustment of the Contract Price and CONTRACTOR shall not be paid on account of loss of anticipated profits or revenue or other economic loss arising out of or resulting from such Work suspension.

SC-15.02 OWNER May Terminate For Cause

SC-15.02.A.5 and SC-15.02.A.6 *Add the following new paragraphs immediately after paragraph GC-15.02.A.4:*

5. CONTRACTOR's violation of Section 02225 – "Erosion Control and Treatment of Dewatering Water From the Construction Site."
6. CONTRACTOR's failure to make payment to Subcontractors or Suppliers for materials or labor in accordance with the respective agreements between the CONTRACTOR and the Subcontractors or Suppliers.
7. CONTRACTOR certifies that it and its related entities as defined by Florida law are not on the Scrutinized Companies that Boycott Israel List, created pursuant to s. 215.4725 of the Florida Statutes, and are not engaged in a boycott of Israel. In addition, if this agreement is for goods or services of one million dollars or more, CONTRACTOR certifies that it and its related entities as defined above by Florida law are not on the Scrutinized Companies with Activities in Sudan List or the Scrutinized Companies with Activities in the Iran

Petroleum Energy Sector List, created pursuant to Section 215.473 of the Florida Statutes and are not engaged in business operations in Cuba or Syria.

OWNER may terminate this Contract if CONTRACTOR is found to have submitted a false certification as provided under section 287.135(5), Florida Statutes, been placed on the Scrutinized Companies with Activities in Sudan List or the Scrutinized Companies with Activities in the Iran Petroleum Energy Sector List, or been engaged in business operations in Cuba or Syria, as defined by section 287.135, Florida Statutes.

OWNER may terminate this Contract if CONTRACTOR, including all wholly owned subsidiaries, majority-owned subsidiaries, and parent companies, that exist for the purpose of making profit, is found to have been placed on the Scrutinized Companies that Boycott Israel List or is engaged in a boycott of Israel as set forth in section 215.4725, Florida Statutes.

SC-15.04 CONTRACTOR May Stop Work or Terminate

SC-15.04 *Delete the following text from the first sentence of paragraph GC-15.04.A:*

~~or OWNER fails for 30 days to pay CONTRACTOR any sum finally determined to be due,~~

SC-15.04 *Delete the following text from the second sentence of paragraph GC-15.04.A:*

~~or OWNER has failed for 30 days to pay CONTRACTOR any sum finally determined to be due,~~

SC-16 Dispute Resolution

SC-16.02 Mediation

SC-16 *Add the following new paragraph immediately after paragraph GC-16.01.*

SC-16.02 Mediation

- A. OWNER and CONTRACTOR agree that they shall submit any and all unsettled Claims or counterclaims, disputes, or other matters in question between them arising out of or relating to the Contract Documents or the breach thereof, to mediation by a certified mediator of the 19th Judicial Circuit in Indian River County unless delay in initiating mediation would irrevocably prejudice one of the parties. The mediator of any dispute submitted to mediation under this agreement shall not serve as arbitrator of such dispute unless otherwise agreed.

SC-17 Miscellaneous

SC-17.06 Liens

Add the following new paragraphs immediately after paragraph GC17.05:

SC-17.06 Liens

- A. This project is a "Public Works" under Chapter 255, Florida Statutes. No merchant's liens may be filed against the OWNER. Any claimant may apply to the OWNER for a copy of this Contract. The claimant shall have a right of action against the CONTRACTOR for the amount due him. Such action shall not involve the OWNER in any expense. Claims against

the CONTRACTOR are subject to timely prior notice to the CONTRACTOR as specified in Florida Statutes Section 255.05. The CONTRACTOR shall insert the following paragraph in all subcontracts hereunder:

“Notice: Claims for labor, materials and supplies are not assessable against Indian River County and are subject to proper prior notice to (CONTRACTOR’S Name) and to (CONTRACTOR Surety Company Name), pursuant to Chapter 255 of the Florida Statutes. This paragraph shall be inserted in every sub-subcontract hereunder.” The payment due under the Contract shall be paid by the OWNER to the CONTRACTOR only after the CONTRACTOR has furnished the OWNER with an affidavit stating that all persons, firms or corporations who are defined in Section 713.01, Florida Statutes, who have furnished labor or materials, employed directly or indirectly in the Work, have been paid in full. The OWNER may rely on said affidavit at face value. The CONTRACTOR does hereby release, remiss and quit-claim any and all rights he may enjoy perfecting any lien or any other type of statutory common law or equitable lien against the job.

++END OF SUPPLEMENTARY CONDITIONS++

SECTION 00942 - Change Order Form

No. ____

DATE OF ISSUANCE: _____

EFFECTIVE DATE: _____

OWNER: Indian River County
 CONTRACTOR _____
 Project: Hallstrom Farmstead Pavilions
 OWNER'S Bid No. 2022002
 FM No.: N/A

You are directed to make the following changes in the Contract Documents:
 Description:

Reason for Change Order:

Attachments: (List documents supporting change)

CHANGE IN CONTRACT PRICE:	
Description	Amount
Original Contract Price	\$ _____
Net Increase (Decrease) from previous Change Orders No. _____ to _____:	\$ _____
Contract Price prior to this Change Order:	\$ _____
Net increase (decrease) of this Change Order:	\$ _____
Contract Price with all approved Change Orders:	\$ _____

CHANGE IN CONTRACT TIMES	
Description	Time
Original Contract Time:	(days or dates) _____
Substantial Completion:	_____
Final Completion:	_____
Net change from previous Change Orders No. _____ to _____:	(days) _____
Substantial Completion:	_____
Final Completion:	_____
Contract Time prior to this Change Order:	(days or dates) _____
Substantial Completion:	_____
Final Completion:	_____
Net increase (decrease) this Change Order:	(days or dates) _____
Substantial Completion:	_____
Final Completion:	_____
Contract Time with all approved Change Orders:	(days or dates) _____
Substantial Completion:	_____
Final Completion:	_____

ACCEPTED:
By:
CONTRACTOR (Signature)
Date:

RECOMMENDED:
By:
ENGINEER (Signature)
Date:

APPROVED:
By:
OWNER (Signature)
Date:

SECTION 00948 - Work Change Directive

No. ____

DATE OF ISSUANCE: _____

EFFECTIVE DATE: _____

OWNER: Indian River County
 CONTRACTOR _____
 Project: Hallstrom Farmstead Pavilions
OWNER'S Bid No. 2022002
 FM No.: N/A

You are directed to proceed promptly with the following changes:

Description:

Reason for Change Order:

Attachments: (List documents supporting change)

If OWNER or CONTRACTOR believe that the above change has affected Contract Price any Claim for a Change Order based thereon will involve one or more of the following methods as defined in the Contract Documents.

Method of determining change in Contract Prices

- Unit Prices
- Lump Sum
- Other: _____
- By Change Order:

Estimated increase (decrease) of this Work Change Directive
 \$ _____

If the change involves an increase, the estimated amount is not to be exceeded without further authorization.

Method of determining change in Contract Times

- Contractor's Records
- Engineer's Records
- Other: _____
- By Change Order:

Estimated increase (decrease) in Contract Times:

Substantial Completion: _____ days;
 Ready for Final Completion: _____ days.

If the change involves an increase, the estimated time is not to be exceeded without further authorization.

ACCEPTED:
By:
CONTRACTOR (Signature)
Date:

RECOMMENDED:
By:
ENGINEER (Signature)
Date:

APPROVED:
By:
OWNER (Signature)
Date:

**** END OF SECTION ****

DIVISION 1 - GENERAL REQUIREMENTS

DIVISION 1 - GENERAL REQUIREMENTS

SECTION 01009 - SPECIAL PROVISIONS

SECTION 01024 - FORCE ACCOUNT

SECTION 01050 - FIELD ENGINEERING AND LAYOUT

SECTION 01091 - REFERENCE STANDARDS

SECTION 01215 - GENERAL QUALITY CONTROL

SECTION 01220 - PROGRESS MEETINGS

SECTION 01310 - CONSTRUCTION SCHEDULES

SECTION 01340 - SUBMITTAL OF SHOP DRAWINGS

SECTION 01520 - CONSTRUCTION FACILITIES AND TEMPORARY CONTROLS

SECTION 01541 - PROTECTION OF THE WORK AND PROPERTY

SECTION 01550 - ACCESS ROADS, PARKING AREAS AND USE OF PUBLIC STREETS

SECTION 01610 - TRANSPORTATION AND HANDLING OF MATERIALS AND EQUIPMENT

SECTION 01611 - STORAGE OF MATERIAL AND EQUIPMENT

SECTION 01630 - SUBSTITUTIONS

SECTION 01710 - SITE CLEANUP AND RESTORATION

SECTION 01820 - POST FINAL INSPECTION

SECTION 01009 - SPECIAL PROVISIONS

1.1 GENERAL

- A. Visits to the construction site may be made by representatives of permitting or governing bodies. Submit details of all instructions from the above to the ENGINEER immediately. The Work will not be accepted by the OWNER until final acceptance has been received from the various Regulatory Agencies having jurisdiction.
- B. Furnish sufficient labor, construction equipment and materials, and work such hours, including night shifts and overtime operations, as may be necessary to insure the prosecution of the work in accordance with the approved progress schedule. If, in the opinion of the ENGINEER, the CONTRACTOR falls behind the progress schedule, take such steps as may be necessary to improve progress, all without additional cost to the OWNER. The ENGINEER shall be compensated for his overtime services in accordance with the Supplementary Conditions, SC-6.02.
- C. All salvageable material and equipment for which specific use, relocation or other disposal is not specifically noted, shall remain the property of the OWNER and shall be delivered to the OWNER at the following location: 4550 41st Street, at the CONTRACTOR's expense. All material and equipment not in salvageable condition, as determined by the ENGINEER and the OWNER, shall be disposed of by the CONTRACTOR, at the CONTRACTOR's expense.
- D. In addition to these Specifications all work must comply with the requirements of the local governing agency, St. Johns River Water Management District, Department of Environmental Protection, Army Corps of Engineers, Indian River Farms Water Control District, and all other applicable State or Federal agencies' specifications and permits. In the event of a conflict, the more stringent specification or requirement shall govern.
- E. Before performing any work outside the designated limits of the work site, secure any necessary permits and authorization from the applicable owner, or verify in writing that such has been previously obtained. Follow all requirements of any said permits or authorization. Give the ENGINEER and appropriate owner ten (10) days minimum notice before commencing construction operations outside the designated limits of the work site.

+ + END OF SECTION + +

SECTION 01024 - FORCE ACCOUNT

1.1 GENERAL

- A. CONTRACTOR shall furnish all labor, materials, equipment and incidentals necessary to perform additional work not covered on the Contract Drawings. The force Account is intended as a contingency for unforeseen work.

1.2 PAYMENT

- A. Lump sum amount for force account work is included in the bid schedule. The value of force account work will be determined in accordance with Article 12 of the General Conditions.

+ + END OF SECTION + +

SECTION 01050 - FIELD ENGINEERING AND LAYOUT

1.1 GENERAL

- A. The CONTRACTOR will furnish all construction staking for the project. All staking from control will be under the supervision of a Florida Registered Land Surveyor.
- B. Develop and make all detail surveys and measurements needed for construction including but not limited to, slope stakes, batter boards, piling layouts and all other working lines, elevations and cut sheets.
- C. Provide all material required for benchmarks, control points, batter boards, grade stakes, and other items.
- D. Be solely responsible for all locations, dimensions and levels. No data other than written orders of the ENGINEER shall justify departure from the dimensions and levels required by the Drawings.
- E. Safeguard all points, stakes, grademarks, monuments and benchmarks made or established on the Work, and reestablish same, if disturbed. Rectify all Work improperly installed because of not maintaining, not protecting or removing without authorization such established points, stakes, marks and monuments.
- F. The cost of performing engineering and layout work described above shall be included in the contract unit prices for the various items of work to which it is incidental. No separate payment will be made for surveying or engineering.

1.2 SURVEY WORK AND QUALIFICATIONS OF SURVEYOR

- A. Prior to commencing work, the CONTRACTOR shall satisfy himself as to the accuracy of all survey and existing site information as indicated in the Contract Documents. Immediately notify the ENGINEER upon discovery of any errors, inaccuracies or omissions in the survey data. The commencing of any of the work by the CONTRACTOR shall be held as the CONTRACTOR's acceptance that all survey or existing site information is correct and accurate, without any reasonably inferable errors, inaccuracies or omissions.
- B. The CONTRACTOR shall carefully preserve all control stakes, benchmarks, reference points and property corners and will be responsible for any mistake or loss of time caused by their unnecessary loss or disturbance. If the loss or disturbance of the stakes or marks cause a delay in the Work, the CONTRACTOR shall have no claim for damages or extension of time. Control stakes, benchmarks, reference points and property corners disturbed by the CONTRACTOR's work shall be replaced by a Florida Registered Land Surveyor and Mapper, at the CONTRACTOR's expense. In the event the Owner must provide the services of the Florida Registered Surveyor and Mapper to perform this replacement work, the cost of the surveying services will be deducted from any sums due the CONTRACTOR for the work performed under this Contract.

- C. All survey work shall be performed under the guidance and direction of a Florida Registered Surveyor and Mapper.
- D. All survey work for Record Drawings shall be performed by a Florida Registered Surveyor and Mapper.

1.3 STATION BOARDS

- A. CONTRACTOR shall erect and maintain white/black standard FDOT station markers every 100 feet.

1.4 LAYOUT OF STRIPING

- A. Establish by instrument, and mark the finished surface, the points necessary for striping finished roadway in conformance with Section 5-7 of FDOT Standard Specifications.

+ + END OF SECTION + +

SECTION 01091 - REFERENCE STANDARDS**1.1 GENERAL**

- A. Whenever reference is made to the furnishing of materials or testing thereof to conform to the standards of any technical society, organization or body, it shall be construed to mean the latest standard, code, specification or tentative specification adopted and published at the date of advertisement for bids, unless noted otherwise in the Technical Specifications or on the Drawings. When a reference standard is specified, comply with requirements and recommendations stated in that standard, except when they are modified by the Contract Documents, or when applicable laws, ordinances, rules, regulations or codes establish stricter standards. The list of specifications presented in Paragraph B is hereby made a part of the Contract, the same as if repeated herein in full.
- B. Reference to a technical society, organization, or body may be made in the Specifications by abbreviations, in accordance with the following list:

AASHTO	The American Association of State Highway and Transportation Officials
ACI	American Concrete Institute
AGA	American Gas Association
AISC	American Institute of Steel Construction
AISI	American Iron and Steel Institute
ANSI	American National Standards Institute
ASCE	American Society of Civil Engineers
ASTM	American Society for Testing and Materials
AWPA	American Wood Preservers Association
AWWA	American Water Works Association
AWS	American Welding Society
FED.SPEC.	Federal Specifications
CRSI	Concrete Reinforcing Steel Institute
FDEP/DEP	Florida Department of Environmental Protection
DNR	Department of Natural Resources
NCPI	National Clay Pipe Institute
NEMA	National Electrical Manufacturers Association
NEC	National Electric Code
NSPE	National Society of Professional Engineers
OSHA	Occupational Safety and Health Administration

PCI	Prestressed Concrete Institute
FDOT/DOT	Florida Department of Transportation
U. L., Inc.	Underwriter's Laboratories, Inc.
SSPC	Steel Structures Painting Council
SJRWMD	St. Johns River Water Management District

- C. When no reference is made to a code, standard or specification, the standard specifications of ASTM, FDOT, or ANSI shall govern.
- D. In the event of a conflict between the specifications prepared by the ENGINEER and the above referenced specifications and standards, or any other regulatory specification or standard, the more stringent requirement prevails.

+ + END OF SECTION + +

SECTION 01215 - GENERAL QUALITY CONTROL

1.1 DESCRIPTION OF REQUIREMENTS

- A. Definitions: Specific quality control requirements for the work are indicated throughout the Contract Documents. The requirements of this section are primarily related to the performance of the work beyond the furnishing of manufactured products. The term "Quality Control" includes, but is not necessarily limited to, inspection and testing and associated requirements. This section does not specify or modify the OWNER and ENGINEER duties relating to quality review and Contract surveillance.

1.2 RESPONSIBILITY FOR INSPECTIONS AND TESTS

- A. Residual OWNER Responsibility: The OWNER will employ and pay for the services of independent testing laboratories to perform those required inspections and tests.
- B. CONTRACTORS General Responsibility: No failure of test agencies, whether engaged by the OWNER or CONTRACTOR, to perform adequate inspections of tests or to properly analyze or report results, shall relieve the CONTRACTOR of responsibility for the fulfillment of the requirements of the Contract Documents. It is recognized that the required inspection and testing program is intended to assist the CONTRACTOR, OWNER, ENGINEER, and governing authorities in the nominal determination of probable compliance with requirements for certain crucial elements of work. The program is not intended to limit the CONTRACTOR in his regular quality control program, as needed for general assurance of compliance.

1.3 QUALITY ASSURANCE

- A. General Workmanship Standards: It is a requirement that each category of tradesman or installer performing the work be pre-qualified, to the extent of being familiar with the applicable and recognized quality standards for his category of work, and being capable of workmanship complying with those standards.

1.4 PRODUCT DELIVERY-STORAGE-HANDLING

Handle, store and protect materials and products, including fabricated components, by methods and means which will prevent damage, deterioration and losses (and resulting delays), thereby ensuring highest quality results as the performance of the work progresses. Control delivery schedules so as to minimize unnecessary long-term storage at the project site prior to installation.

+ + END OF SECTION + +

SECTION 01220 - PROGRESS MEETINGS

1.1 SCOPE

- A. Date and Time:
 - 1. Regular Meetings: As mutually agreed upon by ENGINEER and CONTRACTOR.
 - 2. Other Meetings: On call.
- B. Place: Project site.

1.2 MINIMUM ATTENDANCE

- A. CONTRACTOR
- B. SUBCONTRACTOR:
When needed for the discussion of a particular agenda item, CONTRACTOR shall require representatives of Subcontractors or suppliers to attend a meeting.
- C. OWNER'S representative, if required.
- D. Others as appropriate.
- E. Representatives present for each party shall be authorized to act on their behalf.

1.3 AGENDA

Agenda will include, but will not necessarily be limited to, the following:

- 1. Transcript of previous meeting.
- 2. Progress since last meeting.
- 3. Planned progress for next period.
- 4. Problems, conflicts and observations.
- 5. Change Orders.
- 6. Status of Shop Drawings.
- 7. Quality standards and control.
- 8. Schedules, including off-site fabrication and delivery schedules. Corrective measures, if required.
- 9. Coordination between parties.
- 10. Safety concerns.
- 11. Other business.

+ + END OF SECTION + +

SECTION 01310 - CONSTRUCTION SCHEDULES

1.1 GENERAL REQUIREMENTS

- A. No partial payments shall be approved by the ENGINEER until there is an approved construction progress schedule on hand.
- B. Designate an authorized representative who shall be responsible for development and maintenance of the schedule and of all progress and payment reports. This representative shall have direct project control and complete authority to act on behalf of the CONTRACTOR in fulfilling the commitments of the CONTRACTOR's schedules.

1.2 REVISIONS TO THE CONSTRUCTION SCHEDULES

When the ENGINEER requires the CONTRACTOR to submit revised (updated) progress schedules on a monthly basis the CONTRACTOR shall:

- A. Indicate the progress of each activity to the date of submission.
- B. Show changes occurring since the previous submission listing:
 - 1. Major changes in scope.
 - 2. Activities modified since the previous submission.
 - 3. Revised projections of progress and completion.
 - 4. Other identifiable changes.
- C. Provide a narrative report as needed to define:
 - 1. Problem areas, anticipated delays, and the impact on the schedule.
 - 2. Corrective action recommended and its effect.
 - 3. The effect of changes on schedules of other prime contractors.

1.3 SUBMISSION OF THE CONSTRUCTION SCHEDULES

On or before the tenth day after the effective date of the Agreement, submit the initial schedules to the ENGINEER. If required by the ENGINEER, submit revised monthly progress schedules with that month's application for payment.

+ + END OF SECTION + +

SECTION 01340 - SUBMITTAL OF SHOP DRAWINGS

1.1 SCOPE

- A. Submit shop drawings, product data and samples as required by or inferred by the Drawings and Specifications. Submittals shall conform to the requirements of Article 6.17 of the General Conditions, Section 00700, and as described in this Section.

1.2 SHOP DRAWINGS

- A. Shop drawings are original drawings, prepared by the CONTRACTOR, a subcontractor, supplier, or distributor, which illustrate some portion of the work; showing fabrication, layout, setting, or erection details. Shop drawings are further defined in Article 6.17, Section 00700.
- B. Shop drawings shall be prepared by a qualified detailer and shall be identified by reference to sheet and detail numbers on the Contract Drawings.

1.3 PRODUCT DATA

- A. Product data are manufacturer's standard schematic drawings and manufacturer's catalog sheets, brochures, diagrams, schedules, performance charts, illustrations, and other standard descriptive data. Product data are further defined in Article 6.17, Section 00700.
- B. Modify standard drawings to delete information which is not applicable to the project and supplement them to provide additional information applicable to the project.
- C. Clearly mark catalog sheets, brochures, etc., to identify pertinent materials, products, or models.

1.4 SAMPLES

- A. Samples are physical examples to illustrate materials, equipment, or workmanship and to establish standards by which work is to be evaluated. Samples are further defined in Article 6.17, Section 00700.

1.5 CONTRACTOR'S RESPONSIBILITIES FOR SUBMITTAL OF SHOP DRAWINGS, PRODUCT DATA AND SAMPLES

- A. The CONTRACTOR's responsibilities for submittal of shop drawings, product data, and samples are set forth in paragraph 6.17 of the General Conditions and as further explained herein.
- B. Prior to submission, thoroughly check shop drawings, product data, and samples for completeness and for compliance with the Contract Documents, verify all dimensions and field conditions, and coordinate the shop drawings with the requirements for other related work. Also review each shop drawing before submitting it to the ENGINEER to determine that it is acceptable in terms of the means, methods, techniques, sequences and operations of construction, safety precautions and programs incidental thereto, all of which are the CONTRACTOR's responsibility.
 - 1. It is CONTRACTOR'S responsibility to review submittals made by his suppliers and Subcontractors before transmitting them to ENGINEER to assure proper coordination of the Work and to determine that each submittal is in accordance with its desires and that there is sufficient information about materials and equipment for ENGINEER to determine compliance with the Contract Documents.
 - 2. Incomplete or inadequate submittals will be returned for revision without review.
- C. The CONTRACTOR's responsibility for errors and omissions in submittals is not relieved by the ENGINEER's review of submittals. The CONTRACTOR shall approve the shop drawings based on his in-the-field measurements, prior to submittal to the ENGINEER for his review.
- D. Notify the ENGINEER, in writing at the time of submission, of deviations in submittals from the requirements of the Contract Documents. The CONTRACTOR's responsibility for deviations in submittals from the requirements of the Contract Documents is not relieved by the ENGINEER's review of submittals, unless the ENGINEER gives written acceptance of specific deviations.
- E. Begin no work, which requires submittals until return of submittals with the ENGINEER's stamp and initials or signature indicating the submittal has been reviewed.

1.6 SUBMITTAL REQUIREMENTS AND ENGINEER'S REVIEW FOR SHOP DRAWINGS, PRODUCT DATA AND SAMPLES

- A. Submit to:
 Indian River County
 Parks and Recreation
 5500 77th Street
 Vero Beach, FL 32967

- B. A letter of transmittal shall accompany each submittal. If data for more than one Section of the Specifications is submitted, a separate transmittal letter shall accompany the data submitted for each Section.

- C. At the beginning of each letter of transmittal, provide a reference heading indicating the following:
 - 1. OWNER'S Name
 - 2. Project Name
 - 3. Project Number
 - 4. Transmittal Number

- D. All submittals shall have a title block with complete identifying information satisfactory to the ENGINEER. The following is a sample Submittal Form that the CONTRACTOR may use:

[The remainder of this page has been left blank intentionally]

CONTRACTOR SUBMITTALS

SUBMITTAL NO.

Contractor:

Date Sent to County _____

No. Copies Sent to County _____

Original Submittal Re-Submittal

Project Name: **HALLSTROM FARMSTEAD PAVILIONS**

Project No.: **N/A**

Shop Drawing Cut Sheet Other _____

Description: _____

Sub-Contractor: _____

Remarks: _____

*

Reviewing Agency: (As checked below)

Date Received Date Returned No. Copies Ret'd

I R C Engineering Div. _____

I R C Utilities Services _____

Remarks: _____

*

IRC Parks and Recreation Department

Date Rec'd from Contractor

Date Ret'd to Contractor _____

5500 77th Street
Vero Beach, FL 32967

No. Copies Ret'd _____

Remarks: _____

Distribution of Copies:

IRC Parks and Recreation Department

Office File

- E. All submittals shall bear the stamp of approval and signature of CONTRACTOR as evidence that they have been reviewed by CONTRACTOR. Submittals without this stamp of approval will not be reviewed by the ENGINEER and will be returned to CONTRACTOR.
- F. Assign a number to each submittal starting with No. 1 and thence numbered consecutively. Identify resubmittals by the original submittal number followed by the suffix "A" for the first resubmittal, the suffix "B" for the second resubmittal, etc.
- G. Initially submit to ENGINEER a minimum of two (2) copies of all submittals that are on 11-inch by 17-inch or smaller sheets (no less than 8 1/2-inch x 11-inch).
- H. After ENGINEER completes his review, Shop Drawings will be marked with one of the following notations:
 - 1. Approved
 - 2. Approved as Noted
 - 3. NOT Approved - Resubmit
- I. If a submittal is acceptable, it will be marked "Approved" or "Approved as Noted". One (1) electronic copy of the submittal will be returned to CONTRACTOR.
- J. Upon return of a submittal marked "Approved" or "Approved as Noted", CONTRACTOR may order, ship or fabricate the materials included on the submittal, provided it is in accordance with the corrections indicated.
- K. If a submittal is unacceptable, one (1) copy will be returned to CONTRACTOR with following notation, "NOT Approved - Resubmit".
- L. Upon return of a submittal marked "NOT Approved - Resubmit", make the corrections indicated and repeat the initial approval procedure. Upon return of a submittal so marked, repeat the initial approval procedure utilizing acceptable material or equipment.
- M. Work shall not be performed nor equipment installed without an ENGINEER "Approved" or "Approved as Noted" Shop Drawing.
- N. Submit Shop Drawings well in advance of the need for the material or equipment for construction and with ample allowance for the time required to make delivery of material or equipment after data covering such is approved. CONTRACTOR shall assume the risk for all materials or equipment which is fabricated or delivered prior to the approval of Shop Drawings. Materials or equipment requiring Shop Drawings which have not yet received approval by the ENGINEER shall not be installed on the project. Materials or equipment will not be included in periodic progress payments until approval thereof has been obtained in the specified manner.

- P. ENGINEER will review and process all submittals promptly, but a reasonable time should be allowed for this, for the Shop Drawings being revised and resubmitted, and for time required to return the approved Shop Drawings to CONTRACTOR.

- Q. Furnish required submittals with complete information and accuracy in order to achieve required approval of an item within three submittals. All costs to ENGINEER involved with subsequent submittals of Shop Drawings, Samples or other items requiring approval, will be back-charged to CONTRACTOR in accordance with the General Conditions and the Supplementary Conditions. If the CONTRACTOR requests a substitution for a previously approved item, all of ENGINEER'S costs in the reviewing and approval of the substitution will be back-charged to CONTRACTOR unless the need for such substitution is beyond the control of CONTRACTOR.

++ END OF SECTION ++

SECTION 01520 - CONSTRUCTION FACILITIES AND TEMPORARY CONTROLS

1.1 SCOPE

- A. Provide all construction equipment and facilities and temporary controls required to satisfactorily complete the work represented on the Drawings and described in the Specifications.

1.2 RESPONSIBILITY

- A. All construction facilities and temporary controls remain the property of the Contractor establishing them and shall be maintained in a safe and useful condition until removed from the construction site.
- B. All false work, scaffolding, ladders, hoistways, braces, pumps, roadways, sheeting, forms, barricades, drains, flumes, and the like, any of which may be needed in construction of any part of the work and which are not herein described or specified in detail, must be furnished, maintained and removed by the CONTRACTOR, who is responsible for the safety and efficiency of such work and for any damage that may result from their failure or from their improper construction, maintenance or operation.
- C. In accepting the Contract, the CONTRACTOR assumes full responsibility for the sufficiency and safety of all hoists, cranes, temporary structures or work and for any damage which may result from their failure or their improper construction, maintenance or operation and will indemnify and save harmless the OWNER and ENGINEER from all claims, suits or actions and damages or costs of every description arising by reason of failure to comply with the above provision.

1.3 TEMPORARY UTILITIES AND SERVICES

A. TEMPORARY SANITARY FACILITIES

- 1. Provide temporary toilet facilities separate from the job office. Maintain these during the entire period of construction under this Contract for the use of all construction personnel on the job. Provide enough chemical toilets to conveniently serve the needs of all personnel. Properly seclude toilet facilities from public observation.
- 2. Chemical toilets and their maintenance shall meet the requirements of State and local health regulations and ordinances. Immediately correct any facilities or maintenance methods failing to meet these requirements. Upon completion of work, remove the facilities from the premises.

1.4 SECURITY

Full time watchmen will not be specifically required as a part of the Contract, but the CONTRACTOR shall provide inspection of work area and shall take whatever measures are

necessary to protect the safety of the public, workmen, and materials, and provide for the security of the site, both day and night.

1.5 TEMPORARY CONTROLS

Take all necessary precautions to control dust and mud associated with the work of this Contract. In dry weather, spray dusty areas daily with water in order to control dust. Take necessary steps to prevent the tracking of mud onto adjacent streets and highways.

1.6 REMOVAL OF TEMPORARY CONSTRUCTION FACILITIES

Remove the various temporary facilities, services, and controls and legally dispose of them as soon as the work is complete. The areas of the site used for temporary facilities shall be properly reconditioned and restored to a condition acceptable to the OWNER.

+ + END OF SECTION + +

SECTION 01541 - PROTECTION OF THE WORK AND PROPERTY

1.1 GENERAL

- A. CONTRACTOR shall be responsible for taking all precautions, providing all programs, and taking all actions necessary to protect the Work and all public and private property and facilities from damage as specified in the General Conditions and herein.
- B. In order to prevent damage, injury or loss, CONTRACTOR'S actions shall include, but not be limited to, the following:
 - 1. Store apparatus, materials, supplies, and equipment in an orderly, safe manner that will not unduly interfere with the progress of the Work or the Work of any other Contractor or utility service company.
 - 2. Provide suitable storage facilities for all materials, which are subject to injury by exposure to weather, theft, breakage, or otherwise.
 - 3. Place upon the Work or any part thereof, only such loads as are consistent with the safety of that portion of the Work.
 - 4. Clean up frequently all refuse, rubbish, scrap materials, and debris caused by construction operations, so that at all times, the site of the Work presents a safe, orderly, and workmanlike appearance.
 - 5. Provide barricades and guard rails around openings, for scaffolding, for temporary stairs and ramps, around excavations, elevated walkways and other hazardous areas.
- C. Except after written consent from proper parties, do not enter or occupy privately-owned land with men, tools, materials or equipment, except on easements provided herein.
- D. Assume full responsibility for the preservation of all public and private property or facility on or adjacent to the site. If any direct or indirect damage is done by or on account of any act, omission, neglect or misconduct in the execution of the Work by the CONTRACTOR, it shall be restored by the CONTRACTOR, at its expense, to a condition equal to or better than that existing before the damage was done.

1.2 TREE AND PLANT PROTECTION

- A. Protect existing trees, shrubs and plants on or adjacent to the site that are shown or designated to remain in place against unnecessary cutting, breaking or skinning of trunk, branches, bark or roots.
- B. Do not store or park materials or equipment within the drip line of trees that are to remain.
- C. Install temporary fences or barricades to protect trees and plants in areas subject to traffic.
- D. Fires shall not be permitted under or adjacent to trees and plants.

- E. Within the limits of the Work, water trees and plants that are to remain, in order to maintain their health during construction operations.
- F. Cover all exposed roots with burlap and keep it continuously wet. Cover all exposed roots with earth as soon as possible. Protect root systems from mechanical damage and damage by erosion, flooding, run-off or noxious materials in solution.
- G. If branches or trunks are damaged, prune branches immediately and protect the cut or damaged areas with emulsified asphalt compounded specifically for horticultural use.
- H. Remove all damaged trees and plants that die or suffer permanent injury and replace them with a specimen of equal or better quality.
- I. Coordinate Work in this Section with requirements of other sections herein.

1.3 PROTECTION OF EXISTING STRUCTURES

- A. Underground Structures:
 - 1. Underground structures are defined to include, but not be limited to, all sewer, water, gas, and other piping, and manholes, chambers, electrical conduits, tunnels and other existing subsurface work located within or adjacent to the limits of the Work.
 - 2. All underground structures known to ENGINEER except service connections for water, sewer, electric, and telephone are shown. This information is shown for the assistance of CONTRACTOR in accordance with the best information available, but is not guaranteed to be correct or complete. The existing utilities shown on the Contract Drawings are located according to the information available to the ENGINEER at the time the Drawings were prepared and have not been independently verified by the OWNER or the ENGINEER. Guarantee is not made that all existing underground utilities are shown or that the locations of those shown are accurate. The locations shown are for bidding purposes only. Finding the actual location of any existing utilities is the CONTRACTOR's responsibility and shall be done before it commences any work in the vicinity. Furthermore, the CONTRACTOR shall be fully responsible for any and all damages, which might be occasioned by the CONTRACTOR's failure to exactly locate and preserve any and all underground utilities. The OWNER or ENGINEER will assume no liability for any damages sustained or costs incurred because of the CONTRACTOR's operations in the vicinity of existing utilities or structures, nor for temporary bracing and shoring of same. If it is necessary to shore, brace, or swing a utility, contact the utility company or department affected and obtain their permission regarding the method to use for such work.
 - 3. Contact the various utility companies which may have buried or aerial utilities within or near the construction area before commencing work. Provide 48 hours minimum notice to all utility companies prior to beginning construction.

4. Explore ahead of trenching and excavation work and uncover all obstructing underground structures sufficiently to determine their location, to prevent damage to them and to prevent interruption of the services which such structures provide. If CONTRACTOR damages an underground structure, restore it to original condition at CONTRACTOR's expense.

5. Necessary changes in the location of the Work may be made by OWNER, to avoid unanticipated underground structures.

B. All other existing surface facilities, including but not limited to, guard rails, posts, guard cables, signs, poles, markers, and curbs which are temporarily removed to facilitate installation of the Work shall be replaced and restored to their original condition at CONTRACTOR'S expense.

1.6 DAMAGE TO EXISTING STRUCTURES AND UTILITIES

A. The CONTRACTOR shall be responsible for and make good all damage to pavement beyond the limits of this Contract, buildings, telephone or other cables, water pipes, sanitary pipes, or other structures which may be encountered, whether or not shown on the Drawings.

Information shown on the Drawings as to the location of existing utilities has been prepared from the most reliable data available to the Engineer. This information is not guaranteed, however, and it shall be this CONTRACTOR's responsibility to determine the location, character and depth of any existing utilities. He shall assist the utility companies, by every means possible to determine said locations. Extreme caution shall be exercised to eliminate any possibility of any damage to utilities resulting from his activities.

+ + END OF SECTION + +

SECTION 01550 - ACCESS ROADS, PARKING AREAS AND USE OF PUBLIC STREETS

1.1 GENERAL

- A. Provide all temporary construction roads, walks and parking areas required during construction and for use of emergency vehicles. Design and maintain temporary roads and parking areas so they are fully usable in all weather conditions.
- B. Prevent interference with traffic and the OWNER's operations on existing roads. Indemnify and save harmless the OWNER from any expenses caused by CONTRACTOR's operations over these roads.
- C. Roadways damaged by CONTRACTOR shall be restored to their original condition by the CONTRACTOR subject to approval of the OWNER or ENGINEER.
- D. Remove temporary roads, walks and parking areas prior to final acceptance and return the ground to its original condition, unless otherwise required by the Contract Documents.

1.2 USE OF PUBLIC STREETS

The use of public streets and alleys shall be such as to provide a minimum of inconvenience to the public and to other traffic. Any earth or other excavated material spilled from trucks shall be removed immediately by the CONTRACTOR and the streets cleaned to the satisfaction of the Owner.

1.3 USE OF PUBLIC STREETS FOR HAUL ROADS

- A. Prior to construction, the CONTRACTOR shall designate all proposed haul roads to be used during the life of the project. Any earth or other materials spilled from trucks shall be removed by the CONTRACTOR and streets cleaned to the satisfaction of the Owner. He further shall be responsible for repairs to any damages caused by his operations, prior to final payment.
- B. All trucks carrying earth shall be covered while moving with an appropriate tarpaulin. Should trucks hauling earth fail to cover their loads, the CONTRACTOR will be given two (2) written warnings, after which the CONTRACTOR shall pay a fine of \$50 per uncovered truck to the Owner when invoked by the Owner to Owner's Engineer. All cleanup shall be the responsibility of the CONTRACTOR.
- C. All trucks/moving equipment shall have backup warning horns in proper working order while on the job site.

++ END OF SECTION ++

SECTION 01610 - TRANSPORTATION AND HANDLING OF MATERIALS AND EQUIPMENT

1.1 GENERAL

- A. Make all arrangements for transportation, delivery and handling of equipment and materials required for prosecution and completion of the Work.
- B. Shipments of materials to CONTRACTOR or Subcontractors shall be delivered to the site only during regular working hours. Shipments shall be addressed and consigned to the proper party giving name of Project, street number and city. Shipments shall not be delivered to OWNER except where otherwise directed.
- C. If necessary, to move stored materials and equipment during construction, CONTRACTOR shall move or cause to be moved materials and equipment without any additional compensation.

1.2 DELIVERY

- A. Arrange deliveries of products in accord with construction schedules and in ample time to facilitate inspection prior to installation.
- B. Coordinate deliveries to avoid conflict with Work and conditions at site and to accommodate the following:
 - 1. Work of other contractors, or OWNER.
 - 2. Limitations of storage space.
 - 3. Availability of equipment and personnel for handling products.
 - 4. OWNER'S use of premises.
- C. Do not have products delivered to project site until related Shop Drawings have been approved by the ENGINEER.
- D. Do not have products delivered to site until required storage facilities have been provided.
- E. Have products delivered to site in manufacturer's original, unopened, labeled containers. Keep ENGINEER informed of delivery of all equipment to be incorporated in the Work.
- F. Partial deliveries of component parts of equipment shall be clearly marked to identify the equipment, to permit easy accumulation of parts, and to facilitate assembly.
- G. Immediately on delivery, Contractor shall inspect shipment to assure:
 - 1. Product complies with requirements of Contract Documents and reviewed submittals.
 - 2. Quantities are correct.
 - 3. Containers and packages are intact, labels are legible.
 - 4. Products are properly protected and undamaged.

1.3 PRODUCT HANDLING

- A. Provide equipment and personnel necessary to handle products, including those provided by OWNER, by methods to prevent soiling or damage to products or packaging.
- B. Provide additional protection during handling as necessary to prevent scraping, marring or otherwise damaging products or surrounding surfaces.
- C. Handle products by methods to prevent bending or overstressing.
- D. Lift heavy components only at designated lifting points.
- E. Materials and equipment shall at all times be handled in a safe manner and as recommended by manufacturer or supplier so that no damage will occur to them. Do not drop, roll or skid products off delivery vehicles. Hand carry or use suitable materials handling equipment.

+ + END OF SECTION + +

SECTION 01611 - STORAGE OF MATERIAL AND EQUIPMENT

1.1 GENERAL

- A. Store and protect materials and equipment in accordance with manufacturer's recommendations and requirements of Specifications.
- B. Make all arrangements and provisions necessary for the storage of materials and equipment. Place all excavated materials, construction equipment, and materials and equipment to be incorporated into the Work, so as not to injure any part of the Work or existing facilities, and so that free access can be had at all times to all parts of the Work and to all public utility installations in the vicinity of the Work. Keep materials and equipment neatly and compactly stored in locations that will cause a minimum of inconvenience to other contractors, public travel, adjoining owners, tenants and occupants. Arrange storage in a manner to provide easy access for inspection.
- C. Areas available on the construction site for storage of material and equipment shall be as shown or approved by the ENGINEER.
- D. Store materials and equipment which are to become the property of the OWNER to facilitate their inspection and insure preservation of the quality and fitness of the Work, including proper protection against damage by extreme temperatures and moisture.
- E. Do not use lawns, grass plots or other private property for storage purposes without written permission of the OWNER or other person in possession or control of such premises.
- F. CONTRACTOR shall be fully responsible for loss or damage to stored materials and equipment.
- G. Do not open manufacturers containers until time of installation unless recommended by the manufacturer or otherwise specified.
- H. When appropriate store materials on wood blocking so there is no contact with the ground.

++ END OF SECTION ++

SECTION 01630 - SUBSTITUTIONS

1.1 GENERAL

- A. Requests for review of a substitution shall conform to the requirements of Article 6.05, "Substitutes and Or-Equals," of the General Conditions, and shall contain complete data substantiating compliance of the proposed substitution with the Contract Documents.

1.2 CONTRACTOR'S OPTIONS

- A. For materials or equipment (hereinafter products) specified only by reference standard, select product meeting that standard by any manufacturer, fabricator, supplier or distributor (hereinafter manufacturer). To the maximum extent possible, provide products of the same generic kind from a single source.
- B. For products specified by naming several products or manufacturers, select any one of the products or manufacturers named which complies with Specifications.
- C. For products specified by naming one or more products or manufacturers and stating "or equivalent," submit a request for a substitution for any product or manufacturer which is not specifically named.
- D. For products specified by naming only one product or manufacturer and followed by words indicating that no substitution is permitted, there is no option and no substitution will be allowed.
- E. Where more than one choice is available as a CONTRACTOR's option, select product which is compatible with other products already selected or specified.

1.3 SUBSTITUTIONS

- A. During a period of 15 days after date of commencement of Contract Time, ENGINEER will consider written requests from CONTRACTOR for substitution of products or manufacturers, and construction methods (if specified).
 - 1. After end of specified period, requests will be considered only in case of unavailability of product or other conditions beyond control of CONTRACTOR.
- B. Submit 5 copies of Request for Substitution. Submit a separate request for each substitution. In addition to requirements set forth in Article 6.05 of General Conditions, include in the request the following:
 - 1. For products or manufacturers:
 - a. Product identification, including manufacturer's name and address.
 - b. Manufacturer's literature with product description, performance and test data, and reference standards.
 - c. Samples, if appropriate.

- d. Name and address of similar projects on which product was used, and date of installation.
 2. For construction methods (if specified):
 - a. Detailed description of proposed method.
 - b. Drawings illustrating method.
 3. Such other data as the ENGINEER may require to establish that the proposed substitution is equal to the product, manufacturer or method specified.
- C. In making Request for Substitution, CONTRACTOR represents that:
1. CONTRACTOR has investigated proposed substitution, and determined that it is equal to or superior in all respects to the product, manufacturer or method specified.
 2. CONTRACTOR will provide the same or better guarantees or warranties for proposed substitution as for product, manufacturer, or method specified.
 3. CONTRACTOR waives all claims for additional costs or extension of time related to a proposed substitution that subsequently may become apparent.
- D. A proposed substitution will not be accepted if:
1. Acceptance will require changes in the design concept or a substantial revision of the Contract Documents.
 2. It will delay completion of the Work, or the work of other contractors.
 3. It is indicated or implied on a Shop Drawing and is not accompanied by a formal Request for Substitution from CONTRACTOR.
- E. If the ENGINEER determines that a proposed substitute is not equal to that specified, furnish the product, manufacturer, or method specified at no additional cost to OWNER.
- F. Approval of a substitution will not relieve CONTRACTOR from the requirement for submission of Shop Drawings as set forth in the Contract Documents.
- G. The procedure for review by Engineer will include the following:
1. Requests for review of substitute items of material and equipment will not be accepted by Engineer from anyone other than CONTRACTOR.
 2. Upon receipt of an application for review of a substitution, Engineer will determine whether the review will be more extensive than a normal shop drawing review for the specified item.
 3. If the substitution will not require a more extensive review, Engineer will proceed with the review without additional cost to CONTRACTOR.
 4. If the substitution requires a more extensive review, Engineer will proceed with the review only after CONTRACTOR has agreed to reimburse Owner for the review cost.
 5. Engineer may require CONTRACTOR to furnish at CONTRACTOR's expense additional data about the proposed substitute.

- H. Any redesign of structural members shall be performed by, and the plans signed and sealed by, a Professional Engineer registered in the State of Florida. The redesign shall be at the CONTRACTOR's expense. Any redesign will require an extensive review by the Engineer. The CONTRACTOR must agree to reimburse the Owner for the review cost prior to the Owner's Engineer proceeding with the design review. The ENGINEER's estimated cost of review shall be provided to the CONTRACTOR prior to proceeding with the review to allow the CONTRACTOR the opportunity to rescind the request.
- I. Engineer will be allowed a reasonable time within which to evaluate each proposed substitution. Engineer will be the sole judge of acceptability and shall have the right to deny use of any proposed substitution. The CONTRACTOR shall not order, install, or utilize any substitution without either an executed Change Order or Engineer's notation on the reviewed shop drawing. Owner may require CONTRACTOR to furnish at CONTRACTOR's expense a special manufacturer's performance guarantee(s) or other surety with respect to any substitute and an indemnification by the CONTRACTOR. ENGINEER will record time required by Engineer and Engineer's consultants in evaluating substitutions proposed by CONTRACTOR and in making changes in the Contract Documents occasioned thereby. Whether or not a proposed substitute is used, CONTRACTOR shall reimburse Owner for the charges of Engineer and Engineer's consultants for evaluating each proposed substitute.
- J. Substitute materials or equipment may be proposed for acceptance in accordance with this Section. In the event that substitute materials or equipment are used and are less costly than the originally specified material or equipment, than the net difference in cost shall benefit the Owner and CONTRACTOR in equal proportions. This cost difference shall not be reduced by any failure of the CONTRACTOR to base his bid on the named materials or equipment.

+ + END OF SECTION + +

SECTION 01710 - SITE CLEANUP AND RESTORATION

1.1 SCOPE

Furnish all labor, equipment, appliances, and materials required or necessary to clean up and restore the site after the construction is completed.

1.2 REQUIREMENTS

- A. During the progress of the project, keep the work and the adjacent areas affected thereby in a neat and orderly condition. Remove all rubbish, surplus materials, and unused construction equipment. Repair all damage so that the public and property owners will be inconvenienced as little as possible.
- B. Provide onsite containers for the collection of waste materials, debris, and rubbish and empty such containers in a legal manner when they become full.
- C. Where material or debris has been deposited in watercourses, ditches, gutters, drains, or catch-basins as a result of the CONTRACTOR's operations, such material or debris shall be entirely removed and satisfactorily disposed of during the progress of the work, and the ditches, channels, drains, etc., shall be kept clean and open at all times.
- D. Before the completion of the project, unless otherwise especially directed or permitted in writing:
 - 1. Tear down and remove all temporary buildings and structures;
 - 2. Remove all temporary works, tools, and machinery, or other construction equipment furnished;
 - 3. Remove all rubbish from any grounds occupied; and
 - 4. Leave the roads, all parts of the premises, and adjacent property affected by construction operations, in a neat and satisfactory condition.
- E. Restore or replace any public or private property damaged by construction work, equipment, or employees, to a condition at least equal to that existing immediately prior to the beginning of the operations. To this end, the CONTRACTOR shall restore all highway, roadside, and landscaping work within any right-of-way, platted or prescriptive. Acceptable materials, equipment, and methods shall be used for such restoration.
- F. Thoroughly clean all materials and equipment installed and on completion of the work, deliver the facilities undamaged and in fresh and new-appearing condition.
- G. It is the intent of the Specifications to place the responsibility on the CONTRACTOR to restore to their original condition all items disturbed, destroyed, or damaged during construction. Particular attention will be placed on restoration of canals to equal or better condition than prior to construction.

- H. When finished surfaces require cleaning with cleaning materials, use only those cleaning materials which will not create hazards to health or property and which will not damage the surfaces. Use cleaning materials only on those surfaces recommended by the manufacturer. Follow the manufacturer's directions and recommendations at all times.
- I. Keep the amount of dust produced during construction activities to a minimum. At CONTRACTOR's expense, spray water or other dust control agents over the areas, which are producing the dust. Schedule construction operations so that dust and other contaminants will not fall on wet or newly coated surfaces.

1.3 SITE CLEANUP AND RESTORATION

Prior to final completion, the OWNER, ENGINEER, and CONTRACTOR shall review the site with regards to site cleanup and restoration. Clean and/or restore all items determined to be unsatisfactory by the OWNER or ENGINEER, at no additional expense.

+ + END OF SECTION + +

SECTION 01820 - POST FINAL INSPECTION

1.1 GENERAL

- A. Approximately one year after Final Completion, the OWNER will make arrangements with the Construction Coordination Manager and the CONTRACTOR for a post final inspection and will send a written notice to said parties to inform them of the date and time of the inspection.
- B. Corrections of defective work noted by OWNER and Construction Coordination Manager shall comply with the applicable sections of Article 13, General Conditions.
- C. After the inspection, the OWNER will inform the CONTRACTOR of any corrections required to release the performance and payment bonds.

+ + END OF SECTION + +

DIVISION 2 - TECHNICAL PROVISIONS

Table of Contents

SECTION 001 - TECHNICAL SPECIFICATIONS 2
SECTION 004 - SCOPE OF WORK..... 2
SECTION 101 - MOBILIZATION 3
SECTION 102 - MAINTENANCE OF TRAFFIC 3
SECTION 104 - PREVENTION, CONTROL, AND ABATEMENT OF EROSION AND WATER POLLUTION 5
SECTION 110 - CLEARING AND GRUBBING 16
SECTION 570 - PERFORMANCE TURF 17
SECTION 999 - RECORDS/AS-BUILTS 19

- APPENDIX 1 - SITE MAPS & PROJECT PLANS**
- APPENDIX 2 - RCP PAVILION SPECIFICATIONS**
- APPENDIX 3 - FDEP LAND & WATER CONSERVATION FUND GRANT AGREEMENT**
- APPENDIX 4 - Subsurface Soil Exploration and Geotechnical Engineering Evaluation**
- APPENDIX 5 - IRC BUILDING DEPARTMENT FEE SCHEDULE**
- APPENDIX 6 - INDIAN RIVER COUNTY TRAFFIC SPECIAL CONDITIONS FOR RIGHT OF WAY CONSTRUCTION**
- APPENDIX 7 - INDIAN RIVER COUNTY FERTILIZER ORDINANCE**

SECTION 001 - TECHNICAL SPECIFICATIONS

STANDARD SPECIFICATIONS

- A. All work of this Contract shall conform to the applicable technical specifications of Florida Department of Transportation Standard Specifications for Road and Bridge Construction, January 2012, and Supplemental Specification, Special Provisions and addenda thereto, except as modified and supplemented hereinafter. Reference to Article numbers herein-after apply to the FDOT Standard Specifications, and reference in FDOT Standard Specifications to Department shall be taken as the Owner or its appointed Representative. Wherever the Specifications, Supplementals, etc. may refer to the "Owner", "Department", "State of Florida Department of Transportation", or words relating to offices of State Government, such words shall be taken as meaning Owner or Indian River County, Florida. Wherever the word "Owner's Engineer", "District Engineer", "Engineer", "Project Engineer", etc., appears, it shall be taken to mean the Registered Professional Project Engineer of the Indian River County Public Works Department, Engineering Division acting directly or through duly authorized representatives. Wherever the word "Resident Engineer" appears, it shall be taken to mean an authorized representative of the Owner's Engineer on the Project (Resident Construction Inspector) who will act as an agent for Indian River County, assigned to observe the progress quantity and quality of the work.

The work to be performed for utility work (if any) shall conform to the applicable technical specifications of the "Indian River County Department of Utility Services, Water, Wastewater, and Reclaimed Water Utility Construction Standards" March, 2018 or the current version.

The work to be performed per line items 700 through 711 shall conform to the applicable standards of Indian River County Typical Drawings for Pavement Markings, Signing & Geometrics Revised March 2012.

SECTION 004 - SCOPE OF WORK

Section 4-3.9 Value Engineering Incentive is deleted in its entirety.

Indian River County has been awarded a Land and Water Conservation Fund (LWCF) Grant to construct public access improvements at the Hallstrom Farmstead Conservation Area located at 1273 Old Dixie Highway, Vero Beach, FL 32960 (refer to Appendix 1 for Project Maps). These improvements include parking, restrooms, trails, boardwalks, and picnic pavilions. The deadline for completing the improvement is April 30, 2022.

This Scope of Work includes the installation of the two picnic pavilions which are depicted on the Conceptual Plan included in Appendix 1. Proposed work includes installation of two pavilions: (1) 30' by 30' pavilion with a concrete floor and (1) 24' by 24' pavilion with a stabilized pervious floor. An Add/Alternate option is requested for stabilized pervious floor in the 30' x 30' pavilion.

Work will include permitting, any required survey, any required earthwork, construction of the two

pavilions; and any follow up materials and procedures required to complete the permitting and close-out the project. The County has provided specifications for a 30' by 30' shelter (refer to Appendix 2). The Contractor may elect to construct the pavilion per the manufacturer, or may elect to provide the County with plans and specifications for an equivalent structure. The construction of the 24' by 24' shelter will follow these specifications with respect to materials and methods of construction.

The site has been disturbed by past agricultural operations. The location(s) for the two pavilions are depicted on the maps provided within Appendix 1. Based on the project schedule, the selected Contractor may be required to coordinate mobilization and work schedule with other contractors working on the site. The Contractor will provide the County with a proposed schedule of work prior to the issuance of a Notice to Proceed. All work must be completed by April 30, 2022, including a request for final payment.

The Land and Water Conservation Grant which was awarded for the project (including pavilions, parking, restrooms, trails, and other amenities) has been included in Appendix 3. The Contractor will be required to maintain compliance with all provisions in this Grant. Federal requirements, as detailed in Attachments 4 and 5 of the Grant Award document, shall be completed by the Contractor.

SECTION 101 - MOBILIZATION

The work specified in this section shall conform to Section 101 of the Florida Department of Transportation Standard Specifications for Road and Bridge Construction.

- A. The Contractor shall maintain all grassed and landscaped areas within the project limits in a satisfactory condition until final acceptance of the project. Such maintenance within the limits of construction shall include the mowing of all existing grassed areas within the Right-of-Way, removal of all trash and debris on a weekly basis, and keeping vegetation trimmed on all sidewalks. Grass height shall not exceed 6" without mowing. Clippings shall be removed from sidewalk.

Item of Payment

Payment for the work specified in this item shall be made under:

Bid Item No. 101-1 – Mobilization/ Demobilization – Per Lump Sum

SECTION 102 - MAINTENANCE OF TRAFFIC

The work specified in this item shall conform to Section 102 of the Florida Department of Transportation Standard Specifications for Road and Bridge Construction, except as modified herein.

- A. **GENERAL PROVISIONS-DESCRIPTION:** The work specified in this Section consists of maintaining traffic within the limits of the project for the duration of the construction period,

including any temporary suspensions of the work. It shall include the construction and maintenance of any necessary detour facilities; the providing of necessary facilities for access to residences, businesses, etc., along the project; the furnishing, installing and maintaining of traffic control and safety devices during construction, the control of dust through the use of calcium chloride if necessary, and any other special requirements for safe and expeditious movement of traffic as may be called for on the plans. The term, Maintenance of Traffic, as used herein, shall include all of such facilities, devices and operations as are required for the safety and convenience of the public as well as for minimizing public nuisance; all as specified in this Itemized Section 14 of these provisions and Paragraph 24 in General Conditions Section.

- B. BEGINNING DATE OF CONTRACTOR'S RESPONSIBILITY: The Contractor shall present his Maintenance of Traffic Plan at or before the pre-construction conference. The Maintenance of Traffic Plan shall indicate the type and location of all signs, lights, barricades, striping and barriers to be used for the safe passage of pedestrians and vehicular traffic through the project and for the protection of the workmen. The plan will indicate conditions and setups for each phase of the Contractor's activities.

When the project plans include or specify a specific Maintenance of Traffic Plan, alternate proposals will be considered when they are found to be equal to or better than the plan specified.

In no case may the Contractor begin work until the Maintenance of Traffic Plan has been approved in writing by the Engineer. Modifications to the Maintenance of Traffic Plan that become necessary shall also be approved in writing. Except in an emergency, no changes to the approved plan will be allowed until approval to change such plan has been received.

The cost of all work included in the Maintenance of Traffic Plan shall be included in the pay item for Maintenance of Traffic.

The Contractor shall be responsible for performing daily inspections, including weekends and holidays, with some inspections at nighttime, of the installations on the project and replace all equipment and devices not conforming with the approved standards during that inspection. The project personnel will be advised of the schedule of these inspections and be given the opportunity to join in the inspection as is deemed necessary.

- C. TRAFFIC CONTROL - STANDARDS: The FDOT Design Standards For Design, Construction, Maintenance and Utility Operations On The State Highway System, Edition as dated on the plans set forth the basic principles and prescribes minimum standards to be followed in the design, application, installation, maintenance and removal of all traffic control devices and all warning devices and barriers which are necessary to protect the public and workmen from hazards within the project limits. The standards established in the aforementioned manual constitute the minimum requirements for normal conditions, and additional traffic control devices warning devices, barriers or other safety devices will be required where unusual, complex or particularly hazardous conditions exist.

The above referenced standards were developed using F.H.W.A., U.S.D.O.T. Manual on Uniform Traffic Control Devices (MUTCD).

- D. TRAFFIC CONTROL DEVICES, WARNING DEVICES AND BARRIERS - INSTALLATION: The responsibility for installation and maintenance of adequate traffic control devices, warning devices and barriers, for the protection of the travel in public and workmen, as well as to safeguard the work area in general shall rest with the Contractor. Consideration shall be given to recommendations of the Engineer. The required traffic control devices, warning devices and barriers shall be erected by the Contractor prior to creation of any hazardous condition and in conjunction with any necessary re-routing of traffic. The Contractor shall immediately remove, turn or cover any devices or barriers which do not apply to existing conditions. All traffic control devices shall conform to MUTCD standards and shall be clean and relatively undamaged. Damaged devices diminishing legibility and recognition, during either night or day conditions, are not acceptable for use.
- E. NO WAIVER OF LIABILITY: The Contractor shall conduct his operations in such a manner that no undue hazard will result due to the requirements of this article, and the procedures and policies described therein shall in no way act as a waiver of any of the terms of the liability of the Contractor or his surety.
- F. Contractor's Maintenance of Traffic Plan shall maintain continuous vehicular traffic at all times.
- G. The Changeable Variable Message Sign shall be used as necessary. The location, message, and duration shall be as directed by Engineer.
- H. In addition to above, the Contractor shall comply with INDIAN RIVER COUNTY TRAFFIC ENGINEERING DIVISION SPECIAL CONDITIONS FOR RIGHT-OF-WAY CONSTRUCTION in Appendix 6.

Item of Payment

Payment for the work specified in this item shall be made under:

Bid Item No. 102-1 – Maintenance of Traffic – Per Lump Sum

SECTION 104 - PREVENTION, CONTROL, AND ABATEMENT OF EROSION AND WATER POLLUTION

PART 1 – GENERAL

1.1 SCOPE

- A. This Section covers erosion control and the treatment of dewatering water and stormwater runoff from the construction site and work area. Pollution control measures shall prevent polluted or turbid waters from being discharged from the construction site or work area to

undeveloped portions of the site or offsite, including but not limited to Multiple Separate Storm Sewer Systems (MS4s) and Waters of the State.

- B. The OWNER considers pollution from dewatering water and stormwater runoff from a construction site or work area to be a very serious offense. The CONTRACTOR is solely responsible for preventing pollution caused by dewatering water and stormwater runoff from the construction site or work area. Note that state regulations do not allow mixing stormwater and dewatering groundwater in the same release – separate and independent discharges are required.
- C. Pollution control measures specified herein represent minimum standards to be adhered to by the CONTRACTOR throughout the Project’s construction. The OWNER reserves the right to require the CONTRACTOR to employ additional pollution control measures, when in the sole opinion of the OWNER, they are warranted. If site specific conditions require additional erosion and stormwater pollution control measures during any phase of construction or operation to prevent erosion or to control sediment or other pollution, beyond those specified in the Drawings, the Project’s approved Stormwater Pollution Prevention Plan (SWPPP), or herein, implement additional best management practices as necessary, in accordance with [Chapter 4, “Best Management Practices for Erosion and Sedimentation Control” of the Florida Erosion and Sediment Control Inspector’s Manual](#) and other references as may be applicable or required by regulatory permits.
- D. The OWNER may terminate this Contract if the CONTRACTOR fails to comply with this Section. Alternatively, the OWNER may halt the CONTRACTOR’s operations until the CONTRACTOR is in full compliance with this Section. If the OWNER halts the CONTRACTOR’s Work as a result of failure to comply with this Section, the Contract time clock will continue to run.
- E. In addition to these Specifications, comply with [Chapter 4 - “Best Management Practices for Erosion and Sedimentation Control”](#) and [Chapter 5 – “Best Management Practices for Dewatering” of the Florida Erosion and Sediment Control Inspector’s Manual](#). In the event of a conflict between the referenced chapters and these Specifications, the more stringent requirement shall prevail.
- F. Submit to SJRWMD a “Notice to District of Dewatering Activity” (SJRWMD Form No. 40C-2.900(12)) prior to commencement of dewatering in accordance with F.A.C. 40C-2.042(9). Provide a copy of the Notice to Indian River County.

1.2 PERMITS

- A. The OWNER has obtained certain permits for this project and they are listed in [paragraph 6.08.B of the EJCDC Standard General Conditions of the Construction Contract \(General Conditions\)](#). Per [paragraph 6.08.C of the General Conditions](#), apply for and obtain all other required federal, state, and local permits, licenses, sampling, and tests.

- B. Provide copies of all approved permits to the OWNER and ENGINEER and comply with all conditions contained in all permits at no extra cost to the OWNER. If there is a conflict between any permit requirement and these Specifications or requirements between permits, the more stringent specification or requirement shall govern.
- C. Pay for all required water quality sampling and laboratory tests.

1.3 GENERAL

- A. Do not begin any other construction work until the pollution control and treatment system has been constructed in accordance with approved plans, permits, and these Specifications; and the installed system has been examined by the OWNER for compliance.
- B. From time to time, the OWNER or ENGINEER will inspect the pollution control and treatment system and may take effluent samples for analysis by a testing laboratory selected and paid for by the OWNER. If at any time, the OWNER or ENGINEER determines that the pollution control and treatment system is not in compliance with the approved system, the OWNER or ENGINEER will shut the portion of the project down that is not in compliance, and it shall remain shut-down until the pollution control and treatment system is properly constructed or repaired, and complies with the approved pollution control and treatment system plans, specifications, contract documents, and permits.
- C. Schedule construction to minimize erosion and stormwater runoff from the construction site. Implement erosion control measures on disturbed areas as soon as practicable in portions of the site where construction activities have temporarily or permanently ceased, but in no case more than 7 days after the construction activity in that portion of the site has temporarily or permanently ceased. In addition to other temporary erosion control measures that may be implemented, application of polyacrylamide is required on all such disturbed areas within 7 days after the construction activity in that portion of the site has temporarily or permanently ceased, unless final landscaping has been installed. Polyacrylamide application shall be as specified herein. Include polyacrylamide application in the Project's SWPPP.
- D. Inspect each pollution control system at least once per day and after each rainfall event. Clean and maintain each pollution control system as required until the system is no longer needed. If a water quality violation occurs, immediately cease all work contributing to the water quality violation and correct the problem. Immediately report all water quality violations to the OWNER. Immediately report the discharge of any hazardous substance to the State Warning Point at 800-320-0519 or 850-413-9911.
- E. Discharge shall not violate State or local water quality standards in receiving waters, nor cause injury to the public health or to public or private property, nor to the Work completed or in progress. The receiving point for water from construction operations shall be approved by the applicable owner, regulatory agency, and the ENGINEER. The receiving point shall be shown on the Project SWPPP.

- F. Promptly repair all damage at no cost to the OWNER.

1.4 SUBMITTALS

- A. Shop Drawings: Submit shop drawings of the proposed pollution control and treatment systems in accordance with [Section 1340](#).
- B. Approved Stormwater Pollution Prevention Plan.
- C. “Contractor’s Affidavit Regarding Erosion Control and Treatment of Dewatering Water and Stormwater From Construction Activities”

1.5 STORMWATER TREATMENT AND EROSION CONTROL SYSTEM RESPONSIBILITY

- A. Prepare a site-specific design of the erosion and stormwater pollution control system. Install and maintain all erosion and stormwater pollution control devices under the supervision of a State Certified Stormwater, Erosion, and Sedimentation Control Inspector. Maintain the erosion and stormwater pollution control devices until in the ENGINEER’s sole opinion, the devices are no longer necessary (such time not to extend past the date the OWNER formally accepts the project as complete). Before beginning construction, submit to Indian River County, Florida Department of Environmental Protection (FDEP) and other applicable regulatory agencies for review and approval, a Stormwater Pollution Prevention Plan (SWPPP), prepared by the certified erosion control subcontractor. Construction shall not begin until the SWPPP has been approved by Indian River County, FDEP, and all applicable regulatory agencies. Submit the approved SWPPP to the ENGINEER before beginning construction. Include in the SWPPP, the “Contractor’s Affidavit Regarding Erosion Control and Treatment of Dewatering Water and Stormwater From Construction Activities” (located at the end of this Section).

1.6 “POLLUTION” AND CERTAIN UNCONTESTABLE POLLUTION EVENTS DEFINED

- A. With respect to this Section and as may be further defined in paragraphs [1.6.B](#), [1.6.C](#), and [1.6.D](#), “pollution” is the presence in off-site waters of any substances, contaminants, or manmade or human-induced impairment of off-site waters or alteration of the chemical, physical, biological, or radiological integrity of off-site water in quantities or at levels which are or may be potentially harmful or injurious to human health or welfare, animal or plant life, or property. Pollutants to be removed include but are not limited to, sediment and suspended solids, solid and sanitary wastes, phosphorus, nitrogen, pesticides, oil and grease, concrete truck washout, stucco mixer washout, curb machine washout, washout from other construction equipment, construction chemicals, and construction debris.
- B. When the Discharge is Directly Into an Existing Water Body An existing water body (including ditches and canals) is defined to be polluted by the CONTRACTOR’s operations when at any time, the turbidity of the water immediately downstream of the CONTRACTOR’s discharge point(s) is at least 29 nephelometric turbidity units (NTUs) higher than the turbidity of the background water upstream of the discharge point(s). [\[See Fla. Administrative Code 62-](#)

302.530] Exception: When the discharge is directly into or through an outfall discharging into “Outstanding Florida Waters,” designated by [Florida Statute 403.061\(27\)](#), the turbidity of the discharged water cannot exceed the turbidity of the immediate receiving water. The ENGINEER or OWNER shall determine the locations where the turbidity is measured.

- C. When the Discharge is not Directly Into an Existing Water Body In some instances, dewatering water or stormwater runoff from the construction site or work area may reach a water body indirectly, such as by overland flow. If the discharge water’s TSS and turbidity measurements exceed pre-construction background values by 20 percent for TSS and 29 NTUs for turbidity, then the discharge is defined to be polluted.
- D. When Pollution Always Occurs The discharge from a construction site or work area is defined to be polluted whenever the pH of the discharge is less than 6.5 or greater than 8.5, or whenever any of the following is present in the discharge water:
- (1) Hazardous waste or hazardous materials in any quantity,
 - (2) Any petroleum product or by-product in any quantity,
 - (3) Any chemical in any quantity, or
 - (4) Concentrated pollutants.
- E. Above paragraphs [1.6.B](#), [1.6.C](#), and [1.6.D](#) do not in any way, limit the types of conditions in which pollution may be determined to occur.

1.7 PENALTIES FOR NONCOMPLIANCE WITH THIS SECTION

- A. In addition to the OWNER’s specific remedies, if erosion or pollution is caused by dewatering water or stormwater runoff from the construction site, the OWNER may report the violations to Indian River County Stormwater Enforcement, SJRWMD, FDEP, Indian River Farms Water Control District (or other F. S. Chapter 298 Drainage District, as appropriate), and other pertinent regulatory or enforcement agencies.

PART 2 - MATERIALS AND INSTALLATION

2.1 GENERAL

- A. Polyacrylamide: As required in Paragraph 1.3.C, place polyacrylamide (PAM) on bare ground to reduce the potential for erosion and cover it with hay, jute, or mulch. PAM may also be used in water bodies to remove turbidity. In all cases, use the anionic form of polyacrylamide that does not stick to fish gills. For PAM information and its proper application, a contact is Applied Polymer Systems, Inc., (678) 494-5998, www.siltstop.com.
- B. Staked Silt Fences:
1. General: Use silt fences to control runoff from the construction site where the soil has been disturbed.
 2. Installation: Install per the manufacture’s recommendations and as specified herein. In general, install the silt fence in a manner that allows it to stop the water long enough for the sediment to settle while the water passes through the silt fence fabric.

All supporting posts shall be on the down-slope side of the fencing. Place the bottom of the fabric 6-inches minimum, under compacted soil to prevent the flow of sediment underneath the fence. Place silt fences away from the toe of slopes. Otherwise, work shall conform to Section 104 of the Florida Department of Transportation Standard Specifications for Road and Bridge Construction.

3. Product: All material shall be new and unused. Use FDOT Types III through IV silt fences where large sediment loads are anticipated, where slopes are 1:2 (vertical: horizontal) or steeper, or as directed by the ENGINEER; otherwise use FDOT Type II silt fence.

C. Turbidity Barriers:

1. General: Use turbidity barriers to control sediment contamination of rivers, lakes, ponds, canals, etc.
2. Installation: Install per the manufacturer's recommendations and per Section 104 of the Florida Department of Transportation Standard Specifications for Road and Bridge Construction unless directed otherwise by the ENGINEER.
3. Product: All material shall be new and unused. The turbidity barrier shall be a pervious barrier and the fabric color shall be yellow. Use staked turbidity barriers in water less than one-foot deep. Use floating turbidity barriers in water one-foot or deeper.

D. Sedimentation Control From Dewatering or Pumping Operations Using Filter Bags:

1. Filter bags shall be manufactured using a polypropylene non-woven geotextile and sewn by a double-needle machine, using a high strength nylon thread. The bag shall have a fill spout large enough to accommodate a 4-inch pump discharge hose. Straps shall be attached to the bag to secure the hose and prevent pumped water from escaping without being filtered.
2. Installation: Install in accordance with the manufacturer's specifications. Use as many filter bags as required, at no additional cost to the OWNER. Legally dispose of the bags offsite, at no cost to the OWNER. If the bags are placed on aggregate to facilitate filtration efficiency, do not use limerock aggregate – use non-calcareous rock.
3. Product: The filter bag shall be supplied with lifting straps.
 - a. "DIRTBAG 53 or 55 as applicable," supplied by ACF Environmental, Inc. (1-800-448-3636).
 - b. "DANDY DEWATERING BAG" supplied by Dandy Products, Inc. (1-800-591-2284).
 - c. Or equivalent.

E. Curb Inlet Protection:

1. Filter stormwater before it enters curb inlets.
2. Installation: Install in accordance with the manufacturer's specifications. Use as many of the specified filtration devices as required, at no additional cost to the OWNER.
3. Product: All materials shall be new and unused. The length of the curb inlet filtration device shall be at least 2-feet longer than the curb inlet opening.
 - a. "GUTTERBUDDY," supplied by ACF Environmental, Inc. (1-800-448-3636).

b. Or equivalent.

F. Catch Basin Protection:

1. Filter stormwater before it enters catch basins (drop inlets). The filter “sack” shall be manufactured from woven polypropylene geotextile and sewn by a double-needle machine, using a high strength nylon thread. The sack shall be manufactured to fit the opening of the catch basin or drop inlet and it shall have the following features: two dump straps attached at the bottom to facilitate emptying; lifting loops as an integral part of the system to be used to lift the sack from the basin; and a colored restraint chord approximately halfway up the sack to keep the sides away from the catch basin walls. The colored restraint chord shall also serve as a visual means of indicating when the sack should be emptied.
2. Installation: Install in each catch basin in accordance with the manufacturer’s specifications. Use as many of the specified filtration devices as required, at no additional cost to the OWNER.
3. Product: All materials shall be new and unused.
 - a. “SILTSACK” (regular flow), supplied by ACF Environmental, Inc. (1-800-448-3636).
 - b. “FloGuard+PLUS,” supplied by Kristar Enterprises, Inc. (1-800-579-8819).
 - c. Or equivalent.

G. Construction Site Egress Driveways: Minimize the transport of sediment and soil from the construction site or work area by vehicle wheels. Construct a crushed rock driving surface at the vehicle exit point(s). Locate the site egress driveways a minimum of 25 feet from all drainage inlets or pipes. Provide an area large enough to remove the sediment and soil from vehicle wheels before the vehicle leaves the construction site or work area. Provide wash-down stations as required to wash vehicle tires and retain all washwater on-site. Do not use limerock.

H. Rock and Stone for Erosion Control and Pollution Control and Treatment:

1. Crushed Limerock: Limerock shall not be used under any circumstance.
2. Acceptable Material: FDOT #4 non-calcareous aggregate, washed and meeting the requirements of FDOT Standard Specifications for Road and Bridge Construction, Section 901.

I. Hay Bales: Hay bales shall not be used.

PART 3 - EXECUTION

- A. Design, construct, and maintain the pollution control and treatment system to minimize erosion and capture and remove pollutants from the construction site and from all other areas disturbed by construction activities.
- B. Apply polyacrylamide in strict accordance with the polyacrylamide manufacturer/supplier’s recommendations and specifications.

- C. REPAIR ALL EROSION DAMAGE – At no additional cost to the OWNER and regardless of the state of completion of the Work, immediately clean all dirt and debris from all pipes and drainage structures; and repair all flooding, washouts, and all other erosion damage to the Work. This responsibility shall not end until Final Acceptance of the Work by the OWNER. Included is damage caused by erosion of any kind (e.g. wind, waves, stormwater runoff, hurricanes, etc.) including Acts of God. Restore all erosion damaged areas to design grades and elevations. Also, refer to [General Conditions 6.13.B](#).

Item of Payment

Payment for the work specified in this item shall be made under:

Bid Item No. 104-2 – Prevention, Control & Abatement of Erosion & Water Pollution - Per Lump Sum

PERMITTEE’S AFFIDAVIT REGARDING POLLUTION

This sworn statement is submitted to Indian River County for the following project:

Hallstrom Farmstead Pavilions

STATE OF _____

COUNTY OF _____

Personally, before me the undersigned authority, appeared

_____, who upon oath duly administered, stated as follows:

1. This sworn statement is submitted by the PERMITTEE,

_____ whose business address is

and (if applicable) its Federal Identification No.(FEIN) is _____

2. My name is _____ and my relationship to the

entity named above is _____

(if signing as Owner’s Agent, attach Letter of Authorization to Sign from Owner)

3. PERMITTEE understands and agrees that in addition to complying with the terms and conditions of the Stormwater Management System Permit issued by Indian River County, Permittee is responsible for complying with the terms and conditions of the following as applicable to the site:

- (a) State of Florida Generic Permit for Stormwater Discharge From Large and Small Construction Activities (for projects one acre or larger),
- (b) Stormwater Pollution Prevention Plan (regardless of project size),
- (c) St. Johns River Water Management District permit(s) (regardless of project size),
- (d) Florida Department of Environmental Protection permit(s) (regardless of project size),
- (e) All other permits required for this project not specifically listed herein, and
- (f) All Codes and Ordinances of Indian River County.

4. PERMITTEE understands and agrees that “pollution” as defined by Florida Statutes Chapter 403.031(7) includes: “. . . the presence in the outdoor atmosphere or waters of the state of any substances, contaminants, noise, or manmade or human-induced impairment of air or waters or alteration of the chemical, physical, biological, or radiological integrity of air or water in quantities or at levels which are or may be potentially harmful or injurious to human health or welfare, animal or plant life, or property or which unreasonably interfere with the enjoyment of life or property, including outdoor recreation unless authorized by applicable law.”

5. PERMITTEE understands and agrees that in addition to the definition set forth in Item 4 above, "pollution" is also defined by Florida Administrative Code 62-302.530 and as may be further defined in the Indian River County permit(s).
6. PERMITTEE understands that Indian River County requires the design, installation, and maintenance of proper erosion control measures at all times UNTIL Final Acceptance of the Project by the OWNER.
7. PERMITTEE understands that there are civil and criminal penalties for pollution listed in Florida Statutes Ch. 403.141 and Ch. 403.161 and that there are other penalties listed in Indian River County's permits, including but not limited to, Indian River County issuing a Cease and Desist Order for the project. CONTRACTOR understands that it may be liable for these and other penalties if offsite pollution occurs as a result of activities associated with the Project.
8. Transfer of Ownership or County Issued Permits:
 - (a) Transfer of Interest in Real Property: Within twenty-one (21) days of any transfer of ownership or control of the real property at which the permitted activity, facility, or system is located or authorized, the Permittee shall notify in writing, both the Indian River County Parks and Recreation Department and the Indian River County Stormwater Division of the transfer. Permittee shall provide the name, mailing address, and telephone number of the transferee and a copy of the instrument effectuating the transfer. Said notification is in addition to notifying the County Attorney's Office as required by County Code.
 - (b) Transfer of a County Permit. To transfer a County issued permit, Permittee must provide (1) the information required in Item 8(a); (2) a written statement from the proposed transferee that it will be bound by all terms and conditions of the permit; and (3) a new "Permittee's Affidavit" form properly executed by the transferee. Upon proper receipt of these items the County shall transfer the permit to the transferee.
 - (c) Permittee is encouraged to request a permit transfer prior to the sale or legal transfer of the real property at which a permitted facility, system, or activity is located or authorized. However, the transfer shall not be effective prior to the sale or legal transfer.
 - (d) An "Illicit Discharge Sign" must be present at the site at the time of transfer. Replacement or additional signs may be obtained from the Indian River County Public Works Department at a cost of \$30.00 per sign.

Under penalty of perjury, PERMITTEE declares that it has read the foregoing affidavit and the facts stated in it are true.

FURTHER AFFIANT SAYETH NAUGHT

CONTRACTOR: _____

Authorized Signature: _____

Printed Name: _____

Date: _____

Work Telephone: _____

Mobile Telephone: _____

STATE OF _____

COUNTY OF _____

Sworn to (or affirmed) and subscribed before me by means of physical presence or online notarization, this ____ day of _____ 20____, by _____ (name of person making statement).

(Signature of Notary Public - State of Florida)
(Print, Type, or Stamp Commissioned Name of Notary Public)

who is personally known to me or who has produced _____ as identification.

+ + END OF SECTION + +

SECTION 110 - CLEARING AND GRUBBING

The work specified in this item shall conform to Section 110 of the Florida Department of Transportation Standard Specifications for Road and Bridge Construction with the following modifications:

- A. Prior to any clearing and grubbing, the contractor will stake the right-of-way. Unimproved areas shall be cleared of trees, logs, stumps, brush, vegetation, rubbish and other perishable or objectionable matter within limits shown on the plans excepting for certain trees and shrubs shown on the plans or as directed by the Engineer which are to remain undisturbed and protected. Stumps and roots between slope stakes in cuts and in embankments 3 feet or less in depth shall be removed to a depth of 18 inches below subgrade. No stumps, roots, or perishable matter of any description shall remain under concrete slabs or footing, including pavement and sidewalks.
- B. No trees shall be removed or relocated until the Engineer or his representative has marked all trees to be saved, after a review of the project site with the Contractor's representative.
- C. Where the final pavement or structural work will be close to existing trees, the Contractor shall exercise care in the vicinity of the trees. Further, the Contractor shall saw cut along the edge of the outside limits of the stabilization, structure subgrade or sidewalk to a minimum depth of 4 feet below the finish grade and paint with a commercial grade pruning paint the ends of all sawn roots. If directed by the Engineer or where shown on the drawings, work shall be done by hand in order to protect the trees.
- D. The Contractor shall exercise care when working in the vicinity of all trees to remain so as to not damage or remove major root structures. The Contractor shall not pull hair or major root structures. All severed roots shall be sawn clean and paint with pruning paint. Stumps, roots, etc., shall be completely removed and disposed of by the Contractor. Undesirable, dead, and/or damaged trees (as so designated by the Engineer) shall be removed.
- E. All trees to be removed shall be disposed off site; burning will be strictly prohibited.
- F. All trees or shrubs which are to remain shall be preserved and protected by the Contractor. Where the removal of valuable trees or shrubs specifically for transplanting is required, this work shall be done in cooperation with the Owner and at no additional expense to the Owner.
- G. No additional payment will be made, nor will additional work, or change orders be authorized for work needed to remove, relocate, protect, or otherwise account for in the construction of the work depicted in the plans, for any feature, or item that would be apparent from a careful inspection of the site and review of the plans, even though such feature or item is not specifically called out in the plans. It is therefore essential the contractor make such inspection and review.
- H. The unit price bid for this item shall include the cost of all labor, tools, and equipment

necessary to excavate, remove, and dispose of those items as directed by the Engineer and where designated on the Drawings. The cost of restoration and backfill and compaction for the specific area of removal shall also be included under this item.

Item of Payment

Payment for the work specified in this item shall be made under:

Bid Item No. 110-1-1 – Clearing and Grubbing – Per Lump Sum

SECTION 570 - PERFORMANCE TURF

The work specified in this item shall conform to Section 570 of the Florida Department of Transportation Standard Specifications for Road and Bridge Construction.

- A. Description: Sod for the project shall be of the variety that is common to the area and of a variety approved by the Engineer. This work shall also include mowing, to be mowed at maximum 6" height with a mulching mower.
- B. Work Included: Scope of Work: The work specified in this section consists of the establishing of a stand of grass, within the project, right-of-way, easements, and other areas indicated on the Drawings, by furnishing and placing grass sod. Also included are fertilizing, watering and maintenance as required to assure a healthy stand of grass. Two applications of fertilizer will be required with the initial application being fertilizer and the second application being "weed and feed".
- C. Guarantee: All sodded areas shall be guaranteed for one year after date of final acceptance.

Replacement of Defective Sod: Any dead sod or sod showing (less than 95% of a square) indication of probable non-survival or lack of health and vigor, or which do not exhibit the characteristics to meet specifications, shall be replaced within two weeks of notice from Owner or Engineer. All replacement sod shall be furnished/installed at no additional cost to the Owner and shall be guaranteed for three months. All replacement shall meet original specifications.

The Contractor shall notify the Owner and Engineer ten days prior to the end of the guarantee period and such guarantee shall be extended until notification is received.

At the end of the guarantee period, all sod that is dead or in unsatisfactory growth shall be replaced within two weeks.

- D. Fertilizer: Commercial fertilizers shall comply with the Indian River County Fertilizer Ordinance 2013-012 and Supplement Ordinance 2013-014 (see Appendix 7).
- E. Water for Grassing: Contractor shall provide the water used in the sodding operations as necessary to meet the requirements of Article 570-3.6.

F. Preparation of Ground: The area over which the sod is to be placed shall be scarified or loosened to a depth and then raked smooth and free from debris. Where the soil is sufficiently loose and clean, the Owner, at his discretion, may authorize the elimination of ground preparation.

G. Application of Fertilizer: Before applying fertilizer, the soil pH shall be brought to a range of 6.0 - 7.0.

Contractor shall apply two (2) applications. The initial shall be fertilizer and the second application shall be "weed and feed".

The fertilizer shall be spread uniformly over the sodded area at the rate of 436 pounds per acre, or 10 pounds per 1,000 square feet, by a spreading device capable of uniformly distributing the material at the specified rate.

Contractor shall apply applications as per manufacturer's specification. All tickets from bags shall be handed over to the County Inspector.

On steep slopes, where the use of a machine for spreading or mixing is not practicable, the fertilizer shall be spread by hand and raked in and thoroughly mixed with the soil to a depth of approximately 2 inches.

H. Placing Sod: The sod shall be placed on the prepared surface, with edges in close contact and shall be firmly and smoothly embedded by light tamping with appropriate tools.

Where sodding is used in drainage ditches, the setting of the pieces shall be staggered so as to avoid a continuous seam along the line of flow. Along the edges of such staggered areas, the offsets of individual strips shall not exceed 6 inches. In order to prevent erosion caused by vertical edges at the outer limits, the outer pieces of sod shall be tamped so as to produce a featheredge effect.

Where sodding is placed abutting paved shoulder, the contractor is to ensure that the finished sod elevation is 1½" below paved shoulder.

On slopes greater than 3:1, the Contractor shall prevent the sod from sliding by means of wooden pegs driven through the sod blocks into firm earth, at suitable intervals.

Sodding shall not be performed when weather and soil conditions are, in the Engineer's opinion, unsuitable for proper results.

Sod shall be placed around all structures, equipment pads, etc.

I. Watering: The areas on which the sod is to be placed shall contain sufficient moisture, as determined by the Engineer, for optimum results. After being placed, the sod shall be kept in a moist condition to the full depth of the rooting zone for at least 2 weeks. Thereafter, the Contractor shall apply water as needed until the sod roots and starts to grow for a minimum of 60 days (or until final acceptance, whichever is latest).

J. Maintenance: The Contractor shall, at his expense, maintain the sodded areas in a satisfactory condition until final acceptance of the project. Such maintenance shall include

repairing of any damaged areas and replacing areas in which the establishment of the grass stand does not appear to be developing satisfactorily.

Replanting or repair necessary due to the Contractor's negligence, carelessness or failure to provide routine maintenance shall be at the Contractor's expense.

The Contractor shall maintain the sodded area up to the final acceptance date as directed by the Engineer. Grass height shall not exceed 6" without mowing. Clippings shall be removed from sidewalk.

- K. Article 570-9. The first two paragraphs under this Article are deleted and the following is added:

The contract unit price for performance turf shall include the costs of sod, fertilizer (2 applications), sidewalk sweeping after mowing, mowing, pegging disposal of clippings, water, tools, equipment, labor and all other incidentals necessary.

Item of Payment

Payment for the work specified in this item shall be made under:

Bid Item No. 570-1-2 – Performance Turf (Sod) (Bahia) - Per Square Yard

SECTION 999 - RECORDS/AS-BUILTS

GENERAL

Maintain, prepare and provide the ENGINEER with record documents as specified below, except where otherwise specified or modified within the scope of work provided in the specific project contract documents. The Contractor and/or Developer shall be responsible for, and required to provide, Record Drawings as outlined in this section.

MAINTENANCE OF RECORD DOCUMENTS:

1. Maintain in CONTRACTOR's field office in clean, dry, legible condition complete sets of the following project documents: Drawings, Specifications, Addenda, approved Shop Drawings, samples, photographs, Change Orders, other modifications of Contract Documents, test records, survey data, Field Orders, and all other documents pertinent to CONTRACTOR'S Work.
2. Provide files and racks for proper storage and easy access.
3. Make documents available at all times for inspection by ENGINEER and OWNER.
4. Do not use record documents for any other purpose and do not remove them from the field office.
5. Label each document "RECORD DRAWING" in 2-inch high printed letters.
6. Keep record documents current at all times.
7. No work shall be permanently concealed until the required record data has been obtained.

RECORD / AS-BUILT DRAWINGS

- A. During the construction operation, the CONTRACTOR shall maintain records of all deviations from the approved Project Plans and Specifications and shall prepare therefrom "RECORD" drawings showing correctly and accurately all changes and deviations from the work made during construction to reflect the work as it was actually constructed.
- B. The Record/As-Built survey shall be performed and subsequent plans prepared by a Professional Surveyor and Mapper, registered in the state of Florida and certified to the standards set forth in Chapter 472, Florida Statutes and Chapter 5J-17.050 Florida Administrative Code (Florida Minimum Technical Standards).
- C. Field measurements of vertical or horizontal dimensions of constructed improvements shall be obtained so that the constructed facility can be delineated in such a way that the location of the construction may be compared with the construction plans. Clearly shown by symbols, notations, or delineations, those constructed improvements located by the survey.
- D. All vertical information (elevations) provided on the Record Drawings shall be referenced to the North American Vertical Datum of 1988 (NAVD 88) unless otherwise specified by the Project Engineer.
- E. The horizontal information provided on the Record Drawings shall be referenced to the State of Florida, State Plane Coordinate System, Florida East Zone as established by Global Positioning System (GPS) which meets or exceeds Third Order Class I Accuracy Standards according to current publication of the Federal Geodetic Control Committee (FGCC) procedures.
- F. All Record/As-Built drawings shall be prepared in digital format (ACAD Civil 3D 2013) and shall utilize the digital design drawings as prepared by the Project Engineer as a base for the Record/As-Built drawings. It is the responsibility of the Surveyor to request these files from the Contractor or Project Owner in order to produce the Record/As-Built drawing set.
- G. ALL improvements proposed to be constructed as shown on the approved construction plans shall be field measured upon completion and shown on the Record/As-Built survey. Any improvements that appear in both plan and profile views shall show the Record/As-Built information in both views.
- H. The following items are required to be shown on all Indian River County project Record/As-Built drawings submitted to the County:

DRAINAGE:

- 1. Right-of-way Swale/Drainage – All culvert inverts, elevations and station offsets; inlet grate and bottom elevations; swale beginning and end bottom elevations; and highs and lows along top of bank. Size of swale.

2. Pipe Culvert/PVC Sleeves – All inverts, pipe size, stations and offsets.
3. Outfalls – All pipe inverts, pipe size, elevations and station offsets, weir box elevations, weir elevation, bleeder elevation and sizes.
4. Roadway/Off Site Drainage – All inverts, elevations and station offsets; manhole top elevation; grate top elevations.
5. Retention Ponds – Provide perimeter elevations, grade breaks, depths and calculated pond areas at control elevation and grade breaks above and below water surface. Show as-built of typical cross section as shown on design plan.

SURVEY CONTROL

1. Install/re-establish: It shall be the contractor's responsibility to hire a Professional Surveyor and Mapper as defined per Chapter 472, Florida Statutes, to replace any horizontal and vertical control shown on the engineering plans that was destroyed during construction.
2. New roadway alignment control points (survey baseline or controlling line and all points as indicated on the plans or control sheet) upon final roadway completion. Include all intersections and side streets. State plane coordinates and elevations for all control points.
3. If shown on plans or not: Any Public Land Corner or Governmental Survey Control point(s), vertical control (bench marks), property corners destroyed and/or disturbed during the scope of the project shall be properly re-established as per standards as set forth within Florida Statutes, Administrative code and Minimum Technical Standards for that type of survey. All said surveying mentioned above shall be performed under the direct supervision of a registered Professional Surveyor and Mapper in the state of Florida and certified accordingly. Said Governmental agency(s) shall be notified in writing of disturbance and re-establishments.

RECORD/AS-BUILTS DRAWINGS FORMAT - SUBMITTAL

- A. ENGINEER will supply the CONTRACTOR with the electronic file of the approved construction plans for the input of the As-Built (record) information.
- B. CONTRACTOR shall deliver seven (7) certified sets of Record/As-Builts with Electronic Drawing files prepared in AutoCAD Civil 3D 2013 AND PDF format or in current version as agreed by the ENGINEER.
- C. CONTRACTOR's surveyor shall review, sign and seal As-Builts or Record drawing(s). Said drawing(s) shall clearly state type of survey, positional tolerances, adhere and be certified to by a registered Professional Surveyor and Mapper in the state of Florida, any standards set forth by Florida Statutes, Administrative code and Minimum Technical Standards for As-Built/Record surveys.
- D. All Record/As-Built drawings are subject to review and approval by County Surveyor.

ACCURACY

The CONTRACTOR will be held responsible for the accuracy and completeness of Record Drawings and Electronic As-Builts and shall bear any costs incurred in finding utilities as a result of incorrect data furnished by the CONTRACTOR.

COMPLETION OF WORK

Upon Substantial Completion of the Work, deliver Record Drawings/As-Built Drawings to ENGINEER. Final payment will not be made until satisfactory record documents are received and approved by ENGINEER.

Item of Payment

Payment for the work specified in this item shall be made under:

Bid Item No. 999-1 – Construction Layout/Record Drawings – Per Lump Sum

[The remainder of this page left blank intentionally]

Board of Professional Surveyors and Mappers
Record As-Built Survey Checklist

Lic. Name _____ Date: _____

Project Name: Hallstrom Farmstead Pavilions

Project No.: IRC-xxxx

Chapter 61G17-6 Minimum Technical Standards F.A.C.

61G17-6.003 General Survey, Map, and Report Content Requirements

☐ **(1) REGULATORY OBJECTIVE: The public must be able to rely on the accuracy of measurements and maps produced by a surveyor and mapper. In meeting this objective, surveyors and mappers must achieve the following minimum standards of accuracy, completeness, and quality:**

☐ **(a) Accuracy of survey measurements based on the type of survey and expected use.**

☐ **(b) Measurements made in accordance with the United States standard, feet or meters.**

☐ **(c) Records of measurements maintained for each survey (check field notes.)**

☐ **(d) Measurement and computation records dated.**

☐ **(e) Measurement and computation records substantiate the survey map.**

☐ **(f) Measurement and computation records support accuracy statement (closure calculations or redundant measurements, if applicable.)**

(2) Other More Stringent Requirements:

☐ **(a) Met more stringent requirements set by federal, state, or local governmental agencies.**

(3) Other Standards and/or Requirements that Apply to All Surveys, Maps, and/or Survey Products:

☐ **(a) REGULATORY OBJECTIVE: In order to avoid misuse of a survey and map, the surveyor and mapper must adequately communicate the survey results to the public through a map, report, or report with an attached map.**

(b) Survey map or report identified the responsible surveyor and mapper and contain standard content. In meeting this objective, surveyors and mappers must meet the following minimum standards of accuracy, completeness, and quality:

☒ (c) Type survey stated on map and report:

- | | |
|------------------------------------|---|
| As-Built Survey | Construction Layout Survey |
| Boundary Survey | Control Survey |
| Condominium Survey | Hydrographic Survey |
| Mean High Water Line Survey | Specific or Special Purpose Survey |
| Quantity Survey | Topographic Survey |
| Record Survey | |

- ☒ (d) Name, certificate of authorization number, and street and mailing address of the business entity on the map and report.**
- ☒ (e) Name and license number of the surveyor and mapper in responsible charge.**
- ☒ (f) Name, license number, and street and mailing address of a surveyor and mapper practicing independent of any business entity on the map and report.**
- ☒ (g) Survey date (date of data acquisition.)**
- ☒ (h) Revision date for any graphic revisions (when survey date does not change.)**
- ☒ (i) Map and report statement “Survey map and report or the copies thereof are not valid without the signature and the original raised seal of a Florida licensed surveyor and mapper.”**
- ☒ (j) Insurance statement in ¼” high letters “The survey depicted here is not covered by professional liability insurance” if there is no professional liability insurance.**
- ☒ (k) Additions or deletions to survey maps or reports by other than the signing party or parties is prohibited without written consent of the signing party or parties.**
- ☒ (l) All computed data or plotted features shown on survey maps supported by accurate survey measurements unless clearly stated otherwise.**
- ☒ (m) Bearings, distances, coordinates, and elevations shown on a survey map shall be substantiated by survey measurements unless clearly stated otherwise.**
- ☒ (n) Bearing reference (well established and monumented line)**
- ☒ (o) A designated “north arrow”**
- ☒ (p) Stated scale or graphic scale**
- ☒ (q) Abbreviations in legend or notes.**
- ☒ (r) Special conditions and any necessary deviation from the standards noted upon the map or report.**
- ☒ (s) Responsibility for all mapped features stated on the map or report**
- ☒ (t) Map or report clearly states the individual primarily responsible for the map or report when mapped features have been integrated with others.**

(u) Map Accuracy.

(1) Vertical Feature Accuracy:

- ☐ **(a) Vertical Control:** Field-measured control for elevation information shown upon survey maps or reports shall be based on a level loop or closure to a second benchmark.
- ☐ **(b) Closure in feet must be accurate to a standard of plus or minus .05 ft. times the square root of the distance in miles.**
- ☐ **(c) All surveys and maps or reports with elevation data shall indicate the datum and a description of the benchmark(s) upon which the survey is based.**
- ☐ **(d) Minor elevation data may be obtained on an assumed datum provided the base elevation of the datum is obviously different than the established datum.**

(2) Horizontal Feature Accuracy:

- ☐ **(a) Horizontal Control:** All surveys and maps or reports expressing or displaying features in a publicly published coordinate system shall indicate the coordinate datum and a description of the control points upon which the survey is based.
- ☐ **(b) Minor coordinate data may be obtained and used on an assumed datum provided the numerical basis of the datum is obviously different than a publicly published datum.**
- ☐ **(c) The accuracy of control survey data shall be verified by redundant measurements or traverse closures. All control measurements shall achieve the following closures:**

Commercial/High Risk Linear: 1 foot in 10,000 feet;
Suburban: Linear: 1 foot in 7,500 feet;
Rural: Linear: 1 foot in 5,000 feet;
- ☐ **(d) When statistical procedures are used to calculate survey accuracies, the maximum acceptable positional tolerance, based on the 95% confidence level, should meet the same equivalent relative distance standards as set forth in 61G17- 6.003(3)(p)(2.)(c) F.A.C.**
- ☐ **(e) Intended Display Scale:** All maps or reports of surveys produced and delivered with digital coordinate files must contain a statement to the effect of: "This map is intended to be displayed at a scale of 1/___ or smaller".

61G17-6.004 Specific Survey, Map, and Report Requirements

(1) As-Built/Record Survey:

- ☐ (a) Obtained field measurements of vertical or horizontal dimensions of constructed improvements so that the constructed facility can be delineated in such a way that the location of the construction may be compared with the construction plans.**
- ☐ (b) Clearly shows by symbols, notations, or delineations, those constructed improvements located by the survey.**
- ☐ (c) All maps prepared shall meet applicable minimum technical standards.**
- ☐ (d) Vertical and horizontal accuracy of the measurements made shall be such that it may be determined whether the improvements were constructed consistent with planned locations.**

(END OF SECTION)

APPENDIX 1

SITE MAPS & PROJECT PLANS

Hallstrom Farmstead Conceptual Site Plan

Indian River County, Florida

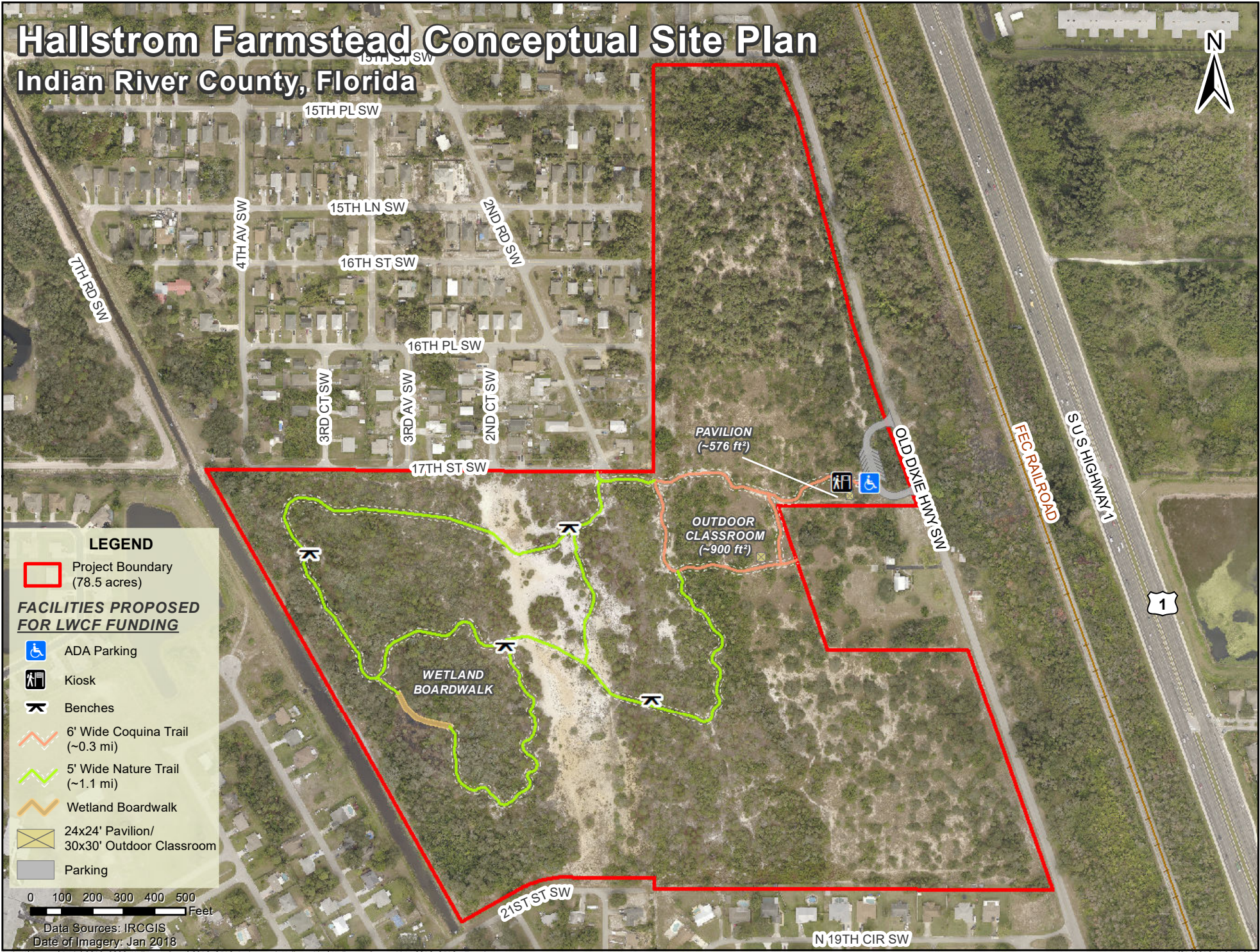

LEGEND

- Project Boundary (78.5 acres)

FACILITIES PROPOSED FOR LWCF FUNDING

- ADA Parking
- Kiosk
- Benches
- 6' Wide Coquina Trail (~0.3 mi)
- 5' Wide Nature Trail (~1.1 mi)
- Wetland Boardwalk
- 24x24' Pavilion/
30x30' Outdoor Classroom
- Parking

0 100 200 300 400 500
Feet

Data Sources: IRCGIS
Date of Imagery: Jan 2018

Hallstrom Farmstead Location Map

Indian River County, Florida

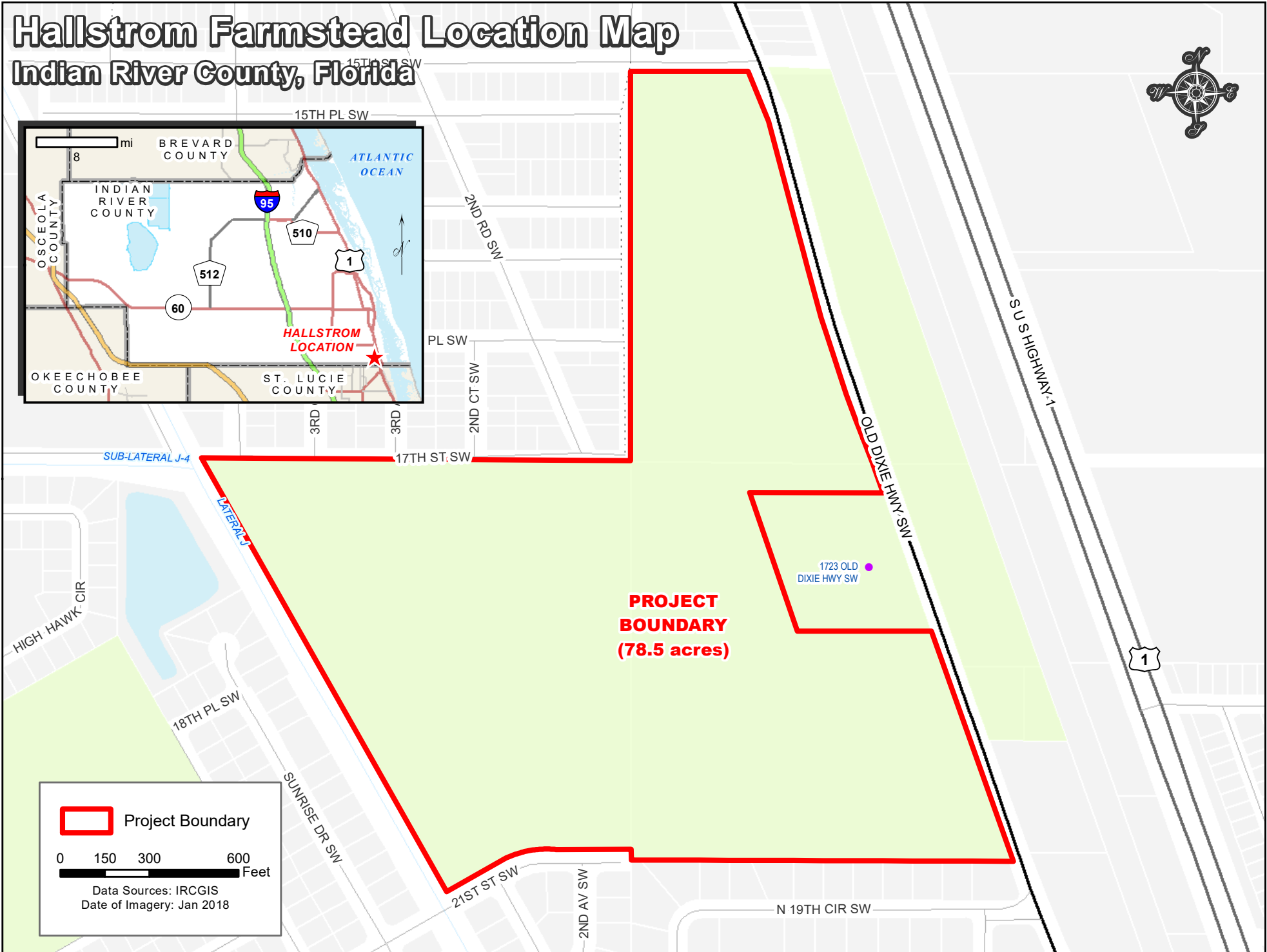

 Project Boundary

0 150 300 600 Feet

Data Sources: IRCGIS
Date of Imagery: Jan 2018

APPENDIX 2

RCP PAVILION SPECIFICATIONS

SECTION 10 73 46 PRE-FABRICATED SITE SHELTERS

PART 1 GENERAL

1.1 SUMMARY

- A. Design, fabrication, finishing, and delivery of pre-engineered, glue laminated wood, factory-fabricated site shelter.
- B. Site work related to installation, by Contractor or Owner, including:
 - 1. Unloading and temporary storage, if any.
 - 2. Soil testing, if necessary.
 - 3. Site preparation.
 - 4. Column foundations, rebar, anchor bolts, and anchor embedment.
 - 5. Concrete slab and embedment.
 - 6. Erection.
 - 7. Field touch up painting of factory finishes, if necessary.
- C. Site access for delivery vehicles shall be provided by Owner.

1.2 SYSTEM DESCRIPTION

- A. Design shall meet or exceed applicable building code.
- B. Pre-Engineered, pre-fabricated packages shall include laminated wood beams, laminated wood columns, T&G wood roof deck, wood fascia, and column to beam connection fasteners.
- C. Pre-engineered, pre-fabricated package shall be designed as a fixed base, heavy timber construction structure. Superstructure components (columns, beams, & connection) shall be factory pre-cut and pre-drilled. Roof deck shall be delivered in specified lengths such that joints occur over beams for minimal cutting, Fascia and nailer shall be delivered in industry standard lengths and field cut by installer.
- D. Field labor required to install the pre-fabricated parts. Structure is shipped knocked down. Onsite welding shall not be required or permitted.

1.3 REFERENCES

- A. American National Standard for Wood Products – Structural Glued Laminated Timber (ANSI A-190.1)
- B. American Institute of Timber Construction (AITC)
- C. American Plywood Association (APA)
- D. Engineered Wood Association (EWA)

- E. American Society of Testing Material (ASTM)
 - 1. ASTM A307 - Standard Specification for Carbon Steel Bolts and Studs
 - 2. ASTM A500 - Standard Specification for Cold-Formed Welded and Seamless Carbon Steel Structural Tubing in Rounds and Shapes
 - 3. ASTM A572 - Standard Specification for High-Strength Low-Alloy Columbium-Vanadium Structural Steel
- F. American Institute of Steel Construction (AISC)
- G. American Welding Society (AWS)
- H. Steel Structures Painting Council (SSPC); SSPC-SP10 - Near-White Blast Cleaning
- I. Leadership in Energy and Environmental Design (LEED)

1.4 QUALITY ASSURANCE

- A. Designer Qualifications: Design under direct supervision of a Professional Engineer experienced in design of this type of work and licensed in the State where the Project is located.
- B. Manufacturer Qualifications: Company experienced in design and manufacture of shelters of the type specified, and having the following:
 - 1. Minimum five years of experience in design and fabrication of pre-fabricated glued laminated wood shelters.
 - 2. Three references of similar shelters completed within the past two years within a 100-mile radius of project.
 - 3. Fabricator membership in American Institute of Steel Construction (AISC), requiring quality control documentation and procedures. Provide current AISC shop certification upon request.
 - 4. All welding shall be performed to AWS standards by AWS certified welders. Provide welding certification upon request.
 - 5. Fabricator membership in AITC and APA/EWS. Members shall be marked (in an unseen finish product location) with an AITC or APA/EWS Quality Mark. Additionally, a Certificate of Conformance shall be provided, indicating conformance with ANSI/AITC A190.1-2002.
- C. Perform the work in accordance with applicable federal, State, and local building and safety codes and regulations.

1.5 SUBMITTALS

- A. Minimum 5 sets of shop drawings, showing all details of construction, including foundation sizes, reinforcement, and locations. Drawings shall be furnished on minimum 22" x 34" paper. Prints on ledger, legal or letter size paper are unacceptable.
 - 1. Provide the licensed professional engineer's state stamp or seal on the shop drawings.
 - 2. Provide the licensed professional engineer's state stamp or seal on the structural calculations.

- B. Selection Samples: For each finish product specified, color charts representing manufacturer's full range of available colors.
- C. Warranty
 - 1. Provide minimum five-year warranty against manufacturer defects.
 - 2. Provide roofing manufacturer's limited warranty.

1.6 DELIVERY, STORAGE, AND PROTECTION

- A. Individually wrap factory-finished structural components in fiber reinforced paper to protect the finish during transit.
- B. Wood roof deck shall be load wrapped and banded together in bundles that do not exceed 2,000 lbs.
- C. Shipped knocked down for minimal shipping charges.
- D. Deliver products to project site in manufacturer's protective packaging.
- E. Follow shelter manufacturer's recommendations and instructions, including those printed on the shop drawings. To minimize damage during unloading, use only padded forks or non-marring slings.
- F. Prefinished materials not being immediately installed must be protected from sunlight.
- G. Store products in manufacturer's unopened packaging well off the ground and covered out of weather until ready for installation.

PART 2 PRODUCTS

2.1 GENERAL

- A. Model: LW-G3030-03 as manufactured by RCP Shelters, Inc.
- B. Size and dimensions
 - 1. Shape: square
 - 2. Dimensions: 30' x 30' (reference preliminary drawings)
 - 3. Roof Style: gable
 - 4. Roof Pitch: 3:12
 - 5. Eave Height: minimum clearance at eave or beneath ornamentation shall be 7'-6"
 - 6. Quantity: 1
- C. Approved Manufacturer: RCP Shelters, Inc.
 - 1. 2100 SE Rays Way, Stuart, FL 34994.
 - 2. Toll Free: 800-525-0207
 - 3. Direct Line: (772) 288-3600
 - 4. Fax: 772-288-0207
 - 5. Website: www.rcpshelters.com

6. Email: info@rcpshelters.com

D. Substitutions: Products other than specified must request in writing to Architect and receive approval, in writing, by addendum at least ten (10) days prior to the bid date. Unapproved alternates will not be allowed. See Instructions to Bidders for further instructions.

2.2 STRUCTURAL COMPONENTS

A. Steel

1. Plates: ASTM A572 Grade 50
2. Finish: Powder Coat
 - a. Pre-blast inspection to catch and remove oil, grease, and other coatings impeding contaminants
 - b. Steel grit blasted to near white condition in accordance with SSPC-SP10, removing all oil residue, mil scale, weld spatter, and slag
 - c. Five stage phosphate wash (includes detergent, phosphate, rust protectant sealant)
 - d. Epoxy powder coat primer
 - e. Double topcoat TGIC polyester powder coat; color to be selected from manufacturer's standard color chart by Owner.
 - f. Primer plus finish coats shall be 7-12 mils thick
 - g. All materials inspected to meet 100% coating, proper cure, film thickness, and impact resistance
 - h. Wet-coat alternatives shall not be acceptable.
3. Fasteners: 4 gauge hot-dipped galvanized annular ring nails

B. Glued Laminated Wood

1. Species: Southern Yellow Pine
2. Appearance Grade: Architectural
3. Lamination Thickness: 2" Nominal
4. Adhesive: Resorcinol
5. Stress Combination: 24F-V3
6. Preservation Treatment: CCA 0.4 pcf prior to gluing (columns only)
7. Size: Per engineered drawings

C. Structural Wood Roof Deck

1. Species: #1 grade Southern Yellow Pine, kiln dried
2. Treatment: none
3. Size: nominal 2" x 8"
4. Pattern: center matched, tongue and groove, with veed edges 1 side (EV1S)

D. Fascia

1. Species: C or Better Clear Alaskan Yellow Cedar
2. Size: nominal 2" x 6"

E. Factory Stained Wood

1. Beams, deck, and fascia shall receive factory applied semi-transparent wood stain, recommended to preserve the beauty of the wood. The color shall be chosen from manufacturer's standard color chart.

- F. Metal Roof System: Galvalume® metal roof panels with exposed fasteners.
 - 1. Profile: 5V Crimp
 - 2. Panel Gauge: minimum 26-gauge
 - 3. Panel Width: 2'-0"
 - 4. Panel Length: Precut to the length from the eave to the ridge
 - 5. Panel Orientation: Ribs shall run with the pitch of the roof for proper drainage
 - 6. Trim: Matching roof trim and fasteners
 - 7. Finish: Factory pre-finished with Kynar 500® paint system; color to be selected by Owner from standard color chart
 - 8. Underlayment: [HydraShell MAX](#)

PART 3 EXECUTION

3.1 EXAMINATION

- A. Verify that site earthwork has been performed as required for satisfactory installation.

3.2 PREPARATION

- A. Install footings and columns as specified by shelter manufacturer on approved shop drawings.

3.3 INSTALLATION

- A. Perform installation in accordance with applicable federal, State, and local building and safety codes.
- B. Structural special inspections, if required, are shall be arranged and paid for by the Contractor or Owner.
- C. Install shelter in accordance with manufacturer's approved shop drawing and good construction practices.
- D. Install slab in accordance with shelter manufacturer's shop drawings. Slab perimeter dimensions determined by Owner.

3.4 CLEANING AND PROTECTION

- A. Clean installed work to like-new condition.
- B. Protect installed products until completion of project.
- C. Touch-up, repair, or replace damaged finishes before Substantial Completion. Touch up paint provided by manufacturer.

END OF SECTION

PRELIMINARY DRAWING – NOT FOR CONSTRUCTION

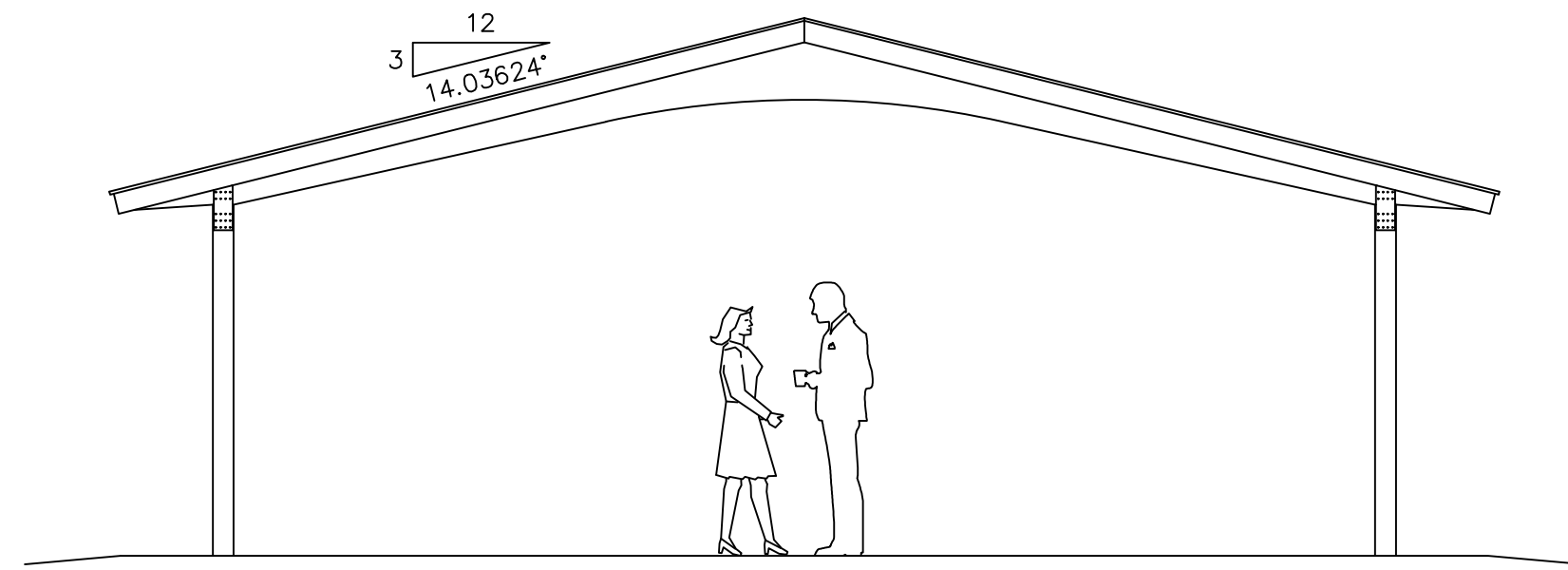

END ELEVATION

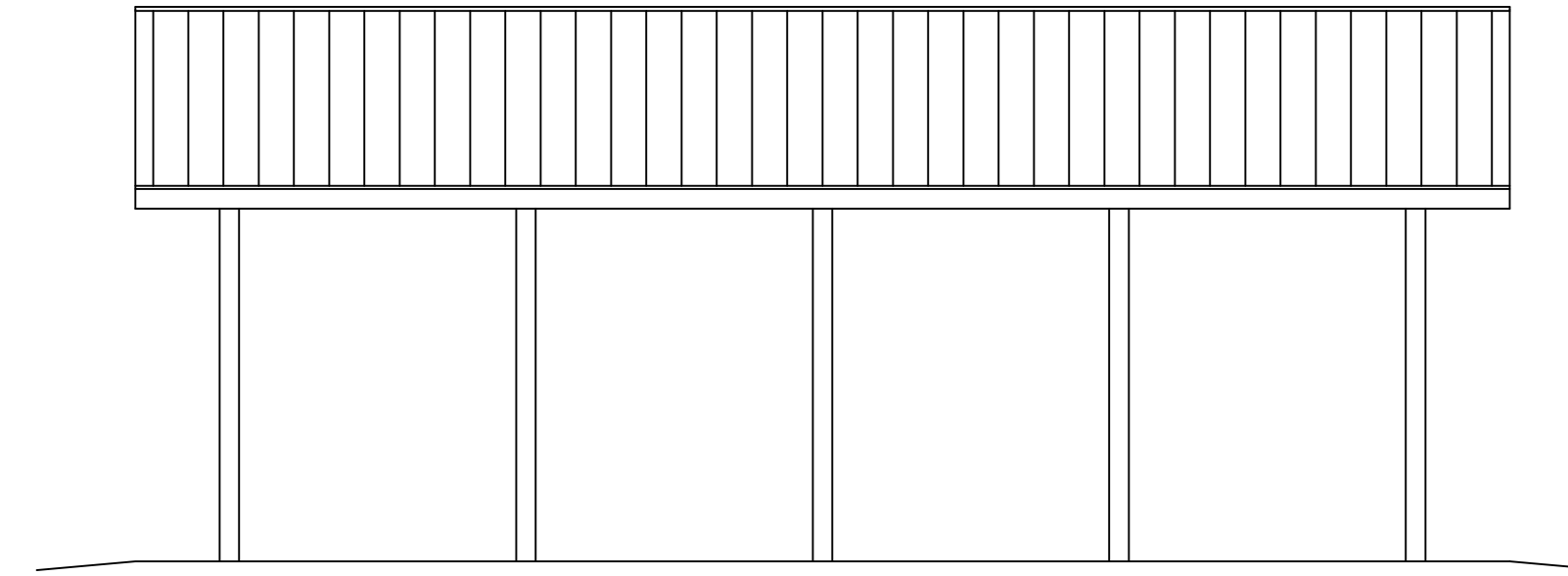

SIDE ELEVATION

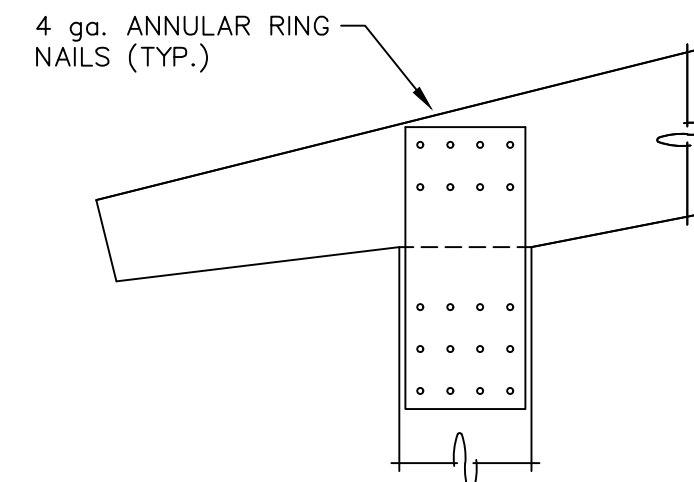

COLUMN TO BEAM CONNECTION

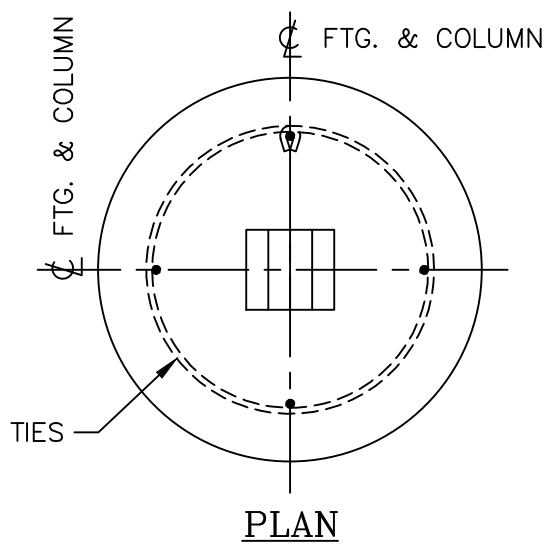

PLAN

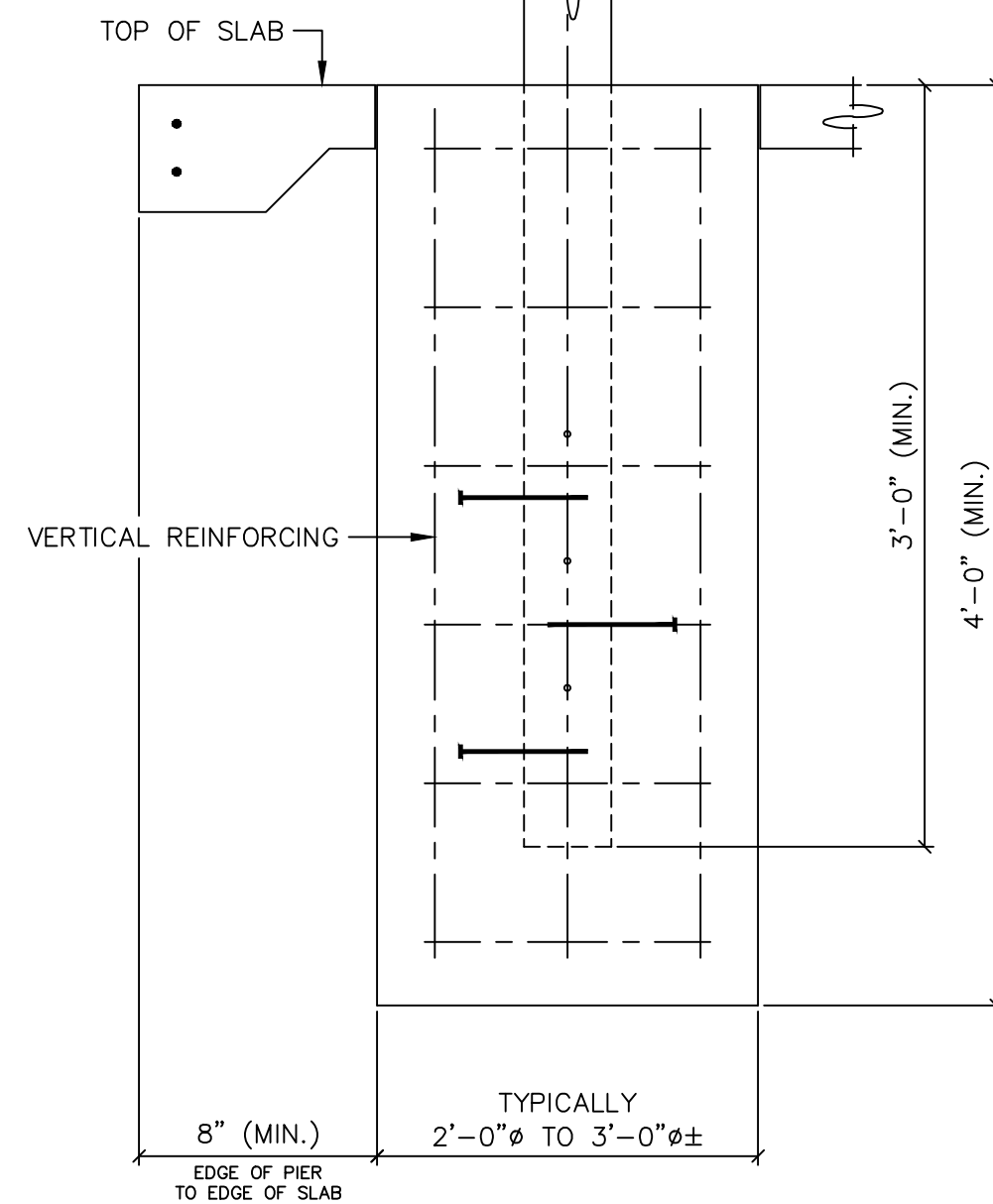

COLUMN PIER DETAIL

ACTUAL DESIGN WILL VARY DUE TO BUILDING CODE REQUIREMENTS AND MAY BE SUBSTANTIALLY LARGER

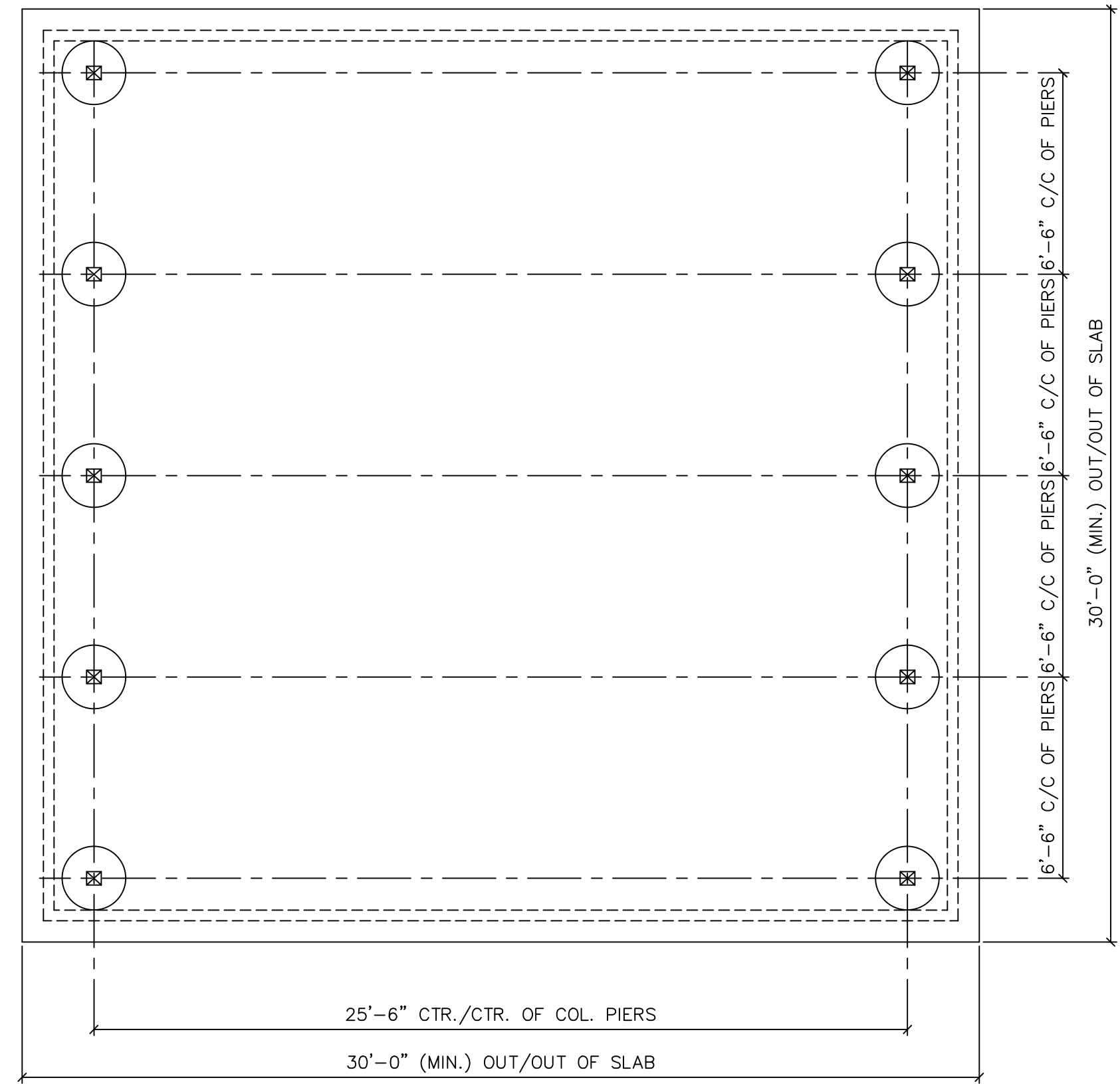

FOUNDATION PLAN



ROOF FRAMING PLAN

THIS PRINT IS THE PROPERTY OF RCP SHELTERS AND IS NOT TO BE USED, COPIED, OR REPRODUCED WITHOUT THEIR EXPRESSED WRITTEN PERMISSION.

LW-G3030-03

NUMBER OF PURLINS MAY VARY DEPENDING UPON DESIGN LOADS. SIZES AND SPACING OF PURLINS TO BE DETERMINED DURING FINAL DESIGN.

RCP SHELTERS, INC.

2100 SE RAYS WAY STUART, FL 34994 PO BOX 25 STUART, FL 34995-0025
 ■ SHELTERS ■ PAVILIONS ■ CONCESSIONS ■ KIOSKS ■ FABRIC SHADE
 ■ RESTROOMS ■ BANDSHELLS ■ MINI-SHELTERS ■ DUGOUTS ■ FABRIC SAIL
 Phone 800-525-0207 Fax 772-288-0207
 www.rcpselters.com Email info@rcpselters.com

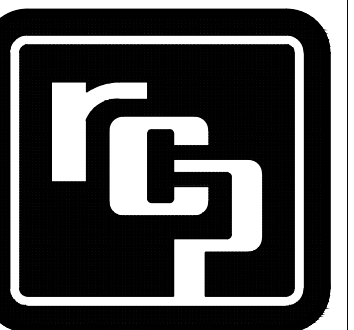

PROJ. NO.:

DRAWN: AJR 10-16-15

CHK'D:

REV 1:

REV 2:

REV 3:

REV 4:

REV 5:

CAD NO.: LW-G3030-03

EEC JOB NO.:

SHEET NO.:

1X OF 1X

“LW-G” MODEL RECTANGULAR PAVILION W/ WOOD COLUMNS

SUGGESTED INSTALLATION INSTRUCTIONS



- Read installation instructions thoroughly prior to assembly.
- Bracing material may be required during assembly.
- Installation should be done as soon as possible to reduce the effects of weathering. All wood parts received for this unit should be placed in a dry place, if field erection is not immediately performed.
- Loctite should be used on all threaded hardware.
- Do not over tighten bolts (if applicable).
- Do not tighten any nuts, bolts, rods, etc. until the unit is completely assembled.

INSTALLATION INSTRUCTIONS

- STEP 1: Lay out center lines on selected site as shown on Floor Plan. Dig (augur) holes for concrete piers according to RCP shop drawings and area code requirements for this type of structure.
- STEP 2: To place columns, set 2" x 6" securely nailed to stakes driven in the ground. The inside face of the boards should be the back edge of the columns. The bottoms should be at the desired finish floor elevation. Measuring from the top of the columns, place marks on the column for top of floor elevation.
- STEP 3: Special hardened, annularly grooved spikes are now pounded into the columns (6 per column) as shown on drawings.
- NOTE: Columns may be required to be field drilled for rebar (supplied by GC) in place of spikes.
- STEP 4: Place columns into the augured holes. The marks on the columns should align with the bottom edge of the 2" x 6". Spike through the 2" x 6" into the column. Securely brace the tops of the columns back into the ground. Call RCP prior to setting columns if not 100% clear on their location.
- STEP 5: Pour approximately ½ yard of concrete into each of the holes. Check location, plumbness, & elevation of the columns. Make necessary adjustments. If adjustments were necessary, puddle concrete to eliminate any voids. Allow concrete to cure for 48 hours before proceeding with installation.
- STEP 6: A lift truck or small crane should be used to hoist pitched & tapered beams in place, atop columns. Use nylon, well padded, web slings (do NOT use chains or cables). Starting at one end, position the beams so the seat cut (flat) aligns with the column. Remove protective paper from beams. Connect the beam to column as shown for CONN S-1. Set all beams in same manner. Brace each beam as it is erected (min. 2x4 "X" brace each side to adjoining beam).
- STEP 7: Reference drawings for instructions for unloading, handling, and cutting of 2" x 8" decking. Deck is supplied in specific lengths to minimize cutting. Install deck layout in accordance with the instructions on the drawings. Deck should be laid so the "v" joint is visible from under shelter. Drive courses tight with blocking. Longer pieces may require come-along straps to pull tight. Attach each piece of deck to each support with nails per drawings. The decking should be covered with roofing felt as soon as bays are completed. If the installation cannot be completed in one day, the decking that has been installed should be covered before leaving the site.
- STEP 8: Snap line and cut deck up the rake. Install fascia to the eaves and decking with 12d nails (see nailing schedule). The fascia is not pre-cut; cutting and fitting shall be performed by installer on site. Fascia joints to occur over beam ends and should be mitered. Corners should be mitered. Install 2x4 nailer at rake.

“LW-G” MODEL RECTANGULAR PAVILION W/ WOOD COLUMNS SUGGESTED INSTALLATION INSTRUCTIONS



- STEP 9: Check to be sure all nuts, bolts, etc. are “snug tight,” and no nails protrude through wooden decking or fascia boards.
- STEP 10: Apply waterproofing package (may not be supplied by RCP) per manufacturer’s specs and/or RCP drawings.
- STEP 11: Form and pour the concrete pad per owner’s specifications. Allow 48 hours for concrete to set. This step may be done at same time as foundations are poured.
- RCP recognizes that there are optional installation methods that may prove expedient for large projects, or experienced, well-equipped erectors.
 - Please call (772) 288-3600 for any questions or concerns. Please have plans available, and reference the five digit project number.

APPENDIX 3

FDEP LAND & WATER CONSERVATION FUND GRANT AGREEMENT



FLORIDA DEPARTMENT OF Environmental Protection

Marjory Stoneman Douglas Building
3900 Commonwealth Boulevard
Tallahassee, Florida 32399-3000

Rick Scott
Governor
Carlos Lopez-Canera
Lt. Governor
Noah Valenstein
Secretary

February 26, 2019

Ms. Beth Powell
Conservation Lands Manager
Indian River County
5500 77th Street
Vero Beach, FL 32960-5523

Re: Hallstrom Farmstead Conservation Area Improvements
LWCF Project No. 12-00695

Dear Ms. Powell:

The attached contains the fully executed grant agreement for the above referenced project. Moreover, please visit our website at: <https://floridadep.gov/ooo/land-and-recreation-grants>, to read and familiarize yourself with the LWCF Manual, the LWCF Florida Administrative Rule, the required Commencement Documentation Checklist, as well as the Project Status Report Form.

In addition, the Reimbursement Schedules and the Project Completion Documentation Checklist can be found on our website when that time approaches.

This information has been provided for your review, as it will be extremely helpful and ensure compliance with the administrative requirements of this grant.

Reminders:

1. Construction or acquisition cannot begin until all project commencement documentation has been submitted and approved by this office. This process should be completed by **August 21, 2019**; again the **commencement checklist** and other forms may be found at <https://floridadep.gov/ooo/land-and-recreation-grants> under **LWCF Administrative Forms**.
1. Quarterly status reports are required - **January 5, May 5, and September 5**. Please be sure to summarize work accomplished, problems encountered (if any), and provided color photographs of development progression and the final as-built product.
2. The Department will not process your reimbursements request until the Grantee completes the project and staff reviews and approves all Completion Documentation.

Ms. Beth Powell
Page Two
February 26, 2019

3. The project should be completed before the completion date set forth in the grant agreement **May 31, 2022** and all reimbursement requests and closeout documents submitted within thirty days after completion.

5. If the project cannot be completed on time, a written request for an extension should be submitted at least sixty (60) days prior to the completion date. Please state the reason for the extension and the additional time needed to complete the project.

If you have any questions, please contact our office at (850) 245-2501. We look forward to working with you on this project.

Sincerely,

A handwritten signature in black ink that reads "Tamika Bass". The signature is written in a cursive, flowing style.

Tamika Bass
Community Assistant Consultant
Land and Recreation Grants Section
Office of Operations
Mail Station #585

**STATE OF FLORIDA
DEPARTMENT OF ENVIRONMENTAL PROTECTION
Standard Grant Agreement**

This Agreement is entered into between the Parties named below, pursuant to Section 215.971, Florida Statutes:

1. Project Title (Project): Hallstrom Farmstead Conservation Area Improvements Agreement Number: LW695

2. Parties State of Florida Department of Environmental Protection,
3900 Commonwealth Boulevard
Tallahassee, Florida 32399-3000 (Department)

Grantee Name: Indian River County Entity Type: A Local Government
Grantee Address: 5500 77th Street, Vero Beach, FL 32960-5523 FEID: 59-6000674 (Grantee)

3. Agreement Begin Date: September 24, 2018 Date of Expiration: September 30, 2022

4. Project Number: LW695 Project Location(s): 1601 Old Dixie Highway SW, Vero Beach, FL 32962
(If different from Agreement Number)

Project Description: Install a 30' x 30' pavilion with concrete floor (includes survey, earthwork and construction),
a 24' x 24' pavilion/outdoor classroom with stabilized pervious base floor (includes survey, earthwork and construction); Survey and construct a boardwalk; Create a .3 mile
ADA accessible loop trail and a 1.1 mile nature trail; Construct a parking area.

5. Total Amount of Funding:	Funding Source?	Award #s or Line Item Appropriations:	Amount per Source(s):
<u>\$148,500.00</u>	<input type="checkbox"/> State <input checked="" type="checkbox"/> Federal	<u>Line Item No. 1686, GAA, FY 2018-2019</u>	<u>\$148,500.00</u>
	<input type="checkbox"/> State <input type="checkbox"/> Federal		
	<input checked="" type="checkbox"/> Grantee Match		<u>\$148,500.00</u>
Total Amount of Funding + Grantee Match, if any:			<u>\$297,000.00</u>

6. Department's Grant Manager Name: Tarnika Bass or successor
Address: 3900 Commonwealth Boulevard
MS# 585
Tallahassee, FL 32399
Phone: 850-245-2501
Email: tarnika.bass@floridadep.gov

Grantee's Grant Manager Name: Ms. Beth Powell or successor
Address: 5500 77th Street
Vero Beach, FL 32960-5523
Phone: 772-226-1873
Email: bpowell@ircgov.com

7. The Parties agree to comply with the terms and conditions of the following attachments and exhibits which are hereby incorporated by reference:

<input checked="" type="checkbox"/> Attachment 1: Standard Terms and Conditions Applicable to All Grants Agreements
<input checked="" type="checkbox"/> Attachment 2: Special Terms and Conditions
<input checked="" type="checkbox"/> Attachment 3: Grant Work Plan
<input checked="" type="checkbox"/> Attachment 4: Public Records Requirements
<input checked="" type="checkbox"/> Attachment 5: Special Audit Requirements
<input checked="" type="checkbox"/> Attachment 6: Program-Specific Requirements
<input checked="" type="checkbox"/> Attachment 7: LW695 Grant Award Terms (Federal) *Copy available at https://facts.fldfs.com , in accordance with §215.985, F.S.
<input checked="" type="checkbox"/> Attachment 8: Federal Regulations and Terms (Federal)
<input type="checkbox"/> Additional Attachments (if necessary):
<input checked="" type="checkbox"/> Exhibit A: Progress Report Form
<input type="checkbox"/> Exhibit B: Property Reporting Form
<input checked="" type="checkbox"/> Exhibit C: Payment Request Summary Form
<input type="checkbox"/> Exhibit D: Quality Assurance Requirements for Grants
<input type="checkbox"/> Exhibit E: Advance Payment Terms and Interest Earned Memo
<input type="checkbox"/> Additional Exhibits (if necessary):

8. The following information applies to Federal Grants only and is identified in accordance with 2 CFR 200.331(a)(1):

Federal Award Identification Number(s) (FAIN):	P18AP00600
Federal Award Date to Department:	9/24/18
Total Federal Funds Obligated by this Agreement:	\$148,500.00
Federal Awarding Agency:	National Park Service
Award R&D?	<input type="checkbox"/> Yes <input checked="" type="checkbox"/> N/A

IN WITNESS WHEREOF, this Agreement shall be effective on the date indicated by the Agreement Begin Date above or the last date signed below, whichever is later.

Indian River County

Grantee Name

By

Bob Solari
(Authorized Signature)

Bob Solari, Chairman

Print Name and Title of Person Signing

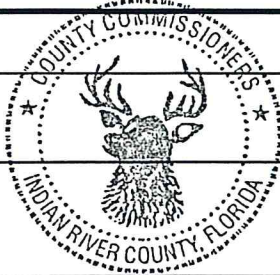

GRANTEE

February 5, 2019

Date Signed

State of Florida Department of Environmental Protection

By

Cathy DeHaven
Secretary or Designee

Cathy DeHaven Director Division of State Lands - DEP

Print Name and Title of Person Signing

DEPARTMENT

2-21-2019
Date Signed

ATTEST: Jeffrey R. Smith, Clerk
of Court and Comptroller

BY:

Randi Wauerton
Deputy Clerk

APPROVED AS TO FORM
AND LEGAL SUFFICIENCY

BY

[Signature]
DYLAN REINGOLD
COUNTY ATTORNEY

STATE OF FLORIDA
DEPARTMENT OF ENVIRONMENTAL PROTECTION
STANDARD TERMS AND CONDITIONS
APPLICABLE TO GRANT AGREEMENTS

ATTACHMENT 1

1. Entire Agreement.

This Grant Agreement, including any Attachments and Exhibits referred to herein and/or attached hereto (Agreement), constitutes the entire agreement between the parties with respect to the subject matter hereof and supersedes all prior agreements, whether written or oral, with respect to such subject matter. Any terms and conditions included on Grantee's forms or invoices shall be null and void.

2. Grant Administration.

- a. Order of Precedence. If there are conflicting provisions among the documents that make up the Agreement, the order of precedence for interpretation the Agreement is as follows:
- i. Standard Grant Agreement
 - ii. Attachments other than Attachment 1, in numerical order as designated in the Standard Grant Agreement
 - iii. Attachment 1, Standard Terms and Conditions
 - iv. The Exhibits in the order designated in the Standard Grant Agreement
- b. All approvals, written or verbal, and other written communication among the parties, including all notices, shall be obtained by or sent to the parties' Grant Managers. All written communication shall be by electronic mail, U.S. Mail, a courier delivery service, or delivered in person. Notices shall be considered delivered when reflected by an electronic mail read receipt, a courier service delivery receipt, other mail service delivery receipt, or when receipt is acknowledged by recipient. If the notice is delivered in multiple ways, the notice will be considered delivered at the earliest delivery time.
- c. If a different Grant Manager is designated by either party after execution of this Agreement, notice of the name and contact information of the new Grant Manager will be submitted in writing to the other party and maintained in the respective parties' records. A change of Grant Manager does not require a formal amendment or change order to the Agreement.
- d. This Agreement may be amended, through a formal amendment or a change order, only by a written agreement between both parties. A formal amendment to this Agreement is required for changes which cause any of the following: (1) an increase or decrease in the Agreement funding amount; (2) a change in Grantee's match requirements; (3) a change in the expiration date of the Agreement; and/or (4) changes to the cumulative amount of funding transfers between approved budget categories, as defined in Attachment 3, Grant Work Plan, that exceeds or is expected to exceed twenty percent (20%) of the total budget as last approved by Department. A change order to this Agreement may be used when: (1) task timelines within the current authorized Agreement period change; (2) the cumulative transfer of funds between approved budget categories, as defined in Attachment 3, Grant Work Plan, are less than twenty percent (20%) of the total budget as last approved by Department; and/or (3) fund transfers between budget categories for the purposes of meeting match requirements. This Agreement may be amended to provide for additional services if additional funding is made available by the Legislature.
- e. All days in this Agreement are calendar days unless otherwise specified.

3. Agreement Duration.

The term of the Agreement shall begin and end on the dates indicated in the Standard Grant Agreement, unless extended or terminated earlier in accordance with the applicable terms and conditions. The Grantee shall be eligible for reimbursement for work performed on or after the date of execution through the expiration date of this Agreement, unless otherwise specified in Attachment 2, Special Terms and Conditions. However, work performed prior to the execution of this Agreement may be reimbursable or used for match purposes if permitted by the Special Terms and Conditions.

4. Deliverables.

The Grantee agrees to render the services or other units of deliverables as set forth in Attachment 3, Grant Work Plan. The services or other units of deliverables shall be delivered in accordance with the schedule and at the pricing outlined in the Grant Work Plan. Deliverables may be comprised of activities that must be completed prior to Department making payment on that deliverable. The Grantee agrees to perform in accordance with the terms and conditions set forth in this Agreement and all attachments and exhibits incorporated by the Standard Grant Agreement.

5. Performance Measures.

The Grantee warrants that: (1) the services will be performed by qualified personnel; (2) the services will be of the kind and quality described in the Grant Work Plan; (3) the services will be performed in a professional and workmanlike manner in accordance with industry standards and practices; (4) the services shall not and do not infringe upon the intellectual property rights, or any other proprietary rights, of any third party; and (5) its employees, subcontractors, and/or subgrantees shall comply with any security and safety requirements and processes, if provided by Department, for work done at the Project Location(s). The Department reserves the right to investigate or inspect at any time to determine whether the services or qualifications offered by Grantee meet the Agreement requirements. Notwithstanding any provisions herein to the contrary, written acceptance of a particular deliverable does not foreclose Department's remedies in the event deficiencies in the deliverable cannot be readily measured at the time of delivery.

6. Acceptance of Deliverables.

- a. Acceptance Process. All deliverables must be received and accepted in writing by Department's Grant Manager before payment. The Grantee shall work diligently to correct all deficiencies in the deliverable that remain outstanding, within a reasonable time at Grantee's expense. If Department's Grant Manager does not accept the deliverables within 30 days of receipt, they will be deemed rejected.
- b. Rejection of Deliverables. The Department reserves the right to reject deliverables, as outlined in the Grant Work Plan, as incomplete, inadequate, or unacceptable due, in whole or in part, to Grantee's lack of satisfactory performance under the terms of this Agreement. The Grantee's efforts to correct the rejected deliverables will be at Grantee's sole expense. Failure to fulfill the applicable technical requirements or complete all tasks or activities in accordance with the Grant Work Plan will result in rejection of the deliverable and the associated invoice. Payment for the rejected deliverable will not be issued unless the rejected deliverable is made acceptable to Department in accordance with the Agreement requirements. The Department, at its option, may allow additional time within which Grantee may remedy the objections noted by Department. The Grantee's failure to make adequate or acceptable deliverables after a reasonable opportunity to do so shall constitute an event of default.

7. Financial Consequences for Nonperformance.

- a. Withholding Payment. In addition to the specific consequences explained in the Grant Work Plan and/or Special Terms and Conditions, the State of Florida (State) reserves the right to withhold payment when the Grantee has failed to perform/comply with provisions of this Agreement. None of the financial consequences for nonperformance in this Agreement as more fully described in the Grant Work Plan shall be considered penalties.
- b. Corrective Action Plan. If Grantee fails to correct all the deficiencies in a rejected deliverable within the specified timeframe, Department may, in its sole discretion, request that a proposed Corrective Action Plan (CAP) be submitted by Grantee to Department. The Department request that Grantee specify the outstanding deficiencies in the CAP. All CAPs must be able to be implemented and performed in no more than sixty (60) calendar days.
 - i. The Grantee shall submit a CAP within ten (10) days of the date of the written request from Department. The CAP shall be sent to Grant Manager for review and approval. Within ten (10) days of receipt of a CAP, Department shall notify Grantee in writing whether the CAP proposed has been accepted. If the CAP is not accepted, Grantee shall have ten (10) days from receipt of Department letter rejecting the proposal to submit a revised proposed CAP. Failure to obtain Department approval of a CAP as specified above may result in Department's termination of this Agreement for cause as authorized in this Agreement.
 - ii. Upon Department's notice of acceptance of a proposed CAP, Grantee shall have ten (10) days to commence implementation of the accepted plan. Acceptance of the proposed CAP by Department does not relieve Grantee of any of its obligations under the Agreement. In the event the CAP fails to correct or eliminate performance deficiencies by Grantee, Department shall retain the right to require additional or further remedial steps, or to terminate this Agreement for failure to perform. No actions approved by Department or steps taken by Grantee shall preclude Department from subsequently asserting any deficiencies in performance. The Grantee shall continue to implement the CAP until all deficiencies are corrected. Reports on the progress of the CAP will be made to Department as requested by Department's Grant Manager.
 - iii. Failure to respond to a Department request for a CAP or failure to correct a deficiency in the performance of the Agreement as specified by Department may result in termination of the Agreement.

8. Payment.

- a. **Payment Process.** Subject to the terms and conditions established by the Agreement, the pricing per deliverable established by the Grant Work Plan, and the billing procedures established by Department, Department agrees to pay Grantee for services rendered in accordance with Section 215.422, Florida Statutes (F.S.).
- b. **Taxes.** The Department is exempted from payment of State sales, use taxes and Federal excise taxes. The Grantee, however, shall not be exempted from paying any taxes that it is subject to, including State sales and use taxes, or for payment by Grantee to suppliers for taxes on materials used to fulfill its contractual obligations with Department. The Grantee shall not use Department's exemption number in securing such materials. The Grantee shall be responsible and liable for the payment of all its FICA/Social Security and other taxes resulting from this Agreement.
- c. **Maximum Amount of Agreement.** The maximum amount of compensation under this Agreement, without an amendment, is described in the Standard Grant Agreement. Any additional funds necessary for the completion of this Project are the responsibility of Grantee.
- d. **Reimbursement for Costs.** The Grantee shall be paid on a cost reimbursement basis for all eligible Project costs upon the completion, submittal, and approval of each deliverable identified in the Grant Work Plan. Reimbursement shall be requested on Exhibit C, Payment Request Summary Form. To be eligible for reimbursement, costs must be in compliance with laws, rules, and regulations applicable to expenditures of State funds, including, but not limited to, the Reference Guide for State Expenditures, which can be accessed at the following web address: www.myfloridacfo.com/aadir/reference_guide/.
- e. **Invoice Detail.** All charges for services rendered or for reimbursement of expenses authorized by Department pursuant to the Grant Work Plan shall be submitted to Department in sufficient detail for a proper pre-audit and post-audit to be performed. The Grantee shall only invoice Department for deliverables that are completed in accordance with the Grant Work Plan.
- f. **Interim Payments.** Interim payments may be made by Department, at its discretion, if the completion of deliverables to date have first been accepted in writing by Department's Grant Manager.
- g. **Final Payment Request.** A final payment request should be submitted to Department no later than sixty (60) days following the expiration date of the Agreement to ensure the availability of funds for payment. However, all work performed pursuant to the Grant Work Plan must be performed on or before the expiration date of the Agreement.
- h. **Annual Appropriation Contingency.** The State's performance and obligation to pay under this Agreement is contingent upon an annual appropriation by the Legislature. This Agreement is not a commitment of future appropriations. Authorization for continuation and completion of work and any associated payments may be rescinded, with proper notice, at the discretion of Department if the Legislature reduces or eliminates appropriations.
- i. **Interest Rates.** All interest rates charged under the Agreement shall be calculated on the prevailing rate used by the State Board of Administration. To obtain the applicable interest rate, please refer to: www.myfloridacfo.com/Division/AA/Vendors/default.htm.
- j. **Refund of Payments to the Department.** Any balance of unobligated funds that have been advanced or paid must be refunded to Department. Any funds paid in excess of the amount to which Grantee or subgrantee is entitled under the terms of the Agreement must be refunded to Department.

9. Documentation Required for Cost Reimbursement Grant Agreements and Match.

If Cost Reimbursement or Match is authorized in Attachment 2, Special Terms and Conditions, the following conditions apply. Supporting documentation must be provided to substantiate cost reimbursement or match requirements for the following budget categories:

- a. **Salary/Wages.** Grantee shall list personnel involved, position classification, direct salary rates, and hours spent on the Project in accordance with Attachment 3, Grant Work Plan in their documentation for reimbursement or match requirements.
- b. **Overhead/Indirect/General and Administrative Costs.** If Grantee is being reimbursed for or claiming match for multipliers, all multipliers used (i.e., fringe benefits, overhead, indirect, and/or general and administrative rates) shall be supported by audit. If Department determines that multipliers charged by Grantee exceeded the rates supported by audit, Grantee shall be required to reimburse such funds to Department within thirty (30) days of written notification. Interest shall be charged on the excessive rate.
- c. **Contractual Costs (Subcontractors).** Match or reimbursement requests for payments to subcontractors must be substantiated by copies of invoices with backup documentation identical to that required from Grantee. Subcontracts which involve payments for direct salaries shall clearly identify the personnel involved, salary rate per hour, and hours spent on the Project. All eligible multipliers used (i.e., fringe benefits, overhead, indirect,

and/or general and administrative rates) shall be supported by audit. If Department determines that multipliers charged by any subcontractor exceeded the rates supported by audit, Grantee shall be required to reimburse such funds to Department within thirty (30) days of written notification. Interest shall be charged on the excessive rate. Nonconsumable and/or nonexpendable personal property or equipment costing \$1,000 or more purchased for the Project under a subcontract is subject to the requirements set forth in Chapters 273 and/or 274, F.S., and Chapter 69I-72, Florida Administrative Code (F.A.C.) and/or Chapter 69I-73, F.A.C., as applicable. The Grantee shall be responsible for maintaining appropriate property records for any subcontracts that include the purchase of equipment as part of the delivery of services. The Grantee shall comply with this requirement and ensure its subcontracts issued under this Agreement, if any, impose this requirement, in writing, on its subcontractors.

- i. For fixed-price (vendor) subcontracts, the following provisions shall apply: The Grantee may award, on a competitive basis, fixed-price subcontracts to consultants/contractors in performing the work described in Attachment 3, Grant Work Plan. Invoices submitted to Department for fixed-price subcontracted activities shall be supported with a copy of the subcontractor's invoice and a copy of the tabulation form for the competitive procurement process (e.g., Invitation to Bid, Request for Proposals, or other similar competitive procurement document) resulting in the fixed-price subcontract. The Grantee may request approval from Department to award a fixed-price subcontract resulting from procurement methods other than those identified above. In this instance, Grantee shall request the advance written approval from Department's Grant Manager of the fixed price negotiated by Grantee. The letter of request shall be supported by a detailed budget and Scope of Services to be performed by the subcontractor. Upon receipt of Department Grant Manager's approval of the fixed-price amount, Grantee may proceed in finalizing the fixed-price subcontract.
 - ii. If the procurement is subject to the Consultant's Competitive Negotiation Act under section 287.055, F.S. or the Brooks Act, Grantee must provide documentation clearly evidencing it has complied with the statutory or federal requirements.
- d. Travel. All requests for match or reimbursement of travel expenses shall be in accordance with Section 112.061, F.S.
- e. Direct Purchase Equipment. For the purposes of this Agreement, Equipment is defined as capital outlay costing \$1,000 or more. Match or reimbursement for Grantee's direct purchase of equipment is subject to specific approval of Department, and does not include any equipment purchased under the delivery of services to be completed by a subcontractor. Include copies of invoices or receipts to document purchases, and a properly completed Exhibit B, Property Reporting Form.
- f. Rental/Lease of Equipment. Match or reimbursement requests for rental/lease of equipment must include copies of invoices or receipts to document charges.
- g. Miscellaneous/Other Expenses. If miscellaneous or other expenses, such as materials, supplies, non-excluded phone expenses, reproduction, or mailing, are reimbursable or available for match or reimbursement under the terms of this Agreement, the documentation supporting these expenses must be itemized and include copies of receipts or invoices. Additionally, independent of Grantee's contract obligations to its subcontractor, Department shall not reimburse any of the following types of charges: cell phone usage; attorney's fees or court costs; civil or administrative penalties; or handling fees, such as set percent overages associated with purchasing supplies or equipment.
- h. Land Acquisition. Reimbursement for the costs associated with acquiring interest and/or rights to real property (including access rights through ingress/egress easements, leases, license agreements, or other site access agreements; and/or obtaining record title ownership of real property through purchase) must be supported by the following, as applicable: Copies of Property Appraisals, Environmental Site Assessments, Surveys and Legal Descriptions, Boundary Maps, Acreage Certification, Title Search Reports, Title Insurance, Closing Statements/Documents, Deeds, Leases, Easements, License Agreements, or other legal instrument documenting acquired property interest and/or rights. If land acquisition costs are used to meet match requirements, Grantee agrees that those funds shall not be used as match for any other Agreement supported by State or Federal funds.
10. **Status Reports.**

The Grantee shall submit status reports quarterly, unless otherwise specified in the Attachments, on Exhibit A, Progress Report Form, to Department's Grant Manager describing the work performed during the reporting period, problems encountered, problem resolutions, scheduled updates, and proposed work for the next reporting period. Quarterly status reports are due no later than twenty (20) days following the completion of the quarterly reporting period. For the purposes of this reporting requirement, the quarterly reporting periods end on March 31, June 30, September 30 and December 31. The Department will review the required reports submitted by Grantee within thirty (30) days.

11. Retainage.

The following provisions apply if Department withholds retainage under this Agreement:

- a. The Department reserves the right to establish the amount and application of retainage on the work performed under this Agreement up to the maximum percentage described in Attachment 2, Special Terms and Conditions. Retainage may be withheld from each payment to Grantee pending satisfactory completion of work and approval of all deliverables.
- b. If Grantee fails to perform the requested work, or fails to perform the work in a satisfactory manner, Grantee shall forfeit its right to payment of the retainage associated with the work. Failure to perform includes, but is not limited to, failure to submit the required deliverables or failure to provide adequate documentation that the work was actually performed. The Department shall provide written notification to Grantee of the failure to perform that shall result in retainage forfeiture. If the Grantee does not to correct the failure to perform within the timeframe stated in Department's notice, the retainage will be forfeited to Department.
- c. No retainage shall be released or paid for incomplete work while this Agreement is suspended.
- d. Except as otherwise provided above, Grantee shall be paid the retainage associated with the work, provided Grantee has completed the work and submits an invoice for retainage held in accordance with the invoicing procedures under this Agreement.

12. Insurance.

- a. Insurance Requirements for Sub-Grantees and/or Subcontractors. The Grantee shall require its sub-grantees and/or subcontractors, if any, to maintain insurance coverage of such types and with such terms and limits as described in this Agreement. The Grantee shall require all its sub-grantees and/or subcontractors, if any, to make compliance with the insurance requirements of this Agreement a condition of all contracts that are related to this Agreement. Sub-grantees and/or subcontractors must provide proof of insurance upon request.
- b. Deductibles. The Department shall be exempt from, and in no way liable for, any sums of money representing a deductible in any insurance policy. The payment of such deductible shall be the sole responsibility of the Grantee providing such insurance.
- c. Proof of Insurance. Upon execution of this Agreement, Grantee shall provide Department documentation demonstrating the existence and amount for each type of applicable insurance coverage *prior to* performance of any work under this Agreement. Upon receipt of written request from Department, Grantee shall furnish Department with proof of applicable insurance coverage by standard form certificates of insurance, a self-insured authorization, or other certification of self-insurance.
- d. Duty to Maintain Coverage. In the event that any applicable coverage is cancelled by the insurer for any reason, or if Grantee cannot get adequate coverage, Grantee shall immediately notify Department of such cancellation and shall obtain adequate replacement coverage conforming to the requirements herein and provide proof of such replacement coverage within ten (10) days after the cancellation of coverage.

13. Termination.

- a. Termination for Convenience. When it is in the State's best interest, Department may, at its sole discretion, terminate the Agreement in whole or in part by giving 30 days' written notice to Grantee. The Department shall notify Grantee of the termination for convenience with instructions as to the effective date of termination or the specific stage of work at which the Agreement is to be terminated. The Department must submit all invoices for work to be paid under this Agreement within thirty (30) days of the effective date of termination. The Department shall not pay any invoices received after thirty (30) days of the effective date of termination.
- b. Termination for Cause. The Department may terminate this Agreement if any of the events of default described in the Events of Default provisions below occur or in the event that Grantee fails to fulfill any of its other obligations under this Agreement. If, after termination, it is determined that Grantee was not in default, or that the default was excusable, the rights and obligations of the parties shall be the same as if the termination had been issued for the convenience of Department. The rights and remedies of Department in this clause are in addition to any other rights and remedies provided by law or under this Agreement.
- c. Grantee Obligations upon Notice of Termination. After receipt of a notice of termination or partial termination unless as otherwise directed by Department, Grantee shall not furnish any service or deliverable on the date, and to the extent specified, in the notice. However, Grantee shall continue work on any portion of the Agreement not terminated. If the Agreement is terminated before performance is completed, Grantee shall be paid only for that work satisfactorily performed for which costs can be substantiated. The Grantee shall not be entitled to recover any cancellation charges or lost profits.
- d. Continuation of Prepaid Services. If Department has paid for any services prior to the expiration, cancellation, or termination of the Agreement, Grantee shall continue to provide Department with those services for which it

has already been paid or, at Department's discretion, Grantee shall provide a refund for services that have been paid for but not rendered.

- e. Transition of Services Upon Termination, Expiration, or Cancellation of the Agreement. If services provided under the Agreement are being transitioned to another provider(s), Grantee shall assist in the smooth transition of Agreement services to the subsequent provider(s). This requirement is at a minimum an affirmative obligation to cooperate with the new provider(s), however additional requirements may be outlined in the Grant Work Plan. The Grantee shall not perform any services after Agreement expiration or termination, except as necessary to complete the transition or continued portion of the Agreement, if any.

14. Notice of Default.

If Grantee defaults in the performance of any covenant or obligation contained in the Agreement, including, any of the events of default, Department shall provide notice to Grantee and an opportunity to cure that is reasonable under the circumstances. This notice shall state the nature of the failure to perform and provide a time certain for correcting the failure. The notice will also provide that, should the Grantee fail to perform within the time provided, Grantee will be found in default, and Department may terminate the Agreement effective as of the date of receipt of the default notice.

15. Events of Default.

Provided such failure is not the fault of Department or outside the reasonable control of Grantee, the following non-exclusive list of events, acts, or omissions, shall constitute events of default:

- a. The commitment of any material breach of this Agreement by Grantee, including failure to timely deliver a material deliverable, failure to perform the minimal level of services required for a deliverable, discontinuance of the performance of the work, failure to resume work that has been discontinued within a reasonable time after notice to do so, or abandonment of the Agreement;
- b. The commitment of any material misrepresentation or omission in any materials, or discovery by the Department of such, made by the Grantee in this Agreement or in its application for funding;
- c. Failure to submit any of the reports required by this Agreement or having submitted any report with incorrect, incomplete, or insufficient information;
- d. Failure to honor any term of the Agreement;
- e. Failure to abide by any statutory, regulatory, or licensing requirement, including an entry of an order revoking the certificate of authority granted to the Grantee by a state or other licensing authority;
- f. Failure to pay any and all entities, individuals, and furnishing labor or materials, or failure to make payment to any other entities as required by this Agreement;
- g. Employment of an unauthorized alien in the performance of the work, in violation of Section 274 (A) of the Immigration and Nationality Act;
- h. Failure to maintain the insurance required by this Agreement;
- i. One or more of the following circumstances, uncorrected for more than thirty (30) days unless, within the specified 30-day period, Grantee (including its receiver or trustee in bankruptcy) provides to Department adequate assurances, reasonably acceptable to Department, of its continuing ability and willingness to fulfill its obligations under the Agreement:
 - i. Entry of an order for relief under Title 11 of the United States Code;
 - ii. The making by Grantee of a general assignment for the benefit of creditors;
 - iii. The appointment of a general receiver or trustee in bankruptcy of Grantee's business or property; and/or
 - iv. An action by Grantee under any state insolvency or similar law for the purpose of its bankruptcy, reorganization, or liquidation.

16. Suspension of Work.

The Department may, in its sole discretion, suspend any or all activities under the Agreement, at any time, when it is in the best interest of the State to do so. The Department shall provide Grantee written notice outlining the particulars of suspension. Examples of reasons for suspension include, but are not limited to, budgetary constraints, declaration of emergency, or other such circumstances. After receiving a suspension notice, Grantee shall comply with the notice. Within 90 days, or any longer period agreed to by the parties, Department shall either: (1) issue a notice authorizing resumption of work, at which time activity shall resume; or (2) terminate the Agreement. If the Agreement is terminated after 30 days of suspension, the notice of suspension shall be deemed to satisfy the thirty (30) days' notice required for a notice of termination for convenience. Suspension of work shall not entitle Grantee to any additional compensation.

17. Force Majeure.

The Grantee shall not be responsible for delay resulting from its failure to perform if neither the fault nor the negligence of Grantee or its employees or agents contributed to the delay and the delay is due directly to acts of God, wars, acts of public enemies, strikes, fires, floods, or other similar cause wholly beyond Grantee's control, or for any of the foregoing that affect subcontractors or suppliers if no alternate source of supply is available to Grantee. In case of any delay Grantee believes is excusable, Grantee shall notify Department in writing of the delay or potential delay and describe the cause of the delay either (1) within ten days after the cause that creates or will create the delay first arose, if Grantee could reasonably foresee that a delay could occur as a result; or (2) if delay is not reasonably foreseeable, within five days after the date Grantee first had reason to believe that a delay could result. **THE FOREGOING SHALL CONSTITUTE THE GRANTEE'S SOLE REMEDY OR EXCUSE WITH RESPECT TO DELAY.** Providing notice in strict accordance with this paragraph is a condition precedent to such remedy. No claim for damages, other than for an extension of time, shall be asserted against Department. The Grantee shall not be entitled to an increase in the Agreement price or payment of any kind from Department for direct, indirect, consequential, impact or other costs, expenses or damages, including but not limited to costs of acceleration or inefficiency, arising because of delay, disruption, interference, or hindrance from any cause whatsoever. If performance is suspended or delayed, in whole or in part, due to any of the causes described in this paragraph, after the causes have ceased to exist Grantee shall perform at no increased cost, unless Department determines, in its sole discretion, that the delay will significantly impair the value of the Agreement to Department, in which case Department may: (1) accept allocated performance or deliveries from Grantee, provided that Grantee grants preferential treatment to Department with respect to products subjected to allocation; (2) contract with other sources (without recourse to and by Grantee for the related costs and expenses) to replace all or part of the products or services that are the subject of the delay, which purchases may be deducted from the Agreement quantity; or (3) terminate Agreement in whole or in part.

18. Indemnification.

- a. The Grantee shall be fully liable for the actions of its agents, employees, partners, or subcontractors and shall fully indemnify, defend, and hold harmless Department and its officers, agents, and employees, from suits, actions, damages, and costs of every name and description arising from or relating to:
 - i. personal injury and damage to real or personal tangible property alleged to be caused in whole or in part by Grantee, its agents, employees, partners, or subcontractors; provided, however, that Grantee shall not indemnify for that portion of any loss or damages proximately caused by the negligent act or omission of Department;
 - ii. the Grantee's breach of this Agreement or the negligent acts or omissions of Grantee.
- b. The Grantee's obligations under the preceding paragraph with respect to any legal action are contingent upon Department giving Grantee: (1) written notice of any action or threatened action; (2) the opportunity to take over and settle or defend any such action at Grantee's sole expense; and (3) assistance in defending the action at Grantee's sole expense. The Grantee shall not be liable for any cost, expense, or compromise incurred or made by Department in any legal action without Grantee's prior written consent, which shall not be unreasonably withheld.
- c. Notwithstanding sections a. and b. above, the following is the sole indemnification provision that applies to Grantees that are governmental entities: Each party hereto agrees that it shall be solely responsible for the negligent or wrongful acts of its employees and agents. However, nothing contained herein shall constitute a waiver by either party of its sovereign immunity or the provisions of Section 768.28, F.S. Further, nothing herein shall be construed as consent by a state agency or subdivision of the State to be sued by third parties in any matter arising out of any contract or this Agreement.
- d. No provision in this Agreement shall require Department to hold harmless or indemnify Grantee, insure or assume liability for Grantee's negligence, waive Department's sovereign immunity under the laws of Florida, or otherwise impose liability on Department for which it would not otherwise be responsible. Any provision, implication or suggestion to the contrary is null and void.

19. Limitation of Liability.

The Department's liability for any claim arising from this Agreement is limited to compensatory damages in an amount no greater than the sum of the unpaid balance of compensation due for goods or services rendered pursuant to and in compliance with the terms of the Agreement. Such liability is further limited to a cap of \$100,000.

20. Remedies.

Nothing in this Agreement shall be construed to make Grantee liable for force majeure events. Nothing in this Agreement, including financial consequences for nonperformance, shall limit Department's right to pursue its remedies for other types of damages under the Agreement, at law or in equity. The Department may, in addition to

other remedies available to it, at law or in equity and upon notice to Grantee, retain such monies from amounts due Grantee as may be necessary to satisfy any claim for damages, penalties, costs and the like asserted by or against it.

21. Waiver.

The delay or failure by Department to exercise or enforce any of its rights under this Agreement shall not constitute or be deemed a waiver of Department's right thereafter to enforce those rights, nor shall any single or partial exercise of any such right preclude any other or further exercise thereof or the exercise of any other right.

22. Statutory Notices Relating to Unauthorized Employment and Subcontracts.

- a. The Department shall consider the employment by any Grantee of unauthorized aliens a violation of Section 274A(e) of the Immigration and Nationality Act. If Grantee/subcontractor knowingly employs unauthorized aliens, such violation shall be cause for unilateral cancellation of this Agreement. The Grantee shall be responsible for including this provision in all subcontracts with private organizations issued as a result of this Agreement.
- b. Pursuant to Sections 287.133 and 287.134, F.S., the following restrictions apply to persons placed on the convicted vendor list or the discriminatory vendor list:
 - i. Public Entity Crime. A person or affiliate who has been placed on the convicted vendor list following a conviction for a public entity crime may not submit a bid, proposal, or reply on a contract to provide any goods or services to a public entity; may not submit a bid, proposal, or reply on a contract with a public entity for the construction or repair of a public building or public work; may not submit bids, proposals, or replies on leases of real property to a public entity; may not be awarded or perform work as a Grantee, supplier, subcontractor, or consultant under a contract with any public entity; and may not transact business with any public entity in excess of the threshold amount provided in Section 287.017, F.S., for CATEGORY TWO for a period of 36 months following the date of being placed on the convicted vendor list.
 - ii. Discriminatory Vendors. An entity or affiliate who has been placed on the discriminatory vendor list may not submit a bid, proposal, or reply on a contract to provide any goods or services to a public entity; may not submit a bid, proposal, or reply on a contract with a public entity for the construction or repair of a public building or public work; may not submit bids, proposals, or replies on leases of real property to a public entity; may not be awarded or perform work as a contractor, supplier, subcontractor, or consultant under a contract with any public entity; and may not transact business with any public entity.
 - iii. Notification. The Grantee shall notify Department if it or any of its suppliers, subcontractors, or consultants have been placed on the convicted vendor list or the discriminatory vendor list during the life of the Agreement. The Florida Department of Management Services is responsible for maintaining the discriminatory vendor list and posts the list on its website. Questions regarding the discriminatory vendor list may be directed to the Florida Department of Management Services, Office of Supplier Diversity, at (850) 487-0915.

23. Compliance with Federal, State and Local Laws.

- a. The Grantee and all its agents shall comply with all federal, state and local regulations, including, but not limited to, nondiscrimination, wages, social security, workers' compensation, licenses, and registration requirements. The Grantee shall include this provision in all subcontracts issued as a result of this Agreement.
- b. No person, on the grounds of race, creed, color, religion, national origin, age, gender, or disability, shall be excluded from participation in; be denied the proceeds or benefits of; or be otherwise subjected to discrimination in performance of this Agreement.
- c. This Agreement shall be governed by and construed in accordance with the laws of the State of Florida.
- d. Any dispute concerning performance of the Agreement shall be processed as described herein. Jurisdiction for any damages arising under the terms of the Agreement will be in the courts of the State, and venue will be in the Second Judicial Circuit, in and for Leon County. Except as otherwise provided by law, the parties agree to be responsible for their own attorney fees incurred in connection with disputes arising under the terms of this Agreement.

24. Scrutinized Companies.

- a. Grantee certifies that it is not on the Scrutinized Companies that Boycott Israel List or engaged in a boycott of Israel. Pursuant to Section 287.135, F.S., the Department may immediately terminate this Agreement at its sole option if the Grantee is found to have submitted a false certification; or if the Grantee is placed on the Scrutinized Companies that Boycott Israel List or is engaged in the boycott of Israel during the term of the Agreement.
- b. If this Agreement is for more than one million dollars, the Grantee certifies that it is also not on the Scrutinized Companies with Activities in Sudan, Scrutinized Companies with Activities in the Iran Petroleum Energy Sector List, or engaged with business operations in Cuba or Syria as identified in Section 287.135, F.S. Pursuant to

Section 287.135, F.S., the Department may immediately terminate this Agreement at its sole option if the Grantee is found to have submitted a false certification; or if the Grantee is placed on the Scrutinized Companies with Activities in Sudan List, or Scrutinized Companies with Activities in the Iran Petroleum Energy Sector List, or engaged with business operations in Cuba or Syria during the term of the Agreement.

- c. As provided in Subsection 287.135(8), F.S., if federal law ceases to authorize these contracting prohibitions then they shall become inoperative.

25. Lobbying and Integrity.

The Grantee agrees that no funds received by it under this Agreement will be expended for the purpose of lobbying the Legislature or a State agency pursuant to Section 216.347, F.S., except that pursuant to the requirements of Section 287.058(6), F.S., during the term of any executed agreement between Grantee and the State, Grantee may lobby the executive or legislative branch concerning the scope of services, performance, term, or compensation regarding that agreement. The Grantee shall comply with Sections 11.062 and 216.347, F.S.

26. Record Keeping.

The Grantee shall maintain books, records and documents directly pertinent to performance under this Agreement in accordance with United States generally accepted accounting principles (US GAAP) consistently applied. The Department, the State, or their authorized representatives shall have access to such records for audit purposes during the term of this Agreement and for five (5) years following the completion date or termination of the Agreement. In the event that any work is subcontracted, Grantee shall similarly require each subcontractor to maintain and allow access to such records for audit purposes. Upon request of Department's Inspector General, or other authorized State official, Grantee shall provide any type of information the Inspector General deems relevant to Grantee's integrity or responsibility. Such information may include, but shall not be limited to, Grantee's business or financial records, documents, or files of any type or form that refer to or relate to Agreement. The Grantee shall retain such records for the longer of: (1) three years after the expiration of the Agreement; or (2) the period required by the General Records Schedules maintained by the Florida Department of State (available at: <http://dos.myflorida.com/library-archives/records-management/general-records-schedules/>).

27. Audits.

- a. Inspector General. The Grantee understands its duty, pursuant to Section 20.055(5), F.S., to cooperate with the inspector general in any investigation, audit, inspection, review, or hearing. The Grantee will comply with this duty and ensure that its sub-grantees and/or subcontractors issued under this Agreement, if any, impose this requirement, in writing, on its sub-grantees and/or subcontractors, respectively.
- b. Physical Access and Inspection. Department personnel shall be given access to and may observe and inspect work being performed under this Agreement, with reasonable notice and during normal business hours, including by any of the following methods:
 - i. Grantee shall provide access to any location or facility on which Grantee is performing work, or storing or staging equipment, materials or documents;
 - ii. Grantee shall permit inspection of any facility, equipment, practices, or operations required in performance of any work pursuant to this Agreement; and,
 - iii. Grantee shall allow and facilitate sampling and monitoring of any substances, soils, materials or parameters at any location reasonable or necessary to assure compliance with any work or legal requirements pursuant to this Agreement.
- c. Special Audit Requirements. The Grantee shall comply with the applicable provisions contained in Attachment 5, Special Audit Requirements. Each amendment that authorizes a funding increase or decrease shall include an updated copy of Exhibit 1, to Attachment 5. If Department fails to provide an updated copy of Exhibit 1 to include in each amendment that authorizes a funding increase or decrease, Grantee shall request one from the Department's Grants Manager. The Grantee shall consider the type of financial assistance (federal and/or state) identified in Attachment 5, Exhibit 1 and determine whether the terms of Federal and/or Florida Single Audit Act Requirements may further apply to lower tier transactions that may be a result of this Agreement. For federal financial assistance, Grantee shall utilize the guidance provided under 2 CFR §200.330 for determining whether the relationship represents that of a subrecipient or vendor. For State financial assistance, Grantee shall utilize the form entitled "Checklist for Nonstate Organizations Recipient/Subrecipient vs Vendor Determination" (form number DFS-A2-NS) that can be found under the "Links/Forms" section appearing at the following website: <https://apps.fldfs.com/ksaa>.
- d. Proof of Transactions. In addition to documentation provided to support cost reimbursement as described herein, Department may periodically request additional proof of a transaction to evaluate the appropriateness of costs to the Agreement pursuant to State and Federal guidelines (including cost allocation guidelines). Allowable costs and uniform administrative requirements for federal programs can be found under 2 CFR 200. The Department

may also request a cost allocation plan in support of its multipliers (overhead, indirect, general administrative costs, and fringe benefits). The Grantee must provide the additional proof within thirty (30) days of such request.

- e. **No Commingling of Funds.** The accounting systems for all Grantees must ensure that these funds are not commingled with funds from other agencies. Funds from each agency must be accounted for separately. Grantees are prohibited from commingling funds on either a program-by-program or a project-by-project basis. Funds specifically budgeted and/or received for one project may not be used to support another project. Where a Grantee's, or subrecipient's, accounting system cannot comply with this requirement, Grantee, or subrecipient, shall establish a system to provide adequate fund accountability for each project it has been awarded.
- i. If Department finds that these funds have been commingled, Department shall have the right to demand a refund, either in whole or in part, of the funds provided to Grantee under this Agreement for non-compliance with the material terms of this Agreement. The Grantee, upon such written notification from Department shall refund, and shall forthwith pay to Department, the amount of money demanded by Department. Interest on any refund shall be calculated based on the prevailing rate used by the State Board of Administration. Interest shall be calculated from the date(s) the original payment(s) are received from Department by Grantee to the date repayment is made by Grantee to Department.
 - ii. In the event that the Grantee recovers costs, incurred under this Agreement and reimbursed by Department, from another source(s), Grantee shall reimburse Department for all recovered funds originally provided under this Agreement and interest shall be charged for those recovered costs as calculated on from the date(s) the payment(s) are recovered by Grantee to the date repayment is made to Department.
 - iii. Notwithstanding the requirements of this section, the above restrictions on commingling funds do not apply to agreements where payments are made purely on a cost reimbursement basis.

28. Conflict of Interest.

The Grantee covenants that it presently has no interest and shall not acquire any interest which would conflict in any manner or degree with the performance of services required.

29. Independent Contractor.

The Grantee is an independent contractor and is not an employee or agent of Department.

30. Subcontracting.

- a. Unless otherwise specified in the Special Terms and Conditions, all services contracted for are to be performed solely by Grantee.
- b. The Department may, for cause, require the replacement of any Grantee employee, subcontractor, or agent. For cause, includes, but is not limited to, technical or training qualifications, quality of work, change in security status, or non-compliance with an applicable Department policy or other requirement.
- c. The Department may, for cause, deny access to Department's secure information or any facility by any Grantee employee, subcontractor, or agent.
- d. The Department's actions under paragraphs b. or c. shall not relieve Grantee of its obligation to perform all work in compliance with the Agreement. The Grantee shall be responsible for the payment of all monies due under any subcontract. The Department shall not be liable to any subcontractor for any expenses or liabilities incurred under any subcontract and Grantee shall be solely liable to the subcontractor for all expenses and liabilities incurred under any subcontract.
- e. The Department will not deny Grantee's employees, subcontractors, or agents access to meetings within the Department's facilities, unless the basis of Department's denial is safety or security considerations.
- f. The Department supports diversity in its procurement program and requests that all subcontracting opportunities afforded by this Agreement embrace diversity enthusiastically. The award of subcontracts should reflect the full diversity of the citizens of the State. A list of minority-owned firms that could be offered subcontracting opportunities may be obtained by contacting the Office of Supplier Diversity at (850) 487-0915.
- g. The Grantee shall not be liable for any excess costs for a failure to perform, if the failure to perform is caused by the default of a subcontractor at any tier, and if the cause of the default is completely beyond the control of both Grantee and the subcontractor(s), and without the fault or negligence of either, unless the subcontracted products or services were obtainable from other sources in sufficient time for Grantee to meet the required delivery schedule.

31. Guarantee of Parent Company.

If Grantee is a subsidiary of another corporation or other business entity, Grantee asserts that its parent company will guarantee all of the obligations of Grantee for purposes of fulfilling the obligations of Agreement. In the event Grantee

is sold during the period the Agreement is in effect, Grantee agrees that it will be a requirement of sale that the new parent company guarantee all of the obligations of Grantee.

32. Survival.

The respective obligations of the parties, which by their nature would continue beyond the termination or expiration of this Agreement, including without limitation, the obligations regarding confidentiality, proprietary interests, and public records, shall survive termination, cancellation, or expiration of this Agreement.

33. Third Parties.

The Department shall not be deemed to assume any liability for the acts, failures to act or negligence of Grantee, its agents, servants, and employees, nor shall Grantee disclaim its own negligence to Department or any third party. This Agreement does not and is not intended to confer any rights or remedies upon any person other than the parties. If Department consents to a subcontract, Grantee will specifically disclose that this Agreement does not create any third-party rights. Further, no third parties shall rely upon any of the rights and obligations created under this Agreement.

34. Severability.

If a court of competent jurisdiction deems any term or condition herein void or unenforceable, the other provisions are severable to that void provision, and shall remain in full force and effect.

35. Grantee's Employees, Subcontractors and Agents.

All Grantee employees, subcontractors, or agents performing work under the Agreement shall be properly trained technicians who meet or exceed any specified training qualifications. Upon request, Grantee shall furnish a copy of technical certification or other proof of qualification. All employees, subcontractors, or agents performing work under Agreement must comply with all security and administrative requirements of Department and shall comply with all controlling laws and regulations relevant to the services they are providing under the Agreement.

36. Assignment.

The Grantee shall not sell, assign, or transfer any of its rights, duties, or obligations under the Agreement, or under any purchase order issued pursuant to the Agreement, without the prior written consent of Department. In the event of any assignment, Grantee remains secondarily liable for performance of the Agreement, unless Department expressly waives such secondary liability. The Department may assign the Agreement with prior written notice to Grantee of its intent to do so.

37. Execution in Counterparts and Authority to Sign.

This Agreement, any amendments, and/or change orders related to the Agreement, may be executed in counterparts, each of which shall be an original and all of which shall constitute the same instrument. In accordance with the Electronic Signature Act of 1996, electronic signatures, including facsimile transmissions, may be used and shall have the same force and effect as a written signature. Each person signing this Agreement warrants that he or she is duly authorized to do so and to bind the respective party to the Agreement.

STATE OF FLORIDA
DEPARTMENT OF ENVIRONMENTAL PROTECTION
Special Terms and Conditions
AGREEMENT NO. LW695

ATTACHMENT 2

These Special Terms and Conditions shall be read together with general terms outlined in the Standard Terms and Conditions, Attachment 1. Where in conflict, these more specific terms shall apply.

1. Scope of Work.

The Project funded under this Agreement is Hallstrom Farmstead Conservation Area Improvements. The Project is defined in more detail in Attachment 3, Grant Work Plan.

2. Duration.

- a. Reimbursement Period. The reimbursement period for this Agreement begins on or after September 24, 2018, through May 31, 2022, which shall be defined as the Project Completion Date. All work, eligible for reimbursement under this Agreement, must be completed by the Project Completion Date.
- b. Extensions. There are extensions available for this Project.
- c. Service Periods. Additional service periods are not authorized under this Agreement.

3. Payment Provisions.

- a. Compensation. This is a cost reimbursement Agreement. The Grantee shall be compensated under this Agreement as described in Attachment 3.
- b. Invoicing. Invoicing will occur after approval of the final deliverable(s).
- c. Advance Pay. Advance Pay is not authorized under this Agreement.

4. Cost Eligible for Reimbursement or Matching Requirements.

Reimbursement for costs or availability for costs to meet matching requirements shall be limited to the following budget categories, as defined in the Reference Guide for State Expenditures, as indicated:

<u>Reimbursement</u>	<u>Match</u>	<u>Category</u>
<input checked="" type="checkbox"/>	<input checked="" type="checkbox"/>	Salaries/Wages
		Overhead/Indirect/General and Administrative Costs:
<input checked="" type="checkbox"/>	<input checked="" type="checkbox"/>	a. Fringe Benefits, N/A.
<input checked="" type="checkbox"/>	<input checked="" type="checkbox"/>	b. Indirect Costs, N/A.
<input checked="" type="checkbox"/>	<input checked="" type="checkbox"/>	Contractual (Subcontractors)
<input type="checkbox"/>	<input type="checkbox"/>	Travel
<input type="checkbox"/>	<input type="checkbox"/>	Equipment
<input checked="" type="checkbox"/>	<input checked="" type="checkbox"/>	Rental/Lease of Equipment
<input checked="" type="checkbox"/>	<input checked="" type="checkbox"/>	Miscellaneous/Other Expenses
<input type="checkbox"/>	<input type="checkbox"/>	Land Acquisition

5. Travel.

Additional compensation for travel is not authorized under this Agreement.

6. Equipment Purchase.

No Equipment purchases shall be funded under this Agreement.

7. Land Acquisition.

There will be no Land Acquisitions funded under this Agreement.

8. Match Requirements

This Agreement requires at least a fifty percent (50%) non-federal match from the Grantee towards the work funded under this Agreement. Therefore, the Grantee is responsible for providing \$148,500.00 towards the Project funded

under this Agreement. It is understood that any additional funds necessary for the completion of this project are the responsibility of the Grantee.

All required matching funds shall meet the federal requirements established in 2 CFR § 200.306 and other federal statutory requirements, as applicable. Grantee acknowledges and agrees to provide eligible match types as set forth in the LWCF Federal Financial Assistance Manual <https://www.nps.gov/subjects/lwcf/lwcf-manual.htm>. Grantee acknowledges and agrees not to provide ineligible match sources, including real property acquired or funds obtained from any of the following sources:

- a. Florida Recreation Development Assistance Program (FRDAP), Recreation Trails Program (RTP), and LWCF;
- b. Donated value of real property acquired prior to Department approval or through Land and Water Conservation Fund; and
- c. Other state or federal grant or land acquisition programs such as: legislative special interest projects, Save Our Coast Program, Preservation 2000, Florida Forever, Conservation and Recreation Lands Program, Save Our Rivers Program, and Land Acquisition Trust Fund.

Real property donated as all, or part of the Grantee's required match must be appraised prior to commencement of the Project. Pursuant to subsection 62D-5.071(9), F.A.C., the Grantee shall submit appraisal(s), obtained at its own expense and prepared in accordance with the Uniform Appraisal Standards for Federal Land Acquisitions ("UASFLA"). The appraisal must establish the fair market value of the Project site. Property appraised at \$500,000 or less requires one (1) appraisal. Property exceeding \$500,000 in appraised value requires a second appraisal. The appraisal(s) shall be dated no earlier than six (6) months prior to the closing date of the LWCF application submission period. The appraisal must be prepared by an appraiser on the list of approved appraisers maintained by the Department's Division of State Lands under the provisions of Sections 253.025(6)(b), 259.041(7)(c), F.S., and Rule 18-1.007, F.A.C. Property value is based on the purchase price or appraised value, whichever is lower; if two (2) appraisals are required, the property value is lowest of the two appraisals or the purchase price. Appraisal costs shall not be reimbursed under the terms and conditions of this Agreement. If the negotiated purchase price or approved appraised value is greater than the annual appropriation by USDOJ, NPS and the Florida Legislature, the Grantee must pay the additional cost.

9. Insurance Requirements

Required Coverage. At all times during the Agreement the Grantee, at its sole expense, shall maintain insurance coverage of such types and with such terms and limits described below. The limits of coverage under each policy maintained by the Grantee shall not be interpreted as limiting the Grantee's liability and obligations under the Agreement. All insurance policies shall be through insurers licensed and authorized to issue policies in Florida, or alternatively, Grantee may provide coverage through a self-insurance program established and operating under the laws of Florida. Additional insurance requirements for this Agreement may be required elsewhere in this Agreement, however the minimum insurance requirements applicable to this Agreement are:

- a. **Commercial General Liability Insurance.**
The Grantee shall provide adequate commercial general liability insurance coverage and hold such liability insurance at all times during the Agreement. The Department, its employees, and officers shall be named as an additional insured on any general liability policies. The minimum limits shall be \$250,000 for each occurrence and \$500,000 policy aggregate.
- b. **Commercial Automobile Insurance.**
If the Grantee's duties include the use of a commercial vehicle, the Grantee shall maintain automobile liability, bodily injury, and property damage coverage. Insuring clauses for both bodily injury and property damage shall provide coverage on an occurrence basis. The Department, its employees, and officers shall be named as an additional insured on any automobile insurance policy. The minimum limits shall be as follows:

\$200,000/300,000	Automobile Liability for Company-Owned Vehicles, if applicable
\$200,000/300,000	Hired and Non-owned Automobile Liability Coverage
- c. **Workers' Compensation and Employer's Liability Coverage.**
The Grantee shall provide workers' compensation, in accordance with Chapter 440, F.S., and employer's liability insurance with minimum limits of \$100,000 per accident, \$100,000 per person, and \$500,000 policy aggregate. Such policies shall cover all employees engaged in any work under the Agreement.
- d. **Other Insurance.** None.

10. Quality Assurance Requirements.

There are no special Quality Assurance requirements under this Agreement.

11. Retainage.

Retainage is permitted under this Agreement. Retainage may be up to a maximum of ten percent (10%) of the total amount of the Agreement.

12. Subcontracting.

The Grantee may subcontract work under this Agreement without the prior written consent of the Department's Grant Manager except for certain fixed-price subcontracts pursuant to this Agreement, which require prior approval. The Grantee shall submit a copy of the executed subcontract to the Department prior to submitting any invoices for subcontracted work. Regardless of any subcontract, the Grantee is ultimately responsible for all work to be performed under this Agreement.

13. State-owned Land.

The work will not be performed on State-owned land.

14. Office of Policy and Budget Reporting.

There are no special Office of Policy and Budget reporting requirements for this Agreement.

15. Additional Terms.

None.

ATTACHMENT 3
GRANT WORK PLAN
LAND AND WATER CONSERVATION FUND PROGRAM (LWCF)
 Project Name: Hallstrom Farmstead Conservation Area Improvements
 Grantee Name: Indian River County
 LWCF Project # LW695

SUMMARY: The Grantee shall complete the Project Element(s), which were approved by the Department through the LWCF Application Evaluation Criteria, pursuant to Chapter 62D-5, Florida Administrative Code (F.A.C.). Any alteration(s) to the Project Element(s) as identified in the Grant Work Plan resulting in a change in the total point score of Grantee's Application as it appears on the Recommended Application Priority List for FY17/18 is considered a significant change and must be pre-approved by the Department and requires a formal Amendment to this Agreement. All work must be completed in accordance with the LWCF Program, and local, state and federal laws, the approved Project plans, all required permits, and the Florida Building Code. Prior to the Department issuing a "Notice to Commence" to the Grantee, as specified in Attachment 6 of the Agreement, Program Specific Requirements, the Department must receive evidence of and have approved all Deliverables in Task 1.

For the purpose of this Agreement, the terms "Project Element" and "Project Task" are used interchangeably to mean an identified facility within the Project.

The Project is located at 1601 Old Dixie Highway SW, Vero Beach, FL 32962 and is considered a "Development Project" pursuant to subsection 62D-5.070(5)(b), F.A.C.

Project Completion: The Project Completion Date for this Agreement is May 31, 2022.

Budget: Reimbursement for allowable costs for the Project shall not exceed the maximum Grant Award Amount outlined below. Required match for development projects will be provided by cash, in-kind services, or donated real property, as set forth in subparagraph 62D-5.070(6)(b)1., F.A.C. Required match for acquisition projects will be provided by cash or real property donated, as set forth in subparagraph 62D-5.070(6)(b)2., F.A.C. The total estimated Project cost provided below is based on the approved LWCF Application. A detailed cost analysis will be provided in the Deliverables for Task 1, prior to the Department issuing the "Notice to Commence." All final Project Costs shall be submitted to the Department with the payment request.

Maximum Grant Award Amount:	\$148,500.00
Required Grantee Match Amount:	\$148,500.00
Total Estimated Project Cost:	\$297,000.00
Match Ratio:	50%

Scope of Work/Tasks	Deliverables	Due Date	Financial Consequences
TASK 1 1.A. Development of Commencement Documentation Checklist (DRP-122) ¹ . 1.B. A Cost Analysis Form, with detailed budget (and In-House Cost Schedule(s), if applicable).	DELIVERABLE 1 The Department will issue "Notice to Commence" upon receipt and approval of: 1.A. All applicable Project specific Commencement documentation listed on Commencement Documentation Checklist (DRP-122) 1.B. A Cost Analysis Form, with detailed budget (and In-House Cost Schedule(s), if applicable). Project planning expenses, such as application preparation, architectural and engineering fees, permitting fees, Project	180 calendar days after Execution of Agreement ²	The Department shall terminate the Project Agreement if the required Deliverables are not submitted and approved by the Department.

	inspection, and other similar fees are eligible for reimbursement. However, reimbursement, if requested, shall not exceed fifteen (15%) of total Project cost, and shall be invoiced upon Project completion, in accordance with the Payment Request Schedule. The Grantee may not proceed with development of the Project until Notice to Commence has been issued.		
TASK 2 2.A. Development of Primary and Support Project Elements, which includes: Install a 30' x 30' pavilion with concrete floor (includes survey, earthwork and construction), a 24' x 24' pavilion/outdoor classroom with stabilized pervious base floor (includes survey, earthwork and construction); Survey and construct a boardwalk; Create a .3 mile ADA accessible loop trail and a 1.1 mile nature trail; Construct a parking area. 2.B. Development of Completion of Documentation Checklist (DRP-125). 2.C. Completion of Final Status Report (DRP-109).	DELIVERABLE 2 The Grantee may request reimbursement upon Department receipt and approval of: 2.A. Development of required Project Elements. 2.B. All applicable Project specific Completion documentation listed on Completion Documentation Checklist (DRP-125) 2.C. Final Status Report (DRP-109). The Grantee may request reimbursement for allowable budgeted expenses and costs pursuant to the Agreement that are directly related to the successful development of the Project site. Reimbursement shall not exceed the Grant Award Amount, less any reimbursement requested for in Deliverable 1, and shall be invoiced upon Project completion, in accordance with the Payment Request Schedule below. Ten percent (10%) of the Grant Award will be retained until the Project is designated complete by the Department.	Due May 31, 2022, which shall also be the Project Completion Date ³	No reimbursement will be made for Deliverable(s) deemed unsatisfactory by the Department. Payment(s) will not be made for unsatisfactory or incomplete work. In addition, a Task may be terminated for Grantee's failure to perform.

Project Task Performance Standard: The Department's Grant Manager will review the Project Completion Certificate and the Deliverables to verify compliance with the requirements for funding under LWCF; approved plans and application approved for funding. Upon review and written acceptance by the Department's Grant Manager of the Project Completion Certificate and the Deliverables under each Project Task, the Grantee may proceed with the payment request submittal.

Payment Request Schedule: Following Department approval of all Deliverables, the Grantee may submit a single payment request on Exhibit C, Payment Request Summary Form, DRP-115, along with all required documentation as outlined in the Financial Reporting Procedures (DRP-110), as applicable, to support payment. A payment request submitted as part of the reimbursement process must correspond with the Cost Analysis and supporting documents provided under Project Tasks.

Endnotes:

1. LWCF documentation is available at <https://floridadep.gov/lands/land-and-recreation-grants/content/land-and-water-conservation-fund-program> and/or from the Land and Recreational Grants Section, State of Florida Department of Environmental Protection, 3900 Commonwealth Boulevard, MS# 585, Tallahassee, Florida, 32399-3000.
2. Project Agreement is subject to termination if Commencement documentations under Task 1 are not received and approved by the Department within 180 calendar days of the Project Agreement execution.
3. Due Date will not be extended beyond the Grant Period as outlined in Rule 62D-5.073, F.A.C.

STATE OF FLORIDA
DEPARTMENT OF ENVIRONMENTAL PROTECTION
Public Records Requirements

Attachment 4

1. Public Records.

- a. If the Agreement exceeds \$35,000.00, and if Grantee is acting on behalf of Department in its performance of services under the Agreement, Grantee must allow public access to all documents, papers, letters, or other material, regardless of the physical form, characteristics, or means of transmission, made or received by Grantee in conjunction with the Agreement (Public Records), unless the Public Records are exempt from section 24(a) of Article I of the Florida Constitution or section 119.07(1), F.S.
- b. The Department may unilaterally terminate the Agreement if Grantee refuses to allow public access to Public Records as required by law.

2. Additional Public Records Duties of Section 119.0701, F.S., If Applicable.

For the purposes of this paragraph, the term "contract" means the "Agreement." If Grantee is a "contractor" as defined in section 119.0701(1)(a), F.S., the following provisions apply and the contractor shall:

- a. Keep and maintain Public Records required by Department to perform the service.
- b. Upon request, provide Department with a copy of requested Public Records or allow the Public Records to be inspected or copied within a reasonable time at a cost that does not exceed the cost provided in Chapter 119, F.S., or as otherwise provided by law.
- c. A contractor who fails to provide the Public Records to Department within a reasonable time may be subject to penalties under section 119.10, F.S.
- d. Ensure that Public Records that are exempt or confidential and exempt from Public Records disclosure requirements are not disclosed except as authorized by law for the duration of the contract term and following completion of the contract if the contractor does not transfer the Public Records to Department.
- e. Upon completion of the contract, transfer, at no cost, to Department all Public Records in possession of the contractor or keep and maintain Public Records required by Department to perform the service. If the contractor transfers all Public Records to Department upon completion of the contract, the contractor shall destroy any duplicate Public Records that are exempt or confidential and exempt from Public Records disclosure requirements. If the contractor keeps and maintains Public Records upon completion of the contract, the contractor shall meet all applicable requirements for retaining Public Records. All Public Records stored electronically must be provided to Department, upon request from Department's custodian of Public Records, in a format specified by Department as compatible with the information technology systems of Department. These formatting requirements are satisfied by using the data formats as authorized in the contract or Microsoft Word, Outlook, Adobe, or Excel, and any software formats the contractor is authorized to access.
- f. **IF THE CONTRACTOR HAS QUESTIONS REGARDING THE APPLICATION OF CHAPTER 119, F.S., TO THE CONTRACTOR'S DUTY TO PROVIDE PUBLIC RECORDS RELATING TO THE CONTRACT, CONTACT THE DEPARTMENT'S CUSTODIAN OF PUBLIC RECORDS AT:**

Telephone: (850) 245-2118
Email: public.services@floridadep.gov
Mailing Address: Department of Environmental Protection
ATTN: Office of Ombudsman and Public Services
Public Records Request
3900 Commonwealth Boulevard, MS 49
Tallahassee, Florida 32399

STATE OF FLORIDA
DEPARTMENT OF ENVIRONMENTAL PROTECTION
Special Audit Requirements

Attachment 5

The administration of resources awarded by the Department of Environmental Protection (*which may be referred to as the "Department", "DEP", "FDEP" or "Grantor", or other name in the agreement*) to the recipient (*which may be referred to as the "Recipient", "Grantee" or other name in the agreement*) may be subject to audits and/or monitoring by the Department of Environmental Protection, as described in this attachment.

MONITORING

In addition to reviews of audits conducted in accordance with OMB Circular A-133, as revised, 2 CFR Part 200, Subpart F, and Section 215.97, F.S., as revised (see "AUDITS" below), monitoring procedures may include, but not be limited to, on-site visits by Department staff, limited scope audits as defined by OMB Circular A-133, as revised, and 2 CFR Part 200, Subpart F, and/or other procedures. By entering into this Agreement, the recipient agrees to comply and cooperate with any monitoring procedures/processes deemed appropriate by the Department of Environmental Protection. In the event the Department of Environmental Protection determines that a limited scope audit of the recipient is appropriate, the recipient agrees to comply with any additional instructions provided by the Department to the recipient regarding such audit. The recipient further agrees to comply and cooperate with any inspections, reviews, investigations, or audits deemed necessary by the Chief Financial Officer or Auditor General.

AUDITS

PART I: FEDERALLY FUNDED

This part is applicable if the recipient is a State or local government or a non-profit organization as defined in OMB Circular A-133, as revised (for fiscal year start dates prior to December 26, 2014), or as defined in 2 CFR §200.330 (for fiscal year start dates after December 26, 2014).

1. In the event that the recipient expends \$500,000 (\$750,000 for fiscal year start dates after December 26, 2014) or more in Federal awards in its fiscal year, the recipient must have a single or program-specific audit conducted in accordance with the provisions of OMB Circular A-133, as revised, and 2 CFR Part 200, Subpart F. EXHIBIT 1 to this Attachment indicates Federal funds awarded through the Department of Environmental Protection by this Agreement. In determining the Federal awards expended in its fiscal year, the recipient shall consider all sources of Federal awards, including Federal resources received from the Department of Environmental Protection. The determination of amounts of Federal awards expended should be in accordance with the guidelines established by OMB Circular A-133, as revised, and 2 CFR Part 200, Subpart F. An audit of the recipient conducted by the Auditor General in accordance with the provisions of OMB Circular A-133, as revised, and 2 CFR Part 200, Subpart F, will meet the requirements of this part.
2. In connection with the audit requirements addressed in Part I, paragraph 1, the recipient shall fulfill the requirements relative to auditee responsibilities as provided in Subpart C of OMB Circular A-133, as revised, and 2 CFR Part 200, Subpart F.
3. If the recipient expends less than \$500,000 (or \$750,000, as applicable) in Federal awards in its fiscal year, an audit conducted in accordance with the provisions of OMB Circular A-133, as revised, and 2 CFR Part 200, Subpart F, is not required. In the event that the recipient expends less than \$500,000 (or \$750,000, as applicable) in Federal awards in its fiscal year and elects to have an audit conducted in accordance with the provisions of OMB Circular A-133, as revised, and 2 CFR Part 200, Subpart F the cost of the audit must be paid from non-Federal resources (i.e., the cost of such an audit must be paid from recipient resources obtained from other than Federal entities).

4. The recipient may access information regarding the Catalog of Federal Domestic Assistance (CFDA) via the internet at www.cfda.gov

PART II: STATE FUNDED

This part is applicable if the recipient is a nonstate entity as defined by Section 215.97(2)(n), Florida Statutes.

1. In the event that the recipient expends a total amount of state financial assistance equal to or in excess of \$750,000 in any fiscal year of such recipient, the recipient must have a State single or project-specific audit for such fiscal year in accordance with Section 215.97, Florida Statutes; applicable rules of the Department of Financial Services; and Chapters 10.550 (local governmental entities) or 10.650 (nonprofit and for-profit organizations), Rules of the Auditor General. EXHIBIT 1 to this Attachment indicates state financial assistance awarded through the Department of Environmental Protection by this Agreement. In determining the state financial assistance expended in its fiscal year, the recipient shall consider all sources of state financial assistance, including state financial assistance received from the Department of Environmental Protection, other state agencies, and other nonstate entities. State financial assistance does not include Federal direct or pass-through awards and resources received by a nonstate entity for Federal program matching requirements.
2. In connection with the audit requirements addressed in Part II, paragraph 1; the recipient shall ensure that the audit complies with the requirements of Section 215.97(7), Florida Statutes. This includes submission of a financial reporting package as defined by Section 215.97(2), Florida Statutes, and Chapters 10.550 (local governmental entities) or 10.650 (nonprofit and for-profit organizations), Rules of the Auditor General.
3. If the recipient expends less than \$750,000 in state financial assistance in its fiscal year, an audit conducted in accordance with the provisions of Section 215.97, Florida Statutes, is not required. In the event that the recipient expends less than \$750,000 in state financial assistance in its fiscal year, and elects to have an audit conducted in accordance with the provisions of Section 215.97, Florida Statutes, the cost of the audit must be paid from the non-state entity's resources (i.e., the cost of such an audit must be paid from the recipient's resources obtained from other than State entities).
4. For information regarding the Florida Catalog of State Financial Assistance (CSFA), a recipient should access the Florida Single Audit Act website located at <https://apps.fldfs.com/fsaa> for assistance. In addition to the above websites, the following websites may be accessed for information: Legislature's Website at <http://www.leg.state.fl.us/Welcome/index.cfm>, State of Florida's website at <http://www.myflorida.com/>, Department of Financial Services' Website at <http://www.fldfs.com/> and the Auditor General's Website at <http://www.myflorida.com/audgen/>.

PART III: OTHER AUDIT REQUIREMENTS

(NOTE: This part would be used to specify any additional audit requirements imposed by the State awarding entity that are solely a matter of that State awarding entity's policy (i.e., the audit is not required by Federal or State laws and is not in conflict with other Federal or State audit requirements). Pursuant to Section 215.97(8), Florida Statutes, State agencies may conduct or arrange for audits of State financial assistance that are in addition to audits conducted in accordance with Section 215.97, Florida Statutes. In such an event, the State awarding agency must arrange for funding the full cost of such additional audits.)

PART IV: REPORT SUBMISSION

1. Copies of reporting packages for audits conducted in accordance with OMB Circular A-133, as revised, and 2 CFR Part 200, Subpart F and required by PART I of this Attachment shall be submitted, when required by Section .320 (d), OMB Circular A-133, as revised, and 2 CFR Part 200, Subpart F, by or on behalf of the recipient directly to each of the following:

- A. The Department of Environmental Protection at one of the following addresses:

By Mail:

Audit Director
Florida Department of Environmental Protection
Office of the Inspector General, MS 40
3900 Commonwealth Boulevard
Tallahassee, Florida 32399-3000

Electronically:

FDEPSingleAudit@dep.state.fl.us

- B. The Federal Audit Clearinghouse designated in OMB Circular A-133, as revised, and 2 CFR §200.501(a) (the number of copies required by Sections .320 (d)(1) and (2), OMB Circular A-133, as revised, and 2 CFR §200.501(a) should be submitted to the Federal Audit Clearinghouse), at the following address:

Federal Audit Clearinghouse
Bureau of the Census
1201 East 10th Street
Jeffersonville, IN 47132

Submissions of the Single Audit reporting package for fiscal periods ending on or after January 1, 2008, must be submitted using the Federal Clearinghouse's Internet Data Entry System which can be found at <http://harvester.census.gov/facweb/>

- C. Other Federal agencies and pass-through entities in accordance with Sections .320 (e) and (f), OMB Circular A-133, as revised, and 2 CFR §200.512.

2. Pursuant to Section .320(f), OMB Circular A-133, as revised, and 2 CFR Part 200, Subpart F, the recipient shall submit a copy of the reporting package described in Section .320(c), OMB Circular A-133, as revised, and 2 CFR Part 200, Subpart F, and any management letters issued by the auditor, to the Department of Environmental Protection at one the following addresses:

By Mail:

Audit Director
Florida Department of Environmental Protection
Office of the Inspector General, MS 40
3900 Commonwealth Boulevard
Tallahassee, Florida 32399-3000

Electronically:

FDEPSingleAudit@dep.state.fl.us

3. Copies of financial reporting packages required by PART II of this Attachment shall be submitted by or on behalf of the recipient directly to each of the following:

- A. The Department of Environmental Protection at one of the following addresses:

By Mail:

Audit Director
Florida Department of Environmental Protection
Office of the Inspector General, MS 40
3900 Commonwealth Boulevard
Tallahassee, Florida 32399-3000

Electronically:
FDEPSingleAudit@dep.state.fl.us

B. The Auditor General's Office at the following address:

State of Florida Auditor General
Room 401, Claude Pepper Building
111 West Madison Street
Tallahassee, Florida 32399-1450

4. Copies of reports or management letters required by PART III of this Attachment shall be submitted by or on behalf of the recipient directly to the Department of Environmental Protection at one of the following addresses:

By Mail:

Audit Director
Florida Department of Environmental Protection
Office of the Inspector General, MS 40
3900 Commonwealth Boulevard
Tallahassee, Florida 32399-3000

Electronically:
FDEPSingleAudit@dep.state.fl.us

5. Any reports, management letters, or other information required to be submitted to the Department of Environmental Protection pursuant to this Agreement shall be submitted timely in accordance with OMB Circular A-133, as revised, and 2 CFR Part 200, Subpart F, Florida Statutes, or Chapters 10.550 (local governmental entities) or 10.650 (nonprofit and for-profit organizations), Rules of the Auditor General, as applicable.
6. Recipients, when submitting financial reporting packages to the Department of Environmental Protection for audits done in accordance with OMB Circular A-133, as revised and 2 CFR Part 200, Subpart F, or Chapters 10.550 (local governmental entities) or 10.650 (nonprofit and for-profit organizations), Rules of the Auditor General, should indicate the date that the reporting package was delivered to the recipient in correspondence accompanying the reporting package.

PART V: RECORD RETENTION

The recipient shall retain sufficient records demonstrating its compliance with the terms of this Agreement for a period of five (5) years from the date the audit report is issued, and shall allow the Department of Environmental Protection, or its designee, Chief Financial Officer, or Auditor General access to such records upon request. The recipient shall ensure that audit working papers are made available to the Department of Environmental Protection, or its designee, Chief Financial Officer, or Auditor General upon request for a period of three (3) years from the date the audit report is issued, unless extended in writing by the Department of Environmental Protection.

EXHIBIT – 1

FUNDS AWARDED TO THE RECIPIENT PURSUANT TO THIS AGREEMENT CONSIST OF THE FOLLOWING:

Federal Resources Awarded to the Recipient Pursuant to this Agreement Consist of the Following:					
Federal Program Number	Federal Agency	CFDA Number	CFDA Title	Funding Amount	State Appropriation Category
Original Agreement	U.S. Department of Interior, National Park Service	15.916	Outdoor Recreation, Acquisition, Development and Planning – Land and Water Conservation Fund Grants	\$148,500.00	14001

State Resources Awarded to the Recipient Pursuant to this Agreement Consist of the Following Matching Resources for Federal Programs:					
Federal Program Number	Federal Agency	CFDA	CFDA Title	Funding Amount	State Appropriation Category

State Resources Awarded to the Recipient Pursuant to this Agreement Consist of the Following Resources Subject to Section 215.97, F.S.:						
State Program Number	Funding Source	State Fiscal Year	CSFA Number	CSFA Title or Funding Source Description	Funding Amount	State Appropriation Category

Total Award				\$148,500.00	
--------------------	--	--	--	---------------------	--

For each program identified above, the recipient shall comply with the program requirements described in the Catalog of Federal Domestic Assistance (CFDA) [www.cfda.gov] and/or the Florida Catalog of State Financial Assistance (CSFA) [<https://apps.fldfs.com/fsaa/searchCatalog.aspx>]. The services/purposes for which the funds are to be used are included in the Agreement's Grant Work Plan. Any match required by the Recipient is clearly indicated in the Agreement.

STATE OF FLORIDA
DEPARTMENT OF ENVIRONMENTAL PROTECTION
PROGRAM SPECIFIC REQUIREMENTS

LAND AND WATER CONSERVATION FUND PROGRAM

ATTACHMENT 6

1. Project Submittal Forms.

Grantees can find the Administrative Forms, Reimbursement Forms, and Guidelines referenced in this Agreement at <https://floridadep.gov/lands/land-and-recreation-grants/content/land-and-water-conservation-fund-program>, or by contacting the Department's Grant Manager.

2. Notice to Commence.

Prior to starting the Project, the Grantee will provide to the Department all documentation listed on the Commencement Documentation Checklist, DRP-122. Once the commencement documentation is approved, the Department will issue a written "Notice to Commence" to the Grantee. **The Grantee MAY NOT proceed until the Department issues a "Notice to Commence."** The Grantee must start work on the Project **within 180 days** after the Department issues a "Notice to Commence" unless this deadline is extended by the Department for good cause. Until the Department issues the "Notice to Commence," the Department is not obligated to reimburse Grantee for fees, costs, or general expenses of any kind.

3. Site Plans.

Project site facilities must be attractive for public use and compatible with the environment. Plans and specifications for Project site improvements and facilities must be in accordance with current engineering and architectural standards. Grantees should emphasize the health and safety of users, accessibility to the general public, and the protection of the recreational and natural values of the area. A Grantee may alter a conceptual site plan only after written approval by the Department and National Park Service (NPS). All utility lines installed within the Project site must be placed underground.

The Grantee shall have final site plans (site, engineering, and architectural) prepared for the Project and sealed by a registered architect or engineer licensed in accordance with the laws of the State of Florida (collectively the "Project Plans"). The Grantee must deliver a complete original, signed, and sealed set of the Project Plans to the Department as a condition of and prior to beginning the Project.

4. The following supplements paragraph 2.d., Attachment 1, Standard Terms and Conditions:

The Department may, and in certain circumstances the NPS must, approve any changes to this Agreement. The Grantee may submit a request for an amendment to the Department's Grant Manager, who will determine whether the request requires NPS approval. This Agreement may be amended to provide for additional services if additional funding is made available by USDO, NPS, and the Florida Legislature.

5. The following paragraphs is added to paragraph 2, Attachment 1, Standard Terms and Conditions:

- f. The costs must meet all requirements and financial reporting of the LWCF Program and rules and regulations applicable to expenditures of federal and state funds. These rules and regulations are hereby adopted and incorporated by reference.
- g. This Agreement is not transferable.

6. The following replaces paragraph 8.d, Attachment 1, Standard Terms and Conditions:

d. Reimbursement for Costs.

Project costs will be reimbursed as provided in paragraph 62D-5.073(2)(a), F.A.C., the LWCF Manual, and in the Project Agreement. Project costs must be incurred between the effective date of this Agreement and the Project Completion Date. The Grantee will be paid on a cost reimbursement basis for all eligible Project costs upon the completion, submittal, and approval of each deliverable identified in the Grant Work Plan. Reimbursement must be requested on Exhibit C, Payment Request Summary Form. To be eligible for reimbursement, cost(s) must meet all LWCF requirements, financial reporting requirements, and rules and regulations applicable to expenditures of state funds, including, but not limited to, the Reference Guide for State

Expenditures, which can be accessed at the following web address: www.myfloridacfo.com/aadir/reference-guide/. If the total cost of the Project exceeds the grant amount and the required match, the Grantee must pay the excess cost. If the total cost of the Project exceeds the grant amount and the required match (if applicable), Grantee must pay the excess cost.

7. The following paragraph is added to paragraph 8, Attachment 1, Standard Terms and Conditions:
 - k. Cost Limits. Pursuant to paragraph 62D-5.073(2)(b), F.A.C., project planning expenses, such as application preparation, surveys (boundary and topographic), title searches, project signs, architectural and engineering fees, permitting fees, project inspection fees, and other similar fees are eligible Project costs provided that they do not exceed fifteen percent (15%) of the total Project cost.
8. The following replaces paragraph 8.h, Attachment 1, Standard Terms and Conditions:
 - h. Annual Appropriation Contingency. The State of Florida's performance and obligation to pay under this Agreement is contingent upon an annual appropriation by the Florida Legislature and the availability of funding and grants from the USDOJ and NPS. This Agreement is not a commitment of future appropriations. Authorization for continuation and completion of work and any associated payments may be rescinded, with proper notice, at the discretion of the Department if USDOJ, NPS, and/or the Florida Legislature reduces or eliminates appropriations. It is further understood that Grant Awards may be revised by the Department due to the availability of LWCF Program Funds.
9. The following replaces paragraph 10, Attachment 1, Standard Terms and Conditions:

Status Reports.

 - a. The Grantee must utilize Project Status Report Form, DRP-109, available online and incorporated herein by reference, to describe the work performed during the reporting period, problems encountered, problem resolutions, and to schedule updates and proposed work for the next reporting period. The Project Status Reports must be submitted to the Department's Grant Manager no later than January 5, May 5, and September 5. The Department's Grant Manager has thirty (30) calendar days to review the required reports and deliverables submitted by the Grantee.
 - b. Additionally, the Grantee shall comply with the reporting and inventory requirements set forth in the Statewide Comprehensive Outdoor Recreation Plan (SCORP), available online: <https://floridadep.gov/parks/florida-scorp-outdoor-recreation-florida> and hereby incorporated by reference, by updating the Florida Outdoor Recreation Inventory (FORI) system (<https://floridadep.gov/parks/florida-outdoor-recreation-inventory>).

10. Site Dedication.

The interest in land developed or acquired by the Grantee with LWCF Program Funds shall be subject to the site dedication requirements set forth in Chapter 62D-5, F.A.C. and of the LWCF Act, specifically Section 6(f)(3), as codified in 36 CFR § 59.3. Pursuant to the LWCF Act and general requirements of the LWCF Program, land owned by the Grantee that is developed or acquired with LWCF Program Funds shall be dedicated in perpetuity as an outdoor recreation site for the use and benefit of the public. Land that is leased from the federal government or another public agency by Grantee must include safeguards to ensure the perpetual use requirement contained in the LWCF Act. Safeguards include such things as joint sponsorship of the Project or an agreement between the Parties that the lessor will assume compliance responsibility for the Project site in the event of default by the lessee (Grantee) or termination or expiration of the lease. Execution of this Agreement by the Department constitutes an acceptance of a Project site(s) dedication on behalf of the public of the State of Florida. These dedications must be recorded in the county's public property records by the Grantee in accordance with subsection 62D-5.074(1), F.A.C.

11. Management of Project Sites.

- a. Site Inspections. Department staff will periodically inspect LWCF Projects to ensure compliance with subsections 62D-5.074(1)-(3), F.A.C., and section 675.9 of the LWCF manual. Grantees must ensure by site inspections that the property acquired or developed through the LWCF is being operated and maintained for outdoor recreation purposes.
- b. Management. All projects must be open at reasonable times and be managed in a safe and attractive manner appropriate for public use. Facilities must be kept in reasonable repair for a minimum of 25 years from the date set forth on the project completion certificate to prevent undue deterioration.
- c. Non-Compliance. Before a project is closed, the Department and the NPS have the right to terminate a project agreement and demand return of the program funds for non-compliance by a grantee. Failure by a grantee to

comply with the Agreement will result in the Department declaring the grantee ineligible for further participation in LWCF until the Grantee comes into compliance as determined by the Department under this rule and the LWCF Manual.

- d. **Survival.** This provision shall survive termination, cancellation, or expiration of this Agreement.

12. Procurement Requirements for Grantee.

The Grantee must secure all goods and services for the Project according to its adopted procurement procedures.

13. Project Completion Certification.

Project completion means the Project is open and available for use by the public. To certify completion, the Grantee will submit to the Department the Project Completion Certification, DRP-126, available online and incorporated herein by reference. The Project must be designated complete prior to the Department releasing final reimbursement.

14. Signage.

Grantee must erect a permanent information sign on the Project site that credits funding, or a portion thereof, to the Florida Department of Environmental Protection and the Land and Water Conservation Fund Program. Use of the LWCF Logo on the permanent Project signs is required. Grantee is encouraged to position signage acknowledging LWCF assistance at entrances to outdoor recreation sites, at other appropriate on-site locations, and in folders and park literature. The acknowledgement of LWCF assistance will be checked during compliance inspections. The sign must be installed on the Project site and approved by the Department before the final Project reimbursement request is processed. The required LWCF Logo, LWCF Terms of Use, and sample sign are available online: <https://floridadep.gov/lands/land-and-recreation-grants/content/land-and-water-conservation-fund-program>. This provision shall survive termination, cancellation, or expiration of this Agreement.

15. Termination and Ineligibility.

In addition to the remedies provided elsewhere in this Agreement, if the Grantee fails to comply with the terms stated in this Agreement or with any provisions in Rule Chapter 62D-5, F.A.C., the Department will terminate this Agreement and demand return of the LWCF program funds (including interest). Furthermore, the Department will declare the Grantee ineligible for further participation in LWCF until the Grantee is in compliance pursuant to subsection 62D-5.074(4), F.A.C. Further, the Grantee agrees to ensure that all necessary permits are obtained prior to implementing any Grant Work Plan activity that may fall under applicable federal, state, or local laws. This provision shall survive termination, cancellation, or expiration of this Agreement.

16. Conversion.

This Project site acquired and/or developed with LWCF assistance must be retained and used for public outdoor recreation. This Project site so acquired and/or developed may not be wholly or partly converted to other than public outdoor recreation uses without the written approval of the NPS pursuant to the conversion provisions of Section 6(f)(3) of the LWCF Act, 36 CFR Part 59, the LWCF Manual, and all other applicable regulations. All conversion provisions and guidelines apply to each area or facility for which LWCF assistance is obtained, regardless of the extent of participation of the Project in the assisted area or facility and consistent with the contractual agreement between USDOJ, NPS, and the State of Florida.

Should Grantee convert all or part of the Project site to other than public outdoor recreational uses, the Grantee is required to replace the area, facilities, resource, or Project site at its own expense with an acceptable project of comparable or greater value, scope, and quality pursuant to LWCF mandates. All conversions require amendments to the original Project agreement (36 CFR § 59.3(c)). Therefore, amendment requests should be submitted concurrently with conversion requests. Project boundary maps must be submitted with the amendment request to identify the changes to the original area caused by the proposed conversion and to establish a new Project area pursuant to the substitution. Once conversion has been approved, replacement property should be immediately acquired. When it is not possible for replacement property to be acquired immediately, an express commitment to satisfy Section 6(f)(3) substitution requirements with a specified period, normally not to exceed one (1) year following conversion approval, is required. This commitment will be in the form of an amendment to the original Agreement. This provision shall survive termination, cancellation, or expiration of this Agreement.

ATTACHMENT 8
Contract Provisions for DOI-Funded Agreements

The Department, as a Non-Federal Entity as defined by 2 CFR §200.69, shall comply with the following provisions, where applicable. For purposes of this Grant Agreement between the Department and the Grantee, the term "Recipient" shall mean "Grantee."

Further, the Department, as a pass-through entity, also requires the Grantee to pass on these requirements to all lower tier subrecipients, and to comply with the provisions of the award, including applicable provisions of the OMB Uniform Guidance (2 CFR Part 200), and all associated terms and conditions. Therefore, Grantees must include these requirements in all related subcontracts and/or sub-awards. Grantees can include these requirements by incorporating this Attachment in the related subcontract and/or sub-awards, however for all such subcontracts and sub-awards, the Grantee shall assume the role of the Non-Federal Entity and the subrecipients shall assume the role of the Recipient.

2 CFR PART 200 APPENDIX 2 REQUIREMENTS

1. Administrative, Contractual, and Legal Remedies

The following provision is required if the Agreement is for more than \$150,000. In addition to any of the remedies described in the elsewhere in the Agreement, if the Recipient materially fails to comply with the terms and conditions of this Contract, including any Federal or State statutes, rules or regulations, applicable to this Contract, the Non-Federal Entity may take one or more of the following actions.

- i. Temporarily withhold payments pending correction of the deficiency by the Recipient.
- ii. Disallow (that is, deny both use of funds and any applicable matching credit for) all or part of the cost of the activity or action not in compliance.
- iii. Wholly or partly suspend or terminate this Contract.
- iv. Take other remedies that may be legally available.

The remedies identified above, do not preclude the Recipient from being subject to debarment and suspension under Presidential Executive Orders 12549 and 12689. The Non-Federal entity shall have the right to demand a refund, either in whole or part, of the funds provided to the Recipient for noncompliance with the terms of this Agreement.

2. Termination for Cause and Convenience

Termination for Cause and Convenience are addressed elsewhere in the Agreement.

3. Equal Opportunity Clause

The following provision applies if the agreement meets the definition of "federally assisted construction contract" as defined by 41 CFR Part 60-1.3:

During the performance of this Agreement, the Recipient agrees as follows:

- i. The Recipient will not discriminate against any employee or applicant for employment because of race, color, religion, sex, sexual orientation, gender identity, or national origin. The Recipient will take affirmative action to ensure that applicants are employed, and that employees are treated during employment without regard to their race, color, religion, sex, sexual orientation, gender identity, or national origin. Such action shall include, but not be limited to the following:
 - a. Employment, upgrading, demotion, or transfer; recruitment or recruitment advertising; layoff or termination; rates of pay or other forms of compensation; and selection for training, including apprenticeship. The Recipient agrees to post in conspicuous places, available to employees and applicants for employment, notices to be provided setting forth the provisions of this nondiscrimination clause.
- ii. The Recipient will, in all solicitations or advertisements for employees placed by or on behalf of the Recipient, state that all qualified applicants will receive consideration for employment without regard to race, color, religion, sex, sexual orientation, gender identity, or national origin.
- iii. The Recipient will not discharge or in any other manner discriminate against any employee or applicant for employment because such employee or applicant has inquired

about, discussed, or disclosed the compensation of the employee or applicant or another employee or applicant. This provision shall not apply to instances in which an employee who has access to the compensation information of other employees or applicants as a part of such employee's essential job functions discloses the compensation of such other employees or applicants to individuals who do not otherwise have access to such information, unless such disclosure is in response to a formal complaint or charge, in furtherance of an investigation, proceeding, hearing, or action, including an investigation conducted by the employer, or is consistent with the Recipient's legal duty to furnish information.

- iv. The Recipient will send to each labor union or representative of workers with which he has a collective bargaining agreement or other Agreement or understanding, a notice to be provided advising the said labor union or workers' representatives of the Recipient's commitments under this section, and shall post copies of the notice in conspicuous places available to employees and applicants for employment.
- v. The Recipient will comply with all provisions of Executive Order 11246 of September 24, 1965, and of the rules, regulations, and relevant orders of the Secretary of Labor.
- vi. The Recipient will furnish all information and reports required by Executive Order 11246 of September 24, 1965, and by rules, regulations, and orders of the Secretary of Labor, or pursuant thereto, and will permit access to his books, records, and accounts by the administering agency and the Secretary of Labor for purposes of investigation to ascertain compliance with such rules, regulations, and orders.
- vii. In the event of the Recipient's noncompliance with the nondiscrimination clauses of this Agreement or with any of the said rules, regulations, or orders, this Agreement may be canceled, terminated, or suspended in whole or in part and the Recipient may be declared ineligible for further Government contracts or federally assisted construction contracts in accordance with procedures authorized in Executive Order 11246 of September 24, 1965, and such other sanctions may be imposed and remedies invoked as provided in Executive Order 11246 of September 24, 1965, or by rule, regulation, or order of the Secretary of Labor, or as otherwise provided by law.
- viii. The Recipient will include the portion of the sentence immediately preceding paragraph (1) and the provisions of paragraphs (1) through (8) in every subcontract or purchase order unless exempted by rules, regulations, or orders of the Secretary of Labor issued pursuant to section 204 of Executive Order 11246 of September 24, 1965, so that such provisions will be binding upon each subcontractor or vendor. The Recipient will take such action with respect to any subcontractor purchase order as the administering agency may direct as a means of enforcing such provisions, including sanctions for noncompliance.

4. Davis Bacon Act

If the Agreement is a prime construction contract in excess of \$2,000 awarded by the Recipient, and if required by the Federal Legislation, the Recipient must comply with the Davis-Bacon Act (40 U.S.C. 3141-3144, and 3146-3148) as supplemented by Department of Labor regulations (29 CFR Part 5, "Labor Standards Provisions Applicable to Contracts Covering Federally Financed and Assisted Construction"). In accordance with the statute, contractors must pay wages to laborers and mechanics at a rate not less than the prevailing wages specified in a wage determination made by the Secretary of Labor. In addition, contractors must pay wages not less than once a week. The Recipient must comply with the Copeland "Anti-Kickback" Act (40 U.S.C. 3145), as supplemented by Department of Labor regulations (29 CFR Part 3, "Contractors and Subcontractors on Public Building or Public Work Financed in Whole or in Part by Loans or Grants from the United States"). The Act provides that each Recipient or subrecipient must be prohibited from inducing, by any means, any person employed in the construction, completion, or repair of public work, to give up any part of the compensation to which he or she is otherwise entitled.

5. Contract Work Hours and Safety Standards Act

Where applicable, if the Agreement is in excess of \$100,000 and involves the employment of mechanics or laborers, the Recipient must comply with 40 U.S.C. 3702 and 3704, as supplemented by Department of Labor regulations (29 CFR Part 5). Under 40 U.S.C. 3702 of the Act, each Recipient must be required to compute the wages of every mechanic and laborer on the basis of a standard work week of 40 hours. Work in excess of the standard work week is permissible provided that the worker is compensated at a rate of not

less than one and a half times the basic rate of pay for all hours worked in excess of 40 hours in the work week. The requirements of 40 U.S.C. 3704 are applicable to construction work and provide that no laborer or mechanic must be required to work in surroundings or under working conditions which are unsanitary, hazardous or dangerous. These requirements do not apply to the purchases of supplies or materials or articles ordinarily available on the open market, or contracts for transportation or transmission of intelligence.

6. Rights to Inventions Made Under Agreement

If the Federal award meets the definition of "funding agreement" under 37 CFR §401.2 (a) and the Non-Federal Entity or subrecipient wishes to enter into a contract with a small business firm or nonprofit organization regarding the substitution of parties, assignment or performance of experimental, developmental, or research work under that "funding agreement," the Non-Federal Entity or subrecipient must comply with the requirements of 37 CFR Part 401, "Rights to Inventions Made by Nonprofit Organizations and Small Business Firms Under Government Grants, Contracts and Cooperative Agreements," and any implementing regulations issued by the awarding agency.

7. Clean Air Act (42 U.S.C. 7401-7671q.) and the Federal Water Pollution Control Act (33 U.S.C. 1251-1387)

If the Agreement is in excess of \$150,000, the Recipient shall comply with all applicable standards, orders or regulations issued pursuant to the Clean Air Act (42 U.S.C. 7401-7671q) and the Federal Water Pollution Control Act as amended (33 U.S.C. 1251-1387). Violations must be reported to the Federal Awarding Agency and the Regional Office of the Environmental Protection Agency (EPA).

8. Debarment and Suspension (Executive Orders 12549 and 12689)

The Recipient certifies that it is not listed on the governmentwide exclusions in the System for Award Management (SAM), in accordance with the OMB guidelines at 2 CFR 180 that implement Executive Orders 12549 (3 CFR part 1986 Comp., p. 189) and 12689 (3 CFR part 1989 Comp., p. 235), "Debarment and Suspension."

9. Byrd Anti-Lobbying Amendment (31 U.S.C. 1352)

The Recipient certifies that it will not and has not used Federal appropriated funds to pay any person or organization for influencing or attempting to influence an officer or employee of any agency, a member of Congress, officer or employee of Congress, or an employee of a member of Congress in connection with obtaining any Federal contract, grant or any other award covered by 31 U.S.C. 1352. If applicable, the Recipient shall disclose any lobbying with non-Federal funds that takes place in connection with obtaining any Federal award, using form SF-LLL, available at:

https://apply07.grants.gov/apply/forms/sample/SFLLL_1_2_P-V1.2.pdf.

10. Procurement of Recovered Materials

The Recipient must comply with Section 6002 of the Solid Waste Disposal Act, as amended by the Resource Conservation and Recovery Act as described in 2 CFR part 200.322.

ADMINISTRATIVE

11. General Federal Regulations

Recipients shall comply with the regulations listed in 2 CFR 200, 48 CFR 31, and 40 U.S.C. 1101 *et sequence*.

12. Rights to Patents and Inventions Made Under a Contract or Agreement

Rights to inventions made under this assistance agreement are subject to federal patent and licensing regulations, which are codified at Title 37 CFR Part 401 and Title 35 U.S.C. 200 through 212.

13. Compliance with the Trafficking Victims Protection Act of 2000 (2 CFR Part 175)

Recipients, their employees, subrecipients under this award, and subrecipients' employees may not:

- i. Engage in severe forms of trafficking in persons during the period of time that the award is in effect;
- ii. Procure a commercial sex act during the period of time that the award is in effect; or
- iii. Use forced labor in the performance of the award or subawards under the award.

14. Section 102(a) of the Flood Disaster Protection Act of 1973 (P.L. 93-234)

Recipients must comply with flood insurance purchase requirements of Section 102(a) of the Flood Disaster Protection Act of 1973 (P.L. 93-234), if applicable. This act requires recipients in a special flood hazard area to participate in the program and to purchase flood insurance if the total cost of insurable construction and acquisition is \$10,000 or more.

15. Water Resources Reform and Development Act (WRRDA) P.L. 113-121

Recipients must comply with the Water Resources Reform and Development Act (WRRDA) P.L. 113-121, if applicable. This act provides for improvements to the rivers and harbors of the United States, to provide for the conservation and development of water and related resources.

16. Whistleblower Protection

Recipients shall comply with U.S.C. §4712, Enhancement of Recipient and Subrecipient Employee Whistleblower Protection. This requirement applies to all awards issued after July 1, 2013 and effective December 14, 2016 has been permanently extended (Public Law (P.L.) 114-261).

(a) This award, related subawards, and related contracts over the simplified acquisition threshold and all employees working on this award, related subawards, and related contracts over the simplified acquisition threshold are subject to the whistleblower rights and remedies in the pilot program on award recipient employee whistleblower protections established at 41 U.S.C. 4712 by section 828 of the National Defense Authorization Act for Fiscal Year 2013 (P.L. 112-239).

(b) Recipients, their subrecipients, and their contractors awarded contracts over the simplified acquisition threshold related to this award, shall inform their employees in writing, in the predominant language of the workforce, of the employee whistleblower rights and protections under 41 U.S.C. 4712.

(c) The Recipient shall insert this clause, including this paragraph (c), in all subawards and in contracts over the simplified acquisition threshold related to this award; best efforts should be made to include this clause, including this paragraph (c) in any subawards and contracts awarded prior to the effective date of this provision.

17. Notification of Termination (2 CFR § 200.340)

In accordance with 2 CFR § 200.340, in the event that the Agreement is terminated prior to the end of the period of performance due to the Recipient's or subcontractor's material failure to comply with Federal statutes, regulations or the terms and conditions of this Agreement or the Federal award, the termination shall be reported to the Office of Management and Budget (OMB)-designated integrity and performance system, accessible through System for Award Management (SAM) currently the Federal Awardee Performance and Integrity Information System (FAPIIS). The Non-Federal Entity will notify the Recipient of the termination and the Federal requirement to report the termination in FAPIIS. See 2 CFR § 200.340 for the requirements of the notice and the Recipient's rights upon termination and following termination.

18. Additional Lobbying Requirements

(a) The Recipient certifies that no funds provided under this Agreement have been used or will be used to engage in the lobbying of the Federal Government or in litigation against the United States unless authorized under existing law.

(b) The Lobbying Disclosure Act of 1995, as amended (2 U.S.C. §1601 *et seq.*), prohibits any organization described in Section 501(c)(4) of the Internal Revenue Code, from receiving federal funds through an award, grant (and/or subgrant) or loan unless such organization warrants that it does not, and will not engage in lobbying activities prohibited by the Act as a special condition of such an award, grant (and/or subgrant), or loan. This restriction does not apply to loans made pursuant to approved revolving loan programs or to contracts awarded using proper procurement procedures.

(c) Pursuant to 2 CFR §200.450 and 2 CFR §200.454(e), the Recipient is hereby prohibited from using funds provided by this Agreement for membership dues to any entity or organization engaged in lobbying activities.

COMPLIANCE WITH ASSURANCES

19. Assurances

Recipients shall comply with any and all applicable assurances made by the Department or the Recipient to the Federal Government during the Grant application process.

FEDERAL REPORTING REQUIREMENTS

Grant Recipients awarded a new Federal grant greater than or equal to \$30,000 awarded on or after October 1, 2015, are subject to the FFATA the Federal Funding Accountability and Transparency Act ("FFATA") of 2006. The FFATA legislation requires that information on federal awards (federal financial assistance and expenditures) be made available to the public via a single, searchable website, which is www.USASpending.gov. The Grantee agrees to provide the information necessary, within one (1) month of execution, for the Department to comply with this requirement.

DEPARTMENT OF INTERIOR-SPECIFIC

20. Department of Interior (DOI) General Terms and Conditions

Recipients shall comply with DOI General Terms and Conditions available at https://www.doi.gov/pam/programs/financial_assistance/TermsandConditions, and incorporated by reference.

21. DOI Regulations

Recipients shall comply with the following regulations: 2 CFR 1400-1402, 43 CFR 9, 43 CFR 17, 43 CFR 18, 43 CFR 41, and 43 CFR 44.

22. Drug-Free Workplace

Recipients must make an ongoing, good faith effort to maintain a drug-free workplace pursuant to the specific requirements set forth in Title 2 CFR Part 1401. Additionally, in accordance with these regulations, the recipients must identify all known workplaces under its federal awards, and keep this information on file during the performance of the award.

23. Titles II and III of the Uniform Relocation Assistance and Real Property Acquisition Policies Act

As applicable, Recipient shall comply with the requirements of the Uniform Relocation Assistance and Real Property Acquisition Policies Act of 1970 (P.L. 91-646) to provide for fair and equitable treatment of persons displaced or whose property is acquired as a result of Federal or federally assisted programs. These requirements apply to all interests in real property acquired for project purposes regardless of Federal participation in purchases.

24. Deposit of Publications Produced under Grants

Pursuant to Departmental Manual 505 DM4 (DOI) and Service Manual FW1 (USFWS), any grant or cooperative agreement that will produce a publication (other than those listed as exceptions) must provide two copies of each publication to the Department of Interior's Natural Resources Library. For a list of exceptions, transmittal requirements, and delivery information see Departmental Manual 505 DM 4, Deposit of Publications Produced under Grants at: <http://elips.doi.gov/ELIPS/DocView.aspx?id=1671>.

UNITED STATES FISH & WILDLIFE SERVICE-SPECIFIC

25. USFWS Financial Assistance Award Terms and Conditions

Recipients shall comply with the USFWS Financial Assistance Award Terms and Conditions applicable to the specific Federal Award funding source, available at <https://www.fws.gov/grants/atc.html>, and incorporated by reference.

NATIONAL PARKS SERVICE LAND AND WATER CONSERVATION FUND STATE ASSISTANCE PROGRAM-SPECIFIC

26. LWCF Federal Financial Assistance Manual

As applicable, Recipients shall comply with the LWCF Federal Financial Assistance Manual Effective October 1, 2008, or later, available at <https://www.nps.gov/subjects/lwcf/lwcf-manual.htm>, and incorporated by reference.

27. Historic Preservation.

As applicable, Recipients shall comply with Section 106 of the National Historic Preservation Act of 1966, as amended (16 U.S.C. 470), E.O. 11593 (identification and protection of historic properties), and the Archaeological and Historic Preservation Act of 1974 (16 U.S.C. 469a-1 *et seq.*).

REMAINDER OF PAGE INTENTIONALLY LEFT BLANK



Florida Department of Environmental Protection

EXHIBIT A
Land and Water Conservation Fund Program
Florida Recreation Development Assistance Program
Recreational Trails Program
Project Status Report

Required Signatures: Adobe Signature

Project Name: _____ Project Number: _____

Project Sponsor: _____

Identify primary and support recreation areas and facilities to be constructed. (50% of total costs must be in primary facilities).

PROVIDE PHOTOS OF WORK IN PROGRESS

PRIMARY FACILITIES/ELEMENTS:

Project Elements	Work Accomplished	% Completed

SUPPORT FACILITIES/ELEMENTS:

Project Elements	Work Accomplished	% Completed

PROBLEMS ENCOUNTERED:

Period Covered (Check Appropriate Period):

January through April:

May through August:

September through December:

Due May 5th

Due September 5th

Due January 5th

LIAISON: _____
Signature

_____ Date



Florida Department of Environmental Protection

EXHIBIT C
PAYMENT REQUEST SUMMARY FORM
Land and Water Conservation Fund Program Florida
Recreation Development Assistance Program
Recreational Trails Program

Required Signatures: Adobe Signature

Date:

Grantee

Project Name and Number

Billing Period:

Billing #:

DEP Division:

DEP Program:

Table with 3 columns: Description, Project Costs This Billing, Cumulative Project Costs. Rows include Contractual Services, Grantee Labor, Employee Benefits, Direct Purchases, Grantee Stock, Equipment, Land Value, Indirect Costs, and TOTAL PROJECT COSTS.

CERTIFICATION: I hereby certify that the above expenses were incurred for the work being accomplished in the attached progress reports.

Project Administrator

Date

CERTIFICATION: I hereby certify that the documentation has been maintained as required to support the project expenses as reported above and is available for audit upon request.

Project Financial Officer

Date

DEP USE ONLY

STATE FUNDING PARTICIPATION: _____ %

Total project costs to date	\$
State Obligation to date	\$
State retainage (_____ %)	\$
State obligation remaining	\$
State funds previously disbursed	\$
State funds due this billing	\$

Reviewed and approved by:

DEP Project Administrator

Date

Division Director or Designee

Date

APPENDIX 4

Subsurface Soil Exploration and Geotechnical Engineering Evaluation

Headquarters
11345 U.S. Highway 1
Sebastian, FL. 32958
Orlando
723 Progress Way
Sanford, FL. 32771



Mailing
P.O. Box 78-1377
Sebastian, FL. 32978
Phone: 772-589-0712
C.A. # 5693
KSMengineering.net

September 16, 2020

Beth Powell
Indian River County Parks & Conservation Resources
5500 77th Street
Vero Beach, FL 32967

**Re: Hallstrom House (FTC No. 01-055-FF1)
Old Dixie Highway SW, North of 1st Street SE
Vero Beach, Florida
KSM Project #: 204419-b**

Dear Ms. Powell:

As requested, KSM Engineering & Testing has performed a subsurface investigation at the referenced site. Presentation of the data gathered during the investigation, together with our geotechnical related opinions, are included in this report.

At the time of drilling, the site was flat with moderate surface vegetation and few oak trees.

Project Description:

A pavilion and a restroom building, 900 sf and 315 sf, are planned to be constructed on the site as part of a new nature trail network project. Loads from the structures will be transferred to the ground by conventional shallow footings. We anticipate maximum wall loads for the structures will be less than 1,500 pounds per linear foot along the wall foundation and less than 10 kips for any individual column load. Roadways and stabilized walking paths will be constructed as part of this project.

Some site fill may be required to reach the desired grades.

Headquarters
11345 U.S. Highway 1
Sebastian, FL. 32958
Orlando
723 Progress Way
Sanford, FL. 32771



Mailing
P.O. Box 78-1377
Sebastian, FL. 32978
Phone: 772-589-0712
C.A. # 5693
KSMengineering.net

Hallstrom House
Vero Beach, Florida

-2-

September 16, 2020

Site Investigation:

The site investigation program consisted of performing two (2) Standard Penetration Test borings (SPT), and two (2) hand-auger borings on the site. The borings were terminated at depths of 10 to 14 feet below existing grade. The locations of the borings are shown on the attached location plan.

The SPT borings were completed in accordance with procedures described in ASTM D 1586. A standard 1.5 inch I.D., 2 inch O.D. split-spoon sampler is driven into the soil by successive blows of a 140 pound hammer freely falling 30 inches. The number of blows required to drive the sampler 1 foot, after seating 6 in., is designated the penetration Resistance, or "N" value. At regular intervals the sampler is extracted from the ground and opened to allow visual examination and classification of the retained soil sample. Also, the groundwater table was allowed to stabilize and the depth of the groundwater elevation recorded from existing grade.

The records of the soils encountered, the penetration resistances and groundwater level are shown on the attached logs.

Engineering Evaluation and Conclusions:

Based on the information obtained from this site investigation we are pleased to offer the following evaluation:

The boring logs indicate the subsurface soils from the surface to a depth of approximately 6 feet consist of very loose fine-grained sand with typical surface roots. Below the very loose surface soil, medium-dense layers of fine-grained sand were found. Please refer to the soil boring logs for specific information relative to the soil description.

The very loose layers of sand would cause settlement to the planned structures. This settlement, in our opinion, would be too excessive and beyond the general accepted safe limits for the structure. Therefore, our recommendations are concerned with removing the very soft soils and replacing them with compacted sand.

The following sections provide recommendations for the site preparation and foundation design.

Headquarters
11345 U.S. Highway 1
Sebastian, FL. 32958
Orlando
723 Progress Way
Sanford, FL. 32771



Mailing
P.O. Box 78-1377
Sebastian, FL. 32978
Phone: 772-589-0712
C.A. # 5693
KSMengineering.net

Hallstrom House
Vero Beach, Florida

-3-

September 16, 2020

Site Preparation:

Excavate the very loose sand from within the proposed building limits and five feet beyond the perimeter of the building. Based on the boring logs, this would require removing approximately 4 feet of soils in order to get compaction to 6 feet below grade. Excavated fine sand may be stockpiled and re-used provided that it is not mixed with organic or other unsuitable material. All over-excavation of unsuitable soils, replacement, and compaction of suitable clean fine sand backfill material should take place in the "dry". After the very loose soils have been removed and the bottom layer has been properly compacted to a depth of 2 feet below grade, the site may be filled to the desired grades.

Structural fill shall consist of clean granular sand containing less than 10% material passing the U.S. Standard No. 200 mesh sieve. Fill should be placed in layers of 12 inches in thickness. Compact each lift to at least 95 percent of its modified Proctor value (ASTM D 1557).

After excavating for the footings, the disturbed footing subgrade should be recompact to 95 percent (minimum) of its modified dry Proctor value. This can be best achieved by making several passes with a relatively light-weight walk-behind vibratory sled or roller. Tests in the excavated footings should be conducted prior to placement of any steel or concrete and conducted at every column footing and once for every 100 linear feet of footing trench.

In-place density of the compacted soil can be verified using a nuclear density gauge. The subgrade and each lift of fill should be tested for compaction at a frequency no less than one test per 2,500 sf of building area, per lift and one test per 10,000 sf of roadway area, per lift with a minimum of 4 tests in each area prepared. Due to the material, moisture may need to be introduced to achieve compaction, consult with onsite soils technician if difficulty achieving compaction is evident.

Excavation:

Excavations should be sloped as necessary to prevent slope failure and to allow backfilling. As a minimum, temporary excavations below 4-foot depth should be sloped in accordance with OSHA regulations. Where lateral confinement will not permit slopes to be laid back, the excavation should be shored in accordance with OSHA requirements. During excavation, excavated material should not be stockpiled at the top of the slope within a horizontal distance equal to the excavation depth. Provisions for maintaining workman safety within excavations is the sole responsibility of the contractor.

Headquarters
11345 U.S. Highway 1
Sebastian, FL. 32958
Orlando
723 Progress Way
Sanford, FL. 32771



Mailing
P.O. Box 78-1377
Sebastian, FL. 32978
Phone: 772-589-0712
C.A. # 5693
KSMengineering.net

Hallstrom House
Vero Beach, Florida

September 16, 2020

Foundation:

Providing our recommendations for site preparation are followed, the proposed structures may be supported on conventional concrete, steel reinforced footings designed for an allowable soil bearing pressure of 2,000 pounds per square foot, or less.

With the foundation properly designed and the site properly prepared, we anticipate total settlements less than 1/2 of an inch and differential settlements of less than 1/4 of an inch. The majority of the settlement should occur during construction.

Floor Slabs:

A conventional slab-on-grade can be used in the "at grade" portion of the structures. We recommend the disturbed subgrade below the floor slab be re-compacted to 95 percent of the modified Proctor maximum dry density (ASTM D 1557) prior to placement of the concrete. An estimated modulus of subgrade reaction of 150 pounds per cubic inch (pci) can be used for design of the slab-on-grade. We recommend that control joints be incorporated in the slab at frequent intervals to control shrinkage cracks.

A moisture barrier is recommended beneath the floor slab to prevent moisture migration from the underlying soil resulting in dampness of the slab.

Drives and Parking Areas: (Standard Duty Only)

We performed two (2) hand-augers in the proposed roadway to evaluate the soils in relation to the proposed pavement. We did not find any "muck" or other unsuitable material in the test borings. Penetrometer readings recorded during the investigation indicates the existing soil density is loose on the surface to firm. The relationship of the static cone penetrometer readings which are shown on the logs to the relative density is listed below:

Relative Density	Static Penetrometer Reading
Very Loose or Soft	<15
Loose	15 – 40
Medium Dense	40 – 70
Dense	70+

Headquarters
11345 U.S. Highway 1
Sebastian, FL. 32958
Orlando
723 Progress Way
Sanford, FL. 32771



Mailing
P.O. Box 78-1377
Sebastian, FL. 32978
Phone: 772-589-0712
C.A. # 5693
KSMengineering.net

Hallstrom House
Vero Beach, Florida

-5-

September 16, 2020

Although a comprehensive pavement evaluation was not within the scope of this study the site may be prepared to support a flexible pavement or rigid concrete pavement. The pavement should be designed for the anticipated loads and frequencies. The minimum pavement design for standard duty asphalt should include the following:

Clear the roadway area of any surface debris, including vegetation, roots and organic matter. Stumps shall be removed entirely. The cleared areas should be graded level and proof rolled. Any soft yielding areas shall be excavated and replaced with clean compacted fill. Sufficient passes should be made during compaction operations to produce a density no less than 95 percent of its modified dry Proctor value (AASHTO T180) to a depth of two feet. This is especially important on this site due to the amount of loose surface soils.

Additional fill shall consist of clean granular sand containing less than 10% material passing the U.S. Standard No. 200 mesh sieve and placed in loose layers of 12 inches and compacted to the above densities.

Eight inches of suitable clayed soil having a Limerock Bearing Ratio (LBR) of 40 should be used for the stabilized subgrade and compacted to 98 percent of its modified dry Proctor value (AASHTO T180).

The base course shall be six inches of cemented coquina rock (LBR of 100) or limerock and compacted to 98 percent of its modified dry Proctor value (AASHTO T180). A minimum of 16 inches separation should be maintained between the bottom of the base and the high seasonal groundwater table.

The asphalt wearing surface should consist of 1 ½" of type S-3 in accordance with the Florida Department of Transportation Standard Specification for Road and Bridge Construction.

Standard duty pavement areas are considered car and pickup truck loading conditions and a few medium trucks such as delivery and garbage truck loading conditions.

Headquarters
11345 U.S. Highway 1
Sebastian, FL. 32958
Orlando
723 Progress Way
Sanford, FL. 32771



Mailing
P.O. Box 78-1377
Sebastian, FL. 32978
Phone: 772-589-0712
C.A. # 5693
KSMengineering.net

Hallstrom House
Vero Beach, Florida

-6-

September 16, 2020

Closure:

This report has been prepared in accordance with generally accepted soil and foundation engineering practice based on the results of the test borings and assumed loading conditions. This report does not reflect any variations which may occur between the borings. If variations appear evident during the course of construction, it would be necessary to re-evaluate the recommendations of this project.

We are pleased to be of assistance to you on this phase of your project. When we may be of further service to you or should you have any questions, please feel free to contact the office.

Respectfully,

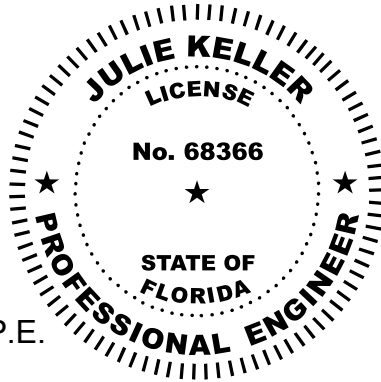

Julie E. Keller, P.E.
President
P.E. # 68366

JEK/cv

Email to: aarons@mbveng.com



KSM Engineering & Testing
 P.O. Box 78-1377
 Sebastian, FL 32978
 Tel: (772)-589-0712
 Fax: (772)-589-6469

BORING NUMBER B-1

CLIENT Indian River County Parks & Conservation Resources **PROJECT NAME** Hallstrom House (FTC No. 01-055-FF1)
PROJECT NUMBER 204419-p&b **PROJECT LOCATION** Vero Beach, Florida
DATE STARTED 9/15/20 **COMPLETED** 9/15/20 **GROUND ELEVATION** _____ **HOLE SIZE** inches
DRILLING CONTRACTOR _____ **GROUND WATER LEVELS:**
DRILLING METHOD Split Spoon Sample **AT TIME OF DRILLING** 8.42 ft
LOGGED BY DP/JY **CHECKED BY** JEK **AT END OF DRILLING** ---
NOTES See Attached Location Plan **AFTER DRILLING** ---

DEPTH (ft)	GRAPHIC LOG	MATERIAL DESCRIPTION	SAMPLE TYPE NUMBER	RECOVERY % (RQD)	BLOW COUNTS (N VALUE)	POCKET PEN. (tsf)	DRY UNIT WT. (pcf)	▲ SPT N VALUE ▲		
								20	40	60
0		Brown Sand with Traces of Roots								
		Yellowish Brown Sand	X SS		1-1-2 (3)					
			X SS		1-2-2 (4)					
5			X SS		2-1-2 (3)					
			X SS		2-2-2 (4)					
		Grayish Brown Sand	X SS		2-2-3 (5)					
10										

Bottom of borehole at 10.0 feet.

GEOTECH BH PLOTS - GINT STD US LAB.GDT - 9/18/20 08:13 - K:\KSM FILES\20 DOCS (KSM-SERVER)\204419-P&B.GPJ



KSM Engineering & Testing
 P.O. Box 78-1377
 Sebastian, FL 32978
 Tel: (772)-589-0712
 Fax: (772)-589-6469

BORING NUMBER B-2

CLIENT Indian River County Parks & Conservation Resources
PROJECT NUMBER 204419-p&b
DATE STARTED 9/15/20 **COMPLETED** 9/15/20
DRILLING CONTRACTOR _____
DRILLING METHOD Split Spoon Sample
LOGGED BY DP/JY **CHECKED BY** JEK
NOTES See Attached Location Plan

PROJECT NAME Hallstrom House (FTC No. 01-055-FF1)
PROJECT LOCATION Vero Beach, Florida
GROUND ELEVATION _____ **HOLE SIZE** inches
GROUND WATER LEVELS:
 ▽ **AT TIME OF DRILLING** 8.75 ft
AT END OF DRILLING ---
AFTER DRILLING ---

DEPTH (ft)	GRAPHIC LOG	MATERIAL DESCRIPTION	SAMPLE TYPE NUMBER	RECOVERY % (RQD)	BLOW COUNTS (N VALUE)	POCKET PEN. (tsf)	DRY UNIT WT. (pcf)	▲ SPT N VALUE ▲		
								20	40	60
0		Brown Sand with Traces of Roots								
		Yellowish Brown Sand	SS		2-2-2 (4)					
			SS		2-1-2 (3)					
5			SS		2-1-2 (3)					
			SS		1-2-2 (4)					
10		Grayish Brown Sand	SS		1-2-2 (4)					
		Light Gray Sand	SS		4-5-6 (11)					
			SS		5-5-5 (10)					

Bottom of borehole at 14.0 feet.

GEOTECH BH PLOTS - GINT STD US LAB.GDT - 9/18/20 08:13 - K:\KSM FILES\20 DOCS (KSM-SERVER)\204419-P&B.GPJ



KSM Engineering & Testing
 P.O. Box 78-1377
 Sebastian, FL 32978
 Tel: (772)-589-0712
 Fax: (772)-589-6469

BORING NUMBER HA-1

CLIENT Indian River County Parks & Conservation Resources **PROJECT NAME** Hallstrom House (FTC No. 01-055-FF1)
PROJECT NUMBER 204419-p&b **PROJECT LOCATION** Vero Beach, Florida
DATE STARTED 9/15/20 **COMPLETED** 9/15/20 **GROUND ELEVATION** _____ **HOLE SIZE** inches
DRILLING CONTRACTOR _____ **GROUND WATER LEVELS:**
DRILLING METHOD _____ **AT TIME OF DRILLING** 6.00 ft
LOGGED BY DP/JY **CHECKED BY** JEK **AT END OF DRILLING** ---
NOTES See Attached Location Plan **AFTER DRILLING** ---

DEPTH (ft)	GRAPHIC LOG	MATERIAL DESCRIPTION	SAMPLE TYPE NUMBER	RECOVERY % (RQD)	BLOW COUNTS (N VALUE)	POCKET PEN. (tsf)	DRY UNIT WT. (pcf)	▲ SPT N VALUE ▲	
								PL	MC LL
0								20	40 60 80
		Brown Sand with Traces of Roots				20			20 40 60 80
		Yellowish Brown Sand				24			20 40 60 80
						22			20 40 60 80
						25			20 40 60 80
5						27			20 40 60 80
						26			20 40 60 80

Bottom of borehole at 6.0 feet.



KSM Engineering & Testing
 P.O. Box 78-1377
 Sebastian, FL 32978
 Tel: (772)-589-0712
 Fax: (772)-589-6469

BORING NUMBER HA-2

CLIENT Indian River County Parks & Conservation Resources **PROJECT NAME** Hallstrom House (FTC No. 01-055-FF1)
PROJECT NUMBER 204419-p&b **PROJECT LOCATION** Vero Beach, Florida
DATE STARTED 9/15/20 **COMPLETED** 9/15/20 **GROUND ELEVATION** _____ **HOLE SIZE** inches
DRILLING CONTRACTOR _____ **GROUND WATER LEVELS:**
DRILLING METHOD _____ **AT TIME OF DRILLING** 6.00 ft
LOGGED BY DP/JY **CHECKED BY** JEK **AT END OF DRILLING** ---
NOTES See Attached Location Plan **AFTER DRILLING** ---

DEPTH (ft)	GRAPHIC LOG	MATERIAL DESCRIPTION	SAMPLE TYPE NUMBER	RECOVERY % (RQD)	BLOW COUNTS (N VALUE)	POCKET PEN. (tsf)	DRY UNIT WT. (pcf)	▲ SPT N VALUE ▲	
								PL	MC LL
0								20	40 60 80
		Gray Sand with Traces of Roots				24			
		Light Gray Sand				27			
		Yellowish Brown Sand				26			
5						28			
						28			
						27			

Bottom of borehole at 6.0 feet.

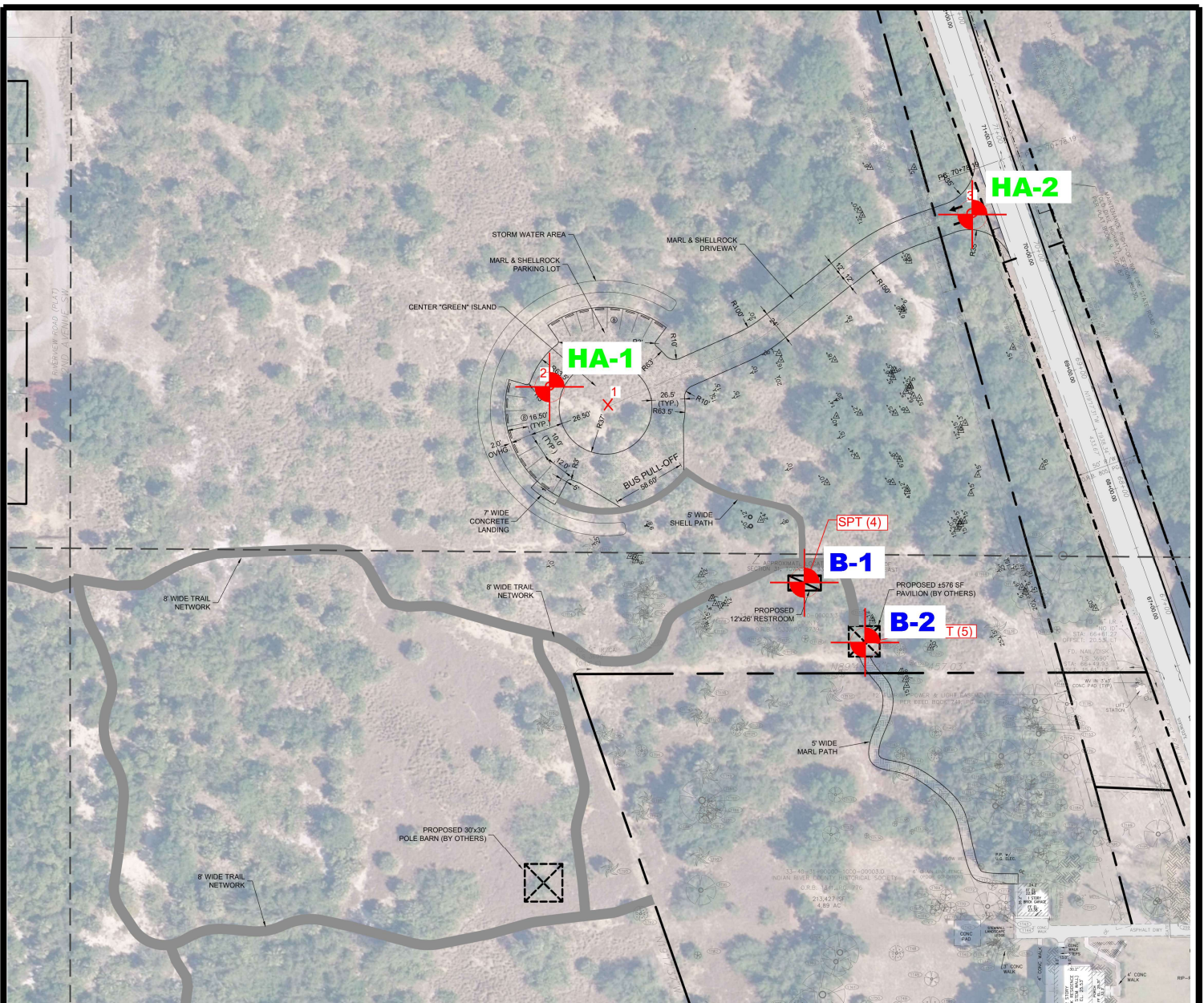

 **LOCATION OF TESTS**

PROJECT: Hallstrom House (FTC No. 01-055-FF1), Old Dixie Highway SW, N. of 1st Street SE, Vero Beach, Florida

SHEET 1 OF 1
 PERMIT #:
 PROJECT #: 204419-b



DRAWN BY: C.V.
 DESIGNED BY: J.K.
 DATE: 20200918
 SCALE: NONE

Headquarters
11345 U.S. Highway 1
Sebastian, FL. 32958
Orlando
723 Progress Way
Sanford, FL. 32771



Mailing
P.O. Box 78-1377
Sebastian, FL. 32978
Phone: 772-589-0712
C.A. # 5693
KSMengineering.net

September 16, 2020

Beth Powell
Indian River County Parks & Conservation Resources
5500 77th Street
Vero Beach, FL 32967

**Re: Hallstrom House (FTC No. 01-055-FF1)
Old Dixie Highway SW, North of 1st Street SE
Vero Beach, Florida
KSM Project #: 204419-p**

Dear Ms. Powell:

Enclosed are the permeability test results and soil profile for the referenced project.

A Hydraulic Conductivity Test was performed in the field by the 'Usual Open-Hole Test' method.

The horizontal and vertical permeability flow rates were determined by excavating a test pit adjacent to the soil profiles and obtaining undisturbed shelly tube samples. We then performed a permeability test on the field samples in our laboratory.

All these tests were performed to evaluate the drainage characteristics of the soils for this particular test location.

The following table indicates the usual Open Hole Hydraulic Conductivity test results:

TEST LOCATION (See Location Plan)	HYDRAULIC CONDUCTIVITY (CFS/Sq. Ft. – Ft. Head)
P-1	9.7×10^{-4}

Headquarters
 11345 U.S. Highway 1
 Sebastian, FL. 32958
 Orlando
 723 Progress Way
 Sanford, FL. 32771



Mailing
 P.O. Box 78-1377
 Sebastian, FL. 32978
 Phone: 772-589-0712
 C.A. # 5693
 KSMengineering.net

Hallstrom House
 Vero Beach, Florida

-2-

September 16, 2020

The following table indicates the horizontal and vertical flow rates for the test location. These tests were performed in accordance with ASTM D-2434 and are performed in a saturated condition.

TEST LOCATION (See Location Plan)	HORIZONTAL FLOW RATE	VERTICAL FLOW RATE
P-1	27.2 Ft/Day @ (0"-8") Depth	25.0 Ft/Day @ (0"-8") Depth
P-1	115.5 Ft/Day @ (8"-132") Depth	105.9 Ft/Day @ (8"-132") Depth

The following table indicates the measured water table along with our estimated normal wet season water table and normal dry season water table for the test location:

TEST LOCATION (See Location Plan)	MEASURED WATER TABLE	ESTIMATED WET SEASON WATER TABLE	ESTIMATED DRY SEASON WATER TABLE
P-1, PB-1	148" Below Grade	136" Below Grade	172" Below Grade

This estimate is based upon our interpretation of existing site conditions and a review of the USDA Soil Survey for Indian River County, Florida. The majority of the site soils are mapped as (4) Immokalee fine sand, (8) Paola sand, 0 to 5 percent slopes, (11) St. Lucie sand, 0 to 8 percent slopes, (12) Archbold sand, 0 to 5 percent slopes, (21) Pomello sand, 0 to 5 percent slopes, and (33) Astatula sand, 0 to 5 percent slopes, according to the Soil Survey Map of Indian River County, Florida.

If you have any questions, please feel free to contact the office.

Respectfully,

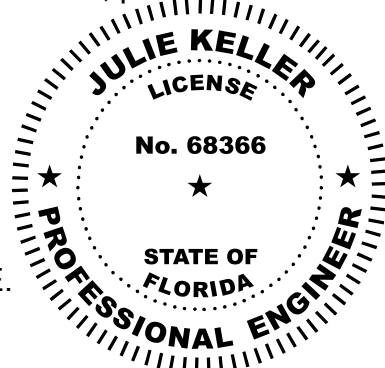

Julie E. Keller, P.E.
 President
 P.E. # 68366

JEK/cv
 Email to: aarons@mbveng.com



KSM Engineering & Testing
 P.O. Box 78-1377
 Sebastian, FL 32978
 Tel: (772)-589-0712
 Fax: (772)-589-6469

BORING NUMBER PB-1

CLIENT Indian River County Parks & Conservation Resources
PROJECT NUMBER 204419-p&b
DATE STARTED 9/15/20 **COMPLETED** 9/15/20
DRILLING CONTRACTOR _____
DRILLING METHOD Split Spoon Sample
LOGGED BY DP/JY **CHECKED BY** JEK
NOTES See Attached Location Plan

PROJECT NAME Hallstrom House (FTC No. 01-055-FF1)
PROJECT LOCATION Vero Beach, Florida
GROUND ELEVATION _____ **HOLE SIZE** inches
GROUND WATER LEVELS:
 ▽ **AT TIME OF DRILLING** 12.33 ft
AT END OF DRILLING ---
AFTER DRILLING ---

DEPTH (ft)	GRAPHIC LOG	MATERIAL DESCRIPTION	SAMPLE TYPE NUMBER	RECOVERY % (RQD)	BLOW COUNTS (N VALUE)	POCKET PEN. (tsf)	DRY UNIT WT. (pcf)	▲ SPT N VALUE ▲		
								20	40	60
0		Brown Sand with Traces of Roots								
		Yellowish Brown Sand	SS		1-2-2 (4)					
			SS		2-2-1 (3)					
5			SS		2-1-2 (3)					
			SS		2-1-2 (3)					
10		Grayish Brown Sand	SS		2-2-2 (4)					
		Light Gray Sand	SS		2-3-4 (7)					
					4-6-7 (13)					

Bottom of borehole at 14.0 feet.

GEOTECH BH PLOTS - GINT STD US LAB.GDT - 9/18/20 08:41 - K:\KSM FILES\20 DOCS (KSM-SERVER)\204419-P&B.GPJ

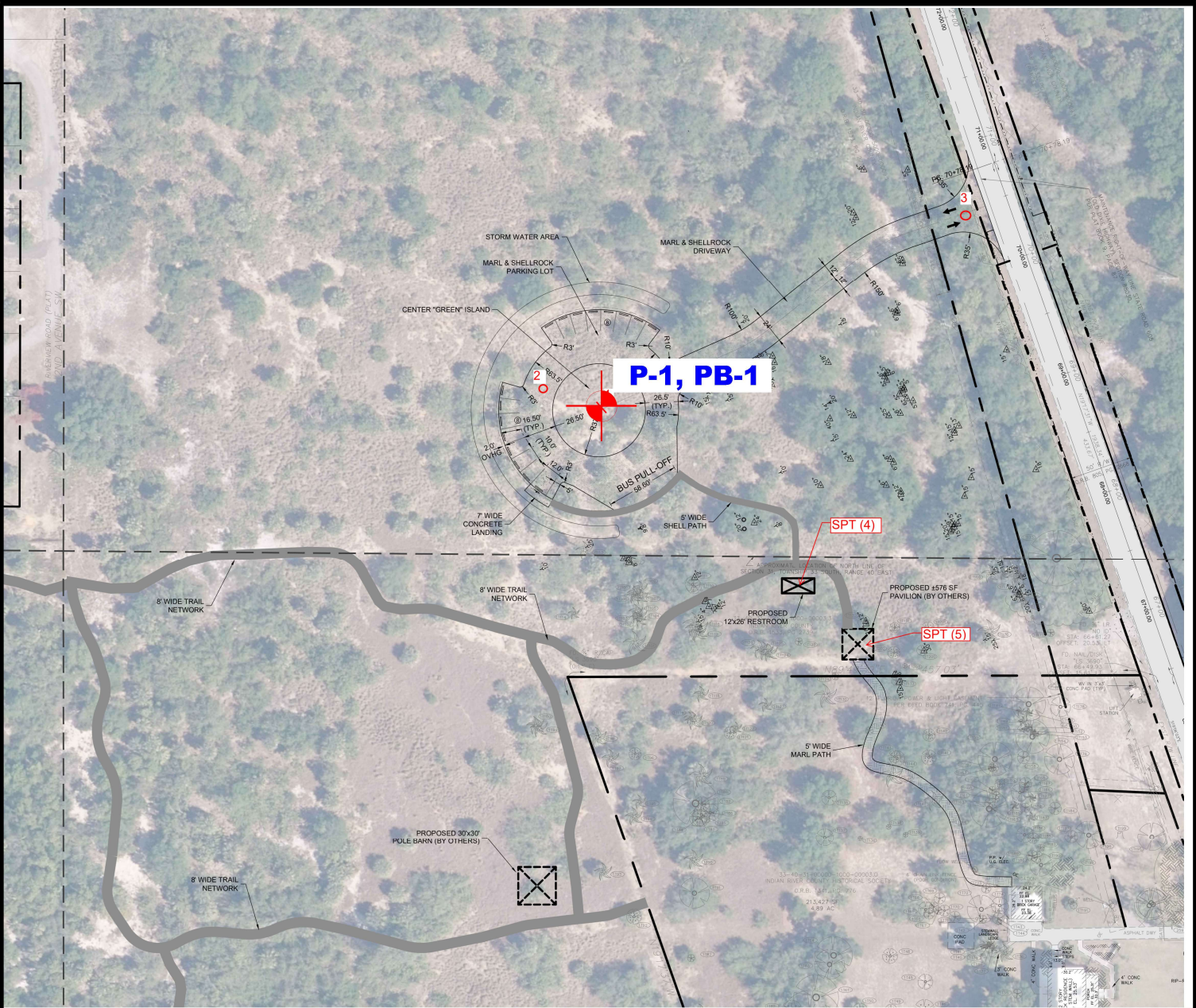

LOCATION OF TESTS

PROJECT: Hallstrom House (FTC No. 01-055-FF1), Old Dixie Highway SW, N. of 1st Street SE, Vero Beach, Florida

SHEET 1 OF 2
 PERMIT #:
 PROJECT #: 204419-p



DRAWN BY: C.V.
DESIGNED BY: J.K.
DATE: 20200918
SCALE: NONE



USDA SOILS SURVEY

4-Immokalee Fine Sand

8-Paola Sand, 0 to 5 Percent Slopes

11-St. Lucie Sand, 0 to 8 Percent Slopes

12-Archbold Sand, 0 to 5 Percent Slopes

21-Pomello Sand, 0 to 5 Percent Slopes

33-Astatula Sand, 0 to 5 Percent Slopes

PROJECT: Hallstrom House (FTC No. 01-055-FF1), Old Dixie Highway SW, N. of 1st Street SE, Vero Beach, Florida

SHEET 2 OF 2
 PERMIT #:
 PROJECT #: 204419-soils



DRAWN BY: C.V.
 DESIGNED BY: J.K.
 DATE: 20200918
 SCALE: NONE

APPENDIX 5

IRC BUILDING DEPARTMENT FEE SCHEDULE

Indian River County Building Division Permit Fee Schedule

#	Permit Type	Application Fee	Permit Fee	Comments
1	New Buildings, Alterations, Mobile and Modular Homes	\$200.00	0.394% of ICC Building Valuation over \$50,765	Base permit fee includes subcontractor work (electrical, plumbing, mechanical, insulation, alarm, and irrigation) if subcontractor work is shown on the permit documents, if the value of the subcontractor work is included as part of the aggregate construction value and if subcontractor affidavits are submitted with the application. Commercial Site work and all Accessory Structures are excluded.
2	Additions, Alterations, Misc. Commercial			

Residential / Commercial Trade Permits				
#		Permit Fee	Comments	
3	Aboveground Swimming Pool	\$75.00	Additional permit fee of 0.394% of contract / work order valuation over \$19,039; permit fee due at time of application. Fee Includes one inspection. Trade permits requiring plan review subject to a \$55 plan review fee.	
4	Burglar Alarm	\$75.00		
5	Electric	\$75.00		
6	Electrical	\$75.00		
7	Electrical Service Change	\$75.00		
8	Electrical Temporary Pole	\$75.00		
9	Fence	\$75.00		
10	Fuel Gas	\$75.00		
11	In-fill Screening	\$75.00		
12	Insulation	\$75.00		
13	Irrigation System	\$75.00		
14	Mechanical	\$75.00		
15	Plumbing	\$75.00		
16	Pool Barrier (excluding screened enclosure)	\$75.00		
17	Pre-fabricated detached accessory structure	\$75.00		
18	Residential Paving (Driveway, Patio Slab)	\$75.00		
19	Solar water or PV	\$75.00		
Residential Specialty Permits				
#	Permit Type	Permit Fee		Comments
20	Door / Window - Replacement / Hurricane Shutters	\$75.00	Fee includes up to 4 components or openings Additional permit fee of 0.394% of contract / work order valuation over \$19,039; permit fee due at time of application. Fee Includes one inspection. Trade permits requiring plan review subject to a \$55 plan review fee.	
21	Door / Window - Replacement / Hurricane Shutters	\$200.00	Greater than 4 components or openings Additional permit fee of 0.394% of contract / work order valuation over \$50,765; permit fee due at time of application.	
22	Garage door replacement - (1Door)	\$75.00	\$25 for each additional door in the same building / unit Additional permit fee of 0.394% of contract / work order valuation over \$19,039; permit fee due at time of application. Fee Includes one inspection. Trade permits requiring plan review subject to a \$55 plan review fee.	

Level-1 Specialty Permits					
#	Permit Type	Permit Application Fee	Comments		
23	Aluminum Structures	\$200.00	Additional permit fee of 0.394% of contract / work order valuation over \$50,765; permit fee due at time of application.		
24	Sign	\$200.00			
25	Demolition	\$200.00			
26	Deck, Dock or Seawall	\$200.00			
27	Door or window replacement- Commercial	\$200.00			
28	Garage doors replacement – Commercial	\$200.00			
29	House Moving	\$200.00			Separate Alteration permit required for foundation and improvements at relocation site.
30	Hurricane Shutters - Commercial	\$225.00			
31	Site-Built Accessory Structure	\$200.00			
32	Commercial Paving	\$200.00			
Level-2 Residential and Commercial Specialty Permits					
#	Permit Type	Application Fee	Permit Fee	Comments	
33	Miscellaneous Permits: e.g: Fixed Station Generator		\$225.00	Additional permit fee of 0.394% of contract / work order valuation over \$57,108; permit fee due at time of application.	
34	Re-roofing		\$225.00		
35	Residential Pool		\$225.00		
36	Commercial Pool	\$200.00	\$250.00		
INSPECTION RELATED FEES					
		FEE		Comments	
37	Re-inspection fee	\$45.00		[1] failure to comply with code/plan requirements. [2] unproductive inspector trip (unable to access the work or not ready for inspection). [3] Advisory Inspection requested by contractor or owner.	
38	After-Hour Inspections	\$50 / hour. Minimum 4-hour charge		Must be arranged 2 days in advance.	

	Plan Review	FEE		Comments
39	1st and 2nd Application / Plan Rejection / Modification	\$100 each		When content fails to meet sufficiency Requirement Check List (per state statute).
40	3rd and subsequent Application / Plan Rejection / Modification	Three (4) times the original plan review fee (1/3 permit fee)		When content fails to meet sufficiency Requirement Check List (per state statute).
41	Revision - small format	\$50.00		one 8.5 x 11 sheet
42	Revision - large format	\$100.00		plan sheets - large format - or more than one 8.5x11
43	Pre-Application Design Review	\$100.00		
Contractor Licensing				
		FEE		
44	Competency Card Application Fee	\$50.00		
45	Competency Card Renewal Fee	\$50.00		
Administrative Service Fees				
		FEE		Comments
46	Microfilm / Microfiche Document Requests Document Research	See Archive Request form		
47	Digital Document requests	See Archive Request form		
48	Paper documents from database or copier	0.25* / 0.50** per page fee		8.5x11*, 8.5x14*, 11x17**
49	Change of contractor	\$50.00		
50	Change of sub-contractor	\$20.00		
GENERAL INFORMATION				
	Valuation methodology	Valuation is based on the greater of contract value or latest ICC valuation table or as otherwise acceptable to the Building Official for specialty work not addressed by the ICC valuation table. The job valuation must include labor, overhead and profit. Valuation of total improvement (excluding land) shall be used.		
	Penalties (statutory).	Any person who commences any work requiring a permit before obtaining the permit shall be subject to a penalty of one hundred percent (100%) (Double) of the standard permit fee. The payment of such penalty shall not relieve any person(s) from complying with the requirement of the Building Code, the IRC Code of Ordinances, any applicable laws, or this resolution		
	Multiple Buildings	Multiple Buildings on one property: Work in common areas of buildings is individually permitted per building not per property.		
	Refunds	Permit and Permit Application fees are non-refundable.		

APPENDIX 6

INDIAN RIVER COUNTY TRAFFIC SPECIAL CONDITIONS FOR RIGHT OF WAY CONSTRUCTION



INDIAN RIVER COUNTY TRAFFIC ENGINEERING DIVISION SPECIAL CONDITIONS FOR RIGHT-OF-WAY CONSTRUCTION

SPECIAL CONDITIONS:

1. All work performed under this permit shall be in accordance with the Florida Department of Transportation Design Standards (<https://www.fdot.gov/design/standardplans/current/default.shtm>), Indices 102-600 and the Manual on Uniform Traffic Control Devices.
2. All special conditions listed are in addition to the attached Indian River County Traffic Engineering Regulations for Maintenance of Traffic.
3. It shall be the contractor's responsibility to contact Sunshine State One Call System (1-800-432-4770) at least 72 hours in advance of commencing construction work to coordinate traffic control and obtain locations of underground traffic signal conduit for the County's Computerized Traffic Signal Coordination System.
4. The contractor shall be responsible for using the applicable Traffic Control Plan for the type of work being performed. All job supervisors shall have a copy of the control plan on site at all times and shall be familiar with the correct set-up of the plan.
5. At least one lane of traffic shall be maintained at all times. One-lane traffic shall be controlled with at least two (2) flagmen. Flagmen shall use STOP/SLOW paddles at all times. Flags shall not be used for one-lane traffic control.
6. **After proper notification to Traffic Engineering**, consideration will be given to the contractor to close roadways to through traffic on a daily basis during daylight hours on narrow roadways where maintaining one-lane traffic would be difficult. The roadway shall be open to traffic at the end of each work day and on weekends. It shall be the contractor's responsibility to provide all necessary construction signs and traffic control devices to close the road and provide a detour route in accordance with Indian River County standards. Signing shall be installed that clearly indicates the time periods the road is closed to traffic.
7. There shall be no construction work after dark.
8. All open excavations shall be back filled before the close of each work day.
9. A compacted roadway shall be provided at the end of each work day. Disrupted roadways shall be clearly marked as a construction area.
10. Refer to the attached Traffic Engineering Regulations for construction work on Indian River County roadways for maintenance of traffic inspection policy and procedure
11. All construction equipment, materials, etc. shall be stored outside of the clear zone. Equipment and construction materials that are stored within the clear zone shall be clearly marked with Type II barricades with flashing yellow lights.
12. All projects and work within Indian River County right-of-way shall have an approved Traffic Control Plan (TCP). All work shall be executed under the established TCP and Indian River County approved procedures. The TCP shall provide the proposed detour route, traffic control devices, and other pertinent information for the proposed project and shall be submitted for review and approval by the Public Works Department.
The TCP shall be prepared by personnel with a minimum of an Intermediate Maintenance of Traffic current certification in the State of Florida. (Denote on the TCP, certification number and name of the certified personnel that prepared the MOT plan.)
For full road closures, a TCP is required to be submitted by the contractor a minimum of two (2) weeks prior to the proposed road closure.

All traffic control devices shall be in accordance with the Florida Department of Transportation (FDOT) Design Standards, Indices 102-600, FY 2019-2020, and the Manual on Uniform Traffic Control Devices, 2009 Edition.
13. For full road closures, Portable Changeable Message Signs are required to pre-advertise the roadway closure, a minimum of seven (7) days in advance of the road closure and during the duration of the road closure. The use of Portable Changeable Message Signs for lane closures on thoroughfare plan roadways will be required. Messages are to be approved by the Public Works Department and shown on the TCP.

TRAFFIC ENGINEERING REGULATIONS

Maintenance and Protection of Traffic:

It shall be the responsibility of the contractor to provide for the maintenance and protection of traffic in accordance with the applicable indices in the most current edition of the Florida Department of Transportation Roadway and Traffic Design Standards and the Federal Highway Administration Manual on Uniform Traffic Control Devices. The indices shall be considered the minimum standards and a

Special Conditions for Right of Way Construction

Page 2

more extensive work zone set-up or modifications may be required by the County Public Work Director or his designee for the protection of personnel in the work area as well as the traveling public.

It shall be the responsibility of the contractor to ensure that all subcontractors are in full compliance with all traffic control regulations. It shall be the responsibility of the contractor working on County roadways or within Right-of-Ways to establish maintenance of traffic prior to any work being performed. The contractor shall frequently monitor the work zone set-up to ensure that all signing is properly placed and that warning signs remain at the proper advance posting distance from the work area. Any signs that do not apply to the work zone shall be removed or covered. The contractor shall remove the work zone set-up at the conclusion of the work.

Traffic Engineering shall be notified a minimum of seventy-two (72) hours in advance of any lane closings and ten (10) days in advance of any road closures.

Lane closures are restricted to outside the normal peak hours of traffic, lane closures shall occur during the hours of 9:00 AM to 4:00 PM unless otherwise approved by the Public Works Director or his designee.

Traffic Engineering staff shall inspect the Maintenance of Traffic prior to construction commencement to ensure compliance with the approved Traffic Control Plan.

It is the policy of the Traffic Engineering Division to randomly monitor the contractor's compliance with all regulations while working on County roadways and within right-of-ways. Matters of public safety shall be attended to immediately upon notification by the County Public Work Director or his designee.

If the contractor is found to be negligent in maintaining proper work zone set-up in accordance with the County's Right-of-Way ordinance (Chapter 312), the County Public Work Director or his designee shall impose penalties in the amount of \$250.00 for working without the proper traffic control.

Construction at or Near Signalized Intersections:

The contractor shall have full responsibility for any work performed at or near any traffic signals in Indian River County. The contractor shall request that the County locate buried interconnect conduit and cable, loop sensors, and pull boxes prior to commencing construction. Any damage to the interconnect conduit, loop sensors, and pull boxes or any other traffic signal equipment shall be repaired at the contractor's expense. It shall be the responsibility of the contractor to notify Traffic Engineering Division a minimum of 72 hours prior to any work being performed near a signalized intersection or flashing beacon.

Once the proper notification and locate procedures are satisfied, the contractor working in or near signalized intersections or around traffic signal poles, signal cabinets, or flashing beacons shall be advised of the following regulations:

1. No excavation shall be performed within a 15-foot radius of any traffic signal pole. If excavation is necessary within a 15-foot radius, it will be the contractors responsibility to provide the following:
 - a. In a manner approved by the County Public Works Director or his designee, the contractor shall provide constant support of the traffic signal pole to prevent movement during excavation and backfill operations.
 - b. Compaction around the excavation site to a 98% density, bringing the backfill up in 1 foot lifts.
 - c. Density reports from a licensed testing company provided to the County Public Works Director.
 - d. Restore the traffic signal and all support equipment to original condition or better.
2. There shall be no pavement cuts made within 500 feet of a signal or flashing beacon without contacting Indian River County Traffic Engineering Division at (772-226-1547), 72 hours prior to construction.
3. Any traffic signal, loop sensors, conduit, interconnect cable, or any support equipment damaged by a contractor shall be repaired/replaced at the contractor's expense.
4. Any contractor that works at or in the vicinity of a signalized intersection shall have full responsibility for any liability incurred by causing damage to signal equipment that results in the failure of the traffic signal functions. If such a failure occurs, the contractor shall notify the police and the Traffic Engineering Division immediately at (772-226-1547).

APPENDIX 7

INDIAN RIVER COUNTY FERTILIZER ORDINANCE

ORDINANCE NO. 2013 - 012

AN ORDINANCE OF THE BOARD OF COUNTY COMMISSIONERS OF INDIAN RIVER COUNTY, FLORIDA, AMENDING THE CODE OF INDIAN RIVER COUNTY TO ESTABLISH A NEW CHAPTER 316, ENTITLED "FERTILIZER AND LANDSCAPE MANAGEMENT;" ADOPTING THE FLORIDA DEPARTMENT OF ENVIRONMENTAL PROTECTION'S MODEL ORDINANCE FOR FLORIDA-FRIENDLY USE OF FERTILIZER ON URBAN LANDSCAPES, WITH MODIFICATIONS; MAKING FINDINGS AND PROVIDING FOR SEVERABILITY, CODIFICATION; DIRECTING COUNTY ATTORNEY'S OFFICE TO POST SUMMARY ON COUNTY WEBSITE, AND AN EFFECTIVE DATE.

WHEREAS, as a result of impairment to Indian River County's surface waters caused by excessive nutrients, or, as a result of increasing levels of nitrogen in the surface and/or ground water within the aquifers or canals within the boundaries of Indian River County, the Board of County Commissioners has determined that the use of fertilizers on lands within Indian River County creates a risk of contributing to adverse effects on surface and/or ground water; and

WHEREAS, in order to address this risk, the Board of County Commissioners has determined that it is not only critical to adopt the Florida Department of Environmental Protection's Model Ordinance for Florida-Friendly Use of Fertilizer on Urban Landscapes, but that as part of Indian River County's science-based, and economically and technically feasible, comprehensive program to address nonpoint sources of nutrient pollution, additional and more stringent standards are necessary in order to adequately address urban fertilizer contributions to nonpoint source nutrient loading to the surface and/or ground water of Indian River County; and

WHEREAS, this ordinance regulates the proper use of fertilizers by any applicator; requires proper training of Commercial Fertilizer Applicators and Institutional Fertilizer Applicators; establishes training and licensing requirements; establishes a Prohibited Application Period; and specifies allowable fertilizer application rates and methods, fertilizer-free zones, low maintenance zones, and exemptions. The ordinance requires the use of Best Management Practices which provide specific management guidelines to minimize negative secondary and cumulative environmental effects associated with the misuse of fertilizers. These secondary and cumulative effects have been observed in and on Indian River County's natural and constructed stormwater conveyances, rivers, creeks, canals, lakes, estuaries and other water bodies. Collectively, these water bodies are an asset critical to the environmental, recreational, cultural and economic well-being of Indian River County residents and the health of the public. Overgrowth of algae and vegetation hinder the effectiveness of flood attenuation provided by natural and constructed stormwater conveyances. Regulation of nutrients, including both phosphorus and nitrogen contained in fertilizer, will help improve and maintain water and habitat quality,

ORDINANCE NO. 2013 - 012

NOW, THEREFORE, BE IT ORDAINED BY THE BOARD OF COUNTY COMMISSIONERS OF INDIAN RIVER COUNTY, FLORIDA, THAT:

Section 1. Enactment Authority.

Article VIII, §1 of the Florida Constitution and Chapter 125, Florida Statutes vest broad home rule powers in counties to enact ordinances, not inconsistent with general or special law, for the purpose of promoting the public health, safety and welfare of the residents of the county. The Board specifically determines that the enactment of this ordinance is consistent with general or special law, and is necessary and appropriate to promote the health, safety and welfare of the residents of Indian River County.

Section 2. Findings.

The Board finds that the above “Whereas” clauses are true and correct, and hereby incorporates such clauses as findings of the Board.

Section 3. Adoption of Chapter 316 of the Code of Indian River County (the “Code”).

Chapter 316 of the Code is hereby adopted, as follows (new language is indicated by underline):

Section 316.1. Title.

This chapter shall be known as the “Indian River County Fertilizer and Landscape Management Ordinance.”

Section 316.2. Definitions.

For the purposes of this chapter, the following terms shall have the following meanings:

“Administrator” shall mean the County Administrator, or an administrative official of the County designated by the County Administrator to administer and enforce the provisions of this chapter.

“Application” or “apply” shall mean the actual physical deposit of fertilizer to turf or landscape plants.

“Applicator” shall mean any Person who applies fertilizer on turf and/or landscape plants in Indian River County.

“Board” shall mean the Indian River County Board of County Commissioners.

“Best Management Practices” shall mean turf and landscape practices or combination of practices based on research, field-testing, and expert review, determined to be the most effective

ORDINANCE NO. 2013 - _____

and practicable on-location means, including economic and technological considerations, for improving water quality, conserving water supplies and protecting natural resources.

“Chapter 85-427” shall mean The Indian River County Environmental Control Act, Chapter 85-427, Special Acts, Laws of Florida.

“Code Enforcement Officer shall mean any designated employee or agent of Indian River County whose duty it is to enforce codes and ordinances enacted by Indian River County.

“Commercial Fertilizer Applicator,” except as provided in §482.1562(9), Florida Statutes, shall mean any person who applies fertilizer for payment or other consideration to property not owned by the person or firm applying the fertilizer or the employer of the applicator.

“Code” shall mean The Code of Indian River County.

“Environmental Control Officer” shall mean the Indian River County Environmental Control Officer appointed by the Board pursuant to Chapter 85-427, and Chapter 303 (Part I) of this Code, and his or her designees.

“Fertilize,” “fertilizing,” or “fertilization” shall mean the act of applying fertilizer to turf, specialized turf, or landscape plants.

“Fertilizer” shall mean any substance or mixture of substances that contains one or more recognized plant nutrients and promotes plant growth, or controls soil acidity or alkalinity, or provides other soil enrichment, or provides other corrective measures to the soil.

“Heavy rain” shall mean rainfall greater than two inches in a 24 hour period.

“Institutional Fertilizer Applicator” shall mean any person, other than a private, non-commercial applicator or a Commercial Fertilizer Applicator (unless such definitions also apply under the circumstances), that applies fertilizer for the purpose of maintaining turf and/or landscape plants. Institutional Fertilizer Applicators shall include, but shall not be limited to, owners, managers or employees of public lands, schools, parks, religious institutions, utilities, industrial or business sites and any residential properties maintained in condominium and/or common ownership.

“Landscape plant” shall mean any native or exotic tree, shrub, or groundcover (excluding turf).

“Low maintenance zone” shall mean an area a minimum of ten feet wide adjacent to water courses which is planted and managed in order to minimize the need for fertilization, watering, mowing, etc.

“Person” shall mean any natural person, business, corporation, limited liability company, partnership, limited partnership, association, club, organization, and/or any group of people acting as an organized entity.

ORDINANCE NO. 2013 - 012

“Restricted Season” shall mean June 1 through September 30.

"Saturated soil" shall mean a soil in which the voids are filled with water. Saturation does not require flow. For the purposes of this chapter, soils shall be considered saturated if standing water is present or the pressure of a person standing on the soil causes the release of free water.

“Slow Release Nitrogen” shall mean nitrogen in a form which delays its availability for plant uptake and use after application, or which extends its availability to the plant longer than a reference rapid or quick release product.

“Turf,” “sod,” or “lawn” shall mean a piece of grass-covered soil held together by the roots of the grass.

"Urban landscape" shall mean pervious areas on residential, commercial, industrial, institutional, highway rights-of-way, or other nonagricultural lands that are planted with turf or horticultural plants. For the purposes of this section, agriculture has the same meaning as in §570.02, Florida Statutes.

Section 316.3. Timing of fertilizer application.

No applicator shall apply fertilizers containing nitrogen and/or phosphorus to turf and/or landscape plants during the Restricted Season, to saturated soils, or during a period in which a Flood Watch or Warning, or a Tropical Storm Watch or Warning, or a Hurricane Watch or Warning is in effect for any portion of Indian River County, issued by the National Weather Service, or if heavy rain is likely.

Section 316.4. Fertilizer-free zones.

Fertilizer shall not be applied within ten feet of any pond, stream, watercourse, lake, canal, or wetland as defined by the Florida Department of Environmental Protection (Chapter 62-340, Florida Administrative Code) or from the top of a seawall. If more stringent Indian River County Code regulations apply, this provision does not relieve the requirement to adhere to the more stringent regulations. Newly planted turf and/or landscape plants may be fertilized in this zone only for a 60-day period beginning thirty days after planting if needed to allow the plants to become well established. Caution shall be used to prevent nutrients from being directly deposited into the water.

Section 316.5. Low maintenance zones.

A voluntary ten foot low maintenance zone is strongly recommended, but not mandated, from any pond, stream, water course, lake, wetland or from the top of a seawall. A swale/berm system is recommended for installation at the landward edge of this low maintenance zone to capture and filter runoff. If more stringent Indian River County Code regulations apply, this provision

ORDINANCE NO. 2013 - 012

does not relieve the requirement to adhere to the more stringent regulations. Notwithstanding the voluntary nature of the above sentences, no mowed or cut vegetative material may be deposited or left remaining in this zone or deposited in the water. Care should be taken to prevent the overspray of aquatic weed products in this zone.

Section 316.6. Fertilizer content and application rates.

(a) No fertilizer containing phosphorous shall be applied to turf or landscape plants in Indian River County unless a soil or plant tissue deficiency is verified by a University of Florida, Institute of Food and Agriculture Sciences, approved testing methodology. In the case that a deficiency has been verified, the application of a fertilizer containing phosphorous shall be in accordance with the rates and directions for the Central Region of Florida as provided by Rule 5E-1.003(2), Florida Administrative Code. Deficiency verification shall be no more than 2 years old. However, recent application of compost, manure, or top soil shall warrant more recent testing to verify current deficiencies.

(b) The nitrogen content of fertilizer applied to turf or landscape plants within Indian River County shall contain at least 50% slow release nitrogen per guaranteed analysis label.

(c) Fertilizers applied to an urban lawn or turf within Indian River County shall be applied in accordance with requirements and directions set forth on the label or tag for packaged fertilizer products, or in the printed information accompanying the delivery of bulk fertilizer products, as provided by Rule 5E-1.003(2), Florida Administrative Code, *Labeling Requirements For Urban Turf Fertilizers*. All packaged and bulk fertilizer products sold in Indian River County shall be sold in packages with labels or tags, or, if sold in bulk, be accompanied by printed information, which complies with the requirements of Rule 5E-1.003(2), Florida Administrative Code.

(d) Fertilizer containing nitrogen or phosphorus shall not be applied before seeding or sodding a site, and shall not be applied for the first 30 days after seeding or sodding, except when hydro-seeding for temporary or permanent erosion control in an emergency situation (wildfire, etc.), or in accordance with the Stormwater Pollution Prevention Plan for that site.

Section 316.7. Application practices.

(a) Spreader deflector shields are required when fertilizing via rotary (broadcast) spreaders. Deflectors must be positioned such that fertilizer granules are deflected away from all impervious surfaces, fertilizer-free zones and water bodies, including wetlands.

(b) Fertilizer shall not be applied, spilled, or otherwise deposited on any impervious surfaces.

(c) Any fertilizer applied, spilled, or deposited, either intentionally or accidentally, on any impervious surface shall be immediately and completely removed to the greatest extent practicable.

ORDINANCE NO. 2013 - 012

(d) Fertilizer released on an impervious surface must be immediately contained and either legally applied to turf or any other legal site, or returned to the original or other appropriate container.

(e) In no case shall fertilizer be washed, swept, or blown off impervious surfaces into stormwater drains, ditches, conveyances, or water bodies.

Section 316.8. Management of grass clippings and vegetative materials.

In no case shall grass clippings, vegetative material, and/or vegetative debris be washed, swept, or blown off into stormwater drains, ditches, conveyances, water bodies, wetlands, or sidewalks or roadways. Any material that is accidentally so deposited shall be immediately removed to the maximum extent practicable.

Section 316.9. Exemptions.

The provisions set forth above in this chapter shall not apply to:

(a) bona fide farm operations as defined in the Florida Right to Farm Act, § 823.14, Florida Statutes;

(b) other properties not subject to or covered under the Florida Right to Farm Act that have pastures used for grazing livestock;

(c) any lands used for bona fide scientific research, including, but not limited to, research on the effects of fertilizer use on urban stormwater, water quality, agronomics, or horticulture.;

(d) golf courses when landscaping is performed within the provisions of the Florida Department of Environmental Protection document, “Best Management Practices for the Enhancement of Environmental Quality on Florida Golf Courses”, these provisions shall be followed when applying fertilizer to golf course practice and play areas;

(e) athletic fields at public parks and school facilities that apply the concepts and principles embodied in the Florida Green BMPs, while maintaining the health and function of their specialized turf areas;

(f) vegetable gardens owned by individual property owners or a community, and trees grown for their edible fruit.

Section 316.10. Training.

(a) Within the time period set forth in section 316.12 of this Chapter, all Commercial Fertilizer Applicators and Institutional Fertilizer Applicators within Indian River County shall abide by and successfully complete the six-hour training program in the “Florida-friendly Best

ORDINANCE NO. 2013 - _____

Management Practices for Protection of Water Resources by the Green Industries” offered by the Florida Department of Environmental Protection through the University of Florida Extension “Florida-Friendly Landscapes” program, or an approved equivalent.

(b) Private, non-commercial applicators are encouraged to follow the recommendations of the University of Florida Institute of Food and Agriculture Sciences Florida Yards and Neighborhoods program when applying fertilizers.

Section 316.11. General education program.

The Public Works Department shall have an employee who shall address issues pertaining to this Chapter. This employee shall implement a program to inform the general public of the requirements of this chapter, which program shall include, among other things, informative postings on the County website, printing and distributing informative brochures and other print materials, and speaking engagements at community associations, civic organizations, etc. The program shall also include, to the extent practicable, use of any materials from the Be Floridian program and coordination and collaboration with University of Florida Institute of Food and Agriculture Sciences educational activities. Any claimed or alleged deficiency in the County’s general education program shall not constitute a defense to any action brought to enforce the provisions of this chapter.

Section 316.12. Licensing of commercial fertilizer applicators.

(a) No later than December 31, 2013, all Commercial Fertilizer Applicators within Indian River County, shall abide by and successfully complete training and continuing education requirements in the “Florida-friendly Best Management Practices for Protection of Water Resources by the Green Industries,” offered by the Florida Department of Environmental Protection through the University of Florida Institute of Food and Agriculture Sciences “Florida-friendly Landscapes” program, or an approved equivalent program, prior to obtaining an Indian River County Local Business Tax Certificate for any category of occupation which may apply any fertilizer to turf and/or landscape plants. Commercial Fertilizer Applicators shall provide proof of completion of the program to the Indian River County Tax Collector’s Office within 180 days of the effective date of this ordinance.

(b) After December 31, 2013, all Commercial Fertilizer Applicators within Indian River County shall have and carry in their possession at all times when applying fertilizer, evidence of certification by the Florida Department of Agriculture and Consumer Services as a Commercial Fertilizer Applicator per Rule 5E-14.117(18), Florida Administrative Code.

(c) All businesses applying fertilizer to turf and/or landscape plants (including but not limited to residential lawns, golf courses, commercial properties, and multi-family and condominium properties) must ensure that at least one employee has a “Florida-friendly Best Management Practices for Protection of Water Resources by the Green Industries” training certificate prior to the business owner obtaining a Local Business Tax Certificate. Owners for any category of

ORDINANCE NO. 2013 - 012

occupation which may apply any fertilizer to turf and/or landscape plants shall provide proof of completion of the program to the Indian River County Tax Collector's Office.

Section 316.13. Enforcement.

This chapter may be enforced by the Code Enforcement Officer in the Public Works Department who is devoted to issues pertaining to this Chapter, pursuant to Chapter 162, Florida Statutes, and §103.07 of this Code. In addition, this chapter may be enforced by the Environmental Control Officer pursuant to Chapter 85-427, Special Acts, Laws of Florida, and §303.14 of this Code. Penalties and remedies for violations shall be as set forth in §100.05 of this Code, and, to the extent applicable, Chapter 85-427, Special Acts, Laws of Florida. Funds generated by penalties imposed under this section shall be used by Indian River County for the administration and enforcement of §403.9337, Florida Statutes, and the corresponding sections of this chapter, and to further water conservation and nonpoint pollution prevention activities.

Section 316.14. References to state law.

Any references in this chapter to Florida Statutes, rules or regulations shall refer to such statutes, rules or regulations, as amended from time to time.

Section 316.15. Applicability.

This chapter shall be applicable to and shall regulate any and all applicators of fertilizer and areas of application of fertilizer within the area of Indian River County, unless such applicator is specifically exempted; provided, however, that this chapter shall not apply within the limits of any municipality which has adopted an ordinance regulating the same subject matter. This chapter shall be prospective only, and shall not impair any existing contracts.

Section 4. Severability.

If any part of this ordinance is held to be invalid or unconstitutional by a court of competent jurisdiction, the remainder of this ordinance shall not be affected by such holding and shall remain in full force and effect.

Section 5. Codification.

It is the intention of the Board of County Commissioners that the provisions of this ordinance shall become and be made part of the Indian River County Code, and that the sections of this ordinance may be renumbered or re-lettered and the word ordinance may be changed to section, article or such other appropriate word or phrase in order to accomplish such intention.

ORDINANCE NO. 2013 - 012

Section 6. Directing County Attorney's Office to Post Summary on County Website.

The County Attorney's Office is directed to post a summary of this ordinance on the County's website within 15 days of the filing of this ordinance with the Florida Department of State.

Section 7. Effective Date.

This ordinance shall become effective 45 days after the filing of the ordinance with the Florida Department of State.

This ordinance was advertised in the Vero Beach Press Journal, on the 8th day of July, 2013, for a public hearing to be held on the 18th day of July, 2013, and on the 10th day of August, 2013 for an additional public hearing to be held on the 20th day of August, 2013, at which time it was moved for adoption by Commissioner Solari, seconded by Commissioner O'Bryan, and adopted by the following vote:

Chairman Joseph E. Flescher	<u>AYE</u>
Vice Chairman Wesley S. Davis	<u>AYE</u>
Commissioner Peter D. O'Bryan	<u>AYE</u>
Commissioner Bob Solari	<u>AYE</u>
Commissioner Tim Zorc	<u>AYE</u>

The Chairman thereupon declared the ordinance duly passed and adopted this 20th day of August, 2013.



**BOARD OF COUNTY COMMISSIONERS
INDIAN RIVER COUNTY, FLORIDA**

By: Joseph E. Flescher
Joseph E. Flescher, Chairman

ATTEST: Jeffrey R. Smith, Clerk of Court
and Comptroller

Approved as to form and legal sufficiency:

By: [Signature]
Deputy Clerk

[Signature]
Dylan Reingold, County Attorney

EFFECTIVE DATE: This ordinance was filed with the Florida Department of State on the ____ day of _____, 2013.