

Alignment - (29) PROFILE
 HORZ SCALE =20
 VERT SCALE =5

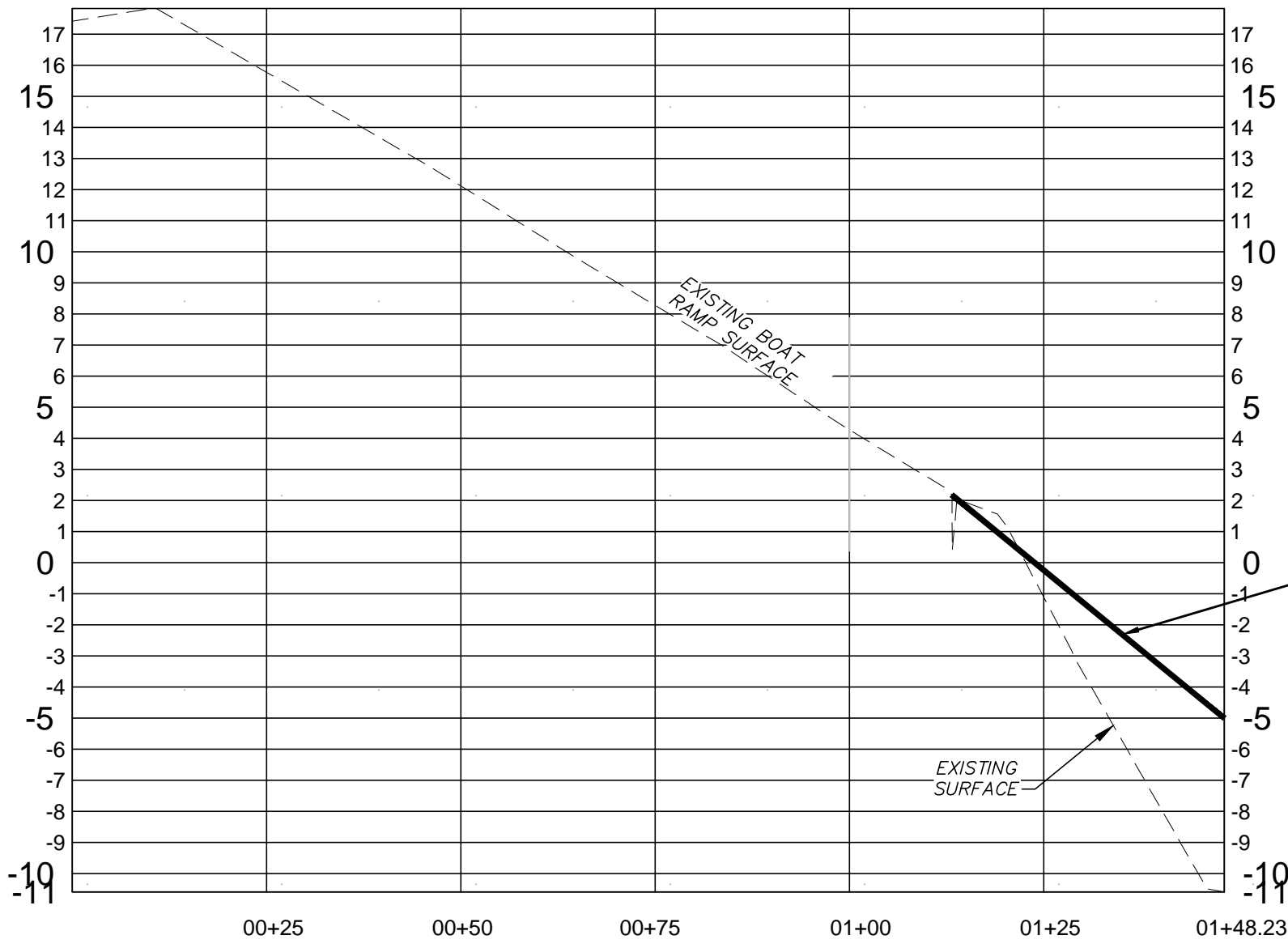

T.B.M.
 RAILROAD SPIKE
 IN 15" OAK
 N: 822871.96
 E: 961643.94
 EL: 20.00 M.L.W.
 EL: 18.21 NAVD88

LEGEND	
PROPERTY LINE	—
CONCRETE MONUMENT FOUND	□ CMF
PROPERTY ID NUMBER	PIN
NOW OR FORMERLY	N/F
TEMPORARY BENCHMARK SET	⊕ T.B.M.
CONTOUR LABEL (EXISTING)	(-5)
ASPHALT SURFACE	[Pattern]
CONCRETE SURFACE	[Pattern]

GSWCC GEORGIA SOIL AND WATER CONSERVATION COMMISSION
 ANTHONY T. ALLEN
 Level II Certified Design Professional
 CERTIFICATION NUMBER 0000044936
 ISSUED 04/21/2016 EXPIRES 04/21/2019

NO.	REVISION DESCRIPTION	BY	DATE

811
 Know what's below.
 Call before you dig.

GRAPHIC SCALE: 1"=20'-0"

EFFINGHAM COUNTY BOARD OF COMMISSIONERS PUBLIC WORKS

105 HERBERT AFB SOUTH
 SPRINGFIELD, GA 31789
 PH: (912) 754-2141
 FX: (912) 754-9969

SITE DEVELOPMENT PLAN
ABERCORN CREEK BOAT LANDING
 BOAT RAMP IMPROVEMENTS
 EFFINGHAM COUNTY, GEORGIA
 Prepared for:
 EFFINGHAM COUNTY BOARD OF COMMISSIONERS

PROJECT NO.:	11-014
DRAWN BY:	ATA
DESIGNED BY:	WAS
SURVEYED BY:	EMC
CHECKED BY:	ATA
SCALE:	1" = 20'
DATE:	OCT 2016

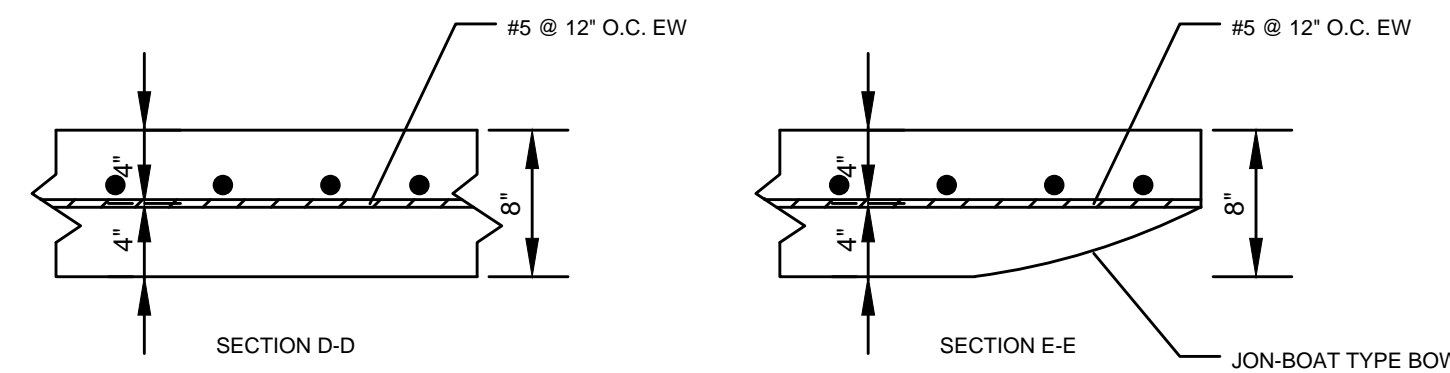
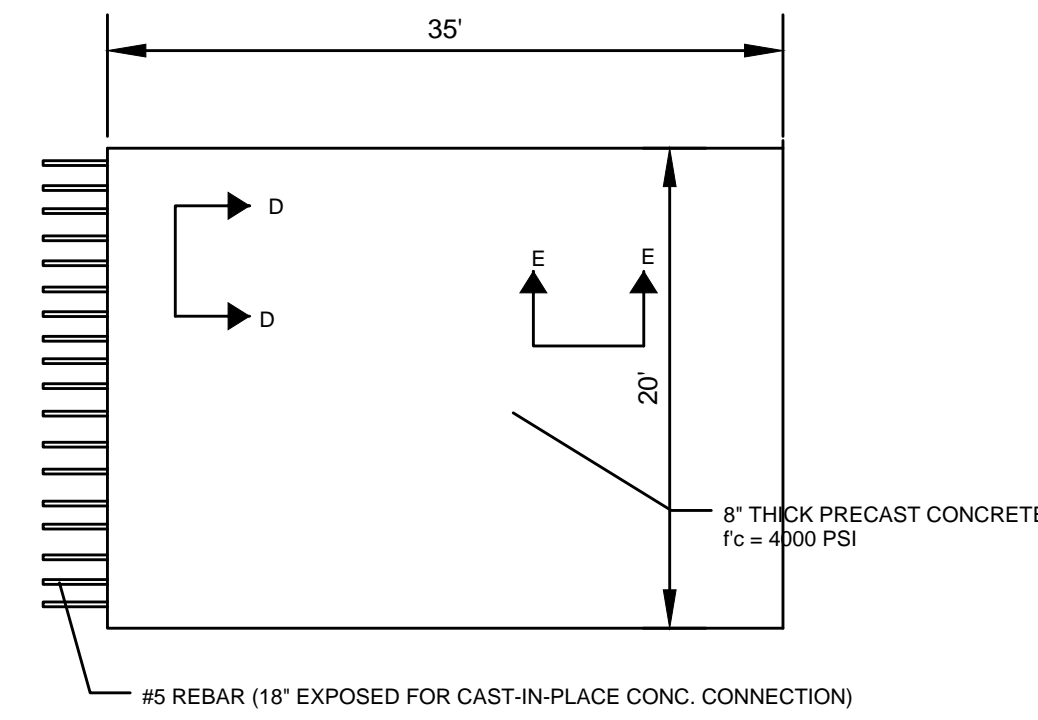

SUBMERGED BOAT RAMP SECTION (PUSH SLAB)

NOT TO SCALE

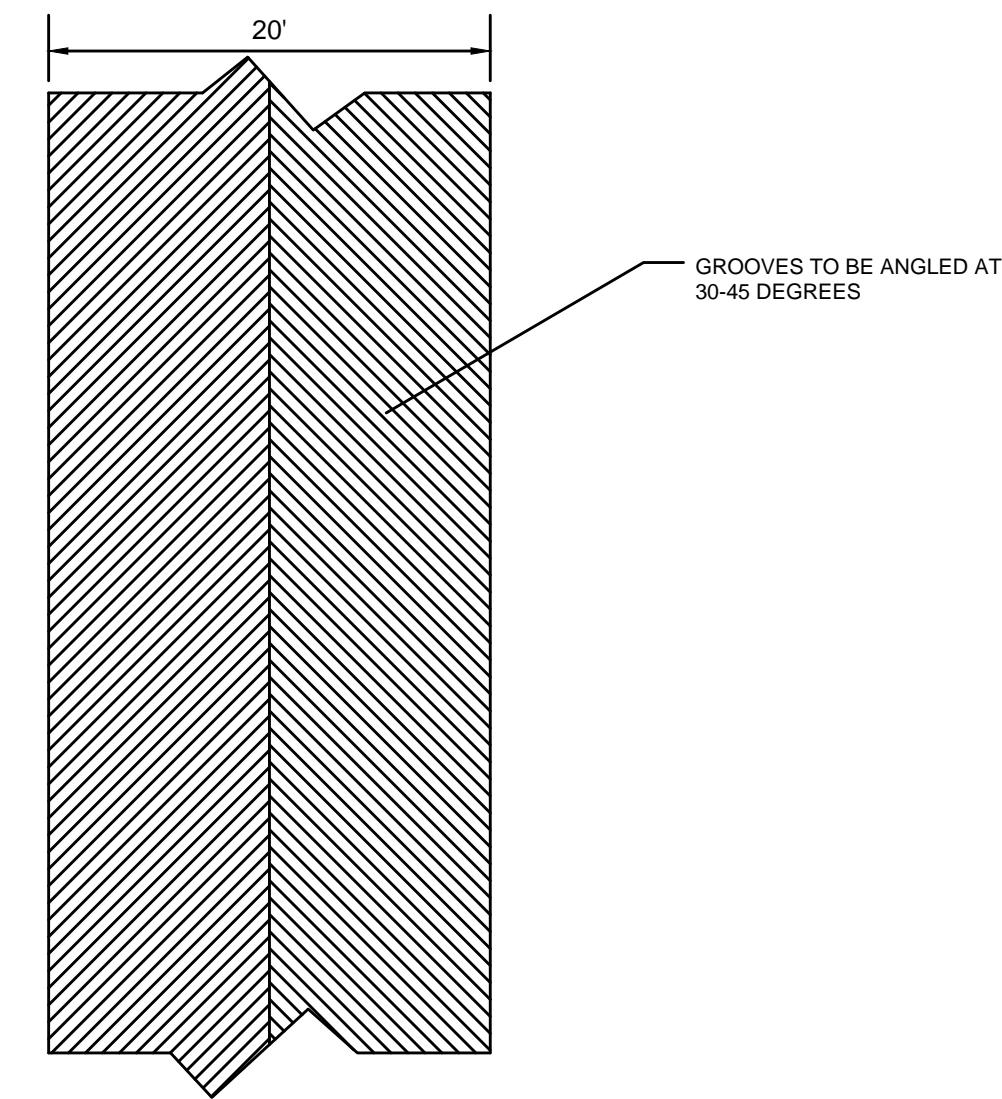

**PLAN VIEW OF PUSH SLAB
(WITH CHEVRON-STYLE GROOVING)**

NOT TO SCALE

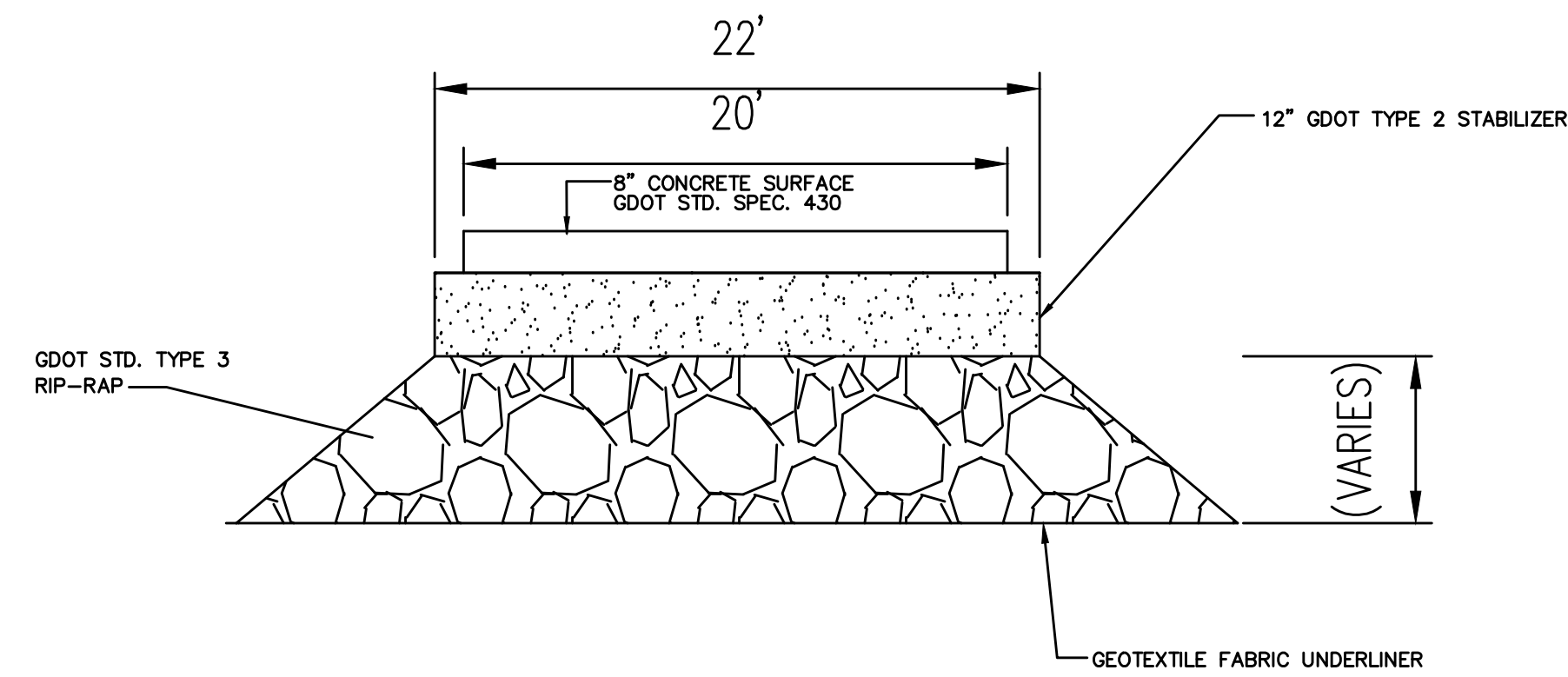

BOAT RAMP CROSS SECTION

NOT TO SCALE

NO.	REVISION DESCRIPTION	BY	DATE



Know what's below.
Call before you dig.



GRAPHIC SCALE: 1"=20'-0"

EFFINGHAM COUNTY
BOARD OF
COMMISSIONERS
PUBLIC WORKS

105 HERRING ISLAND SOUTH
SPRINGFIELD, GA 31309
PH: (912) 754-2141
FX: (912) 754-9959



CONSTRUCTION DETAILS

ABERCORN CREEK BOAT LANDING
BOAT RAMP IMPROVEMENTS
EFFINGHAM COUNTY, GEORGIA

Prepared for:
EFFINGHAM COUNTY BOARD OF COMMISSIONERS

PROJECT NO.:	15-2012
DRAWN BY:	ATA
DESIGNED BY:	WAS
SURVEYED BY:	EMC
SURVEY DATE:	OCT 2016
CHECKED BY:	ATA
SCALE:	N.T.S.
DATE:	OCT 2016

SHEET
2
OF 2

GSWCC GEORGIA SOIL AND WATER CONSERVATION COMMISSION

ANTHONY T. ALLEN
Level II Certified Design Professional

CERTIFICATION NUMBER 0000044936
ISSUED 04/21/2016 EXPIRES 04/21/2019