

INVITATION TO BID



CITY OF CALLAWAY HUGH THOMAS DRIVE IMPROVEMENTS BID NO: PW2020-01

ADVERTISED: The Bay County News Herald, Friday, December 13, 2019

PREBID MEETING: N/A

BID DEADLINE: 2:00 p.m. Thursday, January 9, 2020

BIDS/PROPOSALS ARE TO BE SUBMITTED TO:

CITY OF CALLAWAY
ATTN: JANICE L. PETERS, CITY CLERK
6601 EAST HWY. 22
CALLAWAY, FL 32404

BID OPENING: 2:15 p.m. Thursday, January 9, 2020
Callaway Arts & Conference Center, 500 Callaway Park Way

ATTACHMENTS: Notice of Request for Bids/Proposals
General Instructions and Conditions
Special Instructions and Conditions
Minimum Technical Specifications
Sample Agreement
Bid Forms (**To be submitted with bid.**):
Bid/Certification Form
Public Entity Crimes Statement
Drug Free Workplace Certification
Proprietary/Confidential Information Form
Certification Regarding Debarment
Trench Safety Compliance Certification Form
Anti-Collusion Clause Form

Janice L. Peters, MMC, City Clerk

INSTRUCTIONS TO BIDDERS/PROPOSERS

Qualified firms are invited to submit a Bid/Proposal to the **CITY OF CALLAWAY** for the **LIFT STATION HUGH THOMAS DRIVE IMPROVEMENTS, BID NO: PW2020-01**, by replying to the enclosed specification. In order for the Bid/Proposal to be considered, complete all items in this specification.

All Bids/Proposals must include one **(1) unbound original** and **five (5) copies** and be addressed to:

CITY OF CALLAWAY
ATTN: CITY CLERK
6601 East Hwy. 22
CALLAWAY, FL 32404

Proposals must be **received** at the address listed above no later than **2:15 p.m. on Thursday, January 9, 2020**. Late Proposals will not be accepted, regardless of the reason.

Proposal envelopes must be **sealed and marked** with the RFP number, due date, and name of Proposer so as to identify the enclosed submittal. If more than one package is submitted, please mark "1 of 2", "2 of 2", etc.

INTERPRETATION OF SPECIFICATION

All questions pertaining to the terms and conditions of the scope of work of this Bid/Proposal must be submitted **in writing** via email or fax to the City Clerk as shown below:

Janice L. Peters, MMC, City Clerk
City of Callaway
6601 East Hwy. 22
Callaway, FL 32404
jpeters@cityofcallaway.com
Fax: (850) 871-2444

No oral interpretations will be made to any firm as to the meaning of specifications or any other contract documents. In accordance with Florida Statutes 287.057(23), "Respondents to this solicitation or persons acting on their behalf may not contact, between the release of the solicitation and the end of the 72-hour period following the agency posting the notice of intended award, excluding Saturdays, Sundays, and state holidays, any employee or officer of the executive or legislative branch concerning any aspect of this solicitation, except in writing to the procurement officer or as provided in the solicitation documents. Violation of this provision may be grounds for rejecting a response." Questions must be submitted as referenced above.

All questions must be received at least five (5) calendar days prior to the scheduled opening of Bids/Proposals. Any interpretation of the Bid/Proposal terms, conditions, and/or specification, if made, will be only by Addendum issued by the City Clerk. A copy of such Addendum will be posted to the City's website at www.cityofcallaway.com and mailed to each proposer that received a copy of the advertisement of the Request for Bids/Proposals. **IT IS THE RESPONSIBILITY OF THE BIDDER/PROPOSER TO CHECK THE CITY'S WEBSITE FOR ANY ADDENDUMS PRIOR TO SUBMITTING A BID/PROPOSAL.** No verbal instructions or interpretations of drawings and specifications will be made other than indicated above.

The City reserves the right to reject any or all proposals, to waive informalities in the Bids/Proposals and to re-advertise for Bids/Proposals. The City also reserves the right to separately accept or reject any item or items of a Bid/Proposal and to award and/or negotiate a contract in the best interest of the City.

TABLE OF CONTENTS



CITY OF CALLAWAY HUGH THOMAS DRIVE IMPROVEMENTS BID NO: PW2020-01

	<u>Total Pages Per Section</u>
SPECIAL INSTRUCTIONS AND CONDITIONS.....	2
GENERAL INSTRUCTIONS AND CONDITIONS	9
MINIMUM TECHNICAL SPECIFICATIONS	38
DRAWINGS	10
AGREEMENT FOR CONTRACTOR SERVICES	9
BID/PROPOSAL CHECKLIST	1
BID CERTIFICATION FORM.....	2
PUBLIC ENTITY CRIMES STATEMENT	2
DRUG-FREE WORKPLACE CERTIFICATION.....	1
PROPRIETARY/CONFIDENTIAL INFORMATION FORM	1
CERTIFICATION REGARDING DEBARMENT	1
TRENCH SAFETY COMPLIANCE CERTIFICATION FORM	1
ANTI-COLLUSION CLAUSE FORM.....	1

**CITY OF CALLAWAY
SPECIAL INSTRUCTIONS AND CONDITIONS**

**HUGH THOMAS DRIVE IMPROVEMENTS
BID NO: PW2020-01**

* Note: The GENERAL INSTRUCTIONS AND CONDITIONS (attached hereto) apply, except as set forth below, for this Bid.

A. **Description:** () See Attached (X) As Follows

Project includes demolition of an existing roadway crossing, replacing 30” and 18” reinforced concrete pipe and concrete inlets at a road crossing. Work also includes cleaning out an existing stormwater pond. The work includes no new asphalt, only concrete work.

B. **Specifications:** (X) See Attached () As follows:

See attached Minimum Technical Specifications

C. **Contract/Agreement Required:** () None (X) As follows:

See attached Agreement

D. **Items to be submitted with Bid:** () None (X) As follows:

- Bid/Certification Form(s) with signature page(s),
- Public Entity Crimes Statement,
- State of Florida or County Contractor License/Certification Copy
- Drug Free Workplace Certification,
- One (1) unbound original with five (5) copies of the bid submittal,
- List of Subcontractors, if applicable, and
- List of three (3) references for similar type work with contact information.
- Certification Regarding Debarment
- Trench Safety Compliance Certification Form
- Proprietary/Confidential Information Form
- Anti-Collusion Clause Form

E. **Deadline and place for submission of Bids:**

2:00 p.m., THURSDAY, JANUARY 9, 2020 (BID DEADLINE)

City Hall

6601 East Hwy. 22

Callaway, FL 32404

F. **Time and place for OPENING of Bids:**

2:15 p.m., THURSDAY, JANUARY 9, 2020

City of Callaway ARTS & CONFERENCE CENTER - 500 CALLAWAY PARK WAY.

G. Insurance Requirements: () None (X) As follows:

	<u>Minimum Coverage</u>
<u>Property Damage:</u>	\$ <u>500,000</u>
<u>General Liability:</u>	\$ <u>1,000,000/2,000,000</u>
<u>Automobile Liability:</u>	\$ <u>1,000,000/2,000,000</u>
<u>Workers' Compensation:</u>	\$ <u>Statutory Limit*</u>

Note: Insurance Certificate must be provided by Successful Bidder upon execution of Agreement. City is to be listed on the bidder's/proposer's Certificate of Insurance as additionally insured and certificate holder in order for the City to be notified if the insurance is canceled or modified.

H. Bond Requirements: () None (X) As follows:

	<u>Amount of Bond</u>
Bid Bond	\$ _____ or <u>5</u> % of Bid
Performance Bond	\$ _____ or <u>100</u> % of Bid
Payment Bond	\$ _____ or <u>N/A</u> % of Bid
Construction Bond	\$ _____ or <u>N/A</u> % of Bid
Other: _____	\$ _____ or <u>N/A</u> % of Bid

I. Number of Copies of Bid Forms with original signature(s) Required:

One (1) unbound original, with notarized Signatures, plus five (5) copies

NOTICE:

Proposals may be rejected if all documents are not complete and executed, and the numbers of copies specified/requested of each are not submitted with the proposal.

GENERAL INSTRUCTIONS AND CONDITIONS

(1) NOTICE TO BIDDERS/PROPOSERS

The following general instructions and conditions apply to all Requests for Bids/Proposals unless modified by the provisions set forth in the “**Special Instructions and Conditions**” attached hereto. If there is a conflict between the “Special Instructions and Conditions” and these “General Instructions and Conditions,” the provisions in the Special Instructions and Conditions will apply. **Note: the General Instructions and Conditions and the Special Instructions and Conditions are periodically revised; potential Bidders/Proposers should read both carefully prior to submitting a Bid/Proposal. The attached Special Instructions and Conditions apply only to this Bid/Proposal.**

(2) SUBMITTAL OF BIDS/PROPOSALS

Qualified businesses or individuals requesting consideration must submit a complete Bid/Proposal with any/all attachments in a sealed package clearly marked with the **name** and **number of the Bid/Proposal**, to the attention of the City Clerk, prior to closing time at the address shown in the **Special Instructions and Conditions** attached hereto. If not so marked as to this wording, sealed and/or received by the closing time, the Bid/Proposal will not be accepted. Bid/Proposal packages, additional information regarding this Bid/Proposal, or the bidding procedures may be obtained by contacting the City Clerk, 6601 East Hwy. 22, Callaway, FL 32404, (850) 215-6694.

It shall be the sole responsibility of the Bidders/Proposers to have their Bid/Proposal delivered on or before the closing time and date stated in the **Special Instructions and Conditions**. Any Bids/Proposals received after the stated time and/or due to delays caused by mail or courier delivery, or any other reason, shall not be opened or otherwise considered, and will be returned at the bidder's/proposer's expense.

Bids/Proposals shall be opened and publicly announced at the City Clerk's Office, City Hall, 6601 East Hwy. 22, Callaway, Florida, after closing of Bids/Proposals, unless otherwise specified in the Special Instructions and Conditions.

(3) SPECIFICATIONS AND REQUIREMENTS

The detailed specifications and additional requirements relating to this Bid/Proposal are set forth in the Special Instructions and Conditions attached hereto.

SILENCE OF SPECIFICATIONS: The apparent silence of any specification as to any details or any omission of a detailed description concerning any point shall be regarded as meaning that only the best construction practices are to prevail and that only new materials of first quality and correct type, size and design are to be used. All workmanship is to be first quality. All interpretations of specifications shall be made accordingly by the City.

(4) BID/PROPOSAL FORM

Bidders/Proposers shall complete, sign and furnish the “Bid Certification Form”, together with the forms, specifications and materials required in the “Special Instructions and Conditions” or any exhibits attached hereto. This will include a properly executed Drug-Free Workplace Certification, and a Sworn Statement on Public Entity Crimes Form, pursuant to Section 287.133(3)(a), Florida Statutes. The minimum number of complete Bid/Proposal packages to be submitted is set forth in the Special Instructions and Conditions.

If the "Special Instructions and Conditions" include a "Scope of Work" provision, and/or provide for a supplemental and or implementing agreement, the City reserves the right to modify the "Scope of Services." Further, the terms and conditions of any such agreement shall be modified prior to execution by the City, if such modifications are determined to be in the best interest of the City.

Bids/Proposals may be considered non-responsive, at the sole option of the City, and may be rejected if they include omissions, alterations of form, additions not called for, conditions or limitations, unauthorized alternate Bids/Proposals, submission of less than the number of bid packages requested, or other irregularities of any kind.

Unless otherwise stated, the price(s) set forth in the Bid/Proposal include(s) all costs and expenses for labor, equipment, materials, commissions, transportation charges and expenses, handling material inspection, and patent fees and royalties, together with any and all other costs and expenses for providing the service, equipment, materials or performing and completing the work as shown according to the plans and specifications herein.

If quotations are requested for the various items of work, they are intended to establish a total price for providing the materials, equipment, services, or completing the work in its entirety. If the Bidder/Proposer determines that the cost for any item of work has not been established by the Proposal Form, the cost for that work is to be included in other applicable Bid/Proposal item(s), so that the Bid/Proposal reflects the total price for completing that work in its entirety.

In the event of a discrepancy between a unit bid price and an extension, the unit bid price will govern. Written prices shall govern over figures.

(5) CLARIFICATION AND ADDENDA

Each Bidder/Proposer shall examine all Bid/Proposal documents and shall judge all matters relating to the adequacy and accuracy of such documents. Any inquiries, suggestions or requests concerning the interpretation, clarification or additional information pertaining to this Invitation to Bid/Request for Bid/Proposal will be accepted by the City Clerk up to and including five (5) working days prior to the closing date and time stated herein. The issuance of a written addendum signed by the City Clerk is the only official method whereby interpretation, clarification or additional information can be given. The City shall not be responsible for oral interpretations given by any City employee, representative or others. If any addenda are issued, the City will attempt to notify all known prospective Bidders/Proposers. However, it shall be the responsibility of each Bidder/Proposer, prior to submitting a Bid/Proposal, to contact the City Clerk's Office to determine if addenda were issued, and to make such addenda a part of the Bid/Proposal. If an addendum has been issued, and was not incorporated in the Bid/Proposal documents submitted by Bidder/Proposer, the Bid/Proposal may not be accepted or considered by the City.

(6) MANUFACTURER'S NAMES AND APPROVED EQUIVALENTS

Unless otherwise specifically stated in the Special Instructions and Conditions, any manufacturer's names, trade names, brand names, catalog numbers, or similar information listed in a specification, are for the purpose of information and illustration, and are not intended to restrict the submission of alternates meeting minimum specifications. The Bidder/Proposer may offer the same or any alternate for which the Bidder/Proposer is an authorized representative, which meets or exceeds the specifications for any item. If a manufacturer's name or model is included in the specification, and a Bid/Proposal is based on alternate products or services which Bidder/Proposer maintains is equivalent and meets or exceeds specifications, Bidder/Proposer is to indicate on the Bid/Proposal Form the manufacturer's name and related information of the alternate; including any deviation from the specifications. Unless expressly noted on the Bid/Proposal that an alternate is being

proposed, and the specification includes a specific manufacturer's model or brand, the Bid/Proposal will be considered as a quotation for the item(s) stated in the specifications.

(7) INFORMATION AND DESCRIPTIVE LITERATURE

Bidders/Proposers must furnish all information requested in the Bid/Proposal packet including but not limited to any sketches, plans, designs, specification, and descriptive literature regarding the product(s)/service(s) being offered. Bids/Proposals which do not comply with these requirements are subject to rejection. Reference to submission of documentation or materials with a previous Bid/Proposal will not satisfy this provision.

(8) BONDS/INSURANCE

If the Bid/Proposal is accepted by the City, it will become a binding contract on both parties. If a bond or cashiers/certified check is required as a bond, it shall be submitted with the Bid/Proposal. If the undersigned shall fail to deliver or perform, or if applicable, execute a contract if provided for herein, then the City may, at its option, determine that the undersigned has abandoned the award/contract, and thereupon such acceptance of the Bid/Proposal and/or award shall be null and void, and any cashiers/certified check or bond accompanying this Bid/Proposal shall be forfeited to and become the property of the City. The full amount of said check, or if a bond, the full amount of such bond, shall be paid to the City as partial liquidated damages; otherwise, any bond or cashiers/certified check accompanying this Bid/Proposal shall be returned to the undersigned within 30 calendar days from the date of award, or if provisions for a Notice to Proceed are included, from the date of the Notice to Proceed.

If a bid or proposal bond is required, the bonds of unsuccessful Bidders/Proposers will be returned within 30 calendar days of the Bid/Proposal due date, except as set forth below.

If a proposal is subject to the Competitive Negotiations Act, the bonds will be returned within 60 days of the proposal due date, except for the bond of the 3 highest ranked proposers. Within 30 days of execution of a contract, bonds from the remaining unsuccessful proposers will be returned.

Bid bond, if required, will be returned within 30 calendar days of delivery/acceptance of the item(s) bid or service(s) provided, unless a standard payment and performance bond is required. When a standard Payment and Performance Bond is required, the bid bond of the successful Bidder/Proposer will be returned within 30 calendar days from the date of the Notice to Proceed.

In the event a bid is awarded, a proposal is accepted, and/or a contract is executed, and the Bidder/Proposer chooses not to proceed, or fails to perform for any reason, the bond will be forfeited and retained by the City as partial liquidated damages. Future Bids/Proposals will not be accepted for consideration from the Bidder/Proposer for five (5) years, or such shorter period as the City Commission may determine.

In the event an award/selection is not made within 90 days after the Bid/Proposal due date and the City does not return all bonds, upon 30 business days written request, a bidder/proposer may withdraw their bid or proposal from consideration, and obtain a refund of the Bid/Proposal bond.

All Awards will be subject to presentation of any required performance bond or certificate of insurance prior to any purchase authorizations, agreements, contract documents, or delivery. The Bidder/Proposer shall maintain any performance bonds or insurance coverage set forth in the Special Instructions and Conditions, at its own expense. If insurance is required, the City is to be listed on the bidder/proposer's Certificate of Insurance as an additional insured and certificate holder in order that the City will be notified if the insurance is canceled or modified. The certificate shall also list the name of the project/service/equipment purchased, and the expiration date of the policy. At the City's option, an award may be canceled and any bid bond forfeited if any required performance bond or insurance certificate is not delivered within 21 calendar days of the date of award.

***Note:** The provisions of this section are in addition to and not a replacement for, any Bid/Proposal and/or performance bond required in the Special Instructions and Conditions. The foregoing provisions are intended to be in addition to any other legal remedy available to the City for non-performance by a Bidder/Proposer subsequent to the acceptance and/or award of a bid or proposal.*

(9) SERVICE AND WARRANTY

If any warranty repair or replacement service is requested in the Special Instructions and Conditions, any deviation or limitation from the requirements is to be expressly stated on the Bid Request for Proposal Certification Form.

If the service or product provided to the City pursuant to the bid consists of computer hardware, software or firmware, the Bidder/Proposer warrants that said product will accurately process/or reflect data from, into and between the twentieth and twenty-first centuries, including leap-year calculations.

(10) CONTRACT FORMS

Any agreement or contract resulting from the acceptance of a Bid/Proposal shall be on forms either supplied by or approved by the City, and shall contain, as a minimum, applicable provisions of the Invitation to Bid/Request for Proposal, and the Bid/Proposal documents to be submitted by Bidder/Proposer, including the Special Instructions and Conditions, General Instructions and Conditions, and all attachments therewith. The City reserves the right to reject any Bid/Proposal or resulting agreement which does not conform to the Invitation to Bid/Proposal and, if applicable, any City requirement relating to such an Agreement.

The City reserves the right to extend any contract or agreement for an additional period of not more than ninety (90) days beyond the original expiration date. Prices in effect on the last day of the contract shall remain in effect for the contract extension period. Additional extensions shall be subject to agreement of both parties.

The successful Bidder/Proposer will be required to execute any resulting agreement and provide any bonds or insurance certificates required within 10 days of contract execution. Failure to timely execute the necessary bond or insurance certificate will result in cancellation of an award, with no further obligation by the City.

This Bid/Proposal is subject to the appropriation of funds in an amount sufficient to allow continuation of the City's performance in accordance with the terms and conditions of this Bid/Proposal for each and every fiscal year in which this Bid/Proposal is executed and entered into. If funds are not appropriated/available, the City shall provide prompt written notice to the selected Bidder/Proposer that effective thirty (30) days after giving such notice, or upon the expiration of the time for which funds were appropriated, whichever occurs first, the City will thereafter be released of all further obligations related to the Bid/Proposal and/or award.

(11) BID/PROPOSAL EXPENSES

All expenses for preparing and submitting Bids/Proposals to the City are to be borne by the Bidder/Proposer.

(12) VARIANCES

Any variance whatsoever from the Bid/Proposal Specifications are to be clearly identified on the Bid/Proposal form. Acceptance of any proposed variations will be at the sole discretion of the City.

(13) CONFLICT OF INTEREST

The award of a bid or acceptance of proposal is subject to Chapter 112, Florida Statutes. All Bidders/Proposers must disclose with their Bid/Proposal the name of any officer, director, or agent who is a city official or employee, or a member of an official's or employee's immediate family. Further, Bidders/Proposers must disclose the name of any city official or employee, or a member of an official's or employee's immediate family, who owns directly or indirectly an interest of ten percent (10%) or more in the bidder's/proposer's firm or related business.

(14) DELIVERY

All items provided pursuant to an award are to be delivered prepaid to the City Clerk's Office, 6601 East Hwy. 22, Callaway, Florida 32404-2041, unless a different location is specified in the Special Instructions and Conditions. All delivery charges are to be included in the Bid/Proposal price. No Collect on Delivery (C.O.D.) will be accepted. Title and risk of loss or damage to all items shall be the responsibility of the Bidder/Proposer until delivered to the City.

(15) INSPECTION, ACCEPTANCE AND TITLE

All items delivered pursuant to an award are subject to inspection and review prior to acceptance by the City. Acceptance, evidenced by separately written Notice of Acceptance or full payment, will be made only after verification of compliance with all specifications. Acknowledgment of delivery and/or partial payment does not constitute acceptance.

(16) OWNERSHIP RIGHTS AND PUBLIC RECORDS LAW

Public Records Law. Bidder/Proposer acknowledges that they are familiar with the provisions of the Public Records Law of the State of Florida.

Bidder/Proposer agrees to comply with Chapter 119, Florida Statutes, and specifically per Florida Statute 119.0701, Bidder/Proposer agrees to keep and maintain public records that would be required by the City of Callaway in order to perform the services provided for in this agreement; Bidder/Proposer agrees to provide public access to any required public records in the same manner as a public agency; Bidder/Proposer agrees to protect exempt or confidential records from disclosure; Bidder/Proposer agrees to meet public records retention requirement; and Bidder/Proposer agrees that at the end of the term of this agreement, to transfer all public records to the City of Callaway and destroy any duplicate, exempt or confidential public records.

All products generated by the Bidder/Proposer for the City become the property of the City. The City may require submission of any electronic file version of reports, data, maps, or other submission of documentation produced for or as a result of this Bid/Proposal in addition to paper documents.

Further, in accordance with the Public Records Laws of the State of Florida, Section 119.0701, (2013), Contractor must:

- A. Keep and maintain public records that ordinarily and necessarily would be required by the public agency in order to perform the service.
- B. Provide the public with access to public records on the same terms and conditions that the public agency would provide the records and at a cost that does not exceed the cost provided in this chapter or as otherwise provided by law.

- C. Ensure that public records that are exempt or confidential and exempt from public records are not disclosed except as authorized by law.
- D. Meet all requirements for retaining public records and transfer, at no cost, to the public agency all public records in possession of the contractor upon termination of the contract and destroy any duplicate public records that are exempt or confidential and exempt from public record disclosure requirements. All records stored electronically must be provided to the public agency in a format that is compatible with the information technology systems of the public agency.
- E. If a contractor does not comply with a public records request, the public agency shall enforce the contract provision in accordance with the contract.

(17) RESERVED RIGHTS

The City reserves the right to reject any and all Bids/Proposals, with or without statement of cause, request resubmissions, or to waive any irregularities or technicality or negotiate modifications to any Bid/Proposal which may be in the best interest of the City.

Bidders/Proposers which do not normally engage in providing the types of commodities/services specified herein may be required to demonstrate they have sufficient financial support, equipment, and organization to ensure they can satisfactorily perform if awarded a bid/contract under the terms and conditions herein stated.

The City reserves the right to make such investigations as it deems necessary to determine the ability of any Bidder/Proposer to perform the work or service requested. Any information the City deems necessary to make such determinations shall be provided by the Bidder/Proposer upon request as a condition of further consideration of the Bid/Proposal. The applicability of all information obtained and the City's decision shall be final. By submitting a bid or proposal, Bidder/Proposer authorizes such investigation.

If the contract awarded as a result of this bid is terminated prior to the end of the term, the City reserves the right to award the balance of the contract to the next lowest responsive and responsible bidder.

(18) ADVERTISING

In submitting a Bid/Proposal, Bidder/Proposer agrees not to use the results therefrom as a part of any commercial advertising or marketing purposes without written approval of the City Manager.

(19) GOVERNMENTAL RESTRICTIONS/REQUIREMENTS

In the event any governmental restrictions are imposed which would necessitate alteration of the material, quality, workmanship, or performance of the items offered in a Bid/Proposal, it shall be the responsibility of the successful Bidder/Proposer to immediately notify the City of the specific regulation which required an alteration, and the specific alterations that will be made to the item(s) bid/proposed. The City reserves the right to accept any such alteration/substitution, including any price adjustments resulting therefrom, or to cancel the award at no expense to the City.

(20) NON-DISCRIMINATION

There shall be no discrimination as to race, sex, color, creed, handicap, or national origin in the selection, award, or operations conducted, or performance related to any bid or proposal.

(21) UNAUTHORIZED EMPLOYEES OR AGENTS

Employment of unauthorized aliens by Bidder/Proposer is considered a violation of Section 274A(e) of the Immigration and Nationality Act. If selected Bidder/Proposer knowingly employs unauthorized aliens, such action shall be cause for unilateral cancellation of this agreement and the City may recover damages from selected Bidder/Proposer resulting from such cancellation. The selected Bidder/Proposer shall be responsible for including this provision in any context with, and requiring compliance by any/all subcontracts performing for selected Bidder/Proposer relating to this agreement.

(22) OTHER GOVERNMENTAL ENTITIES - OPTIONAL APPLICATION

In the State of Florida, other Florida public entities may “piggy-back” on competitive Bid/Proposal awards under the same terms and conditions, if all parties are in agreement.

(23) LEGAL NAME

Bids/Proposals shall clearly indicate the legal name and organizational structure, business address, telephone number, and email address of the Bidder/Proposer. Bids/Proposals shall be signed above the typed or printed name and title of the individual submitting the Bid/Proposal. The signer shall warrant he/she has the authority to bind the Bidder/Proposer to the terms and conditions of the submitted Bid/Proposal.

(24) WAGES

State and Federal minimum wage and hour regulation apply to Bidder/Proposer and all subcontractors.

(25) SELECTION

The City intends to award this bid to the lowest responsive and responsible bidder or bidders. However, the City reserves the right to reject any and all Bids/Proposals. The procedures for the selection/award of Bids/Proposals are provided for by Florida Statutes and the City’s Charter, Code of Ordinances, and Administrative Policies. Generally, all Bids/Proposals are reviewed by City staff and evaluated by the City Manager, and if required by law, by a Selection Advisory Committee appointed by the City Manager. The type and price of the product(s) or service(s) being acquired determines if an award or selection may be made by the City Manager or requires City Commission approval. For information on which procedure applies to a particular Bid/Proposal contact the City Clerk.

Bids/Proposals will be evaluated based on, but not limited to, one or more of the following criteria as appropriate:

- compliance with specifications,
- price (if applicable),
- capability/adequacy of Bidder/Proposer,
- past and current projects, services or equipment provided to the City,
- delivery schedule,
- prior government projects, services or equipment provided to other jurisdictions, and
- general reputation, location and references.

Separate procedures and requirements relating to Requests for Bids/Proposals/Qualifications apply for certain grant programs and for professional services, for example the Consultants’ Competitive Negotiation Act (Florida Statute 287.055), and by the City’s Code. When the City initiates such a Request for Proposals/Qualifications, the selection process and related procedures are included in the Special Instructions and Conditions.

Pursuant to Chapter 287.087 Florida Statutes, in the event two (2) or more bids are equal with respect to price, quantity, and services, preference will be given to Bidders/Proposers which have implemented Drug-Free Workplace Programs.

Further, per 287.087(11) "If two equal responses to a solicitation or a request for quote are received and one response is from a certified minority business enterprise, the agency shall enter into a contract with the certified minority business enterprise." In addition, at the sole discretion of the City, payment terms, conditions, and other consequential information may be utilized in resolving apparent tie Bids/Proposals.

NOTE: For consideration, Bidder/Proposer must return the Bid Certification Form included in the Bid/Proposal package.

(26) INDEMNIFY

After notification of award, the successful Bidder/Proposer agrees to defend, indemnify and hold harmless the City and its officials, officers, employees, agents, and invites, from and against all claims, suits, sections, damages, or causes of action arising from any personal injury, loss of life or damage to property, sustained by reason of, or as a result of constructing, manufacturing, processing, delivery, or performance of the services or work for which the Bid/Proposal was awarded or any resulting agreement executed, and from and against any orders, judgments, or decrees which may be entered thereto, and from and against all costs, attorney's fees, expenses, and liabilities incurred in or by reason of the defense of any such claim, suit or action, and the investigation thereof. Nothing in any resulting agreement shall be deemed to affect the rights, privileges and immunities of the City of Callaway.

The selected Bidder/Proposer, without exception, shall also indemnify and hold harmless the City and its officials, employees, agents, and invites from liability of any nature or kind, including cost and expenses for or on account of any copyrighted, patented or unpatented invention, process or article manufactured or used in the performance of the contract, including its use by the City. If the selected Bidder/Proposer uses any design, device or materials covered by patent or copyright, it is mutually agreed and understood that the Bid/Proposal prices include all royalties or costs arising from the use in any way of such design, device or materials involved in the product and/or services provided to the City.

(27) MODIFICATION - AFTER AWARD

Any changes proposed by a Bidder/Proposer after an award in (a) materials used, (b) manufacturing process, (c) construction or (d) specifications, are to be submitted in writing to the City Manager prior to delivery. No changes shall be approved and binding upon the City unless evidenced by a Change Order issued and signed by the City Manager.

(28) ASSIGNMENT

Any purchase order issued pursuant to this bid invitation/request for proposal and the funds which may become due hereunder, are not assignable, except with the prior written approval of the City Manager.

(29) DISCLOSURE

Bidder/Proposer acknowledges by submitting a Bid/Proposal that all information provided to the City is part of the public domain as defined by Florida Statutes and is considered a public record. Information should not be labeled "confidential," unless specifically exempted under said Statutes, and exempts the City from any liability for releasing all information to the public, including inadvertently releasing information deemed confidential by the Bidder/Proposer.

(30) TAXES

The City is a tax-exempt Florida municipality, Federal Employment Identification Number 59-6000-284, Florida State Tax Number 37-02-008131-54C. Copies of Exemption Certificate and related information may be obtained by contacting the City Clerk, City of Callaway, 6601 East Hwy. 22, Callaway, Florida 32404-2041 or (850) 215-6694.

(31) APPLICABLE LAWS/LEGAL VENUE

All applicable laws, regulations and ordinances of the State of Florida, Bay County and the City of Callaway will apply to consideration and award of any Bid/Proposal and the performance of the Bidder/Proposer pursuant thereto, and shall be governed by the laws of the State of Florida both as to intention and performance. The venue for any action arising from the award or subsequent performance shall lie exclusively in the Circuit Court of Bay County, Florida, or the United States District Court for the Northern District of Florida, as applicable.

NOTE: ANY AND ALL PROVISIONS SET FORTH IN THE SPECIAL INSTRUCTIONS AND CONDITIONS ATTACHED HERETO, WHICH VARY FROM THESE GENERAL INSTRUCTIONS AND CONDITIONS, SHALL HAVE PRECEDENCE.

**CITY OF CALLAWAY
HUGH THOMAS DRIVE IMPROVEMENTS
BID NO: PW2020-01**

Project includes demolition of an existing roadway crossing, replacing 30” and 18” reinforced concrete pipe and concrete inlets at a road crossing. Work also includes cleaning out an existing stormwater pond. The work includes no new asphalt, only concrete work.

**MINIMUM TECHNICAL
SPECIFICATIONS**

TABLE OF CONTENTS

02200	Earthwork	6
02211	Sodding	2
02222	Trenching, Backfilling 7 Compaction	9
02950	Site Restoration.....	4
03310	Concrete Work	15

SECTION 02200 EARTHWORK

PART 1 – GENERAL

RELATED DOCUMENTS:

Drawings and general provisions of Contract, including General and Supplementary Conditions apply to work of this section.

DESCRIPTION OF WORK:

Extent of earthwork is indicated on drawings. This work consists of grading in order to achieve finished elevations shown on the construction plans.

Preparation of subgrade for building slabs, walks, and pavements is included as part of this work.

All graded surfaces shall be smooth and uniform, without abrupt changes in slope or grade. Areas to be covered with paving shall be fine graded to the required elevations and slopes. Finished surfaces in all other areas may vary up to 0.1 feet from the required elevations.

Excavation for Mechanical/Electrical Work: Excavation and backfill required in conjunction with underground mechanical and electrical utilities, and buried mechanical and electrical appurtenances is included as work of this section.

Definition: "Excavation: consists of removal of material encountered to subgrade elevations indicated and subsequent disposal of materials removed.

QUALITY ASSURANCE:

Codes and Standards: Perform excavation work in compliance with applicable requirements of governing authorities having jurisdiction. All material and construction methods shall be in accordance with Section 120 of the Standard Specifications for Roads and Bridges, State of Florida, Department of Transportation, latest edition.

Testing and Inspection Service: Employ, at Contractor's expense, testing laboratory to perform soil testing and inspection service for quality control testing during earthwork operations.

SUBMITTALS:

Test Reports-Excavating: Submit following reports directly to Engineer from the testing services, with copy to the Contractor.

Test reports on borrow material.

Verification of each footing subgrade.

Field density test reports.

One optimum moisture-maximum density curve for each type of soil encountered.

Report of actual unconfined compressive strength and/or results of bearing tests of each strata tested.

PART 2 - PRODUCTS

Soils used as fill shall be clean sands, less than 5 percent passing the number 200 sieve.

CUT:

Where required, the site shall be excavated to the grades course. Excavated material that is suitable shall be used in the fill sections of the site. No suitable material shall be removed from the site. Any excess suitable material shall be placed at the direction of the Engineer.

FILL:

In order to insure proper bond and prevent slipping between the original ground and fill, the surface of the original ground shall be scarified to a depth of at least three inches. Each layer of fill material shall be compacted until the required density is achieved.

PART 3 - EXECUTION

GENERAL:

The site shall be rolled with a minimum of six overlapping passes of a 4 ton vibratory roller. The existing soil across the site should be compacted. The site can be filled by placing and compacting 1' - 2' lifts with the vibratory roller. Successful compaction of each lift should be attained prior to placement of successive lifts.

COMPACTION OF SUBGRADE AND FILL:

Compaction requirements shall be as shown on the plans, with a soil at or near optimum moisture content. All subgrade fill material and the top 12 inches in cut areas shall be compacted. All roots and other materials that would diminish the efficiency of the compaction operation shall be removed prior to compacting. Field tests shall be made by a soils testing laboratory under the direction of the Engineer.

TRENCH EXCAVATION:

The Contractor shall perform all excavation of every description and whatever substances encountered, to the dimensions and depths shown on the drawings, or as directed. All excavated materials not required for fill or backfill shall be removed or wasted as directed. All excavations shall be made by open cut unless otherwise shown on the plans.

Trenches shall be kept as nearly vertical as possible, and if required, shall be properly sheeted and braced. Where in the opinion of the Engineer, damage is liable to result from withdrawing sheeting, the sheeting shall be left in place.

Pipe trenches shall be excavated to a depth that will insure a minimum of thirty inches of cover unless otherwise shown on the drawings or directed. Trenches shall be excavated to provide a clearance on each side of the pipe of not less than six inches shall be excavated accurately to grade and shall provide uniform support for pipes along their entire length. Excavation shall be made for bells of all pipes.

Except in rocks, water bearing earth, or where a granular or concrete base is to be used, mechanical excavation of trenches shall be stopped above the final invert grade elevation so that the pipe may be laid on a firm undisturbed native earth bed. If over digging occurs, all loosened earth must be removed and the trench bottom brought back to grade with granular material well compacted to the satisfaction of the Engineer.

If the trench width at the top of the pipe becomes greater than a distance of three times the outside diameter of the pipe, for any reason other than by order of the Engineer, the Contractor shall install at his own expense such concrete cradling, pipe easement or other bedding as may be required by the Engineer to support the load of backfill.

If there is not a good natural foundation it will be the Contractor's responsibility to stop construction and notify the Engineer of the condition encountered. The Engineer will then instruct the Contractor as to the method to be used to correct the conditions, and the Contractor will receive extra compensation amount negotiated with the Owner.

OTHER EXCAVATIONS:

Excavation for manholes, catch basins, and other accessories shall be sufficient to leave at least 12 inches in the clear between their outer surfaces and the embankment of timber that may be used to protect them. Backfill of earth around manholes shall be filled with thoroughly compacted sand or gravel at the expense of the Contractor.

Excavation for structures shall be made to the dimensions and elevation indicated on the drawings. Where the excavation is made below the indicated elevations, the excavation shall be restored to the proper elevation with concrete fill, or the heights of the walls and footings shall be increased. Such fill or increased height of walls and footings shall be furnished by the Contractor without extra compensations, except where additional excavation is ordered to obtain proper bearing in which case the contract price will be adjusted to cover such additional work.

SHORING AND DRAINAGE:

The Contractor shall do all shoring required to perform and protect the excavation and as necessary for the safety of the employees.

The Contractor shall prevent the accumulation of water in the excavated areas, and shall remove by pumping or other means any water which accumulates in the excavation. The Contractor shall prevent the accumulation of water in both structural and trench excavations and shall remove by well point system or by other means water which accumulates in the excavation. The Contractor shall provide, install and operate a suitable and satisfactory dewatering system. The Contractor shall include the cost of this pumping equipment and work in the price bid for the work.

BACKFILLING:

Trenches shall be backfilled with excavated materials, free from large clods or stones. Backfill shall be deposited in layers not to exceed 6 inches (6") in thickness, moistened, and compacted.

Selected materials shall be used for all backfill. Trash shall not be allowed to accumulate in spaces to be backfilled, and this space shall be well cleared before backfill is placed.

No fill material shall be placed, spread or rolled while the ground or fill is frozen or thawing or during unfavorable weather conditions. When the work is interrupted by heavy rain, fill operations shall not be resumed until the moisture content and density of the fill are as previously specified.

GRADING:

General: Uniformly grade areas within limits of grading under this section, including adjacent transition areas. Smooth finish surface within specified tolerances, compact with uniform levels or slopes between points where elevations are indicated, or between such points and existing grades.

Grading Outside Building Lines: Grade areas adjacent to building lines to drain away from structures and to prevent ponding.

Finish surfaces free from irregular surface changes, and as follows:

- Lawn or Unpaved Areas: Finish areas to receive topsoil to within not more than 0.10' above or below required subgrade elevations.
- Walks: Shape surface of areas under pavement to line, grade and cross-section, with finish surface not more than 1/2" above or below required subgrade elevation.
- Compaction: After grading, compact subgrade surfaces to the depth and indicated percentage of maximum or relative density for each area classification.

PAVEMENT BASE COURSE:

General: Base course consists of placing base material, in layers of specified thickness, over subgrade surface to support a pavement course.

Grade Control: During construction, maintain lines and grades including crown and cross-slope of base course.

Shoulders: Place shoulders along edges of base course to prevent lateral movement. Construct shoulders of acceptable soil materials, placed in such quantity to compact to thickness of each base course layer. Compact and roll at least 12" width of shoulder simultaneously with compacting and rolling of each layer of base course.

Placing: Place base course material on prepared subgrade in layers of uniform thickness, conforming to indicated cross-section and thickness. Maintain optimum moisture content for compacting base material during placement operations.

When a compacted base course is shown to be 6" thick or less, place material in a single layer. When shown to be more than 6" thick, place material in equal layers, except no single layer more than 6" or less than 3" in thickness when compacted.

FIELD QUALITY CONTROL:

Quality Control Testing During Construction: Allow testing service to inspect and test and engineer to approve subgrades and fill layers before further construction work is performed.

Perform field density tests in accordance with ASTM D 1556 (sand cone method) or ASTM D 2167 (rubber balloon method) or ASTM D 2922 (nuclear method), as applicable.

If in opinion of the Engineer, based on testing service reports and inspection, subgrade or fills which have been placed are below specified density, provide additional compaction and testing at no additional expense.

MAINTENANCE:

Protection of Graded Areas: Protect newly graded areas from traffic and erosion. Keep free of trash and debris.

Repair and re-establish grades in settled, eroded, and rutted areas to specified tolerances.

Reconditioning Compacted Areas: Where completed compacted areas are disturbed by subsequent construction operations or adverse weather, scarify surface, re-shape, and compact to required density prior to further construction.

Settling: Where settling is measurable or observable at excavated areas during general project warranty period, remove surface (pavement, lawn or other finish), add backfill material, compact, and replace surface treatment. Restore appearance, quality, and condition of surface or finish to match adjacent work, and eliminate evidence of restoration to greatest extent possible.

EXISTING UTILITY LINES:

Attention is called to the fact that the Contractor is responsible for contacting all utility companies to obtain locations of all existing utilities or obstructions which he may encounter during construction. After location of utilities by the appropriate utility company, it is the Contractor's liability to protect all such utility lines, including service lines and appurtenances, and to replace at his own expense any which may be damaged by the Contractor's equipment or forces during construction of the project.

BARRICADES, GUARDS, AND SAFETY PROVISIONS:

To protect persons from injury and to avoid property damage, adequate barricades, construction signs, torches, red lanterns and guards as required shall be placed and maintained

during the progress of the construction work. Rules and regulations of the local authorities with respect to safety provisions shall be observed.

TRAFFIC CONTROLS:

Excavations for pipe laying operation shall be conducted in a manner to cause the least interruption to traffic. When traffic must cross open trenches, the Contractor shall provide suitable bridges.

FLOW DRAIN AND SEWER MAINTENANCE:

Adequate provision shall be made for the flow of sewers, drains, and water courses encountered during construction, and the structures which may have been disturbed shall be satisfactorily restored by the Contractor.

PROPERTY PROTECTION:

Trees, fences, poles, and all other property shall be protected unless their removal is authorized; and any property damaged shall be satisfactorily restored by the Contractor at the Contractor's expense.

CLEAN-UP:

Before final inspection and acceptance the Contractor shall clean ditches, shape shoulders and restore all disturbed areas, including street crossings, grass plots, regrassing if necessary, to as good a condition as existed before work started. All trenches shall be leveled, and loose material removed from pavement, gutters, and sidewalks, employing hand labor if necessary.

EROSION CONTROL:

The Contractor shall be responsible for the prevention of erosion from the site and for maintaining graded surfaces for the duration of the project.

The Contractor shall take whatever steps necessary to prevent erosion and will be responsible for any damages, which might occur to down-land properties as a result of increased runoff from the site during sitework construction.

END SECTION 02200

**SECTION 02211
SODDING**

PART 1 - GENERAL

1.01 WORK INCLUDED

- A. Sod Installation

1.02 REFERENCES

- A. ASPA - American Sod Producers Association - Guideline Specifications to Sodding.
- B. FS O-F-241 - Fertilizers, Mixed, Commercial.

1.03 DEFINITIONS

- A. Weeds: Dandelion, Jimsonweed, Quackgrass, Horsetail, Morning Glory, Rush Grass, Mustard, Lambsquarter, Chickweed, Cress, Crabgrass, Canadian Thistle, Nutgrass, Poison Oak, Blackberry, Tansy Ragwort, Bermuda Grass, Johnson Grass, Poison Ivy, Nut Sedge, Nimble Hill, Bindweed, Bent Grass, Wild Garlic, Perennial Sorrel, and Brome Grass.

1.04 DELIVERY, STORAGE, AND HANDLING

- A. Deliver sod on pallets. Protect exposed roots from dehydration.
- B. Do not deliver more sod that can be laid within 24 hours.

PART 2 - PRODUCTS

2.01 ACCEPTABLE SOD GROWERS

- A. Nurseries and Sod Growers in the surrounding area who have a five year record are acceptable.

2.02 MATERIALS

- A. Sod:
 - 1. ASPA approved, field grown grade; cultivated grass sod; for low maintenance and traffic durability, with strong fibrous root system, free of stone, burned or bare spots; containing no more than 5 weeds per 1000 square feet.
- B. Approved Sod:
 - 1. Tiff Tuff, Bermuda (Cynodon Dactylon) as supplied by McCall Sod Farm or approved equal.

2.03 HARVESTING SOD

- A. Machine cut sod and load on pallets in accordance with ASPA guidelines.

- B. Cut sod in area not exceeding one square yard, with minimum 1/2 inch and maximum one inch topsoil base.

PART 3 - EXECUTION

3.01 INSPECTION

- A. Verify that prepared soil base is ready to receive the work of this Section.
- B. Beginning of installation means acceptance of existing site conditions.

3.02 PREPARATION OF SUBSOIL

- A. Prepare subsoil to eliminate uneven areas and low spots. Maintain lines, levels, profiles and contours. Make changes in grade gradual. Blend slopes into level areas.
- B. Remove foreign materials and undesirable plants and their roots. Do not bury foreign material beneath areas to be sodded. Remove contaminated subsoil.

3.03 LAYING SOD

- A. Moisten prepared surface immediately prior to laying sod.
- B. Lay sod immediately on delivery to site and within 24 hours after harvesting to prevent deterioration.
- C. Lay sod tight with no open joints visible, and no overlapping; stagger end joints 12-inches overlapping; minimum. Do not stretch or overlap sod pieces.
- D. Lay smooth. Align with adjoining grass areas. Place top elevation of sod 1/2 inch below adjoining paving or curbs.
- E. On slopes 6 inches per foot and steeper, lay sod perpendicular to slope and secure every row with wooden pegs at maximum 2 feet on center. Drive pegs flush with soil portion of sod.
- F. Prior to placing sod, on slopes exceeding 8 inches per foot or where indicated, place wire mesh over topsoil. Securely anchor in place with wood pegs sunk firmly into the ground.
- G. Water sodded areas immediately after installation. Saturate sod to 4 inches of soil.
- H. After sod and soil have dried, roll sodded areas to ensure good bond between sod and soil and to remove minor depressions and irregularities.
- I. Sod shall be laid in all ditch areas and slopes that are equal to or steeper than 1 vertical to 3 horizontal or in areas determined by the Engineer to “erosion problem” areas. Sod shall be pinned down for stabilization in these areas.

END OF SECTION 02211

SECTION 02222
TRENCHING, BACKFILLING AND COMPACTING

PART 1 - GENERAL

1.01 DESCRIPTION OF WORK

- A. The extent of trenching, backfilling and compacting is shown on the drawings.
- B. This section includes furnishing equipment, labor and materials, and performing all operations necessary and incidental to perform the required work.

PART 2 – PRODUCTS NOT USED

PART 3 - EXECUTION

3.01 CLEARING THE SITE

- A. The site of the work shall be cleared of all trees, shrubs, paving and objectionable material which interfere with the prosecution of the proposed work.
- B. Trees and shrubs which will not interfere with construction shall be protected from damage.
- C. Clearing shall be considered as an incidental item of excavation.

3.02 EXCAVATION

- A. General:
 - 1. Perform excavation described of whatever substance encountered to the dimensions and depths specified or shown on the drawings.
 - 2. Undercutting will not be permitted, except when ordered by the ENGINEER. Material suitable for backfill shall be stockpiled near the site.
 - 3. Rock or other material undesirable for backfill shall be spoiled outside the area in a neat manner, as directed by the ENGINEER.
 - 4. Where it is necessary to cut roots projecting into an excavation or where it is necessary to trim branches for equipment clearance, all severed root ends or cuts to branches over 1/2-inch diameter shall be treated with an asphalt base pruning paint.
 - 5. Backfill over exposed roots as soon as possible.

B. Rock:

1. Where encountered in the trench bed, rock shall be excavated to a depth of 1/4 of the pipe diameter below the bottom of the pipe but in no case less than 4 inches.
2. All undercut trench excavation shall be backfilled and tamped with materials as specified in the following paragraphs under Unstable Subgrade.

C. Unstable Subgrade:

1. In the event that unsuitable material is encountered at or below the excavation depth specified or shown on the drawings, the ENGINEER shall be notified.
2. Such material shall be removed and replaced with suitable material. Methods and materials used for replacement shall be one of the following as directed by the ENGINEER in writing.
 - a. Suitable earth or sand compacted in the trench. Materials shall be furnished as a part of the Bid Proposal item covering excavation and backfill.
 - b. Gravel or crushed limerock, compacted in the trench and paid for under the appropriate item.
 - c. Existing materials, stabilized after removal and then replaced and compacted in the trench at no additional cost to the OWNER.
3. The Engineer shall determine the methods and materials to be used, based upon the condition of the excavation, the pipe structure to be supported, and the availability and character of stabilizing materials.

D. Trenches:

1. Keep pipe laying operation as close to the excavation operation as possible during the prosecution of the work. The ENGINEER reserves the right to stop the excavation at any time when, in his opinion, the excavation is opened too far in advance of the pipe laying.
 - a. Pipe trenches shall be excavated to a depth that will insure a minimum of 36 inches of cover for ductile iron and PVC pipe and 54 inches of cover for polyethylene pipe, except service laterals. Trenches shall be only of sufficient width to provide a free working space on each side of the pipe.
 - b. To prevent excess pressure on the pipe, the maximum width of trench at the top of the pipe and at the bottom of the trench shall not be greater than 2 feet more than the greatest exterior diameter of the pipe.

- c. If this maximum width is exceeded, it shall be the CONTRACTOR's responsibility to provide, at no additional cost to the OWNER, such additional bedding or select backfill materials as the ENGINEER may require.
 - d. The excavation below the spring line shall be made to conform as near as possible to the shape of the lower third of the pipe.
 - e. To protect the pipe lines from unusual stresses, all work shall be done in open trenches.
 - f. Excavation shall be made for bells of all pipes and of sufficient depth to permit access to the joint for construction and inspections. In no case will the bells be used to support the body of the pipe.
 - 2. In order to avoid existing utilities, at times it may be necessary for the pipe to be laid deeper than the minimum cover specified in the preceding paragraph. At such time the CONTRACTOR will not be allowed extra compensation for additional excavation involved.
 - 3. In case excavation has been made deeper than necessary, a layer of concrete, fine gravel or other material satisfactory to the ENGINEER shall be placed, at no extra cost, to secure a firm foundation for the lower third of each pipe.
 - a. Where possible, excavated material shall be placed so as not to interfere with public travel.
 - b. Bridging shall be provided to afford necessary access to public or private premises.
- E. Bridging shall be considered as part of the excavation operation and shall be supplied at no additional cost to the OWNER. Structural: (For inlets, manholes, valve pits and similar structures)
 - 1. Structural Excavation:
 - a. Sufficient material shall be removed to allow proper space for erecting and removing forms. The elevations of the bottoms of footings, if shown on the drawings, shall be considered as approximate only, and the ENGINEER may order, in writing, such changes in dimensions or elevations of footings as may be deemed necessary to secure a satisfactory foundation.
 - b. Excavation for structures shall be sufficient to leave at least 12 inches in the clear between their outer surfaces and the embankment of timber that may be used to protect them.
 - c. Backfill of earth under structures will not be permitted.

- d. Excess excavation for structures shall be filled with thoroughly compacted sand, gravel, or concrete at the expense of the CONTRACTOR.
 2. After excavation for a structure is completed, the CONTRACTOR shall notify the ENGINEER to that effect. No concrete or reinforcing steel shall be placed until the ENGINEER has approved the depth of the excavation and the character of the foundation material.
- F. Sheeting and Shoring:
1. The CONTRACTOR shall provide all trench and structural bracing, sheeting or shoring necessary to construct and protect the excavation, existing utilities, structures and private property of all types and as required for the safety of the employees.
 2. Sheeting shall be removed or cut off by the CONTRACTOR during backfilling operations as directed by the ENGINEER.
 3. Sheeting which is left in place by order of the ENGINEER will be paid for under the item, Lumber left in Place.
 4. Removal of shoring for structures shall be done in such a manner as not to disturb or mar finished masonry or concrete surfaces.

3.03 DRAINAGE

- A. Grading shall be controlled in the vicinity of excavations so that the surface of the ground will be properly sloped to prevent water from running into trenches or other excavated areas.
- B. Any water which accumulates in the excavations shall be promptly removed by well point or by other means satisfactory to the ENGINEER in such a manner as to not create a nuisance to adjacent property or public thoroughfare.
- C. Trenches shall be kept dry while pipe is being laid.
- D. Bridging of dewatering pipe shall be provided where necessary.
- E. Pumps and engines for well point systems shall be operated with mufflers, and at a minimum noise level suitable to a residential area.
- F. The CONTRACTOR will not be allowed to discharge water into the OWNER's storm drainage system without the written approval of the ENGINEER. Approval will be subject to the condition that the storm sewer be returned to its original condition.
- G. The CONTRACTOR is responsible for carrying the water to the nearest ditch or body of water and for obtaining the necessary permission to use same. The CONTRACTOR shall be financially responsible for any nuisance created due to carrying off water from his drainage system.

3.04 BACKFILL

A. Trenches:

1. Trenches shall be backfilled immediately after the pipe is laid unless other protection for the pipeline is provided.
2. Clean earth, sand, crushed limerock or other material approved by the ENGINEER shall be used for backfill.
3. Backfill material shall be selected, deposited and compacted (simultaneously on both sides of the pipe) so as to eliminate the possibility of lateral displacement of the pipe.
4. Backfill material shall solidly tamped around the pipes in layers to a level at least 1 foot above the top of the pipe. Each layer shall be compacted to a maximum thickness of 6 inches.
5. Unpaved Areas:
 - a. In unpaved areas, the remainder of the backfill shall be deposited and then compacted by puddling, water flooding, or mechanical tampers.
 - b. Mechanical tamping of layers in unpaved areas shall be to a maximum thickness of 12 inches.
6. Areas to be Paved:
 - a. In areas to be paved or repaved, the entire depth of backfill shall be deposited in layers and compacted by hand or mechanical tampers to a maximum thickness of 6 inches.
 - b. Compaction shall be carried out to achieve a density of at least 98% of the maximum density as determined by AASHTO, Method T-180.
7. Density Tests In Areas to be Paved:
 - a. In areas to be paved, density tests for determination of the specified compaction shall be made by a testing laboratory and spaced one in every 300 feet of trench cut.
 - b. It is the intent of this specification to secure a condition where no further settlement of trenches will occur.
8. Roadway Base for areas to be Paved:
 - a. When backfilling is completed, the roadway base for pavement replacement may be placed immediately.

B. It will be the responsibility of the CONTRACTOR to restore the surface to the original grade wherever settlement occurs. Wet Trenches (CONTRACTOR's Option):

1. Backfill for the pipe bed in wet trenches shall be crushed, graded limerock, and compacted in the trench.
2. After the pipe is laid, a graded limerock backfill shall be placed and worked in around the haunches to a point 6 inches above the pipe. The width of the limerock material around the pipe shall not be less than the outside diameter of the pipe plus 6 inches on each side of the pipe. Material shall be carefully distributed along the pipe so as to provide full and uniform support under and around the pipe.
3. Six inches above the top of the pipe and up to the water level, material from the excavations with no rock or earth exceeding 4 inches in any one dimension shall then be lifted to the trench and released at the water level. Material shall be uniformly distributed for the full width of the trench.
4. Backfill and compaction above the water level in the trench shall be as specified above.
5. All costs for graded limerock placed in wet trenches shall be included in the cost of stage excavation and backfill for the various sizes of pipe.

C. Bedding and Backfill - Flexible Pipe:

1. For polyvinyl chloride (PVC) pipe, the bedding and backfill materials shall be such as to limit the vertical ring deflection to 5% of the inside pipe diameter. A deflection greater than 5% of the inside diameter shall be cause for rejection of the pipe.
2. Class IV or Class V materials as defined in ASTM D2321-74 shall not be used for bedding, haunching or initial backfill for flexible pipes.
3. For PVC plastic pipe, bedding shall be in accordance with ASTM D2321-74, using Class I, II or III materials, except under wet conditions. In any area where the pipe will be installed below existing or future groundwater levels or where the trench could be subject to inundation, Class I material shall be placed to the springline of the pipe.
4. A minimum of effort is needed to compact the material. However, in the initial stage of placing this type of material, take care to ensure that sufficient material has been worked under the haunch of the pipe to provide adequate side support. Take precautions to prevent movement of the pipe during placing of the material under the pipe haunch.

Except for the protection of the pipe from large particles of backfill material, little care need be taken and no compaction is necessary in placing backfill material in the balance of the initial backfill area above the pipe. Where unstable trench wall exist because of migratory materials, such as

water-bearing silts or fine sand, take care to prevent the loss of side support through the migratory action.

5. All bedding requirements for flexible pipe specified in the preceding paragraphs shall be included in the price bid for the applicable pipe material and no additional compensation for bedding material will be allowed.

D. Structural:

1. After completion of foundation footings and walls and other construction below the elevation of the final grades, and prior to backfilling, forms shall be removed and the excavation shall be cleared of all trash and debris.
2. Material for backfilling shall consist of the excavation, borrow sand or other approved materials, and shall be free of trash, lumber or other debris.
3. Backfill shall be placed in horizontal layers not in excess of 9 inches in thickness, and have a moisture content such that a density may be obtained to prevent excessive settlement or shrinkage.
4. Each layer shall be compacted by hand or approved machine tampers with extreme care being exerted not to damage pipe or structures.
5. Backfill shall be placed and compacted evenly against the exposed surfaces to prevent undue stress on any surface.

3.05 RESTORATION OF SURFACE IMPROVEMENTS

- A. Roadways, including shoulders, alleys and driveways of shell, limerock, stabilized soil or gravel, grass plots, sod, shrubbery, ornamental trees, signs, fences, or other surface improvements on public or private property which have been damaged or removed in excavation, shall be restored to conditions equal to or better than conditions existing prior to beginning work.
- B. Restoration of shoulders shall consist of seeding and mulching or stabilizing with limerock as selected by the ENGINEER.
- C. The cost of doing this work shall be included in the cost of the various applicable items.
- D. General Quality Control will be used as an aid in determining conditions prior to construction.
- E. Materials for unpaved roadways, road shoulders, alleys, or driveways, shall be compacted as described in the plans. The cost of this work and furnishing new materials shall be included in the cost of the applicable items of work as no separate payment will be made, unless a separate bid item is provided.

3.06 FINE GRADING

- A. Finished areas around structures shall be graded smooth and hand raked and shall meet the elevations and contours shown on the drawings. Lumber, earth clods, rocks and other undesirable materials shall be removed from the site.

3.07 DISPOSAL OF MATERIALS

- A. Such portions of the excavated materials as needed and as suitable, shall be used for backfilling and grading about the completed work to the elevations as shown of the drawings or as directed. Excavated material in excess of the quantity required for this purpose shall be disposed of by the CONTRACTOR in those areas designated by the OWNER and as shown on the drawings. The CONTRACTOR shall leave the earth over the trenches or other excavations in a neat and uniform condition acceptable to the OWNER.

3.08 PAVEMENT REPLACEMENT

- A. Asphalt pavement shall be removed by saw cutting on a straight line with edges as vertical as possible. Concrete pavement or asphalt surfaced concrete shall be removed by cutting with a concrete saw in as straight a line and vertically as possible. Materials to replace State Highway paving shall conform to the specifications required by the Florida Department of Transportation Specifications for Type S-I asphaltic concrete surface course, or as specifically shown in the plans.
- B. Prior to replacing concrete or asphalt pavement replacement, a limerock base shall be laid. The base for concrete pavement shall be 6 inches of compacted thickness, and that for asphalt pavement shall be 8 inches of compacted thickness. The base course for each shall be compacted to a minimum of 98% of the maximum density as determined by AASHTO, Method T-180. The OWNER will have tests made by an independent testing laboratory to verify compaction results. One test will be made for each block of continuous trench cut.
- C. Non-asphalt pavement replacement shall be replaced of like material and thickness. Asphalt or built-up asphalt pavement shall be replaced with like material or concrete as directed by the ENGINEER.
- D. Where asphalt or built-up asphalt pavement is replaced by concrete, the concrete shall have a minimum of 6 inches in thickness and be reinforced with 6 by 6 no. 6 gage welded wire fabric. Concrete for paving shall be 3,000 psi design strength. Where the pavement replacement is of like material, it shall be replaced in thickness equal to or better than that existing at the time of removal.
- E. Unless the base is sealed or other temporary paving applied over areas to be repaved, pavement shall be replaced not later than 3 weeks after completion of backfill.

3.09 TESTS

- A. The CONTRACTOR shall furnish facilities for making all density tests and make such restorations as may be necessary due to test operations. All density tests on backfill or base replacement will be made by a commercial testing laboratory employed by the CONTRACTOR and at such locations as may be recommended by the ENGINEER. If the densities as determined by the specified tests fall below the required minimums, the CONTRACTOR shall pay for all retests.

3.10 SIDEWALK, CURB AND GUTTER REMOVAL AND REPLACEMENT

- A. Sidewalk, curb and gutter removal and replacement required in the construction of this work shall be done by the CONTRACTOR.
- B. Reasonable care shall be exercised in removing sidewalk and curb and gutter, and the CONTRACTOR shall either stockpile or dispose of this material as directed by the ENGINEER.
- C. Brick, concrete or built-up asphalt sidewalk replacement and curb and gutter replacement shall be replaced of like material in a manner and condition equal to or better than that existing at the time of removal.
- D. Materials and methods of replacing State Highway sidewalks or curbs shall conform to the Florida Department of Transportation specifications.

END OF SECTION 02222

**SECTION 02950
SITE RESTORATION**

PART 1 - GENERAL

1.01 DESCRIPTION OF WORK

- A. The work includes the restoration of driveways, lawn areas, trees and plants, roadways, sprinkler systems, walks and any other existing improvement affected by the proposed work.
- B. This section includes furnishing equipment, labor and materials, and performing all necessary and incidental operations to perform the required work.

PART 2 – PRODUCTS

2.01 SOD

- A. Any slope equal to or steeper than 1 vertical to 3 horizontal shall be sodded and the sod shall be pinned down for stabilization.
- B. The CONTRACTOR shall, at his expense, maintain the sodded areas in a satisfactory condition until final acceptance of the project. Such maintenance shall include watering, re-staking sod, filling, leveling and repairing of any washed or eroded areas, as may be necessary.

2.02 PLANTS AND TREES

- A. Existing damaged plants and trees shall be replaced by plants and trees of equal type, quality and size whenever possible. All new plants and trees shall be sound, healthy, vigorous and free from defects, decay, disfiguring, bark abrasions, plant diseases, insect pests, their eggs or larvae. The new plants shall be approved by the ENGINEER before placing.
- B. Existing plants may be removed, preserved, and replaced at the CONTRACTOR's option. Plants shall be handled by an approved nursery.
- C. Plants shall be watered and cared for until new growth appears. Dead and dying plants shall be immediately replaced. Plants used shall be in accordance with the standards for Florida No. 1 or better as given in Grades and Standards for Nursery Plants Part 1.
- D. Plants shall conform to the sizes indicated by the OWNER.
- E. Trees shall be guaranteed for one year. If the replaced tree dies within one year of project completion it shall be replaced by the CONTRACTOR at no expense to the Government.

2.03 MULCH

- A. Match existing mulch.

2.04 WATER

- A. The water used in the performance of this Contract shall be of drinking water quality, clean and free from injurious amounts of oil, acid, alkali, or organic matter.

2.05 PLANTING MIXTURE:

- A. The 18-inch planting mixture, when required, shall consist of a thorough mixture of 40% peat and 60% sand. The peat shall be Florihome peat or equivalent and the sand shall be clean and free from debris of any kind.

2.06 FERTILIZER

- A. Fertilizer shall be pelletized 13-13-13, or approved equal.

PART 3 - EXECUTION

3.01 LANDSCAPING RESTORATION

A. Lawn Areas:

- 1. Any lawn area affected by the required work shall be restored to a condition equal or better than the conditions existing before the commencement of work.

B. Balled Plants:

- 1. Plants where required shall be adequately balled with firm natural balls of soil, sized as set forth in "Horticultural Standards."
- 2. Balls shall be firmly wrapped with burlap or equally approved strong cloth.

C. No balled plant will be planted if the ball is cracked or broken before or during the process of planting.

D. Preparation of Plant Pits:

- 1. All plant pits shall be circular in outline and have vertical sides.
- 2. Tree pits shall be two feet wider than the width of the ball and 1 foot deeper than the depth of the ball.
- 3. Shrubs that are either B&B or 3 gallons + shall have pits 2 feet wider than the width of the plant ball and 6 inches deeper than the depth of the ball.
- 4. Smaller shrubs shall have pits that are at least one foot wider than the width of the plant ball and 6 inches deeper than the ball depth.

E. Setting Plants:

- 1. All plants except as otherwise specified, shall be centered in pits.

2. Deep planting shall be avoided and unless otherwise specified, plants shall be set at such a level that after settlement they will bear the same relation to the required grade as they have to the natural grade before being transplanted.
- F. Balled and Burlapped:
1. Balled and burlapped plants and palm trees shall be placed on 6 inches to 12 inches of tamped planting mixture and adjusted so as to be at the proper level.
 2. The rope and burlap shall be cut away and the burlap folded down to the bottom of the pit.
 3. Very large B&B plants shall remain wrapped until fully backfilled and then just the upper portion of the burlap shall be removed.
 4. Backfill of planting mix shall be placed halfway up the pit and then water tamped.
 5. After this water has drained away, backfill around the ball to grade and water tamp again.
 6. Finally, form a ridge of soil around the edge of the pit to form a saucer and full area three times with water.
- G. Water: Water to be used initially during plant installation shall be furnished by the CONTRACTOR. The existing irrigation system, where damaged, shall be promptly repaired after the installation of the plants.
- H. Options as to Methods:
1. Any plant may be furnished container grown instead of balled if all other requirements are met.
- I. Immediately before sod is placed, 8-8-8 fertilizer shall be applied at the rate of approximately 500 pounds per acre, by broadcasting and raking into the planting area.
- J. Sod shall be firmly embedded by light tamping. Wherever necessary to prevent an erosion condition caused by vertical edges at the outer limits of the sodded area, the sod shall be tamped so as to produce a featheredge at the outer limits. The sod shall be kept in a moist condition after it is planted. Water shall not be applied between the hours of 8 a.m., and 4 p.m. or when there is danger of freezing.
- K. The CONTRACTOR shall, at his expense, maintain the planted areas in a satisfactory condition until final acceptance of the project. Such maintenance shall include watering, filling, leveling and repairing of any washed or eroded areas, as may be necessary.

3.02 PAVEMENT REPLACEMENT

- A. Asphalt pavement shall be removed by saw cutting on a straight line with edges as vertical as possible. Concrete pavement or asphalt surfaced concrete shall be removed by cutting with a concrete saw in as straight a line and vertically as possible.
- B. Non-asphalt pavement replacement shall be replaced of like material and thickness. Asphalt or built-up asphalt pavement replacement shall be replaced with like material or concrete as directed by the ENGINEER.
 - 1. Where asphalt or built-up asphalt pavement is replaced by concrete, the concrete shall have a minimum of 6 inches in thickness and be reinforced with 6 by 6 No. 6 gage welded wire fabric.
 - 2. Where the pavement replacement is of like material, it shall be replaced in thickness equal to or better than that existing at the time of removal.
- C. Road cuts across City, County, or State roads shall not be cut.

3.03 Unless the base is sealed or other temporary paving applied over driveway areas to be repaved, pavement shall be replaced not later than three weeks after completion of backfill.

3.04 CURB REMOVAL AND REPLACEMENT

- A. Curb removal and replacement required in the construction of this work shall be done by the CONTRACTOR.
- B. Reasonable care shall be exercised in removing the curb, and the CONTRACTOR shall either stockpile or dispose of this material as directed by the ENGINEER.
- C. Curb shall be replaced of like material in a manner and condition equal to or better than that existing at the time of removal.
- D. Materials and methods of replacing State Highway sidewalks or curbs shall conform to the Department of Transportation specifications.

3.05 TESTS

- A. The CONTRACTOR shall furnish facilities for making all density tests and make such restorations as may be necessary due to test operations.
- B. All density tests on backfill or base replacement will be made by a commercial testing laboratory employed by the CONTRACTOR at such locations as may be recommended by the ENGINEER.
- C. If the densities as determined by the specified tests fall below the required minimums, the CONTRACTOR shall pay for all retests.

END OF SECTION 02950

SECTION 03310 CONCRETE WORK

PART 1 - GENERAL

RELATED DOCUMENTS:

Drawings and general provisions of Contract, including General and Supplementary Conditions, apply to work of this section.

DESCRIPTION OF WORK:

Extent of concrete work is shown on Drawings.

Concrete paving and walks are specified in Division 2.

Mechanical finishes and concrete floor toppings are specified in other Division 3 sections.

SUBMITTALS:

Product Data: Submit data proprietary materials and items, including reinforcement and forming accessories, admixtures, patching compounds, waterstops, joint systems, curing compounds, dry-shake finish materials, and others as requested by Engineer.

Shop Drawings, Reinforcement: Submit original shop drawings for fabrication, bending, and placement of concrete reinforcement. Comply with ACI 315 "Manual of Standard Practice for Detailing Reinforced Concrete Structures" showing bar schedules, stirrup spacing, diagrams of bent bars, and arrangement of concrete reinforcement. Include special reinforcement required for openings through concrete structures.

Engineer's review is for general engineering applications and features only. Design of formwork for structural stability and efficiency is Contractor's responsibility.

Laboratory Test Reports: Submit laboratory test reports for concrete materials and mix design test.

QUALITY ASSURANCE:

Codes and Standards: Comply with provisions of following codes, specifications, and standards, except where more stringent requirements are shown or specified:

- ACI 301 "Specifications for Structural Concrete for Buildings".
- ACI 318 "Building Code Requirements for Reinforced Concrete".
- Concrete Reinforcing Steel Institute (CRSI) "Manual of Standard Practice".

Concrete Testing Services: Engage a testing laboratory acceptable to Engineer to perform material evaluation tests and to design concrete mixes.

Materials and installed work may require testing and retesting at anytime during progress of work.

Tests, including retesting of rejected materials for installed work, shall be done at Contractor's expense.

PROJECT CONDITIONS:

Protection of Footings against Freezing: Cover completed work at footing level with sufficient temporary or permanent cover as required to protect footings and adjacent subgrade against possibility of freezing; maintain cover for time period as necessary.

Protect adjacent finish materials against spatter during concrete placement.

PART 2 - PRODUCTS

FORM MATERIALS:

Forms for Exposed Finish Concrete: Plywood, metal, metal-framed plywood faced, or other acceptable panel-type materials, to provide continuous, straight, smooth, exposed surfaces. Furnish in largest practicable sizes to minimize number of joints.

Use plywood complying with U. S. Product Standard PS-1 "B-B (Concrete Form) Plywood", Class I, Exterior Grade or better, mill-oiled and edge-sealed, with each piece bearing legible inspection trademark.

Forms for Unexposed Finish Concrete: Plywood, lumber, metal, or other acceptable material. Provide lumber dressed on at least 2 edges and one side for tight fit.

Form Coatings: Provide commercial formulation form-coating compounds that will not bond with, stain, nor adversely affect concrete surfaces, and will not impair subsequent treatments of concrete surfaces.

Form Ties: Factory-fabricated, adjustable-length, removable or snapoff metal form ties, designed to prevent form deflection and to prevent spalling concrete upon removal. Provide units which will leave no metal closer than 1-1/2" to surface.

Provide ties which, when removed, will leave holes not larger than 1" diameter in concrete surface.

REINFORCING MATERIALS:

- Reinforcing Bars: ASTM A 615, Grade 60, deformed.
- Steel Wire: ASTM A 82, plain, cold-drawn steel.
- Welded Wire Fabric: ASTM A 185, welded steel wire fabric.
- Welded Deformed Steel Wire Fabric: ASTM A 497.

Supports for Reinforcement: Bolsters, chairs, spacers, and other devices for spacing, supporting, and fastening reinforcing bars and welded wire fabric in place. Use wire bar type supports complying with CRSI specifications.

For slabs-on-grade, use supports with sand plates or horizontal runners where base material will not support chair legs.

CONCRETE MATERIALS:

- Portland Concrete: ASTM C 150, Type I.

Use one brand of cement throughout project, unless otherwise acceptable to Engineer.

Normal Weight Aggregates: ASTM C 33, and as herein specified. Provide aggregates from a single source for exposed concrete.

For exterior exposed surfaces, do not use fine or coarse aggregates containing spalling-causing deleterious substances.

Water: Drinkable.

RELATED MATERIALS:

Polyvinyl Chloride Waterstops: Corps of Engineers CRD-C 572.

Available Manufacturers: Subject to compliance with requirements, manufacturers offering products which may be incorporated in the work include, but are not limited to, the following:

Manufacturer: Subject to compliance with requirements, provide products of one of the following or equal:

- AFCO Products
- The Burke Co.
- Edoco Technical Products
- Greenstreet Plastic Products
- Harbour Town Products
- W. R. Meadows
- Progress Unlimited
- Schleigel Corp.
- Vinylex Corp.

Granular Base: Evenly graded mixture of fine and coarse aggregates to provide, when compacted, a smooth and even surface below slabs on grade.

Vapor Retarder: Provide vapor retarder cover over prepared base material where indicated below slabs on grade. Use only materials which are resistant to decay when tested in accordance with ASTM E 154, as follows:

- Polyethylene sheet not less than 8 mils thick.
- Non-Shrink Grout: CRD-C 621, factory pre-mixed grout.

Products: Subject to compliance with requirements, provide one of the following or equal:

Metallic:

- "Vibrofoil", A. C. Horn, Inc.
- "Metallic Spec. Grout", The Burke Co.
- "Embeco 636", Master Builders
- "Ferrolith GDS", Sonneborn-Rexnord
- "Hi-Mod Grout", Euclid Chemical Co.
- "Kemox G", Sika Chemical Co.
- "Ferrogrout", L & M Const. Chemical Co.
- "Supreme Plus", Gifford-Hill/American Admixtures

Non-metallic:

- "Set Grout", Master Builders
- "SonogROUT", Sonneborn-Rexnord
- "Euco-NS", Euclid Chemical Co.
- "Supreme", Gifford-Hill/American Admixtures
- "Crystex", L & M Const. Chemical Co.
- "Sure-Grip Grout", Dayton Superior Corp.
- "Horngrout", A. C. Horn, Inc.
- "Five Star Grout", U. S. Grout Corp.

Liquid Membrane-Forming Curing Compound: Liquid type membrane-forming curing compound complying with ASTM C 309, Type I, Class A. Moisture loss not more than 0.055 gr./sq. cm. when applied at 200 sq. ft./gal.

Products: Subject to compliance with requirements, provide one of the following or equal:

- "Masterseal", Master Builders
- "A-H 3 Way Sealer", Anti-Hydro Waterproofing Co.
- "Ecocure", Euclid Chemical Co.
- "Clear Seal", A. C. Horn, Inc.
- "Sealco 309", Gifford-Hill/American Admixtures
- "J-20 Acrylic Cure", Dayton Superior
- "Spartan-Cote", The Burke Co.
- "Sealkure", Toch Div. - Carboline
- "Kure-N-Seal", Sonneborn-Rexnord
- "Polyclear", Upco Chemical/USM Corp.
- "L & M Cure", L & M Construction Chemicals
- "Klearseal", Setcon Industries
- "LR-152", Protex Industries
- "Hardtop", Gifford-Hill

PROPORTIONING AND DESIGN OF MIXES:

Prepare design mixes for each type and strength of concrete by either laboratory trial batch or field experience methods as specified in ACI 301. If trial batch method used, use an independent testing facility acceptable to Engineer for preparing and reporting proposed mix designs. The testing facility shall not be the same as used for field quality control testing.

Submit written reports to Structural Engineer of each proposed mix for each class of concrete at least 15 days prior to start of work. Do not begin concrete production until mixes have been reviewed by Engineer.

Design mixes to provide normal weight concrete with the following properties, as indicated on drawings and schedules:

- 4000 psi 28-day compressive strength; W/C ratio, 0.44 maximum (non-air-entrained).
- 3000 psi 28-day compressive strength; W/C ratio, 0.58 maximum (non-air-entrained).
- 2500 psi 28-day compressive strength; W/C ratio, 0.67 maximum (non-air-entrained).

Lightweight Concrete: Proportion mix as herein specified. Design mix to produce strength and modulus of elasticity as noted on Drawings, with a split-cylinder strength factor (Fct) of not less than 5.5 for 3000 psi concrete and a dry weight of not less than 95 lbs. or more than 110 lbs. after 28 days. Limit shrinkage to 0.03 percent at 28 days.

Adjustment to Concrete Mixes: Mix design adjustments may be requested by Contractor when characteristics of materials, job conditions, weather, test results, or other circumstances warrant; at no additional cost to Owner and as accepted by Engineer. Laboratory test data for revised mix design and strength results must be submitted to and accepted by Engineer before using in work.

Use air-entraining admixture in exterior exposed concrete, unless otherwise indicated. Add air-entraining admixture at manufacturer's prescribed rate to result in concrete at point of placement having total air content with a tolerance of plus-or-minus 1-1/2 percent within following limits:

Slump Limits: Proportion and design mixes to result in concrete slump at point of placement as follows:

- Ramps, slabs, and sloping surfaces: Not more than 3 inches.
- Reinforced foundation systems: Not less than 1 inch and not more than 3 inches.
- Concrete containing HRWR admixture (super-plasticizer): Not more than 8 inches after addition of HRWR to site-verified 2-3 inches slump concrete.
- Other concrete: Not less than 1 inch nor more than 4 inches.

CONCRETE MIXING:

Ready-Mix Concrete: Comply with requirements of ASTM C 94, and as herein specified.

During hot weather, or under conditions contributing to rapid setting of concrete, a shorter mixing time than specified in ASTM C 94 may be required.

PART 3 - EXECUTION

GENERAL:

Coordinate the installation of joint materials and vapor retarders with placement of forms and reinforcing steel.

FORMS:

Design, erect, support, brace, and maintain formwork to support vertical and lateral, static, and dynamic loads that might be applied until such loads can be supported by concrete structure. Construct formwork so concrete members and structures are of correct size, shape, alignment, elevation, and position. Maintain formwork construction tolerances complying with ACI 347.

Design formwork to be readily removable without impact, shock, or damage to cast-in-place concrete surfaces and adjacent materials.

Construct forms to sizes, shapes, lines, and dimensions shown, and to obtain accurate alignment, location, grades, level and plumb work in finished structures. Provide for openings, offsets, sinkages, keyways, recesses, moldings, rustications, reglets, chamfers, blocking, screeds, bulkheads, anchorages and inserts, and other features required to work. Use selected materials to obtain required finishes. Solidly butt joints and provide back-up at joints to prevent leakage of cement paste.

Fabricate forms for easy removal without hammering or prying against concrete surfaces. Provide crush plates or wrecking plates where stripping may damage cast concrete surfaces. Provide top forms for inclined surfaces where slope is too steep to place concrete with bottom forms only. Kerf wood inserts for forming keyways, reglets, recesses, and the like, to prevent swelling and for easy removal.

Provide temporary openings where interior area of formwork is inaccessible for cleanout, for inspection before concrete placement, and for placement of concrete. Securely brace temporary openings and set tightly to forms to prevent loss of concrete mortar. Locate temporary openings on forms at inconspicuous locations.

Chamfer exposed corners and edges as indicated, using wood, metal, PVC, or rubber chamfer strips fabricated to produce uniform smooth lines and tight edge joints.

Provisions for Other Trades: Provide openings in concrete formwork to accommodate work of other trades. Determine size and location of openings, recesses, and chases from trades providing such items. Accurately place and securely support items built into forms. Other trades shall provide location and size of openings. The forms for such openings shall be constructed and set in place under this section.

Cleaning and Tightening: Thoroughly clean forms and adjacent surfaces to receive concrete. Remove chips, wood, sawdust, dirt, or other debris just before concrete is placed. Retightening forms and bracing after concrete placement is required to eliminate mortar leaks and maintain proper alignment.

VAPOR RETARDER INSTALLATION:

Following leveling and tamping of granular base for slabs on grade, place vapor retarder sheeting with longest dimension parallel with direction of pour.

Lap joints 6" and seal with appropriate tape.

PLACING REINFORCEMENT:

Comply with Concrete Reinforcing Steel Institute's recommended practice for "Placing Reinforcing Bars", for details and methods of reinforcement placement and supports, and as herein specified.

Avoid cutting or puncturing vapor retarder during reinforcement placement and concreting operations.

Clean reinforcement of loose rust and mill scale, earth, ice, and other materials which reduce or destroy bond with concrete.

Accurately position, support, and secure reinforcement against displacement by formwork, construction, or concrete placement operations. Locate and support reinforcing by metal chairs, runners, bolsters, spacers, and hangers, as required.

Place reinforcement to obtain at least minimum coverages for concrete protection. Arrange, space, and securely tie bars and bar supports to hold reinforcement in position during concrete placement operations. Set wire ties so ends are directed into concrete, not toward exposed concrete surfaces.

Install welded wire fabric in as long lengths as practicable. Lap adjoining pieces at least one full mesh and lace splices with wire. Offset end laps in adjacent widths to prevent continuous laps in either direction.

JOINTS:

Construction Joints: Locate and install construction joints as indicated or, if not indicated, locate so as not to impair strength and appearance of the structure, as acceptable to Engineer.

Place construction joints perpendicular to main reinforcement. Continue reinforcement across construction joints, except as otherwise indicated.

Waterstops: Provide waterstops in construction joints as indicated. Install waterstops to form continuous diaphragm in each joint. Make provisions to support and protect exposed waterstops during progress of work. Fabricate field joints in waterstops in accordance with manufacturer's printed instructions.

Isolation Joints in Slabs-on-Ground: Construct isolation joints in slabs-on-ground at points of contact between slabs-on-ground and vertical surfaces, such as column pedestals, foundation walls, grade beams, and elsewhere as indicated.

INSTALLATION OF EMBEDDED ITEMS:

General: Set and build into work anchorage devices and other embedded items required for other work that is attached to, or supported by, cast-in-place concrete. Use setting drawings, diagrams, instructions, and directions provided by suppliers of items to be attached thereto.

PREPARATION OF FORM SURFACES:

Clean re-used forms of concrete matrix residue, repair and patch as required to return forms to acceptable surface condition.

Coat contact surfaces of forms with a form-coating compound before reinforcement is placed.

Thin form-coating compounds only with thinning agent of type, amount, and under conditions of form-coating compound manufacturer's directions. Do not allow excess form-coating material to accumulate in forms or to come into contact with in-place concrete surfaces against which fresh concrete will be placed. Apply in compliance with manufacturer's instructions.

CONCRETE PLACEMENT:

Preplacement Inspection: Before placing concrete, inspect and complete formwork installation, reinforcing steel, and items to be embedded or cast-in. Notify other crafts to permit installation of their work; cooperate with other trades in setting such work. Moisten wood forms immediately before placing concrete where form coatings are not used.

Apply temporary protective covering to lower 2' of finished walls adjacent to poured floor slabs and similar conditions, and guard against spattering during placement.

General: Comply with ACI 304 "Recommended Practice for Measuring, Mixing, Transporting, and Placing Concrete", and as herein specified.

Deposit concrete continuously or in layers of such thickness that no concrete will be placed on concrete which has hardened sufficiently to cause the formation of seams or planes of weakness. If a section cannot be placed continuously, provide construction joints as herein specified. Deposit concrete as nearly as practicable to its final location to avoid segregation.

Placing Concrete in Forms: Deposit concrete in forms in horizontal layers not deeper than 24 inches and in a manner to avoid inclined construction joints. Where placement consists of several layers, place each layer while preceding layer is still plastic to avoid cold joints.

Consolidate placed concrete by mechanical vibrating equipment supplemented by hand spading, rodding, or tamping. Use equipment and procedures for consolidation of concrete in accordance with ACI 309.

Do not use vibrators to transport concrete inside forms. Insert and withdraw vibrators vertically at uniformly spaced locations not farther than visible effectiveness of machine. Place vibrators to rapidly penetrate placed layer and at least 6 inches into preceding layer. Do not insert vibrators into lower layers of concrete that have begun to set. At each insertion

limit duration of vibration to time necessary to consolidate concrete and complete embedment of reinforcement and other embedded items without causing segregation of mix.

Placing Concrete Slabs: Deposit and consolidate concrete slabs in a continuous operation, within limits of construction joints, until the placing of a panel or section is completed.

Consolidate concrete during placing operations so that concrete is thoroughly worked around reinforcement and other embedded items and into corners.

Bring slab surfaces to correct level with straightedge and strikeoff. Use bull floats or darbies to smooth surface, free of humps or hollows. Do not disturb slab surfaces prior to beginning finishing operations.

Maintain reinforcing in proper position during concrete placement operations.

Cold Weather Placing: Protect concrete work from physical damage or reduced strength which could be caused by frost, freezing actions, or low temperatures, in compliance with ACI 306 and as herein specified.

When air temperature has fallen to or is expected to fall below 40 degrees F (4 degrees C), uniformly heat water and aggregates before mixing to obtain a concrete mixture temperature of not less than 50 degrees F (10 degrees C), and not more than 80 Degrees F (27 degrees C) at point of placement.

Do not use frozen materials or materials containing ice or snow. Do not place concrete on frozen subgrade or on subgrade containing frozen materials.

Do not use calcium chloride, salt, and other materials containing antifreeze agents or chemical accelerators, unless otherwise accepted in mix designs.

Hot Weather Placing: When hot weather conditions exist that would seriously impair quality and strength of concrete, place concrete in compliance with ACI 305 and as herein specified.

Cool ingredients before mixing to maintain concrete temperature at time of placement below 90 degrees F (32 degrees C). Mixing water may be chilled, or chopped ice may be used to control temperature provided water equivalent of ice is calculated to total amount of mixing water. Use of liquid nitrogen to cool concrete is Contractor's option.

Cover reinforcing steel with water-soaked burlap if it becomes too hot, so that steel temperature will not exceed the ambient air temperature immediately before embedment in concrete.

Fog spray forms, reinforcing steel, and subgrade just before concrete is placed.

Use water-reducing retarding admixture (Type D) when required by high temperatures, low humidity, or other adverse placing conditions.

FINISH OF FORMED SURFACES:

Rough Form Finish: For formed concrete surfaces not exposed-to-view in the finish work or by other construction, unless otherwise indicated. This is the concrete surface having texture imparted by form facing material used, with tie holes and defective areas repaired and patched and fins and other projections exceeding 1/4 inch in height rubbed down or chipped off.

Smooth Form Finish: For formed concrete surfaces exposed-to-view, or that are to be covered with a coating material applied directly to concrete, or a covering material applied directly to concrete, such as waterproofing, dampproofing, veneer plaster, painting, or other similar system. This is as-cast concrete surface obtained with selected form facing material, arranged orderly and symmetrically with a minimum of seams. Repair and patch defective areas with fins or other projections completely removed and smoothed.

Grout Cleaned Finish: Provide grout cleaned finish to scheduled concrete surfaces which have received smooth form finish treatment.

Combine one part portland cement to 1-1/2 parts fine sand by volume, and mix with water to consistency of thick paint. Proprietary additives may be used at Contractor's option. Blend standard portland cement and white portland cement, amounts determined by trial patches, so that final color of dry grout will match adjacent surfaces.

Thoroughly wet concrete surfaces and apply grout to coat surfaces and fill small holes. Remove excess grout by scraping and rubbing with clean burlap. Keep damp by fog spray for at least 36 hours after rubbing.

Related Unformed Surfaces: At tops of walls, horizontal offsets, and similar unformed surfaces occurring adjacent to formed surfaces, strike-off smooth and finish with a texture matching adjacent formed surfaces. Continue final surface treatment of formed surfaces uniformly across adjacent unformed surfaces, unless otherwise indicated.

MONOLITHIC SLAB FINISHES:

ASTM E 1155, "Standard Test Method for Determining Floor Flatness and Levelness Using the "F Number System (inch-pound-units)", shall be used for these finishes as follows:

Scratch Finish: Apply scratch finish to monolithic slab surfaces that are to receive concrete floor topping or mortar setting beds for tile, portland cement terrazzo, and other bonded applied cementitious finish flooring material, and as otherwise indicated.

After placing slabs, plane surface to tolerances for floor flatness (FF) of 15 and floor levelness (FL) of 13. Slope surfaces uniformly to drains where required. After leveling, roughen surface before final set, with stiff brushes, brooms, or rakes.

Float Finish: Apply float finish to monolithic slab surface to receive trowel finish and other finishes as hereinafter specified, and slab surfaces which are to be covered with membrane or elastic waterproofing membrane or elastic roofing, or sand-bed terrazzo, and as otherwise indicated.

After screeding, consolidating, and leveling concrete slabs, do not work surface until ready for floating. Begin floating when surface water has disappeared or when concrete has stiffened sufficiently to permit operation of power-driven floats, or both. Consolidate surface with power-driven floats, or by hand-floating if area is small or inaccessible to power units. Check and level surface plane to tolerances of FF 18 - FL 15. Cut down high spots and fill low spots. Uniformly slope surfaces to drains. Immediately after leveling, refloat surface to a uniform, smooth, granular texture.

Trowel Finish: Apply trowel finish to monolithic slab surfaces to be exposed-to-view, and slab surfaces to be covered with resilient flooring, carpet, ceramic or quarry tile, paint, or other thin film finish coating system.

After floating, begin first trowel finish operation using a power-driven trowel. Begin final troweling when surface produces a ringing sound as trowel is moved over surface. Consolidate concrete surface by final hand-troweling operation, free of trowel marks, uniform in texture and appearance, and with surface leveled to tolerances of FF 20 - FL 17. Grind smooth surface defects which would telegraph through applied floor covering system.

Trowel and Fine Broom Finish: Where ceramic or quarry tile is to be installed with thin-set mortar, apply trowel finish as specified, then immediately follow with slightly scarifying surface by fine brooming.

Non-Slip Broom Finish: Apply non-slip broom finish to exterior concrete platforms, steps, and ramps, and elsewhere as indicated.

Immediately after float finishing, slightly roughen concrete surface by brooming with fiber bristle broom perpendicular to main traffic route. Coordinate required final finish with Engineer before application.

CONCRETE CURING AND PROTECTION:

General: Protect freshly placed concrete from premature drying and excessive cold or hot temperatures.

Start initial curing as soon as free water has disappeared from concrete surface after placing and finishing. Weather permitting, keep continuously moist for not less than 7 days.

Begin final curing procedures immediately following initial curing and before concrete has dried. Continue final curing for at least 7 days in accordance with ACI 301 procedures. Avoid rapid drying at end of final curing period.

Curing Methods: Perform curing of concrete by curing and sealing compound, by moist curing, by moisture-retaining cover curing, and by combinations thereof, as herein specified.

Provide moisture curing by the following methods:

- Keep concrete surface continuously wet by covering with water.
- Continuous water-fog spray.
- Covering concrete surface with specified absorptive cover, thoroughly saturating cover with water and keeping continuously wet. Place absorptive cover to provide

coverage of concrete surfaces and edges, with 4-inch lap over adjacent absorptive covers.

Provide moisture-cover curing as follows:

- Cover concrete surfaces with moisture-retaining cover for curing concrete, placed in widest practicable width with sides and ends lapped at least 3 inches and sealed by waterproof tape of adhesive. Immediately repair any holes or tears during curing period using cover material and waterproof tape.

Provide curing slabs and sealing compounds to exposed interior slabs and to exterior slabs, walks, and curbs, as follows:

- Apply specified curing and sealing compound to concrete slabs as soon as final finishing operations are complete (within 2 hours). Apply uniformly in continuous operation by power-spray or roller in accordance with manufacturer's directions. Recoat areas subjected to heavy rainfall within 3 hours after initial application. Maintain continuity of coating and repair damage during curing period.

Do not use membrane curing compounds on surfaces which are to be covered with coating material applied directly to concrete, liquid floor hardener, waterproofing, dampproofing, membrane roofing, flooring (such as ceramic or quarry tile, glue-down carpet), painting, and other coatings and finish materials, unless otherwise acceptable to Engineer.

Curing Formed Surfaces: Cure formed concrete surfaces, including undersides of beams, supported slabs, and other similar surfaces by moist curing with forms in place for full curing period or until forms are removed. If forms are removed, continue curing by methods specified above, as applicable.

Curing Unformed Surfaces: Cure unformed surfaces, such as slabs, floor topping, and other flat surfaces by application of appropriate curing method.

Final cure concrete surfaces to receive liquid floor hardener or finish flooring by use of moisture-retaining cover, unless otherwise directed.

Sealer and Dustproofers: Apply a second coat of specified curing and sealing compound only to surfaces given a first coat.

SHORES AND SUPPORTS:

Remove shoring from ground to roof for structures 4 stories or less, unless otherwise permitted.

Remove shores and reshore in a planned sequence to avoid damage to partially cured concrete. Locate and provide adequate reshoring to safely support work without excessive stress or deflection.

Keep shores in place a minimum of 15 days after placing upper tier, and longer if required, until concrete has attained its required 28-day strength and heavy loads due to construction operations have been removed.

REMOVAL OF FORMS:

Formwork not supporting weight of concrete, such as sides of beams, walls, columns, and similar parts of the work, may be removed after cumulatively curing at not less than 50 degrees F (10 degrees C) for 24 hours after placing concrete, provided concrete is sufficiently hard to not be damaged by form removal operations, and provided curing and protection operations are maintained.

Form facing material may be removed 4 days after placement, only if shores and other vertical supports have been arranged to permit removal of form facing material without loosening or disturbing shores and supports.

RE-USE OF FORMS:

Clean and repair surfaces of forms to be re-used in work. Split, frayed, delaminated, or otherwise damaged from facing material will not be acceptable for exposed surfaces. Apply new form coating compound as specified for new formwork.

When forms are extended for successive concrete placement, thoroughly clean surfaces, remove fins and laitance, and tighten forms to close joints. Align and secure joint to avoid offsets. Do not use "patched" forms for exposed concrete surfaces, except as acceptable to Engineer.

MISCELLANEOUS CONCRETE ITEMS:

Filling-In: Fill-in holes and openings left in concrete structures for passage of work by other trades, unless otherwise shown or directed, after work of other trades is in place. Mix, place, and cure concrete as herein specified, to blend with in-place construction. Provide other miscellaneous concrete filling shown or required to complete work.

Curbs: Provide monolithic finish to interior curbs by stripping forms while concrete is still green and steel troweling surfaces to a hard, dense finish with corners, intersections, and terminations slightly rounded.

Equipment Bases and Foundations: Provide machine and equipment bases and foundations, as shown on drawings. Set anchor bolts for machines and equipment to template at correct elevations, complying with certified diagrams or templates of manufacturer furnishing machines and equipment.

Grout base plates and foundations as indicated, using specified non-shrink grout. Use non-metallic grout for exposed conditions, unless otherwise indicated.

Reinforced Masonry: Provide concrete grout for reinforced masonry lintels and bond beams where indicated on drawings and as scheduled including filling of concrete modular unit cavities where called for on plans. Maintain accurate location of reinforcing steel during concrete placement.

CONCRETE SURFACE REPAIRS:

Patching Defective Areas: Repair and patch defective areas with cement mortar immediately after removal of forms, when acceptable to Engineer.

Cut out honeycomb, rock pockets, voids over 1/4 inch in any dimension, and holes left by tie rods and bolts, down to solid concrete but, in no case to a depth of less than 1 inch. Make edges of cuts perpendicular to the concrete surface. Thoroughly clean, dampen with water, and brush-coat the area to be patched with specified bonding agent. Place patching mortar after bonding compound has dried.

Repair of Formed Surfaces: Remove and replace concrete having defective surfaces if defects cannot be repaired to satisfaction of Engineer. Surface defects, as such, include color and texture irregularities, cracks, spalls, air bubbles, honeycomb, rock pockets; fins and other projections on surface; and stains and other discolorations that cannot be removed by cleaning. Flush out form tie holes, fill with dry pack mortar, or precast cement cone plugs secured in place with bonding agent.

Repair concealed formed surfaces, where possible, that contain defects that affect the durability of concrete. If defects cannot be repaired, remove and replace concrete.

Repair of Unformed Surfaces: Test unformed surfaces, such as monolithic slabs, for smoothness and verify surface plane to tolerances specified for each surface and finish. Correct low and high areas as herein specified. Test unformed surfaces slopped to drain for trueness of slope, in addition to smoothness using a template having required slope.

Repair finished unformed surfaces that contain defects which affect durability of concrete. Surface defects, as such, include crazing cracks in excess of 0.01 inch wide or which penetrate to reinforcement or completely through non-reinforced sections regardless of width, spalling, pop-outs, honeycomb, rock pockets, and other objectionable conditions.

Correct high areas in unformed surfaces by grinding, after concrete has cured at least 14 days.

Correct low areas in unformed surfaces during or immediately after completion of surface finishing operations by cutting out low areas and replacing with fresh concrete. Finish repaired areas to blend into adjacent concrete. Proprietary patching compounds may be used when acceptable to Engineer.

Repair defective areas, except random cracks and single holes not exceeding 1 inch diameter, by cutting out and replacing with fresh concrete. Remove defective areas to sound concrete with clean, square cuts and expose reinforcing steel with at least 3/4 inch clearance all around. Dampen concrete surfaces in contact with patching concrete and apply bonding compound. Mix patching concrete of same materials to provide concrete of same type or class as original concrete. Place, compact, and finish to blend with adjacent finished concrete. Cure in same manner as adjacent concrete.

Perform structural repairs with prior approval of Structural Engineer for method and procedure, using specified epoxy adhesive and mortar.

Repair methods not specified above may be used, subject to acceptance of Engineer.

QUALITY CONTROL TESTING DURING CONSTRUCTION:

Sampling and testing for quality control during placement of concrete may include the following, as directed by Engineer.

Sampling Fresh Concrete: ASTM C 172, except modified for slump to comply with ASTM C 94.

Slump: ASTM C 143, each type of concrete, and additional tests when concrete consistency seems to have changed.

Concrete Temperature: Test hourly when air temperature is 40 degrees F (4 degrees C) and below, and when 80 degrees F (27 degrees C) and above, and each time a set of compression test specimens are made.

Compression Test Specimen: ASTM C 31, one set of 3 standard cylinders for each compressive strength test, unless otherwise directed. Mold and store cylinders for laboratory cured test specimens except when field-cure test specimens are required.

Compressive Strength Tests: ASTM C 39, one set for each day's pour plus additional sets for each 50 cubic yards over and above the first 25 cubic yards of each concrete class placed in any one day; one specimen tested at 7 days, two specimens tested at 28 days.

When frequency of testing will provide less than 5 strength tests for a given class of concrete, conduct testing from at least 5 randomly selected batches or from each batch if fewer than 5 are used.

Test results will be reported in writing to Structural Engineer and Contractor within 24 hours after tests. Reports of compressive strength tests shall contain the project identification name and number, date of concrete placement, name of concrete testing service, concrete type and class, location of concrete batch in structure, design compressive strength at 28 days, concrete mix proportions and materials; compressive breaking strength and type of break for both 7-day tests and 28-day tests.

Nondestructive Testing: Impact hammer, sonoscope, or other nondestructive device may be permitted but shall not be used as the sole basis for acceptance or rejection.

Additional Tests: The testing service will make additional tests of in-place concrete when test results indicate specified concrete strengths and other characteristics have not been attained in the structure, as directed by Engineer. Testing service may conduct tests to determine adequacy of concrete by cored cylinders complying with ASTM C 42, or by other methods as directed. Contractor shall pay for such tests when unacceptable concrete is verified.

END OF SECTION 03310

HUGH THOMAS DRIVE IMPROVEMENTS CALLAWAY, FLORIDA

PREPARED FOR:
CITY OF CALLAWAY



ADDRESS
6601 EAST HIGHWAY 22
CALLAWAY, FLORIDA 32404
PHONE: (850) 871-6000

CITY OF CALLAWAY OF CITY OFFICIALS:

- MS. PAMN HENDERSON, MAYOR
 - MR. SCOTT DAVIS, WARD I COMMISSIONER
 - MR. DAVID GRIGGS, WARD II COMMISSIONER
 - MR. RON FAIRBANKS, WARD III COMMISSIONER
 - MR. MIKE JONES, WARD IV COMMISSIONER
-
- MR. KEITH "EDDIE" COOK, CITY MANAGER
 - MR. BILL FRYE, PUBLIC WORKS DIRECTOR

PREPARED BY:

PANHANDLE ENGINEERING, INC.

ENVIRONMENTAL ENGINEERS • CIVIL ENGINEERS • LAND PLANNERS
3005 South Highway 77 Lynn Haven, Florida 32444
(850) 763-5200 Fax (850) 769-0730 www.panhandleengineering.com



ADDRESS: HUGH THOMAS DR. - (09-4S-13W)
LAT - 30° 09' 02"
LONG - 85° 33' 17"

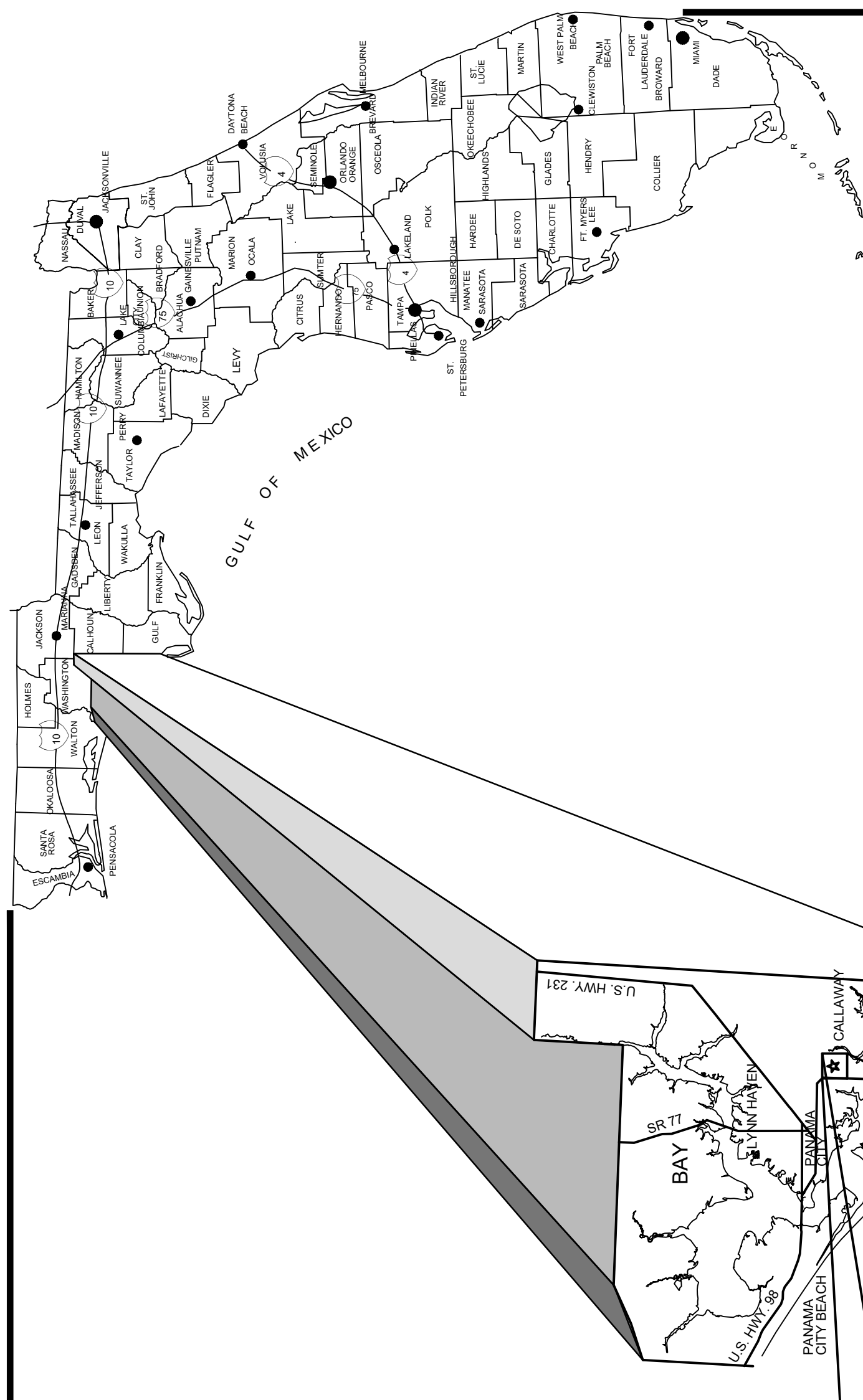

ISSUE FOR BID

SEPTEMBER 2019
PROJECT No. 26023

DRAWING INDEX

- | No. - | TITLE |
|-------|---|
| 1 - | EXISTING CONDITIONS AND DEMOLITION PLAN |
| 2 - | KEY SHEET |
| 3 - | PLAN SHEET |
| 4 - | PLAN SHEET |
| 5 - | EROSION CONTROL PLAN |
| 8 - | CONSTRUCTION DETAILS |
| 7 - | CONSTRUCTION DETAILS |
| 9 - | STORM WATER POLLUTION PREVENTION PLAN |

Always call 811 two full business days before you dig to have underground utilities located and marked.

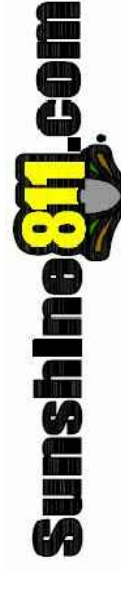

ENGINEER OF RECORD: DOUG CROOK, P.E. (FL REG NO. 66556)
QA/QC: CHRIS FOREHAND, P.E. (FL REG NO. 58028)

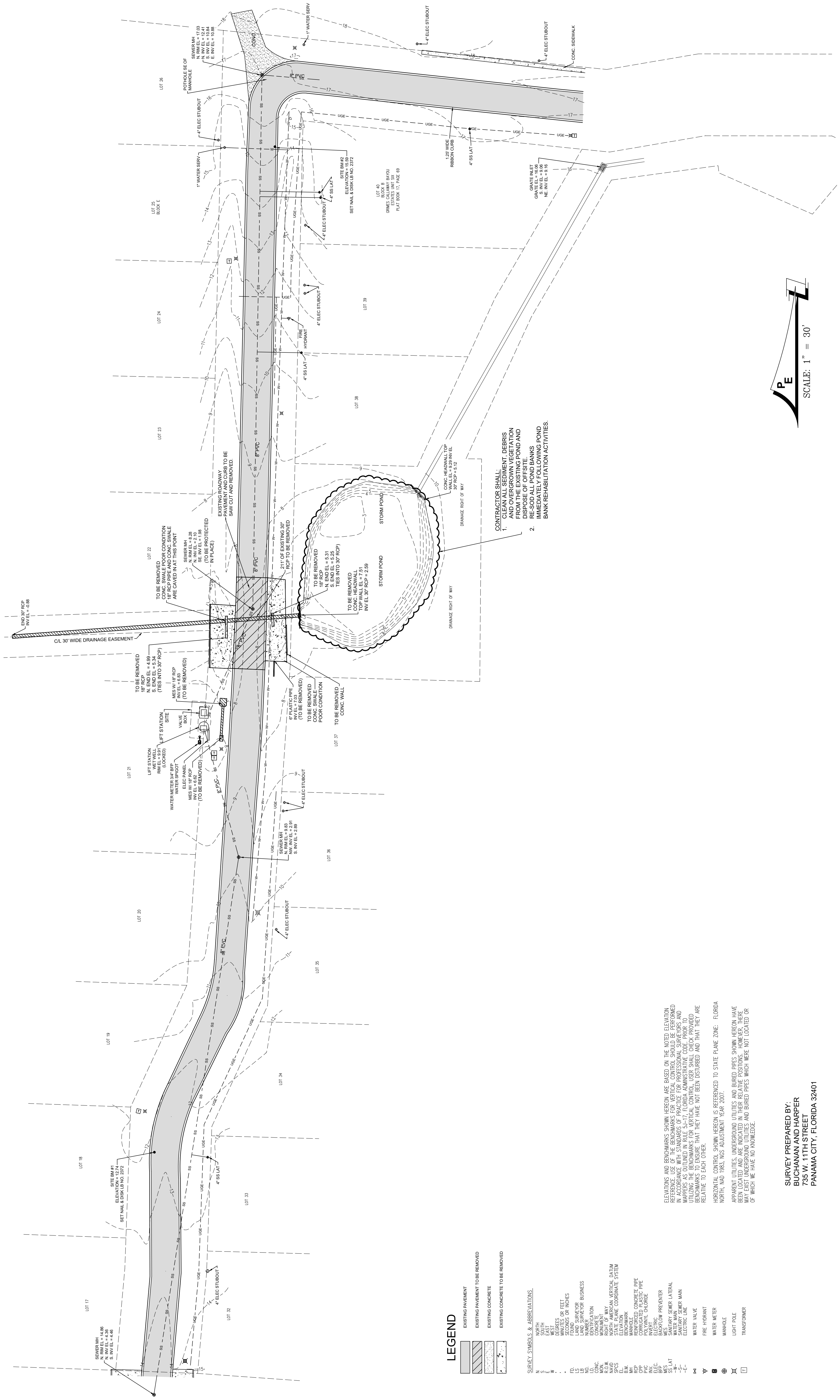

CONTRACTOR SHALL:
 1. CLEAN ALL SEDIMENT, DEBRIS AND ORGANIC VEGETATION FROM THE EXISTING POND AND DISPOSE OF OFFSITE.
 2. RE-SOD ALL POND BANKS IMMEDIATELY FOLLOWING POND BANK REHABILITATION ACTIVITIES.

LEGEND

- [Hatched Box] EXISTING PAVEMENT
- [Dotted Box] EXISTING PAVEMENT TO BE REMOVED
- [Stippled Box] EXISTING CONCRETE
- [Cross-hatched Box] EXISTING CONCRETE TO BE REMOVED

- SURVEY SYMBOLS & ABBREVIATIONS:**
- N NORTH
 - E EAST
 - S SOUTH
 - W WEST
 - MINUTES
 - SECONDS OR FEET
 - LAND SURVEYOR
 - LAND SURVEYOR BUSINESS
 - MONUMENT
 - IDENTIFICATION
 - RIGHT OF WAY
 - STATE PLANE COORDINATE SYSTEM
 - ELEVATION
 - MANHOLE
 - REINFORCED CONCRETE PIPE
 - PVC
 - POLYETHYLENE GLYCOL
 - ELECTRIC
 - BACKFLOW PREVENTER
 - SAINTARY SEWER LATERAL
 - WATER MAIN
 - WATER MAIN
 - ELECTRIC LINE
 - WATER VALVE
 - FIRE HYDRANT
 - WATER METER
 - MANHOLE
 - LIGHT POLE
 - TRANSFORMER

ELEVATIONS AND BENCHMARKS SHOWN HEREON ARE BASED ON THE NOTED ELEVATION BENCHMARK. THE USER SHALL VERIFY THE LOCATION OF BENCHMARKS AND BENCHMARKS IN ACCORDANCE WITH STANDARDS OF PRACTICE FOR PROFESSIONAL SURVEYORS AND MAPPERS AS OUTLINED IN RULE S-17, FLORIDA ADMINISTRATIVE CODE. PRIOR TO UTILIZING THE BENCHMARKS FOR VERTICAL CONTROL, USER SHALL CHECK PROVIDED BENCHMARKS TO ENSURE THAT THEY HAVE NOT BEEN DISTURBED AND THAT THEY ARE RELATIVE TO EACH OTHER.
 HORIZONTAL CONTROL SHOWN HEREON IS REFERENCED TO STATE PLANE ZONE: FLORIDA NORTH, NAD 1983, NGS ADJUSTMENT YEAR 2007.
 APPARENT UTILITIES, UNDERGROUND UTILITIES AND BURIED PIPES SHOWN HEREON HAVE BEEN LOCATED AND ARE INDICATED IN THEIR RELATIVE POSITIONS. HOWEVER, THERE MAY EXIST UNDERGROUND UTILITIES AND BURIED PIPES WHICH WERE NOT LOCATED OR OF WHICH WE HAVE NO KNOWLEDGE.

SURVEY PREPARED BY:
 BUCHANAN AND HARPER
 735 W. 11TH STREET
 PANAMA CITY, FLORIDA 32401

REV	DATE	BY	REVISIONS

SCALE	AS NOTED
DESIGNED BY:	CBF
DRAWN BY:	JAH
REVIEWED BY:	CBF
ISSUE DATE:	SEPTEMBER 2019
ACAD FILE NAME:	26023.dwg

PANHANDLE ENGINEERING, INC.
 ENVIRONMENTAL ENGINEERS • CIVIL ENGINEERS • LAND PLANNERS
 5405 South Highway 77, Panama City, Florida 32404
 (850) 753-9200 Fax: (850) 753-0730 www.panhandleengineering.com

EXISTING CONDITIONS AND DEMOLITION PLAN
HUGH THOMAS DRIVE IMPROVEMENTS
CALLAWAY, FLORIDA

JAMES H. BUCHANAN, P.E. 33197
 CHRISTOPHER B. FORBES, P.E. 50298
 STEPHEN E. PIERCE, P.E. 37668
 J. DREW GRIFFIN, P.E. 60668

PROJECT NUMBER
26023

SHEET NUMBER
1

DPR CERTIFICATION FEB-2020

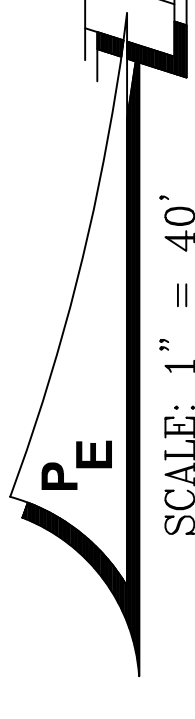

SCALE: 1" = 40'

LEGEND

- EXISTING CONCRETE
- EXISTING PAVEMENT
- PROPOSED CONCRETE

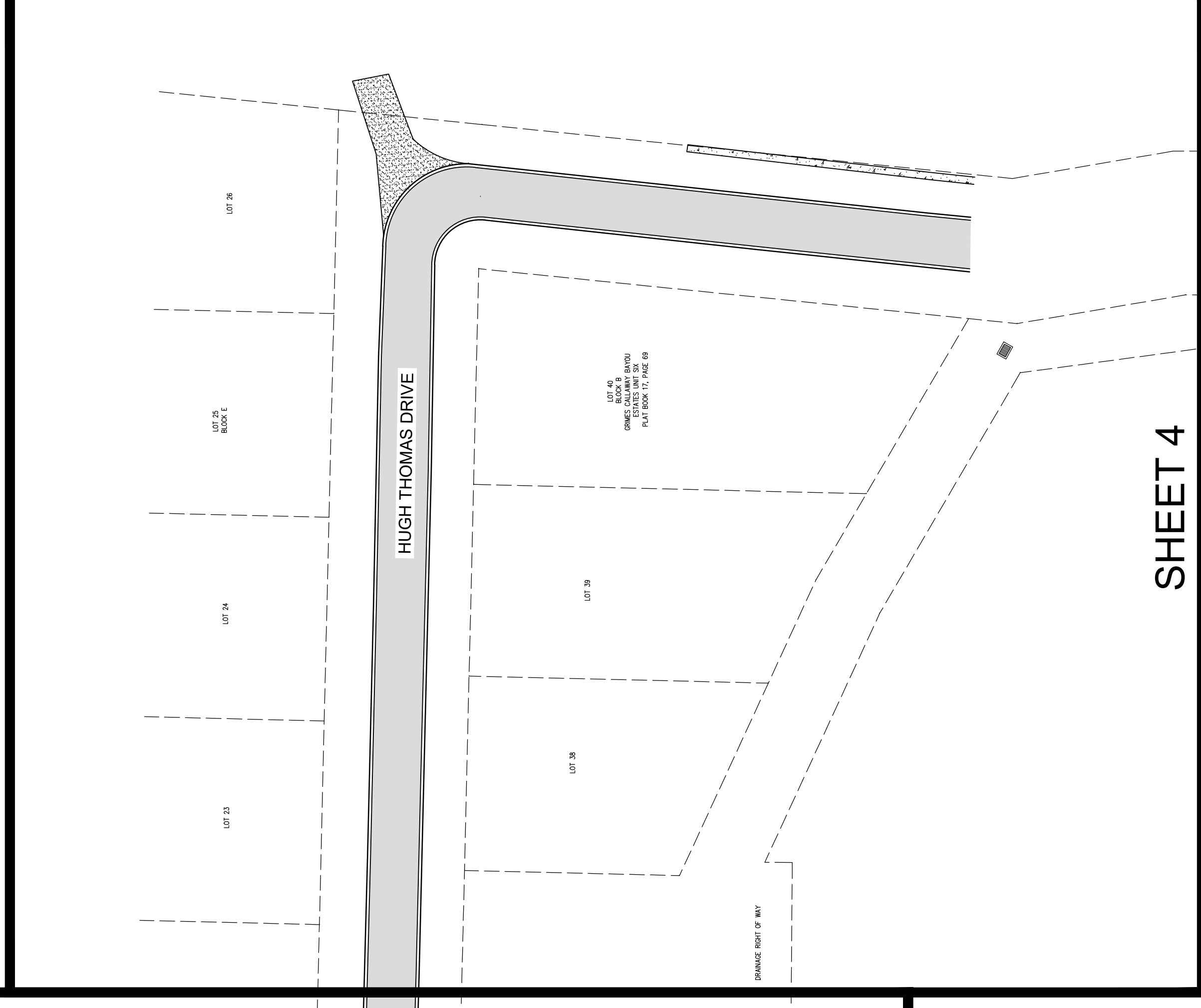
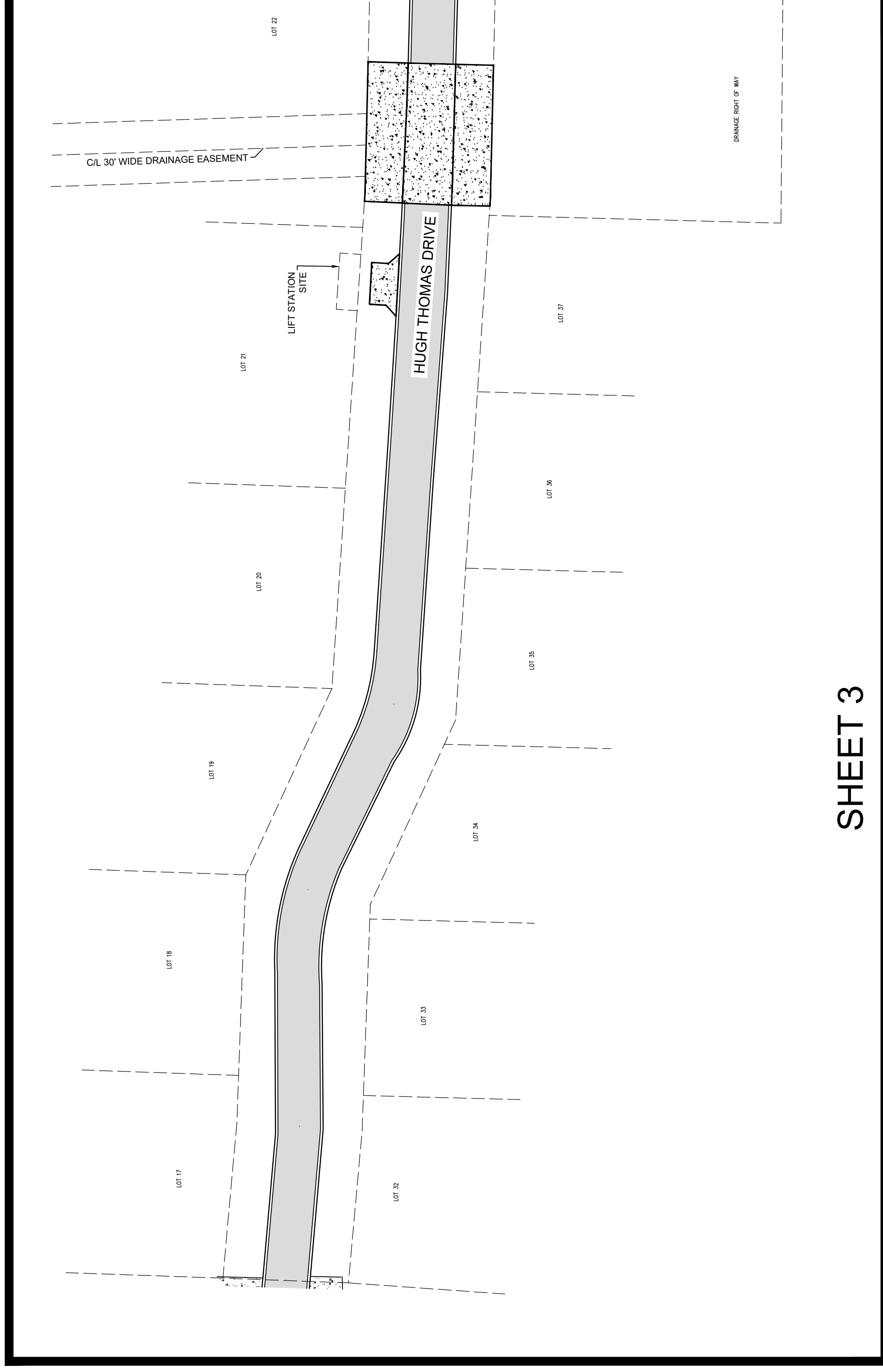

REV	DATE	BY	REVISIONS
NOT			RELEASED FOR CONSTRUCTION BY: DATE:

SCALE:	AS NOTED
DESIGNED BY:	CBF
DRAWN BY:	JAH
REVIEWED BY:	CBF
ISSUE DATE:	SEPTEMBER 2019
ACAD FILE NAME:	26023.dwg

PANHANDLE ENGINEERING, INC.
 ENVIRONMENTAL ENGINEERS • CIVIL ENGINEERS • LAND PLANNERS
 5405 South Highway 77 • Ft. Lauderdale, Florida 33304
 (800) 768-9200 • Fax (800) 768-0730 • www.panhandleengineering.com

KEY SHEET
HUGH THOMAS DRIVE
IMPROVEMENTS
CALLAWAY, FLORIDA

James H. Shorina, P.E. 03197
 Christopher B. Forehand, P.E. 9028
 Stephen E. Price, P.E. 71666
 J. Doug Gandy, P.E. 6966
 DPR CERTIFICATION #EB-708

SHEET NUMBER
2
 PROJECT NUMBER
26023

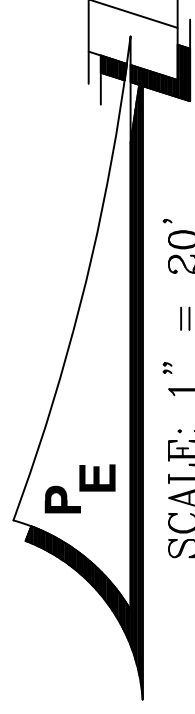

SCALE: 1" = 20'

DRAINAGE PIPE TABLE					
NO.	SIZE	DESCRIPTION	LF	SLOPE	INVERTS
DP-01	14"x18"	Horizontal Elliptical Concrete Pipe	211'	0.15%	EX+ = -0.88' DS-01 = -0.87'
DP-02	14"x27"	Horizontal Elliptical Concrete Pipe	38'	0.32%	DS-02 = 3.07' DS-03 = 2.88'
DP-03	18"	Concrete Pipe	54'	0.70%	DS-03 = 2.88' DS-04 = 2.57'
DP-04	18"	Concrete Pipe	21'	7.28%	DS-04 = 2.57' DS-05 = 7.52'
DP-05	14"x27"	Horizontal Elliptical Concrete Pipe	30'	0.83%	DS-05 = 7.52' DS-07 = 7.07'

DRAINAGE STRUCTURE TABLE			
NO.	STRUCTURE TYPE	TOP ELEV.	PIPE INVERTS
DS-01	Index No. 232 - Invert 1, Type E	6.50'	(W) -0.06' (DP-01)
DS-02	Index No. 232 - Invert 2, Type C	6.50'	(E) 3.00' (DP-02)
DS-03	Index No. 232 - Invert 3, Type C	6.50'	(W) 2.88' (DP-02) (SE) 2.88' (DP-03)
DS-04	Index No. 201 - Type 7 Manhole Cover (Cast Iron, Round Bottom)	9.00'	(NW) 2.57' (DP-03) (N) 2.57' (DP-04)
DS-05	Index No. 272 - Invert 1, Type C	2.71'	(S) 1.09' (DP-04)
DS-06	Index No. 272 - Invert 2, Type C	8.86'	(N) 7.25' (DP-05)
DS-07	Index No. 272 - Invert 3, Type C	8.46'	(S) 7.06' (DP-05)



LEGEND

SURVEY SYMBOLS & ABBREVIATIONS:

- N, S, E, W
- MINUTES OR FEET
- SECONDS OR INCHES
- LAND SURVEYOR BUSINESS IDENTIFICATION
- CONSENT
- RIGHT OF WAY
- R.O.W.
- STATE PLANS
- MANHOLE
- REMOVED CONCRETE PIPE
- INVERT
- BACKFLOW PREVENTER
- SANITARY SEWER LATERAL
- WATER MAIN
- ELECTRIC LINE
- WATER VALVE
- FIRE HYDRANT
- WATER METER
- MANHOLE
- LIGHT POLE
- TRANSFORMER

NOTED ON PLANS:

- PROPOSED STORM PIPE
- EXISTING SANITARY MANHOLE
- EXISTING UNDERGROUND ELECTRIC
- EXISTING WATER MAIN
- EXISTING SANITARY SEWER
- STORM DRAIN STRUCTURE (s.#)
- STORM DRAIN PIPE (s.#)
- WATER METER
- EXISTING CONCRETE
- EXISTING PAVEMENT
- PROPOSED CONCRETE
- LIMITS OF SOD PLACEMENT

- SITE NOTES:**
- ABOVE GROUND STRUCTURES, ETC., ARE SHOWN ON THIS SHEET.
 - ALL TRAFFIC STRIPING TO BE THERMOPLASTIC PER STANDARD SPECIFICATIONS FOR ROAD AND BRIDGE CONSTRUCTION SEC 711. (WAIT MINIMUM OF 30 DAYS AFTER ASPHALT CONCRETE PLACEMENT TO PLACE PERMANENT THERMOPLASTIC MARKING. TEMPORARY STRIPING TO BE PAINTED STOP BAR ONLY.)
 - ALL DISTURBED AREAS SHALL BE GRASSSED, HYDROSEED @ 4:1 & FLATTER SOD @ STEEPER THAN 4:1.
 - ALL SOD TO BE STAKED & PINNED.
 - NO DAYTIME LANE CLOSURES.
 - CONTRACTOR TO FIELD VERIFY ALL UTILITIES ABOVE OR BELOW GROUND AND NOTIFY ALL UTILITY COMPANIES 2 DAYS PRIOR TO CONSTRUCTION.
 - FOR MAINTENANCE OF TRAFFIC CONTROL, CONCRETE, ASPHALT, ETC., TO BE REMOVED AND DISPOSED 102-612 & 102-613 AS APPLICABLE.
 - ALL DEMOLISHED MATERIALS (i.e. SIGNS, CONCRETE, ASPHALT, ETC.) TO BE REMOVED AND DISPOSED RESPONSIBLY OF THE CONTRACTOR TO COORDINATE AND SCHEDULE ALL TESTS.

BORING DATA

LOCATION	GROUNDWATER LEVEL (BELOW FINISHED GRADE)	ESTIMATED SEASONAL HIGH GROUNDWATER LEVEL (BELOW FINISHED GRADE)
C-1	3.0 FEET	3.0 FEET
C-2	3.5 FEET	3.0 FEET
C-3	2.0 FEET	1.5 FEET

REV	DATE	BY	REVISIONS

RELEASED FOR CONSTRUCTION BY: DATE:

PANHANDLE ENGINEERING, INC.

ENVIRONMENTAL ENGINEERS • CIVIL ENGINEERS • LAND PLANNERS
 5405 South Highway 77, Houston, Texas 77059
 (850) 755-9200 Fax: (850) 755-0730 www.panhandleengineering.com

PLAN SHEET
HUGH THOMAS DRIVE IMPROVEMENTS
CALLAWAY, FLORIDA

James H. Shanna, P.E. 33187
 Christopher B. Forehand, P.E. 58298
 Stephen E. Price, P.E. 71668
 J. Doug Gentry, P.E. 68668

SHEET NUMBER **3**
 PROJECT NUMBER **26023**
 DFR CERTIFICATION # 26023

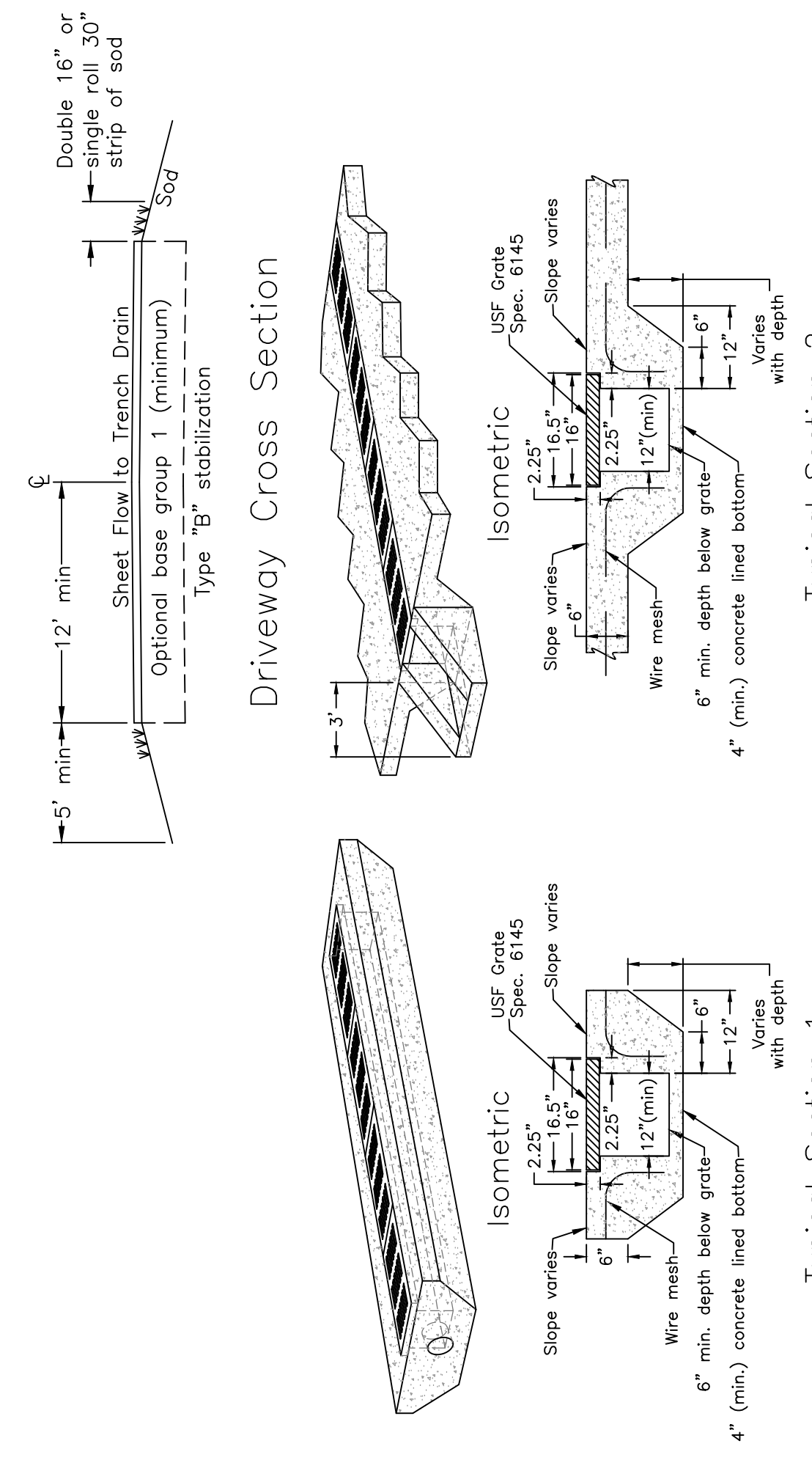
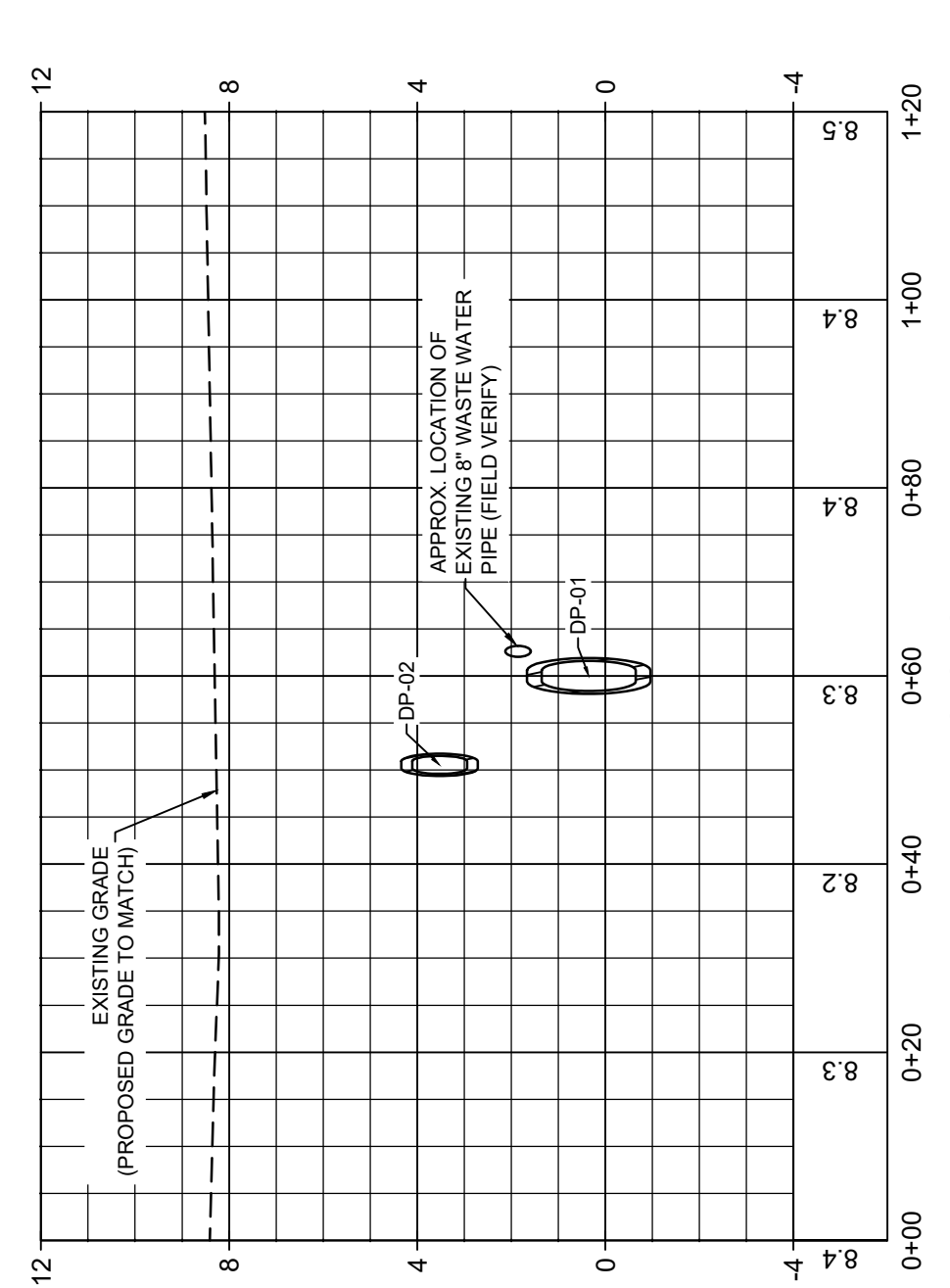
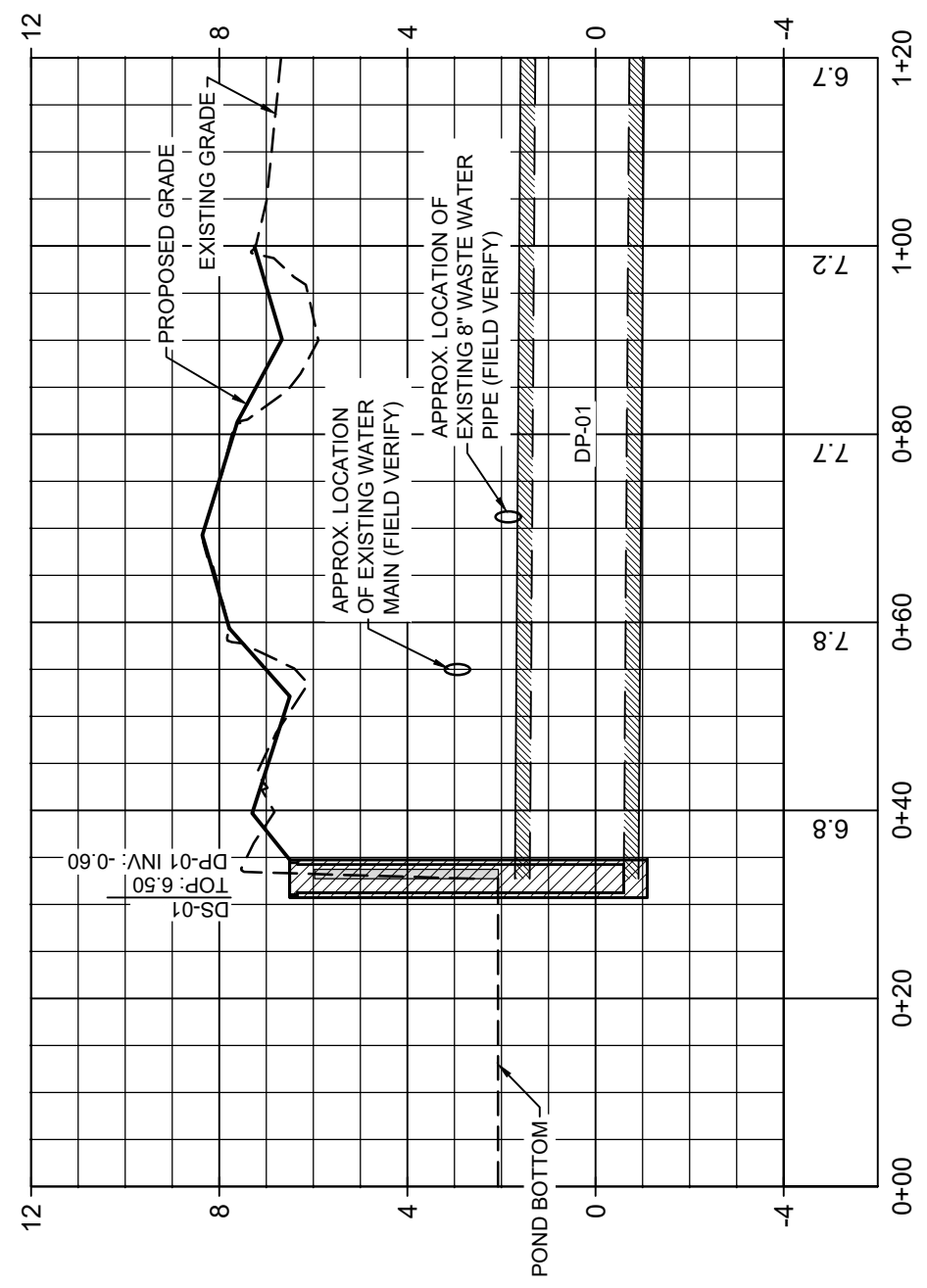

CONCRETE DRIVEWAY TRENCH DRAIN DETAIL
 NOT TO SCALE

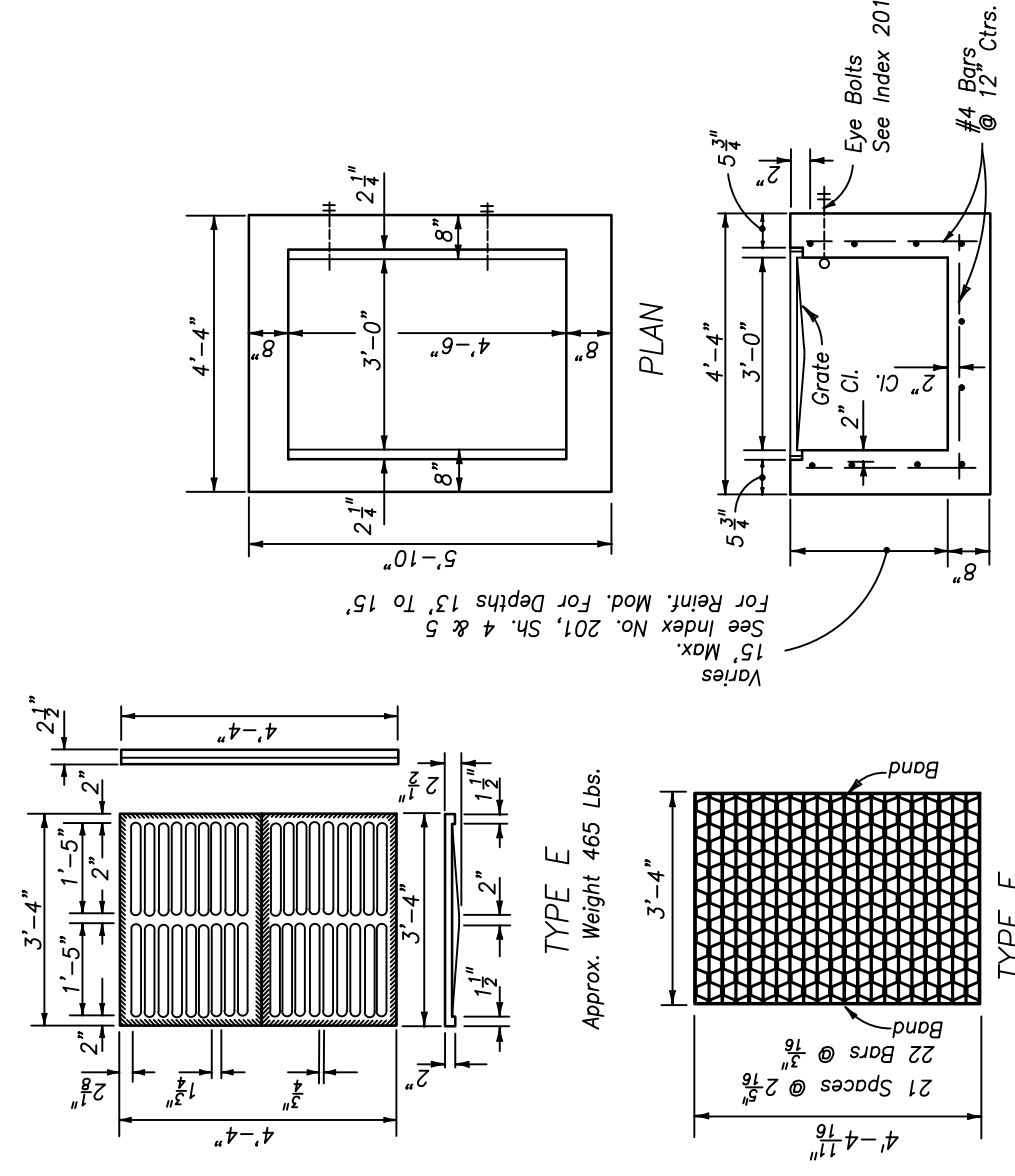

CONCRETE DRIVEWAY PAVEMENT DETAIL
 NOT TO SCALE

6" 3000 PSI CLASS I CONCRETE WITH FIBERMESH
 CONSTRUCTION JOINTS AT 12' ON CENTER

12" TYPE B STABILIZED SUBGRADE COMPACTED TO
 98% OF MODIFIED PROCTOR MAXIMUM DRY DENSITY
 (AASHTO T-180; ASTM D-1557; MINIMUM LBR 40)

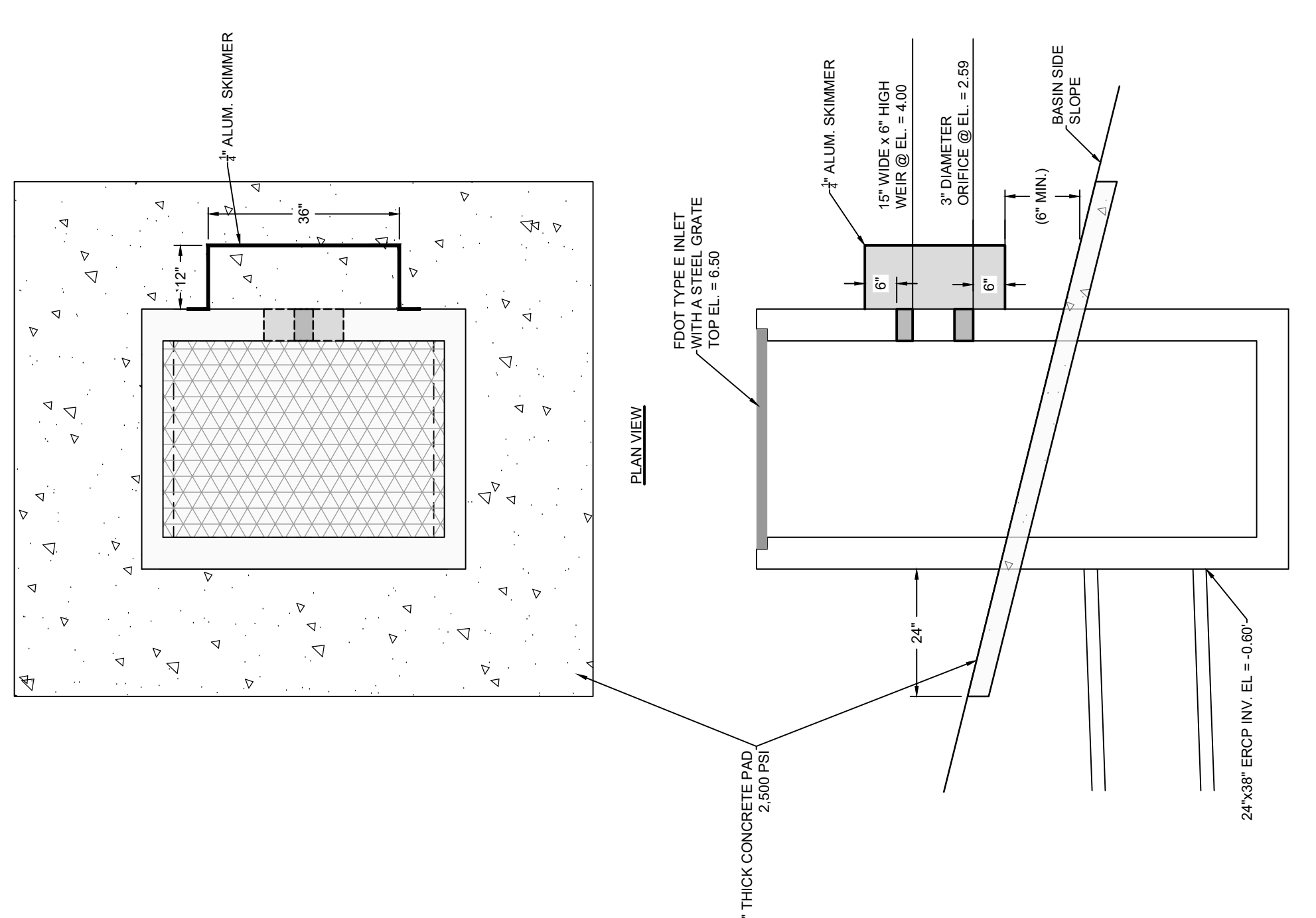

CONSTRUCTION DETAILS
HUGH THOMAS DRIVE IMPROVEMENTS
CALLAWAY, FLORIDA

PANHANDLE ENGINEERING, INC.
 ENVIRONMENTAL ENGINEERS • CIVIL ENGINEERS • LAND PLANNERS
 5405 South Highway 77, Houston, Florida 32244
 (850) 753-9200 Fax (850) 753-0730 www.panhandleengineering.com

REV	DATE	BY	REVISIONS	SCALE	AS NOTED
DESIGNED BY:	CFB				
DRAWN BY:	JAH				
REVIEWED BY:	CFB				
ISSUE DATE:	SEPTEMBER 2019				
ACAD FILE NAME:	26023.dwg				
DATE:					
RELEASED FOR CONSTRUCTION BY:					

**AGREEMENT FOR CONTRACTOR SERVICES
HUGH THOMAS DRIVE IMPROVEMENTS
BID NO: PW2020-01**

This Agreement made as of this ____ day of, January, 2020, by and between the **City of Callaway**, Florida - (the "CITY"), and _____ authorized to do business in the State of Florida (the "CONTRACTOR"), and whose address is _____, Phone: () _____ Fax: () _____.

In consideration of the mutual promises contained herein, the CITY and the CONTRACTOR agree as follows:

ARTICLE 1 - SERVICES

The CONTRACTOR'S responsibility under this Agreement is to furnish, deliver, and construct all materials, labor, and equipment and to perform all operations in accordance with the plans and specifications and as listed in the Bid Form for the **HUGH THOMAS DRIVE IMPROVEMENTS BID NO: PW2020-01**.

Services of the CONTRACTOR shall be under the general direction of the CITY MANAGER, who may designate a person to act as the CITY'S representative (hereinafter "REPRESENTATIVE") during the performance of this Agreement.

The CITY shall furnish to the CONTRACTOR up to four (4) sets of the Contract Documents for execution of the Work. Additional copies of the Contract Documents are available at the cost of reproduction.

ARTICLE 2 – SCHEDULE

The term of this contract shall commence upon written Notice to Proceed by the City. It is projected that all work will be completed within 90 days of the Notice to Proceed.

ARTICLE 3 - PAYMENTS TO CONTRACTOR

- A. The CITY shall pay to the CONTRACTOR for services satisfactorily performed \$_____, which includes all direct charges, indirect charges and reimbursable expenses, if any. The CONTRACTOR will bill the CITY monthly.
- B. The invoices received from the CONTRACTOR pursuant to this Agreement will be reviewed and approved by the City Manager's office, indicating that services have been rendered in conformity with the Agreement, and then will be sent to the Finance Department for payment. The invoice must specify the work performed. Ten percent (10%) of each invoiced amount will be withheld and retained by the CITY until completion of the work to the satisfaction of the CITY.
- C. In order for both parties herein to close their books and records, the CONTRACTOR will clearly state "final invoice" on the CONTRACTOR'S final/last billing to the CITY. This indicates that all services have been performed and all charges and costs have been invoiced to the CITY. Since this account will thereupon be closed, any and other further charges if not properly included on this final invoice shall be waived by the CONTRACTOR.
- D. CONTRACTOR acknowledges that it has reviewed the scope of work, inspected the work site, and does not anticipate having any CONTRACTOR requested change orders.

ARTICLE 4 - TERMINATION

This Agreement may be terminated by the CONTRACTOR on 60 days prior written notice to the CITY in the event of substantial failure by the CITY to perform in accordance with the terms hereof through no fault of the CONTRACTOR. It may also be terminated by the CITY, with or without cause, immediately upon written notice to the CONTRACTOR. Unless the CONTRACTOR is in breach of this Agreement, the CONTRACTOR shall be paid for services rendered to the CITY'S satisfaction through the date of termination. After receipt of a termination notice and except as otherwise directed by the CITY the CONTRACTOR shall:

- A. Stop work on the date and to the extent specified.
- B. Terminate and settle all orders and subcontracts relating to the performance of the terminated work.
- C. Transfer all work in process, completed work, and other material related to the terminated work to the CITY.
- D. Continue and complete all parts of the work that have not been terminated.

ARTICLE 5 - PERSONNEL

The CONTRACTOR represents that it has or will secure at its own expense all necessary personnel required to perform the services under this Agreement. Such personnel shall not be employees of or have any contractual relationship with the CITY.

All of the services required herein under shall be performed by the CONTRACTOR or under its supervision, and all personnel engaged in performing the services shall be fully qualified and, if required, authorized or permitted under State and local law to perform such services.

The CONTRACTOR warrants that all services shall be performed by skilled and competent personnel to the highest professional standards in the field.

ARTICLE 6 - SUBCONTRACTING

The CITY reserves the right to accept the use of a subcontractor or to reject the selection of a particular subcontractor and to inspect all facilities of any subcontractors in order to make a determination as to the capability of the subcontractor to perform properly under this Agreement. The CONTRACTOR is encouraged to seek minority and women business enterprises for participation in subcontracting opportunities.

If a subcontractor fails to perform or make progress, as required by this Agreement, and it is necessary to replace the subcontractor to complete the work in a timely fashion, the CONTRACTOR shall promptly do so, subject to acceptance of the new subcontractor by the CITY.

ARTICLE 7 - FEDERAL AND STATE TAX

The CONTRACTOR shall be responsible for payment of its own FICA and Social Security benefits with respect to this Agreement and the personnel it employs.

ARTICLE 8 – INSURANCE & BONDS

- A. The CONTRACTOR shall not commence work under this Agreement until it has obtained all insurance and bonds required under this paragraph and such insurance has been verified by the CITY.
- B. All insurance policies shall be issued by companies authorized to do business under the laws of the State of Florida.

The CONTRACTOR shall maintain, during the life of this Agreement, comprehensive automobile liability insurance in the amount of \$1,000,000 and \$2,000,000 combined single limit for property damage and bodily injury liability covering claims which may arise from the ownership, use, or maintenance of owned and non-owned automobiles, including rented automobiles, whether such operations be by the CONTRACTOR or by anyone directly or indirectly employed by the CONTRACTOR. CONTRACTOR shall purchase and maintain a policy or policies of commercial general liability insurance satisfactory in all respects to CITY, and casualty and extended coverage insurance. All policies shall be occurrence form policies and shall name CITY as an additional insured, with the premium thereon fully paid by CONTRACTOR on or before their due date. The general liability insurance policy shall afford minimum protection of \$1,000,000 and \$2,000,000 combined single limit coverage for bodily injury.

Required insurance shall be documented in Certificates of Insurance which provide that CITY shall be notified at least 30 days in advance of cancellation, non-renewal or adverse change. New Certificates of Insurance are to be provided to CITY at least 15 days prior to coverage renewals. City of Callaway, Florida is to be named as an additional insured entity.

If requested by CITY, CONTRACTOR shall furnish complete copies of its insurance policies, forms and endorsements.

For commercial general liability coverage, CONTRACTOR shall, at the option of CITY, provide an indication of the amount of claims, payments or reserves chargeable to the aggregate amount of liability coverage.

Receipt of certificates or other documentation of insurance or policies or copies of policies by CITY, or by any of its representatives, which indicate less coverage than required does not constitute a waiver of CONTRACTOR'S obligation to fulfill the insurance requirements herein.

CONTRACTOR shall also purchase and maintain workers compensation insurance for all obligations imposed by law, with employer's liability limits of at least the statutory limit, or provide notarized affidavit of exemption listing relevant statutes. CONTRACTOR shall also purchase any other coverage required by law.

CONTRACTOR'S maintenance of the insurance policies required hereunder shall not limit or otherwise affect its liability hereunder.

- C. In the event that a performance or payment bond is required due to use of grant funds for the project, by City Commission or as otherwise required, the CONTRACTOR shall not commence work under this Agreement until it has obtained the required bonds and provided such bonds to the CITY.

ARTICLE 9 - EXCUSABLE DELAYS

The CONTRACTOR shall not be considered in default by reason of any failure in performance if such failure arises out of causes reasonably beyond the CONTRACTOR'S control and without its fault or negligence. Such causes may include, but are not limited to: acts of God; the City's omissive and commissive failures; natural or public health emergencies; labor disputes; freight embargoes; and severe weather conditions. If failure to perform is caused by the failure of the CONTRACTOR'S subcontractor(s) and is without the fault or negligence of them, the CONTRACTOR shall not be deemed to be in default.

Upon the CONTRACTOR'S request, the CITY shall consider the facts and extent of any failure to perform the work and, if the CONTRACTOR'S failure to perform was without its fault or negligence as determined by the CITY, any affected provision of this Agreement shall be revised accordingly; subject to the CITY'S rights to change, terminate, or stop any or all of the work at anytime.

ARTICLE 10 - LIQUIDATED DAMAGES

Liquidated damages shall be paid to the CITY at the rate of \$200 per day for all work awarded under the contract until the work has been satisfactorily completed as provided by the Contract Documents. Sundays and Legal Holidays shall be excluded in determining days in default.

It is agreed that the amount is the per-diem rate for damage incurred by reason of failure to complete the work. The said amount is hereby agreed upon as the reasonable costs which may be accrued by the CITY after the expiration of the time of completion. It is expressly understood and agreed that this amount is not to be considered in the nature of a penalty, but as liquidated damages which have accrued against the CONTRACTOR. The CITY shall have the right to deduct such damages from any amount due, or that may become due the CONTRACTOR, or the amount of such damages shall be due and collectable from the CONTRACTOR or Surety.

ARTICLE 11 - ARREARS

The CONTRACTOR shall not pledge the CITY'S credit or make it a guarantor of payment or surety for any contract, debt, obligation, judgment, lien, or any form of indebtedness.

ARTICLE 12 - DISCLOSURE AND OWNERSHIP OF DOCUMENTS

The CONTRACTOR shall deliver to the CITY for approval and acceptance, and before being eligible for final payment of any amount due, all documents and materials prepared by and for the CITY under this Agreement.

All written and oral information not in the public domain or not previously known, and all information and data obtained, developed, or supplied by the CITY or at its expense will be kept confidential by the CONTRACTOR and will not be disclosed to any other party, directly or indirectly, without the CITY'S prior written consent.

Such information and data shall be and will remain the CITY'S property and may be reproduced and reused at the discretion of the CITY.

All products generated by the CONTRACTOR for the CITY become the property of the CITY. The CITY may require submission of any electronic file version of reports, data, maps, or other submission of documentation produced for or as a result of this project in addition to paper documents.

The CITY and the CONTRACTOR shall comply with the provisions of the Florida Public Records Law.

PUBLIC RECORDS LAW. CONTRACTOR acknowledges that it is familiar with the provisions of the Public Records Law of the State of Florida.

CONTRACTOR agrees to comply with Chapter 119, Florida Statutes, and specifically per Florida Statute 119.0701, CONTRACTOR agrees to keep and maintain public records that would be required by the City of Callaway in order to perform the services provided for in this Agreement; CONTRACTOR agrees to provide public access to any required public records in the same manner as a public agency; CONTRACTOR agrees to protect exempt or confidential records from disclosure; CONTRACTOR agrees to meet public records retention requirement; and CONTRACTOR agrees that at the end of term of this Agreement, to transfer all public records to the City of Callaway and destroy any duplicate exempt or confidential public records.

All products generated by the CONTRACTOR for the CITY become the property of the CITY. The CITY may require submission of any electronic file version of reports, data, maps or other submission of documentation produced for or as a result of this Bid/Proposal in addition to paper documents.

Further, in accordance with the Public Records Laws of the State of Florida, Section 119.0701, (2013), Contractor must:

- A. Keep and maintain public records that ordinarily and necessarily would be required by the public agency in order to perform the service.
- B. Provide the public with access to public records on the same terms and conditions that the public agency would provide the records and at a cost that does not exceed the cost provided in this chapter or as otherwise provided by law.
- C. Ensure that public records that are exempt or confidential and exempt from public records are not disclosed except as authorized by law.
- D. Meet all requirements for retaining public records and transfer, at no cost, to the public agency all public records in possession of the contractor upon termination of the contract and destroy any duplicate public records that are exempt or confidential and exempt from public record disclosure requirements. All records stored electronically must be provided to the public agency in a format that is compatible with the information technology systems of the public agency.
- E. If a contractor does not comply with a public records request, the public agency shall enforce the contract provision in accordance with the contract.

All covenants, agreements, representations, and warranties made herein, or otherwise made in writing by any party pursuant hereto shall survive the execution and delivery of this Agreement and the consummation of the transactions contemplated hereby.

If the CONTRACTOR has questions regarding the application of Chapter 119, Florida Statutes, to the CONTRACTOR'S duty to provide public records relating to this contract, contact the custodian of public records, Janice Peters, City Clerk, at 850-215-6694, by email at jpeters@cityofcallaway.com, or via mail, at 6601 E. Hwy. 22, Callaway, FL 32404.

ARTICLE 13 - INDEPENDENT CONTRACTOR RELATIONSHIP

The CONTRACTOR is, and shall be, in the performance of all work services and activities under this Agreement, an independent contractor, and not an employee, agent, or servant of the CITY. All persons engaged in any of the work or services performed pursuant to this Agreement shall at all times, and in all places, be subject to the CONTRACTOR'S sole direction, supervision, and control. The CONTRACTOR shall exercise control over the means and manner in which it and its employees perform the work, and in all respects the CONTRACTOR'S relationship and the relationship of its employees to the CITY shall be that of an independent contractor and not as employees or agents of the CITY.

The CONTRACTOR does not have the power or authority to bind the CITY in any promise, agreement or representation.

The CONTRACTOR shall hold the CITY, its officers, agents and employees harmless and free from any loss, damage or expense arising out of any occurrence relating to this Agreement or its performance and shall indemnify the CITY, its officers, agents and employees, customers, and successors against any damage or claim of any type arising from the negligent or intentional acts or omission of the CONTRACTOR.

ARTICLE 14 - CONTRACT ASSIGNMENT

The CONTRACTOR shall not sublet, sell, transfer, assign or otherwise dispose of the CONTRACT or any portion thereof, or of his right, title, or interest therein, without written consent of the CITY. The CONTRACTOR shall complete the work contemplated by the terms and conditions of this Agreement in an amount equivalent to at least 50 percent (50%) of the dollar value of work to be performed under this Contract utilizing its own business or corporate entity, so that no single labor, material man, or subcontractor shall be permitted to perform more than 50% of the work contemplated by this Contract.

ARTICLE 15 - AMENDMENT

None of the provisions, terms and conditions contained in this Agreement may be added to, modified, superseded or otherwise altered, except by a written instrument executed by the parties hereto.

ARTICLE 16 - ENFORCEMENT COSTS

If any legal action or other proceeding is brought for the enforcement of this Agreement, or because of an alleged dispute, breach, default, or misrepresentation in connection with any provision, the successful or prevailing party or parties shall be entitled to recover reasonable attorney's fees, court costs and all expenses even if not taxable as court costs (including, without limitation, all such fees, costs and expenses incident to appeals), incurred in that action or proceeding, in addition to any other relief to which such party or parties may be entitled.

ARTICLE 17 - AUTHORITY TO PRACTICE

The CONTRACTOR hereby represents and warrants that it has and will continue to maintain all licenses and approvals required to conduct its business, and that it will at all times conduct its business activities in a reputable manner.

ARTICLE 18 - SEVERABILITY

If any term or provision on this Agreement, or the application thereof to any person or circumstances shall, to any extent, be held invalid or unenforceable, the remainder of this Agreement, or the application of such terms or provisions to persons or circumstances other than those as to which it is held invalid or

unenforceable, shall not be affected, and every other term and provision of this Agreement shall be deemed valid and enforceable to the extent permitted by law.

ARTICLE 19 - CITY'S REPRESENTATIVE AND AUTHORITY

The person designated by the CITY MANAGER shall serve as the CITY'S REPRESENTATIVE and shall decide questions which may arise as to quality and acceptability of materials furnished and work performed, and shall interpret the intent of the Contract Documents with reasonable promptness.

The REPRESENTATIVE will not be responsible for the construction means, controls, techniques, sequences, procedures, or construction safety.

The REPRESENTATIVE may assign Project Inspector(s) who shall serve to assist the REPRESENTATIVE in determining if the work performed and the materials used meet the Contract requirements. The Project Inspector shall be authorized to issue Field Orders. The Project Inspector shall be authorized to stop all or any portion of the work if in his opinion the work is not proceeding according to the requirements of the plans and specifications.

ARTICLE 20 - MODIFICATION

The CITY reserves the right to make changes in the work, including alterations, reductions therein or additions thereto. Upon receipt by the CONTRACTOR of the CITY'S notification of a contemplated change, the CONTRACTOR shall (1) if requested by CITY, provide an estimate for the increase or decrease in cost due to the contemplated change, (2) notify the CITY of any estimated change in the completion date, and (3) advise the CITY in writing if the contemplated change shall affect the CONTRACTOR'S ability to meet the completion dates or schedules of this Agreement.

If the CITY so instructs in writing, the CONTRACTOR shall suspend work on that portion of the work affected by a contemplated change, pending the CITY'S decision to proceed with the change.

If the CITY elects to make the change, the CITY shall issue a contract amendment or change order and the CONTRACTOR shall not commence work on any such change until such written amendment or change order has been issued and signed by each of the parties.

ARTICLE 21 - CONTRACT DOCUMENTS

The other documents which comprise the entire Agreement are attached hereto, made a part hereof and consist of the following:

- A. Advertisement for Bids,
- B. Special Instructions and Conditions,
- C. General Instructions and Conditions,
- D. Minimum Technical Specifications,
- E. Bid Forms
 - Bid Certification Form
 - Drug-Free Workplace Certification
 - Public Entity Crimes Statement
 - Proprietary/Confidential Information Form
 - Certification Regarding Debarment
 - Trench Safety Compliance Certification Form
 - Anti-Collusion Clause Form

- G. Addendums (if any),
- H. Performance & Payments Bonds (if required),
- I. Change Orders (if any).

In the event of a conflict between the terms of the above documents and the terms of this Agreement, the terms of this Agreement shall prevail.

There are no contract documents other than those listed above and there are no promises or understandings other than those stated herein.

ARTICLE 22 - VENUE

All applicable laws, regulations and ordinances of the State of Florida, Bay County and the City of Callaway will apply to consideration and award of any Bid/Proposal and the performance of the bidder/proposal pursuant thereto, and shall be governed by the laws of the State of Florida both as to intention and performance. The venue for any action arising from the award or subsequent performance shall lie exclusively in the Circuit Court of Bay County, Florida, or the United States District Court for the Northern District of Florida, as applicable.

ARTICLE 23 - NOTICE

All notices required in this Agreement shall be sent by certified mail, return receipt requested, and if sent to the CITY shall be mailed to:

City of Callaway
 6601 East Hwy. 22
 Callaway, Florida 32404
 Attention: Janice L. Peters, City Clerk
 Phone: (850) 215-6694
 Fax: (850) 871-2224
 Email: jpeters@cityofcallaway.com

With a copy to: Kevin D. Obos, Esq. City Attorney
 Hand Arendall Harrison Sale
 P.O. Drawer 1579
 Panama City, FL 32402
 Phone: (850) 769-3434
 Fax: (850) 769-6121

and if sent to the CONTRACTOR shall be mailed to:

Either party may change its address noted above by giving written notice to the other party in accordance with the requirements of the Section.

This Agreement is entered into as of the day and year first written above and is executed in at least two original copies of which one is to be delivered to the CONTRACTOR, and one to the CITY CLERK for filing in the official records.

CITY CLERK

CITY OF CALLAWAY, FLORIDA

Attest: _____
Janice L. Peters, MMC
City Clerk

By: _____
Keith E. Cook, City Manager

Contractor Witnesses:
(2 REQUIRED)

Contractor:

Witness: _____
Name

Signature

Business Name
By: _____
Signature

Witness: _____
Name

Signature

Print Name and Title

APPROVED AS TO FORM FOR THE RELIANCE OF THE
CITY OF CALLAWAY ONLY:

KEVIN D. OBOS, CITY ATTORNEY
HAND ARENDALL HARRISON SALE



PROPOSAL CHECKLIST
CITY OF CALLAWAY
HUGH THOMAS DRIVE IMPROVEMENTS
BID NO: PW2020-01

**FORMS/ITEMS TO BE RETURNED
WITH YOUR PROPOSAL!**

The following forms are to be completed/signed by the Proposer and submitted to the City:

1. Bid/RFP Certification Form(s),
2. One (1) unbound set of bid packet with original notarized signatures, plus five (5) copies
3. Bid Bond or Cashier's Check/Certified Check in the amount of 5% of bid,
4. Proof of Insurance in amounts required by the City with the City listed as Certificate Holder and Additionally Insured (See Special Instructions & Conditions),
5. State of Florida or Bay County Contractor License or Certificate
6. Public Entity Crime Statement, [Complete items 1 and 6; notarized signature required]
7. Drug-Free Workplace Certification Form, [Complete Part I; notarized signature, or sign Part II]
8. List of Subcontractors with names of directors or owners, addresses, telephone numbers, and email address (if applicable),
9. List of references for similar type work with contact information.
10. Proprietary/Confidential Information Form
11. Certification Regarding Debarment
12. Anti-Collusion Clause Form

Note: Incomplete Bid/Proposal submissions may not be accepted/considered. **Do not modify the forms!** Any additional information you desire to present may be included as an attachment.

Reminder: Submit requested number of copies! (See Special Instructions and Conditions)

BID/RFP CERTIFICATION FORM
CITY OF CALLAWAY
HUGH THOMAS DRIVE IMPROVEMENTS
BID NO: PW2020-01

PROPOSERS CERTIFICATION TO THE CITY OF CALLAWAY:

1. The undersigned warrants that: (A) This Proposal is submitted in response to, and is in compliance with, all terms and conditions applicable thereto as set forth in the Advertisement, Instructions to Proposers, General Instructions and Conditions, Special Instructions and Conditions, Bid/RFP Certification Forms, the Minimum Technical Specifications, Addendum, Exhibits, Agreement, Bonds, and Insurance Requirements, each of which has been carefully examined, (B) Proposer or Proposer's representative has made such investigation as is necessary to determine the character and extent of the work and their capability to perform the work, and (C) agrees that if the Proposal is accepted by the City, Proposer will provide the necessary labor, materials, machinery, equipment, tools or apparatus, and perform all the work or services required to complete the assignment and/or contract within the time specified according to the requirements of the City as herein and hereinafter set forth, and (D) he/she is authorized to legally execute binding contracts for and on behalf of the Proposer.
2. Please check one:
 - Proposer declares that the only person, persons, company, or parties interested in this Proposal are named in the Proposal.
 - Proposer, or one or more of Proposer's officers, principals, or any owner of more than 5% in or of proposer, or members of their immediate families: (A) have a financial interest in another company, project, or property that could benefit financially from this proposed project; and/or (B) another individual or business will be compensated by (or on behalf of proposer) if Proposer is selected by the City for the requested services. (Attach a detailed explanation for either.)
3. Bid Bond - If the Proposal is accepted by the City, it will become a binding contract on both parties. If a Bid Bond or Cashier's Check/Certified Check is required, it shall be submitted with the Proposal. If the undersigned shall fail to deliver or perform, or if applicable, execute a Contract as stated herein, then the City may, at its option, determine that the undersigned has abandoned the Award/Contract, and thereupon such Bid and/or Award shall be null and void, and any Cashier's Check/Certified Check or Bond accompanying this Bid shall be forfeited to and become the property of the City, and the full amount of said check, or if a Bid Bond, the full amount of such bond, shall be paid to the City as partial liquidated damages; otherwise, any Bond or Cashier's Check/Certified Check accompanying this Bid shall be returned to the undersigned within 30 calendar days from the date of Award, or if provisions for a Notice to Proceed are included, from the date of the Notice to Proceed.
4. Vendor proposes and agrees to provide all materials, services or equipment required for the City of Callaway **HUGH THOMAS DRIVE IMPROVEMENTS BID NO: PW2020-01**, for the Total Sum(s) as follows (*totals must match attached breakdown of costs for each Lift Station*):
 _____ Dollars (\$_____).
5. Number of days from date of the Notice to Proceed that will be required for the final completion of all work as described herein.

 (Maximum 90 Calendar Days)
6. The City reserves the right to accept any or all prices itemized in any combination that best serves the interests of the City. The City further reserves the right to accept or reject any of the components of this Proposal, including alternates.
7. BIDDER HEREBY ACKNOWLEDGES RECEIPT OF THE FOLLOWING ADDENDUMS: _____

Name of Bidder: _____

Business structure: () Corporation, () Partnership, () Individual, () Other: _____

If a Partnership: _____

Name(s) of Partner(s): _____

If a Corporation: _____

Incorporated in State of: _____ Date of Incorporation: _____

Business Address: _____

City: _____ State _____ Zip _____

Telephone Number: () _____ Fax () _____

Submitted By: _____

(Print)

Title: _____

Signature: _____

ATTEST: _____

Secretary

By: _____

Print Name

Affix Corporate Seal
(If Corporation)

State of Florida
County of

The foregoing instrument was acknowledged before me this ___ day of _____, 20 __, by _____, who is personally known to me or who presented _____ as identification, and who (did) (did not) take an oath.

[Signature of Notary Public]

[Printed, typed or stamped name of Notary Public]

NOTE: BIDS MAY BE REJECTED IF ALL DOCUMENTS ARE NOT COMPLETE AND EXECUTED, AND THE NUMBER OF COPIES SPECIFIED/REQUESTED OF EACH ARE NOT SUBMITTED WITH THE BID.

**SWORN STATEMENT PURSUANT TO SECTION 287.133(3)(a),
FLORIDA STATUTES, ON PUBLIC ENTITY CRIMES**

THIS FORM MUST BE SIGNED AND SWORN TO IN THE PRESENCE OF A NOTARY PUBLIC OR OTHER OFFICIAL AUTHORIZED TO ADMINISTER OATHS.

1. This sworn statement is submitted to City of Callaway, Florida, a Municipal Corporation, 6601 East Hwy. 22, Callaway, Florida 32404 by _____
[print individual's name and title]
for _____ whose business
[print name of entity submitting sworn statement]
address is _____
_____ and (if applicable) it's Federal Identification Number
(FEIN) is _____ (If the entity has no FEIN, include the Social Security
Number of the individual signing this sworn statement _____)
2. I understand that a "public entity crime" as defined in Paragraph 287.133(1)(g), **Florida Statutes**, means a violation of any state or federal law by a person with respect to and directly related to the transaction of business with any public entity or with an agency or political subdivision of any other state or of the United States, including, but not limited to, any bid or contract for goods or services to be provided to any public entity or any agency or political subdivision of any other state or of the United States and involving antitrust, fraud, theft, bribery, collusion, racketeering, conspiracy, or material misrepresentation.
3. I understand that "convicted" or "conviction" as defined in Paragraph 287.133(1)(b), **Florida Statutes**, means a finding of guilt or a conviction of a public entity crime, with or without an adjudication of guilt, in any federal or state trial court of record relating to charges brought by indictment or information after July 1, 1989, as a result of a jury verdict, non-jury trial, or entry of a plea of guilty or nolo contendere.
4. I understand that an "affiliate" as defined in Paragraph 287.133(1)(a), **Florida Statutes**, means:
 1. A predecessor or successor of a person convicted of a public entity crime; or
 2. An entity under the control of any natural person who is active in the management of the entity and who has been convicted of a public entity crime. The term "affiliate" includes those officers, directors, executives, partners, shareholders, employees, members, and agents who are active in the management of an affiliate. The ownership by one person of shares constituting a controlling interest in another person, or a pooling of equipment or income among persons when not for fair market value under an arm's length agreement, shall be a prima facie case that one person controls another person. A person who knowingly enters into a joint venture with a person who has been convicted of a public entity crime in Florida during the preceding 36 months shall be considered an affiliate.
5. I understand that a "person" as defined in Paragraph 287.133(1)(e), **Florida Statutes**, means any natural person or entity organized under the laws of any state or of the United States with the legal power to enter into a binding contract and which bids or applies to bid on contracts for the provision of goods or services let by a public entity, or which otherwise transacts or applies to transact business with a public entity. The term "person" includes those officers, directors, executives, partners, shareholders, employees, members, and agents who are active in management of an entity.

6. Based on information and belief, the statement which I have marked below is true in relation to the entity submitting this sworn statement. **[Indicate which statement applies.]**

_____ Neither the entity submitting this sworn statement, nor any of its officers, directors, executives, partners, shareholders, employees, members, or agents who are active in the management of the entity, nor any affiliate of the entity has been charged with and convicted of a public entity crime subsequent to July, 1 1989.

_____ The entity submitting this sworn statement, or one or more of its officers, directors, executives, partners, shareholders, employees, members, or agents who are active in the management of the entity, or an affiliate of the entity has been charged with and convicted of a public entity crime subsequent to July 1, 1989.

_____ The entity submitting this sworn statement, or one or more of its officers, directors, executives, partners, shareholders, employees, members, or agents who are active in the management of the entity, or an affiliate of the entity has been charged with and convicted of a public entity crime subsequent to July 1, 1989. However, there has been a subsequent proceeding before a Hearing Officer of the State of Florida, Division of Administrative Hearings and the Final Order entered by the Hearing Officer determined that it was not in the public interest to place the entity submitting this sworn statement on the convicted vendor list. **[attach a copy of the final order]**

I UNDERSTAND THAT THE SUBMISSION OF THIS FORM TO THE CONTRACTING OFFICER FOR THE PUBLIC ENTITY IDENTIFIED IN PARAGRAPH 1 (ONE) ABOVE IS FOR THAT PUBLIC ENTITY ONLY AND, THAT THIS FORM IS VALID THROUGH DECEMBER 31 OF THE CALENDAR YEAR IN WHICH IT IS FILED. I ALSO UNDERSTAND THAT I AM REQUIRED TO INFORM THE PUBLIC ENTITY PRIOR TO ENTERING INTO A CONTRACT IN EXCESS OF THE THRESHOLD AMOUNT PROVIDED IN SECTION 287.017, FLORIDA STATUTES FOR CATEGORY TWO OF ANY CHANGE IN THE INFORMATION CONTAINED IN THIS FORM.

[signature]

PW2020-01

[Reference: RFP Number]

Sworn to and subscribed before me this ___ day of _____, 20___. Personally known _____ or produced identification _____

[Type of identification]

Notary Public - State of _____

My Commission expires: _____

[Signature of Notary]

[Printed, typed or stamped commissioned name of Notary Public]

CITY OF CALLAWAY
DRUG-FREE WORKPLACE CERTIFICATION

Please complete Part I or Part II as applicable.

In order to be given preference in the award process for having implemented a drug-free workplace program prior to the Bid/Proposal submission date, the Bidder/Proposer is requested to certify that as part of their drug-free workplace program, they have:

1. Published a statement notifying employees that the unlawful manufacture, distribution, dispensing, possession, or use of a controlled substance is prohibited in the workplace and specified the actions that will be taken against employees for violations of such prohibition.
2. Informed employees about the dangers of drug abuse in the workplace, the business policy of maintaining a drug-free workplace, any available drug counseling, rehabilitation, and employee assistance programs, and the penalties that may be imposed upon employees for drug abuse violations.
3. Given each employee engaged in providing the commodities or contractual services that are under bid a copy of the statement specified in Subsection 1.
4. In the statement specified in Subsection 1, notified the employees that, as a condition of working on the commodities or contractual services that are under bid, the employee will abide by the terms of the statement and will notify the employer of any conviction of, or plea of guilty or nolo contendere to, any violation of Chapter 893 or of any controlled substance law of the United States or any state, for a violation occurring in the workplace no later than five (5) days after such conviction.
5. Imposed a sanction on, or required the satisfactory participation in a drug abuse assistance or rehabilitation program if such is available in the employee's community by any employee who is so convicted.
6. Made a good faith effort to continue to maintain a drug-free workplace through implementation of this section.

Part I - PROGRAM IMPLEMENTED

I certify that I/we have established a drug-free workplace program meeting the foregoing minimum requirements.

[Printed, typed name]

[Signature]

State of Florida

County of _____

The foregoing instrument was acknowledged before me this ____ day of _____, 20__, by _____, who is personally known to me or who presented _____ as identification, and who (did) (did not) take an oath.

[Signature of Notary Public]

[Printed, typed or stamped name of Notary Public]

[Commission Number of Notary Public]

Part II - PROGRAM NOT IMPLEMENTED

A program meeting the above stated requirements has not been established or has not been fully implemented prior to Bid/Proposal closing date, and therefore I/we are not eligible for certification as a drug-free workplace.

[Signature]

[Date]

**PROPRIETARY/CONFIDENTIAL INFORMATION
HUGH THOMAS DRIVE IMPROVEMENTS
RFP NO. PW2020-01**

Name of Firm of Bidder/Vendor: _____

Trade secrets or proprietary information submitted by a Vendor shall not be subject to public disclosure under the Freedom of Information Act; however, the Vendor must invoke such protections provided by state law, in writing, either before or at the time the data or other material is submitted. The written notice must specifically identify the data or materials to be protected, including the section of the proposal in which it is contained, as well as the page number(s), and state the reasons why protection is necessary. The proprietary or trade secret material submitted must be identified by some distinct method such as highlighting or underlining and must indicate only the specific words, figures, or paragraphs that constitute a trade secret or proprietary information. In addition, a summary of proprietary information provided shall be submitted on this form. The designation of an entire proposal document, line item prices, and/or total proposal prices as proprietary or trade secrets is not acceptable. If, after being given reasonable time, the Vendor refuses to withdraw such a classification designation, the proposal will be rejected.

SECTION/TITLE	PAGE NUMBER(S)	REASON(S) FOR WITHHOLDING FROM DISCLOSURE

Check this box if there are none.
This document must be completed and returned with proposal.

**CERTIFICATION REGARDING DEBARMENT, SUSPENSION, INELIGIBILITY
VOLUNTARY EXCLUSION FORM**

Contractor Covered Transactions

- (1) The prospective contractor of the Recipient, _____, certifies, by submission of this document, that neither it nor its principals are presently debarred, suspended, proposed for debarment, declared ineligible or voluntarily excluded from participation in this transaction by any Federal department or agency.
- (2) Where the Recipient's contractor is unable to certify to the above statement, the prospective contractor shall attach an explanation to this form.

CONTRACTOR:

By _____
Signature

Recipient's Name

Name and Title

Division Contract Number

Street Address

FEMA Project Number

City, State, Zip

Date

CERTIFICATE OF COMPLIANCE WITH THE FLORIDA TRENCH SAFETY ACT

Bidder acknowledges sole responsibility for complying with the Florida Trench Safety Act (Act) under Section 653.60, Florida Statutes and Occupational Safety and Health Administration's excavation safety standard 29 CFR 1926.650 (Subpart P as amended). Bidder further acknowledges that included in the various items of the proposal and in the Total Lump Sum Bid are costs for complying with the Florida Trench Safety Act (90-96, Laws of Florida) effective October 1, 1990. The bidder further identifies the costs to be summarized below:

	Trench Safety Method (Description)	Units of Measure (LF, SY)	Unit (Quantity)	Extended Cost	Unit Extended Cost
A.					
B.					
C.					
D.					
				Total: \$	_____

Failure to complete the above may result in the bid being declared non-responsive. The costs indicated above are provided to comply with the Act and shall not constitute grounds for any additional compensation to that listed for the separate line items of the Bid Form.

Bidder: _____

License No.: _____

Date: _____

Authorized Signature & Title

ANTI-COLLUSION CLAUSE FORM

Firm certifies that their response is made without prior understanding, agreement, or connection with any Corporation, Firm or person submitting a response for the same services and is in all respects fair and without collusion or fraud.

Name of Firm: _____

Authorized Signature: _____

Printed Name: _____

Title: _____

Date: _____