

Pittsburg State University is seeking proposals for renovations to the PSU Cadaver Lab as specified below.

A. Summary of Scope:

	Description
<u>DEMOLITION</u>	<ol style="list-style-type: none"> 1. Remove existing casework and countertop. 2. Remove existing sink, faucet, and glass piping 3. Remove existing coat rack
<u>REPAIR & REPLACEMENT</u>	<ol style="list-style-type: none"> 1. Reconnect new sinks and fixtures to existing supply and waste lines. 2. Patch/repair all surfaces to match existing adjacent surfaces. 3. Install ceiling curtain tracks, curtain, connectors, and build out any necessary framing, per manufacturer’s specifications. 4. Patch resinous floor to match existing. 5. Install phenolic lockers, including cast in place concrete and rough carpentry for base, per manufacturer’s specifications. 6. Install modular phenolic resin casework, mobile modular phenolic resin casework, shelving, and accessory items as specified. 7. Install epoxy resin countertops and sinks, stainless steel countertops and sinks, service fittings and outlets, laboratory waste fittings as specified.
<u>DEADLINE</u>	<p>All work must be completed by EOB 12/1/2023.</p>

Detailed plan drawings available as Attachment A.

Detailed specifications of scope available as Attachment B.

B. Quote Requirements:

I. Quote Requirements

- a. Quotes must itemize cost for removal, installation, and materials.
- b. Quotes must include estimated shipping & delivery timeframes.
- c. Quotes must include all fees that will be invoiced to PSU.
- d. Quotes must be received by PSU before the deadline specified in this RFP. Failure to submit quotes to PSU on time will result in disqualification.
- e. Submissions are preferred by email to Sean Burke – swburke@pittstate.edu. Submissions by standard mail are allowed, if vendor chooses to mail submission, please send to:
 - Purchasing Office
 - 1701 S Broadway Street
 - 110 Russ Hall
 - Pittsburg, Ks 66762

* Please note that no exceptions will be made for late delivery of mailed submissions.

C. Terms and Conditions

* Terms and conditions are available after Attachment A & Attachment B.

D. General Provisions Signature

Tax Clearance Certification: Bid submittals of \$25,000 or more shall include a copy of a Tax Clearance Certification. Tax Clearances may be obtained from the Kansas Dept. of Revenue (KDOR): <http://www.ksrevenue.org/taxclearance.html>

W9 Form: Vendors who are new to PSU should submit a copy of their W9 with bid response. The form can be downloaded at www.irs.gov/pub/irs-pdf/fw9.pdf

DA-146a Contractual Provisions: The bidder agrees to accept the provisions of form DA-146a, Contractual Provisions Attachment which is incorporated into all contracts with the State <http://www.da.ks.gov/purch/DA-146a.pdf>

NEW MATERIALS, SUPPLIES, OR EQUIPMENT: Unless otherwise specified, all materials, supplies or equipment offered by a vendor shall be new, and unused in any regard. All materials, supplies and equipment shall be first class in all respects. Seconds or flawed items will not be acceptable. All materials, supplies or equipment shall be suitable for their intended purpose and, unless otherwise specified, fully assembled and ready for use on delivery.

PUBLIC WORKS BOND: A Public Works Bond is not required for Projects with a contract price below \$100,000.00.

The Contractor shall file with the Director of Purchasing a Public Works Bond as required by K.S.A. 60-1111 in an amount equal to one hundred percent (100%) of price bid and shall be filed with the Clerk of the District Court in the County where the project is being constructed.

The guaranty shall be returned to the Contractor upon the completion of this contract subject to total or partial forfeiture for failure to perform adequately the terms of this contract. If damages exceed the amount of the guaranty, the State may seek additional damages. *Added by addendum on 7/26/2023

ACCEPTANCE OR REJECTION: PSU reserves the right to accept or reject any or all bids or part of a bid; to waive any informalities or technicalities; clarify any ambiguities in bids; and unless otherwise specified, to accept any item in the bid.

PAYMENT: Payment will be made upon receipt of shipment by PSU.

FREIGHT COST INFORMATION: FOB Destination, Freight Prepaid, and Allowed.

The undersigned certifies that he does not have any substantial conflict of interest sufficient to influence the bidding process on this bid. A conflict of substantial interest is one which a reasonable person would think would compromise the open competitive bid process.

Legal Name of Person, Firm or Corporation:
Payment Terms:
Telephone Number:
E-mail Address:
Signature: _____
Date: _____

DEMOLITION NOTES

- GENERAL CONTRACTOR SHALL VERIFY ALL EXISTING CONDITIONS, AND DIMENSIONS PRIOR TO INSTALLATION OF ANY NEW CONSTRUCTION. ALL DISCREPANCIES SHALL BE REPORTED TO THE ARCHITECT IMMEDIATELY.
- DEMOLITION IS TO TAKE PLACE AS REQUIRED FOR THE INSTALLATION OF NEW SYSTEMS (ELECTRICAL, PLUMBING, AND MECHANICAL, ETC.). GC IS RESPONSIBLE FOR PATCHING OR REBUILDING PORTIONS OF EXISTING CONSTRUCTION TO REMAIN, AFTER NEW SYSTEMS ARE IN PLACE.
- G.C. IS RESPONSIBLE FOR PATCHING ALL AREAS WHERE DEMOLISHED CONSTRUCTION ADJOINS EXISTING CONSTRUCTION TO REMAIN.
- NOTE THAT THE DEMOLITION PLAN DOES NOT NECESSARILY LIST EVERY ITEM OF DEMOLITION AND THAT THE CONTRACTOR IS RESPONSIBLE FOR ADDITIONAL DEMOLITION AS REQUIRED FOR THE NEW CONSTRUCTION.
- GENERAL CONTRACTOR SHALL BE AWARE THAT THIS FACILITY WILL REMAIN OPERATIONAL DURING CONSTRUCTION. OCCUPANT ACCESS TO, FROM AND WITHIN NON-CONSTRUCTION AREAS SHALL BE SAFE AND SECURE.
- ASBESTOS ABATEMENT, IF REQUIRED, WILL BE COMPLETED FOR AREAS REQUIRING DEMOLITION. ABATEMENT WORK SHALL BE COMPLETED IN AFFECTED AREAS. ABATEMENT WILL BE OVERSEEN BY THE OWNER.
- G.C. IS RESPONSIBLE FOR PROTECTING AREAS ADJACENT TO NEW ACTIVITIES.
- THE OWNER RESERVES THE RIGHT TO RETAIN ANY OR ALL REMOVED MATERIALS, FIXTURES, EQUIPMENT, ETC. ALL UNWANTED ITEMS SHALL BE REMOVED FROM THE PREMISES. ITEMS DESIGNATED FOR RETENTION BY THE OWNER SHALL BE REMOVED IN A MANNER TO MINIMIZE DAMAGE AND STORED ON SITE PER OWNERS DIRECTION.

DEMOLITION LEGEND

- ITEM TO BE DEMOLISHED OR REMOVED

DEMOLITION PLAN NOTES

- REMOVE EXISTING CASEWORK AND COUNTERTOP
- REMOVE EXISTING SINK, FAUCET AND GLASS PIPING
- REMOVE EXISTING COAT RACK

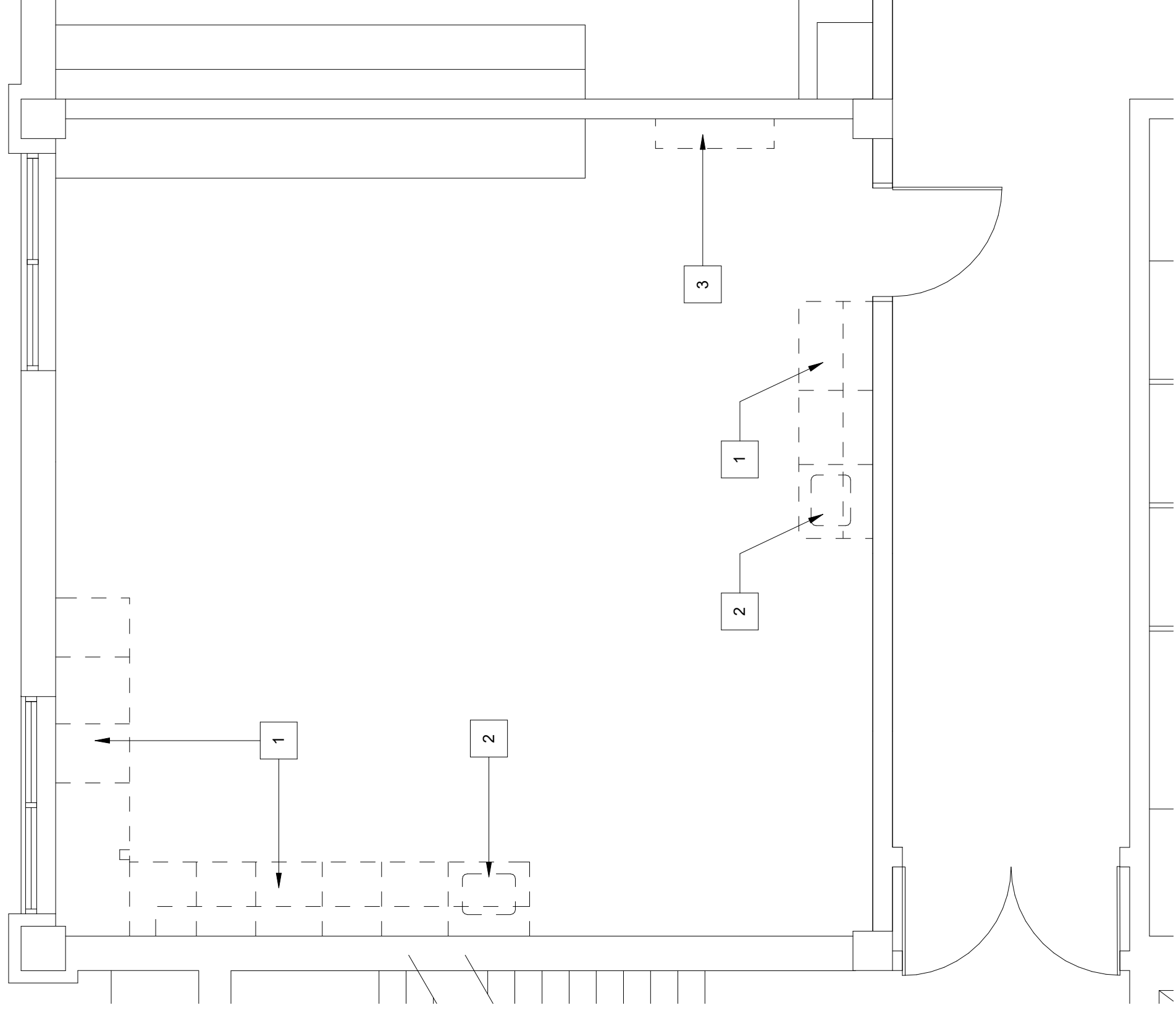

SECOND FLOOR DEMOLITION PLAN



SECOND FLOOR ARCHITECTURAL PLAN



GENERAL NOTES

- CONTRACTOR TO VISIT SITE, VERIFY ALL EXISTING CONDITIONS AND NOTIFY THE ARCHITECT OF ANY INITIAL DISCREPANCIES AS WELL AS ANY DISCREPANCIES ENCOUNTERED DURING DEMOLITION.
- DIMENSIONS ARE TO FACE OF NEW METAL STUD, FACE OF BRICK, OR FACE OF CONCRETE.
- CONTRACTOR SHALL COORDINATE DEMOLITION OPENINGS WITH ARCHITECTS DIMENSIONED PLANS.
- EXISTING FURNITURE, OFFICE EQUIPMENT, ETC. WILL BE RELOCATED BY OWNER AS REQUIRED FOR CONSTRUCTION TO OCCUR. PROVIDE TEMPORARY PROTECTION FOR ITEMS AND EXISTING CONSTRUCTION TO REMAIN IN PLACE.
- CONTRACTOR SHALL PROVIDE FIRE RETARDANT TREATED WOOD BLOCKING IN OPENINGS AS REQUIRED FOR UNFINISHED OPENINGS AND CASEWORK. COORDINATE WITH ALL SUPPLIERS FOR FINAL LOCATIONS.
- PATCH/REPAIR ALL SURFACES, TO MATCH EXISTING ADJACENT SURFACES. AT DEMOLISHED MECHANICAL AND ELECTRICAL EQUIPMENT. COORDINATE WITH MEP DRAWINGS FOR LOCATIONS.
- ALL MOVEABLE EQUIPMENT, FURNITURE, ETC. (SHOWN DASHED) TO BE PROVIDED BY OWNER.
- GENERAL CONTRACTOR SHALL BE RESPONSIBLE TO CONFIRM THAT ALL OPENINGS, DEMOLITION CUTS TO BE COMPLETED AS NOTED IN THIS PLAN. ALL OPENINGS TO BE CORRECTLY INSTALLED AND FINISHED TO MATCH EXISTING CONDITIONS. CORRECTLY. THIS SHOULD INCLUDE, BUT NOT NECESSARILY BE LIMITED TO THE FOLLOWING: DOORS, FRAMES & OPENINGS, TOILET FIXTURES AND ACCESSORIES, SHOWERS, ETC.
- RECONNECT NEW SINKS AND FIXTURES TO EXISTING SUPPLY AND WASTE LINES PER PSU CAMPUS PLUMBING STANDARDS. WASTE LINES ARE TO BE OF SCH 40 CHEMICAL WASTE PIPING.

PLAN NOTES

- CEILING CURTAIN
- PATCH RESINOUS FLOOR TO MATCH EXISTING

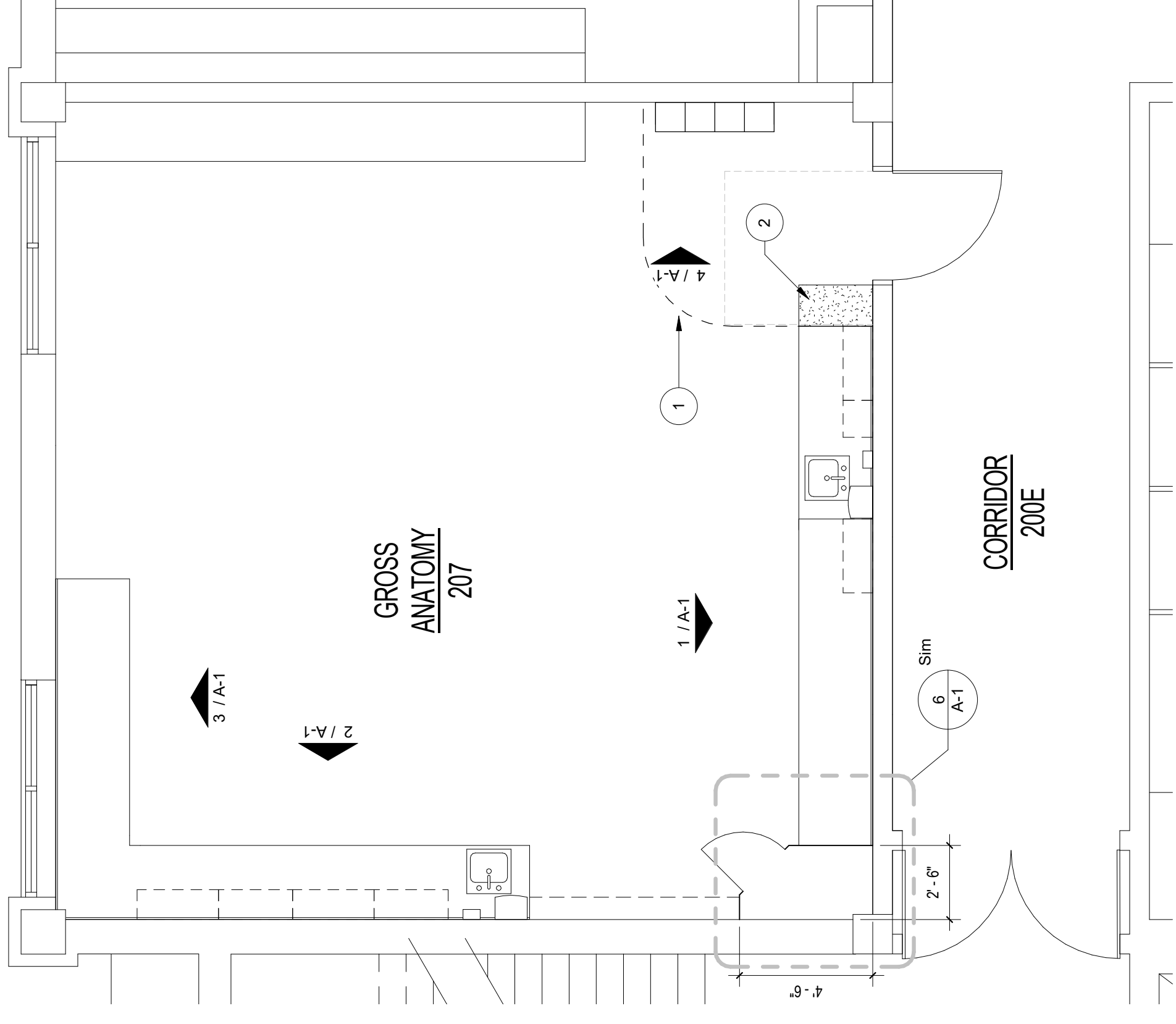

INTERIOR ELEVATION

1 1/4" = 1'-0"

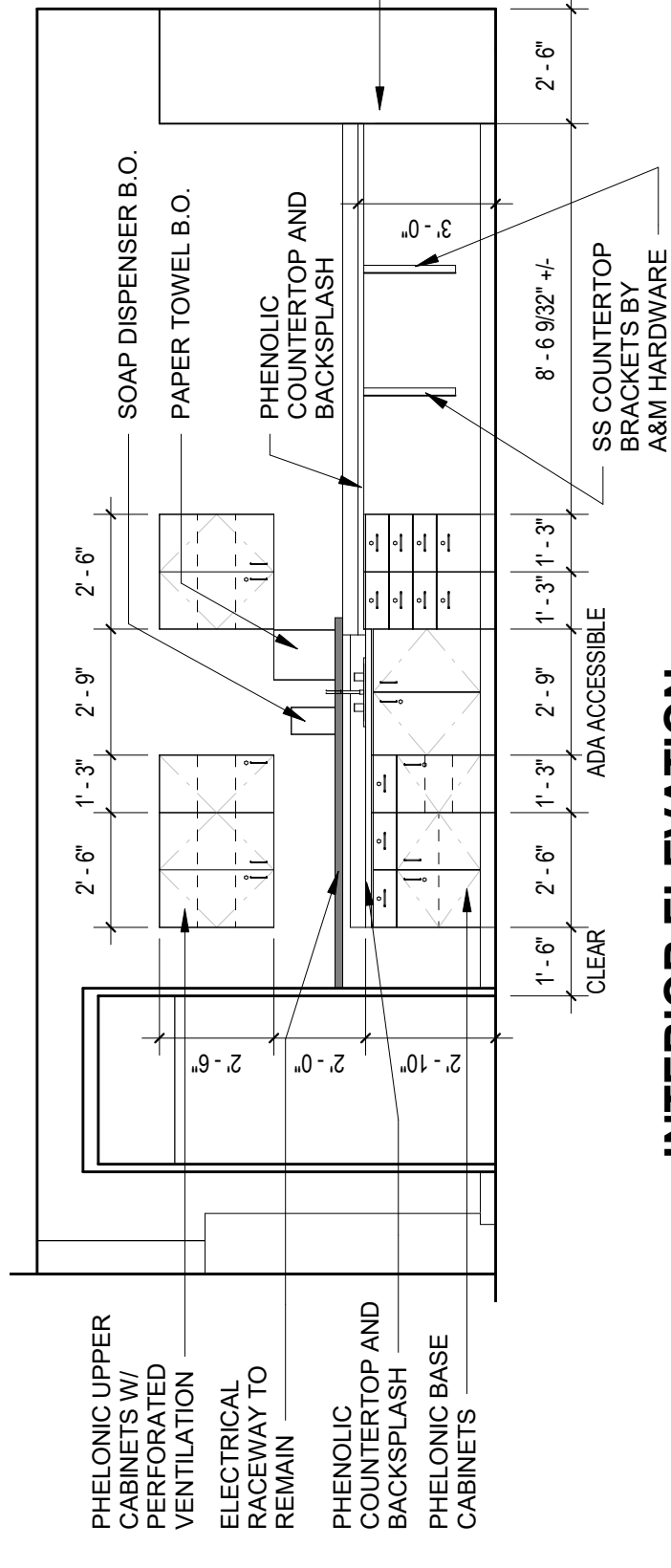

INTERIOR ELEVATION

2 1/4" = 1'-0"

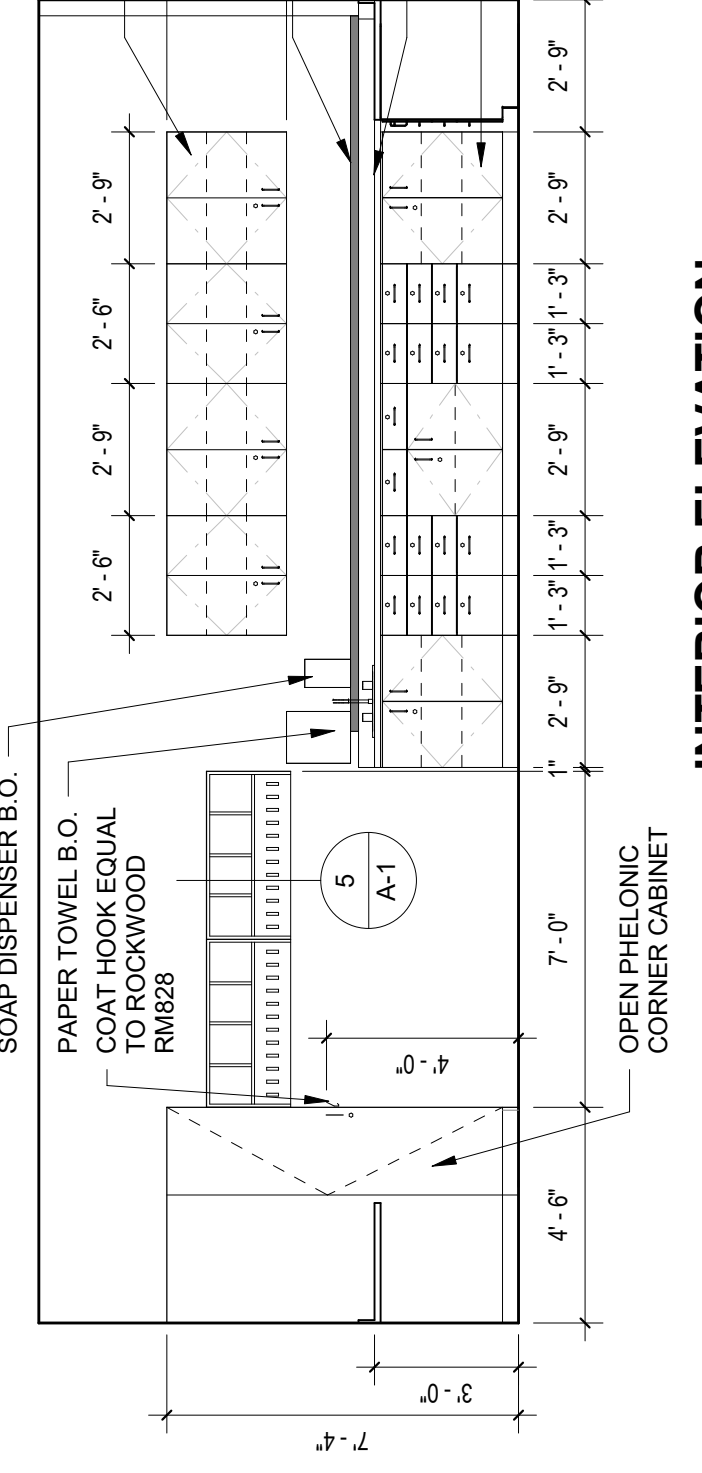

INTERIOR ELEVATION

3 1/4" = 1'-0"

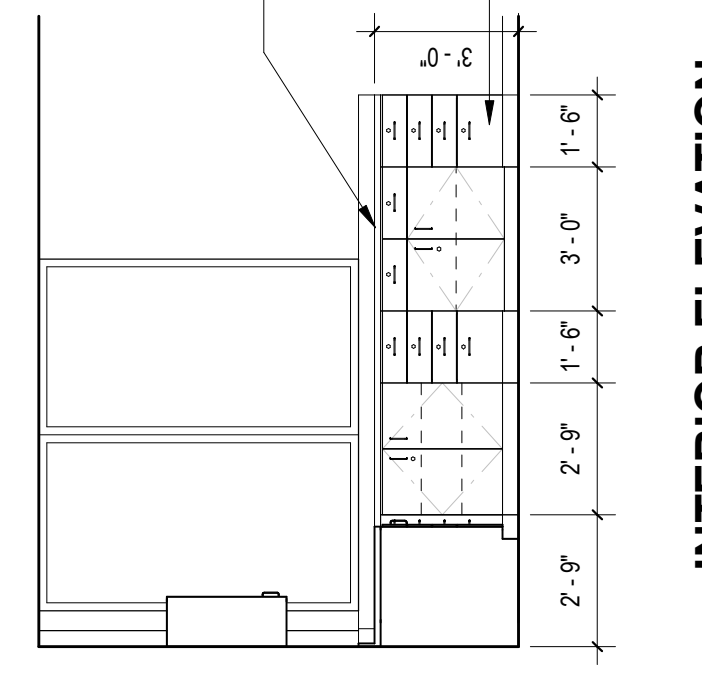

INTERIOR ELEVATION

4 1/4" = 1'-0"

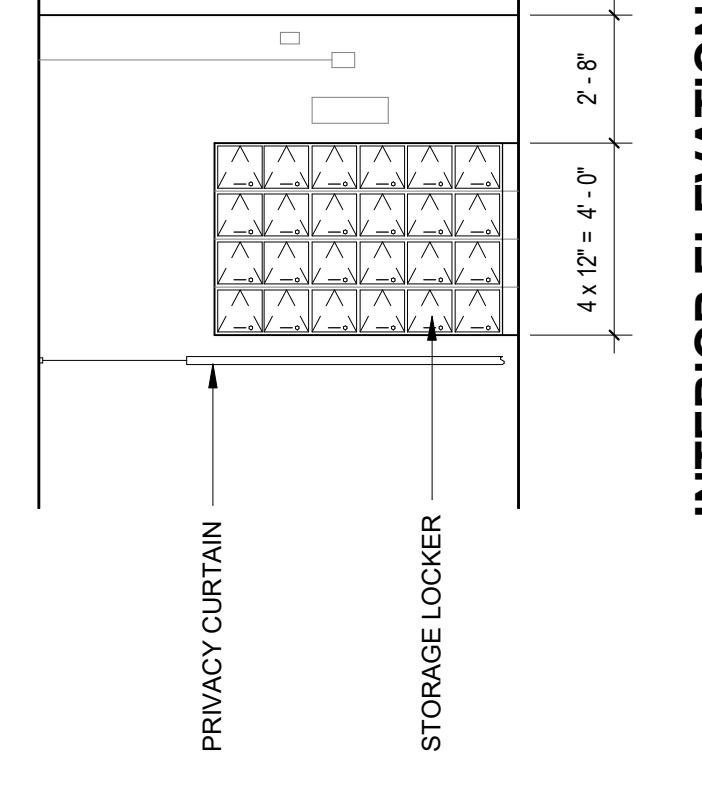

INTERIOR ELEVATION

5 1" = 1'-0"

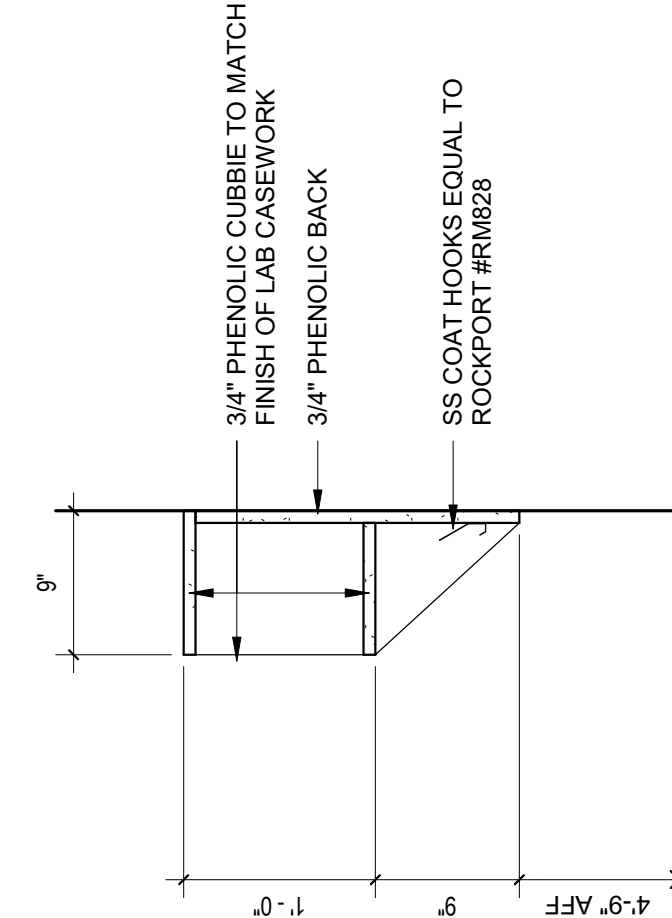

COAT HOOK DETAIL

5 1" = 1'-0"

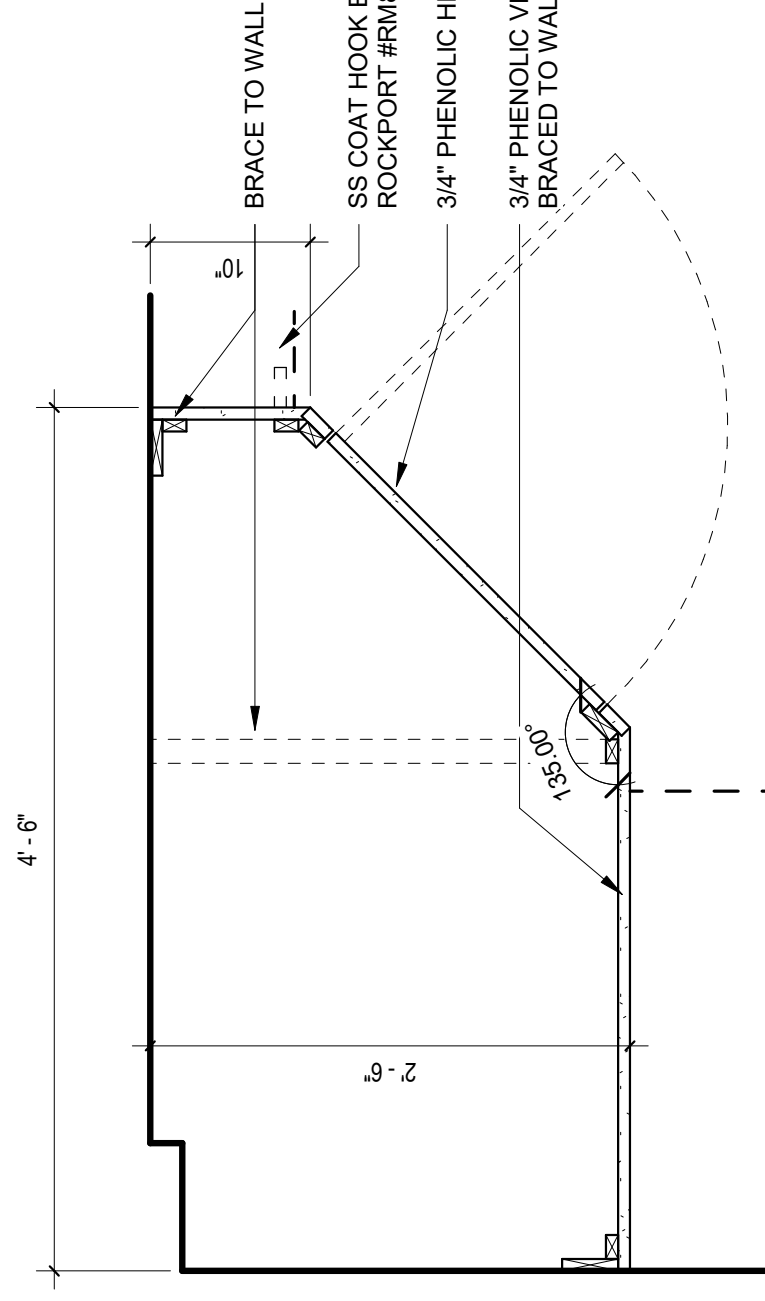

CLOSET PLAN

6 1" = 1'-0"



alloy architecture.com
162 S. ROCK ISLAND, SUITE 200
TOPEKA, KANSAS 66603
P: 316.434.1111

PROJECT NUMBER
23138

The drawing and all information herein is the exclusive property of Alloy Architecture and is not to be reproduced, copied, or used without the express written consent of Alloy Architecture. All designs, drawings, and arrangements appearing herein constitute the confidential and unpublished work of the Architect.

Copyright © 2023
Alloy Architecture

Department of Administration
Office of Facilities & Property Management
Design, Construction & Compliance
700 Harrison, Suite 1200
Topeka, Kansas 66603
Phone 785-296-8899

PITTSBURG STATE UNIVERSITY
CADAVER LAB RENOVATION
HECKERT WELLS HALL
Pittsburg, Kansas
BUILDING NUMBER 38500-0005
DRAWN BY: Jeff Sherrard
DATE: 05.05.2023

ARCHITECTURAL
FIRST FLOOR PLAN

A-1

100% Review

PSU Cadaver Lab Renovation
Alloy Project No. 23141

**SECTION 10.19.00
CUBICLE CURTAINS AND TRACK SYSTEMS**

PART 1 GENERAL

1.01 SECTION INCLUDES

- A. Curtain tracks and curtain carriers.
- B. Cubicle curtains.
- C. Extent of curtains and track is indicated on Drawings and schedules.

1.02 RELATED REQUIREMENTS

- A. Section 06.10.0 – Rough Carpentry: Concealed supports for accessories, including in wall framing and plates, above ceiling framing.
- B. Section 09.29.00 – Gypsum Board: Concealed supports for accessories, including in wall framing and plates, above ceiling framing.

1.03 PERFORMANCE REQUIREMENTS

- A. Curtains: Provide curtain fabrics with the following characteristics:
 - 1. Fabrics are launderable to a temperature of not less than 160 deg F (71 deg C).
 - 2. Fabrics are flame resistant and are identical to those that have passed NFPA 701 when tested by a testing and inspecting agency acceptable to authorities having jurisdiction.

1.04 SUBMITTALS

- A. Product Data: Submit copies of manufacturer's detailed technical data for materials, fabrication and installation of cubicle curtain tracks and curtains specified herein. Include catalog cuts of fittings, anchors, fastenings and accessories.
- B. Shop Drawings: Show layout and types of cubicles, sizes of curtains, number of carriers, and conditions requiring accessories.
- C. Samples for Verification: Full-size units of each type of the following products:
 - 1. Curtain Fabric: 12-inch square swatch or larger Sample as required to show complete pattern repeat, from dye lot used for the Work, with specified treatments applied. Mark top and face of material.
 - 2. Mesh Top: Not less than 4 inches square.
 - 3. Curtain Track: Not less than 4 inches long.
 - 4. Curtain Carrier: Full-size unit.
- D. Cubicle Schedule: Use same room designations as indicated on Drawings.
- E. Product Certificates: Signed by manufacturers of tracks and curtains certifying that products furnished comply with requirements.
- F. Maintenance Data: For tracks and curtains to include in maintenance manuals specified in Division 1.

1.05 PROJECT CONDITIONS

- A. Environmental Limitations: Do not install cubicles until spaces are enclosed and weatherproof, wet work in spaces is complete and dry, work above ceilings is complete, and ambient temperature and humidity conditions are maintained at the levels indicated for Project when occupied for its intended use.
- B. Field Measurements: Where cubicles are indicated to fit to other construction, verify dimensions of other construction by field measurements before fabrication and indicate measurements on Shop Drawings. Coordinate fabrication schedule with construction progress to avoid delaying the Work.

PART 2 PRODUCTS

**CUBICLE CURTAINS AND TRACK SYSTEMS
10.19.00 - 1 of 3**

2.01 MANUFACTURERS

- A. Manufacturers: One manufacturer's product is specified as a standard. Subject to compliance with requirements, manufacturers offering products which may be incorporated in the work include the following or approved equal:
1. A. R. Nelson, 3555 Scarlet Oak Blvd., St. Louis, MO, 63122, 800-377-6625

2.02 CURTAIN TRACKS

- A. Extruded-Aluminum Track No. 1200CT: 1-3/8 inches wide by 3/4-inch-high aluminum track.
1. Curved Track: Factory fabricated 12-inch radius bends.
 2. Finish: Satin anodized.
- B. Track Accessories: End caps, connectors, end gates, coupling and joining sleeves, wall brackets, ceiling flanges, and other accessories.
1. End Stop: Removable.
- C. No. 12 Curtain Carriers: Two nylon rollers, nylon axle and tangle free nylon swivel stem with chrome-plated steel hook.
- D. No. 20 Breakaway Carrier: Three-piece nylon wheels, body and hook.

2.03 CURTAINS

- A. Curtain Fabric: Cubicle manufacturer's standard, as follows:
1. Fiber Content: 100 percent polyester, inherently and permanently flame resistant.
 2. Products: Subject to compliance with requirements, provide the following:
 - a. Nelson Cubicle Curtains
 - 1) Pattern: As selected by Architect from manufacturer's full range of available fabrics.
 - 2) Color: As selected by Architect from manufacturer's full range of available colors.
- B. Mesh Top: Anti-microbial white nylon mesh with 1/2" diagonal openings.
- C. Curtain Grommets: Two-piece, rolled-edge, rustproof, nickel-plated brass; spaced not more than 6 inches o.c.; machined into top hem.

2.04 CURTAIN FABRICATION

- A. Fabricate curtains to comply with the following requirements:
1. Width: Equal to track length from which curtain is hung plus 10 percent added fullness, but not less than 12 inches added fullness.
 2. Length: Equal to floor-to-ceiling height, with 20-inch mesh top, and minus distance above finished floor at bottom as follows:
 1. Cubicle Curtains: 14 inches.
 3. Top Hem: Not less than 1 inch and not more than 1-1/2 inches wide, triple thickness, reinforced with integral web, and double lock stitched.
 4. Mesh Top: Top hem not less than 1 inch and not more than 1-1/2 inches wide, triple thickness, reinforced with integral web, and double lock stitched. Double lock stitch bottom of mesh directly to 1/2-inch triple thickness, top hem of curtain fabric.
 5. Bottom Hem: 1 inch double thickness and single lock stitched.
 6. Side Hems: Not less than 1/2 inch and not more than 1-1/4 inches wide, with double turned edges, and single lock stitched.
 7. Vertical Seams: Not less than 1/2 inch wide, double turned and double stitched.

PART 3 EXECUTION

3.01 INSTALLATION

- A. General: Install tracks level and plumb, according to manufacturer's written instructions. Provide track fabricated from one continuous length up to 16 feet.
 - 1. Curtain Track Mounting: Surface
- B. Surface Track Mounting: Fasten surface-mounted tracks at intervals of not less than 24 inches. Fasten support at each splice and tangent point of each corner. Center fasteners in track to ensure unencumbered carrier operation. Attach track to ceiling as follows:
 - 1. Mechanically fasten to suspended ceiling grid with screws.
- C. Track Accessories: Install end caps, connectors, end gates, coupling and joining sleeves, and other accessories as required for a secure and operational installation.
- D. Curtain Carriers: Provide curtain carriers adequate for 6-inch spacing along the full length of the curtain.
- E. Curtains: Hang curtains on each curtain track.
- F. Mounting Locations: Indicated on Drawings.

3.02 DEMONSTRATION

- A. Train Owner's maintenance personnel to adjust, operate, and maintain safety- loading units.
 - 1. Train Owner's maintenance personnel on procedures and schedules for changing curtains and maintaining cubicles.

3.03 PROTECTION

- A. Protect installed track openings with non-residue adhesive tape to prevent debris from ceiling finishing operations from impeding carrier operation

3.04 ADJUSTING AND CLEANING

- A. Adjust curtain and track for proper operation and verify that mechanisms function smoothly. Replace damaged or defective items.
- B. Clean and polish all exposed surfaces after removing temporary labels and protective coatings.

END OF SECTION 10.19.00

**SECTION 10.51.29
PHENOLIC LOCKERS**

PART 1 GENERAL

1.01 SECTION INCLUDES

- A. This Section includes metal lockers and related equipment as indicated on drawings. Types of products in this section include the following:
 - 1. Solid phenolic lockers

1.02 RELATED REQUIREMENTS

- A. Section 03.30.00 – Cast-in-Place Concrete: Concrete base construction.
- B. Section 06.10.00 – Rough Carpentry: Wood base construction.

1.03 SUBMITTALS

- A. Product Data: For each type of product.
 - 1. Include construction details, material descriptions, dimensions of individual components and profiles, and finishes for each type of locker.
- B. Shop Drawings: For phenolic lockers.
 - 1. Include plans, elevations, sections, and attachment details.
 - 2. Show locations and sizes of cutouts and holes for items installed in lockers.
 - 3. Show locker fillers, trim, base, sloping tops, and accessories.
 - 4. Show locker identification system and numbering sequence.
- C. Samples for Initial Selection: For each type of locker.
 - 1. Include Samples of hardware and accessories involving material and color selection.
- D. Samples for Verification: For the following products, in manufacturer's standard sizes unless otherwise indicated:
 - 1. Phenolic panels, not less than 3 by 3 inches, for each type, color, pattern, and surface finish.
 - 2. Exposed locker hardware and accessories, one unit for each type and finish.

1.05 CLOSEOUT SUBMITTALS

- A. Maintenance Data: For adjusting, repairing, and replacing locker doors and latching mechanisms.
 - 1. Include manufacturer's written instructions for periodic cleaning and maintenance of each component.

1.06 DELIVERY, STORAGE AND HANDLING

- A. Deliver and store lockers in manufacturer's original unopened packaging until ready for installation.
- B. Do not deliver lockers until painting and similar operations that could damage lockers have been completed in installation areas. If lockers must be stored in other-than-installation areas, store only in areas where environmental conditions are the same as those in final installation location, and comply with requirements specified in "Field Conditions" Article.

1.07 FIELD CONDITIONS

- A. Environmental Limitations: Do not deliver or install lockers until building is enclosed, wet-work is complete, and HVAC system is operating and maintaining temperature between 60 and 90 deg F and relative humidity between 30-60 percent during remainder of the construction period.
- B. Field Measurements: Where lockers are indicated to fit to other construction, verify dimensions of other construction by field measurements before fabrication, and indicate measurements on Shop Drawings.
- C. Established Dimensions: Where lockers are indicated to fit to other construction, establish dimensions for areas where lockers are to fit. Provide allowance for trimming at site, and coordinate construction to ensure that actual dimensions correspond to established

dimensions.

1.08 WARRANTY

- A. Special Warranty: Manufacturer agrees to replace phenolic locker components that fail in materials or workmanship within specified warranty period.
 - 1. Warranty Period: 10 years from date of Substantial Completion.

PART 2 PRODUCTS

2.01 PERFORMANCE REQUIREMENTS

- A. Accessibility Standard: For lockers indicated to be accessible, comply with applicable provisions in the USDOJ's "2010 ADA Standards for Accessible Design"
- B. Accessibility Requirements: Comply with requirements of the ADA and of authorities having jurisdiction.

2.02 PHENOLIC LOCKERS

- A. Basis-of-Design Product: Subject to compliance with requirements, provide ASI Storage Solutions; an ASI Group company; Phenolic Traditional Collection Lockers or comparable product by one of the following:
 - 1. Bobrick Washroom Equipment, Inc.
 - 2. Bradley Corporation.
- B. Construction Style: Manufacturer's standard means of factory assembly with machined joints, pins, and tamper-resistant mechanical fasteners.
- C. Configuration: Z-Style 2 tier.
- D. Body: Fabricated from solid phenolic panels.
 - 1. Side Panels: 1/2 inch thick.
 - 2. Back Panel: 1/2 inch thick.
 - 3. Top Panel: 1/2 inch thick.
 - 4. Bottom Panel: 1/2 inch thick.
 - 5. Shelves: 1/2 inch thick.
- E. Doors: 1/2-inch thick, solid phenolic panel, fabricated to full width of locker; frameless with perimeter ventilation.
- F. End Panels: 1/2-inch thick, solid phenolic panel matching doors.
- G. Continuous Flat Top Panels: 1/2-inch thick, solid phenolic panel matching doors.
- H. Base: 1-inch thick by 4-inch high, solid HDPE plastic; black color.
- I. Color: As selected by Architect from manufacturer's full range.
 - 1. Edge (Core) Color: Black.

2.03 MATERIALS

- A. Phenolic Panels: Solid phenolic with [selected high-pressure melamine matte finish as an integral part of core material. Laminated surfaces are unacceptable.

2.04 HARDWARE

- A. Recessed Door Handle and Latch: Manufacturer's standard; black HDPE plastic cup with integral door pull, recessed so locking device does not protrude beyond door face; pry and vandal resistant.
 - 1. Single-Point Latching: Nonmoving latch hook with steel padlock hasp projecting through recessed cup.
 - a. Latch Hook: Equip each door with manufacturer's standard latch hook, mounted midway up each door.
- B. Locks: Combination padlocks.
- C. Hinges: Manufacturer's standard; steel with black, powder-coated finish, to allow door to open 120 degrees.
- D. Identification Plates: Manufacturer's standard; etched, embossed, or stamped aluminum plates, with black numbers at least 1/2 inch high.
- E. Hooks: Manufacturer's standard; ball-pointed, zinc-plated steel hooks.

- F. Coat Rods: Manufacturer's standard.

2.05 ACCESSORIES

- A. Fasteners: Zinc- or nickel-plated steel, slotless-type, exposed bolt heads; with self-locking nuts or lock washers for nuts on moving parts.
- B. Anchors: Material, type, and size required for secure anchorage to each substrate.
 - 1. Provide nonferrous-metal or hot-dip galvanized anchors and inserts on inside face of exterior walls, for corrosion resistance.
 - 2. Provide toothed-steel or lead expansion sleeves for drilled-in-place anchors.

2.06 FABRICATION

- A. Fabricate and supply factory preassembled lockers, complete with hardware and accessories.
- B. Fabricate each locker with shelves; a single door and frame; and a single top, bottom, and back; and with common intermediate uprights separating compartments.
 - 1. Fabricate lockers to dimensions, profiles, and details indicated.
- C. Fabricate lockers square, rigid, without warp, and with finished faces flat and free of scratches, and chips. Factory machine components to suit attachments. Make joints tight and true.
 - 1. Fabricate lockers using manufacturer's standard mortise and tenon construction.
 - 2. Provide tops and end panels as required to complete installation as indicated on Drawings.
- D. Accessible Lockers: Fabricate as follows:
 - 1. Locate bottom shelf minimum 15 inches above finished floor.
 - 2. Where hooks, coat rods, or additional shelves are provided, locate maximum 48 inches above finished floor.
- E. Complete fabrication, including assembly, finishing, and hardware application, to maximum extent possible, before shipment to Project site. Disassemble components only as necessary for shipment and installation. Where necessary for fitting at site, provide ample allowance for scribing, trimming, and fitting.
 - 1. Trial fit assemblies at fabrication shop unable to be shipped completely assembled. Install dowels, screws, bolted connectors, and other fastening devices removable after trial fitting. Verify that parts fit as intended, and check measurements of assemblies against field measurements indicated on Shop Drawings before disassembling for shipment.
 - 2. Use only locker manufacturer's brackets, nuts, bolts, screws, and other anchoring devices for assembly.
- F. Shop cut openings, to maximum extent possible, to receive hardware, electrical work, and similar items. Locate openings accurately and use templates or roughing-in diagrams to produce accurately sized and shaped openings.

PART 3 EXECUTION

3.01 EXAMINATION

- A. Examine walls and floors or support bases, with Installer present, for compliance with requirements for installation tolerances and other conditions affecting performance of the Work.
- B. Verify that furring is attached to concrete and masonry walls receiving lockers.
- C. Proceed with installation only after unsatisfactory conditions have been corrected.

3.02 PREPARATION

- A. Condition lockers to average prevailing humidity conditions in installation areas before installation.
- B. Before installing lockers, examine factory-fabricated work for completeness and complete work as required, including removal of packing.
- C. Thoroughly clean surfaces prior to installation.

3.03 INSTALLATION

- A. Install lockers in accordance with manufacturer's written instructions.
- B. Install lockers level, plumb, and true; use concealed shims.
- C. Connect groups of lockers together with manufacturer's standard stainless steel, theft-proof fasteners, through predrilled holes in locker interior. Fit lockers accurately together to form flush, tight, hairline joints.
- D. Install lockers without distortion for doors and drawers to fit and align with openings. Adjust hardware to center doors and drawers in openings and provide unencumbered operation. Complete installation of hardware and accessory items as indicated.
 - 1. Installation Tolerance: Maximum 1/8- in 96-inch sag, bow, or other variation from a straight line. Shim as required with concealed shims.
- E. Locker Anchorage: Fasten lockers through back, near top and bottom, at ends with anchoring devices furnished, and spaced not more than 16 inches o.c.
- F. Scribe and cut corner and filler panels to fit adjoining work using fasteners concealed where practical. Repair damaged finish at cuts.

3.04 ADJUSTING

- A. Clean, lubricate, and adjust hardware. Adjust doors to operate easily without binding.

3.05 PROTECTION

- A. Protect lockers from damage, abuse, dust, dirt, stain, or paint. Do not permit use during construction.
- B. Clean exposed surfaces of lockers and hardware.
- C. Touch up marred finishes to factory-finished appearance, or replace unrestorable lockers. Use only materials and procedures recommended or furnished by locker manufacturer.

END OF SECTION 10.15.19

**SECTION 12.35.53
LABORATORY CASEWORK**

PART 1 GENERAL

1.01 SECTION INCLUDES

- A. Modular Phenolic Resin Casework
- B. Mobile Modular Phenolic Resin Casework
- C. Shelving
- D. Accessory items as specified herein.

1.02 RELATED SECTIONS

- A. Division 09 Section 65 13, "Resilient Base and Accessories"
- B. Division 12 Section 36 00, "Countertops"

1.03 REFERENCE STANDARDS

- A. AWI: Quality Standards, Second Edition
- B. ISO 9001:2015 – Quality Management International Standards Organization (ISO)
- C. FSC: Forest Stewardship Council
- D. ADA, ATBCB, ADAAG: Americans with Disabilities Act Accessibility Guidelines Americans with Disabilities Act

1.04 SUBMITTALS

- A. Product Data: Drawings shall include data and details for construction of the laboratory casework as well as information regarding the name, quantity, type and construction of materials (such as hardware, etc.), that will be used to complete the project.
- B. Shop Drawings:
 - 1. The laboratory casework manufacturer shall furnish shop drawings illustrating the layout and placement of all laboratory casework and fume hoods as well as any products included in this section.
 - 2. Indicate the type and location of all service fittings and associated supply connections.
 - 3. Preparation instructions and recommendations.
 - 4. Storage and handling requirements and recommendations.
 - 5. Installation methods.
- C. Selection Samples: Submit the following:
 - 1. Samples for Selection: Manufacturer's standard sample collection.
 - 2. One unit of each type of exposed hardware.
 - 3. One (1) 24" wide, full-height base cabinet: Construction to consist of one (1) drawer, one (1) door, with adjustable full depth shelf and related hardware (pulls, hinges, drawer slides, etc.).
 - 4. One 36" wide x 36" high wall cabinet: Construction to consist of two adjustable shelves as well as related hardware and doors.
- D. Quality Assurance/Control
 - 1. Design Data: Manufacturer shall submit design criteria which are in compliance with the project specifications.
 - 2. Manufacturers' Instructions: Provide manufacturer's instructions for installation and maintenance of all products provided and installed within this section.

1.05 DELIVERY, STORAGE AND HANDLING

- A. Packaging, Shipping, Handling and Unloading:
 - 1. Packaging: Products shall have packaging adequate enough to protect finished surfaces from soiling or damage during shipping, delivery and installation.

2. Shipping: Casework delivery shall only take place after painting, utility rough-ins and related activities are completed that could otherwise damage, soil or deteriorate casework in installation areas.
 3. Handling and Unloading: Care, such as the use of proper moving equipment, experienced movers, etc., shall be used at all times to avoid damaging the casework. Until installation takes place, any wrapping, insulation or other method of protection applied to products from the factory will be left in place to avoid accidental damage.
- B. Acceptance at Site: Casework will not be delivered or installed until the conditions specified under Part 3.2 of this document have been met. Products delivered to sites that are not enclosed and/or improperly conditioned will not be warranted against warping or damage due to unsatisfactory conditions.
- C. Storage: Casework shall be stored in the area of installation. If, prior to installation, it is necessary for casework to be temporarily stored in an area other than the installation area, the environmental conditions shall meet the environmental requirements specified under the Project Site Conditions article of this Specification. An operational HVAC system that maintains temperature and humidity at occupancy levels must be in place.
- D. Waste Management and Disposal: The supplier of the laboratory casework is responsible for removing any waste or refuse resulting from the installation of, or work pertaining to laboratory casework; thereby leaving the project site clean and free of debris. Trash container(s) are to be provided by others.

1.06 QUALITY ASSURANCE

- A. Manufacturer Qualifications: The following list of information will be provided to the Architect at least ten (10) days prior to the bid opening:
1. List of manufacturing facilities.
 2. A list of ten (10) installations of comparable stature completed by their workforce within the past 5 years
 3. Construction details depicting the materials, sizes and methods of construction
 4. Independent laboratory test reports that include information, fume hoods and table top finish and performance
 5. SEFA member in good standing

1.07 WARRANTY

- A. Furnish a written warranty that work performed under this Section shall remain free from defects as to materials and workmanship for a period of one (1) year from date of shipment. Defects in materials and workmanship that may develop within this time are to be replaced without cost or expense to the Owner. Damage caused by vandalism or improper storage of products as mentioned in Section 3.2 shall not be included within warranty.

Defects include, but are not limited to:

1. Cracked, or delamination.
 2. Slippage, shift, or failure of attachment to wall, floor, or ceiling.
 3. Structural failure.
 4. Warping or unloaded deflection of components.
 5. Failure of hardware
- B. The warranty with respect to products of another manufacturer sold by Mott Manufacturing is limited to the warranty provided by Mott Manufacturing. Products from another manufacturer that have longer warranty's than offered by Mott Manufacturing can be redeemed through the other manufacturer directly.

PART 2 PRODUCTS

2.01 MANUFACTURERS

- A. One manufacturer's product is specified as the basis for design. Design, materials, construction and finish of casework as specified represents the minimum acceptable standard of quality for wood laboratory casework. Subject to compliance with requirements, provide equal products of one of the following or approved equal:
 - 1. Mott Company
562 Industrial Park Rd. Maxwelton, WV, USA 24957
Tel: (519) 752-7825 Email: inquire@mott.ca www.mott.ca
- B. Substitutions: Nationally recognized manufacturers proposing casework different from that specified must submit, at least ten days prior to bid, sufficient documentation (drawings, specifications, construction details and samples) to indicate compliance with the requirements of these specifications, and secure written approval by the Architect in addendum form prior to bid date.

2.02 MATERIALS

- A. Phenolic:
 - 1. Panels produced by a variety of material manufacturers can be selected to be used as the basis of construction material.

2.03 CABINET CONSTRUCTION

- A. Door and Drawer Fronts: Fronts shall be made of 1/2" thick phenolic resin panels. All perimeter edges shall be machine polished and have the edges eased to remove sharpness.
- B. Face Style: Full flush overlay door and drawer faces with 1/8" reveal vertically and horizontally between door and/or drawer faces. Door and drawer faces shall leave 1/16" reveals between door and/or drawer faces and the end panel of a cabinet.
- C. Shelves: Shelves shall be manufactured from 3/4" thick phenolic resin and 1" thick phenolic resin on >30" wide shelves. Shelves shall have the exposed front edge banded with a PVC edge banding. Full depth shelves are standard and shall come to within 3/4" of the face of the cabinet in open units and within 3/4" to the inside face of cabinet doors.
- D. Drawer Bodies: Drawer sides and back are to be constructed from 1/2" thick phenolic resin. Drawer sides shall be attached via dovetail joints at all four corners. Drawer bottom shall be 1/4" phenolic and shall be captured in all four sides of the drawer body and glued completely around the entire bottom.
- E. Cabinet Ends: Cores shall be made of 1/2" thick phenolic resin. All exposed perimeter edges shall be machine polished and have the edges eased to remove sharpness.
- F. Base Cabinet Support Rails: Top rail (front), and intermediate rails between drawers shall be phenolic resin being 3-1/2" by 3/4" thick; captured in slotted cabinet end, and fastened to cabinet end panels from the top or through painted steel angles. Front edges shall be machine polished and eased to remove sharpness. Back rails (top & bottom) shall be phenolic resin 3/4" thick by 6-1/2". Rails shall be fastened to cabinet side panels using painted steel angles and into the floor panel.
- G. Cabinet Backs: Backs shall be made of 1/4" phenolic resin. Base cabinet backs shall be removable without using mechanical fasteners. Floor case and wall cabinet backs shall be fixed in place by means of the whole perimeter being inset into adjacent cabinet components.
 - 1. Optional on drawer cabinets per architect
 - 2. Mandatory on cabinets with doors
 - 3. Sink cabinets to have a partial back to allow for plumbing, etc
- H. Tops and Bottoms of Floor and Wall Cases: Cabinets shall be enclosed with 3/4" thick phenolic resin panels with machine polished front edges. Tops and bottoms are captured by grooves in the end panels as well as fastened through painted steel angles to end panels.

- I. Security Panels: Shall be between all locking doors or drawers and vertically adjacent drawers when locks are specified as keyed differently.
- J. Vertical Dividers: Full height dividers and half height dividers shall be 1/2" thick phenolic resin matching cabinet body, secured to the bottom of the cabinet and top rails with painted steel angles. Exposed edges shall be machine polished to match casework.
- K. Cabinet Bottom Base: Integral base shall support the structure above and provide a toe space that is 3" deep by 4" high. Toe space front shall be made of phenolic resin matching the rest of the cabinet.

2.04 **HARDWARE**

- A. Pulls: Door and drawer pulls shall be rectangular in shape with a brushed aluminum finish mounted vertically on doors and horizontally on drawers. Two pulls shall be required on all drawers over 24" wide.
- B. Hinges: Hinges shall be self-closing 3-knuckle barrel style able to open doors to 165°. Two hinges for doors less than 48" in height and three hinges on doors 48" or above in height.
- C. Locks: Locks shall be provided at all casework drawers and hinged doors. Exposed surface of locks shall be chrome plated. All locks, for the purpose of coordinating keying systems, shall be removable-core disc tumbler type. Locks are keyed individually and to be furnished with master keys.
- D. Drawer Slides: Drawer slides for standard drawers shall be grade '1' 100 lbs ball bearing full extension type, and 200lbs ball bearing full extension type on all file drawers.
- E. Shelf Support Clips: Shelf support clips shall be twin pin plastic seismic shelf supports, for mounting on interior of cabinets. Clips shall be corrosion resistant and shall retain shelves from accidental removal. Shelves are adjustable on 1-1/4" centers.

PART 3 EXECUTION

3.01 INSTALLERS

- A. Installer Qualifications:
 - 1. Installer shall have a minimum of 5 years continued experience in installation or application of systems similar to those required for this project.
 - 2. Installer shall be authorized by either the distributor or manufacturer. Warranty will be void if unauthorized installer executes the installation.

3.02. EXAMINATION

- A. Site Verification of Conditions:
 - 1. Casework will not be delivered or installed until the following conditions have been met:
 - a. Building must be enclosed (windows and doors sealed and weather-tight);
 - b. An operational HVAC system that maintains temperature and humidity at occupancy levels must be in place;
 - c. Ceiling, overhead ductwork and lighting must be installed;
 - d. Site must be free of further construction such as "wet work";
 - e. Required backing and reinforcements must be installed accurately and the project must be ready for casework installation. Abut top edge surfaces in one true plane. Provide flush joints not to exceed 1/8" between top units.

3.03 INSTALLATION

- A. Casework Installation:
 - 1. Casework shall be set with components plumb, straight and square, securely anchored to building structure with no distortion. Concealed shims shall be used

- as required.
2. Cabinets in continuous runs shall be fastened together with joints flush, uniform and tight with misalignment of adjacent units not to exceed 1/16 of an inch.
 3. Wall casework shall be secured to walls that are structural enough to withstand load capacity required by cabinets.
 4. Top edge surfaces shall be abutted in one true plane. Joints are to be flush and gap shall not exceed 1/8 of an inch between tops units.
 5. Casework and hardware shall be adjusted and aligned to allow for accurate connection of contact points and efficient operation of doors and drawers without any warping or binding.
- B. Countertop Installation:
1. Countertops are to have been fabricated in lengths according to drawings, with ends abutting tightly and sealed with corrosion resistant sealant.
 2. Tops will be anchored to base casework in a single true plane with ends abutting at hairline joints with no raised edges at joints.
 3. Joints shall be factory prepared having no need for in-field processing of top and edge surfaces.
 4. Joints shall be dressed smoothly, surface scratches removed and entire surface cleaned thoroughly.

3.04 CLEANING

- A. Ensure all products are unsoiled and match factory finish. Remove or repair damaged or defective units.
- B. Clean all finished surfaces, including drawers and cabinet shelves, and touch up as necessary.
- C. Countertops shall be cleaned and free of grease or streak

3.05 PROTECTION

- A. Counter tops and ledges shall be protected with 1/4" ribbed cardboard for the remainder of the construction process.
- B. Examine casework for damaged or soiled areas; replace, repair, and touch-up as required.
- C. Touch-up, repair or replace damaged products before Substantial Completion.

END OF SECTION 12.35.53

**SECTION 12.36.53
LABORATORY COUNTERTOPS**

PART 1 GENERAL

1.01 SECTION INCLUDES

- A. Epoxy resin countertops and sinks.
- B. Stainless Steel countertops and sinks.
- C. Service fittings and outlets.
- D. Laboratory waste fittings.

1.02 RELATED SECTIONS

- A. Section 12.35.53 –Laboratory Casework.

1.03 REFERENCE STANDARDS

- A. STM D 635 – Standard Test Method for Rate of Burning and/or Extent and Time of Burning of Plastics in a Horizontal Position; 2006.
- B. ASTM E84 – Standard Test Method for Surface Burning of Building Materials; 2015b.
- C. ISSFA-2 – Classification and Standards for Solid Surfacing Material; International Solid Surface Fabricators Association; 2001 (2002).

1.04 SUBMITTALS

- A. Product Data: Manufacturer's data sheets on each product to be used, including:
 - 1. Preparation instruction and recommendations.
 - 2. Storage and handling requirements and recommendations.
 - 3. Specimen warranty.
- B. Shop Drawings: Complete details of materials and installation; combine with shop drawings of cabinets and casework specified in other sections.
 - 1. Layout of countertops and room schedule.
 - 2. Locations and preparation for plumbing fixtures, fittings, equipment, and accessories installed in countertops.
- C. Selection Samples: For each finish product specified, color chips representing manufacturer's full range of available colors and patterns.
- D. Installation Instructions: Manufacturer's installation instructions and recommendations.
- E. Maintenance Data: Manufacturer's instructions and recommendations for maintenance and repair of countertop surfaces.

1.05 QUALITY ASSURANCE

- A. Single Source: Laboratory countertops shall be furnished by the wood laboratory casework company.
- B. Epoxy Resin Installer Qualifications: Company specializing in installation of the products specified in this section with a minimum three years of documented experience.

1.06 DELIVERY, STORAGE, AND HANDLING

- A. Store products in manufacturer's unopened packaging until ready for installation.
- B. Store and dispose of solvent-based materials used with solvent-based materials, in accordance with requirements of local authorities having jurisdiction.
- C. Protect plastic laminate tops from moisture damage.
- D. Do not deliver countertops until painting, wet work, grinding, and similar operations have been completed in installation areas.

1.07 FIELD CONDITIONS

- A. Maintain environmental conditions (temperature, humidity, and ventilation) within limits recommended by manufacturer for optimum results. Do not install products under

environmental conditions outside manufacturer's absolute limits.

1. Building shall be enclosed, wet work shall be complete, and HVAC system shall be operating and maintaining temperature and relative humidity at occupancy levels during the remainder of the construction period.
- B. Field Measurements: Where countertop is indicated to be fitted to other construction, check actual dimensions of other construction by accurate field measurements before manufacturing countertop; show recorded measurements on shop drawings. Coordinate manufacturing schedule with construction progress to avoid delay of Work.
1. Where field measurements cannot be made without delaying the Work, guarantee dimensions and proceed with manufacture of countertop without field measurements. Coordinate other construction to ensure that actual dimensions correspond to guaranteed dimensions.

PART 2 PRODUCTS

2.01 EPOXY RESIN COUNTERTOPS

- A. Filled epoxy resin molded into homogenous, non-porous sheets; no surface coating and color and pattern consistent throughout thickness; with integral or adhesively seamed components.
- B. Physical Properties:
1. Chemical Resistance: Uncoated material shall withstand spot test with the following reagents in standard laboratory concentrations for 24 hours.
 - a. No Effect: Hydrochloric acid, sulfuric acid 40%, acetic acid, ammonium hydroxide, ethyl alcohol, nitric acid 40%, potassium hydroxide, sodium hydroxide, sodium hypochlorite, ethylene dichloride, methyl alcohol, ether, carbon tetrachloride, gasoline, mineral oil.
 - b. Slight Effect: Chromic acid 40%, nitric acid 70%, acetic acid, ethyl acetate, benzene.
 2. Flammability: Self-extinguishing, when tested in accordance with ASTM D635.
 3. Water Absorption: Maximum of 0.020%, when tested in accordance with ASTM D570.
 4. Rockwell Hardness "M": Minimum of 100, when tested in accordance with ASTM D785.
 5. Flexural Strength: Minimum of 10,000 psi (70 MPa), when tested in accordance with ASTM D790.
 6. Heat and Flame Resistance:
 - a. A porcelain crucible heated over a Bunsen burner until the crucible bottom attained a dull, red color. Immediately transfer to the work surface and allow to cool to room temperature. No effect on the work surface.
 - b. Overturn a 3/8 inch Bunsen burner, adjusted to quiet flame with a 1-1/2 inch inner cone, remain on the work surface for a period of five (5) minutes with no effect.
- C. Flat Surface Thickness: 1-inch thick (plus or minus 1/32 inch).
- D. Color: Non-glaring black.
- E. Exposed Edge and Corner Shape: 3/16 inch radius corner.
- F. Edge Overhang: Front overhang of 1 inch from cabinet base (inside of overlay door), with continuous drip groove on under surface. Provide side cabinet overhangs 1/4 inch except where shown otherwise and as required to fit to abutting equipment.
- G. Drip Edge: 1/8-inch wide and deep, located 1/2 inch back from edge on underside of all exposed edges.
- H. Back and End Splashes: Same material, thickness and finish as the countertop; 4 inch high, supplied loose for field application, butt jointed and cemented to top. Provide where indicated on drawings. Include end splash where countertop abuts end wall.
- I. In so far as possible fabricate in factory. Prepare sink and other required openings so

- exposed edges are finished same as top.
- J. Fabricate in maximum practicable lengths, as follows or longer if available:
 - 1. Epoxy Resin - 8 feet.
 - K. Make smooth, clean, exposed tops and edges, in uniform plane, free of defects, edges and corners uniformly rounded.
 - L. Maintain thickness 1 inch (plus or minus 1/32 inch). Provide front overhang of 1 inch from cabinet base (inside of overlay door), with continuous drip groove on under surface. Side cabinet overhangs 1/4 inch except where shown otherwise and as required to fit to abutting equipment.

2.02 EPOXY SINKS AND CUPSINKS

- A. Cast Epoxy Resin Sinks: Drop-in type, non-glare black, molded in one piece with surfaces smooth, corners coved and bottom sloped to outlet. Minimum physical properties and chemical resistance as specified for cast epoxy resin tops. Minimum thickness 5/8 inch.
 - 1. Sizes: 19" w. x 18" l. x 5" h..
- B. Cabinet Sink Supports: Support sinks on 11 gauge, adjustable, 1" x 2" x 1" channel with reagent resistant finish. Provide two channels across width of cabinet, attached to 3/8 inch diameter threaded hanger rods.
- C. Waste Fittings: Provide for each sink specified in this section, the following items:
 - 1. Sink Outlets: 1-1/2 inch diameter, 6 inch minimum length, fabricated of silicon, iron, cast epoxy resin, stainless steel, glass or lead; of same material as sink wherever possible, or as otherwise acceptable to Architect.
 - 2. Sink Overflows: Furnish for sink of standard beehive or open top type with separate strainer. Height 2 inches less than sink depth. Construct of same material as sink.
 - 3. Tail pieces, traps and drain lines to be furnished and installed by others.

2.03 STAINLESS STEEL WORKSURFACE

- A. Material:
 - 1. 316 stainless steel with a #4 brushed finish
 - 2. 16Ga.
- B. Methods: All factory welds shall be made using the TIG process. Filler rod shall be of the same composition as the base material.
- C. Tops: Form tops with 1.25" high (32mm) edges with 0.5" (12mm) return flange. Reinforce with metal hat channels as required. Form edges, flanges and backsplashes integrally from one sheet of steel. Intersections between backsplashes and work surface shall be radiused a minimum of 0.375" (9mm).
- D. Sink Tops: Form tops with 1.25" high (32mm) edges with 0.5" (12mm) return flange. Marine edges shall integrally formed on all edges. Marine edges shall be 1" (25mm) wide and 0.25" (6mm) high. Work surface shall be reinforced with wood core or metal hat channels as required. Form edges, flanges and backsplashes integrally from one sheet of steel. Intersections between backsplashes and work surface shall be radiused a minimum of 0.375" (9mm).
- E. Sink Bowls: Sink bowls shall be made of the same material as the work surface and shall be of equal or greater thickness. Sinks bowls shall be formed from one piece of steel with all inside corners radiused. Welds shall be hammered, ground and polished to produce a smooth, invisible joint. Sinks shall be welded into the work surface and welds shall be ground and polished to produce a smooth, invisible joint.
 - 1. Size: 18 inches x 22 inches x 10 inches deep.
- F. Joints: Factory welds shall be ground and polished to provide an invisible joint. Field connections shall be mechanical "tongue and groove" interlocking design with concealed bolts to provide a hairline seam.
- G. Sound Deadener: Countertops and sinks shall have sound deadening material applied as required to the underside. Nominal thickness shall be 0.062" (1.5mm). Sound deadener

shall be waterborne, non flammable and shall contain no volatile organic compounds.

2.02 SERVICE FITTINGS

- A. Water Service Fittings:
1. Water Service Faucets and Valves: Provide with renewable unit containing all working parts subject to wear, including replaceable stainless steel seat. Unit shall have serrations for position locking into valve body.
 2. Gooseneck Vacuum Breakers: Brass forgings integral with gooseneck, with renewable seat and special design valve member for fine flow control.
 3. Goosenecks: Provide separate 3/8" IPS coupling securely brazed to gooseneck to provide full thread for attachment of anti-splash outlet fittings, serrated tips and filter pumps. Furnish with hose nozzle.
 4. Manufacturer: Water Saver Faucet Company or approved equal.
 5. Service Fitting Schedule:
 - a. Hot and Cold Water Supply: Water Saver # L2212VB.
 - b. Accessible Locations: Delta 621TPA3350-SS plus new mixing valve.

PART 3 EXECUTION

3.01 INSTALLATION OF COUNTERTOPS

- A. Field Jointing: Where practicable, make in same manner as factory jointing using dowels, splines, adhesives, and fasteners recommended by manufacturer. Locate field joints as shown on accepted shop drawings, factory prepared so that there is no job site processing of top and edge surfaces.
- B. Fastenings: Use concealed clamping devices for field joints:
1. Secure epoxy tops to cabinets with epoxy cement applied at each corner and along perimeter edges at not more than 38 inch o.c.
- C. Workmanship:
1. Abut top and edge surfaces in one true plane, with internal supports placed to prevent any deflection.
 2. Provide flush hairline joints in top units using clamping devices.
 3. At stone-type material joints, use manufacturer's recommended adhesives and holding devices to provide joint widths not more than 1/16 inch wide at any location, completely filled and flush with abutting edges.
 4. Where necessary to penetrate tops with fasteners, countersink heads approximately 1/8 inch and plug hole flush with material equal in chemical resistance, color, hardness, and texture to top surface.
 5. Provide all holes and cutouts as required for mechanical and electrical service fixtures specified in Divisions 11, 22 and 26, and as otherwise required.

3.02 INSTALLATION OF ACCESSORIES

- A. Install in a precise manner in accordance with manufacturer's directions.
- B. Turn screws to a flat seat; do not drive.
- C. Epoxy Sink Installation: Epoxy cement weld sink to adjacent resin top to achieve a hidden waterproof joint. Caulk joint between top and sink with non-hardening mastic.
- D. Provide all holes and cutouts as required for mechanical and electrical service fixtures specified as required.

3.03 CLEANING

- A. After installation, carefully dress joints smooth, remove any surface scratches, clean and polish entire surface.
- B. Clean all accessories, and fittings.

END OF SECTION 12.36.53

E. Terms and Conditions

I. Terms and Conditions

- a. **Acceptance or rejection:** PSU reserves the right to accept or reject any or all bids or part of a bid; to waive any informalities or technicalities; clarify any ambiguities in bids; and unless otherwise specified, to accept any item in the bid.
- b. The provisions found in Contractual Provisions Attachment (DA 146a) are incorporated by reference and made a part of this contract.
- c. In the event of a conflict in terms of language among the documents, the following order of precedence shall govern:
- * Form DA 146a;
 - * written modifications to the executed contract;
 - * written contract signed by the parties;
 - * the Bid Event documents, including any and all amendments; and
 - * Contractor's written offer submitted in response to the Bid Event as finalized.
- d. Each and every provision of law and clause required by law to be inserted in the contract shall be deemed to be inserted herein and the contract shall be read and enforced as though it were included herein. If through mistake or otherwise any such provision is not inserted, or is not correctly inserted, then on the application of either party the contract shall be amended to make such insertion or correction.
- e. This contract shall be governed by the laws of the State of Kansas and shall be deemed executed in Pittsburg, Crawford County, Kansas.
- f. The parties shall bring any and all legal proceedings arising hereunder in the State of Kansas, District Court of Crawford County, unless otherwise specified and agreed upon by PSU. The United States District Court for the State of Kansas sitting in Topeka, Shawnee County, Kansas, shall be the venue for any federal action or proceeding arising hereunder in which the State is a party.
- g. **Termination for Cause**
The PSU Director of Purchasing may terminate this contract, or any part of this contract, for cause under any one of the following circumstances:
- * the Contractor fails to make delivery of goods or services as specified in this contract;
 - * the Contractor provides substandard quality or workmanship;
 - * the Contractor fails to perform any of the provisions of this contract, or
 - * the Contractor fails to make progress as to endanger performance of this contract in accordance with its terms.

The PSU Director of Purchasing shall provide Contractor with written notice of the conditions endangering performance. If the Contractor fails to remedy the conditions within ten (10) days from the receipt of the notice (or such longer period as PSU may authorize in writing), the PSU Director of Purchasing shall issue the Contractor an order to stop work immediately. Receipt of the notice shall be presumed to have occurred within three (3) days of the date of the notice.

h. The PSU Director of Purchasing may terminate performance of work under this contract in whole or in part whenever, for any reason, the PSU Director of Purchasing shall determine that the termination is in the best interest of PSU. In the event that the PSU Director of Purchasing elects to terminate this contract pursuant to this provision, it shall provide the Contractor written notice at least 30 days prior to the termination date. The termination shall be effective as of the date specified in the notice. The Contractor shall continue to perform any part of the work that may have not been terminated by the notice.

i. Hold Harmless - The Contractor shall indemnify PSU against any and all loss or damage to the extent arising out of the Contractor's negligence in the performance of services under this contract and for infringement of any copyright or patent occurring in connection with or in any way incidental to or arising out of the occupancy, use, service, operations or performance of work under this contract.

PSU shall not be precluded from receiving the benefits of any insurance the Contractor may carry which provides for indemnification for any loss or damage to property in the Contractor's custody and control, where such loss or destruction is to state property. The Contractor shall do nothing to prejudice PSU's right to recover against third parties for any loss, destruction or damage to PSU property.

j. Force Majeure - The Contractor shall not be held liable if the failure to perform under this contract arises out of causes beyond the control of the Contractor. Causes may include, but are not limited to, acts of nature, fires, tornadoes, quarantine, strikes other than by Contractor's employees, and freight embargoes.

k. The Contractor shall not assign, convey, encumber, or otherwise transfer its rights or duties under this contract without the prior written consent of PSU. PSU may reasonably withhold consent for any reason. This contract may terminate for cause in the event of its assignment, conveyance, encumbrance or other transfer by the Contractor without the prior written consent of PSU.

l. The Contractor shall be the sole source of contact for the contract. PSU will not subcontract any work under the contract to any other firm and will not deal with any subcontractors. The Contractor is totally responsible for all actions and work performed by its subcontractors. All terms, conditions and requirements of the contract shall apply without qualification to any services performed or goods provided by any subcontractor.

m. Both parties, in the performance of this contract, shall be acting in their individual capacity and not as agents, employees, partners, joint ventures or associates of one another. The employees or agents of one party shall not be construed to be the employees or agents of the other party for any purpose whatsoever. The Contractor accepts full responsibility for payment of unemployment insurance, workers compensation, social security, income tax deductions and any other taxes or payroll deductions required by law for its employees engaged in work authorized by this contract.

n. Upon request, the Contractor shall present an affidavit of Worker's Compensation, Public Liability, and Property Damage Insurance to Procurement and Contracts.

o. The Contractor agrees to abide by all federal, state and local laws, and rules and regulations prohibiting discrimination in employment and controlling workplace safety. Any violations of applicable laws or rules or regulations may result in termination of this contract.

- p. The Contractor shall abide by all federal, state and local laws, and rules and regulations regarding the protection of the environment. The Contractor shall report any violations to the applicable governmental agency. A violation of applicable laws or rule or regulations may result in termination of this contract for cause.
- r. The Contractor shall be responsible for the proper care and custody of any state owned personal tangible property and real property furnished for Contractor's use in connection with the performance of this contract. The Contractor shall reimburse the PSU for such property's loss or damage caused by the Contractor, except for normal wear and tear.
- s. Failure to adequately inspect the premises shall not relieve the Contractor from furnishing without additional cost to PSU any materials, equipment, supplies or labor that may be required to carry out the intent of this Contract.
- t. Price Adjustments - Prices shall remain firm for the entire contract period. Prices shall be net delivered, including all trade, quantity and cash discounts. Any price reductions available during the contract period shall be offered to PSU. Failure to provide available price reductions may result in termination of the contract for cause.
- u. Payment - Payment Terms are Net 30 days. Payment date and receipt of order date shall be based upon K.S.A. 75-6403(b).
- v. Materials and Workmanship - The Contractor shall perform all work and furnish all supplies and materials, machinery, equipment, facilities, and means, necessary to complete all the work required by this Contract, within the time specified, in accordance with the provisions as specified. The Contractor shall be responsible for all work put in under these specifications and shall make good, repair and/or replace, at the Contractor's own expense, as may be necessary, any defective work, material, etc., if in the opinion of agency and/or Procurement and Contracts said issue is due to imperfection in material, design, workmanship or Contractor fault.
- w. New Materials, Supplies or Equipment - Unless otherwise specified, all materials, supplies or equipment offered by the Contractor shall be new, unused in any regard and of most current design. All materials, supplies and equipment shall be first class in all respects. Seconds or flawed items will not be acceptable. All materials, supplies or equipment shall be suitable for their intended purpose and, unless otherwise specified, fully assembled and ready for use on delivery
- x. Inspection - PSU reserves the right to reject, on arrival at destination, any items which do not conform with specification of the Contract.
- y. Modification - This contract shall be modified only by the written agreement and approval of the parties. No alteration or variation of the terms and conditions of the contract shall be valid unless made in writing and signed by the parties. Every amendment shall specify the date on which its provisions shall be effective.

CONTRACTUAL PROVISIONS ATTACHMENT

Important: This form contains mandatory contract provisions and must be attached to or incorporated in all copies of any contractual agreement. If it is attached to the vendor/contractor's standard contract form, then that form must be altered to contain the following provision:

The Provisions found in Contractual Provisions Attachment (Form DA-146a, Rev. 07-19), which is attached hereto, are hereby incorporated in this contract and made a part thereof.

The parties agree that the following provisions are hereby incorporated into the contract to which it is attached and made a part thereof, said contract being the _____ day of _____, 20____.

1. **Terms Herein Controlling Provisions:** It is expressly agreed that the terms of each and every provision in this attachment shall prevail and control over the terms of any other conflicting provision in any other document relating to and a part of the contract in which this attachment is incorporated. Any terms that conflict or could be interpreted to conflict with this attachment are nullified.
2. **Kansas Law and Venue:** This contract shall be subject to, governed by, and construed according to the laws of the State of Kansas, and jurisdiction and venue of any suit in connection with this contract shall reside only in courts located in the State of Kansas.
3. **Termination Due To Lack Of Funding Appropriation:** If, in the judgment of the Director of Accounts and Reports, Department of Administration, sufficient funds are not appropriated to continue the function performed in this agreement and for the payment of the charges hereunder, State may terminate this agreement at the end of its current fiscal year. State agrees to give written notice of termination to contractor at least thirty (30) days prior to the end of its current fiscal year and shall give such notice for a greater period prior to the end of such fiscal year as may be provided in this contract, except that such notice shall not be required prior to ninety (90) days before the end of such fiscal year. Contractor shall have the right, at the end of such fiscal year, to take possession of any equipment provided State under the contract. State will pay to the contractor all regular contractual payments incurred through the end of such fiscal year, plus contractual charges incidental to the return of any such equipment. Upon termination of the agreement by State, title to any such equipment shall revert to contractor at the end of the State's current fiscal year. The termination of the contract pursuant to this paragraph shall not cause any penalty to be charged to the agency or the contractor.
4. **Disclaimer Of Liability:** No provision of this contract will be given effect that attempts to require the State of Kansas or its agencies to defend, hold harmless, or indemnify any contractor or third party for any acts or omissions. The liability of the State of Kansas is defined under the Kansas Tort Claims Act (K.S.A. 75-6101, *et seq.*).
5. **Anti-Discrimination Clause:** The contractor agrees: (a) to comply with the Kansas Act Against Discrimination (K.S.A. 44-1001, *et seq.*) and the Kansas Age Discrimination in Employment Act (K.S.A. 44-1111, *et seq.*) and the applicable provisions of the Americans With Disabilities Act (42 U.S.C. 12101, *et seq.*) (ADA), and Kansas Executive Order No. 19-02, and to not discriminate against any person because of race, color, gender, sexual orientation, gender identity or expression, religion, national origin, ancestry, age, military or veteran status, disability status, marital or family status, genetic information, or political affiliation that is unrelated to the person's ability to reasonably perform the duties of a particular job or position; (b) to include in all solicitations or advertisements for employees, the phrase "equal opportunity employer"; (c) to

comply with the reporting requirements set out at K.S.A. 44-1031 and K.S.A. 44-1116; (d) to include those provisions in every subcontract or purchase order so that they are binding upon such subcontractor or vendor; (e) that a failure to comply with the reporting requirements of (c) above or if the contractor is found guilty of any violation of such acts by the Kansas Human Rights Commission, such violation shall constitute a breach of contract and the contract may be cancelled, terminated or suspended, in whole or in part, by the contracting state agency or the Kansas Department of Administration; (f) Contractor agrees to comply with all applicable state and federal anti-discrimination laws and regulations; (g) Contractor agrees all hiring must be on the basis of individual merit and qualifications, and discrimination or harassment of persons for the reasons stated above is prohibited; and (h) if it is determined that the contractor has violated the provisions of any portion of this paragraph, such violation shall constitute a breach of contract and the contract may be canceled, terminated, or suspended, in whole or in part, by the contracting state agency or the Kansas Department of Administration.

6. **Acceptance of Contract:** This contract shall not be considered accepted, approved or otherwise effective until the statutorily required approvals and certifications have been given.
7. **Arbitration, Damages, Warranties:** Notwithstanding any language to the contrary, no interpretation of this contract shall find that the State or its agencies have agreed to binding arbitration, or the payment of damages or penalties. Further, the State of Kansas and its agencies do not agree to pay attorney fees, costs, or late payment charges beyond those available under the Kansas Prompt Payment Act (K.S.A. 75-6403), and no provision will be given effect that attempts to exclude, modify, disclaim or otherwise attempt to limit any damages available to the State of Kansas or its agencies at law, including but not limited to, the implied warranties of merchantability and fitness for a particular purpose.
8. **Representative's Authority to Contract:** By signing this contract, the representative of the contractor thereby represents that such person is duly authorized by the contractor to execute this contract on behalf of the contractor and that the contractor agrees to be bound by the provisions thereof.
9. **Responsibility for Taxes:** The State of Kansas and its agencies shall not be responsible for, nor indemnify a contractor for, any federal, state or local taxes which may be imposed or levied upon the subject matter of this contract.
10. **Insurance:** The State of Kansas and its agencies shall not be required to purchase any insurance against loss or damage to property or any other subject matter relating to this contract, nor shall this contract require them to establish a "self-insurance" fund to protect against any such loss or damage. Subject to the provisions of the Kansas Tort Claims Act (K.S.A. 75-6101, *et seq.*), the contractor shall bear the risk of any loss or damage to any property in which the contractor holds title.
11. **Information:** No provision of this contract shall be construed as limiting the Legislative Division of Post Audit from having access to information pursuant to K.S.A. 46-1101, *et seq.*
12. **The Eleventh Amendment:** "The Eleventh Amendment is an inherent and incumbent protection with the State of Kansas and need not be reserved, but prudence requires the State to reiterate that nothing related to this contract shall be deemed a waiver of the Eleventh Amendment."
13. **Campaign Contributions / Lobbying:** Funds provided through a grant award or contract shall not be given or received in exchange for the making of a campaign contribution. No part of the funds provided through this contract shall be used to influence or attempt to influence an officer or employee of any State of Kansas agency or a member of the Legislature regarding any pending legislation or the awarding, extension, continuation, renewal, amendment or modification of any government contract, grant, loan, or cooperative agreement.