

**02 - FINISH PLAN**  
1/8" = 1'-0"

**GENERAL NOTES**

1. SEE CALLOUTS ON FINISH PLAN FOR COUNTERTOP FINISHES.

**FINISH PLAN LEGEND**

**FLOOR FINISHES:**

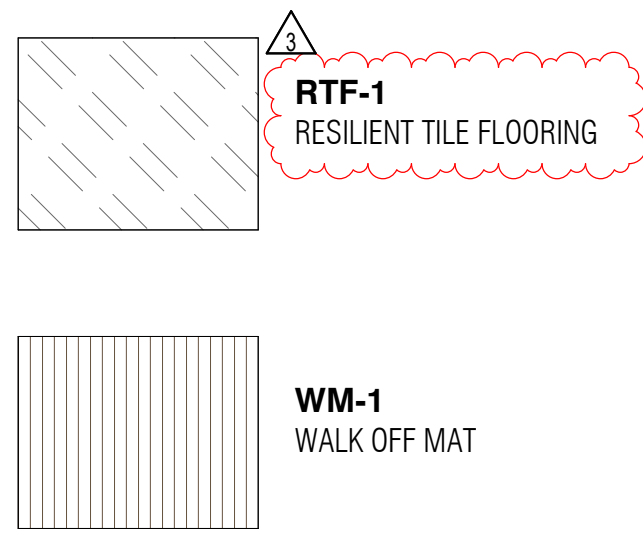
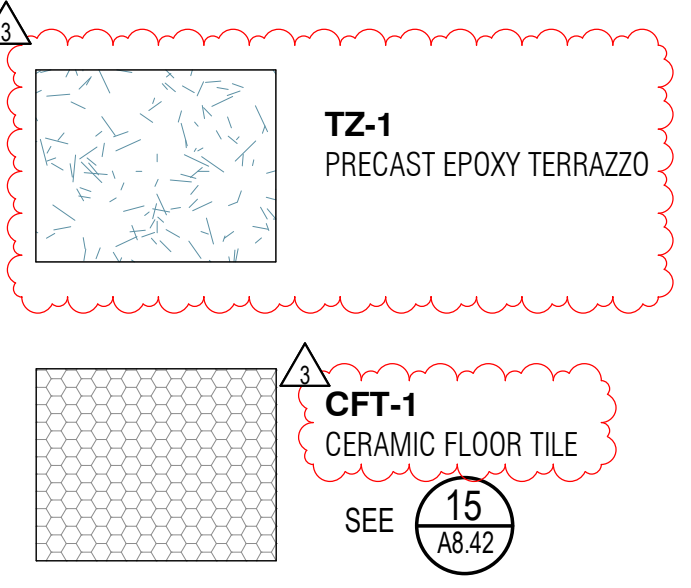
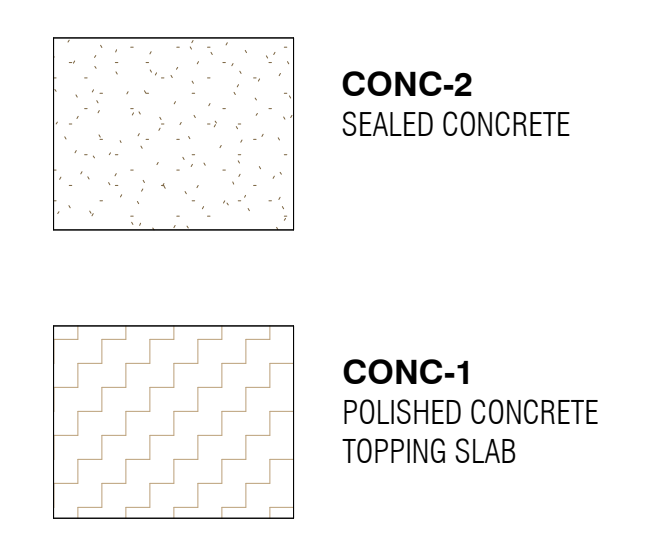
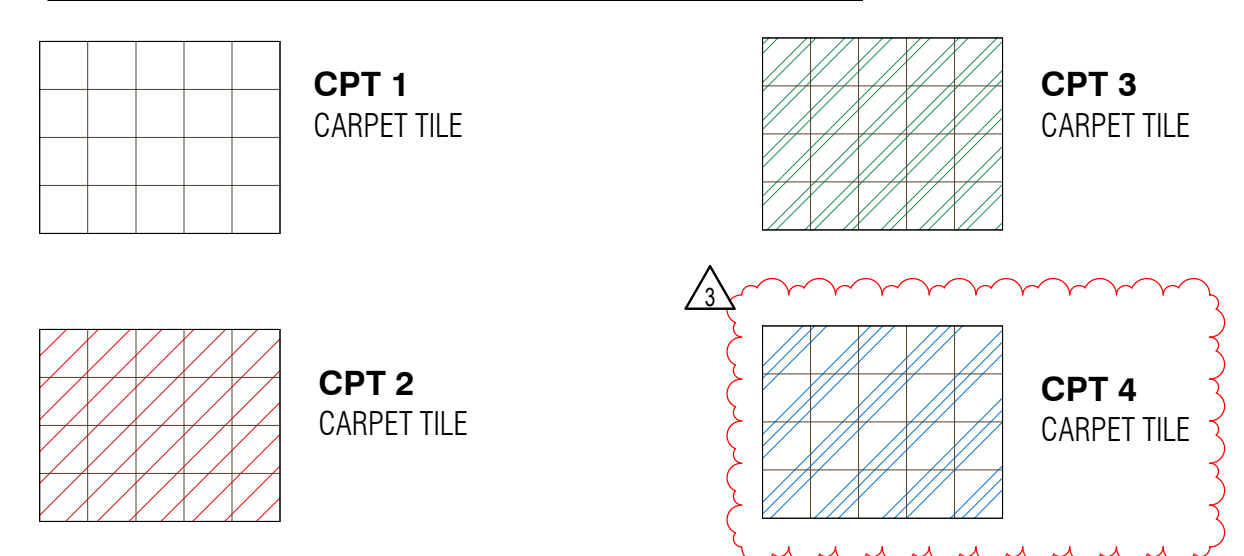

**GLAZING SYSTEM TYPES:**

SEE EXT ELEVATIONS FOR EXTERIOR GLAZING TYPES  
GS4 INTERIOR ALUMINUM STOREFRONT  
GS5 ALUMINUM STOREFRONT - UPGRADED FOR TALLER SPANS, BUTT-GLAZING, LAMINATED GLASS  
GS6 ACOUSTICAL WINDOW SYSTEM