



INVITATION TO BID (ITB) NO. 1013-0-2022/LD

**PURCHASE AND INSTALLATION OF
INTERACTIVE FLAT PANELS (IFP)**

**PURCHASING DEPARTMENT
2845 SE DIXIE HWY
STUART, FLORIDA, 34997
TEL (772) 219-1255
EMAIL bids@martinschools.org**



**NOTICE OF
INVITATION TO BID**

Bid documents must be submitted electronically through www.DemandStar.com or bids@martinschools.org by responding no later than the designated deadline date and time. A Bidder’s failure to submit as required before the deadline shall cause their bid to be disqualified. Under no circumstances shall bids delivered to or received by the District or Demandstar after the Due Date and Time be accepted or considered. Late bids will be retained unopened.

Solicitation Documents may be obtained by registering with www.DemandStar.com or from www.vendorregistry.com. Bidders who obtain solicitation documents from any other source are cautioned that the solicitation package may be incomplete. Furthermore, all addenda issued will be posted and disseminated by DemandStar to planholders/members.

The following meeting dates are subject to change according to the needs of the District.

ITB Number:	1013-0-2022/LD
ITB Name:	Purchase & Installation of Interactive Flat Panels (IFP)
ITB Advertising/Publish Dates:	April 18, 2022
Questions Deadline:	April 21, 2022 by no later than 2:00pm
ITB Closing Date/Time:	April 28, 2022 By No Later Than 2:00pm
Anticipated Award Date	May 22, 2022
Contact Information:	Email: bids@martinschools.org
Email Notifications:	Start all email subject lines with the ITB number for faster recognition.
Submittal Requirements:	Submit bid by completing and returning all required documents. All submittals are required to be electronic and be contained in one (1) file. Hard copies, mailed, or facsimile responses shall not be accepted. Under no circumstances shall bids delivered to or received by the District or Demandstar after the Due Date and Time be accepted or considered. Late proposals will be retained unopened. It is the sole responsibility of the Bidder to assure that their submittal is uploaded to DemandStar or bids@martinschools.org on or before the Due Date and Time. The District shall in no way whatsoever be responsible for any delays caused by any power outages or internet failures. No exceptions will be made.
Submit Bid to::	Bidder shall submit their bid indicating Bidder’s name and Project Name, ITB Number, and time and date of the ITB opening. Bids shall be submitted electronically through www.DemandStar.com or bids@martinschools.org .
ITB Scope of Work:	The Martin County School Board is seeking bids from pre-qualified firms to purchase and install failing audio-visual (AV) equipment in accordance with the specifications, on an as needed basis, for an initial one (1) year period, effective from award through June 30, 2023 with two (2) one year renewal options.

Bidders may not withdraw their bid submittal for a period of ninety (90) calendar days after the day set for the opening of bids.

The District reserves the right to waive any informalities or irregularities, reject any and all bids that are incomplete, conditional, non-responsive, or which contain additions not allowed for; to reject any or all bids in whole or in part with or without cause; to award in whole or in part to one or more Bidders, and to accept the bid which best serves the District.



ADVERTISEMENT PUBLICATION

Martin County School Board
2845 S.E. Dixie Highway
Stuart, FL 34997

**ITB# 1013-0-2022/LD
INTERACTIVE FLAT PANELS**

The Martin County School Board is seeking bids from qualified firms to purchase and install interactive flat panels (IFP) on an as needed basis for an initial one (1) year period effective from award through June 30, 2023 with two (2) one year renewal options.

Solicitation Documents may be obtained by registering with www.DemandStar.com or from www.vendorregistry.com. The District is not responsible for the content of any submittal package received through any 3rd party service or any other source.

Firms desiring to provide the services described shall submit one (1) complete electronic submittal, contained in one (1) file, PDF format preferred, submitted electronically through www.DemandStar.com or bids@martinschools.org containing all of the required information **no later than 2:00pm, April 28, 2022.**

Questions: Email bids@martinschools.org by no later than 2:00 pm eastern time on April 21, 2022.

Publish Date: 4/18/22



Table of Contents

ITB NOTICE – ADVERTISEMENT/PUBLICATION LN

SECTION I – DEFINITIONS, ABBREVIATIONS, & ACRONYMS 1

SECTION II – INSTRUCTIONS TO BIDDERS 7

SECTION III – GENERAL TERMS AND CONDITIONS 16

SECTION IV – INSURANCE REQUIREMENTS 22

SECTION V – SPECIAL CONDITIONS 25

 5.1 QUALIFICATIONS OF BIDDERS 25

 5.2 MEETING SCHEDULE 26

 5.3 BUSINESS OPERATIONS 26

 5.4 BRAND NAME SPECIFIC 26

 5.5 BADGE POLICY 26

 5.6 AWARD METHOD 26

 5.7 METHOD OF ORDERING 27

 5.8 QUALITY ASSURANCE & RETURNED GOODS 27

 5.9 PERFORMANCE 27

 5.10 STANDARDS/REGUALTIONS 27

 5.11 IDENTIFICATION 27

 5.12 INSPECTION OF FACILITIES 27

 5.13 CONDUCT 28

 5.14 POST SALE AUDIT ADJUSTMENT 28

 5.15 ADDITIONAL DISCOUNTS/PROMOTIONS 28

 5.16 PRODUCT RECALL 28

 5.17 PROTECTION OF PROPERTY 29

 5.18 DEBRIS 29

 5.19 PAYMENT & PERFORMANCE BONDS 29

SECTION VI – SCOPE OF WORK 30

 6.1 WORK OBJECTIVE 30

 6.2 COMPLETION TIME 30

 6.3 INSPECTION & TESTING 31

 6.4 SERVICING PROCEDURES 31

 6.5 WORKMANSHIP 32

 6.6 EQUIPMENT / MATERIALS /PARTS 32

 6.7 ASSEMBLY AND/OR PLACEMENT 37

 6.8 COOPERATION WITH DISTRICT 37

 6.9 WARRANTY 37

 6.10 PRICING AND INVOICING 37

 6.11 SAMPLE FORMS 38

SECTION VII – FORMS 39

 7.1 COVER PAGE CHECKLIST 39

 7.2 BID FORM 39

 7.3 SCHEDULE OF PRICES 39

 7.4 BIDDER’S QUALIFICATION’S QUESTIONNAIRE 39

 7.5 SUBCONTRACTOR LIST 39

 7.6 WARRANTIES 39

 7.7 REFERENCE FORM 39

 7.8 NON-COLLUSIVE AFFIDAVIT 39

 7.9 CONFLICT OF INTEREST 39

 7.10 DRUG FREE WORKPLACE 39

 7.11 PUBLIC ENTITY CRIMES 39

 7.12 NO BID 39

SECTION VIII – SAMPLE AGREEMENT 40

SECTION IX – MCSD PROJECT SPECIFICATIONS 53



SECTION I

DEFINITIONS, ABBREVIATIONS, & ACRONYMS

Wherever used in the Contract Documents the following terms have the meanings indicated in the industry which are applicable to both the singular and plural thereof:

1.1. **Acceptance:** By the DISTRICT'S PROJECT MANAGER of the Work as being fully complete in accordance with the Contract Documents.

1.2. **Addenda:** Written or graphic instruments issued prior to the opening of Bids which clarify, correct or change the Bidding Requirements or the Contract

1.3. **Application for Payment:** The form accepted by the CONSULTANT which is to be used by CONTRACTOR to request progress payments or final payment and which is to be accompanied by such supporting documentation as is required by the Contract Documents.

1.4. **Bid:** The formal firm price offer of the BIDDER submitted on the prescribed form setting forth the prices for the WORK in response to the Invitation to Bid.

1.5. **Bidder:** Any person, firm or corporation submitting a Bid for the Work directly to the DISTRICT. As used in this Invitation to Bid, the words proposer and contractor may be used interchangeably to mean Bidder.

1.6. **Bid Documents:** Includes the Invitation to Bid, Instructions to Bidders, Bid Form, and proposed Contract Documents (including all Addenda issued prior to receipt of Bids).

1.7. **Bonds:** Bid security/guarantee, performance, and payment bonds and other instruments of security, furnished by the CONTRACTOR and his surety in accordance with the Contract Documents and in accordance with the law of the place of the project.

1.8. **Cable:** An assembly of one or more insulated conductors or optical fibers, within an enveloping sheath.

1.9. **Certified Contractor:** Any contractor who possesses a certificate of competency issued by the department and who shall be allowed to contract in any jurisdiction in the state without being required to fulfill the competency requirements of that jurisdiction.

1.10. **Change Order:** A written order to the CONTRACTOR executed by the DISTRICT, CONSULTANT, and CONTRACTOR authorizing an addition, deletion or revision in the Work, or an adjustment in the Contract Price or the Contract Time issued after execution of the Contract.

1.11. **Consultant/Engineer of Record:** The Architect or Engineer, if applicable, also referred to as **EOR (Engineer or Record)**, firm or corporation named as such in the Contract Documents that acts as the District's authorized agent within the scope of work entrusted to them by the District.

1.12. **Consultant's Representative:** An authorized representative of the Consultant assigned to observe the work performed and materials furnished by the CONTRACTOR.

1.13. **Contract:** The written agreement between DISTRICT and CONTRACTOR covering the WORK to be performed.

1.14. **Contract Documents:** The Contract Documents establish the rights and obligations of the parties. The Notice of Tentative Award, including the contract is directed for signature as acceptance of offer by the Contractor, prior to Board approval for award. Once approved, a notice of award requesting the bonds and insurance are requested. The executed contract documents, including exhibits (solicitation/submittal), bonds, and insurance are provided to the Contractor. Consultant's written interpretations and clarifications issued on or after the Effective Date of the Contract.

Please review Section VIII, Sample Contract, and note any objections, or revisions that would be required within the submittal. Should no revisions be noted, the District will assume and the Contractor agrees that the terms and conditions of agreement are acceptable. The proposed Agreement does not authorize the performance of any work.

Approved Shop Drawings and the reports and drawings of subsurface and physical conditions are not Contract Documents. Only printed or hard copies of the items listed in this paragraph are Contract Documents. Files in electronic media format of text, data, graphics, and the like that may be furnished by DISTRICT to CONTRACTOR are not Contract Documents.

1.15. **Contract Price:** The total monies payable by the DISTRICT to the CONTRACTOR under the terms and conditions of the Contract Document.

1.16. **Contract Time:** The number or numbers of successive days or dates stated in the Contract Documents for the completion of the WORK.

1.17. **Contractor:** The individual, partnership, corporation, joint-venture, or other legal entity with whom the DISTRICT has entered into the Contract. Can be used interchangeably with the term bidder and / or vendor.

1.18. **Day:** A calendar day of 24 hours measured from midnight to the next midnight.

1.19. **Defective Work:** WORK that is unsatisfactory, faulty, or deficient; or that does not conform to the Contract Documents; or that does not meet the requirements of any inspection, reference standard, test, or approval referred to in the Contract Documents; or WORK that has been damaged prior to the CONSULTANT'S recommendation of final payment.

1.20. **District:** The Martin District School District, Florida, a Florida school district, its authorized and legal representatives, the public entity with whom the Contractor has entered into the Contract and for whom the WORK is to be provided.

1.21. **District Representative:** The person or persons designated by the DISTRICT'S PROJECT MANAGER. The DISTRICT'S PROJECT MANAGER. This may include the CONSULTANT/EOR.

1.22. **DP:** Dead pairs: Unused copper pairs terminating within splice case, but without being splices to outgoing cable.

1.23. **Drawings:** The drawings, plans, maps, profiles, diagrams, and other graphic representations which show character, location, nature, extent and scope of the WORK, which have been prepared or approved by CONSULTANT and are included and/or referred to in the Contract Documents. Shop Drawings are not Drawings as so defined.

1.24. **Effective Date of the Contract:** The date indicated in the Contract, but if no such date is indicated it means the date on which the Contract is signed by the last of the two parties to sign the Contract.

1.25. **Electronics Technicians:** Electronic Technicians help design, develop, test, manufacture, install, and repair electrical and electronic equipment.

1.26. **GEC:** Grounding electrode conductor: Conductor used to connect grounding electrode to equipment grounding conductor, or to grounded conductor of circuit at service equipment, or at source of separately derived system.



1.27.**GP:** Grounding electrode: Conductor (rod, pipe or plate or group of conductors) in direct contact with earth for purpose of providing low-impedance connection to earth.

1.28. **General Requirements:** See Special Conditions and Division 1 of the Technical Specifications.

1.29.**Handbox:** Rectangular or square underground pathway element similar to small maintenance hole, which cannot be fully entered, that allows for pulling point or splice point in power, security or communications pathway.

1.30.**Handhole:** A round underground pathway element similar to a handbox, which cannot be fully entered, that allows for a pulling point in a pathway

1.31.**ICP:** Inside Cable Plant - Part of Information Transport System running within buildings. ICP elements include workstation outlet assembly, cabling to the workstation from network rooms, backbone cabling within building, backbone cabling running between physically contiguous buildings, network racks and hardware (routers, switches, hubs, firewalls, etc.), patch panels, punch blocks, fiber distribution panels, patch cords, and cross-connect cables/wires.

1.32.**Identifier:** An item of information that links a specific element of the Information Transport System infrastructure with its corresponding record.

1.33.**Infrastructure (Information Transport System):** A collection of those Information Transport System components, excluding equipment, that together provides the basic support for the distribution of all information within a building or campus

1.34. **Irregular Bids:** Irregular Bids are defined as those containing serious omissions, unauthorized alternative Bids, incomplete Bids or unbalanced Bids.

1.35. **ITS:** Information Transport System: Copper cabling or optical fiber for transmission of information on School District property. Transmission includes data, video, voice, fire alarm, security, access control, and other low-voltage networks. Information Transport System is not limited to School District-owned cabling, but includes copper and optical fiber, and equipment owned by outside providers carrying School District's information. Pathways are not limited by School District's ownership, but include those owned by any third party. Information Transport System may be referred to as "the network" within project documents.

1.36.**Installer:** An installer can either install a new program on your computer or can update a program currently on your hard drive. Installer can also update or add files to your operating system, something installed, as machinery or apparatus placed in position or connected for use.

1.37.**Laws and Regulations:** Laws, rules, codes, regulations, ordinances and/or orders promulgated by a lawfully constituted body authorized to issue such Laws and Regulations.

1.38.**Linkage:** A connection between a record and an identifier or between records.

1.39.**Maintenance (man) holes:** Underground pathway element large enough for person to fully enter work, used to provide access to underground cable to pull, splice, and maintain.

1.40.**Maintenance** - A preventive or corrective action to maintain an existing public facility in an operational state or to preserve the facility from failure or decline.

1.41.**Media (Information Transport System):** Wire, cable, or conductors used for Information Transport System.

1.42. **Notice to Proceed:** The written notice issued by the District, or it's agents, to the Contractor authorizing the Contractor to proceed with the work and establishing the date of commencement of the Contract Time and the date the Contract WORK is to be completed.

1.43. **Notice of Tentative (or Intent) Award:** The official written notice by the DISTRICT to the apparent successful BIDDER giving authorization to enter into an agreement, stating that upon compliance and Board approval with the conditions precedent enumerated therein within the time specified, and receipt of accepted offer.

1.44.**OB:** Outlet box: Metallic or nonmetallic box used to hold Information Transport System outlets/connectors or transition devices

1.45.**OCP:** Outside Cable Plant: Part of Information Transport System running between buildings, from building to definable exterior point, between definable exterior points, or from non-School District source to School District building or definable exterior point. OCP includes termination punch blocks, fiber distribution panels, interior splices for outside to inside optical fiber transition, and other initial device into which outside cable attaches. OCP does not include backbone cable running between physically contiguous buildings unless cabling enters OSP pathway element (e.g. OSP conduits, maintenance holes, etc.). OCP includes underground cabling and aerial cabling.

1.46.**Outlet(Connector) (Information Transport System):** Connecting device in work area on which horizontal cable or outlet cable terminates

1.47.**Partial Utilization:** Placing a portion of the WORK in service for the purpose for which it is intended (or a related purpose) before reaching Substantial Completion for all the WORK.

1.48.**Pathway:** Facility for the placement of Information Transport System cable.

1.49. **Quality Control (QC)** is a process through which a business seeks to ensure that product quality is maintained or improved. Quality control involves testing units and determining if they are within the specifications for the final product.

1.50.**Repair:** A corrective action to restore by replacing a part or putting together what is torn or broken. Repair or maintenance includes activities that are necessarily incidental to repairing or maintaining the equipment.

1.51.**Record:** Collection of detailed information related to specific element of Information Transport System infrastructure.

1.52.**Renovate** - To restore to a former or better state; to make new or as if new again (as by cleaning, repairing, or rebuilding).

1.53.**Report:** Presentation of collection of information from various records.

1.54. **Resident Project Representative (RPR):** The authorized representative of the CONSULTANT who is assigned to the Site or any part thereof.

1.55. **Responsible Bidder, Offerer, Quoter, Or Respondent:** means an individual or business which has submitted a bid, offer, proposal, quotation, or response, which has the capability in all respects to perform fully the contract requirements, and the integrity and reliability which will give reasonable assurance of good faith and performance.



1.56. Responsive Bidder, Offerer, Quoter, Or Respondent, Vendor, Contractor means an individual or business which has submitted a bid, offer, proposal, quotation or response, which conforms in all material respects to the solicitation, including, but not limited to compliance with any M/WBE requirements contained within the solicitation.

1.57. Shop Drawings: All drawings, diagrams, illustrations, brochures, schedules and other data which are prepared by or for the CONTRACTOR, a Subcontractor, manufacturer, supplier or distributor and which illustrate the equipment, material or some portion of the Work and as required by the Contract Documents. Shop Drawings are not part of the Contract Documents and failure of the CONSULTANT or the COUNTY or any of his representatives to take exception to any product, material, system or installation depicted on Shop Drawings that are not in conformance with the requirements of the Contract Documents shall not constitute a Field Order or Change Order or any other Modification of the Contract Documents, and shall not relieve the CONTRACTOR from complying with any portion of the Contract Documents.

1.58. Safety Data Sheet: The manufacturer, importer, or distributor of a toxic substance will provide a safety data sheet with his/her offer.

1.59. Safety Precautions: The Contractor shall be responsible for the provision of adequate and proper safety precautions for the workmen and all persons in or around the work area.

1.60. Space (Information Transport System): Area used for housing installation and termination of Information Transport System equipment and cable, e.g., equipment rooms, network rooms, work areas, and maintenance holes/handboxes/handholes.

1.61. Special Conditions: When included as a part of the Contract Documents, Special Conditions refer only to the Work under this Contract. Special Conditions take precedent over the General Conditions.

1.62. Specialist: A person who concentrates primarily on a particular subject or activity; a person highly skilled in a specific and restricted field.

1.63. Specialty Contractor: A contractor whose scope of work and responsibility is limited to a particular phase of construction established in a category adopted by board rule and whose scope is limited to a subset of the activities described in one of the paragraphs of this subsection.

1.64. Specifications: Those portions of the Contract Documents consisting of written technical descriptions of materials, equipment, construction systems, standards and workmanship as applied to the WORK and certain administrative details applicable thereto.

1.65. Splice: Joining of conductors in splice closure, meant to be permanent.

1.66. Splice Box: Box, located in pathway run, intended to house cable splice.

1.67. Splice Closure: Device used to protect splice.

1.68. Standardization of Specifications: The process of establishing a single specification for an item, or range of items

1.69. Sub-Bidder: One who submits a Bid to a Bidder.

1.70. Subcontractor: An individual, firm, or corporation having a direct contract with the CONTRACTOR or with any other Subcontractor for the performance of a part of the WORK at the Site.

1.71. Substantial Completion: For purposes of this Contract, and for compliance of those procedures, duties and obligations as set forth in Florida Statutes §218.70 and §218.735, the term Substantial Completion shall be as follows, in lieu of any other definition:

- A. "Substantial Completion" is defined as that point where the District is able to enjoy beneficial occupancy of the Work and where the Work has achieved that level of completion such that District is able to utilize the entire Project for its intended purposes, including but not limited to the completion of all specified systems and items relating to life safety and regulatory use, with the exception of incidental or incomplete items except where a lack of completion of such incidental or incomplete items of Work shall adversely affect the complete operation of other areas of the Work.
- B. Additional conditions (if any) needed to achieve Substantial Completion of the Work and which are project specific are as set forth in attached Technical Specifications.
- C. When the entire Project is considered to be Substantially Complete, this does not constitute Final Acceptance or Final Completion of the entire Project.

1.72. Successful Bidder: The lowest, qualified, responsible and responsive Bidder to whom District (on basis of District's evaluation as hereinafter provided) makes an award.

1.73. Supplier: A manufacturer, fabricator, supplier, distributor, materialman or vendor.

1.74. Surety: The corporate body which is bound with the Contractor and which engages to be responsible for the Contractor and his acceptable performance of the Work.

1.75. Technical Specification: A subset of a design specification that establishes the material and operating requirements of a goods.

1.76. Technician: Worker in a field of technology who is proficient in the relevant skill and technique,^[1] with a relatively practical understanding of the theoretical principles

1.77. Termination position: Discrete element of termination hardware where information Transport System conductors are terminated.

1.78. Unbalanced Bids:

- A. **Mathematically Unbalanced Bid** means a bid containing lump sum or unit bid items which do not reflect reasonable actual costs plus a reasonable proportionate share of the bidder's anticipated profit, overhead costs, and other indirect costs.
- B. **Materially Unbalanced Bid** means a bid which generates a reasonable doubt that award to the bidder submitting a mathematically unbalanced bid will result in the lowest ultimate cost to the City; or which is so mathematically unbalanced as to result in an advance payment.

1.79. Underground Utility and Excavation Contractor: A contractor whose services are limited to the construction, installation, and repair, on public or private property, whether accomplished through open excavations or through other means, including, but not limited to, directional drilling, auger boring, jacking and boring, trenchless technologies, wet and dry taps, grouting, and slip lining, of main sanitary sewer collection systems, main water distribution systems, storm sewer collection systems, and the continuation of utility lines



from the main systems to a point of termination up to and including the meter location for the individual occupancy, sewer collection systems at property line on residential or single-occupancy commercial properties, or on multi-occupancy properties at manhole or wye lateral extended to an invert elevation as engineered to accommodate future building sewers, water distribution systems, or storm sewer collection systems at storm sewer structures. However, an underground utility and excavation contractor may install empty underground conduits in rights-of-way, easements, platted rights-of-way in new site development, and sleeves for parking lot crossings no smaller than 2 inches in diameter if each conduit system installed is designed by a licensed professional engineer or an authorized employee of a municipality, county, or public utility and the installation of such conduit does not include installation of any conductor wiring or connection to an energized electrical system. An underground utility and excavation contractor may not install piping that is an integral part of a fire protection system as defined in s. 633.021 beginning at the point where the piping is used exclusively for such system

1.80. Unit Price Work: WORK to be paid for on the basis of unit prices.

1.81. Utilities: All pipelines, conduits, ducts, cables, wires, manholes, vaults, tanks, tunnels or other such facilities or attachments, and any encasements containing such facilities which have been installed underground or above ground to furnish any of the following services or materials: electricity, gases, steam, liquid petroleum products, telephone or other communications, cable television, water supply or distribution, sewage and drainage removal, traffic or other control systems.

1.82. Work: Any and all obligations, duties and responsibilities necessary to the successful completion of the Project assigned to or undertaken by Contractor under the Contract Documents, including all labor, materials, equipment and other incidentals, and the furnished thereof.

1.83. Work Area (work station): Building space where occupants interact with Information Transport System terminal equipment

1.84. Work Change Directive: A written directive to Contractor, issued on or after the Effective Date of the Contract and signed by the District and recommended by the Consultant/EOR, ordering an addition, deletion or revision in the WORK, or which references an emergency or unforeseen physical conditions under which the WORK is to be performed. A Work Change Directive may not change the Contract Price or the Contract Time, but is evidence that the parties expect that the change directed or documented by a Work Change Directive shall be incorporated in a subsequently issued Change Order following negotiations by the parties as to its effect, if any, on the Contract Price or Contract Time.

1.85. Written Amendment: A written amendment of the Contract Documents, signed by the DISTRICT and CONTRACTOR on or after the Effective Date of the Contract and normally dealing with the non-engineering or non-technical rather than strictly WORK related aspects of the Contract Documents.

1.86. Intent of Certain Terms:

- A. Furnish, Install, Perform, Provide
 - 1) The word "furnish," when used in connection with services, materials, or equipment, shall mean to supply and deliver said services, materials, or equipment to the Site (or some other specified location) ready for use or installation and in usable or operable condition.
 - 2) The word "install," when used in connection with services, materials, or equipment, shall mean to put into

use or place in final position said services, materials, or equipment complete and ready for intended use.

- 3) The words "perform," or "provide," when used in connection with services, materials, or equipment, shall mean to furnish and install said services, materials or equipment complete and ready for intended use.
- B. When "furnish," "install," "perform," or "provide," is not used in connection with services, materials, or equipment in a context clearly requiring an obligation of contractor, "provide" is implied.
- C. Unless stated otherwise in the contract documents, words or phrases which have a well-known technical or construction industry or trade meaning are used in the contract documents in accordance with such recognized meaning.

1.87. Abbreviations, Acronyms, and Symbols:

Reference, Design Standards and Abbreviations: Any reference to published specifications or standards of any organization or association or as noted in Florida Building Code, Chapter 2, and Florida Fire Prevention Code are applicable; and shall comply with the requirements of the specification or standard which is current on the date of Advertisement for Bids. In case of a conflict between the referenced specifications or standards, the one having the more stringent requirements shall govern.

Documents listed shall be standard references currently in effect at project commencement.

In case of conflict between the referenced specifications or standards and the Contract Documents, the Contract Documents shall govern.

A. ABBREVIATIONS, REFERENCE STANDARDS, AND ACRONYMS

AA	Aluminum Association
AAA	American Arbitration Association
AABC	Associated Air Balance Council
AAMA	Architectural Aluminum Manufacturers Association
AASHO	American Association of State Highway Officials
ABA	American Bar Association
ABMA	American Boiler Manufacturers Association
ABPA	Acoustical and Board Products Association
ACI	American Concrete Institute
ACPA	American Concrete Pipe Association
ACR	Attenuation-to-Crosstalk Ratio
ADA	Americans with Disabilities Act
AEIC	Association of Edison Illuminating Companies
AFBMA	Anti-Friction Bearing Manufacturers Assoc.
AFF	Above finished floor
AGA	American Gas Association
AGC	Associated General Contractors of America
AGMA	American Gear Manufacturers Association
AHA	American Hardboard Association
AI	The Asphalt Institute
AIA	American Institute of Architects
AIA	American Insurance Association
AIMA	Acoustical and Insulating Materials Association
AISC	American Institute of Steel Construction
AISI	American Iron and Steel Institute
AITC	American Institute of Timber Construction
AMCA	Air Moving and Condition Association
ANSI	American National Standard Institute
ANSI/UL263	Fire Tests of Building Construction and Materials.
ANSI/UL723	Surface Burning Characteristics of Building Materials.
ANSI/UL1479	Fire Tests of Through Penetration Firestops.



ANSI/UL2079	Tests for Fire Resistance of Building Joint Systems.	ELFEXT	Equal Level Far-End Crosstalk
APA	American Plywood Association	EMC	Electromagnetic Compatibility.
API	American Petroleum Institute	EMI	Electromagnetic Interference.
APWA	American Public Works Association	EMT	Electrical metallic tubing.
AREA	American Railway Engineering Association	ENT	Electrical nonmetallic tubing.
ARI	American Refrigeration Institute	EPA	Environmental Protection Agency
ASA	American Standards Association (Now ANSI)	EPDM	Ethylene-polypropylene-diene membrane
ASAHC	American Society of Architectural Hardware Consultants	ER	Equipment Room. Replacing "TR"
ASCE	American Society of Civil Engineers	FCC	Federal Communications Commission
ASHRAE	American Society of Heating, Refrigerating and Air Conditioning Engineers	FCI	Fluid Control Institute
ASME	American Society of Mechanical Engineers	FD	Floor distributor (replacing network room, intermediate and horizontal cross-connect, and telecommunications as "building service" room identifiers). Also, Floor Drain as part of building plumbing system
ASSCBC	American Standard Safety Code for Building Construction	FDDI	Fiber Distribution Data Interface.
ASSHTO	American Association of State Highway Transportation Officials	FDER	Florida Department of Environmental Regulation
ASTM	American Society for Testing and Materials	FDOT	Florida Department of Transportation
ASTM/D16	Definitions of Terms Relating to Paint, Varnish, Lacquer, and Related Products for interpretation of terms used herein.	Fed Spec	Federal Specification
ASTM/D4442	Test Method for Moisture Content of Wood.	FEXT	Far-End Crosstalk
ASTM/E-84	Surface Burning Characteristics of Building Materials.	FMC	Flexible metallic conduit
ASTM/E119	Fire Tests of Building Construction & Materials	FOTP	Fiber Optic Test Procedure
ASTM/E814	Fire Tests of Through Penetration Fire Stops,	FPL	Florida Power and Light
ASTM/E1966	Test Method for Fire Resistive Joint Systems.	FPS	Feet Per Second
ASTM/E1399	Test Method for Cyclic Movement & Measuring Minimum & Maximum Joint Widths of Architectural Joint Systems	Freq	Frequency
AWG	American Wire Gauge	FS	Federal Standards
AWI	Architectural Woodwork Institute	GA	Gypsum Association
AWPA	American Wood Preservers Association	GE	Grounding Equalizer
AWPB	American Wood Preservers Bureau	Gnd	Ground
AWPI	American Wood Preserves Institute	GPM	Gallons Per Minute
AWS	American Welding Society	HB	Handbox. Also, hose bibb for water supply part of plumbing system.
AWWA	American Water Works Association	HC	Horizontal Cross-Connect (replaced by floor distributor "FD")
BHMA	Builders Hardware Manufacturers Association	HH	Handhole
BIA	Brick Institute of America (formerly SCPI)	HMI	Hoist Manufacturers Institute
BD	Building distributor (replacing main-cross connect and MDF as "building service" room identifiers).	HP	Horsepower
BICSI®	Building Industry Consulting Service International, Inc.	HSBII	Hartford Steam Boiler Inspection and Insurance Co.
BTU	British Thermal Unit.	HVAC	Heating, Ventilation, and Air Conditioning
CATV	Community Antenna Television (cable television).	Hz	Hertz
CD	Campus distributor (replacing main-cross connect and MDF as "campus-wide service" room identifiers). Also, compact disk for storage of audio or video information.	IC	Intermediate Cross-Connect (replaced by building distributor "BD").
dB	Decibel.	ID	Inside Diameter
CDA	Copper Development Association	IDC	Insulation Displacement Connectors
CFS	Cubic Feet Per Second	IEEE	Institute of Electrical and Electronic Engineers
CMAA	Crane Manufacturers Association of America	IFI	Industrial Fasteners Institute
CRSI	Concrete Reinforcing Steel Institute	IMC	Intermediate metal conduit
CS	Commercial Standard	IPCEA	Insulated Power Cable Engineers Association
DHI	Door and Hardware Institute	IPS	Iron Pipe Size
DIPRA	Ductile Iron Pipe Association	ISO	International Organization for Standardization
DOT Spec	Standard Specification for Road and Bridge Construction Florida Department of Transportation, 1982	ISP	Inside Cable Plant
E/A	Engineer and/or Architect	LFMC	Liquidtight flexible metal conduit
EDA	Economic Development Association	LFNC	Liquidtight flexible nonmetallic conduit
EEL	Edison Electric Institute	Mbps	Megabits per second.
EF	Entrance Facility	MER	Main Equipment Room
EIA	Electronic Industries Alliance	MF	Factory Mutual System
		MGD	Million Gallons Per Day
		MH	Maintenance Hole
		MHI	Materials Handling Institute
		MIL	Military Specification
		MMA	Monorail Manufacturers Association
		MHz	Megahertz
		NBFU	National Board of Fire Underwriters
		NBHA	National Builders' Hardware Association
		NBR	Acrylonitrile-butadiene rubber
		NBS	National Bureau of Standards
		NCSA	National Crushed Stone Association
		NCSPA	National Corrugated Steel Pipe Assoc
		NEC	National Electrical Code
		NECA	National Electrical Contractors' Assoc



NEMA	National Electrical Manufacturers' Association
NESC	National Electric Safety Code, C2-1997.
NFPA	National Fire Protection Association
NLA	National Lime Association
NPC	National Plumbing Code
NPT	National Pipe Threads
NR	Network Room
NRTL	National Recognized Testing Laboratory
NSC	National Safety Council
NSF	National Sanitation Foundation
OD	Outside Diameter
OSHA	U.S. Department of Labor, Occupational Safety and Health Administration
OCP	Outside Cable Plant.
OTDR	Optical Time Domain Reflectometer
PCA	Portland Cement Association
PCI	Prestressed Concrete Institute
PR	Pair
PS	United States Products Standards
PSI	Pounds per Square Inch
PSIA	Pounds per Square Inch Atmosphere
PSIG	Pounds Per Square Inch Gauge
RCDD® :	Registered Communications Distribution Designer
RPM	Revolutions Per Minute
RFI:	Radio Frequency Interference
RH	Relative Humidity.
RNC	Rigid nonmetallic conduit.
SAE	Society of Automotive Engineers
SDI	Steel Decks Institute
SIGMA	Sealed Insulating Glass Manufacturer's Association
SJI	Steel Joists Institute
SMACNA	Sheet Metal and Air Conditioning Contractors' National Association
SM	Single Mode
SSI	Scaffolding and Shoring Institute
SSPC	Steel Structures Painting Council
SSPC	Structural Steel Painting Council
STA	Station (100 feet)
TAS	Technical Aid Series
TBB	Telecommunication Bonding Backbone
TCA	Tile Council America
TDH	Total Dynamic Head
TE	Telephone Equipment (Wall Mounted Equipment Rack)
TGB	Telecommunications Grounding Buss Bar
TH	Total Head
TIA	Telecommunications Industry Association.
TMGB	Telecommunications Main Grounding Buss Bar
UBC	Uniform Building Code
UL	Underwriter's Laboratories, Inc.
UOM	Units of Measure-Weights and Measures shall be as identified by Weights and Measures Division, NIST, U. S. Department of Commerce, 100 Bureau Dr., Stop 2600, Gaithersburg, MD 20899-2600.
UPS	Uninterruptible Power Supply
USASI	United States of American Standards Institute
WAO	Work Area Outlet

ANSI/TIA/EIA-568-B.1 and addenda "Commercial Building, Telecommunications Cabling Standard - Part 1: General Requirements".

ANSI/TIA/EIA-568-B.2 and addenda "Commercial Building Telecommunications Cabling Standard - Part 2: Balanced Twisted-Pair".

ANSI/TIA/EIA-568-B.3 and addenda "Commercial Building Telecommunications Cabling Standard - Part 3: Optical Fiber Cabling and Components Standard".

ANSI/TIA/EIA-569-B and Addenda "Commercial Building Standard for Telecommunications Pathways and Spaces".

ANSI/TIA/EIA-606-A and Addenda "Administration Standard for Telecommunications Infrastructure of Commercial Buildings".

ANSI-J-STD-607-A and Addenda "Commercial Building Grounding (Earthing) and Bonding Requirements for Telecommunications".

ANSI/TIA/EIA-526-7 and Addenda "Measurement of Optical Power Loss of Installed Single-Mode Fiber Cable Plant".

ANSI/TIA/EIA-526-14A and Addenda "Optical Power Loss Measurements of Installed Multimode Fiber Cable Plant".

ANSI/TIA/EIA-758 "Customer Owned Outside Plant Telecommunications Cabling Standard".

IEC/TR3 61000-5-2 - Ed. 1.0 and amendments. "Electromagnetic compatibility (EMC) - Part 5: Installation and mitigation guidelines – Section Earthing and cabling".

ANSI/NFPA 70 National Electrical Code, 2008 Edition.

BICSI Telecommunications Distribution Methods Manual (TDMM).

BICSI Telecommunications Cabling Installation Manual (TCIM).

BICSI Customer-Owned Outside Plant Design Manual, 3rd, Edition (CO-OSP).

Applicable Martin County Codes and Regulations.

Underwriters Laboratories (UL).

FCC -Federal Communications Commission.

Occupational Safety and Health Regulations (OSHA).

Florida Fire Protection Code (including NFPA 101 Life Safety Code).

Applicable Florida Statutes and Administrative Rules.

Manufacturers Training Manuals (Design and Installation).

NACE (National Association of Corrosion Engineers) - Industrial Maintenance Painting.

NPCA (National Paint and Coatings Association) - Guide to U.S. Government Paint Specifications.

PDCA (Painting and Decorating Contractors of America) - Painting - Architectural Specifications Manual.

SSPC (Steel Structures Painting Council) - Steel Structures Painting Manual.

- o SSPC-SP 1 – Solvent Cleaning.
- o SSPC-SP 2 – Hand Tool Cleaning.
- o SSPC-SP 3 – Power Tool Cleaning.
- o SSPC-SP 13 – Nace No 6 Surface Preparation for Concrete.

UL Underwriters Laboratories Fire Resistance Directory.

Note: Additional abbreviations and symbols are shown on the Drawings.

B. ITS/WARNOCK-HERSEY - PRODUCT DIRECTORY

NFPA 101: Life Safety Code - National Fire Protection Association (NFPA).

NFPA 70: National Electrical Code - National Fire Protection Association (NFPA).

ANSI/NECA/BICSI-568-2001 "Installing Commercial Building Telecommunications Cabling".



SECTION II
INSTRUCTIONS TO BIDDERS

1. REQUIREMENTS FOR PERSONNEL ENTERING DISTRICT

PROPERTY: Possession of firearms will not be tolerated in or near school buildings. Nor will violations of Federal or State Laws and any applicable District policy regarding Drug Free Workplace be tolerated. Violators shall be subject to immediate termination. "Firearm" means any weapon (including a starter gun or antique firearm) which will, is designed to, or may readily be converted to expel a projectile by the action of an explosive; the frame or receiver of any such weapon; any destructive device; or any machine gun.

No person who has a firearm in their vehicle may park their vehicle on District property. Furthermore, no person may possess or bring a firearm on District property.

If any employee of an awarded Proposer or subcontractor is found to have a firearm on District property, said employee shall be terminated from the project. If the awarded Proposer or subcontractor fails to ensure that said employee is restricted from the project may result in contract cancellation and/or termination.

Proposers are advised that they are responsible to ensure that no employee, agent or representative of their company who has been convicted or who is currently under investigation for a crime against children in accordance with section 435.04, Florida Statutes shall enter any school site.

Possession/use and/or being under the influence of any illegal mind-altering substances, such as, but not limited to alcohol and/or substances delineated in Chapter 893, Florida Statutes, by Contractors' employees/independent Contractors or its Subcontractors' employees/independent Contractors will not be tolerated on School Board property. If any employee/independent Contractor is found to have brought and/or used or is under the influence of any illegal mind-altering substances as described above on School Board property, said employee/independent contractor shall be removed and terminated from the project by the Contractor. If a Subcontractor fails to terminate said employee/independent Contractor, the Contractor shall terminate its agreement with the Subcontractor for the project. If the Contractor fails to terminate said employee/independent Contractor or fails to terminate the agreement with the Subcontractor who fails to terminate said employee/independent Contractor, this Contract may be terminated by the School Board.

2. FINGERPRINTING, JESSICA LUNSFORD ACT:

Contractor, his subcontractors, vendors and suppliers who are to be permitted access to school grounds while students are present, or have direct contact with students or have access to or control of school funds shall obtain Level 2 background screening in accord with Florida Statute FS1012.465 – Jessica Lunsford Act.

- 2.1 Level 2 screening excludes personnel working on school district property where students are present who have criminal records that include sexual offender, sexual misconduct with developmentally disabled or mental health patients, terrorism, murder, kidnapping, lewd, lascivious or indecent acts or exposure, incest, child abuse or neglect.
- 2.2 Persons screened as noted above with other types of criminal history may be allowed on school grounds provided under following conditions:
- 2.3 Contractor, subcontractors, vendors and suppliers shall be under continuous direct supervision of school district employee or Level 2 screened and cleared employee as noted above.
- 2.4 Contractor, subcontractors, vendors and suppliers may be allowed on student occupied site if area of construction is isolated from students by continuous six foot high chain link fence separating work area and school.

- 2.5 Persons with current Level 2 clearance who are subsequently arrested for disqualifying offenses shall be disqualified from access to school sites and shall immediately surrender their Photo ID Badge to their employer who shall be responsible for returning badge to Martin County School District's Department of Human Resources within 48 hours of arrest or notice of arrest or criminal offense.
- 2.6 Persons failing to notify their employer and Martin County School District's Department of Human Resources within 48 hours of arrest will be charged with 3rd degree felony, punishable by up to five years imprisonment and \$1,000 fine.
- 2.7 Employers of persons having been arrested for disqualifying offenses who subsequently allows said employee to continue working on school property may also be charged with 3rd degree felony, punishable by up to five years imprisonment and \$1,000 fine.
- 2.8 Contractor, his subcontractors, vendors and suppliers working on school board sites shall be fingerprinted and obtain work badges.
- 2.9 Questions regarding fingerprinting or identification badge processing may be directed to District Personnel Department at (772)219-1255, Ext. 30296.
- 2.10 The fingerprint screening must be completed in advance of the awarded Bidder providing any services. The awarded Proposer shall bear the cost of acquiring the background screening required by Fla. Stat. 1012.32, and any fee imposed by the Florida Department of Law Enforcement to maintain the fingerprints provided with respect to the awarded Bidder and its employees. Awarded Bidder shall provide District with a list of its employees. Awarded Bidder shall update these lists in the event that any new employees are added and awarded Bidder agrees that new employees shall be fingerprinted. Awarded Bidder agrees that in the event any employee is convicted of a criminal offense, the awarded Bidder shall notify the District within forty-eight (48) hours.
- 2.11 The parties agree in the event that the awarded Bidder fails to perform any of the duties described in the above paragraph, this shall constitute a breach of the contract entitling the District to terminate immediately with no further responsibility to make payment or perform any other duties under this contract. Awarded Bidder agrees to indemnify and hold harmless the District, its officers and employees from any liability whatsoever resulting from awarded Bidder's failure to comply with the requirements of this paragraph or Fla. Stat. 1012.32 and 1012.465.

3. QUALIFICATIONS OF BIDDERS:

To demonstrate qualifications to perform the Work, each Bidder must be prepared to submit within five (5) calendar days of District's request written evidence acceptable to the District documentary evidence demonstrating, financial data/fiscal responsibilities, previous experience, present commitments and other such data as may be called for to meet all of the Bidder's obligations set forth in the Bid documents. Each Bid must contain evidence of Bidder's qualifications to do business in the State of Florida or obtain such qualification prior to award of the contract.

The District reserves the right to contact any of the firms listed by Bidders in any sections as references or any additional firms or individuals to review Bidder's qualifications. Bids that do not comply with these requirements may be rejected at the option of the District.

The project shall be constructed by a firm with the primary qualifying agent licensed as a Contractor pursuant to and as



defined by Florida Statute 489, and shall have been employed full time by the construction firm for at least one year prior to this project's bid date.

4. **ANNUAL APPROPRIATION:** This Bid is conditional upon the District having funding to implement the Contract.
5. **DEFINED TERMS:** Terms used in these Instructions to Bidders, have the meanings assigned to them in the Industry involved in the subject matter of the Bid, in the Martin County School District, Standard General Conditions of the Construction Contract.
6. **COST OF BID:** Costs, either direct or indirect, incurred by the Bidder in the preparation, presentation, demonstration, delivery or for any other reason associated with the submittal of this bid is solely the responsibility of the Bidder and not the District, and are not to be charged to the District.
7. **BACKGROUND INVESTIGATION:** As a part of the Bid evaluation process, the District may conduct a background investigation, including a criminal record check of Bidder's officers and/or employees, by the Sheriff's Office to establish the competency, responsibility, qualifications and financial ability of the Bidders, proposed subcontractors and other persons and organizations to do the work in accordance with the Contract Documents to the District's satisfaction within the prescribed time. The Board reserves the right to reject the Bid of any Bidder who does not pass any such evaluation to the District's satisfaction.

The Bidder's signature on the Bid Form constitutes acknowledgement of and consent to such investigation. The District shall be the sole judge in determining the Bidder's qualifications.

8. **FACILITIES:** The District reserves the right to inspect the Bidder's facilities at any reasonable time, prior to award of the Bid, during normal working hours, with prior notice to determine that it has a bona fide place of business, and is a responsible Bidder.

The District also reserves the right to inspect all facilities of any subcontractor in order to make determination as to the foregoing. The subcontractor shall be equally responsible for meeting all requirements specified in the Invitation to Bid.

9. **INQUIRIES/AVAILABILITY:** Inquiries concerning this ITB should be made in writing. The District will respond to written inquiries, if received at least seven (7) calendar days prior to the date scheduled for opening the bids. The District shall record its responses to inquiries and any supplemental instructions in the form of a written addendum. If addenda are issued, the District shall make every attempt to issue such addenda at least seven (7) calendar days before the date fixed for receiving the proposals. **Written addenda shall be disseminated via the Vendor Registry and DemandStar. No interpretation shall be considered binding unless provided in writing to the Martin County School District Purchasing Department. It is the sole responsibility of the Bidder to ensure all addenda are received.**

CONTACT WITH MARTIN COUNTY SCHOOL DISTRICT PERSONNEL OTHER THAN PURCHASING STAFF OR A DESIGNATED REPRESENTATIVE REGARDING THIS INVITATION TO BID SHALL BE GROUNDS FOR ELIMINATION FROM THE PROCESS.

10. **INTERPRETATIONS AND ADDENDA:** All Bidders shall carefully examine the Bid Documents. Any ambiguities or inconsistencies should be brought to the attention of the Purchasing Department through written communication prior to opening of the bids. Failure to do so on the part of the Bidder shall constitute an acceptance by the Bidder of any subsequent decision by the District. MCSD will receive written requests for clarification

concerning the meaning or interpretation of this ITB by issuance of addenda via DemandStar and Vendor Registry, until (7) days prior to the bid opening date. Questions shall be emailed to bids@martinschools.org with reference to the ITB number in the subject for faster recognition only questions answered by formal written Addenda issued by the MCSD Purchasing Department shall be binding. Oral and other interpretations or clarifications shall be without legal effect.

It is the sole responsibility of the Bidder to ascertain whether any addenda to this Invitation to Bid has been issued, and to submit all such addenda properly acknowledged with the Bid response.

The District may delay scheduled due dates if it is to the advantage of the District. The District shall notify Bidders of all changes in scheduled due dates by written addenda.

11. **BID DOCUMENTS:** Solicitation Documents may be obtained by registering with DemandStar in order to receive all required documents and notification of addenda. Register for FREE at <http://www.demandstar.com/subscriptions> "FREE AGENCY", toll-free 1-800-711-1712, or from Vendor Registry at www.vendorregistry.com. Bidders who obtain solicitation documents from any other source are cautioned that the solicitation package may be incomplete.

Complete sets of Bid Documents shall be used in preparing Bids. Neither District nor EOR assumes and each disclaims any responsibility for errors or misinterpretations resulting from the use of incomplete sets of Bid Documents.

District and EOR in making copies of Bid Documents available on the above terms do so only for the purpose of obtaining bids on the Work and do not confer a license or grant for any other use.

12. **UNIT PRICES:** Where a discrepancy between unit price and total price is indicated on a Bidder's submitted Schedule of ITB Prices or Bid Forms, the unit prices shall prevail.
13. **IRREGULARITIES:** Bids not meeting stated minimum terms and qualifications may be rejected by the District as non-responsive or irregular. However, the District reserves the right to waive any irregularities, technicalities or informalities in any bid. The District reserves the right to allow for the clarification of questionable entries and for the correction of typographical and mathematical errors.
14. **BID SUBMISSION:** Bidder should submit their bid indicating their name and Project Name, ITB Number, and time and date of the ITB opening. The submission of bids shall be submitted electronically through www.DemandStar.com or bids@martinschools.org by Bidders responding to this ITB no later than the designated deadline date and time. A Bidder's failure to submit as required before the deadline shall cause their bid submittal to be disqualified. Late bids will be retained unopened.

14.1 All submittals must be compatible with Microsoft Office or Portable Document Format (PDF). The Bidder can only view/submit his/her Electronic Submittal and will not have access to any other Bidder's submittals. The Bidder's Electronic Submittal may be changed at the Bidder's discretion until the ITB Due Date and Time is reached. The Bidder will no longer be allowed to change or have access to the electronic submittal after the ITB Due Date and Time as the District will open all bids on said date. Any Bidder who is submitting an Electronic Submittal for the first time is strongly encouraged to contact DemandStar by e-mailing questions to demandstar@demandstar.com.

14.2 Submit the entire Bid Package by completing and returning all required documents. All submittals are required to be electronic and be contained in one (1) file. No hard copies will be accepted.



- 14.3 Bids, once opened, become the property of the District and shall not be returned to the Bidders. Upon opening, bids become "public records" and shall be subject to public disclosure in accordance with Chapter 119, Florida Statutes.
- 14.4 Offers by facsimile, telegram, or telephone are **not** acceptable. All Bidders and their representatives are invited to attend. Bid tabulations are posted online at www.demandstar.com or www.vendorregistry.com.
- 14.5 Bids will be opened and read aloud publicly at the time and place indicated in the Invitation to Bid. Submittal of a Bid in response to this Invitation to Bid constitutes an offer by the Bidder
- 14.6 Should there be a tie on either the unit price (if awarded on a per item basis), sections of the solicitation (i.e.: building contracts, or solicitations awarded by section) or the whole solicitation ("all or none" solicitations or service solicitations), the deadlock will be decided upon using the following order:
- Companies who certify they are a drug-free workplace.
 - Companies located in Martin County, Florida.
 - Companies located in Florida.
 - The company receiving the larger dollar award on other items within the solicitation.
 - All else being equal, a coin toss will be made to decide the award.
- This does not preclude the possibility of splitting an order if it is in the best interest of the School Board.
- 14.7 All Bids shall remain subject to acceptance for ninety (90) calendar days after the day of the Bid opening, but the District may, at the sole discretion of the District, release any Bid and return the Bid Security prior to that date.
- 14.8 It is the sole responsibility of the Bidder to assure that his or her submittal is uploaded to DemandStar or bids@martinschools.org on or before the ITB Due Date and Time. The District shall in no way whatsoever be responsible for any delays caused by any power outages or internet failures. No exceptions will be made.

15. **MODIFICATION OF BIDS:** Bids may only be modified, by an appropriate document duly executed, prior to the solicitation closing date and time. The Bidder must present certification to assure that they are indeed an authorized representative of the Bidder's firm at the time modification to the Bid is presented.
16. **BID FORMS:** Bids must be submitted on the prescribed forms Section VII; all blank spaces must be filled in as noted, in ink or typed with amounts extended and totaled. Where indicated on the Bid Form, items shall be stated in numbers. Bidders are required to bid all items to be considered. Bidder should not reference the words "No charge, N/A, included, etc." on any of the line items. Vendor must identify a monetary amount for each line item. If vendor is not providing a bid price for an item, zero (0) must be designated on that line item. Failure to identify a monetary amount for each item may cause Bidder's bid response to be considered non-responsive and rejected.

The District reserves the right to accept any Bid or combination of Bid alternates, reject any and all Bids, waive any and all informalities, minor irregularities, to accept any item or group of items unless qualified by Bidder; to acquire additional quantities at prices quoted on the Invitation to Bid unless additional quantities are not acceptable, in which case the bid sheets must be noted "BID IS FOR SPECIFIED QUANTITY ONLY, and the right to disregard all nonconforming, non-responsive, unbalanced or conditional Bids or counter-proposals. In addition, the District reserves the right to make a multiple award if it is in the best interest of the District.

Failure to provide all of the information required to accompany the Bid, Bid Form and Specifications shall be considered a serious omission, which may result in the bid being rejected as non-conforming.

The Bid shall contain acknowledgment of receipt of all addenda (copies of which shall be attached to the Bid Form).

17. **BID TABULATION:** Bid tabulations shall be posted on www.DemandStar.com and Vendor Registry within ten (10) days after the bid opening.
18. **EVALUATION FACTORS:** The District reserves the right to reject the Bid of a non-responsible Bidder that the District determines is of doubtful financial ability or fails to meet any other pertinent standard or criteria established by the District. Further, A Bidder must be, at the time of the Bid opening, a fully authorized agent or representative of the product or service Bid, and capable of producing, providing or installing the items Bid, and so certify upon request.

The District shall consider the firms qualifications, compliance of requirements, and time of completion as evaluation factors. In addition, the District may require the apparent successful Bidder to submit a Schedule of Values priced in line item format including time frames (not dated) for staff to review prior to staff's actual award recommendation being submitted to the District Board.

Any inconsistencies shall be brought to the attention of the intended awardee for adjustment prior to award and acceptance of said schedule. An unbalanced Schedule of Values may result in rejection of the bid as non-responsible. Failure to produce said Schedule of Values within four (4) business days of the District's request may result in the bid being rejected as non-responsive.

The District may consider the qualifications and experience of subcontractors and other persons and organizations (including those who are to furnish the principal items or material, services, or equipment) proposed for those portions of the work as to which the identity of subcontractors and other persons and organizations must be submitted.

The District may also consider the operating costs, maintenance requirements, performance data and guarantees of major items of materials and equipment proposed for incorporation in the Work when such data is required to be submitted prior to the Notice of Tentative Award.

19. **AWARD OF CONTRACT:** The District reserves the right to award item by item, and/or group by group or on an all or none basis to the lowest responsive, responsible Bidder that provides the best value to the District.

NO AWARD RECOMMENDATION SHALL BE BROUGHT BEFORE THE BOARD FOR CONSIDERATION TO AWARD UNTIL THE CONTRACTOR/BIDDER HAS PRESENTED A SIGNED ORIGINAL OF THE CONTRACT OR PURCHASE ORDER ALONG WITH ANY OTHER REQUIRED DOCUMENTS TO THE PURCHASING DEPARTMENT.

NO AWARD SHALL BE DEEMED FINAL AND SHALL BE DEEMED CONDITIONAL, UNTIL THE PARTIES HAVE FULLY EXECUTED THE AGREEMENT(S) OR A PURCHASE ORDER HAS BEEN ISSUED BY THE BOARD TO THE BIDDER. THE BOARD RESERVES THE RIGHT TO REVOKE ANY AWARD MADE HEREUNDER, WITHOUT PENALTY, PREMIUM OR OBLIGATION, AT ANY TIME PRIOR TO THE DELIVERY OF THE FULLY EXECUTED AGREEMENT(S) OR PURCHASE ORDER. NO BIDDER SHALL BE ENTITLED TO RELY ON ANY ANNOUNCEMENT OF AN AWARD, AND THE BOARD SHALL IN NO WAY BE ESTOPED IN THE REVOCATION OF AN AWARD PREVIOUSLY GRANTED.

Section 119.071(1)(b)2., F.S., provides an exemption for "sealed bids, proposals, or replies received by an agency pursuant to a competitive solicitation" until such time as the agency provides notice of an intended decision or until 30 days after opening "the bids, proposals, or final replies," whichever is earlier.



20. **DIRECT MATERIAL PURCHASES:** The District reserves the right to issue purchase orders for materials to either the Contractor's or the District's suppliers for construction related materials.

21. **CONTRACTUAL AGREEMENT:** The submission of your Bid constitutes a firm offer by the Bidder. Upon acceptance by the Board, the Purchasing Department shall issue a notice of award and purchase order(s) and/ or contract for any supplies, equipment and/or services as a result of this bid. The Invitation to Bid and the corresponding purchase order(s) and /or contract shall constitute the complete agreement between the successful Bidder and the Board. Unless otherwise stipulated in the bid documents or agreed to in writing by both parties, no other contract documents shall be issued or accepted.

The District may attach as a part of this solicitation, a Sample Contract document. Bidders shall be responsible for complying with all of the terms and conditions of the Sample Contract document, except where variant or conflicting language may be included in any Special Conditions contained herein. Bidders shall note any deviation or variance with the Sample Contract document at the time of bid submission. Should no revisions be noted, the District will assume and the Contractor agrees that the terms and conditions of agreement are acceptable.

22. **CONTRACT TERMS:**

- a. A contract resulting from this document shall be governed in all respects as to validity, construction, capacity, performance, or otherwise by the laws of the State of Florida.
- b. Contractors providing service under this contract assure the School Board that they are conforming to and otherwise complying with the following, as applicable:
 - The Civil Rights Act of 1964, as amended.
 - Clean Air and Water Pollution Acts, 42 U.S.C. 7401-7671q.
 - Federal Water Pollution Control Act, 33 U.S.C. 1251-1387.
 - Executive Order 11738.
 - EPA Regulation, 40 CFR Part 15, which prohibits the use under non-exempt federal contracts, grants or loans of facilities included on the EPA list of violating facilities.
 - Federal, state and local laws and regulations, including the Davis-Bacon Act, pertaining to wages, hours and conditions of employment and 2CFR 200.317 – 200.326, if applicable.
 - Energy Policy and Conservation Act, 42 U.S.C. 6201.
 - Funding Agreement (Rights to Inventions) 37 CFR Part 401.
 - Recovered Materials Section 6002 of Environmental Protection Agency (EPA) at 40 CFR Part 247.
 - Equal Employment Opportunity, 41 CFR Part 60.
 - Copeland "Anti-Kickback" Act, 40 U.S.C. 3145, as supplemented by the Department of Labor Regulations (29 CFR Part 3, "Contractors and Subcontractors on Public Building or Public Work Financed in Whole or in Part by loans or grants from the United States".)
 - Contract Work Hours and Safety Standards Act, 40 USC 3702 and 3704, as supplemented by Department of Labor Regulations (29 CFR Part 5), as applicable.

23. **SIGNING OF CONTRACT:** The Notice of Tentative Award will be presented to the Successful Bidder. The Legal Department shall issue the contract within ten (10) calendar days thereafter, the Successful Bidder shall sign and deliver the required number of counterparts of the Construction Contract to District. Upon Board approval, the District shall request the required bonds and

insurance certificates. The aforementioned documents must be submitted to the District prior to any WORK being performed. After receipt of requested documents, the executed contract, purchase order, and notice to proceed will be presented to the Awarded Bidder. Each counterpart is to be accompanied by a complete set of the Drawings. By signing this contract, the Contractor certifies that it is in compliance with, and/or will comply with, the aforementioned terms specifically mentioned, as well as all other municipal, county, state and federal requirements and regulations.

24. **CONTRACT DEFAULT:** In the event the Contractor fails to enter into a contract with the School Board on the basis of the submittal, such action shall constitute a default of this agreement. Further default may be declared by the School Board if the Contractor violates the terms of the submitted document in any manner. Upon default of this agreement and/or any agreement resulting from this agreement, the School Board shall be entitled to pursue all remedies available at law and/or in equity, including, but not limited to, the recovery of damages equaling the difference of the submitted price and the price the School Board subsequently pays to secure performance from other sources. Damages may be assessed and deducted against any funds due and owing to the Contractor.

In the event any litigation occurs between the parties as a result of the contract, the prevailing party shall be entitled to recover reasonable attorney's fees and court costs for any such action.

At the discretion of the School Board, any Contractor found in default of this agreement and/or any agreement resulting from this agreement, shall be removed from the Contractor list for a period of up to three (3) years from the date of said default. Default under this agreement and/or any other agreement(s) in which the School Board has contracted with the Contractor, may also, at the discretion of the School Board, result in termination of any other such agreement(s).

25. **TERMINATION CLAUSES:** This contract may be terminated without liability to the School Board in whole or in part when it is deemed to be in the best interest of the School Board to so act. Notification of termination must be in writing. The Contractor shall have a period of time, as determined by the School Board, to remedy any noncompliance to offered terms and specifications. The School Board, upon termination, shall exercise its discretion to complete the balance of the contract consistent with the best interest of the School Board. The School Board delegates the authority to terminate the contract to the Superintendent or designee. At the discretion of the School Board, the Contractor may be removed from future solicitation opportunities for a period up to three (3) years.

A. The Contract may be terminated as follows:

- by the District, at its convenience pursuant to paragraph B, below;
- By the District for Contractor's failure to adequately perform the Contract, pursuant to paragraph C, below;
- By the mutual Contract of the parties; or as may otherwise be provided below.
- In the event of the termination of the Contract, any liability of one party to the other arising out of any Services rendered, or for any act or event occurring prior to the termination, shall not be terminated or released.

B. **Termination for District's Convenience:** The District, by written notice, shall have the right to terminate and cancel the Contract, without the Contractor being at fault, for any cause or for its own convenience, and require the Contractor



to immediately stop work. In such event, the District shall pay the Contractor for the work actually performed. The District shall not be liable to the Contractor for any other costs, charges, or expenses, including but not limited to, prospective profits and overhead on work not performed.

C. Termination for Contractor's Failure to Perform: In addition to any other termination provisions that may be provided in the Contract, the District may terminate the Contract in whole or in part if the Contractor makes a false Invoice or fails to perform any obligation under the Contract and does not remedy the failure within ten (10) calendar days after receipt by the Contractor of written demand from the District to do so, unless, however, the nature of the failure is such that it cannot, in the exercise of reasonable diligence, be remedied within ten (10) calendar days, in which case the Contractor shall have such time as is reasonably necessary to remedy the failure. In the event that the awarded bidder abandons this Contract or causes it to be terminated, awarded bidder shall indemnify the District against loss pertaining to this termination.

D. Default: In case of default by the Bidder, the Board may procure the articles or services from other sources and hold the Bidder responsible for any excess costs incurred thereby.

E. Payment upon Termination: Upon termination of the Contract, the District shall pay the Contractor for those Services actually rendered and contracted for under the Contract, and those reasonable and provable expenses required and actually incurred by the Contractor for Services prior to the effective date of termination. Where the Contract is terminated for cause by the District, such payment shall be reduced by an amount equal to any reasonable and provable expenses actual incurred by the District as a direct result of the termination.

26. **REJECTION / DISQUALIFICATION OF BIDDER:** The Board, at its sole discretion, reserves the right to reject any and all bids, accept any bid or any combination of bids or waive any minor irregularity or technicality in bids received, when in its sole judgment, it shall best serve public interest. The right is reserved to reject any and all Bids or to accept the one deemed by the DISTRICT to be the most advantageous. Contractor's bid shall be rejected as non-responsive if any of the following exist (this list is not all inclusive):

- More than one Bid from an individual, firm, partnership, corporation, or association under the same or different names shall not be considered.
- The District reserves the right to reject the bid of any Bidder in arrears or in default upon any debt or contract to the District or who have failed to perform faithfully any previous contract with the District or with other governmental jurisdictions.
- If there is reason to believe that collusion exists between Bidders.
- Bids that are judged to be mathematically or materially unbalanced shall be rejected.
- The Bid Package is found to have concealed or contained false and/or misleading information.
- Executed requested Attachments/Affidavits are not completed or submitted.
- Incomplete execution of documents, Bidder signature page, and Bid submittal form.

- Not licensed to perform the required work or provide the required product.
- Not eligible to bid due to violations listed under, Public Entity Crimes.
- Submission of an irregular bids. Failure to fill out forms completely, indicating compliance or deviation for each item may be used as reason for rejection.
- Non-compliance with applicable laws or contains any unauthorized additions or deletions or contains irregularities of any kind is considered incomplete, indefinite, or ambiguous as to its meaning.

27. **EXECUTION OF BID:** Bidders shall submit their bid response electronically as described above. For this purpose, all references herein to signing requirements or other required acknowledgments hereby include either a manual signature in blue ink or by electronic digital signature by an authorized officer of the proposing firm who is legally authorized to enter into a contractual relationship in the name of the Bidder. Bid must be typed or legibly printed in ink. Use of erasable ink is not permitted. All corrections made by Bidder to any part of the Bid document must be initialed in ink. The respondent agrees that the action of electronically submitting its response constitutes the following:

- An electronic signature on the responses.
- An electronic signature on any form or section specifically calling for a signature and
- An affirmative agreement to any statement contained in the solicitation that requires a definite confirmation or acknowledgement.
- Compliance to electronic signatures as specified in F.S. Chapter 668.

The bid submittal of a Statement of Bid by the Bidder shall be considered by the District as constituting an Offer by the Bidder to perform the required services.

Bids by corporations must be executed in the corporate name by the President or Vice President (or other corporate officer accompanied by evidence of authority to sign) and the corporate seal shall be affixed and attested by the Secretary or Assistant Secretary. The corporate address and State of Incorporation shall be shown below the signature.

Bids by partnership must be executed in the partnership name and signed by a general partner, his title must appear under his signature and the official address of the partnership must be shown below the signature.

All names of persons signing documents must be typed or printed below the signature.

28. **NO BID:** If not submitting a Bid, please respond no later than the Bid opening date and time, by returning the acknowledgment, noting the reason for declining. An addendum may be issued to remedy providing the circumstances are determined reasonable.

29. **WITHDRAWAL OF BIDS:** All Bids shall be irrevocable unless the Bid is withdrawn as provided herein. All Bids may be withdrawn only by written communication delivered to the Purchasing Department prior to the solicitation closing date and time. The Bidder must present certification to assure that they are indeed an authorized representative of the Bidder's firm at the time such communication to withdraw the Bid is presented. A District representative shall verify this information prior to return of the Bid and Bid Security.

However, within twenty-four (24) hours after Bids are opened, any Bidder files a duly signed written notice with the District and successfully demonstrates that there was a material and



substantial mistake in the preparation of its Bid, that Bidder may withdraw its Bid, and the Bid Security will be returned. Bidder shall be disqualified from further bidding on the WORK to be provided under the Bid Documents.

30. **CONFLICT OF INTEREST:** All Bidders must disclose with their Bid the name of each of its employees, agents, or relatives who are employees of the DISTRICT. The Bidder represents and warrants to the District the following:

- No officer, employee, or agent of the District has any interest, either directly or indirectly, in the business of the Bidder to be conducted hereunder.
- Bidder has not employed or retained any company or person, other than a bona fide employee working solely for the Bidder, to solicit or secure this contract, and that it has not paid, or agreed to pay any person, company, corporation, individual, or firm, other than bona fide Personnel working solely for the Bidder any fee, commission, percentage, gift or other consideration, contingent upon, or resulting from the award or making of this contract.
- Bidder acknowledges that it has not agreed as an expressed or implied condition for obtaining this contract, to employ or retain the services of any person, company, individual or firm in connection with carrying out this contract.
- Bidder represents that it presently has no interest, either direct or indirect, while performing the services required by this contract, which would conflict in any manner with Florida Statutes.
- Bidder represents that no person having any such interest shall be employed during the term of this contract, including any officer, employee or agent of the District.
- Bidder represents and warrants that it has no current contracts with any entity that would create any conflict of interest in the Bidder's ability to perform the services required by this contract. Further, the Contractor represents and warrants that throughout the term of this contract, it will not undertake any work that would create such a conflict in interest.

It is understood and agreed by the Bidder that, upon the breach or violation of this Section, the District shall have the right to terminate the contract without liability and at its sole discretion, and to deduct from the contract price, or to otherwise recover, the full amount of such fee, commission, percentage, gift or consideration paid by the Bidder.

The Bidder shall promptly notify the District in writing by certified mail or electronic mail of all potential conflicts of interest for any prospective business association, interest or other circumstance that may influence or appear to influence the Bidder's judgment or quality of services being provided hereunder. Such written notification shall identify the prospective business association, interest or circumstance, the nature of work that the Bidder may undertake and request an opinion of the District as to whether the association, interest or circumstance would, in the opinion of the District, constitute a conflict of interest if entered into by the Bidder. If, in the opinion of the District, the prospective business association, interest or circumstance would not constitute a conflict of interest by the Bidder, the District shall so state in the notification and the Bidder shall, at its option, enter into such association, interest or circumstance and it shall be deemed not in conflict of interest with respect to services provided to the District by the Bidder under the terms of this Contract.

31. **NON-COLLUSION:** By submitting a bid, the Bidder certifies that it has not divulged discussed or compared its Bid with other Bidders

and has not colluded with any other Bidder or parties to a Bid whatsoever. No employee of the School Board has or shall benefit financially or materially from such solicitation or subsequent contract. Any contract issued as a result of this solicitation may be terminated at such time as it is determined that gratuities of any kind were either offered or received by any of the aforementioned persons. (Note: Premiums, rebates or gratuities are not permitted with, prior to, or after any delivery of material.) Any such violation shall result in the cancellation and/or return of materials (as applicable) as being non-conforming.

32. **PUBLIC ENTITY CRIMES:** The Bidder certifies that neither it nor its principals is presently debarred, suspended, proposed for debarment, declared ineligible or voluntarily excluded from participation in this transaction by the State of Florida or Federal Government. Further, Bidder certifies that it has divulged, in its bid response information regarding any of these actions or proposed actions with other governmental agencies

Pursuant to Section F.S. 287.133, FS as amended: a person or affiliate who has been placed on the convicted vendor list following a conviction for a public entity crime may not submit a Bid on a Contract to provide any goods or services to a public entity, may not submit a Bid on a Contract with a public entity for the construction or repair of a public building or public work, may not submit Bids on leases of real property to a public entity, may not be awarded or perform work as a Vendor, supplier, subvendor, or consultant under a Contract with any public entity, and may not transact business with any public entity in excess of the threshold amount provided in F.S. 287.017 for CATEGORY TWO or higher for a period of 36 months from the date of being placed on the convicted vendor list.

The awarded Bidder or any subcontractor shall not employ any persons with multiple felonies and / or crimes against children. The awarded Bidder must provide documented proof of efforts to comply with this requirement. The Owner may declare any non-compliance or lack of diligent effort by the awarded Bidder to comply as a breach of contract and immediately terminate the services of the awarded Bidder.

Any employees involved in any F.S. Chapter 435, Florida Statutes offenses are precluded from continuing to work on a project and must be replaced. Failure to comply may result in the immediate termination of the awarded Bidder's contract at the sole discretion of the District. Lack of knowledge by the Bidder shall in no way be a cause for relief from responsibility.

33. **PUBLIC RECORDS:** Any material submitted in response to this Invitation to Bid shall become a public document pursuant to Section 119.07, FS. This includes material that the responding BIDDER might consider to be confidential or a trade secret. Any claim of confidentiality is waived upon submission, effective after opening of Bids pursuant to Section 119.07, FS.

If the Contractor has questions regarding the application of chapter 119, Florida statutes, to the Contractor's duty to provide public records relating to this contract, contact the custodian of public records at 772. 219.1200, ext. 30201, 1939 SE Federal



Highway, Stuart, Florida 34994 or [click here.](#)

In compliance with F.S. 119.0701 the Contractor shall:

- Keep and maintain public records required by the public agency to perform the service.
- Upon request from the public agency's custodian of public records, provide the public agency with a copy of the requested records or allow the records to be inspected or copied within a reasonable time at a cost that does not exceed the cost provided in this chapter or as otherwise provided by law.
- Ensure that public records that are exempt or confidential and exempt from public records disclosure requirements are not disclosed except as authorized by law for the duration of the contract term and following completion of the contract if the contractor does not transfer the records to the public agency.
- Upon completion of the contract, transfer, at no cost, to the public agency all public records in possession of the contractor or keep and maintain public records required by the public agency to perform the service. If the contractor transfers all public records to the public agency upon completion of the contract, the contractor shall destroy any duplicate public records that are exempt or confidential and exempt from public records disclosure requirements. If the contractor keeps and maintains public records upon completion of the contract, the contractor shall meet all applicable requirements for retaining public records. All records stored electronically must be provided to the public agency, upon request from the public agency's custodian of public records, in a format that is compatible with the information technology systems of the public agency.
- A request to inspect or copy public records relating to a public agency's contract for services must be made directly to the public agency. If the public agency does not possess the requested records, the public agency shall immediately notify the contractor of the request, and the contractor must provide the records to the public agency or allow the records to be inspected or copied within a reasonable time.
- If a contractor does not comply with the public agency's request for records, the public agency shall enforce the contract provisions in accordance with the contract.
- A contractor who fails to provide the public records to the public agency within a reasonable time may be subject to penalties under F.S. 119.10.
- If a civil action is filed against a contractor to compel production of public records relating to a public agency's contract for services, the court shall assess and award against the contractor the reasonable costs of enforcement, including reasonable attorney fees, if:
 1. The court determines that the contractor unlawfully refused to comply with the public records request within a reasonable time; and
 2. At least eight (8) business days before filing the action, the plaintiff provided written notice of the public records request, including a statement that the contractor has not complied with the request, to the public agency and to the contractor.

- A notice complies with subparagraph 2 above, if it is sent to the public agency's custodian of public records and to the contractor at the contractor's address listed on its contract with the public agency or to the contractor's registered agent. Such notices must be sent by common carrier delivery service or by registered, Global Express Guaranteed, or certified mail, with postage or shipping paid by the sender and with evidence of delivery, which may be in an electronic format.
- A Contractor who complies with a public records request within eight (8) business days after the notice is sent is not liable for the reasonable costs of enforcement.

- 34 **LICENSES:** Bidders, both corporate and individual, must be fully licensed and certified for the type of work to be performed in the State of Florida at the time of receipt. The submittal of any bid from a Contractor that is not fully licensed and/or certified shall be rejected.
- 35 **PERMITS:** The Bidder(s) shall be responsible for obtaining any necessary permits and shall comply with laws, rules, and regulations whether state or federal and with all local codes and ordinances without additional cost to the District.
- 36 **SUNBIZ:** Bidders, both corporate and individual, must provide proof that their firm is registered with the Division of Corporations for the State of Florida.
- 37 **BUSINESS TAX RECEIPT:** Bidder shall comply with Business Tax Receipt requirements for their business location, if applicable. A copy of the business tax receipt or proof of exemption must be included with the submittal package, if applicable.
- 38 **BIDDER MAILING ADDRESS:** It is the responsibility of every Bidder to register and maintain their current registration information. Bidders that have received the ITB from DemandStar.com must maintain their information on the DemandStar database. Bidders that have received the ITB documents from Vendor Registry must maintain their information on their database. The information used by the Purchasing Department is maintained at <http://www.demandstar.com>. DemandStar shall be used to make notice of ITBs and other information to Bidders.
- 39 **ANTI-DISCRIMINATION:** The Bidder certifies that they are in compliance with the non-discrimination clause contained in Section 202, Executive Order 11246, as amended by Executive Order 11375 relative to equal employment opportunity for all persons without regard to race, color, religion, sex or national origin. The provisions of the ADA Act of 1990 pertaining to employment shall also be applicable.

The Bidder shall not discriminate on the basis of race, gender, gender identity or expression, religion, national origin, ethnicity, sexual orientation, age or disability in the solicitation, selection, hiring, or treatment of sub-contractors, vendors, suppliers, or commercial customers. Bidder shall provide equal opportunity for sub-contractors to participate in all of its public sector and private sector sub-contracting opportunities. Bidder understands and agrees that violation of this clause is a material breach of the contract and may result in contract termination, debarment, or other sanctions.
- 40 **MINORITY BUSINESS PARTICIPATION:** The District strongly encourages the use of Minority/Woman owned business enterprises for participation as associates, joint ventures, prime Contractors, and subcontractors in contracting opportunities.
- 41 **JOINT BIDS:** In the event multiple proposers submit a joint Bid in response to the BID, a single proposer shall be identified as the



Prime Vendor. If offering a joint Bid, Prime Vendor must include the name and address of all parties of the joint Bid. Prime Vendor shall provide all bonding and insurance requirements, execute any Contract, complete the **REQUIRED RESPONSE FORM** shown herein, and have overall and complete accountability to resolve any dispute arising within this contract. Only a single contract with one proposer shall be acceptable. Prime Vendor responsibilities shall include, but not be limited to, performing of overall contract administration, preside over other proposers participating or present at District meetings, oversee preparation of reports and presentations, and file any notice of protest and final protest as described herein. The Prime Vendor shall also prepare and present a consolidated invoice(s) for services performed. The District shall issue only one check for each consolidated invoice to the Prime Vendor for services performed. The Prime Vendor shall remain responsible for performing services associated with response to this BID.

42. **LOBBYING:** Contractors are hereby advised that they are not to lobby with any district personnel or board members related to or involved with this solicitation. Lobbying is defined as any action taken by an individual, firm, association, joint venture, partnership, syndicate, corporation, and all other groups who seek to influence the governmental decision of a board member or district personnel after advertisement and prior to the posted recommendation on the award of the Contract.

Bidders are hereby advised they are not to lobby with any District personnel or board members related to or involved with this bid until recommendation for award. All oral or written inquiries must be directed through the Purchasing Department.

Any Bidder or any individuals that lobby on behalf of Bidder during the time specified shall result in rejection / disqualification of said bid.

43. **BYRD ANTI-LOBBYING AMENDMENT:** Contractors that apply or propose for an award of \$100,000 or more must file the required certifications. Each tier certifies to the tier above that it will not and has not used Federal appropriated funds to pay any person or organization for influencing or attempting to influence an officer or employee of any agency, a member of Congress, officer or employee of Congress, or an employee of a member of Congress with or an employee of a member of Congress in connection with obtaining any Federal contract, grant or any other award covered by 31 U.S.C. 1352. Each tier must also disclose any lobbying with non-Federal funds that takes place in connection with obtaining any Federal award. Such disclosures are forwarded from tier to tier, up to the non-Federal award.

44. **KICKBACKS:** Any Contractor giving or offering to any employee and/or official of the School Board, either directly or indirectly, any rebate, percentage of contract, money or other things of value as an inducement or intended inducement, in the procurement of this or any other solicitation, shall be deemed in violation of this agreement, in addition to being in violation of any other municipal, county, state and federal laws and/or ordinances.

45. **CONE OF SILENCE:** A cone of silence is hereby established for all competitive selection processes for the provision of goods and services. The cone of silence is designed to protect the integrity of the procurement process by shielding it from undue influences prior to the recommendation of contract award. This cone of silence shall be imposed on these procurements after advertisement of same.

The cone of silence prohibits any communication regarding a competitive solicitation process. The cone of silence commences after the advertisement of the competitive solicitations. Competitive procurements are advertised on the purchasing department's web page or in a newspaper of general circulation.

The cone of silence terminates at the time the School Board acts

on a written recommendation from the purchasing department or planning and construction department regarding contract award; provided, however, that communications are permitted when the School Board receives public comment at the meeting when the recommendation is presented.

Section 119.071(1)(b)2., F.S., provides an exemption for "sealed bids, proposals, or replies received by an agency pursuant to a competitive solicitation" until such time as the agency provides notice of an intended decision or until 30 days after opening "the bids, proposals, or final replies," whichever is earlier.

The purchasing department and planning and construction department shall ensure that all solicitations include provisions describing the requirements and prohibitions of the cone of silence, including how a potential vendor, service provider, Bidder, lobbyist, or consultant may communicate with District personnel.

Any person, whether employed by the District or not, who knowingly violates a provision of this policy shall be prohibited from serving on a District competitive selection committee.

Violation of this policy by a particular Bidder, proposer, respondent, and/or representative may, at the discretion of the District, result in rejection of said Bidder, proposer, respondent, and/or representative's bid, proposal, or offer and may render any contract award to said Bidder, proposer, or respondent voidable.

In addition to any other penalty provided by law, violation of this policy by a District employee shall subject said employee to disciplinary action up to and including dismissal from service.

46. **ASSIGNMENT:** The successful Bidder shall not assign, transfer, convey, sublet, or otherwise dispose of the contract, or of any or all of its rights, title, or interest therein, or its power to execute such contract to any person, firm, or corporation without prior written consent of the District.

47. **SUBCONTRACTING:** If an awarded Bidder intends to subcontract any portion of the Contract for any reason, the name and address of the subcontracting firm must be submitted along with the Bidder's bid or prior to work for approval. The Purchasing Department reserves the right to reject a subcontractor who previously failed in the proper performance of a contract or failed to deliver on-time contracts of a similar nature, or who, the DISTRICT has determined in its sole discretion, is not in the position to perform the contract due to the subcontractor's size, experience, or resources.

In addition, the awarded Bidder's subcontractors shall comply with all requirements of Fla. Stat. 1012.32 and 1012.465 by completing the fingerprint screening required of the awarded Bidder and all of its employees /subcontractors who provide services under this contract.

If requested by the District, Contractor shall provide an experience statement with pertinent information regarding similar projects and other evidence of qualification for each Subcontractor, Supplier, person or organization. If the District or EOR after due investigation has reasonable objection to any proposed Subcontractor, Supplier, other person or organization, either may, before the Notice of Tentative Award is given, request the apparent Successful Bidder to submit an acceptable substitute without an increase in Bid price.

If the apparent Successful Bidder declines to make any such substitution, the District may award the contract to the next lowest Bidder that proposes to use acceptable Subcontractors, Suppliers and other persons and organizations. The declining to make requested substitutions **shall constitute grounds** for sacrificing the Bid Security of any Bidder. Any Subcontractor, Supplier, other person or organization listed and to whom the District or



EOR does not make written objection prior to the giving of the Notice of Tentative Award will be deemed acceptable to the District subject to revocation of such acceptance after the Effective Date of the Contract. Subcontractors shall not be changed without the approval of the District. No acceptance by the District of any such Subcontractor, Supplier or other person or organization shall constitute a waiver of any right of the District or EOR to reject defective Work or materials not conforming to these specifications.

In contracts where the Contract Price is on the basis of Cost-of-the-Work Plus a Fee, the apparent Successful Bidder, prior to the Notice of Tentative Award, shall identify in writing to the District those portions of the Work that such Bidder proposes to subcontract and after the Notice of Tentative Award the Successful Bidder may only subcontract other portions of the Work with the District's written consent.

No BIDDER shall be required to employ any Subcontractor, other person or organization against which Bidder has reasonable objection.

48. **REPRESENTATIVE:** At all times during the term of the contract, the successful Contractor shall act as an independent Contractor and at no time shall be considered an agent or partner of the District.
49. **BONDING GUARANTY/EVIDENCE:** If applicable, the Bid submittal **must** be accompanied by a notarized letter from your firm's Surety guaranteeing that if your firm is awarded a contract, the Surety will issue a letter of credit that attests to the bonding capacity (the maximum amount of surety credit a surety company) will provide to a contractor, contingent upon a top-notch organization, strong financial presentation, and experience. The Surety shall also guarantee your firm by issuing Performance and Payment bonds as required by the District. Failure to submit the Surety Guaranty letter with your Bid shall cause your bid to be rejected as non-responsive. The District shall be the sole judge in determining Bonding Capacity.
50. **PROPOSAL AS PUBLIC DOMAIN:** All documents and other materials made or received in conjunction with this project will be subject to public disclosure requirements of chapter 119, Florida Statutes. This includes material that the responding Proposer might consider to be confidential or a trade secret. The proposal will become part of the public domain upon opening. **Respondents shall not submit pages marked "proprietary" or otherwise "restricted".**



SECTION III
GENERAL TERMS AND CONDITIONS

These general terms and conditions apply to all offers made to the Martin County School District by all prospective Bidders, including but not limited to, Request for Quotes, Invitations to Bid, and Request for Proposals. As such the words "RFP", "Bid", and "Proposal" are used interchangeably in reference to all offers submitted by prospective Bidders.

Where there appears to be variances or conflicts between the General Terms and Conditions, Special Conditions and/or Detailed Specifications outlined in this ITB, Section III, General Terms and Conditions, Item #2, Order of Precedence shall prevail.

1. **TERM CONTRACT:** At all times during the term of the contract, the successful Contractor(s) shall act as an independent Contractor and at no time shall be considered an agent or partner of the District.
 - 1.1 **Contract Period:** This contract shall be firm for one (1) year, subsequent to approval by the proper District authorities. The contract may be renewed for two (2) additional (1) one year periods provided both the successful Bidders and the District agree and all terms and conditions remain the same. Any contract or amendment resulting from this solicitation shall be subject to fund availability and mutual written agreement between the District and the successful Bidder.
 - 1.2 **Option to Renew:** The performance period of any contract resulting from this solicitation may be renewed upon mutual agreement between the contractor and the District with no change in terms or conditions. Any extension of performance period under this provision shall be in one-year increments. The contract may be renewed for two (2) additional one-year periods, provided both parties are in agreement. Total contract length, including individual one-year extensions, shall not exceed three (3) years.
 - 1.3 **Price Increase:** Consideration of price increases at each renewal period will be given provided such escalations are justified, reasonable and acceptable to the District, and are based on claims and annual renewal trends. Any price increases must be documented and approved by the District only when a written request is received a minimum of one hundred and eighty (180) days prior to the renewal date. It is also expected that de-escalation of prices will be extended to the District if the market so reflects. The District reserves the right to not renew any contract regardless of price considerations.
 - 1.4 **Contract Extension:** The District reserves the right to automatically extend any Contract for up to ninety (90) calendar days beyond the stated Contract term, under the same terms and conditions of said Contract. Additional extensions over the first ninety (90) day extension may not exceed 6 months for the convenience of either party by mutual agreement to such extensions. The District shall notify the Successful Bidder in writing of such extensions.
 - 1.5 **Contract Amendment:** MCSB may require additional products or services of a similar nature, but not specifically identified in the contract. The Contractor agrees to provide such items, and shall provide the District prices on such additional items based upon a formula or method which is the same or similar to that used in establishing the prices in this bid. If the price(s) offered are not acceptable to the District, and the situation cannot be resolved to the satisfaction of the District, the District reserves the right to procure those items/services from other vendors or to cancel the contract. Furthermore, the District reserves the right to delete or revise items and services under this proposal at any time during the contract period when and where deemed necessary. Deletions may be made at the sole discretion of the District at any time during the contract period. Items revised must be mutually agreed upon in writing by the Contractor.
2. **ADVERTISING:** In submitting a Bid, Bidder agrees not to use the results there from as a part of any commercial advertising.
3. **ORDER OF PRECEDENCE:** In resolving conflicts resulting from errors or discrepancies in any of the ITB or Contract Documents, the order of precedence (lower number item controls) shall be as follows:
 - Amendment
 - Change Order
 - Contract/Agreement or Purchase Order
 - Technical Specifications/Attachments
 - Forms, Schedule of Prices
 - Scope of Work
 - Special Conditions
 - Insurance Requirements
 - General Terms and Conditions
 - Instructions to Bidders
 - Invitation to Bid
4. **BID SECURITY:** When required by the Bid documents, (as specified in Section V Special Conditions) each Bid must be accompanied by a Bid security made payable to the Martin County School District in an amount of five percent (5%) of the Bidder's maximum Bid price and in the form of a certified check or cashier's check drawn upon any State or National Bank of Florida or a Bid Bond issued by a Surety that must have a "Best" rating of "A", and be authorized to do business in Florida.

Said check or Bid Bond shall be made payable to the Martin County School District and shall be given as a guarantee that Bidder, upon receipt of Notice of Tentative Award of the purchase order or contract, shall enter into the Contract or accept the purchaser order with the District, and furnish the necessary documents including, but not limited to: insurance certificates, other required Bonds, each of the said Bonds to be in the amount stated on the Invitation to Bid.

The Attorney-in-Fact who signs the bond must file with the bond a current certificate of proof of appointment as Attorney-In-Fact.

The Bid Security of the Successful Bidder shall be retained until such Bidder has been awarded a binding Contract or Purchase Order or Contract security whereupon the Bid security shall be returned. If the apparent Successful Bidder fails to execute and deliver the Purchase Order or Contract and furnish the required contract security within ten (10) calendar days after the Notice of Award, which is issued prior to the District's award of Purchase Order or Contract, the District may annul the Notice of Award, and the bid security of that Bidder shall be forfeited and retained by the District. The District may then recommend to the Board to accept the Bid of the next lowest responding Bidder, or re-



advertise for bids. If the Bid of the next lowest Bidder is accepted, this acceptance shall bind such Bidder as though it was the original Successful Bidder.

There shall be no binding contract until such time as the Board or designee executes the Contract or issues the Purchase Order as the final award of the contract. The Bid Security of other Bidders whom District believes to have a reasonable chance of receiving the award may be retained by the District until the earlier of the seventh day after the effective date of the Purchase Order or Contract or the ninety-first day after the Bid opening, whereupon Bid security furnished by such Bidders shall be returned. Bid security with Bids which are not competitive or responsive shall be returned upon award of the Bid.

5. **EXAMINATION OF BID DOCUMENTS & SITE:** Bidder must satisfy itself by personal and thorough examination of the location of the proposed Work, Bid Documents, requirements of the Work and the accuracy of the estimate of the quantities of the Work to be done; and Bidder shall not at any time after the submission of a Bid dispute or complain of such estimate nor the nature or amount of Work to be done.

By submission of its Bid, Bidder affirms that it has, at its own expense, made or obtained any additional examinations, investigations, explorations, tests, and studies and obtained any additional information and data which pertain to the physical conditions (surface, subsurface, and Underground Utilities) at or contiguous to the site or otherwise, prior to bidding which may affect cost, progress, or performance of the Work and which Bidder deems necessary to determine its Bid for performing the Work in accordance with the time, price, and other terms and conditions of the Bid Documents and/or Bidder has satisfied itself with respect to such conditions and it shall make no claims against the District or the EOR if on carrying out the Work it finds that the actual conditions do not conform to those indicated.

On request, the District will provide Bidder access to the site to conduct such investigations and tests, as Bidder deems necessary for submission of its Bid. Bidder shall schedule such access in advance with the District.

Upon completion of such additional field investigations and tests, Bidder shall completely restore disturbed areas.

6. **ADJUSTMENTS/CHANGES/DEVIATIONS:** No adjustments, changes, or deviations shall be accepted on any item unless conditions or Specifications of a Bid expressly so provide. All adjustments, changes or deviations shall require prior written approval and shall be binding **ONLY** if issued through the District's Purchasing Office.
7. **BID EXEMPT:** Purchases shall not include any items or services available at lower prices on other public entity or State of Florida Contract. The District reserves the right to Bid separately any item or service if deemed to be in the best interest of the District.
8. **PROMOTIONAL PRICING:** In addition, Bidder shall offer to the District, during the Contract period, any item(s) offered on a "promotional" basis from the manufacturer. It shall be the successful Bidder's responsibility to monitor said item(s) and report any that are or shall be offered at lower price.
9. **CONTRACT SECURITY/INSURANCE:** When required by the specification herein, the successful Bidder shall furnish, a Performance Bond, Payment bond, and/or Warranty bond, and insurance certificates as stated on the cover page of this solicitation, on the District's forms, within ten (10) calendar

days after notification of award. Failure to furnish the required bonds within the time specified may be cause for rejection of the bid and any bid deposit may be retained by the District as liquidated damages and not as a penalty. Said sum shall be a fair estimate of the amount of damages the District would sustain due to Bidder's failure to furnish said bonds.

10. **PRICES:** Bid prices shall be fixed and firm to the extent required under Special Conditions. In the absence of a reference in the Special Conditions, bid prices shall be fixed and firm for a period of ninety (90) calendar days. Give both unit price and extend total. Prices must be stated in units of quantity specified in the bid specifications. In case of a discrepancy in computing the amount of the bid, the UNIT PRICE quoted shall govern. All prices FOB destination, freight prepaid (unless otherwise stated in special conditions). Each item must be bid separately and no attempt is to be made to tie any item or items in with any other item or items. Payment shall be made only after receipt and acceptance of materials/services. Cash discounts may be offered for prompt payment; however, such discounts shall not be considered in determining the lowest net cost for bid evaluation.

All payments shall be governed by the *Local Government Prompt Payment Act*, F.S. Chapter 218.

11. **DELIVERY:** All items shall be delivered F.O.B. destination to a specific District address. All delivery costs and charges must be included in the bid price. The District reserves the right to cancel orders or any part thereof, without obligation if delivery is not made at the time specified in the bid.

Unless actual date of delivery is specified, show number of days required to make delivery after receipt of purchase order in space provided. Delivery time may become a basis for making an award

NOTE TO VENDORS DELIVERING TO MARTIN COUNTY SCHOOLS WAREHOUSE: Normal receiving hours are Monday through Friday (excluding holidays) 7:00 A.M. to 2:30 P.M. Summer receiving hours, typically mid-June to early August, are 6:30 AM to 3:30 PM, Monday through Thursday. This warehouse is located at 2845 SE Dixie Highway, Building #7, Stuart, Florida 34997.

12. **MISTAKES:** Bidders are expected to examine the Specifications, Plans, Delivery Schedule, Bid prices, Extensions and all Instructions pertaining to supplies and services. **FAILURE TO DO SO SHALL BE AT THE BIDDER'S RISK.** In the event of extension error(s), the unit price shall prevail and the Bidder's total offer shall be corrected accordingly. Erasures or corrections on Bids must be initialed in ink by the Bidder.

Discrepancies in the multiplication of units of Work and unit prices will be resolved in favor of the unit price. Discrepancies between the indicated sum of any column of figures and the correct sum thereof will be resolved in favor of the correct sum.

13. **INVOICING AND PAYMENT:** Payment for any and all invoice(s) that may arise as a result of a Contract or Purchase Order issued pursuant to this Bid Specification shall minimally meet the following conditions to be considered as a valid payment request. **If progress payments are applied for, all invoicing and payments shall be as stipulated under the Special Conditions section titled "Progress Payments".**

Timely submission of a property certified invoice(s) in strict accordance with the price(s) and delivery elements as stipulated in the Contract document should be submitted to:



Martin County School District
 Attn: Accounts Payable Department
 1939 SE Federal Highway
 Stuart, FL., 34994
invoices@martinschools.org

All invoices shall be based upon and submitted with an approved Schedule of Values. Said Schedule of Values shall also contain a percentage breakdown of the supplies and services completed for which payment is requested in comparison to the total contract.

All invoices submitted shall consist of an original and one (1) copy;

- clearly referenced the subject Contract or Purchase Order number;
- provide a sufficient salient description to identify the goods or services for which payment is requested;
- contain date of delivery;
- original or legible copy of a signed delivery receipt including both manual signature and printed name of a designated District employee or authorized agent; be clearly marked as "partial", "complete" or "final" invoice. The District shall accept partial deliveries.

The invoice shall contain the Bidder's Federal Employer Identification number.

The District's terms of payment, unless otherwise stated in the Contract or Purchase Order documents, are "Net 30 Days" after acceptance of goods or services and receipt of an acceptable invoice as described herein. Any other items of payment must have been previously approved by the District and appear on the Contract or Purchase Order document to be binding on the District.

Should the District return an invoice for correction, the Vendor shall resubmit a corrected invoice to the District for processing.

Payment will be made after the goods/services from the awarded Proposer have been received/completed; inspected and found to comply with negotiated contract, free of damage or defect; and a properly billed invoice is received and processed in the Accounting Services Department.

14. **ESTIMATED QUANTITIES:** The estimate of the various quantities of work or goods applicable to unit price items as shown on the Bid Form is approximate and is intended solely to provide the basis of comparison upon which the Award of Contract is made. Final payment shall be made on the basis of the actual quantities received.

The District reserves the right to reduce the quantities of Work to be done and to completely eliminate any items of the work listed in the Bid Form in order that the work can be completed within the amount of available funds.

15. **SUBSTITUTE or "OR EQUAL ITEMS":** The Contract, if awarded, will be on the basis of material and equipment described in the Drawings or specified in the Specifications without consideration of possible substitute or "or-equal" items. Whenever it is indicated in the Drawings or specified in the Specifications that a substitute or "or-equal" item of material or equipment may be furnished or used by Successful Bidder if acceptable to District, application for such acceptance must be made fifteen (15) calendar days prior to the Bid opening date, or such application will not be considered by District. The procedure for submittal of any such application, including those applications made after award of the Construction Contract by Successful Bidder

16. **UNBALANCED BIDS:** Bids that are judged to be mathematically or materially unbalanced shall be cause for the bid to be rejected as non-responsive.
17. **ESTIMATED DOLLAR VALUE:** No guarantee of the dollar amount of this Bid is implied or given.
18. **INCORRECT PRICING/INVOICES:** Any pricing on invoices that are incorrect and were not included on the original Purchase Order, must be brought to the attention of the Purchasing Agent and corrected prior to the shipment(s) of goods or initiation of services. Additional costs that were not brought to the District's attention and did not receive written approval via a Change Order issued by the Purchasing Agent shall not be honored.
19. **DISTRICT PURCHASING CARD:** The School District has authorized the use of a Purchasing Card to expedite small dollar purchases for materials, supplies, and other items needed for daily operations. Awarded Bidders may be presented these credit cards by authorized School District personnel for the above mentioned purchases. Bidder (with the exception of travel). Purchase orders are strongly discouraged for purchasing materials, and supplies under \$1,000.
20. **CHANGE ORDERS:** Any addition(s) to the Statement of Work or to a Purchase Order as a result of the ITB award that adds additional costs must be brought to the School Districts attention and approved by the Purchasing Department prior to commencement of additional work, shipment of goods or the addition of unauthorized freight charges. Once approved, a Change Order shall be issued to include the additional costs and work may commence and/or shipment of goods can begin. Additional costs that were not brought to the district's attention and did not result in a Change Order approved by the Purchasing Department shall not be honored.
21. **DISPUTES:** In case of any doubt or difference of opinion as to the services to be furnished hereunder, the decision of the District shall be final and binding on both parties.
22. **BID PROTEST:** Failure to file a protest within the time prescribed in Section 120.57(3), Florida Statutes, shall constitute a waiver of proceedings under Chapter 120, Florida Statutes.
- 22.1 Any person who is adversely affected by the agency decision or intended decision shall file with the agency a notice of protest in writing within 72 hours after the posting of the notice of decision or intended decision.
- 22.2 With respect to a protest of the terms, conditions, and specifications contained in a solicitation, including any provisions governing the methods for ranking proposals, or replies, awarding contracts, reserving rights of further negotiation, or modifying or amending any contract, the notice of protest shall be filed in writing within 72 hours after the advertisement of the solicitation.
- 22.3 The formal written protest shall be filed within 10 days after the date the notice of protest is filed. Failure to file a notice of protest or failure to file a formal written protest shall constitute a waiver of proceedings under this chapter. The formal written protest shall state with particularity the facts and law upon which the protest is based. Saturdays, Sundays, and state holidays shall be excluded in the computation of the 72-hour time periods provided by this paragraph.



- 22.4 In order for the District to consider the protest, the protesting party shall deliver with the formal written protest to the District a "protest bond" in the amount as follows:
- 22.4.1 Twenty-five thousand dollars (\$25,000) or 2 percent (2%) of the lowest accepted proposal, whichever is greater, for projects valued over \$500,000; and
- 22.4.2 Five percent (5%) of the lowest accepted proposal for all other projects, conditioned upon payment of all costs and fees which may be adjudged against the protestor in the administrative hearing.
- 22.4.3 If at the hearing the agency prevails, it shall recover all costs and attorney's fees from the protestor; if the protestor prevails, the protestor shall recover from the agency all costs and attorney's fees.
- 22.4.4 If the protest (with respect to 21.2 above) the protest bond shall be the same as 21.4.1 and 21.4.2, except that the protest bond amount shall be calculated against the budgeted amount of the project.
23. **DEBARMENT:** The Board shall have the authority to debar a person / corporation for cause for consideration or award of future contracts. The debarment shall be for a period commensurate with the seriousness of the causes, generally not to exceed three (3) years. When the offense is willful or blatant, a longer term of debarment may be imposed, up to an indefinite period.
24. **FEDERAL DEBARMENT CERTIFICATION:** Certification regarding debarment, suspension, ineligibility and voluntary exclusion as required by Executive Order 12549, Debarment and Suspension, and implemented at 34 CFR, Part 85, as defined at 34 CFR Part 85, Sections 85.105 and 85.110-(ED80-0013).
- a. The prospective lower tier participant certifies, by submission and signature of this submittal, that neither it nor its principals is presently debarred, suspended, proposed for debarment, declared ineligible, or voluntarily excluded from participation in this transaction by any federal department or agency.
- b. Where the prospective lower tier participant is unable to certify to any of the statements in this certification, such prospective participant shall attach an explanation to this solicitation.
25. **DELETION/OVERSIGHT/MISSTATEMENT:** Any deletion, oversight or misstatement of the Specifications shall not release the Bidder from the responsibility of completing the project within the agreed upon time frame.
26. **SCRUTINIZED COMPANIES:** Pursuant to Sections 287.135, 215.4725, and 215.473, of the Florida Statutes which prohibits agencies from contracting with any company, principals, or owners on the Scrutinized Companies with Activities in Sudan List, participation in the Boycott of Israel, the Scrutinized Companies with Activities in the Iran Petroleum Energy List, and is not engaged in business operations in Cuba or Syria are prohibited from contracting for goods or services in any amount at the time of submitting to this solicitation through the term of this contract, including renewals or extensions.
- Acceptance of an offer certifies Contractor attests that firm is not on any list, engaged in any business operations, or participates in activities as specified in this section. If firm is found negligent, contract shall be terminated; and
- submission of a false certification may subject firm to civil penalties, attorney's fees, and/or costs
27. **DEMONSTRATIONS/SAMPLES/MOCKUPS:** The District may request a full demonstration of any product or service before the award of a contract. All demonstrations will be done at the expense of the Bidder.
- When requested, samples are to be furnished free of charge to the District. If a sample is requested it must be delivered within seven (7) days of the request unless otherwise stated in the bid documents. Each sample must be marked with the following:
- The Bidder's name, the bid item and the manufacturer's number.
 - Samples shall not be returned unless the Bidder requests it when samples are delivered.
 - Samples must be a complete pack, box, bag, etc. of the required item(s), packaged as specified in the bid document.
 - Failure to provide samples packaged as required by the bid specifications shall result in the item(s) and/ or the bid being rejected as nonconforming.
 - Items may be tested for compliance with specifications under the direction of the Florida Department of Agriculture and Consumer Services, or an independent testing laboratory. Bidders shall assume full responsibility for payment for any and all charges for testing and analysis of any materials offered or delivered that **do not conform** to the minimum required specifications. Bidder's disposition of all items delivered in this category must be at no expense to the District.
- The DISTRICT may request a full demonstration of any product or service before the award of a contract. All demonstrations shall be done at the expense of the BIDDER.
- Mockups must be approved prior to work beginning. The mockup shall be the basis for the quality of work and the work's acceptance.
28. **COPYRIGHTS OR PATENT RIGHTS:** The Bidder warrants that there has been no violation of copyrights or patent rights in the manufacturing, producing or selling the goods shipped or ordered as a result of this ITB. The seller agrees to hold the District harmless from all liability, loss or expense occasioned by any such violation.
29. **DEFAULT:** In case of default by the Bidder, the Board may procure the articles or services from other sources and hold the Bidder responsible for any excess costs incurred released.
30. **EMPLOYEES:** Employees of the awarded Bidder shall at all times be under its sole direction and not an employee or agent of the District. The Awarded Bidder shall supply competent and physically capable employees. The District may require the Awarded Bidder to remove an employee it deems careless, incompetent, insubordinate or otherwise objectionable. Awarded Bidder shall be responsible to the District for the acts and omissions of all employees working under its directions.
31. **NON-DISCRIMINATION & EQUAL OPPORTUNITY EMPLOYMENT:** The Bidder certifies that they are in compliance with the non-discrimination clause contained in



- Section 202, Executive Order 11246, as amended by Executive Order 11375 relative to equal employment opportunity for all persons without regard to race, color, religion, sex or national origin. The provisions of the ADA Act of 1990 pertaining to employment shall also be applicable.
- 31.1 During the performance of the Contract, the awarded Bidder shall not discriminate against any employee or applicant for employment because of race, gender, gender identity or expression, religion, national origin, ethnicity, sexual orientation, marital status, political affiliation, familial status, age or disability in the solicitation, selection, hiring, or treatment of sub-contractors, vendors, suppliers, or commercial customers
- 31.2 The awarded Bidder will take affirmative action to ensure that employees are treated during employment, without regard to their race, religion, color, gender or national origin, or disability. Such actions must include, but not be limited to, employment, promotion; demotion or transfer; recruitment or recruitment advertising, layoff or termination; rates of pay or other forms of compensation; and selection for training, including apprenticeship.
- 31.3 The awarded Bidder shall agree to post in conspicuous places, available to employees and applicants for employment, notices to be provided by the contracting officer setting forth the provisions of this nondiscrimination clause.
- 31.4 The awarded Bidder further agrees that he/she will ensure that Subcontractors, if any, will be made aware of and will comply with this nondiscrimination clause. Bidder shall provide equal opportunity for sub-contractors to participate in all of its public sector and private sector sub-contracting opportunities.
- 31.5 Bidder understands and agrees that violation of this clause is a material breach of the contract and may result in contract termination, debarment, or other sanctions.
- 32 **TAXES:** The District is exempt from all Federal, State, and Local taxes. An exemption certificate will be provided.
- 33 **SALES TAX:** All materials and supplies necessary for completion of this contract are subject to Florida Sales and Use Tax in accordance with Florida Statutes and shall be included in the Contract Price stated by the Contractor.
- 34 **EXCLUSIVE RIGHTS-USE OF OTHER CONTRACTS:** The right to provide the commodities and services granted under this contract shall not be exclusive. The District reserves the right to utilize any other District contract, any State of Florida Contract, any contract awarded by any other city or county governmental agencies, any other school board, any other community college/state university system cooperative ITB agreement, or to directly negotiate/purchase per School Board policy and/or State Board Rule 6A-1.012(6) in lieu of any offer received or award made as a result of this ITB, if it is in the best interest to do so. The District also reserves the right to separately ITB any single order or to purchase any item on this ITB if it is in its best interest to do so.
- 35 **COOPERATIVE PURCHASING AGREEMENTS:** All Bidders submitting a response to this ITB agree that such response also constitutes a bid to all State Agencies and Political Subdivisions of the State of Florida under the same conditions, for the same prices and for the same effective period as this bid, ***should the awarded Bidder(s) deem it in the best interest of their business to do so.*** This agreement in no way restricts or interferes with any state agency or political subdivision of the State of Florida to re bid any or all items.
- 36 **RIGHTS TO BID DOCUMENTS:** All copies and contents of any bid, attachment, and explanation thereof submitted in response to this ITB (except copyright material), shall become the property of the School District of Martin County, Florida. The School District reserves the right to use, at its discretion, and in any manner it deems appropriate, any concept, idea, technique or suggestion contained therein. All copyright and industrial/commercial proprietary, confidential and/or privileged information such as financial records, must be clearly identified, as such confidentiality is protected until award of contract, in accordance with Chapter 119, F.S. Said material shall be returned to the Bidders prior to award of contract so as to preserve the proprietary and confidential nature of its contents.
- 37 **SEVERABILITY:** Indulgence by the District on any non-compliance by the Bidder does not constitute a waiver of any rights under this ITB. If any term or provision of this ITB or resulting Contract, or the application thereof to any person or circumstances shall, to any extent, be held invalid or unenforceable, the remainder of this ITB or Contract, or the application of such terms or provisions to persons or circumstances other than those as to which it is held invalid or unenforceable, shall not be affected, and every other term provision of this Bid/Contract shall be deemed valid and enforceable to the extent permitted by law.
- 38 **VENUE:** All contracts shall be governed by the laws of the State of Florida and venue shall be in Martin County, Florida. The venue of any legal action resulting from this Proposal shall be Martin County, Florida.
- 39 **EXPENSES:** Neither the DISTRICT nor its representatives shall be liable for any expenses incurred in connection with preparation of a response to this ITB. All expenses in the preparation of this ITB are the sole responsibility of the Bidder. All Submittals should be prepared to provide a straightforward and concise description of the respondents' qualifications and ability to meet the requirements of the ITB.
- 40 **SOVEREIGN IMMUNITY:** No Waiver of Sovereign Immunity: Nothing contained herein is intended to serve as a waiver of sovereign immunity by any agency or political subdivision to which sovereign immunity may be applicable or as a waiver of limits to liability or rights existing under Section 768.28, Florida Statutes.
- 41 **VERIFICATION OF EMPLOYMENT (E-VERIFY):** The District shall not intentionally award contracts to any contractor who knowingly employs unauthorized alien workers, constituting a violation of the employment provisions of the Immigration and Nationality Act ("INA"). The District shall consider the employment by the Contractor of unauthorized aliens a violation of 8 U.S.C. Section 1324a(e) [Section 274A(e) of the INA]. The Contractor agrees that such violation by the Contractor shall be grounds for the unilateral cancellation of this Contract by the District.
- a. Pursuant to Section 448.095, Florida Statutes, Contractor shall register with and use the U.S. Department of Homeland Security's E-Verify system to verify the work authorization status of all employees hired during the term of this Agreement and must, upon request, provide evidence of compliance with this provision.
- b. Subcontractors
- (i) Contractor shall also require all subcontractors performing work under this Agreement to use the E-Verify system for any employees they may hire during the term of this Agreement.
- (ii) Subcontractors shall provide Contractor with an affidavit stating the subcontractor does not employ, contract with, or subcontract with an



unauthorized alien, as stated in Section 448.095, Florida Statutes.

- (iii) Contractor shall provide a copy of such affidavit to the School Board upon receipt and shall maintain a copy for the duration of the Agreement.
- c. Failure to comply with this provision is a material breach of the Agreement, and School Board may choose to terminate the Agreement at its sole discretion. Contractor may be liable for all costs associated with School Board securing the same services, inclusive, but not limited to, higher costs for the same services and rebidding costs (if necessary).

42 DAVIS-BACON & LABOR STANDARDS

If applicable refer Section V-Special Conditions, Contractor agrees to comply with the requirements of the Secretary of Labor in accordance with the Davis-Bacon Act as amended, the provisions of Contract Work Hours and Safety Standards Act (40 U.S.C. 327 et seq.) and all other applicable Federal, state and local laws and regulations pertaining to labor standards insofar as those acts apply to the performance of this project. The Contractor agrees to comply with the Copeland Anti-Kick Back Act (18 U.S.C. 874 et seq.) and its implementing regulations of the U.S. Department of Labor at 29 CFR Part 5. Contractor shall provide documentation that demonstrates compliance with hour and wage requirements of this part. Such documentation shall be made available to the District for review upon request.

- 43 **FLORIDA PREFERENCE:** Pursuant to Florida Statute 287.084, award recommendations shall make appropriate adjustments to pricing when considering bids from bidders having a principal place of business outside the State of Florida. If applicable, all bidders must complete and submit the Bidder's Statement of Principal Place of Business form with the response to this solicitation. Failure to comply shall render a bid non-responsive to the terms of this solicitation. This preference does not apply to purchases using Federal Funds.

- 44 **THE U.S. DEPARTMENT OF AGRICULTURE'S "BUY AMERICAN" PROVISION:** Section 104(d) of the William F. Goodling Child Nutrition Reauthorization Act of 1998 requires schools and institutions participating in the National School Lunch Program (NSLP) and School Breakfast Program (SBP) in the contiguous United States to purchase, to the maximum extent practicable, domestic commodities or products for use in meals served under the programs. The legislation defines "domestic commodity or product" as one that is produced in the United States and is processed in the United States, **substantially** using agriculture commodities that are produced in the United States.

The word "substantially" is defined as over 51 percent of the final processed product consists of agricultural commodities that were grown domestically.

- 45 **PERSONAL INJURY AND PROPERTY DAMAGE:** The Contractor assumes any and all risk of personal injury and property damage attributable to the willful or negligent acts or omissions of the Contractor and the officers, employees, and agents thereof. The Contractor also assumes such risk with respect to the willful or negligent acts or omissions of persons subcontracting with the Contractor or otherwise acting or engaged to act at the instance of the Contractor in furtherance of this Contractor fulfilling the Contractor's obligations under this contract.

- 46 **TRADE-NAMED ITEMS:** When an item appearing in the solicitation document is listed by a registered trade name and the wording "no substitute", "spec only" or "only" is

indicated, only that trade-named item will be considered. The district reserves the right to reject products that are listed as approved and waive formalities. Should a vendor wish to have products evaluated for future solicitation consideration, please contact in writing, the Director of Purchasing. If the wording "no substitute", "spec only" or "only" does not appear with the trade name, offerors may submit prices on their trade-named item, providing they attach a descriptive label of their product to this solicitation. Sample merchandise offered hereunder as "offered equal" may be required to be submitted to the purchaser in advance of the solicitation award. Substitutions for items solicited, awarded and ordered are prohibited except as may be approved by the Director of Purchasing.

47 ADDITIONAL TERMS AND CONDITIONS

No additional terms and conditions included with the response shall be evaluated or considered; any and all such additional terms and conditions shall have no force and effect and are inapplicable to this ITB. If submitted either purposely through intent or design or inadvertently appearing separately in transmitting letters, specifications, literature, price lists, or warranties it is understood and agreed the general and special conditions in this solicitation are the only conditions applicable to this ITB and the Contractor's authorized signature affixed to the submittal signature section attests to this.



SECTION IV INSURANCE REQUIREMENTS

Insurance Requirements for Agreements Involving Information Technology

Vendor/Consultant shall procure and maintain for the duration of the contract insurance against claims for security breaches, system failures, injuries to persons, damages to software, or damages to property (including computer equipment) which may arise from or in connection with the performance of the work hereunder by the Vendor, its agents, representatives, or employees. Vendor shall procure and maintain for the duration of the contract insurance claims arising out of their services and including, but not limited to loss, damage, theft or other misuse of data, infringement of intellectual property, invasion of privacy and breach of data.

MINIMUM SCOPE AND LIMIT OF INSURANCE

Insurance: With respect to the performance of work under this agreement, Consultant shall maintain and shall require all of its subcontractors, if any, to maintain insurance as indicated below with an *A.M.* Best rating of no less than A: VII who is authorized to do business in the State of Florida.

1. **Commercial General Liability (CGL):** Insurance Services Office Form CG 00 01 covering CGL on an "occurrence" basis, including products and completed operations, property damage, bodily injury and personal & advertising injury with limits no less than \$2,000,000 per occurrence, \$3,000,000 aggregate. Such insurance shall include, but not limited to premises and operations liability, independent consultant's liability, and personal injury liability. Such insurance shall be primary and non-contributory and shall contain provision waiving subrogation against the District School Board.
2. **Automobile Liability:** insurance covering bodily injury and property damage in an amount not less than \$1,000,000 combined single limit for each occurrence. Such insurance shall include coverage for owned, hired, and non-owned.
3. **Workers' Compensation** insurance with statutory limits as required by the State of Florida. The policy shall be endorsed with the following specific language: "This policy shall not be cancelled or materially changed without first giving thirty (30) days prior written notice to the District School Board." and shall contain a provision waiving subrogation against the District School Board. If coverage is not provided, the vendor shall produce the State of Florida exemption which is for an officer of a corporation or member of a limited liability company to exclude themselves from the workers' compensation laws.
4. **Cyber Insurance** In addition to insurance required under the Agreement, Vendor shall at its sole cost and expense procure and maintain through the term of the Agreement and for two (2) years following the termination or expiration of the Agreement cyber/network privacy insurance with limits of \$5,000,000 per claim/in aggregate. Such policy shall provide coverage for disclosures and/or breaches of School District Data arising out of or relating to Vendor's Services. Such policy shall also include coverage for the costs associated with restoring lost or damaged School District Data, sending breach notifications to affected individuals, public relations expenses, fines, and penalties. Such policy shall not contain exclusions for the acts or omissions of either Vendor or School District or their respective employees, agents, subcontractors or volunteers, whether intentional or unintentional, resulting in or relating to any Use of School District Data not expressly permitted by the Agreement and this Addendum or any breach of School District Data. Vendor must notify School District at least thirty (30) days prior to the cancellation or modification of such policy.

This insurance shall be primary and not contributory. It shall name the School Board of Martin County as and additional insured.

Coverage shall be sufficiently broad to respond to the duties and obligations as is undertaken by Vendor in this agreement and shall include, but not be limited to, claims involving security breach, system failure, data recovery, business interruption, cyber extortion, social engineering, infringement of intellectual property, including but not limited to infringement of copyright, trademark, trade dress, invasion of privacy violations, information theft,



damage to or destruction of electronic information, release of private information, and alteration of electronic information. The policy shall provide coverage for breach response costs, regulatory fines and penalties as well as credit monitoring expenses.

➤ **Technology Professional Liability Errors & Omissions**

(Include this section only if vendor is providing a technology service (data storage, website designers, etc.,) or product (software providers)

Technology Professional Liability Errors and Omissions Insurance appropriate to the Consultant's profession and work hereunder, with limits not less than \$2,000,000 per occurrence. Coverage shall be sufficiently broad to respond to the duties and obligations as is undertaken by the Vendor in this agreement and shall include, but not be limited to, claims involving security breach, system failure, data recovery, business interruption, cyber extortion, social engineering, infringement of intellectual property, including but not limited to infringement of copyright, trademark, trade dress, invasion of privacy violations, information theft, damage to or destruction of electronic information, release of private information, and alteration of electronic information. The policy shall provide coverage for breach response costs, regulatory fines and penalties as well as credit monitoring expenses.

- a. The Policy shall include, or be endorsed to include, ***property damage liability coverage*** for damage to, alteration of, loss of, or destruction of electronic data and/or information "property" of the Agency in the care, custody, or control of the Vendor. If not covered under the Vendor's liability policy, such "property" coverage of the Agency may be endorsed onto the Vendor's Cyber Liability Policy as covered property as follows:

If the Vendor maintains broader coverage and/or higher limits than the minimums shown above, the Entity requires and shall be entitled to the broader coverage and/or the higher limits maintained by the contractor. Any available insurance proceeds in excess of the specified minimum limits of insurance and coverage shall be available to the Entity.

Other Insurance Provisions

The insurance policies are to contain, or be endorsed to contain, the following provisions:

Additional Insured Status

Each such comprehensive or commercial general liability and automobile liability insurance policy shall be endorsed with the following specific language:

1. District, its officers and employees, is named as additional insured for all liability arising out of the operations by or on behalf of the named insured in the performance of this Agreement.
2. The inclusion of more than one insured shall not operate to impair the rights of one insured
- 3.

Please note, if there is an insured vs. insured exclusion on the vendor's policy, carefully review with the vendor and their insurance carrier on whether being added as an additional insured onto the vendor's policy removes your organization's ability to file suit against the vendor and draw upon the policy should final adjudication in a lawsuit state that the vendor shall pay damages to your organization.

Primary Coverage

For any claims related to this contract, the **Vendor's insurance coverage shall be primary**. Coverage for commercial liability shall be at least as broad as ISO CG 20 01 04 13 as respects the Entity, its officers, officials, employees, and volunteers. Any insurance or self-insurance maintained by the Entity, its officers, officials, employees, or volunteers shall be excess of the Vendor's insurance and shall not contribute with it.

**Notice of Cancellation**

Each insurance policy required above shall state that **coverage shall not be canceled, except with notice to the Entity.**

Waiver of Subrogation

Vendor hereby grants to Entity a waiver of any right to subrogation which any insurer of said Vendor may acquire against the Entity by virtue of the payment of any loss under such insurance. Vendor agrees to obtain any endorsement that may be necessary to affect this waiver of subrogation, but this provision applies regardless of whether or not the Entity has received a waiver of subrogation endorsement from the insurer.

Self-Insured Retentions

Self-insured retentions must be declared to and approved by the Entity. The Entity may require the Vendor to provide proof of ability to pay losses and related investigations, claim administration, and defense expenses within the retention. The policy language shall provide, or be endorsed to provide, that the self-insured retention may be satisfied by either the named insured or Entity.

Claims Made Policies

If any of the required policies provide coverage on a claims-made basis:

1. The Retroactive Date must be shown and must be before the date of the contract or the beginning of contract work.
2. Insurance must be maintained and evidence of insurance must be provided **for at least three (3) years after completion of the contract of work.**
3. If coverage is canceled or non-renewed, and not **replaced with another claims-made policy form with a Retroactive Date** prior to the contract effective date, the Vendor must purchase "extended reporting" coverage for a minimum of **three (3) years** after completion of contract work.

Verification of Coverage

Vendor shall furnish the Entity with original Certificates of Insurance including all required amendatory endorsements (or copies of the applicable policy language effecting coverage required by this clause) and a copy of the Declarations and Endorsement Page of the CGL policy listing all policy endorsements to the Entity before work begins. However, failure to obtain the required documents prior to the work beginning shall not waive the Vendor's obligation to provide them. The Entity reserves the right to require complete, certified copies of all required insurance policies, including endorsements required by these specifications, at any time.

Subcontractors

Vendor shall require and verify that all subcontractors maintain insurance meeting all the requirements stated herein, and Vendor shall ensure that Entity is an additional insured on insurance required from subcontractors.

Entity reserves the right to modify these requirements, including limits, based on the nature of the risk, prior experience, insurer, coverage, or other special circumstances.



SECTION V SPECIAL CONDITIONS

5.1 QUALIFICATIONS OF BIDDERS

This ITB shall be awarded only to a responsive and responsible Bidder, qualified to provide the work specified. The Bidder should submit the following information with their bid response package to be considered responsive in order for the District to fully evaluate the firm's qualifications. Failure to fully submit the requested information may result in the bid response being considered non-responsive.

- A. No bid will be accepted from, nor will any contract be awarded to, any person who is in arrears to the District, upon any debt or contract, or who has defaulted, as surety or otherwise, upon any obligation to the District, or who is deemed irresponsible or unreliable by the Martin County School Board in its sole discretion.
- B. Firm must provide a minimum of three (3) satisfactory references of similar accounts and size within the past five (5) years; one (1) similar reference must be from a Government entity or School District (public sector entity) within the state of Florida; and provide details of scope of work, location, date of service, names, addresses and phone numbers of owners. Firm shall not include Martin County School District as a reference.
- C. Firm must provide proof to be a seller or reseller of the requested goods in the State of Florida. Firm must be registered with the State of Florida DBPR, if applicable.
- D. Firm must provide proof that their firm is registered with the Division of Corporations for the State of Florida.
- E. Firm must complete the enclosed questionnaire, which will be used to evaluate capabilities to perform the work during the contract period. The Bidder's Qualification's Questionnaire must be completed and contain sufficient and specific information which directly responds to the request. MCSD reserves the right to reject non-responsible bids, which do not provide sufficient information to evaluate the qualifications of the Contractor and where information provided does not demonstrate a proven past record (such as negative references, failure to complete projects, not having the capability to fully perform the contract requirements and lacking the integrity and reliability which will assure good-faith performance, etc.).
- F. Firm must have an established operational service location within a 150-mile radius of project, stock sufficient replacement parts to support specified warranty service, experienced and specialized in performing work specified.
- G. An assigned supervisor must be on each job at time of inspection. A Supervisor is required to have five (5) year's comparable experience with a current license. The assigned Supervisor will be responsible for overseeing all work performed. Contractor must provide trained personnel with adequate experience and skills to perform the work. Include qualifications on the Bidder's Qualification's Questionnaire in Section VII.
- H. Contractor must submit a written quality control program to include the following, to insure requirements of the contract are provided such as: record of response performance, total lapsed time from receipt of call to arrival at the job site, number of trips to the job site taken to complete each repair/installation, the number of technicians required to complete each repair.
- I. Contractor shall comply with Business Tax Receipt requirements for their business location, if required. A copy of the business tax receipt or proof of exemption must be included with the submittal package.
- J. Firm must be a Siemon Company Certified Installer (CI) certified installer, and must provide proof.
- K. The Successful Contractor shall be required to submit a performance and payment bond after award. Provide evidence confirming the firm's ability to obtain Payment and Performance Bonds for the project as detailed herein.



5.2 MEETING SCHEDULE

Questions Deadline: The Purchasing Department will receive written requests for clarification and inquiries concerning the meaning or interpretation of this ITB. Questions shall be emailed to bids@martinschools.org with reference to the ITB number in the subject for faster recognition. Only questions answered by formal written Addenda issued by the MCSD Purchasing Department shall be binding. Oral and other interpretations or clarifications shall be without legal effect. The District will respond to written inquiries, if received by no later than 2:00pm on April 21, 2022. The District shall record its responses to inquiries and any supplemental instructions in the form of a written addendum. If addenda are issued, the District **shall make every attempt to issue such** addenda at least seven (7) calendar days before the date fixed for receiving the bids.

Bid Opening: Firms desiring to provide the goods and services described above shall submit one (1) complete electronic submittal, contained in one (1) file, PDF format preferred, submitted electronically through www.DemandStar.com or bids@martinschools.org containing all of the required information on the proper forms as identified in Section VII, **no later than 2:00pm, April 28, 2022.** Bids will be opened and read in public via Zoom teleconference. It is the sole responsibility of the Bidder to assure that bids are received no later than the specified time and date.

Kick-Off Meeting: The District will schedule a kick-off meeting to initiate the expected services, introduce the project team to ensure the scope, goals, budget, timeline, and reporting through-out the contract period within fifteen (15) business days after Notice of Award.

5.3 BUSINESS OPERATIONS

Regular Working Hours: Unless otherwise directed by the designated Director, the successful Contractor(s) shall insure that the following schedule is adhered to and services as required must be scheduled to insure that all work is during normal business hours, after student dismissal, between the hours of 1:50 PM - 3:00 PM. Department will convey the work schedule at time of order placement. Contractor's service representative shall respond back to all requests for repair by phone within sixty (60) minutes.

Observed Holidays: The District also schedules non-work days throughout the calendar year. The Digital Learning Department or designee will notify the awarded Contractor of any non-work days that may affect the work schedule:

- | | |
|------------------------------|------------------------|
| New Year's Day | Martin Luther King Day |
| President's Day | Spring Break |
| Memorial Day | Independence Day |
| Labor Day | Veteran's Day |
| Thanksgiving Day & Day After | Christmas Break |

5.4 BRAND NAME SPECIFIC

Except as provided within, each bidder represents that their bid is based upon the materials and equipment as described in the bidding documents. No substitutions of equipment will be accepted due to standardization.

5.5 BADGE POLICY

This work is to take place on an active campus with active buildings around the area of work. All personnel working onsite with this project must have & wear MCSD badge at all times on the site. The Awarded Contractor must apply for the MCSD Badge and pay for all associated costs for each individual working on the project.

5.6 AWARD METHOD

The District intends to award this bid to a Primary bidder. Award of the primary will be determined in order of responsiveness, delivery, and service proposed, along with bidder's qualifications, adequate organization, and personnel to ensure prompt and efficient performance of work to the District. After the bid has been awarded, the Primary bidder will be used in every instance of ordering services as long as their firm is



capable of delivering the services in question within the time specified in this bid. If the Primary bidder is not able to deliver the services in question within the specified time, the District reserves the right to contact the secondary bidder with the subsequent lowest responsive responsible bid accordingly.

5.7 METHOD OF ORDERING

A blanket purchase order shall be issued for the term of the award. The department(s) will order requirement(s) on an "as needed" basis. All terms, conditions and prices of the bid are applicable. Only awarded bid items may be purchased on the blanket purchase order. Vendor is to take all necessary steps to insure this requirement. Invoices must reference purchase order.

5.8 QUALITY ASSURANCE & RETURNED GOODS

All material shall conform to Florida Department of Transportation Standard Specifications latest edition. The successful bidder upon receipt of a purchase order shall assure the product conveyed is of the correct quantity and meets all specifications of the bid, purchase order and order release. Material, which does not meet bid and purchase order specifications and requirements, including quality standards, shall be subject to return to the vendor, at the expense of the vendor.

5.9 PERFORMANCE

Throughout the contract period the Consultant(s) performance will be monitored by District staff. If performance fails to meet the standards specified or noncompliance with the conditions, terms, specifications and requirements of the ITB and receives an unacceptable rating, the District may without cause and without prejudice to any other right or remedy, terminate the contract whenever the District determines that such termination is in the best interest of the District. Vendor's receiving an unacceptable rating shall be served by written notice by the Procurement Department. The District shall be the sole judge of nonperformance.

5.10 STANDARDS/REGULATIONS

Manufactured items, fabricated assemblies and on-site contractor services shall comply with all applicable federal, state and local requirements. For on-site contractor services, the District reserves the right to request documentation of contractor compliance with OSHA standards to include, but not be limited to: required employee safety & health training, written safety and health programs, provision of required personal protective equipment (PPE).

5.11 IDENTIFICATION

The Contractor, Subcontractors, and their employees are required to have visible, personal identification and the vendor's company name displayed on their shirts. They will also be required to wear attire appropriate for a school environment: i.e., shirt, pants, & shoes. Clothing displaying nudity, obscene symbols, or pro-drug slogans is prohibited. The Contractor, Subcontractors, and all employees of same must check in and out at the main office before starting work during normal school hours. Before or after normal school hours, contact the on-site custodial staff.

5.12 INSPECTION OF FACILITIES

It is the bidder's responsibility to become fully informed as to the nature and extent of the work required and its relation to any other work in the area, including possible interference from other site activities. Thereby,



Contractor is responsible for confirming actual site conditions prior to starting work and assures that the work order produced will be completed as specified. **Any oral explanation provided prior to the bid opening will not be binding.**

5.13 **CONDUCT**

The Contractor acknowledges and understands that the job is being performed on public property owned by the MCSD, which may at various times during the completion of the job be occupied by students, teachers, parents, and school administrators. Accordingly, in order to secure the property, and otherwise comply with applicable law, the Contractor agrees to the following provisions, and also agrees that the failure to comply with any of these provisions may result in the termination of this Contract.

- The Contractor shall immediately remove from the job site, for the duration of the job, any person making an inappropriate religious, racial, sexual or ethnic comment, statement or gesture toward any other individual.
- The Contractor, Subcontractors, and their employees will refrain from using foul, abusive or profane language on school district property. Smoking/tobacco, firearms/weapons and illegal drugs are prohibited on school district property, including all buildings and grounds.
- The Contractor shall enforce strict discipline and good order among their employees at all times. Contractor's personnel shall have absolutely no contact with students or staff, other than administrative personnel or designated representatives, with the exception of emergency situations.
- No radios are allowed on the job site.

5.14 **POST SALE AUDIT ADJUSTMENT**

All items sold to the District, as a result of this bid, are subject to Post Sale Audit Adjustment. In the event that an audit reveals the vendor has not honored quoted pricing, price lists, or discount structures, vendor will be liable and will be invoiced and collected with (30) days for any and all overstated charges. Failure to remit may result in termination of the contract.

5.15 **ADDITIONAL DISCOUNTS/PROMOTIONS**

Should sales or manufacture promotions occur during the term of the contract that lower the price of the procured item or items, the vendor shall extend to the District the lower price offered by the manufacturers or vendors on any such promotional item. Further, any price decreases effectuated during the contract period by reason of market change, quantity discounts, rebates, or otherwise, shall be passed on to the District.

5.16 **PRODUCT RECALL**

In the event the awarded bidder receives notice that a product delivered by the awarded bidder to the District has been recalled, seized or embargoed, and/or has been determined to be misbranded, adulterated, or found to be unfit for human consumption by a packer, processor, subcontractor, retailer, manufacturer, or by any State or Federal regulatory agency, the awarded bidder shall notify the District's Purchasing Director within two business days of receiving such notice. The District's acceptance or failure to reject the affected product as non-conforming shall not in any way impact, negate, or diminish the awarded bidder's duty to notify the District's Purchasing Director that the affected product has been recalled, seized or embargoed, and/or has been determined to be misbranded, adulterated, or found to be unfit for human consumption. The form and content of such notice to the District shall include the name and description of the affected product; the approximate date the affected product was delivered to the District; the bid number; and relevant information relating to the proper handling of the affected product and/or proper disposition of the affected product by the District, if necessary to protect the health, welfare, and safety of District students or employees; and any health hazards known to the awarded bidder which may be caused or created by the affected product. The awarded bidder shall, at the option of the Purchasing Department and/or Purchasing Director, either reimburse the purchase price or provide an equivalent replacement product at no additional cost to the District. Unless it was absolutely necessary



for the District to dispose of the affected product, the awarded bidder shall be responsible for removal and/or replacement of the affected product within a reasonable time, as determined by the District, without causing significant inconvenience to the District. At the option of the District, the awarded vendor may be required to reimburse storage and/or handling fees to be calculated from time of delivery and acceptance to actual removal or disposal. The awarded vendor will bear all costs associated with the removal and proper disposal of the affected product. The failure to reimburse the purchase price and storage and/or handling fees or to remove and/or replace the affected product with an equivalent replacement within a reasonable time without significant inconvenience to the District will be considered a default.

5.17 PROTECTION OF PROPERTY

The successful Contractor shall at all times guard against damage or loss to the property of the District or that of other vendors or contractors and shall be held responsible for replacing or repairing any such loss or damage. The District may withhold payment or make such deductions, as deemed necessary, to ensure reimbursement or replacement for loss or damage to property through negligence of the successful Contractor or their agents.

The successful Contractor shall be responsible for the protection of property in the areas in the adjacent vicinity of the project; and for the protection of his own equipment, supplies, materials and work, against any damage resulting from the elements (such as flooding, rainstorms, wind damage, or other acts of God) or vandalism.

5.18 DEBRIS

Vendor shall be responsible for the prompt removal of all debris which results from the contracted service. Contractor shall be responsible to ensure frequent pick-up of all refuse, rubbish, scrap materials and debris that results from their operations so that work sites presents a neat and orderly appearance at all times. All rubbish, scrap, etc., shall be transported from the premises. NO rubbish shall be deposited on the work site. At completion of work, the Contractor shall remove all work materials, tools, equipment, machinery, and surplus materials from the work site and shall leave project in ready to use condition.

5.19 PAYMENT & PERFORMANCE BONDS

The Successful Contractor shall be required to submit a performance and payment bond after award. Provide evidence confirming the firm's ability to obtain Payment and Performance Bonds for the project as detailed herein. The successful Bidder will be required to furnish payment and performance bonds with a carrier duly licensed and authorized to do business in the State of Florida equal to one hundred percent (100%) of the total amount of the contract to assure faithful performance and timely payments to all persons providing labor, materials or supplies used in the performance of the work.



**SECTION VI
SCOPE OF WORK**

6.1 WORK OBJECTIVE

The Martin County School District (hereinafter referred to as “MCSD”) is soliciting qualified installers to submit bids to install interactive flat panels (IFP), as well as near end of life aging equipment, including repairs to existing IFPs in accordance with the specifications identified in Section IX, and able to meet the requirements of the hardware and installation variations as follows:

Interactive Flat Panels
Boxlight ProColor 753U 75 in. 4K UHD or equal model
Boxlight ProColor 863 86 in. 4K UHD or equal model
Interactive Flat Panel Installation Variations
Adjustable height Wall mount with floor support
Adjustable Height Over the rail mount
Mobile Interactive Flat Panel Cart, with Adjustable height mount

- A. **Replacement:** If interactive flat panels are defective and cannot be repaired, no longer working, or the life cycle of the panel has expired, the Contractor will be contacted to remove and replace the IFP.
 - As part of the de-installation process, the Contractor is responsible for the removal of any existing projectors, digitizer panels, interactive panels, associated mounts, poles, and cabling. Documentation of asset-tagged removed equipment must be provided to District in a format determined by District. Items to remove in a typical de-installation may include but are not limited to projector, projector mount, smartboard, mounts, mounting hardware, VCRs, and all associated wiring/cables.
- B. **Repairs:** Equipment failure will result in the awarded Contractor to provide a diagnosis and treatment for repairs to ensure equipment is operable to pass inspection. If repairs are not cost effective, Project Manager may approve direct replacement of panel.
 - Section VII, Schedule of Prices, Group C, all rates quoted shall include travel means, labor and any and all equipment and tools required. There shall be no charges to and from the work sites.
- C. **Past History:** The District installed approximately 150 IFP’s last year and anticipates the installation of approximately 300 per year during the term of this agreement.

6.2 TIME FOR COMPLETION OF SERVICES

- Each installation will be communicated with the District Digital Learning Department, site specific media specialist, and site-specific plant operator. Installations will typically take place following student dismissal. Each school site will notify the install team what time the building will close during communications.
- Contractor must have the ability to complete (5) installations simultaneously within 72 hours from order request for new installs for break replace instances.
- Contractor must have the ability to complete (25) total installations per week.



- Repair projects must be completed as quickly as reasonably possible, and be completed within the timeframe provided on estimate.

6.3 **INSPECTION AND TESTING**

All work shall be tested to ensure panel is working properly. Contractor is to demonstrate this action prior to inspection by the Digital Learning Department or designee, based on installation and functionality checklist. All repairs and/or installations with any noted deficiencies or failed inspection must be corrected before invoice(s) for payment will be processed. After diagnosis of work, technician will complete the work to ensure compliance with the terms of the bid prior to re-inspection. This work will be at no charge to the District.

6.4 **SERVICING PROCEDURES**

All schedules must be established in advance and with prior approval. All schedules and the necessary arrangements to implement the scope of work must be mutually reviewed and approved by the Contractor and Project Manager or Designee. Under no circumstances shall any delivery, installation or training be attempted prior to approval of Project Manager or designee.

On an as needed basis following failed inspection results, Contractor shall submit a written estimate of repairs necessary to achieve passing inspection results. This estimate shall include a total firm cost to the District itemized as follows; labor hours, equipment, itemization costs for material/parts, a brief description of the repair and/or replacement work to be done and location of work. Estimates must be complete and specific with measurements and quantities of time, completion, and materials. Project Manager or designee will provide Contractor with notice to proceed for commencement and approval of all work.

If new installation of IFP, Contractor shall submit a written itemized estimate with location, de-installation cost for the removal of the panel, cost of new panel, including labor, and materials necessary, and Project Manager's approval of installation.

Contractor to immediately notify the Project Manager of any costs anticipated to exceed the original estimate submitted. At which time a change order may be implemented for necessary additional costs for completion of work. Re-inspection and testing of units shall be conducted immediately following repairs/replacements at no additional charge to District. (District may request copies of manufacturer's invoices from Contractor's suppliers as proof of material cost).

If the Contractor shall be delayed in the completion of work by reason of unforeseeable causes beyond its control and without fault or negligence, including, but not restricted to, acts of God or neglect of any other contractor, the period herein specified for the completion of delivery shall be extended by such time as shall be approved by the Project Manager or designee.

Failure to obtain written approval on a quotation may result in non-payment. Contractor agrees and understands that the **contract shall not be construed as an exclusive arrangement** and further agrees that the District may, at any time, secure similar or identical services at its sole option for repair work. All repair work to be performed in the best workmanlike manner as known to the trade. All measures shall be made to have equipment operational and ready for re-inspection.

Upon completion of services, the District reserves the right to request a Supervisor to review the work performed by their technician if deemed necessary. Supervisors review to be at no additional charge to the District and considered part of the contract award. The District's Project Manager reserves the right to request the Contractor to review and provide written acknowledgement/report that work performed has been completed. Contractor's review to be at no additional charge to the District and considered part of the contract award. Contractor shall document any areas of concern that are above and beyond on their report. The report shall be signed by an authorized agent of the firm and submitted to the Project Manager by email address provided to the awarded Contractor.



Contractor must maintain complete and accurate records of all services provided pursuant to the terms of this agreement. All work-repair tickets, service calls, etc. shall be kept for auditing purposes and to be used as a work history for each of the units. Contractor shall establish a written quarterly quality control program to insure requirements of the contract are provided such as: record of response performance, total time from receipt of call to arrival at the job site, number of trips to the job site taken to complete each repair/installation, a detailed description of their diagnosis, prognosis, any materials/supplies required, and location of work.

6.5 **WORKMANSHIP**

All work shall be performed in a professional manner and shall conform to all applicable District, County, State and Federal Regulations and/or Codes. The Contractor agrees to use trained personnel with adequate experience and skills in testing, inspection and maintenance of Interactive Flat Panels in accordance with all codes and regulations as stated previously.

Contractor will be responsible for their own measurements and must submit a firm price accordingly. There will be no adjustments, for increase or decrease of the dimensions requested; therefore, the "Total Offer" must be based on accurate measurements by awarded bidder on. Failure to do so will be at the bidder's risk. Contractors furnish all parts and tools necessary to perform complete maintenance/repair services as specified in a safe manner. Repairs shall include diagnosis, removal and replacement of defective components, as service requires.

Contractor will be required to establish a written quality control program to insure requirements of the contract are provided such as: record of response performance, total lapse time from receipt of call to arrival at the job site, number of trips to the job site taken to complete each repair/installation, the number of technicians required to complete each repair.

District shall provide electronic lists of asset tag numbers, installation location, equipment to be removed, equipment to be installed, and additional notes as needed. Contractor shall provide a electronic spreadsheet detailing the IFP serial number associated with that asset tag, MAC Address, custodian and location (school, building, and classroom), on an ongoing basis within 24 hours of installation/services rendered.

6.6 **EQUIPMENT / MATERIALS / PARTS**

The scope of these specifications is to ensure the delivery of a complete unit ready for operation. Omission of any essential detail from these specifications does not relieve the supplier from the furnishing of a complete unit.

All equipment / materials must be new, of current manufacturer and in production at the time of bid opening and carry standard warranties. All equipment supplied shall contain complete maintenance instructions, operating manuals and parts lists with each type of equipment at the time of installation. The successful bidder must service all equipment upon to delivery. Equipment / materials may include, but not limited to the following:

- Boxlight [ProColor 753U](#) | 75 in. 4K UHD or newer equal model
- Boxlight [ProColor 863](#) | 86 in. 4K UHD or newer equal model
- HDMI Cables 10 ft
- HDMI Cable 50 ft
- HP Display port to HDMI adapter
- USB Super Booster Extender
- Patch cable
- IFP Wall Mount with Floor support
- IFP Mobile Mount



- IFP Over the rail mount
- Manual Adjustable tension height mount compatible with mobile, over the rail, and wall mounts(Balance box) if needed compatible VESA Adapter

Example Configurations: These are typical installation variances, but district needs are not limited to only these configurations.

Config A - 75" panel, no removal of old equipment	
<u>Description</u>	<u>QTY</u>
Boxlight ProColor 75" 4K Panel	1
Monoprice 50ft HDMI	1
BalanceBox Tensioned Wall Mount (400-90-Martin)	1
BalanceBox VESA Adapter (400-90-Martin)	1
10ft Monoprice HDMI	1
HP DisplayPort to HDMI Adapter	1
BalanceBox Floor Supports	1
Cables2Go USB Superbooster Extender	1
Installation	1
Config B - 75" panel, includes Over the Rail mount and floor support, no removal of old equipment	
<u>Description</u>	<u>QTY</u>
Boxlight ProColor 75" 4K Panel	1
Monoprice 50ft HDMI	1
BalanceBox Tensioned Wall Mount (400-90-Martin)	1
BalanceBox VESA Adapter (400-90-Martin)	1
10ft Monoprice HDMI	1
HP DisplayPort to HDMI Adapter	1
BalanceBox Floor Supports	1
Cables2Go USB Superbooster Extender	1
Diversitrack TV Mount	1
Installation	1
Config C - 75" panel, includes Over the Rail mount and floor support, no removal of old equipment	
<u>Description</u>	<u>QTY</u>
Boxlight ProColor 75" 4K Panel	1
Monoprice 50ft HDMI	1
BalanceBox Tensioned Wall Mount (400-90-Martin)	1
BalanceBox VESA Adapter (400-90-Martin)	1
10ft Monoprice HDMI	1
HP DisplayPort to HDMI Adapter	1
BalanceBox Floor Supports	1
Cables2Go USB Superbooster Extender	1
Chief Over-the-Rail Mounts	1
Installation	1



Config D - New Classroom getting Mobile Unit with 75" panel, no removal of old equipment	
<u>Description</u>	<u>QTY</u>
Boxlight ProColor 75" 4K Panel	1
15ft Cables2Go Network Cable	1
BalanceBox Mobile Stand (400-90-MOB-MARTIN)	1
BalanceBox Tensioned Wall Mount (400-90-MOB-MARTIN)	1
BalanceBox VESA Adapter (400-90-MOB-MARTIN)	1
16.4ft Cables2Go USB Cable	1
HP DisplayPort to HDMI Adapter	1
15ft Monoprice HDMI Cable	1
Installation	1

Config E - New Classroom getting Mobile Unit with 86" panel, no removal of old equipment	
<u>Description</u>	<u>QTY</u>
Boxlight ProColor 86" 4K Panel	1
15ft Cables2Go Network Cable	1
BalanceBox Mobile Stand (400-90-MOB-MARTIN)	1
BalanceBox Tensioned Wall Mount (400-90-MOB-MARTIN)	1
BalanceBox VESA Adapter (400-90-MOB-MARTIN)	1
16.4ft Cables2Go USB Cable	1
HP DisplayPort to HDMI Adapter	1
15ft Monoprice HDMI Cable	1
Installation	1

Config F - 86" panel, no removal of old equipment	
<u>Description</u>	<u>QTY</u>
Boxlight ProColor 86" 4K Panel	1
Monoprice 50ft HDMI	1
BalanceBox Tensioned Wall Mount (400-90-Martin)	1
BalanceBox VESA Adapter (400-90-Martin)	1
10ft Monoprice HDMI	1
HP DisplayPort to HDMI Adapter	1
BalanceBox Floor Supports	1
Cables2Go USB Superbooster Extender	1
Installation	1

Config G - 86" panel, includes Over the Rail mount and floor support, no removal of old equipment	
<u>Description</u>	<u>QTY</u>
Boxlight ProColor 86" 4K Panel	1
Monoprice 50ft HDMI	1
BalanceBox Tensioned Wall Mount (400-90-Martin)	1
BalanceBox VESA Adapter (400-90-Martin)	1
10ft Monoprice HDMI	1



HP DisplayPort to HDMI Adapter	1
BalanceBox Floor Supports	1
Cables2Go USB Superbooster Extender	1
Diversitrack TV Mount	1
Installation	1
Config H - 86" panel, includes Over the Rail mount and floor support, no removal of old equipment	
<u>Description</u>	<u>QTY</u>
Boxlight ProColor 86" 4K Panel	1
Monoprice 50ft HDMI	1
BalanceBox Tensioned Wall Mount (400-90-Martin)	1
BalanceBox VESA Adapter (400-90-Martin)	1
10ft Monoprice HDMI	1
HP DisplayPort to HDMI Adapter	1
BalanceBox Floor Supports	1
Cables2Go USB Superbooster Extender	1
Chief Over-the-Rail Mounts	1
Installation	1

All parts required shall be genuine parts as manufactured and distributed by the manufacturer. Only original equipment manufacturer (OEM) parts may be utilized, unless authorized by proper District personnel.

The District reserves the right to obtain parts as a direct pass-thru from other sources or may exercise the option to directly purchase equipment at District’s cost. The parts provided under this contract must be verified by the submission of an itemized list of materials proposed for purchase from the identified source, each unit priced by cost, the total price and the awardee’s cost-plus mark-up. Any remaining materials, after project completion, become the property of District. It will be the District’s responsibility to inspect and accept parts purchased by District. Contractor will only provide the services required to complete the work with the District purchased materials.

Contractor may offer quantity discounts and reduction of mark-up at their discretion. Contractor may offer reduced mark-up from amount quoted to reflect quantity discounts and or promotions from the manufacturer.

Installer shall furnish and install appropriate cables and accessories in accord with Section IX.

HDMI Cables: All display locations shall have one HDMI signal cable from the teacher/presentation location to the IFP location. Install one high quality Category 2 HDMI cable suitable for in-wall installation from the teacher/presentation location to the IFP location. In-wall cables are to be terminated on appropriate HDMI wall plate termination at teacher/presentation location and on appropriate HDMI wall plate at display location. All HDMI cables are to use Type A connectors of the appropriate gender for the location in which they are being used.

Design consideration/guideline:

Monoprice P/N: 9172 50FT HDMI ACTIVE/DIRECTIONAL CABLE

Siemon Company MAX angled connectivity products

Siemon P/N: MX-HD-XX MAX® HDMI Adapter Extender Cable, F/F



(Note XX: match color to existing wall plates in room)

Patch cables: Supply high quality Category 2 HDMI patch cables of sufficient length to connect teacher/presentation PC to AV wall plate at teacher/presentation location and from wall plate at IFP location to IFP.

Design considerations/guideline:

Monoprice P/N: 3993 10FT HDMI BI-DIRECTIONAL CABLE

USB Extenders: Shall be self powered (from USB port) and capable of extending USB V2.0 or greater a minimum of 50 feet over CAT6 twisted pair cable.

Design considerations/guideline:

C2G/LEGRAND P/N: 29352 USB Extender

DisplayPort to HDMI Adapter: Shall support DisplayPort v1.4 (minimum) and HDMI v2.0b (minimum).

Design considerations/guideline:

Hewlett Packard P/N: BP937AA DISPLAYPORT TO HDMI ADAPTER

Wall plate: The Awarded Bidder will be responsible for determining where existing infrastructure (wall outlets (data and power), wall plate covers, conduit, etc.), can be reused or if new infrastructure is needed at the teacher/presentation and IFP wall plate locations. Awarded Contractor/supervisor and Project manager or designee on an as needed basis, may schedule a time to meet at the job site, after student dismissal, to review scope prior to issuance of work order.

Teacher location, new wall plate: 2-gang wall plate shall be provided for wall outlets. Wallplate shall be one unit, permanently machined marked with jack/connector identifiers for audio and video. Wall plate shall house four (4) CAT 6 Ethernet data ports terminated on RJ45 keystone from the nearest MDF/IDF/CP, one (1) CAT 6 Ethernet data port terminated on RJ45 keystone from the IFP location to support the USB Extender, one (1) CAT 6 Ethernet data port terminated on RJ45 keystone from the Dome Sensor location to support the Audio Enhancement wireless microphones, one (1) HDMI port terminated on a Type 2 HDMI connector from the IFP, four (4) speaker level audio connectors (RCA) for ceiling speakers. Where in-wall cable runs are not possible, surface mount raceway is acceptable

Design considerations:

Siemon Company MAX angled connectivity products

Siemon P/N: MX-HD-XX MAX® HDMI Adapter Extender Cable, F/F

(Note XX: match color to existing wall plates in room)

Wiremold 2400 and 2900 white SM raceway products

Teacher location, existing wall plate: Existing wall plate should be updated accordingly to meet the following requirements: Wallplate shall be one unit, permanently machined marked with jack/connector identifiers for audio and video. Wall plate shall house four (4) CAT 6 Ethernet data ports terminated on RJ45 keystone from the nearest MDF/IDF/CP, one (1) CAT 6 Ethernet data port terminated on RJ45 keystone from the IFP location to support the USB Extender, one (1) CAT 6 Ethernet data port terminated on RJ45 keystone from the Dome Sensor location to support the Audio Enhancement wireless microphones, one (1) HDMI port terminated on a Type 2 HDMI connector from the IFP, four (4) speaker level audio connectors (RCA) for ceiling speakers. Where in-wall cable runs are not possible, surface mount raceway is acceptable

Design considerations:

Siemon Company MAX angled connectivity products

Siemon P/N: MX-HD-XX MAX® HDMI Adapter Extender Cable, F/F

(Note XX: match color to existing wall plates in room)

Wiremold 2400 and 2900 white SM raceway products

IFP location, new wall plate: Single-gang wall plate shall be provided for wall outlets. Wallplate shall be one unit, permanently machined marked with jack/connector identifiers for audio and video. Wall plate shall house two (2) CAT 6 Ethernet data ports terminated on RJ45 keystone from the nearest MDF/IDF/CP, one (1) CAT 6 Ethernet data port terminated on RJ45 keystone from the teacher/presentation location to support the USB Extender, one (1) HDMI port terminated on a Type 2



HDMI connector from the teacher/presentation location. Where in-wall cable runs are not possible, surface mount raceway is acceptable. Should be placed directly behind footprint of new IFP.

Design considerations:

Siemon Company MAX angled connectivity products

Siemon P/N: MX-HD-XX MAX® HDMI Adapter Extender Cable, F/F

(Note XX: match color to existing wall plates in room)

Wiremold 2400 and 2900 white SM raceway products

Cable Marker Labels: Labels shall be machine printed or typed and permanently attached to cables.

6.7 **ASSEMBLY AND/OR PLACEMENT**

It will be the responsibility of the vendor to supply the necessary labor and materials for the site placement of all equipment as specified herein. Equipment is to be set-up, checked out and demonstrated at no charge. All equipment supplied shall contain complete maintenance instructions, operating manuals and parts list.

6.8 **COOPERATION WITH DISTRICT**

District reserves the right to supervise all services, repairs and/or installation required under this contract and to provide the requisite parts from District stock. District also reserves the right to have District personnel assist and work together with Contractor's personnel when it is deemed in the best interest of District. This Special Condition will NOT void ANY warranty provisions or ITB Specifications stated in this document, including the one-year "on-site" warranty for parts and labor while working in cooperation with District authorized personnel.

6.9 **WARRANTY**

Should any defect in materials or workmanship, excepting ordinary wear and tear, appear during the below stated warranty period, the successful bidder shall repair or replace same at no cost to the District:

- A. **Installation:** The successful bidder shall warranty all workmanship/labor for a period of 12 months from date of completion and final acceptance by the Digital Learning Department or designee. Should any defect in workmanship, excepting ordinary wear and tear, appear during the above stated warranty period, the successful bidder shall repair or replace same at no cost to the District, immediately upon written notice from the Digital Learning Department or designee.
- B. **Parts:** The successful bidder shall provide full factory warranty on all new parts. The factory warranty shall become effective on the date of installation.
- C. **IFP/Hardware:** Hardware is defined as the panel, stand/mount, stand accessories and height adjustment mechanism, including online and phone support for a minimum of seven (7) years.
- D. **Software:** Warranty should consist of free upgrades for a minimum of ten (10) years.

6.10 **PRICING AND INVOICING**

- A. The District requires a firm price for each contract period. Invoices will be checked to confirm compliance with quoted pricing. Failure to hold prices firm through each contract term will be grounds for contract termination.
- B. Each service call shall be invoiced separately for repairs. The invoice shall reflect the hourly labor rate for repairs, and number of hours on-site with a separate itemized listing of the materials, (if applicable) shall mirror work ticket. For invoices involving materials, copies of list/catalog price shall be submitted for verification. Failure to supply copies of invoices may result in contract cancellation.
- C. Invoices submitted for new installs shall reflect/mirror estimate for deinstallation, installation cost per panel. There will be no additional charges for mileage and/or travel time.



6.11 SAMPLE FORMS

The District is hereby requesting sample(s) of the following to be submitted with bid response:

- Work Order/Work-Repair Ticket
- Invoice



SECTION VII FORMS

INVITATION TO BID (ITB) NO. 1013-0-2022/LD

**PURCHASE AND INSTALLATION OF
INTERACTIVE FLAT PANELS (IFP)**

**PURCHASING DEPARTMENT
2845 SE DIXIE HWY
STUART, FLORIDA, 34997
TELEPHONE (772) 219-1255
EMAIL bids@martinschools.org**



**SECTION VII
FORMS**

- 7.1 COVER PAGE CHECKLIST
- 7.2 BID FORM
- 7.3 SCHEDULE OF PRICES
- 7.4 BIDDER'S QUALIFICATION'S QUESTIONNAIRE
- 7.5 SUBCONTRACTOR LIST
- 7.6 WARRANTIES
- 7.7 REFERENCE QUESTIONNAIRE
- 7.8 NON-COLLUSIVE AFFIDAVIT
- 7.9 CONFLICT OF INTEREST
- 7.10 DRUG FREE WORKPLACE
- 7.11 PUBLIC ENTITY CRIMES
- 7.12 NO BID



COVER PAGE CHECKLIST

THIS SHOULD BE THE FIRST PAGE OF YOUR SUBMITTAL

SOLICITATION NAME:

SOLICITATION NO:

COMPANY NAME:

PHONE NO:

- 1. Submit one (1) complete electronic submittal, contained in one (1) file, PDF format preferred, submitted electronically through www.DemandStar.com or bids@martinschools.org containing all of the required information **prior to the Bid deadline.** Bids submitted after the bid deadline shall be retained unopened and deemed non-responsive.
- 2. Bid Form: **Carefully read and properly complete the Bid Form.** *(Failure to properly complete and submit this document may cause the Bid submittal to be rejected as non-responsive.)*
- 3. Schedule of Bid Prices/Bid Submittal Certification: **Carefully read all Bid Documents, and properly complete the Bid Schedule and execute the certification.** *(Failure to properly complete and sign this document shall cause the Bid submittal to be rejected as non-responsive.)*
- 4. Bidder's Qualification Questionnaire: **Complete and sign the Bidder's Qualification Questionnaire.** *(Failure to properly complete and sign this document shall cause the Bid submittal to be rejected as non-responsive.)*
- 5. Subcontractor List: **Complete the form.**
- 6. Warranties: **Complete and sign the Warranties form**
- 7. References: **Complete and submit three references on the designated Form.**
- 8. Non-Collusion Affidavit: Sign the Non-Collusion Affidavit and have it notarized.
- 9. Conflict of Interest: Complete and sign the form.
- 10. Drug Free WorkPlace Form: **Sign the Drug Free WorkPlace Form**
- 11. Public Entity Crime Statement: Sign the Public Entity Crime Statement and have it notarized.
- 12. Proof of Insurance: Include proof of insurance containing **a provision or endorsement that the coverage afforded will not be canceled, reduced in coverage, or renewal refused until at least 30 days' prior written notice has been given to the DISTRICT and additional insured by certified mail. All such insurance required herein (except for worker's compensation and employer's liability) shall name the DISTRICT, and their officers, directors, agents, and employees as "additional insured".** Attach to the back of your submittal.
- 13. Licenses: **Attach certificate of competency, state registration and any other applicable licenses.** Attach to the back of your submittal.
- 14. **Proof that firm is registered with Florida Division of Corporations (Sunbiz) and Business Tax Receipt, if applicable.**
- 15. **IF "NO BID" is offered, please complete the last section in the Bid Form and return to the Purchasing Department.**



BID FORM

SOLICITATION NAME:

SOLICITATION NO:

Submitted By:

(BIDDER)

Date:

A. SCOPE OF WORK

The scope of work as identified in Section VI, and in accordance with the Specifications.

B. BIDDER ACKNOWLEDGES

- 1. The undersigned BIDDER proposes and agrees, if this Bid is accepted, to enter into an Contract with the DISTRICT to perform and furnish all WORK and deliver all materials in accordance with the bid documents as specified herein for the Contract Price and within the Contract Period indicated in this Bid.
- 2. This Bid will remain subject to acceptance for ninety (90) days after the day of Bid opening. BIDDER will sign and submit the necessary documents required by the DISTRICT within ten (10) days after the date of DISTRICT'S Notice of Award.
- 3. In submitting this Bid, BIDDER represents, as more fully set forth in the Contract, that;

a. BIDDER has examined the Bid Documents, including the following addenda, receipt of which is hereby acknowledged:

Number	Date	Number	Date	Number	Date
--------	------	--------	------	--------	------

- b. BIDDER has familiarized itself with the nature and extent of the Bid Documents, locality, and all local conditions and laws and regulations that in any manner may affect cost, progress, performance or furnishing of the WORK. These General Conditions are applicable to all specifications contained in the project manual.
- c. BIDDER has given the DISTRICT written notice of all conflicts, errors or discrepancies that it has discovered in the Bid Documents and the written resolution thereof by the DISTRICT is acceptable to BIDDER.

4. BIDDER proposes to furnish the WORK in conformity with the specifications and at the Bid Prices referenced below in the Schedule of Bid Prices. The Bid Prices quoted have been checked and certified to be correct. Said Bid Prices are fixed and firm and shall be paid to BIDDER for the successful completion of its obligation as specified in the Bid Documents.

5. Provide office hours and contact information of staff responsible for coordination of services. _____

Contact Person

Business Address

City, State, Zip Code

Business Phone No.

Fax No.

Cell Phone No.



6. Other pertinent information is as follows:

License No.
(Attach Copy)

Federal Tax ID No.

Federal Employment ID No.

7. List a summary of Dispatch methods used during normal business hours and after hours (radio, beepers, cellular phones etc.). _____

8. List a summary of Fleet utilized for this bid (Quantity, model and year)._____

9. Include or attach (in detail) Contractor's safety program_____

10. Principal Office Location contiguous of Martin County – Location of principal office, which will be responsible for implementation of this contract. Please list telephone number (s), facsimile number (s) and email address (s).

11. Other Office Locations – Location of other offices from which resources may be drawn.



SCHEDULE OF PRICES

Award is based on the lowest responsive responsible bidder's Overall Grand Total for Groups A & B only, including, all profit and overhead, travel means, incidentals, supervision, equipment, tools, materials, cleanup and other means to successfully complete the services herein.

GROUP A1			
75" Panel Wall Mount			
Item#	Qty	Description	Unit Price
1	1	Boxlight ProColor 75" 4K Panel	\$
2	1	Monoprice 50ft HDMI	\$
3	1	BalanceBox Tensioned Wall Mount (400-90-Martin)	\$
4	1	BalanceBox VESA Adapter (400-90-Martin)	\$
5	1	10ft Monoprice HDMI	\$
6	1	HP DisplayPort to HDMI Adapter	\$
7	1	BalanceBox Floor Supports	\$
8	1	Cables2Go USB Superbooster Extender	\$
Group A1 - Total (Item #'s 1 + 8 =)			\$
GROUP A2			
75" Panel, includes Over the Rail Mount and Floor Support			
Item#	Qty	Description	Unit Price
1	1	Boxlight ProColor 75" 4K Panel	\$
2	1	Monoprice 50ft HDMI	\$
3	1	BalanceBox Tensioned Wall Mount (400-90-Martin)	\$
4	1	BalanceBox VESA Adapter (400-90-Martin)	\$
5	1	10ft Monoprice HDMI	\$
6	1	HP DisplayPort to HDMI Adapter	\$
7	1	BalanceBox Floor Supports	\$
8	1	Cables2Go USB Superbooster Extender	\$
9	1	Diversitrack TV Mount	\$
Group A2 - Total (Item #'s 1 + 9 =)			\$



GROUP A3 A3 - 75" panel, includes Over the Rail Mount and Floor Support			
Item#	Qty	Description	Unit Price
1	1	Boxlight ProColor 75" 4K Panel	\$
2	1	Monoprice 50ft HDMI	\$
3	1	BalanceBox Tensioned Wall Mount (400-90-Martin)	\$
4	1	BalanceBox VESA Adapter (400-90-Martin)	\$
5	1	10ft Monoprice HDMI	\$
6	1	HP DisplayPort to HDMI Adapter	\$
7	1	BalanceBox Floor Supports	\$
8	1	Cables2Go USB Superbooster Extender	\$
9	1	Chief Over-the-Rail Mounts	\$
Group A3 - Total (Item #'s 1 + 9 =)			\$
GROUP A4 New Classroom Getting Mobile Unit with 75" Panel			
Item#	Qty	Description	Unit Price
1	1	Boxlight ProColor 75" 4K Panel	\$
2	1	15ft Cables2Go Network Cable	\$
3	1	BalanceBox Mobile Stand (400-90-MOB-MARTIN)	\$
4	1	BalanceBox Tensioned Wall Mount (400-90-MOB-MARTIN)	\$
5	1	BalanceBox VESA Adapter (400-90-MOB-MARTIN)	\$
6	1	16.4ft Cables2Go USB Cable	\$
7	1	HP DisplayPort to HDMI Adapter	\$
8	1	15ft Monoprice HDMI Cable	\$
Group A4 - Total (Item #'s 1 + 8 =)			\$



GROUP A5 New Classroom Getting Mobile Unit with 86" Panel			
Item#	Qty	Description	Unit Price
1	1	Boxlight ProColor 86" 4K Panel	\$
2	1	15ft Cables2Go Network Cable	\$
3	1	BalanceBox Mobile Stand (400-90-MOB-MARTIN)	\$
4	1	BalanceBox Tensioned Wall Mount (400-90-MOB-MARTIN)	\$
5	1	BalanceBox VESA Adapter (400-90-MOB-MARTIN)	\$
6	1	16.4ft Cables2Go USB Cable	\$
7	1	HP DisplayPort to HDMI Adapter	\$
8	1	15ft Monoprice HDMI Cable	\$
Group A5 - Total (Item #'s 1 + 8 =)			\$
GROUP A6 86" Panel Wall Mount			
Item#	Qty	Description	Unit Price
1	1	Boxlight ProColor 86" 4K Panel	\$
2	1	Monoprice 50ft HDMI	\$
3	1	BalanceBox Tensioned Wall Mount (400-90-Martin)	\$
4	1	BalanceBox VESA Adapter (400-90-Martin)	\$
5	1	10ft Monoprice HDMI	\$
6	1	HP DisplayPort to HDMI Adapter	\$
7	1	BalanceBox Floor Supports	\$
8	1	Cables2Go USB Superbooster Extender	\$
Group A6 - Total (Item #'s 1 + 8 =)			\$



GROUP A7 86" Panel, includes Over the Rail Mount and Floor Support			
Item#	Qty	Description	Unit Price
1	1	Boxlight ProColor 86" 4K Panel	\$
2	1	Monoprice 50ft HDMI	\$
3	1	BalanceBox Tensioned Wall Mount (400-90-Martin)	\$
4	1	BalanceBox VESA Adapter (400-90-Martin)	\$
5	1	10ft Monoprice HDMI	\$
6	1	HP DisplayPort to HDMI Adapter	\$
7	1	BalanceBox Floor Supports	\$
8	1	Cables2Go USB Superbooster Extender	\$
9	1	Diversitrack TV Mount	\$
Group A7 - Total (Item #'s 1 + 9 =)			\$
GROUP A8 86" Panel, includes Over the Rail Mount and Floor Support			
Item#	Qty	Description	Unit Price
1	1	Boxlight ProColor 86" 4K Panel	\$
2	1	Monoprice 50ft HDMI	\$
3	1	BalanceBox Tensioned Wall Mount (400-90-Martin)	\$
4	1	BalanceBox VESA Adapter (400-90-Martin)	\$
5	1	10ft Monoprice HDMI	\$
6	1	HP DisplayPort to HDMI Adapter	\$
7	1	BalanceBox Floor Supports	\$
8	1	Cables2Go USB Superbooster Extender	\$
9	1	Chief Over-the-Rail Mounts	\$
Group A8 - Total (Item #'s 1 + 9 =)			\$
GROUP A1-A8 = TOTAL (A1+A2+A3+A4+A5+A6+A7+A8) = GRAND TOTAL			\$



GROUP B - Labor				
Item#	Qty	Description	Unit Price Per Panel	Annual Total
B1	300	De-Installation	\$	\$
B2	300	Installation	\$	\$
GROUP B – GRAND TOTAL				\$
If you are not the successful bidder awarded as primary provider, would you accept serving as the secondary (backup) provider, with the same terms and conditions as your bid? <input type="checkbox"/> Yes <input type="checkbox"/> No				
OVERALL GRAND TOTAL (A + B=)				\$
GROUP C - Repair Parts & Labor				
First Hour Labor Rate for Repairs			\$	
Hourly Labor Rate for Repairs			\$	
½ Hour Labor Rate for Repairs			\$	
Not to Exceed 20% Mark Up of Cost for Parts& Materials				

ALL LINE ITEMS MUST ADD UP TO THE TOTAL COST OF THAT SECTION AND TOTAL COST OF THE BID SUBMITTAL

Submitted on this day of , 2022.

a. (If an individual, partnership, or non-incorporated organization)

Signature of BIDDER

By

b. (If a corporation)

(Affix Seal)

Signature of BIDDER

By

Attested By Secretary

Incorporated under the laws of the State of Florida.

BID PRICES WITHOUT THE MANUAL SIGNATURE OF AN AUTHORIZED AGENT OF THE BIDDER SHALL BE REJECTED AS NON-RESPONSIVE, NON-CONFORMING AND INELGIBLE FOR AWARD.



CERTIFICATE
(For Partnership)

I HEREBY CERTIFY that a meeting of the partners of _____, a Partnership under the laws of the State of _____ held on _____, 2022, the following resolution was duly passed and adopted:

"RESOLVED, that _____ as _____ of the Partnership, is hereby authorized to execute the Bid Form dated _____, 20____, between the Martin County School District, Florida, and this Partnership, and that the execution thereof, attested by the _____ of the Partnership be the official act and deed of this Partnership."

I further certify that said resolution is now in full force and effect.

IN WITNESS WHEREOF, I have hereunto set my hand this _____ day of _____, 2022.

Signature

Title

STATE OF FLORIDA

COUNTY OF _____

Sworn to and subscribed before me on this _____ day of _____, 2022 by _____ who is personally known to me or who has presented the following type of identification:

_____.

Signature of Notary Public, State of Florida

Notary seal (stamped in black ink)

OR

Printed, typed or stamped name of Notary and Commission Number



CERTIFICATE
(For Corporation)

I HEREBY CERTIFY that a meeting of the Board of Directors of _____, a corporation under the laws of the State of _____ held on _____, 2022, the following resolution was duly passed and adopted:

"RESOLVED, that _____, as _____ of the Corporation, is hereby authorized to execute the Bid Form dated _____, 20____, between the Martin County School District, Florida, and this Corporation, and that the execution thereof, attested by the Secretary of the Corporation and with corporate seal affixed, shall be the official act and deed of this Corporation".

I further certify that said resolution is now in full force and effect.

IN WITNESS WHEREOF, I have hereunto set my hand this ____ day of _____, 2022.

Secretary

STATE OF FLORIDA

COUNTY OF _____

Sworn to and subscribed before me on this ____ day of _____, 2022 by _____ who is personally known to me or who has presented the following type of identification: _____.

Signature of Notary Public, State of Florida

Notary seal (stamped in black ink)
OR
Printed, typed or stamped name of Notary and
Commission Number



INTERACTIVE FLAT PANEL SPECIFICATION

ITEM	SPECIFICATION	LIST SPECIFICATION
Backlight	Light Emitting Diode (LED)	
Resolution	Minimum 4K (3840 x 2160 pixels)	
Screen Size	Minimum 75"	
Refresh Rate	Minimum 60Hz	
Viewing Angle	Minimum 178°	
Touch Points	Minimum 10	
Touch Technology	Infrared or Capacitive	
AV Inputs	USB, Display Port, and HDMI	
UL/ANSI	Certifications Required	
Requires Driver Installed on PC	No	
On-Board Integrated OS	Android	
Network	Integrated Onboard Wireless (802.11N-AC)	
Compatible with:	Windows 7-10 OS Chrome ActivInspire SMART Notebook ClassFlow	
Features of Android OS	<ol style="list-style-type: none"> 1. On-screen annotation 2. Instant whiteboard w/ multiple pen styles/ colors 3. Ability to save whiteboards/annotations to Google Drive 4. Screen mirroring (preferred, not required) 	
Stands/Mounts Types of Stands/Mount	Wall Mount (Adjustable), Mobile (Adjustable)	
Interactive Flat Panel Accessories Accessories	2 Stylus/Pens Remote Control with AV Freeze function	



CERTIFICATE
(For Partnership)

I HEREBY CERTIFY that a meeting of the partners of _____, a Partnership under the laws of the State of _____ held on _____, 2022, the following resolution was duly passed and adopted:

"RESOLVED, that _____ as _____ of the Partnership, is hereby authorized to execute the Bid Form dated _____, 20____, between the Martin County School District, Florida, and this Partnership, and that the execution thereof, attested by the _____ of the Partnership be the official act and deed of this Partnership."

I further certify that said resolution is now in full force and effect.

IN WITNESS WHEREOF, I have hereunto set my hand this _____ day of _____, 2022.

Signature

Title

STATE OF FLORIDA

COUNTY OF _____

Sworn to and subscribed before me on this _____ day of _____, 2022 by _____ who is personally known to me or who has presented the following type of identification:

_____.

Signature of Notary Public, State of Florida

Notary seal (stamped in black ink)

OR

Printed, typed or stamped name of Notary and Commission Number



CERTIFICATE
(For Corporation)

I HEREBY CERTIFY that a meeting of the Board of Directors of _____, a corporation under the laws of the State of _____ held on _____, 2022, the following resolution was duly passed and adopted:

"RESOLVED, that _____, as _____ of the Corporation, is hereby authorized to execute the Bid Form dated _____, 20____, between the Martin County School District, Florida, and this Corporation, and that the execution thereof, attested by the Secretary of the Corporation and with corporate seal affixed, shall be the official act and deed of this Corporation".

I further certify that said resolution is now in full force and effect.

IN WITNESS WHEREOF, I have hereunto set my hand this ____ day of _____, 2022.

Secretary

STATE OF FLORIDA

COUNTY OF _____

Sworn to and subscribed before me on this ____ day of _____, 2022 by _____ who is personally known to me or who has presented the following type of identification: _____.

Signature of Notary Public, State of Florida

Notary seal (stamped in black ink)
OR
Printed, typed or stamped name of Notary and
Commission Number



BIDDER'S QUALIFICATION'S QUESTIONNAIRE

THE UNDERSIGNED GUARANTEES THE TRUTH AND ACCURACY OF ALL STATEMENTS AND ANSWERS HEREIN CONTAINED:

GENERAL INFORMATION: Contractor shall furnish the following information. Information provided shall fully explain the firm's qualifications and experience of their Organization. Failure to comply with this requirement will render submittal non-responsive and shall cause its rejection. **Additional sheets can be attached as required.**

1. Contractor's Name, Principal Address, Phone Number, Fax Number, and email address as follows:

Contractor's Name and Principal Address: _____

Contact Person's Name and Title: _____

Contractor's Telephone, _____ Fax Number: _____

Contractor's Email address: _____

Contractor's License Number: _____

(Please attach certificate of status, competency, and/or state registration.)

Certification: MBE SFDB MWBE DVBE SBA Other
(Please attach certificate)

Contractor's Federal Identification Number: _____

2. Number of years your organization has been in business _____

State the number of years your firm has been in business under your present business name _____

State the number of years your firm has been in business in the work specific to this solicitation: _____

Names and titles of all officers, partners or individuals doing business under trade name:

3. How many years under a previous business name? List name(s) below.

4. Type of Business:

Sole Proprietorship Partnership Corporation Joint Venture

If a Corporation, answer this: _____

If a Partnership or Individual Proprietorship, answer this: _____

Date of incorporation: _____

Date of organization: _____

In what State: _____

If a partnership, state whether partnership is general, limited association: _____



5. Names and titles of all officers, partners or individuals doing business under trade name:

Name of Officers	Name and Address of Partners:
President:	
Vice President:	
Vice President:	
Secretary:	
Treasurer:	

**SUBSIDIARY OR AFFILIATED COMPANIES
IN WHICH PRINCIPALS HAVE FINANCIAL INTEREST**

NAME AND ADDRESS OF SUBSIDIARY OR AFFILIATED COMPANIES	EXPLAIN IN DETAIL THE PRINCIPAL'S INTEREST IN THIS COMPANY AND NATURE OF BUSINESS

6. Business Structure – Corporation, Joint Venture, or Partnership. Applicants submitting applications as joint ventures, shall submit a copy of their joint venture agreement. If a joint venture or prime/subcontractor arrangement of two (2) firms, indicate how the work will be distributed between the partners.

Business Structure	Indicate By (X)	Copy of Joint Venture Agreement Attached (Y/N)	If applicable, how will work be distributed between partners?
Corporation			
Joint Venture			
Partnership			

Length of time in business for separate Firms of a Joint Venture

Firm(s) Name	Length of Time in Business



7. Firm is a certified Minority Business Enterprise as defined in Florida Statute 287.09431, and proof is attached.
Yes No

8. Have you, in the previous five years, been denied a contract award on which you submitted the low bid in competitive bidding, or been refused prequalification? If so, please list and describe

9. Within the previous 5 years has your organization or predecessor organizations ever failed to complete a project? If so, state name of organization and reason thereof.

10. Within the previous 5 years has your organization been involved in litigation? If so, please list and explain nature and current status or resolution

11. Within the last 10 years has your organization been convicted of a Public Entity Crime? If so, please explain.

12. Is your organization currently pre-qualified with any governmental agency? If so, please list.

13. Name, address, and telephone number of surety company and agent who will provide the required bonds on this contract:

14. Have the Surety Company who will provide your bonds (said Surety Company must have an AM Best rating of Class XI A or better per the Supplementary Conditions, Section IV), provide you with written verification showing that your firm will be bonded for the amount of the contract. This must be submitted with your bid.

15. List the pertinent experience of the key individuals of your organization assigned to this project (continue on insert sheet, if necessary).

LICENSE/CERTIFICATIONS	HOW LONG WITH PRESENT FIRM	YEARS OF EXPERIENCE	IN WHAT CAPACITY AREA OF RESPONSIBILITY
------------------------	----------------------------	---------------------	---

TECHNICIAN - ASSIGNED SUPERVISOR/OBTAINED LICENSE	YEARS OF MANAGEMENT EXPERIENCE	YEARS OF EXPERIENCE	IN WHAT CAPACITY, AREA OF RESPONSIBILITY
---	--------------------------------	---------------------	--



16. List your firm, licensing, type of work licensed for, and also the licensing and types of technicians, laborers, installers.

Name	License#	Type of Work
_____	_____	_____
_____	_____	_____
_____	_____	_____

17. List and describe all bankruptcy petitions (voluntary or involuntary) which have been filed by or against the Proposer, its parent or subsidiaries or predecessor organizations during the past five (5) years. Include in the description the disposition of each such petition.

18. List and describe all successful Bond claims made to your surety (ies) during the last five (5) years. The list and descriptions should include claims against the bond of the Proposer and its predecessor organization(s).

19. List all claims, arbitrations, administrative hearings and lawsuits brought by or against the Bidder or its predecessor organizations(s) during the three (3) years. The list shall include all case names; case, arbitration or hearing identification case or file numbers; the name of the engagement over which the dispute arose; and a description of the subject matter of the dispute, and the status or disposition of the reported action. For joint venture or team Bidders, submit the requested information for each member of the joint venture or team. Use additional paper if necessary.

20. List and describe all criminal proceedings or hearings concerning business related offenses in which the Bidder, its principals or officers or predecessor organization(s) were defendants.

21. Has the Firm, its principals, officers or predecessor organization(s) ever filed for bankruptcy? If so, provide details.

The Firm acknowledges and understands that the information contained in response to this Qualification's Questionnaire shall be relied upon by DISTRICT in awarding the contract and such information is warranted by Firm to be true. The discovery of any omission or misstatement that materially affects the Firm's qualifications to perform under the contract shall cause the DISTRICT to reject the Bid, and if after the award, to cancel and terminate the award and/or contract.

The Firm also acknowledges that all information listed above may be checked by the DISTRICT and authorizes all entities or persons listed above to answer any and all questions. Firm hereby indemnifies the DISTRICT and persons or entities listed above and hold them harmless from any claim arising from such authorization or the exercise thereof, including the dissemination of information requested above.

Print Name/Title

Date:

Signature

Email:



WARRANTIES

In consideration of, and to induce the Award of **THE MARTIN COUNTY SCHOOL DISTRICT**, Construction Contract described in these Bid Documents, the Contractor represents and warrants to the Martin County School District:

1. The Contractor is financially solvent and sufficiently experienced and competent to perform all of the work required of the Contractor in the Construction Contract; and
2. That the facts stated in the Contractor's Bid and information given the Contractor pursuant to the request or proposal for Bids, instructions to Contractors and Specifications are true and correct in all respects; and
3. That the Contractor has read and complied with all of the requirements set forth in the request for Bids, instructions to Contractors and Specifications; and
4. That the Contractor warrants all materials supplied by it under the terms of the Construction Contract are delivered to the Martin County School District, free from any security interest, and other lien, and that the Contractor is a lawful owner having the right to sell the same and will defend the conveyance to the Martin County School District, against all persons claiming the whole or any part thereof; and
5. That the materials supplied to the Martin County School District, under the Construction Contract are free from the rightful claims of any persons whomsoever, by way of patent or trademark infringement or the like; and
6. That the materials supplied under the Construction Contract are merchantable within the meaning of the Uniform Commercial Code Section 2-314; and
7. That the materials supplied under the Construction Contract are free from defects in materials and workmanship under normal use and service and that any such materials found to be defective shall be replaced by the Contractor as per the attached Warranty.
8. That the materials supplied pursuant to the Construction Contract are fit for the purposes for which they are intended to be used; that under normal use and maintenance the material will continue to be fit for such purposes for the warranty period after delivery, provided that the District shall give the Contractor notice that the materials failed to fulfill the warranty; such notice shall state in what respect the materials have failed to fulfill the warranty, where upon the Contractor shall be allowed a reasonable time after receipt of such notice to correct the defect and the District agrees to cooperate in this regard. If the materials cannot be made to fulfill the Contract within the warranty period the Contractor will either furnish duplicate materials, or at its option refund the amount paid, which shall constitute a settlement in full for all damages occasioned by reason at this warranty of fitness; and
9. That this Warranty is included in exposures for which the Contractor has products liability and completed operations insurance, in minimum amounts of One Hundred Thousand (\$100,000.00) Dollars for property damage and Two Hundred Thousand (\$200,000.00) Dollars for personal injury as shown on the Certificates of such Insurance attached hereto, and the Contractor agrees to keep such insurance coverage during the period of this Warranty; and
10. That it is an express condition of this Warranty that the item(s) hereby warranted shall be operated and maintained by the District in accordance with the manufacturer's recommendations as to those portions of the item(s) that are not fabricated by the Contractor, and in accordance with the Contractor's recommendations, a copy of which has either been supplied to the District should maintain complete and accurate records made at the time of performance of maintenance showing compliance with such instructions, and by acceptance of this Warranty, the Martin County School District, agrees to present such records to the Contractor upon request in the event of a claim hereunder by the District;



- 11. The foregoing Warranties apply as a minimum and are supplemental to other Warranties offered. They are not substituted, but in addition to, any other Warranties offered; and
- 12. That it is agreed and understood by the Contractor that the Martin County School District, is induced to enter the Construction Contract in reliance upon this Warranty.

SIGNED, sealed and delivered on this ____ day of _____, 20____.

(SEAL)

CONTRACTOR:

By _____

ATTEST:

Secretary



REFERENCE FORM

Contractor must provide a minimum of three (3) satisfactory references of similar accounts and size within the past five (5) years; one (1) similar reference must be from a Government entity or School District (public sector entity) within the state of Florida; and provide details of scope of work, location, date of service, names, addresses and phone numbers of owners.

#1 REFERENCE

Company/Entity Name:	
Address - City, State Zip Code	
Contact Name: Title:	
Phone No: Fax: Email:	
Date of Service or Contract Period: Location	
Summary of Services Performed Governmental or Private	
Dollar Value of Contract	\$

#2 REFERENCE

Company/Entity Name:	
Address - City, State Zip Code	
Contact Name: Title:	
Phone No: Fax: Email:	
Date of Service or Contract Period: Location	
Summary of Services Performed Governmental or Private	
Dollar Value of Contract	\$

#3 REFERENCE

Company/Entity Name:	
Address - City, State Zip Code	
Contact Name: Title:	
Phone No: Fax: Email:	
Date of Service or Contract Period: Location	
Summary of Services Performed Governmental or Private	
Dollar Value of Contract	\$



NON-COLLUSIVE AFFIDAVIT

STATE OF FLORIDA

COUNTY OF _____

_____ being first duly sworn, deposes and says that:

BIDDER is the _____,
(Owner, Partner, Officer, Representative or Agent)

BIDDER is fully informed respecting the preparation and contents of the attached BID and of all pertinent circumstances respecting such BID;

Such BID is genuine and is not a collusive or sham BID;

Neither the said BIDDER nor any of its officers, partners, owners, agents, representative, employees or parties in interest, including this affidavit, have in any way colluded, conspired, connived or agreed, directly or indirectly, with any other BIDDER, firm or person to submit a collusive or sham BID in connection with the Contract for which the attached BID has been submitted; or to refrain from bidding in connection with such Contract; or have in any manner, directly or indirectly, sought by agreement or collusion, or communications, or conference with any BIDDER, firm, or person to fix the price or prices in the attached BID or any other BIDDER, or to fix any overhead, profit, or cost element of the BID Price or the BID Price of any other BIDDER, or to secure through any collusion conspiracy, connivance, or unlawful agreement any advantage against (Recipient), or any person interested in the proposed Contract;

The price of items quoted in the attached BID are fair and proper and are not tainted by collusion, conspiracy, connivance, or unlawful agreement on the part of the BIDDER or any other of its agents, representatives, owners, employees or parties in interest, including this affidavit.

By _____

Subscribed and sworn to before me this _____ day of _____, 20____ by _____ who
 is personally known to me or who has presented the following type of identification: _____.

SEAL

Notary Public (Signature), State of Florida

My Commission Expires: _____



DISCLOSURE OF POTENTIAL CONFLICT OF INTEREST AND CONFLICTING EMPLOYMENT OR CONTRACTUAL RELATIONSHIP

In accordance with Instructions to Bidder's, each BIDDER must disclose, in its submittal, the names of any employees who are employed by BIDDER who are also an employee of MCSB. Persons identified below may have obligations and restrictions applicable to them under Chapter 112, Florida Statutes.

Name of Bidder's Employee	MCSB Title or Position of Bidder's Employee	MCSB Department/ School of Bidder's Employee
_____	_____	_____
_____	_____	_____
_____	_____	_____
_____	_____	_____
_____	_____	_____

Check one of the following and sign:

- I hereby affirm that there are no known persons employed by BIDDER who are also an employee of MCSB.
- I hereby affirm that all known persons who are employed by BIDDER, who are also an employee of MCSB, have been identified above.

Signature

Company Name

Name, Title of Official

Business Address, City, State, Zip Code



DRUG FREE WORKPLACE CERTIFICATION

IDENTICAL TIE RFPS: Preference shall be given to businesses with drug-free workplace programs. Whenever two or more bids which are equal with respect to price, quantity, and service are received by the State or by any political subdivision for the procurement of commodities or contractual services, an ITB received from a business that certifies that it has implemented a drug-free workplace program shall be given preference in the award process. Established procedures for processing tie ITBs will be followed if none of the tied vendors have a drug-free workplace program (Florida Statutes Section 287.087). In order to have a drug-free workplace program, a business shall:

1. Publish a statement notifying employees that the unlawful manufacture, distribution, dispensing, possession, or use of a controlled substance is prohibited in the workplace and specifying the actions that will be taken against employees for violations of such prohibition.
2. Inform employees about the dangers of drug abuse in the workplace, the business's policy of maintaining a drug-free workplace, and available drug counseling, rehabilitation, and employee assistance programs, and the penalties that may be imposed upon employees for drug abuse violations.
3. Give each employee engaged in providing the commodities or contractual services that are under ITB a copy of the statement specified in subsection (1).
4. In the statement specified in subsection (1), notify the employees that, as a condition of working on the commodities or contractual services that are under ITB, the employee will abide by the terms of the statement and will notify the employer of any conviction of, or plea of guilty or nolo contendere to, any violation of Chapter 893 or of any controlled substance law of the United States or any state, for a violation occurring in the workplace no later than five (5) days after such conviction.
5. Impose a sanction on, or require the satisfactory participation in a drug abuse assistance or rehabilitation program if such is available in the employee's community, by any employee who is so convicted.
6. Make a good faith effort to continue to maintain a drug-free workplace through implementation of this section.

As the person authorized to sign the statement, I certify that this firm complies fully with the above requirements.

Signature

(Print or Type Name)



SWORN STATEMENT ON PUBLIC ENTITY CRIMES

THIS FORM MUST BE SIGNED IN THE PRESENCE OF A NOTARY PUBLIC OR OTHER OFFICER AUTHORIZED TO ADMINISTER OATHS.

1. I understand that a "public entity crime" as defined in Paragraph 287.133(1)(g), Florida Statutes, means a violation of any state or federal law by a person with respect to and directly related to the transaction of business with any public entity or with any agency or political subdivision of any other state or with the United States, including, but not limited to, any bid or contract for goods or services to be provided to any public entity or an agency or political subdivision of any other state or of the United States and involving antitrust, fraud, theft, bribery, collusion, racketeering, conspiracy, or material misrepresentation.
2. I understand that "convicted" or "conviction" as defined in Paragraph 287.133(1)(b), Florida Statutes, means a finding of guilt or a conviction of the public entity crime, with or without an adjudication of guilt, in any federal or state trial court of record relating to charges brought by indictment or information after July 1, 1989, as a result of a jury verdict, nonjury trial, or entry of a plea of guilty or nolo contendere.
3. I understand that an "affiliate" as defined in Paragraph 287.133(1)(a), Florida Statutes, means:
 - a. A predecessor or successor of a person convicted of a public entity crime; or
 - b. An entity under the control of any person who is active in the management of the entity and who has been convicted of a public entity crime. The term "affiliate" includes those officers, directors, executives, partners, shareholders, employees, members, and agents who are active in the management of an affiliate. The ownership by one person of shares constituting a controlling interest in another person, or a pooling of equipment or income among persons when not for fair market value under an arm's length agreement, shall be a prima facie case that one controls another person. A person who knowingly enters into a joint venture with a person who has been convicted of a public entity crime in Florida during the preceding 36 months shall be considered an affiliate.
4. I understand that a "person" as defined in Paragraph 287.133(1)(e), Florida Statutes means any natural person or entity organized under the laws of any state or of the United States with the legal power to enter into a binding contract and which bids or applies to bid on contracts for the provision of goods or services let by a public entity, or which otherwise transacts or applies to transact business with a public entity. The term "person" includes those officers, directors, executives, partners, shareholders, employees, members, and agents who are active in management of an entity.
5. Based on information and belief, the statement that I have marked below is true in relation to the entity submitting this sworn statement. (Indicate which statement applies.)

- Neither the entity submitting this sworn statement, nor any officers, directors, executives, partners, shareholders, employees, members or agents who are active in management of the entity, nor any affiliate of the entity have been charged with and convicted of a public entity crime subsequent to July 1, 1989.
- The entity submitting this sworn statement, or one or more of the officers, directors, executives, partners, shareholders, employees, members, or agents who are active in management of the entity, or an affiliate of the entity has been charged with and convicted of a public entity crime subsequent to July 1, 1989.
- The entity submitting this sworn statement, or one or more of the officers, directors, executives, partners, shareholders, employees, members, or agents who are active in management of the entity, or an affiliate of the entity has been charged with and convicted of a public entity crime subsequent to July 1, 1989. However, there has been a subsequent proceeding before a Hearing Officer of the State of Florida, Division of



Administrative Hearings and the Final Order entered by the Hearing Officer determined that it was not in the public interest to place the entity submitting this sworn statement on the convicted vendor list. (Attach a copy of the final order)

I UNDERSTAND THAT THE SUBMISSION OF THIS FORM TO THE CONTRACTING OFFICER FOR THE PUBLIC ENTITY IDENTIFIED IN PARAGRAPH 1 (ONE) ABOVE IS FOR THAT PUBLIC ENTITY ONLY AND, THAT THIS FORM IS VALID THROUGH DECEMBER 31 OF THE CALENDAR YEAR IN WHICH IT IS FILED. I ALSO UNDERSTAND THAT I AM REQUIRED TO INFORM THE PUBLIC ENTITY PRIOR TO ENTERING INTO A CONTRACT IN EXCESS OF THE THRESHOLD AMOUNT PROVIDED IN SECTION 287.017, FLORIDA STATUTES FOR CATEGORY TWO OF ANY CHANGE IN THE INFORMATION CONTAINED IN THIS FORM.

(Signature)

STATE OF FLORIDA
COUNTY OF _____

Sworn to and subscribed before me on this ____ day of _____, 20____ by _____ who is personally known to me or who has presented the following type of identification: _____.

Signature of Notary Public, State of Florida

Notary seal (stamped in black ink)
OR
Printed, typed or stamped name of Notary and Commission Number



STATEMENT OF NO BID

Please complete and return this form prior to ITB opening date.

ITB NAME: _____

ITB NO: _____

COMPANY NAME: _____

PHONE NO: _____

We have declined to submit on this solicitation for the following reasons:

Specifications too "restrictive", i.e., geared toward one brand or manufacturer (Please explain below)

Insufficient time to respond to solicitation

We do not offer this product/service or equivalent

Our project schedule would not permit us to perform

Unable to meet specifications, please explain _____

Unable to meet requirements, please explain _____

Specifications unclear, please explain _____

Other, please specify _____

REMARKS:

WE UNDERSTAND THAT IF THE "NO BID" LETTER IS NOT EXECUTED AND RETURNED; OUR NAME MAY BE DELETED FROM THE LIST OF QUALIFIED BIDDERS FOR THE MCSD FOR FUTURE PROJECTS.

Typed Name

Title

Signature

Date



SECTION VIII
SAMPLE AGREEMENT

SECTION VIII
SAMPLE AGREEMENT



ITB# 1013-0-2022/LD

**PURCHASE AND INSTALLATION OF
INTERACTIVE FLAT PANELS (IFP)**

Purchasing Department
2845 SE Dixie Hwy Stuart, FL., 34997-5037



SAMPLE
MARTIN COUNTY SCHOOL BOARD CONTRACT
FOR
ITB NO. 1013-0-2022/LD
PURCHASE AND INSTALLATION OF
INTERACTIVE FLAT PANELS (IFP)

This CONTRACT, hereinafter "Contract," awarded and entered into the 17th day of May, 2022, by Agenda Item # _____, and between _____, hereinafter referred to as "Contractor" and the Martin County School District (K12), 1939 SE Federal Highway, Stuart, Florida 34994, hereinafter referred to as "District", for and in consideration of the following terms, conditions and covenants.

I. PURPOSE OF CONTRACT

The District intends to enter into a contract with Contractor for the provision to purchase and install Interactive Flat Panels (IFP) and the payment for those services by the District as set forth herein. All work for this project, including but not limited to, all profit and overhead, incidentals, all labor, installation/deinstallation, supervision, testing, machinery, equipment, tools, materials, cleanup and other means necessary to complete the described work in accordance with the specifications, and contract documents.

Section 1. Scope of Service

The Contractor shall purchase and install Interactive Flat Panels (IFP) on an as needed basis, pursuant to this Contract as hereinafter provided. Contractor shall purchase and replace broken interactive flat panels (IFP), as well as near end of life aging equipment, including repairs to existing IFPs in accordance with the specifications identified in Section IX of the ITB.

1.1 Replacement: If interactive flat panels are defective and cannot be repaired, no longer working, or the life cycle of the panel has expired, the Contractor will be contacted to remove and replace the IFP.

As part of the de-installation process, the Contractor is responsible for the removal of any existing projectors, digitizer panels, interactive panels, associated mounts, poles, and cabling. Documentation of asset-tagged removed equipment must be provided to District in a format determined by District. Items to remove in a typical de-installation may include, but are not limited to, projector, projector mount, smartboard, mounts, mounting hardware, VCRs, and all associated wiring/cables.

1.2 Repairs: Equipment failure will result in the Contractor to provide a diagnosis and treatment for repairs to ensure equipment is operable to pass inspection. If repairs are not cost effective, Project Manager may approve direct replacement of panel.

All rates quoted shall include travel means, labor and all equipment and tools required. There shall be no charges to and from the work sites.

Contractor represents that the materials and equipment submitted are as described in the ITB. No substitutions of equipment will be accepted due to standardization.

The detailed scope of services to be performed and schedule of fees for those services as described in Exhibits A and B (District's original Invitation to Bid) and Exhibit B (Contractor's response to ITB #1013-0-2022/LD as accepted by the District) incorporated herein.

II. CONTRACT PROVISIONS

Section 2. Period of Service

2.1 Term of Contract

The initial term of this contract shall be for a one (1) year period effective from award through June 30, 2023 with the option of two (2) additional one-year renewal periods, upon the mutual written agreement of the parties. The District reserves the right to automatically extend any Contract for up to ninety (90) calendar days beyond the stated Contract term, under the same terms and conditions of said Contract. Additional extensions over the first ninety (90) day extension may not exceed six (6) months for the convenience of either party by mutual agreement to such extensions. The District shall notify the Contractor in writing of such extensions.

The performance period of this contract may be extended upon mutual agreement between the Contractor and the District with no change in terms or conditions. Any extension of performance period under this provision shall be in one-year increments. The contract may be renewed for two (2) additional one-year periods, provided both parties mutually are in agreement. Total contract length, including individual one-year extensions, shall not exceed three (3) years. Prior to each annual renewal, the District may consider price adjustment(s) only when a written request is received a minimum of (180) days prior to the renewal date for review and approval by the District. Consideration of price increases will be given provided such escalations are justified, reasonable and acceptable to the District. All price increases must be documented, and Board approved by the District. It is also expected that de-escalation of prices will be extended to the District if the market so reflects. The District reserves the right to not renew any contract regardless of price considerations.

The District reserves the right to automatically extend any Contract for up to ninety (90) calendar days beyond the stated Contract term, under the same terms and conditions of said Contract. Additional extensions over the first ninety (90) day extension may not exceed 6 months for the convenience of either party by mutual agreement to such extensions. The District shall notify the Contractor in writing of such extensions.

2.2 Business Operations

Regular Working Hours: Unless otherwise directed by the designated Director, the successful Contractor(s) shall insure that the following schedule is adhered to and services as required must be scheduled to insure that all work is during normal business hours, after student dismissal, between the hours of 1:50 PM - 3:00 PM. Department will convey the work schedule at time of order placement. Contractor's service representative shall respond back to all requests for repair by phone within sixty (60) minutes.

Observed Holidays: The District also schedules non-work days throughout the calendar year. The Facilities/Maintenance Directors or designee will notify the awarded Contractor of any non-work days that may affect the work schedule:

New Year's Day	Martin Luther King Day
President's Day	Spring Break
Memorial Day	Independence Day
Labor Day	Veteran's Day
Thanksgiving Day & Day After	Christmas Break

2.3 Completion of Services

All schedules and the necessary arrangements to implement the scope of work projects must be made with the review and approval of the Supervisor assigned.

Contractor must have the ability to complete (5) installations simultaneously within 72 hours from order request for new installs for break replace instances; Contractor must have the ability to complete (25) total installations per week.

Repair projects must be completed as quickly as reasonably possible and be completed within the timeframe provided on estimate.

2.4 Servicing Procedures

All work shall be tested to ensure panel is working properly. Contractor is to demonstrate this action prior to inspection by the District Official, based on installation and functionality checklist. All repairs and/or installations with any noted deficiencies or failed inspection must be corrected before invoice(s) for payment will be processed.

After diagnosis of work, technician will complete the work to ensure compliance with the terms of the bid prior to re-inspection. This work will be at no charge to the District.

All materials, preparation and workmanship shall conform to requirements in accordance with trade regulations.

All schedules must be established in advance and with prior approval. All schedules and the necessary arrangements to implement the scope of work must be mutually reviewed and approved by the Contractor and Project Manager or Designee. Under no circumstances shall any delivery, installation or training be attempted prior to approval of Project Manager or designee. All repair work to be performed, in the best workmanlike manner, as known to the trade.

On an as needed basis following failed inspection results, Contractor shall submit a written estimate of repairs necessary to achieve passing inspection results. This estimate shall include a total firm cost to the District itemized as follows; labor hours, equipment, itemization costs for material/parts, a brief description of the repair and/or replacement work to be done and location of work. Estimates must be complete and specific with measurements and quantities of time, completion, and materials. Project Manager or designee will provide Contractor with notice to proceed for commencement and approval of all work.

If new installation of IFP, Contractor shall submit a written itemized estimate with location, de-installation cost for the removal of the panel, cost of new panel, including labor, and materials necessary, and Project Manager's approval of installation.

Contractor to immediately notify Project Manager of any costs anticipated to exceed the original estimate submitted. At which time a change order may be implemented for necessary additional costs for completion of work. Re-inspection and testing of units shall be conducted immediately following repairs/replacements at no additional charge to District. (District may request copies of manufacturer's invoices from Contractor's suppliers as proof of material cost).

If the Contractor shall be delayed in the completion of work by reason of unforeseeable causes beyond its control and without fault or negligence, including, but not restricted to, acts of God or neglect of any other contractor, the period herein specified for the completion of delivery shall be extended by such time as shall be approved by the Project Manager or designee.

Failure to obtain written approval on a quotation may result in non-payment. Contractor agrees and understands that the **contract shall not be construed as an exclusive arrangement** and further agrees that the District may, at any time, secure similar or identical services at its sole option for repair work. All repair work to be performed in the best workmanlike manner as known to the trade. All measures shall be made to have equipment operational and ready for re-inspection.

Upon completion of services, the District reserves the right to request a Supervisor to review the work performed by their technician if deemed necessary. Supervisors review to be at no additional charge to the District and considered part of the contract award. The District's Project Manager reserves the right to request the Contractor to review and provide written acknowledgement/report that work performed has been completed. Contractor's review to be at no additional charge to the District and considered part of the contract award. Contractor shall document any areas of concern that are above and beyond on their report. The report shall be signed by an authorized agent of the firm and submitted to the Project Manager by email address provided to the Contractor.

Contractor must maintain complete and accurate records of all services provided pursuant to the terms of this agreement. All work-repair tickets, service calls, etc. shall be kept for auditing purposes and to be used as a work history for each of the units. Contractor shall establish a written quarterly quality control program to insure requirements of the contract are provided such as: record of response performance, total time from receipt of call to arrival at the job site, number of trips to the job site taken to complete each repair/installation, a detailed description of their diagnosis, prognosis, any materials/supplies required, and location of work.

2.5 Workmanship

All work shall be performed in a professional manner and shall conform to all applicable District, County, State and Federal Regulations and/or Codes. The Contractor agrees to use trained personnel with adequate experience and skills in testing, inspection and maintenance of Interactive Flat Panels in accordance with all codes and regulations.

Contractor will be responsible for their own measurements and must submit a firm price accordingly. There will be no adjustments, for increase or decrease of the dimensions requested; therefore, the "Total Offer" must be based on accurate measurements by awarded bidder on. Failure to do so will be at the bidder's risk. Contractor shall furnish all parts and tools necessary to perform complete maintenance/repair services as specified in a safe manner. Repairs shall include diagnosis, removal and replacement of defective components, as service requires.

Contractor will be required to establish a written quality control program to insure requirements of the contract are provided such as: record of response performance, total lapse time from receipt of call to arrival at the job site, number of trips to the job site taken to complete each repair/installation, the number of technicians required to complete each repair.

Section 3. Compensation and Method of Payment

3.1 Schedule of Bid Prices

District will compensate Contractor for these Services in accordance with Contractor's pricing schedule formalized in "Exhibit B" to this Contract.

3.2 Report

Contractor will be required to establish a written quality control program to insure requirements of the contract are provided such as: record of response performance, total elapsed time from receipt of call to arrival at the job site, number of trips to the job site taken to complete each repair/installation, the number of technicians required to complete each repair.

3.3 Unit Prices

Invoices submitted for new installs shall reflect/mirror estimate for deinstallation, installation cost per panel. There will be no additional charges for mileage and/or travel time.

3.4 Invoices

The District requires a firm price for each contract period. Invoices will be checked to confirm compliance with quoted pricing. Failure to hold prices firm through each contract term will be grounds for contract termination.

Each service call shall be invoiced separately for repairs. The invoice shall reflect the hourly labor rate for repairs, and number of hours on-site with a separate itemized listing of the materials, (if applicable) shall mirror work ticket. For invoices involving materials, copies of list/catalog price shall be submitted for verification. Failure to supply copies of invoices may result in contract cancellation.

The hourly rate per call, whether equipment is repaired/serviced at the site or the contractor's shop, shall remain fixed through the term of the contract. There will be no additional charges for mileage and/or travel time. The first hour of service call may only be charged once per work order, after the initial service call.

All rates quoted shall include travel means, labor and all equipment and tools required. All disposal charges should be included in the contractor's overhead.

3.5 Payment by means of the District Purchasing Card (Pcard)

Payment will be paid upon completion and acceptance of the work, net 30 days. Invoices will be checked to confirm compliance with reports. Payments may also be paid by the Visa Purchasing Card or Automated Clearing House (ACH) electronic network for financial transactions with authorization.

Section 4. Audit

The Contractor agrees that the District or any of its duly authorized representatives shall, until the expiration of three years after expenditure of funds under this Agreement, have access to and the right to examine any directly pertinent books, documents, papers, and records of the Contractor involving transactions related to this Agreement. The Contractor agrees that payment(s) made under this Agreement shall be subject to reduction for amounts charged thereto which are found on the basis of audit examination not to constitute allowable costs under this Agreement. The Contractor shall refund by check payable to the District the amount of such reduction of payments. All required records shall be maintained until an audit is completed and all questions arising therefrom are resolved, or three years after completion of the project and issuance of the final certificate, whichever is sooner.

Section 5. Employment Verification

Pursuant to section 448.095, Florida Statutes, Contractor shall register with and use the U.S. Department of Homeland Security's E-Verify system, <https://e-verify.uscis.gov/emp>, to verify the work authorization status of all employees hired on and after January 1, 2021.

Contractor must provide evidence of compliance with section 448.095, Florida Statutes. Evidence shall consist of an affidavit from the Contractor stating all employees hired on and after January 1, 2021 have had their work authorization status verified through the E-Verify system and a copy of their proof of registration in the E-Verify system.

Failure to comply with this provision is a material breach of the Agreement and shall result in the immediate termination of the Agreement without penalty to School Board. Contractor shall be liable for all costs incurred by School Board securing a replacement Agreement, including but not limited to, any increased costs for the same services, any costs due to delay, and rebidding costs, if applicable.

Section 6. Contractor Responsibilities

6.1 Independent Contractor

The **Contractor** is an independent **Contractor** and is not an employee or agent of the District. Nothing in this Agreement shall be interpreted to establish any relationship other than that of an independent **Contractor**, between the District and the **Contractor**, its employees, agents, subcontractor, or assigns, during or after the performance of this Contract.

6.2 Non-Exclusive Contract

Contractor agrees and understands that the contract shall not be construed as an exclusive arrangement and further agrees that the District may, at any time, secure similar or identical services at its sole option.

6.3 Contractor's Records

As a condition precedent to **Contractor** filing any claim against District, **Contractor** shall make available to District all of **Contractor's** books and records (directly or indirectly related to the claim of **Contractor's** business) requested by District. Refusal to do so shall constitute a material breach of this contract and cause for dismissal of any litigation.

6.4 Debris

Contractor shall be responsible for the prompt removal of all debris which results from the contracted service. Contractor shall be responsible to ensure frequent pick-up of all refuse, rubbish, scrap materials and debris that results from their operations so that work sites presents a neat and orderly appearance at all times. All rubbish, scrap, etc., shall be transported from the premises. NO rubbish shall be deposited on the work site. At completion of work, the Contractor shall remove all work materials, tools, equipment, machinery, and surplus materials from the work site and shall leave project in ready to use condition.

6.5 Measurements

Contractor will be responsible for their own measurements and must submit a firm price accordingly by work order request. There will be no adjustments, for increase or decrease of measurements required for the job. Therefore, the "Total Offer" must be based on accurate measurements by Contractor during inspection. Failure to do so will be at the Contractor's risk.

6.6 Inspection of Facilities

It is the Contractor's responsibility to become fully informed as to the nature and extent of the work required and its relation to any other work in the area, including possible interference from other site activities. Thereby, Contractor is responsible for confirming actual site conditions prior to starting work, and assures that the work order produced will be completed as specified. **Any oral explanation provided prior to the bid opening will not be binding.**

6.7 Identification

The Contractor, Subcontractors, and their employees are required to have visible, personal identification with the firm's company name displayed on their shirts. They will also be required to wear attire appropriate for a school environment: i.e., shirt, pants, & shoes. Clothing displaying nudity, obscene symbols, or pro-drug slogans is prohibited. The Contractor, Subcontractors, and all employees of same must check in and out at the main office before starting work during normal school hours. Before or after normal school hours, contact the on-site custodial staff.

6.8 Conduct

The Contractor acknowledges and understands that the job is being performed on public property owned by the MCSD, which may at various times during the completion of the job be occupied by students, teachers, parents, and school administrators. Accordingly, in order to secure the property, and otherwise comply with applicable law, the Contractor agrees to the following provisions, and also agrees that the failure to comply with any of these provisions may result in the termination of this Contract.

The Contractor shall immediately remove from the job site, for the duration of the job, any person making an inappropriate religious, racial, sexual or ethnic comment, statement or gesture toward any other individual.

The Contractor, Subcontractors, and their employees will refrain from using foul, abusive or profane language on school district property. Smoking/tobacco, firearms/weapons and illegal drugs are prohibited on school district property, including all buildings and grounds.

The Contractor shall enforce strict discipline and good order among their employees at all times. Contractor's personnel shall have absolutely no contact with students or staff, other than administrative personnel or designated representatives, with the exception of emergency situations.

No radios are allowed on the job site.

6.9 Badge Policy

This work is to take place on an active campus with active buildings around the area of work. All personnel working onsite with this project must have & wear MCSD badge at all times on the site. Contractor must apply for the MCSD Badge and pay for all associated costs for each individual working on the project.

6.10 Performance & Payment Bonds

Contractor is required to furnish payment and performance bonds and included in Exhibit D, with a carrier duly licensed and authorized to do business in the State of Florida equal to one hundred percent (100%) of the total amount of the contract to assure faithful performance and timely payments to all persons providing labor, materials or supplies used in the performance of the work.

Section 7. Termination

7.1 Termination for Convenience

The District, by written notice, shall have the right to terminate and cancel the Contract, without the Contractor being at fault, for any cause or for its own convenience, and require the Contractor to immediately stop work. In such event, the District shall pay the Contractor for the work actually performed. The District shall not be liable to the Contractor for any other costs, charges, or expenses, including but not limited to, prospective profits and overhead on work not performed.

7.2 Termination for Contractor's Failure to Perform

In addition to any other termination provisions that may be provided in the Contract, the District may terminate the Contract in whole or in part if the Contractor makes a false Invoice or fails to perform any obligation under the Contract and does not remedy the failure within ten (10) calendar days after receipt by the Contractor of written demand from the District to do so, unless, however, the nature of the failure is such that it cannot, in the exercise of reasonable diligence, be remedied within ten (10) calendar days, in which case the Contractor shall have such time as is reasonably necessary to remedy the failure. In the event that the Contractor abandons this Contract or causes it to be terminated, Contractor shall indemnify the District against loss pertaining to this termination.

7.3 Payment upon Termination

Upon termination of the Contract, the District shall pay the Contractor for those Services actually rendered and contracted for under the Contract, and those reasonable and provable expenses required and actually incurred by the Contractor for Services prior to the effective date of termination. Where the Contract is terminated for cause by the District, such payment shall be reduced by an amount equal to any reasonable and provable expenses actual incurred by the District as a direct result of the termination.

7.4 Default

In case of default by the Contractor, the Board may procure the articles or services from other sources and hold the Contractor responsible for any excess costs incurred thereby.

7.5 Performance Evaluation

Throughout the contract period the Contractor(s) performance will be monitored by District staff. If performance fails to meet the standards specified or noncompliance with the conditions, terms, specifications and requirements of the ITB and receives an unacceptable rating, the District may without cause and without prejudice to any other right or remedy, terminate the contract whenever the District determines that such termination is in the best interest of the District. Contractor's receiving an unacceptable rating shall be served by written notice by the Procurement Department. The District shall be the sole judge of nonperformance.

Section 8. Obligations

8.1 Representative or Delegate of the District with the authority to act on the District's behalf with respect to all aspects of the Project is:

8.2 The Key contact for services for the Contractor with authority to act on the Firm's behalf with respect to all aspects of the Project is:

8.3 Cooperation with District

District reserves the right to supervise all services, repairs and/or installation required under this contract and to provide the requisite parts from District stock. District also reserves the right to have District personnel assist and work together with Contractor's personnel when it is deemed in the best interest of District. This Special Condition will NOT void ANY warranty provisions or ITB Specifications stated in this document, including the one-year "on-site" warranty for parts and labor provided by the Contractor, while working in cooperation with District authorized personnel.

Section 9. Warranty

Should any defect in materials or workmanship, excepting ordinary wear and tear, appear during the stated warranty period, the Contractor shall repair or replace same at no cost to the District:

9.1 Installation

Contractor shall warranty all workmanship/labor for a period of 12 months from date of completion and final acceptance by the Maintenance Department designee. Should any defect in workmanship, excepting ordinary wear and tear, appear during the above stated warranty period, the successful bidder shall repair or replace same at no cost to the District, immediately upon written notice from the Maintenance Department Designee.

9.2 Parts

Contractor shall provide full factory warranty on all new parts. The factory warranty shall become effective on the date of installation.

9.3 IFP/Hardware

Hardware is defined as the panel, stand/mount, stand accessories and height adjustment mechanism, including online and phone support for a minimum of seven (7) years.

9.4 Software

Warranty should consist of free upgrades for a minimum of ten (10) years.

Section 10. Protection of Property

The Contractor shall at all times guard against damage or loss to the property of the District or that of other vendors or contractors and shall be held responsible for replacing or repairing any such loss or damage. The District may withhold payment or make such deductions, as deemed necessary, to ensure reimbursement or replacement for loss or damage to property through negligence of the Contractor or their agents.

The Contractor shall be responsible for the protection of property in the areas in the adjacent vicinity of the project; and for the protection of his own equipment, supplies, materials and work, against any damage resulting from the elements (such as flooding, rainstorms, wind damage, or other acts of God) or vandalism.

Section 11. Equipment / Materials / Parts

All equipment / materials must be new, of current manufacturer. All equipment supplied shall contain complete maintenance instructions, operating manuals and parts lists. All parts required shall be genuine parts as manufactured and distributed by the manufacturer. Only original equipment manufacturer (OEM) parts may be utilized, unless authorized by proper District personnel.

The District reserves the right to obtain parts as a direct pass-thru from other sources or may exercise the option to directly purchase equipment at District's cost. The parts provided under this contract must be verified by the submission of an itemized list of materials proposed for purchase from the identified source, each unit priced by cost, the total price and the cost-plus mark-up. Any remaining materials, after project completion, become the property of District. It will be the District's responsibility to inspect and accept parts purchased by District. Contractor will only provide the services required to complete the work with the District purchased materials.

Section 12. Persons Bound by Contract

12.1 Parties to the Contract

The persons bound by this Contract are the Contractor and the District and their respective partners, successors, heirs, executors, administrators, assigns and another legal representative.

12.2 Assignment of Interest in Contract

This Contract and any interest or services associated with this Contract may not be assigned, sublet or transferred to another by either party without the prior written consent of the other party. Nothing contained herein shall be construed to prevent Contractor from employing such independent Contractors, associates and Sub-Contractors as Contractor may deem appropriate to assist in the performance of the services hereunder.

12.3 Rights and Benefits

Nothing herein shall be construed to give any rights or benefits arising from this Contract to anyone other than Contractor and the District.

Section 13. Indemnification of District

Contractor agrees to protect, defend, indemnify, and hold harmless the District, its employees, representatives, and elected officials from any and all claims and liabilities including all attorney's fees and court costs, including appeals, for which the District, its employees, representatives, and elected officials can or may be held liable as a result of injury (including death) to persons or damage to property occurring by reason of any negligence, recklessness, or intentional wrongful misconduct of the Contractor, its employees, or agents, arising out of or connected with this Agreement. Contractor shall not be required to indemnify the District or its agents, employees, representatives, or elected officials when an occurrence results solely from the wrongful acts or omissions of the District, or its agents, employees or representatives.

Contractor, without exemption, shall indemnify and hold harmless, the District, its employees, representatives and elected officials from liability of any nature or kind, including cost and expenses for or on account of any copyrighted, service marked, trademarked patented or unpatented invention, process, or any other intellectual property right or item manufactured by the Contractor. Further, if such a claim is made, or is pending, the Contractor may, at its option and expense, procure for the District the right to use, replace, or modify the item to render it non-infringing. If none of the alternatives are reasonably available, the District agrees to return the article on request to the Contractor and receive reimbursement from the Contractor. If Contractor used any design,

device or materials covered by letters, patent or copyright, it is mutually agreed and understood, without exception, that the ITB prices shall include all royalties or cost arising from the use of such design, device or materials in any way involved in the work. This article will survive the termination of any contract with the School District.

The parties agree that Ten Dollars (\$10.00) of the total compensation paid to the Contractor for performance of this Agreement shall represent the specific consideration for the Contractor's indemnification of the Owner.

The District reserves the right to select its own legal counsel to conduct any defense in any such proceeding and all costs and fees associated therewith shall be the responsibility of Contractor under the indemnification agreement.

It is the specific intent of the parties hereto that the foregoing indemnification complies with F.S. 725.06 (Chapter 725). It is further the specific intent and agreement of the parties that all of the Contract Documents on this Project are hereby amended to include the foregoing indemnification and the "Specific Consideration" therefore.

Section 14. Insurance.

14.1 Requirements

Contractor shall procure and maintain insurance, in the amounts noted in in Section IV of the Invitation to Bid and included in "**Exhibit C**" of this Contract, which names the Contractor, its officers, board members, employees and agents as additional insured on General Liability and Automobile Liability insurance policies. Such certificate must contain a provision for notification of the District 30 days in advance of any material change or cancellation. The District by and through its Risk Manager, reserves the right to review, modify, reject or accept any required policies of insurance, including limits coverages or endorsements, herein from time to time throughout the term of this contract. All insurance carriers must have an A.M. Best Rating of at least A: VIII or better. When a self-insured retention or deductible exceeds \$5,000, the District reserves the right, but not the obligation, to review and request a copy of Contractor's most recent annual report or audited financial statement. All Contractors, including any independent Contractors and Sub-Contractors utilized, must comply with the insurance requirements as set forth in the documents identified and listed in "**Exhibit C**" attached hereto.

14.2 Certificate of Insurance

Certificates of all insurance required from the Contractor shall be attached to this agreement and shall be subject to the District's approval for adequacy.

Section 15. Professional Standards

All work shall be performed in a professional manner and shall conform to all applicable District, County, State and Federal Regulations and/or Codes. The Contractor shall also be responsible for obtaining all permits and licenses required to begin work, including the following:

Furnish all parts and tools necessary to perform complete maintenance/repair services as specified in a safe manner. The Contractor shall perform repairs requiring an electrician, unless predetermined that the District will perform the plumbing work. Repairs shall include diagnosis, removal and replacement of defective components, as service requires.

Manufactured items, fabricated assemblies and on-site contractor services shall comply with all applicable federal, state and local requirements. For on-site contractor services, the District reserves the right to request documentation of contractor compliance with OSHA standards to include but not be limited to: required employee safety & health training, written safety and health programs, provision of required personal protective equipment (PPE), and/or provision and use of required atmospheric monitoring equipment. Hazardous chemicals must be accompanied by a Material Safety Data Sheet (MSDS), as required by the Occupational Safety and Health Act (OSHA) of 1970; as amended, and any other applicable federal, state and local regulations.

Equipment must meet all State and Federal safety regulations for grounding of electrical equipment. The Martin County School District, Florida intends to purchase plumbing materials and services delivered and installed in accordance with the Uniform Plumbing Code, NFPA, National Fire Protection Association codes and standards, local and state regulations, and as requested by the Maintenance Services Department or Facilities Services Department.

Section 16. Non-Appropriation

This Contract is deemed effective only to the extent of the annual appropriations available.

Section 18. Public Records

If the Contractor has questions regarding the application of chapter 119, Florida statutes, to the Contractor's duty to provide public records relating to this contract, contact the custodian of public records, at 772.219.1200, ext. 30201, 1939 SE Federal Highway, Stuart, Florida 34994 or click [here](#) as per F.S. 119.12.

Public Records Relating to Compliance, Request for Records; Noncompliance, & Civil Action with F.S. 119.0701 the Contractor shall:

Keep and maintain public records required by the public agency to perform the service.

Upon request from the public agency's custodian of public records, provide the public agency with a copy of the requested records or allow the records to be inspected or copied within a reasonable time at a cost that does not exceed the cost provided in this chapter or as otherwise provided by law.

Ensure that public records that are exempt or confidential and exempt from public records disclosure requirements are not disclosed except as authorized by law for the duration of the contract term and following completion of the contract if the Contractor does not transfer the records to the public agency.

Upon completion of the contract, transfer, at no cost, to the public agency all public records in possession of the Contractor or keep and maintain public records required by the public agency to perform the service. If the Contractor transfers all public records to the public agency upon completion of the contract, the Contractor shall destroy any duplicate public records that are exempt or confidential and exempt from public records disclosure requirements. If the Contractor keeps and maintains public records upon completion of the contract, the Contractor shall meet all applicable requirements for retaining public records. All records stored electronically must be provided to the public agency, upon request from the public agency's custodian of public records, in a format that is compatible with the information technology systems of the public agency.

A request to inspect or copy public records relating to a public agency's contract for services must be made directly to the public agency. If the public agency does not possess the requested records, the public agency shall immediately notify the Contractor of the request, and the Contractor must provide the records to the public agency or allow the records to be inspected or copied within a reasonable time.

If a Contractor does not comply with the public agency's request for records, the public agency shall enforce the contract provisions in accordance with the contract.

A Contractor who fails to provide the public records to the public agency within a reasonable time may be subject to penalties under F.S. [119.10](#).

If a civil action is filed against a Contractor to compel production of public records relating to a public agency's contract for services, the court shall assess and award against the Contractor the reasonable costs of enforcement, including reasonable attorney fees, if:

1. The court determines that the Contractor unlawfully refused to comply with the public records request within a reasonable time; and
2. At least eight (8) business days before filing the action, the plaintiff provided written notice of the public records request, including a statement that the Contractor has not complied with the request, to the public agency and to the Contractor.

A notice complies with subparagraph 2 above, if it is sent to the public agency's custodian of public records and to the Contractor at the Contractor's address listed on its contract with the public agency or to the Contractor's registered agent. Such notices must be sent by common carrier delivery service or by registered, Global Express Guaranteed, or certified mail, with postage or shipping paid by the sender and with evidence of delivery, which may be in an electronic format.

A Contractor who complies with a public records request within eight (8) business days after the notice is sent is not liable for the reasonable costs of enforcement.

Section 19. Scrutinized Companies List

Pursuant to Sections 287.135, 215.4725, and 215.473, of the Florida Statutes which prohibits agencies from contracting with any company, principals, or owners on the Scrutinized Companies with Activities in Sudan List, participation in the Boycott of Israel, the Scrutinized Companies with Activities in the Iran Petroleum Energy List, and is not engaged in business operations in Cuba or Syria are prohibited from contracting for goods or services in any amount at the time of submitting to this RFP through the term of this contract, including renewals or extensions.

By signature of this agreement, Contractor certifies and attests that firm is not on any list, engaged in any business operations, or participates in activities as specified in this section. If firm is found negligent, contract shall be terminated; and submission of a false certification may subject firm to civil penalties, attorney's fees, and/or costs.

Section 20. Exhibits

The following Exhibits are attached to and made a part of this Contract:

"Exhibit A" - "Original Invitation to Bid as Issued by District, including all Addenda"

"Exhibit B" - "Bid as Submitted by Contractor and Accepted by District"

"Exhibit C" - "Insurance and Indemnification"

"Exhibit D" - "Performance & Payment Bonds"

[REMAINDER OF PAGE INTENTIONALLY LEFT BLANK]

Signatures are on following page

IN WITNESS WHEREOF, the parties hereto have accepted, made and executed this Agreement in counterparts each of which shall be treated as an original upon the terms and conditions above stated.

CONTRACTOR

Attest

Witnesses

NAME, TITLE

As to the DISTRICT on the ____ day of _____, _____.

MARTIN COUNTY SCHOOL DISTRICT

Attest

Witness

Marsha Powers, Board Chair

ALL DOCUMENTS EXHIBITS SHALL BE ATTACHED HERE

SAMPLE



**SECTION IX
EXHIBITS / SPECIFICATIONS**

BOXLIGHT PROCOLOR 753U

BOXLIGHT PROCOLOR 863U

**SECTION 26 05 03
EQUIPMENT WIRING SYSTEMS**

**SECTION 26 05 19
BUILDING WIRE AND CABLE**

**SECTION 27 41 00
AUDIO-VISUAL EQUIPMENT**

ProColor 753U

Students will see everything with Boxlight's vibrant 75" ProColor interactive LCD flat panel Android display. Touch technology and collaboration come alive in brilliant 4K ultra-high definition.



Features

- Up to 20 single-point users or 10 dual-touch and gestures users with Touch 360° interactivity, driving collaborative learning to a new level*
- Built-in high-power Android 8+ OS for touch control and wide selection of apps
- Access to MimioMarket app store
- 4K video resolution (3,840 x 2,160)
- LED backlighting for energy efficiency
- Includes several classroom software options with a collaboration app

Optional

- Internal Windows 10 compatible PC (available with Intel i5 or i7)
Windows 10 license not included

*Multi-touch is available on Windows systems, MacOS uses multi-touch gestures but can allow for multi-touch when used with software that has multitouch capabilities IE: MimioStudio. Linux and Chrome are single touch.

Specifications

Dimensions and Weight	
Overall Dimensions (W x H x D)	1,710 mm x 1,020 mm x 86 mm (67.3 in. x 40.2 in. x 3.4 in.)
Net Weight	51.8 kg (114.2 lb)
Packaged Dimensions (W x H x D)	1,860 mm x 1,170 mm x 280 mm (73.2 in. x 46.1 in. x 11.0 in.)
Gross Weight	70.4 kg (155.2 lb)
Effective Screen Size (W x H)	1,650 mm x 928 mm (65.0 in. x 36.5 in.)
Active Screen Size (Diagonal)	75 in.
Image	
Screen Type	LCD (IPS type)
Display Format Native Resolution	3,840 x 2,160
Aspect Ratio	16:9
Picture Response Time (Gray to Gray)	8 ms
Refresh Frequency	60 Hz
Pixel Pitch	0.43 x 0.43 mm
Panel Resolution	3,840 x 2,160
Display Colors	1.07 B (10-bit)
Brightness (Typical)	350 cd/m ²
Contrast Ratio	1,200:1
Viewing Angle	Hor. 178°, Ver. 178°
Backlight Life	Direct light-emitting diode (LED) illumination rated at 50,000 hours

Touch Tracking	
Tracking Technology	Touch 360° infrared
Touch Points Operating Systems	20-touch: Windows 7+ and MacOS (only in supported software) Single touch: Linux, Chrome
Touch Tool	Stylus, finger (even if gloved), or solid object
Two-Pen-Two-Color	Supported, application dependent
Tracking Accuracy	± 1.5 mm
Writing Height	< 3 mm
Minimum Object Size	3 mm
Tracking Read Speed	>125 frames/s
Tracking Response	≤10 ms
Tracking Points	32,767 x 32,767
Driver Required	No
Safety	
Anti-Glare Glass	Yes
Protective Glass	4 mm tempered glass Level 7 Mohs
Connections	
Input/Output	Input: <ul style="list-style-type: none"> - HDMI 2.0 x 3 - VGA x 1 - PC analog audio 3.5 mm x 1 Output: <ul style="list-style-type: none"> - HDMI x 1 (4K2K) - Analog 3.5 mm x 1 - SPDIF digital audio output coax x 1 USB: <ul style="list-style-type: none"> - USB 2.0 for Android x 2 in front - USB 2.0 for software updates only, 1 on side) - USB 3.0 x 3 (2 side, 1 front) - USB 2.0 Type-B for touch control x 2

	Data and Control: - RS-232 x 1 - LAN RJ-45 (10/100/1000Mbps) x 1
Control	
Network Controllable	Boxlight NDMS compatible
Audio	
Output	12 W x 2 into internal 8 Ohm speakers
Sound System	Stereo
Equalizer	Yes
Sound Status Memory	Yes
Balance	Yes
Environmental	
Storage Temperature	-20° to 60° C (-4° to 140° F)
Storage Humidity	10% to 90%
Operating Temperature	0° to 40° C (32° to 104° F)
Operating Humidity	10% to 90%
Power Requirement	100–240 VAC 60/50 Hz
Power Consumption	350 W operating, <0.5 W sleep mode
Mount	
Mounting Screw Size	M8 x 25 mm
VESA Form Factor	800x400 mm
Accessories	
HDMI Cable	1 x 3 m

AC Power Cable	1 x 3 m
USB Cable	1 x 5 m
Passive Stylus	2 x magnetic
Remote Control	1 (with batteries)
Android	
Version	Android 8.0 Oreo
CPU	Dual core A73+, Dual Core A53
GPU	Quad Core Mali G51
RAM	4 GB
ROM	32 GB
App Store	Yes, MimioMarket

What's in the box:

Hardware

- Magnetic Stylus x 2
- Remote Control with Batteries
- Wi-Fi Module
- ProColor Wallmount-003

Documentation

- Warranty Card
- QuickStart Guide

Cables

- HDMI cable (3 m)
- USB A-to-B for touch (5 m)
- US power cord (3 m)



Software Options

- MimioConnect - 3 Year License
- MimioStudio Software - Perpetual License
- MimioMobile Collaboration App - 3 Year License
- OKTOPUS - Perpetual License
- OKTOPUS Blend, Collaboration App & Premium Lessons - 3 Year License

Display Apps

- MimioMarket - App Store
- MimioMessage - Announcement App (Coming Soon)
- Unplug'd - Screen Casting
- Basic Network Device Management

Online Professional Development Courses : [Learn More](#)

- ProColor3 Interactive Flat Panel
- OKTOPUS Basics
- OKTOPUS GamesZones
- OKTOPUS Blend
- MimioStudio Basics
- MimioConnect

Drawings

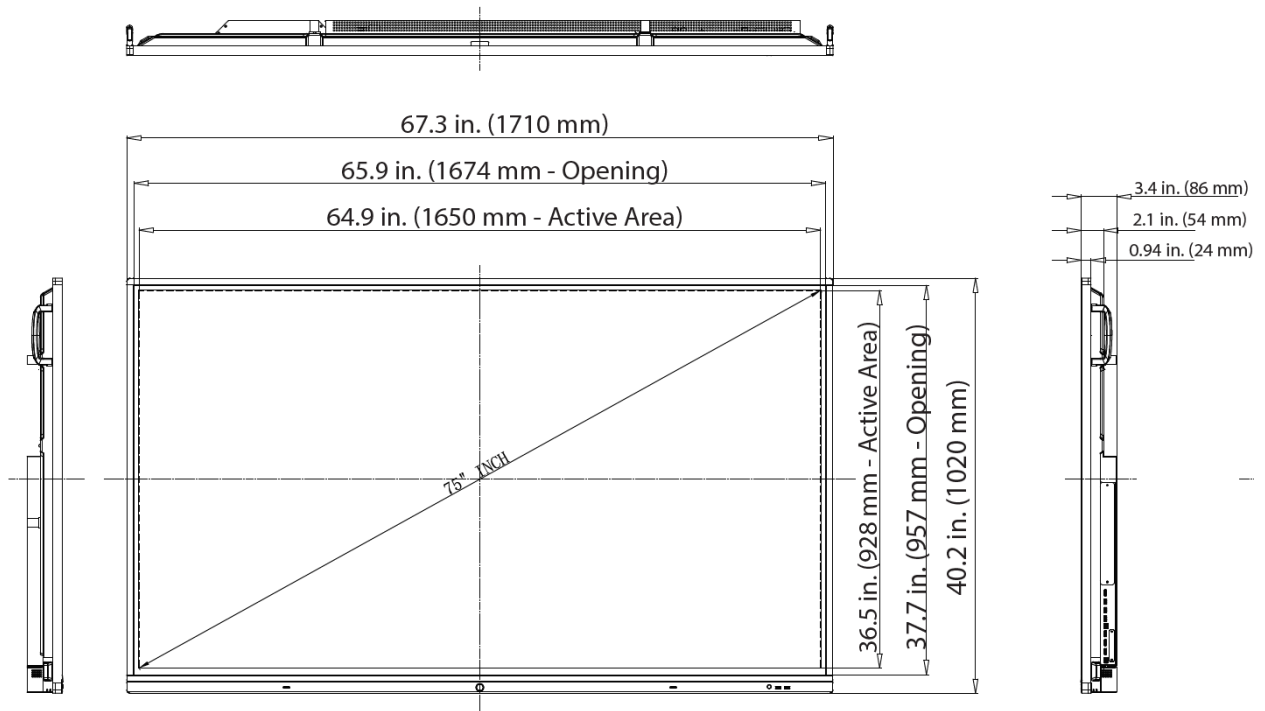

Connections

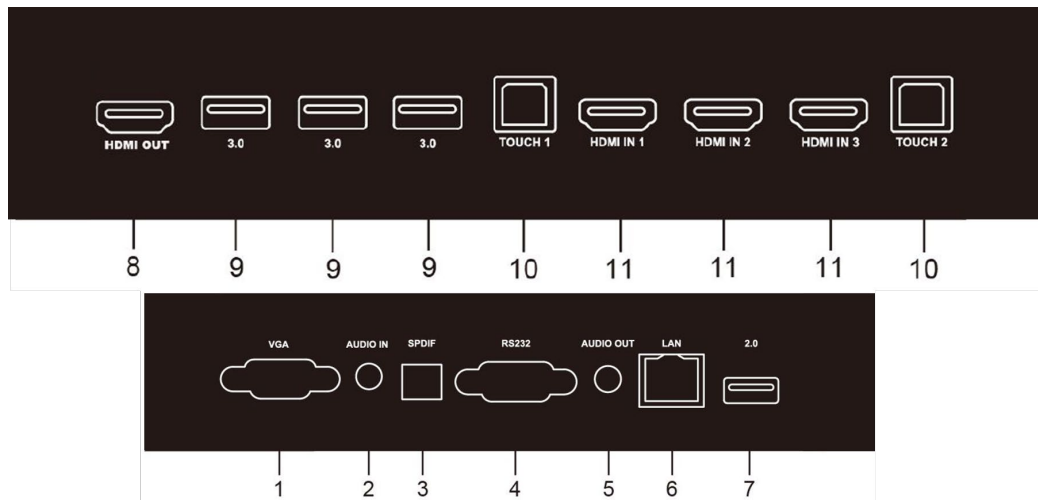

Number	Items	Function description
1	VGA	External computer image input
2	AUDIO IN	External computer audio input
3	SPDIF	Carry multichannel sound via optical signals.
4	RS232	Serial interface, used for mutual transfer of data between devices
5	AUDIO OUT	Audio output to the external speaker
6	LAN	Connect RJ45 terminals
7	2.0	USB 2.0, connect USB devices such as mobile hard disk, U disk, USB keyboard and mouse, USB drives, etc.
8	HDMI OUT	Connect to the devices with HDMI input function
9	3.0	USB 3.0, connect USB devices such as mobile hard disk, U disk, USB keyboard and mouse, USB drives, etc.
10	TOUCH	Touch signal output to the external computer
11	HDMI IN	High-definition multimedia interface signal input, connect to devices with HDMI output interface (personal computer with HDMI output, set-top box, or another video device)
12	AC IN	AC power input, connect AC power supply
13	AC SWITCH	To open or shut down AC power supply. "I" means power on, "O" means power off

Please note: ProColor Series 3 flat panels can only be used horizontally in a table top for 90 minutes before needing to be returned to a vertical position. They must remain in a vertical position for a minimum of 30 minutes before they can put into a tilted configuration again.

Specifications are subject to change without notice.

ProColor 863U

Students will see everything with Boxlight's vibrant 86" ProColor interactive LCD flat panel Android display. Touch technology and collaboration are brought to life in brilliant 4K ultra-high definition.



Features

- Up to 20 single-point users or 10 dual-touch and gestures users with Touch 360° interactivity, driving collaborative learning to a new level*
- Built-in high-power Android 8+ OS for touch control and wide selection of apps
- Access to the MimioMarket App Store
- 4K video resolution (3,840 x 2,160)
- LED backlighting for energy efficiency
- Includes several classroom software options with a collaboration app

Options

- Internal Windows 10 compatible PC (available with Intel i5 or i7)
Windows 10 license not included

*Multi-touch is available on Windows systems, MacOS uses multi-touch gestures but can allow for multi-touch when used with software that has multitouch capabilities IE: MimioStudio. Linux and Chrome are single touch.

Specifications

Dimensions and Weight	
Overall Dimensions (W x H x D)	1,957.2 mm x 1,160 mm x 86 mm (77.1 in. x 45.7 in. x 3.4 in.)
Net Weight	64.65 kg (142.6 lb)
Packaged Dimensions (W x H x D)	2,211 mm x 1,370 mm x 280 mm (87.1 in. x 53.9 in. x 11.0 in.)
Gross Weight	95.6 kg (210.8 lb)
Effective Screen Size (W x H)	1,895 mm x 1,065 mm (74.6 in. x 41.9 in.)
Active Screen Size (Diagonal)	86 in.
Image	
Display Format Native Resolution	3,840 x 2,160
Aspect Ratio	16:9
Picture Response Time (Gray to Gray)	8 ms
Refresh Frequency	60 Hz
Pixel Pitch	0.49 mm x 0.49 mm
Panel Resolution	3,840 x 2,160
Display Colors	1.07 B (10-bit)
Brightness (Typical)	350 nits
Contrast Ratio	1,200:1
Viewing Angle	Hor. 178°, Ver. 178°
Backlight Life	Direct light-emitting diode (LED) illumination rated at 50,000 hours

Touch Tracking	
Tracking Technology	Touch 360° infrared
Touch Points Operating Systems	20-touch: Windows 7+ and MacOS (only in supported software) Single touch: Linux, Chrome
Touch Tool	Stylus, finger (even if gloved), or solid object
Two-Pen-Two-Color	Supported, application dependent
Tracking Accuracy	± 1.5 mm
Writing Height	≤ 3 mm
Minimum Object Size	3 mm
Tracking Read Speed	>125 frames/s
Tracking Response	≤10 ms
Tracking Points	32,767 x 32,767
Driver Required	No
Safety	
Anti-Glare Glass	Yes
Protective Glass	4 mm tempered glass Level 7 Mohs
Connections	
Input/Output	Input: - HDMI 2.0 x 3 - VGA x 1 - PC analog audio 3.5 mm x 1 Output: - HDMI x 1 (4K2K) - Analog 3.5 mm x 1 - SPDIF digital audio output coax x 1 USB: - USB 2.0 for Android x 2 in front - USB 2.0 for software updates only, 1 on side) - USB 3.0 x 3 (2 side, 1 front) - USB 2.0 Type-B for touch control x 2

	Data and Control: - RS-232 x 1 - LAN RJ-45 (10/100/1000Mbps) x 1
Control	
Network Controllable	Boxlight NDMS compatible
Audio	
Output	12 W x 2 into internal 8 Ohm speakers
Sound System	Stereo
Equalizer	Yes
Sound Status Memory	Yes
Balance	Yes
Environmental	
Storage Temperature	-20° to 60° C (-4° to 140° F)
Storage Humidity	10% to 90%
Operating Temperature	0° to 40° C (32° to 104° F)
Operating Humidity	10% to 90%
Power Requirement	100–240 VAC 60/50 Hz
Power Consumption	550 W operating, < 0.5 W sleep mode
Mount	
Mounting Screw Size	M8 x 25 mm
VESA Form Factor	800 x 600 mm
Accessories	
HDMI Cable	1 x 5 m

AC Power Cable	1 x 3 m
USB Cable	1 x 5 m
Passive Stylus	2 x magnetic
Remote Control	1 (with batteries)
Android	
Version	Android 8.0 Oreo
CPU	Dual core A73+, Dual Core A53
GPU	Quad Core Mali G51
RAM	4 GB
ROM	32 GB
App Store	Yes, MimioMarket App Store

What's in the box:

Hardware

- Magnetic Stylus x 2
- Remote Control with Batteries
- Wi-Fi Module
- ProColor Wallmount-003

Documentation

- Warranty Card
- QuickStart Guide

Cables

- HDMI cable (3 m)
- USB A-to-B for touch (5 m)
- US power cord (3 m)



Software Options

- MimioConnect - 3 Year License
- MimioStudio Software - Perpetual License
- MimioMobile Collaboration App - 3 Year License
- OKTOPUS - Perpetual License
- OKTOPUS Blend, Collaboration App & Premium Lessons - 3 Year License

Display Apps

- MimioMarket - App Store
- MimioMessage - Announcement App (Coming Soon)
- Unplug'd - Screen Casting
- Basic Network Device Management

Online Professional Development Courses : [Learn More](#)

- ProColor3 Interactive Flat Panel
- OKTOPUS Basics
- OKTOPUS GamesZones
- OKTOPUS Blend
- MimioStudio Basics
- MimioConnect

Drawings

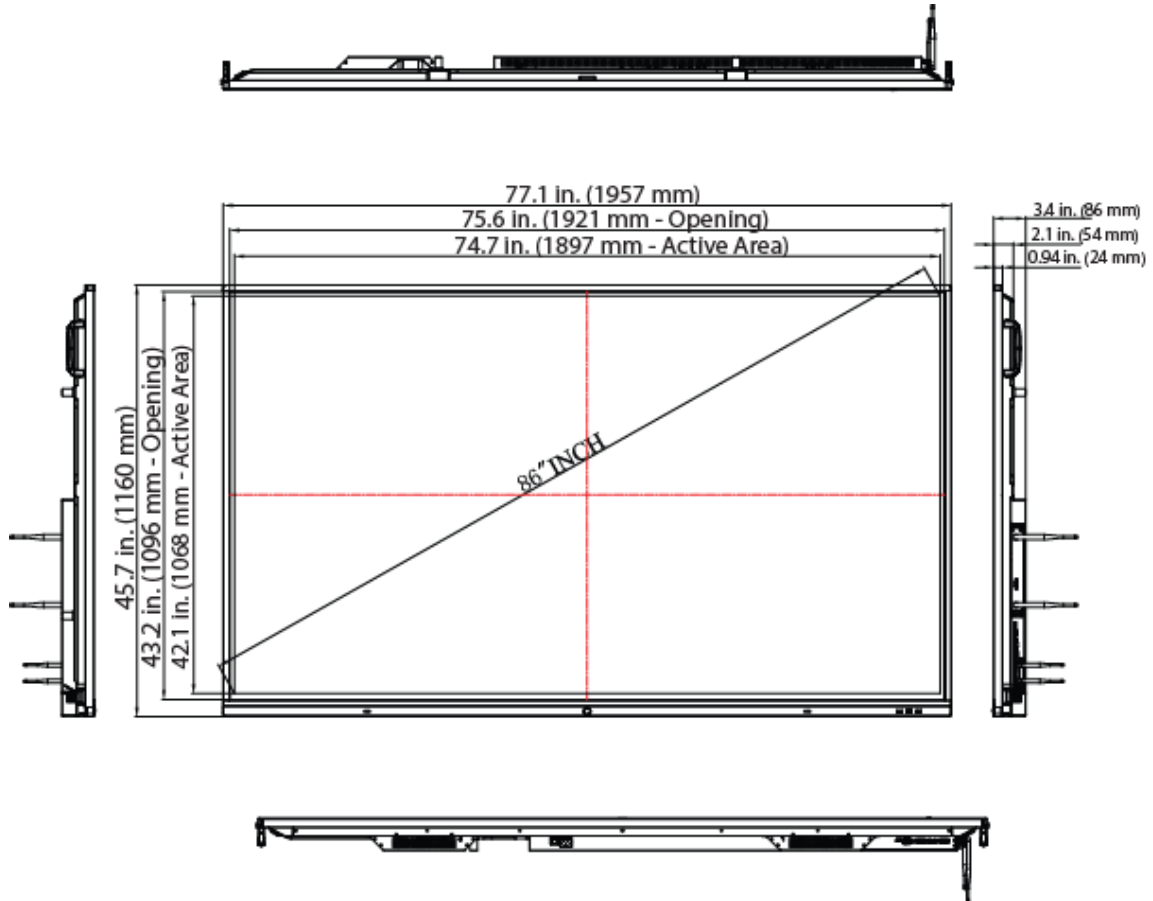

Connections

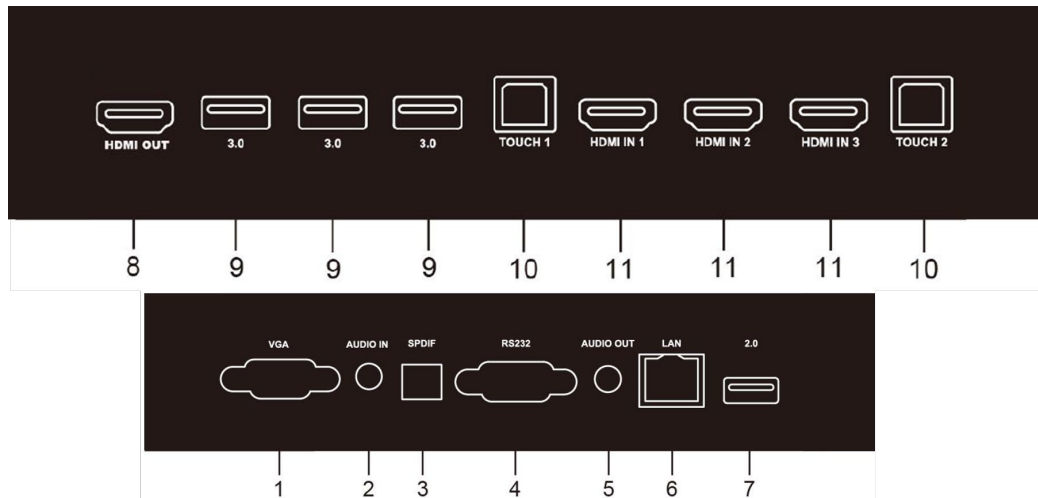

Number	Items	Function description
1	VGA	External computer image input
2	AUDIO IN	External computer audio input
3	SPDIF	Carry multichannel sound via optical signals.
4	RS232	Serial interface, used for mutual transfer of data between devices
5	AUDIO OUT	Audio output to the external speaker
6	LAN	Connect RJ45 terminals
7	2.0	USB 2.0, connect USB devices such as mobile hard disk, U disk, USB keyboard and mouse, USB drives, etc.
8	HDMI OUT	Connect to the devices with HDMI input function
9	3.0	USB 3.0, connect USB devices such as mobile hard disk, U disk, USB keyboard and mouse, USB drives, etc.
10	TOUCH	Touch signal output to the external computer
11	HDMI IN	High-definition multimedia interface signal input, connect to devices with HDMI output interface (personal computer with HDMI output, set-top box, or another video device)
12	AC IN	AC power input, connect AC power supply
13	AC SWITCH	To open or shut down AC power supply. "I" means power on, "O" means power off

Please note: ProColor Series 3 flat panels can only be used horizontally in a table top for 90 minutes before needing to be returned to a vertical position. They must remain in a vertical position for a minimum of 30 minutes before they can put into a tilted configuration again.

Specifications are subject to change without notice.

SECTION 26 05 03
EQUIPMENT WIRING SYSTEMS

PART 1 – GENERAL

1.1 DESCRIPTION OF SYSTEM

- A. Provide and install all equipment, labor, material, accessories, and mounting hardware for a complete and operating system for the following:
 - 1. Electrical connections to equipment specified under other sections.

1.2 RELATED SECTIONS

- A. Summary of Work
- B. Conduit.
- C. Building Wire and Cable.
- D. Boxes.
- E. Electric Doors

1.3 REFERENCES

- A. NEMA WD 1 - General Requirements for Wiring Devices
- B. NEMA WD 6 - Wiring Devices-Dimensional Requirements
- C. ANSI/NFPA 70 - National Electrical Code.

1.4 SUBMITTALS

- A. Submit under provisions of the General Requirements of the Contract Documents and Section Submittals.

1.5 REGULATORY REQUIREMENTS

- A. Conform to requirements of ANSI/NFPA 70.
- B. Furnish products listed and classified by Underwriters Laboratories, Inc. as suitable for purpose specified and shown.

1.6 COORDINATION

- A. Obtain and review shop drawings, product data, and manufacturer's instructions for equipment furnished under other sections.
- B. Determine connection locations and requirements.
- C. Sequence rough-in of electrical connections to coordinate with installation schedule for equipment.
- D. Sequence electrical connections to coordinate with start-up schedule for equipment.

PART 2 – PRODUCTS

2.1 CORDS AND CAPS

- A. Attachment Plug Construction: Conform to NEMA WD 1.
- B. Configuration: NEMA WD 6; match receptacle configuration at outlet provided for equipment.
- C. Cord Construction: ANSI/NFPA 70, Type SO multi-conductor flexible cord with identified equipment grounding conductor, suitable for use in damp locations.
- D. Size: Suitable for connected load of equipment, length of cord, and rating of branch circuit overcurrent protection.

PART 3 – EXECUTION

3.1 EXAMINATION

- A. Verify conditions under provisions of Section Investigation of Existing Electrical Systems.
- B. Verify that equipment is ready for electrical connection, wiring, and energization.

3.2 ELECTRICAL CONNECTIONS

- A. Make electrical connections in accordance with equipment manufacturer's instructions.
- B. Make conduit connections to equipment using flexible conduit. Use liquidtight flexible conduit with watertight connectors in damp or wet locations (including inside of coolers/freezers).
- C. Make wiring connections using wire and cable with insulation suitable for temperatures encountered in heat producing equipment and in cooler/freezers.
- D. Provide receptacle outlet where connection with attachment plug is required. Provide cord and cap where field-supplied attachment plug is required.
- E. Provide suitable strain-relief clamps and fittings for cord connections at outlet boxes and equipment connection boxes.
- F. Install disconnect switches, controllers, control stations, and control devices as required.
- G. Modify equipment control wiring with terminal block jumpers as required.
- H. Provide interconnecting conduit and wiring between devices and equipment where required.
- I. Coolers and Freezers: Cut and seal conduit openings in freezer and cooler walls, floor, and ceilings.

3.3 EQUIPMENT CONNECTION SCHEDULE

- A. By local authority and as required for a complete and operating service.
- B. Electric Door(s):
 - 1. Electrical Connection: liquid tight flexible conduit with local field installed disconnect switch and field installed control switch.
 - 2. Voltage: 120 volts, 1 phase, 60 Hz.
 - 3. Load rating: 1/2 hp.
- C. CCTV Equipment:
 - 1. Electrical Connection: Wiremold plug strips as required with surge suppression.
 - 2. Voltage: 120 volts, 1 phase, 60 Hz.
 - 3. 2 #10, plus ground, 3/4" c.
 - 4. Use manual motor starter switch with overloads and with pilot light for disconnect switch.
 - 5. Connect unit provided control switch as recommended by manufacturer. (3/4" c.)

END OF SECTION

SECTION 26 05 19
BUILDING WIRE AND CABLE

PART 1 – GENERAL

1.1 RELATED DOCUMENTS

- A. The provisions of the General Conditions, Supplementary Conditions, and the Sections included under Division 1, General Requirements, are included as a part of this Section as though bound herein.

1.2 SUMMARY

- A. Provide all equipment, labor, material, accessories, and mounting hardware to properly install all conductors and cables rated 600 volts and less for a complete and operating system for the following:
 - 1. Building wire and cable.
 - 2. Wiring connectors and connections.
- B. All sizes shall be given in American Wire Gauge (AWG) or in thousand circular mils (MCM/KCMIL).

1.3 REFERENCES

- A. ANSI/NFPA 70 - National Electrical Code.
- B. ANSI/Fed. Spec J-C 30B – Metal Clad Cables, Interlocking Galvanized Steel Tape Armor.

1.4 SUBMITTALS

- A. Product Data: Submit catalog cut sheet showing, type and UL listing of each type of conductor, connector and termination.

1.5 QUALIFICATIONS

- A. Manufacturer: Company specializing in manufacturing products specified in this Section with minimum five years experience.

1.6 REGULATORY REQUIREMENTS

- A. Conform to requirements of ANSI/NFPA 70.
- B. Furnish products listed and classified by Underwriters Laboratories, Inc. as suitable for purpose specified and shown.

1.7 PROJECT CONDITIONS

- A. Verify that field measurements are as shown on Drawings.
- B. Wire and cable routing shown on Drawings is approximate unless dimensioned. Route wire and cable as required to meet Project Conditions.

Martin County School District

- C. Where wire and cable routing is not shown, and destination only is indicated, determine exact routing and lengths required.

1.8 COORDINATION

- A. Determine required separation between cable and other work.
- B. Determine cable routing to avoid interference with other work.

PART 2 – PRODUCTS

2.1 BUILDING WIRE AND CABLE

- A. Description: Single conductor insulated wire.
- B. Conductor: Copper.
- C. Insulation Voltage Rating: 600 volts.
- D. Insulation: ANSI/NFPA 70, Type THHN/THWN and XHHW.

PART 3 – EXECUTION

3.1 GENERAL

- A. Install products in accordance with manufacturer's instructions.
- B. Conductors #10 AWG or #12 AWG shall be 600 volt type THWN/THHN unless noted otherwise, rated 90 degrees C dry, 75 degrees C wet.
- C. Conductors #8 AWG and larger shall be type THWN-2/THHN unless noted otherwise, rated 90 degrees C wet or dry.
- D. Use solid conductor for feeders and branch circuits 14 AWG and smaller (except for control circuits).
- E. Use conductor not smaller than 12 AWG for power and lighting circuits.
- F. Neatly train and lace wiring inside boxes, equipment, and panelboards.
- G. All conductors shall be installed in raceway.
- H. Conductor sizes indicated on circuit homeruns or in schedules shall be installed over the entire length of the circuit unless noted otherwise on the drawings or in these specifications.
- I. Before installing raceways and pulling wire to any mechanical equipment, verify electrical characteristics with final submittal on equipment to assure proper number and AWG of conductors. (As for multiple speed motors, different motor starter arrangements, etc.).
- J. Coordinate all wire sizes with lug sizes on equipment, devices, etc. Provide/install lugs as required to match wire size.
- K. Where oversized conductors are called for (due to voltage drop, etc.) provide/install lugs as required to match conductors, or provide/install splice box, and splice to reduce conductor size to match lug size.

3.2 EXAMINATION

- A. Verify that interior of building has been protected from weather.
- B. Verify that mechanical work likely to damage wire has been completed.

3.3 PREPARATION

- A. Completely and thoroughly swab raceway before installing wire.

3.4 WIRING METHODS

- A. Use only building wire, type (THHN/THWN for #10 and #12 and THHN/THWN-2 for #8 and larger) insulation, in raceway or cable (AC or MC) unless noted otherwise.
- B. Wiring in vicinity of heat producing equipment: Use only XHHW insulation, in raceway.
- C. Conductors installed within fluorescent fixture channels shall be Type THHN or XHHW, rated 90 degrees C dry. Conductors for all other light fixtures shall have temperature ratings as required to meet the UL listing of the fixture; however, in no case shall the temperature rating be less than 90 degrees Centigrade. Remove incorrect insulation types in new work.
- D. Pre-manufactured cable systems for power distribution are not allowed.
- E. MC Type cable is not allowed.

3.5 INTERFACE WITH OTHER PRODUCTS

- A. Identify wire and cable under provisions of Section Identification for Electrical Systems.
- B. Identify each conductor with its circuit number or other designation indicated on Drawings.
- C. Identify neutrals with its associated circuit number(s).

3.6 FIELD QUALITY CONTROL

- A. Perform field inspection and testing under provisions of the General Requirements of the Contract Documents and Section Tests and Performance Verification of Electrical Systems.
- B. Inspect wire for physical damage and proper connection.
- C. Measure tightness of bolted connections and compare torque measurements with manufacturer's recommended values.
- D. Verify continuity of each branch circuit conductor.

3.7 PULLING

- A. No wire shall be pulled until the conduit system is complete from pull point to pull point and major equipment terminating conduits have been fixed in position.
- B. Mechanical pulling devices shall not be used on conductors sized #8 and smaller. Pulling means which might damage the raceway shall not be used.
- C. Use only powdered soapstone or other pulling lubricant acceptable to the A/E. Compound or lubricant shall not cause the conductor or insulation to deteriorate.
- D. All conductors to be installed in a common raceway shall be pulled together. The manufacturer's recommended pulling tensions shall not be exceeded.
- E. Bending radius of insulated wire or cable shall not be less than the minimum recommended by the manufacturer.
- F. Where communications type conductors are installed, special requirements shall apply as outlined under that specific system detail specifications.

3.8 CONTROL AND SIGNAL CIRCUITS

- A. For control and signal circuits above 50 VAC, conductors shall be #14 AWG minimum size, Type XHHW or THWN-THHN as permitted by NFPA 70, within voltage drop limits, increased to #12 AWG as necessary for proper operation.
- B. For control and signal circuits 50 VAC and below, conductors, at the Contractor's option, may be #16 AWG, 300 volt rated, PVC insulated, except where specifically noted otherwise in the contract documents.
- C. Conductor insulation for Fire Alarm Systems shall be as accepted by Code Inspection Authority only. Wire acceptance by the A/E shall not supersede this final Acceptance for conditions of this specific project.
- D. Install circuit conductors in conduit.
- E. Circuit conductors to be stranded.

3.9 COLOR CODING

- A. All power feeders and branch circuits No. 6 and smaller shall be wired with color-coded wire with the same color used for a system throughout the building. Power feeders above No. 6 shall either be fully color-coded or shall have black insulation and be similarly color-coded with tape or paint in all junction boxes and panels. Tape or paint shall completely cover the full length of conductor insulation within the box or panel.
- B. Unless otherwise accepted or required by A/E to match existing, color-code shall be as follows: Neutrals to be white for 120/208V system, natural grey for 277/480V system; ground wire green, bare. 120/208V, Phase A - black; Phase B - red; Phase C - blue. 480/277V, Phase A brown; Phase B - orange; Phase C - yellow. All switchlegs, other voltage system wiring, control and interlock wiring shall be color-coded other than those above.

3.10 TAPS/SPLICES/CONNECTORS/TERMINATIONS

- A. Clean conductor surfaces before installing lugs and connectors.
- B. Make splices, taps, and terminations to carry full ampacity of conductors with no perceptible temperature rise.
- C. Power and lighting conductors shall be continuous and unspliced where located within conduit. Splices shall occur within troughs, wireways, outlet boxes, or equipment enclosures where sufficient additional room is provided for all splices. No splices shall be made in in-ground pull boxes (without written acceptance of engineer).
- D. Splices in lighting and power outlet boxes, wireway, and troughs shall be kept to a minimum, pull conductors through to equipment, terminal cabinets, and devices.
- E. No splices shall be made in junction box, and outlet boxes (wire No. 8 and larger) without written acceptance of Engineer.
- F. No splices shall be made in communications outlet boxes, pull boxes or wireways (i.e., fire alarm, computer, telephone, intercom, sound system, etc.) without written acceptance of Engineer. Pull cables through to equipment cabinets, terminal cabinets and devices.

- G. Allow adequate conductor lengths in all junction boxes, pull boxes and terminal cabinets. All termination of conductors in which conductor is in tension will be rejected and shall be replaced with conductors of adequate length. This requirement shall include the providing by the Contractor of sleeve type vertical cable supports in vertical raceway installations provided in pullboxes at proper vertical spacings.
- H. A calibrated torque wrench shall be used for all bolt tightening.
- I. Interior Locations:
 - 1. All (non-electronic systems) copper taps and splices in No. 8 or smaller shall be fastened together by means of "spring type" connectors. All taps and splices in wire larger than No. 8 shall be made with compression type connectors and taped to provide insulation equal to wire.
- J. Exterior Locations:
 - 1. Make splices, taps and terminations above grade in splice or termination cabinets. Do not splice any cable in ground or below finished grade.
 - 2. All taps and splices shall be made with compression type connectors and covered with Raychem heavywall cable sleeves (type CRSM-CT, WCSM or MCK) with type "S" sealant coating with sleeve kits as per manufacturer's installation instructions or be terminated/connected to terminal strips in above grade terminal boxes suitable for use.
 - 3. Provide and install above grade termination cabinets sized to meet applicable codes and standards, where required for splicing.

END OF SECTION

SECTION 27 41 00
AUDIO-VISUAL EQUIPMENT

PART 1 GENERAL

1.1 SCOPE OF WORK

- A. Provide installation, labor, services, and materials including cabling, connections, accessories, and associated testing and commissioning of audio-visual equipment for fully operational/turn-key, integrated system.
- B. Audio-visual equipment includes interactive flat panel and wall mounted screens.
- C. Equipment locations are as indicated on floor plans, elevations and equipment schedules.

1.2 RELATED SECTIONS

- A. Section 01 22 00 – Unit Prices.
- B. Section 01 25 13 – Product Substitution Procedures.
- C. Section 01 31 00 – Project Coordination.
- D. Section 01 33 00 – Submittal Procedures.
- E. Section 01 42 00 – References.
- F. Section 01 45 00 – Quality Control.
- G. Section 01 78 00 – Clos out Submittals.
- H. Section 01 91 00 – Commissioning.
- I. Section 10 11 00 – Visual Display Surfaces.
- J. Section 27 05 00 – Common Work Results for Communications Systems.
- K. Section 27 05 26 – Grounding and Bonding for Communications Systems.
- L. Section 27 05 28 – Pathways for Communications Systems.
- M. Section 27 15 00 – Communications Horizontal Cabling.
- N. Section 27 15 43 – Communications Faceplates and Connectors.
- O. Section 27 16 00 – Communications Connecting Cords and Devices.
- P. Section 27 18 00 – Communications Testing.
- Q. Section 27 70 00 – Audio Enhancement System.

1.3 REFERENCES

- A. See Section 01 42 00 – References for additional reference standards, definitions, abbreviations and acronyms.

1.4 QUALITY ASSURANCE

- A. Comply with Section 01 45 00 – Quality Control for project requirements.
- B. Installer Qualifications:
 - 1. Installer shall maintain local service department within a 150-mile radius of project, stock sufficient replacement parts to support specified warranty service and experienced and specialized in performing work specified.
 - 2. Installer shall document capability of providing 24-hour service for emergency calls, after-hours service with email and telephone numbers being used for such service.
- C. Manufacturers Qualifications:
 - 1. Equipment, components and accessories specified shall be manufactured by company with minimum of three (3) years of documented experience.

1.5 SUBMITTALS

- A. Comply with Section 01 33 00 – Submittal Procedures.

- B. Product Data:
 - 1. Provide listing of components, materials and services required for complete and fully operational system.
 - 2. List manufacturer, model and serial number (by room location), quantity provided, and short description of each item. Include manufacturer's catalog cuts.
 - 3. Provide product specifications for each component and detail drawings for overall system/subsystem design.
 - 4. Indicate product features and performance data and clearly indicate deviations, if any, from design criteria, accompanied by explanation of associated losses in system capability. Information shall indicate description of signal limitations.
 - 5. Provide verification of Dealerships, products represented, personnel training Certificates, State of Florida and local Licensing certificates.
 - 6. Provide details regarding and Conditions or Exceptions, if any, for installer to successfully complete contract within design criteria and price quotation.
- C. Submit Shop Drawings listing each product and indicating product locations, and installation details.

1.6 COMMISSIONING

- A. Comply with Section 01 91 00 – Commissioning requirements.
- B. Test each piece of equipment for proper operation by manufacturer's approved technician prior to project substantial completion.

1.7 CLOSEOUT SUBMITTALS

- A. Provide Project Record Drawings in accord with Section 01 78 00 – Closeout Submittals.
- B. Provide 3 year's material and labor warranty for equipment and installation.

1.8 SERVICE CONTRACT

- A. Bid shall include unit prices in accord with Specification 01 22 00 – Unit Prices.
 - 1. Provide fixed unit costs for period of five years from project substantial completion for projector replacement lamps, filters, and remote control batteries to be ordered from manufacturer's local representative on as needed basis with 72 hr. delivery.

PART 2 MATERIALS

2.1 APPROVED MANUFACTURERS

- A. Only products of manufactures listed are approved. Other manufacturers requesting product approval shall comply with Section 01 25 13 – Substitution Procedures.
- B. Whiteboards are specified in Section 10 11 00 – Visual Display Boards.

2.2 WALL MOUNTED INTERACTIVE FLAT PANEL SCREENS

- A. Approved Manufacturer: Promethean World, PLC, 1165 Sanctuary Parkway, Suite 400, Alpharetta, GA 30009; Tel: 888-652-2848; Fax: 678-762-7700; Website: www.prometheanworld.com.
- B. Interactive Flat Panel: ActivPanel Touch General Specifications:
1. Aspect Ratio: 16:9.
 2. Pixel Fault Resilience Class: ISO 13406-2, Class II.
 3. Viewing Angle: 178°.
 4. Surface: ActivGlide® 4mm acid-etched tempered glass.
 5. Number of Touches: 10.
 6. Touch Resolution: 32768 x 32768.
 7. First Touch Response Time: <20ms.
 8. Digitizing Technology: Infrared.
 9. Connection to Computer: USB "B" 2.0 x 1.
 10. Stereo Speakers: Integral 2 x 10W.
 11. Communication and Control Port: RS232 In/Out.
 12. Presentation Functions: Blank Screen, Freeze Frame.
 13. Open Pluggable Specification (OPS) Slot: 1.
 14. VESA Mount Point (NUC/Mini): 4 x M4 (VESA 100 and VESA 75).
 15. VESA Mount Point (Wall/Stand) 4 x M8 (VESA 600 x 400).
 16. Operating Temperature: 5° C to 40° C (41° F to 104° F).
 17. Storage Temperature: 2° C to 55° C (36° F to 131° F).
 18. Power: AC120-240V.
 19. System Requirements: Windows (XP SP3/Vista/7/8); Mac OSX 10.6-10.10; Linux Ubuntu 12.04-14.04; Chrome OS.
 20. Interactive Panel Accessories:
 - a. VESA mount bolts.
 - b. 5m (16') power cable.
 - c. Infrared remote control.
 - d. VGA cable.
 - e. HDMI cable.
 - f. 3.5mm audio cable.
 - i. 2 pens.
- C. Interactive Flat Panel: ActivPanel Touch 70" Product Specifications:
1. Nominal Size: 70".
 2. Resolution: Full HD 1080p ().
 3. Optimum Resolution: 1920 x 1080 @ 60 Hz.
 4. Contrast Ratio: 4000:1.
 5. Response Time: 8ms.
 6. Active Area Dimensions: 1549mm x 872mm (61" x 31.3").
 7. Active Area Diagonal: 1778mm (70").
 8. Panel Usage Type: DID.
 9. Brightness (Typical): 400 cd/m² (400 Nits).
 10. Power Consumption: 310W Max.
 11. Dimensions: 1637mm x 981mm x 96mm (64.4" x 38.6" x 3.8").
 12. Net Weight: 72kg (159lbs).
- D. Video and Audio Input:
1. HDMI: x4.
 2. VGA (D-Sub): x1.
 3. Component in (Video Y.Pb. Pr & Stereo Audio): x1.
 4. AV-In (Composite Video & Stereo Audio): x1.
 5. PC Audio (3.5mm): x1.
 6. USB 2.0 (for media playback): x1.

Martin County School District

7. USB 3.0 (for HD medial playback): x1.
- E. Video and Audio Output:
1. HDMI Out: x1.
 2. AV-Out (Composite Video & Stereo Audio): x1.
 3. Digital Audio Out (coaxial): x1.
 4. Headphone Socket: x1.
- F. Locations:
1. Classrooms, Resource Rms, Skills Development Labs, Science, Vocational and Technical Labs, Art and Music Labs.
- 2.3 WALL MOUNTED VIDEO SCREENS (TV's for Principals' Offices, Large Conference Rms, and other Assembly Spaces where indicated)
- A. Approved Manufacturer: Sharp Electronics Corp., Sharp Plaza, Mahwah, NJ 07495-1163; Tel: 201-529-8200, 800-237-4277; Website: www.sharppusa.com.
- B. Video Screen Description:
1. Model No: Sharp AQUOS 65" (165.1cm), LC-65LE654U.
 2. Size: 2.76" deep x 33.43" high x 57.44" wide with 65" diagonal dimension screen.
 3. Weight: 56.22 lbs (kg).
- C. Video Screen Specifications:
1. Maximum Resolution: 1920 x 1080.
 2. Vertical Resolution: 1080p.
 3. Maximum Contrast Rate: 4,000,000.
 4. Display Type: LED.
 4. Video Input(s): Component Video/Composite video (HDMI).
 5. Video Output(s): Component Video/Composite video.
 6. Network Compatibility: Built-in Wi-Fi.
 7. Number of Analog Audio Outputs: 1.
 8. Number of Digital Optical Audio Outputs: 1.
 9. RF Antenna Input: Yes.
 10. Simulated Surround: Yes.
 11. Sleep Timer: Yes.
 12. Speaker Output: 20 watts.
 13. V-Chip: Yes.
 14. Viewing Modes: Game.
 15. Volume Leveler: Yes.
- 2.4 CEILING PROJECTOR (for Assembly Spaces, Auditorium, Gymnasium, Media Center, Multipurpose and Lab Areas where indicated).
- A. Approved Manufacturer: Epson America, Inc., 3840 Killroy Way, Long Beach, CA 90806. Tel: Fax: Website: www.epson.com.
- B. Projector Performance Characteristics:
1. Projection System: EPSON Powerlite 7900P (ceiling bracket mounted).
 2. Driving Method: Poly-silicon TFT Active Matrix.
 3. Pixel Method: 786,432 dots (1024 x 768) x 3.
 4. Color Light Output: 3000 lumens.
 5. White Light Output: 3000 lumens.
 6. Aspect Ratio: 4:3.
 7. Native Resolution: 1024 x 768 (XGA).
 8. Lamp Type: 215W UHE.
 9. Lamp Life:
 - a. ECO Mode: Up to 4000 hours.
 - b. Normal Mode: Up to 3000 hours.

10. Size (Projected Distance):
 - a. 4:3: 56" – 93".
 - b. 16:9: 53" – 88".
 - c. 16:10: 52" – 85".
 12. Keystone Correction: Manual:
 - a. Vertical: +/- 5 degrees.
 - b. Horizontal: +/- 5 degrees.
 13. USB Plug'n Play:
 - a. Mac® 10.5 or later.
 - b. USB Plug'n Play for Windows® 2000 or later.
 14. Contrast Ratio: Up to 3000:1.
 15. Color Reproduction: 16.77 million colors.
- D. Projection Lens:
1. Type: Manual Focus.
 2. F-Number: 1.80.
 3. Focal Length; 3.71mm.
 4. Throw Ratio Range:
 - a. 4:3: 0.33 – 0.44.
 - b. 16:9: 0.27 – 0.37.
 - c. 16:10: 0.27 – 0.37.
 5. Zoom Ratio: Digital zoom 1.0 – 1.35x.
- E. Lenses shall be installed after installer determines most appropriate lens for location and use.

2.5 DOCUMENT CAMERA

- A. Approved Manufacturer: Samsung Techwin America, Inc., 100 Challenger Rd., #700, Ridgefield Park, NJ 07660; Tel: 1-201-325-6920; Fax: 1-201-373-0124; Website: www.samsungpresenterusa.com.
- B. Performance Characteristics:
 1. Optical System:
 - a. Lens: F = 2.5 (Wide); F = 3.2 (Telephoto), F=4.1, 6X Zoom Lens.
 - b. Shooting Area: Max: 420 x 297mm.
 - c. Zoom: 48X Zoom (Optical 6X/Digital 8X).
 - d. Focus: Auto focus/manual.
 - e. Iris: Auto (with fine level adjustment).
 2. Video:
 - a. Pick Up Device: 1/3 Progressive Scan CMOS Image Sensor.
 - b. Total Number of Pixels: 1384 (H) x 1,076(V), 1.49 pixels.
 - c. Number of Elective Pixels: 1329 (H) x 1,049(V), 1.39 pixels
 - d. Frame Rate: SXGA: 30 fps.
 - e. VGA Output: SXGA (1,080 x 1.024 resolution); XGA (1,024 x 768); HD (1,280 x 720p), 1,920 x 1,080p.
 - f. Resolution: H: 700 TV lines/V: 700 TV lines.
 3. Functions:
 - a. White Balance: AWC (One touch)/ATW/Manual.
 - b. Aperture Function: Image mode/Test mode/Custom mode.
 - c. Noise Reduction: Available (Low light presenter with 2D/3D NR).
 - d. Preset Function: Up to four user settings.
 - e. Image Freeze: Available.
 - f. Image Rotation: Available (Flip/Mirror/180 degree).
 - g. Image Save: Photo: JPEG, BMP; Movie: MEGG-4, 640 x 512@ 30fps with Audio (Mic), Internal memory and SDHC card (up to 32GB).
 - h. Image Playback: Photo: Slide show/3 x 3 (9 split); Movie: Internal movie player.
 - i. USB I/F: USB 2 support.
 - j. Input Selection: 2 Channels (Internal:1, External: 1).

- k. Illumination: LED illumination system.
- 4. Interface:
 - a. Input Port: VGA In/Out: 15 pin DSUB Connector x 1; Audio In: 3.5 jack x 1 (Built-In Microphone).
 - b. Output Port: DVI Out: DVI Connector; Audio Out: 3.5 jack x 1; RS-232C: 3.5 jack x 1.
 - c. I/F Port: USB: USB B-type x 1; Memory I/F: SD Slot x 1.
 - d. Power Input: 12V DC In x 1.
- 5. General:
 - a. Operating Temperature: +5° C-+35° C.
 - b. Operating Humidity: 30%-90%.
 - c. Power; 12V DC (Adapter input: 100V AC- 240V free voltage, 50/60Hz, output: 12V, 4A.
 - d. Dimensions: 14.41 inches (366mm) W x 16.69 inches (424mm)H x 13.74 inches (349mm)D.
 - e. Weight; 7.72 lbs. (3.5kg).
- 6. Accessories:
 - a. Remote controller.
 - b. USB Cable.
 - c. DVI Cable.
 - d. VGA Cable.
 - e. Audio Cable.

C. Approved Document Camera: SAMSUNG: Model SPD 860.

2.6 DVD RECORDER

- A. Approved Manufacturer:
 - 1. Toshiba America Electronic Components, Inc., 19900 McArthur Blvd., Suite 400., Irvine, CA 92612; Tel: 949-623-2900; Fax: 949-474-1330; Website: www.toshiba.com.
- B. Video:
 - 1. Video Resolution: 1080p.
 - 2. Playable Disk Types: VCD, DVD+R, DVD-RW, SVCD, CD-DA, CD-R, DVD-R, CD-RW, DVD-Video, DVD-RW.
 - 3. Progressive Scan 3.2 Pulldown: Progressive Out.
- C. Audio:
 - 1. WMA and MP3 Playback.

H. Approved DVD Recorder: Toshiba DVR670.

2.7 DISTRIBUTION AMPLIFIER

- A. Approved Manufacturer: Extron Electronics, USA, 1230 South Lewis St., Anaheim, CA 92805; Tel: 800-633-9876, 714-491-1500; Fax: 714-491-1517; website: extron.com.
- B. Performance Characteristics:
 - 1. Video:
 - a. Gain: Unity
 - b. Peaking: Fixed.
 - c. Bandwidth: 300 MHz (-3 dB).
 - 2. Video Input:
 - a. Signal type: 1 VGA-QXGA RGBHV, RGsB, RsGsBs, HDTV component video (with adapter).
 - b. Connectors: 1 male 15-pin HD cable (built-in).
 - c. Pin connections: ID bits on pins 4, 11, 12, and 15 are passed through to local monitor output (loop-through). Pin 9 is floating.
 - d. Nominal level: 1.0 Vp-p for Y of component video.
 - e. Max/Min. levels: Analog; 0.4 V to 1.4 Vp-p with no off-set at unity gain.
 - f. Impedance: 75 ohms.

- g. Horizontal frequency: 15-135 kHz.
 - h. Vertical frequency: 30-170 Hz.
 - i. Return loss; <-38 db @ 5 Mz.
3. Video Output:
- a. Number/signal type: 1 VGA-QXGA RGBHV, RGBS, RGsB, RsGsBs, HDTV component video (with adapter). 1 VGA-QXGA RGBHV, RGBS, RGsB, RsGsBs local monitor output/loop-through (ID bits are passed through).
 - b. Connectors: 2 female 15-pin HD.
 - c. Nominal level: 1.0 Vp-p for Y of component video. 0.7 Vp-p for RGB and for R-Y and B-Y of component video.
 - d. Impedance: 75 ohms.
 - e. Return loss; <-41 db @ 5 Mz.
 - f. DC offset: +/- 5 mV max. with input at 0 offset.
4. Sync:
- a. Input and output type: RGBHV, RGBS, RGsB, RsGsBs, bi-level and tri-level sync.
 - b. Input level: Analog or TTL, 1.7 V to 5 Vp-p.
 - c. Input impedance: 75 ohms or 10k ohms selectable.
 - d. Output impedance: 25 ohms (default) or 50 ohms selectable.
 - e. Max. propagation delay: 60 ns.
 - f. Max. rise/fall time: 4 ns.
 - g. Polarity: Positive or negative (follows input).
5. General:
- a. Attached External Power Source: 100 VAC to 240 VAC, 50-60 Hz, 4.5 watts, external; to 12 VDC, 1 A, regulated.
 - b. Power Input: 12 VDC. 0.2 A.
 - c. Temperature/Humidity:
 - (1) Storage: -40°F to +158° F(-40°C to +70° C)/10% to 90%, noncondensing.
 - (2) Operating: -40°F to +158° F(-40°C to +70°C),10% to 90%, noncondensing.
 - d. Cooling: convection, no vents.
 - e. Mounting rack: none.
 - f. Enclosure: plastic.
 - g. Enclosure dimensions: 1.5" (38 mm) H x 5.0" (127mm) W x 2.5" (64mm) D (Depth excludes connectors).
 - h. Weight: 1.6 lbs. (0.7 kg).
 - i. Warranty: 3 yrs. parts and labor.
- I. Approved Sound Distribution Amplifier: Extron P/2 DA2 Plus.
- 2.8 WIRE, CABLE, CONNECTIONS and ACCESSORIES
- A. Installer shall furnish and install appropriate cables in accord with Division 26-Electrical and Division 27-Communications Sections.
 - B. Baseband Video Cable for Local Origination: Coaxial type cable with copper center conductor, Teflon dielectric, tinned copper double braid shield providing 98% shield coverage. Cable is to have 75 ohm impedance, and shall have nominal attenuation of 0.24 dB/100' at 1 MHz and 0.78 dB/100' at 10 MHz. No discontinuity shall exist within 0-50 MHz band. Submit sweep test certification before installation. Cable shall be BELDEN #8281.
 - C. Broadband RF Cable for Local Origination: Coaxial type cable with copper center conductor, tinned copper braid shield providing 100% shield coverage. Cable is to have 75 ohm impedance, and it is to have nominal attenuation of 0.3 dB/100' at 1 MHz and 2.0 dB/100' at 100 MHz. No discontinuity is to exist within the 0-50 MHz band. Submit sweep test certification before installation. Cable shall be BELDEN #9248.
 - D. Audio Cable for Local Origination: Stranded 22 gage, two-conductor, twisted shielded copper pair, polyethylene conductor insulation, aluminum mylar foil shield providing 100% shield coverage, tinned copper drain conductor. Cable shall be BELDEN #8761.

- E. RGBHV Cables: Classroom/projectors shall have two HD15 SVGA interfaces. Install two high resolution 75 ohm video cables with HD15 Male ends field terminated at each end. Cables shall run from projector to 6 gang D21 wall plane at teacher's desk. One cable will be for Teacher PC and other cable is for document camera. Cable shall be BELDEN WV-YR49051.
- F. Patch cables: Supply video and audio patch cables necessary to connect teacher PC, Document Camera and audio system to D21. Supply Y cables, jumpers and amplifiers necessary to insure system functionality.
- G. Wallplate: 6-gang wallplate shall be provided for D21 wall outlets. Wallplate shall be one unit, permanently machined marked with jack/connector identifiers for audio and video. Wallplate shall house Voice, Data, Coax video, Quad power, Dual VGA ports and audio outputs for ceiling speakers and projector. Refer to Drawing for details.
- H. Cable Marker Labels: Labels shall be machine printed or typed and permanently attached to cables.

PART 3 EXECUTION

3.1 DELIVERY STORAGE AND HANDLING.

- A. Delivery, Storage and Handling:
 - 1. Deliver equipment in manufacturers unopened boxes and store in secure area until installation.
 - 2. Unbox equipment and remove all boxes and associated trash from site.
 - 3. Store and handle equipment in accord with manufacturer's instructions.

3.2 INSTALLATION

- A. Securely mount equipment plumb and square in place. Where equipment is installed in cabinets, provide mounting bolts in equipment fastening holes. Mounting bolts are to be provided with nylon washers between bolt heads and equipment.
- B. Install electronic equipment in appropriate equipment cabinets and/or racks.
- C. Install equipment ensuring appropriate ventilation to meet manufacturer's requirements.
- D. Confirm polarity and phasing of system components before installation. Connect to maintain uniform polarity and phasing.
- E. Wiring shall be free from ground loops, shorts, opens and reversals.
- F. Provide 12" service loop at each outlet. Leave service loops at equipment cabinets to allow operation of equipment outside cabinets and allow full access to rear of cabinets and installed equipment. Provide 36" service loop in ceiling above projector.
- G. Neatly tie electronic cables within equipment cabinets, housings, and terminal cabinets with Velcro fasteners at not more than 12" intervals. Install in accord with current EIA installation standards. Use FLEXO-WRAP Heavy Wall (HW 1½" black) to bundle cables at ceiling mount for projector.
- H. Provide individually labeled System cables at each end with typed or pre-printed cable marker labels. Handwritten labels are not permitted.
- I. Install with security-type fasteners for all open area equipment.
- J. Provide necessary installation hardware, cabling connectors and wall plates with connector interface.

3.3 EQUIPMENT COORDINATION

- A. Projector location shall be coordinated with reflected ceiling grid, and wall mounted accessories to avoid conflict with HVAC diffusers, speakers, fire sprinklers and light fixtures, marker boards and clocks.

- B. Projectors shall be centered on the projection screen, smartboard or markerboard in each room where indicated, mounted from the ceiling as indicated.

3.4 FIELD QUALITY CONTROL

- A. Field Testing:
 - 1. Measure and adjust for optimum signal quality and minimum signal loss for all audio, video and RGB signals using appropriate test equipment and standardized testing procedures.
 - 2. Measure and adjust for optimum signal-to-noise ratio and headroom of the system electronics.
 - 3. Measure and adjust systems to eliminate clipping, hum, noise, and RFI interference.
 - 4. Check quality of each signal at source and measure against quality of signal at various points of transmission through system. Correct significant signal distortion or loss.
 - 5. Use appropriate test equipment.
- B. Lenses shall be installed after installer determines most appropriate lens for projector location and use.

3.5 TESTING AND DEMONSTRATION

- A. Equipment shall be tested no later one week after substantial completion.
- B. Upon completion of system installation notify Owner's Project Manager that system is ready for testing and demonstration.
- C. Provide system test documentation with equipment warranties to Owner's Project Manager. Measurements, test results, instrumentation certifications shall be submitted prior to final testing and demonstration.
- D. Conduct tests and demonstrations in presence of Owner's Project Manager.
- E. Demonstrate system and equipment functions.
- F. Test and demonstrate that equipment functions properly and is ready for Owner's training sessions.
- G. Upon completion of equipment testing and demonstration, turn over equipment cabinet keys and non-installed equipment to Owner's Project Manager.

3.6 TRAINING

- A. Provide two separate 2 hour blocks of training to district staff in operation of audio-visual equipment including projectors, document cameras, sound distribution amplifier, and DVD Recorder. Owner shall select date and time for each training session.
- B. Provide operating and users guides to the Owner's Project Manager at first training session.
- C. Training sessions shall be video recorded with master and two (2) copies turned over to Owner's Project Manager within 7 days of last training session.

END OF SECTION