

**BID NUMBER: 0098**

**BID TITLE: HERITAGE PARK STAGE**

**BID ENVELOPE OR PACKAGE CONTAINING BID:**

**Bids MUST be received in a sealed envelope or package with the bid number, company name and opening date clearly marked. Failure to comply may result in rejection of your entire bid. Late bids, e-mailed bids and faxed bids will not be considered nor returned. Union County will not be responsible for any lost or misdirected mail.**



UNION COUNTY FINANCE DEPARTMENT  
300 MAIN STREET  
MAYNARDVILLE, TN 37807  
[ccook@unioncountyttn.org](mailto:ccook@unioncountyttn.org)  
(865) 686-5040 Phone  
(865) 329-7428 Fax



---

## BID NOTICE

Union County Government is currently accepting bids from responsible firms to provide a Structural Steel Package including labor, equipment and materials (steel beams and all necessary supplies) for the performance stage at Heritage Park (Union County Farmer's Market) located at 115 Durham Drive, Maynardville, TN 37807.

A request for the bid packet and inquiry regarding this bid must be submitted to [ccook@unioncountyttn.org](mailto:ccook@unioncountyttn.org) or found on the County Finance website at [www.unioncountyttn.gov](http://www.unioncountyttn.gov) under the solicitation section for Bids/RFP's.

Sealed bids must be submitted to:  
Union County Finance Office, 300 Main Street, Maynardville, TN 37807  
**ATTN: Bid 0098 – Heritage Park Stage.**

Bids will be accepted until **3:00 p.m.** local time on **May 18, 2021** at the Finance Office location at which time they will be opened and read aloud. Late bids, e-mailed bids and faxed bids will not be considered nor returned. Union County will not be responsible for any lost or misdirected mail. No bid can be withdrawn after the scheduled closing time for receipt of bids for sixty (60) calendar days. Union County Government reserves the right to reject any and all bids.

---

Sealed proposals subject to the **General Terms and Conditions** of this Formal Invitation and any other data attached or incorporated by reference. Proposals will be received in the Union County Finance Office until the date and time specified above and at that time publicly opened and read aloud. The Bid envelope must show the Bid Number, Name, and Opening Date

**Bid documents must be completed in ink or typed, signed in ink, and free from alterations, erasures or mark-throughs.**

## SECTION 1 - GENERAL TERMS AND CONDITIONS

**1.1 ALTERATIONS OR AMENDMENTS:** Alterations, amendments, changes, modifications or additions to this solicitation shall not be binding on Union County without prior written approval.

**1.2 NO CONTACT POLICY:** After vendor receives a copy of this bid, any contact initiated by any vendor with any Union County representative, other than the Finance Department, concerning this invitation for bid is prohibited and agreements made thereto will not be considered binding on Union County. Any such unauthorized contact may cause the disqualification of the bidder from this procurement transaction.

**1.3 QUESTIONS:** Any questions concerning the bid document must be submitted to [ccook@unioncountyttn.org](mailto:ccook@unioncountyttn.org) no less than ninety-six (96) hours before bid opening date.

**1.4 BID STAMP:** The bid/time stamp in the Union County Finance office will be the time of record.

**1.5 TAXES:** Union County is not liable for Federal excise or State sales tax. Tax exemption certificates will be provided upon request.

**1.6 CONFLICT OF INTEREST:** If requested by the Director of Finance, vendors must complete and submit a "Conflict of Interest Affidavit Statement" prior to contract award, see T.C.A. 5-14-114 and T. C. A. 12-4-101.

**1.7 NON-COLLUSION:** Vendors, by submitting a signed bid, certify that the accompanying bid is not the result of, or affected by, any unlawful act of collusion with any other person or company engaged in the same line of business or commerce, or any other fraudulent act punishable under Tennessee or United States law.

**1.8 NON-DISCRIMINATION:** Vendors, during the performance of this contract, will not discriminate against any employee or applicant for employment because of race, religion, sex, national origin or disability except where religion, sex, national origin or disability is a bona fide occupational qualification reasonably necessary to the normal operation of the contractor.

**1.9 SAME AS OR EQUIVALENT TO:** Vendors are to bid as specified herein or propose an approved equal. Determination of equality is solely Union County's responsibility. The designated brands are for reference purpose only, not a statement of preference. When an alternate manufacturer, brand, model or make is bid, Union County will determine if the item bid does meet or exceed the items as specified. If the bidder does not indicate that an alternate manufacturer, brand, model or make is being bid, it is understood that the item(s) bid are the same manufacturer, brand, model or make as was requested in the Invitation to Bid. Comparable products of other manufacturers will be considered if proof of comparability is contained in the bid. It shall be the responsibility of the vendors, including vendors whose product is referenced to furnish upon request catalog pages, brochures or other data as will provide an adequate basis for determining the quality and functional capabilities of the product offered. Failure to provide this data may be considered valid justification for rejection of bid.

**1.10 MULTIPLE BIDS/AWARDS:** Union County will consider multiple bids that meet specifications. Bid awards may include multiple approved vendors and the list of approved vendors may be added to or deleted from at any time.

**1.11 STATE OF TENNESSEE CONTRACTORS' LICENSE LAW (T.C.A. 62-6-119 b):** No bid will be opened or considered for which the total cost of the project is twenty-five thousand dollars (\$25,000) or more, unless the outside of the sealed bid envelope/package containing the bid provides the following information: the Company Name, the Contractor's license number, license classification, the date of the license expiration and that part of each license classification applying to the bid. In addition, each heating ventilation or air conditioning, plumbing and electrical subcontractor's license number, date of the license expiration and that part of each classification applying to the bid if the value of the work is \$25,000 or greater, must be notated. If the value of either the contractor or the subcontractor's work is less than \$25,000, the bid envelope/package containing the bid is to be notated with the phrase "Contractor or Subcontractor's Bid is Less than \$25,000" after each appropriate heading. In the case of joint ventures, each party submitting the bid must provide this information. If no subcontractors are being used, the outside of the envelope/package containing the bid must state, "No Subcontractors are being used on this project."

**1.12 ACCEPTANCE:** Vendors shall hold their price firm and subject to acceptance by Union County for a minimum period of sixty (60) working days from the date of the bid opening, unless otherwise indicated in their bid. to be supplied, their conformity with specifications, their suitability to the requirements of Union County and the delivery terms. Any or all bids may be rejected for good cause.

**1.13 BID AWARDS:** Bids will be awarded to the lowest and best bidder, taking into consideration the qualities of the articles to be supplied, their conformity with specifications, their suitability to the requirements of Union County and the delivery terms. Union County also reserves the right to not award this bid.

**1.14 PROTEST:** Any vendor wishing to protest the bid award shall notify in writing the Union County Director of Finance, 300 Main Street, Maynardville TN 37807. No protest will be accepted, except those protests made in writing and received within (10) ten calendar days of the bid award. Protests must be in writing and envelopes/package containing protest must be clearly marked with bid number and words "BID PROTEST". The Director of Finance, in conjunction with the Finance Committee, and with the advice and counsel of the County Attorney, shall review and make a final decision as to any bid protest. Appeals shall be filed in the Circuit or Chancery Courts of Union County within sixty (60) days of the final decision.

**VENDORS PLEASE NOTE: UNION COUNTY WILL NOT STOP THE PURCHASE PROCESS. THE PURCHASE MAY BE COMPLETED OR THE PROJECT MAY BE RE-BID WHILE THE PROTEST PROCEDURE IS STILL IN OPERATION. IF A RE-BID IS MADE, THE PROTESTING VENDOR SHOULD SUBMIT A NEW BID. OTHERWISE, THEY WILL BE WITHOUT A BID ON THE RE-BID. FURTHER, THE RE-BIDDING WILL NOT END THE APPEALS PROCESS. IT WILL CONTINUE UNTIL A FINAL DECISION IS REACHER OR THE COMPLAINANT WITHDRAWS THE APPEAL.**

**1.15 DELIVERY:** Bid pricing is to include complete supply and delivery to Union County, Tennessee. Vendors are to state the delivery time in the bid. Union County requires that vendors deliver all products "free on board" to final destination unless indicated otherwise in their bid, reference Terms & Conditions section 2.4.

**1.16 PROOF OF FINANCIAL AND BUSINESS CAPABILITY:** Bidders must, upon the request of Union County, provide satisfactory evidence of their ability to furnish products or services in accordance with the terms and conditions of these specifications. Union County will make the final determination as to the bidder's ability.

**1.17 VENDOR'S DEFAULT:** Union County reserves the right, in case of vendor default, to procure the articles or services from other sources and hold the defaulting vendor responsible for any excess costs occasioned thereby.

**1.18 DUPLICATE COPIES:** Union County requires that all vendors submit one original and one exact copy of their bids, including brochures; unless additional copies are requested in bid specifications.

**1.19 DRUG-FREE WORKPLACE:** Under the provisions of Tennessee Code Annotated §50-9-113 enacted by the General Assembly effective 2001, all employers with five (5) or more employees who contract with either the state or a local government to provide construction services are required to submit an affidavit stating that they have a drug free workplace program that complies with Title 50, Chapter 9, in effect at the time of submission of a bid at least to the extent required of governmental entities. The statute imposes other requirements on the contractor and contractors should consult private legal counsel if legal questions arise under this section or any other provision of this document. All contractors shall provide a written affidavit signed by the principal officer of a covered employer acknowledging that the contracting entity is in compliance with the Drug Free Workplace laws of State of Tennessee.

**1.20 RESTRICTIVE OR AMBIGUOUS SPECIFICATIONS:** It is the responsibility of the bidder to review the entire Invitation to Bid document and to notify the Finance Department if the Invitation to Bid is formulated in a manner that would unnecessarily restrict competition or if it is ambiguous in what is being requested. The Director of Finance must receive questions regarding the specifications or bid procedures not less than seventy-two (72) hours prior to the time set for the bid opening.

**1.21 SCHOOL CAFETERIA BIDS:** If this bid is for Union County School's Cafeteria Food Service Department, bidders must be in compliance with Section 104(d) of the William F. Goodling Child Nutrition Reauthorization Act of 1998 which requires school and institutions participating in the National School Lunch Program (NSLP) and School Breakfast Program (SBP) to "Buy American" to the maximum extent practicable.

**1.22 TERMINATION:** Union County reserves the right to terminate this contract in whole or in part with thirty (30) days written notification to the contractor. In the event of termination, the County shall not be liable for any costs other than the cost of services performed and materials delivered and accepted prior to termination date.

**1.23 OSHA SAFETY:** The Contractor is responsible for training their employees in Safety and Health Regulations for the job, assuring compliance with Tennessee Occupational Safety and Health regulations and any other Regulatory Agency.

**1.24 PERFORMANCE BOND:** A standard surety or performance bond or an irrevocable letter of credit in favor of Union County Government at a federally insured financial institution will be required to be submitted with bid, if indicated in section four, item six insurance requirement checklist.

**1.25 BACKGROUND CHECKS:** Contractors shall comply with Public Chapter 587 of 2007, as codified in Tennessee Code Annotated Section 49-5-413, which requires all contractors to facilitate a criminal history records check conducted by the Tennessee Bureau of Investigation and the Federal Bureau of Investigation for each employee prior to permitting the employee to have contact with students or enter school grounds when students are present.

**1.26 AWARD RESULTS:** As soon as practicable after proposal or bid evaluations, the award results will be posted on Vendor Registry. Interested parties may request results by contacting [ccook@unioncountyttn.org](mailto:ccook@unioncountyttn.org). Individual notices are normally not mailed or e-mailed except to the successful vendor.

**1.27 PRICE INCREASE/DELIVERY CHARGES:** Request for price or delivery charge increases must be received in writing 30-days prior to implementation. The Union County Director of Finance will review requests and make a determination to continue or cancel services.

**1.28 INDEMNIFICATION/HOLD HARMLESS:** Contractor shall indemnify, defend, save and hold harmless Union County and, its officers, agents and employees from all suits, claims, actions or damages of any nature brought because of, arising out of, or due to breach of the agreement by Contractor, its subcontractors, suppliers, agents, or employees or due to any negligent act or occurrence or any omission or commission of Contractor, its subcontractors, suppliers, agents or employees.

**1.29 DECLARATIVE STATEMENT:** Any statement or words (i.e.: must, shall, will, etc) are declarative statements and the proposer must comply with the condition. Failure to comply with any such condition may result in their bid being non-responsive and disqualified.

**1.30 WAIVING OF INFORMALITIES:** Union County reserves the right to waive minor informalities or technicalities when it is in the best interest of Union County.

**1.31 APPROPRIATION:** In the event no funds are appropriated by Union County for the goods or services in any fiscal year or insufficient funds exist to purchase the goods or services, then the Contract shall expire upon the expenditure of previously appropriated funds or the end of the current fiscal year, whichever occurs first, with no further obligations owed to or by either party.

**1.32 ASSIGNMENT:** Contractor shall not assign or sub-contract this agreement, its obligations or rights hereunder to any party, company, partnership, incorporation or person without the prior written specific consent of Union County.

**1.33 QUANTITIES:** Union County does not guarantee quantities to be purchased off this bid.

**1.34 UNIT PRICE:** Unit price for each unit bid shall be shown and such price shall include packing unless otherwise specified. A total shall be entered in the amount column of the pricing page for each item bid. In case of discrepancy between any unit price and an extended price, the unit price will be presumed to be correct, subject, however, to correction to the same extent and in the same manner as any other mistake.

**1.35 MODIFICATION OR WITHDRAWAL OF BIDS:** When it is certain that a mistake has been made in the preparation of the bid, a request will be made to the bidder to confirm the bid. Provisions must be made so that mistakes can be taken care of and the ambiguity resolved satisfactorily. Bids may be modified or withdrawn by written notice received in the Finance Department prior to the time and date set for the bid opening. The changes or withdrawal of the bids should be in writing and signed by an official of the company. The envelope containing the modification should clearly state "modification to bid: Either the entire bid or a particular item may be withdrawn or modified in this manner.

**1.36 PRE-BID CONFERENCES:** Attendance at Pre-bid Conference is strongly encouraged. When deemed necessary a Mandatory Pre-bid Conference will be held. A company representative MUST be in attendance and sign the Pre-bid sign-in sheet in order to be awarded the bid.

**1.37 ADDENDUM:** Union County Government reserves the right to amend this solicitation by addendum. Addendum will be emailed up to 48 hours in advance of the bid/proposals due date and time. It is the bidder's responsibility to check for addendum. If in the County's opinion revisions are of such a magnitude, the deadline for this solicitation may be extended in an addendum. In addition, addendum can change specifications, reply sheets, and times and dates for pre-bid meetings as well as due dates/deadlines for questions and bids/proposals.

**BID NUMBER: 0098**  
**BID TITLE: HERITAGE PARK STAGE**

**SCOPE OF WORK:**

To provide the necessary labor and materials to fabricate the stage per the drawings provided.

Fabrication & welding to conform to AISC & AWS D1.1 industry standards.

<b><u>BID NUMBER: 0098</u></b> <b><u>BID TITLE: HERITAGE PARK STAGE</u></b>
--

**Award:**

The contract award, if made, will be to the vendor whose bid meets the specifications and conditions set forth, and whose bid is most advantageous to Union County. Price shall be an evaluation factor as well as the qualifications and ability of the vendor to perform the necessary work, and past performance history. Union County reserves the right to reject any and all bids submitted.

**Response Submission:**

In order to facilitate the bid evaluation process, one (1) original and one (1) exact copy of the bid must be submitted to the Purchasing Agent. All bids must be packaged, sealed, and show the following information on the outside of the package:

Company's Name and Address  
Bid Number and Title and Bid Due Date and Time

Submit to:  
Union County Finance Department  
Attn: Carrie Cook  
300 Main Street  
Maynardville, TN 37807

**BID NUMBER: 0098**  
**BID TITLE: HERITAGE PARK STAGE**

**References:**

The vendor must be able to provide a list of three (3) references, including the name, complete address, contact person, phone number, and length of time services have been provided for other local government or school organizations or corporations for which the vendor provided Copy Machines and Services in the past five years.

Name: \_\_\_\_\_  
Address: \_\_\_\_\_  
Contact Person: \_\_\_\_\_  
Phone Number: \_\_\_\_\_  
Period of time services were provided: \_\_\_\_\_

Name: \_\_\_\_\_  
Address: \_\_\_\_\_  
Contact Person: \_\_\_\_\_  
Phone Number: \_\_\_\_\_  
Period of time services were provided: \_\_\_\_\_

Name: \_\_\_\_\_  
Address: \_\_\_\_\_  
Contact Person: \_\_\_\_\_  
Phone Number: \_\_\_\_\_  
Period of time services were provided: \_\_\_\_\_

**Union County reserves the right to reject any and all bids and to negotiate with an applicant prior to entering into a contract. Any award pursuant to the terms and provisions hereof shall be in the best interest of Union County.**

**BID NUMBER: 0098**  
**BID TITLE: HERITAGE PARK STAGE**

**BID SUBMISSION FORM:**

Vendor Name \_\_\_\_\_

Vendor Address \_\_\_\_\_

City \_\_\_\_\_ State \_\_\_\_\_ Zip \_\_\_\_\_

Telephone Number \_\_\_\_\_ Fax Number \_\_\_\_\_

Contact Person \_\_\_\_\_

Contact Person's Email Address \_\_\_\_\_

Total Cost of the Structural Steel Package for the Heritage Park Stage Project:  
\$ \_\_\_\_\_

Project will be completed within \_\_\_\_\_ calendar days of receipt of the formal Notice to Proceed.

- All Vendors must submit a W-9 form with the bid submittal.
- Did you provide your W-9 form? Yes: \_\_\_\_\_ No: \_\_\_\_\_
- Iran Divestment Act:
- By submission of this bid, each bidder and each person signing on behalf of any bidder certifies, and in the case of a joint bid each party thereto certifies as to its own organization, under penalty of perjury, that to the best of its knowledge and belief that each bidder is not on the list created pursuant to Tennessee Code Annotated § 12-12-106.

Authorizing Signature \_\_\_\_\_

(Sign in ink)



**BID NUMBER: 0098**  
**BID TITLE: HERITAGE PARK STAGE**

**SECTION 4. INSURANCE REQUIREMENT CHECKLIST**

The bidder awarded this bid or contract will maintain, at their expense adequate insurance coverage to protect them from claims arising under the Worker's Compensation Act, any and all claims for bodily injury and property damage to the Bidder and to Union County Government while delivery and service are being done. A certificate of insurance *must* be on file in the Purchasing Department before work may begin and must be maintained until work is completed.

**Only the items marked with an "X" are applicable to this bid and or contract.**

- |    |  |   |
|----|--|---|
| 1. | <b>Workers Compensation<br/>Employers Liability</b>  | Statutory limits<br>100,000/100,000/500,000         |
| 2. | <input checked="" type="checkbox"/> <b>Commercial General Liability</b>  | \$1,000,000 per occurrence<br>\$2,000,000 aggregate |
|    | <input checked="" type="checkbox"/> Occurrence Form Only   |   |
|    | <input checked="" type="checkbox"/> Include Premises Liability   |   |
|    | <input checked="" type="checkbox"/> Include Contractual  |   |
|    | <input checked="" type="checkbox"/> Include XCU  |   |
|    | <input checked="" type="checkbox"/> Include Products and Completed Operations  |   |
|    | <input checked="" type="checkbox"/> Include Personal Injury  |   |
|    | <input checked="" type="checkbox"/> Include Independent Contractors  |   |
|    | Include Vendors Liability  |   |
|    | Include Professional or E&O Liability  |   |
| 3. | <b>Business Auto</b>   | \$1,000,000   |
|    | Include Garage Liability   | \$1,000,000   |
|    | Include Garage Keepers Liability   |   |
|    | Copy of Valid Driver's License   |   |
|    | Copy of Current Motor Vehicle Record   |   |
|    | Copy of Current Auto Liability Declarations Page   |   |
| 4. | <b>Crime Coverages</b>   |   |
|    | Employee Dishonesty  |   |
|    | Employee Dishonesty Bond   |   |
| 5. | <b>Property Coverages</b>  |   |
|    | Builders Risk  |   |
|    | Inland Marine  |   |
|    | Transportation   |   |
| 6. | <input checked="" type="checkbox"/> <b>Performance Bond Required</b> — A <u>One Hundred Percent (100%)</u> performance or an irrevocable letter of credit in favor of Union County Government at a federally insured financial institution. <b>MUST</b> be submitted <b>before</b> a purchase order is issued. |   |

**Certificate Holder Shall Be:** Union County Government, Maynardville, Tennessee, and shall show the bid number and title. Union County Government shall be named as an additional insured on all policies except worker's compensation and auto. Insurance carrier ratings shall have a Best's rating of A-VII or better, or its equivalent. Cancellation clause on certificate should strike out "endeavor to" and include a 30-day notice of cancellation where applicable. Any deviations from the above requirements *must* be disclosed to the Union County Purchasing Agent. Any liability deductibles or exclusions must also be disclosed. Exceptions can be granted if applicable.

**Bidders Statement and Certification**

I understand the insurance requirements of these specifications and will comply in full within **21 (twenty-one) calendar days** if awarded this bid and or contract. I agree to furnish the county with proof of insurance for the entire term of the bid and or contract.

Vendor Name	Authorized Signature
Bid Representative Name (Please Print)	Date

**BID NUMBER: 0098**  
**BID TITLE: HERITAGE PARK STAGE**

**DRUG-FREE WORKPLACE AFFIDAVIT**

STATE OF \_\_\_\_\_

COUNTY OF \_\_\_\_\_

The undersigned, principal officer of \_\_\_\_\_, an employer of five (5) or more employees contracting with \_\_\_\_\_ County Government to provide construction services, hereby states under oath as follows:

1. The undersigned is a principal officer of \_\_\_\_\_ (hereinafter referred to as the "Company"), and is duly authorized to execute this Affidavit on behalf of the Company.
2. The Company submits this Affidavit pursuant to T.C.A. 50-9-113, which requires each employer with no less than five (5) employees receiving pay who contracts with the state or any local government to provide construction services to submit an affidavit stating that such employer has a drug-free workplace program that complies with Title 50, Chapter 9 of the *Tennessee Code Annotated*.
3. The Company is compliance with T.C.A. 50-9-113

Further affiant saith not.

\_\_\_\_\_  
Principal Officer

STATE OF \_\_\_\_\_

COUNTY OF \_\_\_\_\_

Before me personally appeared, \_\_\_\_\_ with whom I am personally acquainted (or proved to me on the basis of satisfactory evidence), and who acknowledged that such person executed the foregoing affidavit for the purpose therein contained.

Witness my hand and seal office this \_\_\_\_\_ day of \_\_\_\_\_, 20\_\_

**BID NUMBER: 0098**  
**BID TITLE: HERITAGE PARK STAGE**

**NON –COLLUSION, INDEPENDENT PRICE DETERMINATION, NON-DISCRIMINATION,  
NON-DEBARMENT & LOBBYING AFFIDAVIT**

I do hereby certify that this bid is made without prior understanding, agreement, or connection with any corporation, firm, or person submitting a bid for the same materials, supplies, or equipment, and is in all respects fair and without collusion or fraud.

I understand that collusive pricing is a violation of State and Federal law and can result in fines, prison sentences, and civil damage awards and that no collusion with another firm was used in preparation of this bid.

I also certify that this firm does not discriminate against any employee or applicant for employment on the grounds of race, color, national origin or sex; and does not and will not maintain or provide for his employees any segregated facilities at any of its establishments, and further, that the firm does not and will not permit their employees to perform their services at any location under this contract where segregated facilities are maintained.

By submission of this bid, the bidder certifies that neither it or its principals is presently debarred, suspended, proposed for debarment, declared ineligible or voluntarily excluded from participation in this transaction by any Federal or State department or agency.

I further certify that during the Invitation to Bid solicitation and/or during the performance of this contract that neither it nor its principals will participate in lobbying activities in conjunction with this project.

I agree to abide by all terms and conditions of this Invitation to Bid and certify that I am authorized to sign this affidavit for the vendor.

Please indicate which of the following apply to your company. This information is requested for information purposes only. Union County currently has no policy that allows for set asides or preferences for women owned or minority owned businesses.

- |   |   |
|---|---|
| <input type="checkbox"/> African American Owned | <input type="checkbox"/> Asian Owned    |
| <input type="checkbox"/> Caucasian Owned        | <input type="checkbox"/> Hispanic Owned |
| <input type="checkbox"/> Native American Owned  | <input type="checkbox"/> Woman Owned    |
| <input type="checkbox"/> Other Owned            |   |

\_\_\_\_\_  
Signature

\_\_\_\_\_  
Title







**MMA**  
**ENGINEERING**  
**COMPANY**  
 1227 WHITE HERON KNOXVILLE TN 37916  
 TEL: (605) 607-2224 / FAX: (605) 521-9165  
 EMAIL: ADDRESS MAIL@ENGINEERING.COM

HERITAGE PARK STAGE FOR:  
 UNION COUNTY  
 HIGHWAY 30  
 MAYNARDVILLE, TENNESSEE 37807

Design by: **Maurice Malla**  
 Drawn by: **Garrin Davis**  
 Checked by: **Maurice Malla**  
 Issued date: **01/06/2021**  
 Revision: \_\_\_\_\_ Date: \_\_\_\_\_

Project Number: **202008**  
 Project Name: **HERITAGE PARK STAGE**

FOUNDATION  
 PLAN

**S1.1**

Notes and Abbreviations  
 SEE DRAWING S0.1

**Discretion:**  
 GENERAL CONTRACTOR IS RESPONSIBLE FOR VERIFYING ALL DIMENSIONS AND CONDITIONS MATCH THE STRUCTURAL DRAWINGS. THE CONTRACTOR SHALL BE RESPONSIBLE FOR VERIFYING ALL DIMENSIONS AND CONDITIONS MATCH THE STRUCTURAL DRAWINGS. THE CONTRACTOR SHALL BE RESPONSIBLE FOR VERIFYING ALL DIMENSIONS AND CONDITIONS MATCH THE STRUCTURAL DRAWINGS. THE CONTRACTOR SHALL BE RESPONSIBLE FOR VERIFYING ALL DIMENSIONS AND CONDITIONS MATCH THE STRUCTURAL DRAWINGS.

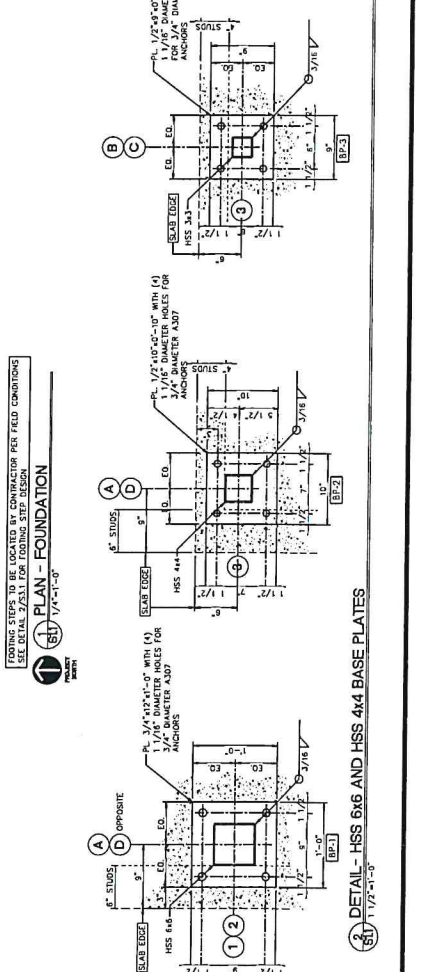
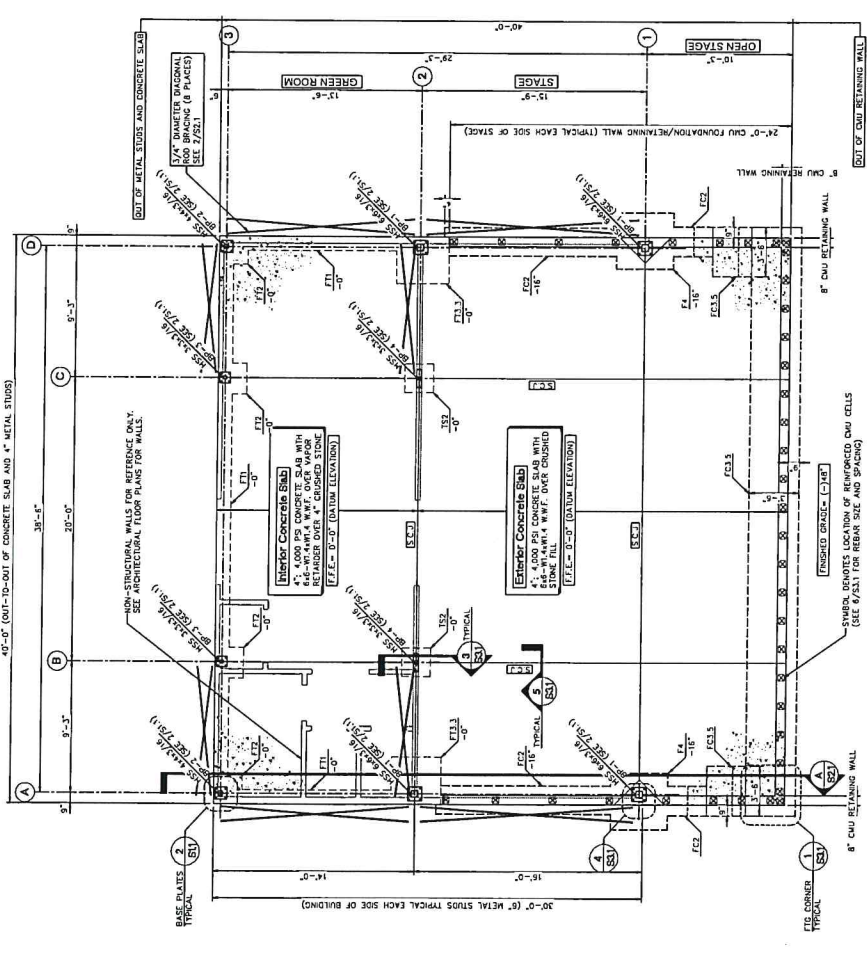
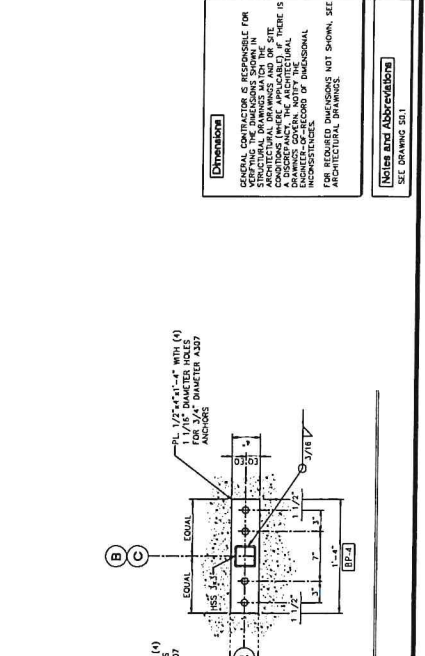
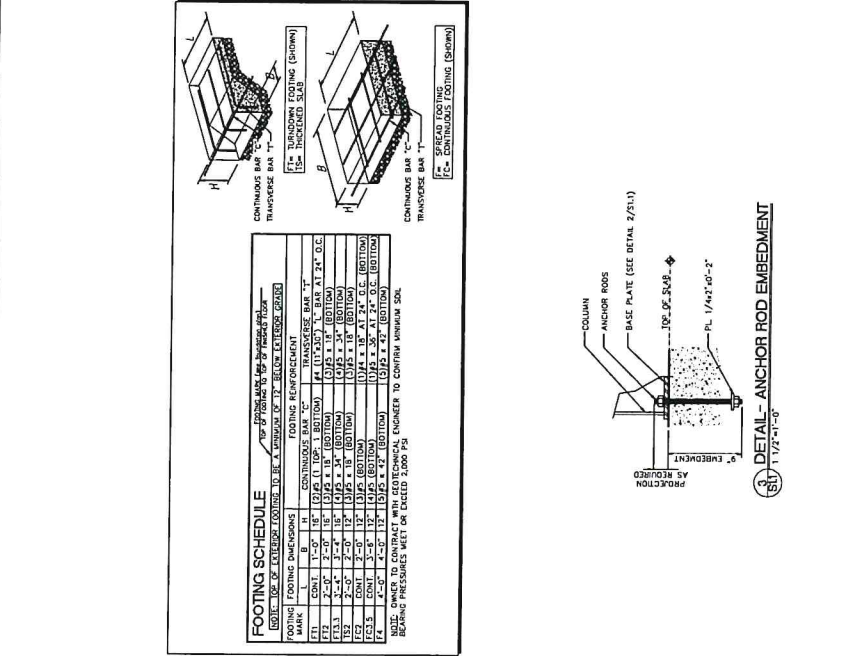



**M M**  
**ENGINEERING**  
**KNOXVILLE, TENNESSEE**  
 1827 WHITE AVENUE, KNOXVILLE, TN 37916  
 TEL: (605) 607-2224 / FAX: (605) 521-9185  
 EMAIL ADDRESS: MALLA@ENGINEERING.COM

HERITAGE PARK STAGE FOR  
 UNION COUNTY  
 HIGHWAY 30  
 MAYNARDVILLE, TENNESSEE 37807

Design by: **Maurice Malla**  
 Drawn by: **Garnie Davis**  
 Checked by: **Maurice Malla**  
 Issued date: **07/06/2021**  
 Revision: \_\_\_\_\_  
 Date: \_\_\_\_\_

Project Number: **20008**  
 Package Title: **20008**  
 Issued Date: **07/06/2021**

ROOF  
 FRAMING PLAN

**S1.2**

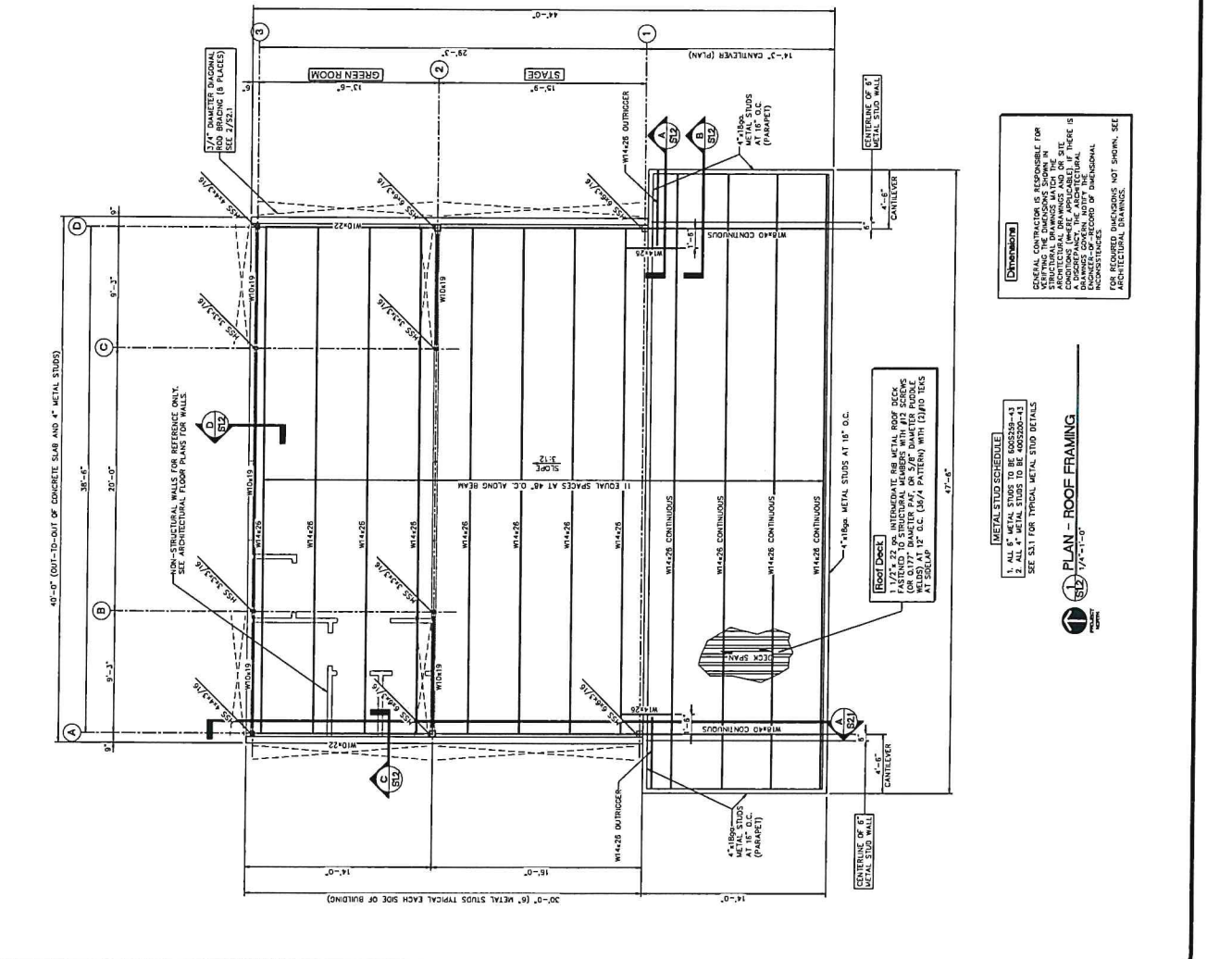
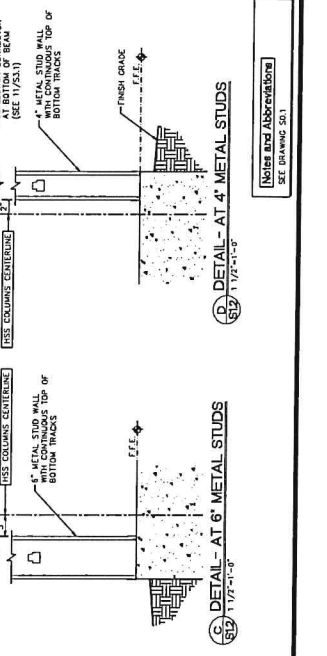
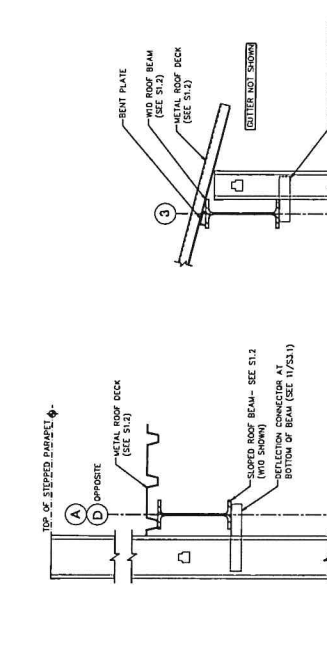
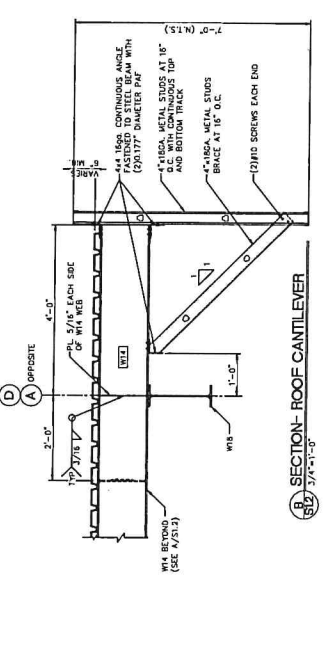
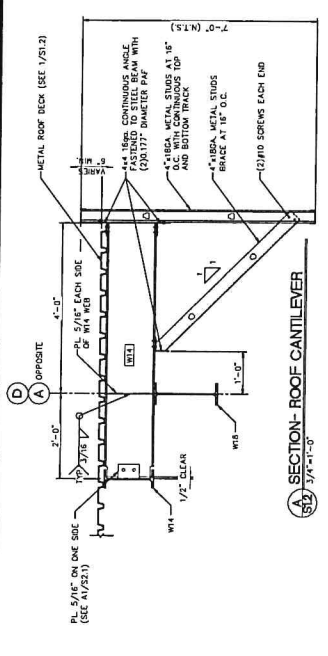

**NOTES AND ABBREVIATIONS**  
 SEE DRAWING S01

**METAL STUD SCHEDULE**  
 1. ALL 4" METAL STUDS TO BE 605555-43  
 2. ALL 6" METAL STUDS TO BE 605555-43  
 SEE S01 FOR TYPICAL METAL STUD DETAILS

**Roof Deck**  
 1 1/2" x 2" OR INTERMEDIATE RIB METAL ROOF DECK  
 (OR 0.177" DIAMETER PAF OR 5/8" DIAMETER PUDLE  
 AT 250/40" O.C. (M/A PATTERN) WITH (D/10) TEES

**Disclaimer**  
 DESIGNER ASSUMES NO RESPONSIBILITY FOR  
 VERIFYING THE DIMENSIONS SHOWN IN  
 ARCHITECTURAL DRAWINGS AND THE SITE  
 CONDITIONS. THE DESIGNER SHALL BE  
 RESPONSIBLE FOR VERIFYING THE DIMENSIONS  
 AND CONDITIONS OF THE SITE.  
 DIMENSIONS SHOWN ON THIS DRAWING  
 TAKE PRECEDENCE OVER ANY OTHER  
 DIMENSIONS OR CONDITIONS NOT SHOWN. SEE  
 ARCHITECTURAL DRAWINGS.







**M MALLA**  
ENGINEERING  
COMPANY  
1827 WHITE AVENUE, KNOXVILLE, TN 37916  
TEL: (605) 637-2224 / FAX: (605) 524-9165  
EMAIL: ADDRESS@MALLAENGINEERING.COM

**BUILDING EXPANSION FOR  
UNION COUNTY FARMERS MARKET  
1009 MAIN STREET  
MAYNARDVILLE, TENNESSEE 37807**

Design by  
**Maurice Malla**  
Drawn by  
**Garriss Davis**  
Checked by  
**Maurice Malla**  
Issued date:  
**07/16/2021**

Revision	Date

PROJECT NUMBER: 20007  
SHEET NO.: 20007P  
SHEET DATE: 07/16/2021

DETAILS AND SECTIONS

**S3.1**

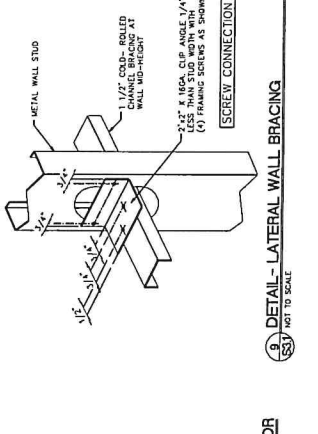
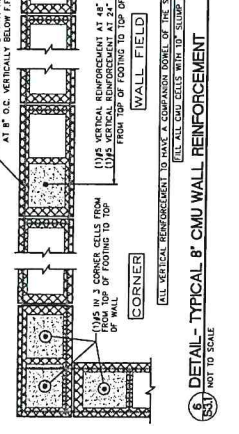
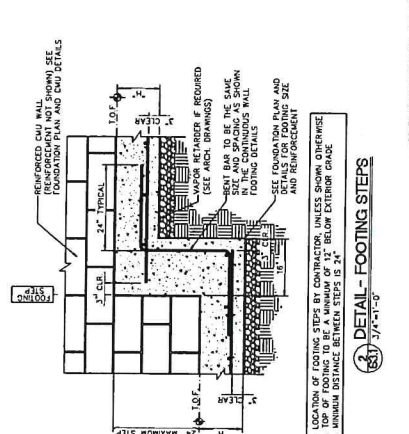
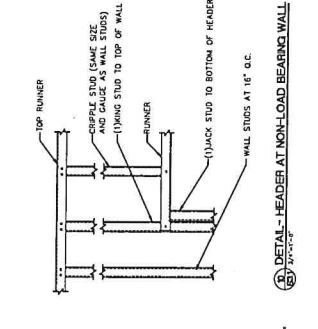
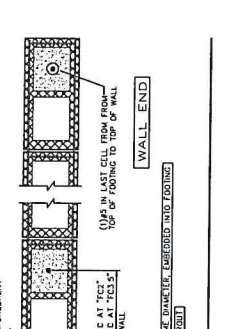
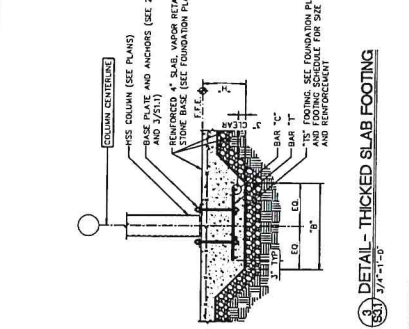
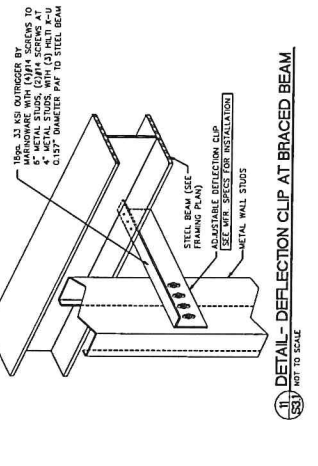
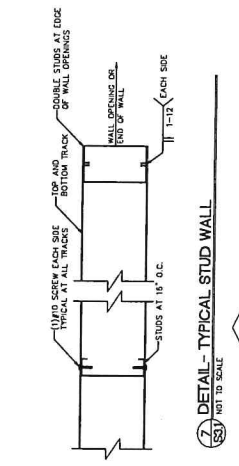
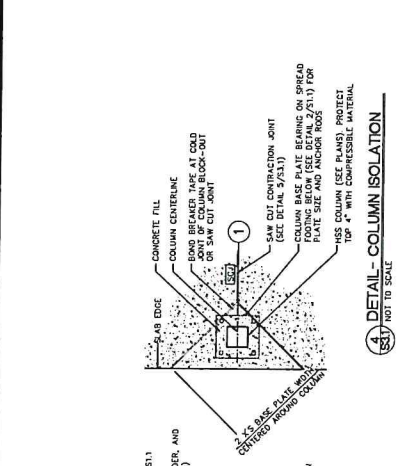

Metal Stud Fastener Schedule	
COMPONENTS	FASTENERS
(1) TOP AND BOTTOM TRACKS	(1) #10-18 SELF-TAPPING SCREWS PER STUD
(2) #10-18 SELF-TAPPING SCREWS PER STUD	(2) #10-18 SELF-TAPPING SCREWS PER STUD
(3) 2X4S SHANK DIAMETER POWER ACTUATED FASTENER AT 12\"/>	
(4) #10-18 SELF-TAPPING SCREWS PER STUD	(4) #10-18 SELF-TAPPING SCREWS PER STUD
(5) #10-18 SELF-TAPPING SCREWS PER STUD	(5) #10-18 SELF-TAPPING SCREWS PER STUD